

Service Manual

CHASSIS : CP-850FX

MODEL : DTF-2950-100D

DTF-2950GB-100D

DTF-2950K-100D

DTF-2930-100D

DTF-2930GB-100D

DTF-2930K-100D

DAEWOO

Caution

: In this Manual, some parts can be changed for improving. their performance without notice in the parts list. So, if you need the latest parts information, please refer to PPL(Parts Price List)in Service Information Center.

CONTENTS

DOCUMENT HISTORY	5
1 MAIN FEATURES.....	6
1.1 SPECIFICATIONS	6
1.1.1 GENERAL.....	6
1.1.2 EURO-SCART 1 (21 Pin)	6
1.1.3 EURO-SCART 2 (21 Pin)	7
1.2 CHANNEL/FREQUENCY TABLE	8
1.3 ATSS SORTING METHOD.....	11
1.3.1 GENERAL CASE.....	11
1.3.2 SPECIAL CASE.....	11
2 SAFETY INSTRUCTION	13
3 ALIGNMENT INSTRUCTIONS.....	14
3.1 MICROCONTROLLER CONFIGURATION : SERVICE MODE	14
3.2 SERVICE MODE NAVIGATION.....	14
3.3 MICROCONTROLLER CONFIGURATION : OPTION BITS	14
3.3.1 OPTION 1.....	15
3.3.2 OPTION 2.....	15
3.3.3 OPTION 3.....	15
3.4 TV SET ALIGNMENT.....	16
3.4.1 LOCAL OSCILLATOR ALIGNMENT	16
3.4.2 G2 ALIGNMENT.....	16
3.4.3 WHITE BALANCE	16
3.4.4 FOCUS.....	16
3.4.5 VERTICAL GEOMETRY	16
3.4.6 HORIZONTAL PICTURE CENTRING	16
3.4.7 EAST / WEST CORRECTION.....	16
3.4.8 AGC	17
4 IC DESCRIPTION.....	18
4.1 TELETEXT DECODER WITH EMBEDDED 8-BIT CONTROLLER.....	18
4.1.1 BLOCK DIAGRAM OF THE SDA55XX.....	18
4.1.2 DESCRIPTION	18
4.1.3 IC MARKING AND VERSION.....	19
4.1.4 PINNING.....	19
4.2 VSP94X5B (VERSION C4)– OPTIMUS COLOR DECODER AND SCAN-RATE CONVERTER.....	21
4.2.1 BLOCK DIAGRAM OF THE VSP94x5B	21
4.2.2 Feature Overview	22
4.2.3 PINNING.....	23
4.3 DDP 3315C – DISPLAY AND DEFLECTION PROCESSOR.....	25
4.3.1 BLOCK DIAGRAM OF THE DDP 3315C.....	25
4.3.2 DESCRIPTION	25
4.3.3 PINNING.....	27
4.4 MSP341X MULTISTANDARD SOUND PROCESSOR.....	29
4.4.1 BASIC FEATURES OF THE MSP 341X.....	29
4.4.1.1 Demodulator & NICAM Decoder Section.....	29
4.4.1.2 DSP-Section (Audio Baseband Processing)	30
4.4.1.3 Analogue Section.....	30
4.4.1.4 NICAM & FM/AM-Mono	30

4.4.1.5 German 2-Carrier System (DUAL FM System)	30
4.5 TDA4470 - MULTISTANDARD VIDEO-IF AND QUASI PARALLEL SOUND PROCESSOR	33
4.5.1 DESCRIPTION	33
4.5.2 FEATURES.....	33
4.5.3 PINNING.....	33
4.5.4 BLOCK DIAGRAM.....	34
4.6 TDA8946J STEREO AUDIO AMPLIFIER	35
4.6.1 FEATURES.....	35
4.7 TDA8358J VERTICAL AMPLIFIER.....	37
4.7.1 FEATURES.....	37
4.8 TDA6108JF	39
4.9 24C16 - 16 KB EEPROM	40
4.10STR – W6754.....	41
4.10.1 GENERAL DESCRIPTION	41
4.10.2 FEATURES.....	41
4.10.3 BLOCK DIAGRAM.....	41
4.10.4 PIN DESCRIPTION	42
4.10.5 MOSFET ELECTRICAL CHARACTERISTICS.....	42
4.10.6 ELECTRICAL CHARACTERISTICS.....	43
5 CP-850FX CHASSIS DESCRIPTION.....	44
5.1 POWER SUPPLY BLOCK DIAGRAM.....	44
5.2 VIDEO & STEREO AUDIO BLOCK DIAGRAM.....	45
5.3 IF SECTION	46
5.3.1 BLOCK DIAGRAM.....	46
5.3.2 VISION IF AMPLIFIER	47
5.3.3 TUNER-AND VIF-AGC	47
5.3.4 FPLL, VCO AND AFC.....	47
5.3.5 VIDEO DEMODULATION AND AMPLIFIER	48
5.3.6 SOUND IF AMPLIFIER AND SIF-AGC.....	48
5.3.7 QUASI-PARALLEL-SOUND (QPS) MIXER.....	48
5.3.8 STANDARD SWITCH.....	48
5.3.9 L' SWITCH.....	48
5.3.10 INTERNAL VOLTAGE STABILISER	48
5.4 VIDEO / RGB	48
5.4.1 FRONT END.....	48
5.4.1.1 CVBS Front-End	48
5.4.1.2 Input Selector.....	49
5.4.1.3 Signal Levels And Gain Control	49
5.4.1.4 Synchronization	49
5.4.1.5 Chroma Decoder	49
5.4.1.6 Luminance Processing.....	49
5.4.1.7 RGB Front-End	49
5.4.1.8 Signal Processing	49
5.4.1.8.1 Horizontal Prescaler.....	49
5.4.1.8.2 Noise Reduction	50
5.4.1.8.3 Noise Measurement.....	50
5.4.1.8.4 Operation Modes	50
5.4.1.8.5 Digital 656 Output	50
5.4.2 BACK END	50
5.4.2.1 Digital Input Interface	50
5.4.2.2 Horizontal Scaler	50
5.4.2.3 Luma Contrast and Brightness	51

5.4.2.4 Black Level Expander/Compressor (BLEC)	51
5.4.2.5 Luma Sharpness Enhancer (LSE)	51
5.4.2.6 Dynamic Peaking	51
5.4.2.7 Luma Transient Improvement (LTI)	51
5.4.2.8 Mixing of Dynamic Peaking and LTI	51
5.4.2.9 Chroma Transient Improvement	51
5.4.2.10 Analog Back End	53
5.4.2.11 Analog RGB Insertion	53
5.4.2.12 CRT Measurement and Control	53
5.4.2.13 Synchronization and Deflection	54
5.4.2.14 EHT Compensation	54
5.5 MICRONTROLLER	54
5.5.1 MICROCONTROLLER FEATURES	54
5.5.2 ACQUISITION FEATURES	54
5.5.3 PORTS	55
5.5.4 μ -CONTROLLER I/O PIN CONFIGURATION AND FUNCTION TABLE	55
5.5.5 TUNING	55
5.5.6 AUTOMATIC PICTURE FORMAT SWITCHING	56
5.5.6.1 WSS Data	56
5.5.6.2 SCART Pin 8 Data (Slow Switching)	57
5.5.6.3 Picture Format Description	57
5.3.1.8.1 16:9 CRT	57
5.3.1.8.2 4:3 CRT	58
5.5.7 EXTERNAL SOURCE CONTROL LOGIC	59
5.5.8 OVER CURRENT PROTECTION	60
5.6 TELETEXT DISPLAY	60
5.7 SOUND PROCESSING	61
5.7.1 ANALOGUE SOUND IF - INPUT SECTION	61
5.7.2 QUADRATURE MIXERS	61
5.7.3 PHASE AND AM DISCRIMINATION	61
5.7.4 NICAM DECODER	62
5.7.5 DSP SECTION	62
5.7.6 SOUND MODE SWITCHING	62
5.8 SOUND AMPLIFICATION	62
5.8.1 POWER AMPLIFIER	62
5.8.2 MODE SELECTION	63
5.9 VERTICAL DEFLECTION	63
5.9.1 FLYBACK VOLTAGE	63
5.9.2 PROTECTION	63
5.9.3 GUARD CIRCUIT	63
5.9.4 DAMPING RESISTOR	63
5.9.5 EAST-WEST AMPLIFIER	63
5.10 POWER SUPPLY (STR-W6754) - FUNCTIONS OF EACH TERMINAL	64
5.10.1 Vcc Terminal (Pin 4)	64
5.10.1.1 Start-up Circuit	64
5.10.1.2 Auxiliary/Drive Winding	65
5.10.1.3 Overvoltage Protection Circuit	66
5.10.1.4 Latch Circuit	67
5.10.2 SS/OLP Terminal (Pin 5)	67
5.10.2.1 Soft-Start Operation at Start-up of Power Supply	67
5.10.2.2 Overload Protection	68
5.10.2.3 Operation at Power Supply OFF	69

5.10.2.4 Cancellation of OLP ircuit.....	69
5.10.3 FB Terminal (Pin. 6).....	70
5.10.3.1 Constant Voltage Control Circuit.....	70
5.10.4 OCP/BD Terminal (Pin 7).....	71
8.4.1. Minus-Detection Type OCP Circuit.....	71
5.10.5 Quasi-Resonant and Bottom-Skip Operation.....	72
5.10. 5. 1 Quasi-Resonant Operation.....	72
5.10.5.2 Bottom-Skip Operation (Switching from Quasi-Resonant Operation).....	73
1). Quasi-Resonant Operation --> Bottom-Skip Operation.....	73
2). Bottom-Skip Operation --> Quasi-Resonant Operation	73
5.10.6 Stand-By Operation.....	74
5.10.7 Step-Drive Circuit.....	76
5.10.8 Maximum ON Time Controlling Function	76
6 SERVICE PARTS LIST	78
6.1 DTF-2950.....	78
6.2 DTF-2930.....	86
7 EXPLODED VIEW	94
7.1 DTF-2950.....	94
7.2 DTF-2930.....	95
8 PRINTED CIRCUIT BOARD	96
8.1 MAIN PCB.....	96
8.2 NIONPCB.....	97
8.3 CRT PCB	98
9 SCHEMATIC DIAGRAM	99
9.1 MAIN.....	99
9.2 UNION & CRT.....	100

DOCUMENT HISTORY

VERSION	DATE	COMMENTS
V1.00	31/07/06	Creation of document (Author JS KIM) for project CP-850FX 100Hz TV.

1 MAIN FEATURES

1.1 SPECIFICATIONS

1.1.1 GENERAL

TV standard		PAL/SECAM-B/G, D/K, PAL-I/I, SECAM-L/L'
Colour system	Tuner	PAL, SECAM
	AV	PAL, SECAM, PAL 60, NTSC M, NTSC 4.43
Sound system		NICAM B/G, I, D/K, L, FM 2Carrier B/G, D/K
Power consumption		105W
Sound Output Power		7W x 2 (at 60% mod, 10%THD)
Speaker		12W 8 ohm x2
Teletext system		9 pages memory FASTEXT (FLOF or TOP)
Aerial input		75 ohm unbalanced
Channel coverage		Off-air channels, S-cable channels and hyperband
Tuning system		frequency synthesiser tuning system
Visual screen size		68cm
Channel indication		On Screen Display
Program Selection		100 programmes
Aux. terminal		EURO-SCART 1 : Audio / Video In and Out, R/G/B In, Slow and Fast switching. EURO-SCART 2 : Audio / Video In and Out, SVHS In. AV3 : Audio-Video Jack on side of cabinet. Headphone jack (3.5 mm) on side of cabinet SVHS3 : Jack on side of cabinet – sound input common with AV3.
Remote Control Unit		R-49C10(AAA)

1.1.2 EURO-SCART 1 (21 Pin)

Pin	Signal Description	Matching value
1	Audio Output Right	0.5 Vrms, Impedance < 1 k Ω , (RF 54% Mod)
2	Audio Input Right	0.5 Vrms, Impedance > 10 k Ω
3	Audio Output Left	0.5 Vrms, Impedance < 1 k Ω , (RF 54% Mod)
4	Audio Earth	
5	Blue Earth	
6	Audio Input Left	0.5 Vrms, Impedance > 10 k Ω
7	Blue Input	0.7 Vpp \pm 0.1V, Impedance 75 Ω
8	Slow Switching	TV : 0 to 2V, AV 16/9 : 4.5 to 7V, AV 4/3 : 9.5 to 12V , Impedance > 10 k Ω
9	Green Earth	

10	N.C.	
11	Green Input	0.7 Vpp \pm 0.1V, Impedance 75 Ω
12	N.C.	
13	Red Earth	
14	Blanking Earth	
15	Red Input	0.7 Vpp \pm 0.1V, Impedance 75 Ω
16	Fast Switching	0 to 0.4V : Logic "0", 1 to 3V : Logic "1", Impedance 75 Ω
17	Video Out Earth	
18	Video In Earth	
19	Video Output	1 Vpp \pm 3dB, Impedance 75 Ω
20	Video Input	1 Vpp \pm 3dB, Impedance 75 Ω
21	Common Earth	

1.1.3 EURO-SCART 2 (21 Pin)

Pin	Signal Description	Matching value
1	Audio Output Right	0.5 Vrms, Impedance < 1 k Ω , (RF 54% Mod)
2	Audio Input Right	0.5 Vrms, Impedance > 10 k Ω
3	Audio Output Left	0.5 Vrms, Impedance < 1 k Ω , (RF 54% Mod)
4	Audio Earth	
5	Earth	
6	Audio Input Left	0.5 Vrms, Impedance > 10 k Ω
7	N.C.	
8	Slow Switching	TV : 0 to 2V, AV 16/9 : 4.5 to 7V, AV 4/3 : 9.5 to 12V , Impedance > 10 k Ω
9	Earth	
10	N.C.	
11	N.C.	
12	N.C.	
13	Earth	
14	Earth	
15	Chroma Input	\pm 3dB for a luminance signal of 1 Vpp
16	N.C.	
17	Earth	
18	Video In Earth	
19	Video Output	1 Vpp \pm 3dB, Impedance 75 Ω (Monitor output)
20	Video Input, Y In.	1 Vpp \pm 3dB, Impedance 75 Ω
21	Common Earth	

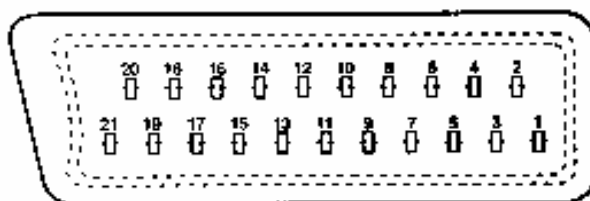

1.2 CHANNEL/FREQUENCY TABLE

CHANNEL	EUROPE CCIR	FRANCE	GB(IRELAND)	EAST OIRT
C01	46.25	-	45.75	49.75
C02	48.25	55.75 (L')	53.75	59.25
C03	55.25	60.5 (L')	61.75	77.25
C04	62.25	63.75 (L')	175.25	85.25
C05	175.25	176.00	183.25	93.25
C06	182.25	184.00	191.25	175.25
C07	189.25	192.00	199.25	183.25
C08	196.25	200.00	207.25	191.25
C09	203.25	208.00	215.25	199.25
C10	210.25	216.00	223.25	207.25
C11	217.25	189.25 (LUX)	231.25	215.25
C12	224.25	69.25 (L')	239.25	223.25
C13	53.75	76.25 (L')	247.25	-
C14	-	83.25 (L')	49.75	-
C15	82.25	90.25	57.75	-
C16	-	97.25	65.75	-
C17	183.75	-	77.75	-
C18	192.25	-	85.75	-
C19	201.25	-	-	-
C20	-	-	-	-
C21	471.25	471.25	471.25	471.25
C22	479.25	479.25	479.25	479.25
C23	487.25	487.25	487.25	487.25
C24	495.25	495.25	495.25	495.25
C25	503.25	503.25	503.25	503.25
C26	511.25	511.25	511.25	511.25
C27	519.25	519.25	519.25	519.25
C28	527.25	527.25	527.25	527.25
C29	535.25	535.25	535.25	535.25
C30	543.25	543.25	543.25	543.25
C31	551.25	551.25	551.25	551.25
C32	559.25	559.25	559.25	559.25
C33	567.25	567.25	567.25	567.25
C34	575.25	575.25	575.25	575.25
C35	583.25	583.25	583.25	583.25
C36	591.25	591.25	591.25	591.25
C37	599.25	599.25	599.25	599.25
C38	607.25	607.25	607.25	607.25
C39	615.25	615.25	615.25	615.25
C40	623.25	623.25	623.25	623.25
C41	631.25	631.25	631.25	631.25
C42	639.25	639.25	639.25	639.25
C43	647.25	647.25	647.25	647.25
C44	655.25	655.25	655.25	655.25
C45	663.25	663.25	663.25	663.25
C46	671.25	671.25	671.25	671.25

C47	679.25	679.25	679.25	679.25
C48	687.25	687.25	687.25	687.25
C49	695.25	695.25	695.25	695.25
C50	703.25	703.25	703.25	703.25
C51	711.25	711.25	711.25	711.25
C52	719.25	719.25	719.25	719.25
C53	727.25	727.25	727.25	727.25
C54	735.25	735.25	735.25	735.25
C55	743.25	743.25	743.25	743.25
C56	751.25	751.25	751.25	751.25
C57	759.25	759.25	759.25	759.25
C58	767.25	767.25	767.25	767.25
C59	775.25	775.25	775.25	775.25
C60	783.25	783.25	783.25	783.25
C61	791.25	791.25	791.25	791.25
C62	799.25	799.25	799.25	799.25
C63	807.25	807.25	807.25	807.25
C64	815.25	815.25	815.25	815.25
C65	823.25	823.25	823.25	823.25
C66	831.25	831.25	831.25	831.25
C67	839.25	839.25	839.25	839.25
C68	847.25	847.25	847.25	847.25
C69	855.25	855.25	855.25	855.25
C70	863.25	863.25	863.25	863.25
C71	69.25	-	-	-
C72	76.25	-	-	-
C73	83.25	-	-	-
C74	90.25	-	-	-
C75	97.25	-	-	-
C76	59.25	-	-	-
C77	93.25	-	-	-
S01	105.25	104.75	103.25	105.25
S02	112.25	116.75	111.25	112.25
S03	119.25	128.75	119.25	119.25
S04	126.25	140.75	127.25	126.25
S05	133.25	152.75	135.25	133.25
S06	140.25	164.75	143.25	140.25
S07	147.25	176.75	151.25	147.25
S08	154.25	188.75	159.25	154.25
S09	161.25	200.75	167.25	161.25
S10	168.25	212.75	-	168.25
S11	231.25	224.75	-	231.25
S12	238.25	236.75	-	238.25
S13	245.25	248.75	255.25	245.25
S14	252.25	260.75	263.25	252.25
S15	259.25	272.75	271.25	259.25
S16	266.25	284.75	279.25	266.25
S17	273.25	296.75	287.25	273.25
S18	280.25	136.00	295.25	280.25

S19	287.25	160.00	303.25	287.25
S20	294.25	-	-	294.25
S21	303.25	303.25	-	303.25
S22	311.25	311.25	311.25	311.25
S23	319.25	319.25	319.25	319.25
S24	327.25	327.25	327.25	327.25
S25	335.25	335.25	335.25	335.25
S26	343.25	343.25	343.25	343.25
S27	351.25	351.25	351.25	351.25
S28	359.25	359.25	359.25	359.25
S29	367.25	367.25	367.25	367.25
S30	375.25	375.25	375.25	375.25
S31	383.25	383.25	383.25	383.25
S32	391.25	391.25	391.25	391.25
S33	399.25	399.25	399.25	399.25
S34	407.25	407.25	407.25	407.25
S35	415.25	415.25	415.25	415.25
S36	423.25	423.25	423.25	423.25
S37	431.25	431.25	431.25	431.25
S38	439.25	439.25	439.25	439.25
S39	447.25	447.25	447.25	447.25
S40	455.25	455.25	455.25	455.25
S41	463.25	463.25	463.25	463.25

1.3 ATSS SORTING METHOD

The TV set sweeps all the TV bands from beginning of VHF to end of UHF. The TV controlling software for each program checks if a VPS CNI code is transmitted (this system exists for German, Swiss and Austrian transmissions).

If no VPS CNI code is found, then the system checks if a CNI code is transmitted as part of the teletext transmission (Packet 8/30 format 1 and format 2). If such a code (VPS or teletext) is found and if this code is in the ATSS list, the program is automatically named.

If the transmission does not have VPS CNI, and no teletext service is available, then there is no possibility of the program being automatically named.

The programs found are then sorted in 4 groups :

Group I : It contains all the programs from the selected country and named by the TV controlling software. Within this group the sorting order is fixed by the ATSS list.

Group II : It contains all the programs with a strong signal strength which are not listed in group I.

Group III : It contains all the programs with a weak signal strength which are not listed in group I.

Group IV : If two or more programs with the same code are found, only the strongest (or if they have the same level the one with the lowest frequency) is listed in group I, II or III. The others are listed in group IV.

1.3.1 GENERAL CASE

Program number	Group	Skip
1	Group I	
2		
...		
n	Group II	
n+1		
...		
m	Group III	
m+1		
...		
p	Group IV	
p+1		✓
...		
q	not used	
q+1		✓
...		
99		
0		

1.3.2 SPECIAL CASE

Program number	Group	Skip
1	Group II	
...		
m		
m+1	Group III	
...		
p		
p+1	Group IV	✓
...		
q		
q+1	not used	✓
...		
99		
0		

Special case : Country selection = Others

Note : If two programs with the same name but a different code are found these two programs are listed in group I, II or III .

The sorting order within group II, III, and IV is based on the channel frequency. The program with the lowest frequency is allocated the first rank in its group, and so forth until the last program of the group which has the highest frequency.

Special case : France

If France is selected, the TV controlling software first sweeps all TV bands with France system selected (positive video modulation) and then a second time with Europe system selected (negative video modulation).

Special case : Switzerland

If Switzerland is selected the TV controlling software first sweeps all TV bands with Europe system selected (negative video modulation) and then a second time with France system selected (positive video modulation).

Special case : GB

Note for satellite receiver users : Before starting ATSS turn on your satellite receiver and tune to " SKY NEWS ".

If GB is selected the TV controlling software seeks for programs only in UHF (C21 to C70). The sorting order is :

- 1 - BBC1
- 2 - BBC2
- 3 - ITV
- 4 - CH4
- 5 - CH5
- 6 – NEWS (Sky News)

If two or more " identical "programs (same name but different code e.g. BBC1 and BBC1 Scotland) are found the following programs in the list will be shifted up. (1 - BBC1, 2 - BBC1, 3 - BBC2, 4 - ITV, 5 - CH4, 6 - CH5, 7 - NEWS, ..)

If one of the programs above is not found, the associated program number remains empty (freq.=467.25 MHz - Skip selected - no name – system = GB).

example A : 1 - BBC1, 2 - BBC2, 3 - ITV, 4 - -----, 5 - CH5, 6 - NEWS, ...

example B (if 2 BBC1 found) : 1 - BBC1, 2 - BBC1, 3 - BBC2, 4 - ITV, 5 - -----, 6 - CH5, 7 - NEWS, ...

2 SAFETY INSTRUCTION

WARNING: Only competent service personnel may carry out work involving the testing or repair of this equipment.

X-RAY RADIATION PRECAUTION

1. Excessive high voltage can produce potentially hazardous X-RAY RADIATION. To avoid such hazards, the high voltage must not exceed the specified limit. The nominal value of the high voltage of this receiver is 25-26 KV (20"-21") or 26 KV (25" - 28") at max beam current. The high voltage must not, under any circumstances, exceed 27.5 KV (20"), 29KV (21"), 29.5 KV (25") or 30 KV (28"). Each time a receiver requires servicing, the high voltage should be checked. It is important to use an accurate and reliable high voltage meter.
2. The only source of X-RAY Radiation in this TV receiver is the picture tube. For continued X-RAY RADIATION protection, the replacement tube must be exactly the same type tube as specified in the parts list.

SAFETY PRECAUTION

Potentials of high voltage are present when this receiver is operating. Operation of the receiver outside the cabinet or with the back board removed involves a shock hazard from the receiver. Servicing should not be attempted by anyone who is not thoroughly familiar with the precautions necessary when working on high voltage equipment.

Discharge the high potential of the picture tube before handling the tube. The picture tube is highly evacuated and if broken, glass fragments will be violently expelled.

If any Fuse in this TV receiver is blown, replace it with the FUSE specified in the Replacement Parts List.

When replacing a high wattage resistor (metal oxide film resistor) in the circuit board, keep the resistor 10 mm away from circuit board.

Keep wires away from high voltage or high temperature components.

This receiver must operate under AC 230 volts, 50 Hz. NEVER connect to a DC supply or any other voltage or frequency.

PRODUCT SAFETY NOTICE

Many electrical and mechanical parts in this equipment have special safety-related characteristics. These characteristics are often passed unnoticed by a visual inspection and the X-RAY RADIATION protection afforded by them cannot necessarily be obtained by using replacement components rated for higher voltage, wattage, etc. Replacement parts which have these special safety characteristics are identified in this manual and its supplements, electrical components having such features are identified by designated symbol on the parts list. Before replacing any of these components, read the parts list in this manual carefully. The use of substitutes replacement parts which do not have the same safety characteristics as specified in the parts list may create X-RAY Radiation.

3 ALIGNMENT INSTRUCTIONS

3.1 MICROCONTROLLER CONFIGURATION : SERVICE MODE

To switch the TV set into service mode please see instruction below.

1 - Select PR. number 91

2 - Adjust sharpness to minimum and exit all menus.

3 – Within 2 seconds press the key sequence : **RED - GREEN - menu**

The software version is displayed beside the word Service, e.g. “SERVICE V1.00”.

To exit SERVICE menu press **menu** key or **Std By** key.

3.2 SERVICE MODE NAVIGATION

Pr Up/Down remote keys : cycle through the service items available.

Vol -/+ remote keys : Dec./Increment the values within range – Cycle trough option bits.

OK key : Toggle bits in option byte

Order	Item	Default setting
		Note:All settings are approximate
1	HOR CEN	-154
2	RED GAIN	412
3	GRN GAIN	363
4	BLUE GAIN	380
5	RED BIAS	226
6	GRN BIAS	210
7	AGC LEVEL	56
8	G2 – SCREEN	32
9	AFT	32
10	AVL	OFF
11	OPTION1	0011 1000 [0x38]
12	OPTION2	0000 0110 [0x06]
13	OPTION3	1111 1111 [0xFF]
14	PARABOLA	346
15	HOR WIDTH	-71
16	CORNER T	-100
17	CORNER B	-30
18	HOR. PARAL	2
19	V. LINEAR	16
20	EW TRAPEZ	12
21	S CORRECT	130
22	VERT CENT	-14
23	VERT SIZE	40
24	SHIPPING	OFF

3.3 MICROCONTROLLER CONFIGURATION : OPTION BITS

There are three option bytes available (16 bits in all). These option bits are available from Service mode. First find the OPTION1 or OPTION2 control, and then use the Volume PLUS/MINUS buttons on the remote control keypad to locate the bits, and OK key to toggle them. The table below shows the two option bytes available;

3.3.1 OPTION 1

	B7	B6	B5	B4	B3	B2	B1	B0
1	TOP Teletext OFF	FASTEXT (FLOF) OFF	TUBE 4:3	Headphone Volume/Balance control OFF	Dolby Virtual OFF	SVHS3 disable	<u>Tuner options</u> 00 = Philips 01 = not used 10 = ALPS 11 = PARTSNIC	
0	TOP Teletext ON	FASTEXT (FLOF) ON	TUBE 16:9	Headphone Volume/Balance control ON	Dolby Virtual ON	SVHS3 enable		

3.3.2 OPTION 2

	B7	B6	B5	B4	B3	B2	B1	B0
1	Fixed to '0'	JVC remote control	AVL control OFF	PICTURE TILT ON	Program list enabled	See table below		
0		Daewoo Remote control	AVL control ON	PICTURE TILT OFF	Program list disabled			

3.3.3 OPTION 3

	B7	B6	B5	B4	B3	B2	B1	B0
1	Must be set to "1" for future compatibility			Local keyboard : 6 keys	Must be set to "1" for future compatibility (See CP830 NEC)	OSD display "AV" in extern mode	AV3 Enabled	Full ATSS
0				Local keyboard : 5 keys		OSD display "EXT" in extern mode (JVC only)	AV3 Disabled (NEC only)	Basic ATSS

Tube	Beam		Current (mA)	B2	B1	B0
	Nominal	Max				
	0.95	1.10		0	0	0
	1.00	1.15		0	0	1
	1.05	1.20		0	1	0
	1.10	1.25		0	1	1
	1.20	1.35		1	0	0
LG PHILIPS CRT	1.25	1.40		1	0	1
SAMSUNG SDI CRT	1.30	1.45		1	1	0
	1.35	1.50		1	1	1

All values modified are immediately memorised in eeprom.

3.4 TV SET ALIGNMENT

3.4.1 LOCAL OSCILLATOR ALIGNMENT

Tune a colour bar pattern. The frequency of the signal carrier must be accurate (Max +/- 10KHz deviation from the nominal channel frequency).

Find "AFT" item in service mode.

Adjust the coil L150 to bring the cursor to central position : 32.

3.4.2 G2 ALIGNMENT

- Tune a colour bar pattern.

- Find the "G2 – SCREEN" item in service mode.

- Adjust screen volume (on FBT) to bring the cursor to central position : 32.

3.4.3 WHITE BALANCE

- Select a dark picture and adjust RED BIAS and GRN BIAS to the desired colour temperature.

- Select a bright picture and adjust RED, GRN and BLUE GAIN to the desired colour temperature.

3.4.4 FOCUS

Adjust the Focus volume (on FBT) to have the best resolution on screen.

3.4.5 VERTICAL GEOMETRY

Adjust V. LINEAR (linearity), S CORRECT (S. Correction), VERT SIZE (Vertical amplitude), VERT CENT (vertical centring) to compensate for vertical distortion.

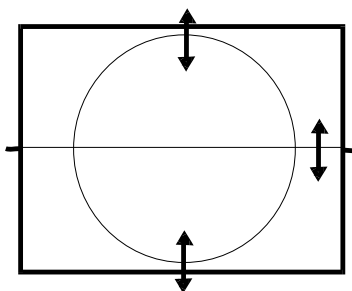

3.4.6 HORIZONTAL PICTURE CENTRING

Adjust HOR CEN (Horizontal centre) to have the picture in the centre of the screen.

3.4.7 EAST / WEST CORRECTION

Adjust the PARABOLA, HOR WIDTH, CORNER, HOR PARAL, EW TRAPEZ, to compensate for geometrical distortion.

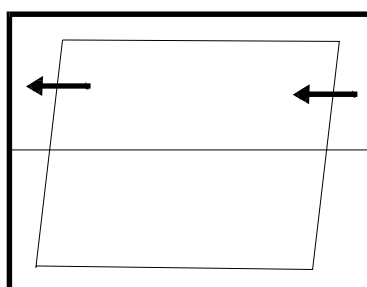

HOR PARAL

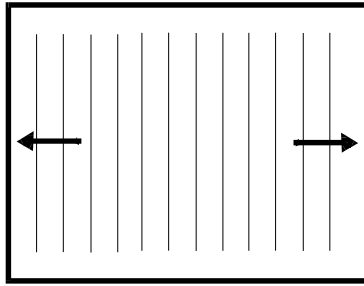

HOR WIDTH
adjust for 93% overscan.

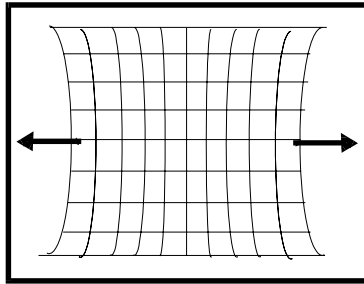

PARABOLA

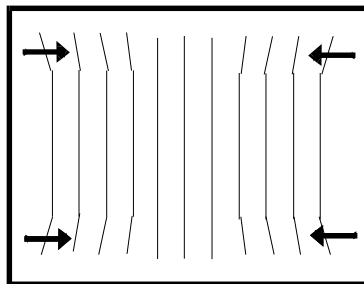

CORNER B & CORNER T

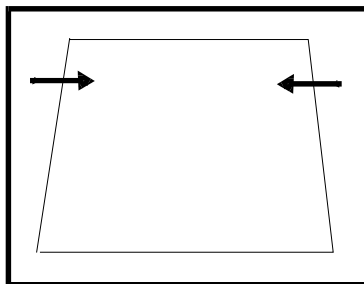

EW TRAPEZ

3.4.8 AGC

- Make sure option bits are correct for the tuner fitted on the chassis (See above how to change option bits).
- Adjust the antenna signal level at $62 \text{ dB}\mu\text{V} \pm 1$
- Tune a colour bar pattern.
- Find the "AGC" item in service mode.
- Press the key "OK" on the remote keypad and wait until AGC level stabilise to the optimum value.
- Alternatively, use "Vol Up/Dwn" keys to adjust manually to the desired Tuner Take Over Point (TOP).

4 IC DESCRIPTION

4.1 TELETEXT DECODER WITH EMBEDDED 8-BIT CONTROLLER

TVText Pro is a 8-bit controller based on a enhanced 8051 core with embedded teletext, On screen Display and TV controller functions.

4.1.1 BLOCK DIAGRAM OF THE SDA55XX

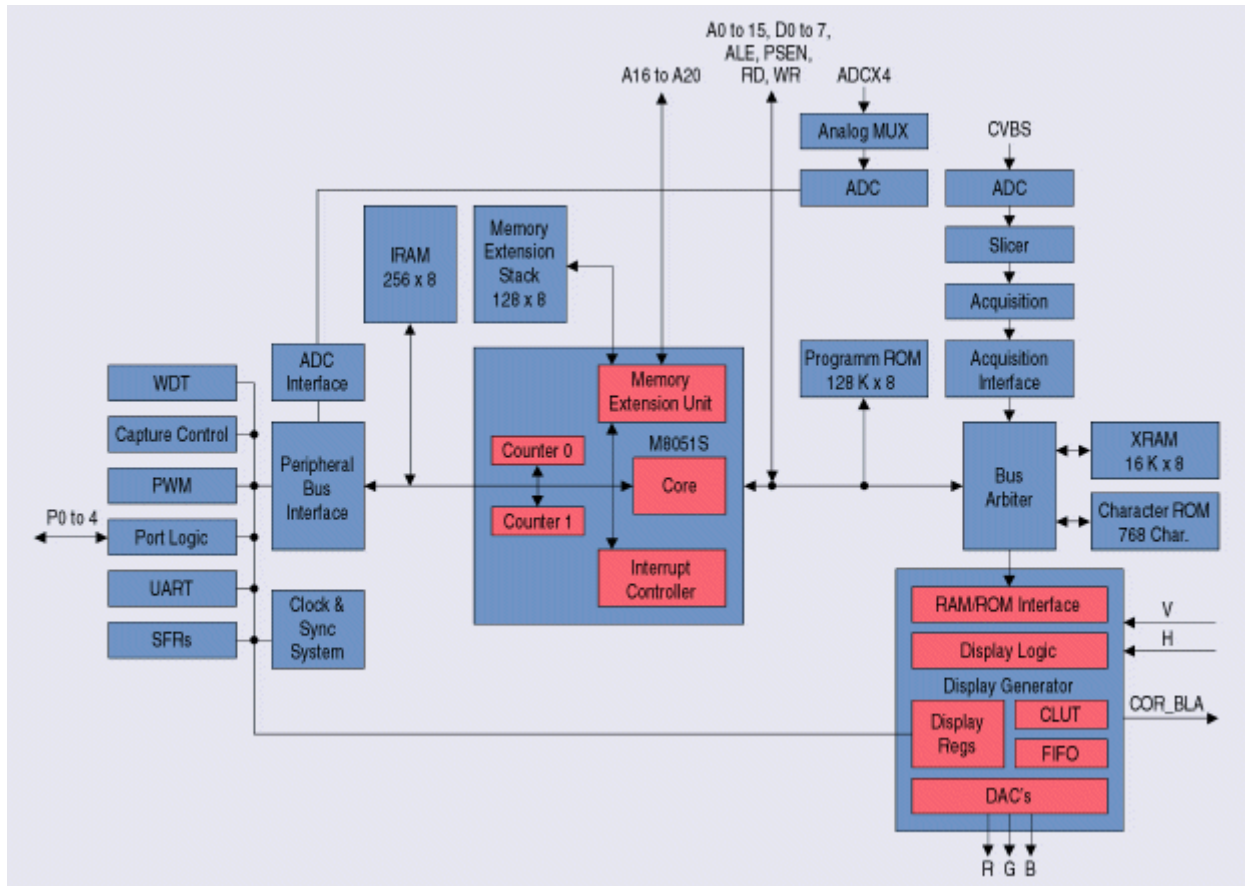

4.1.2 DESCRIPTION

The SDA 55xx is a single chip teletext decoder for decoding World System Teletext data as well as Video Programming System (VPS), Program Delivery Control (PDC), and Wide Screen Signalling (WSS) data used for PAL plus transmissions (line 23).

The device provides an integrated general-purpose, fully 8051-compatible Microcontroller with television specific hardware features. The microcontroller has been enhanced to provide powerful features such as memory banking, data pointers and additional interrupts etc.

The on-chip display unit for displaying Level 1.5 teletext data is also used for customer defined on-screen displays. Internal XRAM consists of 16 Kbytes. Device has an internal ROM of 128 Kbytes.

The SDA 55xx supports a wide range of standards including PAL, NTSC and contains a digital slicer for VPS, WSS, PDC, TTX and Closed Caption, an accelerating acquisition hardware module, a display generator for Level 1.5 TTX data and powerful On screen Display capabilities based on parallel attributes, and Pixel oriented characters (DRCS).

The 8-bit Microcontroller runs at 360 ns. cycle time (min.). Controller with dedicated hardware does most of the internal TTX acquisition processing, transfers data to/from external memory

interface and receives/transmits data via I 2 C-firmware user-interface. The slicer combined with dedicated hardware stores TTX data in a VBI buffer of 1 Kilobyte. The Microcontroller firmware performs all the acquisition tasks (hamming-and parity-checks, page search and evaluation of header control bits) once per field. Additionally, the firmware can provide high-end Teletext-features like Packet-26-handling, FLOF, TOP and list-pages.

4.1.3 IC MARKING AND VERSION

Chassis	IC marking	OSD languages	ATSS countries	Text
CP850FX	SDA555X FL	BULGARIAN, CZECH, GERMAN, DANISH, SPANISH, FRENCH, FINNISH, ENGLISH, GREEK, HUNGARIAN, ITALIAN, NORWEGIAN, DUTCH, POLISH, ROMANIAN, RUSSIAN, SWEDISH, SLOVAKIAN.	Austria, Belgium, Switzerland, Czech Republic, Germany, Denmark, Spain, France, Finland, GB, Greece, Hungary, Italy, Ireland, Norway, Netherlands, Portugal, Poland, Sweden, Slovak Republic, Others	PAN-EUROPEAN LATIN, CYRILLIC, GREEK.

4.1.4 PINNING

PSDIP 52-pin	Pin Name	Type	Short Description
1	SCL	IN/OUT	Software driven I2C bus Clock line
2	SDA	IN/OUT	Software driven I2C bus Data line
3	S/SW2	IN	Slow switching control for SCART 2.
4	S/SW2	IN	(See Microcontroller I/O pin configuration)
5	S/SW1	IN	Slow switching control for SCART 1.
6	S/SW1	IN	(See Microcontroller I/O pin configuration)
7	n.c.		
8	Reset Out	OUT	Driven by controlling software to reset video IC's.
9	VDD2.5	IN	Supply voltage 2.5V
10	VSS	IN	Ground (0V)
11	VDD3.3	IN	Input/Output 3.3V
12	CVBS	IN	CVBS input for the acquisition circuit
13	VDDA2.5	IN	Supply voltage for analog components
14	VSSA	IN	Ground for analog components
15	AFT	IN	ADC input, AFT input
16	AGC	IN	ADC input, for AGC alignment only
17	KEY	IN	ADC input, local key sensing
18	OCP	IN	Switch Off the set when the voltage goes below a trigger level
19	HS	IN	Horizontal sync for OSD/Txt synchronisation
20	VS	IN	Vertical sync for OSD/Txt synchronisation
21	MODESW	OUT	High : Negative video modulation (B, G, D, K,I) Low : Positive video modulation (L / L')
22	L/L'	OUT	High : L', Low : L

23	IR	IN	Remote control signal input
24	INT	IN	Interrupt input from audio processor
25	n.c.		
26	n.c.		
27	n.c.		
28	n.c.		
29	VSS	IN	Ground (0V)
30	VDD3.3	IN	Input/Output 3.3V
31	n.c.		
32	n.c.		
33	RESET	IN	A low level on this pin resets the device.
34	XTAL2	OUT	Output of the inverting oscillator amplifier
35	XTAL1	IN	Input of the inverting oscillator amplifier
36	VSSA	IN	Ground for analog components
37	VDDA2.5	IN	Supply voltage for analog components
38	R OUT	OUT	Red output
39	G OUT	OUT	Green output
40	B OUT	OUT	Blue output
41	BK OUT	OUT	Blanking
42	VDD2.5	IN	Supply voltage 2.5V
43	VSS	IN	Ground (0V)
44	VDD3.3	IN	Input / Output 3.3V
45	n.c.		
46	n.c.		
47	n.c.		
48	AGC	OUT	Tuner TOP adjustment
49	n.c.		
50	n.c.		
51	LED	OUT	High : Green LED, Low : Red LED
52	POWER	OUT	High : SMPS ON, Low : SMPS in stand by

4.2 VSP94x5B (version C4)– OPTIMUS Color Decoder and Scan-Rate Converter

The VSPB family supports 15/32kHz systems and is available with different options. VSP 94x5B has one channel only.

4.2.1 BLOCK DIAGRAM OF THE VSP94x5B

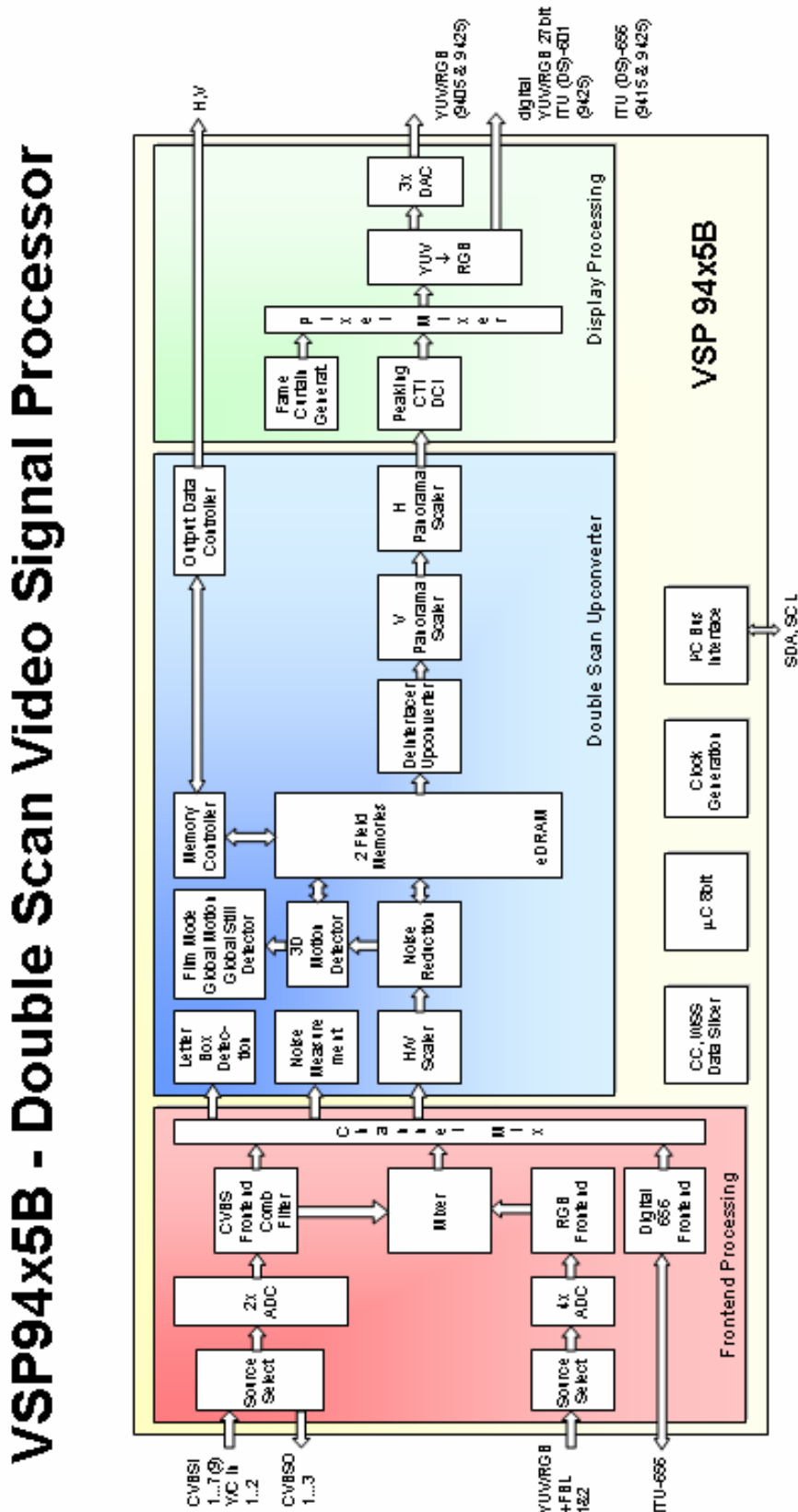

4.2.2 Feature Overview

- Different application modes
 - FSM : Frame based high performance master with PIP
 - SSC : Split screen ("Double Window")
- Data acquisition connectivity
 - Up to seven (VSP 9425B/9427B: nine) CVBS inputs, up to two Y/C inputs
 - Up to three CVBS outputs (even when Y/C input)
 - ITU-R 656 compatible digital input
 - RGB/FBL or YUV or YUV-H-V input
 - 9 bit amplitude resolution for CVBS/Y/C A/D converter
 - 8 bit amplitude resolution for RGB/FBL A/D converter
- Multi-standard color decoder with 4H comb-filter
 - PAL/NTSC/SECAM including all substandard
 - Automatic recognition of chroma standard
 - AGC (Automatic Gain Control)
- Temporal noise reduction for master and slave channel
 - Field or frame based temporal noise reduction for luminance and chrominance
- Pre-scaling of the $1f_H$ signal
 - Horizontal scaling factors: $3/2 \dots 1 \dots 1/28$
 - Vertical scaling factors: $1 \dots 1/30$
- Horizontal and vertical scaling of the $2f_H$ signal
 - Horizontal Scaling factors: $3 \dots 0.75$
 - 5 zone horizontal panorama generator
- Vertical scaling of the $2f_H$ signal
 - Vertical scaling factors: $8 \dots 0.92$
 - 5 zone vertical panorama generator
- Detection circuits
 - Global motion and global still detection
 - Film mode and phase detection (PAL, NTSC; 2-2, 3-2 pull down)
 - Measurement of the noise level (blanking)
 - Detection of letter box formats
- Embedded memory
 - On-chip memory controller
 - Embedded DRAM core for field memory
 - SRAM for delay lines
- Data format 4:2:2
- Data slicer for closed caption ("V-chip") and WSS
- Flexible clock and synchronization concept
 - Horizontal line-locked or free-running mode
 - Vertical locked or free-running mode
- Scan-rate-conversion
 - Motion adaptive frame based 100/120 Hz interlaced scan-rate conversion
 - Motion adaptive frame based 50/60 Hz progressive scan-rate conversion
 - Special treatment for film material ("Inverse 3-2 pull down")
 - Large area and line flicker reduction
 - Simple progressive modes: AB, AA*
 - Simple interlaced modes (100/120 Hz): ABAB, AABB, AAAA, BBBB
 - No scan-rate-conversion modes (50/60 Hz): AB, AA, BB
- Signal manipulations
 - Still field or still frame
 - Insertion of colored background

- 2D and 3D frames for master and slave channel
- Vertical chrominance shift for improved VCR picture quality
- Contrast, brightness and saturation control
- Sharpness improvement
 - Digital color transition improvement (DCTI)
 - Adaptive horizontal and vertical peaking (luminance)
 - Digital luminance transition improvement (DLTI)
 - Digital contrast improvement (DCI, master channel only)
- Three D/A converters
- 9 bit amplitude resolution for YUV, RGB output
- (Nominal) 72 MHz clock frequency with two-fold oversampling
- I2C bus control (400 kHz)
- 1.8 V \pm 5% and 3.3 V \pm 5% supply voltages
- PMQFP80-1 or PMQFP144-1 packages
- Only one crystal necessary for whole IC and all color standards

4.2.3 PINNING

Pin	Name	I/O	Description
1	VDDDACY	S	DAC(Y)
2	AYOUT	O	Y output
3	VSSDAC	S	DAC(Y)
4	VSSD2	S	Supply voltage for digital (0V digital)
5	VDDD2	S	Supply voltage for digital(1.8V digital)
6	SDA	I/O	I2C-Bus data
7	TMS	I	Testmode select (Connected to vdd33)
8	656VIN/BLANK	I/O	Separate V input for 656 / BLANK output
9	656CLK	I/O	Digital input / output clock
10	656IO7	I/O	Digital input / output (MSB)
11	VSSP2	S	Supply voltage for digital (0 V pad)
12	VDDP2	S	Supply voltage for digital (3.3 V pad)
13	SCL	I	I2C-Bus clk
14	V	I	Vertical pulse for RGB input
15	656IO6	I/O	Digital input / output
16	656IO5	I/O	Digital input / output
17	HOUT	O	Horizontal output
18	H50	O	Hout 50 Hz
19	ADR / TDI	I	I2C address / test data in
20	V50	O	Vout 50 Hz
21	656IO4	I/O	Digital input / output
22	656IO3	I/O	Digital input / output
23	VOUT	O	Vertical output
24	RESET	I	Reset input (Reset active low)
25	VDDP3	S	Supply voltage for digital (3.3 V pad)
26	VSSP3	S	Supply voltage for digital (0 V pad)
27	CLKOUT	O	Output clock (27 MHz nom.)
28	VDDD3	S	Supply voltage for DRAM (1.8 V digital)
29	VSSD3	S	Supply voltage for digital (0 V digital)
30	656IO2	I/O	Digital input / output
31	656IO1	I/O	Digital input / output
32	656IO0	I/O	Digital input / output (LSB)

33	VSSD4	S	Supply voltage for digital (0 V digital)
34	VDDD4	S	Supply voltage for digital 1.8 V digital
35	VDDAFBL	S	Supply voltage for FBL (1.8 V)
36	VSSAFBL	S	Supply voltage for FBL (0 V)
37	FBL1	I	Fast Blank input 1 (H1) (Analog input)
38	FBL2	I	Fast Blank input 2 (H2) (Analog input)
39	RIN1	I	R or V in1 (Analog input)
40	GIN1	I	G or Y in1 (Analog input)
41	BIN1	I	B of U in1 (Analog input)
42	VDDARGB	S	Supply voltage for RGB (1.8 V)
43	VDDARGB	S	Supply voltage for RGB (0 V)
44	VDD33RGB	S	Supply voltage RGB (3.3 V)
45	VDD33RGB	S	Supply voltage RGB (0 V)
46	RIN2	I	R or V in2 (Analog input)
47	GIN2	I	G or Y in2 (Analog input)
48	BIN2	I	B of U in2 (Analog input)
49	VSSD5	S	Supply voltage for digital (0 V)
50	VDDAC1	S	Supply voltage CVBS1 (1.8 V) and digital core supply
51	VSSAC1	S	Supply voltage CVBS1 (0 V)
52	CVBS1	I	CVBS input (Analog input)
53	CVBS2	I	CVBS input (Analog input)
54	CVBS3	I	CVBS input (Analog input)
55	CVBS4	I	CVBS input or Y1 (Analog input)
56	CVBS5	I	CVBS input or C1 (Analog input)
57	CVBS6	I	CVBS input or Y2 (Analog input)
58	CVBS7	I	CVBS input or C2 (Analog input)
59	VDD33C	S	Supply voltage CVBS (3.3 V)
60	VSS33C	S	Supply voltage CVBS (0 V)
61	CVBSO3	O	CVBS output 3 (Analog output)
62	CVBSO2	O	CVBS output 2 (Analog output)
63	CVBSO1	O	CVBS output 1 (Analog output)
64	VDDAC2	S	Supply voltage CVBS2 (1.8 V)
65	VSSAC2	S	Supply voltage CVBS2 (0 V)
66	VDDD1	S	Supply voltage for digital (1.8 V digital)
67	VSSD1	S	Supply voltage for digital (0 V digital)
68	VDDAPLL	S	Supply voltage for PLL (1.8 V)
69	XOUT	O	Crystal connection 2
70	XIN	I	Crystal connection 1
71	TCLK	I	Testclock
72	VDDP1	S	Supply voltage for digital (3.3 V pad)
73	VSSP1	S	Supply voltage for digital (0 V pad)
74	656HIN/CLKF20	I/O	Separate H input for 656 / 20.25 clock output
75	VDDDACV	S	DAC (V)
76	AVOUT	O	V output
77	VSSDACV	S	DAC (V)
78	VDDDACU	S	DAC (U)
79	AUOUT	O	U output
80	VSSDACU	S	DAC (U)

4.3 DDP 3315C – DISPLAY AND DEFLECTION PROCESSOR

The DDP 3315C is a mixed-signal single-chip digital display and deflection processor, designed for high-quality backend applications in double scan and HDTV TV sets with 4:3 or 16:9 picture tubes. The interfaces qualify the IC to be combined with state of the art digital scan rate converters, as well as analog HDTV sources. The DDP 3315C contains the entire digital video component, deflection processing, and all analog interfaces to display the picture on a CRT.

4.3.1 BLOCK DIAGRAM OF THE DDP 3315C

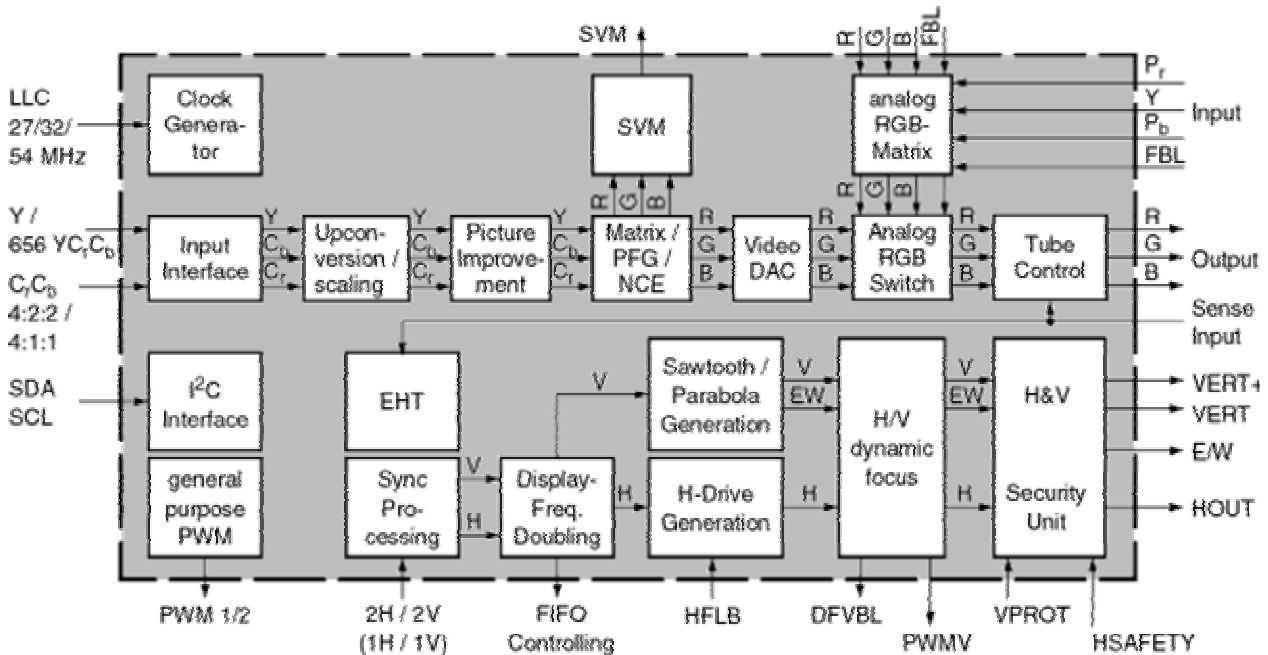

4.3.2 DESCRIPTION

Video Processing

- linear horizontal scaling (0.25 ... 4), as well as nonlinear horizontal scaling “panorama vision”
- dynamic black level expander
- luma sharpness enhancement by dynamic peaking and luma transient improvement (LTI)
- color transient improvement (CTI)
- programmable RGB matrix
- black stretch, blue stretch, gamma correction via programmable Non-linear Colorspace Enhancer (NCE) on RGB
- two analog double scan inputs with fast blank (one RGB and one RGB/YC r C b /YP r P b selectable)
- average and peak beam current limiter
- automatic picture tube adjustment (cutoff, drive)
- histogram calculation

Deflection Processing

- scan velocity modulation output
- digital EHT compensation for vertical / east-west
- soft start/stop of horizontal-drive
- vertical angle and bow correction
- differential vertical outputs
- vertical zoom via deflection adjustment
- horizontal and vertical protection circuit

- horizontal frequency for VGA/SVGA/1080I
- black switch off procedure
- supports horizontal and vertical dynamic focus

Miscellaneous

- selectable ITU-R 601 4:1:1 / 4:2:2 YC_r C_b input at 27/32 MHz or double scan ITU-R 656 input at 54 MHz line-locked clock
- crystal oscillator for horizontal safety
- picture frame generator
- hardware for simple 50/60 Hz to 100/120 Hz conversion (display frequency doubling)
- PQFP80 package, 5 V analog and 3.3 V digital supply

IC architecture

A clock generator converts different external line locked clock rates to a common internal sample rate of ~40 MHz, in order to provide a higher horizontal resolution. The input interface accepts ITU-R 601 at 27 or 32 MHz and ITU-R 656 with encoded or external sync at 54 MHz. The horizontal scaler is used for the scan rate conversion and for the nonlinear aspect ratio conversion as well.

For the picture improvement, luma and chroma are processed separately. The luminance contrast ratio can be extended with a dynamic black level expander. In addition the frequency characteristic is improved by a transient improvement (LTI) and an adaptive dynamic peaking circuit. The peaking adapts to small AC amplitudes of high frequency parts, while large AC amplitudes are processed by the LTI. The chroma signal is enhanced with a transient improvement (CTI) with proper limitation to avoid wrong colours.

The full programmable RGB matrix covers control of colour saturation and temperature. A digital white drive control is used to adjust the white balance and for the beam current limitation to prevent the CRT from over-load. A non-linear colorspace enhancer (NCE) for RGB gives full flexibility for any amplitude characteristic.

High speed 10-bit D/A converters are used to convert digital RGB to analog signals. Separate 9-bit D/A converters control brightness and cutoff. For picture tubes equipped with an appropriate yoke a scan velocity modulation (SVM) signal is calculated using a differentiated luminance signal.

Two analog sources can be inserted in the main RGB, controlled by separate fastblank (FBL) signals. Contrast and brightness are adjusted separately from main RGB. One input is dedicated to RGB for on screen display (OSD). The second input is processed with an analog RGB matrix to insert YC_bC_r/YpbPr or RGB with control of colour saturation and programmable half contrast. The bandwidth of ~30MHz guarantees pixel based graphics to be displayed with full accuracy. All previously mentioned features are implemented in dedicated hardware. An integrated processor controls the horizontal and vertical deflection, tube measurement loops and beam current limitation. It is also used to calculate an amplitude histogram of the displayed image. The horizontal deflection is synchronized with two numeric phase-locked loops (PLL) to the incoming sync. One PLL generates the horizontal timing signals, e.g. blanking and key-clamping. The second PLL adjusts the phase of the horizontal drive pulse with a subpixel accuracy less than 1 ns.

Vertical deflection and east/west correction waveforms are calculated as 6th order polynomials. This allows adjustment of an east/west parabola with trapezoidal, pincushion and an upper/lower corner correction (even for real flat CRT's), as well as a vertical sawtooth with linearity and S-correction. Scaling both waveforms, and limiting to fix amplitudes, performs a vertical zoom or compression of the displayed image. A field and line frequent control loop compensates picture content depending EHT distortions.

4.3.3 PINNING

Pin No.	Pin Name	I/O	Description	Remarks
1	Y6	I	Picture bus Luma	
2	Y7	I	Picture bus Luma (MSB)	
3	656EN	I	Enable 656 input mode	
4	LLC2	I	System clock input	
5	HS	I	Horizontal Sync Input	
6	VS	I	Vertical Sync Input	
7	FREQSEL	I	Selection of H-Drive Frequency Range	
8	CM1	I	Clock select 1	
9	CM0	I	Clock select 0	
10	VS2	I	Additional VSYNC input	
11	XTAL2	O	Analog Crystal Output	
12	XTAL1	I	Analog Crystal Input	
13	NC			
14	GNDP	S	Ground, Output Pin Driver	
15	VSUPP	S	Supply voltage, Output Pin Driver	
16	FIFORRD	O	FIFO Read Counter Reset	
17	FIFORD	O	FIFO Read Enable	
18	FIFOWR	O	FIFO Write Enable	
19	FIFORWR	O	FIFO Write Counter Reset	
20	PWM1	O	I ² C controlled DAC	
21	PWM2	O	I ² C controlled DAC / Tilt output	
22	PWMV	O	I ² C controlled DAC	
23	HOUT	O	Horizontal drive output	
24	VSTBY	S	Standby supply voltage, Hout generation	
25	DFVBL	O	Dynamic focus blanking / horizontal DAF pulse	
26	HSYNC	O	Horizontal sync output	
27	VSYNC	O	Vertical sync output	
28	NC			
29	ASG1	S	Analog Shield Ground	
30	HFBL	I	Horizontal flyback input	
31	SAFETY	I	Safety input	
32	VPROT	I	Vertical protection input	
33	RSW2	O	Range Switch2, measurement ADC	
34	RSW1	I/O	Range Switch1, measurement ADC	
35	SENSE	I	Sense ADC input	
36	GNDM	S	Ground, MADC input	
37	VERT+	O	Differential Vertical Sawtooth Output	
38	VERT-	O	Differential Vertical Sawtooth Output	
39	EW	O	East / West Correction Output	
40	NC			
41	SVM	O	Scan Velocity Modulator	
42	ROUT	O	Analog Output Red	
43	GOUT	O	Analog Output Green	
44	BUT	O	Analog Output Blue	
45	GND0	S	Ground, analog Back End	
46	XREF	I	Reference Input for RGB DAC's	
47	VSUPO	S	Supply voltage, Analog Back End	

48	VRD/BCS	I	DAC Reference, Beam current safety	
49	AGND	S	Analog Ground for Analog Matrix	
50	FBLIN1	I	Fast Blank1input	
51	RIN1	I	Analog Red1input	
52	GIN1	I	Analog Green1 input	
53	BIN1	I	Analog Blue1input	
54	FBLIN2	I	Fast Blank2 input	
55	RIN2 / P _R	I	Analog Red2 input / P _R Input	
56	GIN2 / Y	I	Analog Green2 input / Y Input	
57	BIN2/ P _B	I	Analog Blue2 input / P _B Input	
58	ASG2	S	Analog Shield Ground	
59	HCS	I	Half Contrast	
60	NC			
61	TEST	I		
62	RESQ	I	Reset Input, active low	
63	SCL	I/O	I ² C Bus clock	
64	SDA	I/O	I ² C Bus data	
65	C0	I	Picture Bus Chroma (LSB)	
66	C1	I	Picture Bus Chroma	
67	C2	I	Picture Bus Chroma	
68	C3	I	Picture Bus Chroma	
69	C4	I	Picture Bus Chroma	
70	C5	I	Picture Bus Chroma	
71	C6	I	Picture Bus Chroma	
72	C7	I	Picture Bus Chroma (MSB)	
73	VSUPD	S	Supply voltage, Digital Circuitry	
74	GNDD	S	Ground, Digital Circuitry	
75	Y0	I	Picture Bus Luma (LSB)	
76	Y1	I	Picture Bus Luma	
77	Y2	I	Picture Bus Luma	
78	Y3	I	Picture Bus Luma	
79	Y4	I	Picture Bus Luma	
80	Y5	I	Picture Bus Luma	

4.4 MSP341X MULTISTANDARD SOUND PROCESSOR

The MSP 341x is designed as a single-chip Multistandard Sound Processor for applications in analogue and digital TV sets, video recorders, and PC cards.

The MSP3411 has all functions of MSP3410 with the addition of a virtual surround sound features.

Surround sound can be reproduced to a certain extent with two loudspeakers. The MSP3411 includes virtualizer algorithm "3D Panorama" which has been approved by the Dolby laboratories for compliance with the "Virtual Dolby Surround" technology. In addition, the MSP3411 includes Micronas "Panorama" algorithm.

MSP 341x features:

- sound IF input
- No external filters required
- Stereo baseband input via integrated AD converters
- Two pairs of DA converters
- Two carrier FM or NICAM processing
- AVC : Automatic Volume Correction
- Bass, treble, volume processing
- Full SCART in/out matrix without restrictions
- Improved FM-identification
- Demodulator short programming
- Auto-detection for terrestrial TV - sound standards
- Precise bit-error rate indication
- Automatic switching from NICAM to FM/AM or vice versa
- Improved NICAM synchronisation algorithm
- Improved carrier mute algorithm
- Improved AM-demodulation
- Reduction of necessary controlling
- Less external components

4.4.1 BASIC FEATURES OF THE MSP 341X

4.4.1.1 Demodulator & NICAM Decoder Section

The MSP 341x is designed to simultaneously perform digital demodulation and decoding of NICAM-coded TV stereo sound, as well as demodulation of FM or AM mono TV sound. Alternatively, two carrier FM systems according to the German terrestrial specs can be processed with the MSP 341x.

The MSP 341x facilitates profitable multistandard capability, offering the following advantages:

- Automatic Gain Control (AGC) for analogue input: input range: 0.10 - 3 Vpp
- integrated A/D converter for sound-IF input
- all demodulation and filtering is performed on chip and is individually programmable
- easy realisation of all digital NICAM standards (B/G, I, L and D/K)
- FM-demodulation of all terrestrial standards (include identification decoding)
- no external filter hardware is required
- only one crystal clock (18.432 MHz) is necessary
- high deviation FM-mono mode (max. deviation: approx. ± 360 kHz)

4.4.1.2 DSP-Section (Audio Baseband Processing)

- flexible selection of audio sources to be processed
- performance of terrestrial de-emphasise systems (FM, NICAM)
- digitally performed FM-identification decoding and de-matrixing
- digital baseband processing: volume, bass, treble
- simple controlling of volume, bass, treble

4.4.1.3 Analogue Section

- two selectable analogue pairs of audio baseband input (= two SCART inputs) input level: <2 V RMS, input impedance: >25 k Ω
- one selectable analogue mono input (i.e. AM sound): Not used in this chassis
- two high-quality A/D converters, S/N-Ratio: >85 dB
- 20 Hz to 20 kHz bandwidth for SCART-to-SCART copy facilities
- loudspeaker: one pair of four-fold oversampled D/A converters. Output level per channel: max. 1.4 VRMS output resistance: max. 5 k Ω . S/N-ratio: >85 dB at maximum volume max. noise voltage in mute mode: < 10 μ V (BW: 20 Hz... 16 kHz)
- one pair of four-fold oversampled D/A converters supplying a pair of SCART-outputs. Output level per channel: max. 2 V RMS, output resistance: max. 0.5 k Ω , S/N-Ratio: >85 dB (20 Hz... 16 kHz)

4.4.1.4 NICAM & FM/AM-Mono

According to the British, Scandinavian, Spanish, and French TV-standards, high-quality stereo sound is transmitted digitally. The systems allow two high-quality digital sound channels to be added to the already existing FM/AM-channel. The sound coding follows the format of the so-called Near Instantaneous Companding System (NICAM 728). Transmission is performed using Differential Quadrature Phase Shift Keying (DQPSK). Table below offers an overview of the modulation parameters.

In the case of NICAM/FM (AM) mode, there are three different audio channels available: NICAM A, NICAM B, and FM/AM-mono. NICAM A and B may belong either to a stereo or to a dual language transmission. Information about operation mode and about the quality of the NICAM signal can be read by the controlling software via the control bus. In the case of low quality (high bit error rate), the controlling software may decide to switch to the analogue FM/AM-mono sound. Alternatively, an automatic NICAM-FM/AM switching may be applied.

4.4.1.5 German 2-Carrier System (DUAL FM System)

Since September 1981, stereo and dual sound programs have been transmitted in Germany using the 2-carrier system. Sound transmission consists of the already existing first sound carrier and a second sound carrier additionally containing an identification signal. More details of this standard are given in Tables below. For D/K very similar system is used.

TV standards

TV system	Position of sound carrier (MHz)	Sound modulation	Colour system	Country
B/G	5.5 / 5.7421875	FM Stereo	PAL	GERMANY
B/G	5.5 / 5.85	FM-Mono / NICAM	PAL	Scandinavia, Spain
L	6.5 / 5.85	AM – Mono / NICAM	SECAM-L	France

I	6.0 / 6.552	FM-Mono / NICAM	PAL	UK
D/K	6.5 / 6.2578125 D/K1 6.5 / 6.7421875 D/K2 6.5 / 5.85 D/K-NICAM	FM Stereo FM-Mono / NICAM	SECAM- East	USSR Hungary

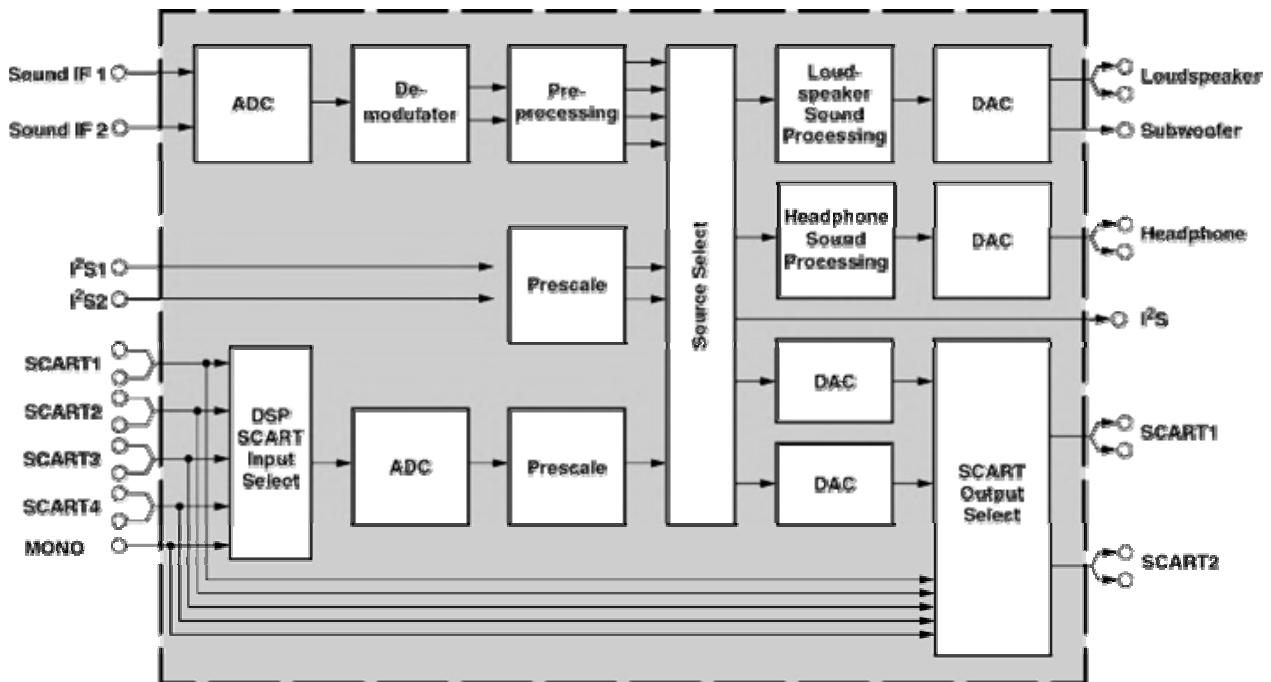

Architecture of MSP341x

Pin connections and short description

Pin No.	Pin Name	Type	Short description
1	NC		Not Connected
2	NC		Not Connected
3	NC		Not Connected
4	INT	Out	Interrupt out
5	MUTE	Out	Mute out
6	ADR_SEL	In	I2C bus Address select
7	STANDBYQ	In	Standby (Low-active)
8	NC		Not Connected
9	I2C_CL	In / Out	I2C Clock
10	I2C_DA	In / Out	I2C data
11	NC		Not Connected
12	NC		Not Connected
13	NC		Not Connected
14	NC		Not Connected
15	NC		Not Connected
16	NC		Not Connected
17	NC		Not Connected
18	DVSUP		Digital power supply +5V
19	DVSS		Digital Ground
20	NC		Not Connected
21	NC		Not Connected
22	NC		Not Connected

23	NC		Not Connected
24	RESETQ	In	Power-On-reset
25	DACA_R	Out	Headphone out right
26	DACA_L	Out	Headphone out left
27	VREF2		Reference ground 2 high voltage part
28	DACM_R	Out	Loudspeaker out Right
29	DACM_L	Out	Loudspeaker out Left
30	NC		Not Connected
31	NC		Not Connected
32	NC		Not Connected
33	SC2_OUT_R	Out	Scart output 2 right
34	SC2_OUT_L	Out	Scart output 2 left
35	VREF1		Reference ground 1 high voltage part
36	SC1_OUT_R	Out	Scart output 1, right
37	SC1_OUT_L	Out	Scart output 1, left
38	CAPL_A		Volume capacitor AUX
39	AHVSUP		Analog power supply 8.0V
40	CAPL_M		Volume capacitor MAIN
41	AHVSS		Analog ground
42	AGNDC		Analog reference voltage high voltage part
43	NC		Not Connected
44	NC		Not Connected
45	NC		Not Connected
46	SC3_IN_L	In	Scart input 3 in, left
47	SC3_IN_R	In	Scart input 3 in, right
48	ASG2		Analog Shield Ground 2
49	SC2_IN_L	In	Scart input 2 in, left
50	SC2_IN_R	In	Scart input 2 in, right
51	ASG1		Analog Shield Ground 1
52	SC1_IN_L	In	Scart input 1 in, left
53	SC1_IN_R	In	Scart input 1 in, right
54	VREFTOP		Reference voltage IF A/D converter
55	MONO_IN	In	Mono input
56	AVSS		Analog ground
57	AVSUP		Analog power supply
58	ANA_IN1+	In	IF input 1
59	ANA_IN1-	In	IF common
60	NC		Not Connected
61	TESTEN	In	Test pin
62	XTAL_IN	In	Crystal oscillator
63	XTAL_OUT	Out	Crystal oscillator
64	NC		Test pin

4.5 TDA4470 - MULTISTANDARD VIDEO-IF AND QUASI PARALLEL SOUND PROCESSOR

4.5.1 DESCRIPTION

The TDA4470 is an integrated bipolar circuit for multi-standard video/sound IF (VIF/SIF) signal processing in TV/VCR and multimedia applications. The circuit processes all TV video IF signals with negative modulation (e.g., B/G standard), positive modulation (e.g., L standard) and the AM, FM/NICAM sound IF signals.

4.5.2 FEATURES

- 5 V supply voltage; low power consumption.
- Active carrier generation by FPLL principle (frequency-phase-locked-loop) for true synchronous demodulation.
- Very linear video demodulation, good pulse response and excellent intermodulation figures.
- VCO circuit operates at picture carrier frequency, the VCO frequency is switchable for L'-mode
- Alignment-free AFC without external reference circuit, polarity of the AFC curve is switchable.
- VIF-AGC for negative modulated signals (peak sync. detection) and for positive modulation (peak white/black level detector).
- Tuner AGC with adjustable take over point.
- Alignment-free quasi parallel sound (QPS) mixer for FM/NICAM sound IF signals.
- Inter-carrier output signal is gain controlled (necessary for digital sound processing).
- Complete alignment-free AM demodulator with gain controlled AF output.
- Separate SIF-AGC with average detection
- Two independent SIF inputs
- Parallel operation of the AM demodulator and QPS mixer (for NICAM-L stereo sound).

4.5.3 PINNING

Pin	Symbol	Function
1, 2	$V_{i, SIF1}$	SIF1 input (symmetrical)
3	V_{SW}	Input selector switch
4, 9, 16	GND	Ground
5	V_{AGC}	SIF – AGC (time constant)
6, 7	$V_{i, VIF}$	VIF input (symmetrical)
8	C_{AGC}	VIF – AGC (time constant)
10	R_{TOP}	Take Over Point, tuner AGC
11	I_{tun}	Tuner AGC output current
12	$V_{O, VID}$	Video output
13	V_{SW}	Standard switch
14	V_{SW}	L' switch
15	C_{bl}	Black level capacitor
17	C_{ref}	Internal reference voltage
18	LF	Loop Filter
19	V_{SW}	AFC switch
20, 21	V_{VCO}	VCO circuit
22	V_{AFC}	AFC output
23	V_S	Supply voltage
24	$V_{O, FM}$	Inter-carrier output
25	$V_{O, AM}$	AF output – AM sound
26	R_{comp}	Offset compensation
27, 28	$V_{i, SIF2}$	SIF2 input (symmetrical)

4.5.4 BLOCK DIAGRAM

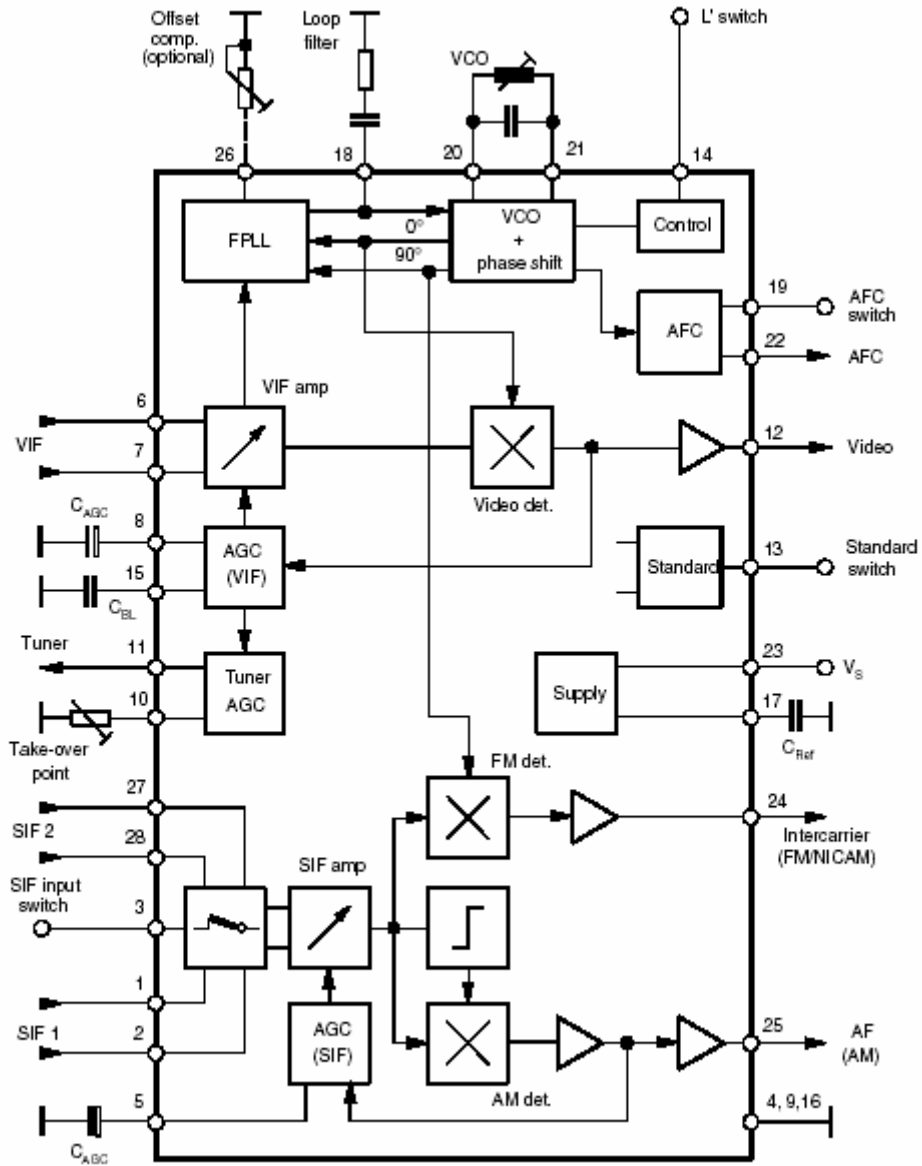

4.6 TDA8946J STEREO AUDIO AMPLIFIER

The TDA 8946J is a dual-channel audio power amplifier with an output power of 2 x 15 W at an 8 Ω load and a 18 V supply. The circuit contains two Bridge Tied Load (BTL) amplifiers with an all-NPN output stage and standby/mute logic. The TDA8946J comes in a 17-pin DIL-bent-SIL(DBS) power package. The TDA8946J is printed-circuit board compatible with all other types in the TDA894x family.

One PCB footprint accommodates both the mono and the stereo products.

4.6.1 FEATURES

- Few external components
- Fixed gain
- Standby and mute mode
- No on/off switching plops
- Low standby current
- High supply voltage ripple rejection
- Outputs short-circuit protected to ground, supply and across the load
- Thermally protected
- Printed-circuit board compatible

Pin description

Pin	Symbol	Description
1	OUT1-	negative loudspeaker terminal 1
2	GND1	ground channel 1
3	Vcc1	supply voltage channel 1
4	OUT1+	positive loudspeaker terminal 1
5	n.c.	not connected
6	IN1+	positive input1
7	n.c.	not connected
8	IN1-	negative input1
9	IN2-	negative input2
10	MODE	mode selection input
11	SVR	half supply voltage decoupling (ripple rejection)
12	IN2+	positive input2

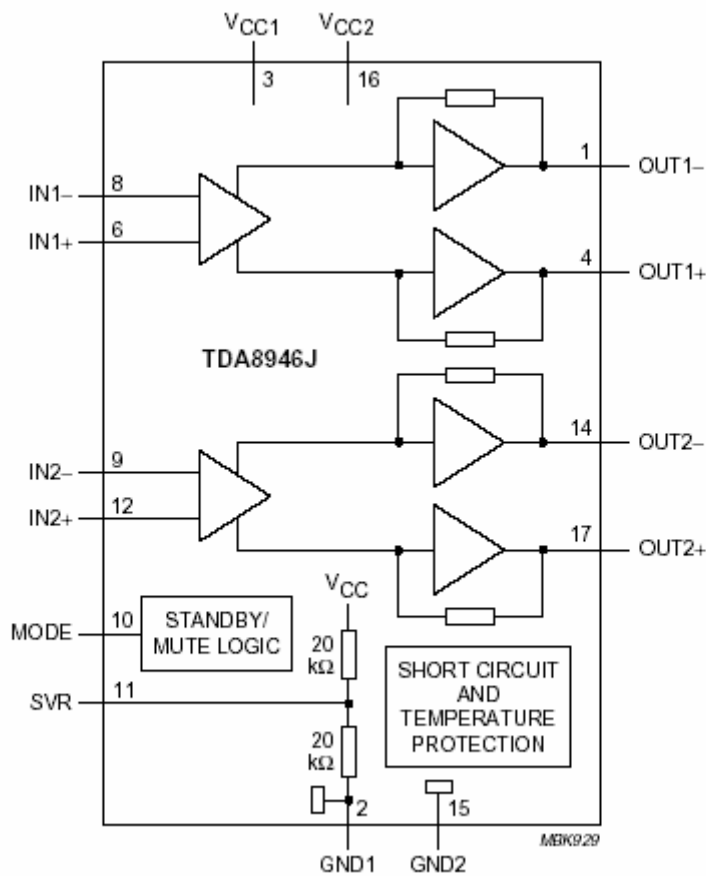
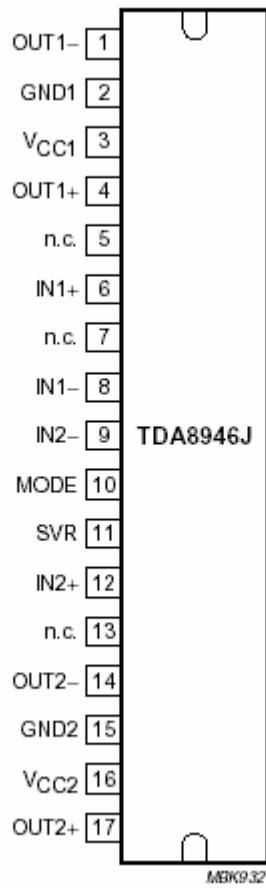

Block diagram TDA8946J

4.7 TDA8358J VERTICAL AMPLIFIER

The TDA8358J are power circuit for use in 90° and 110° colour deflection systems for field frequencies of 25 to 200Hz field frequencies, and for 4:3 and 16:9 picture tubes. The IC contains a vertical deflection output circuit, operating as a high efficiency class G system. The full bridge output circuit allows DC coupling of the deflection coil in combination with single positive supply voltages.

The east-west output stage is able to supply the sink current for a diode modulator circuit.

The IC is constructed in a Low Voltage DMOS(LVDMOS) process that combines Bipolar, CMOS and DMOS devices. MOS transistors are used in the output stage because of the absence of second breakdown.

4.7.1 FEATURES

- Few external components
- Highly efficiency fully DC-coupled vertical output bridge circuit
- Vertical flyback switch with short rise and fall times
- Built-in guard circuit
- Thermal protection circuit
- Improved EMC performance due to differential inputs
- East-West output stage

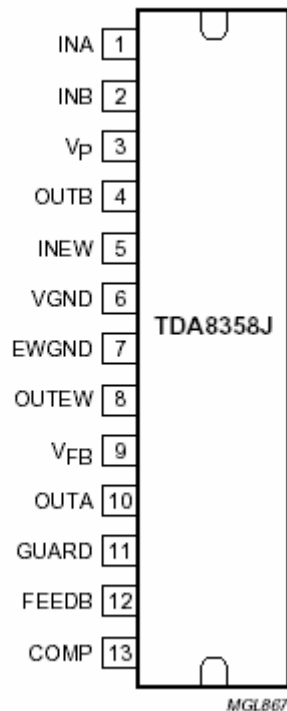

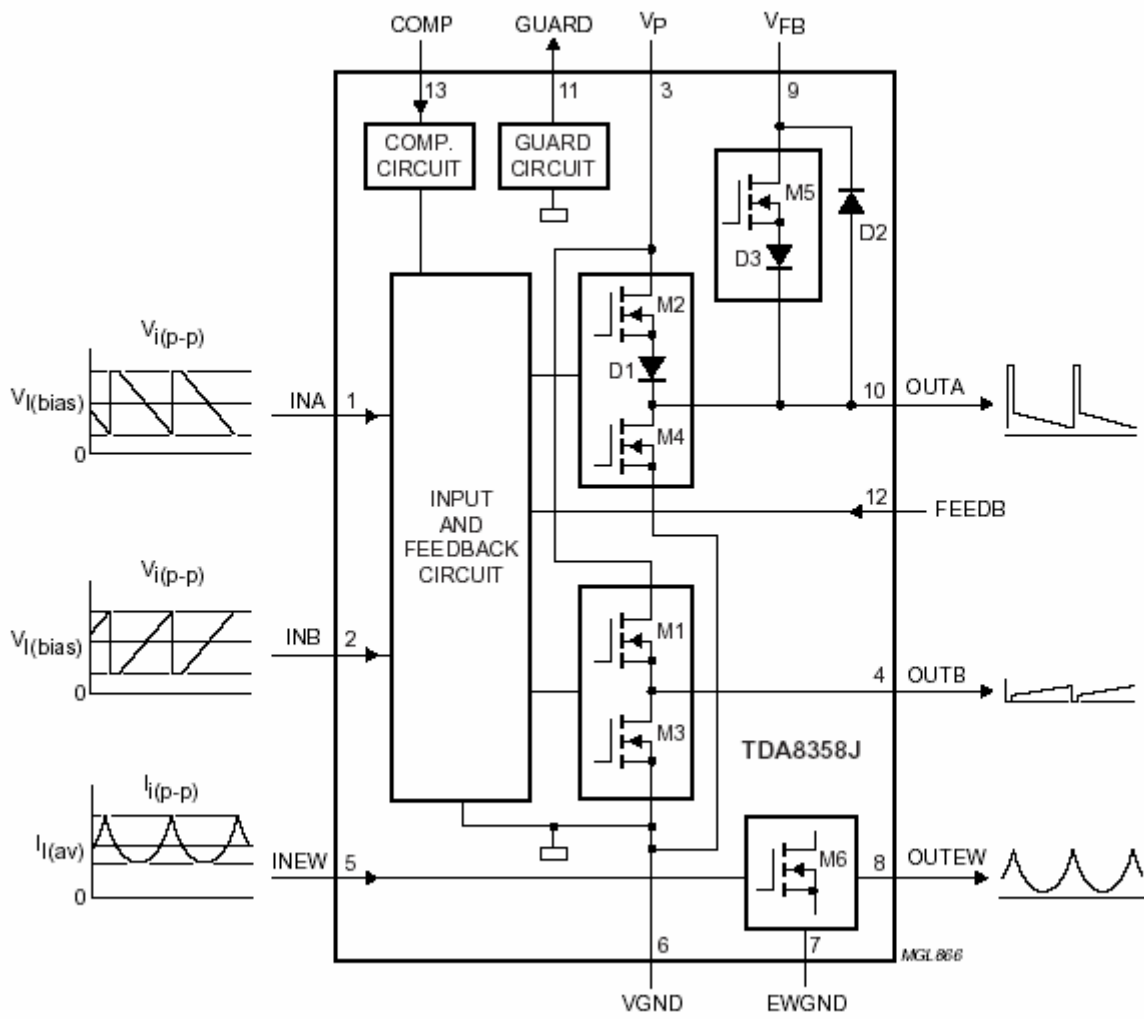

4.8 TDA6108JF

The TDA6108JF includes three video output amplifiers in one plastic DIL-Bent-SIL 9-pin medium power(DBS9MPF) package(SOT111-1), using high voltage DMOS technology, and is intended to drive the three cathodes of a colour CRT directly. To obtain maximum performance, the amplifier should be used with black-current control.

Features

- Typical bandwidth of 9.0 MHz for an output signal of 60 Vpp
- High slew rate of 1850V/ μ s
- No external components required
- Very simple application
- Single supply voltage of 200V
- Internal reference voltage of 2.5 V
- Fixed gain of 51.
- Black-current stabilisation (BCS) circuit
- Thermal protection

Pin description

Pin	Symbol	Description
1	$V_{i(1)}$	inverting input 1
2	$V_{i(2)}$	inverting input 2
3	$V_{i(3)}$	inverting input 3
4	GND	ground (fin)
5	I_{om}	black current measurement output
6	V_{DD}	supply voltage
7	$V_{OC(3)}$	cathode output 3
8	$V_{OC(2)}$	cathode output 2
9	$V_{OC(1)}$	cathode output 1

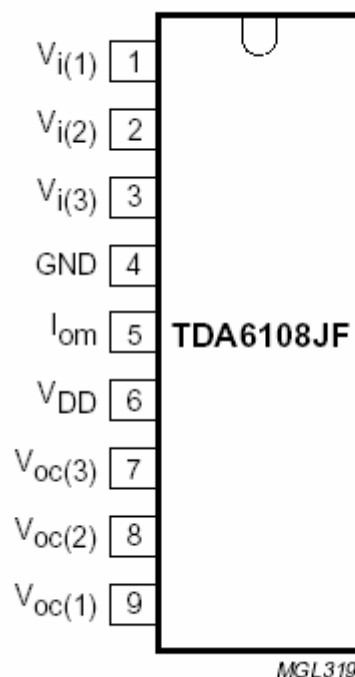

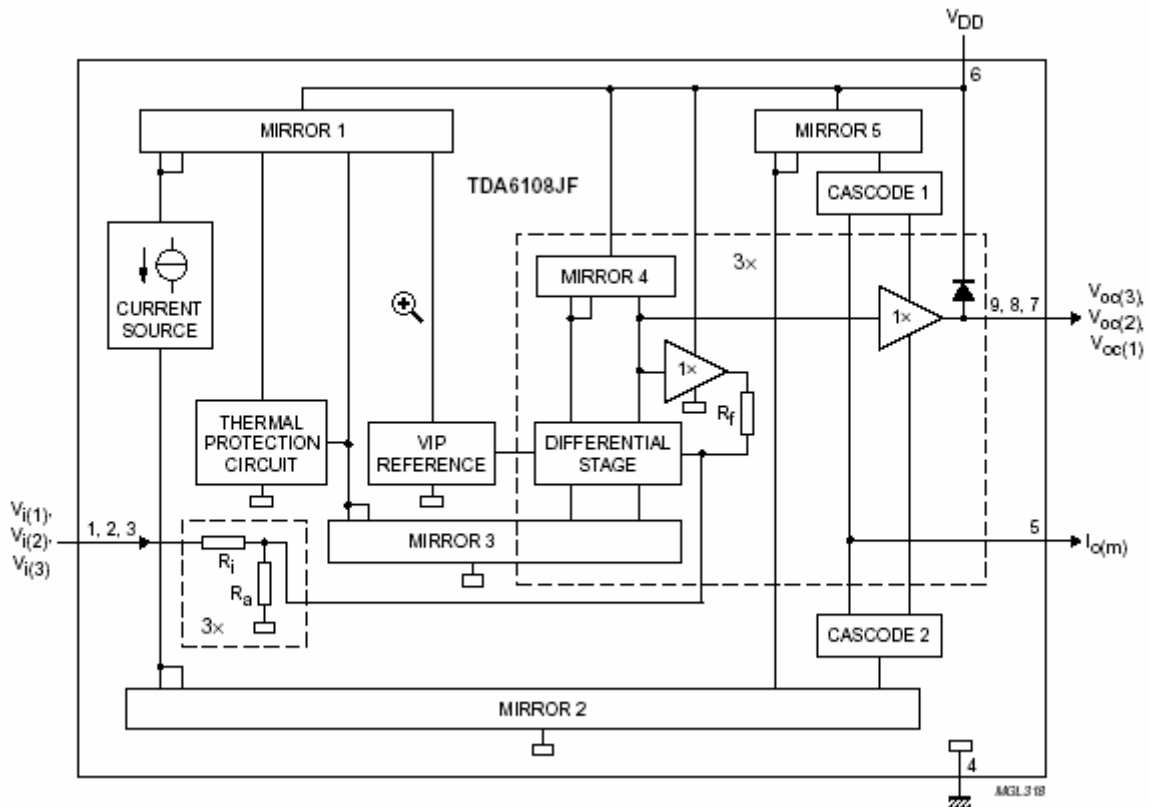

Block diagram TDA6108JF

4.9 24C16 - 16 KB EEPROM

Features :

- 16 Kbit serial I2C bus EEPROM
- Single supply voltage : 4.5 V to 5.5 V
- 1 Million Erase/Write cycles (minimum)
- 40 year data retention (minimum)

Pin description

Pin No.	Name	Description
1, 2, 3	E0, E1, E2	Device address – not used
5	SDA	Serial Data/Address Input/Output
6	SCL	Serial clock
7	WC	Write control
8	Vcc	Supply voltage
4	Vss	Ground

The memory device is compatible with the I2C memory standard. This is a two wire serial interface that uses a bi-directional data bus and serial clock. The memory carries a built-in 4-bit unique device type identifier code (1010) in accordance with the I2C bus definition.

Serial Clock (SCL)

The SCL input is used to strobe all data in and out of the memory.

Serial Data (SDA)

The SDA pin is bi-directional, and is used to transfer data in or out of the memory

4.10 STR – W6754

4.10.1 GENERAL DESCRIPTION

The STR-W6700 series is a Hybrid IC (HIC) designed for Quasi-Resonant type Switching Mold Power Supply built-in a Power MOSFET and Control IC.

4.10.2 FEATURES

- operation mode turns blocking oscillation by reducing output voltage at stand-by mode.
- In addition to the existing Quasi-Resonant Operation, the Bottom-Skip Function is added in order to be efficient from light to medium load.
- Soft-Start Operation is provided at the SMPS start-up.
- Switching noise is reduced by Step-Drive Function.
- Avalanche energy of the MOSFET is guaranteed.
- Overcurrent Protection (OCP), Overvoltage Protection (OVP), Overload Protection (OLP), and Maximum ON-Time control circuits are incorporated.
- It is possible to save the SMPS design time by utilizing the present designs and evaluation processes.

4.10.3 BLOCK DIAGRAM

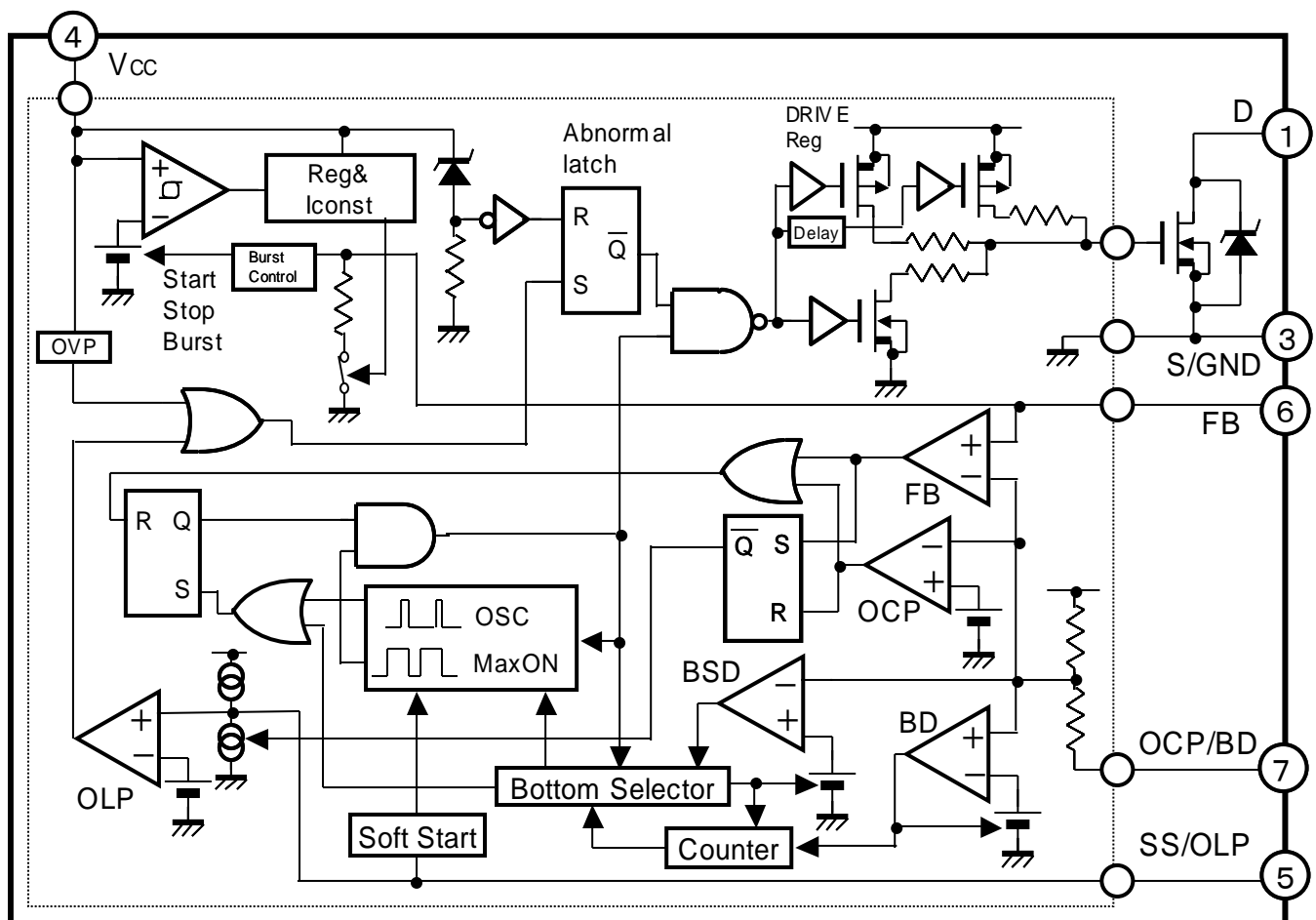

4.10.4 PIN DESCRIPTION

Pin No.	Symbols	Terminal Descriptions	Functions
1	D	Drain Terminal	MOSFET Drain
2	—	Source/Grand Terminal	MOSFET Source and Ground
3	S/GND		
4	V _{CC}	Power Supply Terminal	Control Circuit Power Supply Input
5	SS/OLP	Delay at Overload/Soft-Start set up Terminal	Overload Protection and Soft- Start Operation Time set up
6	FB	Feedback Terminal	Constant Voltage Control Signal Input, Blocking Oscillation Control
7	OCP/BD	Overcurrent Protection Input/Bottom Detection Terminal	Overcurrent Detection Signal Input / Bottom Detection Signal Input

4.10.5 MOSFET ELECTRICAL CHARACTERISTICS

Parameters	Terminal	Symbols	Ratings			Units	Conditions
			MIN	TYP	MAX		
Drain-Source Voltage ※7	1 - 3	V _{DSS}	650	—	—	V	※6
Drain Leakage Current	1 - 3	I _{DSS}	—	—	300	μA	
ON Resistance ※7	1 - 3	R _{DS(ON)}	—	—	0.73	Ω	
Switching Time	1 - 3	t _f	—	—		Nsec	
Thermal Resistance ※7	—	Θ _{ch-F}	—	—		°C/W	Channel – Internal Frame

4.10.6 ELECTRICAL CHARACTERISTICS

Parameters	Terminal	Symbols	Ratings			Units
			MIN	TYP	MAX	
Power Supply Start-up Operation						
Operation Start-up Voltage	4 - 3	VCC(ON)		18.2		V
Operation Stop Voltage	4 - 3	VCC(OFF)		9.6		V
Operation Circuit Current	4 - 3	ICC(ON)	—	—	6	mA
Non Operation Circuit Current	4 - 3	ICC(OFF)	—	—	100	μA
Oscillation Frequency	1 - 3	fOSC		22		kHz
Soft-Start Operation Stop Voltage	5 - 3	VSSOLP(SS)		1		V
Soft-Start Operation Charging Current	5 - 3	ISSOLP(SS)		-450		μA
Normal Operation						
Overcurrent Detection Threshold Voltage	7 - 3	VOCPBD(LIM)		-0.95		V
Bottom-Skip Operation Threshold Voltage 1	7 - 3	VOCPBD(BS1)		-0.66		V
Bottom-Skip Operation Threshold Voltage 2	7 - 3	VOCPBD(BS2)		-0.44		V
OCP/BD Terminal Outflow Current	7 - 3	IOCPBD				μA
Quasi-Resonant Operation Threshold Voltage 1	7 - 3	VOCPBD(TH1)		0.4		V
Quasi-Resonant Operation Threshold Voltage 2	7 - 3	VOCPBD(TH2)		0.8		V
Minimum Quasi-Resonant Signal Input Time	7 - 3	TOFF(MIN)	—	—	1	μsec
FB Terminal Threshold Voltage	6 - 3	VFB(OFF)		1.5		V
FB Terminal Inflow Current (Normal Operation)	6 - 3	IFB(ON)				mA
Stand-by Operation						
Stand-by Operation Start-up Power Supply Voltage	4 - 3	VCC(S)		11.2		V
Stand-by Power Supply Voltage Interval	4 - 3	VCC(SK)		1.5		V
Stand-by Non-Operational Circuit Current	4 - 3	ICC(S)		30		μA
FB Stand-by Operation Threshold Voltage	6 - 3	VFB(S)				V
FB Terminal Inflow Current (Stand-by)	6 - 3	IFB(S)				μA
Minimum ON Time	1 - 3	TON(MIN)		1		μsec
Protection Operation						
Maximum ON Time	1 - 3	TON(MAX)		34		μS
OLP Operation Threshold Voltage	5 - 3	VSSOLP(OLP)		5		V
OLP Operation Charging Current	5 - 3	ISSOLP(OLP)		-10		μA
Normal Operation Discharging Current	5 - 3	ISSOLP(NOR)		40		μA
OLP Delay Time	1 - 3	TOLP				ms
OVP Operational Voltage	4 - 3	VCC(OVP)		27.5		V
Latch Circuit Holding Current ※10	4 - 3	ICC(H)	—	—	150	μA
Latch Circuit Releasing Power Supply Voltage ※10	4 - 3	VCC(La.OFF)		7.3		V

5 CP-850FX CHASSIS DESCRIPTION

5.1 POWER SUPPLY BLOCK DIAGRAM

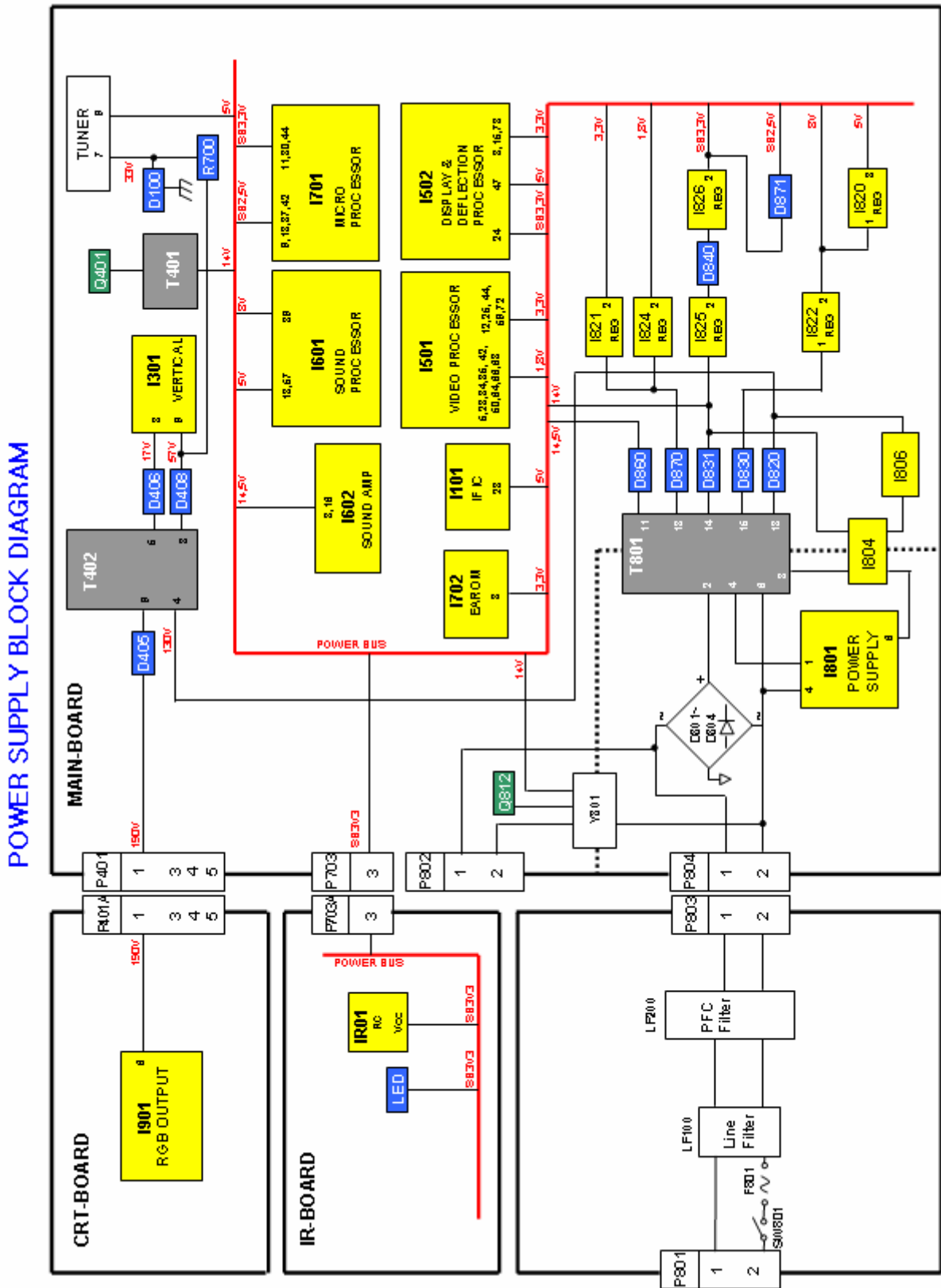

5.2 VIDEO & STEREO AUDIO BLOCK DIAGRAM

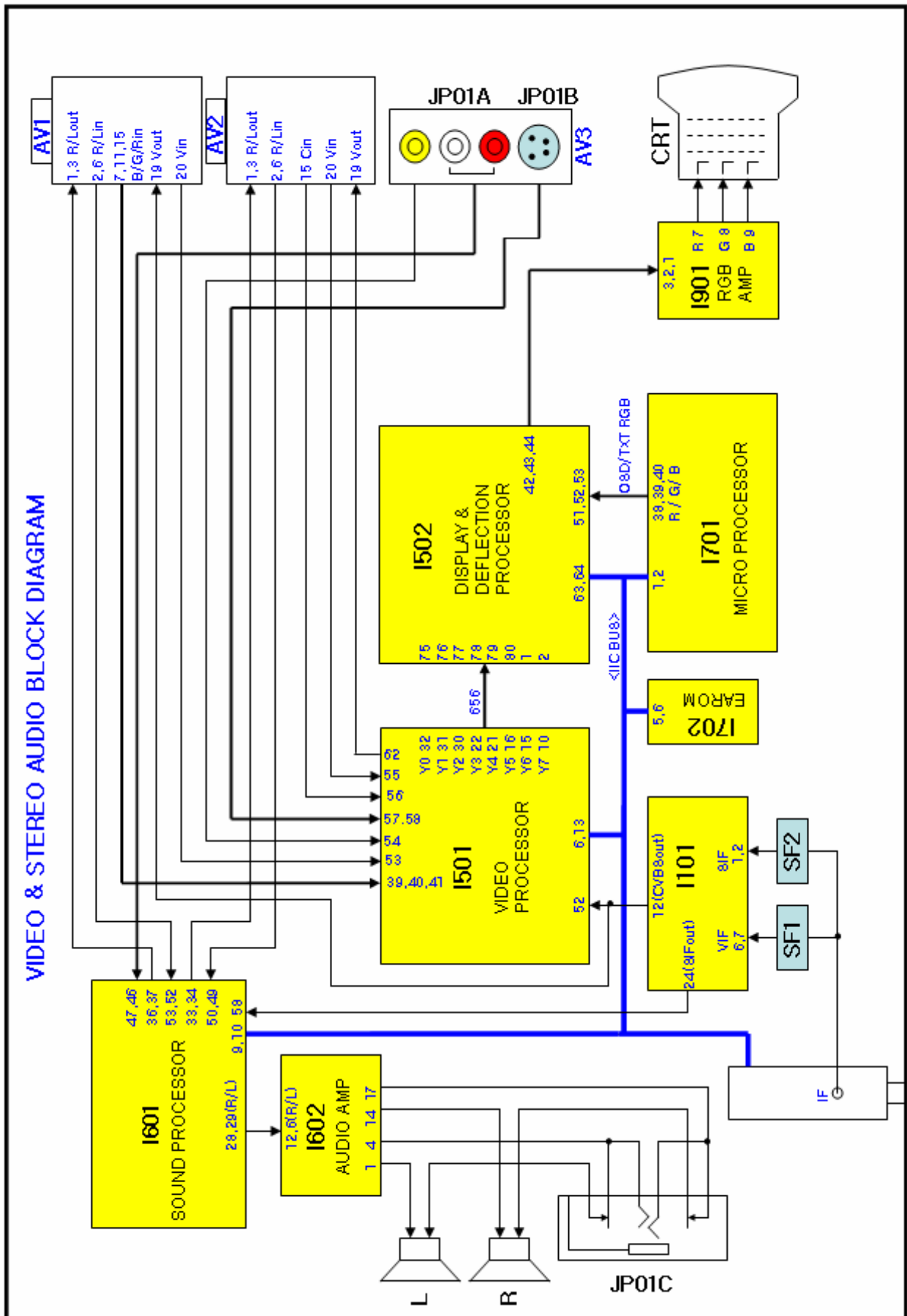

5.3 IF SECTION

5.3.1 BLOCK DIAGRAM

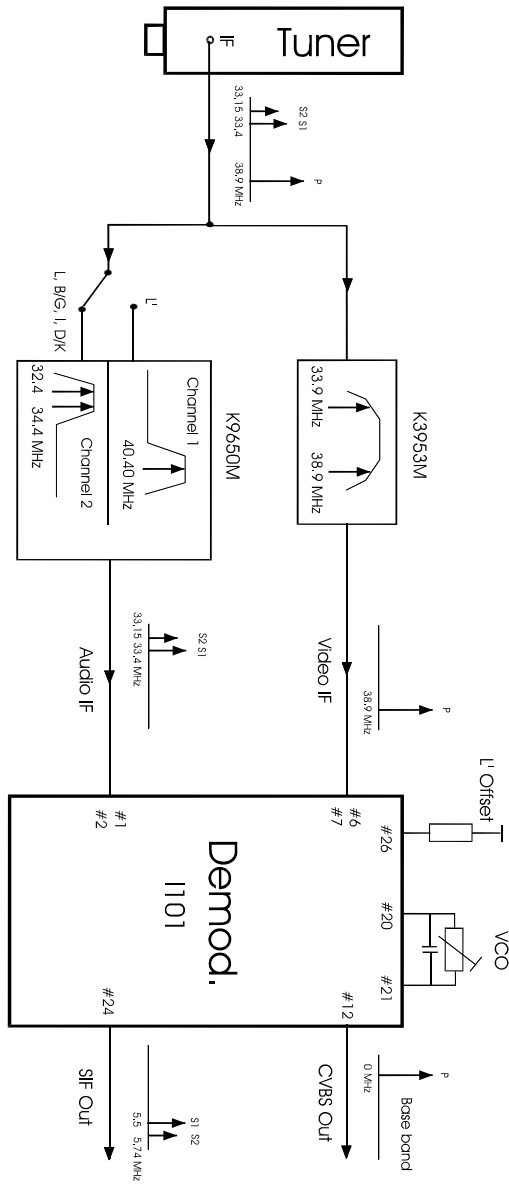

5.3.2 VISION IF AMPLIFIER

The video IF signal (VIF) is fed through a SAW filter to the differential input (Pin 6-7) of the VIF amplifier. This amplifier consists of three AC-coupled amplifier stages. Each differential amplifier is gain controlled by the automatic gain control (VIF-AGC). The output signal of the VIF amplifier is applied to the FPLL carrier generation and the video demodulator.

SAW filters

Ref.	Standard	Features
K3953M	B/G - D/K - I - L/L'	<ul style="list-style-type: none"> ▪ IF filter for video application ▪ TV IF filter with Nyquist slopes at 33.9 MHz and 38.9 MHz ▪ Constant group delay
K9650M	B/G - D/K - I - L/L'	<ul style="list-style-type: none"> ▪ IF filter for audio application ▪ TV IF audio filter with two channels ▪ Channel 1 (L') with one pass band for sound carrier at 40.40 MHz ▪ Channel 2 (L, D/K, I, B/G) with one pass band for sound carriers between 32.40 MHz and 33.40 MHz

5.3.3 TUNER-AND VIF-AGC

At Pin 8, the VIF-AGC charges/discharges the AGC capacitor to generate a control voltage for setting the gain of the VIF amplifier and tuner in order to keep the video output signal at a constant level. Therefore, in the case of all negative modulated signals (e.g., B/G standard) the sync. level of the demodulated video signal is the criterion for a fast charge/discharge of the AGC capacitor. For positive modulation (e.g., L standard) the peak white level of video signal controls the charge current. In order to reduce reaction time for positive modulation, where a large time constant is needed, an additional black level detector controls the discharge current in the event of decreasing VIF input signal. The control voltage (AGC voltage at Pin 8) is transferred to an internal control signal, and is fed to the tuner AGC to generate the tuner AGC current at Pin 11 (open collector output). The take over point of the tuner AGC is adjusted at Pin 10 by an external dc voltage from microprocessor. A PWM output from microcontroller is low pass filtered for this AGC control. See also "AGC" adjustment for details on how to align TOP in SERVICE mode.

5.3.4 FPLL, VCO AND AFC

The FPLL circuit (frequency phase locked loop) consists of a frequency and phase detector to generate the control voltage for the VCO tuning. In the locked mode, the VCO is controlled by the phase detector and in unlocked mode, the frequency detector is superimposed. The VCO operates with an external resonance circuit (L and C parallel) and is controlled by internal varicaps. The VCO control voltage is also converted to a current and represents the AFC output signal at Pin 22. At the AFC switch (Pin 19) three operating conditions of the AFC are possible: AFC curve "rising" or "falling" and AFC "off". A practicable VCO alignment of the external coil is the adjustment to zero AFC output current at Pin 22. At center frequency the AFC output current is equal to zero. Furthermore, at Pin 14, the VCO center frequency can be switched for setting to the required L' value (L' standard). The optional potentiometer at Pin 26 allows an offset compensation of the VCO phase for improved sound quality (fine adjustment). Without a potentiometer (open circuit at Pin 26), this offset compensation is not active. The oscillator signal passes a phase shifter and supplies the in-phase signal ($\tilde{()}$) and the quadrature signal ($\tilde{()9}$) of the generated picture carrier.

5.3.5 VIDEO DEMODULATION AND AMPLIFIER

The video IF signal, which is applied from the gain controlled IF amplifier, is multiplied with the inphase component of the VCO signal. The video demodulator is designed for low distortion and large bandwidth. The demodulator output signal passes an integrated low pass filter for attenuation of the residual vision carrier and is fed to the video amplifier. The video amplifier is realised by an operational amplifier with internal feedback and 8 MHz bandwidth (−3 dB). A standard dependent dc level shift in this stage delivers the same sync. level for positive and negative modulation. An additional noise clipping is provided. The video signal is fed to VIF-AGC and to the video output buffer. This amplifier with a 6 dB gain offers easy adaptation of the sound trap. For nominal video IF modulation the video output signal at Pin 12 is 2 Vpp.

5.3.6 SOUND IF AMPLIFIER AND SIF-AGC

The SIF amplifier is nearly identical with the 3-stage VIF amplifier. Only the first amplifier stage exists twice and is switchable by a control voltage at Pin 3. Therefore with a minimal external expense it is possible to switch between two different SAW filters. Both SIF inputs features excellent cross-talk attenuation and an input impedance which is independent from the switching condition. The SIF-AGC is related to the average level of AM- or FM-carrier and controls the SIF amplifier to provide a constant SIF signal to the AM demodulator and QPS mixer.

5.3.7 QUASI-PARALLEL-SOUND (QPS) MIXER

The QPS mixer is realised by a multiplier. The SIF signal (FM or NICAM carrier) is converted to the intercarrier frequency by the regenerated picture carrier (quadrature signal) which is provided from the VCO. The intercarrier signal is fed via an output amplifier to Pin 24.

5.3.8 STANDARD SWITCH

To have equal polarity of the video output signal the polarity can be switched in the demodulation stage in accordance with the TV standard. Additionally a standard dependent dc level shift in the video amplifier delivers the same sync. level. In parallel to this, the correct VIF-AGC is selected for positive or negative modulated VIF signals. In the case of negative modulation (e.g., B/G standard) the AM output signal is switched off. For positive modulation (L standard) the AM demodulator and QPS mixer is active. This condition allows a parallel operation of the AM sound signal and the NICAM-L stereo sound.

5.3.9 L' SWITCH

With a control voltage at Pin 14 the VCO frequency can be switched for setting to the required L' value (L' standard). Also a fine adjustment of the L'-VCO center frequency is possible via a potentiometer. The L' switch is only active for positive modulated video IF-signals (standard switch in L mode).

5.3.10 INTERNAL VOLTAGE STABILISER

The internal bandgap reference ensures constant performance independent of supply voltage and temperature.

5.4 VIDEO / RGB

5.4.1 FRONT END

5.4.1.1 CVBS Front-End

The CVBS front-end consists of the colour-decoding circuit itself, a sync processing circuit for generation of H/V signals out of the CVBS signal, and the luminance processing. The main task of the luminance processing is to remove the colour carrier by means of a notch filter. For PAL

and SECAM operation a baseband delay line is used for U and V signals. This can be used as comb filter in NTSC operation (only for chrominance). The RGB input from SCART is used as an overlay for the CVBS channel (RGB+FBL).

This block contains a matrix (for RGB signals).

5.4.1.2 Input Selector

The analog CVBS or SVHS luma signal are fed to the inputs CVBS1...7 of VSP94x2A (amplitude 0.5...1.5 V pp). One signal is selected and fed to the first ADC. A second signal (SVHS Chroma) can be selected and fed to the other ADC. After clamping to the back porch both signals are AD-converted with an amplitude resolution of 9 bit. The AD conversion is done using a 20.25 MHz free-running stable crystal clock. Before the A to D conversion the signals are lowpass filtered to avoid antialias effects. One input is looped back to output CVBSO1(#63). A signal addition is performed to output a CVBS signal even when separate Y/C signals are used at input.

5.4.1.3 Signal Levels And Gain Control

To adjust to different CVBS input voltages a digitally working automatic gain control is implemented. Input voltages in the range between 0.6 to 1.8 V pp can be applied to the CVBS inputs.

5.4.1.4 Synchronization

After elimination of the high frequent components of the CVBS signal by a low pass filter, horizontal and vertical sync pulses are separated. Horizontal sync pulses are generated by a digital phase locked loop. The time constant is adjusted between fast and slow behaviour to accommodate different input sources (e.g. VCR).

5.4.1.5 Chroma Decoder

The digital multistandard chroma decoder is able to decode NTSC and PAL signals with a subcarrier frequency of 3.58 MHz and 4.43 MHz as well as SECAM signals with automatic standard detection. The TV controller software has configured the colour decoder to operate in automatic detection mode. When the signal source comes from the tuner, only SECAM and PAL (50Hz) standard are enabled. In AV mode or when program number 0 is selected the following standards are also enabled : NTSC M, NTSC 4.43 and PAL 60.

The demodulation is done with a regenerated colour-carrier.

5.4.1.6 Luminance Processing

A luminance notch filter is implemented to separate the chroma information from the luminance. Depending on the colour standard, one out of three different notch characteristics is chosen ('PAL', 'NTSC', 'SECAM') automatically.

5.4.1.7 RGB Front-End

An analogue RGB input port for an external RGB source is available. The incoming signal is clamped to the back porch by a clamping pulse. This input as an overlay input (soft mix). The RGB signal must then be synchronised to the main CVBS/YC signal.

5.4.1.8 Signal Processing

5.3.1.8.1 Horizontal Prescaler

The main application of the horizontal prescaler is the conversion of the number of pixels coming from the 40.5/20.25 MHz pixel clock domain down to the number of pixels stored in the memory (factor 2/3). Generally the number of incoming pixels can be decimated by a factor between 1 and 64 in a granularity of 2 output pixels. The horizontal scaler reduces the number of incoming

pixels by subsampling. To prevent the introduction of alias distortion low pass filters are used for luminance and chrominance processing. The horizontal prescaler consists of two main subsampling stages. The first stage is a scaler for rational decimation factors in a range of 1 to 2. The second stage decimates in integer steps (1,2,3,4...32).

5.3.1.8.2 Noise Reduction

The structure of the temporal motion adaptive noise reduction is the same for luminance as for chrominance signal.

The output of the motion detector is weighted. The look-up table input value range is separated into 8 segments. It is possible to freely program different behaviour of the noise reduction by using predefined curve characteristic for each segment.

5.3.1.8.3 Noise Measurement

The noise measurement algorithm is used to sort program during ATSS. This is done by the TV-microcontroller which reads the noise level in VSP. The value is determined by averaging over several fields.

5.3.1.8.4 Operation Modes

The interlaced input signal (e.g. 50 Hz PAL or 60 Hz NTSC) is composed of a field A (odd lines) and a field B (even lines). The 100Hz operation mode used is simply AABB, where each stored field in the memory is displayed double times on the TV screen.

A still field can be displayed using *FREEZE* command, the operation mode becomes ABAB.

5.3.1.8.5 Digital 656 Output

The output data format corresponds to CCIR 656 with double-scan format (8-bit bus at a data rate of 54 MHz). There all frequencies and data-rates are doubled compared to standard CCIR656 specification. Timing reference codes (SAV, EAV) are inserted according to the specification. The output is set to 720 pixels per line and the display clock is set to 54 MHz.

5.4.2 BACK END

5.4.2.1 Digital Input Interface

The digital input interface is set to receive 8 bit 4:2:2 Y Cr Cb multiplexed with separate H/V-syncs and clock (ITU-R-656 format). The data inputs Y0...Y7 and C0...C7 are clocked with the external clock LLC2. The clock frequency is 54 MHz for 8 bit data input. The horizontal sync pulse at the HS pin should be an active video signal, which is not vertically blanked. A clock generator converts the different external line locked clock rates to a common internal sample rate of approximately 40.5 MHz, in order to provide a fix bandwidth for all digital filters. Therefore the input data is sample rate converted to the common processing frequency by the horizontal scaler.

5.4.2.2 Horizontal Scaler

The horizontal scaler supports linear or nonlinear horizontal scaling of the digital input video signal in the range of 0.25 to 4. Nonlinear scaling, also called "panorama vision", provides a geometrical distortion of the input picture. It is used to fit a picture with 4:3 format on a 16:9 screen by stretching the picture geometry at the borders. Also, the inverse effect can be produced by the scaler. See also microcontroller section to find details on format switching logic.

5.4.2.3 Luma Contrast and Brightness

The luminance signal is multiplied by a factor of 0...2 (contrast adjustment). The signal can be shifted by $\pm 100\%$ of its maximal amplitude with the digital brightness value

5.4.2.4 Black Level Expander/Compressor (BLEC)

The black level expander/compressor modifies the luminance signal with an adjustable non-linear function to enhance the contrast of the picture.

Dark areas are stretched to black, while bright areas remain unchanged. Advantageously, this black level processing is performed dynamically and only if it will be most noticeable to the viewer.

5.4.2.5 Luma Sharpness Enhancer (LSE)

Sharpness is one of the most critical features for optimum picture quality. This important processing is performed in the LSE circuitry of DDP 3315C. It consists of the dynamic peaking, the luma transient improvement (LTI) and an adaptive mixer. The luma input signal is processed in the peaking and LTI block in parallel. Both output signals are combined in the mixer depending on the selected LSE characteristic.

5.4.2.6 Dynamic Peaking

The dynamic peaking improves the details of a picture by contour emphasis. It adapts to the amplitude and the frequency of the input signal. Small detail amplitudes are sharpened, while large detail amplitudes stay nearly unmodified.

5.4.2.7 Luma Transient Improvement (LTI)

For small detail amplitudes the dynamic peaking is the most appropriate processing to improve the sharpness. However, for large amplitudes even small over- and/ or undershoots of the peaking are too annoying. The luma transient improvement enhances the slope of picture detail without these effects by a non-linear processing. The contour correction signal calculated in this block, is limited to the adjacent extreme values to prevent over- and undershoots. The LTI features an adjustable gain control and an adjustable coring threshold to prevent the enhancement of small noise amplitudes.

5.4.2.8 Mixing of Dynamic Peaking and LTI

The contour correction signals of the dynamic peaking and the LTI block are combined by the mixer. Controlled by the amplitude of a picture edge, this circuitry fades between these two signals. Thus, small and medium picture detail is enhanced by contour emphasis (peaking) and large picture detail is enhanced by step-improvement (LTI).

5.4.2.9 Chroma Transient Improvement

The intention of this block is to enhance the chroma resolution. A correction signal is calculated by differentiation of the colour difference signals. The differentiation can be selected according to the signal bandwidth, e.g. for PAL/NTSC/SECAM or digital component signals, respectively. The amplitude of the correction signal is adjustable. Small noise amplitudes in the correction signal are suppressed by an adjustable coring circuit. To eliminate "wrong colours", which are caused

by over and undershoots at the chroma transition, the sharpened chroma signals are limited to a proper value automatically

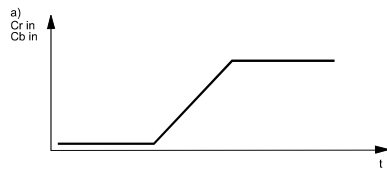

- a) Cr Cb input of CTI
- b) Cr Cb input + correction signal
- c) sharpened and limited Cr Cb

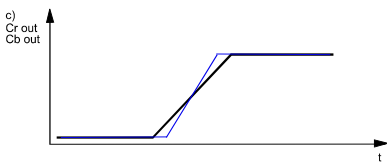
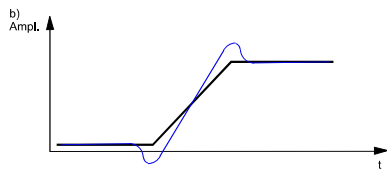

5.4.2.10 Analog Back End

The digital RGB signals are converted to analogue RGB by three 10-bit digital to analogue converters (DAC). Each RGB signal has two additional DACs with 9-bit resolution to adjust analogue brightness (40% of the full RGB range) and cutoff / black level (60% of the full RGB range). An additional fixed current is applied for the blanking level.

The back-end supports the insertion of two external analogue component signals, only one is used for OSD/Text from the microcontroller. These signals are clamped, processed in an analogue matrix (RGB2), converted by a voltage/current converter (VCC), and inserted into the main RGB by the fast blank switch. The analogue RGB outputs are current outputs with current-sink characteristics.

5.4.2.11 Analog RGB Insertion

Each component signal is clamped, converted to RGB if required, and inserted into the main RGB by the fast blank switch. The external component signals are adjustable independently as regards DC level (brightness) and magnitude (contrast).

Fast Blank selection logic Over-/underlay of the external component signal and the main RGB signal depends on the fast blank input signal.

5.4.2.12 CRT Measurement and Control

In order to define accurate colour on different CRT displays, the cut-off and white drive settings are adjusted in factory depending on the characteristic of CRT phosphor.

To guarantee correct colours during the lifetime of the display, a build in automatic tube control loop measures and adjusts the black level on every field and white point every third field. The display processor is equipped with an 9/12-bit PDM-ADC for all picture tube measuring purposes. This MADC is connected to the SENSE input pin, the input range is 0 to 2.6 V. Cutoff and white drive current measurement are carried out with 8-bit resolution during the vertical blanking interval. The current range for cutoff measurement is set by connecting the sense resistor RC591 to the SENSE input. Due to the fact of a 1:10 relation between cutoff and white drive current the range select 2 output (RSW2) becomes active for the white drive measurement and connects R533 in parallel to RC591, thus determining the correct current range.

During the active picture, the MADC is used for the average beam current limiter with a 12-bit resolution. Again a different measurement range is selected with active range select 1&2 outputs (RSW1&RSW2) connecting R534 in parallel to R533 and RC591.

These measurements are typically done at the summation point of the picture tube cathode currents.

The picture tube measurement returns results on every field for:

- cutoff R
- cutoff G
- cutoff B
- white drive R or G or B (sequentially)

The average beam current limiter (BCL) works on both the digital YC r C b input from VSP and the inserted analog RGB signals (OSD and Teletext) by using the sense input for the beam current measurement. The BCL uses a different filter to average the beam current during the active picture resulting in a 12-bit resolution. The filter bandwidth is approximately 4 kHz. The beam current limiter allows the setting of a threshold current, a gain and an additional time constant. To accommodate several CRT's, beam current threshold and gain can be modified by microcontroller option2. If the beam current is above the threshold, the excess current is low-

pass filtered with the according gain and time constant. The result is used to attenuate the RGB outputs by adjusting the white drive multipliers for the internal (digital) RGB signals, and the analog contrast multipliers for the analog RGB inputs, respectively. The lower limit of the attenuator is programmable, thus a minimum contrast can always be set. If the minimum contrast is reached, the brightness will be decreased to a programmable minimum as well.

5.4.2.13 Synchronization and Deflection

The deflection processing generates the signals for the horizontal and vertical drive. This block contains two numeric phase-locked loops and a security unit:

- PLL2 generates the horizontal and vertical timing, e.g. blanking, clamping and sync signals. Phase and frequency are synchronised by the incoming sync signals.
- PLL3 adjusts the phase of the horizontal drive pulse and compensates for the delay of the horizontal output stage.
- The security unit observes the H-Drive output signal.

With an external 5 MHz reference clock this unit controls the H-drive “off time” and period. In case of an incorrect H-drive signal the security unit generates a free running h-drive signal divided down from beam current

5.4.2.14 EHT Compensation

The vertical deflection waveform is scaled according the average beam current. This is used to compensate the effects of electric high tension changes due to beam current variations. EHT compensation for East/West deflection is done with an offset corresponding to the average beam current.

5.5 MICRONROLLER

5.5.1 MICROCONTROLLER FEATURES

- 8-bit 8051 instruction set compatible CPU
- 33.33-MHz internal clock (max.)
- 0.360 μ s (min.) instruction cycle
- Two 16-bit timers : schedule software tasks , and user clock
- Watchdog timer
- Capture compare timer for infrared remote control decoding
- Pulse width modulation unit (2 channels 14 bit, 6 channels 8 bit) : used to control AGC Take Over Point .
- ADC (4 channels, 8 bit) : AFT, AGC, Local keys, OCP.
- UART

5.5.2 ACQUISITION FEATURES

- Multistandard Digital Data Slicer
- Parallel Multi-norm Slicing (TTX, VPS, WSS)
- Four Different Framing Codes Available
- Data Caption only Limited by available Memory
- Programmable VBI-buffer
- Full Channel Data Slicing Supported
- Fully Digital Signal Processing
- Noise Measurement and Controlled Noise Compensation

- Attenuation Measurement and Compensation
- Group Delay Measurement and Compensation
- Exact Decoding of Echo Disturbed Signals

5.5.3 PORTS

- One 8-bit I/O-port with open drain output and optional I 2 C Bus emulation support (Port 0)
- Two 8-bit multifunction I/O-ports (Port 1, Port 3)
- One 4-bit port working as digital or analogue inputs for the ADC (Port 2)
- One 2-bit I/O-port with secondary functions (P4.2, 4.3, 4.7)

5.5.4 μ -CONTROLLER I/O PIN CONFIGURATION AND FUNCTION TABLE

PIN	NAME	CONFIGURATION		DESCRIPTION															
		STAND BY	TV ON																
3	S/SW2	Open Drain	Open Drain	<table border="1"> <thead> <tr> <th>#4</th> <th>#3</th> <th>Source</th> </tr> </thead> <tbody> <tr> <td>L</td> <td>L</td> <td>Tuner</td> </tr> <tr> <td>L</td> <td>H</td> <td>AV2-16/9</td> </tr> <tr> <td>H</td> <td>L</td> <td>AV2-4/3</td> </tr> <tr> <td>H</td> <td>H</td> <td>AV2-4/3</td> </tr> </tbody> </table>	#4	#3	Source	L	L	Tuner	L	H	AV2-16/9	H	L	AV2-4/3	H	H	AV2-4/3
#4	#3	Source																	
L	L	Tuner																	
L	H	AV2-16/9																	
H	L	AV2-4/3																	
H	H	AV2-4/3																	
4	S/SW2	Open Drain	Open Drain																
5	OCP	Open Drain	Open Drain	Over Current Protection															
8	RESET out	Low	Open Drain	Reset video IC's															
15	S/SW1	High impedance	High impedance	ADC input															
16	AGC in	High impedance	High impedance	AGC input – ADC input															
17	KEY	High impedance	High impedance	Keyboard input – ADC input															
18	AFT	High impedance	High impedance	AFT input– ADC input															
21	Mod SW	High impedance	Push Pull	High = Negative modulation, Low = Positive modulation (L/L').															
22	SECAM L'	High impedance	Push Pull	Low = L, High =L'															
23	IR	High impedance	High impedance	Infrared Interrupt input															
24	SOUND INT	Input	input	Sound interrupt input – edge triggered															
47	Sound Mute	Push Pull - Low	Push Pull - High	Low=Mute															
48	AGC out	--	PWM out	Control tuner AGC (TOP)															
50	Relay	Push Pull - Low	Push Pull - High																
51	LED	Push Pull	Push Pull	Low : LED Red High : LED Green															
52	Power	Push Pull - Low	Push Pull - High	SMPS operation mode High=ON, Low=ST-BY															

5.5.5 TUNING

The AFC information is supplied by the demodulator IC, and becomes available on SDA55xx pin 15 for controlling software. The controlling software uses this information for tuner frequency tracking (automatic following). The AFC windows is typically between 50 KHz and 100 KHz. The minimum frequency step of the tuner is 50 Khz.

This AFC function is disabled when a program is tuned using the direct frequency entry or after fine tuning adjustment. Therefore it is recommended to tune channel with the TV search function (manual or ATSS) or using the direct channel entry to enable the Automatic Frequency Control.

5.5.6 AUTOMATIC PICTURE FORMAT SWITCHING

When AUTO mode is selected by the user, the television will automatically select the picture format for the user. If the user does not want to accept this selected format, he can always override the setting by use of the ZOOM control on the remote control.

The received information used for automatic picture format control (only while AUTO is selected) is supplied from two sources;

- By WSS data (Wide Screen Signalling Information : see the WSS European Telecommunication Standard ETS 300 294).
- The voltage level from SCART 1 or SCART 2, pin 8 (slow switching)

5.5.6.1 WSS Data

This digital signal is received at the beginning of line 23 in each frame. It is not a teletext signal, but the controller uses the same decoder resources to receive and decode the digital signal. This is bi-phase encoded using a clock frequency of 5 MHz. In total, 14 data bits are available, in 4 groups.

- Group 1 : Aspect Ratio (b0, b1, b2, b3)
- Group 2 : Enhanced Services (b4, b5, b6, b7)
- Group 3 : Subtitles (b8, b9, b10)
- Group 4 : Reserved (b11, b12, b13)

The signal contains bits in Data Group 1 which define an Aspect Ratio label, and in Data Group 3 (b10) which defines if subtitles are available in the video. The other data groups have no application in this TV for picture format selection.

The TV decoder recognises 5 bits of data (where b3 is an odd parity bit for Data Group 1).

Position	Aspect Ratio label	WSS Bits					Format Name	
		0	1	2	3	10	Tube 16:9	Tube 4:3
N/A	FORMAT_4_3	0	0	0	1	0	4:3	FULL SCREEN
CENTRE	FORMAT_14_9	1	0	0	0	0	ZOOM 14:9	FULL SCREEN
TOP	FORMAT_14_9	0	1	0	0	0	DEFAULT	DEFAULT
CENTRE	FORMAT_16_9	1	1	0	1	0	ZOOM 16:9	FULL SCREEN
TOP	FORMAT_16_9	0	0	1	0	0	FULL SCREEN	FULL SCREEN
CENTRE	FORMAT_16_9_PLUS	1	0	1	1	0	ZOOM 16:9	FULL SCREEN
CENTRE	FORMAT_14_9_FULL	0	1	1	1	0	FULL SCREEN	14:9
N/A	FORMAT_16_9_ANAM	1	1	1	0	0	FULL SCREEN	16:9
N/A	SUBTITLE_OUT_IMAGE	X	X	X	X	1	FULL SCREEN	FULL SCREEN

There are the following output possibilities;

- 4:3
- 14:9
- 16:9
- ZOOM 14:9
- ZOOM 16:9
- FULL SCREEN (for either 4:3 or 16:9 tubes)

DEFAULT refers to a signal for which there is no implementation, so is treated as if there is no signal data available.

5.5.6.2 SCART Pin 8 Data (Slow Switching)

When there is a signal from SCART 1 pin 8 or SCART 2 pin 8 (named the Slow Switching SSW signal) the TV will enter AV mode, unless the user forces another source (which is possible even though slow switching is present).

Position	Aspect Ratio	Switching Voltage Level	Format Name	
			Tube 16:9	Tube 4:3
CENTRE	4:3	HIGH	4:3	FULL SCREEN
CENTRE	16:9	MEDIUM	FULL SCREEN	16:9

The SCART 1 signal SSW1 has priority over SSW2.

5.5.6.3 Picture Format Description

From the information collected from the above sources is the input, from which the TV must decide which format to select. The WSS data always has priority over Slow Switching.

If no valid data is received from either source, then a default value must be assumed (this is controlled also by the user by the use of "ZOOM AUTO" in the "FEATURES" menu).

5.3.1.8.1 16:9 CRT

Formats available with 16:9 cathode ray tube;

- 4:3 (AUTO selectable)
- 14:9 (AUTO selectable)
- ZOOM 14:9 (AUTO selectable)
- ZOOM 16:9 (AUTO selectable)
- FULL SCREEN (AUTO selectable)
- PANORAMA (only available/selectable by the user)
- FAVOURITE (only available/selectable by the user)

The table below gives a summary of the FORMAT modes available with a 16:9 CRT, and their given properties.

Format Name	Zoom factor – 16:9 CRT		Description	Application
	Vertical	Horizontal		
4:3	100%	75%	Picture is centred with black bars at the left and right hand side of the display	Standard 4/3 picture with 576 active lines
14:9	114%	87%	Picture is centred with black bars at the left and right hand side of the display	14:9 picture – letter box format with 504 active lines
ZOOM 14:9	114%	100%	Picture is displayed filling the full width of the screen by incorporating a small horizontal geometrical error (typically 8% linear)	14:9 picture – letter box format with 504 active lines
ZOOM 16:9	133%	100%	Picture is displayed filling the full screen (width and height)	16:9 picture – letter box format with 430 active lines

FULL SCREEN	100%	100%	Picture is displayed filling the full screen (width and height)	Standard 16/9 picture with 576 active lines
PANORAMA (not AUTO)	100%	100%	Picture is displayed filling the full screen (width and height) by incorporating a non-linear horizontal geometrical error	Used to fit a picture with 4:3 format on a 16:9 screen by stretching the picture geometry at the borders
FAVOURITE (not AUTO)	100% to 133%	75% to 100%	Customised picture size	User-definable format.

5.3.1.8.2 4:3 CRT

Formats available with 16:9 cathode ray tube;

- 14:9 (AUTO selectable)
- 16:9 (AUTO selectable)
- FULL SCREEN (AUTO selectable)
- WATERGLASS (only available/selectable by the user)
- FAVOURITE (only available/selectable by the user)

The table below gives a summary of the FORMAT modes available with a 4:3 CRT, and their given properties.

Format Name	Zoom factor – 4:3 CRT		Description	Application
	Vertical	Horizontal		
14:9	87%	100%	Picture is centred with black bars at the top and bottom of the display, realised by compressing the vertical size	14:9 picture – letter box format with 576 active lines
16:9	75%	100%	Picture is centred with black bars at the top and bottom of the display, realised by compressing the vertical size	16:9 picture – letter box format with 576 active lines
FULL SCREEN	100%	100%	Picture is displayed filling the full screen (width and height)	Standard 4:3 picture with 576 active lines
WATERGLASS (not AUTO)	100%	100%	Picture is displayed filling the full screen (width and height) by incorporating a non-linear horizontal geometrical error	Used to fit a picture with 16:9 format on a 4:3 screen by compressing the picture geometry at the borders
FAVOURITE (not AUTO)	100% to 133%	75% to 100%	Customised picture size	User-definable format.

5.5.7 EXTERNAL SOURCE CONTROL LOGIC

The following schematic, illustrates the logic of control for the two SCART connectors.

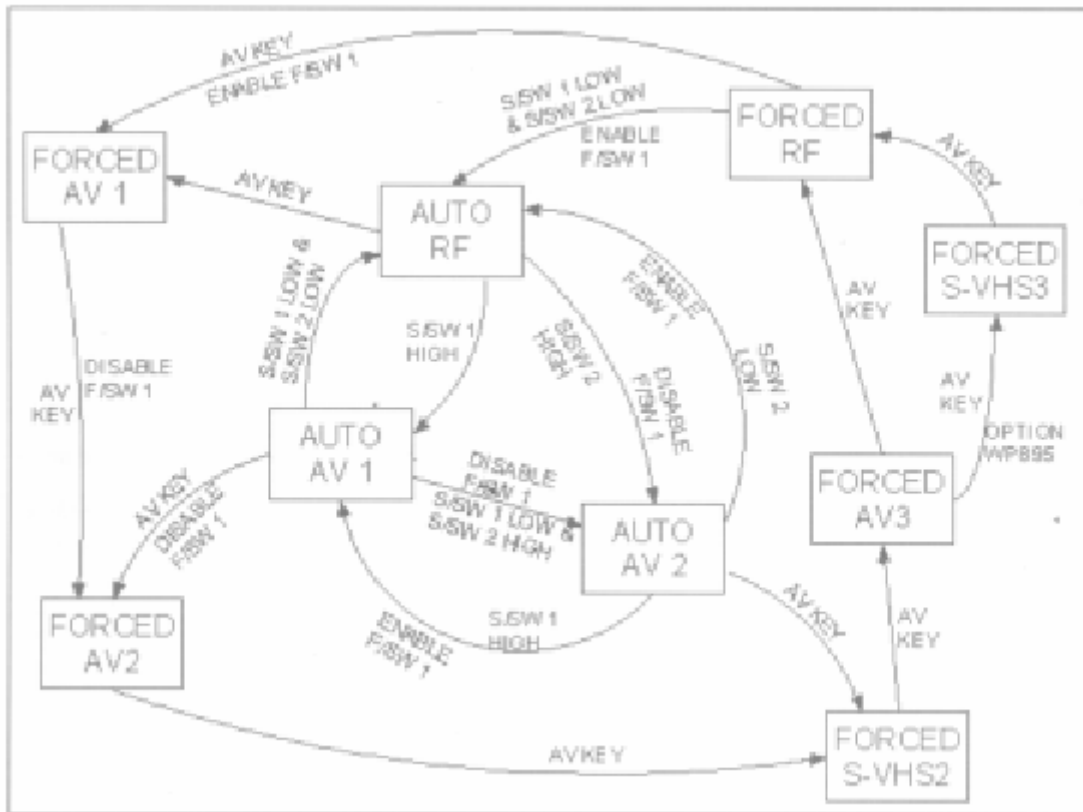

The terms used in the schematic are described below;

1. AUTO represents a situation where the television has self-selected its picture source. This could be when the SCART SLOW SWITCHING pin has gone to a high state, and the AV 1 input is selected without the intervention of the user.
2. FORCED represents the change of source which has been commanded by the user (using the EXTERNAL button). The user always has priority, and can override the AUTO change of source by the television.
3. AV KEY represents the EXTERNAL button of the remote control, or on the television.
4. S/SW 1, or S/SW 2 represent the SLOW SWITCHING inputs of the first SCART (AV 1) or second SCART (AV 2), these each being pin number 8.
5. F/SW 1 represents the FAST SWITCHING input of the first SCART (AV 1), on pin number 16. The second SCART, AV 2, input does not possess a FAST SWITCHING input.

The HIGH state of a slow switching input represents the request from the external source to be selected by the television. Whether this is accepted or not depends on the position in the logic diagram. The general rule is that the user always has priority, so the use of the AV KEY will always result in a defined logic path being followed.

Under certain circumstances, defined in the diagram, the change of state of a slow switching input will result in the automatic change of source by the television. This change, such as the change from RF broadcast to the AV 1 input, can always be overridden by the user after the event.

Each line on the diagram, with its associated text, represents the exact conditions under which the change of state will occur. Sometimes this will be accompanied by another action which will be automatically performed by the television, being to either ENABLE or DISABLE F/SW 1.

5.5.8 OVER CURRENT PROTECTION

In case of overload, the SMPS secondary voltages will drop. The voltage on pin 5 of microcontroller changes Low to High. The controlling software which continuously monitors this voltage will switch the set to stand by mode. To power on the set again the user must switch it off using the main power switch. Appropriate hysteresis guaranty a reliable operation.

5.6 TELETEXT DISPLAY

National character option bits C12, C13, C14 are transmitted in the page header of a given teletext page. The national option bits are intended to change (or exchange) 13 characters within the G0 character set, according to the needs of each national language.

These codes represent, for a given broadcaster, the intended language that the teletext page should be displayed in. As there are only 3 bits, there are only 8 codes available to cover all the possible language combinations. This means that for a received code there are several possibilities meanings, according to the local code of practice.

This is not as bad as it first seems, as we use the user-selected OSD language to identify the intention of the broadcaster. For example, a user wishing to see Russian teletext should select Russian OSD language, otherwise he would not have correct teletext display on the TV. The table below allows the reader to understand the relationship between selected OSD language (which is under user control), the teletext language display (selected by national option bits in transmission page header) and the Packet 26 language selection (selected within packet 26 of the transmission page).

An example: For Greek teletext display, (if national option code 1 1 1 is received from the broadcaster), the user should select the Greek OSD language. Even if English, French, German, Italian, Spanish, Dutch, Danish, Finnish, Norwegian or Swedish OSD languages are selected, the teletext will be correctly displayed.

However, if Polish, Hungarian, Czech, Slovakian, Rumanian or Russian OSD are selected, the consequence will be incorrect teletext display for the national option characters. Romanian national font options will be selected.

OSD Language	C12	C13	C14	PRIMARY LANGUAGE	Secondary Language	X26 Language
English, French, German, Italian, Spanish, Dutch, Danish, Finnish, Norwegian, Swedish, Greek	0	0	0	English	English	West Euro
	0	0	1	German	German	West Euro
	0	1	0	Scandinavian	Scandinavian	West Euro
	0	1	1	Italian	Italian	West Euro
	1	0	0	French	French	West Euro
	1	0	1	Spanish	Spanish	West Euro
	1	1	0	Turkish	Turkish	West Euro
	1	1	1	Greek	English	Greek
Polish, Hungarian, Czech, Slovakian, Rumanian	0	0	0	Polish	Polish	East Euro
	0	0	1	German	German	West Euro
	0	1	0	Hungarian	Hungarian	East Euro
	0	1	1	Italian	Italian	West Euro
	1	0	0	French	French	West Euro
	1	0	1	Serbian	Serbian	East Euro
	1	1	0	Czech	Czech	East Euro
	1	1	1	Rumanian	Rumanian	East Euro
Bulgarian, Russian	0	0	0	English	Russian	Cyrillic
	0	0	1	German	German	West Euro
	0	1	0	Estonian	Estonian	East Euro
	0	1	1	Lettish	Lettish	East Euro
	1	0	0	Russian	English	Cyrillic
	1	0	1	Ukrainian	English	Cyrillic
	1	1	0	Czech	Czech	East Euro
	1	1	1	Rumanian	Rumanian	Cyrillic

5.7 SOUND PROCESSING

5.7.1 ANALOGUE SOUND IF - INPUT SECTION

The input pins ANA_IN1+ and ANA_IN- offer the possibility to connect sound IF sources to the MSP 341xG. The analogue-to-digital conversion of the preselected sound IF signal is done by an A/D converter, whose output is used to control an analogue automatic gain circuit (AGC), providing an optimal level for a wide range of input levels.

5.7.2 QUADRATURE MIXERS

The digital input coming from the integrated A/D converter may contain audio information at a frequency range of theoretically 0 to 9 MHz corresponding to the selected standards. By means of two programmable quadrature mixers, two different audio sources ; for example, NICAM and FM-mono, may be shifted into baseband position.

5.7.3 PHASE AND AM DISCRIMINATION

The filtered sound IF signals are demodulated by means of the phase and amplitude discriminator block. On the output, the phase and amplitude is available for further processing. AM signals are derived from the amplitude information, whereas the phase information serves for FM and NICAM demodulation.

5.7.4 NICAM DECODER

In case of NICAM - mode, the phase samples are decoded according the DQPSK - coding scheme. The output of this block contains the original NICAM bitstream.

5.7.5 DSP SECTION

All audio baseband functions are performed by digital signal processing (DSP). The DSP section controls the source and output selection, and the signals processing.

5.7.6 SOUND MODE SWITCHING

In case of NICAM transmission, the controlling software read the bit error rate and the operation mode from the NICAM Decoder. When the set is in "Auto detection" mode (default mode after ATSS) the MSP firmware set automatically the sound mode (NICAM mono, NICAM Dual 1 or NICAM Dual 2) depending on the transmitted mode.

In case of 2 Carrier FM transmission, the MSP firmware read the transmission mode and the signal quality level from the Stereo Detection Register. When the set is in "Auto detection" mode the firmware set automatically the sound mode (mono, Stereo, Dual 1, Dual 2) depending on the transmitted mode.

In "Auto detection" mode the firmware evaluate the signal quality and automatically switch to the analogy sound carrier 1, if the transmission quality is too poor. To avoid unwanted automatic switching the threshold levels mono to stereo and stereo to mono is different.

When the sound mode change, the MSP firmware informs the microcontroller by rising pin 4. This generates an interrupt to the controller, which then read MSP registers via I2C bus to know the new sound status, and update OSD when needed.

In "forced mono " mode (locker icon), the controlling software configure the MSP341xG to demodulate only the analogue (FM or AM) sound carrier 1, no matter the signal quality. The sound mode " forced " or " Autodetect" is stored for each programme.

5.8 SOUND AMPLIFICATION

The TDA8946J is a stereo BTL audio amplifier capable of delivering 2 x 15 W output power to an 8 Ω load at THD = 10%, using a 18 V power supply and an external heatsink. The voltage gain is fixed at 32dB.

With the three-level MODE input the device can be switched from 'standby' to 'mute' and to 'operating' mode.

The TDA 8946J outputs are protected by an internal thermal shutdown protection mechanism and short-circuit protection.

5.8.1 POWER AMPLIFIER

The power amplifier is a Bridge Tied Load (BTL) amplifier with an all-NPN output stage, capable of delivering a peak output current of 1.5 A.

The BTL principle offers the following advantages :

- Lower peak value of the supply current.
- The ripple frequency on the supply voltage is twice the signal frequency.
- No DC-blocking capacitor
- Good low frequency performance

5.8.2 MODE SELECTION

The TDA8946J has several functional modes, which can be selected by applying the proper DC voltage to pin MODE.

Mute : In this mode the amplifier is DC biased but not operational (no audio output). This allows the input coupling capacitors to be charged to avoid pop-noise. The device is in mute mode when $2.5\text{ V} < V_{\text{MODE}} < (V_{\text{CC}} - 1.5\text{ V})$.

Operating : In this mode the amplifier is operating normally. The operating mode is activated at $V_{\text{MODE}} < 0.5\text{ V}$.

5.9 VERTICAL DEFLECTION

The vertical driver circuit is a bridge configuration. The deflection coil is connected between the output amplifiers, which are driven in phase opposition. The differential input circuit is voltage driven. The input circuit is especially intended for direct connection to driver circuits which deliver symmetrical current signals, but is also suitable for asymmetrical currents. The output current of these devices is converted to voltages at the input pins via resistors R350 and R351. The differential input voltage is compared with the output current through the deflection coils measured as voltage across R302, which provides internal feedback information. The voltage across R302 is proportional to the output current.

5.9.1 FLYBACK VOLTAGE

The flyback voltage is determined by an additional supply voltage V_{flb} . The principle of operation with two supply voltages (class G) makes it possible to fix the supply voltage V_p optimum for the scan voltage and the second supply voltage V_{flb} optimum for the flyback voltage. Using this method, very high efficiency is achieved. The supply voltage V_{flb} is almost totally available as flyback voltage across the coil, this being possible due to the absence of a coupling capacitor.

5.9.2 PROTECTION

The output circuit has protection circuits for :

- Too high die temperature
- overvoltage of output stage A

5.9.3 GUARD CIRCUIT

The guard signal is not used by the video IC to blank the screen in case of fault condition.

5.9.4 DAMPING RESISTOR

For HF loop stability a damping resistor (R331 & R332) is connected across the deflection coil.

5.9.5 EAST-WEST AMPLIFIER

The East-West amplifier is current driven. It can only sink currents of the diode modulator circuit. A feedback resistor R397 is connected between the input and output of this inverting amplifier in order to convert the East-West correction input into an output voltage.

5.10 POWER SUPPLY (STR-W6754) - Functions of Each Terminal

5.10.1 Vcc Terminal (Pin 4)

5.10.1.1 Start-up Circuit

The start-up circuit detects Vcc terminal (No.4 pin) voltage, and makes a control IC start and stop. The power supply of the control IC (Vcc terminal input) employs a circuit as shown in Fig.1. At start-up, C3 is charged through a start-up resistor R2. The R2 value needs to be set more than the holding current of the latch circuit (150 μ A Max), which is described later, to be flown at the minimum AC input.

However, where the R2 value is too high, the current charging to C3 shall be reduced after AC input. Consequently, it takes much time to reach the operation start-up voltage, so it is required to monitor the capacity of C3 that is mentioned later simultaneously. The Vcc terminal voltage falls immediately after the control circuit starts its operation; however the voltage drop is reduced by the increase of the C3 capacity. Therefore, even if the auxiliary drive winding voltage is delayed in rising, the Vcc terminal voltage does not fall up to the operation stop voltage to maintain the start-up operation. However, with larger capacity of C3, it takes much time, after AC input, to reach the operation start since the certain time is required to charge C3. In general, SMPS performs its operation properly with the value, C3 is 10 to 47 μ F, R2 is 47k to 150k Ohm for 100V wide input, and 82K to 330K Ohm for 200V narrow input for its start up.

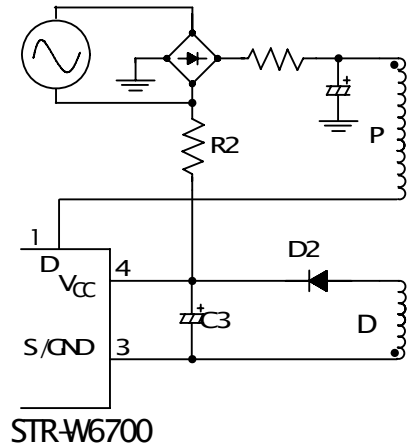

Fig.1. Start-up Circuit

As shown in Fig.2, the circuit current which makes the control circuit start is regulated at 100 μ A MAX (Vcc = 15V, Ta = 25C), and higher value resistor R2 is applicable to the circuit. Once the Vcc terminal voltage reaches 18.2V (TYP), the control circuit starts its operation by the Start-up Circuit, and current consumption shall be increased. Once the Vcc terminal voltage falls and it becomes lower than the operation stop voltage 9.6V (TYP) with the decrease of the Vcc terminal voltage, Under Voltage Lock Out (UVLO) circuit stops the controlling operation and returns to the start-up mode.

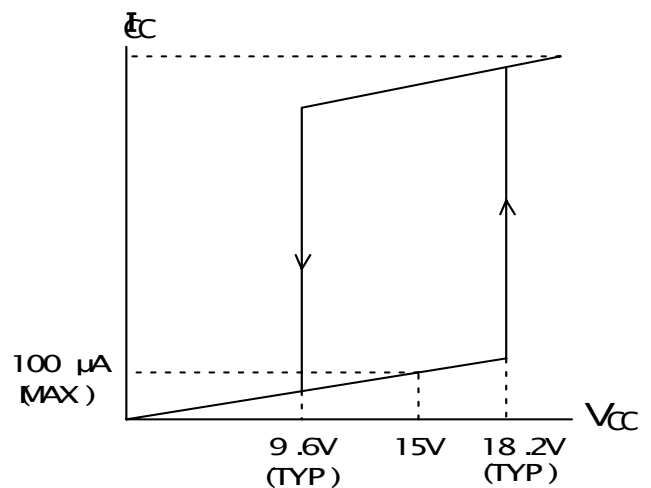

Fig.2. Vcc Terminal Vol. – Circuit Cur. Icc

5.10.1.2 Auxiliary/Drive Winding

After the control circuit starts its operation, the power supply is gained by rectifying and smoothing the voltage of the auxiliary winding D.

Fig.3 shows the start-up voltage waveform of the Vcc Terminal. The auxiliary winding voltage does not rise up to the set voltage after the control circuit starts its operation, and the Vcc terminal voltage starts falling. However, because the operation stop voltage is set as low as 10.6V(Max), the auxiliary winding voltage D reaches stabilizing voltage before falling to the operation

stop voltage, and the control circuit continues its operation.

The auxiliary winding voltage, at the normal power supply operation, is to be set the number of windings for both the ends voltage of C3 to be higher than the operation stop voltage [Vcc(OFF) 10.6V(MAX)] and lower than the OVP operation voltage [Vcc(OVP) 25.5V(MIN)].

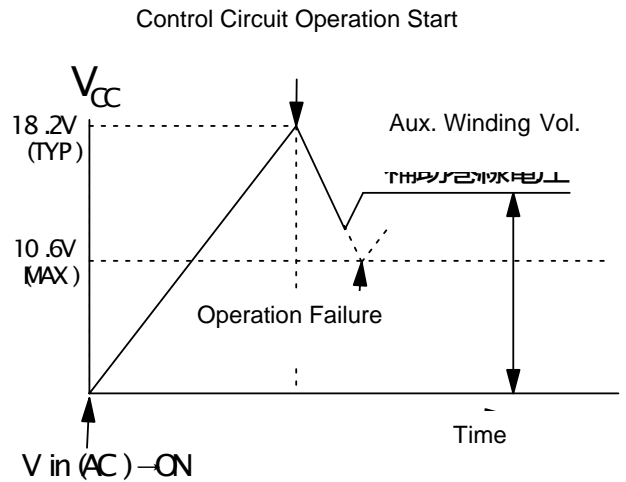

Fig.3. Waveform of Vcc Terminal Vol. at Start-up

Besides, in an actual power supply circuit, the Vcc terminal voltage might be varied by the value of secondary output current as shown in Fig.4. This is caused by the small circuit current of STR-W6700 itself and C3 is charged up to the peak value by the surge voltage generated instantly after the MOSFET is turned OFF.

In order to prevent this, it is effective to add a resistor having several to several tens ohms (R7) in series to a rectifier diode as shown in Fig.5. The optimum value of the additional resistor should be determined in accordance with the specs of a transformer since the Vcc terminal voltage is varied by the structure difference of transformers. Furthermore, the variation ratio of the Vcc terminal voltage becomes worse due to an inaccurate coupling between primary and secondary windings of the transformer (the coupling between the auxiliary winding D and the stabilizing output winding for the constant voltage control). Thus, for designing the transformer, the winding position of the auxiliary winding D needs to be studied carefully.

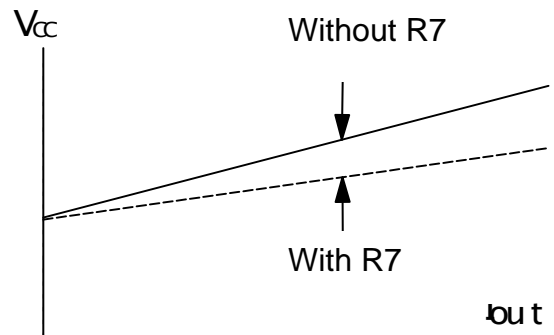

Fig.4. Output Current Iout – Vcc Terminal Vol.

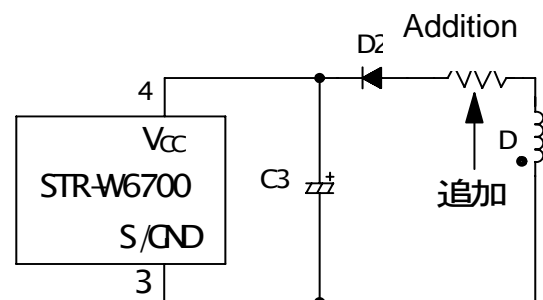

Fig.5. Auxiliary Power Supply Circuit not affected by Output Current Iout

5.10.1.3 Overvoltage Protection Circuit

Where the voltage exceeding 27.5V(TYP) is imposed on between Vcc and GND terminals, the OVP circuit of the control IC starts its operation and turns latch-mode, and the control IC stops its oscillation. Generally, the Vcc terminal voltage is supplied from the auxiliary winding of the transformer, and the voltage is in proportion to the output voltage; thus, the circuit also operates at that time when the overvoltage output of the secondary side comes out such as the voltage detection circuit open.

The secondary output voltage at the Overvoltage Protection circuit operation is obtained from the following formula:

$$V_{OUT} (OVP) \cong \frac{V_{OUT} \text{ at Normal Operation}}{V_{cc} \text{ Terminal Voltage at Normal Operation}} \times 27.5V (TYP) \dots\dots (1)$$

5.10.1.4 Latch Circuit

The latch circuit is a circuit that holds the oscillator output low and stops the power supply circuit operation when OVP or OLP circuit operates. The holding current of the latch circuit is 150 μ A MAX (Ta = 25C) when the Vcc terminal voltage is minus 0.3V to the operation stop.

In order to avoid improper operations caused by noises, etc., the delay-time is provided with a timer circuit incorporated in the HIC, and thereafter, the latch circuit starts its operation when OVP or OLP circuit operates for more than the set time. While, the Vcc terminal voltage drops even after the latch circuit starts its operation because the constant voltage (Reg) circuit of the control circuit continues its operation with higher circuit current.

Where the Vcc terminal voltage falls lower than the operation stop voltage (9.6V(TYP)), the voltage starts rising as the circuit current becomes lower than 150 μ A (Ta = 25C). Where the Vcc terminal voltage reaches the operation start voltage (18.2V(TYP)), it falls as the circuit current is increased again. Consequently, the latch circuit prevents the Vcc terminal voltage from rising abnormally by controlling the voltage between 9.6V (TYP) and 18.2V(TYP). The Fig.6 indicates the voltage waveform when the latch circuit is under operation. The latch circuit operation is cancelled by reducing the Vcc terminal voltage below 7.3V (TYP), and generally, it is restarted by AC input switch-off of the power supply.

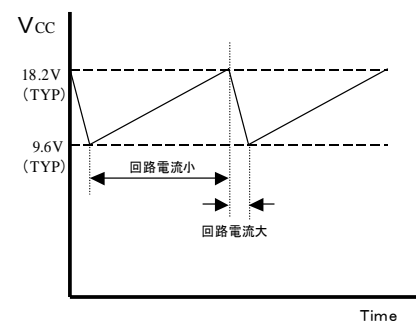

Fig.6. VCC Terminal Vol. Waveform at Latch-mode

5.10.2 SS/OLP Terminal (Pin 5)

The operation of SS/OLP terminal is classified as Soft-Start and Overload Protection, and the SS/OLP terminal is generally connected to a condenser having the value of 0.47 μ F to 3.3 μ F.

5.10.2.1 Soft-Start Operation at Start-up of Power Supply

At the power supply start-up, an external condenser is charged up to the threshold operating charging voltage (VSSOLP(SS)) by the Soft-Start operating charging current (ISSOLP(SS)) flowing from SS/OLP. The Soft-Start is provided at power supply start-up by utilizing the changing of SS/OLP terminal voltage from 0V to 1.0V. The timing chart of the Soft-Start is shown in Fig.7. Comparing the oscillation waveforms between OLP terminal voltage and the oscillation waveform of the internal control part, the Soft-Start widens the ON width. Besides, at the burst stand-by, the Soft-Start is operated every time; so, the magnetostriction noises from transformers are controlled with the increase of the drain current gradually.

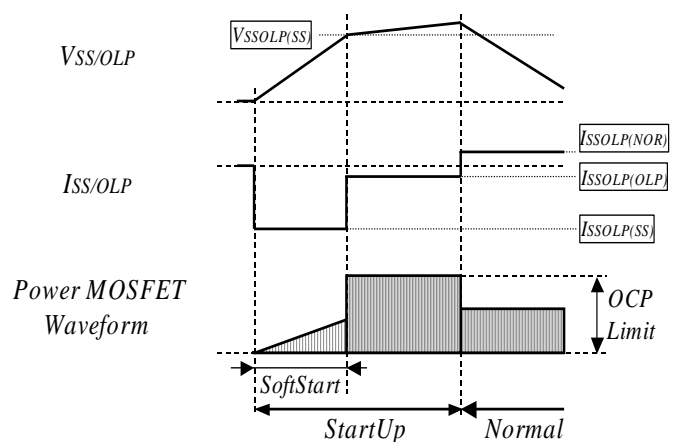

Fig.7. Soft-Start Operation

5.10.2.2 Overload Protection

The output characteristics of the secondary side at the time when the OCP circuit operates, due to the overload of the secondary side output, is shown in Fig.8. Where the output voltage falls below the overload mode, the auxiliary winding voltage of the primary side also falls proportionally, and the Vcc terminal voltage falls below shutdown voltage to stop the operation. In that case, as the circuit current is also decreased simultaneously, the Vcc terminal voltage rise again by the start-up resistor R_s's charging current, and the circuit re-operates intermittently at the operation start-up voltage. However, where the transformer has lots of output windings and the coupling is not sufficient, and even if the output voltage is reduced in overload mode, the operation may not be intermittent because the primary side auxiliary winding voltage does not fall. Although the intermittent operation is not provided, the operation itself can be protected by the OLP circuit.

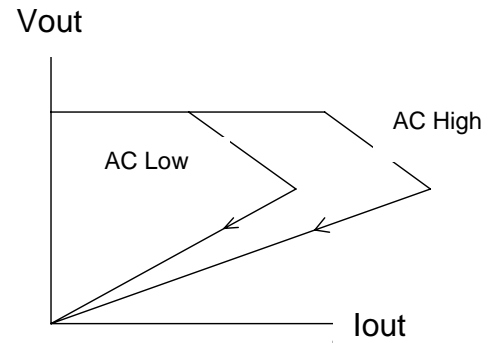

Fig.8. SMPS Output Overload Characteristics

In the overload mode (the mode in which the drain current is controlled by OCP operation), the secondary side output voltage falls. Thus, the error-amplifier and photo-coupler in secondary side need to be cut off. The STR-W6700 series recognizes the circumstances continuing OCP operation without FB signal as overload mode, and the SS/OLP terminal voltage starts rising by I_{SSOLP(OLP)} as shown in Fig.9, and after the SS/OLP terminal voltage continues rising to reach V_{SSOLP(OLP)} TYP 5V, the oscillation is stopped and turns the latch protection operation.

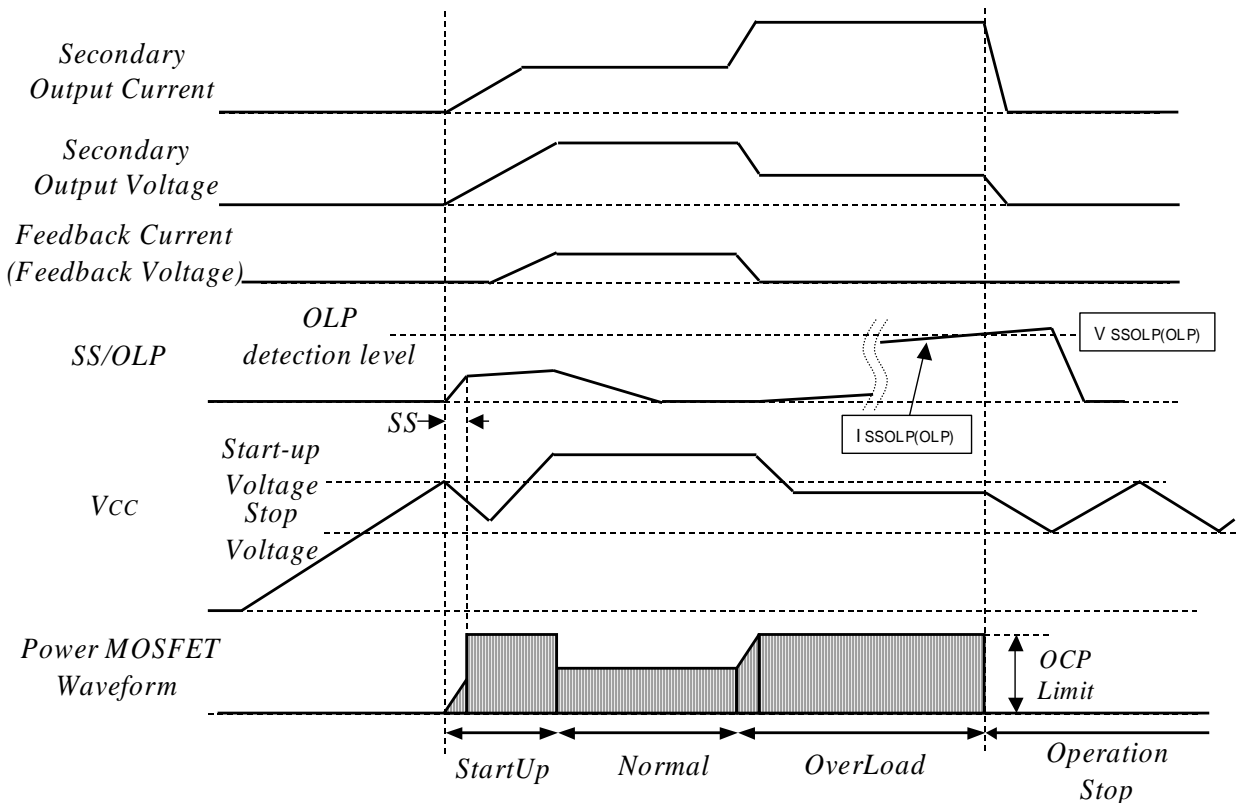

Fig.9. Timing-Chart at Overload

The time until the latch protection operation starts its operation can be calculated from the following formula since the ISSOLP(OLP) is a constant current circuit. That is,

$$C \text{ (Condenser Capacity)} \times \Delta V \text{ (Condenser Charging Voltage: approx. 5V)} = I_{SSOLP(OLP)} \times t \text{ (time)} \dots\dots (2)$$

While, the ISSOLP(OLP) contains the voltage dependent characteristics on SS/OLP terminal voltage, and ISSOLP(OLP) falls when SS/OLP terminal voltage rises. The actual value does not match to the value calculated from the formula (2) completely, so it is recommended to monitor the actual load conditions. Furthermore, the power supply start-up voltage turning OCP operation is also needed to confirm.

5.10.2.3 Operation at Power Supply OFF

The voltage of the condenser mounted externally to SS/OLP terminal is discharged by the internal reset circuit of the HIC at power OFF. The reset circuit does not start its operation at normal operation (i.e., while the internal constant voltage circuit operates).

5.10.2.4 Cancellation of OLP Circuit

The OLP operation is cancelled by inserting a resistor having 47K ohms (or Zener diodes) into SS/OLP terminal at start-up or overload maintaining Soft-Start operation effectively.

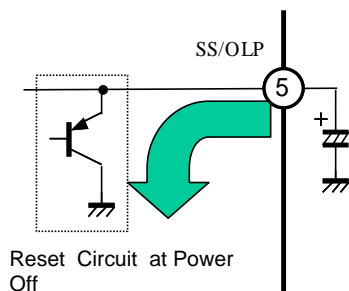

Fig.10. Reset Circuit

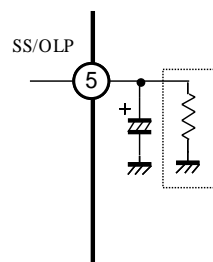

Fig.11. OLP Cancellation Circuit

5.10.3 FB Terminal (Pin. 6)

The operation of FB terminal is divided into normal (constant voltage control circuit operation) and stand-by operation control. Refer to item No. 8.6 for the controlling at stand-by operation.

5.10.3.1 Constant Voltage Control Circuit

The STR-W6700 series adopts the current mode controlling circuit for the constant voltage control, which proves its superiority in a heavy load. The MOSFET drain current peak value (\hat{I}_D ON time) is varied comparing FB terminal voltage and HIC's internal VOCPM. During the OFF-time, Quasi-Resonant operation synchronized to the reset signal from a transformer is applied. While, where no reset signal is supplied from the transformer, the fixed oscillation frequency (approx. 22kHz) is applied by the HIC's internal oscillation circuit. The timing chart is shown in Fig.12, and the internal circuit diagram at the constant voltage control is shown in Fig. 13. respectively.

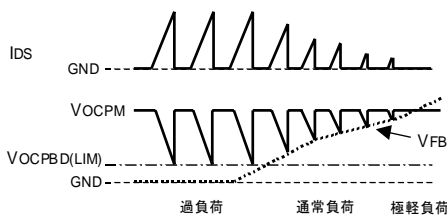

Fig.12. Constant Control Voltage

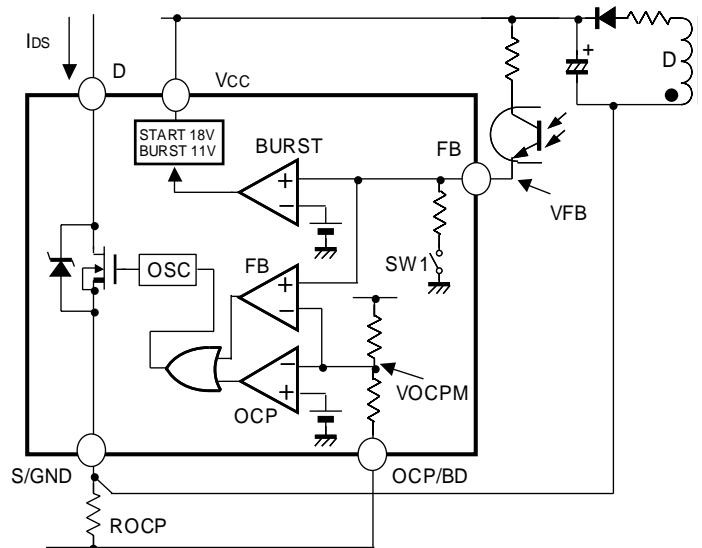

Fig.13. Constant Voltage Control Circuit (Theory)

The constant voltage controlling circuit makes the control signal (FB current) flowing from the secondary side error-amplifier input to No.6 terminal by the photo-coupler. The input FB current is transformed into Feedback voltage V_{FB} by the HIC internal resistor (SW1 is ON at normal). While, the reversed voltage waveform ($VOCPM$) of the drain current waveform is input to the input terminal of the FB comparator. It is the current mode controlling circuit that controls the peak value of the drain current by the FB comparator.

The FB current shall be decreased to nil value at the overload in Fig.12. At that time, the drain current is controlled under the current value regulated by the Overcurrent Protection Circuit. At the transition period from the normal load to the lowest load in Fig.12, the drain current is decreased since the FB current increases and V_{FB} rises. Where the V_{FB} exceeds the FB terminal threshold voltage ($V_{FB(OFF)}$, 1.5V TYP) such as at the lowest load, the thinned-out oscillating operation starts and the HIC controls the secondary side output voltage so as not to raise the secondary side output voltage.

5.10.4 OCP/BD Terminal (Pin 7)

The functions of OCP/BD terminal are categorized as Overcurrent Protection (OCP), Bottom-Skip, and Quasi-Resonant Operation control. Refer to item No. 8.5 for Bottom-Skip and Quasi-Resonant operation.

8.4.1. Minus-Detection Type OCP Circuit

The OCP of the STR-W6700 series is pulse-by-pulse type Overcurrent protection circuit, which detects the peak value of the MOSFET drain current per pulse and reverses oscillator output. As shown in Fig.14, overcurrent detecting resistors, R5, R4, and C5 are mounted externally. R4 and C5 construct the filter circuit that prevents malfunctions caused by the surge current generating at the MOSFET Turn-ON. As the Overcurrent Protection Circuit operation (OCP), it turns OFF the MOSFET at that time when OCP/BD terminal threshold voltage reaches $V_{OCPBD}(LIM)$ by the voltage generated at the overcurrent detecting resistor R5 after the switching current flows at the MOSFET ON.

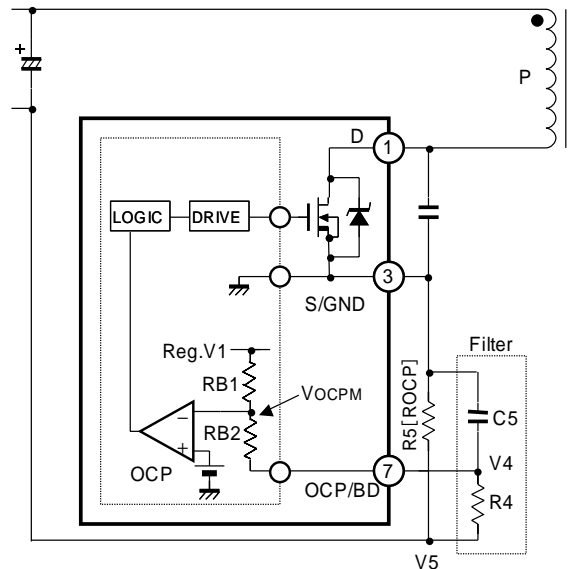

Fig.14. Minus-Detection OCP Circuit

The threshold voltage $V_{OCPBD}(LIM)$ of the OCP/BD terminal is set at $-0.95V$ (Typ). The OCP circuit adopts the minus-detection circuit, which provides the detecting voltage V_{OCPM} in the MIC by dividing the voltage (between V1 and R5) with RB1, RB2, and R4. Since the RB1 and RB2 are resistors incorporated in the HIC, taking the distributions of RB1 and RB2 (regulated as IOCPBD in the specs) into consideration, the value of R4 is to be between 100 to 330 Ohms in order to lower the influence from the distributions between RB1 and RB2.

5.10.5 Quasi-Resonant and Bottom-Skip Operation

5.10.5.1 Quasi-Resonant Operation

The Quasi-Resonant operation is to match the timing of the MOSFET Turn-ON to the bottom point of the voltage resonant waveform after a transformer releases the energy (i.e., 1/2 cycle of the resonant-frequency). As shown in Fig.15, the voltage resonant condenser C4 is connected between the drain and source, and the delay circuit, C10, D3, D4, and R9 are connected between the auxiliary winding D and OCP/BD terminal (Pin No.7). When the MOSFET is turned OFF, the Quasi-Resonant signal is made of the fly-back voltage generated in the auxiliary winding, which operates BD comparator, and it provides the Quasi-Resonant operation. Due to the operation of the delay circuit, even if the energy of the transformer is released to complete, the Quasi-Resonant signal imposed on Pin No. 7 terminal does not fall immediately. This is why the C10 is discharged by R4, and after a certain period, the voltage falls to the threshold voltage $V_{OCPBD(TH1)} \cong 0.4V$ and below. Consequently, the delay-time needs to be set by adjusting C10 monitoring the operating waveform in order to turn ON the MOSFET at that time when the V_{DS} of the MOSFET reaches the lowest point.

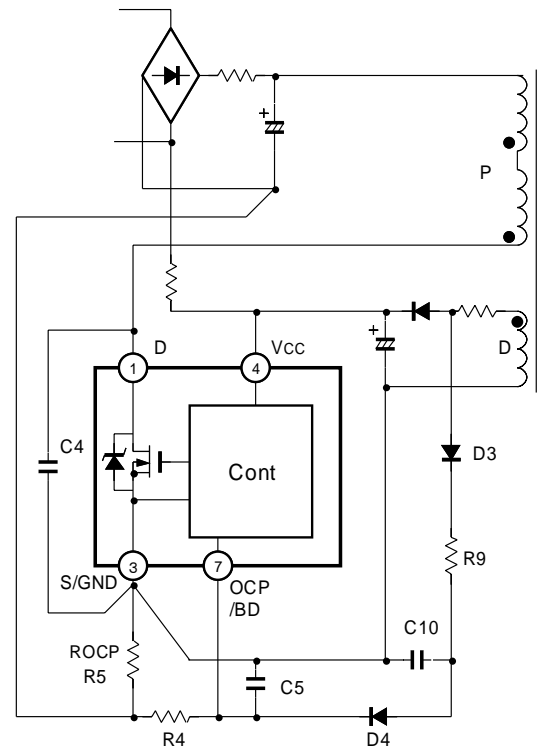

Fig.15. Quasi-Resonant and Delay Circuit

In addition to the Quasi-Resonant operation, in order to control the increase of the oscillating frequency at light to medium load, the Bottom-Skip operation widening OFF time is built-in in accordance with the load volumes. The switching timing between the Quasi-Resonant and Bottom-Skip operation is described in the item No. 8.5.2.

When the Quasi-Resonant signal voltage imposed on OCP/BD terminal is below $V_{OCPBD(TH2)} \cong 0.8V$, the internal oscillator starts PWM operation with the fixed oscillating frequency ($\cong 22kHz$). The PWM operation is also provided at power supply start-up or low auxiliary winding voltage such as winding-short, which lowers oscillating frequency, and the stress of the MOSFET is fairly reduced. After the Quasi-Resonant signal is over $V_{OCPBD(TH2)} \cong 0.8V$, the MOSFET remains OFF while $V_{OCPBD(TH1)} \cong 0.4V$ and more is imposed on. That is, the gap between $V_{OCPBD(TH1)}$ and $V_{OCPBD(TH2)}$ prevents the HIC from operating improperly.

While, in the setting up R9 and R4, the Quasi-Resonant signal imposed on the OCP/BD terminal needs to be 5V or below since the OCP/BD terminal voltage is maximum 5V. At the normal condition, it should be 1.5V approximately.

5.10.5.2 Bottom-Skip Operation (Switching from Quasi-Resonant Operation)

The basic bottom-skip operation is that the load of the secondary side is detected by the drain current value (actually OCP/BD terminal voltage), which switches to the Quasi-Resonant (at heavy load) and the Bottom-Skip operation (at light load). The timing of distinguishing is made by taking the OCP/BD terminal voltage in at start-down of the MOSFET gate voltage of the HIC. Furthermore, the number of start-down (OCP/BD terminal voltage is under $V_{OCPBD}(TH1)$) is measured, which makes the MOSFET turn ON in accordance with the mode described above.

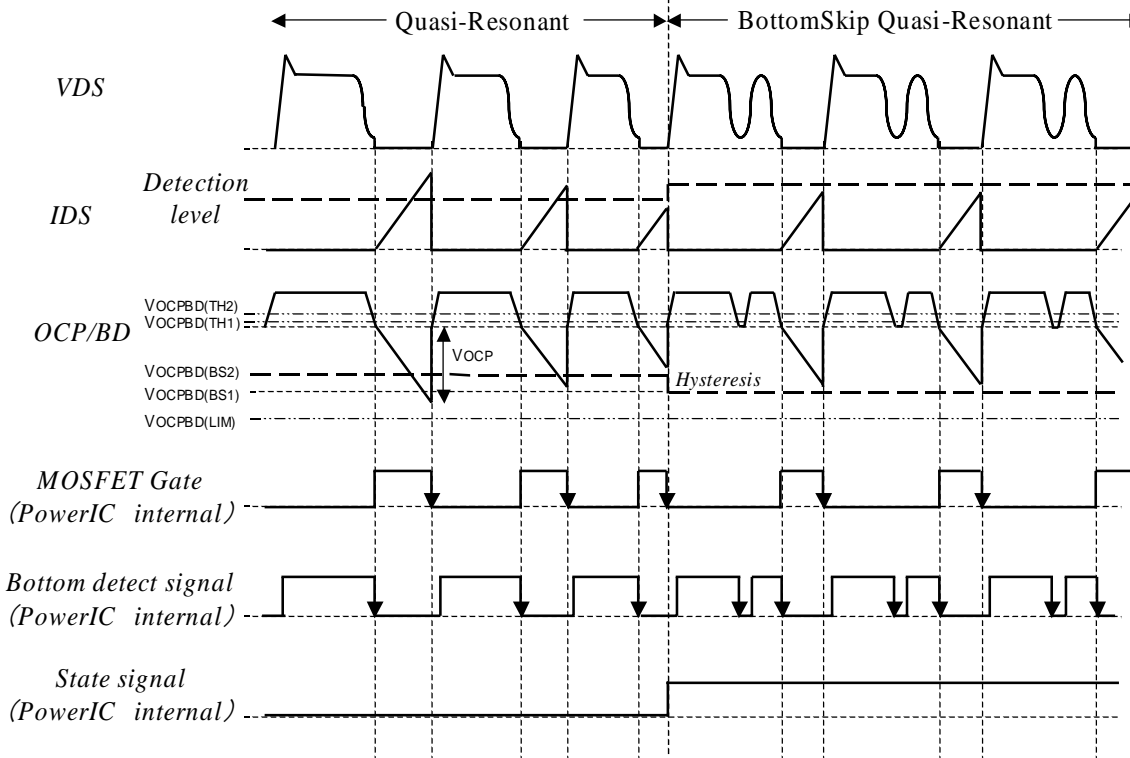

Fig.16. Bottom-Skip Quasi-Resonant Operation Timing Chart

1). Quasi-Resonant Operation ⇒ Bottom-Skip Operation

The Quasi-Resonant is operated under the mode that V_{OCP} is higher than $V_{OCPBD}(BS2)$ at the absolute rating. Where the load becomes lighter than that of the mode, the drain current falls. As the result, the mode is switched to the Bottom-Skip operation when the V_{OCP} becomes lower than $V_{OCPBD}(BS2)$ at the absolute rating, and the standard voltage is automatically changed to $V_{OCPBD}(BS1)$. Fig 16 shows the switching timing chart from the Quasi-Resonant to the Bottom-Skip operation.

2). Bottom-Skip Operation ⇒ Quasi-Resonant Operation

The Bottom-Skip is operated under the mode that V_{OCP} is lower than $V_{OCPBD}(BS1)$ at the absolute rating. Where the load becomes higher than that of the mode, the drain current rises. As the result, the mode is switched to the Quasi-Resonant operation when V_{OCP} becomes higher than $V_{OCPBD}(BS1)$ at the absolute

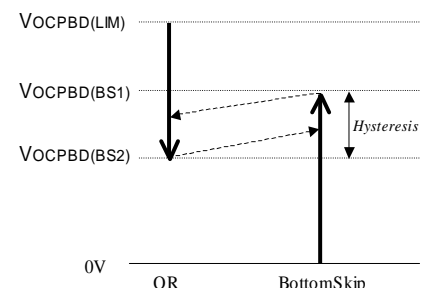

Fig.17. Operation Mode switching

rating, and the standard voltage is automatically changed to VOCPBD(BS2).

Besides, the VOCP is OCP/BD terminal voltage at that time when the MOSFET gate voltage starts down.

As described above, the standard voltage (VOCPBD(BS1), VOCPBD(BS2)) realizing the Bottom-Skip operation provides the hysteresis operation automatically and makes it possible to have the stabilized operation. Fig.17 shows the above operation switching changing mode.

5.10.6 Stand-By Operation

The STR-W6700 series contains the burst-mode switching function to reduce the power dissipation at stand-by mode. At the stand-by with a remote controller, the switching mode is set in the secondary side, which makes the HIC switch to the burst-mode automatically by reducing the output voltage.

The transformer winding voltage falls reducing the output voltage by switching in the secondary side, and it reduces the primary side auxiliary winding voltage, which cuts off the power supply from the auxiliary winding to VCC terminal (Pin No. 4), and the VCC terminal voltage is reduced by the HIC's dissipation current itself. Where the VCC terminal (Pin No.4) voltage reaches the operation stop power supply voltage (9.6V TYP), the HIC stops its operation, and the dissipation current of the HIC turns circuit current (ICC(S)) at stand-by non-operation, and with the charging to the back-up condenser through a start-up resistor, the VCC terminal voltage (Pin No.4) rises again, and the HIC starts its operation immediately after the VCC terminal voltage reaches the operation start-up power supply voltage. Repeating the above cycles, the HIC has the power supply continue the burst-mode.

In order to reduce the transformer's magnetostriction noises at the burst-mode, by lowering the voltage gap between the operation start-up power supply voltage at the stand-by and the operation stop voltage, the operation frequency is increased and switched to the mode controlling the switching current as low as possible without increasing the loss at the start-up resistor.

This switching is made by detecting that the FB terminal voltage exceeds the FB stand-by operation threshold voltage VFB(S), and the operation voltage width of the VCC terminal is determined as "the power supply voltage interval 1.5V(TYP) at stand-by" and the width is approximately one fifth compared to the normal operation.

In the transition period from the normal to stand-by operation, the output voltage continues falling because the HIC's oscillation is suspended by the feedback current. Thus, it is inevitable to secure the voltage exceeding the required output voltage of secondary side in the period until the HIC starts the stand-by operation.

Meanwhile, in the transition period from the stand-by to normal operation, the output voltage

continues falling because the HIC's oscillation is suspended until the Vcc terminal voltage (Pin 4) reaches the operation start-up voltage 18V (TYP). Thus it is required to secure the voltage exceeding the required output voltage of secondary side.

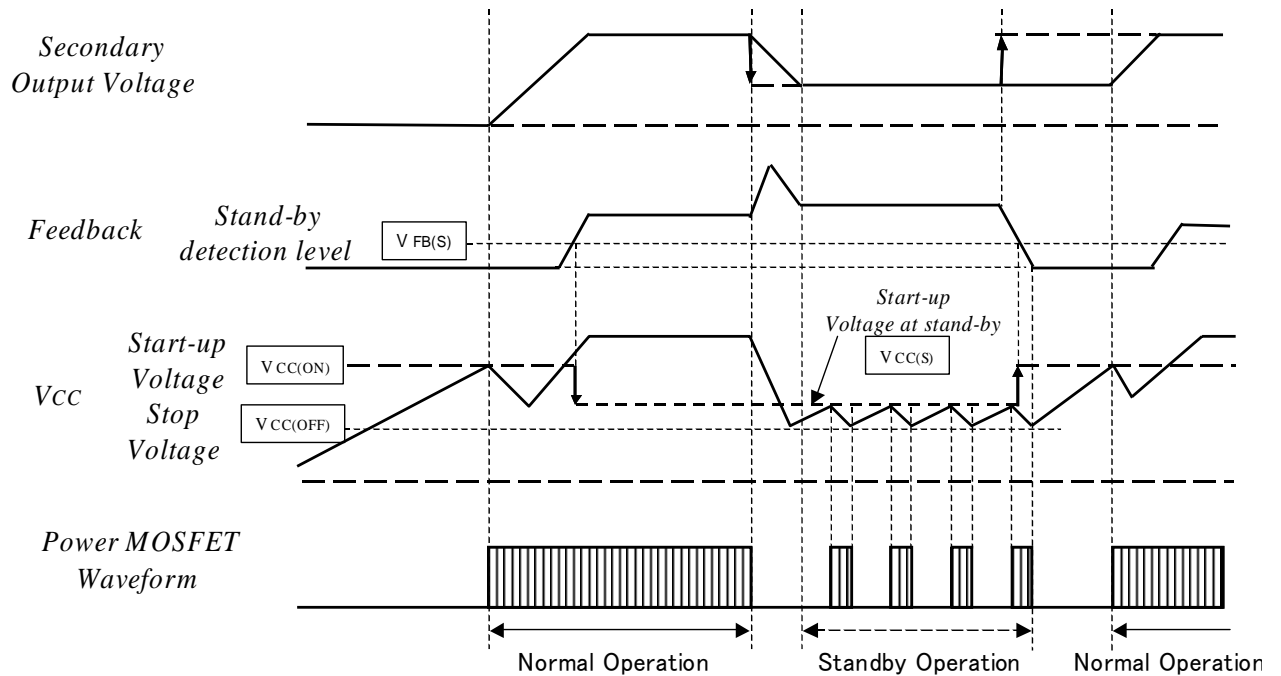

Fig.18. Timing-Chart at Operation Switching

At the stand-by mode, as mentioned above, due to the burst-mode of the HIC's intermittent operation, the output voltage falls since the HIC stops its operation during the oscillation stop period. While, during the stand-by operation, the intermittent operation repeating oscillation and stop through the start-up resistor is provided because the transformer's auxiliary winding voltage supplying the power supply to the HIC is extremely decreased. Accordingly, the load except stand-by load cannot be taken out at the stand-by operation (the period of intermittent operation). Where the load excluding the stand-by load is imposed on the transition period from the stand-by to normal operation, the incomplete start-up might be occurred. Thus, for the switching to the normal mode, it is required to have the sequence (no load at stand-by should be imposed on the normal mode), and the switching needs to be made after the power supply is completely turned to the normal mode.

5.10.7 Step-Drive Circuit

The STR-W6700 series reduces noises at Turn-ON by adopting the step-drive circuit for the MOSFET drive circuit as shown in Fig. 19. The drive current at Turn-ON is controlled at low by RG1 first, and it makes the gate voltage increase gradually, and the gate voltage is increased rapidly through RG1 + RG2 after 0.8 μ sec approximately. While, the MOSFET drive voltage adopts the constant voltage drive circuit maintained at $V_{DRM}=7.6V_{typ}$, and it is not affected to VCC. The MOSFET gate electric charge is discharged rapidly through RG3 when the MOSFET is turned OFF. That is, in the STR-W6700 series' drive circuit, the gate

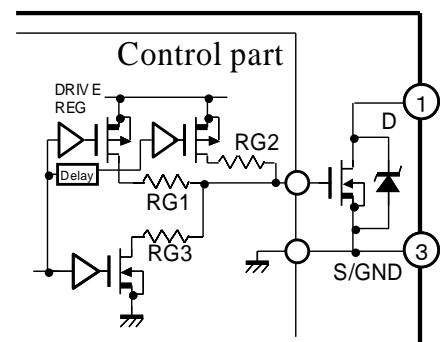

Fig.19. Step-Drive Circuit

voltage imposed on the MOSFET is shifted with the two steps, which lowers the gate voltage at Turn ON and controls the surge current flowing at Turn ON, and provides the ideal drive circuit securing the sufficient gate voltage at normal drive mode.

5.10.8 Maximum ON Time Controlling Function

The MOSFET ON Time is controlled in the transition mode such as a low input voltage or AC input ON and OFF. The maximum ON Time is set at about 80% of the oscillation cycle ($= 1/f_{OSC}$ approx. 45 μ sec) and approximately 35 μ sec (TYP). While, for the design of power supply, it is also required to monitor the MOSFET ON time at maximum load and input voltage minimum.

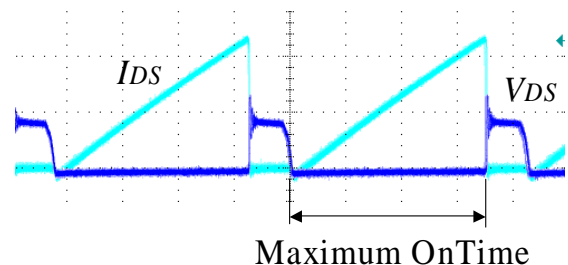

Fig.20. Maximum ON Time

6 SERVICE PARTS LIST

Caution:In this Service Manual, some parts can be changed for improving, their performance without notice in the parts list. So, if you need the latest parts information, please refer to PPL(Parts Price List)in Service information Center(<http://svc.dwe.co.kr>)

Important Safety Notice

Components Identified by Δ mark have special characteristics important for safety. When replacing any of these components, use only manufacturers specified parts. In case of Ordering these spare parts, please always add the complete Model-Type number to your order.

6.1 DTF-2950

LOC	PART CODE	PART NAME	DESCRIPTION	REMARK
ZZ100	PTACPWT2950F	ACCESSORY AS	DTF-2950FZF-SB	
12000	48B5849C1001	TRANSMITTER REMOCON	R-49C10	
13000	4850Q00910	BATTERY	AAA R03 SUPERGARD/ROCKET	
14000	4858213801	BAG INSTRUCTION	L. D. P. E. TO. 05X250X400	
ZZ120	PTBCSHL2950S	COVER BACK AS	DTL-2950FZF-S	
M211	4852174911	COVER BACK	2950 HIPS GY8301A	
M211D	4857817610	CLOTH BLACK	"300 MM 20"	
M541	4855415800	S/PLATE	150ART P/E FILM (C7V)	
M542	48558002207	LABEL SERIAL	ART 90	
ZZ130	PTCACAT2950FSS	CABINET AS	DTF-2950FZS-SB	
M201A	4856017752	SCREW CRT FIX	6X35 L120 YL 3CR	
M201B	4856219502	WASHER RUBBER	CR T2.0 BLACK	
M201C	7178301051	SCREW TAPPTITE	TT2 WAS 3X10 MFZN 3CR	
M201D	4856017800	SCREW SPKR FIX	SWRM+SECC 3CR	
M201E	7178301051	SCREW TAPPTITE	TT2 WAS 3X10 MFZN 3CR	
M211A	7172401652	SCREW TAPPTITE	TT2 TRS 4X16 MFZN BK 3CR	
M211B	7172401252	SCREW TAPPTITE	TT2 TRS 4X12 MFZN BK 3CR	
M352	2TF01612CL	TAPE FILAMENT	12MMX55ME CLEAR	
M481	485487071101	BUTTON POWER	2950 GY340A+SV2405BP	
M481A	4856716000	SPRING	14Q1/M3 SWPA PIE0.5	
M561	48556293SD02	MARK BRAND	"DAEWOO 25"29"32" NEW"	
PWC1	4859906210	CORD POWER	WF 6-LO (LOMAX NEW)	Δ
SP01A	4856017800	SCREW SPKR FIX	SWRM+SECC 3CR	
SP02A	4856017800	SCREW SPKR FIX	SWRM+SECC 3CR	
V901	4859651760	"CRT (SAMSUNG 29")"	A68QFZ893X002	Δ
ZZ131	58G0000194	COIL DEGAUSSING	DC-29SF BF AL	Δ
ZZ132	48519A7810	CRT GROUND AS	2903S-1015-1P	
ZZ200	PTFMSJT2950S	MASK FRONT AS	DTF-2950FZF-SB	
M201	4852092411	MASK FRONT	2950 HIPS GY	
ZZ201	PTSPPPWT2950F	SPEAKER AS	DTF-2950FZF-SB	
51100	4850704S28	CONN AS	YH025-04+35089+ULW=600	
SP01	48A8311400	SPEAKER SYSTEM	SS-58126F04C	
SP02	48A8311400	SPEAKER SYSTEM	SS-58126F04C	
ZZ280	PTU1MST2950FF	PCB UNION MANUAL AS	DTF-2950FZF-SB	
C801	CL1UC3474M	C LINE ACROSS	0.47MF 1J(UCVS/NDF/SV	Δ
DL01	DH1L25RS—	LED(RED)	HI-L25RS	
DL02	DH1L25G—	"LED (R,G-3 COLOR)"	HI-L25G	
F801	5FSCB4022R	FUSE CERA	SEMKO F4AH 4A 250V MF51	Δ
HP01	4859105240	JACK PHONO	LGT1516-0100	
I703	1TSOP4838Y	IC PREAMP	TSOP34838YA1	
JPA3	4859105450	JACK PIN BOARD	YSC03P-4120-9S	
JPA4	4859105340	JACK S-VHS	DSW-10 (STRAIGHT)	
LF801	5PLF24A3—	FILTER LINE	LF-24A3	Δ
LF802	58C0000153	COIL CHOKE PFC	6001.0016B	Δ
M231	485233251102	PANEL CTRL	2950 ABS GY	
M231A	7178301051	SCREW TAPPTITE	TT2 WAS 3X10 MFZN 3CR	
M351	485356811101	HOLDER SENSOR	2950 GY340A(SILVER)	
M491	485496331101	BUTTON CTRL	2950 ABS GY	
M551	485555530001	DECO SENSOR	2950 GPPS GY9304AT	
P702A	4850703N43	CONNECTOR	YH025-03+YBH250-03+ULW=500	
P703A	4850704S02	CONN AS	YH025-04+YST025+ULW=200	
P801	4859287320	CONN WAFER	MKS2822 (LOMAX NEW TYPE)	
P803	4859238620	CONN WAFER	YPW500-02	
PA01A	4950712003	CONNECTOR	YH025-12+YST250+ULW=450	
SW801	5540101146	SW POWER PUSH	SS-160-7-B	Δ
ZZ200	PTU1JBT2950FF	PCB UNION EYE LET AS	DTF-2950FZF-SB	
E1	4856310300	EYE LET	BSR T0.2 (R1.6) SMALL	
E2	4856310300	EYE LET	BSR T0.2 (R1.6) SMALL	
E3	4856310300	EYE LET	BSR T0.2 (R1.6) SMALL	

LOC	PART CODE	PART NAME	DESCRIPTION	REMARK
E4	4856310300	EYE LET	BSR T0.2 (R1.6) SMALL	
E5	4856310300	EYE LET	BSR T0.2 (R1.6) SMALL	
E6	4856310300	EYE LET	BSR T0.2 (R1.6) SMALL	
E7	4856310300	EYE LET	BSR T0.2 (R1.6) SMALL	
ZZ200	PTU1JRT2950FF	PCB UNION RADIAL AS	DTF-2950FZF-SB	
C690	CEXF1H479V	C ELECTRO	50V RSS 4.7MF (5*11) TP	
C691	CEXF1H479V	C ELECTRO	50V RSS 4.7MF (5*11) TP	
C770	CEXF1C101V	C ELECTRO	16V RSS 100MF (6.3X11) TP	
CA21	CCXB1H472K	C CERA	50V B 4700PF K (TAPPING)	
F801A	4857415001	CLIP FUSE	PFC5000-0702	
F801B	4857415001	CLIP FUSE	PFC5000-0702	
Q506	T2SC5343Y-	TR	2SC5343Y	
Q507	T2SA1980Y-	TR	2SA1980Y	
SW700	5S50101290	SW TACT	SKHV10910A	
SW701	5S50101290	SW TACT	SKHV10910A	
SW702	5S50101290	SW TACT	SKHV10910A	
SW703	5S50101290	SW TACT	SKHV10910A	
SW704	5S50101290	SW TACT	SKHV10910A	
SW705	5S50101290	SW TACT	SKHV10910A	
Z601	5PXF1B471M	FILTER EMI	CFI 06 B 1H 470PF	
Z602	5PXF1B471M	FILTER EMI	CFI 06 B 1H 470PF	
Z603	5PXF1B471M	FILTER EMI	CFI 06 B 1H 470PF	
Z604	5PXF1B471M	FILTER EMI	CFI 06 B 1H 470PF	
ZZ200	PTU1JAT2950FF	PCB UNION AXIAL AS	DTF-2950FZF-SB	
10	2TM14006LB	TAPE MASKING	3M #232 6.0X2000M (WITH GLUE)	
20	2TM10006LB	TAPE MASKING	3M #232-NAIP-C 6.2X2000M (W/O GLUE)	
A001	4859816424	PCB UNION	246X246(120X210X2)D1B	Δ
C608	CCZB1H471K	C CERA	50V B 470PF K (AXIAL)	
C609	CCZB1H471K	C CERA	50V B 470PF K (AXIAL)	
CA20	CCZB1H472K	C CERA	50V B 4700PF K (AXIAL)	
DA21	CCZB1H471K	C CERA	50V B 470PF K (AXIAL)	
DA22	CCZB1H471K	C CERA	50V B 470PF K (AXIAL)	
J001	85801060GY	WIRE COPPER	1/0.6 TIN COATING	
L701	5CP2560K02	COIL PEAKING	56UH 3.5MM K (LAL02TB)	
R530	RD-AZ151J-	R CARBON FILM	1/6 150 OHM J	
R531	RD-AZ750J-	R CARBON FILM	1/6 75 OHM J	
R532	RD-AZ102J-	R CARBON FILM	1/6 1K OHM J	
R533	RD-AZ102J-	R CARBON FILM	1/6 1K OHM J	
R608	RD-2Z151J-	R CARBON FILM	1/2 150 OHM J	
R609	RD-2Z151J-	R CARBON FILM	1/2 150 OHM J	
R701	RD-AZ101J-	R CARBON FILM	1/6 100 OHM J	
R721	RD-AZ181J-	R CARBON FILM	1/6 180 OHM J	
R722	RD-AZ221J-	R CARBON FILM	1/6 220 OHM J	
R723	RD-AZ331J-	R CARBON FILM	1/6 330 OHM J	
R724	RD-AZ471J-	R CARBON FILM	1/6 470 OHM J	
R725	RD-AZ681J-	R CARBON FILM	1/6 680 OHM J	
R802	RD-2Z824J-	R CARBON FILM	1/2 820K OHM J	
RA22	RD-AZ750J-	R CARBON FILM	1/6 75 OHM J	
ZZ290	PTMPMST2950FS	PCB MAIN MANUAL AS	DTF-2950FZS-SB	
10	2193110001	SOLDER WIRE	SN-3.0AG (NP303T) 3.0	
20	2193110002	SOLDER WIRE	SN-3.0AG-0.5CU (DHB-RMA3)	
30	2291050620	FLUX SOLDER	DF-2810U (0.810)	
40	2291050314	FLUX SOLVENT	IM-1000	
C315	CEXF2A470V	C ELECTRO	100V RSS 47MF (10X16) TP	
C402	CMYH3C752J	C MYLAR	1.6KV 7500PF J (BUP)	
C404	CMYH3C562J	C MYLAR	1.6KV 5600PF J (BUP)	
C405	CMXE2G243J	C MYLAR	400V PU 0.024MF J	
C408	CMYE2G184J	C MYLAR	400V PU 0.18MF J	
C411	CMYF2E105J	C MYLAR	250V MPP 1MF J	
C415	CEXF2E100V	C ELECTRO	250V RSS 10MF (10X20) TP	
C418	CEYD1H689W	C ELECTRO	50V RHD 6.8MF (16X35.5)	

CP-850/F Service Manual

LOC	PART CODE	PART NAME	DESCRIPTION	REMARK
C604	CEXF1E102V	C ELECTRO	25V RSS 1000MF (13X20) TP	
C805	CEYD2G181D	C ELECTRO	400V FHS 180MF	
C812	CH1BFE472M	C CERA AC	AC400V 4700PF M UICV	△
C813	CEXF2E101V	C ELECTRO	250V RSS 100MF 18X35.5	
C814	CEYF2E470V	C ELECTRO	250V RSS 47MF (16X25)	
C820	CCXR3D221K	C CERA	2KV R 220PF K125C	
C823	CEXF1E222V	C ELECTRO	25V RSS 2200MF (16X25) TP	
C840	CEXF1C102V	C ELECTRO	16V RSS 1000MF (10X20) TP	
C861	CEXF1E102C	C ELECTRO	25V RUS 1000MF 13X20 TP	
C899	CMXF2J333J	C MYLAR	630V MPP 0.033MF J	
CP01	CMYF2G224J	C MYLAR	400V MPU 0.22MF J	
CP02	CMXE2J222J	C MYLAR	630V PU 2200PF	
CP04	CEXF1H221V	C ELECTRO	50V RSS 220MF (10X16) TP	
CP07	CMYF2J154J	C MYLAR	630V MPP 0.15MF J	
D401	DDTV1500MD	DIODE	DDTV1500MD TO-220AC01	
D404	DFMP3FU—	DIODE	FMP3FU	
D404A	4857027603	HEAT SINK	AL EX	
D404B	7174301051	SCREW TAPPTITE	TT2 RND 3X10 MFZN 3CR	
D406	DRGP30J—	DIODE	RG30J	
D820	DRGP30J—	DIODE	RG30J	
D860	DRGP30J—	DIODE	RG30J	
D870	DRGP30J—	DIODE	RG30J	
I301	1TDA8358J-	IC VERTICAL	TDA8358J	
I301A	4857028219	HEAT SINK	AL EX ANODIZING	
I301B	7174301051	SCREW TAPPTITE	TT2 RND 3X10 MFZN 3CR	
I601	1MSP3410V3	IC SOUND	MSP3410G-V3	
I602	1TDA8946J-	IC AUDIO	TDA8946J	
I602A	4857028215	HEAT SINK	AL EX NO ANODOZING	
I602B	7174301051	SCREW TAPPTITE	TT2 RND 3X10 MFZN 3CR	
I701	1SDA555XFL	IC MICOM OTP	SDA555XFL/PO	
I702	1M24C16BN6	IC MEMORY	M24C16WRN6	
I801	1STRW6754-	IC POWER	STR-W6754	
I801A	4857024600	HEAT SINK	AL EX B/K	
I801B	7174300851	SCREW TAPPTITE	TT2 RND 3X8 MFZN 3CR	
I804	1LTV817C—	IC PHOTO COUPLER	LTV-817C	△
I806	1DP125—	IC ERROR AMP	DP125	
I820	1S7805P1C-	IC REGULATOR	S7805PIC 5.0V 1.0A	
I821	1K78R33—	IC REGULATOR	KIA78R33AP	
I822	1K78R08—	IC REGULATOR	KIA78R08API	
I822A	4857026900	HEAT SINK	AL EX	
I822B	7174300851	SCREW TAPPTITE	TT2 RND 3X8 MFZN 3CR	
I824	1K78R018P1	IC REGULATOR	KIA78R018P1	
I825	1K78R05—	IC REGULATOR	KIA78R05P1	
I826	1A1117P133	IC REGULATOR	KIA1117P133 3.3V TO-220IS	
JPA1	4859200401	SOCKET RGB	SR-21A1 (ANGLE TYPE)	
JPA2	4859200401	SOCKET RGB	SR-21A1 (ANGLE TYPE)	
L150	58E0000041	COIL AFT	TRF-A005	
L401	58H0000054	COIL H-LINEARITY	TRL-040F	
L403	58C0000130	COIL CHOKE	CH-161A	
P401	4850705S04	CONN AS	YH025-05+YST025+ULW=400	
P402	4859242420	CONN WAFER	YFW800-04	
P404	4859242220	CONN WAFER	YFW800-02	
P501	4850708N15	CONNECTOR	YH025-08+YBNH250+USW=600	
P601	4859231720	CONN WAFER	YW025-04	
P702	4859231620	CONN WAFER	YW025-03	
P703	4859231720	CONN WAFER	YW025-04	
P802	4859242220	CONN WAFER	YFW800-02	
P804	4859238620	CONN WAFER	YPW500-02	
PA01	4859235520	CONN WAFER	YW025-12	
Q401	TST2310DH1	TR	ST2310DHI	
Q401A	4857033201	HEAT SINK	AL EX BK (ANODIZING)	
Q401B	7174301051	SCREW TAPPTITE	TT2 RND 3X10 MFZN 3CR	
Q807	TKTA1659AY	TR	KTA1659AY	
QP03	T1RF640N—	FET	IRF640NPBF	
QP03A	4857026900	HEAT SINK	AL EX	
QP03B	7174300851	SCREW TAPPTITE	TT2 RND 3X8 MFZN 3CR	
R388	RW02Y678FS	R WIRE WOUND	2W 0.67 OHM F SMALL	
R399	RS02Y829JS	R M-OXIDE FILM	2W 8.2 OHM J SMALL	
R407	RF01Y129JA	R FUSIBLE	1W 1.2 OHM J A CURVE	
R444	RS02Y330JS	R M-OXIDE FILM	2W 33 OHM J SMALL	

LOC	PART CODE	PART NAME	DESCRIPTION	REMARK
R801	DJ5020M270	POSISTOR	J502P72D070M270	△
R803	RS02Y338JS	R M-OXIDE FILM	2W 0.33 OHM J SMALL	
R806	RS02Y228JS	R M-OXIDE FILM	2W 0.22 OHM J SMALL	
R819	RX07B339JP	R CEMENT	7W 3.3 OHM J BEN 15MM 4P	
R841	RS02Y309JS	R M-OXIDE FILM	2W 3 OHM J SMALL	
R850	RS02Y569JS	R M-OXIDE FILM	2W 5.6 OHM J SMALL	
R852	RS02Y569JS	R M-OXIDE FILM	2W 5.6 OHM J SMALL	
R854	RS02Y569JS	R M-OXIDE FILM	2W 5.6 OHM J SMALL	
R885	RS02Y339JS	R M-OXIDE FILM	2W 3.3 OHM J SMALL	
R899	RS02Y683J-	R M-OXIDE FILM	2W 68K OHM J	
SF1	5PK3953M—	FILTER SAW	K3953M	
SF2	5PK9650M—	FILTER SAW	K9650M	
T401	50D25A2—	TRANS DRIVE	TD-25A2	
T402	50H0000317	FBT	1372.0136	△
T801	50M4818A2-	TRANS SMPS	2094.0119	△
U100	485924930	TUNER VARACTOR	UV1316/AI-4	
X501	5XE20R250E	CRYSTAL QUARTZ	HC-49/U 20.2500MHZ 30PPM	
X601	5XE18R432E	CRYSTAL QUARTZ	HC-49/U 18.43200MHZ 30PPM	
Y801	5SC0101003	SW RELAY	DG12D1-0(M)-II 1C-1P	△
Z153	5PXT5R5MB	FILTER CERA	XT 5.5MB (TAPPING)	
Z2200	PTMPJBT2950FS	PCB MAIN EYE LET AS	DTF-2950FZS-SB	
E1	4856310600	EYE LET	BSR 2.3(R2.3) BIG	
E10	4856310300	EYE LET	BSR T0.2 (R1.6) SMALL	
E11	4856310300	EYE LET	BSR T0.2 (R1.6) SMALL	
E12	4856310600	EYE LET	BSR 2.3(R2.3) BIG	
E13	4856310600	EYE LET	BSR 2.3(R2.3) BIG	
E14	4856310600	EYE LET	BSR 2.3(R2.3) BIG	
E15	4856310600	EYE LET	BSR 2.3(R2.3) BIG	
E16	4856310600	EYE LET	BSR 2.3(R2.3) BIG	
E17	4856310600	EYE LET	BSR 2.3(R2.3) BIG	
E18	4856310600	EYE LET	BSR 2.3(R2.3) BIG	
E19	4856310600	EYE LET	BSR 2.3(R2.3) BIG	
E2	4856310600	EYE LET	BSR 2.3(R2.3) BIG	
E20	4856310600	EYE LET	BSR 2.3(R2.3) BIG	
E21	4856310600	EYE LET	BSR 2.3(R2.3) BIG	
E22	4856310600	EYE LET	BSR 2.3(R2.3) BIG	
E23	4856310600	EYE LET	BSR 2.3(R2.3) BIG	
E24	4856310600	EYE LET	BSR 2.3(R2.3) BIG	
E25	4856310600	EYE LET	BSR 2.3(R2.3) BIG	
E26	4856310600	EYE LET	BSR 2.3(R2.3) BIG	
E27	4856310300	EYE LET	BSR T0.2 (R1.6) SMALL	
E28	4856310300	EYE LET	BSR T0.2 (R1.6) SMALL	
E29	4856310300	EYE LET	BSR T0.2 (R1.6) SMALL	
E3	4856310600	EYE LET	BSR 2.3(R2.3) BIG	
E30	4856310300	EYE LET	BSR T0.2 (R1.6) SMALL	
E31	4856310300	EYE LET	BSR T0.2 (R1.6) SMALL	
E32	4856310300	EYE LET	BSR T0.2 (R1.6) SMALL	
E33	4856310300	EYE LET	BSR T0.2 (R1.6) SMALL	
E34	4856310300	EYE LET	BSR T0.2 (R1.6) SMALL	
E35	4856310300	EYE LET	BSR T0.2 (R1.6) SMALL	
E36	4856310600	EYE LET	BSR 2.3(R2.3) BIG	
E37	4856310600	EYE LET	BSR 2.3(R2.3) BIG	
E38	4856310600	EYE LET	BSR 2.3(R2.3) BIG	
E39	4856310600	EYE LET	BSR 2.3(R2.3) BIG	
E4	4856310600	EYE LET	BSR 2.3(R2.3) BIG	
E40	4856310300	EYE LET	BSR T0.2 (R1.6) SMALL	
E41	4856310300	EYE LET	BSR T0.2 (R1.6) SMALL	
E42	4856310300	EYE LET	BSR T0.2 (R1.6) SMALL	
E43	4856310300	EYE LET	BSR T0.2 (R1.6) SMALL	
E48	4856310300	EYE LET	BSR T0.2 (R1.6) SMALL	
E49	4856310300	EYE LET	BSR T0.2 (R1.6) SMALL	
E5	4856310600	EYE LET	BSR 2.3(R2.3) BIG	
E50	4856310300	EYE LET	BSR T0.2 (R1.6) SMALL	
E51	4856310300	EYE LET	BSR T0.2 (R1.6) SMALL	
E52	4856310300	EYE LET	BSR T0.2 (R1.6) SMALL	
E53	4856310300	EYE LET	BSR T0.2 (R1.6) SMALL	
E54	4856310300	EYE LET	BSR T0.2 (R1.6) SMALL	
E56	4856310300	EYE LET	BSR T0.2 (R1.6) SMALL	
E57	4856310300	EYE LET	BSR T0.2 (R1.6) SMALL	

LOC	PART CODE	PART NAME	DESCRIPTION	REMARK
E58	4856310300	EYE LET	BSR T0.2 (R1.6) SMALL	
E6	4856310600	EYE LET	BSR 2.3(R2.3) BIG	
E62	4856310300	EYE LET	BSR T0.2 (R1.6) SMALL	
E63	4856310300	EYE LET	BSR T0.2 (R1.6) SMALL	
E7	4856310600	EYE LET	BSR 2.3(R2.3) BIG	
E8	4856310300	EYE LET	BSR T0.2 (R1.6) SMALL	
E9	4856310300	EYE LET	BSR T0.2 (R1.6) SMALL	
ZZ200	PTMPJ2T2950FS	PCB CHIP MOUNT B AS	DTF-2950FZS-SB	
CC01	HCBK471KBA	C CHIP CERA	50V X7R 470PF K 1608	
CC02	HCBK471KBA	C CHIP CERA	50V X7R 470PF K 1608	
CC03	HCBK471KBA	C CHIP CERA	50V X7R 470PF K 1608	
CC04	HCBK471KBA	C CHIP CERA	50V X7R 470PF K 1608	
CC05	HCBK471KBA	C CHIP CERA	50V X7R 470PF K 1608	
CC06	HCBK471KBA	C CHIP CERA	50V X7R 470PF K 1608	
CC07	HCBK471KBA	C CHIP CERA	50V X7R 470PF K 1608	
CC08	HCBK471KBA	C CHIP CERA	50V X7R 470PF K 1608	
CC10	HCBK102KBA	C CHIP CERA	50V X7R 1000PF K 1608	
CC101	HCBK102KBA	C CHIP CERA	50V X7R 1000PF K 1608	
CC103	HCBK102KBA	C CHIP CERA	50V X7R 1000PF K 1608	
CC110	HCBK103KBA	C CHIP CERA	50V X7R 0.01MF K 1608	
CC115	HCBK104KBA	C CHIP CERA	50V X7R 0.1MF K 1608	
CC117	HCBK103KBA	C CHIP CERA	50V X7R 0.01MF K 1608	
CC119	HCBK103KBA	C CHIP CERA	50V X7R 0.01MF K 1608	
CC127	HCBK102KBA	C CHIP CERA	50V X7R 1000PF K 1608	
CC129	HCBK103KBA	C CHIP CERA	50V X7R 0.01MF K 1608	
CC13	HCBK102KBA	C CHIP CERA	50V X7R 1000PF K 1608	
CC136	HCBK104KBA	C CHIP CERA	50V X7R 0.1MF K 1608	
CC14	HCBK102KBA	C CHIP CERA	50V X7R 1000PF K 1608	
CC15	HCBK102KBA	C CHIP CERA	50V X7R 1000PF K 1608	
CC158	HCBK104KBA	C CHIP CERA	50V X7R 0.1MF K 1608	
CC16	HCBK102KBA	C CHIP CERA	50V X7R 1000PF K 1608	
CC160	HCBK103KBA	C CHIP CERA	50V X7R 0.01MF K 1608	
CC166	HCQK470JBA	C CHIP CERA	50V CH 47PF J 1608	
CC177	HCQK470JBA	C CHIP CERA	50V CH 47PF J 1608	
CC18	HCBK102KBA	C CHIP CERA	50V X7R 1000PF K 1608	
CC19	HCBK102KBA	C CHIP CERA	50V X7R 1000PF K 1608	
CC501	HCBK102KBA	C CHIP CERA	50V X7R 1000PF K 1608	
CC502	HCBK102KBA	C CHIP CERA	50V X7R 1000PF K 1608	
CC503	HCFF334ZBA	C CHIP CERA	16V Y5V 0.33MF Z 1608	
CC504	HCQK100JBA	C CHIP CERA	50V CH 10PF J 1608	
CC505	HCBK102KBA	C CHIP CERA	50V X7R 1000PF K 1608	
CC506	HCBK104KBA	C CHIP CERA	50V X7R 0.1MF K 1608	
CC507	HCBK102KBA	C CHIP CERA	50V X7R 1000PF K 1608	
CC508	HCBK102KBA	C CHIP CERA	50V X7R 1000PF K 1608	
CC509	HCBK102KBA	C CHIP CERA	50V X7R 1000PF K 1608	
CC511	HCBK102KBA	C CHIP CERA	50V X7R 1000PF K 1608	
CC512	HCBK102KBA	C CHIP CERA	50V X7R 1000PF K 1608	
CC513	HCBK102KBA	C CHIP CERA	50V X7R 1000PF K 1608	
CC514	HCBK104KBA	C CHIP CERA	50V X7R 0.1MF K 1608	
CC515	HCQK470JBA	C CHIP CERA	50V CH 47PF J 1608	
CC516	HCQK470JBA	C CHIP CERA	50V CH 47PF J 1608	
CC517	HCBK104KBA	C CHIP CERA	50V X7R 0.1MF K 1608	
CC518	HCBK104KBA	C CHIP CERA	50V X7R 0.1MF K 1608	
CC521	HCBK104KBA	C CHIP CERA	50V X7R 0.1MF K 1608	
CC522	HCBK104KBA	C CHIP CERA	50V X7R 0.1MF K 1608	
CC523	HCBK104KBA	C CHIP CERA	50V X7R 0.1MF K 1608	
CC524	HCBK102KBA	C CHIP CERA	50V X7R 1000PF K 1608	
CC526	HCQK220JBA	C CHIP CERA	50V CH 22PF J 1608	
CC527	HCQK220JBA	C CHIP CERA	50V CH 22PF J 1608	
CC528	HCBK102KBA	C CHIP CERA	50V X7R 1000PF K 1608	
CC549	HCBK104KBA	C CHIP CERA	50V X7R 0.1MF K 1608	
CC550	HCBK104KBA	C CHIP CERA	50V X7R 0.1MF K 1608	
CC551	HCBK104KBA	C CHIP CERA	50V X7R 0.1MF K 1608	
CC552	HCQK270JBA	C CHIP CERA	50V CH 27PF J 1608	
CC553	HCQK270JBA	C CHIP CERA	50V CH 27PF J 1608	
CC556	HCBK102KBA	C CHIP CERA	50V X7R 1000PF K 1608	
CC560	HCBK102KBA	C CHIP CERA	50V X7R 1000PF K 1608	
CC561	HCBK104KBA	C CHIP CERA	50V X7R 0.1MF K 1608	
CC567	HCBK102KBA	C CHIP CERA	50V X7R 1000PF K 1608	
CC568	HCBK104KBA	C CHIP CERA	50V X7R 0.1MF K 1608	

LOC	PART CODE	PART NAME	DESCRIPTION	REMARK
CC569	HCBK102KBA	C CHIP CERA	50V X7R 1000PF K 1608	
CC570	HCBK104KBA	C CHIP CERA	50V X7R 0.1MF K 1608	
CC578	HCBK561KBA	C CHIP CERA	50V X7R 560PF K 1608	
CC579	HCBK561KBA	C CHIP CERA	50V X7R 560PF K 1608	
CC589	HCBK561KBA	C CHIP CERA	50V X7R 560PF K 1608	
CC601	HCBK472KBA	C CHIP CERA	50V X7R 4700PF K 1608	
CC602	HCBK472KBA	C CHIP CERA	50V X7R 4700PF K 1608	
CC617	HCBK104KBA	C CHIP CERA	50V X7R 0.1MF K 1608	
CC620	HCQK309CBA	C CHIP CERA	50V CH 3PF C 1608	
CC621	HCQK309CBA	C CHIP CERA	50V CH 3PF C 1608	
CC622	HCQK680JBA	C CHIP CERA	50V CH 68PF J 1608	
CC629	HCBK104KBA	C CHIP CERA	50V X7R 0.1MF K 1608	
CC631	HCBK104KBA	C CHIP CERA	50V X7R 0.1MF K 1608	
CC635	HCBK104KBA	C CHIP CERA	50V X7R 0.1MF K 1608	
CC665	HCBK222KBA	C CHIP CERA	50V X7R 2200PF K 1608	
CC667	HCBK222KBA	C CHIP CERA	50V X7R 2200PF K 1608	
CC680	HCBK102KBA	C CHIP CERA	50V X7R 1000PF K 1608	
CC701	HCBK103KBA	C CHIP CERA	50V X7R 0.01MF K 1608	
CC709	HCBK104KBA	C CHIP CERA	50V X7R 0.1MF K 1608	
CC710	HCBK104KBA	C CHIP CERA	50V X7R 0.1MF K 1608	
CC711	HCBK104KBA	C CHIP CERA	50V X7R 0.1MF K 1608	
CC712	HCQK151JBA	C CHIP CERA	50V CH 150PF J 1608	
CC713	HCBK104KBA	C CHIP CERA	50V X7R 0.1MF K 1608	
CC714	HCBK103KBA	C CHIP CERA	50V X7R 0.01MF K 1608	
CC715	HCBK104KBA	C CHIP CERA	50V X7R 0.1MF K 1608	
CC716	HCBK103KBA	C CHIP CERA	50V X7R 0.01MF K 1608	
CC722	HCBK102KBA	C CHIP CERA	50V X7R 1000PF K 1608	
CC726	HCQK330JBA	C CHIP CERA	50V CH 33PF J 1608	
CC727	HCQK330JBA	C CHIP CERA	50V CH 33PF J 1608	
CC730	HCBK104KBA	C CHIP CERA	50V X7R 0.1MF K 1608	
CC737	HCBK102KBA	C CHIP CERA	50V X7R 1000PF K 1608	
CC742	HCBK102KBA	C CHIP CERA	50V X7R 1000PF K 1608	
CC744	HCBK102KBA	C CHIP CERA	50V X7R 1000PF K 1608	
CC777	HCBK104KBA	C CHIP CERA	50V X7R 0.1MF K 1608	
IC101	14470MFLGD	IC CHIP VIDEO IF	TDA470-MFLG3	
IC501	1VSP9405C4	IC CHIP VIDEO	VSP9405C4	
IC502	1DDP3315CQ	IC CHIP	DDP3315CQ	
RC102	HRFT561JBA	R CHIP	1/10 560 OHM J 1608	
RC106	HRFT101JBA	R CHIP	1/10 100 OHM J 1608	
RC107	HRFT101JBA	R CHIP	1/10 100 OHM J 1608	
RC109	HRFT104JBA	R CHIP	1/10 100K OHM J 1608	
RC111	HRFT113JBA	R CHIP	1/10 11K OHM J 1608	
RC112	HRFT223JBA	R CHIP	1/10 22K OHM J 1608	
RC114	HRFT472JBA	R CHIP	1/10 4.7K OHM J 1608	
RC118	HRFT151JBA	R CHIP	1/10 150 OHM J 1608	
RC119	HRFT272JBA	R CHIP	1/10 2.7K OHM J 1608	
RC151	HRFT102JBA	R CHIP	1/10 1K OHM J 1608	
RC159	HRFT682JBA	R CHIP	1/10 6.8K OHM J 1608	
RC160	HRFT472JBA	R CHIP	1/10 4.7K OHM J 1608	
RC164	HRFT752JBA	R CHIP	1/10 7.5K OHM J 1608	
RC169	HRFT222JBA	R CHIP	1/10 2.2K OHM J 1608	
RC179	HRFT222JBA	R CHIP	1/10 2.2K OHM J 1608	
RC190	HRFT221JBA	R CHIP	1/10 220 OHM J 1608	
RC191	HRFT331JBA	R CHIP	1/10 330 OHM J 1608	
RC501	HRFT221JBA	R CHIP	1/10 220 OHM J 1608	
RC506	HRFT750JBA	R CHIP	1/10 75 OHM J 1608	
RC509	HRFT472JBA	R CHIP	1/10 4.7K OHM J 1608	
RC513	HRFT103JBA	R CHIP	1/10 10K OHM J 1608	
RC516	HRFT471JBA	R CHIP	1/10 470 OHM J 1608	
RC517	HRFT332JBA	R CHIP	1/10 3.3K OHM J 1608	
RC518	HRFT151JBA	R CHIP	1/10 150 OHM J 1608	
RC519	HRFT151JBA	R CHIP	1/10 150 OHM J 1608	
RC527	HRFT333JBA	R CHIP	1/10 33K OHM J 1608	
RC530	HRFT103JBA	R CHIP	1/10 10K OHM J 1608	
RC532	HRFT223JBA	R CHIP	1/10 22K OHM J 1608	
RC551	HRFT471JBA	R CHIP	1/10 470 OHM J 1608	
RC560	HRFT102JBA	R CHIP	1/10 1K OHM J 1608	
RC568	HRFT102JBA	R CHIP	1/10 1K OHM J 1608	
RC577	HRFT151JBA	R CHIP	1/10 150 OHM J 1608	
RC578	HRFT330JBA	R CHIP	1/10 33 OHM J 1608	
RC579	HRFT330JBA	R CHIP	1/10 33 OHM J 1608	

CP-850/F Service Manual

LOC	PART CODE	PART NAME	DESCRIPTION	REMARK
RC580	HRFT821JBA	R CHIP	1/10 820 OHM J 1608	
RC581	HRFT102JBA	R CHIP	1/10 1K OHM J 1608	
RC582	HRFT102JBA	R CHIP	1/10 1K OHM J 1608	
RC583	HRFT102JBA	R CHIP	1/10 1K OHM J 1608	
RC584	HRFT821JBA	R CHIP	1/10 820 OHM J 1608	
RC585	HRFT911JBA	R CHIP	1/10 910 OHM J 1608	
RC586	HRFT911JBA	R CHIP	1/10 910 OHM J 1608	
RC587	HRFT821JBA	R CHIP	1/10 820 OHM J 1608	
RC589	HRFT330JBA	R CHIP	1/10 33 OHM J 1608	
RC591	HRFT393JBA	R CHIP	1/10 39K OHM J 1608	
RC595	HRFT271JBA	R CHIP	1/10 270 OHM J 1608	
RC598	HRFT271JBA	R CHIP	1/10 270 OHM J 1608	
RC611	HRFT224JBA	R CHIP	1/10 220K OHM J 1608	
RC661	HRFT512JBA	R CHIP	1/10 5.1K OHM J 1608	
RC662	HRFT512JBA	R CHIP	1/10 5.1K OHM J 1608	
RC701	HRFT103JBA	R CHIP	1/10 10K OHM J 1608	
RC708	HRFT472JBA	R CHIP	1/10 4.7K OHM J 1608	
RC715	HRFT103JBA	R CHIP	1/10 10K OHM J 1608	
RC716	HRFT113JBA	R CHIP	1/10 11K OHM J 1608	
RC725	HRFT103JBA	R CHIP	1/10 10K OHM J 1608	
RC729	HRFT103JBA	R CHIP	1/10 10K OHM J 1608	
RC730	HRFT223JBA	R CHIP	1/10 22K OHM J 1608	
RC731	HRFT223JBA	R CHIP	1/10 22K OHM J 1608	
RC732	HRFT103JBA	R CHIP	1/10 10K OHM J 1608	
RC733	HRFT473JBA	R CHIP	1/10 47K OHM J 1608	
RC737	HRFT682JBA	R CHIP	1/10 6.8K OHM J 1608	
RC738	HRFT000-BA	R CHIP	1/10 0 OHM 1608	
RC739	HRFT000-BA	R CHIP	1/10 0 OHM 1608	
RC740	HRFT000-BA	R CHIP	1/10 0 OHM 1608	
RC741	HRFT682JBA	R CHIP	1/10 6.8K OHM J 1608	
RC742	HRFT682JBA	R CHIP	1/10 6.8K OHM J 1608	
RC743	HRFT682JBA	R CHIP	1/10 6.8K OHM J 1608	
RC750	HRFT183JBA	R CHIP	1/10 18K OHM J 1608	
RC770	HRFT332JBA	R CHIP	1/10 3.3K OHM J 1608	
RC799	HRFT472JBA	R CHIP	1/10 4.7K OHM J 1608	
RC881	HRFT103JBA	R CHIP	1/10 10K OHM J 1608	
RC882	HRFT103JBA	R CHIP	1/10 10K OHM J 1608	
ZZ200	PTMPJRT2950FS	PCB MAIN RADIAL AS	DTF-2950FZS-SB	
C102	CEXF1E470V	C ELECTRO	25V RSS 47MF (5X11) TP	
C106	CEXF1C221V	C ELECTRO	16V RSS 220MF (8X11.5) TP	
C117	CEXF1H229V	C ELECTRO	50V RSS 2.2MF (5X11) TP	
C118	CMXL1J474J	C MYLAR	63V 0.47MF MKT	
C120	CXR1H150J	C CERA	50V RH 15PF J (TAPPING)	
C121	CEXF1E470V	C ELECTRO	25V RSS 47MF (5X11) TP	
C150	CEXF1E100V	C ELECTRO	25V RSS 10MF TP	
C152	CEXF1E100V	C ELECTRO	25V RSS 10MF TP	
C153	CEXF1H229V	C ELECTRO	50V RSS 2.2MF (5X11) TP	
C157	CEXF1E100V	C ELECTRO	25V RSS 10MF TP	
C164	CEXF1E470V	C ELECTRO	25V RSS 47MF (5X11) TP	
C188	CEXF1E100V	C ELECTRO	25V RSS 10MF TP	
C301	CMXM2A224J	C MYLAR	100V 0.22MF J	
C305	CEXF1E221V	C ELECTRO	25V RSS 220MF (8X11.5) TP	
C313	CMXM2A104J	C MYLAR	100V 0.1MF J TP	
C320	CBXF1H104Z	C CERA SEMI	50V F 0.1MF Z (TAPPING)	
C340	CMXM2A683J	C MYLAR	100V 0.068MF J TP	
C350	CMXM2A223J	C MYLAR	100V 0.022MF J TP	
C351	CMXM2A223J	C MYLAR	100V 0.022MF J TP	
C370	CCXF1H473Z	C CERA	50V F 0.047MF Z (TAPPING)	
C401	CEXF1E101V	C ELECTRO	25V RSS 100MF (6.3X11) TP	
C410	CCXB2H681K	C CERA	500V B 680PF K (TAPPING)	
C416	CCXB2H471K	C CERA	500V B 470PF K (TAPPING)	
C417	CMXM2A392J	C MYLAR	100V 3900PF J TP	
C420	CMXM2A273J	C MYLAR	100V 0.027MF J TP	
C424	CMXM2A333J	C MYLAR	100V 0.033MF J TP	
C425	CCXB1H472K	C CERA	50V B 4700PF K (TAPPING)	
C501	CEXF1E100V	C ELECTRO	25V RSS 10MF TP	
C502	CEXF1E100V	C ELECTRO	25V RSS 10MF TP	
C503	CEXF1E100V	C ELECTRO	25V RSS 10MF TP	
C504	CEXF1E100V	C ELECTRO	25V RSS 10MF TP	
C505	CEXF1E100V	C ELECTRO	25V RSS 10MF TP	
C506	CEXF1E100V	C ELECTRO	25V RSS 10MF TP	

LOC	PART CODE	PART NAME	DESCRIPTION	REMARK
C524	CEXF1E470V	C ELECTRO	25V RSS 47MF (5X11) TP	
C530	CEXF1E100V	C ELECTRO	25V RSS 10MF TP	
C550	CEXF1E100V	C ELECTRO	25V RSS 10MF TP	
C551	CEXF1E100V	C ELECTRO	25V RSS 10MF TP	
C560	CEXF1E101V	C ELECTRO	25V RSS 100MF (6.3X11) TP	
C561	CEXF1H339V	C ELECTRO	50V RSS 3.3MF (5X11) TP	
C568	CEXF1E101V	C ELECTRO	25V RSS 100MF (6.3X11) TP	
C590	CEXF1H479V	C ELECTRO	50V RSS 4.7MF (5*11) TP	
C602	CEXF1E101V	C ELECTRO	25V RSS 100MF (6.3X11) TP	
C605	CEXF1E470V	C ELECTRO	25V RSS 47MF (5X11) TP	
C608	CEXF1E100V	C ELECTRO	25V RSS 10MF TP	
C610	CEXF1E100V	C ELECTRO	25V RSS 10MF TP	
C611	CEXF1H339V	C ELECTRO	50V RSS 3.3MF (5X11) TP	
C612	CEXF1H109V	C ELECTRO	50V RSS 1MF (5X11) TP	
C613	CEXF1H109V	C ELECTRO	50V RSS 1MF (5X11) TP	
C614	CEXF1H109V	C ELECTRO	50V RSS 1MF (5X11) TP	
C615	CEXF1H109V	C ELECTRO	50V RSS 1MF (5X11) TP	
C616	CEXF1E100V	C ELECTRO	25V RSS 10MF TP	
C623	CEXF1H109V	C ELECTRO	50V RSS 1MF (5X11) TP	
C624	CEXF1H109V	C ELECTRO	50V RSS 1MF (5X11) TP	
C625	CEXF1E101V	C ELECTRO	25V RSS 100MF (6.3X11) TP	
C626	CEXF1E101V	C ELECTRO	25V RSS 100MF (6.3X11) TP	
C627	CEXF1H479V	C ELECTRO	50V RSS 4.7MF (5*11) TP	
C630	CEXF1E470V	C ELECTRO	25V RSS 47MF (5X11) TP	
C634	CEXF1E100V	C ELECTRO	25V RSS 10MF TP	
C636	CEXF1E470V	C ELECTRO	25V RSS 47MF (5X11) TP	
C641	CEXF1E101V	C ELECTRO	25V RSS 100MF (6.3X11) TP	
C642	CEXF1E101V	C ELECTRO	25V RSS 100MF (6.3X11) TP	
C660	CEXF1E100V	C ELECTRO	25V RSS 10MF TP	
C661	CMXM2A224J	C MYLAR	100V 0.22MF J	
C662	CMXM2A224J	C MYLAR	100V 0.22MF J	
C666	CBXF1H104Z	C CERA SEMI	50V F 0.1MF Z (TAPPING)	
C668	CMXM2A224J	C MYLAR	100V 0.22MF J	
C669	CMXM2A224J	C MYLAR	100V 0.22MF J	
C709	CEXF1E101V	C ELECTRO	25V RSS 100MF (6.3X11) TP	
C711	CEXF1E101V	C ELECTRO	25V RSS 100MF (6.3X11) TP	
C713	CEXF1E100V	C ELECTRO	25V RSS 10MF TP	
C730	CEXF1E100V	C ELECTRO	25V RSS 10MF TP	
C733	CEXF1H229V	C ELECTRO	50V RSS 2.2MF (5X11) TP	
C737	CEXF1E100V	C ELECTRO	25V RSS 10MF TP	
C742	CEXF1E100V	C ELECTRO	25V RSS 10MF TP	
C744	CEXF1E100V	C ELECTRO	25V RSS 10MF TP	
C803	CCXF3A472Z	C CERA	1KV F 4700PF Z (T)	
C804	CCXF3A472Z	C CERA	1KV F 4700PF Z (T)	
C806	CCXR3A102K	C CERA	1KV R 1000PF (T) 125C	
C807	CEXF1H109V	C ELECTRO	50V RSS 1MF (5X11) TP	
C810	CEXF1H100V	C ELECTRO	50V RSS 10MF (5X11) TP	
C811	CMXM2A473J	C MYLAR	100V 0.047MF J TP	
C830	CEXF1H479V	C ELECTRO	50V RSS 4.7MF (5*11) TP	
C831	CEXF1H109V	C ELECTRO	50V RSS 1MF (5X11) TP	
C833	CCXB1H821K	C CERA	50V B 820PF K (TAPPING)	
C835	CEXF1E470V	C ELECTRO	25V RSS 47MF (5X11) TP	
C845	CEXF1E101V	C ELECTRO	25V RSS 100MF (6.3X11) TP	
C846	CEXF1E101V	C ELECTRO	25V RSS 100MF (6.3X11) TP	
C847	CEXF1H100V	C ELECTRO	50V RSS 10MF (5X11) TP	
C850	CEXF1H100V	C ELECTRO	50V RSS 10MF (5X11) TP	
C853	CCXF3A472Z	C CERA	1KV F 4700PF Z (T)	
C854	CCXF3A472Z	C CERA	1KV F 4700PF Z (T)	
C863	CEXF1E101V	C ELECTRO	25V RSS 100MF (6.3X11) TP	
C864	CEXF1H100V	C ELECTRO	50V RSS 10MF (5X11) TP	
C865	CEXF1H100V	C ELECTRO	50V RSS 10MF (5X11) TP	
C866	CCXR3A471K	C CERA	1KV R 470PF K 125C	
C871	CEXF1C471V	C ELECTRO	16V RSS 470MF (10X12.5)TP	
C880	CEXF1E101V	C ELECTRO	25V RSS 100MF (6.3X11) TP	
C888	CEXF1E220V	C ELECTRO	25V RSS 22MF TP	
CP05	CEXF1H100V	C ELECTRO	50V RSS 10MF (5X11) TP	
CP06	CCXB3A102K	C CERA	1KV B 1000PF K (TAPPING)	
I704	1K1A7025AP	IC RESET	KIA7025AP	
L101	5CPX479K—	COIL PEAKING	4.7UH K RADIAL	
L380	58C0000116	COIL BEAD	HC-3550R	
L381	58C0000116	COIL BEAD	HC-3550R	

LOC	PART CODE	PART NAME	DESCRIPTION	REMARK
L802	58CX430599	COIL CHOKE	AZ-9004Y 940K TP	
Q103	T2SC5343Y-	TR	2SC5343Y	
Q104	T2SC5343Y-	TR	2SC5343Y	
Q110	T2SC5343Y-	TR	2SC5343Y	
Q150	T2SC5343Y-	TR	2SC5343Y	
Q151	T2SC5343Y-	TR	2SC5343Y	
Q333	T2SC5343Y-	TR	2SC5343Y	
Q334	T2SC5343Y-	TR	2SC5343Y	
Q402	T2SD1207T-	TR	2SD1207-T (TAPPING)	
Q502	T2SC5343Y-	TR	2SC5343Y	
Q503	T2SC5343Y-	TR	2SC5343Y	
Q504	T2SA1980Y-	TR	2SA1980Y	
Q542	T2SA1980Y-	TR	2SA1980Y	
Q543	T2SA1980Y-	TR	2SA1980Y	
Q544	T2SA1980Y-	TR	2SA1980Y	
Q550	T2SC5343Y-	TR	2SC5343Y	
Q601	T2SA1980Y-	TR	2SA1980Y	
Q602	T2SC5343Y-	TR	2SC5343Y	
Q603	T2SA1980Y-	TR	2SA1980Y	
Q604	T2SC5343Y-	TR	2SC5343Y	
Q605	T2SC5343Y-	TR	2SC5343Y	
Q730	T2SC5343Y-	TR	2SC5343Y	
Q731	T2SC5343Y-	TR	2SC5343Y	
Q809	T2SC5343Y-	TR	2SC5343Y	
Q810	T2SC5343Y-	TR	2SC5343Y	
Q812	TKTC3203Y-	TR	KTC3203-Y	
QP01	T2SD1207T-	TR	2SD1207-T (TAPPING)	
QP02	T2SC5343Y-	TR	2SC5343Y	
R331	RN02B681JS	R METAL FILM	2W 680 OHM J SMALL	
R332	RN02B681JS	R METAL FILM	2W 680 OHM J SMALL	
R401	RN02B360JS	R METAL FILM	2W 36 OHM J SMALL	
R402	RN02B360JS	R METAL FILM	2W 36 OHM J SMALL	
R410	RN02B473JS	R METAL FILM	2W 47K OHM J SMALL	
R415	RN02B561JS	R METAL FILM	2W 560 OHM J SMALL	
RP04	RN02B753JS	R METAL FILM	2W 75K OHM J SMALL	
RP05	RN02B333JS	R METAL FILM	2W 33K OHM J SMALL	
RP14	RN01B124JS	R METAL FILM	1W 120K OHM J SMALL	
X502	5XEX5R000E	CRYSTAL QUARTZ	HC-49/U 6.000MHZ 30PPM	
X701	5XEX6R000C	CRYSTAL QUARTZ	HC-49/U 6.000M 20PPM TP	
Z601	5PXF1B471M	FILTER EMI	CFI 06 B 1H 470PF	
Z602	5PXF1B471M	FILTER EMI	CFI 06 B 1H 470PF	
Z603	5PXF1B471M	FILTER EMI	CFI 06 B 1H 470PF	
Z604	5PXF1B471M	FILTER EMI	CFI 06 B 1H 470PF	
Z605	5PXF1B471M	FILTER EMI	CFI 06 B 1H 470PF	
Z606	5PXF1B471M	FILTER EMI	CFI 06 B 1H 470PF	
Z607	5PXF1B471M	FILTER EMI	CFI 06 B 1H 470PF	
Z608	5PXF1B471M	FILTER EMI	CFI 06 B 1H 470PF	
ZZ200	PTMPJAT2950FS	PCB MAIN AXIAL AS	DTF-2950FZS-SB	
10	2TM14006LB	TAPE MASKING	3M #232 6.0X2000M (WITH GLUE)	
20	2TM10006LB	TAPE MASKING	3M #232-MAP-C 6.2X2000M (W/O GLUE)	
A001	4859812993	PCB MAIN	CP-850FX DTF-2950 (330X246 D1B)	°
C101	CCZB1H101K	C CERA	50V B 100PF K (AXIAL)	
C111	CCZB1H103K	C CERA	50V B 0.01MF K (AXIAL)	
C112	CCZB1H102K	C CERA	50V B 1000PF K (AXIAL)	
C161	CZCH1H220J	C CERA	50V CH 22PF J (AXIAL)	
C414	CCZB1H103K	C CERA	50V B 0.01MF K (AXIAL)	
C440	CCZB1H221K	C CERA	50V B 220PF K (AXIAL)	
C508	CCZB1H473K	C CERA	50V B 0.047MF K (AXIAL)	
C509	CCZB1H473K	C CERA	50V B 0.047MF K (AXIAL)	
C510	CCZB1H473K	C CERA	50V B 0.047MF K (AXIAL)	
C515	CBZF1H104Z	C CERA SEMI	50V F 0.1MF Z (AXIAL)	
C516	CBZF1H104Z	C CERA SEMI	50V F 0.1MF Z (AXIAL)	
C517	CBZF1H104Z	C CERA SEMI	50V F 0.1MF Z (AXIAL)	
C518	CBZF1H104Z	C CERA SEMI	50V F 0.1MF Z (AXIAL)	
C519	CBZF1H104Z	C CERA SEMI	50V F 0.1MF Z (AXIAL)	
C532	CCZB1H103K	C CERA	50V B 0.01MF K (AXIAL)	
C534	CCZB1H103K	C CERA	50V B 0.01MF K (AXIAL)	
C536	CCZB1H102K	C CERA	50V B 1000PF K (AXIAL)	
C537	CCZB1H103K	C CERA	50V B 0.01MF K (AXIAL)	
C538	CCZB1H103K	C CERA	50V B 0.01MF K (AXIAL)	
C540	CCZB1H333K	C CERA	50V B 0.033MF K (AXIAL)	

LOC	PART CODE	PART NAME	DESCRIPTION	REMARK
C553	CCZB1H103K	C CERA	50V B 0.01MF K (AXIAL)	
C557	CBZF1H104Z	C CERA SEMI	50V F 0.1MF Z (AXIAL)	
C558	CBZF1H104Z	C CERA SEMI	50V F 0.1MF Z (AXIAL)	
C650	CZSL1H680J	C CERA	50V SL 68PF J (AXIAL)	
C712	CBZF1H104Z	C CERA SEMI	50V F 0.1MF Z (AXIAL)	
C809	CCZB1H102K	C CERA	50V B 1000PF K (AXIAL)	
C834	CCZF1H103Z	C CERA	50V F 0.01MF Z	
D100	DTZX33B—	DIODE ZENER	TZX33B (TAPPING)	
D101	DBAT85—	DIODE	BAT85 (TAPPING)	
D103	DBA282—	DIODE	BA282	
D313	DRGP15J—	DIODE	RG15J	
D367	DTZX33B—	DIODE ZENER	TZX33B (TAPPING)	
D405	D1N4937G—	DIODE	1N4937G	
D408	D1N4937G—	DIODE	1N4937G	
D410	D1N4937G—	DIODE	1N4937G	
D414	D1N4004S—	DIODE	1N4004S	
D415	D1N4937G—	DIODE	1N4937G	
D530	D1N4148—	DIODE	1N4148 (TAPPING)	
D531	D1N4148—	DIODE	1N4148 (TAPPING)	
D535	D1N4148—	DIODE	1N4148 (TAPPING)	
D540	D1N4148—	DIODE	1N4148 (TAPPING)	
D541	D1N4148—	DIODE	1N4148 (TAPPING)	
D550	D1N4148—	DIODE	1N4148 (TAPPING)	
D551	D1N4148—	DIODE	1N4148 (TAPPING)	
D602	D1N4148—	DIODE	1N4148 (TAPPING)	
D603	D1N4148—	DIODE	1N4148 (TAPPING)	
D701	D1N4148—	DIODE	1N4148 (TAPPING)	
D702	D1N4148—	DIODE	1N4148 (TAPPING)	
D720	DTZX2V7A—	DIODE ZENER	TZX2V7A (TAPPING)	
D730	DTZX7V5C—	DIODE ZENER	TZX7V5C (TAPPING)	
D777	DTZX5V6B—	DIODE ZENER	TZX5V6B (TAPPING)	
D801	DLT2A05G—	DIODE	LT2A05G	
D802	DLT2A05G—	DIODE	LT2A05G	
D803	DLT2A05G—	DIODE	LT2A05G	
D804	DLT2A05G—	DIODE	LT2A05G	
D805	D1N4148—	DIODE	1N4148 (TAPPING)	
D806	D1N4937G—	DIODE	1N4937G	
D807	D1N4937G—	DIODE	1N4937G	
D808	DTZX6V2—	DIODE ZENER	TZX6V2B (TAPPING)	
D811	DTZX7V5C—	DIODE ZENER	TZX7V5C (TAPPING)	
D825	D1N4148—	DIODE	1N4148 (TAPPING)	
D826	DTZX5V1B—	DIODE ZENER	TZX5V1B (TAPPING)	
D827	D1N4004S—	DIODE	1N4004S	
D830	DRGP15J—	DIODE	RG15J	
D831	DRGP15J—	DIODE	RG15J	
D871	D1N4937G—	DIODE	1N4937G	
D899	DRGP15J—	DIODE	RG15J	
DA11	DTZX5V6B—	DIODE ZENER	TZX5V6B (TAPPING)	
DA13	DTZX5V6B—	DIODE ZENER	TZX5V6B (TAPPING)	
DA16	DTZX5V6B—	DIODE ZENER	TZX5V6B (TAPPING)	
DA17	DTZX5V6B—	DIODE ZENER	TZX5V6B (TAPPING)	
DA27	DTZX5V6B—	DIODE ZENER	TZX5V6B (TAPPING)	
DP02	D1N4148—	DIODE	1N4148 (TAPPING)	
DP03	D1N4148—	DIODE	1N4148 (TAPPING)	
DP04	DTZX12C—	DIODE ZENER	TZX12C (TAPPING)	
DP05	DTZX8V2A—	DIODE ZENER	TZX8V2A (TAPPING)	
DP06	D1N4148—	DIODE	1N4148 (TAPPING)	
DP08	D1N4148—	DIODE	1N4148 (TAPPING)	
J1	85801060GY	WIRE COPPER	1/0.6 TIN COATING	
J112	85801060GY	WIRE COPPER	1/0.6 TIN COATING	
J113	85801060GY	WIRE COPPER	1/0.6 TIN COATING	
J114	85801060GY	WIRE COPPER	1/0.6 TIN COATING	
J115	85801060GY	WIRE COPPER	1/0.6 TIN COATING	
J125	85801060GY	WIRE COPPER	1/0.6 TIN COATING	
J128	85801060GY	WIRE COPPER	1/0.6 TIN COATING	
J135	85801060GY	WIRE COPPER	1/0.6 TIN COATING	
J143	85801060GY	WIRE COPPER	1/0.6 TIN COATING	
J156	85801060GY	WIRE COPPER	1/0.6 TIN COATING	
J2	85801060GY	WIRE COPPER	1/0.6 TIN COATING	
J201	85801060GY	WIRE COPPER	1/0.6 TIN COATING	
J232	85801060GY	WIRE COPPER	1/0.6 TIN COATING	

LOC	PART CODE	PART NAME	DESCRIPTION	REMARK
J63	85801060GY	WIRE COPPER	1/0.6 TIN COATING	
L105	5CPZ479K02	COIL PEAKING	4.7UH 3.5MM K (LAL02TB)	
L153	5CPZ120K02	COIL PEAKING	12UH 3.5MM K (LAL02TB)	
L402	85801060GY	WIRE COPPER	1/0.6 TIN COATING	
L501	5CPZ479K04	COIL PEAKING	4.7UH 10.5MM K (LAL04TB)	
L502	5CPZ479K04	COIL PEAKING	4.7UH 10.5MM K (LAL04TB)	
L506	5CPZ479K04	COIL PEAKING	4.7UH 10.5MM K (LAL04TB)	
L507	5CPZ100K04	COIL PEAKING	10UH 10.5MM K (LAL04TB)	
L524	5CPZ100K02	COIL PEAKING	10UH 3.5MM K (LAL02TB)	
L551	5CPZ479K04	COIL PEAKING	4.7UH 10.5MM K (LAL04TB)	
L568	5CPZ100K02	COIL PEAKING	10UH 3.5MM K (LAL02TB)	
L601	5CPZ479K02	COIL PEAKING	4.7UH 3.5MM K (LAL02TB)	
L602	5CPZ100K02	COIL PEAKING	10UH 3.5MM K (LAL02TB)	
L603	5CPZ479K02	COIL PEAKING	4.7UH 3.5MM K (LAL02TB)	
L605	5CPZ479K02	COIL PEAKING	4.7UH 3.5MM K (LAL02TB)	
L650	5MC0000100	COIL BEAD	MD-5 (HC-3550)	
L709	5CPZ100K02	COIL PEAKING	10UH 3.5MM K (LAL02TB)	
L711	5CPZ100K02	COIL PEAKING	10UH 3.5MM K (LAL02TB)	
L713	5CPZ100K02	COIL PEAKING	10UH 3.5MM K (LAL02TB)	
L730	5CPZ100K02	COIL PEAKING	10UH 3.5MM K (LAL02TB)	
L737	5CPZ100K02	COIL PEAKING	10UH 3.5MM K (LAL02TB)	
L742	5CPZ100K02	COIL PEAKING	10UH 3.5MM K (LAL02TB)	
L744	5CPZ100K02	COIL PEAKING	10UH 3.5MM K (LAL02TB)	
L801	5MC0000100	COIL BEAD	MD-5 (HC-3550)	
R103	RD-AZ123J	R CARBON FILM	1/6 12K OHM J	
R110	RN-4Z1502F	R METAL FILM	1/4 15K OHM F	
R150	RD-AZ561J	R CARBON FILM	1/6 560 OHM J	
R152	RD-AZ271J	R CARBON FILM	1/6 270 OHM J	
R153	RD-AZ470J	R CARBON FILM	1/6 47 OHM J	
R154	RD-AZ470J	R CARBON FILM	1/6 47 OHM J	
R155	RD-AZ751J	R CARBON FILM	1/6 750 OHM J	
R161	RD-AZ102J	R CARBON FILM	1/6 1K OHM J	
R162	RD-AZ153J	R CARBON FILM	1/6 15K OHM J	
R163	RD-AZ752J	R CARBON FILM	1/6 7.5K OHM J	
R177	RD-AZ562J	R CARBON FILM	1/6 5.6K OHM J	
R301	RD-4Z472J	R CARBON FILM	1/4 4.7K OHM J	
R310	RD-AZ432J	R CARBON FILM	1/6 4.3K OHM J	
R311	RD-AZ432J	R CARBON FILM	1/6 4.3K OHM J	
R333	RD-AZ222J	R CARBON FILM	1/6 2.2K OHM J	
R334	RD-AZ222J	R CARBON FILM	1/6 2.2K OHM J	
R340	85801060GY	WIRE COPPER	1/0.6 TIN COATING	
R341	85801060GY	WIRE COPPER	1/0.6 TIN COATING	
R345	RD-4Z473J	R CARBON FILM	1/4 47K OHM J	
R350	RN-AZ2201F	R METAL FILM	1/6 2.2K OHM F	
R351	RN-AZ2201F	R METAL FILM	1/6 2.2K OHM F	
R370	RD-4Z159J	R CARBON FILM	1/4 1.5 OHM J	
R394	RD-AZ272J	R CARBON FILM	1/6 2.7K OHM J	
R395	RD-4Z754J	R CARBON FILM	1/4 750K OHM J	
R396	RD-AZ272J	R CARBON FILM	1/6 2.7K OHM J	
R397	RD-AZ104J	R CARBON FILM	1/6 100K OHM J	
R414	RD-AZ681J	R CARBON FILM	1/6 680 OHM J	
R420	RD-AZ471J	R CARBON FILM	1/6 47 OHM J	
R424	RD-4Z472J	R CARBON FILM	1/4 4.7K OHM J	
R430	RD-4Z103J	R CARBON FILM	1/4 10K OHM J	
R440	RD-4Z274J	R CARBON FILM	1/4 270K OHM J	
R501	RD-AZ101J	R CARBON FILM	1/6 100 OHM J	
R502	RD-AZ101J	R CARBON FILM	1/6 100 OHM J	
R504	RD-AZ102J	R CARBON FILM	1/6 1K OHM J	
R507	RD-AZ562J	R CARBON FILM	1/6 5.6K OHM J	
R510	RD-AZ101J	R CARBON FILM	1/6 100 OHM J	
R511	RD-AZ330J	R CARBON FILM	1/6 33 OHM J	
R512	RD-AZ330J	R CARBON FILM	1/6 33 OHM J	
R513	RD-AZ330J	R CARBON FILM	1/6 33 OHM J	
R514	RD-AZ151J	R CARBON FILM	1/6 150 OHM J	
R515	RD-AZ223J	R CARBON FILM	1/6 22K OHM J	
R516	RD-AZ752J	R CARBON FILM	1/6 7.5K OHM J	
R517	RD-AZ471J	R CARBON FILM	1/6 47 OHM J	
R518	RD-AZ750J	R CARBON FILM	1/6 75 OHM J	

LOC	PART CODE	PART NAME	DESCRIPTION	REMARK
R519	RD-AZ750J	R CARBON FILM	1/6 75 OHM J	
R520	RD-AZ750J	R CARBON FILM	1/6 75 OHM J	
R524	RD-AZ391J	R CARBON FILM	1/6 390 OHM J	
R525	RD-AZ101J	R CARBON FILM	1/6 100 OHM J	
R533	RD-AZ392J	R CARBON FILM	1/6 3.9K OHM J	
R534	RD-AZ391J	R CARBON FILM	1/6 390 OHM J	
R535	RD-AZ122J	R CARBON FILM	1/6 1.2K OHM J	
R537	RD-AZ301J	R CARBON FILM	1/6 300 OHM J	
R538	RD-AZ301J	R CARBON FILM	1/6 300 OHM J	
R540	RD-AZ472J	R CARBON FILM	1/6 4.7K OHM J	
R545	RD-AZ750J	R CARBON FILM	1/6 75 OHM J	
R550	RD-AZ102J	R CARBON FILM	1/6 1K OHM J	
R551	RD-AZ471J	R CARBON FILM	1/6 470 OHM J	
R563	RD-AZ101J	R CARBON FILM	1/6 100 OHM J	
R564	RD-AZ101J	R CARBON FILM	1/6 100 OHM J	
R566	RD-AZ220J	R CARBON FILM	1/6 22 OHM J	
R570	RD-AZ271J	R CARBON FILM	1/6 270 OHM J	
R576	RD-AZ151J	R CARBON FILM	1/6 150 OHM J	
R580	RD-AZ101J	R CARBON FILM	1/6 100 OHM J	
R588	RD-AZ101J	R CARBON FILM	1/6 100 OHM J	
R590	RD-AZ102J	R CARBON FILM	1/6 1K OHM J	
R593	RD-AZ203J	R CARBON FILM	1/6 20K OHM J	
R594	RD-AZ101J	R CARBON FILM	1/6 100 OHM J	
R595	RD-AZ101J	R CARBON FILM	1/6 100 OHM J	
R599	RD-AZ151J	R CARBON FILM	1/6 150 OHM J	
R602	RD-AZ104J	R CARBON FILM	1/6 100K OHM J	
R605	RD-AZ101J	R CARBON FILM	1/6 100 OHM J	
R606	RD-AZ101J	R CARBON FILM	1/6 100 OHM J	
R610	RD-AZ682J	R CARBON FILM	1/6 6.8K OHM J	
R612	RD-AZ474J	R CARBON FILM	1/6 470K OHM J	
R613	RD-AZ473J	R CARBON FILM	1/6 47K OHM J	
R614	RD-AZ102J	R CARBON FILM	1/6 1K OHM J	
R615	RD-AZ102J	R CARBON FILM	1/6 1K OHM J	
R616	RD-AZ103J	R CARBON FILM	1/6 10K OHM J	
R620	RD-AZ242J	R CARBON FILM	1/6 2.4K OHM J	
R621	RD-AZ102J	R CARBON FILM	1/6 1K OHM J	
R622	RD-AZ102J	R CARBON FILM	1/6 1K OHM J	
R641	RD-AZ102J	R CARBON FILM	1/6 1K OHM J	
R642	RD-AZ102J	R CARBON FILM	1/6 1K OHM J	
R646	RD-AZ102J	R CARBON FILM	1/6 1K OHM J	
R647	RD-AZ102J	R CARBON FILM	1/6 1K OHM J	
R649	RD-AZ102J	R CARBON FILM	1/6 1K OHM J	
R650	RD-AZ362J	R CARBON FILM	1/6 3.6K OHM J	
R651	RD-AZ102J	R CARBON FILM	1/6 1K OHM J	
R652	RD-AZ102J	R CARBON FILM	1/6 1K OHM J	
R660	RD-AZ362J	R CARBON FILM	1/6 3.6K OHM J	
R680	RD-AZ152J	R CARBON FILM	1/6 1.5K OHM J	
R700	RD-2Z332J	R CARBON FILM	1/2 3.3K OHM J	
R701	RD-AZ472J	R CARBON FILM	1/6 4.7K OHM J	
R702	RD-AZ102J	R CARBON FILM	1/6 1K OHM J	
R703	RD-AZ101J	R CARBON FILM	1/6 100 OHM J	
R704	RD-AZ101J	R CARBON FILM	1/6 100 OHM J	
R709	RD-AZ472J	R CARBON FILM	1/6 4.7K OHM J	
R720	RD-AZ681J	R CARBON FILM	1/6 680 OHM J	
R741	RD-AZ101J	R CARBON FILM	1/6 100 OHM J	
R748	RD-AZ101J	R CARBON FILM	1/6 100 OHM J	
R777	RD-AZ750J	R CARBON FILM	1/6 75 OHM J	
R781	RD-AZ332J	R CARBON FILM	1/6 3.3K OHM J	
R788	RD-AZ103J	R CARBON FILM	1/6 10K OHM J	
R789	RD-AZ103J	R CARBON FILM	1/6 10K OHM J	
R790	RD-AZ512J	R CARBON FILM	1/6 5.1K OHM J	
R804	RD-4Z479J	R CARBON FILM	1/4 4.7 OHM J	
R805	RD-2Z104J	R CARBON FILM	1/2 100K OHM J	
R807	RD-4Z221J	R CARBON FILM	1/4 220 OHM J	
R808	RD-4Z182J	R CARBON FILM	1/4 1.8K OHM J	
R809	RD-4Z102J	R CARBON FILM	1/4 1K OHM J	
R810	RD-4Z220J	R CARBON FILM	1/4 22 OHM J	

CP-850FX Service Manual

LOC	PART CODE	PART NAME	DESCRIPTION	REMARK
R811	RC-2Z565KP	R CARBON COMP	1/2 5.6M OHM K	△
R817	RD-AZ473J	R CARBON FILM	1/6 47K OHM J	
R818	RD-AZ683J	R CARBON FILM	1/6 68K OHM J	
R820	RD-4Z363J	R CARBON FILM	1/4 36K OHM J	
R821	RD-AZ563J	R CARBON FILM	1/6 56K OHM J	
R823	RD-4Z332J	R CARBON FILM	1/4 3.3K OHM J	
R827	RD-AZ103J	R CARBON FILM	1/6 10K OHM J	
R828	RD-4Z153J	R CARBON FILM	1/4 15K OHM J	
R829	RD-AZ103J	R CARBON FILM	1/6 10K OHM J	
R830	RD-AZ101J	R CARBON FILM	1/6 100 OHM J	
R831	RD-AZ472J	R CARBON FILM	1/6 4.7K OHM J	
R832	RD-AZ473J	R CARBON FILM	1/6 47K OHM J	
R834	RD-4Z470J	R CARBON FILM	1/4 47 OHM J	
R870	RD-4Z102J	R CARBON FILM	1/4 1K OHM J	
R883	RD-AZ103J	R CARBON FILM	1/6 10K OHM J	
R884	RD-AZ103J	R CARBON FILM	1/6 10K OHM J	
RA01	RD-AZ220J	R CARBON FILM	1/6 22 OHM J	
RA10	RD-AZ103J	R CARBON FILM	1/6 10K OHM J	
RA13	RD-AZ332J	R CARBON FILM	1/6 3.3K OHM J	
RA15	RD-AZ680J	R CARBON FILM	1/6 68 OHM J	
RA16	RD-AZ750J	R CARBON FILM	1/6 75 OHM J	
RA32	85801060GY	WIRE COPPER	1/0.6 TIN COATING	
RA35	RD-AZ750J	R CARBON FILM	1/6 75 OHM J	
RA88	RD-AZ750J	R CARBON FILM	1/6 75 OHM J	
RP03	RD-4Z102J	R CARBON FILM	1/4 1K OHM J	
RP06	RD-4Z472J	R CARBON FILM	1/4 4.7K OHM J	
RP08	RD-4Z361J	R CARBON FILM	1/4 360 OHM J	
RP10	RD-2Z472J	R CARBON FILM	1/2 4.7K OHM J	
RP12	RD-4Z470J	R CARBON FILM	1/4 47 OHM J	
RP13	RD-2Z101J	R CARBON FILM	1/2 100 OHM J	
ZZ400	PTCPMST2950FS	PCB CRT MANUAL AS	DTF-2950FZS-SB	
C900	CCXB3D102K	C CERA	2KV B 1000 PF K (TAPPING)	
C910	CEXF2E479V	C ELECTRO	250V RSS 4.7MF (10X16)TP	
C997	CEXF2E100V	C ELECTRO	250V RSS 10MF (10X20) TP	
I901	1TDA6108JF	IC VIDEO	TD46108JF	
I901A	4857025401	HEAT SINK	A1050P-H24 T2	
I901B	7174300851	SCREW TAPPTITE	TT2 RND 3X8 MFZN 3CR	
P401A	4859231820	CONN WAFER	YW025-05	
P501A	4859235120	CONN WAFER	YW025-08	
P903	4859238620	CONN WAFER	YPW500-02	
R906	RF02Y629J	R FUSIBLE	2W 6.2 OHM J	
SCT1	4859304130	SOCKET CRT	ISHG93S	△
ZZ200	PTCPJRT2950FS	PCB CRT RADIAL AS	DTF-2950FZS-SB	
C902	CMXL2E104K	C MYLAR	250V 0.1MF K MEU TP	
C921	CMXM2A102J	C MYLAR	100V 1000PF J TP	
C922	CMXM2A102J	C MYLAR	100V 1000PF J TP	
C923	CMXM2A102J	C MYLAR	100V 1000PF J TP	
G900	4SG0DX0001	SPARK GAP	SSG-102-A1 (1.0KV)	
G901	4SG0DX0001	SPARK GAP	SSG-102-A1 (1.0KV)	
G902	4SG0DX0001	SPARK GAP	SSG-102-A1 (1.0KV)	
G903	4SG0DX0001	SPARK GAP	SSG-102-A1 (1.0KV)	
Q921	TBF423—	TR	BF423 TO-92	
Q922	TBF423—	TR	BF423 TO-92	
Q923	TBF423—	TR	BF423 TO-92	
R905	RN02B102JS	R METAL FILM	2W 1K OHM J SMALL	
ZZ200	PTCPJAT2950FS	PCB CRT AXIAL AS	DTF-2950FZS-SB	
A001	4859829013	PCB CRT	CP-830/830F (DTG/DTH)	△
D911	D1N4004S—	DIODE	1N4004S	
D912	D1N4004S—	DIODE	1N4004S	
D913	D1N4004S—	DIODE	1N4004S	
D921	D1N4004S—	DIODE	1N4004S	
D922	D1N4004S—	DIODE	1N4004S	
D923	D1N4004S—	DIODE	1N4004S	
D997	DLT2A05G—	DIODE	LT2A05G	
R901	RD-AZ101J	R CARBON FILM	1/6 100 OHM J	
R902	RD-AZ101J	R CARBON FILM	1/6 100 OHM J	

LOC	PART CODE	PART NAME	DESCRIPTION	REMARK
R903	RD-AZ101J	R CARBON FILM	1/6 100 OHM J	
R911	RD-AZ101J	R CARBON FILM	1/6 100 OHM J	
R912	RD-AZ101J	R CARBON FILM	1/6 100 OHM J	
R913	RD-AZ101J	R CARBON FILM	1/6 100 OHM J	
R921	RC-2Z102K-	R CARBON COMP	1/2 1K OHM K	
R922	RC-2Z102K-	R CARBON COMP	1/2 1K OHM K	
R923	RC-2Z102K-	R CARBON COMP	1/2 1K OHM K	
R931	RD-AZ102J	R CARBON FILM	1/6 1K OHM J	
R932	RD-AZ102J	R CARBON FILM	1/6 1K OHM J	
R933	RD-AZ102J	R CARBON FILM	1/6 1K OHM J	
R996	RD-2Z105J	R CARBON FILM	1/2 1M OHM J	
R997	RD-2Z102J	R CARBON FILM	1/2 1K OHM J	
ZZ140	PTPKCPT2950F	PACKING AS	DTF-2950FZF-SB	
10	6520010200	STAPLE PIN	#3417 ALL	
M681	2TP06575CL	TAPE OPP	T0.065XW75X500M CLEAR	
M801	DMP5018800	BOX	DTL-2950 (NEW)	
M811	485819C900DN	PAD DOWN	2950 EPS	
M811A	485819C900UP	PAD UP	2950 EPS	
M821	4858215601	BAG P.E.	"PE FOAM TO.5X1600X1270 25"-28"	

CP-850/F Service Manual

6.2 DTF-2930

LOC	PART CODE	PART NAME	DESCRIPTION	REMARK
LOC	PART CODE	PART NAME	DESCRIPTION	REMARK
ZZ100	PTACPWT2950F	ACCESSORY AS	DTF-2950FZF-SB	
12000	48B5849C1001	TRANSMITTER REMOCON	R-49C10	
13000	4850Q00910	BATTERY	AAA R03 SUPERGARD/ROCKET	
14000	4858213801	BAG INSTRUCTION	L. D. P. E. TO. 05X250X400	
ZZ120	PTBCSHL2950S	COVER BACK AS	DTL-2950FZF-S	
M211	4852174911	COVER BACK	2950 HIPS GY8301A	
M211D	4857817610	CLOTH BLACK	"300 MM 20"	
M541	4855415800	S/PLATE	150ART P/E FILM (C/TV)	
M542	4855800022P1	LABEL SERIAL	ART 90 55X34	
ZZ130	PTCACAF2930FSS	CABINET AS	DTF-2930FZS-SB	
M201A	4856017752	SCREW CRT FIX	6X35 L120 YL 3CR	
M201B	4856219502	WASHER RUBBER	CR T2.0 BLACK	
M201C	7178301051	SCREW TAPPTITE	TT2 WAS 3X10 MFZN 3CR	
M201D	4856017800	SCREW SPKR FIX	SWRM+SECC 3CR	
M201E	7178301051	SCREW TAPPTITE	TT2 WAS 3X10 MFZN 3CR	
M211A	7172401652	SCREW TAPPTITE	TT2 TRS 4X16 MFZN BK 3CR	
M211B	7172401252	SCREW TAPPTITE	TT2 TRS 4X12 MFZN BK 3CR	
M352	2TF01612CL	TAPE FILAMENT	12MMX55ME CLEAR	
M481	485487141101	BUTTON POWER	2930 GY340A+SV2405BP	
M481A	4856716000	SPRING	14C1/M3 SWPA PIE0.5	
M561	48556293SD02	MARK BRAND	"DAEWOO 25"29"32" NEW"	
PWC1	4859906210	CORD POWER	W/F 6-LO (LOMAX NEW)	△
SP01A	4856017800	SCREW SPKR FIX	SWRM+SECC 3CR	
SP02A	4856017800	SCREW SPKR FIX	SWRM+SECC 3CR	
V901	4859651760	"CRT (SAMSUNG 29")"	A68QFZ893X002	△
V901A	4857824500	CLOTH BLACK	FELT T1.0 L=500 W=35	
V901B	4857824500	CLOTH BLACK	FELT T1.0 L=500 W=35	
ZZ131	58G0000182	COIL DEGAUSSING	DC-29SF AL	△
ZZ132	48519A7810	CRT GROUND AS	2903S-1015-1P	
ZZ200	PTFMSJF2930S	MASK FRONT AS	DTF-2930FZS-SB	
M201	4TB2M926A305	MASK FRONT	2930 HIPS GY+SV/BK(100HZ)	
ZZ201	PTSPPW2950F	SPEAKER AS	DTF-2950FZF-SB	
51100	4850704S28	CONN AS	YH025-04+35089+ULW=600	
SP01	48A8311400	SPEAKER SYSTEM	SS-58126F04C	
SP02	48A8311400	SPEAKER SYSTEM	SS-58126F04C	
ZZ280	PTU1MSF2930FS	PCB UNION MANUAL AS	DTF-2930FZS-SB	
C801	CL1UC3474M	C LINE ACROSS	0.47MF 1J(UCVS)NDF/SV	△
DL01	DH1L25RS—	LED(REDF)	HI-L25RS	
DL02	DH1L25G—	"LED (R,G-3 COLOR)"	HI-L25G	
F801	5FSCB4022R	FUSE CERA	SEMKO F4AH 4A 250V MF51	△
HP01	4859105240	JACK PHONO	LGT1516-0100	
I703	1TSOP4838Y	IC PREAMP	TSOP34838YA1	
JPA3	4859105450	JACK PIN BOARD	YSC03P-4120-9S	
JPA4	4859105340	JACK S-VHS	DSW-10 (STRAIGHT)	
LF801	5PLF24A3—	FILTER LINE	LF-24A3	△
LF802	58C0000153	COIL CHOKE PFC	6001.0016B	△
M191	485195711106	DECO SENSOR AS	2930 3568811+5556000	
M231	485233251102	PANEL CTRL	2950 ABS GY	
M231A	7178301051	SCREW TAPPTITE	TT2 WAS 3X10 MFZN 3CR	
M491	485496331101	BUTTON CTRL	2950 ABS GY	
P702A	4850703N43	CONNECTOR	YH025-03+YBH250-03+ULW=500	
P703A	4850704S02	CONN AS	YH025-04+YST025+ULW=200	
P801	4859287320	CONN WAFER	MKS2822 (LOMAX NEW TYPE)	
P803	4859238620	CONN WAFER	YPW500-02	
PA01A	4950712003	CONNECTOR	YH025-12+YST250+ULW=450	
SW801	5S40101146	SW POWER PUSH	SS-160-7-B	△
ZZ200	PTU1JBT2950FF	PCB UNION EYE LET AS	DTF-2950FZF-SB	
E1	4856310300	EYE LET	BSR T0.2 (R1.6) SMALL	
E2	4856310300	EYE LET	BSR T0.2 (R1.6) SMALL	
E3	4856310300	EYE LET	BSR T0.2 (R1.6) SMALL	
E4	4856310300	EYE LET	BSR T0.2 (R1.6) SMALL	
E5	4856310300	EYE LET	BSR T0.2 (R1.6) SMALL	
E6	4856310300	EYE LET	BSR T0.2 (R1.6) SMALL	
E7	4856310300	EYE LET	BSR T0.2 (R1.6) SMALL	
ZZ200	PTU1JRT2950FF	PCB UNION RADIAL AS	DTF-2950FZF-SB	
C690	CEXF1H479V	C ELECTRO	50V RSS 4.7MF (5*11) TP	
C691	CEXF1H479V	C ELECTRO	50V RSS 4.7MF (5*11) TP	
C770	CEXF1C101V	C ELECTRO	16V RSS 100MF (6.3X11) TP	

LOC	PART CODE	PART NAME	DESCRIPTION	REMARK
CA21	CCXB1H472K	C CERA	50V B 4700PF K (TAPPING)	
F801A	4857415001	CLIP FUSE	PFC5000-0702	
F801B	4857415001	CLIP FUSE	PFC5000-0702	
Q506	T2SC5343Y-	TR	2SC5343Y	
Q507	T2SA1980Y-	TR	2SA1980Y	
SW700	5S50101290	SW TACT	SKHV10910A	
SW701	5S50101290	SW TACT	SKHV10910A	
SW702	5S50101290	SW TACT	SKHV10910A	
SW703	5S50101290	SW TACT	SKHV10910A	
SW704	5S50101290	SW TACT	SKHV10910A	
SW705	5S50101290	SW TACT	SKHV10910A	
Z601	5PXF1B471M	FILTER EMI	CFI 06 B 1H 470PF	
Z602	5PXF1B471M	FILTER EMI	CFI 06 B 1H 470PF	
Z603	5PXF1B471M	FILTER EMI	CFI 06 B 1H 470PF	
Z604	5PXF1B471M	FILTER EMI	CFI 06 B 1H 470PF	
ZZ200	PTU1JAT2950FF	PCB UNION AXIAL AS	DTF-2950FZF-SB	
10	2TM14006LB	TAPE MASKING	3M #232 6.0X2000M (WITH GLUE)	
20	2TM10006LB	TAPE MASKING	3M #232-MAP-C 6.2X2000M (W/O GLUE)	
A001	4859816424	PCB UNION	CP-650/850FX 246X246(120X210X2)D1B	△
C608	CCZB1H471K	C CERA	50V B 470PF K (AXIAL)	
C609	CCZB1H471K	C CERA	50V B 470PF K (AXIAL)	
CA20	CCZL1H472K	C CERA	50V B 4700PF K AXL (1608)	
DA21	CCZB1H471K	C CERA	50V B 470PF K (AXIAL)	
DA22	CCZB1H471K	C CERA	50V B 470PF K (AXIAL)	
J001	85801060GY	WIRE COPPER	1/0.6 TIN COPPER	
L701	5CPZ560K02	COIL PEAKING	56UH 3.5MM K (LAL02TB)	
R530	RD-AZ151J-	R CARBON FILM	1/6 150 OHM J	
R531	RD-AZ750J-	R CARBON FILM	1/6 75 OHM J	
R532	RD-AZ102J-	R CARBON FILM	1/6 1K OHM J	
R533	RD-AZ102J-	R CARBON FILM	1/6 1K OHM J	
R608	RD-22151J-	R CARBON FILM	1/2 150 OHM J	
R609	RD-22151J-	R CARBON FILM	1/2 150 OHM J	
R701	RD-AZ101J-	R CARBON FILM	1/6 100 OHM J	
R721	RD-AZ181J-	R CARBON FILM	1/6 180 OHM J	
R722	RD-AZ221J-	R CARBON FILM	1/6 220 OHM J	
R723	RD-AZ331J-	R CARBON FILM	1/6 330 OHM J	
R724	RD-AZ471J-	R CARBON FILM	1/6 470 OHM J	
R725	RD-AZ681J-	R CARBON FILM	1/6 680 OHM J	
R802	RD-22824J-	R CARBON FILM	1/2 820K OHM J	
RA22	RD-AZ750J-	R CARBON FILM	1/6 75 OHM J	
ZZ290	PTMPMST2950FS	PCB MAIN MANUAL AS	DTF-2950FZS-SB	
10	2193110001	SOLDER WIRE	SN-3.0AG (NP303T) 3.0	
20	2193110002	SOLDER WIRE	SN-3.0AG-0.5CU (DHB-RMA3)	
30	2291050620	FLUX SOLDER	DF-2810U (0.810)	
40	2291050314	FLUX SOLVENT	IM-1000	
C315	CEXF2A470V	C ELECTRO	100V RSS 47MF (10X16) TP	
C402	CMYH3C752J	C MYLAR	1.6KV 7500PF J (BUP)	
C404	CMYH3C562J	C MYLAR	1.6KV 5600PF J (BUP)	
C405	CMXE2G243J	C MYLAR	400V PU 0.024MF J	
C408	CMYE2G184J	C MYLAR	400V PU 0.18MF J	
C411	CMYF2E105J	C MYLAR	250V MPP 1MF J	
C415	CEXF2E100V	C ELECTRO	250V RSS 10MF (10X20) TP	
C418	CEYD1H689W	C ELECTRO	50V RHD 6.8MF (16X35.5)	
C604	CEXF1E102V	C ELECTRO	25V RSS 1000MF (13X20) TP	
C805	CEYD2G181D	C ELECTRO	400V FHS 180MF	
C812	CH1BF472M	C CERA AC	AC400V 4700PF M U/CV	△
C813	CEXF2E101V	C ELECTRO	250V RSS 100MF 18X35.5	
C814	CEYF2E470V	C ELECTRO	250V RSS 47MF (16X25)	
C820	CCXR3D221K	C CERA	2KV R 220PF K125C	
C823	CEXF1E222V	C ELECTRO	25V RSS 2200MF (16X25) TP	
C840	CEXF1C102V	C ELECTRO	16V RSS 1000MF (10X20) TP	
C861	CEXF1E102C	C ELECTRO	25V RSS 1000MF 13X20 TP	
C899	CMXF2J333J	C MYLAR	630V MPP 0.033MF J	
CP01	CMYF2G224J	C MYLAR	400V MPU 0.22MF J	
CP02	CMXE2J222J	C MYLAR	630V PU 2200PF	
CP04	CEXF1H221V	C ELECTRO	50V RSS 220MF (10X16) TP	
CP07	CMYF2J154J	C MYLAR	630V MPP 0.15MF J	
D401	DDTV1500MD	DIODE	DTV1500MD TO-220AC01	
D404	DFMP3FU—	DIODE	FMP3FU	
D404A	4857027603	HEAT SINK	AL EX	

LOC	PART CODE	PART NAME	DESCRIPTION	REMARK
D404B	7174301051	SCREW TAPPTITE	TT2 RND 3X10 MFZN 3CR	
D406	DRGP30J—	DIODE	RGF30J	
D820	DRGP30J—	DIODE	RGF30J	
D860	DRGP30J—	DIODE	RGF30J	
D870	DRGP30J—	DIODE	RGF30J	
I301	1TDA8358J-	IC VERTICAL	TDA8358J	
I301A	4857028219	HEAT SINK	AL EX ANODIZING	
I301B	7174301051	SCREW TAPPTITE	TT2 RND 3X10 MFZN 3CR	
I601	1MSP3410V3	IC SOUND	MSP3410G-V3	
I602	1TDA8946J-	IC AUDIO	TDA8946J	
I602A	4857028215	HEAT SINK	AL EX NO ANODOZING	
I602B	7174301051	SCREW TAPPTITE	TT2 RND 3X10 MFZN 3CR	
I701	1SDA555XFL	IC MICOM OTP	SDA555XFL/PO	
I702	1M24C16BN6	IC MEMORY	M24C16WRN6	
I801	1STRW6754-	IC POWER	STR-W6754	
I801A	4857024600	HEAT SINK	AL EX B/K	
I801B	7174300851	SCREW TAPPTITE	TT2 RND 3X8 MFZN 3CR	
I804	1LTV817C—	IC PHOTO COUPLER	LTV-817C	△
I806	1DP125—	IC ERROR AMP	DP125	
I820	1S7805P1C-	IC REGULATOR	S7805PIC 5.0V 1.0A	
I821	1K78R33—	IC REGULATOR	KIA78R33AP	
I822	1K78R08—	IC REGULATOR	KIA78R08API	
I822A	4857026900	HEAT SINK	AL EX	
I822B	7174300851	SCREW TAPPTITE	TT2 RND 3X8 MFZN 3CR	
I824	1K78R018P1	IC REGULATOR	KIA78R018P1	
I825	1K78R05—	IC REGULATOR	KIA78R05PI	
I826	1A1117P133	IC REGULATOR	KIA1117P133 3.3V TO-220IS	
JPA1	4859200401	SOCKET RGB	SR-21A1 (ANGLE TYPE)	
JPA2	4859200401	SOCKET RGB	SR-21A1 (ANGLE TYPE)	
L150	58E0000041	COIL AFT	TRF-A005	
L401	58H0000054	COIL H-LINEARITY	TRL-040F	
L403	58C0000130	COIL CHOKE	CH-161A	
P401	4850705S04	CONN AS	YH025-05+YST025+ULW=400	
P402	4859242420	CONN WAFER	YFW800-04	
P404	4859242220	CONN WAFER	YFW800-02	
P501	4850708N15	CONNECTOR	YH025-08+YBNH250+USW=600	
P601	4859231720	CONN WAFER	YW025-04	
P702	4859231620	CONN WAFER	YW025-03	
P703	4859231720	CONN WAFER	YW025-04	
P802	4859242220	CONN WAFER	YFW800-02	
P804	4859238620	CONN WAFER	YPW500-02	
P804A	4850702N08	CONN AS	YPH500-02+YLT500+USW=300	
PA01	4859235520	CONN WAFER	YW025-12	
Q401	TST2310DH1	TR	ST2310DH1	
Q401A	4857033201	HEAT SINK	AL EX BK (ANODIZING)	
Q401B	7174301051	SCREW TAPPTITE	TT2 RND 3X10 MFZN 3CR	
Q807	TKTA1659AY	TR	KTA1659AY	
QP03	T1RF640N—	FET	IRF640NPBF	
QP03A	4857026900	HEAT SINK	AL EX	
QP03B	7174300851	SCREW TAPPTITE	TT2 RND 3X8 MFZN 3CR	
R388	RW02Y678FS	R WIRE WOUND	2W 0.67 OHM F SMALL	
R399	RS02Y829JS	R M-OXIDE FILM	2W 8.2 OHM J SMALL	
R407	RF01Y129JA	R FUSIBLE	1W 1.2 OHM J A CURVE	
R444	RS02Y330JS	R M-OXIDE FILM	2W 33 OHM J SMALL	
R801	DJ5020M270	POSISTOR	J502P72D070M270	△
R803	RS02Y338JS	R M-OXIDE FILM	2W 0.33 OHM J SMALL	
R806	RS02Y228JS	R M-OXIDE FILM	2W 0.22 OHM J SMALL	
R819	RX07B339JP	R CEMENT	7W 3.3 OHM J BEN 15MM 4P	
R841	RS02Y309JS	R M-OXIDE FILM	2W 3 OHM J SMALL	
R850	RS02Y569JS	R M-OXIDE FILM	2W 5.6 OHM J SMALL	
R852	RS02Y569JS	R M-OXIDE FILM	2W 5.6 OHM J SMALL	
R854	RS02Y569JS	R M-OXIDE FILM	2W 5.6 OHM J SMALL	
R885	RS02Y339JS	R M-OXIDE FILM	2W 3.3 OHM J SMALL	
R899	RS02Y683J-	R M-OXIDE FILM	2W 68K OHM J	
SF1	5PK3953M—	FILTER SAW	K3953M	
SF2	5PK9650M—	FILTER SAW	K9650M	
T401	50D25A2—	TRANS DRIVE	TD-25A2	
T402	50H0000317	FBT	1372.0136	△
T801	50M4818A2-	TRANS SMPS	2094.0119	△
U100	4859724930	TUNER VARACTOR	UV1316/Al-4	

LOC	PART CODE	PART NAME	DESCRIPTION	REMARK
X501	5XE20R250E	CRYSTAL QUARTZ	HC-49/U 20.2500MHZ 30PPM	
X601	5XE18R432E	CRYSTAL QUARTZ	HC-49/U 18.43200MHZ 30PPM	
Y801	5SC0101003	SW RELAY	DG12D1-0(M)-H1 1C-1P	△
Z153	5PXT5R5MB	FILTER CERA	XT 5.5MB (TAPPING)	
Z2200	PTMPJBT2950FS	PCB MAIN EYE LET AS	DTF-2950FZS-SB	
E1	4856310600	EYE LET	BSR 2.3(R2.3) BIG	
E10	4856310300	EYE LET	BSR T0.2 (R1.6) SMALL	
E11	4856310300	EYE LET	BSR T0.2 (R1.6) SMALL	
E12	4856310600	EYE LET	BSR 2.3(R2.3) BIG	
E13	4856310600	EYE LET	BSR 2.3(R2.3) BIG	
E14	4856310600	EYE LET	BSR 2.3(R2.3) BIG	
E15	4856310600	EYE LET	BSR 2.3(R2.3) BIG	
E16	4856310600	EYE LET	BSR 2.3(R2.3) BIG	
E17	4856310600	EYE LET	BSR 2.3(R2.3) BIG	
E18	4856310600	EYE LET	BSR 2.3(R2.3) BIG	
E19	4856310600	EYE LET	BSR 2.3(R2.3) BIG	
E2	4856310600	EYE LET	BSR 2.3(R2.3) BIG	
E20	4856310600	EYE LET	BSR 2.3(R2.3) BIG	
E21	4856310600	EYE LET	BSR 2.3(R2.3) BIG	
E22	4856310600	EYE LET	BSR 2.3(R2.3) BIG	
E23	4856310600	EYE LET	BSR 2.3(R2.3) BIG	
E24	4856310600	EYE LET	BSR 2.3(R2.3) BIG	
E25	4856310600	EYE LET	BSR 2.3(R2.3) BIG	
E26	4856310600	EYE LET	BSR 2.3(R2.3) BIG	
E27	4856310300	EYE LET	BSR T0.2 (R1.6) SMALL	
E28	4856310300	EYE LET	BSR T0.2 (R1.6) SMALL	
E29	4856310300	EYE LET	BSR T0.2 (R1.6) SMALL	
E3	4856310600	EYE LET	BSR 2.3(R2.3) BIG	
E30	4856310300	EYE LET	BSR T0.2 (R1.6) SMALL	
E31	4856310300	EYE LET	BSR T0.2 (R1.6) SMALL	
E32	4856310300	EYE LET	BSR T0.2 (R1.6) SMALL	
E33	4856310300	EYE LET	BSR T0.2 (R1.6) SMALL	
E34	4856310300	EYE LET	BSR T0.2 (R1.6) SMALL	
E35	4856310300	EYE LET	BSR T0.2 (R1.6) SMALL	
E36	4856310600	EYE LET	BSR 2.3(R2.3) BIG	
E37	4856310600	EYE LET	BSR 2.3(R2.3) BIG	
E38	4856310600	EYE LET	BSR 2.3(R2.3) BIG	
E39	4856310600	EYE LET	BSR 2.3(R2.3) BIG	
E4	4856310600	EYE LET	BSR 2.3(R2.3) BIG	
E40	4856310300	EYE LET	BSR T0.2 (R1.6) SMALL	
E41	4856310300	EYE LET	BSR T0.2 (R1.6) SMALL	
E42	4856310300	EYE LET	BSR T0.2 (R1.6) SMALL	
E43	4856310300	EYE LET	BSR T0.2 (R1.6) SMALL	
E48	4856310300	EYE LET	BSR T0.2 (R1.6) SMALL	
E49	4856310300	EYE LET	BSR T0.2 (R1.6) SMALL	
E5	4856310600	EYE LET	BSR 2.3(R2.3) BIG	
E50	4856310300	EYE LET	BSR T0.2 (R1.6) SMALL	
E51	4856310300	EYE LET	BSR T0.2 (R1.6) SMALL	
E52	4856310300	EYE LET	BSR T0.2 (R1.6) SMALL	
E53	4856310300	EYE LET	BSR T0.2 (R1.6) SMALL	
E54	4856310300	EYE LET	BSR T0.2 (R1.6) SMALL	
E56	4856310300	EYE LET	BSR T0.2 (R1.6) SMALL	
E57	4856310300	EYE LET	BSR T0.2 (R1.6) SMALL	
E58	4856310300	EYE LET	BSR T0.2 (R1.6) SMALL	
E6	4856310600	EYE LET	BSR 2.3(R2.3) BIG	
E62	4856310300	EYE LET	BSR T0.2 (R1.6) SMALL	
E63	4856310300	EYE LET	BSR T0.2 (R1.6) SMALL	
E7	4856310600	EYE LET	BSR 2.3(R2.3) BIG	
E8	4856310300	EYE LET	BSR T0.2 (R1.6) SMALL	
E9	4856310300	EYE LET	BSR T0.2 (R1.6) SMALL	
Z2200	PTMPJ2T2950FS	PCB CHIP MOUNT B AS	DTF-2950FZS-SB	
CC01	HCBK471KBA	C CHIP CERA	50V X7R 470PF K 1608	
CC02	HCBK471KBA	C CHIP CERA	50V X7R 470PF K 1608	
CC03	HCBK471KBA	C CHIP CERA	50V X7R 470PF K 1608	
CC04	HCBK471KBA	C CHIP CERA	50V X7R 470PF K 1608	
CC05	HCBK471KBA	C CHIP CERA	50V X7R 470PF K 1608	
CC06	HCBK471KBA	C CHIP CERA	50V X7R 470PF K 1608	
CC07	HCBK471KBA	C CHIP CERA	50V X7R 470PF K 1608	
CC08	HCBK471KBA	C CHIP CERA	50V X7R 470PF K 1608	
CC10	HCBK102KBA	C CHIP CERA	50V X7R 1000PF K 1608	

CP-850/F Service Manual

LOC	PART CODE	PART NAME	DESCRIPTION	REMARK
CC101	HCBK102KBA	C CHIP CERA	50V X7R 1000PF K 1608	
CC103	HCBK102KBA	C CHIP CERA	50V X7R 1000PF K 1608	
CC110	HCBK103KBA	C CHIP CERA	50V X7R 0.01MF K 1608	
CC115	HCBK104KBA	C CHIP CERA	50V X7R 0.1MF K 1608	
CC117	HCBK103KBA	C CHIP CERA	50V X7R 0.01MF K 1608	
CC119	HCBK103KBA	C CHIP CERA	50V X7R 0.01MF K 1608	
CC127	HCBK102KBA	C CHIP CERA	50V X7R 1000PF K 1608	
CC129	HCBK103KBA	C CHIP CERA	50V X7R 0.01MF K 1608	
CC13	HCBK102KBA	C CHIP CERA	50V X7R 1000PF K 1608	
CC136	HCBK104KBA	C CHIP CERA	50V X7R 0.1MF K 1608	
CC14	HCBK102KBA	C CHIP CERA	50V X7R 1000PF K 1608	
CC15	HCBK102KBA	C CHIP CERA	50V X7R 1000PF K 1608	
CC158	HCBK104KBA	C CHIP CERA	50V X7R 0.1MF K 1608	
CC16	HCBK102KBA	C CHIP CERA	50V X7R 1000PF K 1608	
CC160	HCBK103KBA	C CHIP CERA	50V X7R 0.01MF K 1608	
CC166	HCQK470JBA	C CHIP CERA	50V CH 47PF J 1608	
CC17	HCBK102KBA	C CHIP CERA	50V X7R 1000PF K 1608	
CC177	HCQK470JBA	C CHIP CERA	50V CH 47PF J 1608	
CC18	HCBK102KBA	C CHIP CERA	50V X7R 1000PF K 1608	
CC19	HCBK102KBA	C CHIP CERA	50V X7R 1000PF K 1608	
CC501	HCBK102KBA	C CHIP CERA	50V X7R 1000PF K 1608	
CC502	HCBK102KBA	C CHIP CERA	50V X7R 1000PF K 1608	
CC503	HCFF334ZBA	C CHIP CERA	16V Y5V 0.33MF Z 1608	
CC504	HCQK100JBA	C CHIP CERA	50V CH 10PF J 1608	
CC505	HCBK102KBA	C CHIP CERA	50V X7R 1000PF K 1608	
CC506	HCBK104KBA	C CHIP CERA	50V X7R 0.1MF K 1608	
CC507	HCBK102KBA	C CHIP CERA	50V X7R 1000PF K 1608	
CC508	HCBK102KBA	C CHIP CERA	50V X7R 1000PF K 1608	
CC509	HCBK102KBA	C CHIP CERA	50V X7R 1000PF K 1608	
CC511	HCBK102KBA	C CHIP CERA	50V X7R 1000PF K 1608	
CC512	HCBK102KBA	C CHIP CERA	50V X7R 1000PF K 1608	
CC513	HCBK102KBA	C CHIP CERA	50V X7R 1000PF K 1608	
CC514	HCBK104KBA	C CHIP CERA	50V X7R 0.1MF K 1608	
CC515	HCQK470JBA	C CHIP CERA	50V CH 47PF J 1608	
CC516	HCQK470JBA	C CHIP CERA	50V CH 47PF J 1608	
CC517	HCBK104KBA	C CHIP CERA	50V X7R 0.1MF K 1608	
CC518	HCBK104KBA	C CHIP CERA	50V X7R 0.1MF K 1608	
CC521	HCBK104KBA	C CHIP CERA	50V X7R 0.1MF K 1608	
CC522	HCBK104KBA	C CHIP CERA	50V X7R 0.1MF K 1608	
CC523	HCBK104KBA	C CHIP CERA	50V X7R 0.1MF K 1608	
CC524	HCBK102KBA	C CHIP CERA	50V X7R 1000PF K 1608	
CC526	HCQK220JBA	C CHIP CERA	50V CH 22PF J 1608	
CC527	HCQK220JBA	C CHIP CERA	50V CH 22PF J 1608	
CC528	HCBK102KBA	C CHIP CERA	50V X7R 1000PF K 1608	
CC549	HCBK104KBA	C CHIP CERA	50V X7R 0.1MF K 1608	
CC550	HCBK104KBA	C CHIP CERA	50V X7R 0.1MF K 1608	
CC551	HCBK104KBA	C CHIP CERA	50V X7R 0.1MF K 1608	
CC552	HCQK270JBA	C CHIP CERA	50V CH 27PF J 1608	
CC553	HCQK270JBA	C CHIP CERA	50V CH 27PF J 1608	
CC556	HCBK102KBA	C CHIP CERA	50V X7R 1000PF K 1608	
CC560	HCBK102KBA	C CHIP CERA	50V X7R 1000PF K 1608	
CC561	HCBK104KBA	C CHIP CERA	50V X7R 0.1MF K 1608	
CC567	HCBK102KBA	C CHIP CERA	50V X7R 1000PF K 1608	
CC568	HCBK104KBA	C CHIP CERA	50V X7R 0.1MF K 1608	
CC569	HCBK102KBA	C CHIP CERA	50V X7R 1000PF K 1608	
CC570	HCBK104KBA	C CHIP CERA	50V X7R 0.1MF K 1608	
CC578	HCBK561KBA	C CHIP CERA	50V X7R 560PF K 1608	
CC579	HCBK561KBA	C CHIP CERA	50V X7R 560PF K 1608	
CC589	HCBK561KBA	C CHIP CERA	50V X7R 560PF K 1608	
CC601	HCBK472KBA	C CHIP CERA	50V X7R 4700PF K 1608	
CC602	HCBK472KBA	C CHIP CERA	50V X7R 4700PF K 1608	
CC617	HCBK104KBA	C CHIP CERA	50V X7R 0.1MF K 1608	
CC620	HCQK309CBA	C CHIP CERA	50V CH 3PF C 1608	
CC621	HCQK309CBA	C CHIP CERA	50V CH 3PF C 1608	
CC622	HCQK680JBA	C CHIP CERA	50V CH 68PF J 1608	
CC629	HCBK104KBA	C CHIP CERA	50V X7R 0.1MF K 1608	
CC631	HCBK104KBA	C CHIP CERA	50V X7R 0.1MF K 1608	
CC635	HCBK104KBA	C CHIP CERA	50V X7R 0.1MF K 1608	
CC665	HCBK222KBA	C CHIP CERA	50V X7R 2200PF K 1608	
CC667	HCBK222KBA	C CHIP CERA	50V X7R 2200PF K 1608	
CC680	HCBK102KBA	C CHIP CERA	50V X7R 1000PF K 1608	

LOC	PART CODE	PART NAME	DESCRIPTION	REMARK
CC701	HCBK103KBA	C CHIP CERA	50V X7R 0.01MF K 1608	
CC709	HCBK104KBA	C CHIP CERA	50V X7R 0.1MF K 1608	
CC710	HCBK104KBA	C CHIP CERA	50V X7R 0.1MF K 1608	
CC711	HCBK104KBA	C CHIP CERA	50V X7R 0.1MF K 1608	
CC712	HCQK151JBA	C CHIP CERA	50V CH 150PF J 1608	
CC713	HCBK104KBA	C CHIP CERA	50V X7R 0.1MF K 1608	
CC714	HCBK103KBA	C CHIP CERA	50V X7R 0.01MF K 1608	
CC715	HCBK104KBA	C CHIP CERA	50V X7R 0.1MF K 1608	
CC716	HCBK103KBA	C CHIP CERA	50V X7R 0.01MF K 1608	
CC722	HCBK102KBA	C CHIP CERA	50V X7R 1000PF K 1608	
CC726	HCQK330JBA	C CHIP CERA	50V CH 33PF J 1608	
CC727	HCQK330JBA	C CHIP CERA	50V CH 33PF J 1608	
CC730	HCBK104KBA	C CHIP CERA	50V X7R 0.1MF K 1608	
CC737	HCBK102KBA	C CHIP CERA	50V X7R 1000PF K 1608	
CC742	HCBK102KBA	C CHIP CERA	50V X7R 1000PF K 1608	
CC744	HCBK102KBA	C CHIP CERA	50V X7R 1000PF K 1608	
CC777	HCBK104KBA	C CHIP CERA	50V X7R 0.1MF K 1608	
IC101	14470MFLGD	IC CHIP VIDEO IF	TDA4470-MFLG3	
IC501	1VSP9405C4	IC CHIP VIDEO	VSP9405C4	
IC502	1DDP3315CQ	IC CHIP	DDP3315CQ	
RC102	HRFT561JBA	R CHIP	1/10 560 OHM J 1608	
RC106	HRFT101JBA	R CHIP	1/10 100 OHM J 1608	
RC107	HRFT101JBA	R CHIP	1/10 100 OHM J 1608	
RC109	HRFT104JBA	R CHIP	1/10 100K OHM J 1608	
RC111	HRFT113JBA	R CHIP	1/10 11K OHM J 1608	
RC112	HRFT223JBA	R CHIP	1/10 22K OHM J 1608	
RC114	HRFT472JBA	R CHIP	1/10 4.7K OHM J 1608	
RC118	HRFT151JBA	R CHIP	1/10 150 OHM J 1608	
RC119	HRFT272JBA	R CHIP	1/10 2.7K OHM J 1608	
RC151	HRFT102JBA	R CHIP	1/10 1K OHM J 1608	
RC159	HRFT682JBA	R CHIP	1/10 6.8K OHM J 1608	
RC160	HRFT472JBA	R CHIP	1/10 4.7K OHM J 1608	
RC164	HRFT752JBA	R CHIP	1/10 7.5K OHM J 1608	
RC169	HRFT222JBA	R CHIP	1/10 2.2K OHM J 1608	
RC179	HRFT222JBA	R CHIP	1/10 2.2K OHM J 1608	
RC190	HRFT221JBA	R CHIP	1/10 220 OHM J 1608	
RC191	HRFT331JBA	R CHIP	1/10 330 OHM J 1608	
RC501	HRFT221JBA	R CHIP	1/10 220 OHM J 1608	
RC506	HRFT750JBA	R CHIP	1/10 75 OHM J 1608	
RC509	HRFT472JBA	R CHIP	1/10 4.7K OHM J 1608	
RC513	HRFT103JBA	R CHIP	1/10 10K OHM J 1608	
RC516	HRFT471JBA	R CHIP	1/10 470 OHM J 1608	
RC517	HRFT332JBA	R CHIP	1/10 3.3K OHM J 1608	
RC518	HRFT151JBA	R CHIP	1/10 150 OHM J 1608	
RC519	HRFT151JBA	R CHIP	1/10 150 OHM J 1608	
RC527	HRFT333JBA	R CHIP	1/10 33K OHM J 1608	
RC530	HRFT103JBA	R CHIP	1/10 10K OHM J 1608	
RC532	HRFT223JBA	R CHIP	1/10 22K OHM J 1608	
RC551	HRFT471JBA	R CHIP	1/10 470 OHM J 1608	
RC560	HRFT102JBA	R CHIP	1/10 1K OHM J 1608	
RC568	HRFT102JBA	R CHIP	1/10 1K OHM J 1608	
RC577	HRFT151JBA	R CHIP	1/10 150 OHM J 1608	
RC578	HRFT330JBA	R CHIP	1/10 33 OHM J 1608	
RC579	HRFT330JBA	R CHIP	1/10 33 OHM J 1608	
RC580	HRFT821JBA	R CHIP	1/10 820 OHM J 1608	
RC581	HRFT102JBA	R CHIP	1/10 1K OHM J 1608	
RC582	HRFT102JBA	R CHIP	1/10 1K OHM J 1608	
RC583	HRFT102JBA	R CHIP	1/10 1K OHM J 1608	
RC584	HRFT821JBA	R CHIP	1/10 820 OHM J 1608	
RC585	HRFT911JBA	R CHIP	1/10 910 OHM J 1608	
RC586	HRFT911JBA	R CHIP	1/10 910 OHM J 1608	
RC587	HRFT821JBA	R CHIP	1/10 820 OHM J 1608	
RC589	HRFT330JBA	R CHIP	1/10 33 OHM J 1608	
RC591	HRFT393JBA	R CHIP	1/10 39K OHM J 1608	
RC595	HRFT271JBA	R CHIP	1/10 270 OHM J 1608	
RC598	HRFT271JBA	R CHIP	1/10 270 OHM J 1608	
RC611	HRFT224JBA	R CHIP	1/10 220K OHM J 1608	
RC661	HRFT512JBA	R CHIP	1/10 5.1K OHM J 1608	
RC662	HRFT512JBA	R CHIP	1/10 5.1K OHM J 1608	
RC701	HRFT103JBA	R CHIP	1/10 10K OHM J 1608	
RC708	HRFT472JBA	R CHIP	1/10 4.7K OHM J 1608	

LOC	PART CODE	PART NAME	DESCRIPTION	REMARK
RC715	HRFT103JBA	R CHIP	1/10 10K OHM J 1608	
RC716	HRFT113JBA	R CHIP	1/10 11K OHM J 1608	
RC725	HRFT103JBA	R CHIP	1/10 10K OHM J 1608	
RC729	HRFT103JBA	R CHIP	1/10 10K OHM J 1608	
RC730	HRFT223JBA	R CHIP	1/10 22K OHM J 1608	
RC731	HRFT223JBA	R CHIP	1/10 22K OHM J 1608	
RC732	HRFT103JBA	R CHIP	1/10 10K OHM J 1608	
RC733	HRFT473JBA	R CHIP	1/10 47K OHM J 1608	
RC737	HRFT682JBA	R CHIP	1/10 6.8K OHM J 1608	
RC738	HRFT000-BA	R CHIP	1/10 0 OHM 1608	
RC739	HRFT000-BA	R CHIP	1/10 0 OHM 1608	
RC740	HRFT000-BA	R CHIP	1/10 0 OHM 1608	
RC741	HRFT682JBA	R CHIP	1/10 6.8K OHM J 1608	
RC742	HRFT682JBA	R CHIP	1/10 6.8K OHM J 1608	
RC743	HRFT682JBA	R CHIP	1/10 6.8K OHM J 1608	
RC750	HRFT183JBA	R CHIP	1/10 18K OHM J 1608	
RC770	HRFT332JBA	R CHIP	1/10 3.3K OHM J 1608	
RC799	HRFT472JBA	R CHIP	1/10 4.7K OHM J 1608	
RC881	HRFT103JBA	R CHIP	1/10 10K OHM J 1608	
RC882	HRFT103JBA	R CHIP	1/10 10K OHM J 1608	
ZZ200	PTMPJRT2950FS	PCB MAIN RADIAL AS	DTF-2950FZS-SB	
C102	CEXF1E470V	C ELECTRO	25V RSS 47MF (5X11) TP	
C106	CEXF1C221V	C ELECTRO	16V RSS 220MF (8X11.5) TP	
C117	CEXF1H229V	C ELECTRO	50V RSS 2.2MF (5X11) TP	
C118	CMXL1J474J	C MYLAR	63V 0.47MF MKT	
C120	CXRH1H150J	C CERA	50V RH 15PF J (TAPPING)	
C121	CEXF1E470V	C ELECTRO	25V RSS 47MF (5X11) TP	
C150	CEXF1E100V	C ELECTRO	25V RSS 10MF TP	
C152	CEXF1E100V	C ELECTRO	25V RSS 10MF TP	
C153	CEXF1H229V	C ELECTRO	50V RSS 2.2MF (5X11) TP	
C157	CEXF1E100V	C ELECTRO	25V RSS 10MF TP	
C164	CEXF1E470V	C ELECTRO	25V RSS 47MF (5X11) TP	
C188	CEXF1E100V	C ELECTRO	25V RSS 10MF TP	
C301	CMXM2A224J	C MYLAR	100V 0.22MF J	
C305	CEXF1E221V	C ELECTRO	25V RSS 220MF (8X11.5) TP	
C313	CMXM2A104J	C MYLAR	100V 0.1MF J TP	
C320	CBXF1H104Z	C CERA SEMI	50V F 0.1MF Z (TAPPING)	
C340	CMXM2A683J	C MYLAR	100V 0.068MF J TP	
C350	CMXM2A223J	C MYLAR	100V 0.022MF J TP	
C351	CMXM2A223J	C MYLAR	100V 0.022MF J TP	
C401	CEXF1E101V	C ELECTRO	25V RSS 100MF (6.3X11) TP	
C410	CCXB2H681K	C CERA	500V B 680PF K (TAPPING)	
C416	CCXB2H471K	C CERA	500V B 470PF K (TAPPING)	
C417	CMXM2A392J	C MYLAR	100V 3900PF J TP	
C420	CMXM2A273J	C MYLAR	100V 0.027MF J TP	
C424	CMXM2A333J	C MYLAR	100V 0.033MF J TP	
C425	CCXB1H472K	C CERA	50V B 4700PF K (TAPPING)	
C501	CEXF1E100V	C ELECTRO	25V RSS 10MF TP	
C502	CEXF1E100V	C ELECTRO	25V RSS 10MF TP	
C503	CEXF1E100V	C ELECTRO	25V RSS 10MF TP	
C504	CEXF1E100V	C ELECTRO	25V RSS 10MF TP	
C505	CEXF1E100V	C ELECTRO	25V RSS 10MF TP	
C506	CEXF1E100V	C ELECTRO	25V RSS 10MF TP	
C524	CEXF1E470V	C ELECTRO	25V RSS 47MF (5X11) TP	
C530	CEXF1E100V	C ELECTRO	25V RSS 10MF TP	
C550	CEXF1E100V	C ELECTRO	25V RSS 10MF TP	
C551	CEXF1E100V	C ELECTRO	25V RSS 10MF TP	
C560	CEXF1E101V	C ELECTRO	25V RSS 100MF (6.3X11) TP	
C561	CEXF1H339V	C ELECTRO	50V RSS 3.3MF (5X11) TP	
C568	CEXF1E101V	C ELECTRO	25V RSS 100MF (6.3X11) TP	
C590	CEXF1H479V	C ELECTRO	50V RSS 4.7MF (5*11) TP	
C602	CEXF1E101V	C ELECTRO	25V RSS 100MF (6.3X11) TP	
C605	CEXF1E470V	C ELECTRO	25V RSS 47MF (5X11) TP	
C608	CEXF1E100V	C ELECTRO	25V RSS 10MF TP	
C610	CEXF1E100V	C ELECTRO	25V RSS 10MF TP	
C611	CEXF1H339V	C ELECTRO	50V RSS 3.3MF (5X11) TP	
C612	CEXF1H109V	C ELECTRO	50V RSS 1MF (5X11) TP	
C613	CEXF1H109V	C ELECTRO	50V RSS 1MF (5X11) TP	
C614	CEXF1H109V	C ELECTRO	50V RSS 1MF (5X11) TP	
C615	CEXF1H109V	C ELECTRO	50V RSS 1MF (5X11) TP	
C616	CEXF1E100V	C ELECTRO	25V RSS 10MF TP	

LOC	PART CODE	PART NAME	DESCRIPTION	REMARK
C623	CEXF1H109V	C ELECTRO	50V RSS 1MF (5X11) TP	
C624	CEXF1H109V	C ELECTRO	50V RSS 1MF (5X11) TP	
C625	CEXF1E101V	C ELECTRO	25V RSS 100MF (6.3X11) TP	
C626	CEXF1E101V	C ELECTRO	25V RSS 100MF (6.3X11) TP	
C627	CEXF1H479V	C ELECTRO	50V RSS 4.7MF (5*11) TP	
C630	CEXF1E470V	C ELECTRO	25V RSS 47MF (5X11) TP	
C634	CEXF1E100V	C ELECTRO	25V RSS 10MF TP	
C636	CEXF1E470V	C ELECTRO	25V RSS 47MF (5X11) TP	
C641	CEXF1E101V	C ELECTRO	25V RSS 100MF (6.3X11) TP	
C642	CEXF1E101V	C ELECTRO	25V RSS 100MF (6.3X11) TP	
C660	CEXF1E100V	C ELECTRO	25V RSS 10MF TP	
C661	CMXM2A224J	C MYLAR	100V 0.22MF J	
C662	CMXM2A224J	C MYLAR	100V 0.22MF J	
C666	CBXF1H104Z	C CERA SEMI	50V F 0.1MF Z (TAPPING)	
C668	CMXM2A224J	C MYLAR	100V 0.22MF J	
C669	CMXM2A224J	C MYLAR	100V 0.22MF J	
C709	CEXF1E101V	C ELECTRO	25V RSS 100MF (6.3X11) TP	
C711	CEXF1E101V	C ELECTRO	25V RSS 100MF (6.3X11) TP	
C713	CEXF1E100V	C ELECTRO	25V RSS 10MF TP	
C730	CEXF1E100V	C ELECTRO	25V RSS 10MF TP	
C733	CEXF1H229V	C ELECTRO	50V RSS 2.2MF (5X11) TP	
C737	CEXF1E100V	C ELECTRO	25V RSS 10MF TP	
C742	CEXF1E100V	C ELECTRO	25V RSS 10MF TP	
C744	CEXF1E100V	C ELECTRO	25V RSS 10MF TP	
C803	CCXF3A472Z	C CERA	1KV F 4700PF Z (T)	
C804	CCXF3A472Z	C CERA	1KV F 4700PF Z (T)	
C806	CCXR3A102K	C CERA	1KV R 1000PF (T) 125C	
C807	CEXF1H109V	C ELECTRO	50V RSS 1MF (5X11) TP	
C810	CEXF1H100V	C ELECTRO	50V RSS 10MF (5X11) TP	
C811	CMXM2A473J	C MYLAR	100V 0.047MF J TP	
C830	CEXF1H479V	C ELECTRO	50V RSS 4.7MF (5*11) TP	
C831	CEXF1H109V	C ELECTRO	50V RSS 1MF (5X11) TP	
C833	CCXB1H821K	C CERA	50V B 820PF K (TAPPING)	
C835	CEXF1E470V	C ELECTRO	25V RSS 47MF (5X11) TP	
C845	CEXF1E101V	C ELECTRO	25V RSS 100MF (6.3X11) TP	
C846	CEXF1E101V	C ELECTRO	25V RSS 100MF (6.3X11) TP	
C847	CEXF1H100V	C ELECTRO	50V RSS 10MF (5X11) TP	
C850	CEXF1H100V	C ELECTRO	50V RSS 10MF (5X11) TP	
C853	CCXF3A472Z	C CERA	1KV F 4700PF Z (T)	
C854	CCXF3A472Z	C CERA	1KV F 4700PF Z (T)	
C863	CEXF1E101V	C ELECTRO	25V RSS 100MF (6.3X11) TP	
C864	CEXF1H100V	C ELECTRO	50V RSS 10MF (5X11) TP	
C865	CEXF1H100V	C ELECTRO	50V RSS 10MF (5X11) TP	
C866	CCXR3A471K	C CERA	1KV R 470PF K 125C	
C871	CEXF1C471V	C ELECTRO	16V RSS 470MF (10X12.5)TP	
C880	CEXF1E101V	C ELECTRO	25V RSS 100MF (6.3X11) TP	
C888	CEXF1E220V	C ELECTRO	25V RSS 22MF TP	
CP05	CEXF1H100V	C ELECTRO	50V RSS 10MF (5X11) TP	
CP06	CCXB3A102K	C CERA	1KV B 1000PF K (TAPPING)	
I704	1K1A7025AP	IC RESET	KIA7025AP	
L101	5CPX479K—	COIL PEAKING	4.7UH K RADIAL	
L380	58C0000116	COIL BEAD	HC-3550R	
L381	58C0000116	COIL BEAD	HC-3550R	
L802	58CX430599	COIL CHOKE	AZ-9004Y 940K TP	
Q103	T2SC5343Y-	TR	2SC5343Y	
Q104	T2SC5343Y-	TR	2SC5343Y	
Q110	T2SC5343Y-	TR	2SC5343Y	
Q150	T2SC5343Y-	TR	2SC5343Y	
Q151	T2SC5343Y-	TR	2SC5343Y	
Q333	T2SC5343Y-	TR	2SC5343Y	
Q334	T2SC5343Y-	TR	2SC5343Y	
Q402	T2SD1207T-	TR	2SD1207-T (TAPPING)	
Q502	T2SC5343Y-	TR	2SC5343Y	
Q503	T2SC5343Y-	TR	2SC5343Y	
Q504	T2SA1980Y-	TR	2SA1980Y	
Q542	T2SA1980Y-	TR	2SA1980Y	
Q543	T2SA1980Y-	TR	2SA1980Y	
Q544	T2SA1980Y-	TR	2SA1980Y	
Q550	T2SC5343Y-	TR	2SC5343Y	
Q601	T2SA1980Y-	TR	2SA1980Y	
Q602	T2SC5343Y-	TR	2SC5343Y	

CP-850/F Service Manual

LOC	PART CODE	PART NAME	DESCRIPTION	REMARK
Q603	T2SA1980Y-	TR	2SA1980Y	
Q604	T2SC5343Y-	TR	2SC5343Y	
Q605	T2SC5343Y-	TR	2SC5343Y	
Q730	T2SC5343Y-	TR	2SC5343Y	
Q731	T2SC5343Y-	TR	2SC5343Y	
Q809	T2SC5343Y-	TR	2SC5343Y	
Q810	T2SC5343Y-	TR	2SC5343Y	
Q812	TKTC3203Y-	TR	KTC3203-Y	
QP01	T2SD1207T-	TR	2SD1207-T (TAPPING)	
QP02	T2SC5343Y-	TR	2SC5343Y	
R331	RN02B561JS	R METAL FILM	2W 560 OHM J SMALL	
R332	RN02B561JS	R METAL FILM	2W 560 OHM J SMALL	
R401	RN02B360JS	R METAL FILM	2W 36 OHM J SMALL	
R402	RN02B360JS	R METAL FILM	2W 36 OHM J SMALL	
R410	RN02B473JS	R METAL FILM	2W 47K OHM J SMALL	
R415	RN02B561JS	R METAL FILM	2W 560 OHM J SMALL	
RP04	RN02B753JS	R METAL FILM	2W 75K OHM J SMALL	
RP05	RN02B333JS	R METAL FILM	2W 33K OHM J SMALL	
RP14	RN01B124JS	R METAL FILM	1W 120K OHM J SMALL	
X502	5XEX5R000E	CRYSTAL QUARTZ	HC-49U 5.000MHZ 30PPM	
X701	5XEX6R000C	CRYSTAL QUARTZ	HC-49U 6.000M 20PPM TP	
Z601	5PXF1B471M	FILTER EMI	CFI 06 B 1H 470PF	
Z602	5PXF1B471M	FILTER EMI	CFI 06 B 1H 470PF	
Z603	5PXF1B471M	FILTER EMI	CFI 06 B 1H 470PF	
Z604	5PXF1B471M	FILTER EMI	CFI 06 B 1H 470PF	
Z605	5PXF1B471M	FILTER EMI	CFI 06 B 1H 470PF	
Z606	5PXF1B471M	FILTER EMI	CFI 06 B 1H 470PF	
Z607	5PXF1B471M	FILTER EMI	CFI 06 B 1H 470PF	
Z608	5PXF1B471M	FILTER EMI	CFI 06 B 1H 470PF	
ZZ200	PTMPJAT2950FS	PCB MAIN AXIAL AS	DTF-2950FZS-SB	
10	2TM14006LB	TAPE MASKING	3M #232 6.0X2000M (WITH GLUE)	
20	2TM10006LB	TAPE MASKING	3M #232-MAP-C 6.2X2000M (W/O GLUE)	
A001	4859812993	PCB MAIN	CP-850FX DTF-2950 (330X246 D1B)	▲
C101	CCZB1H101K	C CERA	50V B 100PF K (AXIAL)	
C111	CCZJ1H103Z	C CERA	50V F 0.01MF Z AXL (1608)	
C112	CCZB1H102K	C CERA	50V B 1000PF K (AXIAL)	
C161	CZCH1H220J	C CERA	50V CH 22PF J (AXIAL)	
C414	CCZJ1H103Z	C CERA	50V F 0.01MF Z AXL (1608)	
C440	CCZB1H221K	C CERA	50V B 220PF K (AXIAL)	
C508	CCZJ1H473Z	C CERA	50V F 0.047MF Z AXL (1608)	
C509	CCZJ1H473Z	C CERA	50V F 0.047MF Z AXL (1608)	
C510	CCZJ1H473Z	C CERA	50V F 0.047MF Z AXL (1608)	
C515	CCZJ1H104Z	C CERA	50V F 0.1MF Z AXL (1608)	
C516	CCZJ1H104Z	C CERA	50V F 0.1MF Z AXL (1608)	
C517	CCZJ1H104Z	C CERA	50V F 0.1MF Z AXL (1608)	
C518	CCZJ1H104Z	C CERA	50V F 0.1MF Z AXL (1608)	
C519	CCZJ1H104Z	C CERA	50V F 0.1MF Z AXL (1608)	
C532	CCZJ1H103Z	C CERA	50V F 0.01MF Z AXL (1608)	
C534	CCZJ1H103Z	C CERA	50V F 0.01MF Z AXL (1608)	
C536	CCZB1H102K	C CERA	50V B 1000PF K (AXIAL)	
C537	CCZJ1H103Z	C CERA	50V F 0.01MF Z AXL (1608)	
C538	CCZJ1H103Z	C CERA	50V F 0.01MF Z AXL (1608)	
C540	CCZL1H333K	C CERA	50V B 0.033MF K AXL (1608)	
C553	CCZJ1H103Z	C CERA	50V F 0.01MF Z AXL (1608)	
C557	CCZJ1H104Z	C CERA	50V F 0.1MF Z AXL (1608)	
C558	CCZJ1H104Z	C CERA	50V F 0.1MF Z AXL (1608)	
C650	CZSL1H680J	C CERA	50V SL 68PF J (AXIAL)	
C712	CCZJ1H104Z	C CERA	50V F 0.1MF Z AXL (1608)	
C809	CCZB1H102K	C CERA	50V B 1000PF K (AXIAL)	
C834	CCZJ1H103Z	C CERA	50V F 0.01MF Z AXL (1608)	
D100	DTZX33B—	DIODE ZENER	TZX33B (TAPPING)	
D101	DBAT85—	DIODE	BAT85 (TAPPING)	
D103	DBA282—	DIODE	BA282	
D313	DRGP15J—	DIODE	RG15J	
D367	DTZX33B—	DIODE ZENER	TZX33B (TAPPING)	
D405	D1N4937G—	DIODE	1N4937G	
D408	D1N4937G—	DIODE	1N4937G	

LOC	PART CODE	PART NAME	DESCRIPTION	REMARK
D410	D1N4937G—	DIODE	1N4937G	
D414	D1N4004S—	DIODE	1N4004S	
D415	D1N4937G—	DIODE	1N4937G	
D530	D1N4148—	DIODE	1N4148 (TAPPING)	
D531	D1N4148—	DIODE	1N4148 (TAPPING)	
D535	D1N4148—	DIODE	1N4148 (TAPPING)	
D540	D1N4148—	DIODE	1N4148 (TAPPING)	
D541	D1N4148—	DIODE	1N4148 (TAPPING)	
D550	D1N4148—	DIODE	1N4148 (TAPPING)	
D551	D1N4148—	DIODE	1N4148 (TAPPING)	
D602	D1N4148—	DIODE	1N4148 (TAPPING)	
D603	D1N4148—	DIODE	1N4148 (TAPPING)	
D701	D1N4148—	DIODE	1N4148 (TAPPING)	
D702	D1N4148—	DIODE	1N4148 (TAPPING)	
D720	DTZX2V7A—	DIODE ZENER	TZX2V7A (TAPPING)	
D730	DTZX7V5C—	DIODE ZENER	TZX7V5C (TAPPING)	
D777	DTZX5V6B—	DIODE ZENER	TZX5V6B (TAPPING)	
D801	DLT2A05G—	DIODE	LT2A05G	
D802	DLT2A05G—	DIODE	LT2A05G	
D803	DLT2A05G—	DIODE	LT2A05G	
D804	DLT2A05G—	DIODE	LT2A05G	
D805	D1N4148—	DIODE	1N4148 (TAPPING)	
D806	D1N4937G—	DIODE	1N4937G	
D807	D1N4937G—	DIODE	1N4937G	
D808	DTX6V2—	DIODE ZENER	TX6V2B (TAPPING)	
D811	DTZX7V5C—	DIODE ZENER	TZX7V5C (TAPPING)	
D825	D1N4148—	DIODE	1N4148 (TAPPING)	
D826	DTZX5V1B—	DIODE ZENER	TZX5V1B (TAPPING)	
D827	D1N4004S—	DIODE	1N4004S	
D830	DRGP15J—	DIODE	RG15J	
D831	DRGP15J—	DIODE	RG15J	
D871	D1N4937G—	DIODE	1N4937G	
D899	DRGP15J—	DIODE	RG15J	
DA11	DTZX5V6B—	DIODE ZENER	TZX5V6B (TAPPING)	
DA13	DTZX5V6B—	DIODE ZENER	TZX5V6B (TAPPING)	
DA16	DTZX5V6B—	DIODE ZENER	TZX5V6B (TAPPING)	
DA17	DTZX5V6B—	DIODE ZENER	TZX5V6B (TAPPING)	
DA27	DTZX5V6B—	DIODE ZENER	TZX5V6B (TAPPING)	
DP02	D1N4148—	DIODE	1N4148 (TAPPING)	
DP03	D1N4148—	DIODE	1N4148 (TAPPING)	
DP04	DTZX12C—	DIODE ZENER	TZX12C (TAPPING)	
DP05	DTZX8V2A—	DIODE ZENER	TZX8V2A (TAPPING)	
DP06	D1N4148—	DIODE	1N4148 (TAPPING)	
DP08	D1N4148—	DIODE	1N4148 (TAPPING)	
J1	85801060GY	WIRE COPPER	1/0.6 TIN COATING	
J112	85801060GY	WIRE COPPER	1/0.6 TIN COATING	
J113	85801060GY	WIRE COPPER	1/0.6 TIN COATING	
J114	85801060GY	WIRE COPPER	1/0.6 TIN COATING	
J115	85801060GY	WIRE COPPER	1/0.6 TIN COATING	
J125	85801060GY	WIRE COPPER	1/0.6 TIN COATING	
J128	85801060GY	WIRE COPPER	1/0.6 TIN COATING	
J135	85801060GY	WIRE COPPER	1/0.6 TIN COATING	
J143	85801060GY	WIRE COPPER	1/0.6 TIN COATING	
J156	85801060GY	WIRE COPPER	1/0.6 TIN COATING	
J2	85801060GY	WIRE COPPER	1/0.6 TIN COATING	
J201	85801060GY	WIRE COPPER	1/0.6 TIN COATING	
J232	85801060GY	WIRE COPPER	1/0.6 TIN COATING	
J234	85801060GY	WIRE COPPER	1/0.6 TIN COATING	
J235	85801060GY	WIRE COPPER	1/0.6 TIN COATING	
J236	85801060GY	WIRE COPPER	1/0.6 TIN COATING	
J240	85801060GY	WIRE COPPER	1/0.6 TIN COATING	
J243	85801060GY	WIRE COPPER	1/0.6 TIN COATING	
J276	85801060GY	WIRE COPPER	1/0.6 TIN COATING	
J278	85801060GY	WIRE COPPER	1/0.6 TIN COATING	
J28	85801060GY	WIRE COPPER	1/0.6 TIN COATING	
J287	85801060GY	WIRE COPPER	1/0.6 TIN COATING	
J289	85801060GY	WIRE COPPER	1/0.6 TIN COATING	
J30	85801060GY	WIRE COPPER	1/0.6 TIN COATING	

CP-850FX Service Manual

LOC	PART CODE	PART NAME	DESCRIPTION	REMARK
L601	5CPZ479K02	COIL PEAKING	4.7UH 3.5MM K (LAL02TB)	
L602	5CPZ100K02	COIL PEAKING	10UH 3.5MM K (LAL02TB)	
L603	5CPZ479K02	COIL PEAKING	4.7UH 3.5MM K (LAL02TB)	
L605	5CPZ479K02	COIL PEAKING	4.7UH 3.5MM K (LAL02TB)	
L650	5MC0000100	COIL BEAD	MD-5 (HC-3550)	
L709	5CPZ100K02	COIL PEAKING	10UH 3.5MM K (LAL02TB)	
L711	5CPZ100K02	COIL PEAKING	10UH 3.5MM K (LAL02TB)	
L713	5CPZ100K02	COIL PEAKING	10UH 3.5MM K (LAL02TB)	
L730	5CPZ100K02	COIL PEAKING	10UH 3.5MM K (LAL02TB)	
L737	5CPZ100K02	COIL PEAKING	10UH 3.5MM K (LAL02TB)	
L742	5CPZ100K02	COIL PEAKING	10UH 3.5MM K (LAL02TB)	
L744	5CPZ100K02	COIL PEAKING	10UH 3.5MM K (LAL02TB)	
L801	5MC0000100	COIL BEAD	MD-5 (HC-3550)	
R103	RD-AZ123J	R CARBON FILM	1/6 12K OHM J	
R110	RN-4Z1502F	R METAL FILM	1/4 15K OHM F	
R150	RD-AZ561J	R CARBON FILM	1/6 560 OHM J	
R152	RD-AZ271J	R CARBON FILM	1/6 270 OHM J	
R153	RD-AZ470J	R CARBON FILM	1/6 47 OHM J	
R154	RD-AZ470J	R CARBON FILM	1/6 47 OHM J	
R155	RD-AZ751J	R CARBON FILM	1/6 750 OHM J	
R161	RD-AZ102J	R CARBON FILM	1/6 1K OHM J	
R162	RD-AZ153J	R CARBON FILM	1/6 15K OHM J	
R163	RD-AZ752J	R CARBON FILM	1/6 7.5K OHM J	
R177	RD-AZ562J	R CARBON FILM	1/6 5.6K OHM J	
R301	RD-AZ472J	R CARBON FILM	1/4 4.7K OHM J	
R310	RD-AZ432J	R CARBON FILM	1/6 4.3K OHM J	
R311	RD-AZ432J	R CARBON FILM	1/6 4.3K OHM J	
R333	RD-AZ222J	R CARBON FILM	1/6 2.2K OHM J	
R334	RD-AZ222J	R CARBON FILM	1/6 2.2K OHM J	
R340	85801060GY	WIRE COPPER	1/0.6 TIN COATING	
R341	85801060GY	WIRE COPPER	1/0.6 TIN COATING	
R345	RD-4Z473J	R CARBON FILM	1/4 47K OHM J	
R350	RN-AZ2201F	R METAL FILM	1/6 2.2K OHM F	
R351	RN-AZ2201F	R METAL FILM	1/6 2.2K OHM F	
R394	RD-AZ272J	R CARBON FILM	1/6 2.7K OHM J	
R395	RD-4Z754J	R CARBON FILM	1/4 750K OHM J	
R396	RD-AZ272J	R CARBON FILM	1/6 2.7K OHM J	
R397	RD-AZ104J	R CARBON FILM	1/6 100K OHM J	
R414	RD-AZ681J	R CARBON FILM	1/6 680 OHM J	
R420	RD-AZ471J	R CARBON FILM	1/6 470 OHM J	
R424	RD-AZ472J	R CARBON FILM	1/4 4.7K OHM J	
R430	RD-4Z103J	R CARBON FILM	1/4 10K OHM J	
R440	RD-AZ274J	R CARBON FILM	1/4 270K OHM J	
R501	RD-AZ101J	R CARBON FILM	1/6 100 OHM J	
R502	RD-AZ101J	R CARBON FILM	1/6 100 OHM J	
R504	RD-AZ102J	R CARBON FILM	1/6 1K OHM J	
R507	RD-AZ562J	R CARBON FILM	1/6 5.6K OHM J	
R510	RD-AZ101J	R CARBON FILM	1/6 100 OHM J	
R511	RD-AZ330J	R CARBON FILM	1/6 33 OHM J	
R512	RD-AZ330J	R CARBON FILM	1/6 33 OHM J	
R513	RD-AZ330J	R CARBON FILM	1/6 33 OHM J	
R514	RD-AZ151J	R CARBON FILM	1/6 150 OHM J	
R515	RD-AZ223J	R CARBON FILM	1/6 22K OHM J	
R516	RD-AZ752J	R CARBON FILM	1/6 7.5K OHM J	
R517	RD-AZ471J	R CARBON FILM	1/6 470 OHM J	
R518	RD-AZ750J	R CARBON FILM	1/6 75 OHM J	
R519	RD-AZ750J	R CARBON FILM	1/6 75 OHM J	
R520	RD-AZ750J	R CARBON FILM	1/6 75 OHM J	
R524	RD-AZ391J	R CARBON FILM	1/6 390 OHM J	
R525	RD-AZ101J	R CARBON FILM	1/6 100 OHM J	
R533	RD-AZ392J	R CARBON FILM	1/6 3.9K OHM J	
R534	RD-AZ391J	R CARBON FILM	1/6 390 OHM J	
R535	RD-AZ122J	R CARBON FILM	1/6 1.2K OHM J	
R537	RD-AZ301J	R CARBON FILM	1/6 300 OHM J	
R538	RD-AZ301J	R CARBON FILM	1/6 300 OHM J	
R540	RD-AZ472J	R CARBON FILM	1/6 4.7K OHM J	
R545	RD-AZ750J	R CARBON FILM	1/6 75 OHM J	
R550	RD-AZ102J	R CARBON FILM	1/6 1K OHM J	

LOC	PART CODE	PART NAME	DESCRIPTION	REMARK
R551	RD-AZ471J	R CARBON FILM	1/6 470 OHM J	
R563	RD-AZ101J	R CARBON FILM	1/6 100 OHM J	
R564	RD-AZ101J	R CARBON FILM	1/6 100 OHM J	
R566	RD-AZ220J	R CARBON FILM	1/6 22 OHM J	
R570	RD-AZ271J	R CARBON FILM	1/6 270 OHM J	
R576	RD-AZ151J	R CARBON FILM	1/6 150 OHM J	
R580	RD-AZ101J	R CARBON FILM	1/6 100 OHM J	
R588	RD-AZ101J	R CARBON FILM	1/6 100 OHM J	
R590	RD-AZ102J	R CARBON FILM	1/6 1K OHM J	
R593	RD-AZ203J	R CARBON FILM	1/6 20K OHM J	
R594	RD-AZ101J	R CARBON FILM	1/6 100 OHM J	
R595	RD-AZ101J	R CARBON FILM	1/6 100 OHM J	
R599	RD-AZ151J	R CARBON FILM	1/6 150 OHM J	
R602	RD-AZ104J	R CARBON FILM	1/6 100K OHM J	
R605	RD-AZ101J	R CARBON FILM	1/6 100 OHM J	
R606	RD-AZ101J	R CARBON FILM	1/6 100 OHM J	
R610	RD-AZ682J	R CARBON FILM	1/6 6.8K OHM J	
R612	RD-AZ474J	R CARBON FILM	1/6 470K OHM J	
R613	RD-AZ473J	R CARBON FILM	1/6 47K OHM J	
R614	RD-AZ102J	R CARBON FILM	1/6 1K OHM J	
R615	RD-AZ102J	R CARBON FILM	1/6 1K OHM J	
R616	RD-AZ103J	R CARBON FILM	1/6 10K OHM J	
R620	RD-AZ242J	R CARBON FILM	1/6 2.4K OHM J	
R621	RD-AZ102J	R CARBON FILM	1/6 1K OHM J	
R622	RD-AZ102J	R CARBON FILM	1/6 1K OHM J	
R641	RD-AZ102J	R CARBON FILM	1/6 1K OHM J	
R642	RD-AZ102J	R CARBON FILM	1/6 1K OHM J	
R646	RD-AZ102J	R CARBON FILM	1/6 1K OHM J	
R647	RD-AZ102J	R CARBON FILM	1/6 1K OHM J	
R649	RD-AZ102J	R CARBON FILM	1/6 1K OHM J	
R650	RD-AZ362J	R CARBON FILM	1/6 3.6K OHM J	
R651	RD-AZ102J	R CARBON FILM	1/6 1K OHM J	
R652	RD-AZ102J	R CARBON FILM	1/6 1K OHM J	
R660	RD-AZ362J	R CARBON FILM	1/6 3.6K OHM J	
R680	RD-AZ152J	R CARBON FILM	1/6 1.5K OHM J	
R700	RD-2Z332J	R CARBON FILM	1/2 3.3K OHM J	
R701	RD-AZ472J	R CARBON FILM	1/6 4.7K OHM J	
R702	RD-AZ102J	R CARBON FILM	1/6 1K OHM J	
R703	RD-AZ101J	R CARBON FILM	1/6 100 OHM J	
R704	RD-AZ101J	R CARBON FILM	1/6 100 OHM J	
R709	RD-AZ472J	R CARBON FILM	1/6 4.7K OHM J	
R720	RD-AZ681J	R CARBON FILM	1/6 680 OHM J	
R741	RD-AZ101J	R CARBON FILM	1/6 100 OHM J	
R748	RD-AZ101J	R CARBON FILM	1/6 100 OHM J	
R777	RD-AZ750J	R CARBON FILM	1/6 75 OHM J	
R781	RD-AZ332J	R CARBON FILM	1/6 3.3K OHM J	
R788	RD-AZ103J	R CARBON FILM	1/6 10K OHM J	
R789	RD-AZ103J	R CARBON FILM	1/6 10K OHM J	
R790	RD-AZ512J	R CARBON FILM	1/6 5.1K OHM J	
R804	RD-4Z479J	R CARBON FILM	1/4 4.7K OHM J	
R805	RD-2Z104J	R CARBON FILM	1/2 100K OHM J	
R807	RD-AZ221J	R CARBON FILM	1/4 220 OHM J	
R808	RD-4Z182J	R CARBON FILM	1/4 1.8K OHM J	
R809	RD-AZ102J	R CARBON FILM	1/4 1K OHM J	
R810	RD-AZ220J	R CARBON FILM	1/4 22 OHM J	
R811	RC-2Z565KP	R CARBON COMP	1/2 5.6M OHM K	△
R817	RD-AZ473J	R CARBON FILM	1/6 47K OHM J	
R818	RD-AZ683J	R CARBON FILM	1/6 68K OHM J	
R820	RD-4Z363J	R CARBON FILM	1/4 36K OHM J	
R821	RD-AZ563J	R CARBON FILM	1/6 56K OHM J	
R823	RD-AZ332J	R CARBON FILM	1/4 3.3K OHM J	
R827	RD-AZ103J	R CARBON FILM	1/6 10K OHM J	
R828	RD-4Z153J	R CARBON FILM	1/4 15K OHM J	
R829	RD-AZ103J	R CARBON FILM	1/6 10K OHM J	
R830	RD-AZ101J	R CARBON FILM	1/6 100 OHM J	
R831	RD-AZ472J	R CARBON FILM	1/6 4.7K OHM J	
R832	RD-AZ473J	R CARBON FILM	1/6 47K OHM J	

LOC	PART CODE	PART NAME	DESCRIPTION	REMARK
R834	RD-4Z470J	R CARBON FILM	1/4 47 OHM J	
R870	RD-4Z102J	R CARBON FILM	1/4 1K OHM J	
R883	RD-AZ103J	R CARBON FILM	1/6 10K OHM J	
R884	RD-AZ103J	R CARBON FILM	1/6 10K OHM J	
RA01	RD-AZ220J	R CARBON FILM	1/6 22 OHM J	
RA10	RD-AZ103J	R CARBON FILM	1/6 10K OHM J	
RA13	RD-AZ332J	R CARBON FILM	1/6 3.3K OHM J	
RA15	RD-AZ680J	R CARBON FILM	1/6 68 OHM J	
RA16	RD-AZ750J	R CARBON FILM	1/6 75 OHM J	
RA32	85801060GY	WIRE COPPER	1/0.6 TIN COATING	
RA35	RD-AZ750J	R CARBON FILM	1/6 75 OHM J	
RA88	RD-AZ750J	R CARBON FILM	1/6 75 OHM J	
RP03	RD-4Z102J	R CARBON FILM	1/4 1K OHM J	
RP06	RD-4Z472J	R CARBON FILM	1/4 4.7K OHM J	
RP08	RD-4Z361J	R CARBON FILM	1/4 360 OHM J	
RP10	RD-2Z472J	R CARBON FILM	1/2 4.7K OHM J	
RP12	RD-4Z470J	R CARBON FILM	1/4 47 OHM J	
RP13	RD-2Z101J	R CARBON FILM	1/2 100 OHM J	
ZZ400	PTCPMST2950FS	PCB CRT MANUAL AS	DTF-2950FZS-SB	
C900	CCXB3D102K	C CERA	2KV B 1000 PF K (TAPPING)	
C910	CEXF2E479V	C ELECTRO	250V RSS 4.7MF (10X16)TP	
C997	CEXF2E100V	C ELECTRO	250V RSS 10MF (10X20) TP	
I901	1TDA6108JF	IC VIDEO	TD46108JF	
I901A	4857025401	HEAT SINK	A1050P-H24 T2	
I901B	7174300851	SCREW TAPPITTE	TT2 RND 3X8 MFZN 3CR	
P401A	4859231820	CONN WAFER	YW025-05	
P501A	4859235120	CONN WAFER	YW025-08	
P903	4859238620	CONN WAFER	YPW500-02	
R906	RF02Y629J	R FUSIBLE	2W 6.2 OHM J	
SCT1	4859304130	SOCKET CRT	ISHG93S	△
ZZ200	PTCPJRT2950FS	PCB CRT RADIAL AS	DTF-2950FZS-SB	
C902	CMXL2E104K	C MYLAR	250V 0.1MF K MEU TP	
C921	CMXM2A102J	C MYLAR	100V 1000PF J TP	
C922	CMXM2A102J	C MYLAR	100V 1000PF J TP	
C923	CMXM2A102J	C MYLAR	100V 1000PF J TP	
G900	4SG0DX0001	SPARK GAP	SSG-102-A1 (1.0KV)	
G901	4SG0DX0001	SPARK GAP	SSG-102-A1 (1.0KV)	
G902	4SG0DX0001	SPARK GAP	SSG-102-A1 (1.0KV)	
G903	4SG0DX0001	SPARK GAP	SSG-102-A1 (1.0KV)	
Q921	TBF423—	TR	BF423 TO-92	
Q922	TBF423—	TR	BF423 TO-92	
Q923	TBF423—	TR	BF423 TO-92	
R905	RN02B102JS	R METAL FILM	2W 1K OHM J SMALL	
ZZ200	PTCPJAT2950FS	PCB CRT AXIAL AS	DTF-2950FZS-SB	
A001	4859829013	PCB CRT	CP-830/830F (DTG/DTH)	△
D911	D1N4004S—	DIODE	1N4004S	
D912	D1N4004S—	DIODE	1N4004S	
D913	D1N4004S—	DIODE	1N4004S	
D921	D1N4004S—	DIODE	1N4004S	
D922	D1N4004S—	DIODE	1N4004S	
D923	D1N4004S—	DIODE	1N4004S	
D997	DLT2A05G—	DIODE	LT2A05G	
R901	RD-AZ101J	R CARBON FILM	1/6 100 OHM J	
R902	RD-AZ101J	R CARBON FILM	1/6 100 OHM J	
R903	RD-AZ101J	R CARBON FILM	1/6 100 OHM J	
R911	RD-AZ101J	R CARBON FILM	1/6 100 OHM J	
R912	RD-AZ101J	R CARBON FILM	1/6 100 OHM J	
R913	RD-AZ101J	R CARBON FILM	1/6 100 OHM J	
R921	RC-2Z102K-	R CARBON COMP	1/2 1K OHM K	
R922	RC-2Z102K-	R CARBON COMP	1/2 1K OHM K	
R923	RC-2Z102K-	R CARBON COMP	1/2 1K OHM K	
R931	RD-AZ102J	R CARBON FILM	1/6 1K OHM J	
R932	RD-AZ102J	R CARBON FILM	1/6 1K OHM J	
R933	RD-AZ102J	R CARBON FILM	1/6 1K OHM J	
R996	RD-2Z105J	R CARBON FILM	1/2 1M OHM J	
R997	RD-2Z102J	R CARBON FILM	1/2 1K OHM J	
ZZ140	PTPKCPF2930F	PACKING AS	DTF-2930FZS-SB	

LOC	PART CODE	PART NAME	DESCRIPTION	REMARK
10	6520010200	STAPLE PIN	#3417 ALL	
M681	2TP06575CL	TAPE OPP	T0.065XW75X500M CLEAR	
M801	DMP5018800	BOX	DTL-2950 (NEW)	
M811	485819D500DN	PAD DOWN	2930 EPS	
M811A	485819D500UP	PAD UP	2930 EPS	
M821	4858215601	BAG P.E.	*PE FOAM T0.5X1600X1270 25"-28"	

7. EXPLODED VIEW

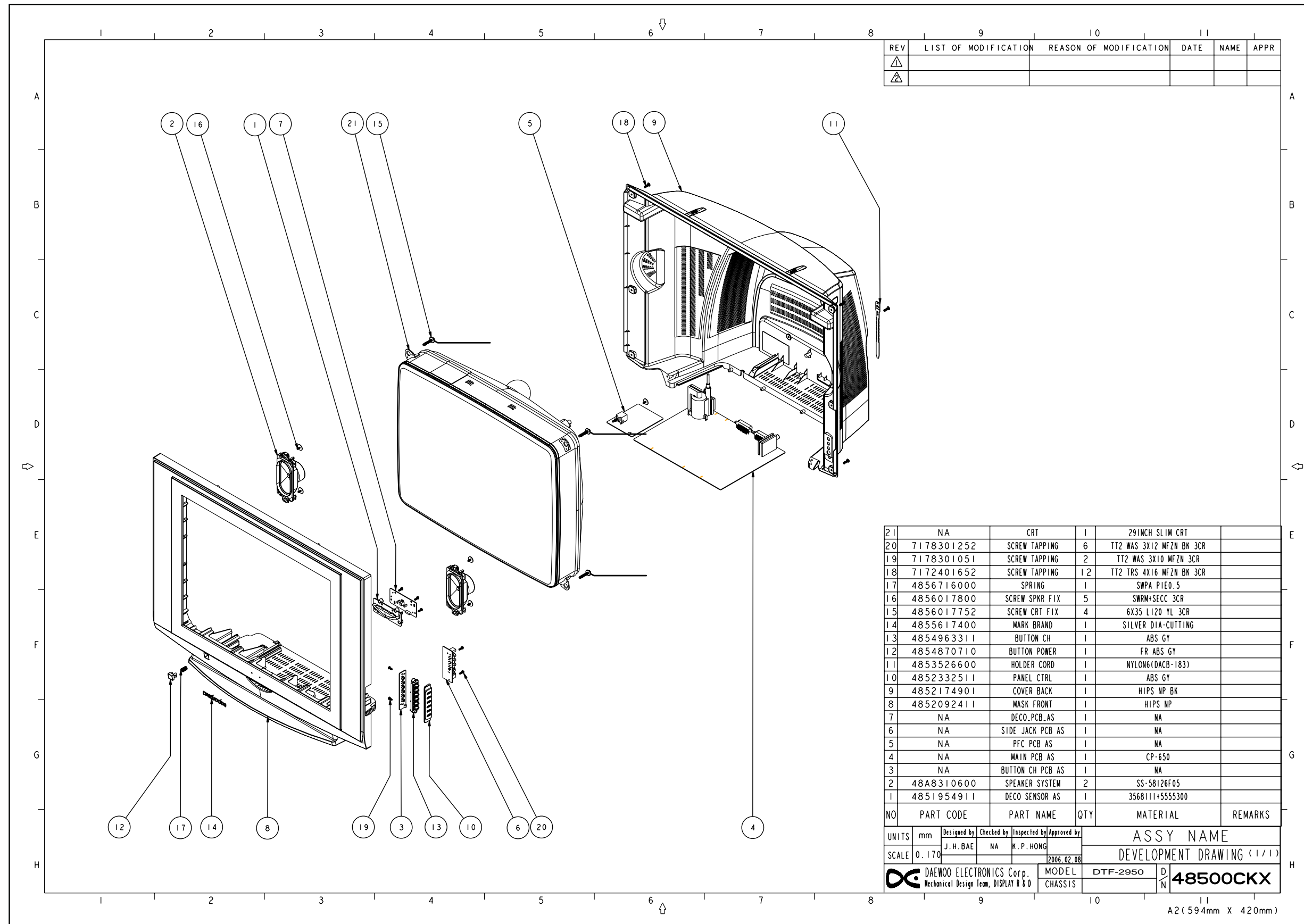

REV	LIST OF MODIFICATION	REASON OF MODIFICATION	DATE	NAME	APPR
△					
△					

21	NA	CRT	1	29INCH SLIM CRT	
20	7178301252	SCREW TAPPING	6	TT2 WAS 3X12 MFZN BK 3CR	
19	7178301051	SCREW TAPPING	2	TT2 WAS 3X10 MFZN 3CR	
18	7172401652	SCREW TAPPING	12	TT2 TRS 4X16 MFZN BK 3CR	
17	4856716000	SPRING	1	SWPA PIE0.5	
16	4856017800	SCREW SPKR FIX	5	SWRM+SECC 3CR	
15	4856017752	SCREW CRT FIX	4	6X35 L120 YL 3CR	
14	4855617400	MARK BRAND	1	SILVER DIA-CUTTING	
13	4854963311	BUTTON CH	1	ABS GY	
12	4854870710	BUTTON POWER	1	FR ABS GY	
11	4853526600	HOLDER CORD	1	NYLON6(DACB-183)	
10	4852332511	PANEL CTRL	1	ABS GY	
9	4852174901	COVER BACK	1	HIPS NP BK	
8	4852092411	MASK FRONT	1	HIPS NP	
7	NA	DECO_PCB_AS	1	NA	
6	NA	SIDE JACK PCB AS	1	NA	
5	NA	PFC PCB AS	1	NA	
4	NA	MAIN PCB AS	1	CP-650	
3	NA	BUTTON CH PCB AS	1	NA	
2	48A8310600	SPEAKER SYSTEM	2	SS-58126F05	
1	4851954911	DECO SENSOR AS	1	3568111+5555300	
NO	PART CODE	PART NAME	QTY	MATERIAL	REMARKS

UNITS	mm	Designed by	Checked by	Inspected by	Approved by	ASSY NAME DEVELOPMENT DRAWING (1/1)
SCALE	0.170	J. H. BAE	NA	K. P. HONG	2006.02.08	
DAEWOO ELECTRONICS Corp.		MODEL		DTF-2950	D N 48500CKX	
Mechanical Design Team, DISPLAY R & D		CHASSIS				

A2(594mm X 420mm)

EXPLODED VIEW

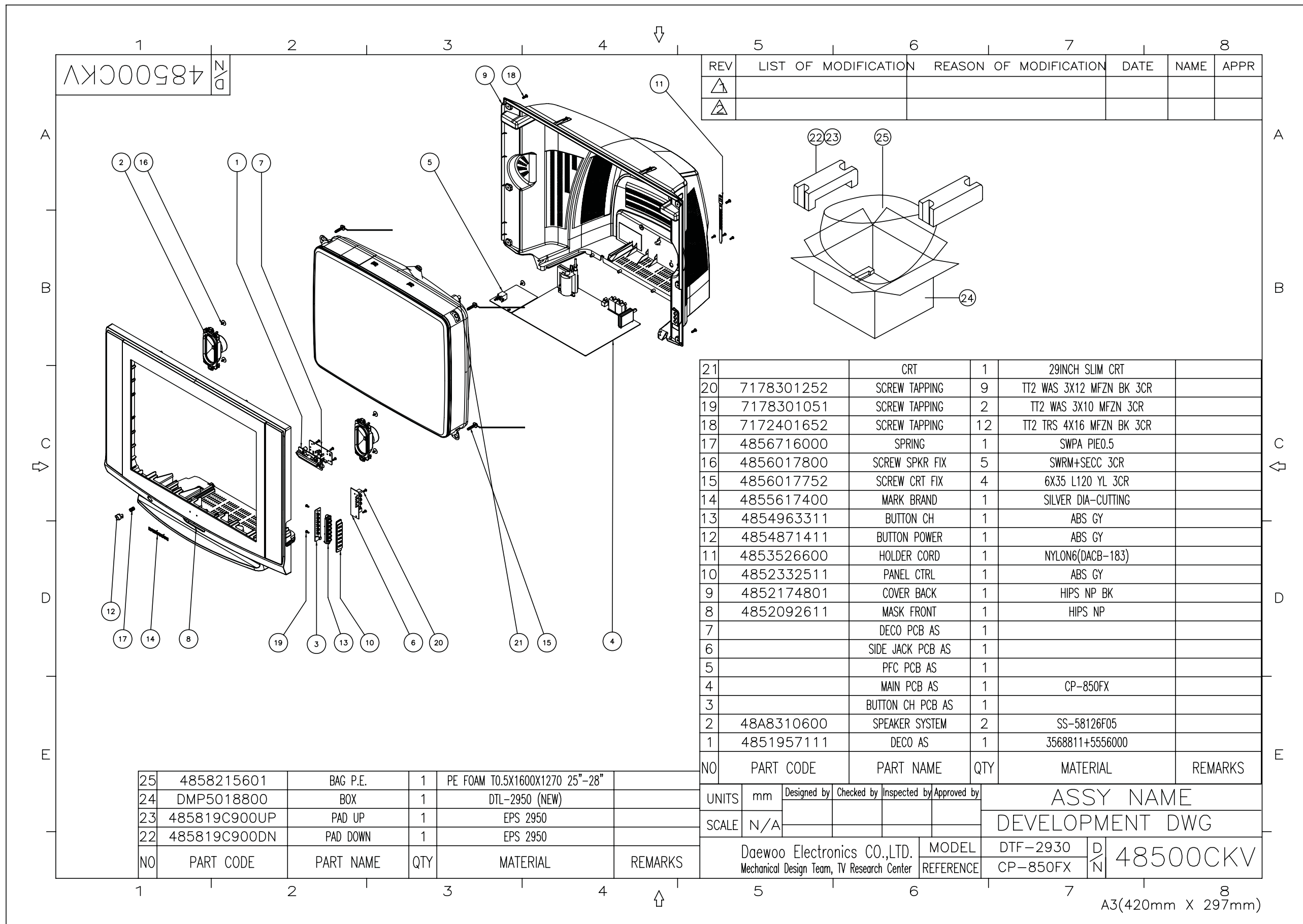

REV	LIST OF MODIFICATION	REASON OF MODIFICATION	DATE	NAME	APPR
△					
△					

21		CRT	1	29INCH SLIM CRT	
20	7178301252	SCREW TAPPING	9	TT2 WAS 3X12 MFZN BK 3CR	
19	7178301051	SCREW TAPPING	2	TT2 WAS 3X10 MFZN 3CR	
18	7172401652	SCREW TAPPING	12	TT2 TRS 4X16 MFZN BK 3CR	
17	4856716000	SPRING	1	SWPA PIE0.5	
16	4856017800	SCREW SPKR FIX	5	SWRM+SECC 3CR	
15	4856017752	SCREW CRT FIX	4	6X35 L120 YL 3CR	
14	4855617400	MARK BRAND	1	SILVER DIA-CUTTING	
13	4854963311	BUTTON CH	1	ABS GY	
12	4854871411	BUTTON POWER	1	ABS GY	
11	4853526600	HOLDER CORD	1	NYLONG(DACB-183)	
10	4852332511	PANEL CTRL	1	ABS GY	
9	4852174801	COVER BACK	1	HIPS NP BK	
8	4852092611	MASK FRONT	1	HIPS NP	
7		DECO PCB AS	1		
6		SIDE JACK PCB AS	1		
5		PFC PCB AS	1		
4		MAIN PCB AS	1	CP-850FX	
3		BUTTON CH PCB AS	1		
2	48A8310600	SPEAKER SYSTEM	2	SS-58126F05	
1	4851957111	DECO AS	1	3568811+5556000	
NO	PART CODE	PART NAME	QTY	MATERIAL	REMARKS

25	4858215601	BAG P.E.	1	PE FOAM T0.5X1600X1270 25"-28"	
24	DMP5018800	BOX	1	DTL-2950 (NEW)	
23	485819C900UP	PAD UP	1	EPS 2950	
22	485819C900DN	PAD DOWN	1	EPS 2950	
NO	PART CODE	PART NAME	QTY	MATERIAL	REMARKS

UNITS	mm	Designed by	Checked by	Inspected by	Approved by	ASSY NAME	
SCALE	N/A					DEVELOPMENT DWG	
		Daewoo Electronics CO.,LTD.	MODEL	DTF-2930	D/N	48500CKV	
		Mechanical Design Team, TV Research Center	REFERENCE	CP-850FX			

A3(420mm X 297mm)

8. PRINTED CIRCUIT BOARD

8.1 MAIN PCB

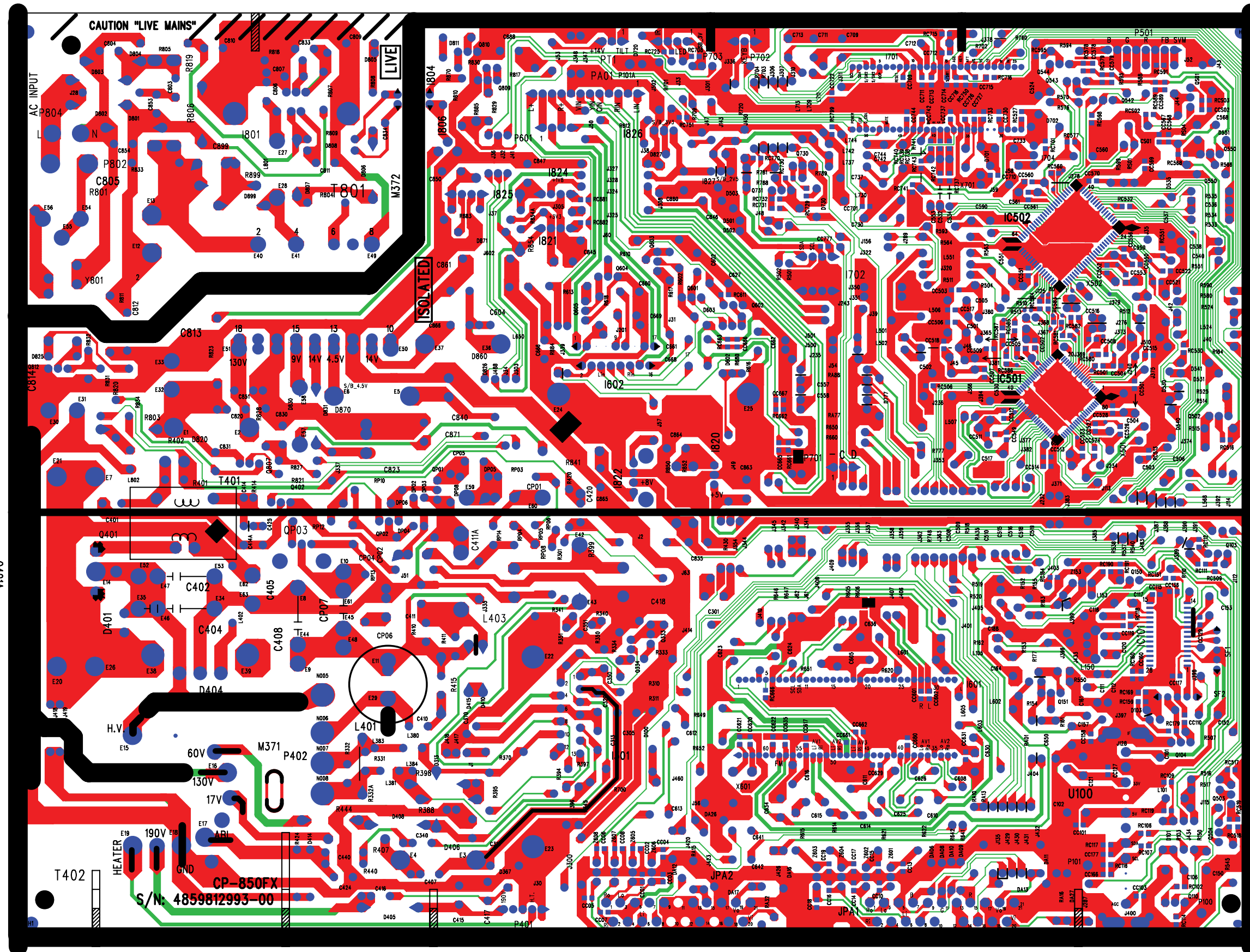

PRINTED CIRCUIT BOARD

8.2 UNION PCB

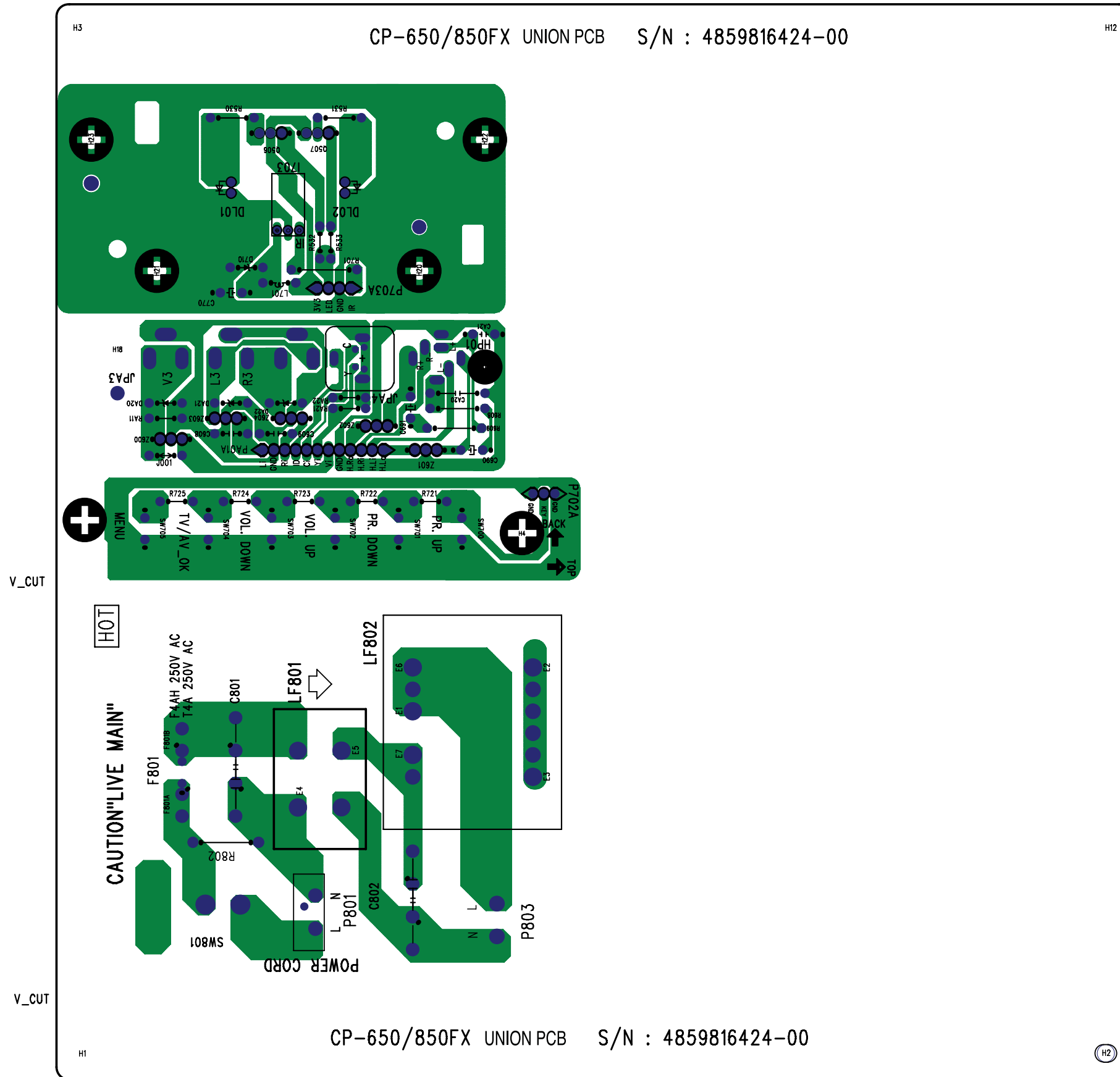

PRINTED CIRCUIT BOARD

8.3 CRT PCB

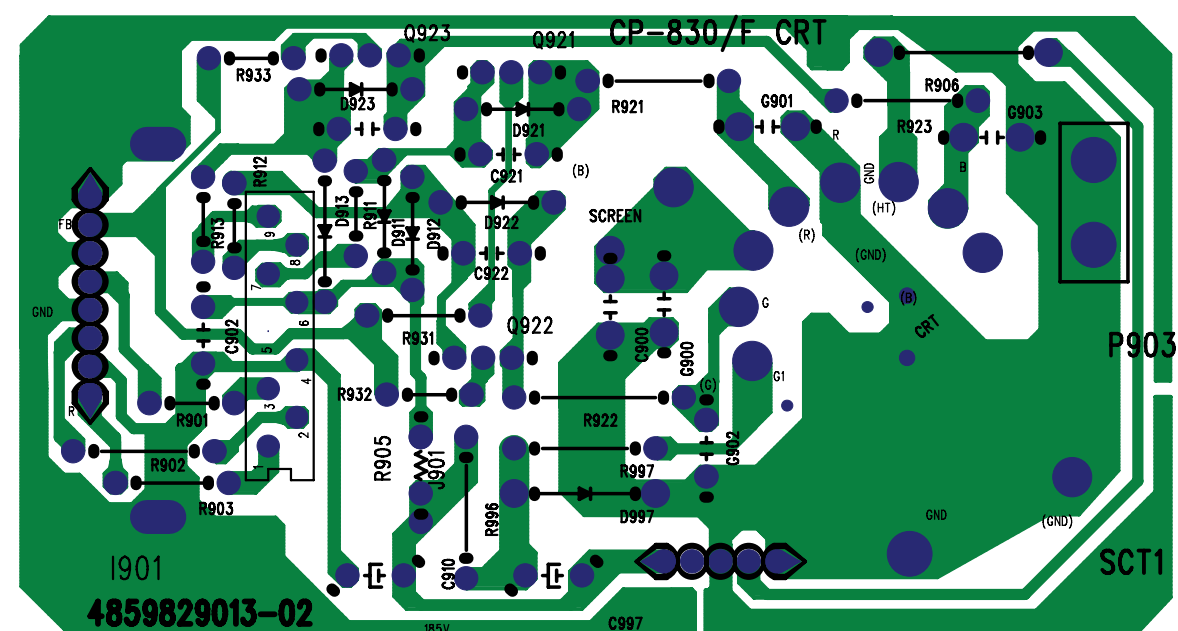

9. SCHEMATIC DIAGRAM

9.1 MAIN

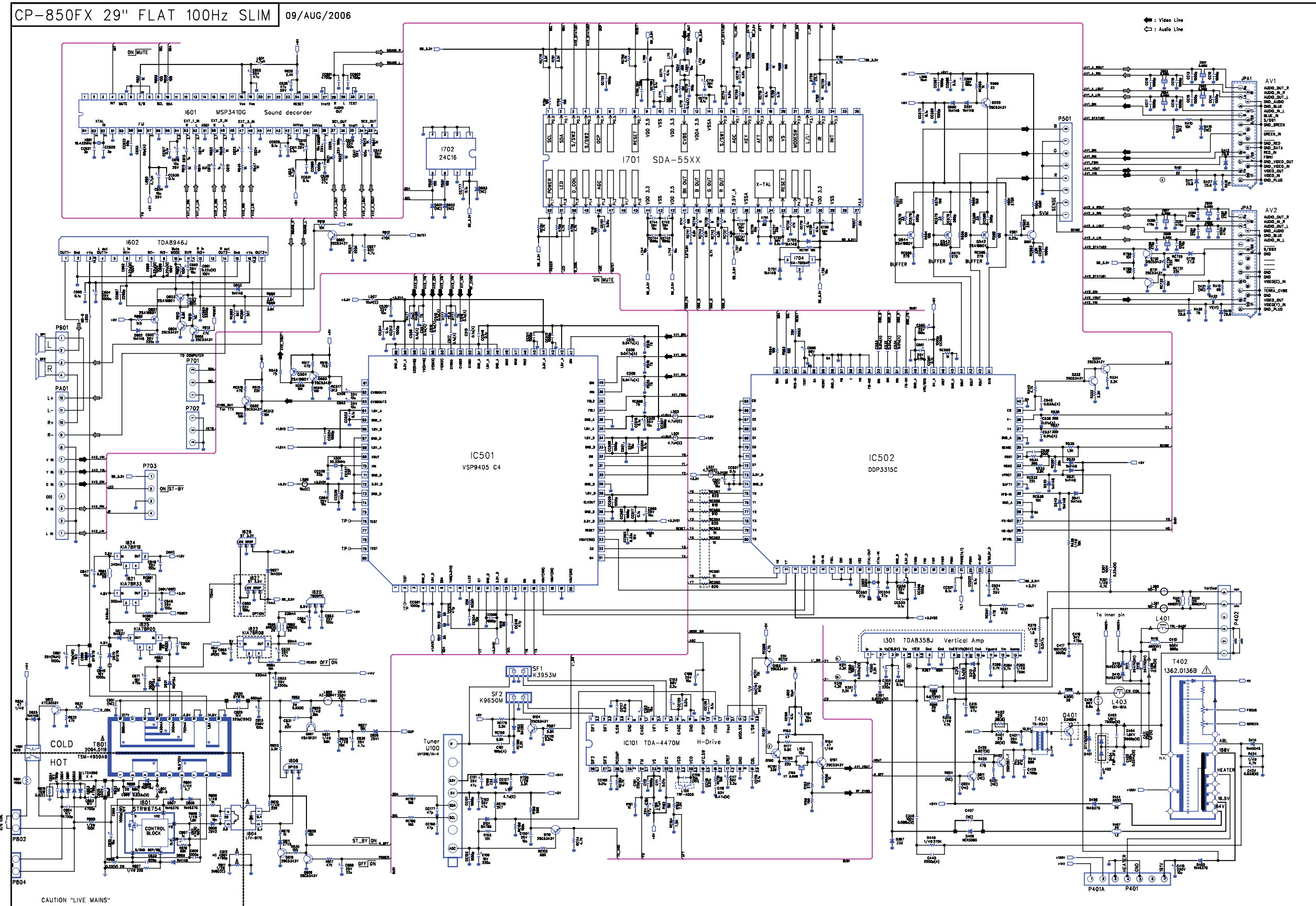

9.2 UNION & CRT

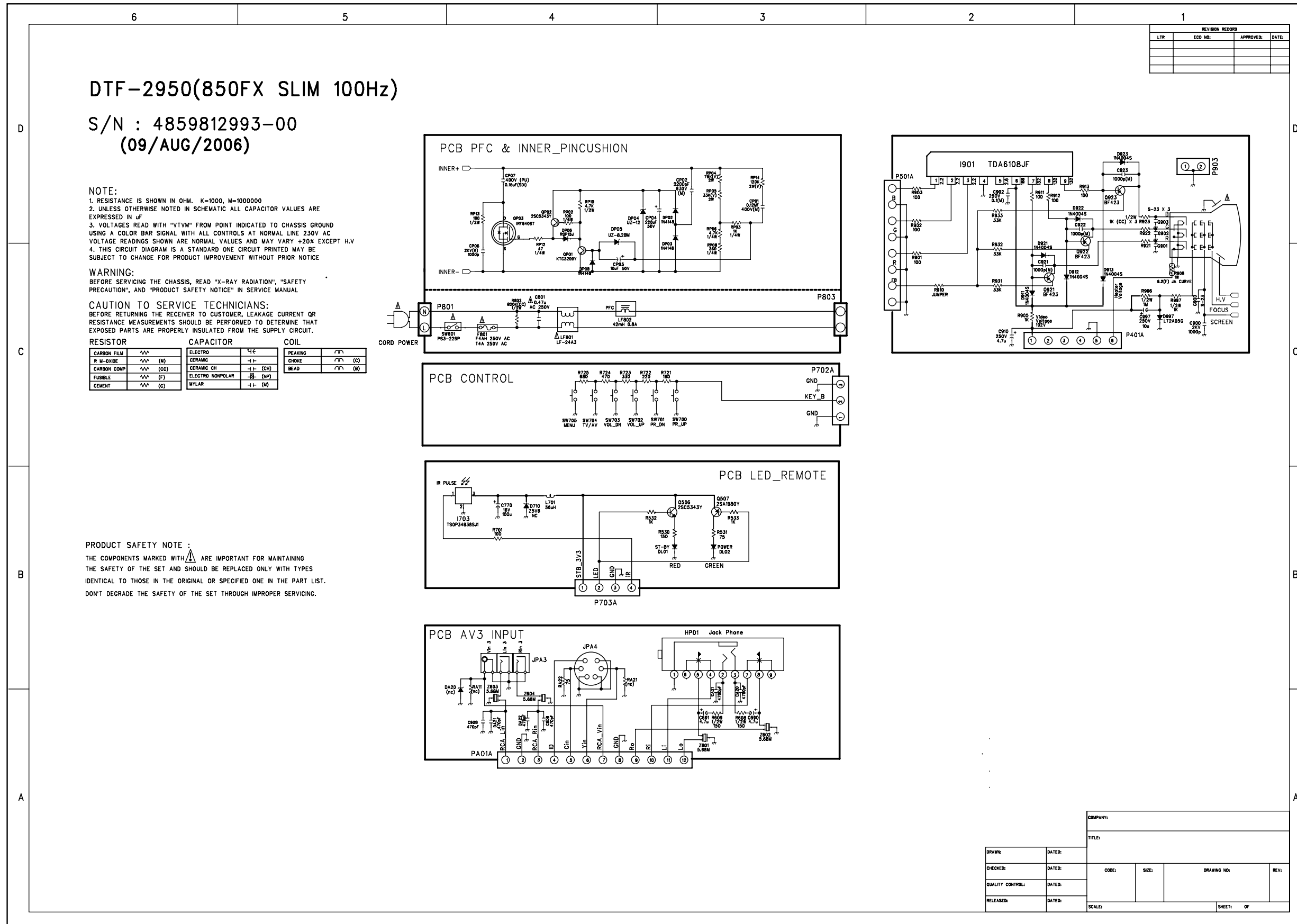



DAEWOO ELECTRONICS CORP.

686, AHYEON-DONG, MAPO-GU,
SEOUL, KOREA.

C.P.O. BOX 8003 SEOUL KOREA

PRINTED DATE : SEP. 2006