

COLOUR TV SERVICE MANUAL

CAUTION

BEFORE SERVICING THE CHASSIS, READ THE "SAFETY PRECAUTIONS" IN THIS MANUAL.

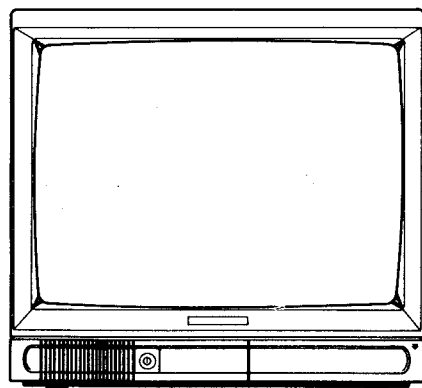

CHASSIS: PC-04A

CONTENTS

Contents and Specifications	2
Safety Precautions	3
Servicing Precautions	4
Controls Location	6
Disassembly Instructions	7
Parts Location Diagram of Main Chassis	8
Adjustment Instructions	9
Circuit Description	14
Troubleshooting Guide	21
Block Diagram	28
Wiring Diagram	29
Terminal View of Semiconductor	30
Component Location Guide	31
Printed Circuit Board	33
Exploded View	35
Replacement Parts List	37
Circuit Diagram	51

SPECIFICATIONS

Power Consumption	80W
Receiving TV System	CCIR Standard
Tuning	40 Voltage Synthesizer
Audio Output	3W
Antenna Input Impedance	75 ohm IEC Type (300-ohm using balun supplied)
Picture Tube	A48KCS12XX 25N7KE
Dimension	492(W) x 462(D) x 458(H)
Weight	18.4 Kg

COLOUR RECEIVING SYSTEM		PAL/SECAM-B/G	PAL B/G- SECAM D/K	PAL-I	PAL-H
Intermediate Frequency	Picture	38.9 MHz	38.9 MHz	39.5 MHz	38.9 MHz
	Sound	33.4 MHz	33.4 MHz	33.5 MHz	33.4 MHz
	Colour	34.47 MHz	34.47 MHz	35.07 MHz	34.47 MHz
Receiving Channel	VHF Low	2-4 CH, S ₁	1-5 CH	NONE	0-5 CH
	VHF High	5-12 CH, S ₂ -S ₂₅	6-12 CH	NONE	5A-11 CH
	UHF	21-69 CH	21-69 CH	21-69 CH	21-69 CH
Power Source		220V/50Hz (SMPS)		240V/50Hz (SMPS)	

SAFETY PRECAUTIONS

WARNING: BEFORE SERVICING THIS CHASSIS, READ THE "X-RAY RADIATION PRECAUTIONS", "SAFETY INSTRUCTIONS" AND "PRODUCT SAFETY NOTICE" DESCRIBED BELOW.

X-RAY RADIATION PRECAUTIONS

1. Excessive high voltage can produce potentially hazardous X-RAY RADIATION. To avoid such hazards, the high voltage must not be above the specified limit. The nominal value of the high voltage of this receiver is 24 ± 1.5 kV at High beam current (maximum brightness) under specified power source. The high voltage must not, under any circumstances, exceed 27.5 KV. Each time a receiver requires servicing, the high voltage should be checked. It is recommended the reading of the high voltage be recorded as a part of the service record. It is important to use an accurate and reliable high voltage meter.
2. The only source of X-RAY RADIATION in this TV receiver is the picture tube. For continued X-RAY RADIATION protection, the replacement tube must be exactly the same type tube as specified in the parts list.
3. Some parts in this receiver have special safety-related characteristics for X-RAY RADIATION protection. For continued safety, parts replacement should be undertaken only after referring to the PRODUCT SAFETY NOTICE below.

SAFETY INSTRUCTIONS

1. Potential as high as 25,000—27,000 volts is present when this receiver is operating. Operation of the receiver outside the cabinet or with the back cover removed involves a shock hazard from the receiver.
 - (1) Servicing should not be attempted by anyone who don't know the precautions necessary through and through when working on high-voltage equipment.
 - (2) Always discharge the picture tube anode to the CHASSIS GROUND to reduce the shock hazard before removing the anode cap.
 - (3) Perfectly discharge the high potential of the picture tube before handling.
(WARNING: Risk of implosion. Handle with care.)
2. If any Fuse in this TV receiver is blown, replace it with the FUSE specified in the chassis parts list only.
3. When replacing parts or circuit boards, wind the lead wires around terminals before soldering.
4. When replacing a high wattage resistor (oxide metal film resistor) in circuit board, keep the resistor 10 mm. away from circuit board.
5. Keep wires away from high voltage or high temperature components.
6. Before returning the set to the customer, always perform an AC leakage current check on the exposed metallic parts

of the cabinet, such as antennas, terminals, screwheads, metal overlays, control shafts, etc., to be sure the set is safe to operate without danger of electrical shock. Since this TV has AVC (Automatic Voltage Control) circuit, it may be operated nonadjustably within the voltage-area indicated in the label attached at back cover. (Do not use a line isolation transformer during this check.) Use an AC voltmeter having 1000 ohms per volt or more sensitivity in the following manner.

Connect a 1000 ohm resistor between a known good earth ground, (water pipe, conduit, etc.) and the exposed metallic parts, one at a time. Measure the AC voltage across the combination of 1000 ohm resistor. Reverse the AC plug at the AC outlet and repeat AC voltage measurements for each exposed metallic part. Voltage measured must not exceed 1 volt RMS. This corresponds to 1 mA. AC. Any value exceeding this limit constitutes a potential shock hazard and must be corrected immediately.

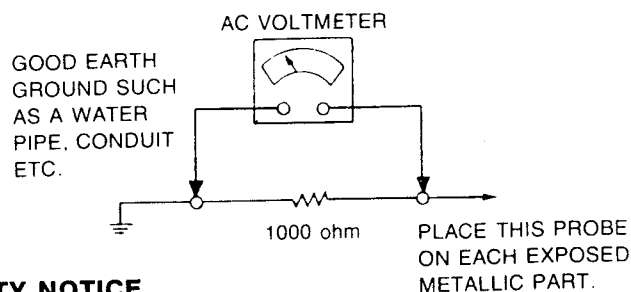

PRODUCT SAFETY NOTICE

Many electrical and mechanical parts in this chassis have special safety-related characteristics. These characteristics are often passed unnoticed by a visual inspection and the X-RAY RADIATION protection afforded by them cannot necessarily be obtained by using replacement components rated for higher voltage, wattage, etc. Replacement parts which have these special safety characteristics are identified by \triangle marks on the schematic diagram and the replacement parts list. Before replacing any of these components, read the parts list in this manual carefully. The use of substitute replacement parts which do not have the same safety characteristics as specified in the parts list may create X-RAY RADIATION.

SERVICING PRECAUTIONS

CAUTION: Before servicing receivers covered by this service manual and its supplements and addenda, read and follow the **SAFETY PRECAUTIONS** on page 3 of this publication. **NOTE:** If unforeseen circumstances create conflict between the following servicing precautions and any of the safety precautions on page 3 of this publication, always follow the safety precautions. *Remember: Safety First.*

General Servicing Precautions

1. Always unplug the receiver AC power cord from the AC power source before;
 - a. Removing or reinstalling any component, circuit board module or any other receiver assembly.
 - b. Disconnecting or reconnecting any receiver electrical plug or other electrical connection.
 - c. Connecting a test substitute in parallel with an electrolytic capacitor in the receiver.
CAUTION: A wrong part substitution or incorrect polarity installation of electrolytic capacitors may result in an explosion hazard.
 - d. Discharging the picture tube anode.
2. Test high voltage only by measuring it with an appropriate high voltage meter or other voltage measuring device (DVM, FETVOM, etc.) equipped with a suitable high voltage probe. Do not test high voltage by "drawing an arc".
3. Discharge the picture tube anode only by (a) first connecting one end of an insulated clip lead to the degaussing or kine aquadag grounding system shield at the point where the picture tube socket ground lead is connected, and then (b) touch the other end of the insulated clip lead to the picture tube anode button, using an insulating handle to avoid personal contact with high voltage.
4. Do *not* spray chemicals on or near this receiver or any of its assemblies.
5. Unless specified otherwise in this service manual, clean electrical contacts only by applying the following mixture to the contacts with a pipe cleaner, cotton-tipped stick or comparable nonabrasive applicator: 10% (by volume) Acetone and 90% (by volume) isopropyl alcohol (90%-99% strength)
CAUTION: This is a flammable mixture. Unless specified otherwise in this service manual, lubrication of contacts is not required.
6. Do *not* defeat any plug/socket B+ voltage interlocks with which receivers covered by this service manual might be equipped.
7. Do *not* apply AC power to this instrument and/or any of its electrical assemblies unless *all* solid-state device heat sinks are correctly installed.
8. Always connect the test receiver ground lead to the receiver chassis ground *before* connecting the test receiver positive lead.
Always remove the test receiver ground lead *last*.
9. Use with this receiver only the test fixtures specified in this service manual.
CAUTION: Do *not* connect the test fixture ground strap to any heatsink in this receiver.

Electrostatically Sensitive (ES) Devices

Some semiconductor (solid state) devices can be damaged easily by static electricity. Such components commonly are called *Electrostatically Sensitive (ES) Devices*. Examples of

typical ES devices are integrated circuits and some field-effect transistors and semiconductor "chip" components. The following techniques should be used to help reduce the incidence of component damage caused by static electricity.

1. Immediately before handling any semiconductor component or semiconductor-equipped assembly, drain off any electrostatic charge on your body by touching a known earth ground. Alternatively, obtain and wear a commercially available discharging wrist strap device, which should be removed to prevent potential shock reasons prior to applying power to the unit under test.
2. After removing an electrical assembly equipped with ES devices, place the assembly on a conductive surface such as aluminum foil, to prevent electrostatic charge buildup or exposure of the assembly.
3. Use only a *grounded-tip* soldering iron to solder or unsolder ES devices.
4. Use only an *anti-static* type solder removal device. Some solder removal devices not classified as "anti-static" can generate electrical charges sufficient to damage ES devices.
5. Do *not* use freon-propelled chemicals. These can generate electrical charges sufficient to damage ES devices.
6. Do *not* remove a replacement ES device from its protective package until immediately before you are ready to install it. (Most replacement ES devices are packaged with leads electrically shorted together by conductive foam, aluminum foil or comparable conductive material.)
7. Immediately before removing the protective material from the leads of a replacement ES device, touch the protective material to the chassis or circuit assembly into which the device will be installed.
CAUTION: Be sure no power is applied to the chassis or circuit, and observe all other safety precautions.
8. Minimize bodily motions when handling unpackaged replacement ES devices. (Otherwise harmless motion such as the brushing together of your clothes fabric or the lifting of your foot from a carpeted floor can generate static electricity sufficient to damage an ES device.)

General Soldering Guidelines

1. Use a grounded-tip, low-wattage soldering iron and appropriate tip size and shape that will maintain tip temperature within the range of 500°F to 600°F.
2. Use an appropriate gauge of RMA resin-core solder composed of 60 parts tin/40 parts lead.
3. Keep the soldering iron tip clean and well tinned.
4. Thoroughly clean the surfaces to be soldered. Use a small wire-bristle (0.5 inch, or 1.25cm) brush with a meal handle. Do not use freon-propelled spray-on cleaners.
5. Use the following unsoldering technique
 - a. Allow the soldering iron tip to reach normal temperature (500°F to 600°F)
 - b. Heat the component lead until the solder melts.
 - c. Quickly draw the melted solder with an anti-static, suction-type solder removal device or with solder braid.**CAUTION:** Work quickly to avoid overheating the circuit board printed foil.
6. Use the following soldering technique.
 - a. Allow the soldering iron tip to reach a normal temperature (500°F to 600°F).
 - b. First, hold the soldering iron tip and solder the strand against the component lead until the solder melts.

- c. Quickly move the soldering iron tip to the junction of the component lead and the printed circuit foil, and hold it there only until the solder flows onto and around both the component lead and the foil.

CAUTION: Work quickly to avoid overheating the circuit board printed foil.

- d. Closely inspect the solder area and remove any excess or splashed solder with a small wire-bristle brush.

IC Removal/Replacement

Some chassis circuit boards have slotted holes (oblong) through which the IC leads are inserted and then bent flat against the circuit foil. When holes are the slotted type, the following technique should be used to remove and replace the IC. When working with boards using the familiar round hole, use the standard technique as outlined in paragraphs 5 and 6 above.

Removal

1. Desolder and straighten each IC lead in one operation by gently prying up on the lead with the soldering iron tip as the solder melts.
2. Draw away the melted solder with an anti-static suction-type solder removal device (or with solder braid) before removing the IC.

Replacement

1. Carefully insert the replacement IC in the circuit board.
2. Carefully bend each IC lead against the circuit foil pad and solder it.
3. Clean the soldered areas with a small wire-bristle brush. (It is not necessary to reapply acrylic coating to the areas).

"Small-Signal" Discrete Transistor Removal/Replacement

1. Remove the defective transistor by clipping its leads as close as possible to the component body.
2. Bend into "U" shape the end of each of three leads remaining on the circuit board.
3. Bend into a "U" shape the replacement transistor leads.
4. Connect the replacement transistor leads to the corresponding leads extending from the circuit board and crimp the "U" with long nose pliers to insure metal to metal contact then solder each connection.

Power Output Transistor Device Removal/Replacement

1. Heat and remove all solder from around the transistor leads.
2. Remove the heatsink mounting screw (if so equipped).
3. Carefully remove the transistor from the heat sink of the circuit board.
4. Insert new transistor in the circuit board.
5. Solder each transistor lead, and clip off excess lead.
6. Replace heatsink.

Diode Removal/Replacement

1. Remove defective diode by clipping its leads as close as possible to diode body.
2. Bend the two remaining leads perpendicularly to the circuit board.
3. Observing diode polarity, wrap each lead of the new diode around the corresponding lead on the circuit board.
4. Securely crimp each connection and solder it.
5. Inspect (on the circuit board copper side) the solder joints of the two "original" leads. If they are not shiny, reheat them and if necessary, apply additional solder.

Fuse and Conventional Resistor Removal/Replacement

1. Clip each fuse or resistor lead at top of the circuit board hollow stake.
2. Securely crimp the leads of replacement component around notch at stake top.
3. Solder the connections.

CAUTION: Maintain original spacing between the replaced component and adjacent components and the circuit board, to prevent excessive component temperatures.

Circuit Board Foil Repair

Excessive heat applied to the copper foil of any printed circuit board will weaken the adhesive that bonds the foil to the circuit board, causing the foil to separate from, or "lift-off" the board. The following guidelines and procedures should be followed whenever this condition is encountered.

At IC Connections

To repair a defective copper pattern at IC connections, use the following procedure to install a jumper wire on the copper pattern side of the circuit board. (Use this technique only on IC connections):

1. Carefully remove the damaged copper pattern with a sharp knife. (Remove only as much copper as absolutely necessary.)
2. Carefully scratch away the solder resist and acrylic coating (if used) from the end of the remaining copper pattern.
3. Bend a small "U" in one end of a small gauge jumper wire and carefully crimp it around the IC pin. Solder the IC connection.
4. Route the jumper wire along the path of the cut-away copper pattern and let it overlap the previously scraped end of the good copper pattern. Solder the overlapped area, and clip off any excess jumper wire.

At Other Connections

Use the following technique to repair the defective copper pattern at connections other than IC Pins. This technique involves the installation of a jumper wire on the component side of the circuit board.

1. Remove the defective copper pattern with a sharp knife. Remove at least 1/4 inch of copper, to ensure that a hazardous condition will not exist if the jumper wire opens.
2. Trace along the copper pattern from both sides of the pattern break and locate the nearest component that is directly connected to the affected copper pattern.
3. Connect insulated 20-gauge jumper wire from the lead of the nearest component on one side of the pattern break to the lead of the nearest component on the other side. Carefully crimp and solder the connections.

CAUTION: Be sure the insulated jumper wire is dressed so that it does not touch components or sharp edges.

IMPORTANT

The wires in this mains lead are coloured in accordance with the following code:

BLUE: NEUTRAL BROWN : LIVE

As the colours of the wires in the mains lead of this apparatus may not correspond with the coloured markings identifying the terminals in your plug proceed as follows: The wire which is coloured blue must be connected to the terminal which is marked with the letter N or coloured black.

The wire which is coloured brown must be connected to the terminal which is marked with the letter L or coloured red.

If a 13 Amp (BS1363) Plug or any other type of Plug is used a 5 Amp Fuse must be fitted, either in the Plug or Adapter, or on the Distribution board.

CONTROLS LOCATION

FRONT

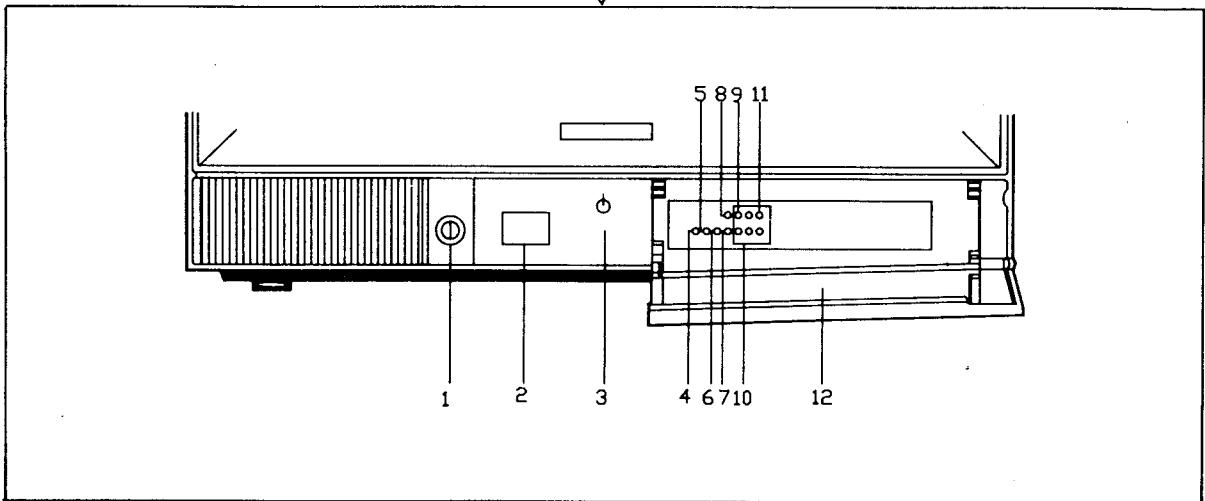
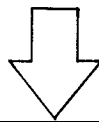
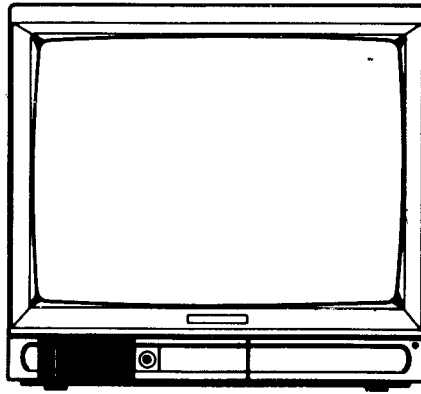

1. MAIN POWER SWITCH	7. PERSONAL PREFERENCE SETTING KEY
2. REMOTE CONTROL SENSOR	8. NORMAL KEY
3. STAND-BY LED	9. VOLUME UP (+)/DOWN (-) KEYS
4. SEARCH KEY	10. MANUAL SEARCH UP (+)/DOWN (-) KEYS
5. CLEAR KEY	11. PROGRAM UP (+)/DOWN (-) KEYS
6. STORE KEY	12. PANEL DOOR

DISASSEMBLY INSTRUCTIONS

BACK CABINET REMOVAL

Remove 6 screws residing on the back cabinet and carefully separate the back cabinet from the front cabinet.

MAIN CHASSIS REMOVAL

Grasp both sides of the main chassis, pull it backward smoothly.

SPEAKER ASSY REMOVAL

1. Remove P602 connector between the speaker and the main chassis.
2. Remove 4 screws holding SPEAKER to the front cabinet.

CPT REMOVAL

1. Pull out the CPT board from the CPT neck.
2. Place the front cabinet on soft material so as not to mar the front surface or damage control knobs.
3. Remove 4 nuts securing the picture tube mounting brackets to the front cabinet.
4. Carefully separate CPT from the front cabinet.

PICTURE TUBE HANDLING CAUTION

Due to high vacuum and large surface area of picture tube, great care must be exercised when handling picture tube. Always lift picture tube by grasping it firmly around faceplate. NEVER LIFT TUBE BY ITS NECK. The picture tube must not be scratched or subjected to excessive pressure as fracture of glass may result in an implosion of considerable violence which can cause personal injury or property damage.

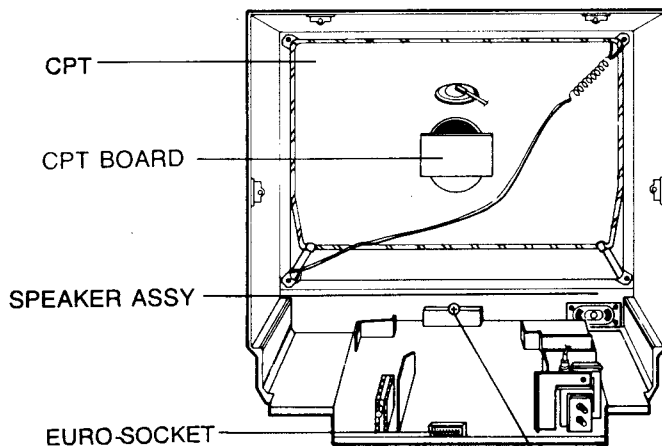
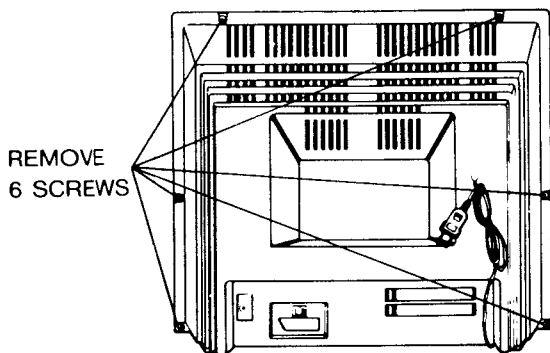

Since this screw is holding the main chassis, remove it from the front cabinet

PARTS LOCATION OF MAIN CHASSIS

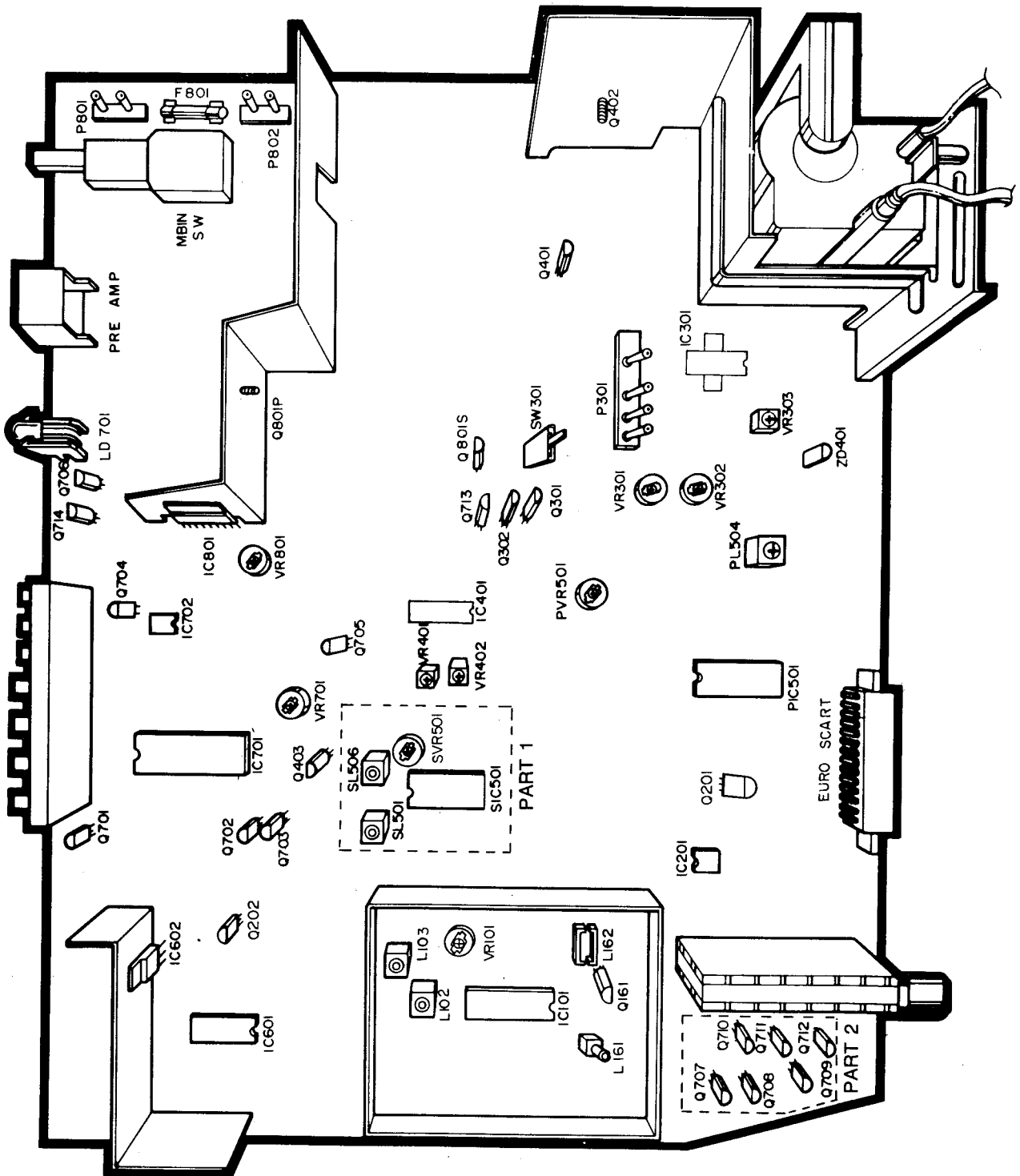

*** NOTICE:**

In case of the model without teletext, get rid of Q301, Q302.
 In case of the model without SECAM system, get rid of PART 1.

In case of the model with PAL-I system, get rid of PART 1, 2 and L161.

PC-04A ALIGNMENT INSTRUCTIONS

1. APPLIANCE

This instruction is applicable for all models using the PC04A CHASSIS.

2. SPECIFICATION

2-1 CIRCUMFERENCE CONDITION

If there is no particular guidance, adjust under the following condition.

- 1) Circumference Temperature: $20^{\circ}\text{C} \pm 5^{\circ}\text{C}$
- 2) Relative Humidity: $65\% \pm 5\%$

2-2 NECESSARY INSTRUMENTS

3. ALIGNMENT

3-1 VIF ALIGNMENT

- 1) Connection Diagram of Equipments

- 1) DC Power Supplier (0-20V, 1A): 2EA
- 2) Sweep Generator and Marker unit of Each System
- 3) Alignment Scope
- 4) DC Voltmeter (High Impedance)
- 5) PAL/SECAM Colour Bar, Signal Generator
- 6) Frequency Counter

2-3 SIGNAL

Standard colour signal which is out from Goldstar standard digital signal Generator (PM5544).

2-4 POWER SOURCE (In Case of Receiver Operation)

AC 180V-270V, 50/60Hz.

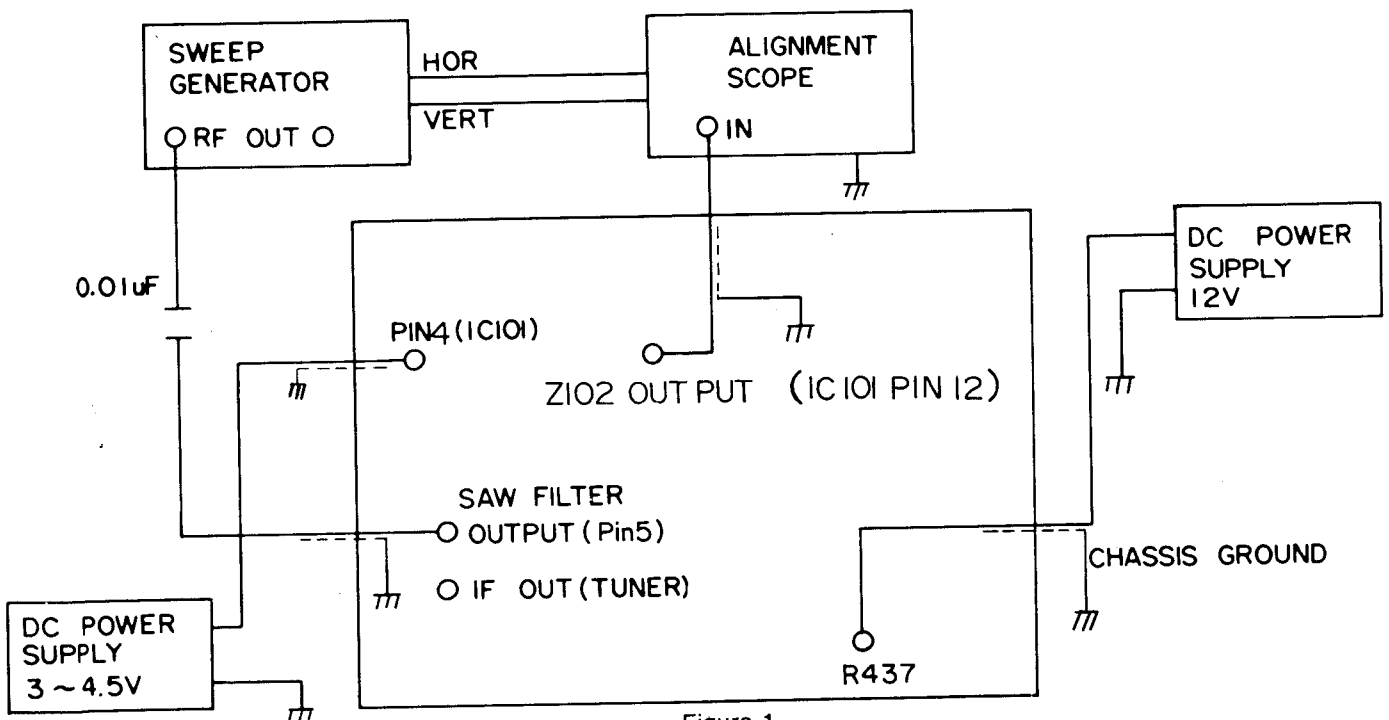

Figure 1

* Connect the ceramic condenser (0.01uF) between RF-OUT terminal of the SWEEP GENERATOR and SAW FILTER OUT terminal.

2) VIF Detection Coil Alignment

- a) Do the connection as shown in figure 1 and then DC power suppliers on.

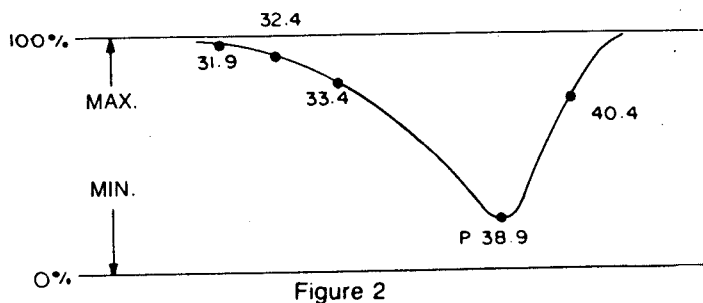

Figure 2

- b) Adjust L103 (Detection Special Quality Adjustment Coil) in order to minimize the PICTURE CARRIER MARK as shown in figure 2.

(For Mark Frequency of Each System, refer to the below note (*)).

* Each frequency carrier of system.

- PAL B/G: 38.9 MHz
- PAL I: 39.5 MHz
- PAL II: 39.5 MHz
- PAL D/K: 38.9 MHz
- PAL/SECAM B/G: 38.9 MHz
- PAL/SECAM B/G, D/K: 38.9 MHz

- 3) ASC (40.4 MHz) Alignment (L161)
 - a) This alignment is only applicable to the model with ASC TRAP for FTZ.
 - b) The connection of alignment is the same as figure 1 but connect RF OUT of the SWEEP GENERATOR to TURNER IF OUTPUT terminal of Main PCB.
 - c) Turn L161 counterclockwise so that CORE may be appeared to maximum and then adjust it clockwise.
 - d) After setting output of SWEEP GENERATOR to maximum, increase IF AGC voltage of pin 4 (IC101) about 5V so that waveform may be distinguished the variation of L161 in the saturated state.
 - e) Adjust L161 so that 40.4MHz POINT may be maximum.

3-2 AFT ALIGNMENT (L102)

NOTE) Cut the SLIT part of the C106(+) before adjusting.

- 1) The connecting of equipments is the same procedure as that above b) item. but the connection position of Alignment Scope must be changed from output terminal of Z102 to pin 12 of IC101.
- 2) Set VERTICAL GAIN of SCOPE to 1Vp-p/dIV and set the SWEEP GENERATOR output to a low state possibly.
- 3) Adjust L102 so that it may be the same as shown in figure 3.

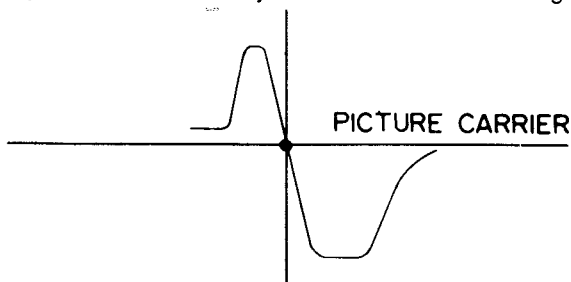

Figure 3 (AFT Alignment Waveform)

- 4) After finishing the adjustment, connect SLIT of the C106(+).

3-3 MAIN B+ (112V or 118V DC) ALIGNMENT

- 1) Turn on the TV set.
- 2) Receive the standard colour signal. (digital pattern)
- 3) Set the portion of colour, Bright, Contrast to the maximum.
- 4) Adjust VR801 so that the voltage of J122(TP6) may be 112V for the model smaller than 21" and 118V for 21" model.

3-4 HORIZONTAL SYNCHRONIZATION ALIGNMENT

- 1) Receive the standard color signal on the TUNER ANTENNA.
- 2) Connect SYNC. SEPARATOR INPUT SIGNAL to the Ground.
(Connect pin 11 of IC401 to the GND... J110, J111, TP3 part)
- 3) Adjust VR401 so that the screen may be maintained the synchronization in a horizontal and vertical direction.
- 4) Remove the connection of pin 11 of IC401 from GROUND.

3-5 HORIZONTAL CENTER ALIGNMENT (HOR.SHIFT ALIGNMENT)

- 1) Receive the standard colour signal.
- 2) Adjust the VR402 so that the screen may be the Geometric center.

3-6 VERTICAL OSCILLATOR FREQUENCY ALIGNMENT

- 1) Adjust the set in no signal condition.
- 2) Connect the frequency COUNTER to the CONNECTOR part (R304) which is connected with vertical DY.

(Connect the (-) side of the connector to the heat sink of the chassis)

- 3) Adjust VR302 so that FREE-RUN frequency may be $46.00 \pm 0.5\text{Hz}$.

3-7 VERTICAL AMPLITUDE AND LINEARITY ALIGNMENT (VERT. HEIGHT AND LINEARITY ALIGNMENT)

- 1) When brightness of a screen is minimum as receiving the FuBK TEST PATTERN, adjust VR301 so that the outline signal of the upper and lower parts of the great circle on screen may be coincide with the edge of a effective screen.
- 2) After changing the signal to Digital, adjust VR303 so that the length of upper and lower of the great circle may be equal.

3-8 VERTICAL CENTER ALIGNMENT

Adjust SW301 (Vertical Center SVC.S/W) so that CENTER of PATTERN may coincide with the Geometric center of an effective CPT screen.

3-9 COLOUR SYNCHRONIZATION ALIGNMENT

- 1) Receive the standard colour signal.
- 2) Set the Contrast, Brightness, Colour VR to maximum.
- 3) Connect the COLOUR SATURATION terminal to 12V.
- 4) Short the INPUT pin 21 (B-Y), PIN 22 (R-Y) of the IC501.
- 5) Adjust the PTC501 (TRIMMER CAPACITOR) so that COLOUR BAR should not flow down.
- 6) After finishing adjustment, remove the connection of item 3) and 4).

3-10 PAL MATRIX ALIGNMENT

- 1) Set the Contrast, Brightness, Colour Control VR to the maximum.
- 2) Receive the DEM. PATTERN (Colourless Pattern).
- 3) Connect the SCOPE to the B-OUT (Pin 16 of PIC501).
- 4) Adjust PVR501 to obtain a minimum fluctuation (A straight line) in figure 4-1.

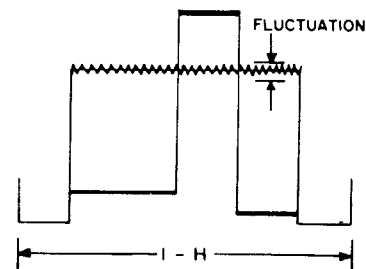

Figure 4-1. PVR501 Alignment

- 5) After changing the PATTERN into the PAL COLOUR BAR signal, adjust PL504 so that the fluctuation may be minimum and a straight line as shown in figure 4-2.

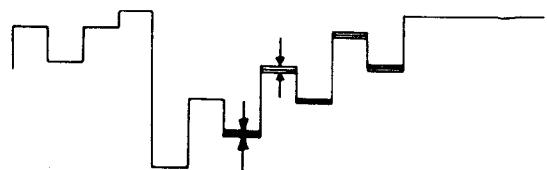

Figure 4-2. PL504 Alignment

- 6) Repeat the adjustment of the above items 4), 5) again by varying the pattern and then confirm.

3-11 RF AGC ALIGNMENT

- 1) Receive the standard colour signal (60dB \pm 1dB), but in base of PAL-I, receive 70dB \pm 1dB.
- 2) Connect DIGITAL MULTIMETER to AGC terminal of the TUNER (J20, TP1).
- 3) Refer to below diagram and then adjust VR101.

Tuner System	B/G	I	B+H	D/K
ALPS	4.8 \pm 0.1dc	4.9 \pm 0.1dc	4.8 \pm 0.1dc	4.8 \pm 0.1dc

* Select the best point in accordance with the TUNER, SYSTEM or per production LOT.

3-12 SCREEN AND WHITE BALANCE ALIGNMENT

- 1) Set the Colour, Brightness, Contrast alignment VR to the minimum.
- 2) Set the BIAS ALIGNMENT VR(VR901-903) and DRIVE ALIGNMENT VR(VR904-905) of CPT BOARD to the mechanical center position.
- 3) Tune in channel No. 05CH.
- 4) Vary SCREEN VR of FBT until the screen will be cut off.
- 5) As using Color Analyze White Balance checker, adjust it to be X equal to 281 \pm 8 and Y equal to 288 \pm 8 in the Low light(4-5ft.L) and High Light(40-50ft.L).

3-13 FOCUS ALIGNMENT

- 1) Receive the standard Digital signal and adjust the Contrast, Brightness, Colour to be maximum.
- 2) Adjust it so that HALO situation should not appear on the portions as follows. (Center, edges and logo portion)

4. SECAM ALIGNMENT

4-1 SECAM BELL FILTER ALIGNMENT

- 1) Receive the SECAM BAR PATTERN.
- 2) Connect the LOW CAPACITANCE PROBE to pin 4 of SIC501. (Using FET PROBE)
- 3) Adjust SL501 to maximize and flatten the waveform.
- 4) In case of not using FET PROBE, precede the above adjustments (1 to 3).

And then adjust the GS standard SECAM SIGNAL so that the COLOUR of 3.8MHz portion may be red and minimize the MAGENTA COLOUR of the COLOUR BAR and the shadows of the BLACK LEVEL BAR boundary.

- 5) In accordance with necessary, adjust the DIGITAL PATTERN signal with the maked scale.

4-2 SECAM REFERENCE COIL ALIGNMENT

- 1) Connect OSCILLOSCOPE PROBE to pin 24 of SIC501.
- 2) Ground pin 11 and pin 16 of SIC501. (Only SECAM MODE)
- 3) Turn out SVR501 clockwise to the maximum.
- 4) Adjust SL506 so that the DC LEVEL of the parts A,B (figure 6) may coincide.

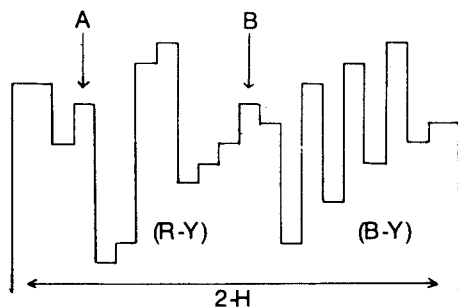

Figure 6. Pin 24 Waveform

- 5) Move the OSCILLOSCOPE PROBE to pin 10 of the SIC 501.
- 6) Adjust SVR501 so that the right and left LEVEL of R-Y and B-Y part may be equal and the waveform of part A may be coincide to be one.

To be equaled the whole size

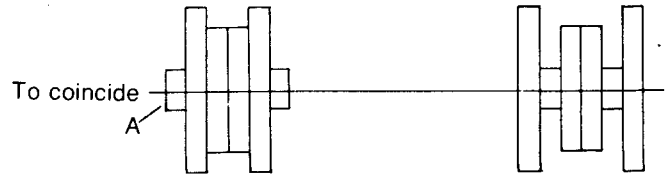

Figure 6. Pin 10 Waveform

- 7) If the field color differs from that of the pal signal, leaving SL506, adjust SVR501 in full detail.

5. OSD POSITION ALIGNMENT

- 1) Turn on the set and adjust it to be non-signal condition.
- 2) Push the SEARCH KEY.
- 3) Adjust VR701 so that the size of Analogue TUNING BAR may be coincide with the right and left side of the screen.

6. TELETEXT(F6) ALIGNMENT

This alignment is applied only to the TV that contains the TXT receiver (111-D67A).

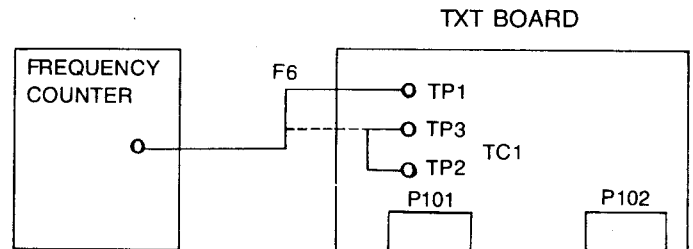

Figure 7. Connection Diagram of the Instruments

2) PREPARATION OF ALIGNMENT

- a) Connect with the Instrument shown as in figure 7. (TP2, TP3 are GND).
- b) Receive the TV signal including the TXT signal on the TV Antenna. (Input=RF signal LEVEL must be 80 \pm 10dBuV.)
- c) Change the TV to the TXT MODE.

3) ALIGNMENT

Adjust TCI so that TP1(F6) Frequency being shown with the Frequency Counter may be between 6,000,050 Hz and 6,000,150 Hz.

PURITY AND CONVERGENCE ADJUSTMENT

CAUTION: Convergence and Purity have been factory aligned. Do not attempt to tamper with these alignments. However, the effects of adjacent receiver components, or replacement of picture tube or deflection yoke may require the need to readjust purity and convergence. Convergence magnet assembly and rubber wedges need mechanical positioning following the figure 8. Before attempting any convergence adjustments this receiver should be operated for at least fifteen minutes. If adjustments are required the adjustments should be made in the following sequence.

COLOUR PURITY ADJUSTMENT

1. Demagnetize the picture tube and cabinet using a degaussing coil.
2. Turn the CONTRAST and BRIGHTNESS controls to maximum.
3. Select the purity pattern consisted of green only on the pattern generator.
4. Loosen the clamp screw holding the yoke, and slide the yoke backward to provide vertical green belt (zone) in the picture screen.
5. Remove the Rubber Wedges.
6. Rotate and spread the tabs of the purity magnet (See figure 9) around the neck of the picture tube until the green belt is in the center of the screen. At the same time, center the raster vertically.
7. Move the yoke slowly forward or backward until a uniform green screen is obtained. Tighten the clamp screw of the yoke temporarily.
8. Check purity of the red and blue rasters by selecting the purity pattern of pattern generator.
9. Obtain a white raster, referring to 'WHITE BALANCE ADJUSTMENT'.
10. Proceed with convergence adjustment.

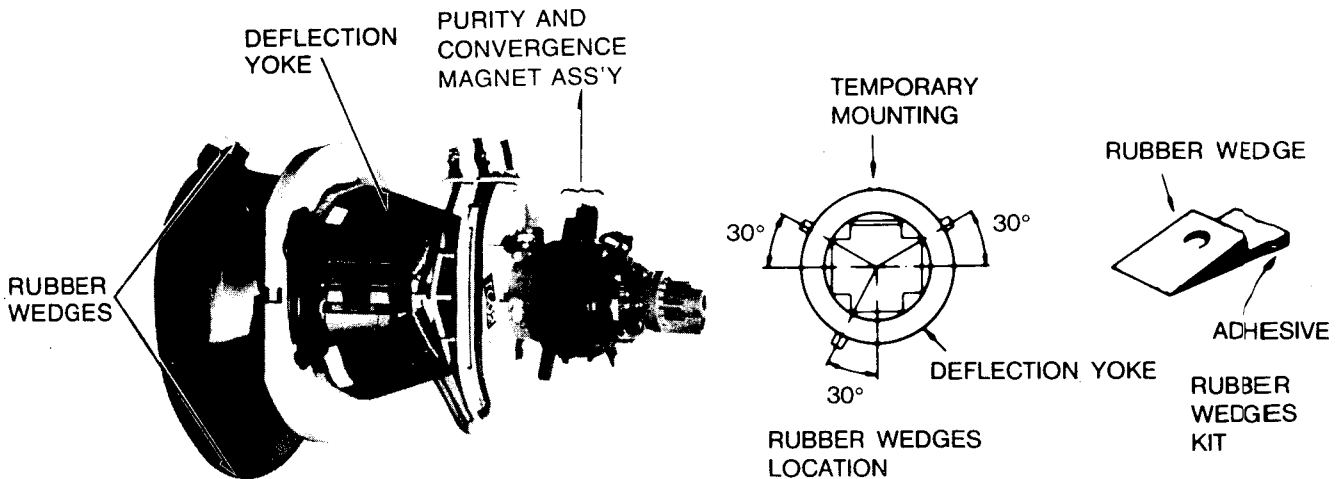

Figure 8

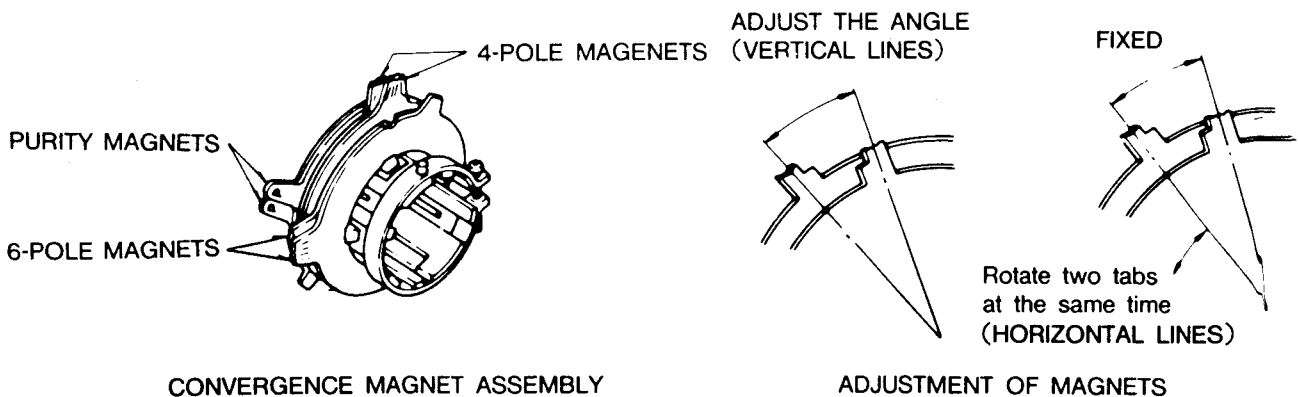

Figure 9

CENTER CONVERGENCE ADJUSTMENT

1. Receive crosshatch pattern with a colour bar signal generator.
2. Adjust the BRIGHTNESS and CONTRAST controls for well defined pattern.
3. Adjust two tabs of the 4-pole magnets to change the angle between them (See figure 9) and superimpose the red and blue vertical lines in the center area of the picture screen. (See figure 9.)
4. Turn both tabs at the same time keeping their angles constant to superimpose red and blue horizontal lines at the center of the screen. (See figure 10)
5. Adjust two tabs of 6-pole magnets to superimpose red/blue line with green one. Adjusting the angle affects the vertical

- lines and rotating both magnets affects the horizontal lines.
6. Repeat adjustments 1,2,3, keeping in mind red, green and blue movements, because 4-Pole magnets and 6-Pole magnets interact and make dot movement complex.

CIRCUMFERENCE CONVERGENCE ADJUSTMENT

1. Loosen the clamping screw of DY to allow the yoke to tilt.
2. Adjust DY to obtain a better convergence in the circumference by orbital movement of the front of the yoke, then secure the DY in appropriate position by placing the wedges as illustrates in figure 8. Tighten screw holding the DY. Stick 3 adhesive tapes on wedges as shown in figure 8.

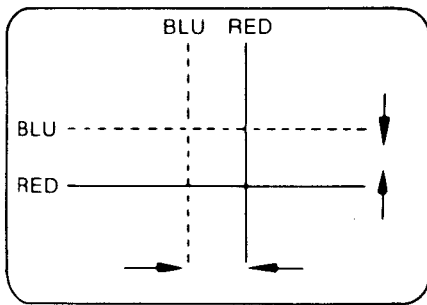

4-Pole Magnets Movement

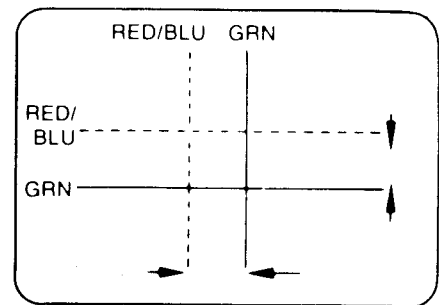

6-Pole Magnets Movement

Center Convergence by Convergence Magnets

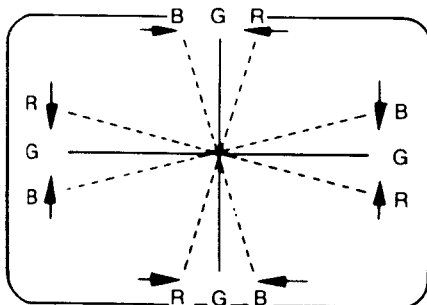

Incline the Yoke up (or down)

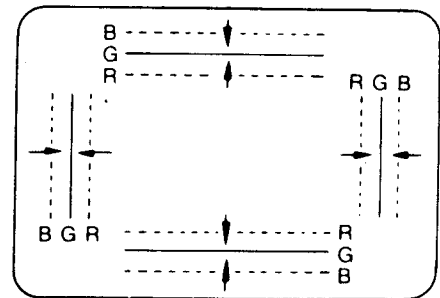

Incline the Yoke right(or left)

Circumference convergence by Deflection Yoke

Figure 10 DOT MOVEMENT PATTERN

CIRCUIT DESCRIPTION

1. VIDEO IF AMPLIFIER CIRCUIT (IC101, $\mu 4439BG$)

1-1 The Basic Construction

Video IF Amplifier Circuit contains three symmetric of IF AMP (Video IF Dctor & AMP, AFT circuit & AMP and AGC circuit). All of above functions are performed in IC101 ($\mu 4439BG$). The schematic diagram is same as figure 11.

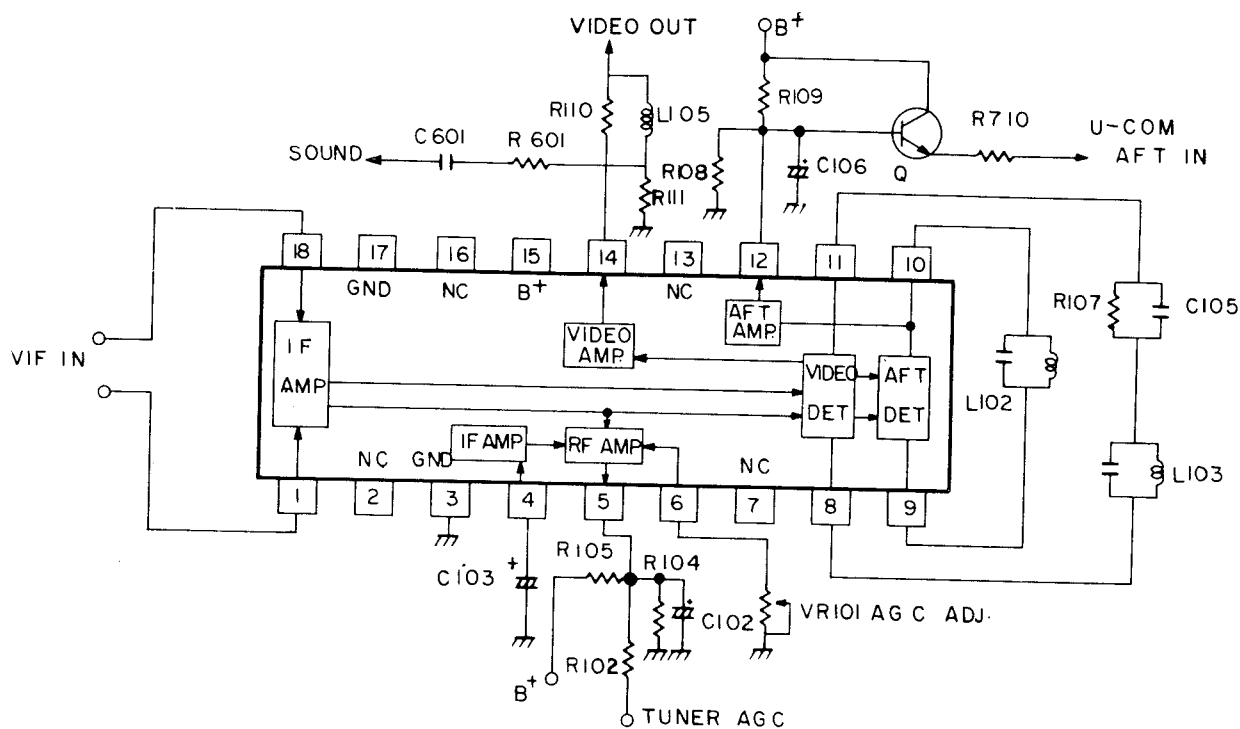

Figure 11. Schematic Diagram of IC101 ($\mu 4439BG$)

1-2 Pin Configuration of IC101

Pin No.	Description
1, 18	IF IN
2, 7, 16	NC
3, 17	Ground
4	IF AGC storage capacitor
5	The output terminal of RF out
6	RF AGC control terminal
8, 11	Video detector
9, 10	AFT detector
12	AFT output
14	Video output • Composite video output level: 3Vp-p • White level: 5.2V • Black clamping level: 1.9 V
15	Supply voltage terminal • voltage: about 12 V _{DC} • current: 75 mA

1-3 Operating Description of the Circuit

After the air signal is varied into the IF signal through the TUNER of the TV set, this signal which is passed via PRE-AMP and SAW FILTER input into pins 1, 18 of IC101 via. This IF signal passes into the three stage AMP. and then video signal is detected by the detector coil connected to pins 8, 11. AFT signal is also detected by the dector coil connected to pins 9, 10. They are output each video signal in pin 14, AFT signal in pin 12 through the AMP. Also, AGC voltage passes pin 5 after adjusting VR101 (AGC adjustment variable rasistor) connected pin 6 and this voltage is connected to the AGC terminal of the TUNER, so that the AGC voltage is controlled.

2. SOUND IF AMPLIFIER CIRCUIT (IC601, TBA120T)

2-1 The Basic Construction

SIF AMP as FM IF AMP & Demodulator is composed of SIF AMP, SIF Detector, sound output, volume control and external audio in/out.

These circuits are operated within IC601.

The schematic diagram is same as figure 12.

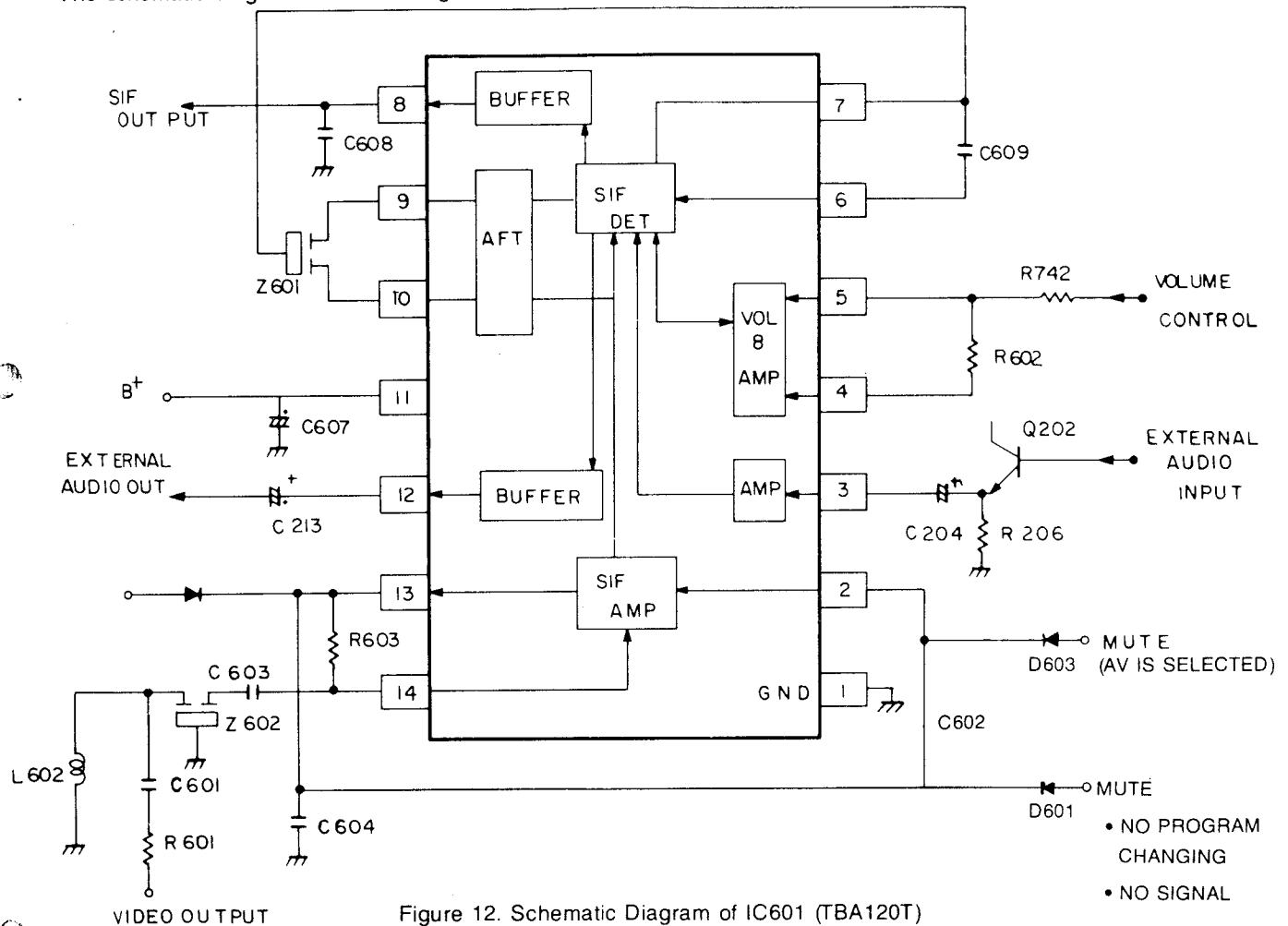

Figure 12. Schematic Diagram of IC601 (TBA120T)

2-2 Pin Configuration of IC601

Pin No.	Description
1	Ground
2, 13	Sound Amp. Negative feed back terminal
3	External audio input terminal
4	Volume control reference terminal Reference voltage: 4.8V
5	Volume control terminal
6, 7	SIF detector.
8	SIF output Output voltage: 4V
9, 10	FM detector
11	Supply voltage terminal; 12V
12	External audio output

2-3 Operating Description of the Circuit

Sound carrier is detected by the composite video signal gone through band pass filter(BPF), (which is composed of R601, C601, L601) and ceramic discriminator (Z602), and it is applied to SIF AMP. (pin13).

The amplified signal is applied to the SIF Detector Terminal.

And, after detection, this signal outputs into pin8 through the Buffer Circuit.

This output signal is controlled, by inputting to pin5 volume level which is controlled by the μ -com (IC701).

The detected Audio Signal outputs into pin12 through the Buffer Circuit and this signal is the Audio output signal. The Audio signal input from the external is input into pin3 and is detected through AMP and is output at pin8 through the Buffer Circuit.

3. HORIZONTAL DEFLECTION CIRCUIT (IC401, TDA1940)

3-1 The Basic Construction

Horizontal Deflection Circuit consists of Sync. Separator Circuit 01 & 02, Phase-Comparator, Super Sandcastle(SSC) Pulse Generator, Horizontal Sync. output circuit, Vertical pulse Generator, burst gating Generator. Schematic Diagram of IC401 is same as figure 13.

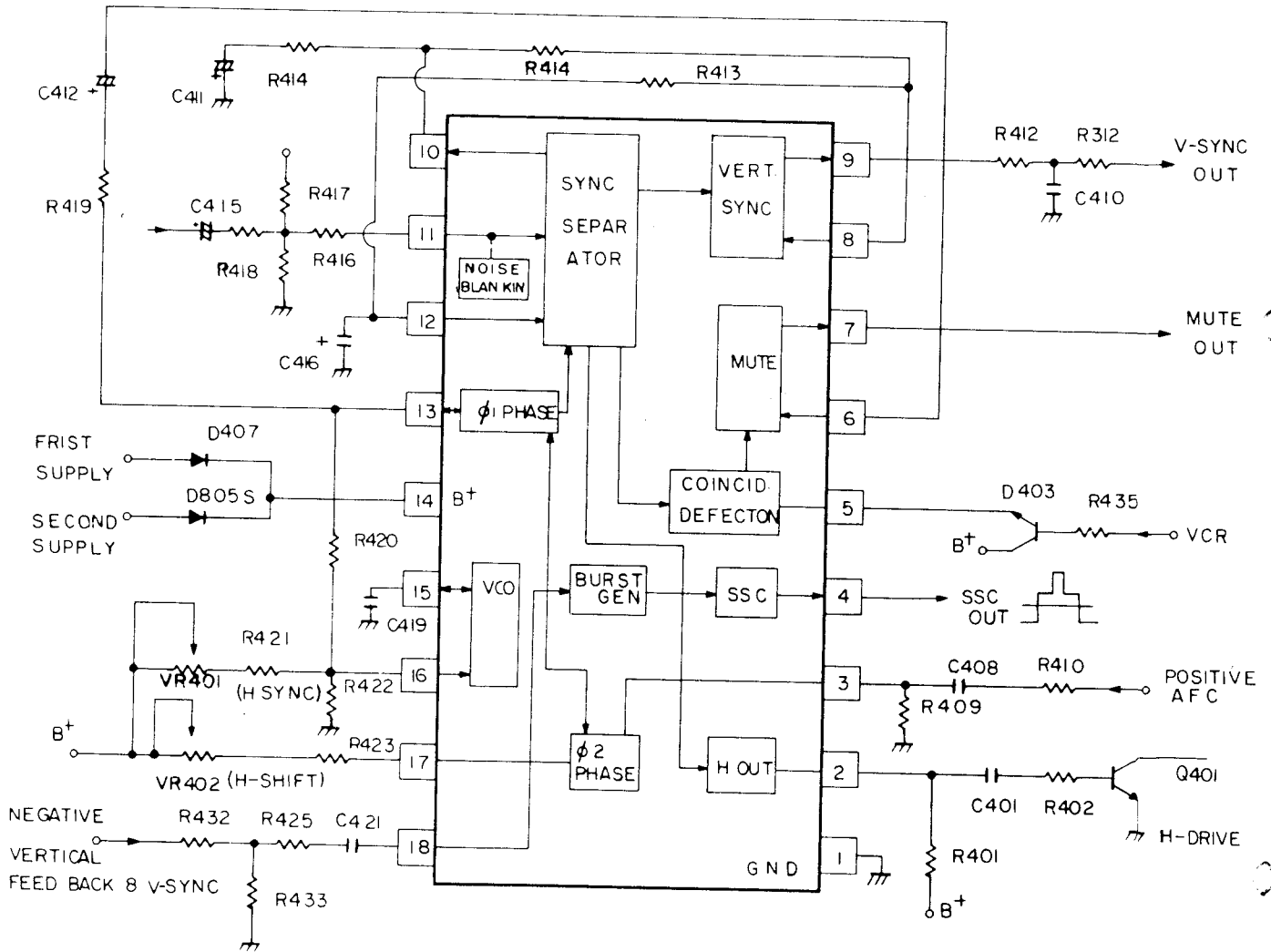

Figure 13. Schematic Diagram of IC401

3-2 Pin Configuration of IC401

Pin No.	Description
1	GND
2	Horizontal Sync output
3	Positive flyback pulse(AFC) input
4	Super sandcastle pulse(ssc) out
5	Output of coincidence detector : In case of the external VCR Mode, used as the auto time constant switching terminal.
6	Input time-constant switching stage
7	If there is the broadcast signal, as the muting circuit output stage, it is high. In case of non-signal condition, keeps the low condition.
8	The reference stage for the vertical sync pulse
9	Vertical sync pulse output
10	Horizontal pulse separator H/V clamping stage
11	Video signal input stage
12	Reference input stage for line pulse separation
13	<ul style="list-style-type: none"> • First phase comparator • Used as H-sync of ON-SCREEN.
14	<ul style="list-style-type: none"> • Supply voltage stage • Supply voltage: 12V • Supply current: 40mA
15	Horizontal oscillator frequency control is selected with the time constant of R422 and C419.
16	<ul style="list-style-type: none"> • Horizontal oscillation frequency control stage. • Controls horizontal sync. with VR401
17	Second phase comparator stage (0, phase DET.)
18	<ul style="list-style-type: none"> • Vertical flyback pulse feedback input stage • Requires the negative vertical pulse. • Used as V-sync. of ON-SCREEN.

3-3 Operating Description of the Circuit

3-3-1. START-UP

If the power switch is ON, the supply voltage (12V) of SMPS transformer is applied to pin14 through D407. At that time IC401 begins to oscillate with the starting voltage, and the horizontal sync. pulse outputs through pin2. And then the horizontal sync. pulse is applied to Q401 (Horizontal Drive Transistor) through C401 and C402 to drive Q401, which cause that the second supply voltage supplied from FBT is applied to pin14 through D805S by loading the horizontal output circuit.

3-3-2. HORIZONTAL OSCILLATION AND PHASE SHIFT

The oscillation signal controlled by R422, C419 and VR401 makes the horizontal synchronizing signal which is divided by pins10, 11 and 12.

And then, by comparing with a part of compared-waveform vertical signal at the first phase and the second phase, the horizontal synchronizing signal makes the final output signal, and the phase shift is made by VR402.

3-3-3. SYNC. SEPARATOR

R417 and R418 connected to pin11 select the input level

which IC401 of the sync. separator circuit demands and the slicing level for the sync. separator. And it is the important factor of selecting the level which checks whether the broadcasting signal is or not.

3-3-4. SUPER SANDCASTLE PULSE

The super sandcastle pulse output from pin4 is composed of three levels, and it is applied to pin8 of PIC501 (PAL chroma IC) and pin23 of SIC501. (SECAM decoder IC).

3-3-5. VCR MODE SECTION

If the high voltage is supplied to pin5 of IC401 from tuning μ -com, the second phase detector is changed to the fast mode, this mode is selected to operate by the VCR or A/V signal which is input from the external.

3-3-6. VERTICAL SECTION

Video signal is received through pin11. The vertical sync. signal is output from 9. By dividing the vertical sync. signal at the vertical sync. signal separator circuit which is connected to pins8, 9.

4. VERTICAL DEFLECTION CIRCUIT (IC301, TDA1170N)

4-1 Basic Construction

The Vertical Deflection Circuit consists of the vertical Sync. Input terminal, Ramp Generator, Vertical Sync. Circuit, Flyback Generator (Vertical output stage) Power Amplifier Circuit, Preamplifier Circuit.

*The Schematic diagram of IC301 is same as figure 14.

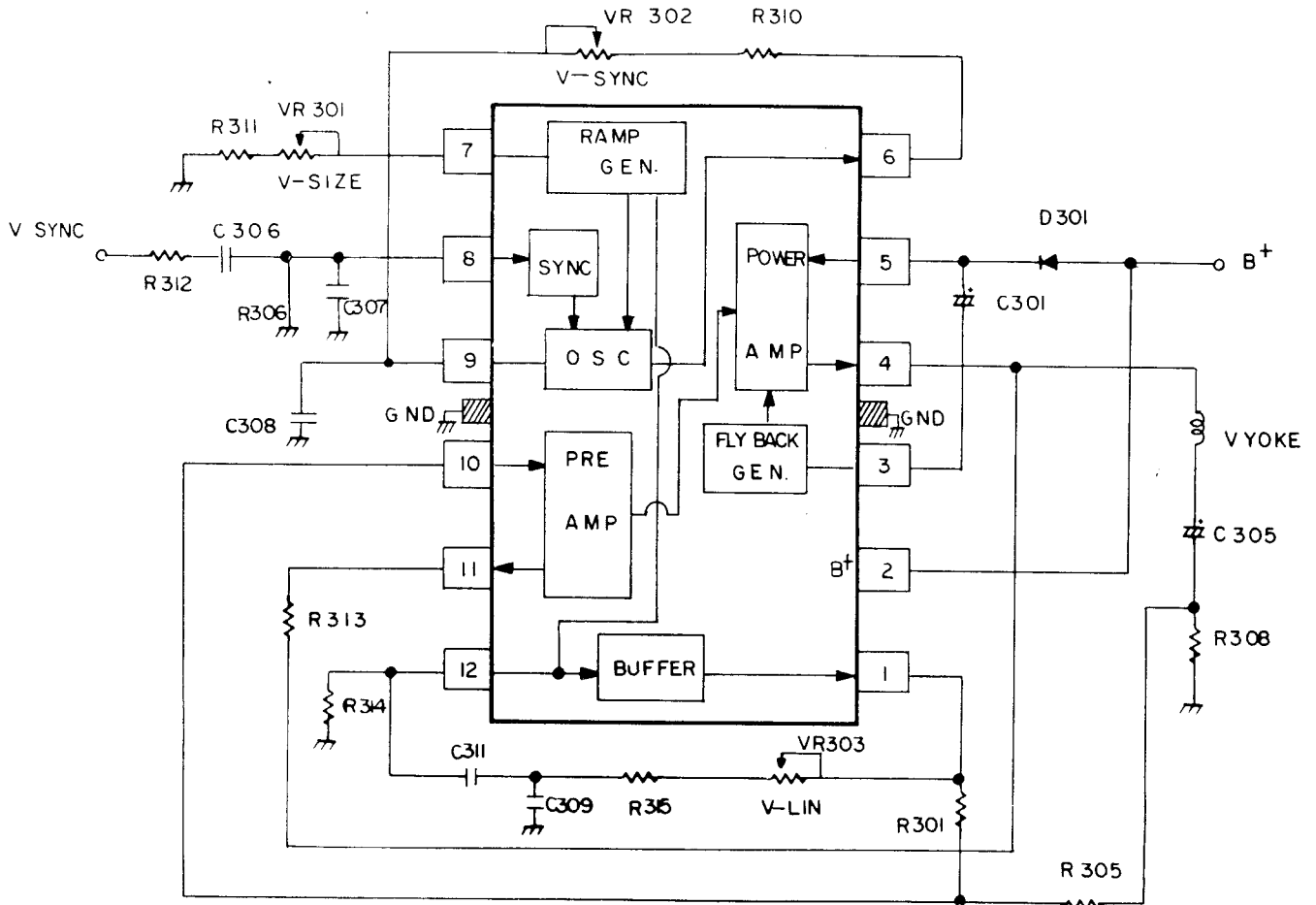

Figure 14. Schematic Diagram of IC301.

4-2 Pin Configuration of IC301

Pin No.	Description
1	Buffer stage
2	Voltage supply stage Supply voltage: 25V Supply current: 140mA
3	Flyback generator
4	Vertical output
5	The supply terminal of the vertical output circuit
6, 9	Vertical sync control stage. (Adjusts the frequency of V-sync. by VR302.)
7	• Ramp generator stage • Adjusts V-size by adjusting VR301.
8	Vertical sync. input & sync. amplifier
10, 11	Preamplifier reference input and vertical feedback
12	Adjusts the vertical linearity by adjusting reference current of the Ramp Generator.

4-3 Operating Description of the Circuit

The vertical sync. signal output through pin 9 of IC401 enters the vertical sync. input circuit and AMP. circuit and makes the saw-form signal by the time constant of C308 connected to pin 9 and R310 connected to pin 6. And then VR302 controls the vertical sync. Also, this signal controls the vertical size by being supplied to the Ramp Generator circuit connected to pin 7. The signal phase generated from the oscillator and the Ramp Generator is compared with the phase of the vertical feedback signal, so that this signal may be obtain through the vertical amplifier, is output-through pin 4 and supplied to the deflection yoke.

5. CHROMA & LUMINANCE CIRCUIT (PIC501, TDA3560A)

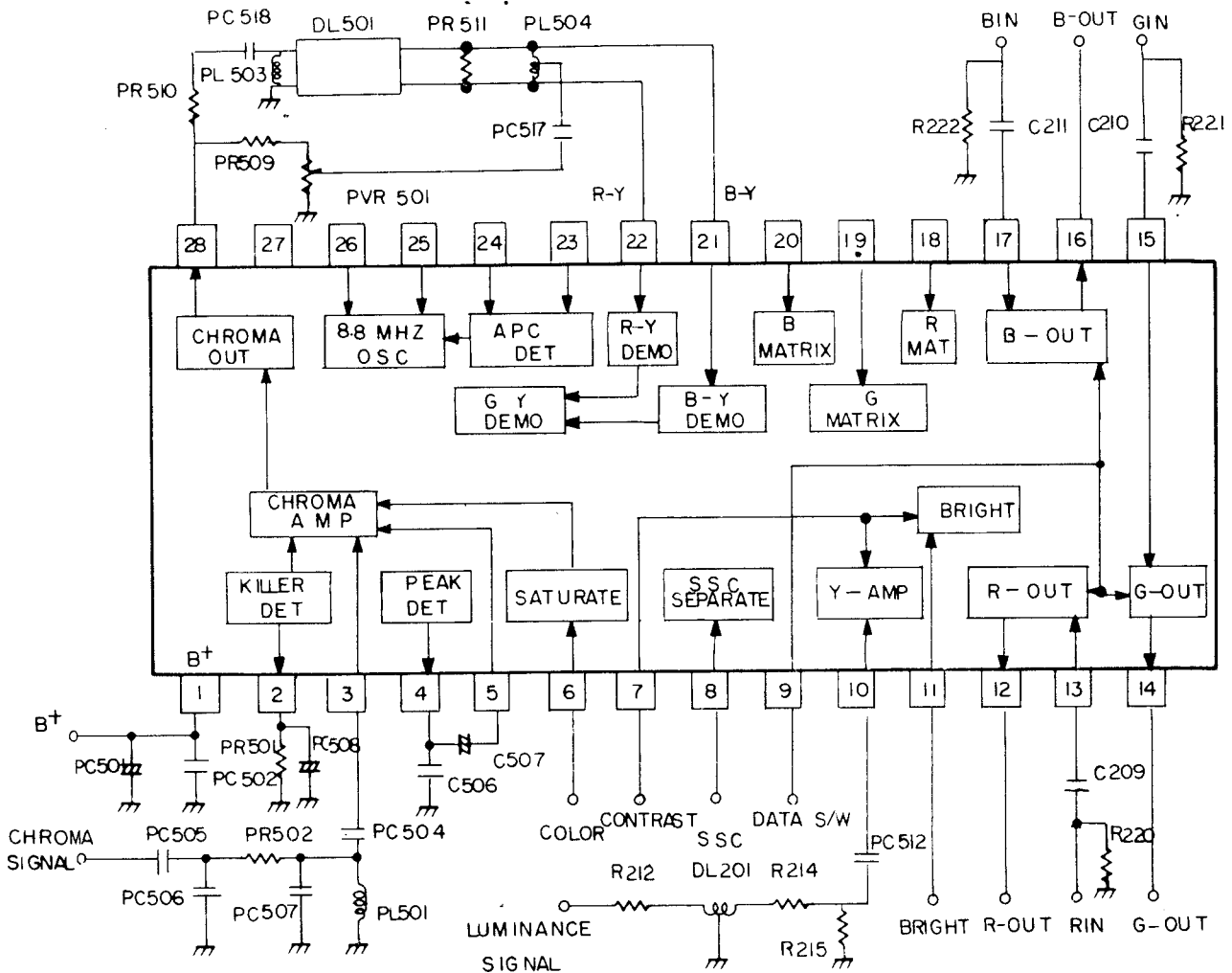

Figure 15. Schematic Diagram of PIC501 (TDA3560A)

5-1 Chroma Path

First, the chroma signal flows from B.P.F circuit into pin3 to be amplified, and then it flows into the second amplifier to be about 4Vp-p.

The amplifier signal output from pin28 is separated into two ways.

One flows through PR510, PC518 into 1H-Delay Line(DL501), the other flows through PR509, PVR501 and PC517 into mid-tap of PL504.

At PL504 two kinds of signal are vectored and adjusted, so that R-Y(u) signal is separated into B-Y(u) and B-Y(v). Each of the signals is demodulated inside pins21, 22, so that G-Y is generated by R-Y and B-Y.

In the course of demodulation, colour system is a carrier wave suppressed. Therefore pins25,26 oscillate to 8.86MHz to reconstitute a carrier wave.

The DC voltage the colour Burst of pins23,24 generates flows into oscillator for 8.86MHz and adjust the oscillating frequency and the false image so that they may coincide with original signal.

After 8.86MHz generated in this way decrease by half, R-Y and B-Y flow into G-Y demodulator in order to generate a complete demodulation.

On the other hand, pin2 discharges its duty of controlling the first amplifier of an outcome so that colour killer should not generate colour noise during receiving black and white signal or electric field less than 35dBm.

That is to say, pin4 detects the colour Burst and makes it generate DC voltage, which is supplied and controlled on pin2, and kills the DC voltage of pin2 less than 3V. Pin6 is a saturation control circuit.

5-2 Luminance Path

As much as chroma path needs to perform chroma signal, DL201 delays Luminance signal about 600nS, and then this flows into pin10 through PC512 and control contrast, brightness with pin7 and pin11 to be supplied for each of R.G.B matrix circuit luminance signal supplied on pin10 is commonly 0.5Vp-p.

5-3 R.G.B Data Input

When the DC voltage of pin9 is 1-3V, PIC501 is converted into it in data input and when each of R.G.B signals flows into pins 13,15,17 each signal is in output at pins 12,14,16. In case that DC voltage of pin9 remains less than 0.4V, normal state remains.

6. POWER SUPPLY (IC801, TDA4601)

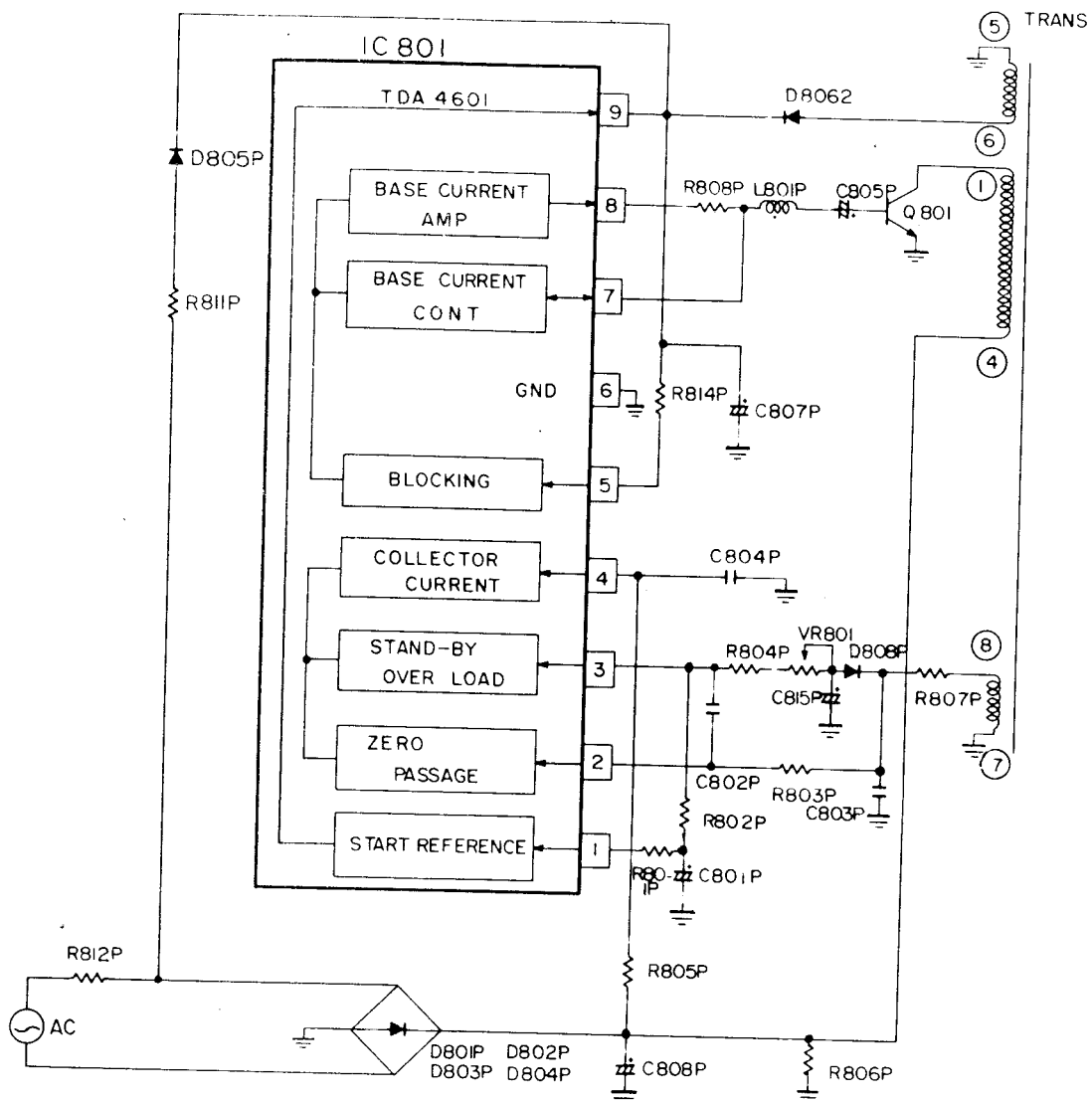

Figure 16. Schematic Diagram of IC801 (TDA4601)

6-1 Operating Description of the Circuit

START UP

If the power switch is ON, the voltage made by R811P, D805P and C807P, which is applied to pin9 of IC801.

If the voltage of pin9 is above 8.5V, IC801 begins the generation.

The voltage rectified by D801P, D802P, D803P, D804P and C808P, which is applied to pin4 of SMPS transformer (T801).

At this time, PWM signal outputs from pin7 of IC801 and drives Q801.

If Q801 is driven, the voltage generated at pins5,6 of SMPS TRANS is rectified at D806P and C807P, and supplies about 13V to pin9 of IC801 continually.

NORMAL OPERATION

The square wave output which make Q801 on and off flows out of pin8, and its extend is adjusted by pin7.

Also the sources generated by the load variation are detected from the wire wound pins7,8 of T801.

The detected variation sources which is commuted with the D808P and C815P input the voltage to pin3.

Pin2 and pin3 have the function assisting the control operation.

And VR801 controls the secondary output voltage.

OVER LOAD OPERATION

The maximum collector current is decided by R805P and C804P connected to the pin4. When this identified value is exceed over load operation, fix R805P for 270K ohm and change the value of C804P to adjust the maximum over load.

If you use a big capacitor of C804P, the maximum load electric power will increase.

HIGH VOLTAGE PROTECTION

This is decided by R814P connected at pin5 if the voltage of pin5 increase above the fixed voltage, the switching motion will stop.

TROUBLESHOOTING GUIDE

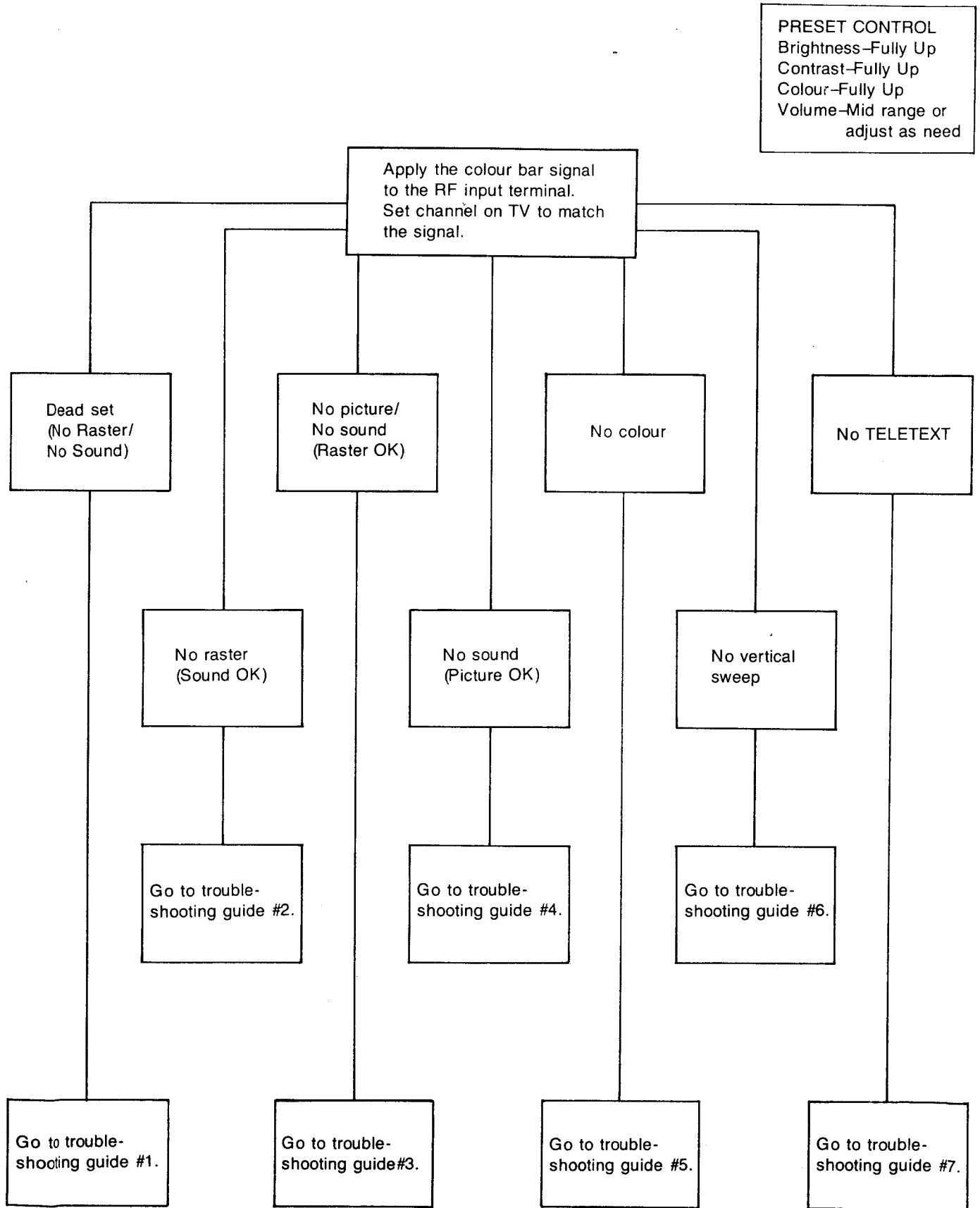

**#1. DEAD SET
(NO RASTER/NO SOUND)**

Check +B voltage at TP6. (J122)

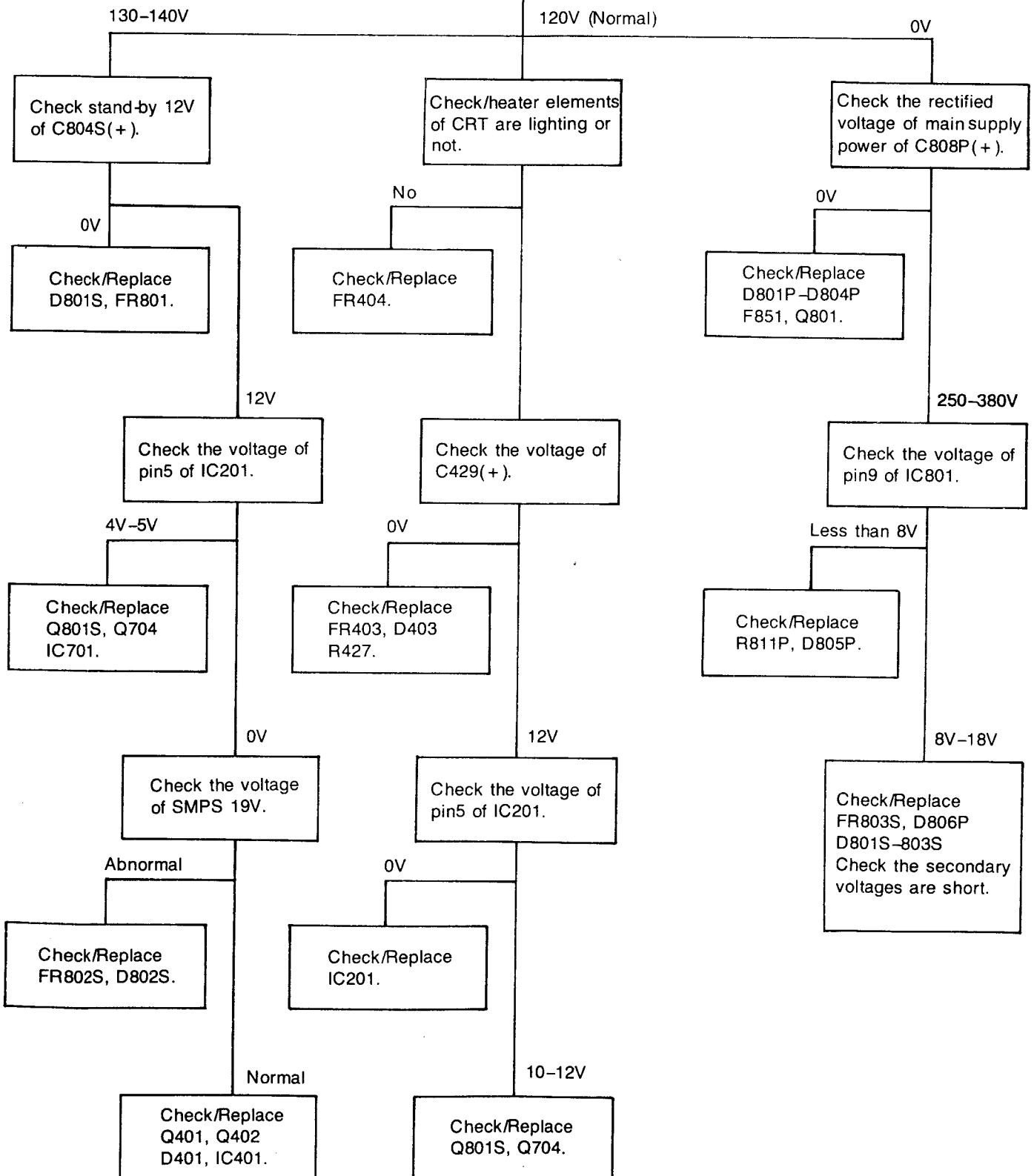

**#2. NO RASTER
(SOUND OK)**

Check/heater elements of
CRT are lighting.

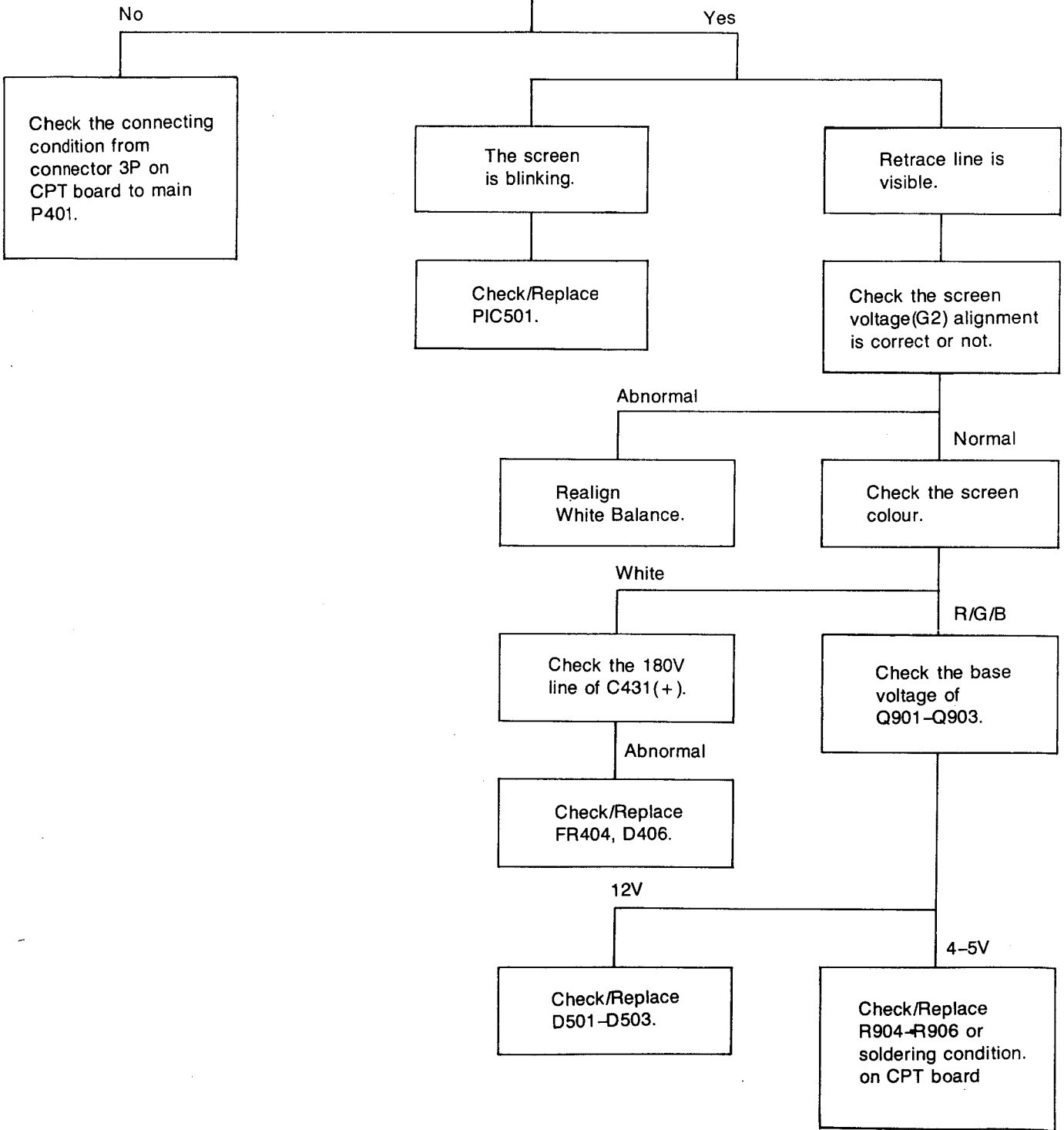

**#3. NO PICTURE/NO SOUND
(RASTER OK)**

Check the voltage of
TUNER MB. (12V)

11.8-12.2V

Check/Replace
TUNER.

Check the tuning
condition

Check/Replace
Q161.

Check the 33V line
of C425(+).

Check/Replace
FR428, ZD401.
D405.

**#4. NO SOUND
(PICTURE OK)**

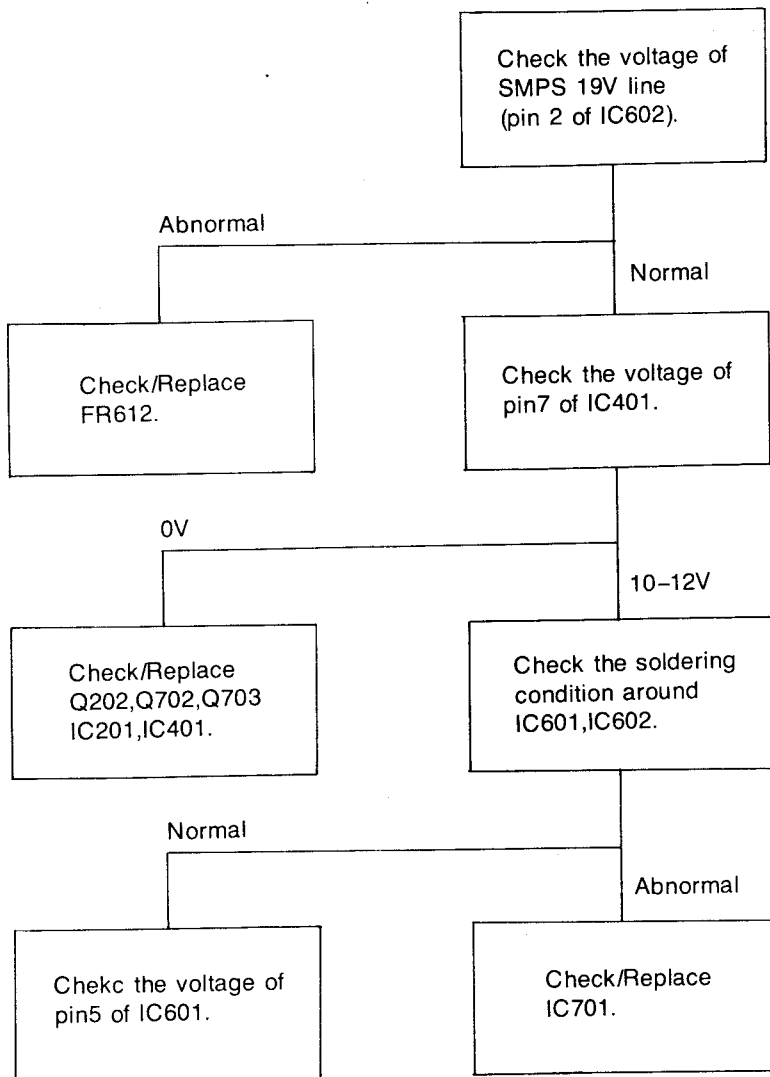

NOTE:

Sound is muted whenever the screen is noise condition, that is, broadcasting signal is not found.

#5. NO COLOUR

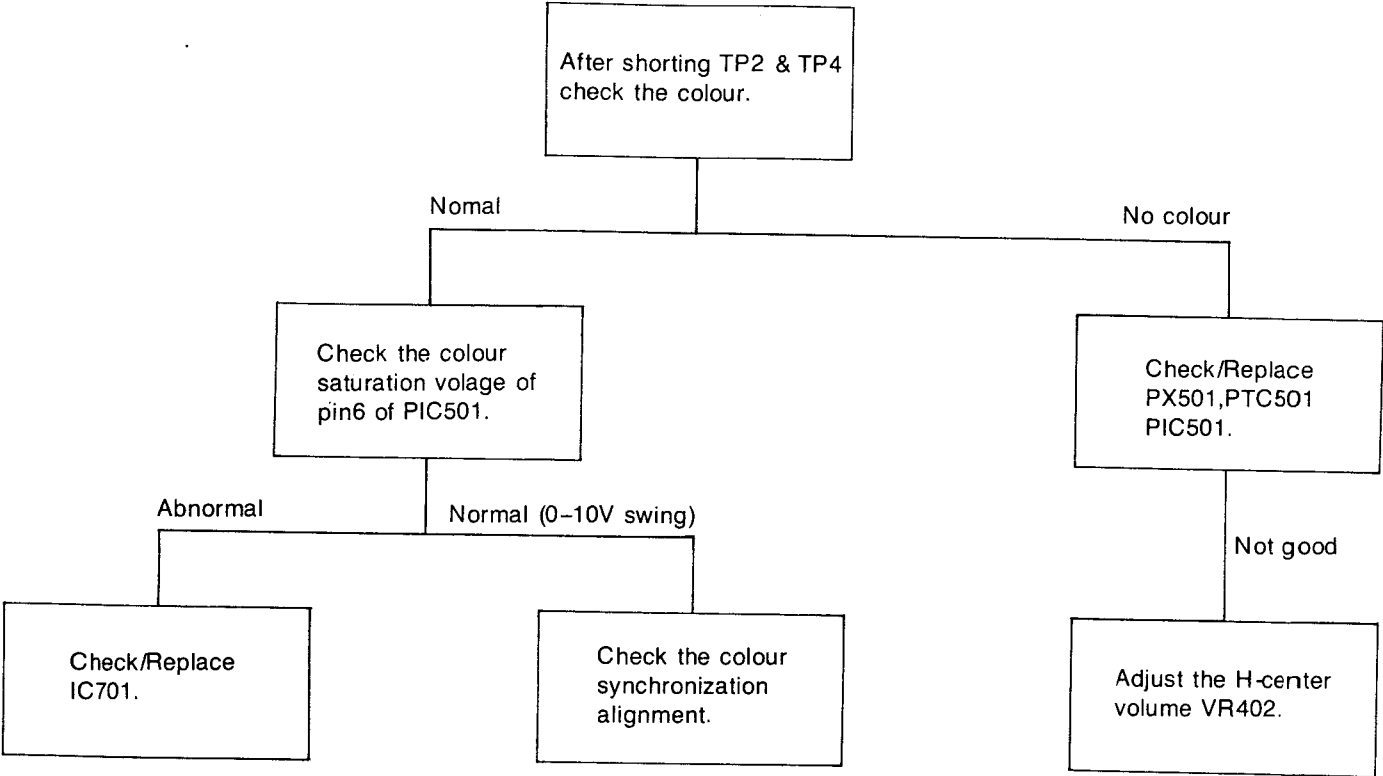

#6. NO VERTICAL SWEEP

Check the around IC301 soldering condition check/Replace IC301.

#7. NO TELETEXT

Check the voltage of C32(+).

11.8-12.2V

Abnormal

Check the Emitter voltage of Q1.

Check/Replace L6.

Abnormal

4.9-5V

Check/Replace Q1,ZD1.

Check the pin6 of P101 (CCVS signal)..

Yes

No

Check the pin 1,2 of P102 (SCL, SDA).

Check/whether A/V condition or NOT.

No

Check/Replace IC5,IC701 IC4, PCF8582. Check all the connection of SCL, SDA.

Yes

Check the pin2 of P101 (FB).

* If TELETEXT SYNC is not correct, the teletext picture be move to left or right, then readjust TC1 to be 6.0MHz.
* If TELETEXT data error occurs, readjust channel memory or VIF and AFT ALIGNMENT.

No

Check/Replace IC2.

Yes

Check the R.G.B connection from IC2 to PiC501 of main board.

BLOCK DIAGRAM

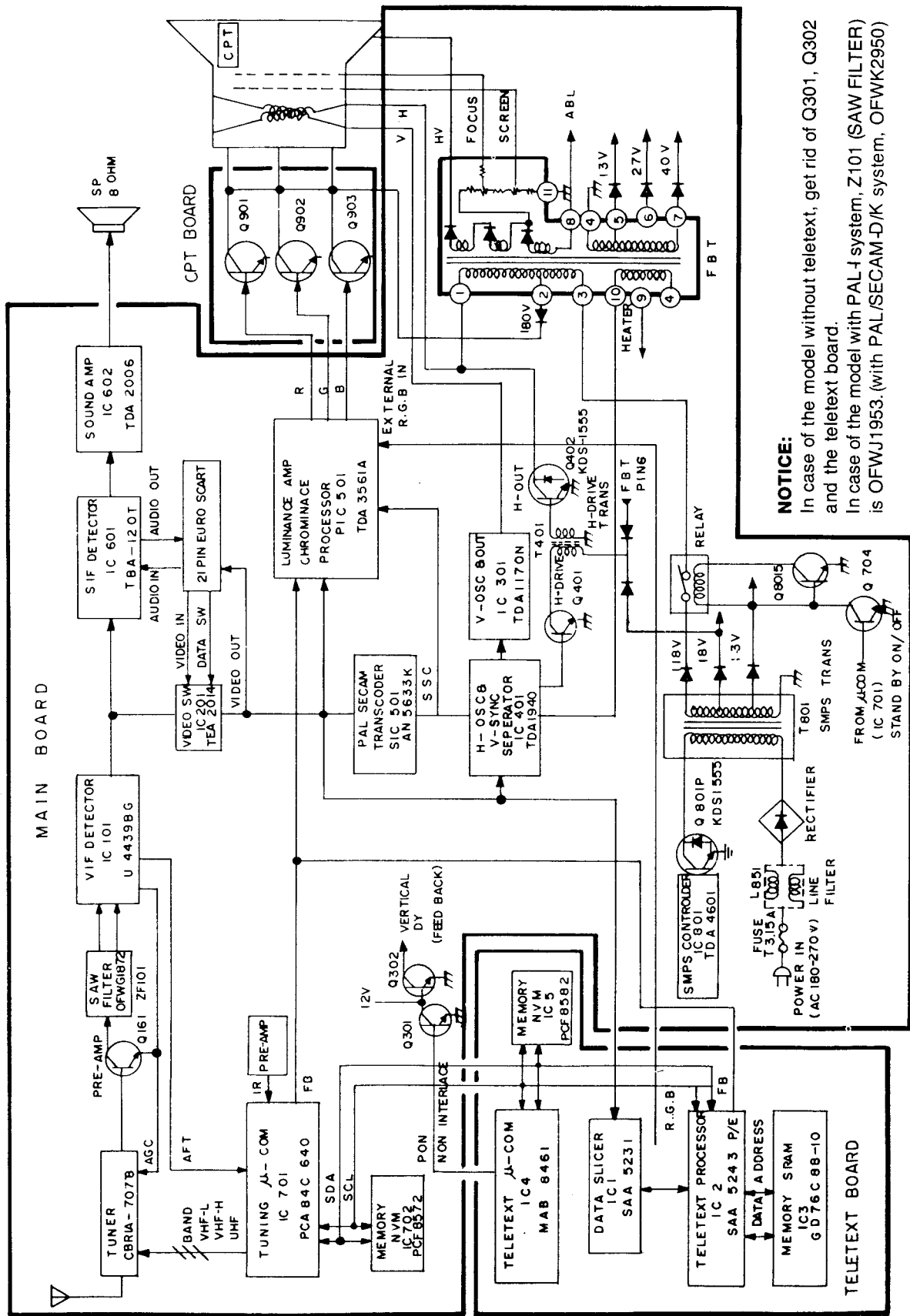

WIRING DIAGRAM

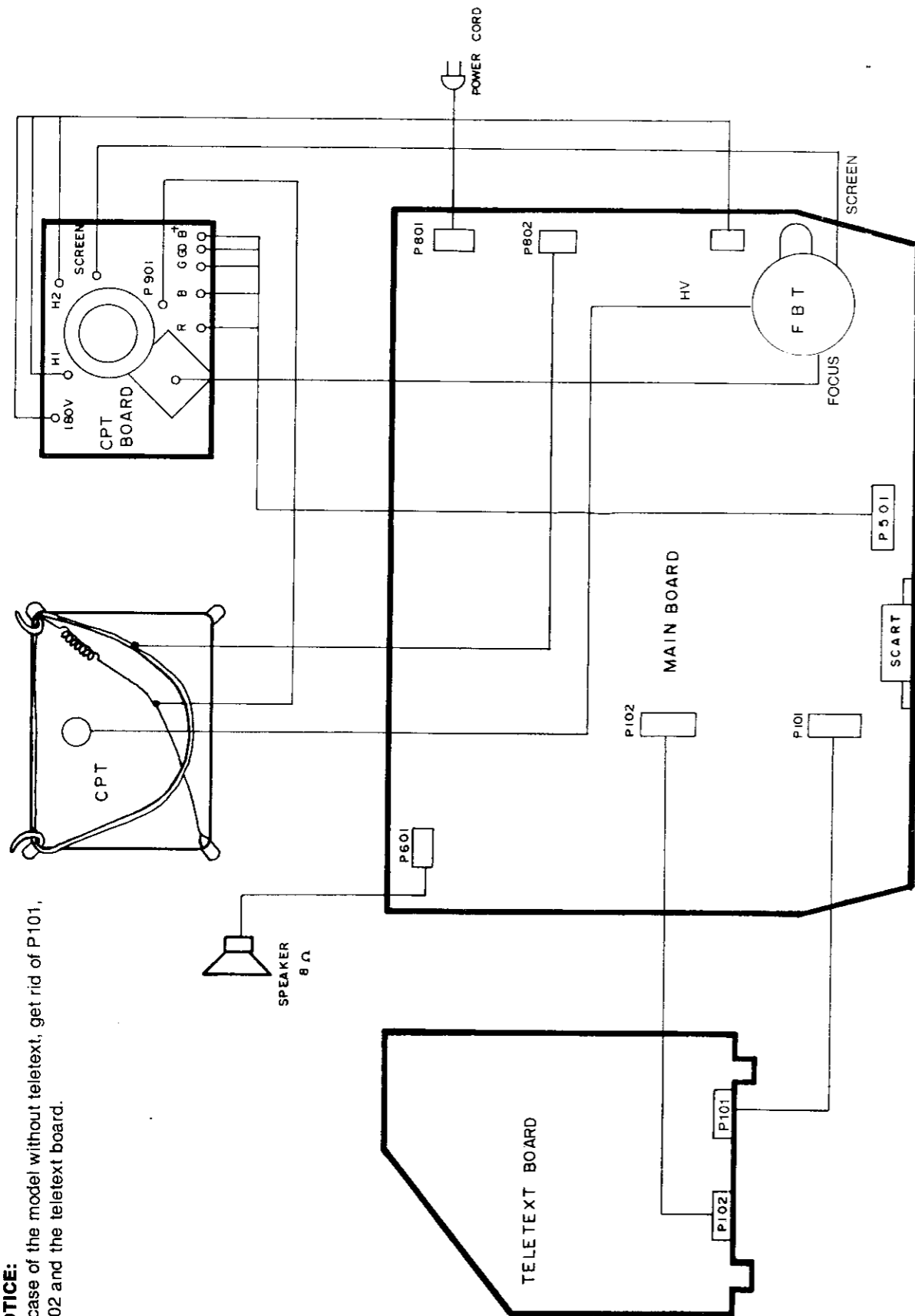

NOTICE:
In case of the model without teletext, get rid of P101, P102 and the teletext board.

TERMINAL VIEW OF SEMICONDUCTOR

DIODE

FIGURE	DESCRIPTION	REFERENCE NO.
	1N4148TA	D1-D8, D201, D203 D205, D206, D207 D208, D210, D601 D602, D603, D604 D701, D703 D704-D709 D901-D903, D804S PD502, 503, SD501
	1N4003TA	D301, D401, D402
	R10J	D404-D407, D801S D802S, D805S D805P-D808P
	RGP15J	D403, D408
	1N4005TA	D801P-D804P
	GU3C	D803S
	KA33V	ZD401
	HZ33T	
	Z5.6BM	ZD1, ZD701
	Z7.5BM	ZD402

TRANSISTOR

	2SD1555	Q402, Q801
	KTC1815-GR	Q403
	KTC1815-O/Y	Q201, Q202, Q301 Q302 Q701-Q709
	KTC388A	Q161
	KTA1015-O/Y	Q710, Q711, Q712 Q714
	KTC2230A	Q401
	KTC1959-Y	Q713, Q801S
	KTC2236A-O	Q1
	KTC2068	Q901-Q903

IC

	TDA4439 u4439BG	IC101
	TEA1014	IC201
	TDA1170N	IC301

FIGURE	DESCRIPTION	REFERENCE NO.
	TDA1940	IC401
	GD76C88-10	IC3
	TDA-3560B GD76C88-15	PIC501
	TDA-3560A	IC601
	TDA4601	IC801
	SAA5243P/E	IC2
	PCF84C640/030	IC701
	AN5633K	SIC501
	PCF84C640/030 PCD8582	IC5
	PCD85C72 PCD8572	IC702
	MAB8461	IC4
	SAA5231-2 SAA5231	IC1

COMPONENT LOCATION GUIDE

(Refer to page 33)

R101	2A	R319	2D	R702	1A	R761	5D	PR502	2B
R102	3A	R320	1D	R703	1A	R762	5D	PR503	2B
R104	2A	R401	2C	R704	1A	R763	4C	PR504	2C
R105	3A	R402	3E	R705	1A	R764	4C	PR505	1C
R106	2A	R403	2E	R706	1A	R765	4C	PR506	1C
R107	3A	R404	3E	R707	4B	R766	4C	PR507	1C
R108	3A	R405	2E	R708	4B	R767	4C	PR508	1D
R109	3A	R406	2D	R709	4B	R768	5D	PR509	2C
R110	3A	R408	4C	R710	3A	R769	4C	PR510	2C
R111	3A	R409	3C	R711	4B	R770	1B	PR511	1C
R112	1B	R410	1D	R712	5B	R771	4C	PR512	2C
R161	1A	R411	3C	R713	5B	R801S	3D	PVR501	2C
R162	2A	R412	3C	R714	5B	R802S	3D		
R163	2A	R413	3C	R715	5B	R804S	3D	C101	2A
R164	2A	R414	3C	R716	5B	R811S	3D	C102	3A
R165	2A	R415	3C	R717	5B	R801P	4D	C103	2A
R166	2A	R416	3C	R718	5C	R802P	4D	C104	2A
R167	2A	R417	3C	R719	5C	R803P	4D	C105	3A
R168	1A	R418	3C	R720	5C	R804P	4C	C106	3A
R169	1A	R419	3C	R721	5C	R805P	4D	C108	2A
R171	1A	R420	3C	R722	5C	R806P	5D	C109	2A
R172	2A	R421	3C	R723	5C	R807P	4D	C161	2A
R201	1B	R422	3C	R724	4C	R808P	5D	C162	2A
R202	1B	R423	3C	R725	5C	R809P	4E	C163	2A
R203	1B	R424	3C	R726	4C	R810P	4D	C164	2A
R205	4A	R425	3C	R727	4C	R811P	5D	C165	1A
R207	4A	R426	1E	R728	4B	R812P	4E	C166	1A
R208	3A	R427	1D	R729	4C	R813P	3E	C167	1A
R209	4A	R429	1E	R729	4C	R814P	5C	C168	1A
R210	1C	R430	1E	R730	4C	VR101	3A	C169	1A
R211	1C	R432	3C	R731	4C	VR301	2C	C170	1A
R212	1B	R433	3C	R732	4C	VR302	2C	C171	2A
R214	1B	R434	2C	R733	4B	VR303	1D	C201	1B
R215	1B	R435	4B	R734	4C	VR401	3C	C202	2B
R218	1B	R436	3C	R735	4C	VR701	4B	C203	2B
R219	1B	R437	1D	R736	4C	VR801	4C	C204	4A
R220	1B	R601	3A	R737	4B	FR401	1D	C206	4A
R221	1C	R602	4A	R738	5B	FR402	1D	C209	1C
R222	1C	R603	4A	R739	5B	FR403	1D	C210	1C
R225	1B	R604	4A	R740	5B	FR404	1E	C211	1C
R226	1B	R605	5A	R741	5B	FR405	2E	C212	1C
R227	1B	R606	5A	R742	5B	FR406	2E	C213	4A
R229	3B	R607	5A	R743	5B	FR407	2D	C214	3A
R301	1D	R608	5A	R744	5B	FR428	1D	C215	1B
R302	2D	R609	5A	R745	5B	FR801S	3D	C301	1D
R303	2D	R610	5A	R746	4B	FR802S	3D	C302	2D
R304	2D	R611	5A	R747	5B	FR803S	3D	C303	2D
R305	2D	R612	5B	R748	5B	SR501	3B	C304	2D
R306	2C	R613	4A	R749	5B	SR502	3B	C305	3D
R307	2D	R614	4A	R750	4B	SR503	3B	C306	2D
R308	2D	R615	5A	R751	4B	SR504	2B	C307	2D
R309	2D	R616	4A	R752	4B	SR505	2C	C308	2D
R310	2D	R617	5A	R753	4B	SR506	3B	C309	1D
R311	2D	R618	3A	R754	4C	SR507	3B	C310	1D
R312	3C	R619	3A	R755	5C	SR508	3B	C311	1D
R313	1D	R620	3A	R756	5C	SR509	3B	C401	3E
R314	1D	R621	4A	R757	5C	SR510	2B	C403	3E
R315	1D	R622	5A	R758	4B	SR513	2B	C404	3E
R316	2D	R623	5A	R759	4C	SVR501	3B	C405	2E
R318	2D	R701	1A	R760	4C	PR501	3C	C406	2D

C407	2D	C705	4C	PC521	2C	D805P	5D	L102	3A
C408	3C	C706	5C	PC522	1D	D806P	4D	L103	3A
C409	3C	C707	4C	SC501	3B	D807P	4D	L104	2A
C410	3C	C708	4B	SC502	3B	D808P	4C	L105	3A
C411	3C	C709	4B	SC504	3B	D801S	3D	L161	2A
C412	3C	C710	4B	SC505	3B	D802S	3D	L162	2A
C413	3C	C711	5B	SC506	3B	D803S	3D	L201	2B
C414	3C	C712	5B	SC507	3B	D804S	3D	L401	2D
C415	3C	C713	4B	SC508	3B	D805S	2C	L402	2E
C416	3C	C714	5B	SC509	2B	SD501	2C	L602	3A
C417	3C	C715	5D	SC510	2B	PD502	1C	L622	4A
C418	3C	C716	4C	SC511	2B	PD503	1D	L701	4C
C419	3C	C717	1B	SC512	2B	ZD401	1D	L801P	5D
C420	2C	C801P	4D	SC513	2B	ZD701	4C	L804S	3E
C421	2C	C802P	4C	SC514	2B	ZD702	4C	L851	5E
C422	1D	C803P	4D	SC515	3B	LD701	5D	PL501	2C
C423	2D	C804P	4D	SC516	3B			PL502	1B
C424	1E	C805P	4D	SC517	2B	T401	2E	PL503	2C
C425	1D	C806P	4D	SC518	3B	T801	4C	PL504	1C
C426	2D	C807P	5C	SC519	3B			SL501	3B
C427	1D	C808P	3E	SC520	3B	Q161	2A	SL503	3B
C428	1D	C809P	4E	SC521	3B	Q201	1B	SL504	3C
C429	1D	C810P	4E	SC523	3C	Q202	4A	SL505	3B
C430	1E	C811P	4E	SC524	3B	Q301	2D	SL506	3B
C431	2E	C812P	3E	SC525	3B	Q302	2D	DL201	1B
C432	2E	C814P	3E	SC526	2B	Q402	2E		
C522	3C	C815P	4C	PTC501	2C	Q403	4B	PA1	5E
C528	1C	C816P	3E			Q601	4A	P101	1B
C601	3A	C801S	3D	D201	1B	Q602	4A	P102	3B
C602	4A	C802S	3D	D203	1B	Q701	5B	P201	1B
C603	4A	C803S	3D	D204	1B	Q702	4B	P301	2D
C604	4A	C804S	3D	D205	4B	Q703	4B	P401	2E
C605	4A	C805S	3D	D206	4B	Q704	5C	P501	1C
C606	4A	C806S	3E	D207	2C	Q705	4C	P601	5A
C607	4A	C807S	3E	D210	3B	Q706	5D	P701	5C
C608	5A	C851	4E	D301	2D	Q707	1A	P702	5C
C609	4A	C852	4D	D401	3D	Q708	1A	P801	5E
C610	4A	C853	4E	D402	2E	Q709	1A	P802	4E
C611	5A	C854	5E	D403	1D	Q710	1A	PX501	2C
C612	5A	C855	5D	D404	2D	Q711	1A	X501	5A
C613	5A	PC501	2C	D405	1E	Q712	1A	X701	4C
C614	5A	PC502	2B	D406	2E	Q713	3D	F851	4E
C615	5A	PC503	2B	D407	4C	Q714	5D	SW301	2D
C616	5A	PC504	2B	D601	4A	Q715	4C	SW851	5E
C617	5A	PC505	2B	D602	5A	Q801S	3D	Z101	2A
C618	4A	PC506	1B	D603	4A	Q801P	4D	Z102	2A
C619	3A	PC507	1B	D604	4A			Z601	5A
C620	4A	PC508	2B	D701	5C	IC101	3A	Z602	4A
C621	4A	PC509	2C	D702	5C	IC201	2B	Z603	3A
C622	5A	PC510	2C	D703	5C	IC301	2D	Z604	3A
C623	4A	PC511	1C	D704	5C	IC401	3C	ZF101	2A
C624	4A	PC512	1C	D705	5C	IC601	4A	TH851	4E
C625	4A	PC513	1C	D706	5B	IC602	5A	RL801	3D
C626	4A	PC514	1C	D707	4B	IC701	5B	TP1	2A
C627	5A	PC515	1C	D708	5B	IC702	5C	TP2	2C
C628	3A	PC516	1C	D709	5B	IC801	4D	TP3	3C
C701	5B	PC517	2C	D801P	4E	SIC501	2B	TP4	2C
C702	5B	PC518	2C	D802P	4E	PIC501	1C	TP5	1C
C703	5B	PC519	2C	D803P	4E			TP6	1E
C704	4C	PC520	2C	D804P	4E	L101	2A		

MAIN P.C.BOARD (COMPONENT SIDE)

PRINTED CIRCUIT BOARD

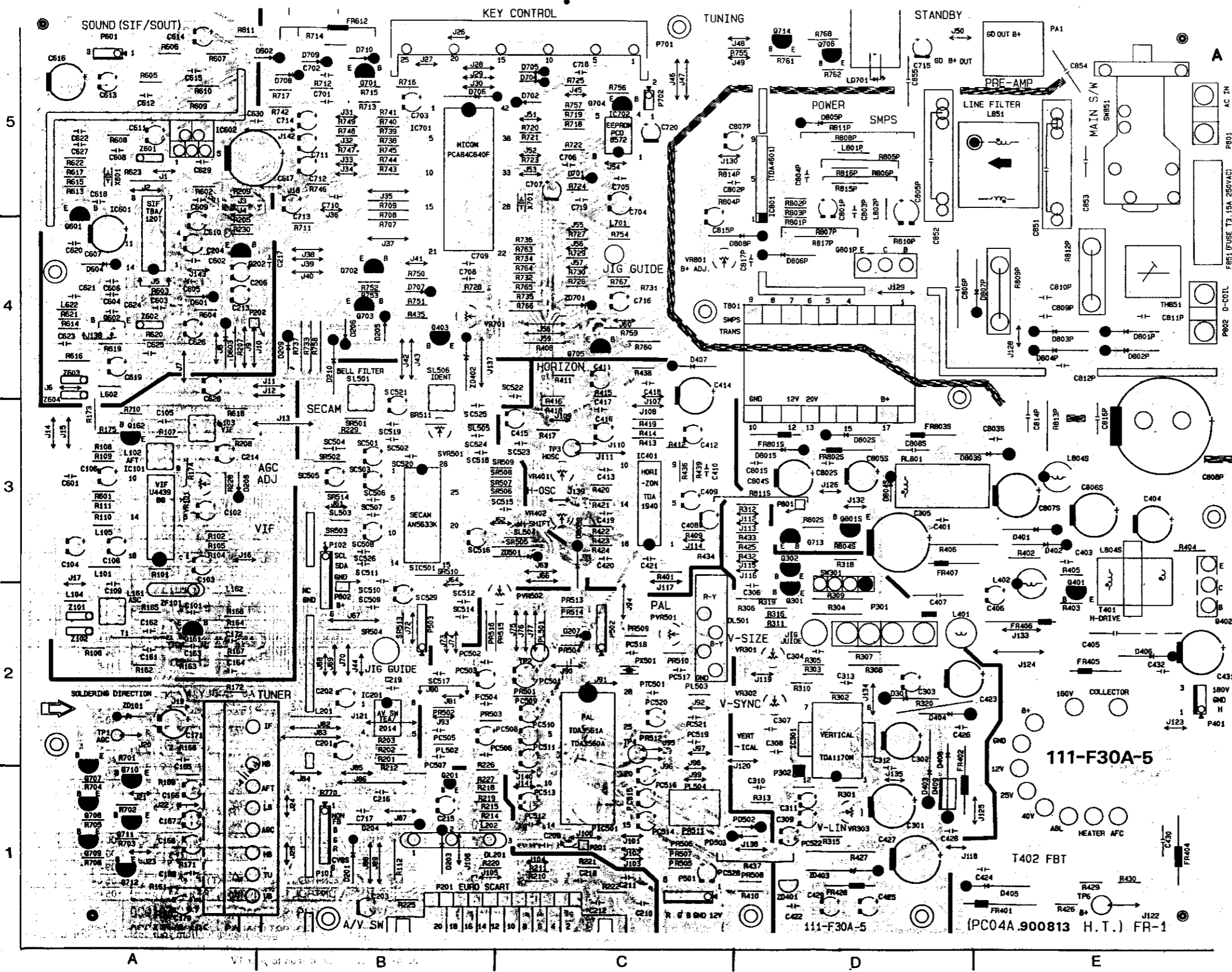

CPT P.C.BOARD (COMPONENT SIDE)

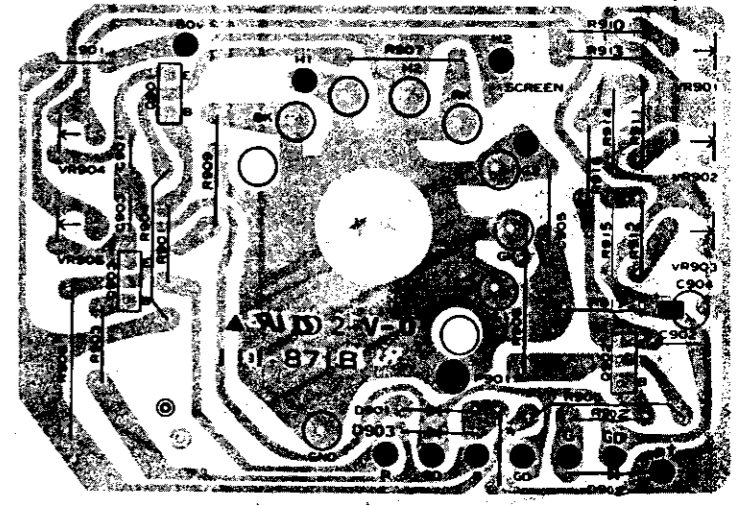

EXPLODED VIEW

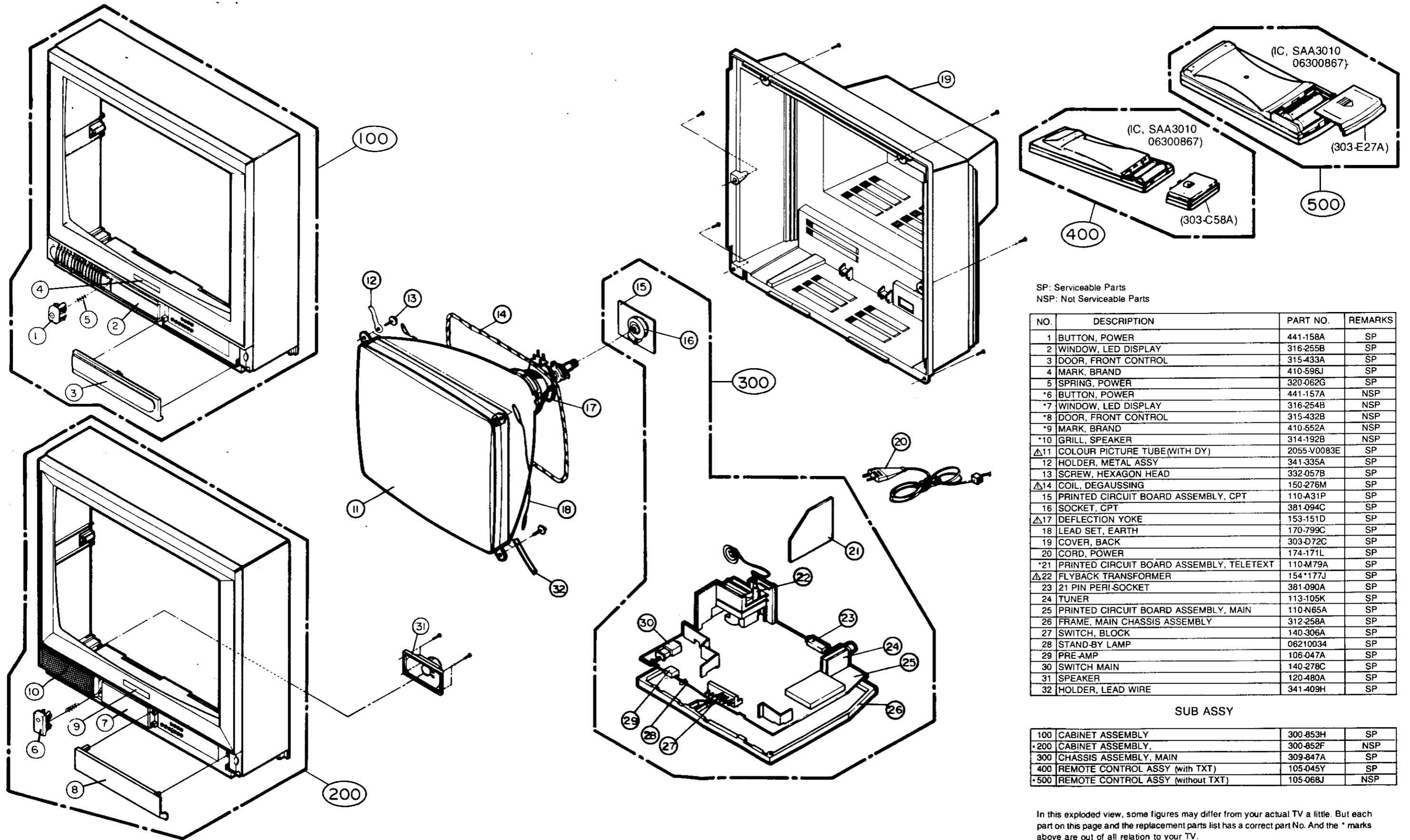

SP: Serviceable Parts
NSP: Not Serviceable Parts

NO.	DESCRIPTION	PART NO.	REMARKS
1	BUTTON, POWER	441-158A	SP
2	WINDOW, LED DISPLAY	316-255B	SP
3	DOOR, FRONT CONTROL	315-433A	SP
4	MARK, BRAND	410-596J	SP
5	SPRING, POWER	320-062G	SP
*6	BUTTON, POWER	441-157A	NSP
*7	WINDOW, LED DISPLAY	316-254B	NSP
*8	DOOR, FRONT CONTROL	315-432B	NSP
*9	MARK, BRAND	410-552A	NSP
*10	GRILL, SPEAKER	314-192B	NSP
△11	COLOUR PICTURE TUBE (WITH DY)	2055-V0083E	SP
12	HOLDER, METAL ASSY	341-335A	SP
13	SCREW, HEXAGON HEAD	332-057B	SP
△14	COIL, DEGAUSSING	150-276M	SP
15	PRINTED CIRCUIT BOARD ASSEMBLY, CPT	110-A31P	SP
16	SOCKET, CPT	381-094C	SP
△17	DEFLECTION YOKE	153-151D	SP
18	LEAD SET, EARTH	170-799C	SP
19	COVER, BACK	303-D72C	SP
20	CORD, POWER	174-171L	SP
*21	PRINTED CIRCUIT BOARD ASSEMBLY, TELETXT	110-M79A	SP
△22	FLYBACK TRANSFORMER	154*177J	SP
23	21 PIN PERI-SOCKET	381-090A	SP
24	TUNER	113-105K	SP
25	PRINTED CIRCUIT BOARD ASSEMBLY, MAIN	110-N65A	SP
26	FRAME, MAIN CHASSIS ASSEMBLY	312-258A	SP
27	SWITCH, BLOCK	140-306A	SP
28	STAND-BY LAMP	06210034	SP
29	PRE-AMP	106-047A	SP
30	SWITCH MAIN	140-278C	SP
31	SPEAKER	120-480A	SP
32	HOLDER, LEAD WIRE	341-409H	SP

SUB ASSY

100	CABINET ASSEMBLY	300-853H	SP
*200	CABINET ASSEMBLY,	300-852F	NSP
300	CHASSIS ASSEMBLY, MAIN	309-847A	SP
400	REMOTE CONTROL ASSY (with TXT)	105-045Y	SP
*500	REMOTE CONTROL ASSY (without TXT)	105-068J	NSP

In this exploded view, some figures may differ from your actual TV a little. But each part on this page and the replacement parts list has a correct part No. And the * marks above are out of all relation to your TV.

[REPLACEMENT PARTS LIST]

PAGE : 1

MODEL : CBZ-9825F BPHRO

BUYER NAME : OTTO VERSAND

RUN-DATE : 90.10.23

- CAUTION:** 1. Before replacing any of these components, read carefully the "SAFETY PRECAUTIONS" on page 3. Do not degrade the safety of the receiver through improper servicing.
 2. When ordering the service parts, put this service manual No., page and your requesting parts No. on your document correctly, please. Then, we'll send the parts to you faster.

S	AL	LOCA.NO	PART NO(GS)	DESCRIPTION	SPECIFICATION	REMARKS
			0IIT301000A	IC, ITT	SAA3010(PC04A,TX)	
			105-045Y	TRANSMITTER	ASSY,T-22(PC04A)W/TXT	
			110-A31P	PWB ASSY	CPT PC09X2 19"(ONE BOARD)	
			110-M79A	PCB ASSY	TXT(PC04A,FAST)	
			110-N65A	PCB ASSY	MAIN(9902,B/G,FTZ,TXT,A/V)	
			113-105K	TUNER	CER1A-707B(ALPS),PAL B/G	
			120-C42A	SPEAKER	ASSY,CBT-9822/9825	
			120-480A	SPEAKER	C112PX-716K14	
			140-306A	SWITCH	BLOCK,RK09VAA10-SWX11(G/S)	
△			150-276M	COIL	DEGAUSSING,19"(D) SHORT LEAD	
△			153-151D	DY	DCAM*151D-20PLAA	
			174-171L	CORD	ASSY POWER (PC004A)	
			174-179B	CORD	DW-1	
△			2055-V0083E	CPT	A48KCS12XX 25N7KE	
			300-853H	CABINET ASSY	CBZ-9825,HANSEATIC	
			303-C58A	COVER	BATTERY(T-22,3V)	
			303-D72C	COVER	ASSY,BACK(CBT-9902/5 NEW ALPS	
			305-002D	HOUSING	2P AMP 171157-1 (10)	
			309-847A	CHASSIS ASSY	MAIN PC04A(9902/05)	
			312-258A	FRAME	MAIN CHASSIS (PC91A)	
			315-433A	DOOR	ASSY,CONTROL CBT-9825	
			316-255B	WINDOW	CH. DISPLAY	
			320-062G	SPRING	KNOB	
			341-242F	HOLDER	POWER CORD	
			343-854D	SUPPORTER	PWB	
			371-744A	PACKING	TOP CBT-9822/9825	
			371-745A	PACKING	BOTTOM CBT-9822/9825	
			371-750A	PACKING	FRONT (CBT-9822/25)	
			372-K41B	BOX	INNER CBZ-9825F BPHRO	
			381-090A	SOCKET ASSY	21PIN PERI-SOCKET	
			381-094C	SOCKET	PCS-624	
			407-674D	PLATE	CONTROL	
			410-569J	MARK	BRAND(HANSEATIC)	
			441-158A	BUTTON	POWER(CBT-9825)	
			450-A01A	ADAPTER	ANTENNA	
			482-E59C	INSTRUCTIONS(OWNER'S MANUAL)	CBZ-9825F BPHRO	
	C1		OCE1076F618	CAPACITOR,ELECTROLYTIC	100M SMS 16V M FM5 TP(5)	
	C10		OCE1076F618	CAPACITOR,ELECTROLYTIC	100M SMS 16V M FM5 TP(5)	
	C101		OCK1020K515	CAPACITOR,CERAMIC(HIGH DIELE)	1000P 50V K B TS	
	C102		OCE4756K618	CAPACITOR,ELECTROLYTIC	4.7M SMS 50V M FL TP(5)	
	C103		OCE2256K618	CAPACITOR,ELECTROLYTIC	2.2M SMS 50V M FL TP(5)	
	C104		OCE1076F618	CAPACITOR,ELECTROLYTIC	100M SMS 16V M FM5 TP(5)	
	C105		OCC1500K415	CAPACITOR,CERAMIC(TEMP COMP)	15P 50V J NP0 TS	
	C106		OCE2256K618	CAPACITOR,ELECTROLYTIC	2.2M SMS 50V M FL TP(5)	
	C108		OCE4766F618	CAPACITOR,ELECTROLYTIC	47M SMS 16V M FL TP(5)	
	C109		OCK1030K945	CAPACITOR,CERAMIC(HIGH DIELE)	0.01M 50V Z F TS	
	C11		OCK1030K945	CAPACITOR,CERAMIC(HIGH DIELE)	0.01M 50V Z F TS	
	C12		OCK1030K945	CAPACITOR,CERAMIC(HIGH DIELE)	0.01M 50V Z F TS	
	C13		OCE2256K618	CAPACITOR,ELECTROLYTIC	2.2M SMS 50V M FL TP(5)	

[REPLACEMENT PARTS LIST]

PAGE : 2

MODEL : CBZ-9825F BPHRO

BUYER NAME : OTTO VERSAND

RUN-DATE : 90.10.23

S	AL	LOCA.NO	PART NO(GS)	DESCRIPTION	SPECIFICATION	REMARKS
		C14	OCC2700K415	CAPACITOR CERAMIC(TEMP COMP)	27P 50V J NPO TP	
		C15	OCC1500K415	CAPACITOR,CERAMIC(TEMP COMP)	15P 50V J NPO TS	
		C16	OCC1010K415	CAPACITOR,CERAMIC(TEMP COMP)	100P 50V J NPO TS	
		C163	OCC1030K945	CAPACITOR,CERAMIC(HIGH DIELE)	0.01M 50V Z F TS	
		C164	OCC1030K945	CAPACITOR,CERAMIC(HIGH DIELE)	0.01M 50V Z F TS	
		C165	OCC1030K945	CAPACITOR,CERAMIC(HIGH DIELE)	0.01M 50V Z F TS	
		C166	OCE1066F618	CAPACITOR,ELECTROLYTIC	10M SMS 16V M FM5 TP(5)	
		C167	OCE1066F618	CAPACITOR,ELECTROLYTIC	10M SMS 16V M FM5 TP(5)	
		C168	OCE1066F618	CAPACITOR,ELECTROLYTIC	10M SMS 16V M FM5 TP(5)	
		C169	OCQ1041N509	CAPACITOR POLYESTER(MYLAR)	0.1U 100V K POLY TP	
		C17.	OCC2710K405	CAPACITOR CERAMIC(TEMP COMP)	270PF 50V 5 SL FM(5MM)	
		C170	OCE4756K618	CAPACITOR,ELECTROLYTIC	4.7M SMS 50V M FL TP(5)	
		C171	OCE1076F618	CAPACITOR,ELECTROLYTIC	100M SMS 16V M FM5 TP(5)	
		C18	OCQ2231N509	CAPACITOR POLYESTER(MYLAR)	0.022U 100V K POLY TP	
		C19	OCC4710K515	CAPACITOR CERAMIC(HIGH DIELE)	470P 50V K B TS	
		C2	OCC1030K945	CAPACITOR,CERAMIC(HIGH DIELE)	0.01M 50V Z F TS	
		C20	OCQ1021N509	CAPACITOR POLYESTER(MYLAR)	0.001U 100V K POLY TP	
		C201	OCE1066F618	CAPACITOR,ELECTROLYTIC	10M SMS 16V M FM5 TP(5)	
		C202	OCE1066F618	CAPACITOR,ELECTROLYTIC	10M SMS 16V M FM5 TP(5)	
		C203	OCE4756K618	CAPACITOR,ELECTROLYTIC	4.7M SMS 50V M FL TP(5)	
		C204	OCE4756K618	CAPACITOR,ELECTROLYTIC	4.7M SMS 50V M FL TP(5)	
		C206	OCE4756K618	CAPACITOR,ELECTROLYTIC	4.7M SMS 50V M FL TP(5)	
		C209	OCQ1041N509	CAPACITOR POLYESTER(MYLAR)	0.1U 100V K POLY TP	
		C21	OCC1500K415	CAPACITOR,CERAMIC(TEMP COMP)	15P 50V J NPO TS	
		C210	OCQ1041N509	CAPACITOR POLYESTER(MYLAR)	0.1U 100V K POLY TP	
		C211	OCQ1041N509	CAPACITOR POLYESTER(MYLAR)	0.1U 100V K POLY TP	
		C213	OCE4756K618	CAPACITOR,ELECTROLYTIC	4.7M SMS 50V M FL TP(5)	
		C214	OCE1066K618	CAPACITOR,ELECTROLYTIC	10M SMS 50V M FM5 TP(5)	
		C215	OCE4756K618	CAPACITOR,ELECTROLYTIC	4.7M SMS 50V M FL TP(5)	
		C216	OCC5610K405	CAPACITOR CERAMIC(TEMP COMP)	560P 50V J SL TS	
		C217	OCQ1031N509	CAPACITOR POLYESTER(MYLAR)	0.01U 100V K POLY TP	
		C218	OCC1030K945	CAPACITOR,CERAMIC(HIGH DIELE)	0.01M 50V Z F TS	
		C219	181-416E	CAPACITOR	ECQV1H474JZ3,TR	
		C22	OCC2220K515	CAPACITOR CERAMIC(HIGH DIELE)	2200P 50V K B TS	
		C23	OCC2700K415	CAPACITOR CERAMIC(TEMP COMP)	27P 50V J NPO TP	
		C24	OCC2700K415	CAPACITOR CERAMIC(TEMP COMP)	27P 50V J NPO TP	
		C25	OCE1056K618	CAPACITOR,ELECTROLYTIC	1.0M SMS 50V M FL TP(5)	
		C26	OCE1076F618	CAPACITOR,ELECTROLYTIC	100M SMS 16V M FM5 TP(5)	
		C27	OCC1030K945	CAPACITOR,CERAMIC(HIGH DIELE)	0.01M 50V Z F TS	
		C28	OCC1010K415	CAPACITOR,CERAMIC(TEMP COMP)	100P 50V J NPO TS	
		C29	OCC1010K415	CAPACITOR,CERAMIC(TEMP COMP)	100P 50V J NPO TS	
		C3	OCE1076F618	CAPACITOR,ELECTROLYTIC	100M SMS 16V M FM5 TP(5)	
		C30	OCC1010K415	CAPACITOR,CERAMIC(TEMP COMP)	100P 50V J NPO TS	
		C301	181-221H	CAPACITOR	CE(MINI) 35V 1000UF	
		C302	181-081G	C.ELECTROLYTIC	100MF/35V	
		C303	OCE4756K618	CAPACITOR,ELECTROLYTIC	4.7M SMS 50V M FL TP(5)	
		C304	OCQ3331N509	CAPACITOR POLYESTER(MYLAR)	0.033U 100V K POLY TP	
		C305	OCE4776H630	CAPACITOR,ELECTROLYTIC	470M SMS 25V M FM5	
		C306	OCQ1041N509	CAPACITOR POLYESTER(MYLAR)	0.1U 100V K POLY TP	
		C307	OCQ1041N509	CAPACITOR POLYESTER(MYLAR)	0.1U 100V K POLY TP	
		C308	OCQ1041N509	CAPACITOR POLYESTER(MYLAR)	0.1U 100V K POLY TP	

REPLACEMENT PARTS LIST

PAGE : 3

MODEL : CBZ-9825F BPHRO

BUYER NAME : OTTO VERSAND

RUN-DATE : 90.10.23

S	AL	LOCA.NO	PART NO(GS)	DESCRIPTION	SPECIFICATION	REMARKS
		C309	181-032H	C,TANTALR	0.22MF/35V	
		C31	OCC1010K415	CAPACITOR,CERAMIC(TEMP COMP)	100P 50V J NPO TS	
		C310	OCC2231N509	CAPACITOR POLYESTER(MYLAR)	0.022U 100V K POLY TP	
		C311	181-032H	C,TANTALR	0.22MF/35V	
		C312	OCC1030K945	CAPACITOR,CERAMIC(HIGH DIELE)	0.01M 50V Z F TS	
		C313	OCC1030K945	CAPACITOR,CERAMIC(HIGH DIELE)	0.01M 50V Z F TS	
		C32	OCE4766F618	CAPACITOR,ELECTROLYTIC	47M SMS 16V M FL TP(5)	
		C33	OCC2710K405	CAPACITOR CERAMIC(TEMP COMP)	270PF 50V 5 SL FM(5MM)	
		C4	OCC1030K945	CAPACITOR,CERAMIC(HIGH DIELE)	0.01M 50V Z F TS	
		C401	OCC1041N509	CAPACITOR POLYESTER(MYLAR)	0.1U 100V K POLY TP	
		C403	OCC4721N509	CAPACITOR POLYESTER(MYLAR)	0.0047U 100V K POLY TP	
		C404	181-081G	C,ELECTROLYTIC	100MF/35V	
		C405	181-131G	C,METAL POLYPROPYLENE	9100PF/1.6KV	
Δ		C406	OCE1051P618	CAPACITOR,ELECTROLYTIC	1.0M SM 160V M FM5 TP5	
		C407	181-128B	C,METAL POLYPROPYLENE	0.47MF/200V J	
		C408	181-416E	CAPACITOR	ECQV1H474JZ3,TR	
		C409	OCE2246K618	CAPACITOR,ELECTROLYTIC	0.22M SMS 50V M FM5 TP(5)	
		C410	OCC1031N509	CAPACITOR POLYESTER(MYLAR)	0.01U 100V K POLY TP	
		C411	OCE1066F618	CAPACITOR,ELECTROLYTIC	10M SMS 16V M FM5 TP(5)	
		C412	OCE1066K618	CAPACITOR,ELECTROLYTIC	10M SMS 50V M FM5 TP(5)	
		C413	OCC1010K415	CAPACITOR,CERAMIC(TEMP COMP)	100P 50V J NPO TS	
		C414	OCE1086F630	CAPACITOR,ELECTROLYTIC	1000M SMS 16V M FM5	
		C416	OCE1046K618	CAPACITOR,ELECTROLYTIC	0.1M SMS 50V M FL TP(5)	
		C417	OCC2231N509	CAPACITOR POLYESTER(MYLAR)	0.022U 100V K POLY TP	
		C418	OCC1030K945	CAPACITOR,CERAMIC(HIGH DIELE)	0.01M 50V Z F TS	
		C419	181-095A	CAPACITOR	CAPACITOR,PE 100V 0.01MFJ	
		C420	OCC1041N509	CAPACITOR POLYESTER(MYLAR)	0.1U 100V K POLY TP	
		C421	OCC1041N509	CAPACITOR POLYESTER(MYLAR)	0.1U 100V K POLY TP	
		C422	OCE1056K618	CAPACITOR,ELECTROLYTIC	1.0M SMS 50V M FL TP(5)	
		C423	181-081G	C,ELECTROLYTIC	100MF/35V	
		C424	OCC2710W515	CAPACITOR CERAMIC(HIGH DIELE)	270P 500V K B TS	
		C425	OCE4756K618	CAPACITOR,ELECTROLYTIC	4.7M SMS 50V M FL TP(5)	
		C426	OCC2710W515	CAPACITOR CERAMIC(HIGH DIELE)	270P 500V K B TS	
		C427	OCE1086F630	CAPACITOR,ELECTROLYTIC	1000M SMS 16V M FM5	
		C428	OCC2710W515	CAPACITOR CERAMIC(HIGH DIELE)	270P 500V K B TS	
		C429	OCE4766F618	CAPACITOR,ELECTROLYTIC	47M SMS 16V M FL TP(5)	
		C430	181-059D	C,POLYPROYLENE	0.047MF/200V K	
		C431	OCE4751R630	CAPACITOR,ELECTROLYTIC	4.7M SM 250V M FM5	
		C432	OCC2710W515	CAPACITOR CERAMIC(HIGH DIELE)	270P 500V K B TS	
		C5	OCC6831N509	CAPACITOR POLYESTER(MYLAR)	0.068M 100V K POLY TP	
		C6	OCC2210K415	CAPACITOR CERAMIC(TEMP COMP)	220P 50V J NPO TP	
		C601	OCC4700K415	CAPACITOR CERAMIC(TEMP COMP)	47P 50V J NPO TP	
		C602	OCC2231N509	CAPACITOR POLYESTER(MYLAR)	0.022U 100V K POLY TP	
		C603	OCC1030K945	CAPACITOR,CERAMIC(HIGH DIELE)	0.01M 50V Z F TS	
		C604	OCC2231N509	CAPACITOR POLYESTER(MYLAR)	0.022U 100V K POLY TP	
		C605	OCC3331N509	CAPACITOR POLYESTER(MYLAR)	0.033U 100V K POLY TP	
		C606	OCC1030K945	CAPACITOR,CERAMIC(HIGH DIELE)	0.01M 50V Z F TS	
		C607	OCE4776F630	CAPACITOR,ELECTROLYTIC	470M SMS 16V M FM5	
		C608	OCC1031N509	CAPACITOR POLYESTER(MYLAR)	0.01U 100V K POLY TP	
		C609	OCC3310K405	CAPACITOR CERAMIC(TEMP COMP)	330P 50V J SL TS	

[REPLACEMENT PARTS LIST]

PAGE : 4

MODEL : CBZ-9825F BPHRO

BUYER NAME : OTTO VERSAND

RUN-DATE : 90.10.23

S	AL	LOCA.NO	PART NO(GS)	DESCRIPTION	SPECIFICATION	REMARKS
		C610	OCE1066F618	CAPACITOR,ELECTROLYTIC	10M SMS 16V M FM5 TP(5)	
		C611	OCE4756K618	CAPACITOR,ELECTROLYTIC	4.7M SMS 50V M FL TP(5)	
		C612	OCQ2231N509	CAPACITOR POLYESTER(MYLAR)	0.022U 100V K POLY TP	
		C613	OCE1066H618	CAPACITOR,ELECTROLYTIC	10M SMS 25V M FM5 TP(5)	
		C614	OCE2256K618	CAPACITOR,ELECTROLYTIC	2.2M SMS 50V M FL TP(5)	
		C615	OCQ1041N509	CAPACITOR POLYESTER(MYLAR)	0.1U 100V K POLY TP	
		C616	OCE4776F630	CAPACITOR,ELECTROLYTIC	470M SMS 16V M FM5	
		C617	181-221H	CAPACITOR	CE(MINI) 35V 1000UF	
		C621	OCK1030K945	CAPACITOR,CERAMIC(HIGH DIELE)	0.01M 50V Z F TS	
		C624	OCK1030K945	CAPACITOR,CERAMIC(HIGH DIELE)	0.01M 50V Z F TS	
		C626	OCE1066K618	CAPACITOR,ELECTROLYTIC	10M SMS 50V M FM5 TP(5)	
		C628	OCE1066K618	CAPACITOR,ELECTROLYTIC	10M SMS 50V M FM5 TP(5)	
		C629	181-416E	CAPACITOR	ECQV1H474JZ3,TR	
		C630	OCK1030K945	CAPACITOR,CERAMIC(HIGH DIELE)	0.01M 50V Z F TS	
		C7	OCQ4731N409	CAPACITOR POLYESTER(MYLAR)	0.047U 100V J POLY TP	
		C701	OCQ1041N509	CAPACITOR POLYESTER(MYLAR)	0.1U 100V K POLY TP	
		C702	OCQ1041N509	CAPACITOR POLYESTER(MYLAR)	0.1U 100V K POLY TP	
		C703	OCE4756K618	CAPACITOR,ELECTROLYTIC	4.7M SMS 50V M FL TP(5)	
		C704	OCE1086F630	CAPACITOR,ELECTROLYTIC	1000M SMS 16V M FM5	
		C705	OCK1030K945	CAPACITOR,CERAMIC(HIGH DIELE)	0.01M 50V Z F TS	
		C706	OCQ3321N509	CAPACITOR POLYESTER(MYLAR)	0.0033U 100V K POLY TP	
		C707	OCE3366F618	CAPACITOR,ELECTROLYTIC	33M SMS 16V M FL TP(5)	
		C709	OCC2700K415	CAPACITOR CERAMIC(TEMP COMP)	27P 50V J NPO TP	
		C710	OCQ1031N509	CAPACITOR POLYESTER(MYLAR)	0.01U 100V K POLY TP	
		C711	OCE4756K618	CAPACITOR,ELECTROLYTIC	4.7M SMS 50V M FL TP(5)	
		C712	OCE4756K618	CAPACITOR,ELECTROLYTIC	4.7M SMS 50V M FL TP(5)	
		C713	OCE4756K618	CAPACITOR,ELECTROLYTIC	4.7M SMS 50V M FL TP(5)	
		C714	OCE4746K618	CAPACITOR,ELECTROLYTIC	0.47M SMS 50V M FL TP(5)	
		C715	OCE1066F618	CAPACITOR,ELECTROLYTIC	10M SMS 16V M FM5 TP(5)	
		C716	OCE4756K618	CAPACITOR,ELECTROLYTIC	4.7M SMS 50V M FL TP(5)	
		C717	OCK5610K515	CAPACITOR CERAMIC(HIGH DIELE)	560P 50V K B TS	
		C718	OCK1030K945	CAPACITOR,CERAMIC(HIGH DIELE)	0.01M 50V Z F TS	
		C719	OCK1030K945	CAPACITOR,CERAMIC(HIGH DIELE)	0.01M 50V Z F TS	
		C720	OCE1056K618	CAPACITOR,ELECTROLYTIC	1.0M SMS 50V M FL TP(5)	
		C8	OCC1800K415	CAPACITOR,CERAMIC(TEMP COMP)	18P 50V J NPO TP	
		C801P	OCE1066F618	CAPACITOR,ELECTROLYTIC	10M SMS 16V M FM5 TP(5)	
		C801S	OCK2710W515	CAPACITOR CERAMIC(HIGH DIELE)	270P 500V K B TS	
		C802P	OCC1500K415	CAPACITOR,CERAMIC(TEMP COMP)	15P 50V J NPO TS	
		C802S	OCK2710W515	CAPACITOR CERAMIC(HIGH DIELE)	270P 500V K B TS	
		C803P	OCQ6821N519	CAPACITOR POLYESTER(MYLAR)	0.0068U 100V K POLY NI TP	
		C803S	OCK2710W515	CAPACITOR CERAMIC(HIGH DIELE)	270P 500V K B TS	
		C804P	181-057Q	C,ELECTROLYTIC	0.0082MF/100V J	
		C804S	OCE1086F630	CAPACITOR,ELECTROLYTIC	1000M SMS 16V M FM5	
		C805P	OCE1076F618	CAPACITOR,ELECTROLYTIC	100M SMS 16V M FM5 TP(5)	
		C805S	OCE1076H618	CAPACITOR,ELECTROLYTIC	100M SMS 25V M FM5 TP(5)	
		C806P	181-131E	C,METAL POLYPROPYLENE	2200PF/2KV J	
		C806S	OCE4761P650	CAPACITOR,ELECTROLYTIC	47M SM 160V M FM7.5	
		C807P	OCE1066K618	CAPACITOR,ELECTROLYTIC	10M SMS 50V M FM5 TP(5)	
		C807S	OCE3361P630	CAPACITOR,ELECTROLYTIC	33M SM 160V M FM5	
		C808P	181-124A	C,ELECTROLYTIC	120MF/400V	

MODEL : CBZ-9825F BPHRO

BUYER NAME : OTTO VERSAND

RUN-DATE : 90.10.23

S	AL	LOCA.NO	PART NO(GS)	DESCRIPTION	SPECIFICATION	REMARKS
		C808S	OCC22202510	CAPACITOR CERAMIC(HIGH DIELE)	2200P 2KV K B S	
		C809P	OCC1020W515	CAPACITOR,CERAMIC(HIGH DIELE)	1000P 500V K B TS	
		C810P	OCC1020W515	CAPACITOR,CERAMIC(HIGH DIELE)	1000P 500V K B TS	
		C811P	OCC1020W515	CAPACITOR,CERAMIC(HIGH DIELE)	1000P 500V K B TS	
		C812P	OCC1020W515	CAPACITOR,CERAMIC(HIGH DIELE)	1000P 500V K B TS	
	△	C814P	181-157A	CAPACITOR	ECK-DNS 222 MEX	
		C815P	OCC1056K618	CAPACITOR,ELECTROLYTIC	1.0M SMS 50V M FL TP(5)	
		C816P	181-410A	CAPACITOR	ECK-DNS472MEX	
		C817P	OCC2710K405	CAPACITOR CERAMIC(TEMP COMP)	270PF 50V 5 SL FM(5MM)	
	△	C851	181-408C	CAPACITOR	0.47MF/250V(ISKRA)	
	△	C852	181-408C	CAPACITOR	0.47MF/250V(ISKRA)	
	△	C853	181-093A	CAPACITOR	CERA DE7090102K 125V	
		C9	OCC4731N409	CAPACITOR POLYESTER(MYLAR)	0.047U 100V J POLY TP	
		C901	OCC3010K400	CAPACITOR CERAMIC(TEMP COMP)	300P 50V J SL S	
		C902	OCC2710K400	CAPACITOR CERAMIC(TEMP COMP)	270P 50V J SL S	
		C903	OCC2710K400	CAPACITOR CERAMIC(TEMP COMP)	270P 50V J SL S	
		C904	OCC4766F618	CAPACITOR,ELECTROLYTIC	47M SMS 16V M FL TP(5)	
		C905	OCC12202510	CAPACITOR,CERAMIC(HIGH DIELE)	1200P 2KV K B S	
		DL201	150-377L	COIL	Y-DELAY(600NS/4.43 TRAP)	
		DL501	175-013A	DELAY LINE	1H SD-11 P1D	
		D1	ODD414809ED	DIODE	(DS4148) TA	
		D2	ODD414809ED	DIODE	(DS4148) TA	
		D201	ODD414809ED	DIODE	(DS4148) TA	
		D204	ODD414809ED	DIODE	(DS4148) TA	
		D205	ODD414809ED	DIODE	(DS4148) TA	
		D206	ODD414809ED	DIODE	(DS4148) TA	
		D207	ODD414809ED	DIODE	(DS4148) TA	
		D208	ODD414809ED	DIODE	(DS4148) TA	
		D210	ODD414809ED	DIODE	(DS4148) TA	
		D3	ODD414809ED	DIODE	(DS4148) TA	
		D301	ODD400309BA	DIODE	IN4003TA	
		D4	ODD414809ED	DIODE	(DS4148) TA	
		D401	ODD400309BA	DIODE	IN4003TA	
		D402	ODD400309BA	DIODE	IN4003TA	
		D403	ODD150009CA	DIODE	RGP15J TA	
		D404	ODD100009BA	DIODE	R10J SYMBOL TP	
		D405	ODD100009BA	DIODE	R10J SYMBOL TP	
		D406	ODD100009AE	DIODE	RU-1A V	
		D407	ODD100009BA	DIODE	R10J SYMBOL TP	
		D408	ODD150009CA	DIODE	RGP15J TA	
		D5	ODD414809ED	DIODE	(DS4148) TA	
		D6	ODD414809ED	DIODE	(DS4148) TA	
		D601	ODD414809ED	DIODE	(DS4148) TA	
		D602	ODD414809ED	DIODE	(DS4148) TA	
		D603	ODD414809ED	DIODE	(DS4148) TA	
		D604	ODD414809ED	DIODE	(DS4148) TA	
		D7	ODD414809ED	DIODE	(DS4148) TA	
		D701	ODD414809ED	DIODE	(DS4148) TA	
		D702	ODD414809ED	DIODE	(DS4148) TA	
		D704	ODD414809ED	DIODE	(DS4148) TA	

MODEL : CBZ-9825F BPHRO

BUYER NAME : OTTO VERSAND

RUN-DATE : 90.10.23

S	AL	LOCA.NO	PART NO(GS)	DESCRIPTION	SPECIFICATION	REMARKS
		D705	ODD414809ED	DIODE	(DS4148) TA	
		D706	ODD414809ED	DIODE	(DS4148) TA	
		D707	ODD414809ED	DIODE	(DS4148) TA	
		D708	ODD414809ED	DIODE	(DS4148) TA	
		D709	ODD414809ED	DIODE	(DS4148) TA	
		D710	ODD414809ED	DIODE	(DS4148) TA	
		D8	ODD414809ED	DIODE	(DS4148) TA	
		D801P	ODD400509AA	DIODE	1N4005 RECT	KEC
		D801S	ODD100009BA	DIODE	R10J SYMBOL TP	
		D802P	ODD400509AA	DIODE	1N4005 RECT	KEC
		D802S	ODD100009BA	DIODE	R10J SYMBOL TP	
		D803P	ODD400509AA	DIODE	1N4005 RECT	KEC
		D803S	ODD300000EJ	DIODE	GU3C	
		D804P	ODD400509AA	DIODE	1N4005 RECT	KEC
		D804S	ODD414809ED	DIODE	(DS4148) TA	
		D805P	ODD100009BA	DIODE	R10J SYMBOL TP	
		D805S	ODD100009BA	DIODE	R10J SYMBOL TP	
		D806P	ODD100009BA	DIODE	R10J SYMBOL TP	
		D807P	ODD100009BA	DIODE	R10J SYMBOL TP	
		D808P	ODD100009BA	DIODE	R10J SYMBOL TP	
		D901	ODD414809ED	DIODE	(DS4148) TA	
		D902	ODD414809ED	DIODE	(DS4148) TA	
		D903	ODD414809ED	DIODE	(DS4148) TA	
△		FR401	ORF0101H600	RESISTOR FUSIBLE	1.0 1/2W 5 A	
△		FR402	ORF0101H600	RESISTOR FUSIBLE	1.0 1/2W 5 A	
△		FR404	180-305G	R,FUSING	1.5 OHM 1W	
△		FR405	ORF0101H600	RESISTOR FUSIBLE	1.0 1/2W 5 A	
△		FR406	ORS1201J665	RESISTOR, FIX METAL FILM OXIDE	1.2K 1W 5 SF20	
△		FR407	ORS1000J665	RESISTOR, FIX METAL FILM OXIDE	100 1W 5 SF20	
△		FR428	180-305H	R,FUSING	1.2K 1/2W	
△		FR612	ORF0102J665	RESISTOR FUSIBLE	10 1W 5 SF20	
△		FR801S	ORF0101H600	RESISTOR FUSIBLE	1.0 1/2W 5 A	
△		FR802S	ORF0101H600	RESISTOR FUSIBLE	1.0 1/2W 5 A	
△		FR803S	ORF0470J765	RESISTOR FUSIBLE	0.47 1W 10 SF20	
△		F851	OFT3151B513	FUSE TIME LAG	3.15A 250V 5.2X20	G SMK
		ICS01	OISG200600A	IC, SGS-THOMSON		
		IC1	OIPH523100A	IC, PHILIPS	SAA 5231	
		IC101	OITF443900A	IC, TELEFUNKEN	TDA4439(TFK)	
		IC2	OIPH524300A	IC, PHILIPS	SAA5243P/E	
		IC201	OISG201400A	IC, SGS-THOMSON	TEA2014	
		IC3	OIGS768815A	IC, GOLDSTAR ELECTRON	GM76C88L-15	
		IC301	OITF117010A	IC, TELEFUNKEN	TDA1170N-A1(TFK)	
		IC4	OIPH846117A	IC, PHILIPS	MAB8461P/W172(SAFARI)	
		IC401	OITF194000A	IC, TELEFUNKEN	TDA1940-A(TFK)	
		IC5	OIMP858200A	IC, MICRO CHIP TECHNOLOGY	PCD8582(MICROCHIPS)	
		IC601	OITF120000A	IC, TELEFUNKEN	TBA120T-A (TFK)	
		IC701	OIPH846400A	IC, PHILIPS	PCF 84C860 (U-COM)	
		IC702	OIMP857200A	IC, MICRO CHIP TECHNOLOGY	PCD8572(MICROCHIPS)	
△		IC801	OISM460100A	IC, SIEMENS	TDA4601	
		J77	ORD1002F609	RESISTOR, FIXED CARBON FILM	10K 1/6W 5 TA52	
		LD701	ODD000000BA	DIODE		

REPLACEMENT PARTS LIST

PAGE : 7

MODEL : CBZ-9825F BPHRO

BUYER NAME : OTTO VERSAND

RUN-DATE : 90.10.23

S	AL	LOCA.NO	PART NO(GS)	DESCRIPTION	SPECIFICATION	REMARKS
		L1	OLA0152K119	INDUCTOR AXIAL LEAD	15UH K 2.3*3.4 TP	
		L101	OLA0152K119	INDUCTOR AXIAL LEAD	15UH K 2.3*3.4 TP	
		L102	150-327Q	AFT COIL	(PC04X)	
		L103	150-327M	VIF COIL	(PC04X)	
		L104	OLA0102K119	INDUCTOR AXIAL LEAD	10UH K 2.3*3.4 TP	
		L105	OLA0152K119	INDUCTOR AXIAL LEAD	15UH K 2.3*3.4 TP	
		L162	150-167D	CHOKO COIL	1.0MH	
		L201	OLA0152K119	INDUCTOR AXIAL LEAD	15UH K 2.3*3.4 TP	
		L401	OLR6801J540	INDUCTOR RADIAL LEAD	6800M J 6X7 F BULK	
		L402	150-224C	COIL	LINEARITY	
		L602	OLA0821K119	INDUCTOR AXIAL LEAD	8.2UH K 2.3*3.4 TP	
		L701	OLA0152K119	INDUCTOR AXIAL LEAD	15UH K 2.3*3.4 TP	
		L801P	OLA0221K119	INDUCTOR AXIAL LEAD	2.2UH K 2.3*3.4 TP	
		L802P	OLA0470K119	INDUCTOR AXIAL LEAD	0.47UH K 2.3*3.4 TP	
		L804S	150-235E	HOR.CHOKE COIL	1MH(1A)	
		L851	150-670B	COIL	LINE FILTER(70MH)	
		PA1	106-047A	PRE-AMP	SBX1620-52(SONY)	
		PC501	OCE1076F618	CAPACITOR,ELECTROLYTIC	100M SMS 16V M FM5 TP(5)	
		PC502	OCK1030K945	CAPACITOR,CERAMIC(HIGH DIELE)	0.01M 50V Z F TS	
		PC503	OCE1056K618	CAPACITOR,ELECTROLYTIC	1.0M SMS 50V M FL TP(5)	
		PC504	OCK1030K945	CAPACITOR,CERAMIC(HIGH DIELE)	0.01M 50V Z F TS	
		PC505	OCC3300K415	CAPACITOR CERAMIC(TEMP COMP)	33P 50V J NPO TP	
		PC506	OCC8200K415	CAPACITOR CERAMIC(TEMP COMP)	82P 50V J NPO TP	
		PC507	OCC1210K415	CAPACITOR,CERAMIC(TEMP COMP)	120PF 50V 5 CH FM(5MM)	
		PC508	OCE4746K618	CAPACITOR,ELECTROLYTIC	0.47M SMS 50V M FL TP(5)	
		PC509	OCE2256K618	CAPACITOR,ELECTROLYTIC	2.2M SMS 50V M FL TP(5)	
		PC510	OCE4746K618	CAPACITOR,ELECTROLYTIC	0.47M SMS 50V M FL TP(5)	
		PC511	OCE4766F618	CAPACITOR,ELECTROLYTIC	47M SMS 16V M FL TP(5)	
		PC512	OCQ1041N509	CAPACITOR POLYESTER(MYLAR)	0.1U 100V K POLY TP	
		PC513	OCE4756K618	CAPACITOR,ELECTROLYTIC	4.7M SMS 50V M FL TP(5)	
		PC514	OCE1046K618	CAPACITOR,ELECTROLYTIC	0.1M SMS 50V M FL TP(5)	
		PC515	OCE1046K618	CAPACITOR,ELECTROLYTIC	0.1M SMS 50V M FL TP(5)	
		PC516	OCE1046K618	CAPACITOR,ELECTROLYTIC	0.1M SMS 50V M FL TP(5)	
		PC517	ORD3301F609	RESISTOR,FIXED CARBON FILM	3.3K 1/6W 5 TA52	
		PC518	OCK1030K945	CAPACITOR,CERAMIC(HIGH DIELE)	0.01M 50V Z F TS	
		PC519	OCQ1541N501	CAPACITOR POLYESTER(MYLAR)	0.15U 100V K POLY F5	
		PC520	OCE2256K618	CAPACITOR,ELECTROLYTIC	2.2M SMS 50V M FL TP(5)	
		PC521	OCQ1041N509	CAPACITOR POLYESTER(MYLAR)	0.1U 100V K POLY TP	
		PC522	OCE4746K618	CAPACITOR,ELECTROLYTIC	0.47M SMS 50V M FL TP(5)	
		PC528	OCE4766F618	CAPACITOR,ELECTROLYTIC	47M SMS 16V M FL TP(5)	
		PD502	ODD414809ED	DIODE	(DS4148) TA	
		PD503	ODD414809ED	DIODE	(DS4148) TA	
		PIC501	OITF356000A	IC, TELEFUNKEN	TDA-3560-B(TFK)	
		PL501	ORD0561G609	RESISTOR,FIXED CARBON FILM	5.6 1/4W 5 TA52	
		PL502	OLA0102K119	INDUCTOR AXIAL LEAD	10UH K 2.3*3.4 TP	
		PL503	OLA0821K119	INDUCTOR AXIAL LEAD	8.2UH K 2.3*3.4 TP	
		PL504	150-163G	MATRIX COIL	ADJ(PC07X)	
		PR501	ORD6803F609	RESISTOR,FIXED CARBON FILM	680K 1/6W 5 TA52	
		PR502	ORD2701F609	RESISTOR,FIXED CARBON FILM	2.7K 1/6W 5 TA52	
		PR503	ORD2200F609	RESISTOR,FIXED CARBON FILM	220 1/6W 5 TA52	

[REPLACEMENT PARTS LIST]

PAGE : 8

MODEL : CBZ-9825F BPHRO

BUYER NAME : OTTO VERSAND

RUN-DATE : 90.10.23

S	AL	LOCA.NO	PART NO(GS)	DESCRIPTION	SPECIFICATION	REMARKS
		PR504	ORD1002F609	RESISTOR, FIXED CARBON FILM	10K 1/6W 5 TA52	
		PR505	ORD2701F609	RESISTOR, FIXED CARBON FILM	2.7K 1/6W 5 TA52	
		PR506	ORD2701F609	RESISTOR, FIXED CARBON FILM	2.7K 1/6W 5 TA52	
		PR507	ORD2701F609	RESISTOR, FIXED CARBON FILM	2.7K 1/6W 5 TA52	
		PR508	ORD1001F609	RESISTOR, FIXED CARBON FILM	1.0K 1/6W 5 TA52	
		PR509	ORD1201F609	RESISTOR, FIXED CARBON FILM	1.2K 1/6W 5 TA52	
		PR510	ORD3900F609	RESISTOR, FIXED CARBON FILM	390 1/6W 5 TA52	
		PR511	ORD4700F609	RESISTOR, FIXED CARBON FILM	470K 1/6W 5 TA52	
		PR512	ORD1001F609	RESISTOR, FIXED CARBON FILM	1.0K 1/6W 5 TA52	
		PR513	ORD5601F609	RESISTOR, FIXED CARBON FILM	5.6K 1/6W 5 TA52	
		PR514	ORD5601F609	RESISTOR, FIXED CARBON FILM	5.6K 1/6W 5 TA52	
		PR515	ORD3901F609	RESISTOR, FIXED CARBON FILM	3.9K 1/6W 5 TA52	
		PR516	ORD1002F609	RESISTOR, FIXED CARBON FILM	10K 1/6W 5 TA52	
		PTC501	181-169A	CAPACITOR	TRIMMER 4.5P-20P	
		PVR501	180-428D	RESISTOR	SEMI VR EVN-D4A A01 B1.0KOHM	
		PVR502	180-428D	RESISTOR	SEMI VR EVN-D4A A01 B1.0KOHM	
		PX501	156-007A	OSCILLATOR	X-TAL 8.86 MHZ	
		Q1	OTR223600AB	TRANSISTOR	KEC KTC2236-0	
		Q161	OTR388009AA	TRANSISTOR	KTC388A(TA)	
		Q162	OTR181509AB	TRANSISTOR	KTC1815-Y TO-92 TP KEC	
		Q201	OTR181509AB	TRANSISTOR	KTC1815-Y TO-92 TP KEC	
		Q202	OTR181509AA	TRANSISTOR	KTC-1815-0(TAPING)	
		Q301	OTR181509AA	TRANSISTOR	KTC-1815-0(TAPING)	
		Q302	OTR181509AA	TRANSISTOR	KTC-1815-0(TAPING)	
		Q401	OTR223000AA	TRANSISTOR	KTC2230A(Y)	
		Q402	OTR155500AA	TRANSISTOR	2SD 1555	
		Q403	OTR181509AC	TRANSISTOR	KTC1815GR TAPING	
		Q701	OTR181509AB	TRANSISTOR	KTC1815-Y TO-92 TP KEC	
		Q702	OTR181509AB	TRANSISTOR	KTC1815-Y TO-92 TP KEC	
		Q703	OTR181509AA	TRANSISTOR	KTC-1815-0(TAPING)	
		Q704	OTR181509AB	TRANSISTOR	KTC1815-Y TO-92 TP KEC	
		Q705	OTR181509AB	TRANSISTOR	KTC1815-Y TO-92 TP KEC	
		Q706	OTR181509AB	TRANSISTOR	KTC1815-Y TO-92 TP KEC	
		Q707	OTR181509AA	TRANSISTOR	KTC-1815-0(TAPING)	
		Q708	OTR181509AA	TRANSISTOR	KTC-1815-0(TAPING)	
		Q709	OTR181509AA	TRANSISTOR	KTC-1815-0(TAPING)	
		Q710	OTR101509AB	TRANSISTOR	KTA1015-0 TP	
		Q711	OTR101509AB	TRANSISTOR	KTA1015-0 TP	
		Q712	OTR101509AB	TRANSISTOR	KTA1015-0 TP	
		Q713	OTR195909AA	TRANSISTOR	C1959 KEC Y TO-92 TP	
		Q714	OTR101509AA	TRANSISTOR	A1015 KEC Y TO-92 TP	
		Q801P	OTR155500AA	TRANSISTOR	2SD 1555	
		Q801S	OTR195909AA	TRANSISTOR	C1959 KEC Y TO-92 TP	
		Q901	OTR206800BA	TRANSISTOR	KTC2068	
		Q902	OTR206800BA	TRANSISTOR	KTC2068	
		Q903	OTR206800BA	TRANSISTOR	KTC2068	
		RL801	141-018A	RELAY	DG12D1-0(M)	
		R1	ORS0182L667	RESISTOR, FIX METAL FILM OXIDE	18 3W 5 SF30	
		R10	ORD3900F609	RESISTOR, FIXED CARBON FILM	390 1/6W 5 TA52	
		R102	ORD1000F609	RESISTOR, FIXED CARBON FILM	100 1/6W 5 TA52	
		R104	ORD5601F609	RESISTOR, FIXED CARBON FILM	5.6K 1/6W 5 TA52	

REPLACEMENT PARTS LIST

PAGE : 9

MODEL : CBZ-9825F BPHRO

BUYER NAME : OTTO VERSAND

RUN-DATE : 90.10.23

S	AL	LOCA.NO	PART NO(GS)	DESCRIPTION	SPECIFICATION	REMARKS
		R105	ORD3301F609	RESISTOR, FIXED CARBON FILM	3.3K 1/6W 5 TA52	
		R106	ORD7500F609	RESISTOR, FIXED CARBON FILM	750 1/6W 5 TA52	
		R107	ORD1001F609	RESISTOR, FIXED CARBON FILM	1.0K 1/6W 5 TA52	
		R108	ORD2702F609	RESISTOR, FIXED CARBON FILM	27K 1/6W 5 TA52	
		R109	ORD2702F609	RESISTOR, FIXED CARBON FILM	27K 1/6W 5 TA52	
		R110	ORD2200F609	RESISTOR, FIXED CARBON FILM	220 1/6W 5 TA52	
		R111	ORD2701F609	RESISTOR, FIXED CARBON FILM	2.7K 1/6W 5 TA52	
		R112	ORD2200F609	RESISTOR, FIXED CARBON FILM	220 1/6W 5 TA52	
		R12	ORD1002F609	RESISTOR, FIXED CARBON FILM	10K 1/6W 5 TA52	
		R13	ORD1004F609	RESISTOR, FIXED CARBON FILM	1.0M 1/6W 5 TA52	
		R14	ORD3900F609	RESISTOR, FIXED CARBON FILM	390 1/6W 5 TA52	
		R15	ORD3900F609	RESISTOR, FIXED CARBON FILM	390 1/6W 5 TA52	
		R16	ORD1201F609	RESISTOR, FIXED CARBON FILM	1.2K 1/6W 5 TA52	
		R161	ORD1002F609	RESISTOR, FIXED CARBON FILM	10K 1/6W 5 TA52	
		R163	ORD4701F609	RESISTOR, FIXED CARBON FILM	4.7K 1/6W 5 TA52	
		R164	ORD6800F609	RESISTOR, FIXED CARBON FILM	680 1/6W 5 TA52	
		R165	ORD0182F609	RESISTOR, FIXED CARBON FILM	18 1/6W 5 TA52	
		R166	ORD4700F609	RESISTOR, FIXED CARBON FILM	470K 1/6W 5 TA52	
		R167	ORD2200F609	RESISTOR, FIXED CARBON FILM	220 1/6W 5 TA52	
		R168	ORD2702F609	RESISTOR, FIXED CARBON FILM	27K 1/6W 5 TA52	
		R169	ORD2702F609	RESISTOR, FIXED CARBON FILM	27K 1/6W 5 TA52	
		R17	ORD1002F609	RESISTOR, FIXED CARBON FILM	10K 1/6W 5 TA52	
		R171	ORD5601F609	RESISTOR, FIXED CARBON FILM	5.6K 1/6W 5 TA52	
		R173	ORD4704F609	RESISTOR, FIXED CARBON FILM	4.7M 1/6W 5 TA52	
		R175	ORD4704F609	RESISTOR, FIXED CARBON FILM	4.7M 1/6W 5 TA52	
		R18	ORD4701F609	RESISTOR, FIXED CARBON FILM	4.7K 1/6W 5 TA52	
		R19	ORD3900F609	RESISTOR, FIXED CARBON FILM	390 1/6W 5 TA52	
		R2	ORD8200G609	RESISTOR, FIXED CARBON FILM	820 1/4W 5 TA52	
		R20	ORD3900F609	RESISTOR, FIXED CARBON FILM	390 1/6W 5 TA52	
		R201	ORD1201F609	RESISTOR, FIXED CARBON FILM	1.2K 1/6W 5 TA52	
		R202	ORD4701F609	RESISTOR, FIXED CARBON FILM	4.7K 1/6W 5 TA52	
		R203	ORD1200F609	RESISTOR, FIXED CARBON FILM	120 1/6W 5 TA52	
		R205	ORD5601F609	RESISTOR, FIXED CARBON FILM	5.6K 1/6W 5 TA52	
		R207	ORD1002F609	RESISTOR, FIXED CARBON FILM	10K 1/6W 5 TA52	
		R209	ORD2202F609	RESISTOR, FIXED CARBON FILM	22K 1/6W 5 TA52	
		R21	ORD1001F609	RESISTOR, FIXED CARBON FILM	1.0K 1/6W 5 TA52	
		R210	ORD1002F609	RESISTOR, FIXED CARBON FILM	10K 1/6W 5 TA52	
		R211	ORD1002F609	RESISTOR, FIXED CARBON FILM	10K 1/6W 5 TA52	
		R212	ORD1501F609	RESISTOR, FIXED CARBON FILM	1.5K 1/6W 5 TA52	
		R214	ORD1001F609	RESISTOR, FIXED CARBON FILM	1.0K 1/6W 5 TA52	
		R215	ORD5600F609	RESISTOR, FIXED CARBON FILM	560 1/6W 5 TA52	
		R218	ORD3300F609	RESISTOR, FIXED CARBON FILM	330 1/6W 5 TA52	
		R219	ORD4701F609	RESISTOR, FIXED CARBON FILM	4.7K 1/6W 5 TA52	
		R22	ORD6801F609	RESISTOR, FIXED CARBON FILM	6.8K 1/6W 5 TA52	
		R220	ORD1800F609	RESISTOR, FIXED CARBON FILM	180 1/6W 5 TA52	
		R221	ORD1800F609	RESISTOR, FIXED CARBON FILM	180 1/6W 5 TA52	
		R222	ORD1800F609	RESISTOR, FIXED CARBON FILM	180 1/6W 5 TA52	
		R225	ORD0752F609	RESISTOR, FIXED CARBON FILM	75 1/6W 5% TA	
		R226	ORD2202F609	RESISTOR, FIXED CARBON FILM	22K 1/6W 5 TA52	
		R227	ORD2202F609	RESISTOR, FIXED CARBON FILM	22K 1/6W 5 TA52	

REPLACEMENT PARTS LIST

PAGE : 10

MODEL : CBZ-9825F BPHRO

BUYER NAME : OTTO VERSAND

RUN-DATE : 90.10.23

S	AL	LOCA.NO	PART NO(GS)	DESCRIPTION	SPECIFICATION	REMARKS
		R228	ORD4702F609	RESISTOR, FIXED CARBON FILM	47K 1/6W 5 TA52	
		R229	ORD1002F609	RESISTOR, FIXED CARBON FILM	10K 1/6W 5 TA52	
		R23	ORD3301F609	RESISTOR, FIXED CARBON FILM	3.3K 1/6W 5 TA52	
		R230	ORD1502F609	RESISTOR, FIXED CARBON FILM	15K 1/6W 5 TA52	
		R3	ORD5602F609	RESISTOR, FIXED CARBON FILM	56K 1/6W 5 TA52	
		R301	ORN4702F609	RESISTOR FIX METAL FILM	47K 1/6W 5 TA52	
		R302	ORD5602F609	RESISTOR, FIXED CARBON FILM	56K 1/6W 5 TA52	
		R303	ORD1502F609	RESISTOR, FIXED CARBON FILM	15K 1/6W 5 TA52	
		R304	ORD4700H609	RESISTOR, FIXED CARBON FILM	470 1/2W 5 TA52	
		R305	ORN8201F609	RESISTOR FIX METAL FILM	8.2K 1/6W 5 TA52	
		R306	ORD1002F609	RESISTOR, FIXED CARBON FILM	10K 1/6W 5 TA52	
		R307	ORD2201G609	RESISTOR, FIXED CARBON FILM	2.2K 1/4W 5 TA52	
		R308	ORN0121H609	RESISTOR FIX METAL FILM	1.2 1/2W 5 TA52	
		R309	ORD1201H609	RESISTOR, FIXED CARBON FILM	1.2K 1/2W 5 TA52	
		R310	ORD2403F609	RESISTOR, FIXED CARBON FILM	240K 1/6W 5 TA52	
		R311	ORD9102F609	RESISTOR, FIXED CARBON FILM	91K 1/6W 5 TA52	
		R312	ORD2701F609	RESISTOR, FIXED CARBON FILM	2.7K 1/6W 5 TA52	
		R313	ORD2203F609	RESISTOR, FIXED CARBON FILM	220K 1/6W 5 TA52	
		R314	ORD6803F609	RESISTOR, FIXED CARBON FILM	680K 1/6W 5 TA52	
		R315	ORD3902F609	RESISTOR, FIXED CARBON FILM	39K 1/6W 5 TA52	
		R316	ORD5601F609	RESISTOR, FIXED CARBON FILM	5.6K 1/6W 5 TA52	
		R318	ORD1002F609	RESISTOR, FIXED CARBON FILM	10K 1/6W 5 TA52	
		R319	ORD2202F609	RESISTOR, FIXED CARBON FILM	22K 1/6W 5 TA52	
		R320	ORS0102J665	RESISTOR, FIX METAL FILM OXIDE	10 1W 5 SF20	
		R4	ORD3300F609	RESISTOR, FIXED CARBON FILM	330 1/6W 5 TA52	
		R401	ORD5600G609	RESISTOR, FIXED CARBON FILM	560 1/4W 5 TA52	
		R402	ORD5600F609	RESISTOR, FIXED CARBON FILM	560 1/6W 5 TA52	
		R403	ORD1201F609	RESISTOR, FIXED CARBON FILM	1.2K 1/6W 5 TA52	
		R404	ORD0682G609	RESISTOR, FIXED CARBON FILM	68 1/4W 5 TA52	
		R405	ORD6800F609	RESISTOR, FIXED CARBON FILM	680 1/6W 5 TA52	
		R406	ORS1000J665	RESISTOR, FIX METAL FILM OXIDE	100 1W 5 SF20	
		R409	ORD2203F609	RESISTOR, FIXED CARBON FILM	220K 1/6W 5 TA52	
		R410	ORD3301F609	RESISTOR, FIXED CARBON FILM	3.3K 1/6W 5 TA52	
		R411	ORD4701F609	RESISTOR, FIXED CARBON FILM	4.7K 1/6W 5 TA52	
		R412	ORD3301F609	RESISTOR, FIXED CARBON FILM	3.3K 1/6W 5 TA52	
		R413	ORD4702F609	RESISTOR, FIXED CARBON FILM	47K 1/6W 5 TA52	
		R414	ORD4702F609	RESISTOR, FIXED CARBON FILM	47K 1/6W 5 TA52	
		R415	ORD1000F609	RESISTOR, FIXED CARBON FILM	100 1/6W 5 TA52	
		R416	ORD1001F609	RESISTOR, FIXED CARBON FILM	1.0K 1/6W 5 TA52	
		R419	ORD3901F609	RESISTOR, FIXED CARBON FILM	3.9K 1/6W 5 TA52	
		R420	ORD1003F609	RESISTOR, FIXED CARBON FILM	100K 1/6W 5 TA52	
		R421	ORD1203F609	RESISTOR, FIXED CARBON FILM	120K 1/6W 5 TA52	
		R422	ORN1202F609	RESISTOR FIX METAL FILM	12K 1/6W 5 TA52	
		R423	ORD8202F609	RESISTOR, FIXED CARBON FILM	82K 1/6W 5 TA52	
		R424	ORD1504F609	RESISTOR, FIXED CARBON FILM	1.5M 1/6W 5 TA52	
		R425	ORD3302F609	RESISTOR, FIXED CARBON FILM	33K 1/6W 5% TA	
		R426	ORD1001F609	RESISTOR, FIXED CARBON FILM	1.0K 1/6W 5 TA52	
		R427	ORN0121J665	RESISTOR FIX METAL FILM	1.2 1W 5 SF20	
		R429	ORD7502F609	RESISTOR, FIXED CARBON FILM	75K 1/6W 5 TA52	
		R430	ORD6802F609	RESISTOR, FIXED CARBON FILM	68K 1/6W 5 TA52	

MODEL : CBZ-9825F BPHRO

BUYER NAME : OTTO VERSAND

RUN-DATE : 90.10.23

S	AL	LOCA.NO	PART NO(GS)	DESCRIPTION	SPECIFICATION	REMARKS
		R432	ORD6801F609	RESISTOR, FIXED CARBON FILM	6.8K 1/6W 5 TA52	
		R433	ORD1202F609	RESISTOR, FIXED CARBON FILM	12K 1/6W 5 TA52	
		R434	ORD5601F609	RESISTOR, FIXED CARBON FILM	5.6K 1/6W 5 TA52	
		R435	ORD8202F609	RESISTOR, FIXED CARBON FILM	82K 1/6W 5 TA52	
		R436	ORD1501F609	RESISTOR, FIXED CARBON FILM	1.5K 1/6W 5 TA52	
		R437	ORN0151J665	RESISTOR FIX METAL FILM	1.5 1W 5 SF20	
		R438	ORD8202F609	RESISTOR, FIXED CARBON FILM	82K 1/6W 5 TA52	
		R5	ORD2202F609	RESISTOR, FIXED CARBON FILM	22K 1/6W 5 TA52	
		R6	ORD4700F609	RESISTOR, FIXED CARBON FILM	470K 1/6W 5 TA52	
		R601	ORD0102F609	RESISTOR, FIXED CARBON FILM	10 1/6W 5 TA52	
		R602	ORD7501F609	RESISTOR, FIXED CARBON FILM	7.5K 1/6W 5 TA52	
		R603	ORD6800F609	RESISTOR, FIXED CARBON FILM	680 1/6W 5 TA52	
		R604	ORD3902F609	RESISTOR, FIXED CARBON FILM	39K 1/6W 5 TA52	
		R605	ORD8201F609	RESISTOR, FIXED CARBON FILM	8.2K 1/6W 5 TA52	
		R606	ORD1003F609	RESISTOR, FIXED CARBON FILM	100K 1/6W 5 TA52	
		R607	ORD1003F609	RESISTOR, FIXED CARBON FILM	100K 1/6W 5 TA52	
		R608	ORD1001F609	RESISTOR, FIXED CARBON FILM	1.0K 1/6W 5 TA52	
		R609	ORD5602F609	RESISTOR, FIXED CARBON FILM	56K 1/6W 5 TA52	
		R610	ORD0101F609	RESISTOR, FIXED CARBON FILM	1.0 1/6W 5 TA52	
		R611	ORD9102F609	RESISTOR, FIXED CARBON FILM	91K 1/6W 5 TA52	
		R618	ORD1002F609	RESISTOR, FIXED CARBON FILM	10K 1/6W 5 TA52	
		R623	ORD1501G609	RESISTOR, FIXED CARBON FILM	1.5K 1/4W 5 TA52	
		R7	ORD4700F609	RESISTOR, FIXED CARBON FILM	470K 1/6W 5 TA52	
		R701	ORD5601F609	RESISTOR, FIXED CARBON FILM	5.6K 1/6W 5 TA52	
		R702	ORD5601F609	RESISTOR, FIXED CARBON FILM	5.6K 1/6W 5 TA52	
		R703	ORD5601F609	RESISTOR, FIXED CARBON FILM	5.6K 1/6W 5 TA52	
		R704	ORD5601F609	RESISTOR, FIXED CARBON FILM	5.6K 1/6W 5 TA52	
		R705	ORD5601F609	RESISTOR, FIXED CARBON FILM	5.6K 1/6W 5 TA52	
		R706	ORD5601F609	RESISTOR, FIXED CARBON FILM	5.6K 1/6W 5 TA52	
		R707	ORD3302F609	RESISTOR, FIXED CARBON FILM	33K 1/6W 5% TA	
		R708	ORD3302F609	RESISTOR, FIXED CARBON FILM	33K 1/6W 5% TA	
		R709	ORD3302F609	RESISTOR, FIXED CARBON FILM	33K 1/6W 5% TA	
		R710	ORD5602F609	RESISTOR, FIXED CARBON FILM	56K 1/6W 5 TA52	
		R711	ORD5602F609	RESISTOR, FIXED CARBON FILM	56K 1/6W 5 TA52	
		R712	ORD5602F609	RESISTOR, FIXED CARBON FILM	56K 1/6W 5 TA52	
		R713	ORD1502F609	RESISTOR, FIXED CARBON FILM	15K 1/6W 5 TA52	
		R714	ORD1003F609	RESISTOR, FIXED CARBON FILM	100K 1/6W 5 TA52	
		R715	ORD1201F609	RESISTOR, FIXED CARBON FILM	1.2K 1/6W 5 TA52	
		R716	ORD5601F609	RESISTOR, FIXED CARBON FILM	5.6K 1/6W 5 TA52	
		R717	ORD6801F609	RESISTOR, FIXED CARBON FILM	6.8K 1/6W 5 TA52	
		R718	ORD2201F609	RESISTOR, FIXED CARBON FILM	2.2K 1/6W 5 TA52	
		R719	ORD1001F609	RESISTOR, FIXED CARBON FILM	1.0K 1/6W 5 TA52	
		R720	ORD1000F609	RESISTOR, FIXED CARBON FILM	100 1/6W 5 TA52	
		R721	ORD1000F609	RESISTOR, FIXED CARBON FILM	100 1/6W 5 TA52	
		R722	ORD1002F609	RESISTOR, FIXED CARBON FILM	10K 1/6W 5 TA52	
		R723	ORD6802F609	RESISTOR, FIXED CARBON FILM	68K 1/6W 5 TA52	
		R724	ORD2201F609	RESISTOR, FIXED CARBON FILM	2.2K 1/6W 5 TA52	
		R725	ORD1201F609	RESISTOR, FIXED CARBON FILM	1.2K 1/6W 5 TA52	
		R726	ORD1003F609	RESISTOR, FIXED CARBON FILM	100K 1/6W 5 TA52	
		R727	ORD1800F609	RESISTOR, FIXED CARBON FILM	180 1/6W 5 TA52	

[REPLACEMENT PARTS LIST]

PAGE : 12

MODEL : CBZ-9825F BPHRO

BUYER NAME : OTTO VERSAND

RUN-DATE : 90.10.23

S	AL	LOCA.NO	PART NO(GS)	DESCRIPTION	SPECIFICATION	REMARKS
		R728	ORD1001F609	RESISTOR, FIXED CARBON FILM	1.0K 1/6W 5 TA52	
		R729	ORD8201F609	RESISTOR, FIXED CARBON FILM	8.2K 1/6W 5 TA52	
		R730	ORD1502F609	RESISTOR, FIXED CARBON FILM	15K 1/6W 5 TA52	
		R731	ORD1003F609	RESISTOR, FIXED CARBON FILM	100K 1/6W 5 TA52	
		R732	ORD1002F609	RESISTOR, FIXED CARBON FILM	10K 1/6W 5 TA52	
		R733	ORD2701F609	RESISTOR, FIXED CARBON FILM	2.7K 1/6W 5 TA52	
		R734	ORD1002F609	RESISTOR, FIXED CARBON FILM	10K 1/6W 5 TA52	
		R735	ORD1002F609	RESISTOR, FIXED CARBON FILM	10K 1/6W 5 TA52	
		R736	ORD1002F609	RESISTOR, FIXED CARBON FILM	10K 1/6W 5 TA52	
		R737	ORD6801F609	RESISTOR, FIXED CARBON FILM	6.8K 1/6W 5 TA52	
		R738	ORD1201F609	RESISTOR, FIXED CARBON FILM	1.2K 1/6W 5 TA52	
		R739	ORD1001F609	RESISTOR, FIXED CARBON FILM	1.0K 1/6W 5 TA52	
		R740	ORD2200F609	RESISTOR, FIXED CARBON FILM	220 1/6W 5 TA52	
		R741	ORD6202F609	RESISTOR, FIXED CARBON FILM	62K 1/6W 5 TA52	
		R742	ORD3001F609	RESISTOR, FIXED CARBON FILM	3.0K 1/6W 5 TA52	
		R743	ORD1501F609	RESISTOR, FIXED CARBON FILM	1.5K 1/6W 5 TA52	
		R744	ORD1201F609	RESISTOR, FIXED CARBON FILM	1.2K 1/6W 5 TA52	
		R745	ORD1001F609	RESISTOR, FIXED CARBON FILM	1.0K 1/6W 5 TA52	
		R746	ORD1802F609	RESISTOR, FIXED CARBON FILM	18K 1/6W 5 TA52	
		R747	ORD2701F609	RESISTOR, FIXED CARBON FILM	2.7K 1/6W 5 TA52	
		R748	ORD7501F609	RESISTOR, FIXED CARBON FILM	7.5K 1/6W 5 TA52	
		R749	ORD1001F609	RESISTOR, FIXED CARBON FILM	1.0K 1/6W 5 TA52	
		R750	ORD3302F609	RESISTOR, FIXED CARBON FILM	33K 1/6W 5% TA	
		R751	ORD3302F609	RESISTOR, FIXED CARBON FILM	33K 1/6W 5% TA	
		R752	ORD1502F609	RESISTOR, FIXED CARBON FILM	15K 1/6W 5 TA52	
		R753	ORD2201F609	RESISTOR, FIXED CARBON FILM	2.2K 1/6W 5 TA52	
		R754	ORD1202F609	RESISTOR, FIXED CARBON FILM	12K 1/6W 5 TA52	
		R755	ORD1002F609	RESISTOR, FIXED CARBON FILM	10K 1/6W 5 TA52	
		R756	ORD4701F609	RESISTOR, FIXED CARBON FILM	4.7K 1/6W 5 TA52	
		R757	ORD1801F609	RESISTOR, FIXED CARBON FILM	1.8K 1/6W 5 TA52	
		R758	ORD1002F609	RESISTOR, FIXED CARBON FILM	10K 1/6W 5 TA52	
		R759	ORD1800G609	RESISTOR, FIXED CARBON FILM	180 1/4W 5 TA52	
		R760	ORD8200G609	RESISTOR, FIXED CARBON FILM	820 1/4W 5 TA52	
		R761	ORD2701G609	RESISTOR, FIXED CARBON FILM	2.7K 1/4W 5 TA52	
		R762	ORD4702F609	RESISTOR, FIXED CARBON FILM	47K 1/6W 5 TA52	
		R763	ORD6800F609	RESISTOR, FIXED CARBON FILM	680 1/6W 5 TA52	
		R764	ORD6800F609	RESISTOR, FIXED CARBON FILM	680 1/6W 5 TA52	
		R765	ORD6800F609	RESISTOR, FIXED CARBON FILM	680 1/6W 5 TA52	
		R766	ORD3300F609	RESISTOR, FIXED CARBON FILM	330 1/6W 5 TA52	
		R767	ORD2702F609	RESISTOR, FIXED CARBON FILM	27K 1/6W 5 TA52	
		R768	ORD2200G609	RESISTOR, FIXED CARBON FILM	2.2K 1/4W 5 TA52	
		R770	ORD1501F609	RESISTOR, FIXED CARBON FILM	1.5K 1/6W 5 TA52	
		R8	ORD4700F609	RESISTOR, FIXED CARBON FILM	470K 1/6W 5 TA52	
		R801P	ORD2200F609	RESISTOR, FIXED CARBON FILM	220 1/6W 5 TA52	
		R802P	ORD1201F609	RESISTOR, FIXED CARBON FILM	1.2K 1/6W 5 TA52	
		R802S	ORD1002F609	RESISTOR, FIXED CARBON FILM	10K 1/6W 5 TA52	
		R803P	ORD1002F609	RESISTOR, FIXED CARBON FILM	10K 1/6W 5 TA52	
		R804P	ORD1602F609	RESISTOR, FIXED CARBON FILM	16K 1/6W 5 TA52	
		R804S	ORD3901F609	RESISTOR, FIXED CARBON FILM	3.9K 1/6W 5 TA52	
		R805P	ORS2403J665	RESISTOR, FIX METAL FILM OXIDE	240K 1W 5 SF20	

REPLACEMENT PARTS LIST

MODEL : CBZ-9825F BPHRO

BUYER NAME : OTTO VERSAND

RUN-DATE : 90.10.23

S	AL	LOCA.NO	PART NO(GS)	DESCRIPTION	SPECIFICATION	REMARKS
		R806P	ORS2403J665	RESISTOR, FIX METAL FILM OXIDE	240K 1W 5 SF20	
		R807P	ORS0822J665	RESISTOR, FIX METAL FILM OXIDE	82 1W 5 SF20	
		R808P	ORN0680G609	RESISTOR FIX METAL FILM	0.68 1/4W 5 TA52	
		R809P	180-142E	RESISTOR CEMENT RWR	180 OHM 5W	
		R810P	ORD0682G609	RESISTOR, FIXED CARBON FILM	68 1/4W 5 TA52	
		R811P	ORS1502L667	RESISTOR, FIX METAL FILM OXIDE	15K 3W 5 SF30	
		R811S	ORS1500K600	RESISTOR, FIX METAL FILM OXIDE	150 2W 5 A	
	△	R812P	180-142F	R. CEMENT RWR	2.2-J 5W	
		R813P	180-042B	RESISTOR COMP GF	4.7 OHM 1/2W	
		R814P	ORD1003F609	RESISTOR, FIXED CARBON FILM	100K 1/6W 5 TA52	
		R815P	ORD3002G609	RESISTOR, FIXED CARBON FILM	30K 1/4W 5 TA52	
		R816P	ORD3002G609	RESISTOR, FIXED CARBON FILM	30K 1/4W 5 TA52	
		R817P	ORD0182G609	RESISTOR, FIXED CARBON FILM	18 1/4W 5 TA52	
		R9	ORD1001F609	RESISTOR, FIXED CARBON FILM	1.0K 1/6W 5 TA52	
		R901	ORD1000G609	RESISTOR, FIXED CARBON FILM	100 1/4W 5 TA52	
		R902	ORD1000G609	RESISTOR, FIXED CARBON FILM	100 1/4W 5 TA52	
		R903	ORD1000G609	RESISTOR, FIXED CARBON FILM	100 1/4W 5 TA52	
		R904	ORS1002J665	RESISTOR, FIX METAL FILM OXIDE	10K 1W 5 SF20	
		R905	ORS1002J665	RESISTOR, FIX METAL FILM OXIDE	10K 1W 5 SF20	
		R906	ORS1002J665	RESISTOR, FIX METAL FILM OXIDE	10K 1W 5 SF20	
		R907	ORD2701H609	RESISTOR, FIXED CARBON FILM	2.7K 1/2W 5 TA52	
		R908	ORD2701H609	RESISTOR, FIXED CARBON FILM	2.7K 1/2W 5 TA52	
		R909	ORD2701H609	RESISTOR, FIXED CARBON FILM	2.7K 1/2W 5 TA52	
		R910	ORD1801G609	RESISTOR, FIXED CARBON FILM	1.8K 1/4W 5 M10	
		R911	ORD1801G609	RESISTOR, FIXED CARBON FILM	1.8K 1/4W 5 M10	
		R912	ORD1801G609	RESISTOR, FIXED CARBON FILM	1.8K 1/4W 5 M10	
		R913	ORD3900G609	RESISTOR, FIXED CARBON FILM	390 1/4W 5 TA52	
		R914	ORD3900G609	RESISTOR, FIXED CARBON FILM	390 1/4W 5 TA52	
		R915	ORD3900G609	RESISTOR, FIXED CARBON FILM	390 1/4W 5 TA52	
		R916	ORD1800G609	RESISTOR, FIXED CARBON FILM	180 1/4W 5 TA52	
		R917	ORD1000G609	RESISTOR, FIXED CARBON FILM	100 1/4W 5 TA52	
		R921	ORD1000G609	RESISTOR, FIXED CARBON FILM	100 1/4W 5 TA52	
		R922	ORD1000G609	RESISTOR, FIXED CARBON FILM	100 1/4W 5 TA52	
		R923	ORD1000G609	RESISTOR, FIXED CARBON FILM	100 1/4W 5 TA52	
		SC501	OCE4756K618	CAPACITOR, ELECTROLYTIC	4.7M SMS 50V M FL	TP(5)
		SC502	OCK1030K945	CAPACITOR, CERAMIC(HIGH DIELE)	0.01M 50V Z F	TS
		SC503	OCC1031N509	CAPACITOR POLYESTER(MYLAR)	0.01U 100V K POLY	TP
		SC504	OCC3000K415	CAPACITOR CERAMIC(TEMP COMP)	30P 50V J NPO	TP
		SC505	OCE1066F618	CAPACITOR, ELECTROLYTIC	10M SMS 16V M FM5	TP(5)
		SC506	OCK1030K945	CAPACITOR, CERAMIC(HIGH DIELE)	0.01M 50V Z F	TS
		SC507	OCC1010K405	CAPACITOR, CERAMIC(TEMP COMP)	100P 50V J SL	TS
		SC508	OCE2256K618	CAPACITOR, ELECTROLYTIC	2.2M SMS 50V M FL	TP(5)
		SC509	OCK1030K945	CAPACITOR, CERAMIC(HIGH DIELE)	0.01M 50V Z F	TS
		SC510	OCK1030K945	CAPACITOR, CERAMIC(HIGH DIELE)	0.01M 50V Z F	TS
		SC511	OCC5610K405	CAPACITOR CERAMIC(TEMP COMP)	560P 50V J SL	TS
		SC512	OCK1030K945	CAPACITOR, CERAMIC(HIGH DIELE)	0.01M 50V Z F	TS
		SC514	OCK1030K945	CAPACITOR, CERAMIC(HIGH DIELE)	0.01M 50V Z F	TS
		SC515	OCK1030K945	CAPACITOR, CERAMIC(HIGH DIELE)	0.01M 50V Z F	TS
		SC516	OCE4766F618	CAPACITOR, ELECTROLYTIC	47M SMS 16V M FL	TP(5)
		SC517	OCK1030K945	CAPACITOR, CERAMIC(HIGH DIELE)	0.01M 50V Z F	TS

REPLACEMENT PARTS LIST

PAGE : 14

MODEL : CBZ-9825F BPHRO

BUYER NAME : OTTO VERSAND

RUN-DATE : 90.10.23

S	AL	LOCA.NO	PART NO(GS)	DESCRIPTION	SPECIFICATION	REMARKS
		SC518	OCC2710K405	CAPACITOR CERAMIC(TEMP COMP)	270PF 50V 5 SL FM(5MM)	
		SC519	OCC3010K400	CAPACITOR CERAMIC(TEMP COMP)	300P 50V J SL S	
		SC520	OCC1030K945	CAPACITOR,CERAMIC(HIGH DIELE)	0.01M 50V Z F TS	
		SC521	OCE1056K618	CAPACITOR,ELECTROLYTIC	1.0M SMS 50V M FL TP(5)	
		SC523	OCC3010K400	CAPACITOR CERAMIC(TEMP COMP)	300P 50V J SL S	
		SC524	OCQ1041N509	CAPACITOR POLYESTER(MYLAR)	0.1U 100V K POLY TP	
		SC525	OCQ1041N509	CAPACITOR POLYESTER(MYLAR)	0.1U 100V K POLY TP	
		SC526	OCC1030K945	CAPACITOR,CERAMIC(HIGH DIELE)	0.01M 50V Z F TS	
		SC529	OCE1056K618	CAPACITOR,ELECTROLYTIC	1.0M SMS 50V M FL TP(5)	
		SIC501	OIMA563300A	IC, MATSUSHITA	AN5633K(MAT.)	
		SL501	150-489B	COIL	SECAM BELL FILTER	
		SL503	OLA0102K119	INDUCTOR AXIAL LEAD	10UH K 2.3*3.4 TP	
		SL504	OLA0152K119	INDUCTOR AXIAL LEAD	15UH K 2.3*3.4 TP	
		SL506	150-489D	COIL	SECAM DEM.	
		SR501	ORD2201F609	RESISTOR,FIXED CARBON FILM	2.2K 1/6W 5 TA52	
		SR502	ORD5600G609	RESISTOR,FIXED CARBON FILM	560 1/4W 5 TA52	
		SR503	ORD8202F609	RESISTOR,FIXED CARBON FILM	82K 1/6W 5 TA52	
		SR504	ORD4700F609	RESISTOR,FIXED CARBON FILM	470K 1/6W 5 TA52	
		SR505	ORD5602F609	RESISTOR,FIXED CARBON FILM	56K 1/6W 5 TA52	
		SR506	ORD2702F609	RESISTOR,FIXED CARBON FILM	27K 1/6W 5 TA52	
		SR507	ORD3302F609	RESISTOR,FIXED CARBON FILM	33K 1/6W 5% TA	
		SR508	ORD2201F609	RESISTOR,FIXED CARBON FILM	2.2K 1/6W 5 TA52	
		SR509	ORD2200F609	RESISTOR,FIXED CARBON FILM	220 1/6W 5 TA52	
		SR510	ORD2201F609	RESISTOR,FIXED CARBON FILM	2.2K 1/6W 5 TA52	
		SVR501	180-428C	RESISTOR	SEMI VR EVN-D4A A01 B500 OHM	
		SW301	140-111A	SWITCH	SVC P12T21	
△		SW851	140-278C	SWITCH	MAIN,ME5C(TV-5)	
		TC1	181-169A	CAPACITOR	TRIMMER 4.5P-20P	
△		TH851	163-012A	THERMISTOR	PTH451A02BG180M290	
		T1	166-266A	FILTER	PIEZONATOR,EFC-A40R40M1	
		T401	151-116B	TRANSFORMER	H.DRIVE(PC04X)	
△		T402	154*177J	FBT	PAL 19INCH	
△		T801	151-346B	TRANSFORMER	SMPS,PC04A	
		VR101	180-428G	RESISTOR	SEMI VR EVN-D4A A01 B5.0KOHM	
		VR301	180-428L	RESISTOR	SEMI VR EVN-D4A A01 B100KOHM	
		VR302	180-428L	RESISTOR	SEMI VR EVN-D4A A01 B100KOHM	
		VR303	ORV1503D230	VARIABLE RESISTOR,CARBON FILM	50K 6 ST P3 L2.5 5	
		VR401	180-428H	RESISTOR	SEMI VR EVN-D4A A01 B10K OHM	
		VR402	180-428H	RESISTOR	SEMI VR EVN-D4A A01 B10K OHM	
		VR701	180-428E	RESISTOR	SEMI VR EVN-D4A A01 B2.0KOHM	
		VR801	180-428G	RESISTOR	SEMI VR EVN-D4A A01 B5.0KOHM	
		VR901	180-428G	RESISTOR	SEMI VR EVN-D4A A01 B5.0KOHM	
		VR902	180-428G	RESISTOR	SEMI VR EVN-D4A A01 B5.0KOHM	
		VR903	180-428G	RESISTOR	SEMI VR EVN-D4A A01 B5.0KOHM	
		VR904	180-428C	RESISTOR	SEMI VR EVN-D4A A01 B500 OHM	
		VR905	180-428C	RESISTOR	SEMI VR EVN-D4A A01 B500 OHM	
		XX3	156-007C	OSCILLATOR	OSC.X-TAL 6.0MHZ	
		X1	156-007D	OSCILLATOR	OSC.X-TAL 13.875MHZ	
		X2	156-007C	OSCILLATOR	OSC.X-TAL 6.0MHZ	
		X701	156-007L	OSCILLATOR	X-TAL 10.000MHZ	

REPLACEMENT PARTS LIST

PAGE : 15

MODEL : CBZ-9825F BPHRO

BUYER NAME : OTTO VERSAND

RUN-DATE : 90.10.23

S	AL	LOCA.NO	PART NO(GS)	DESCRIPTION	SPECIFICATION	REMARKS	
		ZD1	0DZ560009AA	DIODE ZENER	Z5.6BM TA		
		ZD401	0DZ330000AB	DIODE ZENER	HZ 33TE (BULK)		
		ZD402	0DZ750009AA	DIODE ZENER	Z7.5BM TA		
		ZD701	0DZ560009AA	DIODE ZENER	Z5.6BM TA		
		ZF101	166-250A	FILTER	SAW FILTER G1872		
		Z101	166-031B	FILTER	TRAP,CERAMIC TPS 5.5MB		
		Z102	166-031E	FILTER	TRAP,CERAMIC 6.5 MB		
		Z601	166-126B	FILTER	CDA 5.5MC24B		
		Z602	166-002D	FILTER	CERAMIC SFE 5.5MB		
			*** END OF DATA ***				

MEMO

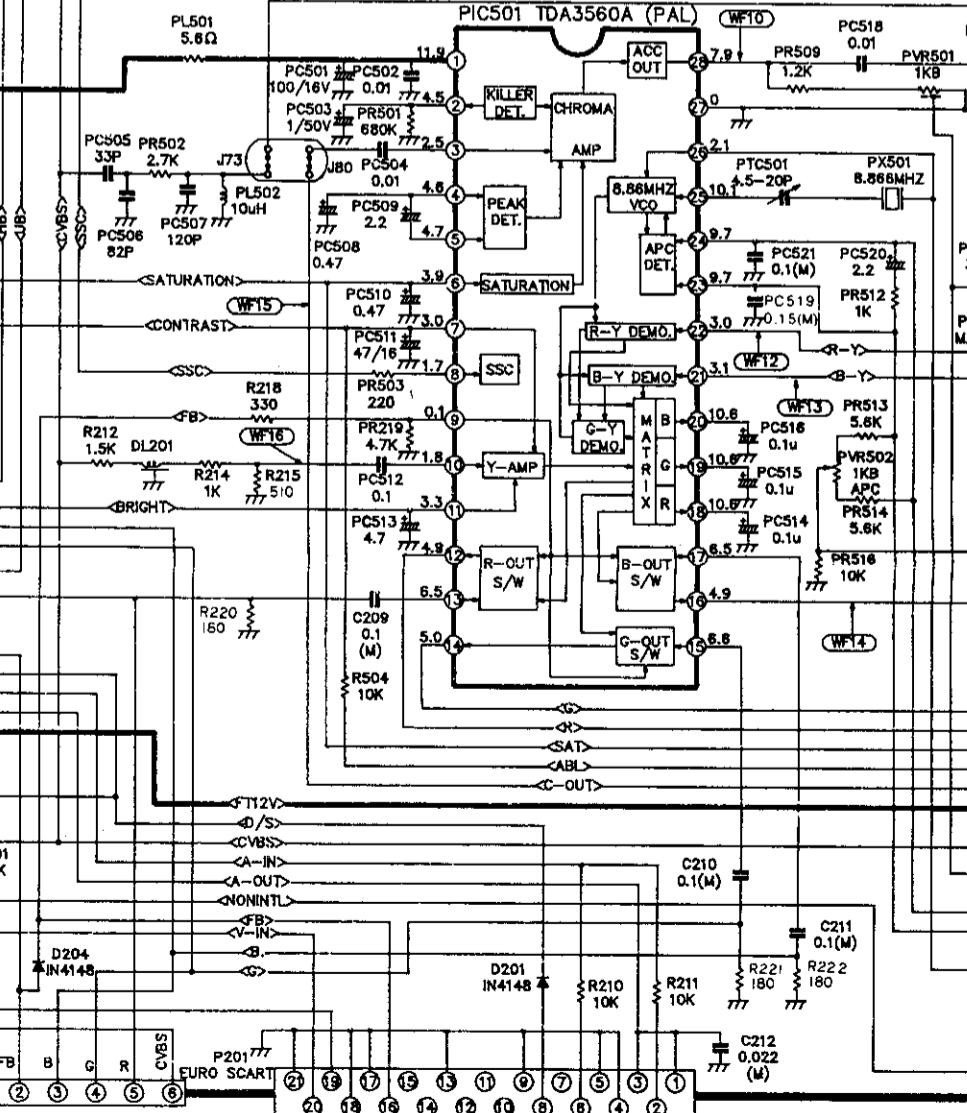
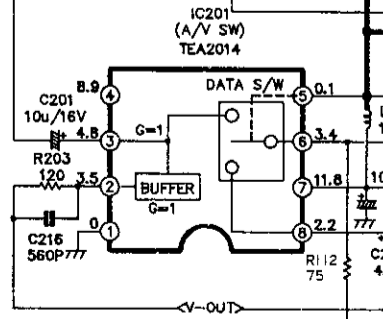
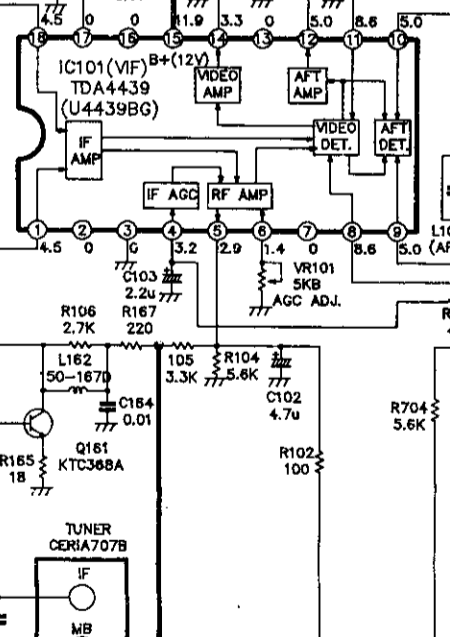
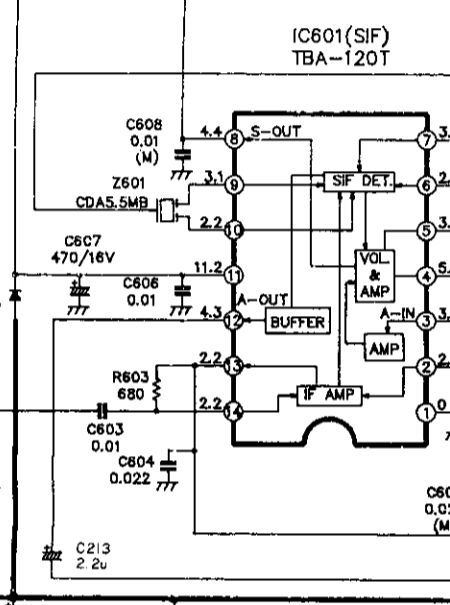
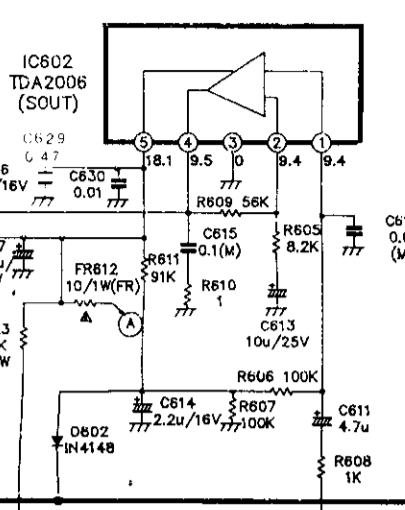
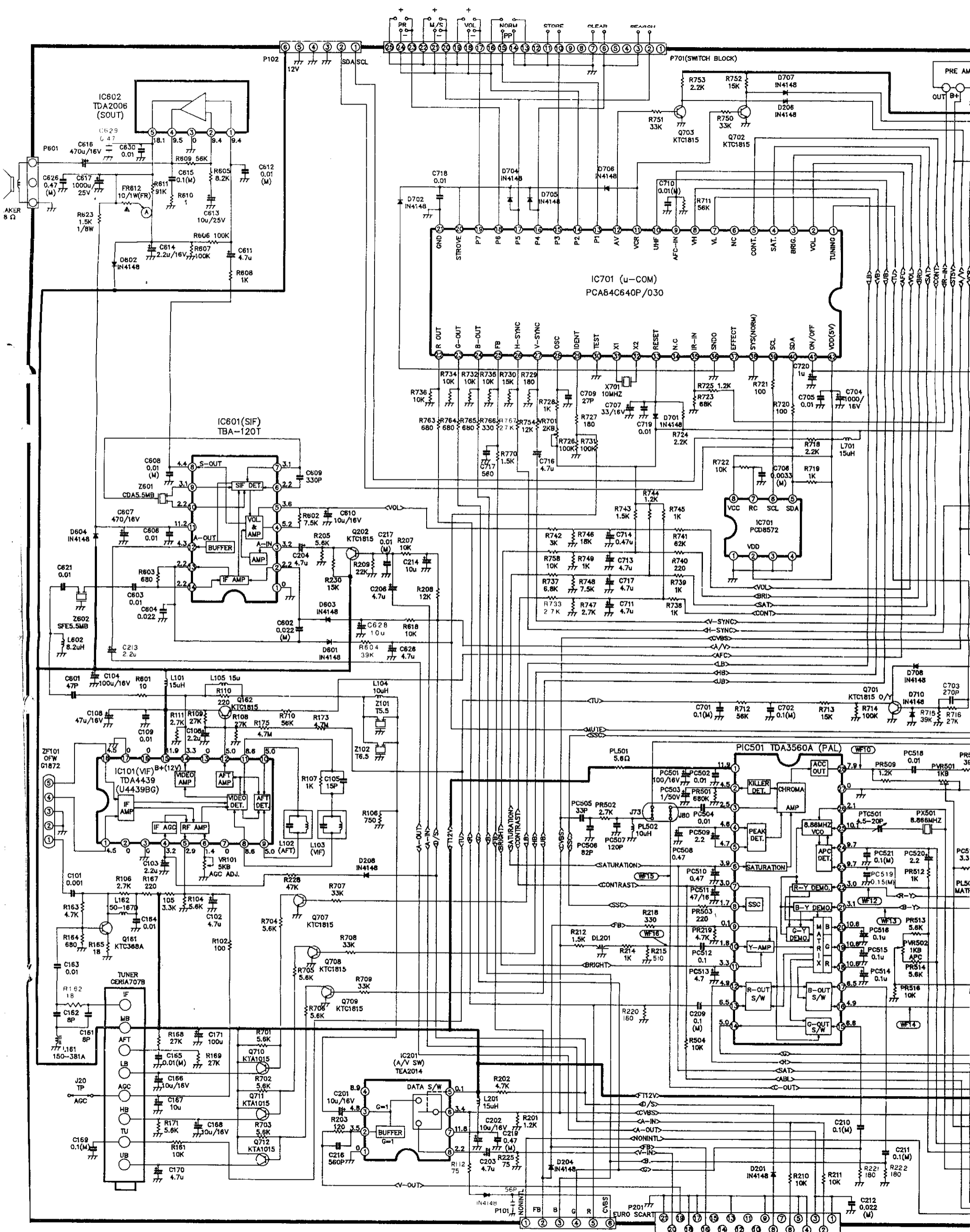

CIRCUIT DIAGRAM(PC04A) MAIN

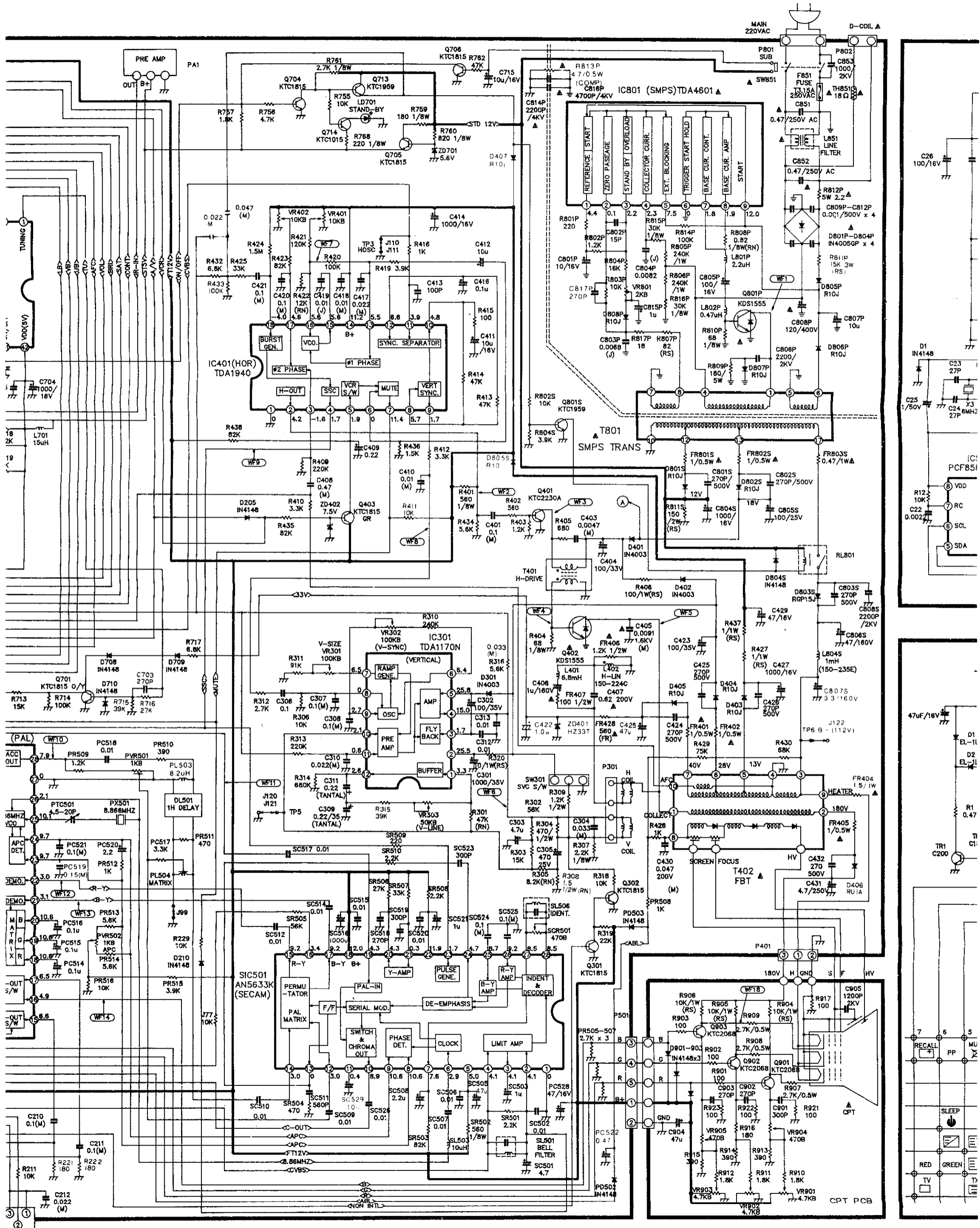

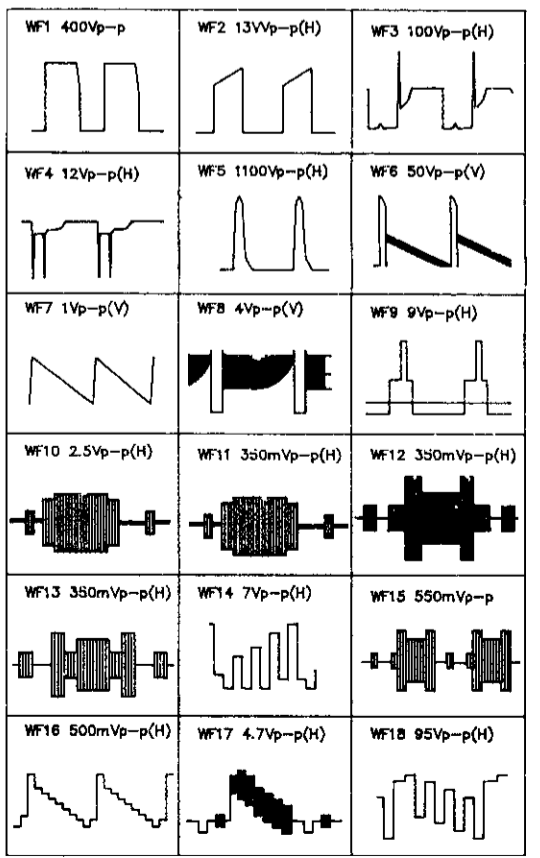
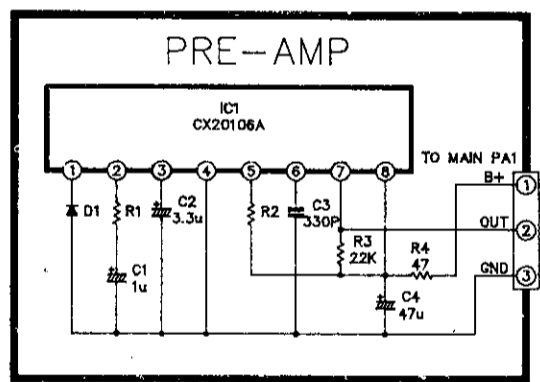
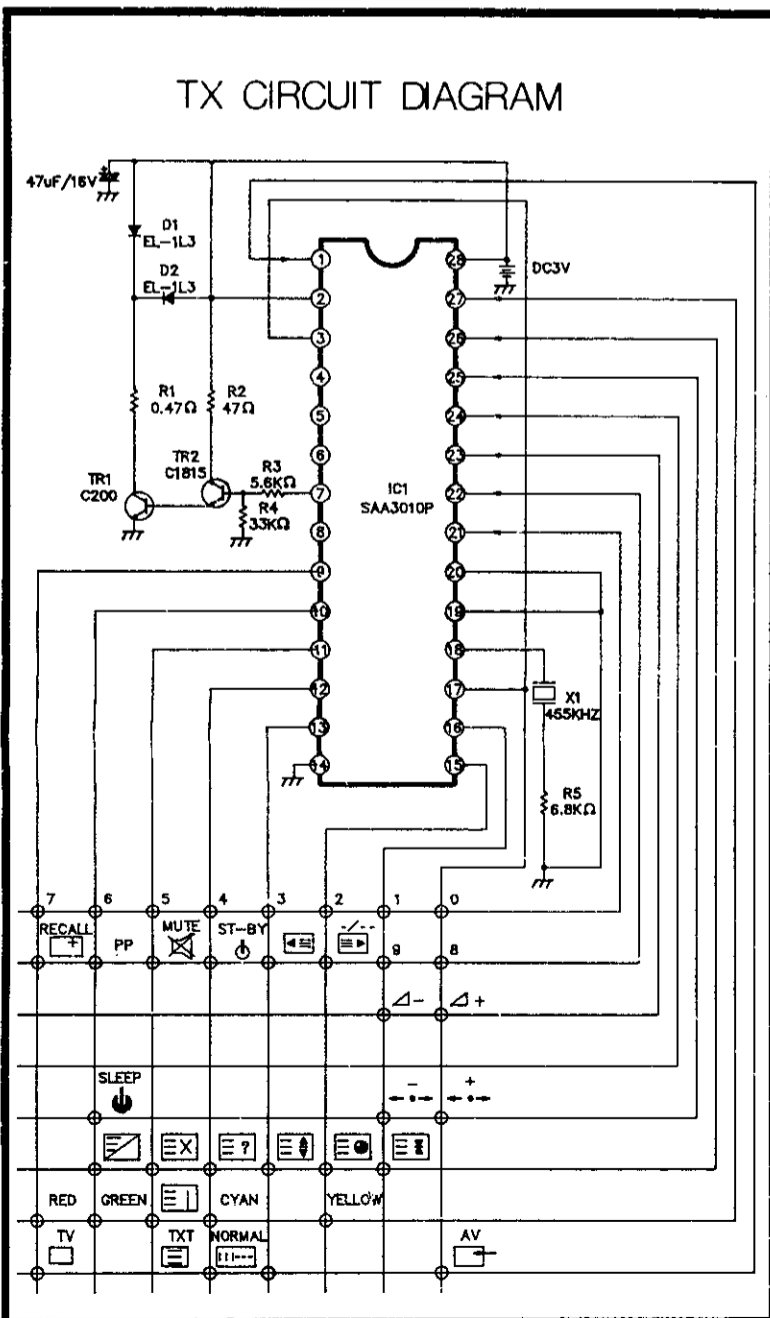
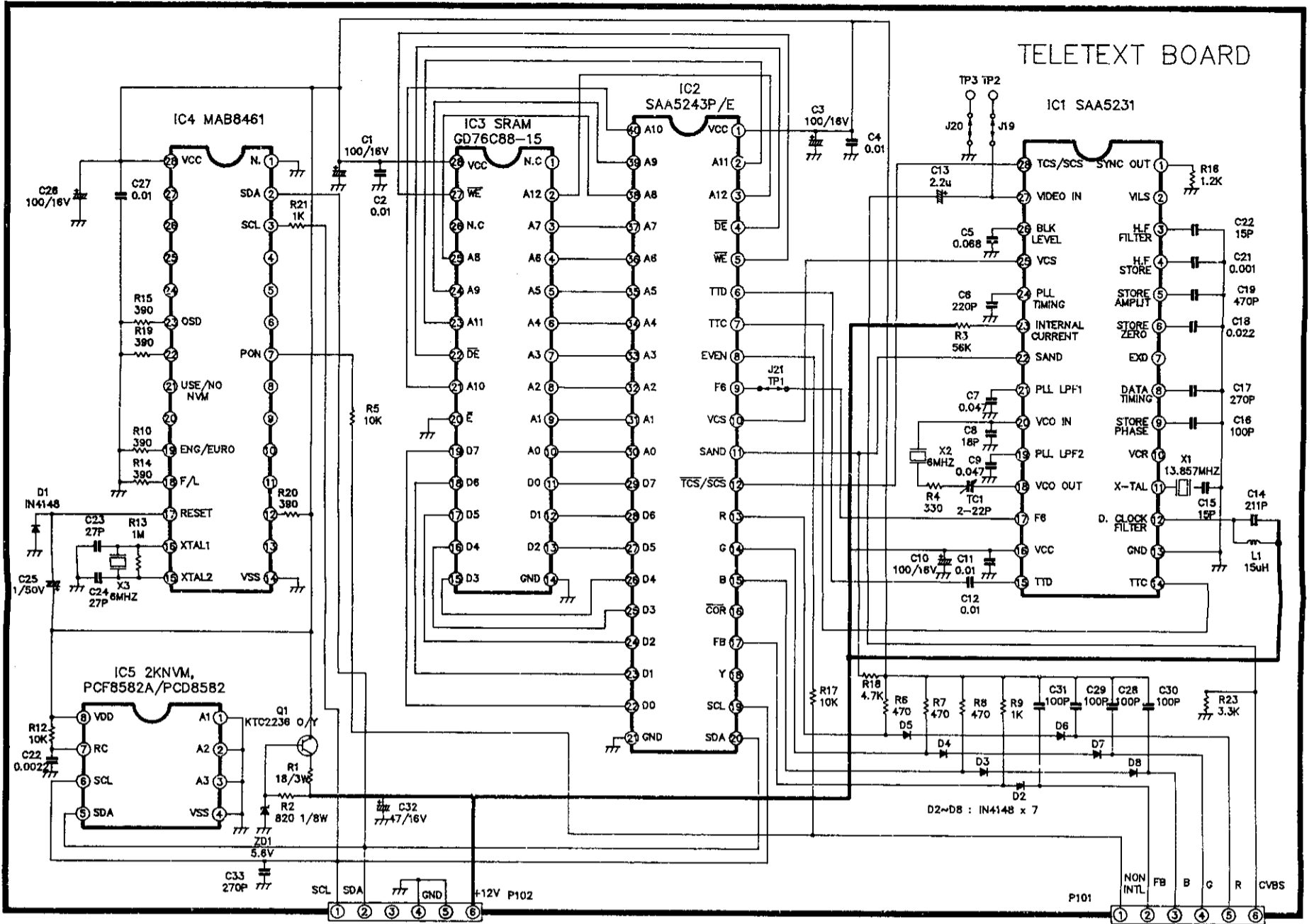
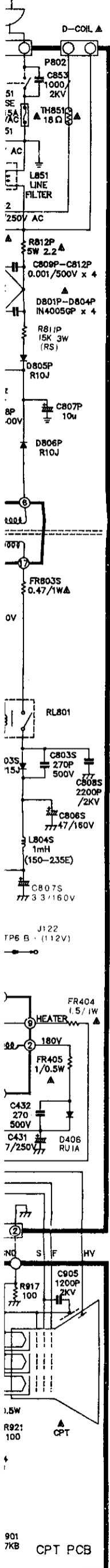

TABLE OF INCH CONVERSION (TABLE 1)

CIRCUIT NO.	INCH			REMARK
	14"	20"	21"	
R302	47KΩ	58KΩ	58KΩ	CARBON FILM RESISTOR
R311	91KΩ	91KΩ	62KΩ	"
R315	27KΩ	39KΩ	39KΩ	"
R427	1Ω 1W	1.2 1W	1Ω 1W	METAL OXIDE FILM RESISTOR
R437	1Ω 1W	1.5Ω 1W	1Ω 1W	"
R429	10KΩ	56KΩ	75KΩ	CARBON FILM RESISTOR
FR404	1.2Ω	1.5Ω	1.5Ω	FUSIBLE RESISTOR
FR428	390Ω	1.2K	560Ω	"
C303	3.3uF	4.7uF	4.7uF	CE CAPACITOR
C405	0.0073/1.6KV	0.0091/1.6KV	0.0091/1.6KV	MPP CAPACITOR
C407	0.39/200V	0.47/200V	0.47/200V	"
L401	3.3uH	6.8uH	6.8uH	PEAKING COIL
L402	150-224L	150-224C	150-224C	LINEARITY COIL
T402	154-064F	154-177J	154-194B	FBT

NOTICE
 Since this is a basic circuit diagram, the value of components and some partial connection are subject to be changed for improvement.

The components marked Δ conform to VDE or IEC guidelines and are essential for safe operation of the set, while those marked * are required for correct operation. Use specified parts only when replacing.

- VALUE OF RESISTOR, CAPACITOR and INDUCTOR**
- Resistances is shown in ohm, k=1,000, M=1,000,000.
 - Unless other wise noted in schematic, all capacitor values less than 1 are expressed in mfd and the values more than 1 in μF.
 - Unless other wise noted in schematic, all inductor values more than 1 are expressed in uH, and the values less than 1 in nH.

- OBSERVATION OF VOLTAGES AND WAVEFORMS**
- Voltages read with VTVM from point shown to chassis ground, line voltages 180~270V volts, colour bar signal.
 - Voltages reading may vary ±20%.
 - The schematic shown is representative only.
 - All waveforms are taken using a wide band oscilloscope and a low capacity probe.
 - Check FINE TUNING, AGC, BRIGHTNESS, CONTRAST and COLOUR controls for best picture, make sure that CONTRAST and COLOUR controls are in mid position and BRIGHTNESS controls is almost in maximum position.
 - Waveforms are taken using a standard colour bar signal.