

PRICE \$1.00



Assembling
and Using Your...

Heathkit

COMMUNICATIONS TYPE
RECEIVER

MODEL AR-3

from Mickey

HEATH COMPANY

A Subsidiary of Daystrom Inc.

BENTON HARBOR, MICHIGAN

STANDARD COLOR CODE — RESISTORS AND CAPACITORS

AXIAL LEAD RESISTOR

INSULATED UNINSULATED Color	FIRST RING BODY COLOR First Figure	SECOND RING END COLOR Second Figure	THIRD RING DOT COLOR Multiplier
BLACK	0	0	None
BROWN	1	1	0
RED	2	2	00
ORANGE	3	3	,000
YELLOW	4	4	0,000
GREEN	5	5	00,000
BLUE	6	6	000,000
VIOLET	7	7	0,000,000
GRAY	8	8	00,000,000
WHITE	9	9	000,000,000

DISC CERAMIC RMA CODE

RADIAL LEAD DOT RESISTOR

5-DOT RADIAL LEAD CERAMIC CAPACITOR

EXTENDED RANGE TC CERAMIC HICAP

RADIAL LEAD (BAND) RESISTOR

BY-PASS COUPLING CERAMIC CAPACITOR

AXIAL LEAD CERAMIC CAPACITOR

The standard color code provides all necessary information required to properly identify color coded resistors and capacitors. Refer to the color code for numerical values and the zeroes or multipliers assigned to the colors used. A fourth color band on resistors determines tolerance rating as follows: Gold = 5%, silver = 10%. Absence of the fourth band indicates a 20% tolerance rating.

The physical size of carbon resistors is determined by their wattage rating. Carbon resistors most commonly used in Heath-kits are 1/2 watt. Higher wattage rated resistors when specified are progressively larger in physical size. Small wire wound resistors 1/2 watt, 1 or 2 watt may be color coded but the first band will be double width.

MOLDED MICA TYPE CAPACITORS

CURRENT STANDARD CODE

JAN & 1948 RMA CODE

RMA 3-DOT (OBSOLETE) RATED 500 W.V.D.C. ± 20% TOL.

BUTTON SILVER MICA CAPACITOR

RMA (5-DOT OBSOLETE CODE)

RMA 6-DOT (OBSOLETE)

RMA 4-DOT (OBSOLETE)

MOLDED PAPER TYPE CAPACITORS

TUBULAR CAPACITOR

Normally stamped for value

A 2 digit voltage rating indicates more than 900 V. Add 2 zeros to end of 2 digit number.

MOLDED FLAT CAPACITOR Commercial Code

JAN. CODE CAPACITOR

The tolerance rating of capacitors is determined by the color code. For example: red = 2%, green = 5%, etc. The voltage rating of capacitors is obtained by multiplying the color value by 100. For example: orange = 3 × 100 or 300 volts. Blue = 6 × 100 or 600 volts.

In the design of Heathkits, the temperature coefficient of ceramic or mica capacitors is not generally a critical factor and therefore Heathkit manuals avoid reference to temperature coefficient specifications.

ASSEMBLY AND OPERATION OF THE HEATHKIT COMMUNICATIONS TYPE RECEIVER MODEL AR-3

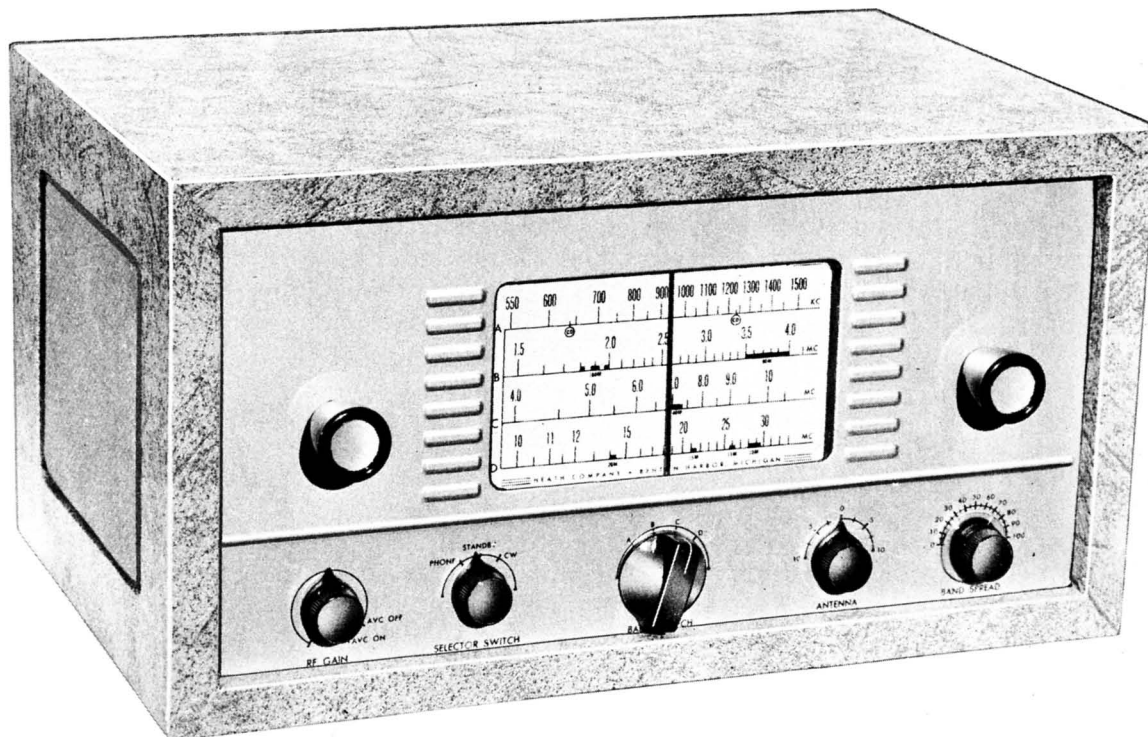

SPECIFICATIONS

Frequency Range:.....	550 kc to 30 mc in four bands
Tube Complement:.....	1 - 12BE6 oscillator and mixer 1 - 12BA6 IF amplifier 1 - 12AV6 second detector, AVC, first audio amplifier, reflex BFO and noise limiter 1 - 12V6GT beam power output 1 - 5Y3 full wave rectifier
Power Requirements:.....	105-125 volts AC 50-60 cycles 40 watts
Dimensions:.....	11 1/2" wide x 5 3/4" high x 6 3/4" deep
Shipping Weight:.....	12 lbs.
Civil Defense frequencies and Amateur bands plainly marked on dial.	

CONTROLS

General Coverage Tuning	Band Switch
Band Spread Tuning	Noise Limiter On/Off
Phone-Standby-CW Switch	RF Gain Control/AVC On/Off
Headphone Jack	AC On/Off - Audio Gain
Antenna Trimmer	Accessory Socket
Sockets for connecting Heathkit model QF-1 Q Multiplier on rear of chassis.	

INTRODUCTION

The Heathkit model AR-3 Communications Type Receiver is designed to provide all of the features normally found in a receiver costing much more. Simplicity and ease of construction have been accomplished through the use of highly efficient, straightforward circuitry and a very practical chassis layout. All components have been selected carefully for quality and durability.

Four frequency bands, in conjunction with direct planetary drive, provide continuous tuning from 550 kc to 30 mc. No communication type receiver would be complete without bandspread. The AR-3 has been equipped with electrical bandspread that operates at optimum efficiency on all frequency ranges.

For CW reception, a BFO circuit may be switched into operation by means of the SELECTOR switch. When listening on CW, it is desirable to deactivate the normal AVC circuit and control the sensitivity manually. Both functions are accomplished by the RF GAIN control. The STANDBY position of the selector switch allows operating temperatures to be maintained so that the operator may select instantly the type of reception desired.

The NOISE LIMITER switch at the rear of the chassis is used to minimize the interference caused by sharp transient pulses such as ignition noise, etc. The kit is complete with a transformer operated power supply and a 5 1/2" PM dynamic loudspeaker. Functional styling and the easily read dial assembly will contribute greatly to the receiver's attractiveness and ease of operation.

CIRCUIT DESCRIPTION

The signal is applied through the antenna coil of the selected frequency band to the signal grid of a 12BE6 tube, used as a combination oscillator and mixer. The ANTENNA TRIMMER allows peaking the input circuit for maximum signal gain. A 100 Ω suppressor resistor is used in series with the grids to insure maximum stability. The antenna and oscillator sections of this tube are tuned simultaneously by means of the dual tuning capacitor and bandspread capacitor. The oscillator signal appearing at the oscillator grid of the same tube causes a heterodyne action to take place. A 455 kc signal is the result of this mixing and it is amplitude modulated by the audio portion of the RF signal. This intermediate frequency is amplified by the IF amplifier tube, 12BA6. Coupling into and out of the IF stage is accomplished through high gain miniature IF transformers. Most of the sensitivity and selectivity of the receiver is developed in this section. One position of the switch in the cathode circuit of this tube allows normal operation with 820 Ω as the cathode resistance. The other position shorts AVC to ground and makes the cathode resistance variable. This constitutes the RF GAIN control.

After IF amplification, the signal is coupled to one of the diode plates of the second detector tube, 12AV6. The positive signal peaks cause the diode to conduct, charge the diode filter condenser and develop a filtered voltage across the volume control. AVC voltage is present at the high side of the control and is coupled through a filter network to both the mixer and IF stages. Coupling is made from the volume control through a .02 μ fd condenser to the control grid of the triode section on the 12AV6 tube. This section acts as the first audio amplifier (and reflex BFO when the PHONE-STANDBY-CW switch is in the CW position.)

From the plate of the 12AV6, the audio signal is applied through a .01 μ fd condenser to the control grid of a beam power pentode, 12V6. After power amplification, the signal is matched to the speaker voice coil through the output transformer. A 10 Ω resistor provides proper matching when headphones are used. The closed-circuit jack opens the speaker voice coil circuit when headphones are plugged in, eliminating the need for a separate switch.

In the 12AV6 tube, there is a connection between the other diode plate and the control grid of the 12V6, through a SPST slide switch. This is the noise limiter circuit. With the switch closed, the diode plate clamps the grid of the output tube to the average amplitude of the audio signal present. If a sharp noise pulse occurs, the positive peaks will be eliminated by the clamping action of the diode. Atmospheric and other similar types of interference will, therefore, be greatly subdued.

When the signal input to the receiver is CW, no demodulation can take place in the second detector because there are no signal amplitude variations. Another signal becomes necessary in order that the difference between it and 455 kc may be audible. This signal is provided by the BFO circuit which consists of a BFO coil and appropriate resistors and condensers. The circuit is activated by the selector switch. The BFO is a reflex circuit utilizing the triode section of the 12AV6 as oscillator, while still allowing it to function as the first AF amplifier. BFO injection to the second detector diode is accomplished through the tube and magnitude of injection voltage is automatically controlled by tube characteristics. The BFO signal is isolated from the 12V6 grid by an RF filter consisting of a 22 K Ω resistor. The BFO grid circuit is isolated from the AF gain control by a 220 K Ω resistor.

In the CW position, the ground is removed from the tap of the BFO coil, allowing it to function properly in conjunction with the 12AV6 triode section. In the STANDBY position of the selector switch, the BFO circuit is grounded, the B- return circuit of the complete receiver is opened, and B+ is removed from the screen grids of the mixer and IF tubes. In the PHONE position, the B- and screen circuits are completed while the BFO remains grounded. Tube filaments are activated at all times to provide instantaneous operation of any circuit when the switch is manipulated.

NOTES ON ASSEMBLY AND WIRING

The Heathkit model AR-3 Communications Receiver, when constructed in accordance with the instructions in this manual, is a high-quality unit capable of many years of trouble-free service. We therefore urge you to take the necessary time to assemble and wire the kit carefully. Do not hurry the work and you will be rewarded with a greater sense of confidence, both in your receiver and in your own ability.

This manual is supplied to assist you in every way to complete the kit with the least possible chance for error. We suggest that you take a few minutes now and read the entire manual through before any work is started. This will enable you to proceed with the work much faster when construction is started. The large fold-in pictorials are handy to attach to the wall above your work space. Their use will greatly simplify the completion of the kit. These diagrams are repeated in smaller form within the manual. We suggest that you retain the manual in your files for future reference, both in the use of the receiver and for its maintenance.

UNPACK THE KIT CAREFULLY AND CHECK EACH PART AGAINST THE PARTS LIST. In so doing, you will become acquainted with each part. Refer to the charts and other information shown on the inside covers of the manual to help you identify any parts about which there may be a question. If some shortage is found in checking the parts, please notify us promptly and return the inspection slip with your letter to us. Hardware items are counted by weight and if a few are missing, please obtain them locally if at all possible.

Read the notes on soldering on Pages 8, 9 and 10. Crimp all leads tightly to the terminal before soldering. Be sure that both the lead and the terminal are clean of wax, corrosion or other foreign substances. Use only the best rosin core solder, preferably a type containing the new activated fluxes such as Kester "Resin-Five," Ersin "Multicore" or similar types.

NOTE: ALL GUARANTEES ARE VOIDED AND WE WILL NOT REPAIR OR SERVICE INSTRUMENTS IN WHICH ACID CORE SOLDER OR PASTE FLUXES HAVE BEEN USED. WHEN IN DOUBT ABOUT SOLDER, IT IS RECOMMENDED THAT A NEW ROLL PLAINLY MARKED "ROsin CORE RADIO SOLDER" BE PURCHASED.

Resistors and controls generally have a tolerance rating of $\pm 20\%$ unless otherwise stated in the parts list. Therefore, a 100 K Ω resistor may test anywhere from 80 K Ω to 120 K Ω . (The letter K is commonly used to designate a multiplier of 1000.) Tolerances on condensers are generally even greater. Limits of +100% and -50% are common for electrolytic condensers. Parts furnished with your Heathkit have been specified to enable you to obtain maximum performance from the finished instrument.

In order to expedite delivery to you, we are occasionally forced to make minor substitutions of parts. Such substitutions are carefully checked before they are approved and the parts supplied will function satisfactorily. By checking the parts list for resistors, for example, you may find that a 2.2 megohm resistor has been supplied in place of a 2 megohm resistor as shown in the parts list. These changes are self-evident and are mentioned here only to prevent confusion in checking the contents of your kit.

We strongly urge that you follow the wiring and parts layout shown in this manual. The position of wires and parts is quite critical in this instrument and changes may seriously affect the characteristics of the circuit.

STEP-BY-STEP ASSEMBLY INSTRUCTIONS

The following instructions are presented in a simple, logical, step-by-step sequence to enable you to complete your kit with maximum facility. Be sure to read each step all the way through before you start to do it. When the step is completed, check it off in the space provided.

We suggest that you do the following before any work is started:

1. As each phase of construction is begun, select the proper large fold-in pictorial and attach it to the wall above your work bench.
2. Lay out all parts so that they are readily available. Refer to the general information inside the front and back covers of this manual to help you identify components. Identification of the coils and mica condensers used in the coil turret are particularly important.
3. Special care should be exercised when handling the coils in order that the windings will not be disturbed.
4. The speaker cone can easily be damaged and it should be protected during all phases of construction.
5. The bandsread, antenna trimmer and tuning condenser shafts should be rotated fully counterclockwise to completely mesh the plates. In this way the plates can be protected from damage during installation.

In assembling the kit, use lockwashers under all nuts except at 7-pin miniature sockets and where solder lugs are used. Tube sockets and the condenser mounting wafer are installed from the inside of the chassis. All screws are mounted with the heads on top of the chassis, except for those used with the tuning condenser. Other details of construction are included where pertinent in the instructions.

() Place the chassis upside down on the bench, with the triangular shaped cutout on your right. It will then be properly oriented with the front facing you as in Pictorial 1 on Page 6. It will be helpful to mark each locating hole with its identification letter with a grease pencil.

() Install the metal condenser mounting wafer in position B using 6-32 x 3/8 screws and nuts and #6 lockwashers. One flat edge of the cutout in the wafer should run parallel to the rear of the chassis as in Pictorial 1. Mount the cable clamp under the screw closest to the chassis cutout. Do not tighten this screw yet. See Figure 1.

() Mount the power transformer as shown in Pictorial 2 on Page 6 with 8-32 screws and nuts and #8 lockwashers. The bottom plate of the transformer should be flush with the right and rear edges of the chassis. It is positioned so that the two green leads and the two black leads can be inserted through the large hole nearest the edge of the chassis. Use a #8 solder lug instead of a lockwasher on the screw nearest the front and side of the chassis.

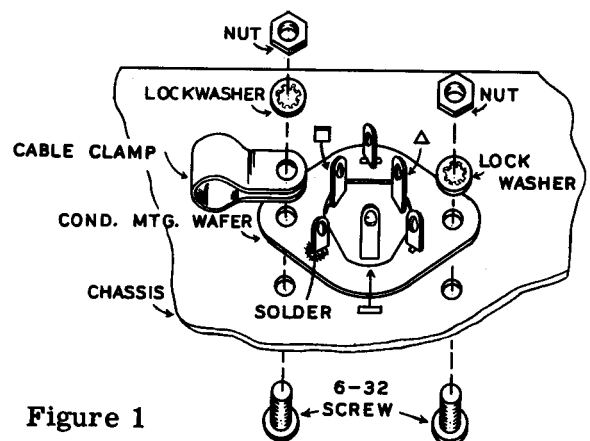
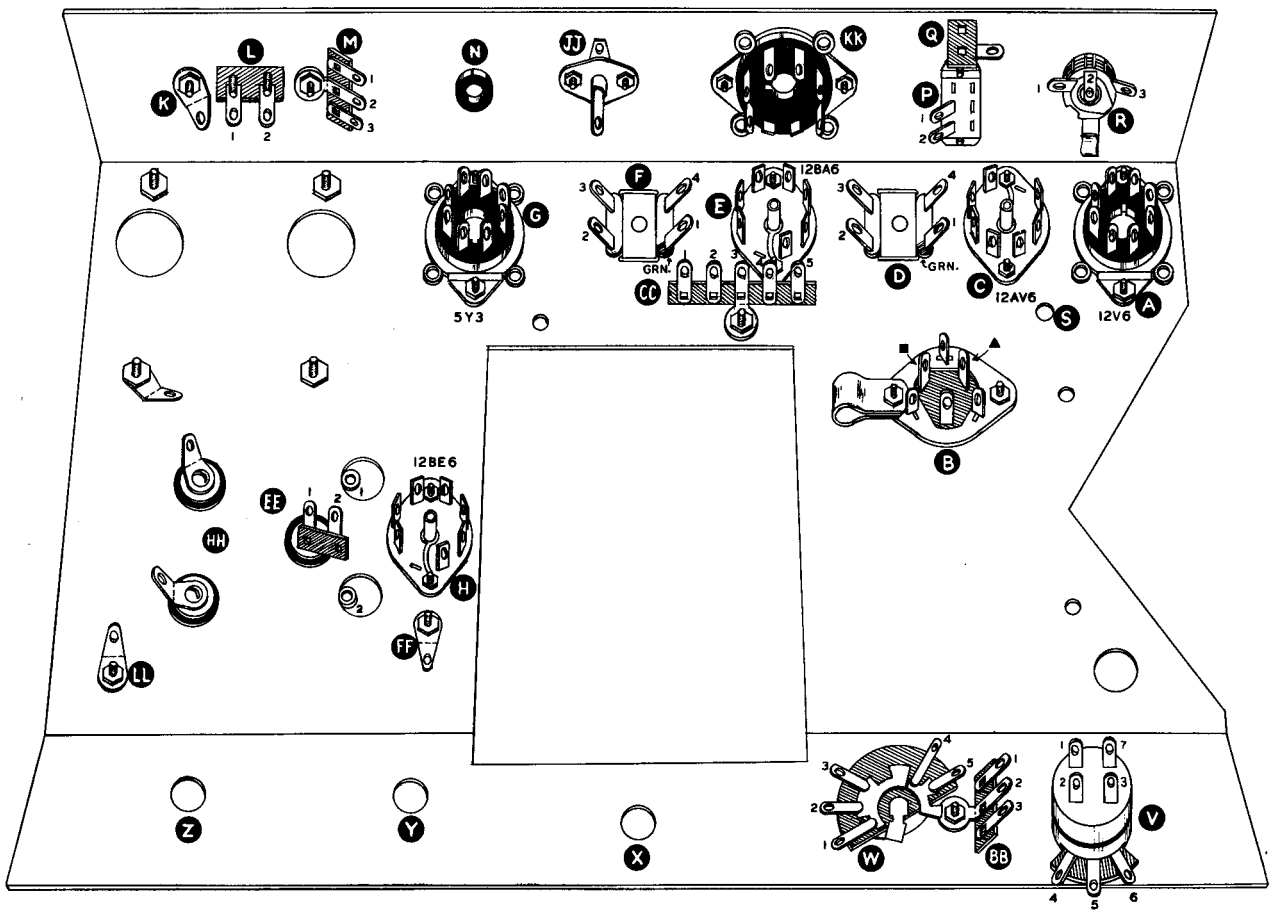
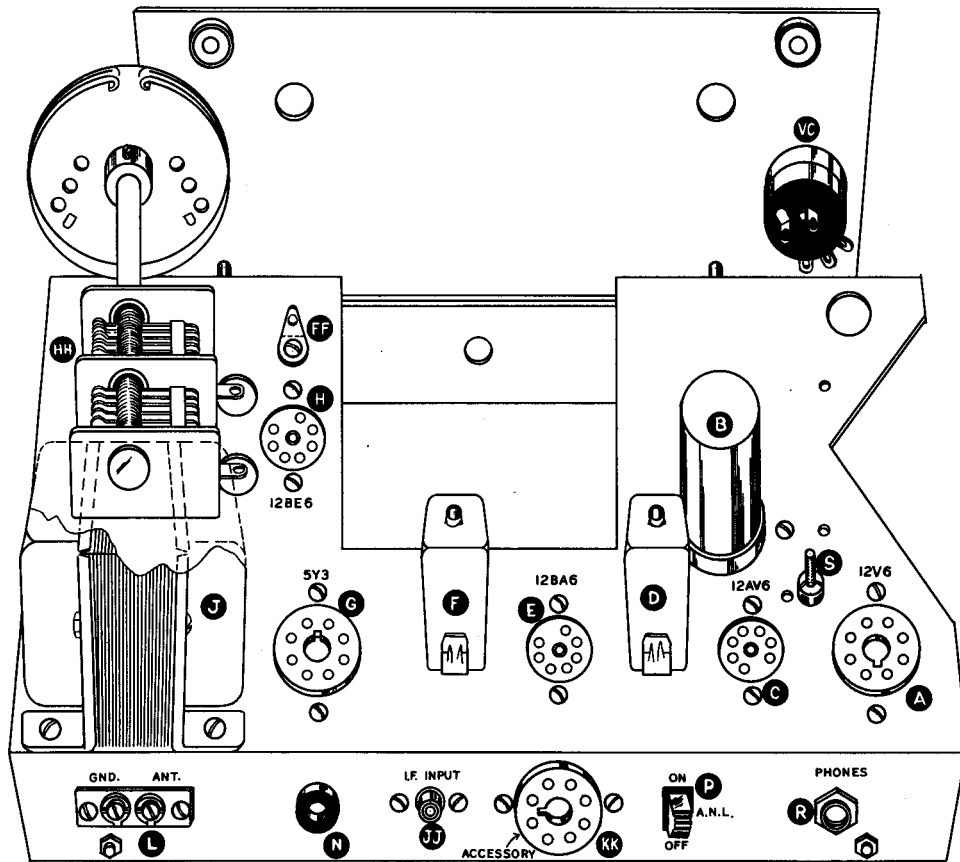

Figure 1



PICTORIAL 1



PICTORIAL 2

- () Insert the 3/8" grommet in hole N.
- () Insert the three 7/16" soft rubber grommets in the three capacitor mounting holes at HH.
- () Install the 3-section filter capacitor from the top of the chassis at B. See Pictorials 1 and 2. The unmarked lug should be located closest to the front of the chassis. Holding the capacitor firmly in place against the mounting wafer, twist each of the three mounting lugs about 1/8 turn with pliers.

NOTE: The 7-pin miniature sockets are composed of 2 individual wafers. It is possible that one wafer may be rotated 180° with respect to the other. Each socket should be inspected to be certain that such a rotation has not accidentally occurred and that pin 1, looking at the bottom, corresponds to pin 1, looking at the top. See Figure 2.

- () Note that the contacts on the tube sockets are numbered in clockwise sequence as viewed from the bottom. The two octal sockets have a keyway between terminals 1 and 8 while the 7-pin miniature sockets have extra wide spacing between terminals 1 and 7. Mount a 7-pin miniature socket in position H with the wide spacing located toward the front of the chassis. Use 3-48 screws and nuts.

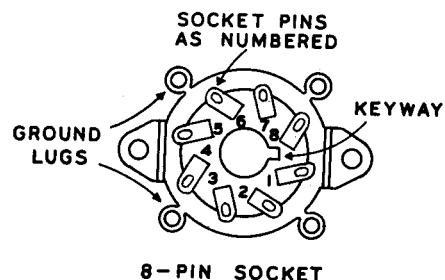
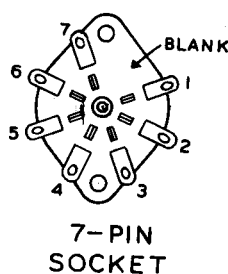

Figure 2

- () Mount 7-pin socket E in the same manner with wide spacing toward front of the chassis.
- () Install the SPST slide switch P with 6-32 x 3/8" screws and nuts and #6 lockwashers. Note position of lugs in Pictorial 1. Mount a 1-lug terminal strip at Q between switch and chassis.
- () Mount 7-pin socket C with the wide spacing toward the rear of the chassis.
- () Mount an octal socket at KK, position as shown. Clip the lugs from pins 6 and 7 before mounting this socket. Use 6-32 x 3/8" screws, nuts and #6 lockwashers.
- () Mount the octal socket at G with the keyway toward the front of the chassis as in Pictorial 1. Use 6-32 x 3/8" screws, nuts and #6 lockwashers.
- () Mount octal socket A as above, with the keyway toward the rear of the chassis.
- () Install the single terminal IF input jack at JJ. Use 6-32 screws, nuts and #6 lockwashers.
- () Install the 3-lug (center-lug grounded) insulated terminal strip BB. See Pictorial 1.
- () Mount screw-type terminal strip L outside chassis with 6-32 hardware as in Pictorial 1. Under the nut nearest the edge of the chassis, mount solder lug K. Use a #6 lockwasher with 3-lug terminal strip M under other nut.
- () Install 5-lug (center-lug grounded) terminal strip CC as in Pictorial 1. Use a 6-32 spade bolt and nut and a #6 lockwasher. Do not tighten unnecessarily.
- () Mount an IF transformer from top of chassis in position F. Green dot should be located nearest socket E. Hold transformer in place and press IF transformer mounting clip over it from inside chassis as shown in Figure 3. Clip should engage cutouts on opposite sides of transformer.

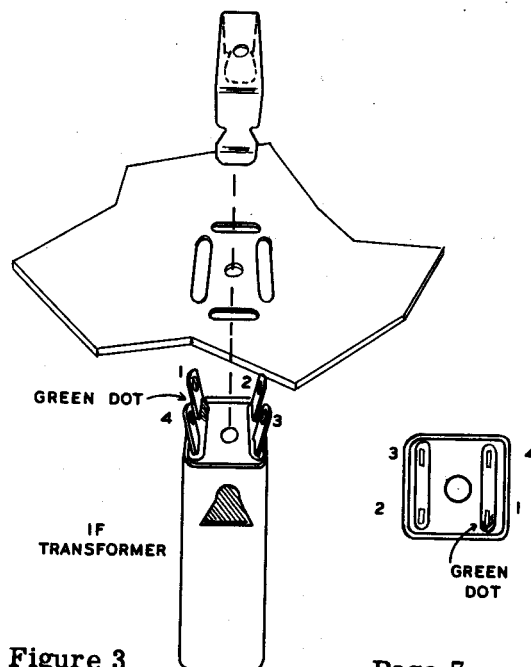

Figure 3

- () In the same manner, install the other IF transformer in position D, Pictorial 1. Place the green dot on the side nearest socket C.
- () Mount the tuning capacitor HH as in Pictorial 2. Use 6-32 x 3/8 screws, large flat washers, 3/16" spacers and solder lugs on the two holes nearest the chassis edge. A 2-lug terminal strip EE, lockwasher, flat washer and 3/16" spacer are used at the third hole. Refer to Pictorial 1 and Figure 4.
- () Mount a solder lug at LL.
- () Mount the single wafer rotary switch at W, Pictorial 1, using a 3/8 lockwasher inside the chassis and a 3/8-32 control nut and flat washer on the outside. Refer to Figure 5.
- () In the same manner, install the 10 K Ω RF gain control in position V.

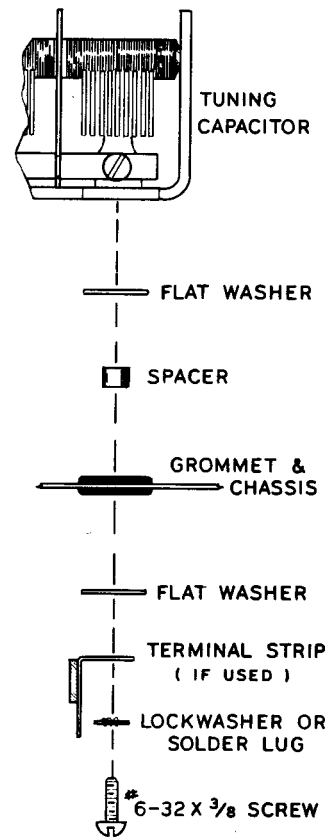

Figure 4

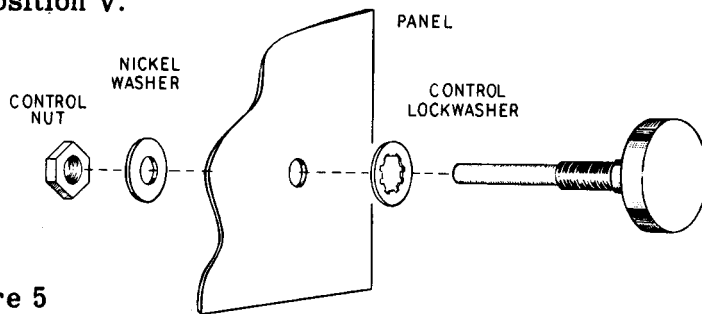
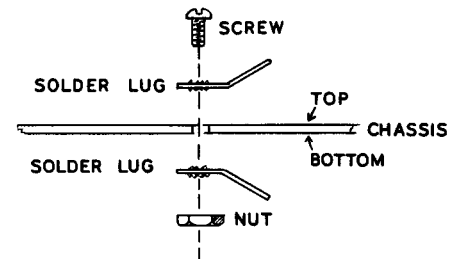

Figure 5

HOW TO MOUNT CONTROLS & SWITCHES.



DETAIL AT "FF"

Figure 6

- () Mount the solder lugs FF using a 6-32 x 3/8 screw and nut. Place a solder lug on the screw on top of the chassis before inserting the screw. See Figure 6.
- () Install the phone jack R as shown in Pictorial 1.

NOTE: The "phono" jack on the rear of your AR-3 is for use only with the QF-1 "Q" Multiplier. It is not a phonograph input, and if a phonograph is plugged into this jack, the cartridge will be destroyed. The AR-3 has no provision for use with external phonographs or turntables.

NOTE: Several parts have been left unmounted to facilitate wiring.

WIRING OF THE CHASSIS

It is suggested that the large fold-in pictorial be referred to for each step in the following wiring procedure. It represents the completed bottom view of the chassis except for the speaker and bandswitch and the components common to each.

Read the notes on the inside rear cover and those immediately following concerning wiring and soldering.

PROPER SOLDERING PROCEDURE

Only a small percentage of Heathkit purchasers find it necessary to return an instrument for factory service. Of these, by far the largest proportion function improperly due to poor or improper soldering.

Correct soldering technique is extremely important. Good solder joints are essential if the performance engineered into the kit is to be fully realized. If you are a beginner with no experience in soldering, a half-hour's practice with odd lengths of wire and a tube socket will be a worthwhile investment.

High quality solder of the proper grade is most important. There are several different brands of solder on the market, each clearly marked "Rosin Core Radio Solder." Such solders consist of an alloy of tin and lead, usually in the proportion of 50:50. Minor variations exist in the mixture such as 40:60, 45:55, etc. with the first figure indicating the tin content. Radio solders are formed with one or more tubular holes through the center. These holes are filled with a rosin compound which acts as a flux or cleaning agent during the soldering operation.

NO SEPARATE FLUX OR PASTE OF ANY KIND SHOULD BE USED. We specifically caution against the use of so-called "non-corrosive" pastes. Such compounds, although not corrosive at room temperatures, will form residues when heated. The residue is deposited on surrounding surfaces and attracts moisture. The resulting compound is not only corrosive but actually destroys the insulation value of non-conductors. Dust and dirt will tend to accumulate on these "bridges" and eventually will create erratic or degraded performance of the instrument.

NOTE: ALL GUARANTEES ARE VOIDED AND WE WILL NOT REPAIR OR SERVICE INSTRUMENTS IN WHICH ACID CORE SOLDER OR PASTE FLUXES HAVE BEEN USED. WHEN IN DOUBT ABOUT SOLDER, IT IS RECOMMENDED THAT A NEW ROLL PLAINLY MARKED "ROsin CORE RADIO SOLDER" BE PURCHASED.

If terminals are bright and clean and wires free of wax, frayed insulation and other foreign substances, no difficulty will be experienced in soldering. Crimp or otherwise secure the wire (or wires) to the terminal, so a good joint is made without relying on solder for physical strength. To make a good solder joint, the clean tip of the soldering iron should be placed against the joint to be soldered so that the terminal is heated sufficiently to melt solder. The solder is then placed against both the terminal and the tip of the iron and will immediately flow out over the joint. Refer to the sketch below. Use only enough solder to cover wires at the junction; it is not necessary to fill the entire hole in the terminal with solder. Excess solder may flow into tube socket contacts, ruining the socket, or it may creep into switch contacts and destroy their spring action. Position the work so that gravity tends to keep the solder where you want it.

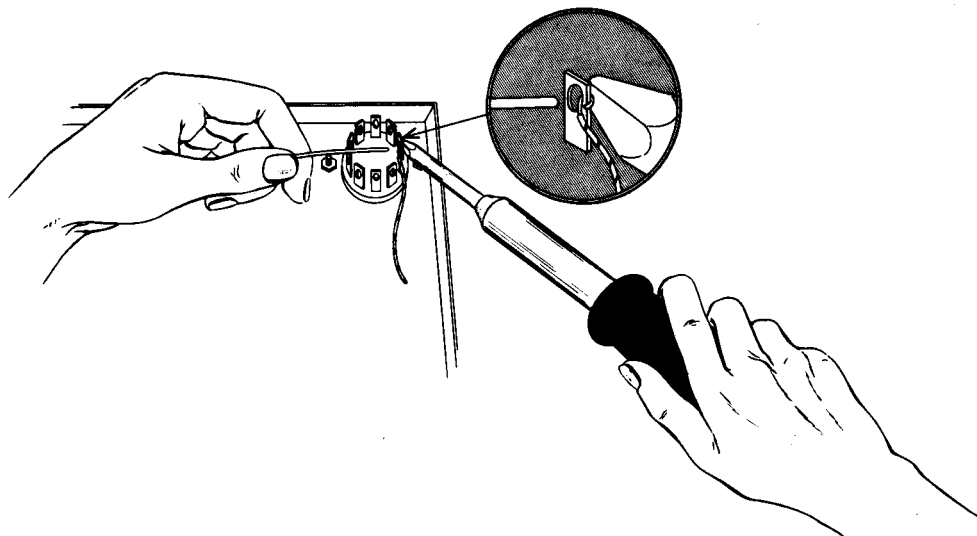

A poor solder joint will usually be indicated by its appearance. The solder will stand up in a blob on top of the connection, with no evidence of flowing out caused by actual "wetting" of the contact. A crystalline or grainy texture on the solder surface, caused by movement of the joint before it solidified is another evidence of a "cold" connection. In either event, reheat the joint until the solder flows smoothly over the entire junction, cooling to a smooth bright appearance. Photographs in the adjoining picture clearly indicate these two characteristics.

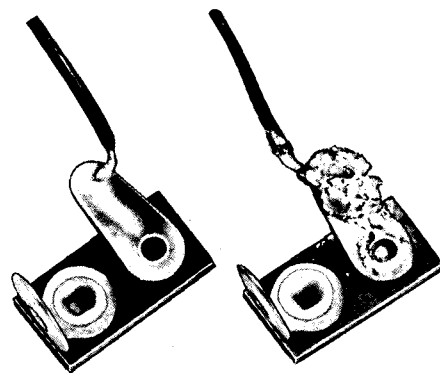

A good, clean, well-tinned soldering iron is also important to obtain consistently perfect connections. For most wiring, a 60 or 100 watt iron, or the equivalent in a soldering gun, is very satisfactory. Smaller irons generally will not heat the connections enough to flow the solder smoothly over the joint and are recommended only for light work, such as on etched circuit boards, etc. Keep the iron tip clean and bright. A pad of steel wool may be used to wipe the tip occasionally during use.

Take this precaution and use reasonable care during the assembly of the kit. This will insure the wonderful satisfaction of having the instrument operate perfectly the first time it is turned on.

Note that each component part has been given a code designation which corresponds to the designation used in the assembly of the chassis. Each terminal, however, has also been assigned a number.

For example, when the instructions read, "Connect one end of a $470\ \Omega$ resistor to E7 (S)," it will be understood that the connection is to be made to contact 7 on socket E. The letter "S" indicates that the connection should be soldered. In some cases, more than one lead is connected to the same terminal. The terminal should not be soldered until the last lead is connected and the letters "NS" indicate this.

Unless otherwise stated, all wire used is insulated. Whenever there is a possibility of the bare leads on resistors and condensers shorting to other parts or to the chassis, the leads should be covered with insulated sleeving (spaghetti). This is indicated in the instructions by the phrase "use sleeving."

Leads on resistors, condensers and transformers are generally much longer than needed. In these cases, the excess lead length should be cut off before soldering. Not only does this make the wiring much neater, but in many cases excessively long leads will actually interfere with the proper operation of the receiver.

We very strongly urge that the chassis layout, as described, be followed exactly. While this arrangement may not be the only way in which the receiver may be wired, it is the result of engineering many experimental models. If followed closely, it will result in trouble-free performance of your receiver.

PRELIMINARY WIRING

- () Select either green power transformer lead, clip to the proper length and connect to K (NS). See Pictorial 3 on Page 11.
- () Connect a bare wire between K and L1. Solder both connections.
- () Connect the other green lead to H4 (NS).
- () Connect one red wire to G4 (S).
- () Connect the other red wire to G6 (S).

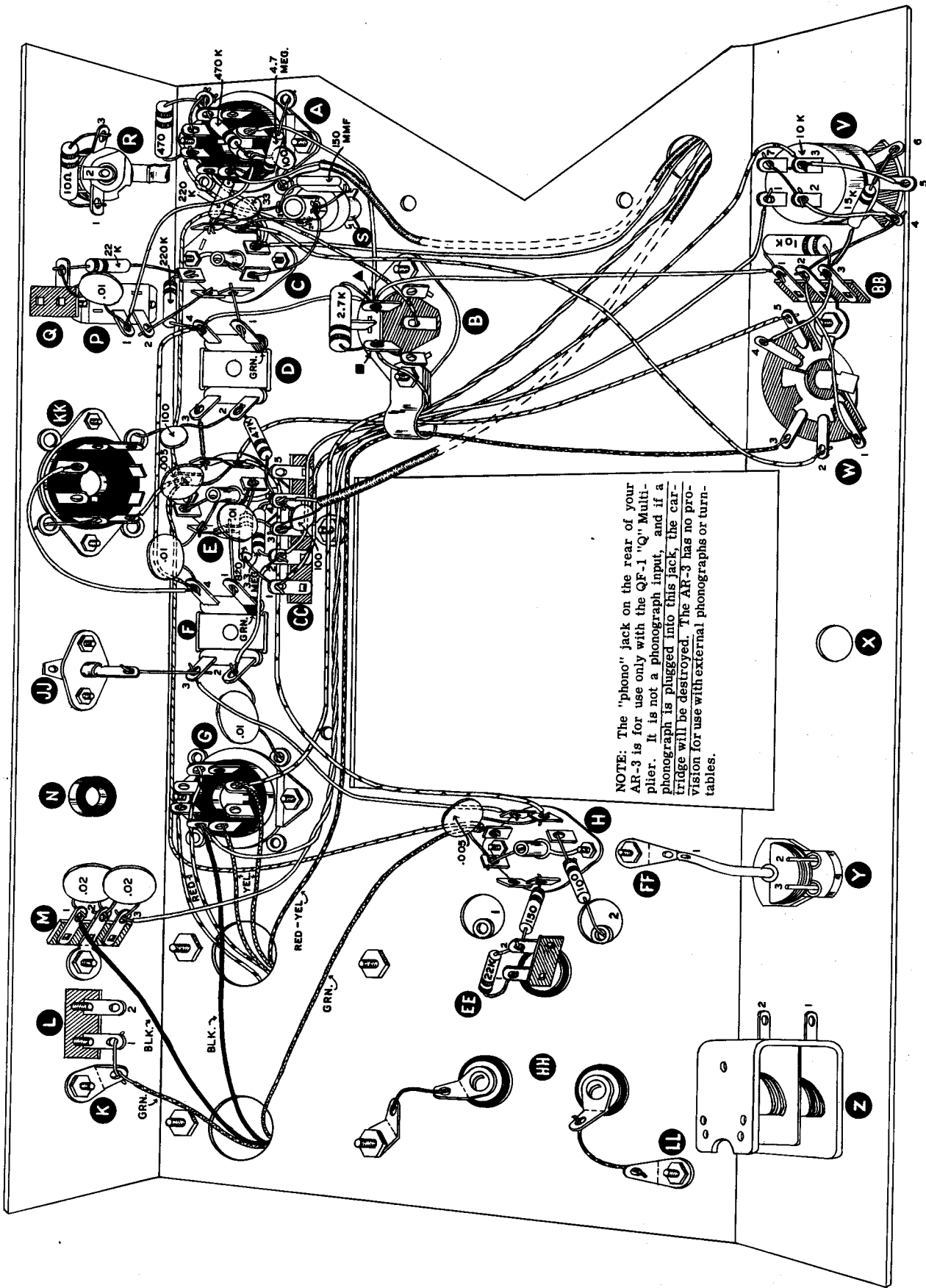

NOTE: The "phono" jack on the rear of your AR-3 is for use with the QF-1 "Q" Multiplier. It is not a phonograph input, and if a phonograph is plugged into this jack, the cartridge will be destroyed. The AR-3 has no provision for use with external phonographs or turntables.

PICTORIAL 3

- () Connect one yellow lead to G2 (S).
- () Connect the other yellow lead to G8 (NS).
- () Connect a wire from H4 (S), straight back to the rear of the chassis and along the rear edge to E4 (NS).
- () Run a wire from E4 (NS) to KK8 (S).
- () Connect a wire from E4 (S) around the output IF transformer to C3 (NS).
- () Connect a 9" wire from C3 (NS) up through the hole near the RF gain control. Leave the other end free.
- () Connect a wire from C3 (S) to A7 (S).
- () Connect one black power transformer lead to M1 (NS).
- () Connect the other black lead to G3 (NS).
- () Connect a .02 μ fd disc capacitor between M1 (NS) and M2 (NS).
- () Connect a .02 μ fd disc capacitor between M2 (S) and M3 (NS).
- () Twist two leads together until the length of the twisted pair reaches approximately 14". At one end, connect one of the leads to G3 (S).
- () Connect the other lead at the same end of the twisted pair to M3 (NS).
- () Run the twisted pair through the cable clamp at B along the chassis cutout and up through the 1/2" hole under the RF gain control V. This end of the twisted pair should be taped or otherwise fastened to the top of the chassis for the time being.
- () Run the red-yellow transformer lead along the twisted pair just installed, through the cable clamp and connect to W3 (S).
- () Connect one end of a 5 3/4" lead to G8 (S).
- () Run the lead along the twisted pair just installed, through the cable clamp and connect it to the ■ marked filter capacitor lug (NS).
- () Run a lead from B ▲ (NS) to A4 (S).
- () Run a lead from B ▲ (NS) to D4 (NS).
- () Solder one of the mounting tabs at B to the metal wafer.
- () Connect a 2700 Ω 2 watt resistor (red-violet-red) from B ▲ (NS) to B ■ (NS).
- () Connect a wire from D4 (NS) to F4 (NS).
- () Connect an .01 μ fd ceramic capacitor from F4 (NS) to E2 (NS).
- () Connect a wire from F3 (NS) to H5 (S).
- () Connect a bare wire from F3 (S) to the center contact of the IF input connector JJ (S).
- () Connect a .01 μ fd ceramic capacitor from F2 (NS) to nearest ground lug on socket G (S).

- () Connect a wire from F2 (S) to CC2 (NS).
- () Connect a wire from F4 (S) to KK3 (S).
- () Connect a 3.3 megohm resistor (orange-orange-green) from CC2 (NS) to CC4 (NS).
- () Connect a 47 K Ω resistor (yellow-violet-orange) from CC4 (NS) to D2 (NS).
- () Connect a 100 $\mu\mu\text{f}$ ceramic capacitor between the ground lug on KK (S) nearest pin 5 and D2 (S).
- () Connect a 150 Ω resistor (brown-green-brown) from H1 (S) to EE2 (NS).
- () Connect a 22 K Ω resistor (red-red-orange) from EE2 (NS) to EE1 (S).
- () Connect a short bare wire from the grounded center of socket H (S) to H3 (NS).
- () Connect a .005 μfd ceramic capacitor from H3 (NS) to H6 (NS).
- () Connect a lead from H6 (S) around the chassis cutout to E6 (NS).
- () Connect a 100 Ω resistor (brown-black-brown) from H7 (S) to tuning capacitor lug HH2 (NS).
- () Connect a short bare wire from F1 (S) to E1 (S).
- () Run one lead of a .005 μfd ceramic capacitor from E3 (S) through the center post (S) to E2 (S).
- () Connect the other capacitor lead to E6 (NS).
- () Run a wire from E6 (S) to W5 (S). Run this lead through the cable clamp at B.
- () Connect a short bare wire from E5 (S) to D3 (S) (use sleeving).
- () Connect one lead of an .01 μfd ceramic capacitor to CC3 (NS). Connect the other lead to E7 (NS).
- () Connect an 820 Ω resistor (gray-red-brown) between E7 (S) and CC1 (NS).
- () Connect a bare wire between KK1 (S) and the ground lug nearest pin 1 (S).
- () Connect a 220 K Ω resistor (red-red-yellow) from D4 (S) to C7 (NS).
- () Connect a 22 K Ω resistor (red-red-orange) from C7 (S) to Q (NS).
- () Run a short bare wire from C5 (S) to D1 (S).
- () Run a bare wire from the grounded center of socket C (S) to C4 (NS).
- () Connect a bare wire from C6 (S) to P2 (S).
- () Connect a wire from the unused terminal on B (S) to A8 (NS).
- () Connect a 470 Ω 1 watt resistor (yellow-violet-brown) from A8 (S) to the ground lug nearest pin 2 of socket A (NS). Place this resistor between socket A and the rear of the chassis.
- () Connect a 470 K Ω resistor (yellow-violet-yellow) from A5 (NS) to A2 (S), through the ground lug nearest pin 2 (S) to A1 (S).

- () Connect a 100 μf ceramic capacitor between A5 (NS) and the nearest ground lug on socket A (NS).
- () Cut a length of Spirashield about 5" long. Unwind the spring at each end to form a straight pigtail about 3/4" long.
- () Strip 1/4" at each end of a 6 1/2" insulated wire and insert it in the Spirashield. Crimp the pigtail around the insulation at one end to prevent slipping.
- () Connect the pigtail at the other end to ground lug nearest A6 (S) and the wire to A6 (NS).
- () Run the Spirashield through the 1/2" hole under the RF gain control. Fasten it to the chassis top for the time being.
- () Connect a 4.7 megohm resistor (yellow-violet-green) between A6 (NS) and the ground lug nearest A3 (S). Use very short leads.
- () Connect a 220 K Ω resistor (red-red-yellow) from C1 (NS) to A6 (S).
- () Connect a .01 μf ceramic capacitor to Q (S). The other lead is wired to P1 (NS).
- () Connect a wire between P1 (S) and A5 (S).
- () Connect a 10 Ω 1 watt resistor (brown-black-black) from R1 (S) to R3 (NS).
- () Prepare another length of Spirashield 5 1/2" long and make pigtails at both ends. Strip a 6 1/2" wire at each end and insert it in the Spirashield. At one end, connect the pigtail to CC3 (NS) and the wire to CC4 (NS).
- () Run the Spirashield straight back to the 1/2" hole under the RF gain control V. Secure the wire temporarily on top of the chassis.
- () Connect a 100 μf ceramic capacitor from CC3 (S) to CC4 (S).
- () Connect a wire from CC2 (NS) along the edge of the chassis cutout to V1 (S). Run this wire through the cable clamp at B.
- () Connect a wire from CC1 (S) parallel to strip CC and back to V3 (NS). Run this wire through the cable clamp at B. Tighten the screw holding the cable clamp.
- () Connect a wire from V3 (S) to V5 (S).
- () Connect a wire from BB2 (NS) to V4 (NS).
- () Connect a wire from V4 (S) to V2 (NS).
- () Connect a bare wire from V2 (S) to V7 (S).
- () Connect a wire from B \blacktriangle (S) to BB1 (NS).
- () Connect a 10 K Ω 2 watt resistor (brown-black-orange) from BB1 (S) to BB3 (NS).
- () Connect a 15 K Ω resistor (brown-green-orange) from BB3 (NS) to V6 (S) (use sleeving).
- () Connect a wire from BB3 (S) to W4 (S).
- () Connect a wire from W1 (S) to BB2 (S).
- () Insert the threaded end of the BFO coil (#40-77) from the inside of the chassis at position S. Wide space at the other end of the coil form should be oriented so that it faces the speaker cutout on the end of the chassis.

NOTE: A small chassis hole is provided to accommodate the locating pin in the clip. It might be necessary to rotate the clip of the coil form so that the pin can engage the hole. Press against the open end of the coil form until clip has passed through the chassis and spring portion has expanded on the chassis top. Be careful not to damage or disturb the coil windings.

- () Connect a 150 $\mu\mu\text{f}$ mica capacitor from S3 (NS) to S1 (NS). Keep the leads short to avoid future movement of the capacitor.
- () Connect a bare wire from S1 (S) to C4 (S).
- () Connect a bare wire from S2 (S) to C2 (NS).
- () Connect a wire from C2 (S) to W2 (S). Run this wire against the chassis.
- () Connect a 33 $\mu\mu\text{f}$ ceramic capacitor between C1 (S) and S3 (S).
- () Mount the small antenna trimmer capacitor at Y using 4-40 screws and lockwashers. Position as shown. Bend lug 1 down toward solder lug FF so it touches the solder lug (NS). See Figure 7.
- () Mount the two gang bandspread capacitor at Z using 6-32 x 3/16 screws and lockwashers. Position as shown.
- () Solder short lengths of braid from each of the two solder lugs on the tuning capacitor mounting screws to the adjacent ground lugs on the chassis.

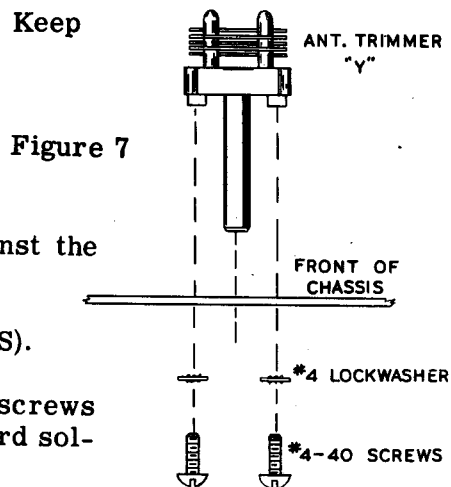

ASSEMBLY AND WIRING OF THE COIL BRACKET ASSEMBLY

- () Mount the AA coil (#40-69) in position AA as shown. Snap the coil in place, making sure the locating lug fits into the small hole provided. The colored dot below lug 1 should face the panel end (the longer end containing a 25/64" hole).
- () Mount coil BA (#40-70) in position BA as above.
- () Mount coil CA (#40-71) in position CA as above.
- () Mount the three trimmer capacitors in the three small holes between the two rows of coils. See Figure 8. These trimmer positions are lettered TA, TB and TC, corresponding to positions of adjacent coils.
- () Mount coil AC (#40-73) in position AO as above.
- () Mount coil BO (#40-74) in position BO as above.
- () Mount coil CO (#40-75) in position CO as above.

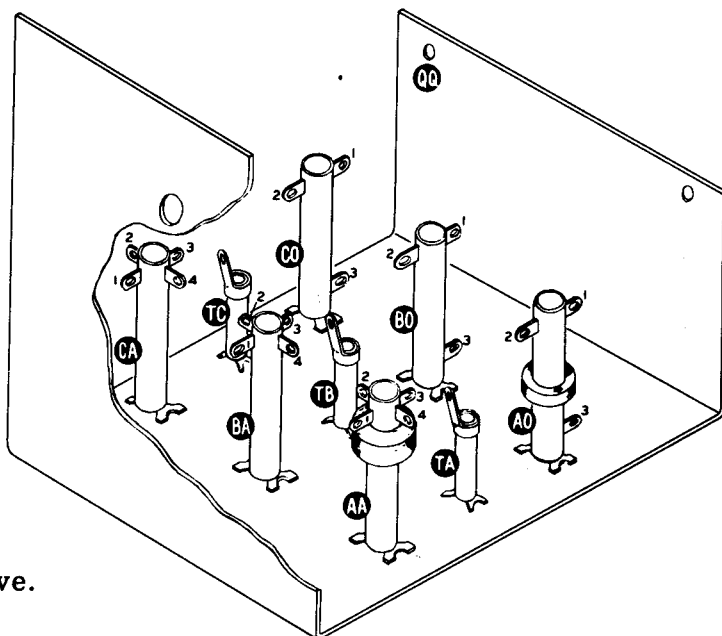

Figure 8

- () Solder each of the metal coil mounts and trimmer capacitor mounts to the coil bracket assembly. This is important to complete the ground side of the antenna and oscillator circuits. Only a small amount of solder will be necessary. Work slowly and do not use too much heat or the coil forms may be charred. Be sure the slugs in the trimmer capacitors are screwed fully into the plastic body before soldering, to prevent melting and deformation of the thin dielectric material, if plastic trimmers are supplied.

- () Insert a bare wire through lug 3 on coil CO, through lug 3 of coil BO to lug 3 coil AO. Leave 2 1/2" of wire extending beyond lug 3 on coil CO. Solder all three connections.
- () Connect a bare wire from TA (S) to AO2 (NS).
- () Connect a bare wire from TB (S) to BO2 (NS).
- () Connect a bare wire from TC (S) to CO2 (NS).
- () Run a bare wire through CA1 through BA1 to AA1, leaving 2" of wire extending beyond CA1. Solder AA1 and BA1.
- () Run a bare wire through AA3 through BA3 to CA3, leaving 2 1/4" of wire extending beyond AA3. Solder all three connections.
- () Cut one lead of a 350 $\mu\mu\text{f}$ mica capacitor (orange-green-brown) to 5/8". Connect to AO2 (S). Leave the other end free.
- () Cut one lead of a 910 $\mu\mu\text{f}$ mica capacitor (white-brown-brown) to 5/8". Connect to BO2 (S). Leave the other end free.
- () Cut one lead of a 2000 $\mu\mu\text{f}$ mica capacitor (red-black-red) to 5/8". Connect to CO2 (S). Leave the other end free. Use care when connecting the lead to the coil terminal to prevent breakage due to the heavier lead wire used.
- () Mount the bandswitch X as shown. Do not tighten securely as the nut will be removed later when mounting the coil and switch assembly in the receiver. See Figure 9.

NOTE: Contact lugs on the front face of the switch wafer nearest the panel are numbered XA1, XA2 etc. Contact lugs on the rear face of this wafer have XB numbers. Lugs on the rear wafer have XC and XD numbers. See Figure 9 for detailed numbering.

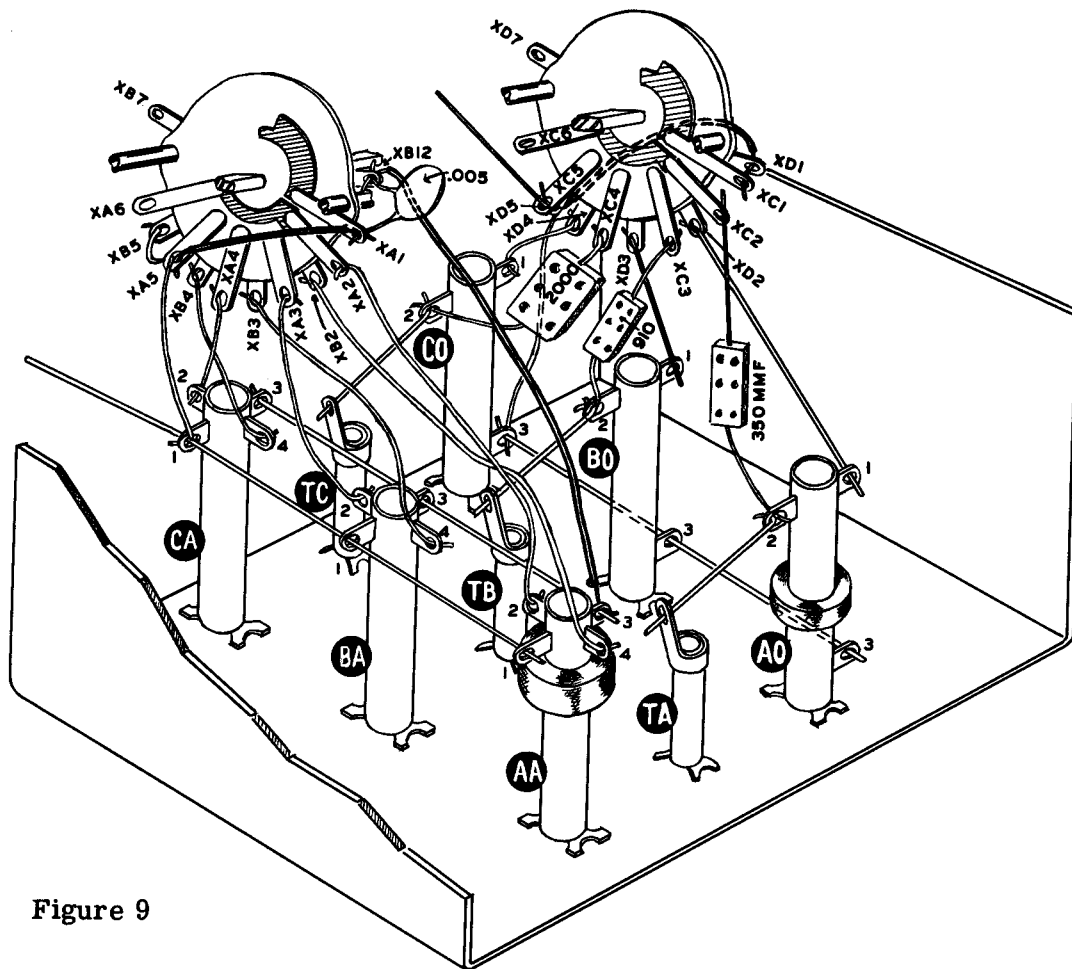

Figure 9

- () Connect the loose end of the 350 $\mu\mu\text{f}$ capacitor coming from AO2 to XC2 (S).
- () Connect the loose end of the 910 $\mu\mu\text{f}$ capacitor coming from BO2 to XC3 (S).
- () Connect the loose end of the 2000 $\mu\mu\text{f}$ capacitor coming from CO2 to XC4 (S).

- () Run a bare wire from AO1 (S) to XD2 (S).
- () Run a bare wire from BO1 (S) to XD3 (S).
- () Run a bare wire from CO1 (S) to XD4 (S).
- () Run a bare wire from AA2 (S) to XA2 (S).
- () Run a bare wire from BA2 (S) to XA3 (S).
- () Run a bare wire from CA2 (S) to XA4 (S).
- () Run a bare wire from XB2 (S) to AA4 (S).
- () Run a bare wire from XB3 (S) to BA4 (S).
- () Run a bare wire from XB4 (S) to CA4 (S).

- () Run a bare wire through double clip XC1-XD1 (S) to double clip XC5-XD5 (NS). Leave 2 1/2" of wire extending beyond XC5-XD5. Use sleeving on the wire between XC1-XD1 and XC5-XD5.

- () Connect wire coming from CO3 to XC5-XD5 (S).

- () Connect the bare wire coming from AA3 to XB12 (NS) (use sleeving).

- () Connect a bare wire from CA1 (S) through XA5 (NS) to XA1 (NS). Use sleeving between XA1 and XA5.

- () Connect a bare wire from XA5 (S) to XB5 (S).

- () Fasten one spade bolt to hole QQ on the coil shield as shown in Figure 10, using 6-32 x 3/16 screws, #6 lockwashers and nuts. Note that the spade bolt mounts from inside the coil shield.

- () Remove the nut holding the bandswitch to the coil bracket.

- () Insert the coil and switch assembly from the top of the chassis as shown in Figure 10, through the chassis cutout so that the bandswitch shaft goes through the hole in the front of the chassis.

- () The spade bolt on the rear of the coil bracket should fit through the small hole on top of the chassis behind the cutout and the rear section of the coil bracket should fit outside the spade bolt holding terminal strip CC.

- () Fasten the bandswitch to the chassis using a flat control washer and control nut.

- () Complete the assembly by fastening the spade bolt at RR to the coil bracket using 6-32 x 3/16 screw, #6 lockwasher and nut. Fasten the other spade bolt beneath the chassis using a #6 lockwasher and nut.

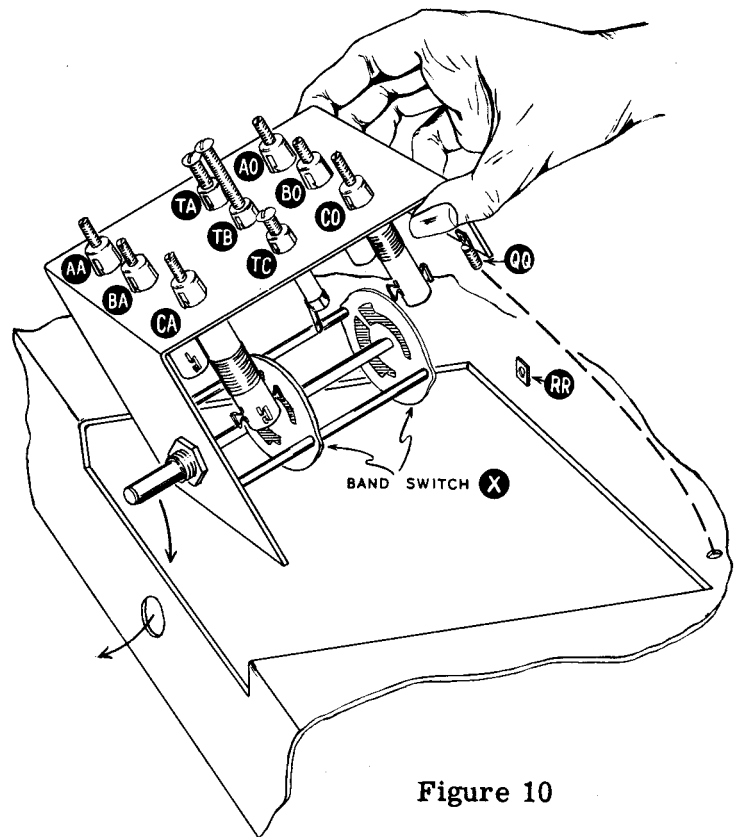
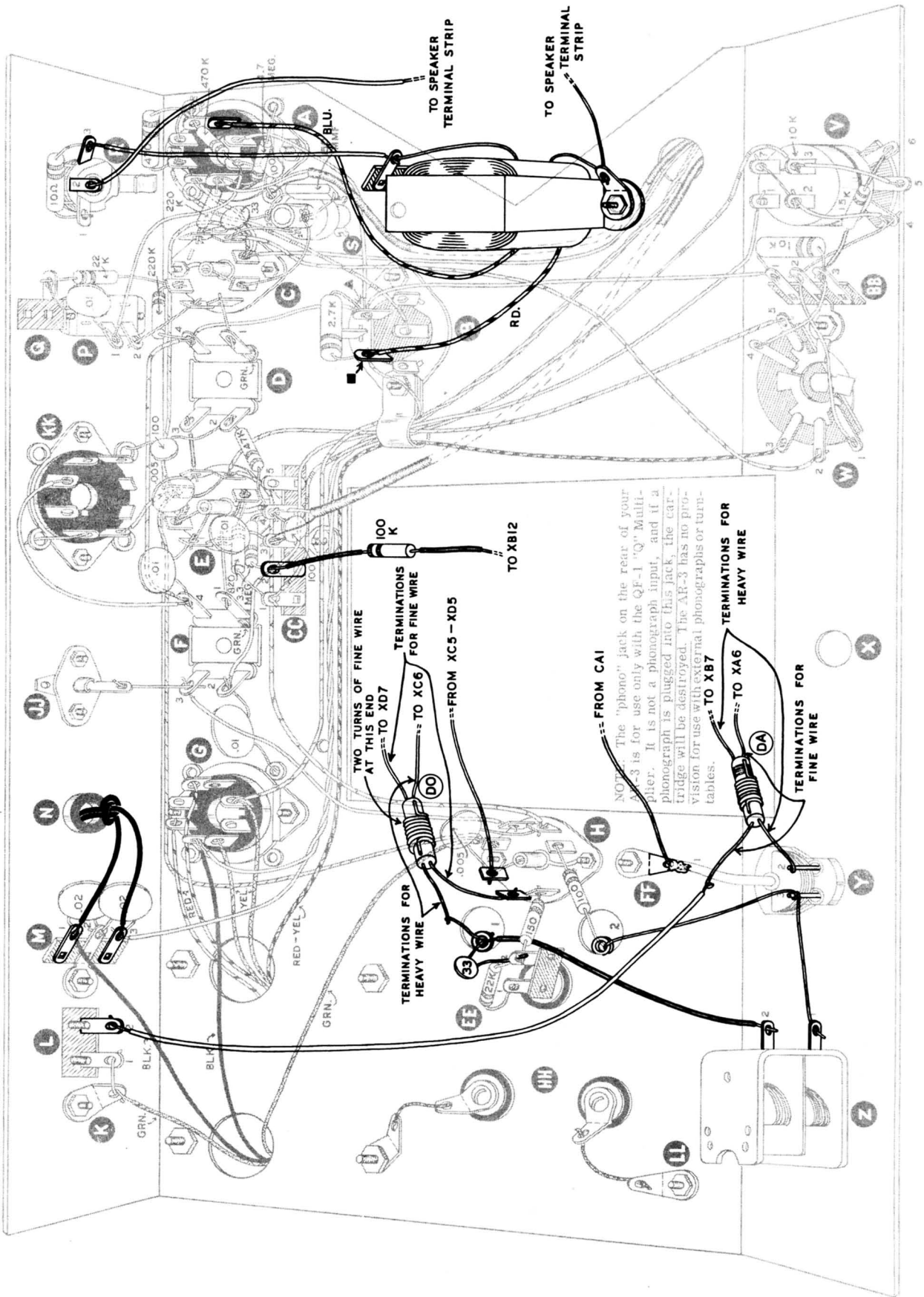

Figure 10



PICTORIAL 4

FINAL ASSEMBLY AND WIRING

- () Connect the bare wire coming from CA1 to solder lug FF (S). See Pictorial 4.
 - () Connect the bare wire coming from XC5-XD5 to H3 (S).
 - () Place sleeving on both leads of a 100K Ω (brown-black-yellow) resistor and connect between CC2 (S) and XB12 (NS).
 - () Connect a .005 μ fd ceramic capacitor between XB12 (S) and XA1 (S).
 - () Identify the DA coil (#40-72). This is the small coil with pigtail leads having one winding of heavy wire and a separate winding of fine wire wound on the form at the end of the heavy winding.
 - () Mount this coil as shown, with the small winding of fine wire at the end closest to the bandswitch X. Connect the long pigtail adjacent to the termination of the heavy winding at the end nearest the bandswitch to XB7 (S).
 - () Connect the other long pigtail at the same end to XA6 (S).
 - () At the opposite end of the coil, connect the long pigtail adjacent to the termination of the heavy winding to Y2 (S).
 - () Mount the remaining coil with pigtail leads as shown, with the fine wire winding (interwound between turns at one end of the heavy winding) adjacent to the bandswitch X.
 - () Connect the long pigtail adjacent to the termination of the heavy winding near the bandswitch to XC6 (S).
 - () Connect the other long pigtail at the same end to XD7 (S).
 - () At the other end of the coil, solder a bare wire to the long pigtail adjacent to the termination of the heavy winding, if necessary, and connect to lug HH1 (NS) of the main tuning capacitor. This is the terminal closest to the rear of the chassis.
 - () At the same end of the coil, extend the pigtail as above described if necessary and connect to H2 (S).
 - () Connect a bare wire through Z1 to Y3 and connect to lug HH2 of the main tuning capacitor. Solder all three connections.
 - () Connect a bare wire between Z2 (S) and HH1 (NS) (use sleeving). Run this wire as directly as possible between these two connections.
 - () Connect a 33 μ mf ceramic capacitor between EE2 (S) and HH1 (S). Use short leads.
 - () Connect an insulated wire between L2 (S) and the remaining pigtail (S) on DA coil (#40-72). Keep this lead as short as possible and connect directly between these two points.
- IMPORTANT:** Recheck installation of coils DA and DO, preferably by continuity tests with an ohmmeter.
1. Heavy wire winding of DA must be connected between bandswitch lug XB7 and antenna trimmer condenser lug Y2.
 2. Fine wire of DA between XA6 and L2.
 3. Heavy wire of DO between XC6 and HH1.
 4. Fine wire of DO between XD7 and H2.

DIAL PLATE ASSEMBLY

- () Slip the dial drum pulley over the shaft of the tuning condenser with the brass bushing inward. Tighten the bushing with a #8 set screw temporarily.

() Install the dial plate with the small pulleys inward. Use 6-32 x 3/4 screws and nuts with #6 lockwashers under the nuts. Use 3/8" spacers on the screws between the dial plate and the chassis. See Figure 11.

() Install the 500 KΩ volume control VC as shown, using a 3/8 lockwasher between the control and the back of the dial plate. Tighten it down with a 3/8 control nut.

() Note numbering of the terminals on the volume control and connect Spirashield pigtail to VC1 (S). This is the shielded lead that connects to terminal strip CC.

() Connect the inner conductor of that same Spirashield to VC3 (S).

() Connect either lead of the twisted pair to VC4 (S).

() Connect the other lead of the twisted pair to VC5 (S).

() Insert the 7/16" grommets in the holes in the dial plate at each end of the dial calibrations.

() Install #47 bulbs in each of the two pilot lamp sockets and insert the bulbs partly through each of the two grommets just installed from the rear side of the dial plate. Position the lugs as shown. See Figure 12.

() Connect the wire coming through the hole beneath the volume control VC to lug 1 on the pilot lamp SS (S).

() Connect a wire from SS2 (S) to TT1 (S).

() Connect a wire from TT2 (S) to the ground lug FF on top of the chassis near socket H (S).

() Mount the speaker and output transformer at position U as shown in Figure 13, using 6-32 hardware. The speaker is mounted above the chassis and the output transformer below. The red and blue wires on the output transformer should face the inside of the chassis and the two uninsulated wires face the speaker cutout. Mount a 1-lug terminal strip under the screw on top of the chassis holding the end of the speaker nearest the panel. Mount a solder lug under the nut on the same screw, beneath the chassis.

() Mount a 1-lug terminal strip on the other mounting screw beneath the chassis, using a #6 lockwasher and nut.

() Connect one of the uninsulated wires from the output transformer to the solder lug UU (NS).

() Connect a wire from UU (S) to the nearest voice coil terminal on the speaker (S).

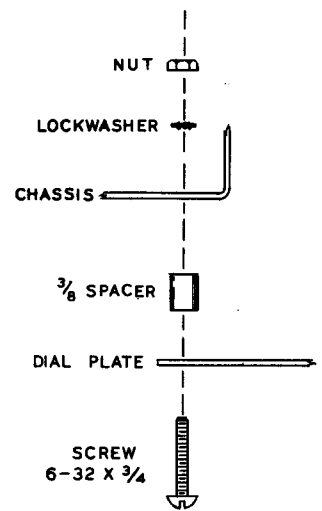

Figure 11

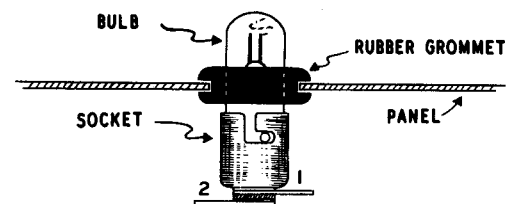

Figure 12 TOP VIEW

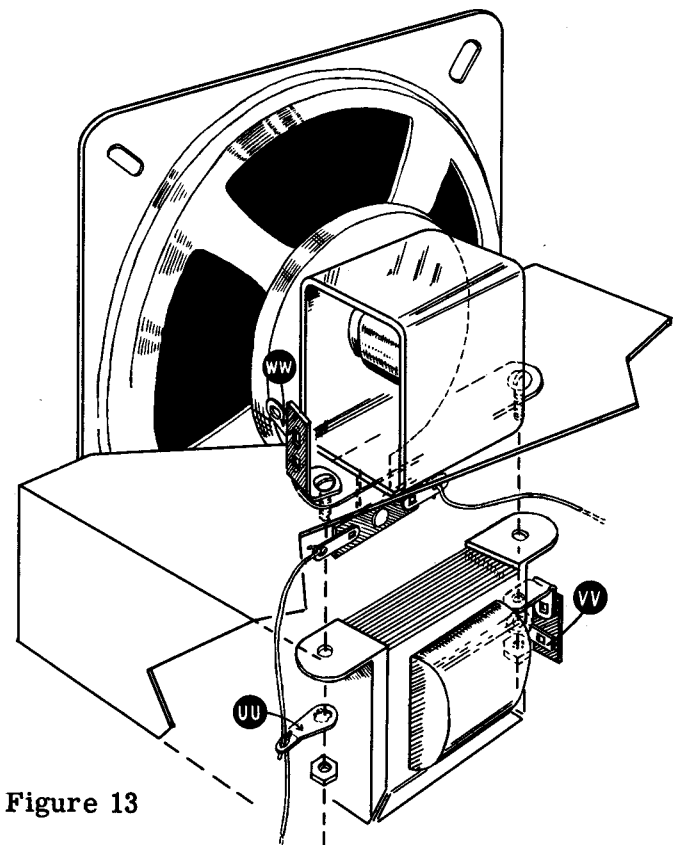

Figure 13

- () Connect the other uninsulated wire to VV (NS).
- () Connect a wire from VV (S) to R3 (S).
- () Connect a wire from R2 (S) to the remaining voice coil terminal on the speaker (S).
- () Connect the blue lead from the output transformer to A3 (S).
- () Connect the red lead to B ■ (S).
- () Turn the receiver over and connect the center lead in the Spirashield coming through the hole beneath the volume control VC to WW (NS).
- () Connect an .02 μ fd ceramic capacitor between WW (S) and VC2 (S) (use sleeving).

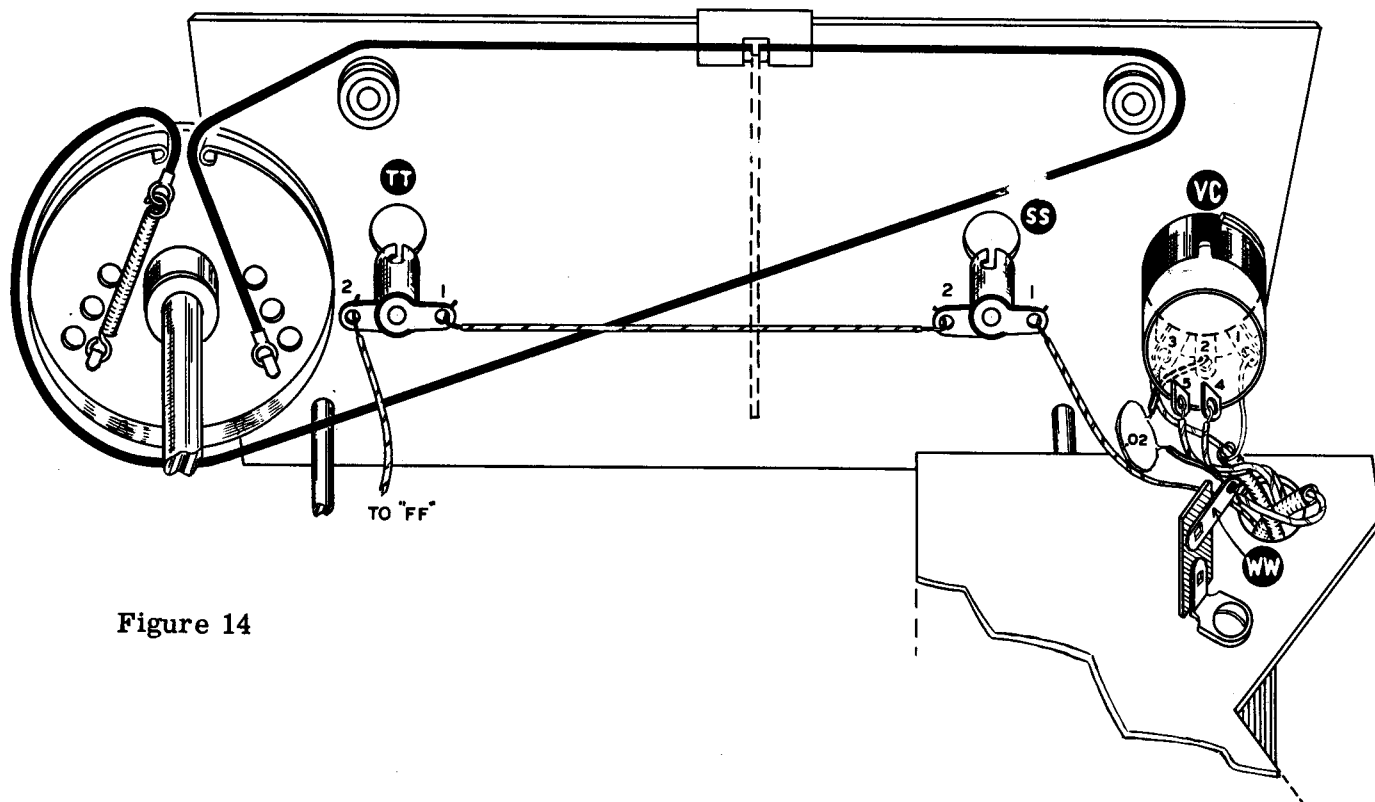

Figure 14

- () Readjust the dial drum pulley so that the opening in the outer rim is straight up when the tuning condenser is fully meshed. The spacing between the drum and the rear of the dial plate should be approximately 1/8". Tighten the set screw permanently.
- () String the dial cord as shown. It has been pre-cut to the proper length and no further adjustment is necessary. See Figure 14.
- () Mount one of the large black and chrome knobs on the shaft of the volume control VC and tighten.
- () Mount the other large knob on the main tuning capacitor shaft.
- () Mount the small black knob without a pointer on the shaft of the bandspread capacitor and tighten.
- () Mount the large black knob with the white line on the bandswitch shaft. Position the knob so that the line points correctly at each of the switch positions.

- () The three remaining knobs have pointers. They should be mounted on the three remaining shafts. If the receiver is mounted in the Heathkit cabinet, or if another cabinet and the control plate are used, the pointers should coincide with the markings on the panel or control plate. The plastic pointer should be used on the bandspread capacitor shaft whenever the cabinet or control plate is used, to indicate the position of the bandspread control.
 - () With the tuning capacitor fully meshed, install the dial pointer as shown. It should coincide with the vertical line connecting the dial scales on the left side, before crimping the ears on the pointer to the dial cord. Do not use too much pressure or the ears may cut the dial cord.
 - () Turn the receiver over and insert the end of the line cord through grommet N at the rear of the chassis. Tie a knot 2 1/2" from the end. Connect one lead of the line cord to M1 (S) and the other lead to M3 (S).
 - () Insert the tubes in the proper sockets, making sure they are properly seated.
 - () Mount the four angle brackets as shown in Figure 15, using 6-32 x 3/16 screws, lockwashers and nuts.
 - () Cut the labels apart and strip the adhesive from the back. Press firmly in place in the proper positions on the rear chassis apron.
- This completes the construction of your Heathkit model AR-3 Receiver.

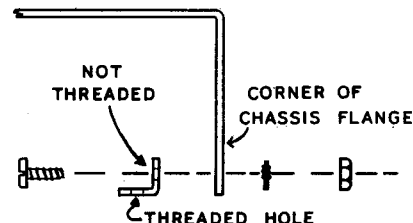

Figure 15

RECEIVER ALIGNMENT

The following procedure is commonly used in the service industry even though many other methods may be used. It is assumed that a DC meter of some type is available in addition to an RF signal generator capable of producing an unmodulated signal at frequencies from 455 kc through 30 mc. The Heathkit model SG-8, used with model V-7 VTVM or a 20,000 Ω per volt multimeter would be ideal. If the proper meter cannot be obtained, you may align the set by ear. In that case, a modulated RF signal is necessary and this also is produced by model SG-8. Whenever an adjustment point of maximum meter indication is mentioned in the procedure, you may adjust to maximum volume if a speaker is used. Use an insulated alignment tool in order to eliminate the capacitive effect of the hand, which will cause a false point of adjustment in all cases. For convenience, we will refer to the meter as a VTVM used as a DC voltmeter.

Return all controls and switches to the positions indicated above the voltage chart on Page 24. Make a temporary connection between terminal HH1 on the tuning condenser and the chassis. Connect the common VTVM lead to the chassis and the DC test lead to terminal VC3 on the volume control. Connect the hot lead of a signal generator, through a .01 μ fd condenser, to terminal 7 on socket H and the ground lead to the receiver chassis. Set the VTVM selector switch to DC-, since the voltage will be negative, and the range switch to one of the high positions. Plug the receiver in and turn the volume control fully clockwise. Set the signal generator to 455 kc, unmodulated and reduce the output until a readable voltage is obtained on the lowest VTVM range.

Adjust the bottom screw on the output IF transformer for maximum meter indications. Then adjust the top screw to maximum. Reduce the signal output of the generator as the VTVM readings become higher. Now adjust the top screw on the input IF transformer to maximum. Finally the bottom screw is adjusted. Repeat the procedure at least twice since there may be a tendency for the transformers to interact. This completes the alignment of the IF transformers.

Remove the temporary connection between HH1 and the chassis. Rotate the bandspread condenser so it is fully meshed. Do not touch the bandspread condenser after this adjustment. Turn the bandswitch to "D" which is fully clockwise. Also tune the receiver to 30 mc. Connect the ground lead of the signal generator to the chassis or to the grounded screw head on the antenna terminal strip. The hot lead is then connected to the antenna screw through a resistor of about 470 Ω which will act as a dummy antenna.

Set the ANTENNA TRIMMER to about 50% meshed. Set the generator to 30 mc and adjust the band "D" oscillator trimmer for maximum meter deflection. The oscillator trimmer for this band is located at the base of the rear section of the tuning condenser. The adjustment will be critical and the meter indication may change when the tool is removed from the screw head.

Maximum reading should be present after the tool is removed. There will always be a residual reading due to the presence of a constant AVC voltage.

Adjust the band "D" antenna trimmer until maximum meter indication occurs exactly at 30 mc on the dial plate. This trimmer is located at the base of the front section of the tuning condenser.

Check the image frequency by setting the generator to 30.910 mc, which is twice the IF frequency above 30 mc. If the image appears at 910 kc below 30 mc rather than above, then it will be necessary to unscrew the band "D" oscillator trimmer until these two maximum points are properly positioned. They should occur at 30 mc and again at 30.910 mc.

Turn the bandswitch to band "C" and tune the receiver to 4 mc. Set the signal generator to 4 mc and adjust the band "C" oscillator coil slug for maximum indication on the meter. Now adjust the band "C" antenna coil slug for maximum indication on the meter.

Turn the generator to 10 mc and tune the receiver to the same frequency. Adjust the band "C" oscillator trimmer capacitor for maximum indication on the meter. Return the receiver and generator to 4 mc and touch up the band "C" oscillator coil slug again for maximum indication.

Turn the bandswitch to band "B" and tune the receiver to 1.5 mc. Tune the generator to the same frequency. Adjust the band "B" oscillator coil slug for maximum indication on the meter. Also adjust the band "B" antenna coil slug for maximum indication. Tune both the receiver and generator to 4 mc. Adjust the band "B" oscillator trimmer for maximum indication. Repeat the adjustment of the oscillator coil slug again at 1.5 mc.

Turn the bandswitch to band "A" and tune the receiver and generator to .55 mc (550 kilocycles). Adjust the band "A" oscillator coil slug for maximum indication on the meter. Now adjust the band "A" antenna coil slug for maximum indication. Tune both the receiver and generator to 1.5 mc (1500 kilocycles) and adjust the band "A" oscillator trimmer for maximum indication. Repeat the oscillator coil slug adjustment at 550 kilocycles.

When tuning the receiver, the image will always fall below the signal frequency. This completes the alignment of your Heathkit model AR-3 Receiver.

BFO ADJUSTMENT

Turn the PHONE-STANDBY-CW switch to the CW position. Reduce RF gain and advance volume. Tune in a steady carrier signal on any band and adjust the BFO coil slug. A point will be found where a high-pitched whistle is heard, gradually descending in pitch until a point of no signal is reached (called "zero-beat") after which the signal will again appear and increase in pitch until it disappears. On either side of the zero-beat point just described, will be found a point where the pitch of the signal is most pleasing to the ear. This is the point to which the BFO coil slug should be adjusted. When using the receiver for CW reception, always tune for the same pitch signal, since this centers the incoming signal in the IF passband.

The signal generator, supplying an unmodulated signal may be used in adjusting the BFO and in many cases, it will be simpler to do so, since the effect of fading will be eliminated.

IN CASE OF DIFFICULTY

1. Recheck the wiring. Trace each lead in colored pencil on the pictorial as it is followed in the receiver. Most cases of difficulty result from wrong connections. (Often having a friend check the wiring will reveal a mistake consistently overlooked.)

2. Compare the socket voltages with those shown in the table. The readings should be within 20% of those tabulated if a VTVM is used. Other types of meters may give lower readings. If a voltage reading fails to compare with the value shown, check further into the circuit involved by checking the various components (resistors, condensers, tubes, etc.).

Set controls as follows:

Tuning condenser fully meshed.
 Bandswitch in position "A".
 RF gain control clockwise with AVC on.
 No connection to antenna terminal.

Bandspread condenser fully meshed.
 Selector switch in phone position.
 Volume control at minimum with switch on.

SOCKET TUBE TYPE	Pin 1	Pin 2	Pin 3	Pin 4	Pin 5	Pin 6	Pin 7	Pin 8
H 12BE6	-5.5	0	0	Fil.	+215	+88	NS	
E 12BA6	NS	0	0	Fil.	+215	+88	+2.6	
C 12AV6	NS	0	Fil.	0	NS	NS	+88	
A 12V6	0	0	+250	+205	NS	TP	Fil.	+10.6
G 5Y3GT	0	+260	TP	245AC	0	245AC	0	+260

NS - not significant.

TP - tie point.

Fil. - voltage between terminals so marked and ground is approximately 12 volts AC.

All voltages are DC measured to chassis unless otherwise stated. All readings taken with a Heathkit model V-7 VTVM.

3. If socket voltages are within 20% of the values indicated and trouble still persists, remove all tubes and have them checked by a competent radio serviceman.
4. Carefully recheck the color codes on resistors, condensers and transformer leads. If there is a question concerning the color of a transformer lead, scraping the insulation lightly with a knife may help to identify the color quickly.

Most difficulties fall in a general pattern and the following outline will be helpful in isolating the causes:

COMPLETELY DEAD RECEIVER: The cause will usually be found in the power supply section. The voltage between the line cord terminations, M1 and M3 should check 110 to 120 volts AC. If the ON-OFF switch is operating properly, this same voltage will be present between M1 and G3 with the switch on. Incorrect voltages at socket G may be caused by a faulty 5Y3 tube or by wrong connections at that socket. It can also be caused by excessive current drain in another portion of the circuit. The DC voltage at G8 should also be present at lug ■ of the filter condenser. Lug ▲ on the filter condenser should be lower in voltage than ■. The plate and screen voltages at sockets A, H, C and E should then compare with the chart. If not, check the IF transformer wiring and all resistors connected either directly or indirectly to plate and screen grid terminals. If any of these voltage points read zero, then an open circuit is present between it and the B+ supply circuit.

NOISE AND HUM, BUT NO SIGNAL: Signal loss can be caused by incorrect wiring or faulty tubes. The stage causing the trouble can be isolated by touching a screwdriver with an insulated handle to each control grid terminal in the signal circuit beginning with socket A, the C, E and H in that order. Place the screwdriver on terminal A5 and then touch your finger to the metal portion of the screwdriver, being careful not to touch any other part of the receiver or chassis with either hand. A low pitched hum should be audible. Then proceed to C5 and the hum should be much louder. At terminals E1 and H7, the hum and noise level should both increase greatly. The absence of hum at A5 will indicate a faulty 12V6 tube in most cases. It is assumed that the wiring is correct. No hum increase at C5 indicates a bad 12AV6 tube, a faulty .01 μ fd coupling condenser, incorrect wiring at that socket or a short between C5 and ground. No increase of signal at E1 can be caused by a faulty 12BA6 tube or the output IF transformer. A short between E1 and ground can also be the cause. The input IF transformer, the 12BE6 tube and the wiring at socket H will be suspected if the noise and hum level do not increase when touching H7.

If no great increase in the noise level is noticed when touching the antenna terminal, check continuity through the antenna and oscillator coil for that band. The two coils under the chassis should also be checked in addition to the wiring of the bandswitch and coil turret. Look for a short between the plates of the tuning and bandspread condensers.

DISTORTION: A careful voltage check will usually reveal the cause of distortion. High values of resistance at E7 may be the trouble and therefore these particular resistors should be checked. By isolating and correcting the cause of any serious voltage difference, distortion will usually be eliminated. If several volts are measured between A5 and A1, the output stage is probably oscillating. Redress the leads at socket A and also the output transformer leads. Check the position of the NOISE LIMITER switch. The noise limiter will usually cause a certain amount of distortion on a phone signal, particularly music or singing. The noise limiter should remain off until needed.

SQUEALING AND HOWLING: Check the connections to both Spirashields and the conductors inside the shields. Also check the lead dress and wiring along terminal strip CC and to the volume control. Using the receiver in close proximity to an operating TV receiver will also cause this type of disturbance since every TV receiver is an effective "transmitter" of interference.

HUM: An open section of the filter condenser B will cause a high hum level at 120 cycles. A 60 cycle hum can be caused by leakage between elements in one of the tubes. In this case, the best testing method is to replace the tube temporarily for comparison purposes. Hum can also be caused by operating the receiver in a strong electrostatic field. Additional shielding will be helpful in that respect.

The correct placement of parts, correct wiring and proper identification of components cannot be over-emphasized since an error can cause many types of trouble. The model AR-3 is practically trouble-free and if a mistake is made, the result will no doubt fall into one of the categories listed above.

OPERATION

PHONE OPERATION: Turn the SELECTOR switch to PHONE position, advance the RF gain control fully clockwise until a click is heard. This activates the AVC circuits, eliminating much fading and blasting when tuning across phone signals of varying strength. Advance the volume control for sufficient volume and rotate the main tuning control to the approximate frequency of the phone station desired, making sure the bandswitch is in the proper position. Tune with the bandspread capacitor until the desired station is centered in the receiver passband. This is easily recognized as the point of no, or least, distortion. Peak the signal using the antenna trimmer and adjust the volume control to the level desired.

CW OPERATION: Turn the SELECTOR switch to CW, advance the volume control fully clockwise and reduce the RF gain, removing AVC and allowing manual control of the sensitivity and therefore, the gain of the receiver. Set the bandswitch to the proper band and tune the main tuning to the approximate frequency desired. Tune in the signal with the bandspread capacitor and peak it with the antenna trimmer. Adjust the volume level using the RF gain control.

STANDBY: Turning the **SELECTOR** switch to standby removes operating voltage from the receiver plates and screens but maintains the heaters at the proper operating temperature to prevent drift and to enable instant operation when the switch is returned to either **CW** or phone position. This switch does not turn the receiver off and should not be used as such. It is primarily used when the receiver is operated in conjunction with an amateur transmitter, while the transmitter is on the air.

BROADCAST BAND: It will be noted that the antenna trimmer capacitor has little effect on the reception of stations on band "A". This is normal. Also, all tuning on this band should be done with the main tuning control, as the bandspread control has limited tuning range, it is seldom, if ever used on this band.

NOTE: The bandspread tuning control should be set to its closed (fully meshed) position (0 on the bandspread dial) when tuning with the main tuning control, in order that the frequency to which the receiver is tuned will coincide with the calibration markings on the main tuning dial.

NOISE LIMITER: Interference to reception on the higher frequency bands can be caused by such sources as automobile ignition, electric signs, signalling devices, etc. This type of interference will be recognized by sharp clicking or buzzing sounds. The **NOISE LIMITER** circuit will be found highly useful in eliminating or materially reducing this type of interference. To place it in operation, simply place the slide switch on the rear of the chassis in the **ON** position. Slight distortion of the audio signal may be noted while using the noise limiter. This is normal and for this reason it is desirable to leave the noise limiter turned off except during periods of such interference. The noise limiter will be found to be more effective on **AM** signals than **CW**. This should be kept in mind when difficulty is experienced during **CW** reception.

REPLACEMENTS

Material supplied with Heathkits has been carefully selected to meet design requirements and ordinarily will fulfill its function without difficulty. Occasionally improper instrument operation can be traced to a faulty tube or component. Should inspection reveal the necessity for replacement, write to the Heath Company and supply all of the following information:

- A. Thoroughly identify the part in question by using the part number and description found in the manual parts list.
- B. Identify the type and model number of kit in which it is used.
- C. Mention the order number and date of purchase.
- D. Describe the nature of defect or reason for requesting replacement.

The Heath Company will promptly supply the necessary replacement. Please do not return the original component until specifically requested to do so. Do not dismantle the component in question as this will void the guarantee. If tubes are to be returned, pack them carefully to prevent breakage in shipment as broken tubes are not eligible for replacement. This replacement policy does not cover the free replacement of parts that may have been broken or damaged through carelessness on the part of the kit builder.

SERVICE

In event continued operational difficulties of the completed instrument are experienced, the facilities of the Heath Company Service Department are at your disposal. Your instrument may be returned for inspection and repair for a service charge of \$5.00 plus the cost of any additional material that may be required. **THIS SERVICE POLICY APPLIES ONLY TO COMPLETED INSTRUMENTS CONSTRUCTED IN ACCORDANCE WITH THE INSTRUCTIONS AS STATED IN THE MANUAL.** Instruments that are not entirely completed or instruments that are modified in design will not be accepted for repair. Instruments showing evidence of acid core solder or paste fluxes will be returned not repaired.

The Heath Company is willing to offer its full cooperation to assist you in obtaining the specified performance level in your instrument. Factory repair service is available for a period of one year from the date of purchase or you may contact the Engineering Consultation Department by mail. For information regarding possible modification of existing kits, it is suggested that you refer to any one or more of the many publications that are available on all phases of electronics. They can be obtained at or through your local library, as well as at any electronic outlet store. Although the Heath Company sincerely welcomes all comments and suggestions, it would be impossible to design, test, evaluate and assume responsibility for proposed circuit changes for specific purposes. Therefore, such modifications must be made at the discretion of the kit builder according to information which will be much more readily available from some local source.

SHIPPING INSTRUCTIONS

Before returning a unit for service, be sure that all parts are securely mounted.

**ATTACH A TAG TO THE INSTRUMENT GIVING
NAME, ADDRESS AND TROUBLE EXPERIENCED.**

Pack in a rugged container, preferably wood, using at least three inches of shredded newspaper or excelsior on all sides. **DO NOT SHIP IN THE ORIGINAL KIT CARTON AS THIS CARTON IS NOT CONSIDERED ADEQUATE FOR SAFE SHIPMENT OF THE COMPLETED INSTRUMENT.** Ship by prepaid express if possible. Return shipment will be made by express collect. Note that a carrier cannot be held liable for damage in transit if packing, in HIS OPINION, is insufficient.

SPECIFICATIONS

All prices are subject to change without notice. The Heath Company reserves the right to discontinue instruments and to change specifications at any time without incurring any obligation to incorporate new features in instruments previously sold.

WARRANTY

The Heath Company limits its warranty of parts supplied with any kit to a period of three (3) months from the date of purchase. Replacement will be made only when said part is returned postpaid, with prior permission and in the judgment of the Heath Company was defective at the time of sale. This warranty does not extend to any Heathkits which have been subjected to misuse, neglect, accident and improper installation or applications. Material supplied with a kit shall not be considered as defective, even though not in exact accordance with specifications, if it substantially fulfills performance requirements. This warranty is not transferable and applies only to the original purchaser. This warranty is in lieu of all other warranties and the Heath Company neither assumes nor authorizes any other person to assume for them any other liability in connection with the sale of Heathkits.

The assembler is urged to follow the instructions exactly as provided. The Heath Company assumes no responsibility or liability for any damages or injuries sustained in the assembly of the device or in the operation of the completed instrument.

HEATH COMPANY
Benton Harbor, Michigan

MOUNTING YOUR AR-3 RECEIVER IN CABINET 91-15A

Remove all knobs from the receiver. Note that there are four small and one large hole through the bottom of the cabinet. If these holes are not punched through the fabric cover of the cabinet, do so now using a pocket knife with a small blade, removing the excess fabric covering all holes. Be sure the bandspread capacitor is 50% meshed. Insert the receiver into the cabinet from the rear, allowing the shafts to protrude through the matching holes in the panel. Insert the four 6-32 x 3/8" screws through the bottom of the cabinet, engaging them in the mounting feet on the receiver chassis. Install the plastic pointer (Part #100-M31) over the bandspread shaft with the brass bushing through the panel. Position the hairline on the plastic pointer at 50 on the bandspread dial. Tighten the set screw in the bushing by inserting the screwdriver through the large hole in the bottom of the cabinet. Install all knobs on the receiver. This completes the installation of the receiver in the cabinet.

PART No.	PARTS Per Kit	DESCRIPTION	PART No.	PARTS Per Kit	DESCRIPTION
Resistors			Sockets-Terminal Strips-Jacks		
1-3	1	100 Ω 1/2 watt	431-6	1	2-lug antenna connector
1-8	1	820 Ω 1/2 watt	431-10	2	3-lug terminal strip
1-21	1	15 K Ω 1/2 watt	431-11	1	5-lug terminal strip
1-22	2	22 K Ω 1/2 watt	431-14	1	2-lug terminal strip
1-25	1	47 K Ω 1/2 watt	431-15	3	1-lug terminal strip
1-26	1	100 K Ω 1/2 watt	434-2	3	Octal socket
1-29	2	220 K Ω 1/2 watt	434-21	2	Pilot lamp socket
1-33	1	470 K Ω 1/2 watt	434-37	3	7-pin miniature socket
1-38	1	3.3 megohm 1/2 watt	434-42	1	Phono jack
1-66	1	150 Ω 1/2 watt	436-4	1	Phone jack
1-71	1	4.7 megohm 1/2 watt	Wire-Shielding		
1-1A	1	470 Ω 1 watt	340-2	1	length Bare wire
1-11A	1	10 Ω 1 watt	344-1	1	length Hookup wire
1-1B	1	2.7 K Ω 2 watt	345-2	1	length Copper braid
1-3B	1	10 K Ω 2 watt	346-1	1	length Sleeving
Capacitors			206-6	1	length Spirashield
20-34	1	350 μ f mica	89-1	1	Line cord
20-35	1	910 μ f mica	Sheet Metal Parts		
20-56	1	150 μ f mica	100-M76F116	1	Dial plate
20-57	1	2000 μ f mica	200-M93	1	Chassis
21-7	2	33 μ f ceramic	204-M93	1	Coil bracket
21-9	3	100 μ f ceramic	205-M48F115	1	Control plate
21-16	4	.01 μ f ceramic	Hardware		
21-27	3	.005 μ f ceramic	73-1	1	3/8" grommet
21-31	3	.02 μ f ceramic	73-3	2	7/16" grommet
25-6	1	20-20-20 μ f electrolytic	73-6	3	7/16" soft rubber grommet
26-15	1	Tuning capacitor	204-9	4	Angle bracket
26-16	1	Bandsread capacitor	250-2	6	3-48 screw
26-29	1	Antenna trimmer capacitor	250-7	9	6-32 x 3/16" screw
31-8	3	1-10 μ f trimmer capacitor	250-9	23	6-32 x 3/16" screw
Controls-Switches-Knobs			250-10	4	6-32 x 1/2" screw
19-16	1	10 K Ω w/switch	250-18	4	8-32 x 3/8" screw
19-28	1	500 K Ω w/switch	250-29	2	6-32 x 3/4" screw
60-1	1	SPST slide switch NOISE LIM.	250-43	2	8-32 x 1/4" set screw
63-109	1	Rotary switch SELECTOR	250-52	2	4-40 x 1/4" screw
63-110	1	Rotary switch BANDSWITCH	251-1	2	6-32 spade bolt
462-13	1	Knob, black	252-1	6	3-48 nut
462-14	2	Knob, black-chrome	252-3	29	6-32 nut
462-17	3	Knob, black w/pointer	252-4	4	8-32 nut
462-24	1	Knob, black w/white line	252-7	5	3/8" control nut
Transformers-Coils			253-10	5	3/8" control flat washer
40-69	1	Antenna coil, Band A	253-21	10	9/16" flat washer
40-70	1	Antenna coil, Band B	254-1	29	#6 lockwasher
40-71	1	Antenna coil, Band C	254-2	3	#8 lockwasher
40-72	1	Antenna coil, Band D	254-4	5	3/8" control lockwasher
40-73	1	Oscillator coil, Band A	254-9	2	#4 lockwasher
40-74	1	Oscillator coil, Band B	255-1	3	1/8" spacer
40-75	1	Oscillator coil, Band C	255-3	2	3/8" #6 spacer
40-76	1	Oscillator coil, Band D	259-1	7	#6 solder lug
40-77	1	BFO coil, 455 kc	259-2	1	#8 solder lug
51-3	1	Output transformer	Miscellaneous		
52-7	2	IF transformer, 455 kc	100-M31	1	Plastic pointer
54-36	1	Power transformer	207-4	1	Cable clamp
Tubes-Lamps			258-4	1	Spring, dial cord
411-3	1	5Y3GT tube	100-M27	1	Dial cord
411-104	1	12V6GT tube	260-7	2	IF mounting clip
411-50	1	12BE6 tube	390-22	1	Label, adhesive backing
411-51	1	12BA6 tube	401-9	1	Loudspeaker
411-52	1	12AV6 tube	463-1	1	Dial pointer
412-1	2	#47 pilot lamp	481-2	1	Capacitor mounting wafer
			100-M25	1	Dial pulley
			595-115	1	Instruction manual

HELPFUL KIT BUILDING INFORMATION

Before attempting actual kit construction read the construction manual through thoroughly to familiarize yourself with the general procedure. Note the relative location of pictorials and pictorial inserts in respect to the progress of the assembly procedure outlined.

This information is offered primarily for the convenience of novice kit builders and will be of definite assistance to those lacking thorough knowledge of good construction practices. Even the advanced electronics enthusiast may benefit by a brief review of this material before proceeding with kit construction. In the majority of cases, failure to observe basic instruction fundamentals is responsible for inability to obtain desired level of performance.

RECOMMENDED TOOLS

The successful construction of Heathkits does not require the use of specialized equipment and only basic tools are required. A good quality electric soldering iron is essential. The preferred size would be a 100 watt iron with a small tip. The use of long nose pliers and diagonal or side cutting pliers is recommended. A small screw driver will prove adequate and several additional assorted screw drivers will be helpful. Be sure to obtain a good supply of rosin core type radio solder. Never use separate fluxes, paste or acid solder in electronic work.

ASSEMBLY

In the actual mechanical assembly of components to the chassis and panel, it is important that the procedure shown in the manual be carefully followed. Make sure that tube sockets are properly mounted in respect to keyway or pin numbering location. The same applies to transformer mountings so that the correct transformer color coded wires will be available at the proper chassis opening.

Make it a standard practice to use lock washers under all 6-32 and 8-32 nuts. The only exception being in the use of solder lugs—the necessary locking feature is already incorporated in the design of the solder lugs. A control lock washer should always be used between the control and the chassis to prevent undesirable rotation in the panel. To improve instrument appearance and to prevent possible panel marring use a control flat nickel washer under each control nut.

When installing binding posts that require the use of fiber insulating washers, it is good practice to slip the shoulder washer over the binding post mounting stud before installing the mounting stud in the panel hole provided. Next, install a flat fiber washer and a solder lug under the mounting nut. Be sure that the shoulder washer is properly centered in the panel to prevent possible shorting of the binding post.

WIRING

When following wiring procedure make the leads as short and direct as possible. In filament wiring requiring the use of a twisted pair of wires allow sufficient slack in the wiring that will permit the twisted pair to be pushed against the chassis as closely as possible thereby affording relative isolation from adjacent parts and wiring.

















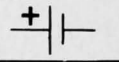

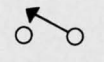
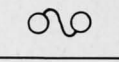

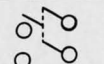
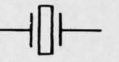
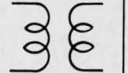
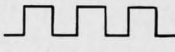
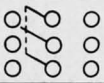
When removing insulation from the end of hookup wire, it is seldom necessary to expose more than a quarter inch of the wire. Excessive insulation removal may cause a short circuit condition in respect to nearby wiring or terminals. In some instances, transformer leads of solid copper will have a brown baked enamel coating. After the transformer leads have been trimmed to a suitable length, it is necessary to scrape the enamel coating in order to expose the bright copper wire before making a terminal or soldered connection.

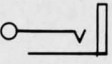
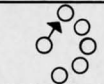
In mounting parts such as resistors or condensers, trim off all excess lead lengths so that the parts may be installed in a direct point-to-point manner. When necessary use spaghetti or insulated sleeving over exposed wires that might short to nearby wiring.

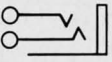
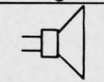
It is urgently recommended that the wiring dress and parts layout as shown in the construction manual be faithfully followed. In every instance, the desirability of this arrangement was carefully determined through the construction of a series of laboratory models.

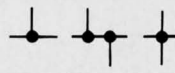
SOLDERING

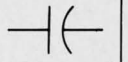
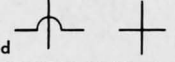
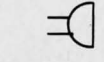
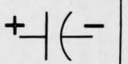
Much of the performance of the kit instrument, particularly in respect to accuracy and stability, depends upon the degree of workmanship used in making soldered connections. Proper soldered connections are not at all difficult to make but it would be advisable to observe a few precautions. First of all before a connection is to be soldered, the connection itself should be clean and mechanically strong. Do not depend on solder alone to hold a connection together. The tip of the soldering iron should be bright, clean and free of excess solder. Use enough heat to thoroughly flow the solder smoothly into the joint. Avoid excessive use of solder and do not allow a flux flooding condition to occur which could conceivably cause a leakage path between adjacent terminals on switch assemblies and tube sockets. This is particularly important in instruments such as the VTVM, oscilloscope and generator kits. Excessive heat will also burn or damage the insulating material used in the manufacture of switch assemblies. Be sure to use only good quality rosin core radio type solder.

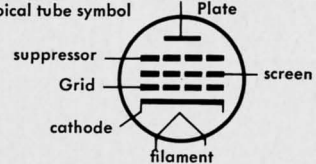
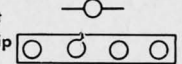
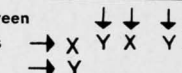
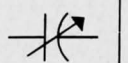
Antenna General		Resistor General		Neon Bulb		Receptacle two-conductor	
Loop		Resistor Tapped		Illuminating Lamp		Battery	
Ground		Resistor Variable		Switch Single pole Single throw		Fuse	
Inductor General		Potentiometer		Switch double pole single throw		Piezoelectric Crystal	
Air core Transformer General		Thermistor		Switch Triple pole Double throw		1000 =	K
Adjustable Powdered Iron Core		Jack two conductor		Switch Multipoint or Rotary		1,000,000 =	M
Magnetic Core Variable Coupling		Jack three conductor		Speaker		OHM =	Ω
Iron Core Transformer		Wires connected		Rectifier		Microfarad =	MF
Capacitor General		Wires Crossing but not connected		Microphone		Micro Microfarad =	MMF
Capacitor Electrolytic		A. Ammeter V. Voltmeter		Typical tube symbol 	Binding post Terminal strip 	Wiring between like letters is understood 	
Capacitor Variable		G. Galvanometer MA. Milliammeter uA. Microammeter, etc.					

HEATH COMPANY

A Subsidiary of Daystrom Inc.

THE WORLD'S FINEST ELECTRONIC EQUIPMENT IN KIT FORM

BENTON HARBOR, MICHIGAN