

PRICE \$3.00

HEATH COMPANY · BENTON HARBOR, MICHIGAN

HEATHKIT[®] ASSEMBLY MANUAL



HEATHKIT[™] by DAYSTROM



HIGH FIDELTY 14 WATT
STEREO AMPLIFIER

MODEL SA-2

ASSEMBLY AND OPERATION OF THE HEATHKIT HIGH FIDELITY 14 WATT STEREO AMPLIFIER MODEL SA-2

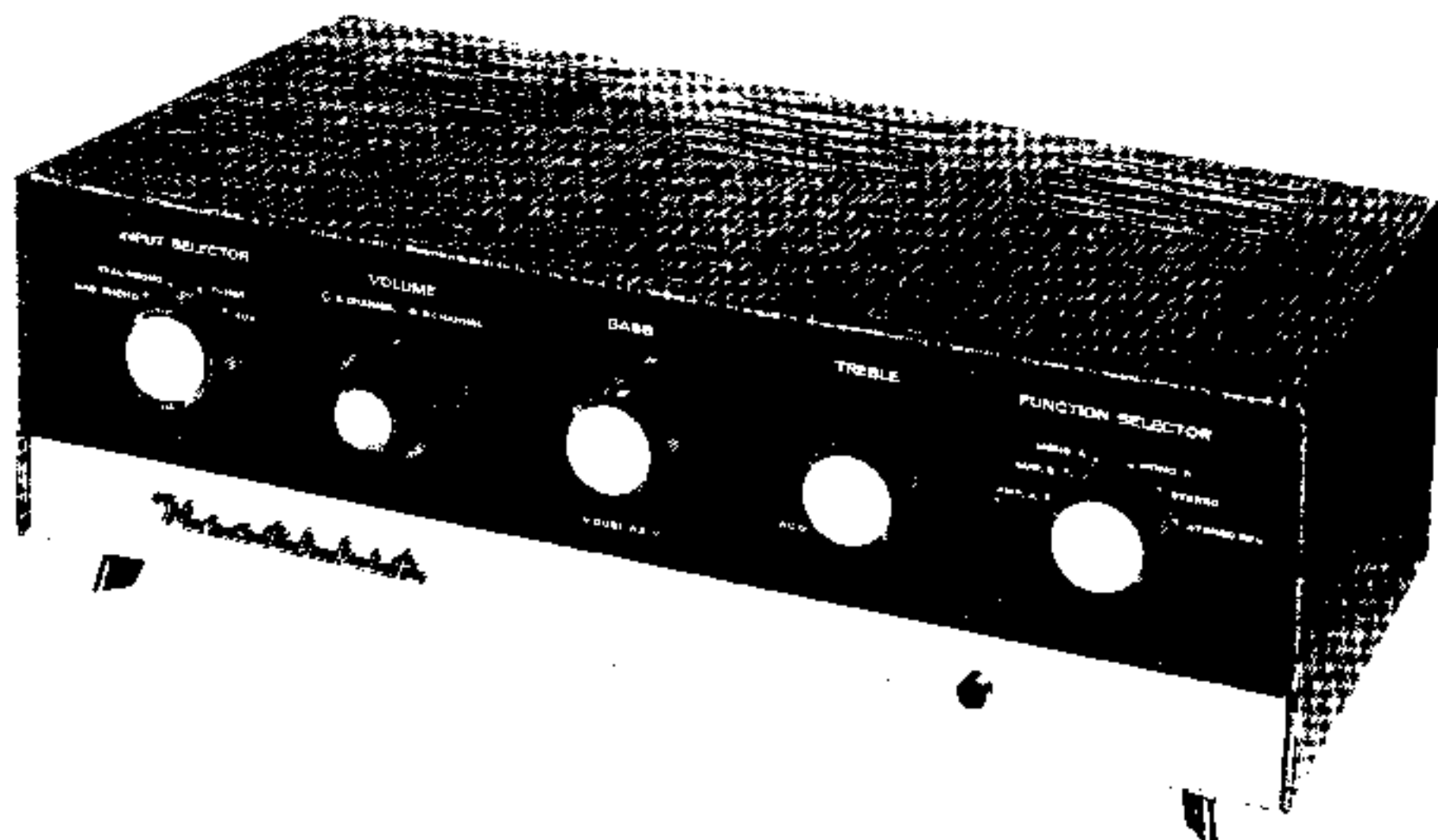

SPECIFICATIONS

The following specifications on the Model SA-2 Amplifier are presented in the belief that you are entitled to a factual and comprehensive technical report on the performance of this two channel amplifier.

These specifications are based on actual measurements taken on a typical SA-2 Amplifier, using modern, accurate test equipment. Measurements were made under the most carefully controlled conditions; not to present the most favorable advertising information, but in strict accordance with the Heath Company's published amplifier rating standards.

Minor variations from these specifications may be encountered in kit-assembled amplifiers. Such factors as exact lead placement, component variations and tube characteristics are possible sources of deviations. In a highly stable amplifier such as the SA-2, these variables may be disregarded from a performance point of view.

POWER OUTPUT:

Rated Power (rms):..... 14 watts per channel, 28 watts monophonic.
Peak Power:..... 28 watts per channel, 56 watts monophonic.

POWER RESPONSE:

± 1 db from 20 to 20,000 cycles at 14 watt level. Controlled high and low frequency roll-off for maximum transient stability. The frequency response curve is shown in Graph A.

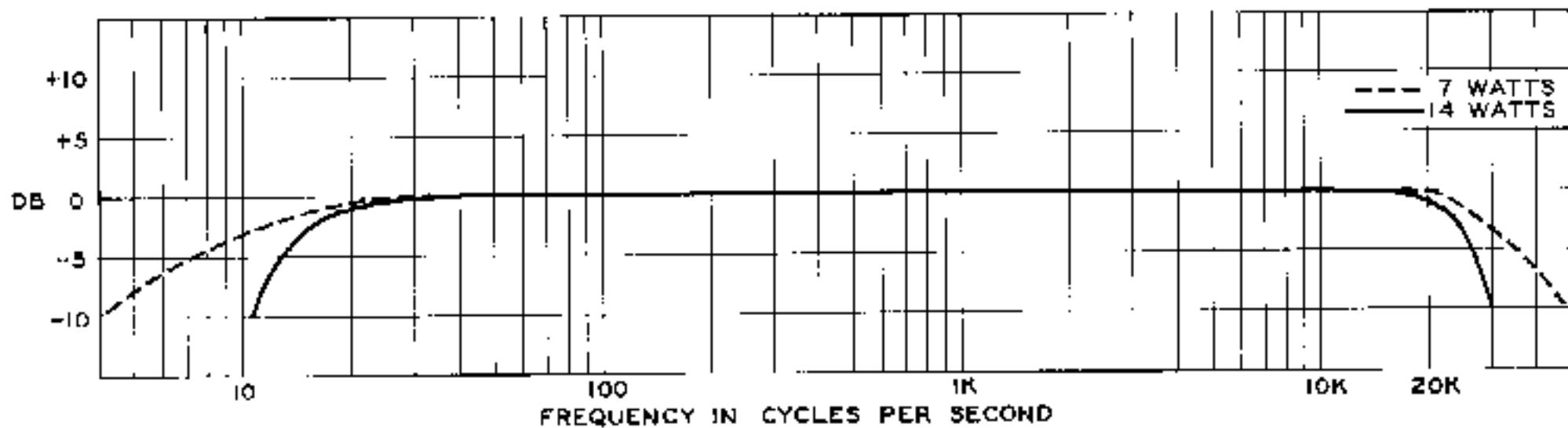

Graph A
Frequency Response

TONE CONTROL:

Separate tandem bass and tandem treble tone controls. Bass control provides approximately 19 db boost and 17 db cut at 30 cps. Treble control provides approximately 13 db boost and 17 db cut at 15,000 cps. See Graph B for curves.

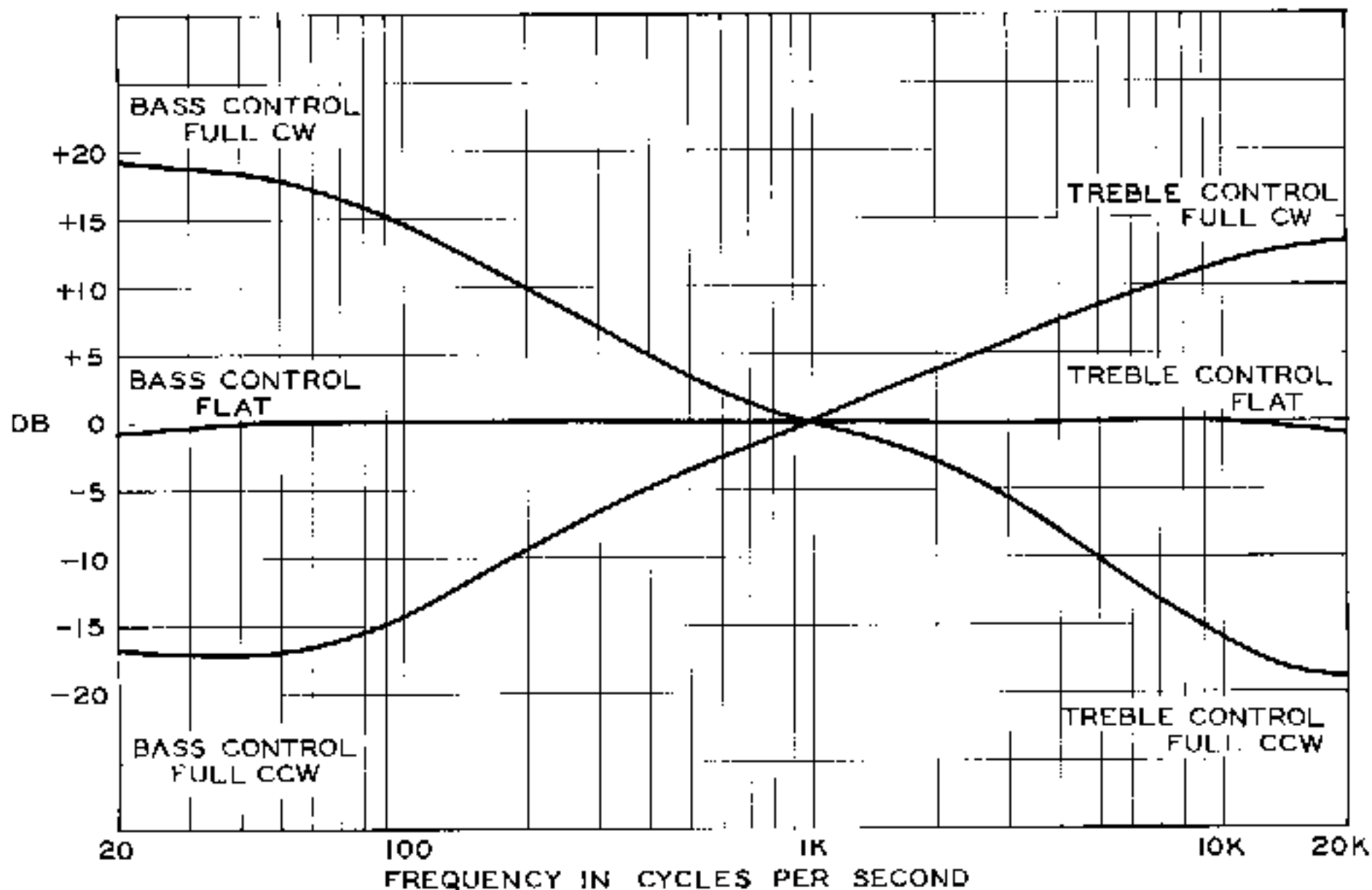

Graph B
Tone Control

HARMONIC DISTORTION:

Graph C shows total harmonic distortion versus frequency at several power levels. Competent authorities seem to agree that a total of 2% total harmonic distortion is tolerable for musical reproduction through wide-range audio equipment. Harmonic distortion below 0.7% is completely imperceptible, even to highly trained critical observers.

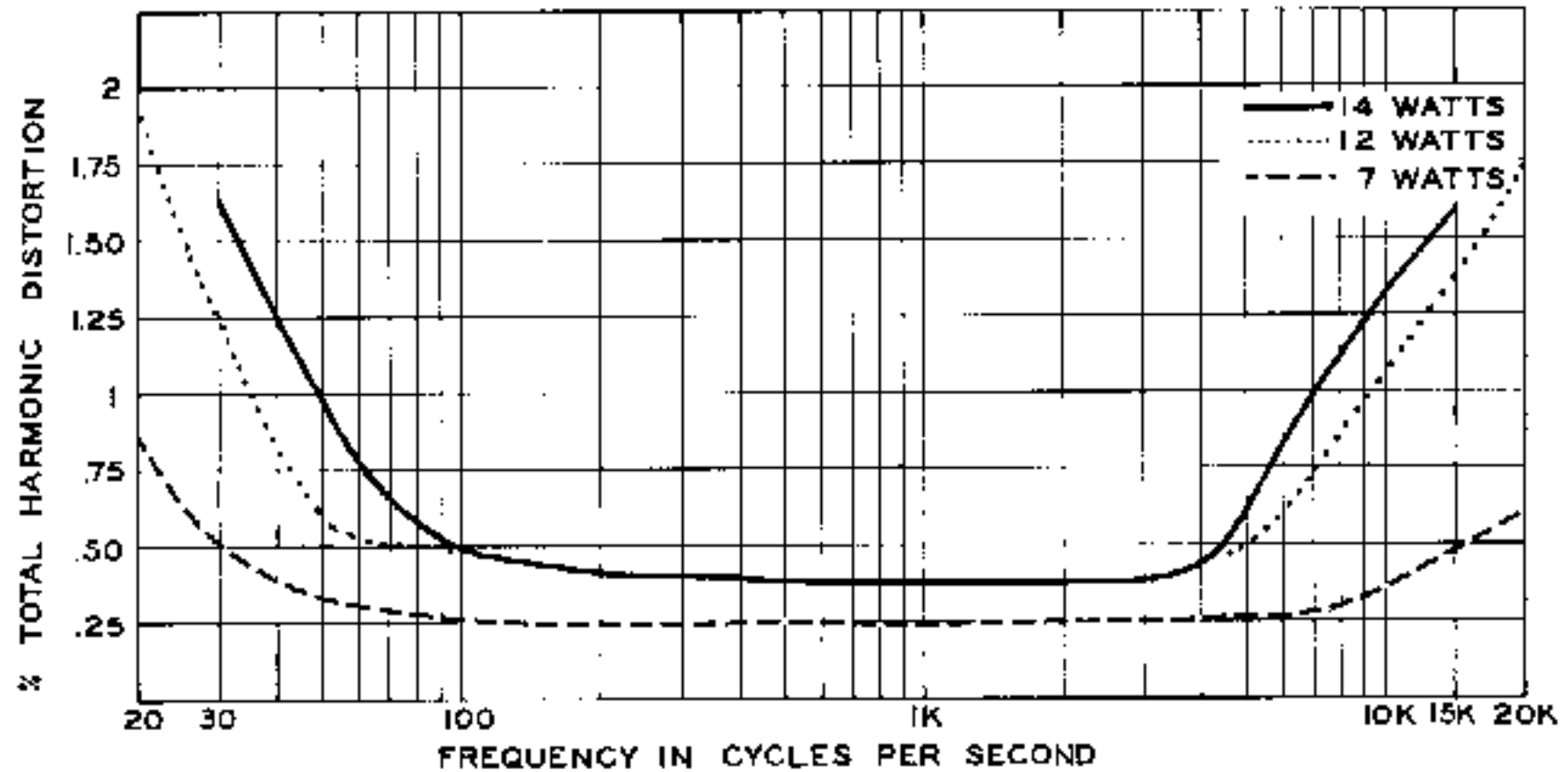

Graph C
Harmonic Distortion

PHONOGRAPH COMPENSATION:

The built-in preamplifier features RIAA (Record Industry Association of America, Inc.) compensation for magnetic type cartridges. Graph D shows a reproduction of the RIAA characteristic along with the response of the SA-2 Preamplifier. Note that the preamplifier has been carefully designed to reproduce the standard playback characteristic accurately, thereby insuring accurate reproduction of recorded material.

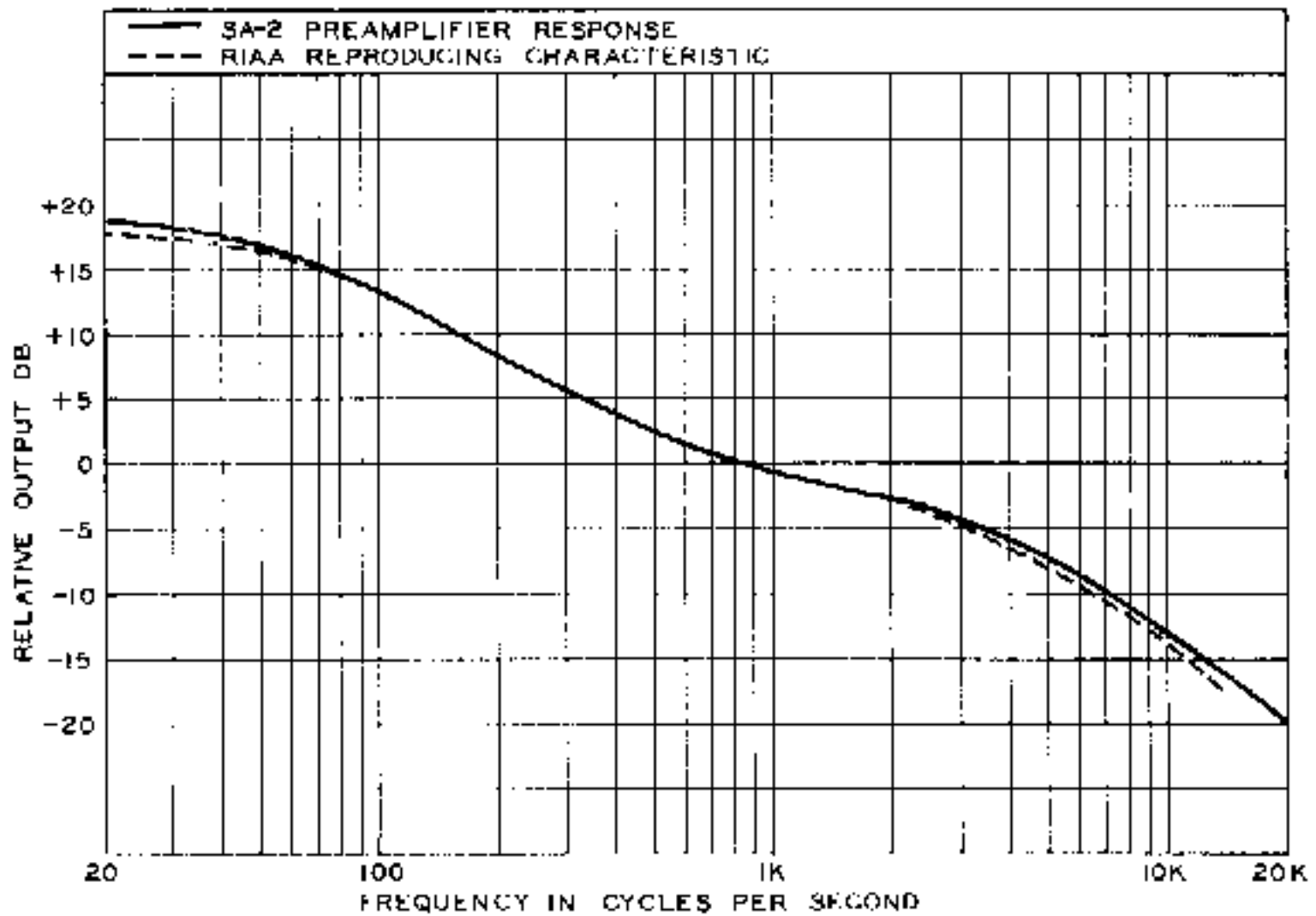

Graph D
Phonograph Compensation

INTERMODULATION DISTORTION:

Graph E shows intermodulation distortion versus power output. Note that the generally accepted limit for "extremely high fidelity" amplifiers (1% IM distortion) is not exceeded, even at full rated power.

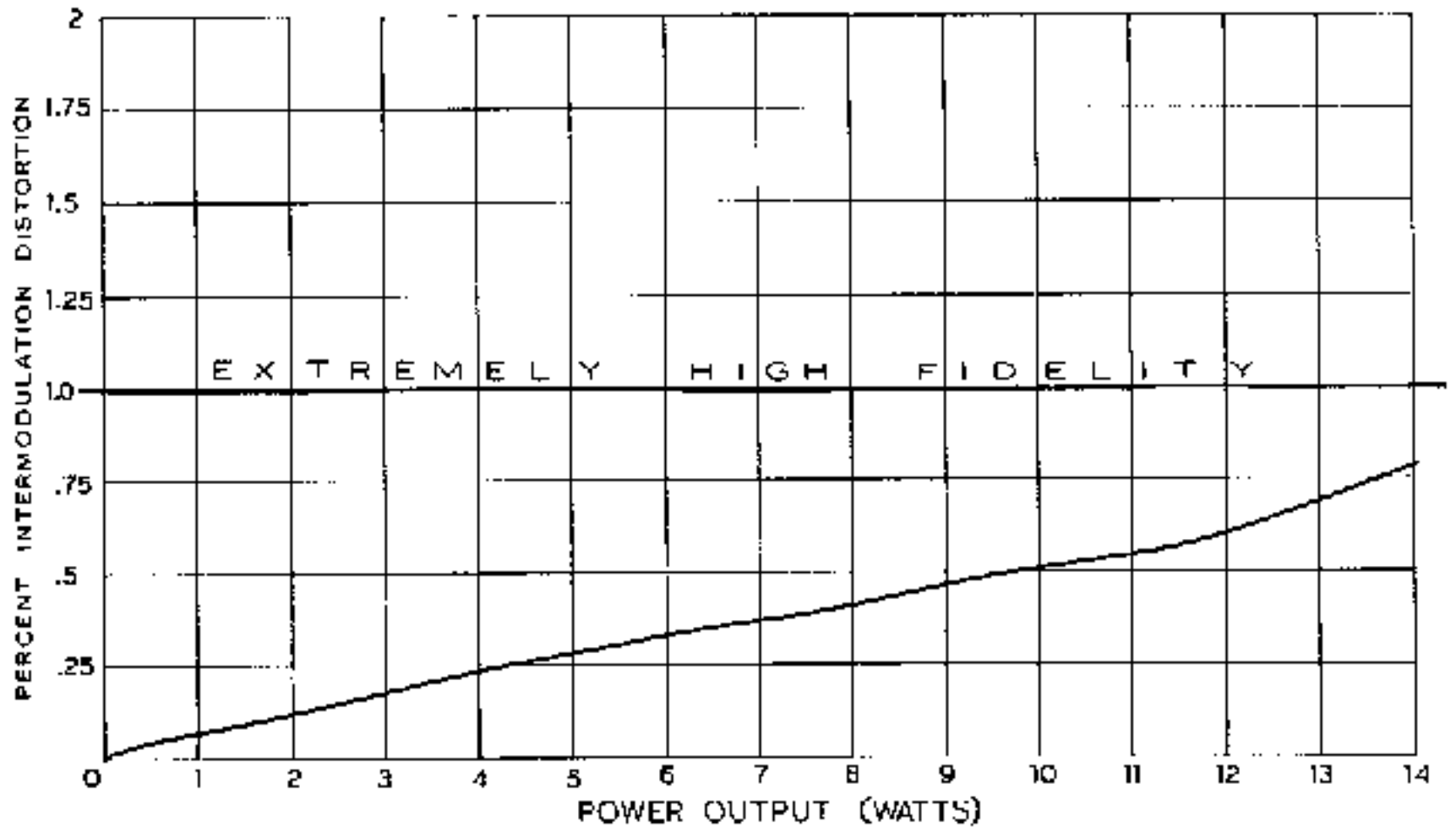

Graph E
Intermodulation Distortion

INPUT-OUTPUT SENSITIVITY:

Graph F indicates input voltage requirements for any power or voltage output level. For example: .15 V into the crystal input will produce 10.6 volts RMS across 16.02 Ω, or 7 watts.

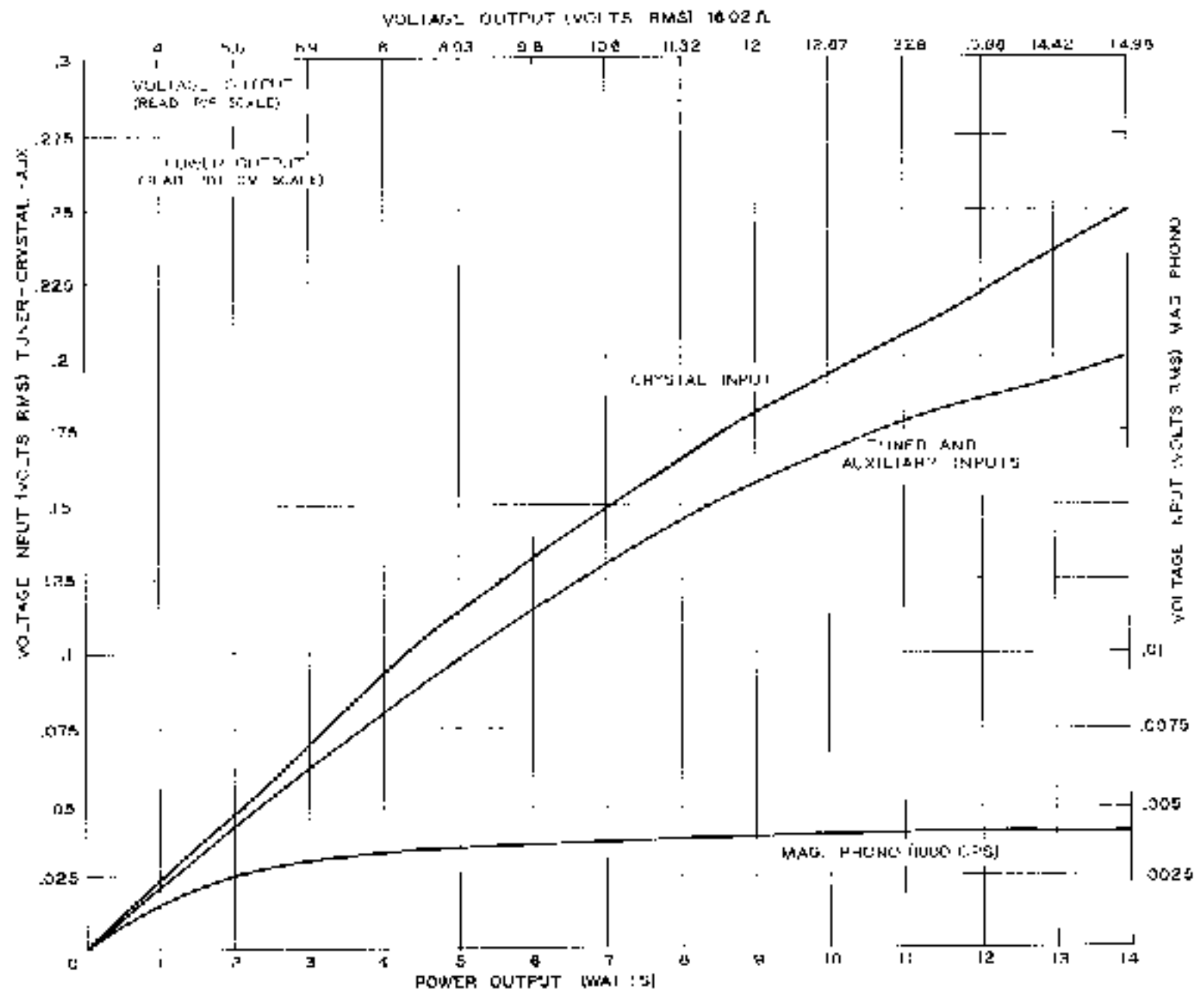

Graph F
Sensitivity

OVERLOAD RECOVERY:

A power amplifier such as the SA-2 may occasionally be subjected to overload by heavy bass passages and transients. Regardless of the rated power output of an amplifier, it is extremely important that the overload clipping be symmetrical and that recovery after overload be smooth, without oscillation.

Oscillogram 1 shows the output waveform at 14 watts, 400 cycle frequency (note that this is still below the overload point). In Oscillogram 2, the amplifier is delivering approximately 15 watts and has begun to overload. Observe, however, that the clipping is perfectly symmetrical.

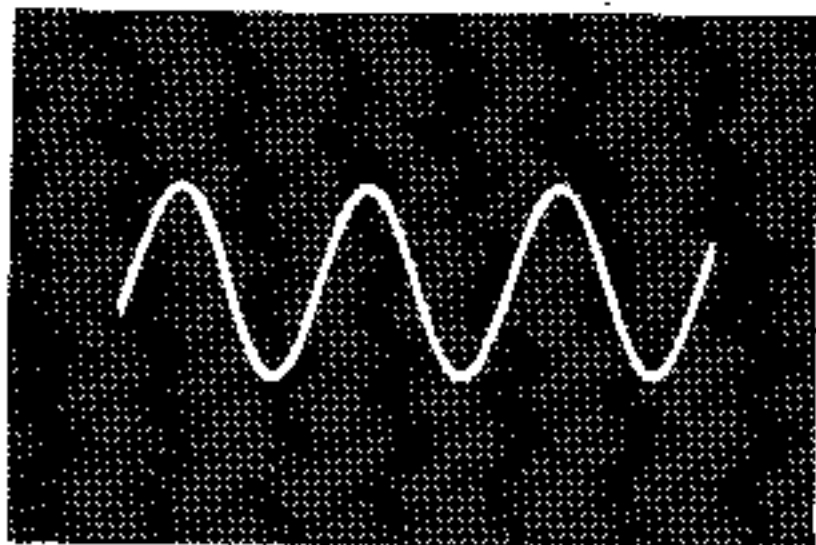

Oscillogram 1

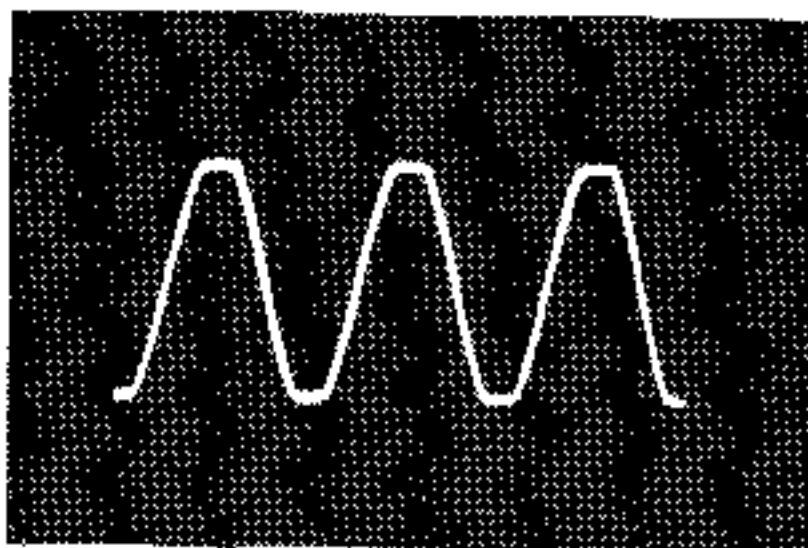

Oscillogram 2

CHANNEL SEPARATION: Stereo Function: Better than 45 db.

HUM AND NOISE:

47 db below 14 watts, Mag-Phono input. 63 db below 14 watts, Crystal and Tuner input.

INPUT SENSITIVITY: For 14 watts output (each channel).

Mag-Phono - .004 volts at 1 kc. Crystal-Phono - .25 volts. Tuner and Aux - .2 volts, with tone controls flat.

OUTPUT IMPEDANCES:

4, 8 and 16 ohms.

DAMPING FACTOR: 4.3:1

TUBE COMPLIMENT:

2 - 12AX7	4 - 6L84/8BQ5
2 - 6AU6	1 - GZ34/5AR4
2 - 6AN8	

INPUT AND OUTPUT TERMINATIONS:

Input - Standard (phono) jacks.

Output - 4-screw terminal strip (A Channel).
5-screw terminal strip with impedance matching tap (B Channel).

CONTROLS AND SWITCHES:

INPUT SELECTOR (4-position: MAGNETIC PHONO, CRYSTAL or CERAMIC PHONO, TUNER, AUXILIARY).

VOLUME (Dual concentric with clutch)

BASS (Dual tandem)

TREBLE (Dual tandem with AC line switch)

FUNCTION SELECTOR (6 position: AMPLIFIER A, AMPLIFIER B, MONOPHONIC A, MONOPHONIC B, STEREO and STEREO REVERSE)

PHASE SWITCH (B Channel speaker phase reversal)

FILAMENT BALANCE (2) - A Channel
B Channel

AC RECEPTACLES - 1 NORMAL (unswitched)
1 SWITCHED

FINISH:

Panel - Black, with brushed gold trim plate
Cover - Black and gold vinyl-clad steel

POWER REQUIREMENTS: 117 volts, 50-60 cycles, 130 watts

POWER SUPPLY: Transformer-operated full-wave rectifier

DIMENSIONS:

Front panel..... 4 1/2" x 15"
Front panel to rear chassis apron..... 8"
Clearance required for connections to
rear apron..... 1 1/4"
Cutout for custom installation..... 4 1/16" x 14 1/2"

NET WEIGHT:.....20 lbs.

SHIPPING WEIGHT:.....23 lbs.

TEST CONDITIONS:

Load Impedance..... Dummy load, 16.02 ohms resistive
Line Voltage..... 117.0 volts, 60 cycles, regulated

GENERATORS:

For harmonic distortion measurements, Krohn-Hite Model 440-A, inherent distortion less than 0.1%. For frequency response measurements, Hewlett-Packard Model 650-A Test Oscillator.

DISTORTION:

Total harmonic distortion measurements, Hewlett-Packard Model 330-B Distortion Analyzer. Intermodulation distortion, Heathkit AA-1 Audio Analyzer.

POWER OUTPUT METERING:

Hewlett-Packard Model 400-D Electronic Voltmeter across 16.01 ohm resistive load.

OSCILLOGRAMS:

Fairchild Camera on Tektronix Model 515 Oscilloscope.

INTRODUCTION

The Heathkit SA-2 Stereo Amplifier is in essence two 14 watt true high fidelity amplifiers and preamplifiers, contained in one attractively styled unit, using a common power supply. Quality, versatility, styling, and economy are the four basic key notes to which the SA-2 was designed.

A few minutes spent comparing the preceding specifications with competitive units will show the outstanding quality of this fine stereo amplifier. These are the specifications your amplifier will deliver if the step-by-step construction is followed carefully.

The versatility of having two independent preamplifiers and two independent power amplifiers as are used in the SA-2 cannot be duplicated by separate monophonic amplifiers occupying the same space. Either preamplifier may be connected to either or both amplifiers to deliver 14 or 28 watts, respectively, of true high fidelity monophonic reproduction, or either preamplifier may be connected to either power amplifier to produce a full 14 watts per channel stereo. Eight independent monophonic sources or four stereo sources may be permanently connected to the input jacks and each selected by means of the input and function selector switches. The output level of the amplifiers may be controlled simultaneously or individually by means of the clutch type volume control.

Economy designed into the SA-2, as compared to two separate monophonic amplifiers of similar specifications, was realized only through the common cabinet, chassis and power supply without degradation of quality or versatility.

Styling has played a very important part in the finish design of the SA-2. With its virtually indestructible vinyl-clad steel cabinet, the SA-2 is attractively styled to blend with all types of room decor and thus may be proudly displayed in the open. With the cabinet removed, the front panel will add beauty to your custom installation. There is a full scale template included with the large folded pictorials for easier installation in your existing enclosure.

CIRCUIT DESCRIPTION

The SA-2 Stereo Monaural Amplifier may be considered as four separate units using a common power supply; namely, A Channel preamplifier, B Channel preamplifier, A Channel power amplifier, and B Channel power amplifier. The following block diagram will simplify the basic signal paths through the four units and show how they are interconnected by the FUNCTION SELECTOR switch.

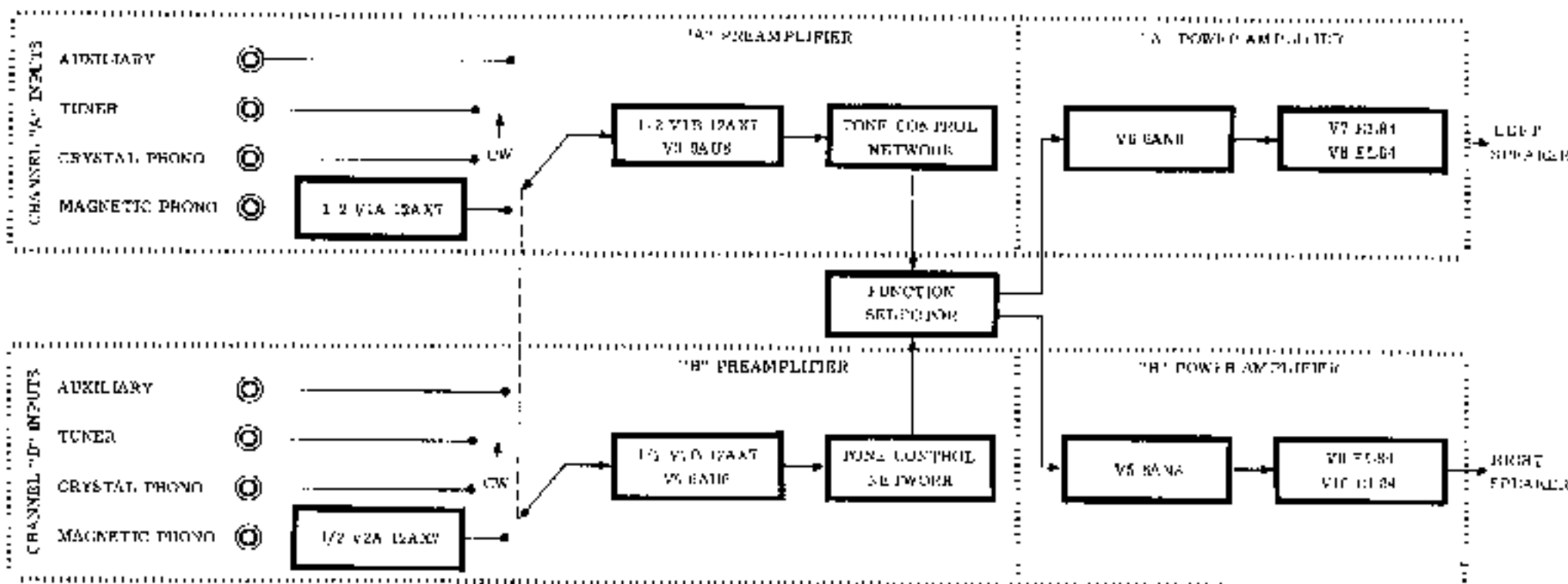

Following the block diagram and the large fold-out schematic located on the last page of this manual, we will consider four stereo signal sources connected to the input jacks of the SA-2. The low level signal source, such as a magnetic phono cartridge, should be connected to the MAG PHONO input jacks. These low level signals (A Channel for left and B Channel for the right speakers) are then directly connected to the input grid (pin 2) of a 12AX7, (V1-A for A Channel and V2-A for B Channel). The 47 K Ω resistor (R7 for A Channel - R38 for B Channel) is for proper loading for impedance matching of the magnetic cartridge. The signal is then amplified through V1-A or V2-A and coupled to the input selector switch through .1 μ f capacitors (C5 for A - C30 for B) and the 470 K Ω resistors (R10 for A - R46 for B). The .01 μ f capacitors, .0035 μ f capacitors and 22 K Ω resistors (C3, C4, and R9 for the A Channel - C28, C29, and R45 in the B Channel) are record equalization networks to flatten (equalize) the frequency response emphasized during recording.

Outputs from the low level preamplifier sections of the V1-A and V2-A are connected to the input selector switch, as well as the high level sources which include XTAL PHONO (piezoelectric crystal or ceramic phonograph cartridge), Tuner (AM, FM, or Multiplex), and AUXILIARY (tape recorder, high level microphone, television etc.). Due to the gain of the first triode halves of V1-A and V2-A for the low level signals (magnetic phono), and the voltage divider networks on the remaining inputs (R1 and R2 for A AUX input, R43 and R44 for B AUX input; R3 and R4 for A TUNER input, R41 and R42 for B TUNER input; C1, R5 and R6 for A XTAL PHONO input; C27, R39 and R40 for B XTAL PHONO input), four stereo sources of approximately equal amplitude are available for selection. The 10 μ f capacitors, 2.2 megohm and 220 K Ω resistors used with the XTAL PHONO input accomplish two objectives: to reduce cartridge output level to approximately the same amplitude as other sources used, and to properly load the cartridge for smoothest response.

Depending upon the INPUT SELECTOR switch position, one stereo source is coupled to the second triode half of the 12AX7 (V1-B for A - V2-B for B) through a .01 μ f capacitor (C6 for A - C31 for B) and again amplified. The other stereo sources are grounded at the INPUT SELECTOR switch automatically through the rear switch wiper.

The A signal is then coupled through a .022 μ f capacitor (C8 for A - C33 for B) to the input grid of a 6AU6 tube (V3 for A - V4 for B) and again amplified sufficiently to drive the conventional bass and treble tone control networks.

The outputs from the tone control networks are connected directly to the FUNCTION SELECTOR switch. Here the two signals, the A Channel signal and B Channel signal, are routed to the A Channel power amplifier and/or the B Channel amplifier depending upon FUNCTION SELECTOR switch position. The following is an explanation of the routing of signals for each of the six positions available on the FUNCTION SELECTOR switch.

AMP A

- A preamplifier connected to A power amplifier (14 watts maximum).
- B preamplifier open, B power amplifier connected to ground.

AMP B

- A preamplifier open, A power amplifier connected to ground.
- B preamplifier connected to B power amplifier (14 watts maximum).

MONO A

- A preamplifier connected to A and B power amplifier (28 watts maximum).
- B preamplifier open.

MONO B

- A preamplifier open.
- B preamplifier connected to A and B power amplifier (28 watts maximum).

STEREO

A preamplifier connected to A power amplifier (14 watts maximum).

B preamplifier connected to B power amplifier (14 watts maximum).

STEREO REV

A preamplifier connected to B power amplifier (14 watts maximum).

B preamplifier connected to A power amplifier (14 watts maximum).

The purpose of the first two positions, AMP A and AMP B is to balance the two amplifiers to an equal output with equal or unequal input signals to each channel. MONO A and MONO B, positions make 28 watts available for monophonic sources, if connected in place of a stereo source. STEREO and STEREO REVERSE positions allow channel reversal of a stereo source to the output reproducers (a recorded stereo version of an airplane traveling from left to right may be reversed to fly from right to left.)

With the FUNCTION SELECTOR switch in the STEREO position, the A Channel signal is applied directly to the input grid (pin 8) of V6-A, the pentode section of a 6AN8 tube and the B Channel signal is applied to the input grid (pin 8) of 6AN8, V5-A, where the signals are again amplified. The output signals of V6-A and V5-A are coupled directly to their respective triode sections, V6-B and V5-B, where each signal is divided and fed symmetrically out of phase to the EL84 power output tubes (V7 and V8 for Channel A - V9 and V10 for Channel B) through .05 μ fd capacitors (C19 and C21 for the A Channel - C44 and C45 for the B Channel).

The output of Channel A is coupled to the speaker directly through the step down output transformer and has three impedance matching taps, 4 Ω , 8 Ω and 16 Ω , to which the left speaker is connected.

The B Channel is similar, but has a speaker phase REVERSAL switch incorporated in the output transformer secondary. This switch simply reverses the phase of the B Channel speaker by reversing the B Channel speaker connections.

The power supply is a conventional full-wave rectifier (V11 - GZ31/5AR4 tube), resistor-capacitor (R34, R35, R36, C22, C23, C24, C25) "pi" filter system. A common ground connected to the chassis only at the input jacks, and separate A and B Channel filaments from the power supply with separate balance controls, are responsible for the low hum and noise figure for each channel. Negative feedback is employed in the power amplifier stages to further reduce distortion, hum and noise, flatten the frequency response and lower the internal impedance of the amplifier.

CONSTRUCTION NOTES

This manual is supplied to assist you in every way to complete your kit with the least possible chance for error. While the arrangement shown is probably not the only satisfactory arrangement, nevertheless it is the result of extensive experimentation and trial. If followed carefully, it will result in a stable instrument, operating at a high degree of accuracy and dependability. We suggest that you retain the manual in your files for future reference, both in the use of the instrument and for its maintenance.

UNPACK THE KIT CAREFULLY AND CHECK EACH PART AGAINST THE PARTS LIST. In so doing, you will become acquainted with the parts. Refer to the charts and other information on the inside covers of your manual to help you identify the components. If some shortage or parts damage is found in checking the Parts List, please read the REPLACEMENT section and supply the information called for therein, and include all inspection slips in your letter to us. Hardware items are counted by weight and there may be a few more or less than the quantity specified. If a few are missing, please obtain them locally if at all possible.

In order to expedite delivery to you, we are occasionally forced to make minor substitution of parts. Such substitutions are carefully checked before they are approved and parts supplied will work satisfactorily. In checking the Parts List for resistors, for example, you may find that a resistor with a 5% tolerance has been substituted for a resistor with a 10% tolerance, as shown on the Parts List. These changes are self-evident and are mentioned here only to prevent confusion in checking the contents of your kit.

Resistors generally have a tolerance rating of 10% unless otherwise stated in the Parts List. Tolerances on capacitors are generally even greater. Limits of +100% and -50% are common for electrolytic capacitors.

PARTS LIST

Refer to Parts Pictorial on Page 12 for proper identification of parts.

<u>PART No.</u>	<u>PARTS Per Kit</u>	<u>DESCRIPTION</u>	<u>PART No.</u>	<u>PARTS Per Kit</u>	<u>DESCRIPTION</u>
Resistors			Capacitors		
1-9	2	1 K Ω 1/2 watt (brown-black-red)	A21-3	2	10 μmf 10% 500 V
1-10	2	1.2 K Ω 1/2 watt (brown-red-red)	A21-7	2	33 μmf 10% 500 V
1-13	4	2.7 K Ω 1/2 watt (red-violet-red)	B21-21	2	200 μmf 10% 500 V
1-14	2	3.3 K Ω 1/2 watt (orange-orange-red)	B21-22	2	220 μmf 10% 500 V
1-16	1	4.7 K Ω 1/2 watt (yellow-violet-red)	B21-39	4	.0035 μfd 10% 500 V
1-20	2	10 K Ω 1/2 watt (brown-black-orange)	D21-47	2	.01 μfd 10% 50 V
1-21	1	15 K Ω 1/2 watt (brown-green-orange)	23-3	2	.01 μfd 400 V plastic molded
1-22	3	22 K Ω 1/2 watt (red-red-orange)	23-18	4	.002 μfd 600 V plastic molded
1-23	2	27 K Ω 1/2 watt (red-violet-orange)	23-28	6	.1 μfd 200 V plastic molded
1-24	4	33 K Ω 1/2 watt (orange-orange-orange)	23-50	4	.022 μfd 400 V plastic molded
1-25	2	47 K Ω 1/2 watt (yellow-violet-orange)	23-52	2	.047 μfd 400 V plastic molded
1-26	11	100 K Ω 1/2 watt (brown-black-yellow)	23-61	4	.05 μfd 400 V plastic molded
1-29	4	220 K Ω 1/2 watt (red-red-yellow)	C25-85	1	50 μfd 25 V electrolytic
1-33	10	470 K Ω 1/2 watt (yellow-violet-yellow)	B25-93	1	60-40-20-20 μfd 450/350/350/250 V electrolytic
1-34	2	680 K Ω 1/2 watt (blue-gray-yellow)	C25-95	4	10 μfd 25 V electrolytic
1-35	2	1 megohm 1/2 watt (brown-black-green)	Controls-Switches-Knobs		
1-37	2	2.2 megohm 1/2 watt (red-red-green)	10-61	2	200 Ω linear tab mounting
1-121	2	120 K Ω 1/2 watt (brown-red-yellow)	D12-19	1	Dual 1 megohm audio, CLUTE VOLUME control
1A-7	4	47 K Ω 1 watt (yellow-violet-orange)	A12-21	1	Dual 1 megohm audio, BASS control
3G-9	1	100 Ω 7 watt	A14-1	1	Dual 1 megohm audio, TREBLE control/AC switch
			60-2	1	DPDT phase reversal slide switch
			63-215	1	4-position input switch
			63-216	1	6-position function switch
			462-70	1	Large knob, A Channel volume
			462-71	1	Small knob, B Channel volume
			462-78	4	Medium knobs, input-bass-treble-function

<u>PART No.</u>	<u>PARTS Per Kit</u>	<u>DESCRIPTION</u>	<u>PART No.</u>	<u>PARTS Per Kit</u>	<u>DESCRIPTION</u>
Transformers-Tubes-Lamps			Cabinet-Chassis Parts-Shields		
51-29	2	Audio output transformer	90-M117	1	Cabinet
54-93	1	Power transformer	100-M241	1	Front Panel
411-11	2	6AU6 tube	200-M236	1	Chassis
411-26	2	12AX7 tube	204-M275	1	Input phono jack bracket
411-68	2	6AN8 tube	205-M192	1	Chassis bottom plate
411-108	4	EL84/6BQ5 tube	206-3	2	9-pin tube shield
411-136	1	GZ34/5AR4 tube	206-55	2	9-pin tube shield base
412-13	1	Red neon pilot lamp	206-M130	1	Input shield plate
Terminal Strips-Sockets			Hardware		
423-1	1	Fuse holder	250-8	14	#6 x 3/8" BH sheet metal screw
431-1	2	Dual 1-lug terminal strip	250-49	36	3-48 x 1/4" BH machine screw
431-2	2	2-lug terminal strip	250-56	26	6-32 x 1/4" BH machine screw
431-3	4	3-lug terminal strip	250-89	6	6-32 x 3/8" BH machine screw
431-5	2	4-lug terminal strip	252-1	36	3-48 x 7/32" nut
431-13	1	4-lug, screw type terminal strip	252-3	30	6-32 x 1/4" nut
431-17	1	5-lug, screw type terminal strip	252-4	12	8-32 x 3/8" nut
431-27	2	3-lug terminal strip	252-7	5	Control nut
431-35	2	7-lug terminal strip	252-32	1	Push-on speednut
434-15	2	7-pin miniature wafer tube socket	253-10	5	Control flat washer
434-16	4	9-pin miniature wafer tube socket	254-1	40	#6 internal lockwasher
434-20	2	110 V AC receptacle	254-2	12	#8 internal lockwasher
434-58	1	Octal tube socket	254-7	8	#3 internal lockwasher
434-68	4	9-pin molded tube socket	255-1	4	1/8" spacer
434-82	4	Double phono jack	259-11	1	#6 spade lug
Wire			Miscellaneous		
89-1	1	Line cord	73-4	1	Rubber grommet
340-1	1	Length #14 bare wire	A75-24	1	Line cord strain relief
343-3	1	Length shielded cable	261-11	4	Plastic feet
344-1	4	Lengths hookup wire (1 black, 1 red, 1 green, 1 blue)	390-87	1	Label sheet
344-2	1	Length stranded wire	391-6	1	Heathkit logotype nameplate
346-1	1	Length insulating sleeving	421-3	2	2 ampere Slo-Blo fuse
			481-3	1	Capacitor mounting wafer
			595-291	1	Manual

6-32 x 3/8" BHMS #250-89

#8 Lockwasher #254-2

8-32 Nut #252-4



Control Flat Washer #253-10

6-32 x 1/4" BHMS #250-56

#6 Lockwasher #254-1

6-32 Nut #252-3

3-48 x 1/4" BHMS #250-19

#3 Lockwasher #254-7

3-48 Nut #252-1



Control Nut #252-7

#6 x 3/8" BH Sheet Metal Screw #250-8



3-lug Terminal Strip #431-3



3-lug Terminal Strip #431-27



2-lug Terminal Strip #431-2



1-lug Terminal Strip (Dual) #431-1



Tubular Electrolytic Capacitor



Line Cord Strain Relief #A75-24

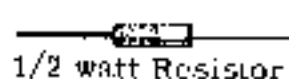

1/2 watt Resistor

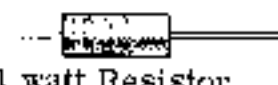

1 watt Resistor



Ceramic Disc Capacitor



Paper Capacitor Plastic Molded

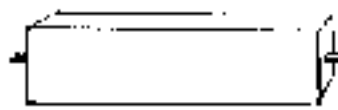

7 watt Resistor

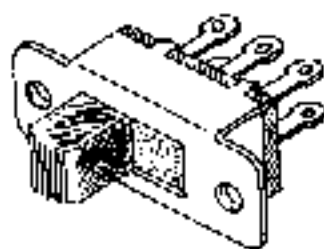

Slide Switch #60-2



Filament Balance Control #10-61



Double Phone Jack #434-82



Tube Shield #206-3

4-prong Mounting Wafer #481-3

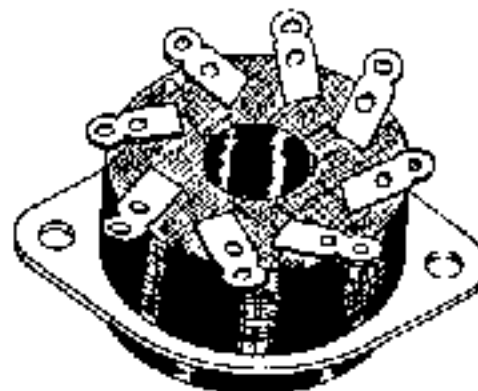
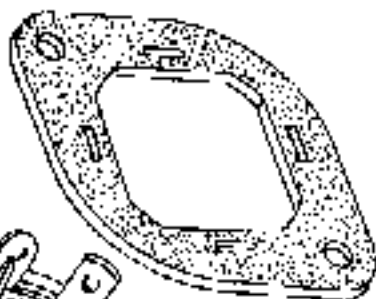

Octal Socket #434-58



Tube Shield Base #206-55

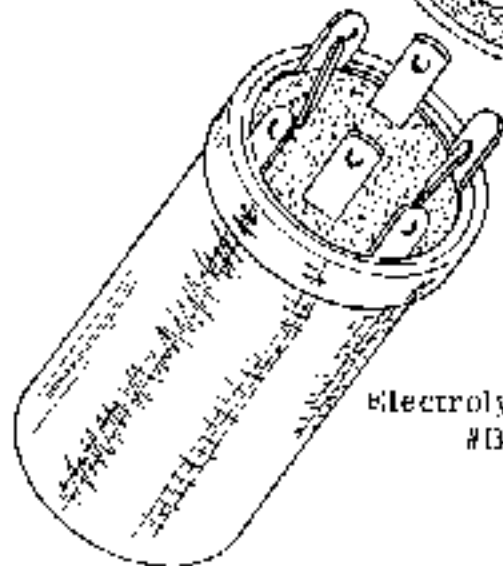

Electrolytic Capacitor #B25-93



7-pin Wafer Socket #434-15



9-pin Wafer Socket #434-16



9-pin Molded Socket #434-68

STEP-BY-STEP PROCEDURE

The following instructions are presented in a logical step-by-step sequence to enable you to complete your kit with the least possible confusion. Be sure to read each step all the way through before beginning. When the step is completed, check it off in the space provided. This is particularly important as it may prevent errors or omissions, especially if your work is interrupted. Some kit builders have also found it helpful to mark each lead in colored pencil on the pictorial as it is added.

We suggest that you do the following before work is started:

1. Attach the large folded pictorials to the wall above your work bench.
2. Read several steps ahead of the actual step being performed. This will familiarize you with the relationship of the subsequent operations.
3. Lay out all parts so that they are readily available.
4. Provide yourself with good quality tools. Basic tool requirements consist of a screwdriver with a 1/4" blade; a small screwdriver with a 1/8" blade; long-nose pliers; wire cutters, preferably separate diagonal cutters; a pen knife or a tool for stripping insulation from wires; a soldering iron (or gun) and rosin core solder. A set of nut drivers and a nut starter, while not necessary, will aid extensively in construction of the kit.

Most kit builders find it helpful to separate the various parts into convenient categories. Muffin tins or molded egg cartons make convenient trays for small parts. Resistors and capacitors may be placed with their lead ends inserted in the edge of a piece of corrugated cardboard until they are needed. Values can be written on the cardboard next to each component. The illustration shows one method that may be used.

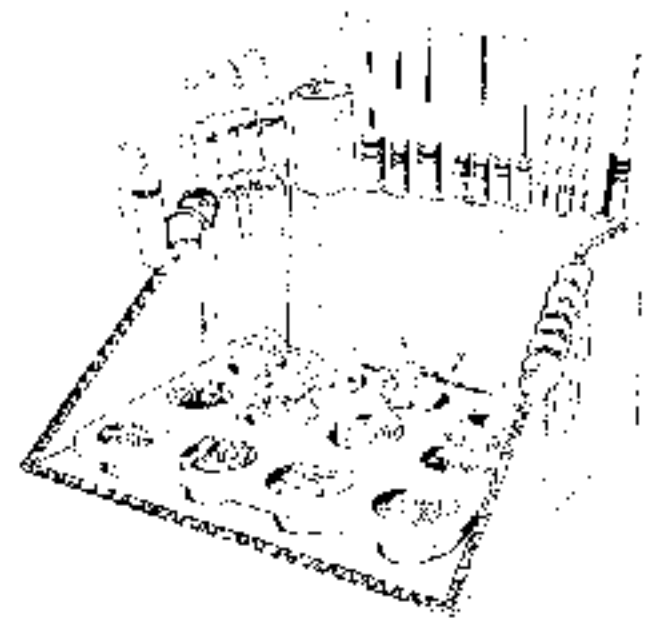

STEP-BY-STEP

MECHANICAL ASSEMBLY

- () Place the chassis upside down on the work area and orient it as shown in Pictorial 1 on Page 14. The three large transformer cutouts should be toward you with the chassis resting on the large front apron. Before mounting each part on the chassis, compare it to the respective part on the Pictorial, to assure positive identification and position of components.

A
C
I
f

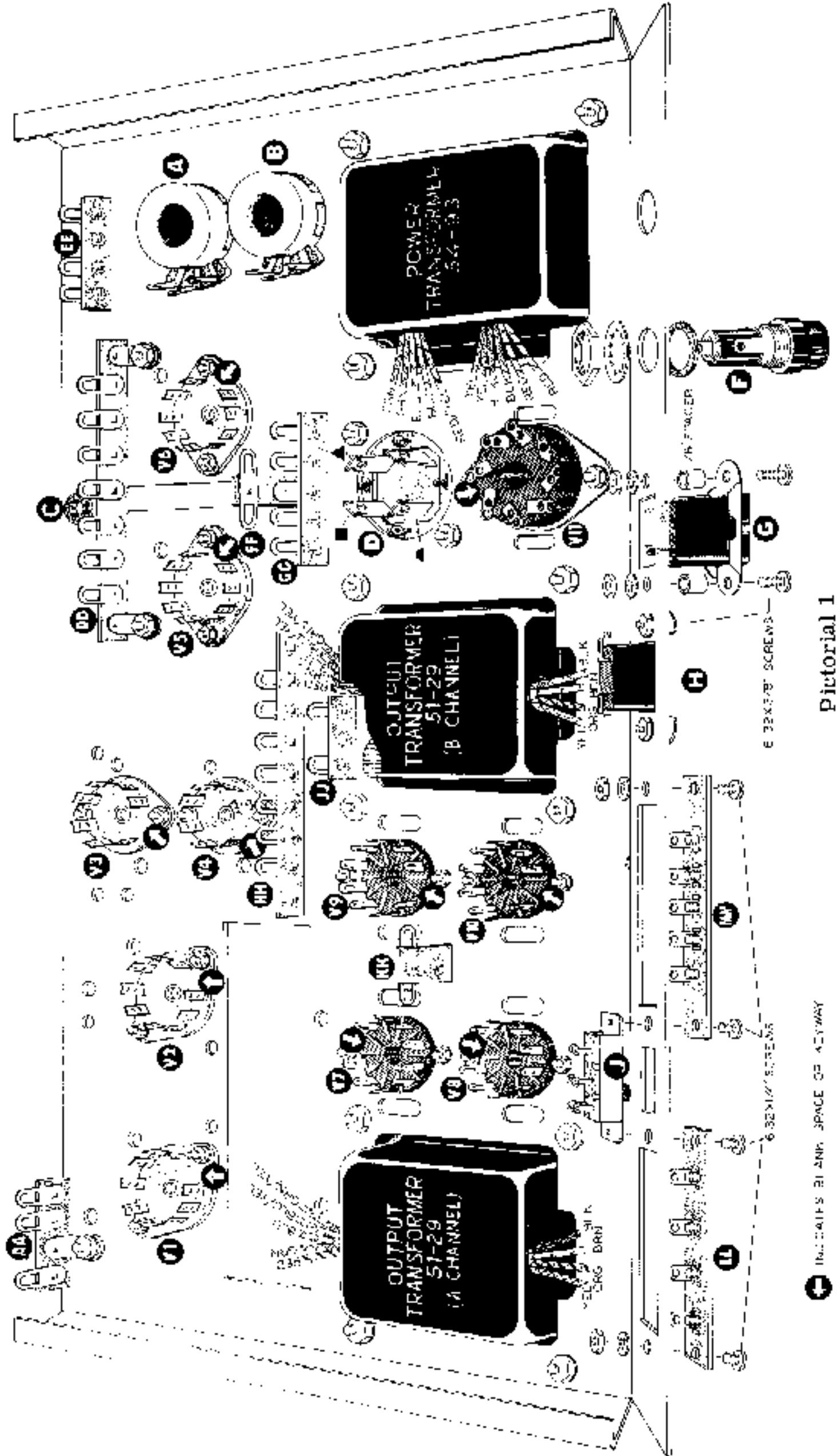

Pictorial 1

↑ INDICATES 21 AMP. SPACE OR 4CYWAY

- (✓) Starting with the upper left corner of the chassis, mount a 3-lug terminal strip at location AA. Position as shown using a #6-32 x 1/4" screw, two #6 lockwashers, and nut. Refer to Detail 1A for proper mounting procedure.

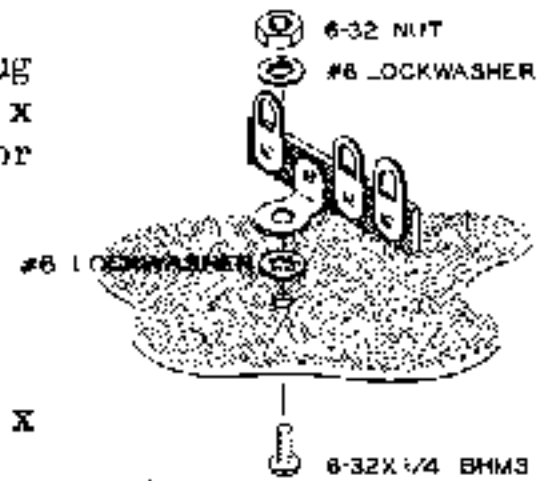

Detail 1A

- (✓) Install the one rubber grommet at C.
- (✓) Select a 7-lug terminal strip and mount at DD, using two #6-32 x 1/4" screws, four #6 lockwashers, and two nuts.
- (✓) Mount a 3-lug terminal strip at position EE as shown.

- (✓) Locate the two 200 Ω linear twist tab controls (#10-61) and install them at locations A and B as shown in Pictorial 1. Refer to Detail 1B for proper mounting to the chassis.

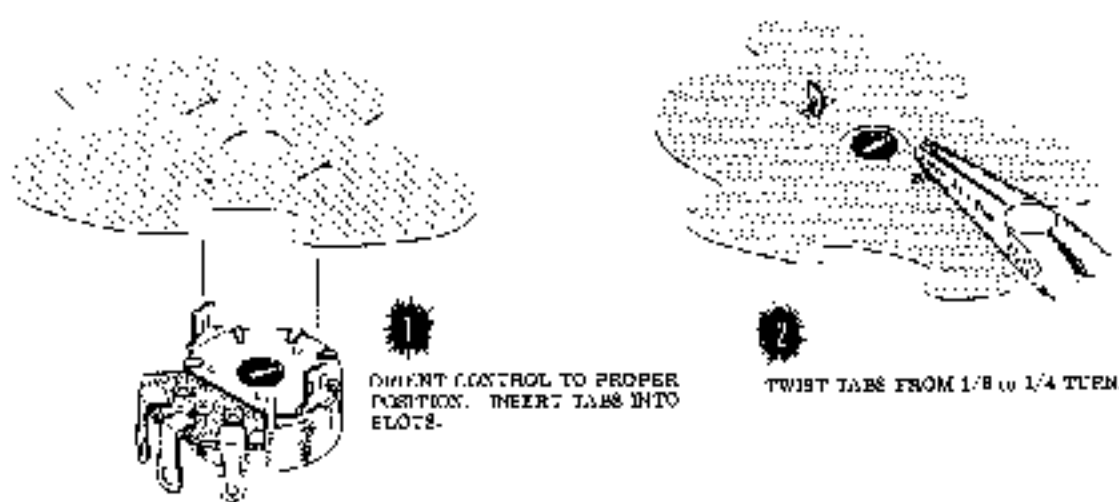

Detail 1B

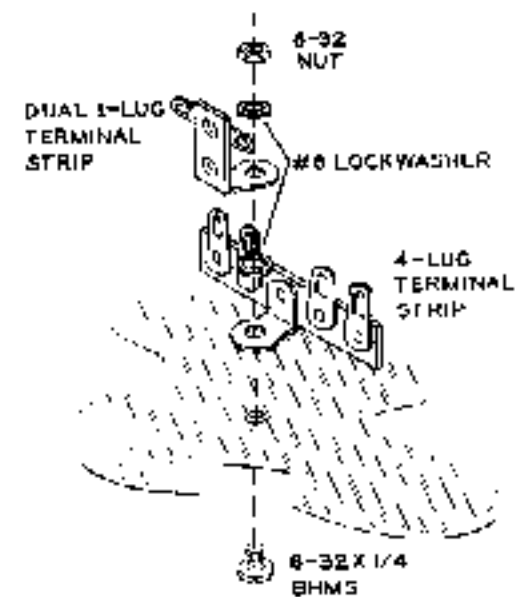

Detail 1C

- (✓) Install a dual 1-lug terminal strip and a 4-lug terminal strip at positions FF and GG as shown in Pictorial 1. Refer to Detail 1C for proper mounting. Note that both terminal strips are mounted using one screw through a common hole in the chassis.
- (✓) Locate a 7-lug terminal strip and mount as shown at IIII.
- (✓) Install a 2-lug terminal strip at JJ as shown in Pictorial 1.
- (✓) Mount a dual 1-lug terminal strip at KK.
- (✓) Refer to Detail 1D on Page 16 and mount 9-pin wafer tube sockets with shield base at locations V1 and V2. Orient the blank pin as shown in Pictorial 1. Use 3-48 x 1/4" hardware. Note that the socket wafer is mounted underneath the chassis.
- (✓) Install a 7-pin tube socket at positions V3 and V4. These wafer tube sockets are mounted as in Detail 1D with the exception that the shield base is omitted. Note the blank pin location. Again, mount the socket underneath the chassis.
- () Mount the two remaining 9-pin wafer tube sockets at V5 and V6. Note the blank pin location.
- (✓) Install the four 9-pin molded tube sockets at V7, V8, V9 and V10 through the top of the chassis. Refer to Detail 1D for proper mounting and use of hardware. Note the location of the blank pin for each socket as shown in Pictorial 1.

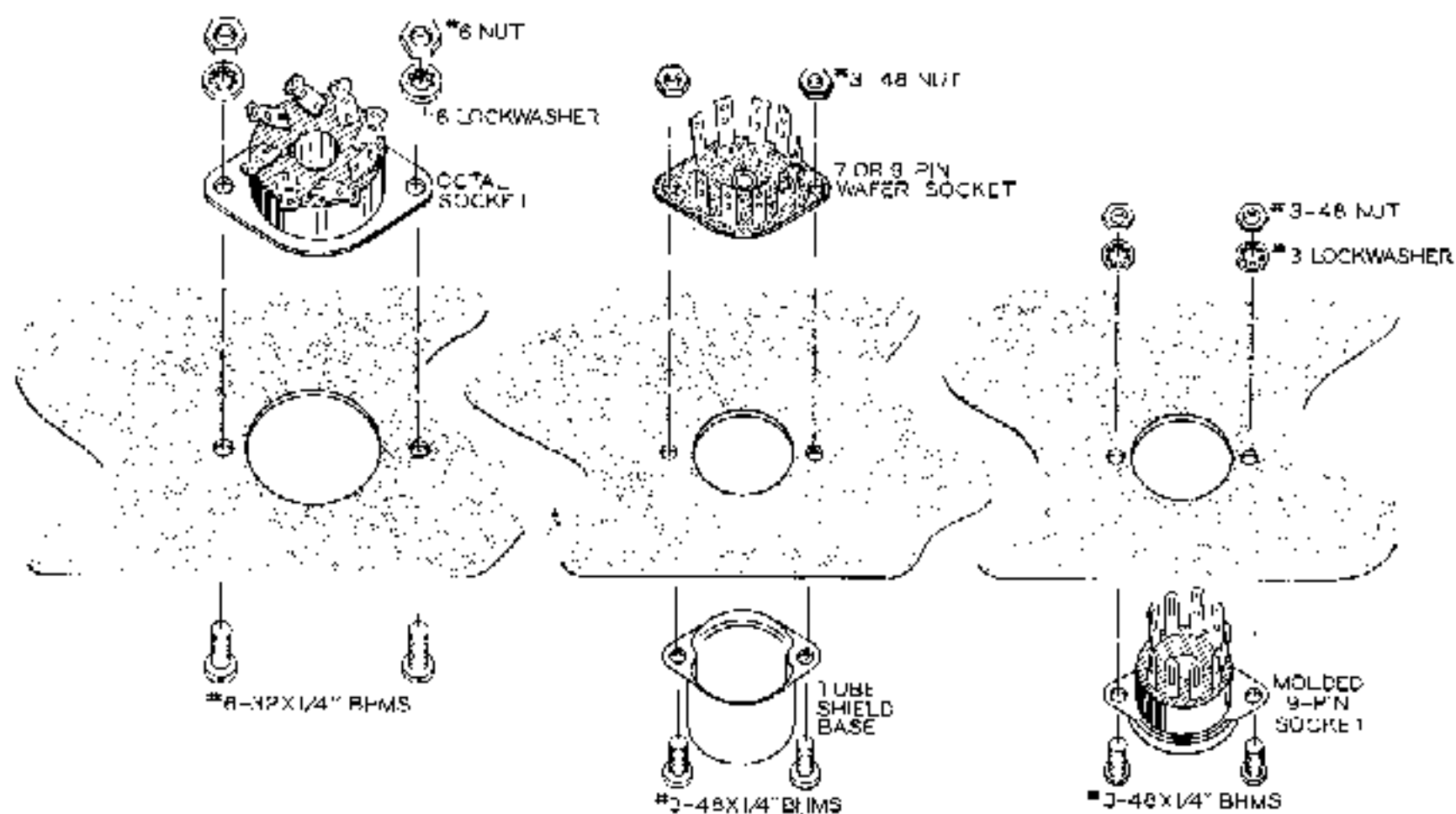

Detail 1D

- (✓) Place the capacitor mounting wafer ON TOP of the chassis at D and install with 6-32 x 1/4" screws, lockwashers and nuts.
- (✓) Note the keyway and raised dot on the octal socket and mount at location V11 from the bottom of the chassis. Secure with 6-32 x 1/4" screws, lockwashers and nuts as shown in Detail 1D.
- (✓) Locate the fuse holder and mount as shown in Pictorial 1.
- (✓) Install the two 110 V AC receptacles at positions G and H. Bend lugs G2, H1 and H2 as shown in Pictorial 1. Use 6-32 x 3/8" screws, 1/8" spacers, lockwashers and nuts.
- (✓) Refer to Pictorial 1 and mount the 5-lug screw type terminal strip, the DPDT slide switch, and the 4-lug screw type terminal strip at locations MM, J, and LL. Note the common screws securing the terminal strips and slide switch J. The inside lugs of the terminal strips are closest to the chassis. No nuts or lockwashers are necessary on screws holding switch J.
- (✓) Identify one output transformer (#51 29) and trim the leads to the following lengths, then strip 1/4" of insulation from each end and tin:

Yellow - 1 1/8"
 Orange - 1"
 Brown - 1 1/8"
 Black - 1 3/8"

Blue - 3 3/4"
 Green - 3 3/4"
 Blue-Yellow - 2 1/2"
 Green-Yellow - 2 1/2"

DO NOT trim the RED lead, it is the proper length.

- (✓) Install the prepared transformer in position A CHANNEL OUTPUT TRANSFORMER. Secure with #8 lockwashers and nuts. Note the color and location of the leads in Pictorial 1.

(✓) Identify the other output transformer (#51-29). Trim each lead to the following lengths, then strip 1/4" of insulation from the ends and tin:

Yellow - 3 1/2"
Orange - 3"
Brown - 2 1/2"
Red - 3 1/2"

Blue - 4"
Green - 4 1/2"
Blue-Yellow - 3 1/4"
Green-Yellow - 3 1/4"

DO NOT trim the BLACK lead, it is the proper length.

- (✓) Install the prepared transformer in position B CHANNEL OUTPUT TRANSFORMER. Secure with #8 lockwashers and nuts. Note the color and location of the leads in Pictorial 1.
- (✓) Mount the power transformer (#54-93) in like manner. These leads are precut and tinned to proper length. Note the position of the leads and secure with #8 lockwashers and nuts.
- (✓) Compare the chassis with Pictorial 1. The two should be identical so far as parts mounting and orientation with the exception of the 4-section filter mounted at wafer D. Check all mounting hardware to be certain all parts are tightened securely, then proceed with the following steps.
- (✓) Turn the chassis right side up and refer to Pictorial 2 for the following steps.
- (✓) Install two 3-lug terminal strips NN and PP using one 6-32 x 1/4" screw, two #6 lockwashers and a nut. The screw is inserted from the top of the chassis. See Detail 1C for proper use of hardware.
- (✓) Mount a 3-lug terminal strip at RR. Slightly bend the strip over the large cutout in the chassis, for it must clear the tube shield to be mounted immediately in back of it later.
- (✓) Mount a 3-lug terminal strip at SS. Bend this strip slightly also to be sure it will clear the tube shield.

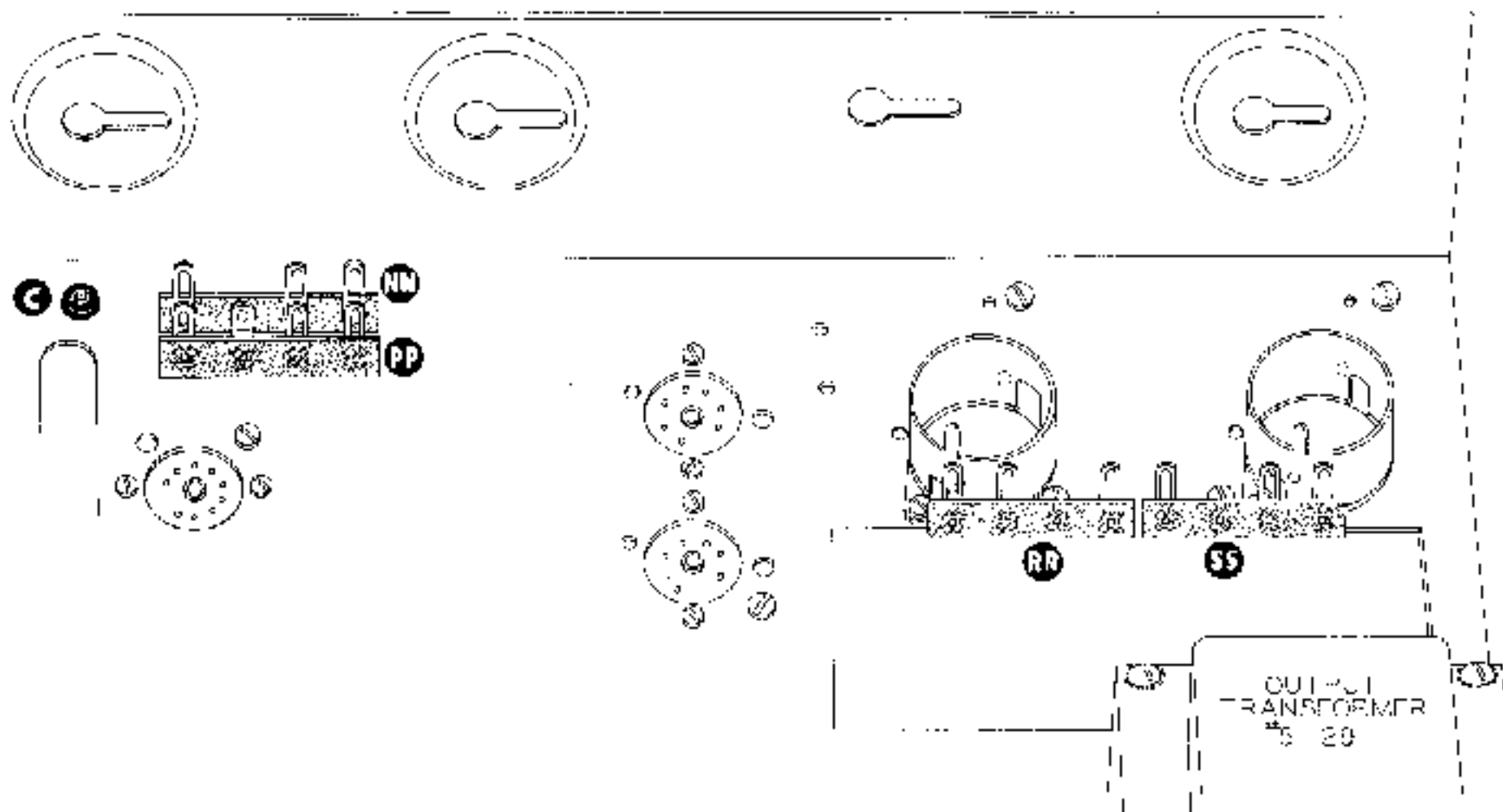

Pictorial 2

PROPER SOLDERING TECHNIQUES

Only a small percentage of Heathkit purchasers find it necessary to return an instrument for factory service. Of these instruments, by far the largest proportion of malfunctions are due to poor or improper soldering.

If terminals are bright and clean and free of wax, frayed insulation and other foreign substances, no difficulty will be experienced in soldering. Correctly soldered connections are essential if the performance engineered into a kit is to be fully realized. If you are a beginner with no experience in soldering, a half hour's practice with some odd lengths of wire may be a worthwhile investment.

For most wiring, a 30 to 100 watt iron or its equivalent in a soldering gun is very satisfactory. A lower wattage iron than this may not heat the connection enough to flow the solder smoothly over the joint. Keep the iron tip clean and bright by wiping it from time to time with a cloth.

CHASSIS WIRING AND SOLDERING

1. Unless otherwise indicated, all wire used is the type with the colored insulation (hookup wire); the size of the conductor is the same for all colors of hookup wires furnished with your kit. In the case that bare wire is to be covered with insulating sleeving, the phrase "use sleeving" will be used.
2. Leads on resistors, capacitors and transformers are generally much longer than they need to be to make the indicated connections. In these cases, the excess leads should be cut off before the part is added to the chassis. In general, the leads should be just long enough to reach their terminating points. Wherever there is a possibility of bare leads shorting to other parts or to the chassis, the leads should be covered with insulating sleeving.
3. Crimp or bend the lead (or leads) around the terminal to form a good joint without relying on solder for physical strength. If the wire is too large to allow bending, position the wire so that a good solder connection can still be made.
4. Position the work, if possible, so that gravity will help to keep the solder where you want it.
5. Place a flat side of the soldering iron tip against the joint to be soldered until it is heated sufficiently to melt the solder.
6. Then place the solder against the heated terminal and it will immediately flow over the joint; use only enough solder to thoroughly wet the junction. It is usually not necessary to fill the entire hole in the terminal with solder.
7. Remove the solder and then the iron from the completed junction. Use care not to move the leads until the solder is solidified.

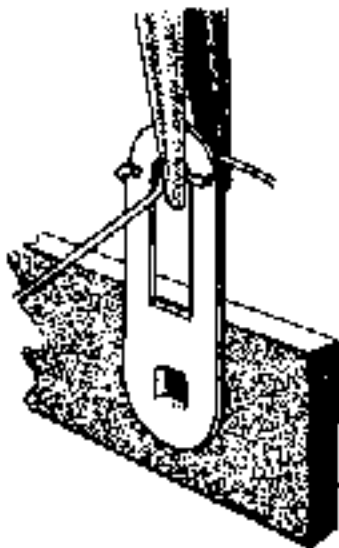

CRIMP WIRES

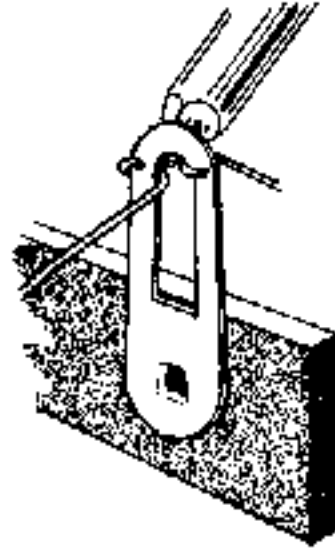

HEAT CONNECTION

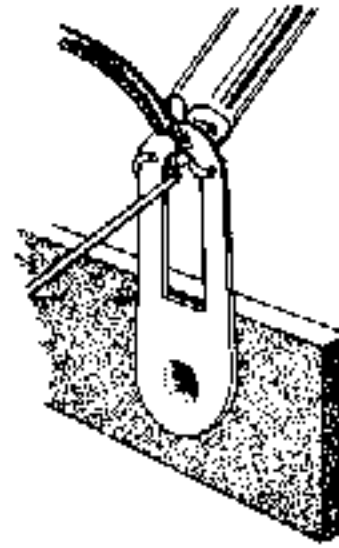

APPLY SOLDER

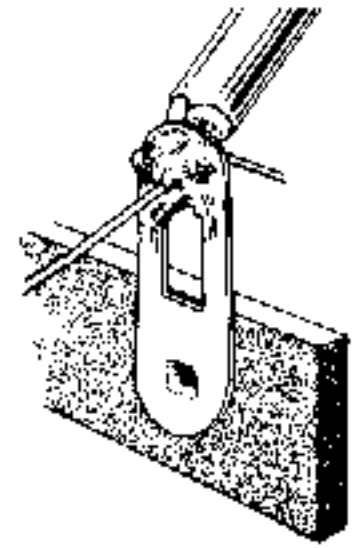

ALLOW SOLDER
TO FLOW

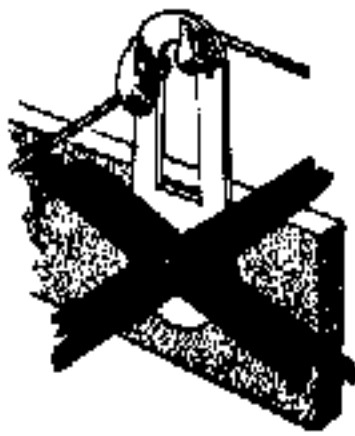

COLD SOLDER JOINT
CONNECTION INSUFFICIENTLY
HEATED

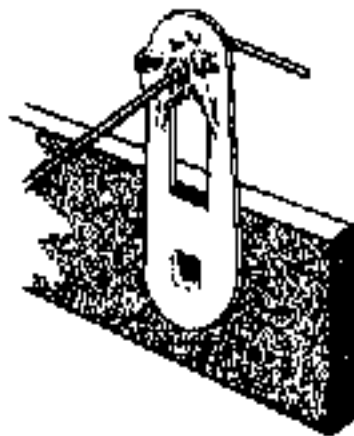

PROPER SOLDER
CONNECTION

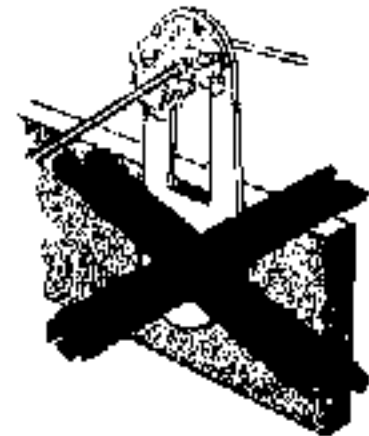

COLD SOLDER JOINT
CONNECTION MOVED
WHILE COOLING

A poor or cold solder joint will usually look crystalline and have a grainy texture, or the solder will stand up in a blob and will not have adhered to the joint. Such joints should be reheated until the solder flows smoothly over the entire junction. In some cases, it may be necessary to add a little more solder to achieve a smooth, bright appearance.

NOTE: ALL GUARANTEES ARE VOIDED AND WE WILL NOT REPAIR OR SERVICE INSTRUMENTS IN WHICH ACID CORE SOLDER OR PASTE FLUXES HAVE BEEN USED. WHEN IN DOUBT ABOUT SOLDER, IT IS RECOMMENDED THAT A NEW ROLL PLAINLY MARKED "ROSIN CORE RADIO SOLDER" BE PURCHASED.

The abbreviation "NS" indicates that a connection should not be soldered as yet for other wires may need to be added. When the last wire is installed, the terminal should be soldered and the abbreviation "S" is used to indicate this. Note that a number will appear after each solder instruction. This number indicates the number of leads that are supposed to be connected to the terminal in question before it is soldered. For example, if the instruction reads, "Connect one lead of a 47 K Ω resistor to lug 1 (S-2)," it will be understood that there will be two leads connected to the terminal at the time it is soldered. This additional check will help avoid errors.

MAIN CHASSIS WIRING

- (/) Turn the chassis upside down and refer to Pictorial 3 on the fold-out from Page 4 for the following steps. The lead dress is very critical in all chassis wiring and to assure the finest operation of the completed unit, all leads should be placed close to the chassis, and all components should be positioned exactly as shown in the pictorials.
- (/) The previously mounted transformers will be connected first, starting with the A CHANNEL OUTPUT TRANSFORMER.
- (/) Connect the YELLOW lead from the A CHANNEL OUTPUT TRANSFORMER to lug 1 of terminal strip LL (NS).
- (/) Connect the ORANGE lead to LL2 (S-4).
- (/) Connect the BROWN lead to LL3 (S-4).
- (/) Connect the BLACK lead to LL4 (NS).
- (/) Twist the BLUE and the GREEN leads located at the opposite end of the A CHANNEL OUTPUT TRANSFORMER together, dress them tight to the chassis, around the TRANSFORMER bottom bell, and connect the BLUE lead to pin 7 of V8 (S-4).

- () Connect the GREEN lead to pin 9 of V8 (S-1).
- (✓) Dress the RED lead across and close to the chassis up to lug 1 of terminal strip HH (NS). Refer to Pictorial 3 for proper lead routing.
- (✓) Twist the GREEN-YELLOW and the BLUE-YELLOW leads together and connect the BLUE-YELLOW to pin 7 of V7 (S-1).
- (✓) Connect the GREEN-YELLOW lead to pin 9 of V7 (S-1).
- (✓) Connect the BLACK lead from the B CHANNEL OUTPUT TRANSFORMER to lug 6 of slide switch J (NS).
- (✓) Connect the YELLOW lead to lug 3 of terminal strip MM (NS).
- (✓) Connect the ORANGE lead to MM4 (S-1).
- (✓) Connect the BROWN lead to MM5 (S-1).
- (✓) Dress the RED lead located at the opposite end of the B CHANNEL OUTPUT TRANSFORMER across the chassis, and up to lug 1 of terminal strip HH (NS).
- (✓) Twist the GREEN and the BLUE leads together, dress them close to the chassis, around the bottom bell of the transformer and connect the GREEN lead to pin 9 of V10 (S-1).
- (✓) Connect the BLUE lead to pin 7 of V10 (S-1).
- (✓) Twist the GREEN-YELLOW and the BLUE-YELLOW leads together and dress the twisted pair close to the chassis around the bottom bell of the transformer as shown in Pictorial 3. Connect the GREEN-YELLOW lead to pin 9 of V9 (S-1) and the BLUE-YELLOW lead to pin 7 of V9 (S-1).
- (✓) Connect the longest of the two BLACK leads from the power transformer to lug 2 of the AC receptacle G (NS).
- (✓) Connect the shorter BLACK lead to lug 2 of fuse holder F (NS).
- (✓) Twist the two RED leads together and connect the short lead to pin 4 of V11 (S-1).
- () Connect the longer RED lead to pin 6 of V11 (S-1).
- (✓) Twist the two YELLOW leads together and connect the short lead to pin 2 of V11 (S-1).
- (✓) Connect the longer YELLOW lead to pin 8 of V11 (NS).
- (✓) Twist the two GREEN leads together, dress them around the bottom bell of the transformer up to the A Channel filament balance control A. Connect the short GREEN lead to A3 (NS). Refer to Pictorial 3 for proper lead dress.
- (✓) Connect the longer GREEN lead to A1 (NS).
- (✓) Twist the two BLUE leads together, dress them over the green leads up to the B Channel filament balance control B. Connect the short BLUE lead to B3 (NS).
- (✓) Connect the longer BLUE lead to B1 (NS). The RED-YELLOW lead is not connected at this time.

In the following steps a prepared lead designates one which has been cut to the specified length and both ends stripped of 1/4" of insulation, unless otherwise stated. Refer to Pictorial 3 for the proper lead dress of each wire before performing the steps. Dress each lead close to the chassis and position exactly as shown in the pictorials to assure the finest operating amplifier.

- (✓) Prepare a 6 1/2" length of RED hookup wire and connect one end to pin 1 of V1 (NS). Dress this lead along the large chassis cutout over to lug 2 of terminal strip HH (NS).
- (✓) Prepare a 7 1/2" length of RED hookup wire and connect one end to pin 6 of V1 (NS). Dress the other end along the large chassis cutout over to lug 3 of HH (NS).
- () Prepare a 1 1/2" length of GREEN hookup wire and connect one end to pin 2 of V1 (S-1). Dress this lead through the large chassis cutout and leave it to be connected later.
- (✓) Prepare a 3 1/2" length of GREEN hookup wire and connect one end to terminal strip AA2 (NS). Dress this lead through the hole in the chassis located directly below AA2 and leave to be connected later.
- (✓) Connect one end of a prepared 4" length of BLUE hookup wire to pin 2 of V2 (S-1). Dress the other end through the large chassis cutout and leave to be connected later.
- (✓) Prepare a 5" length of RED hookup wire and connect one end to pin 1 of V2 (NS). Dress the other end close to the previously installed red wires and connect to HH4 (NS).
- (✓) Prepare a 6" length of RED hookup wire and connect one end to pin 6 of V2 (NS). Dress the other end close to the chassis near the tube socket over to HH5 (NS).
- (✓) Prepare a 6" length of GREEN hookup wire by stripping 1/4" of insulation from one end and 1/2" of insulation from the other end. Insert the 1/2" stripped end through pin 5 (S-1) over to pin 4 of V1 (S-1). Leave the other end free.
- (✓) Prepare a 6" length of BLACK hookup wire in the usual manner and connect one end to pin 9 of V1 (S-1).
- (✓) Refer to Pictorial 3 and twist the GREEN and the BLACK wires together, dress them close to the chassis and connect the GREEN wire to pin 3 of V3 (NS). Connect the BLACK WIRE to pin 4 of V3 (NS).
- (✓) Prepare a 6 3/4" length of GREEN hookup wire and connect one end to pin 3 of V3 (NS).
- (✓) Prepare a 6 1/4" length of BLACK hookup wire and connect one end to pin 4 of V3 (NS).
- (✓) Twist the pair together, dress them close to the chassis as shown in Pictorial 3 and connect the GREEN wire to pin 4 of V6 (NS). Connect the BLACK wire to pin 5 of V6 (NS).
- (✓) Prepare a 7 1/2" length of GREEN hookup wire and connect one end to pin 3 of V3 (S-3).
- (✓) Prepare a 7 3/4" length of BLACK hookup wire and connect one end to pin 4 of V3 (S-3).
- (✓) Twist the two wires together, dress them close to the chassis as shown in Pictorial 3 and connect the GREEN wire to pin 4 of V7 (NS). Connect the BLACK wire to pin 5 of V7 (NS).
- (✓) Prepare a 4" length of GREEN hookup wire, connect one end to pin 4 of V7 (S-2).
- (✓) Prepare a 4" length of BLACK hookup wire and connect one end to pin 5 of V7 (S-2).
- (✓) Twist the two wires together, dress them close to the chassis as in Pictorial 3 and connect the GREEN wire to pin 4 of V8 (S-1). Connect the BLACK wire to pin 5 of V8 (S-1).

- () Prepare a 3 3/4" length of GREEN hookup wire and connect one end to pin 4 of V6 (S-2).
- (/) Prepare a 3 3/4" length of BLACK hookup wire and connect one end to pin 5 of V6 (S-2).
- (/) Twist the two wires together, dress them close to the chassis as in Pictorial 3 and connect the GREEN wire to lug 1 on control A (S-2). Connect the BLACK wire to lug 3 of control A (S-2).
- (/) Prepare a 4 1/2" length of BLUE hookup wire by stripping 1/4" of insulation from one end and 1/2" of insulation from the other end. Insert the 1/2" stripped end through pin 5 (S-1) over to pin 4 (S-1) of V2.
- (/) Prepare a 3" length of BLACK hookup wire in the usual manner and connect one end to pin 9 of V2 (S-1).
- (/) Twist the two wires together, dress them close to the chassis as shown in Pictorial 3 and connect the BLUE wire to pin 3 of V4 (NS). Connect the BLACK wire to pin 4 of V4 (NS).
- (/) Prepare a 4 1/2" length of BLUE hookup wire and connect one end to pin 3 of V4 (NS).
- (/) Prepare a 5" length of BLACK hookup wire and connect one end to pin 4 of V4 (NS).
- (/) Twist the two wires together, dress them close to the chassis as in Pictorial 3 and connect the BLUE wire to pin 4 of V9 (NS). Connect the BLACK wire to pin 5 of V9 (NS).
- (/) Prepare a 3 1/2" length of BLUE hookup wire and connect one end to pin 4 of V9 (S-2).
- (/) Prepare a 3 1/4" length of BLACK hookup wire and connect one end to pin 5 of V9 (S-2).
- (/) Twist the two wires together, dress close to the chassis as in Pictorial 3 and connect the BLUE wire to pin 4 of V10 (S-1). Connect the BLACK wire to pin 5 of V10 (S-1).
- (/) Prepare a 4" length of BLUE hookup wire and connect one end to pin 3 of V4 (S-3).
- () Prepare a 4" length of BLACK hookup wire and connect one end to pin 4 of V4 (S-3).
- (/) Twist the two wires together, dress them close to the chassis as in Pictorial 3 and connect the BLUE wire to pin 4 of V5 (NS). Connect the BLACK wire to pin 5 of V5 (NS).
- (/) Prepare a 7" length of BLUE hookup wire and connect one end to pin 4 of V5 (S-2).
- (/) Prepare a 7" length of BLACK hookup wire and connect one end to pin 5 of V5 (S-2).
- (/) Twist the two wires together, dress them close to the chassis as in Pictorial 3 and connect the BLUE wire to lug 1 of control B (S-2). Connect the BLACK wire to lug 3 on control B (S-2).
- (/) Prepare a 3 3/4" length of RED hookup wire and connect one end to pin 5 of V3 (NS). Dress this lead as in Pictorial 3 and connect the other end to lug 6 of HH (NS).
- (/) Prepare a 3" length of RED hookup wire and connect one end to pin 5 of V4 (NS). Dress this lead as in Pictorial 3 and connect the other end to HH7 (NS).
- (/) Prepare a 12" length of BLUE hookup wire and connect one end to terminal strip DD1 (NS). Connect the other end to screw terminal strip MM3 (S-2). Dress this lead close to the chassis as in Pictorial 3.

- (✓) Prepare a 1 1/2" length of BLUE hookup wire and connect one end to DD2 (NS). Connect the other end to pin 9 of V5 (NS). Dress this lead close to the chassis.
- (✓) Prepare a 17" length of GREEN hookup wire and connect one end to DD5 (NS). Dress this lead as shown in Pictorial 3 and connect the other end to screw terminal strip LL1 (S-2).
- (✓) Prepare a 2" length of GREEN hookup wire and connect one end to DD6 (NS). Dress the lead close to the chassis and connect the other end to pin 9 of V6 (NS).
- (✓) Prepare an 8" length of BLUE hookup wire and connect one end to terminal strip GG1 (NS). Dress this lead close to the chassis as shown in Pictorial 3 and connect to pin 2 of V10 (NS).
- (✓) Prepare a 7" length of BLUE hookup wire and connect one end to GG2 (NS). Dress this lead close to the chassis as shown in Pictorial 3 and connect to pin 2 of V9 (NS).
- (✓) Prepare a 2 1/2" length of GREEN hookup wire and connect one end to pin 3 of V7 (S-1). Dress this lead close to the chassis as shown in Pictorial 3 and connect to pin 3 of V8 (NS).
- (✓) Prepare a 3" length of GREEN hookup wire and connect one end to pin 3 of V8 (NS). Dress this lead close to the chassis and connect to pin 3 of V10 (NS).
- (✓) Prepare a 10" length of GREEN hookup wire and connect one end to GG3 (NS). Dress this lead close to the chassis as shown in Pictorial 3 and connect to pin 2 of V8 (NS).
- (✓) Prepare an 8 1/2" length of GREEN hookup wire and connect one end to GG4 (NS). Dress this lead close to the chassis as shown in Pictorial 3 and connect the other end to pin 2 of V7 (NS).
- (✓) Prepare a 2 1/2" length of BLUE hookup wire and connect to pin 3 of V10 (S-2). Dress this lead close to the chassis as shown in Pictorial 3 and connect to pin 3 of V9 (NS).
- (✓) Prepare a 2 3/4" length of BLACK hookup wire and connect one end to lug 4 of screw terminal strip LL (NS). Dress this lead under the slide switch and connect to J6 (NS).
- (✓) Prepare a 5" length of BLACK hookup wire and connect one end to I.A (S-3). Connect the other end to KK1 (NS).
- (✓) Prepare a 4 1/2" length of BLACK hookup wire and connect one end to KK2 (NS). Dress the other end close to the chassis toward the large cutout in the chassis. Leave it to be connected later.
- (✓) Prepare a 1 1/2" length of BLACK hookup wire and connect one end to J6 (S-3). Connect the other end to J1 (S-1).
- (✓) Prepare the short length of heavy stranded wire supplied in the parts list, and a #6 spade lug as shown in Detail 3A.

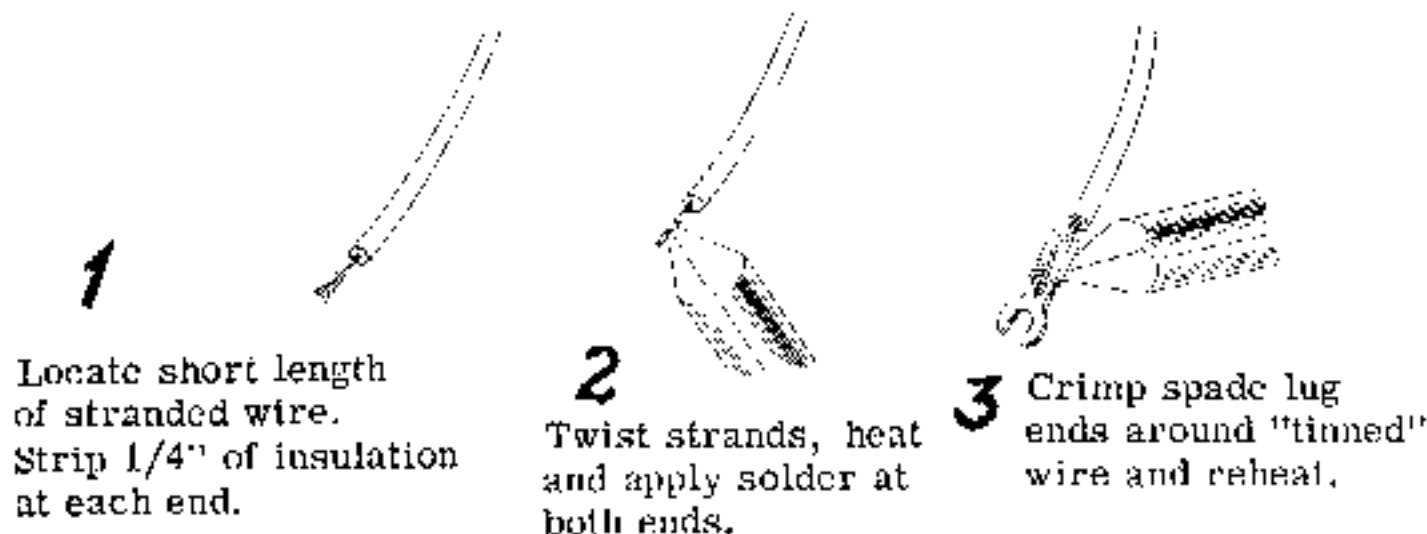

Detail 3A

- (/) Insert the tinned end through the hole beneath MM4 from the outside edge of the chassis. Connect this lead to J3 (NS).
- (/) Prepare a 1 1/2" length of BLUE hookup wire and connect one end to J3 (S-2). Connect the other end to J4 (S-1).
- (/) Prepare a 2" length of BLUE hookup wire and connect one end to lug 2 of switch J (S-1). Connect the other end to MM1 (S-1).
- (/) Prepare a 2 1/2" length of BLACK hookup wire and connect one end to J5 (S-1). Connect the other end to MM2 (S-1).
- () Prepare a 24" length of GREEN and a 24" length of BLACK hookup wire. Twist the two wires together their full length to form a twisted pair.
- (/) Dress one end under the fuse holder (F) and one AC receptacle (G). Connect the GREEN wire from this end to G1 (NS) and the BLACK wire from the same end to H2 (NS).
- (/) Refer to Pictorial 3 and dress the twisted pair along the inside corner of the chassis up to and through the rubber grommet at C. Leave the ends to be connected later.
- (/) Prepare a 14 1/2" length of BLACK hookup wire, dress one end under the fuse holder and connect to G2 (NS).
- (/) Prepare a 13" length of BLUE hookup wire and connect one end to F2 (S-2).
- (/) Twist the BLACK and BLUE wires together and dress this pair along the twisted pair previously installed.
- (/) Connect the BLACK wire to EE3 (NS), and the BLUE wire to EE1 (NS).
- (/) Prepare a 2 3/4" length of BLACK hookup wire and connect one end to H1 (S-1). Dress this lead under the two AC receptacles and connect to G2 (NS).
- (/) Prepare a 5" length of BLACK hookup wire and connect one end to H2 (S-2). Dress this lead under the G receptacle and connect to F1 (S-1).
- (/) Locate the 4-section filter capacitor (#25-93). Note the insulating wafer separating the lugs. Three of the four lugs show a symbol between the lug and outer case. Install the capacitor into wafer D from the top of the chassis and position the symbols as shown in Pictorial 3. Holding the capacitor firmly seated in the wafer, twist the four ground lugs one-eighth turn in the slot with pliers. Make sure the lugs are not touching the chassis.
- (/) Identify the heavy bare wire supplied in your kit. Although it is not necessary, you will have a neater wiring job if each end of the wire is gripped with pliers and an attempt to stretch the wire is performed. This operation will smooth out all the kinks and bends in the wire.
- (/) Refer to Pictorial 3 and insert the wire through DD4 (NS), through the center hole in FF, then bend the end toward the chassis through ground lug 1 of capacitor D (S-1). Now solder the wire at FF (S-1).
- (/) Bend a 90° angle to the left in the wire just above grommet C. Refer to Pictorial 3 and slip a 2-lug terminal strip over the end and mount at location CC (NS), using one 6-32 screw, 2 lockwashers as before, and one nut.
- (/) Refer to Pictorial 3 and bend another 90° angle toward the inside of the chassis 4 1/4" from terminal strip CC1.

- (✓) Slide a 4-lug terminal strip over the end of the heavy bare wire and position as in Pictorial 3 at location EB (NS). Mount EB using a 6-32 x 1/4" screw, two lockwashers, and one nut.
- (✓) Draw the heavy bare wire through BB1 except for about 3/16" from the bend. Press the wire down to the bottom of the solder lug with a screwdriver and apply a small amount of solder to hold it in place. DO NOT fill the slot in the lug with solder for there must be room to connect additional wires.
- (✓) Cut the heavy bare wire 3 1/2" from BB1 and leave it to be connected later.
- (✓) Prepare a 3 1/2" length of BLUE hookup wire and connect one end to lug 3 of terminal strip BB (NS). Dress the other end through the hole in the chassis located directly under this lug and leave it to be connected later.
- (✓) Prepare a 6 1/4" length of RED hookup wire and connect one end to CC2 (NS). Connect the other end to JJ2 (NS). Dress this lead as in Pictorial 3.
- (✓) Prepare a 6 1/2" length of RED hookup wire and connect one end to HH1 (S-3). Dress this lead as shown in Pictorial 3 and connect the other end to the ▲ lug at D (NS).
- (✓) Prepare a 6 1/4" length of RED hookup wire and connect one end to terminal strip JJ1 (NS). Dress this wire as shown in Pictorial 3 and connect the end to lug 5 of filter capacitor D (NS).
- (✓) Prepare a 4 1/2" length of RED hookup wire and connect one end to JJ2 (NS). Dress the other end as shown in Pictorial 3 and connect to the ▲ lug at D (NS).
- (✓) Prepare a 7" length of RED hookup wire and connect one end to DD3 (NS). Dress the other end as shown in Pictorial 3 and connect to the ■ lug at D (NS).
- (✓) Prepare a 3" length of RED hookup wire and connect one end to DD3 (NS). Connect the other end to DD7 (NS).
- (✓) Connect the RED-YELLOW lead from the power transformer (#54-93) to D3 (S-1).
- (✓) Prepare a 1 1/2" length of RED hookup wire and connect one end to pin 8 of V11 (S-2). Connect the other end to the ▲ lug at D (NS).
- (✓) Prepare a 2 1/2" length of BLACK hookup wire and connect one end to control B2 (S-1). Connect the other end to control A2 (NS).
- (✓) Prepare a 4" length of BLACK hookup wire and connect one end to A2 (NS). Dress the other end as shown in Pictorial 3 and connect this end to DD4 (NS).

COMPONENT WIRING, MAIN CHASSIS

- (✓) Identify a 10 μ fd 25 V filter capacitor and a 2.7 K Ω resistor (RED-VIOLET-RED) and prepare as in Detail 4A. Note the plus (+) and minus (-) marking on the body of the capacitor.
- (✓) Use sleeving on both leads of the capacitor and position to the left and close to V1, as shown in Pictorial 4. Connect the + lead to pin 3 of V1 (S-1), and the - lead to BB1 (NS).

Detail 4A

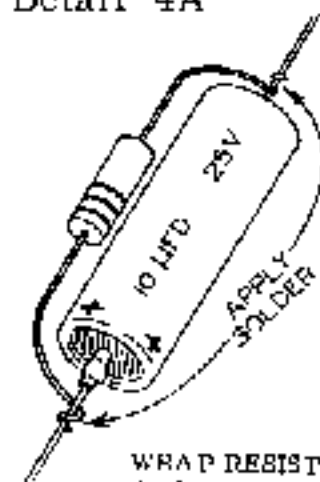

WRAP RESISTOR LEAD AROUND CAPACITOR LEAD. AVOID PLACING LEAD OVER CRUMPLED PORTION OF CAPACITOR.

- (✓) Trim the band lead of a .1 μ fd 200 V capacitor to 1 1/2" and slip 1 1/4" of sleeving over this lead. Trim the opposite lead to 1 1/4" and slip 1" length of sleeving over this lead.
- (✓) Connect the band lead to pin 1 of V2 (S-2). Position the body of the capacitor close to the chassis as shown in Pictorial 4. Connect the opposite end to BB2 (NS).
- (✓) Trim both leads of a 470 K Ω resistor (YELLOW-VIOLET-YELLOW) to a length of 5/16". Connect this resistor between BB2 (S-2) and BB3 (NS).
- (✓) Trim both leads of a 22 K Ω resistor (RED-RED-ORANGE) to 5/16" and connect between BB3 (NS) and BB4 (NS).
- (✓) Trim both leads of a .0035 μ fd disc capacitor to 5/16" and connect between BB3 (S-4) and BB4 (NS). Position as shown in Pictorial 4. Be certain all four leads at BB3 are well covered with solder.
- (✓) Trim both leads of a .01 μ fd 50 V disc capacitor to 5/8" and connect between BB4 (S-3) and the heavy bare wire (S-1).
- (✓) Prepare a 10 μ fd 25 V capacitor and a 2.7 K Ω resistor (RED-VIOLET-RED) as in Detail 4A. Trim the + lead of the capacitor to a length of 1 1/4". Place a 1" length of sleeving over the + lead and connect to pin 3 of V2 (S-1).
- (✓) Position the capacitor as in Pictorial 4 and connect the - lead to lug 1 of BB (S-6). Be certain solder has flowed over all six leads at BB1.
- (✓) Trim the band end of a .022 μ fd 400 V capacitor to a length of 2" and place a 1 3/4" length of sleeving over it. Place 1 1/4" of sleeving over the other lead.
- (✓) Position the capacitor as in Pictorial 4 and connect the band end to pin 6 of V2 (S-2). Dress the other end through the hole in the chassis near the .022 μ fd capacitor previously installed.
- (✓) Trim one lead of a 1 megohm resistor (BROWN-BLACK-GREEN) to a 5/16" length and place a 1" length of sleeving over the other lead. Connect the 5/16" lead to pin 7 of V2 (NS), position the body of the resistor as in Pictorial 4 and connect the longer lead to the heavy bare wire (S-1).
- (✓) Prepare a 10 μ fd 25 V capacitor and 1.2 K Ω resistor (BROWN-RED-RED) as shown in Detail 4A. Trim the + lead to a length of 1 3/4" and slip a 1 1/2" length of sleeving over this end.
- (✓) Place the capacitor as shown in Pictorial 4 and connect the + lead to pin 8 of V2 (S-1). Connect the - lead to the heavy bare wire (S-1).
- (✓) Prepare a .0035 μ fd disc capacitor and a 3.3 K Ω resistor (ORANGE-ORANGE-RED) as shown in Detail 4B.
- (✓) Insert one lead through pin 2 of V4 (S-1) and connect it to pin 7 of V4 (S-1). Dress the other lead toward the large cutout in the chassis. Refer to Pictorial 4.
- (✓) Prepare a .0035 μ fd disc capacitor and a 3.3 K Ω resistor (ORANGE-ORANGE-RED) as shown in Detail 4B.
- (✓) Insert one lead through pin 2 of V3 (S-1) and connect to pin 7 of V3 (S-1). Dress the capacitor as in Pictorial 4 and connect the other lead to the heavy bare wire (S-1).



Detail 4B

- (✓) Trim both leads of a .1 μ fd 200 V capacitor to a length of 1 1/4" and connect the band end to CC1 (S-2). Connect the other end to pin 6 of V3 (NS). Position as shown in Pictorial 4.
- (✓) Trim one end of a 120 K Ω resistor (BROWN-RED-YELLOW) to a length of 7/8" and the other end to 1/2". Position as shown in Pictorial 4 and connect the 7/8" end to pin 6 of V3 (S-2). Connect the 1/2" end to CC2 (NS).
- (✓) Trim one end of a 120 K Ω resistor (BROWN-RED-YELLOW) to a length of 7/8" and connect to CC2 (S-3).
- (✓) Place 1 1/4" of sleeving over the other end and connect to pin 6 of V4 (NS).
- (✓) Trim the band end of a .1 μ fd 200 V capacitor to a length of 1/2" and connect to the heavy bare wire (S-4).
- (✓) Place 1 3/4" of sleeving over the other lead and connect to pin 6 of V4 (S-2).
- (✓) Locate six 100 K Ω resistors (BROWN-BLACK-YELLOW) and trim ONE end of each to a length of 1/2". The six prepared resistors will be used in the following six steps. Refer to Pictorial 4 for proper positioning before installing each resistor.
- (✓) Trim the longer lead of a prepared resistor to a length of 1/2" and connect between JJ1 (NS) and HH3 (S-2).
- (✓) Trim the longer lead of a prepared resistor to a length of 1" and connect between JJ1 (NS) and HH2 (S-2).
- (✓) Trim the longer lead of a prepared resistor to a length of 1/2" and connect between HH4 (S-2) and JJ1 (NS).
- (✓) Trim the longer lead of a prepared resistor to a length of 1/2" and connect between JJ1 (S-5) and HH5 (S-2). Be certain all five leads are well covered with solder.
- (✓) Trim the longer lead of a prepared resistor to a length of 1/2" and connect between JJ2 (NS) and HH6 (S-2).
- (✓) Trim the longer lead of a prepared resistor to a length of 1/2" and connect between JJ2 (S-4) and HH7 (S-2).
- (✓) Trim both leads of a .05 μ fd 400 V capacitor to a length of 3/4" and connect the band end to pin 1 of V5 (NS). Refer to Pictorial 5.

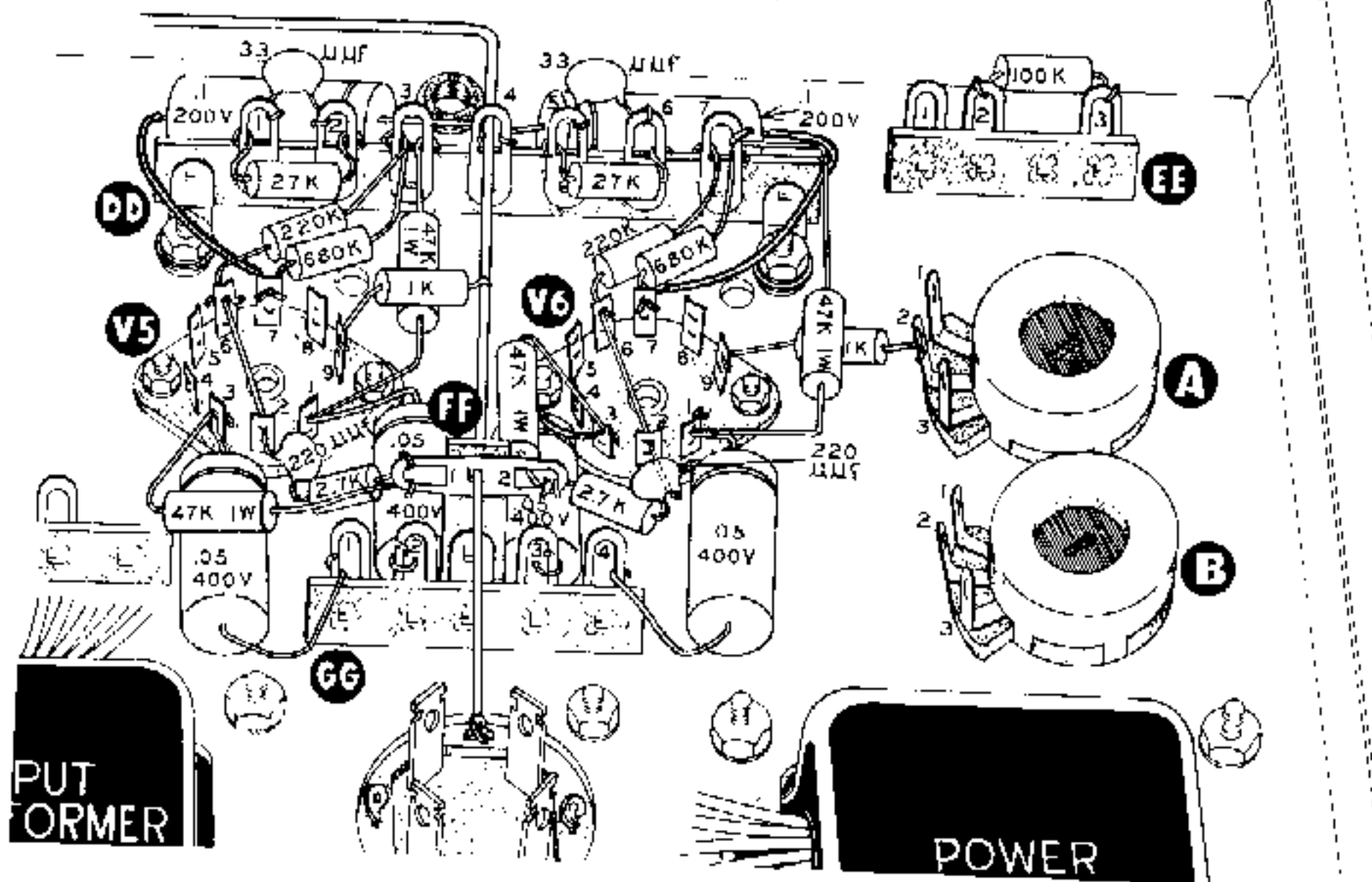

Pictorial 5

- (✓) Position the capacitor as in Pictorial 5 and connect the other lead to GG2 (S-2).
- (✓) Trim the band end of a .05 μ f 400 V capacitor to a length of 1/2" and the opposite lead to 1". Position as shown in Pictorial 5 and connect the band lead to pin 3 of V5 (NS). Connect the other lead to GG1 (S-4).
- (✓) Prepare a 220 μ f disc capacitor and 2.7 K Ω resistor (RED-VIOLET-RED) as shown in Detail 5A. Refer to Pictorial 5 for proper positioning and connect the resistor lead to FF1 (NS).
- (✓) Place the capacitor lead through pin 2 of V5 (S-1) and connect to pin 6 of V5 (NS).
- (✓) Trim one lead of a 1 watt 47 K Ω resistor (YELLOW-VIOLET-ORANGE) to a length of 1" and the other lead to 3/4". Refer to Pictorial 5. Connect the 3/4" lead to FF1 (S-2) and the 1" lead to pin 3 of V5 (S-2).
- (✓) Trim one lead of a 1 watt, 47 K Ω resistor (YELLOW-VIOLET-ORANGE) to a length of 1" and the other lead to 3/4". Refer to Pictorial 5. Connect the 1" lead to pin 1 of V5 (S-2) and the 3/4" lead to DD3 (NS).
- (✓) Trim one lead of a 1 K Ω resistor (BROWN-BLACK-RED) to a length of 5/16" and the other lead to 1/2". Connect the 5/16" lead to pin 9 of V5 (S-2) and the 1/2" lead to the heavy bare wire (S-4).
- (✓) Trim both leads of a 220 K Ω resistor (RED-RED-YELLOW) to a length of 3/4". Refer to Pictorial 5 and connect one lead to pin 6 of V5 (S-2) and the other lead to DD3 (NS).
- (✓) Trim one lead of a 680 K Ω resistor (BLUE-GRAY-YELLOW) to a length of 3/8" and the other lead to 1/2". Position as shown in Pictorial 5. Connect the 3/8" lead to pin 7 of V5 (NS) and the 1/2" lead to DD3 (S-5).

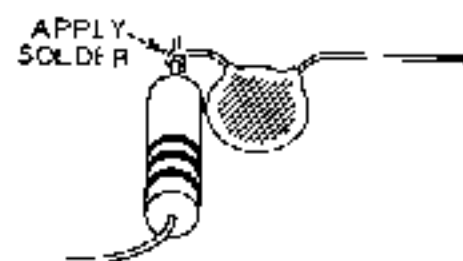

Detail 5A

- (✓) Trim the band lead of a .1 μ fd 200 V capacitor to 3/4" and slip 1 5/8" sleeving over the other lead. Position as shown in Pictorial 5 and connect the 3/4" banded lead to DD4 (NS). Connect the other lead to pin 7 of V5 (S-2).
- (✓) Trim both leads of a 27 K Ω resistor (RED-VIOLET-ORANGE) to a length of 3/8" and connect between DD1 (NS) and DD2 (NS).
- (✓) Trim both leads of a 33 μ fd disc capacitor to a length of 5/16". Connect between DD1 (S-3) and DD2 (S-3).
- (✓) Trim the band end of a .05 μ fd 400 V capacitor to a length of 1 1/4" and the other end to 1/2". Slip a 1" length of sleeving over the 1 1/4" lead and position as shown in Pictorial 5. Connect the 1/2" lead to GG3 (S-2).
- (✓) Bend the 1 1/4" lead (on the end with the band) over the body of the capacitor as shown in Pictorial 5 and connect to pin 3 of V6 (NS).
- (✓) Trim the band end of a .05 μ fd 400 V capacitor to a length of 1/2" and the other lead to 1". Position as shown in Pictorial 5. Connect the band lead to pin 1 of V6 (NS) and the 1" lead to GG4 (S-2).
- (✓) Prepare a 220 μ fd disc capacitor and 2.7 K Ω resistor (RED-VIOLET-RED) as shown in Detail 5A. Refer to Pictorial 5 and connect the resistor lead to FF2 (NS).
- (✓) Place the capacitor lead through pin 2 of V6 (S-1) and connect to pin 6 of V6 (NS).
- (✓) Trim one end of a 1 watt 47 K Ω resistor (YELLOW-VIOLET-ORANGE) to a length of 3/8" and the other lead to 3/4". Positioning as shown in Pictorial 5, connect the 3/8" lead to FF2 (S-2) and the 3/4" lead to pin 3 of V6 (S-2).
- (✓) Trim both leads of a 1 K Ω resistor (BROWN-BLACK-RED) to a length of 1/2" and connect between pin 9 of V6 (S-2) and lug 2 of control A (S-8).
- (✓) Trim one lead of a 1 watt 47 K Ω resistor (YELLOW-VIOLET-ORANGE) to a length of 3/4" and the other lead to 1 1/2".
- (✓) Refer to Pictorial 5 and connect the 3/4" lead to pin 1 of V6 (S-2) and the 1 1/2" lead to DD7 (NS).
- (✓) Trim both leads of a 220 K Ω resistor (RED-RED-YELLOW) to a length of 1/2". Connect one lead to pin 6 of V6 (S-2) and the other lead to DD7 (NS).
- (✓) Trim both ends of a 680 K Ω resistor (BLUE-GRAY-YELLOW) to a length of 1/2" and connect between DD7 (S-4) and pin 7 of V6 (NS).
- (✓) Trim the band end of a .1 μ fd 200 V capacitor to a length of 1". Slip a 1 1/4" length of sleeving over the other lead.
- (✓) Position the capacitor as shown in Pictorial 5. Connect the band end to DD4 (S-4) and the other lead to pin 7 of V6 (S-2).
- (✓) Trim both leads of a 27 K Ω resistor (RED-VIOLET-ORANGE) to a length of 3/8" and connect between DD5 (NS) and DD6 (NS).
- (✓) Trim both leads of a 33 μ fd disc capacitor to a length of 3/8" and connect between DD5 (S-3) and DD6 (S-3).

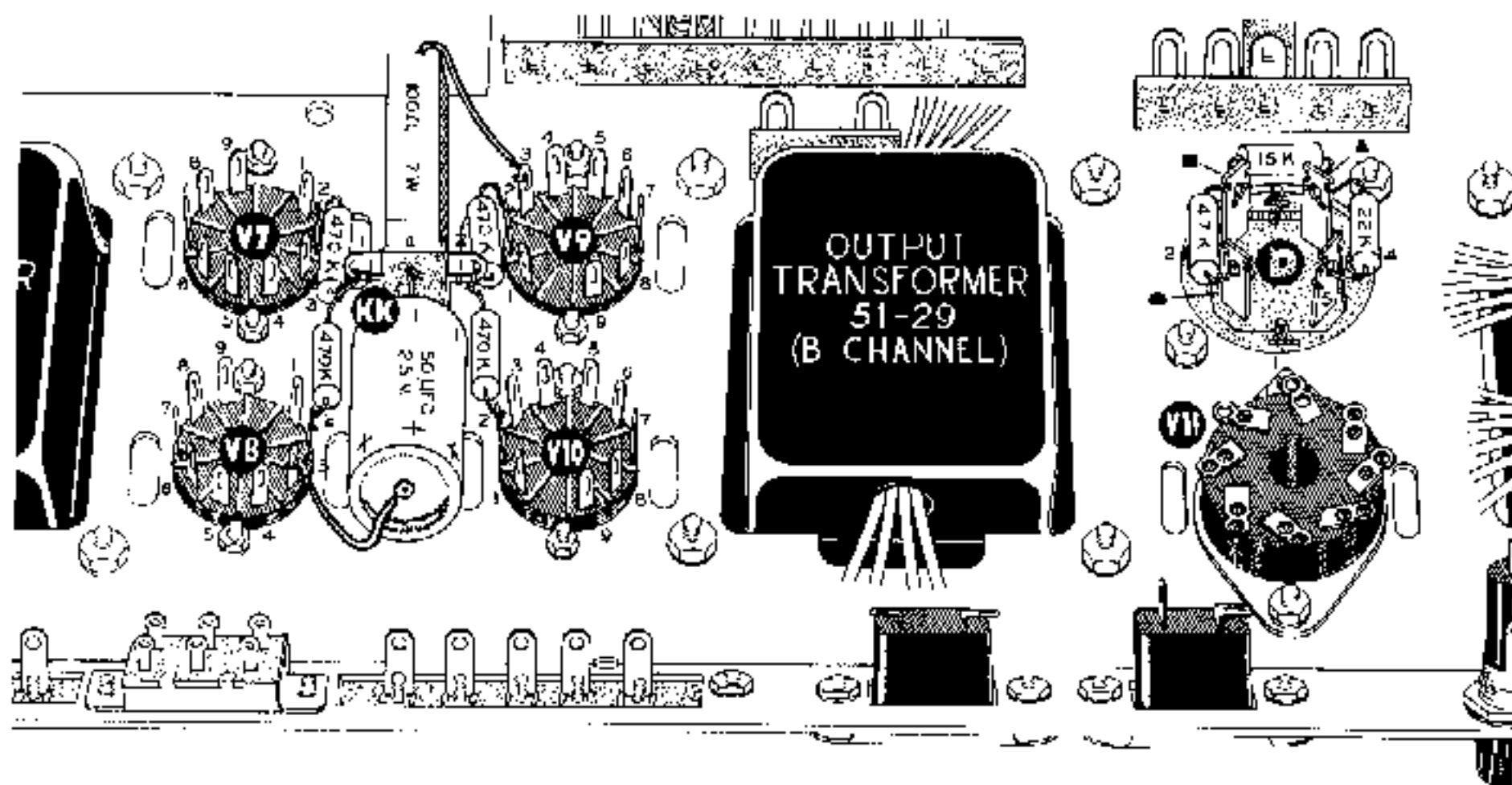

Pictorial 6

- (✓) Locate four 470 K Ω resistors (YELLOW-VIOLET-YELLOW) and trim ONE lead of each to a length of 5/8" and bend to a right angle to the resistor body. Refer to Pictorial 6 for proper positioning before completing the installation of these four prepared resistors.
- (✓) Trim the longer lead of a prepared resistor to a length of 3/4" and connect between pin 2 of V8 (S-2) and KK1 (NS).
- (✓) Trim the longer lead of a prepared resistor to a length of 3/4" and connect between pin 2 of V10 (S-2) and KK2 (NS).
- (✓) Trim the longer lead of a prepared resistor to a length of 5/8" and connect between KK1 (S-3) and pin 2 of V7 (S-2).
- (✓) Trim the longer lead of a prepared resistor to a length of 5/8" and connect between KK2 (S-3) and pin 2 of V9 (S-2).
- (✓) Trim one lead of a 100 Ω , 7 watt resistor to a length of 1/2" and the other lead to 1 1/4". Slip a 1" length of sleeving over the 1 1/4" lead.
- (✓) Connect the 1/2" lead to the center insulated hole of terminal strip KK (NS). Refer to Pictorial 6. Connect the 1 1/4" lead to pin 3 of V9 (S-2).
- (✓) Trim the - lead of a 50 μ f 25 V capacitor to a length of 3/8" and the + lead to 1". Slip a 3/4" length of sleeving over the 1" lead.
- (✓) Connect the - lead to the center insulated hole of terminal strip KK (S-2). Connect the + lead to pin 3 of V8 (S-3).
- (✓) Trim both leads of a 100 K Ω resistor (BROWN-BLACK-YELLOW) to a length of 3/8". Connect between EE2 (NS) and EE3 (S-2). See Pictorial 5 on Page 29.

- (✓) Trim both leads of a 4.7 K Ω resistor (YELLOW-VIOLET-RED) to a length of 1/2". Connect between the ■ lug of D (S3) and the ■ lug of D (NS).
- (✓) Trim both leads of a 15 K Ω resistor (BROWN-GREEN-ORANGE) to a length of 1/2". Connect between the ■ lug of D (S-3) and the ▲ lug of D (NS).
- (✓) Trim both leads of a 22 K Ω resistor (RED-RED-ORANGE) to a length of 1/2" and connect between the ▲ lug of D (S3) and D5 (S2).
- (✓) Locate the input bracket, four dual phono jacks, sixteen 3-48 x 1/4" screws and sixteen 3-48 nuts.

(✓) Refer to Detail 7A and install the four phono jacks as shown, using the 3-48 hardware. No lockwashers are necessary. Mount all four input jacks before tightening the hardware, position each flat against the input bracket, then tighten the two center jacks first. Be certain the jacks remain flat and do not overlap. Recheck each screw for tightness; these are the ground points for the amplifier and must be secure to eliminate hum and noise. Bend the ground lugs to a 90° angle with the input lugs, as shown in Detail 7A.

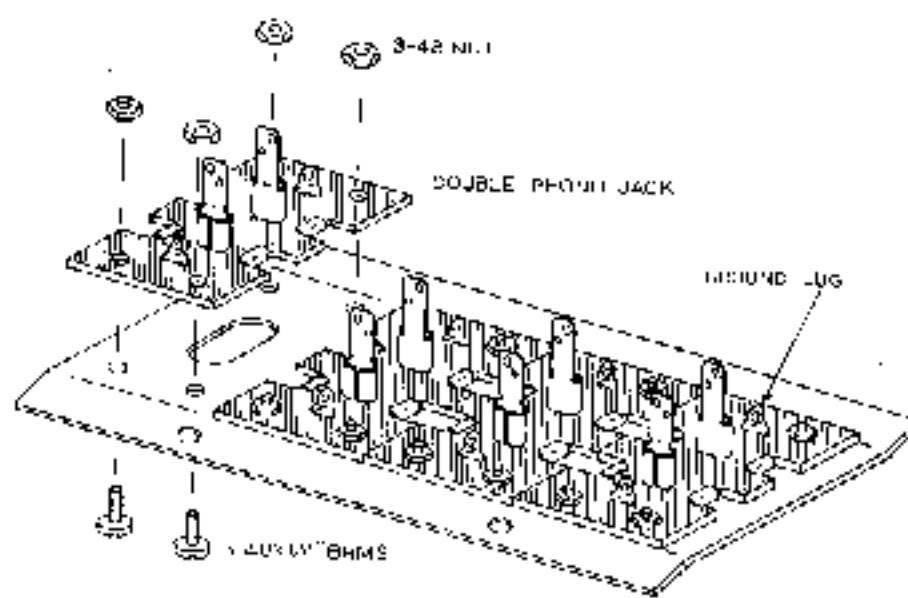

Detail 7A

- (✓) Prepare the remainder of the #14 bare wire as in Pictorial 7 and install the wire through the ground lugs. Solder the wire to all lugs.
- (✓) Select two 47 K Ω resistors (YELLOW-VIOLET-ORANGE) and trim each of the four leads to 1/2".
- (✓) Install the resistors as shown in Pictorial 7. Solder the connections to the bare wire.

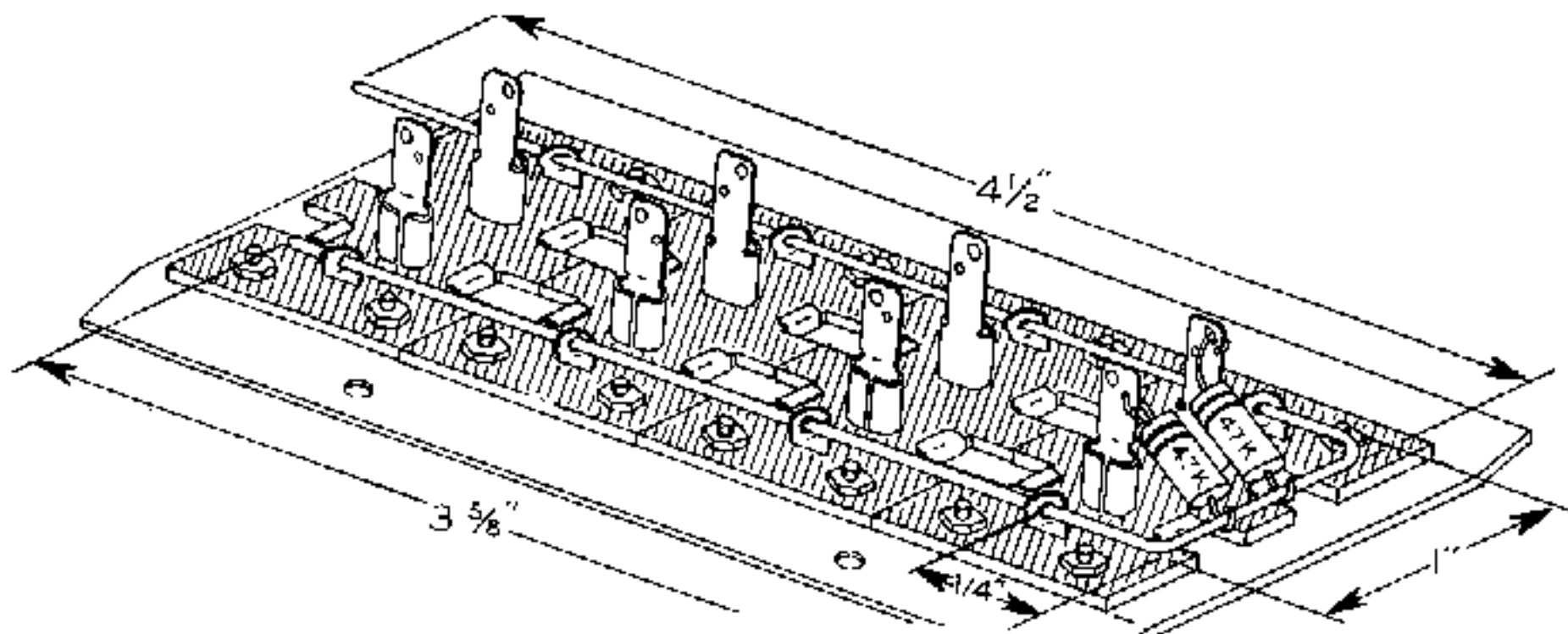

Pictorial 7

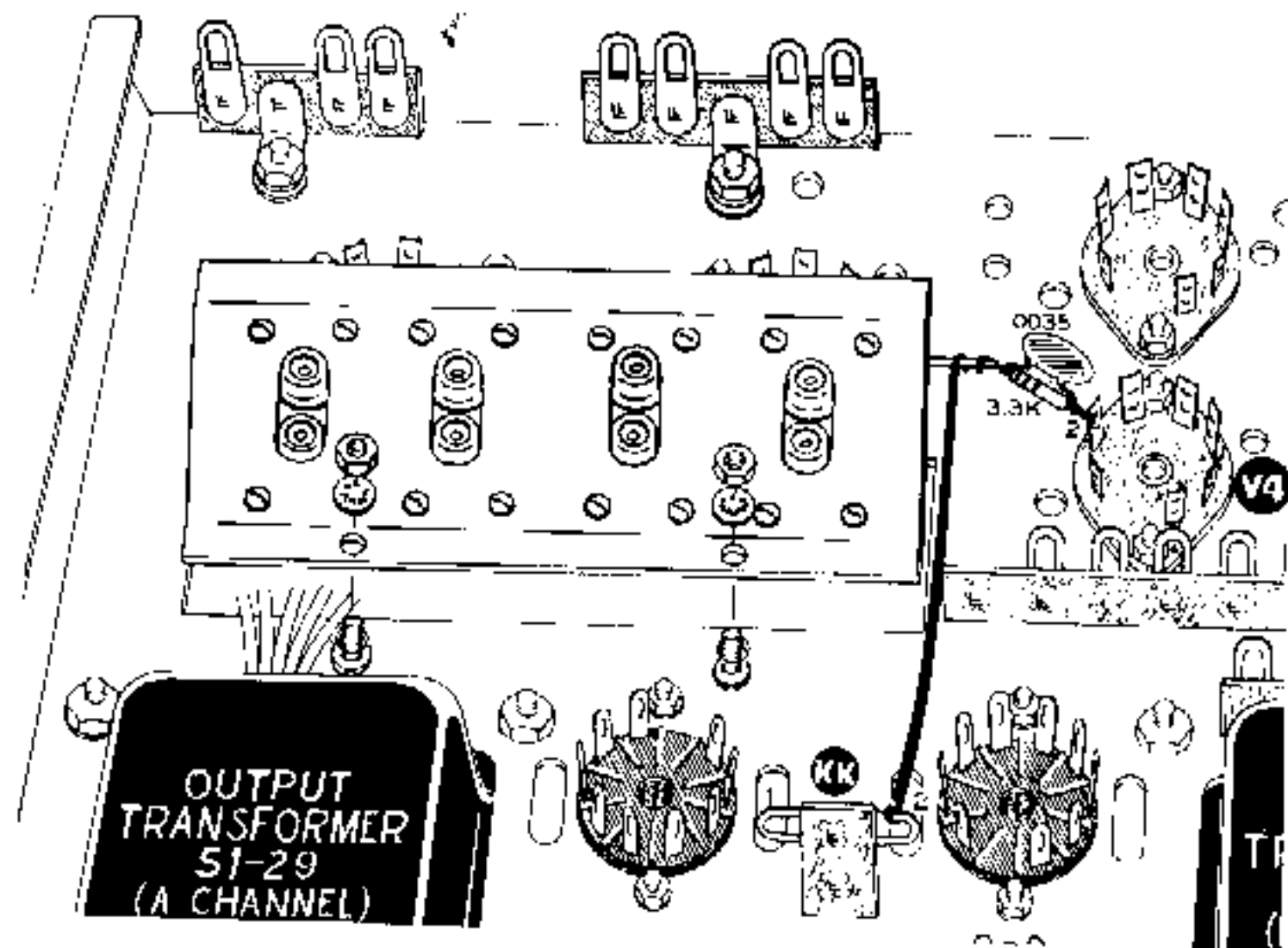

Pictorial 8

- (✓) Mount the assembly on the chassis using 6-32 x 3/8" BH machine screws, two #6 lockwashers and nuts. Refer to Pictorial 8. Firmly tighten the mounting screws. Make sure none of the wires are caught between the bracket and chassis.
- () Connect the resistor-capacitor network from pin 2 of V4 to the heavy bare wire extending from the input bracket (NS). Refer to Pictorial 8.
- (✓) Connect the BLACK lead from KK2 to the heavy bare wire extending from the input bracket (S-2).
- (✓) Turn the chassis right side up on your work area and refer to Pictorial 9 for the following steps.
- (✓) Trim the lead at the band end of a .047 μ fd 400 V capacitor to a length of 1 1/2" and place a 1 1/4" length of sleeving over it. Trim the opposite lead to 1 1/4" and place a 1" length of sleeving over it.
- (✓) Position this capacitor as in Pictorial 9 and connect the band end to NN1 (NS). Dress the other lead through the hole in the chassis and connect to pin 5 of V3 (S-2).
- (✓) Trim both leads of a .047 μ fd 400 V capacitor to a length of 1 3/4" and place a 1 1/2" length of sleeving over each end.

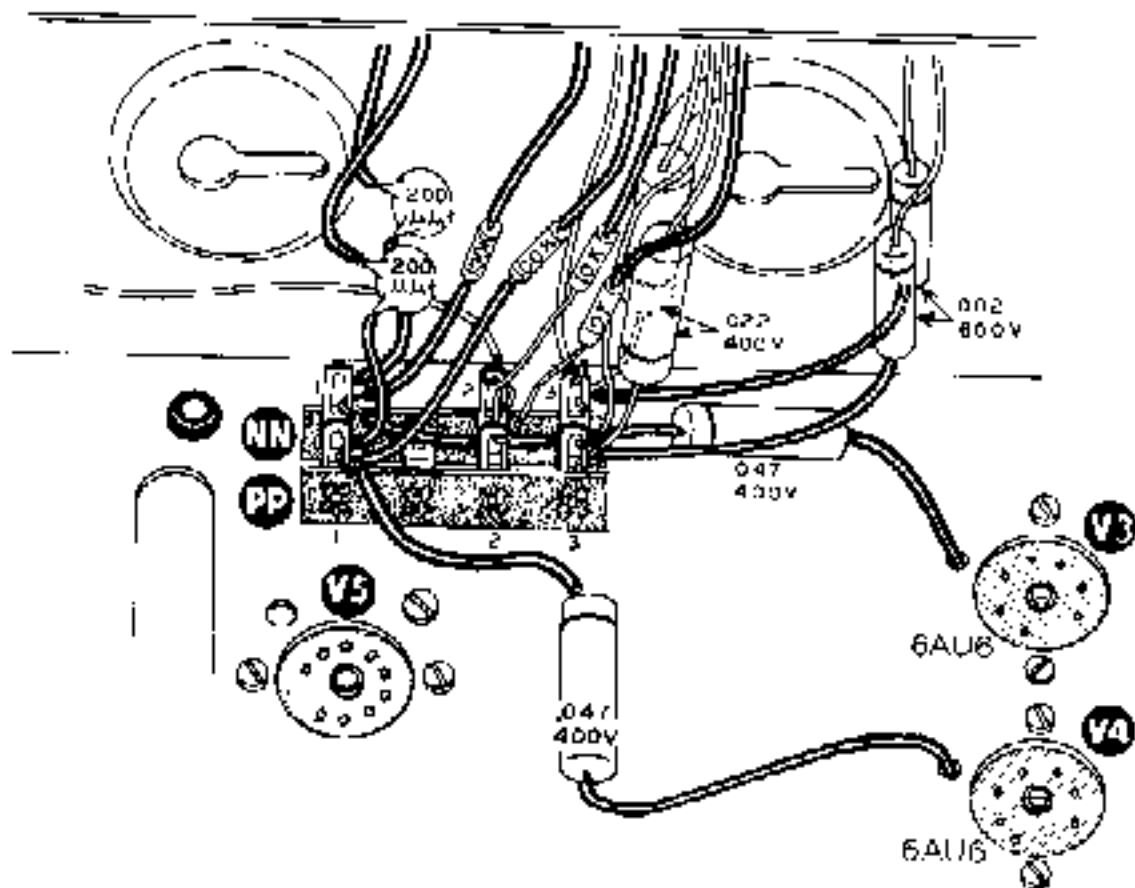

Pictorial 9

- (✓) Place the capacitor as in Pictorial 9 and connect the band end to PP1 (NS). Dress the opposite lead through the hole in the chassis and connect to pin 5 of V4 (S₂).
- (✓) Place a 1 3/4" length of sleeving over the lead opposite the band on a .002 μ fd 600 V capacitor. Connect this lead to NN3 (NS) and lay the capacitor on top of the chassis. Refer to Pictorial 9 for proper positioning.
- (✓) Place a 1 3/4" length of sleeving over the lead opposite the band on a .002 μ fd 600 V capacitor. Connect this lead to PP3 (NS) and position as the one previously installed.
- (✓) Trim the band end of two .022 μ fd 400 V capacitors to a length of 3/4". Connect this lead of one capacitor to NN3 (NS) and dress the capacitor straight up from the chassis.
- (✓) Connect the trimmed lead of the other capacitor to PP3 (NS) and dress the capacitor straight up from the chassis.
- () Prepare a GREEN and a BLUE 3 1/2" length of hookup wire by stripping the ends of 1/4" insulation.
- () Connect one end of the GREEN lead to NN3 (S₃). Dress this lead straight up from the chassis.
- (✓) Connect the BLUE lead to PP3 (S₃). Dress this lead straight up from the chassis.
- (✓) Trim one lead of a 10 K Ω resistor (BROWN-BLACK-ORANGE) to a length of 1" and connect to NN2 (NS). Dress this lead straight up from the chassis.
- (✓) Feed one uncut lead from a 10 K Ω resistor (BROWN-BLACK-ORANGE) through PP2 (S₁) and connect to NN2 (NS). Dress this resistor straight up from the chassis.
- (✓) Prepare a 4 1/2" length of BLACK hookup wire by stripping both ends of 1/4" insulation. Connect one end to NN2 (S₃). Dress this lead along the chassis as shown in Pictorial 9. Leave the other end free to be connected later.
- (✓) Slip 1 1/4" of sleeving over one lead of a 100 K Ω resistor (BROWN-BLACK-YELLOW) and connect this lead to NN1 (NS). Dress this resistor straight up from the chassis.
- () Trim one lead of a 200 μ fd disc capacitor to 1", place 3/4" of sleeving over the lead, and connect this lead to NN1 (S-3). Dress this lead straight up from the chassis as shown in Pictorial 9.
- (✓) Slip 1 1/4" of sleeving over one lead of a 100 K Ω resistor (BROWN-BLACK-YELLOW) and connect this lead to PP1 (NS). Dress this resistor straight up from the chassis.
- (✓) Trim one lead of a 200 μ fd disc capacitor to a length of 1" and slip a 3/4" length of sleeving over the lead. Connect to PP1 (S₃). Dress this lead as in Pictorial 9.
- (✓) Check the solder connections on all lugs of terminal strips NN and PP, for they will be partially hidden by a control to be installed later and defective wiring would be difficult to locate after the unit is completely assembled.

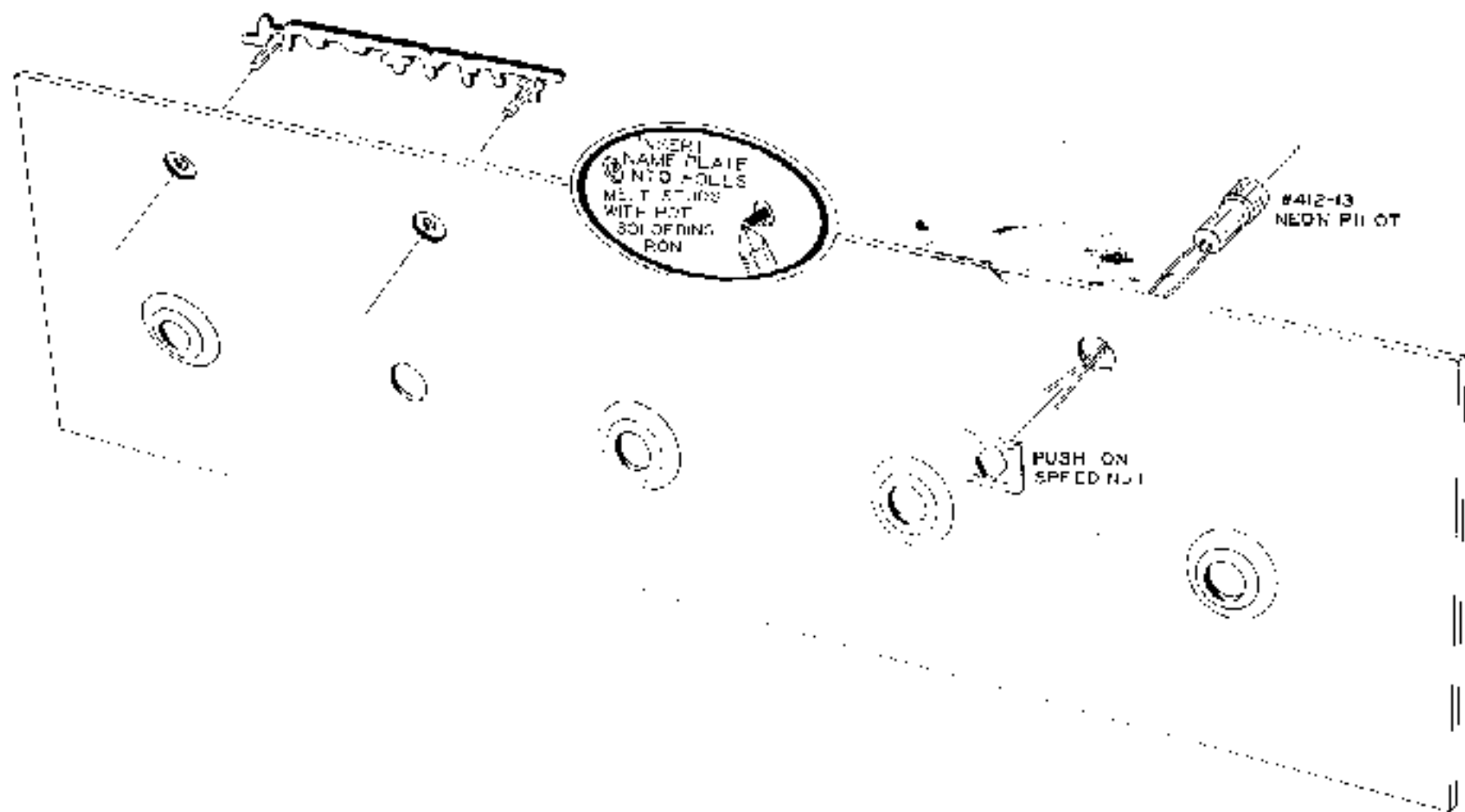

Detail 10A

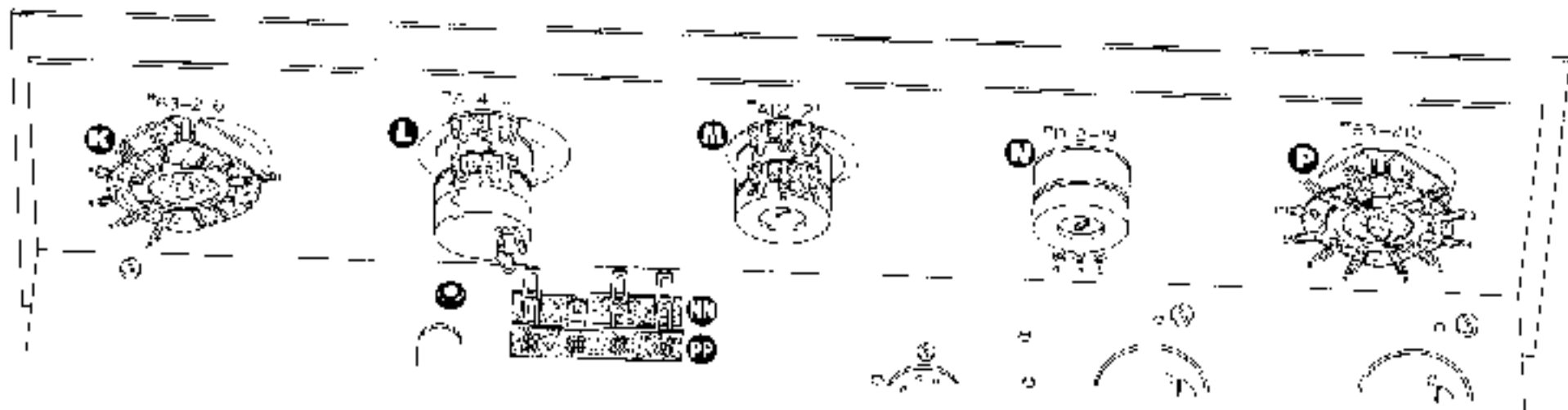

Pictorial 10

- (✓) Position the front panel as in Detail 10A and install the Heathkit logotype and neon pilot lamp as shown.
- (✓) Position the front panel on the chassis and mount the five controls as shown in Pictorial 10 and Detail 10B.
- (✓) Connect the GREEN wire of the twisted pair extending from grommet C located under control I. to L3 (S₁). Refer to Pictorial 11.
- (✓) Connect the BLACK wire of the twisted pair to I.7 (S₁).
- (✓) Slip a 1/2" length of sleeving over the lead of the 200 μ f disc capacitor from NN1; trim and connect this lead to L3 (S₁).

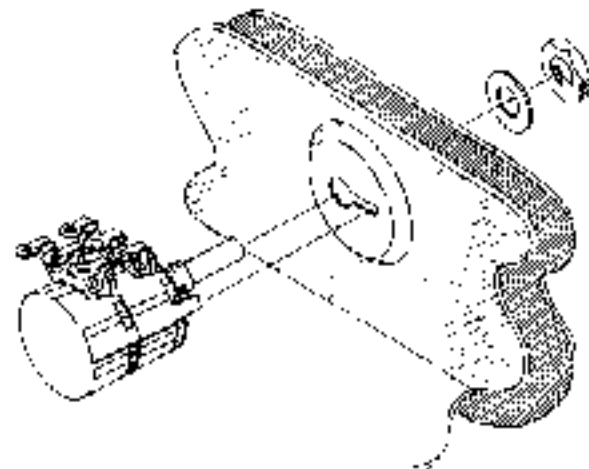

Detail 10B

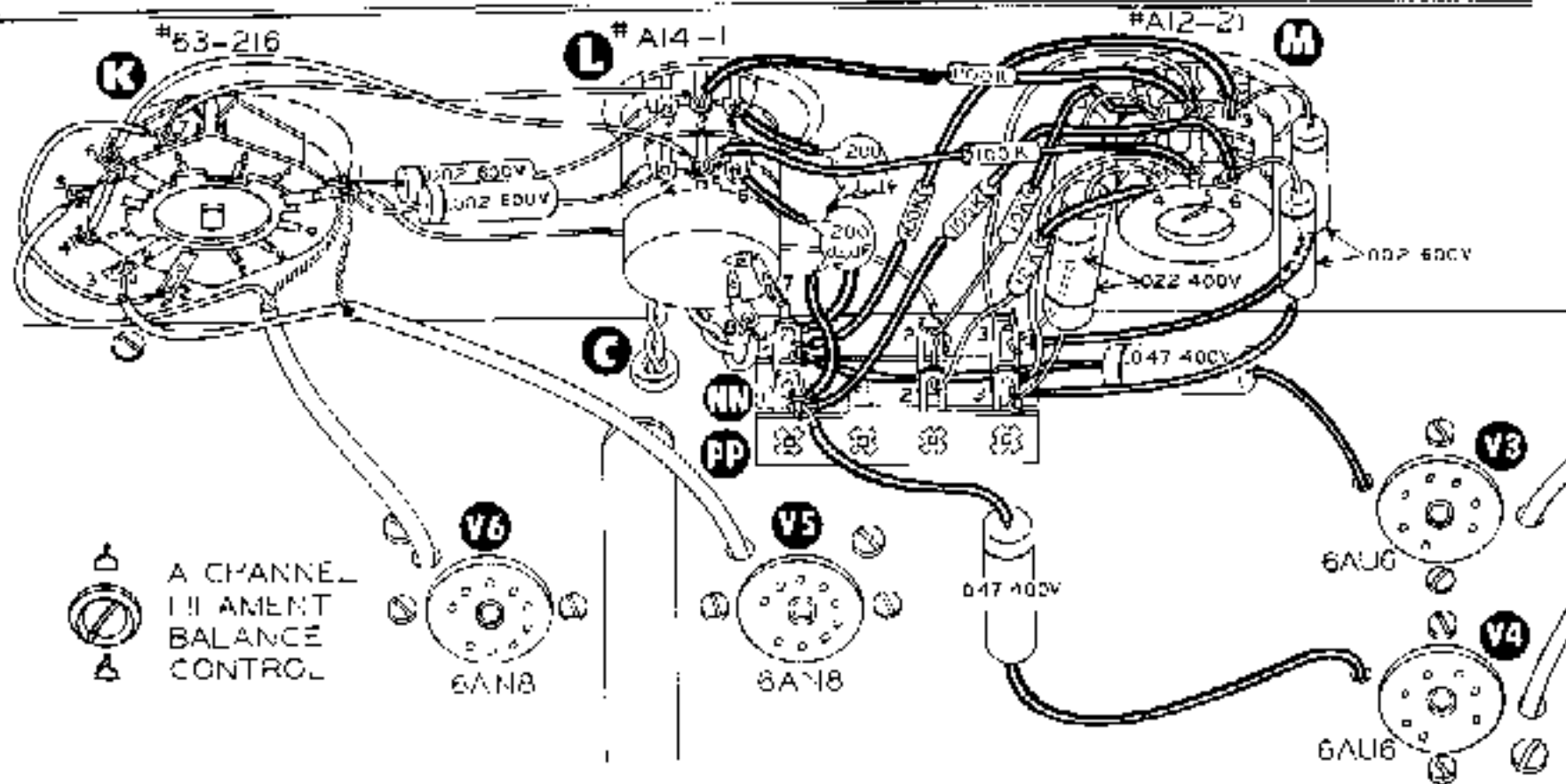

Pictorial 11

- (✓) Slip a 1/2" length of sleeving over the lead of the 200 μ f disc capacitor from PP1; trim and connect this lead to L6 (S-1). Refer to Pictorial 11.
- (✓) Trim the lead of the .022 μ f 400 V capacitor from NN3 to a length of 3/4" and connect to M1 (NS).
- (✓) Slip a 1 1/4" length of sleeving over the lead of the 10 K Ω resistor (BROWN-BLACK-ORANGE) from NN2 and connect to M1 (S-2).
- (✓) Trim the lead of the .022 μ f 400 V capacitor from PP3 to a length of 3/4" and connect to M4 (NS).
- (✓) Slip a 1 1/4" length of sleeving over the lead of the 10 K Ω resistor (BROWN-BLACK-ORANGE) from PP2 and connect to M4 (S-2).
- (✓) Connect the GREEN lead from NN3 to M2 (NS).
- (✓) Connect the BLUE lead from PP3 to M5 (NS).
- (✓) Slip a 1 1/4" length of sleeving over each lead of a 100 K Ω resistor (BROWN-BLACK-YELLOW) and connect it between M2 (S-2) and L2 (NS).
- (✓) Slip a 1 1/4" length of sleeving over each lead of a 100 K Ω resistor (BROWN-BLACK-YELLOW) and connect it between M5 (S-2) and L5 (NS).
- (✓) Slip a 1 1/4" length of sleeving over the lead of the 100 K Ω resistor (BROWN-BLACK-YELLOW) from NN1 and connect to M3 (NS).
- (✓) Slip a 1 1/4" length of sleeving over the lead of the 100 K Ω resistor (BROWN-BLACK-YELLOW) from PP1 and connect to M6 (NS).

- (✓) Trim the band lead of the .002 μ fd 600 V capacitor from NN3 to a length of 3/4" and connect to M3 (S-2).
- (✓) Trim the band lead of the .002 μ fd 600 V capacitor from PP3 to a length of 3/4" and connect to M6 (S-2).
- (✓) Connect the BLACK lead previously attached to NN2 through both lugs of K1 (NS). Do not crimp the two lugs together for there will be additional leads connected to these lugs.
- (✓) Trim both leads of a .002 μ fd 600 V capacitor to 3/4" and connect the band lead to the lug nearest the front panel at K1 (NS). Connect the other lead to L1 (S-1).
- (✓) Trim both leads of a .002 μ fd 600 V capacitor to 3/4" and connect the band end to the lug farthest from the front panel at K1 (NS). Connect the other lead to L4 (S-1).
- (✓) Refer to Detail 11A for proper stripping of the shielded lead used in the following steps.

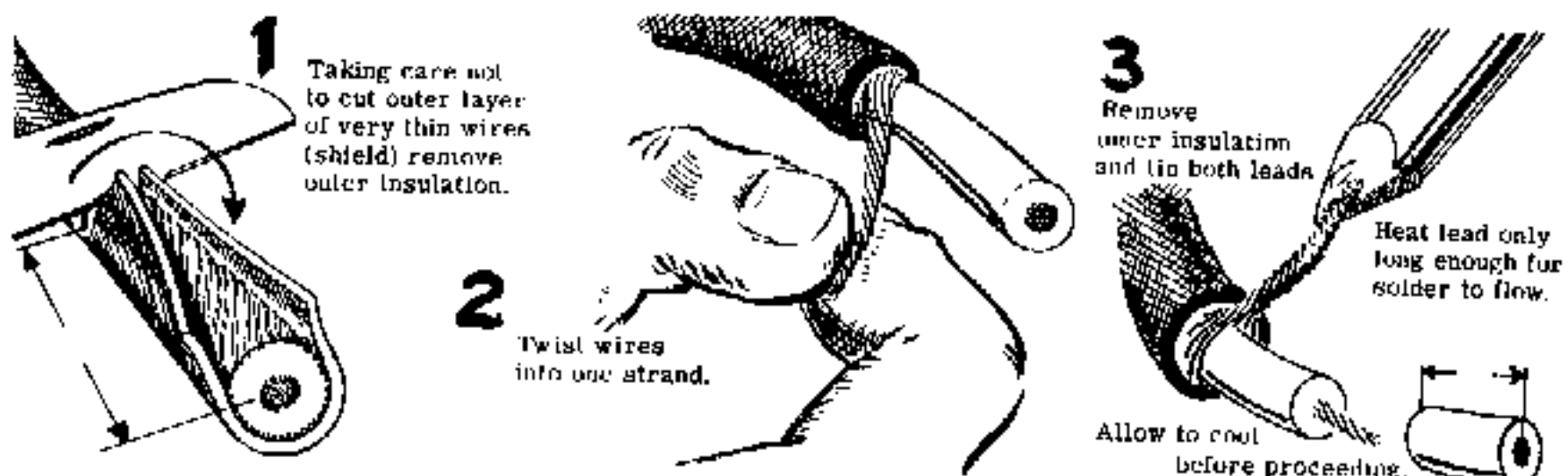

Detail 11A

- (✓) Prepare a 5" length of shielded lead as in Detail 11B.

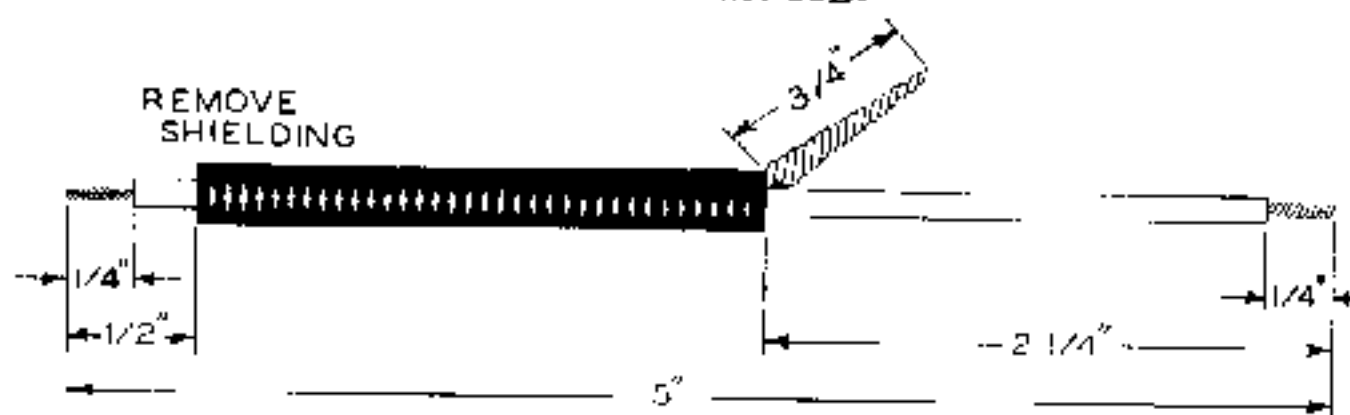

Detail 11B

- (✓) Insert the end with the shielding removed through the hole in the chassis near V6, and connect to pin 8 of V6 (S-1).
- (✓) Connect the 3/4" twisted shield lead to switch lug K1 (NS). Connect to the lug nearest the front panel.
- (✓) Dress the insulated lead under switch K and connect to K5 (S-1).

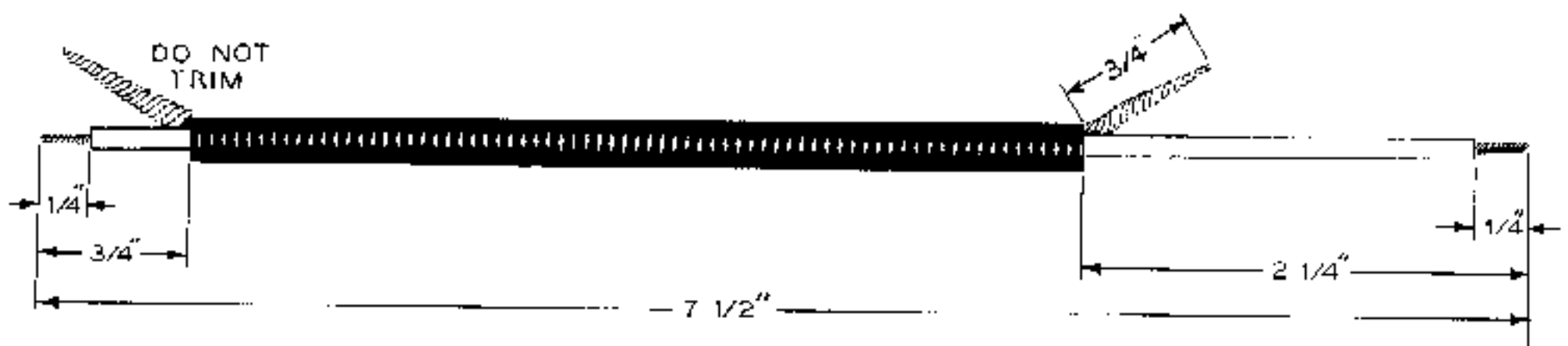

Detail 11C.

- (✓) Prepare a 7 1/2" length of shielded lead as in Detail 11C.
- (✓) Connect the longest insulated lead to K3 (S✓).
- (✓) Connect the adjacent twisted shield to the lug farthest from the front panel at K1 (S-5).
- (✓) Insert the other end through the hole near V5 and connect the insulated lead to pin 8 of V5 (S✓). Slip 1/2" of sleeving over the twisted shield and connect to the heavy bare wire (S✓).
- () Strip both ends of a 2 1/2" length of GREEN hookup wire and connect one end to K2 (S✓).
- () Connect the other end to K7 (NS).
- (✓) Strip both ends of a 3 1/2" length of GREEN hookup wire and connect one end to K7 (S-2).
- () Connect the other end to L2 (S✓).
- (✓) Strip both ends of a 4" length of BLUE hookup wire and connect one end to K6 (NS).
- (✓) Connect the other end to L5 (S✓).
- (✓) Strip both ends of a 1 1/2" length of BLUE hookup wire and connect between K6 (S-2) and K4 (S✓).
- () Prepare a shielded lead as shown in Detail 12A and one as shown in Detail 12B.

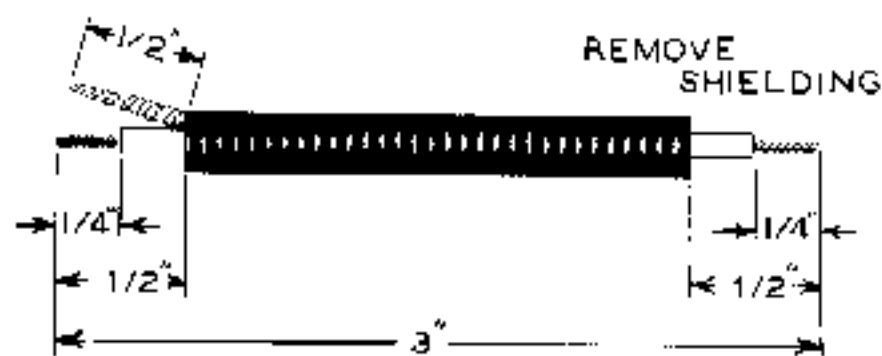

Detail 12A

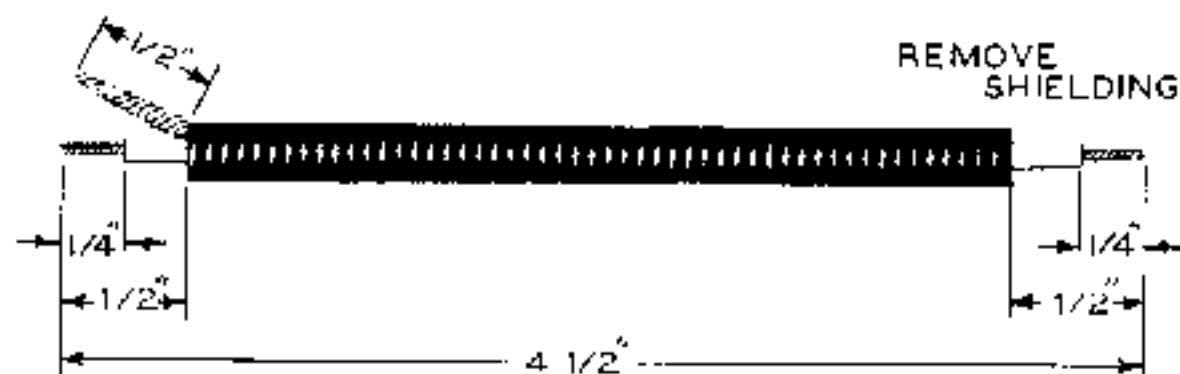

Detail 12B.

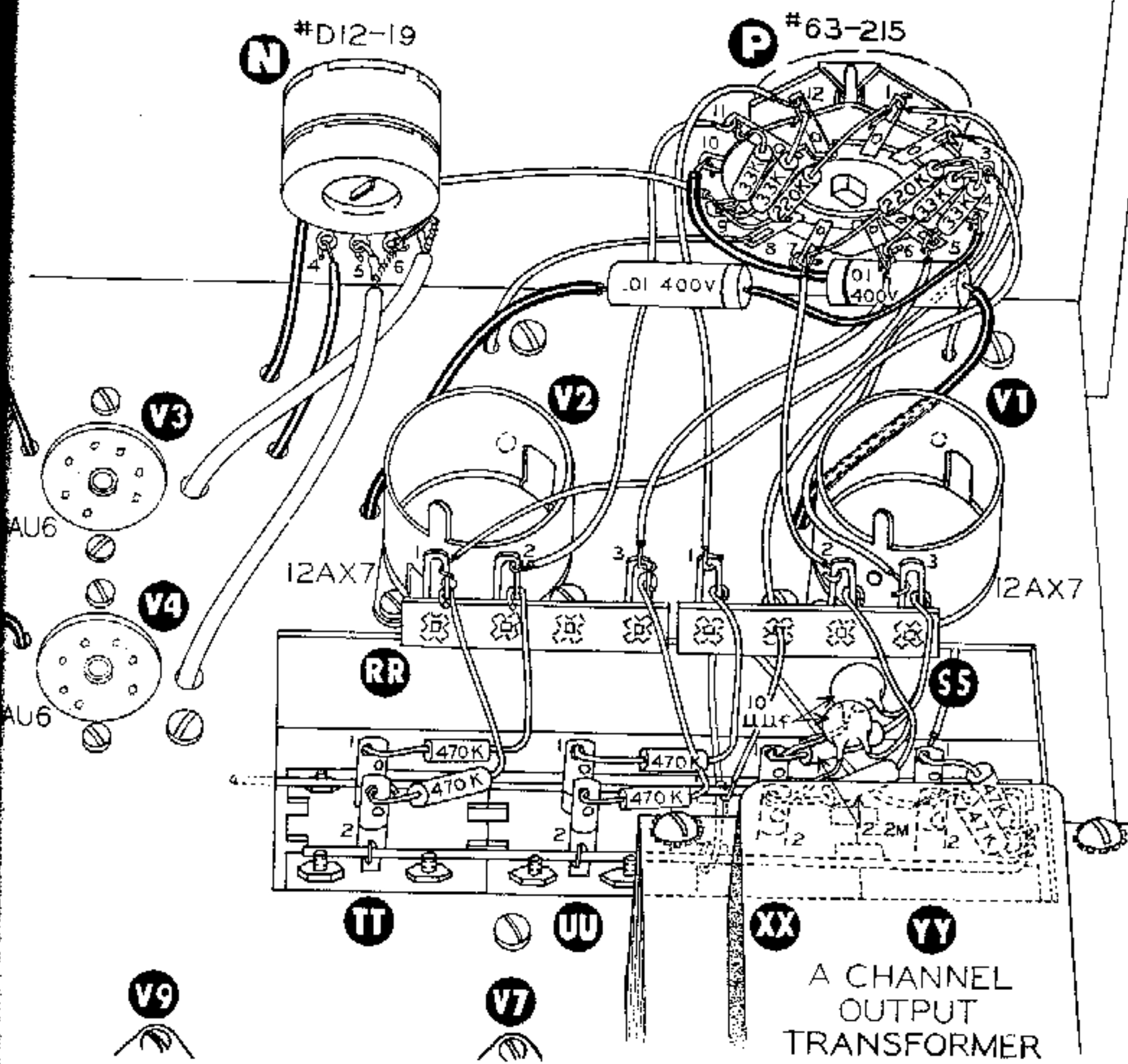

Pictorial 12

(✓) Remove the VOLUME control N from the front panel and connect the two shielded leads and a 3" prepared BLACK hookup wire as shown in Detail 12C. Connect a jumper wire between N3 and N6. Solder N2 (S-1), N3 (S-3), N5 (S-1), N6 (S-2).

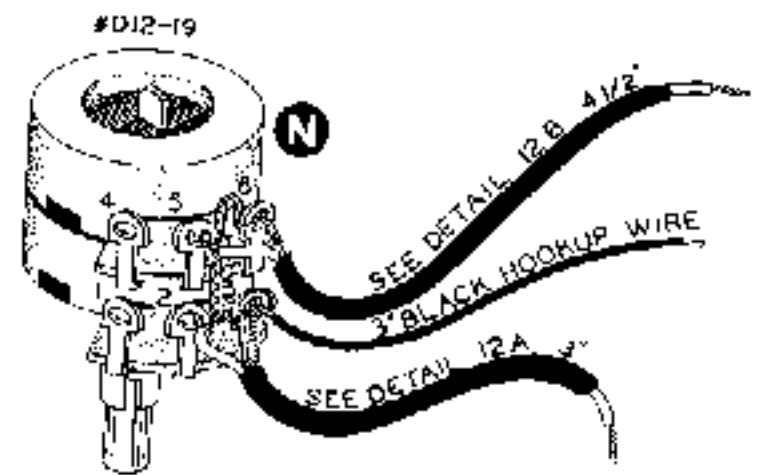

Detail 12C

(✓) Install the VOLUME control on the front panel and connect the BLACK hookup wire from N3 to P9 (NS). Refer to Pictorial 12.

(✓) Insert the shielded lead from N2 and N3 through the hole located near V3 and connect the insulated lead to pin 1 of V3 (S-1).

(✓) Insert the shielded lead from N5 and N6 through the hole located near V4 and connect the insulated lead to pin 1 of V4 (S-1).

(✓) Connect the capacitor lead extending from the chassis directly under N1 to N1 (S-1).

(✓) Connect the capacitor lead extending from the chassis directly under N4 to N4 (S-1).

(✓) Connect the GREEN lead extending from the chassis near the INPUT SELECTOR switch through both lugs at P2 (S-1).

(✓) Connect the BLUE lead extending from the chassis near the VOLUME control through both lugs at P8 (S-1).

(✓) Trim both leads of a 33 K Ω resistor (ORANGE-ORANGE-ORANGE) to a length of 3/8" and connect between P9 (NS) and both lugs at P11 (NS). DO NOT crimp these leads in the lugs, simply insert the lead through the lugs.

(✓) Trim one lead of a 33 K Ω resistor (ORANGE-ORANGE-ORANGE) to a length of 3/8" and the other lead to 3/4"

(✓) Insert the 3/8" lead through lug P9 (NS) and the 3/4" lead through P12 (NS). DO NOT crimp these leads.

(✓) Prepare a 5 1/4" length of GREEN hookup wire by stripping 1/4" of insulation from each end and connect one lead to both lugs at P11 (S-2). Dress this lead close to the chassis as shown in Pictorial 12 and connect the other end to RR2 (NS).

(✓) Prepare a 5 1/4" length of GREEN hookup wire by stripping 1/4" of insulation from each end and connect one end to both lugs at P12 (S-2). Dress this lead close to the chassis as shown in Pictorial 12 and connect the other end to SS1 (NS).

(✓) Trim both leads of a 220 K Ω resistor (RED-RED-YELLOW) to a length of 3/4" and insert one end through P9 (S-4) and the other lead through P1 (NS).

(✓) Prepare a 5 1/2" length of GREEN hookup wire and connect one end through both lugs at P1 (S-2) and connect the other end to SS3 (NS).

(✓) Prepare a 5 1/2" length of BLACK hookup wire and connect one end to P3 (NS). Dress the other end close to the chassis and through the blank lug hole in terminal strip SS. Refer to Pictorial 12. Leave the end free.

(✓) Trim both leads of a 33 K Ω resistor (ORANGE-ORANGE-ORANGE) to a length of 3/8" and connect between P3 (NS) and both lugs at P5 (NS). DO NOT crimp these leads.

- (✓) Prepare a 5 1/2" length of BLUE hookup wire and connect between both lugs of P5 (S-2) and RR1 (NS). Dress this lead close to the chassis as shown in Pictorial 12.
- (✓) Trim one lead of a 33 KΩ resistor (ORANGE-ORANGE-ORANGE) to a length of 3/8" and the other lead to 3/4".
- (✓) Insert the 3/8" lead through lug P3 (NS) and the 3/4" lead through both lugs at P6 (NS).
- (✓) Prepare a 3 3/4" length of BLUE hookup wire and connect between both lugs at P6 (S-2) and RR3 (NS). Dress this lead close to the chassis as shown in Pictorial 12.
- (✓) Trim both leads of a 220 KΩ resistor (RED-RED-YELLOW) to a length of 3/4" and insert one end through P3 (S-4). Connect the other lead through both lugs at P7 (NS).
- (✓) Prepare a 3" length of BLUE hookup wire and connect one end to both lugs at P7 (S-2). Connect the other end to SS2 (NS). Dress this lead close to the chassis as shown in Pictorial 12.
- (✓) Trim the band lead of a .01 μfd 400 V capacitor to a length of 1 3/4" and place 1 1/2" of sleeving over this lead. Slip 2 1/4" of sleeving over the opposite lead.
- (✓) Position the capacitor close to the chassis and front apron and connect the band lead to P10 (S-1). Insert the other lead through the hole located near V1 and connect to pin 7 of V1 (S-2).
- (✓) Trim both leads of a .01 μfd 400 V capacitor to a length of 2" and place 1 3/4" of sleeving over each lead.
- (✓) Position this capacitor as in Pictorial 12 and connect the band lead to P4 (S-1). Dress the other lead through the hole located near V2 and connect it to pin 7 of V2 (S-2).
- (✓) Connect the heavy bare wire from BB1 to the heavy bare wire installed on the input terminal bracket (S-1). This wire should have a very good mechanical connection before soldering.
- (✓) Connect the GREEN wire from pin 2 of V1 to pin 1 of YY (S-2).
- (✓) Connect the BLUE wire from pin 2 of V2 to pin 2 of YY (S-2).
- (✓) Connect the BLACK wire from P3 to the heavy bare wire located on the input bracket (S-1).
- (✓) Locate two 2.2 megohm resistors (RED-RED-GREEN) and two 10 μμf disc capacitors; prepare two networks as shown in Detail 12D.
- (✓) Trim both leads of one resistor-capacitor combination to a length of 5/8" and connect between XX1 (S-1) and SS3 (S-2). Refer to Pictorial 12.
- (✓) Trim one lead of the other resistor-capacitor combination to a length of 1/2" and the other lead to 1". Connect the 1/2" lead to XX2 (S-1) and the other lead to SS2 (S-2). Keep the 10 μμf disc capacitors as far apart as possible.
- (✓) Trim both leads of a 470 KΩ resistor (YELLOW-VIOLET-YELLOW) to a length of 1/2" and connect between UU1 (S-1) and SS1 (S-2).
- (✓) Trim one lead of a 470 KΩ resistor (YELLOW-VIOLET-YELLOW) to a length of 1/2" and the other lead to 1".



Detail 12D

- (✓) Connect the 1/2" lead to UU2 (S-1) and the 1" lead to RR3 (S-2).
- (✓) Trim one lead of a 470 K Ω resistor (YELLOW-VIOLET-YELLOW) to a length of 1/2" and the other lead to 3/4".
- (✓) Connect the 1/2" lead to TT1 (S-1) and the 3/4" lead to RR2 (S-2).
- (✓) Trim one lead of a 470 K Ω resistor (YELLOW-VIOLET-YELLOW) to a length of 3/8" and the other lead to 1".
- (✓) Connect the 3/8" lead to TT2 (S-1) and the 1" lead to RR1 (S-2).

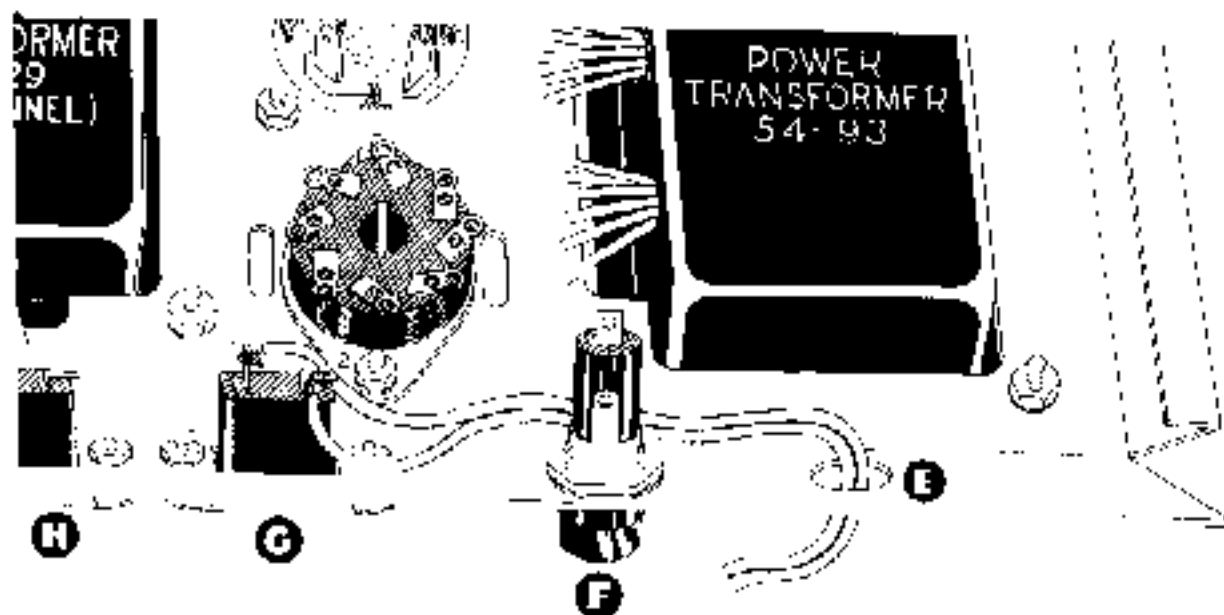

Detail 13A

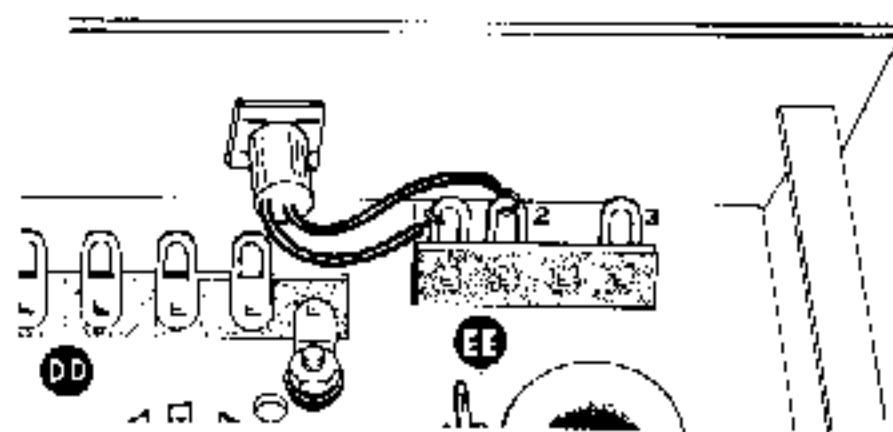

Detail 13C



Detail 13B

- (✓) Turn the amplifier upside down and place the line cord through hole E. Tin both exposed leads and connect one lead to G1 (S-2) and the other lead to G2 (S-4). Refer to Detail 13A.
- (✓) Install the line cord strain relief as shown in Detail 13B.
- (✓) Slip a 1 1/2" length of sleeving over one lead of the pilot lamp mounted on the front panel and connect it to EE2 (S-2). Refer to Detail 13C.
- (✓) Slip a 1 1/4" length of sleeving over the other lead from the pilot lamp and connect to EE1 (S-2).

- (/) Carefully inspect each lug on the bottom of the chassis; all lugs should have leads soldered securely to them with the exception of pins 1, 6, and 8 of V7, V8, V9, and V10, two ground lugs, 2 and 4 at D, pins 1, 3, 5, and 7 of V11. Where there is a doubt whether or not all leads are soldered to a lug, heat the lug with a soldering iron. Check that section of the manual for lugs other than those mentioned above that have no solder, you may have missed a step.
- (/) Check all connections on top of the chassis in the same manner, all lugs should be soldered with the exception of the BLACK insulated lead placed through the mounting lug at SS. Inspect both switches for dripped or overflowed solder on the rotor.
- (/) This completes the wiring and parts assembly of your SA-2 Amplifier. Shake and remove all solder drippings and loose pieces of wire from the chassis.

FINAL TEST, OPERATION, AND SPEAKER CONNECTION

- (/) The tubes employed in the design of the SA-2 Stereo Amplifier are of the miniature type. The base pins are small in diameter and very brittle, therefore caution should be exercised in the installation of each tube in its proper socket. The blank pin should be oriented properly with respect to the socket before pressure is applied to seat the pins into the socket. The Heath Company cannot be held responsible for mishandled tubes.

Refer to Pictorial 14 and perform the following five steps:

- (/) Cut the label sheet on the dotted lines and mount the output label as shown in Pictorial 14.
- (/) Install the 12AX7 tubes at V1 and V2.
- (/) Install the 6AU6 tubes at V3 and V4.
- (/) Install the 6AN8 tubes at V5 and V6.
- (/) Install the EL84/6BQ5 tubes at V7, V8, V9, and V10.
- (/) DO NOT install the fuse or the GZ34/5AR4 tube at this time.
- (/) Install the smallest of the six knobs supplied on the VOLUME control shaft by tightening the knob setscrew. Pull the knob to disengage the clutch within the control. Remove the knob and rotate the inner and outer control shafts to the full counterclockwise position. Engage the control clutch by pressing the inner shaft toward the front panel.
- (/) The largest knob supplied may have a gold insert pressed into its face; if so, remove this insert by pressing a nail or a small screwdriver through the rear of the knob to force the insert out. DO NOT remove the gold insert from the other knobs.
- (/) Note the two splines in the center hole of the knob and insert the knob with the splines matching the two slots on the outer shaft of the VOLUME control. The knob pointer should be on the lower left.
- (/) Install the smallest knob supplied on the inner shaft of the VOLUME control. The knob pointer should be oriented the same as the large one just installed.
- (/) Note the flat area on the remaining four control shafts, and the flat within the remaining knobs. Align the flats and install the knobs on the INPUT SELECTOR, BASS, TREBLE, and FUNCTION SELECTOR control shafts.

() Place the controls in the following positions:

INPUT SELECTOR - AUX

VOLUME - full counterclockwise

BASS - one-half counterclockwise

TREBLE - AC OFF

FUNCTION SELECTOR - STEREO

SPEAKER PHASE (located on the rear of the chassis) - NORMAL

- (✓) Plug the line cord into a 117 V 50/60 cycle AC receptacle. Turn the amplifier ON (the AC ON/OFF switch is located on the TREBLE control). The amplifier should be inoperative. If the tube filaments light or the pilot lamp glows, remove the plug and recheck the line cord, switch, power transformer, and fuse holder wiring.
- (✓) Plug a household lamp into the rear chassis NORMAL AC OUTLET; the lamp should be on. Switch the amplifier ON and OFF; the lamp should remain on.
- (✓) Remove the lamp plug and insert it into the SWITCHED AC OUTLET. Alternately turn the amplifier ON and OFF. The lamp should respond to the ON and OFF positions.
- (✓) Remove the lamp plug from the amplifier outlet and remove the amplifier plug from the wall receptacle. Install the 2 amp fuse in the fuse holder (F) and place the amplifier ON/OFF switch in the OFF position.

() Phased speakers indicate that the cones of two or more speakers travel in the same direction at the same instant with the same voltage polarity applied. Proper phasing can be accomplished by use of a common 1 1/2 V flashlight cell. Twist the bared ends of the speaker leads together to form a pair as shown in Detail 14A.

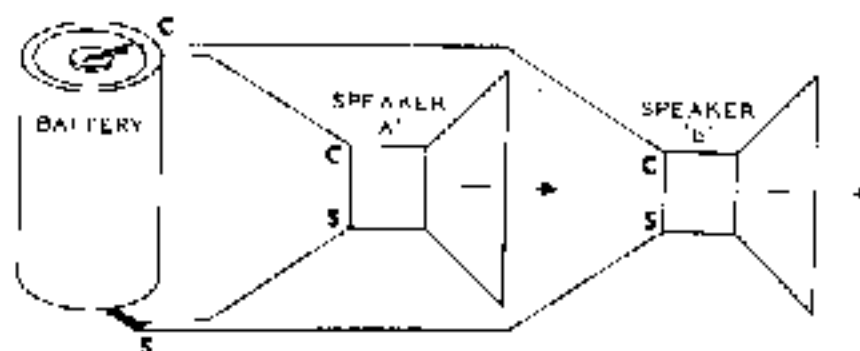

Detail 14A

() As the cell is applied to the speaker leads, note the direction of travel of the speaker cones. If they travel in the same direction at the same instant, the speakers are in phase. If not, reverse one speaker lead and the cones will be in-phase. As a reference, mark or tag one set of leads "C" and the other leads "S".

() Refer to Pictorial 14 for identification of the speaker terminals and proper connections.

(✓) Connect the lead of the A Channel speaker (left speaker for stereo applications) to the CHANNEL A, C terminal. Connect the "S" lead of the A Channel speaker to the tap that matches the speaker voice coil impedance, 4 Ω , 8 Ω , or 16 Ω .

- () Connect the "C" lead of the B Channel speaker (right speaker for stereo applications) to the CHANNEL B SPKR "C" terminal, and the "S" lead to SPKR "S". Connect the impedance matching wire to the tap matching the right speaker voice coil impedance, 4 Ω , 8 Ω , or 16 Ω .

CAUTION: Do not operate the SA-2 without a load across the speaker terminals. A 4 Ω , 8 Ω , or 16 Ω 20 watt resistor may be substituted for either speaker.

- () Plug the amplifier cord into a 117 V 50/60 cycle AC wall receptacle and turn the amplifier ON. Rotate the TREBLE control one-half turn from counterclockwise position.
- () The pilot lamp should glow and the filaments of the tubes installed should light. Observe the tubes that are lit and plug the GZ34/5AR4 tube in the octal socket V11. If the plates (the largest dark metal portion of the tubes) start to glow red, remove the amplifier plug from the wall outlet immediately and refer to IN CASE OF DIFFICULTY section of this manual.
- (✓) Place the tube shields over V1 and V2. Press them down and turn them clockwise until they are seated in position. Make certain no wires are between the shield and chassis.
- (✓) Refer to the following block instructions and place the controls in the indicated positions. Wrap the head end of a nail with tape, and holding the nail by the insulated end, insert it into the indicated input jacks. Slowly advance the VOLUME control until hum is heard from the indicated speakers. Do not advance the VOLUME control further than necessary.

PLACE NAIL IN INPUT JACK	INPUT SELECTOR POSITION	FUNCTION SELECTOR POSITION	HUM SHOULD BE HEARD FROM SPEAKER ONLY
✓ MAG PHONO "A"	MAG PHONO	AMP "A"	A CHANNEL
MAG PHONO "B"	MAG PHONO	AMP "B"	B CHANNEL
✓ MAG PHONO "A"	MAG PHONO	MONO "A"	A and B CHANNEL
✓ MAG PHONO "B"	MAG PHONO	MONO "B"	A and B CHANNEL
✓ MAG PHONO "A"	MAG PHONO	STEREO	A CHANNEL
MAG PHONO "B"	MAG PHONO	STEREO	B CHANNEL
MAG PHONO "A"	MAG PHONO	STEREO REV	B CHANNEL
✓ MAG PHONO "B"	MAG PHONO	STEREO REV	A CHANNEL
✓ XTAL PHONO "A"	XTAL PHONO	STEREO	A CHANNEL
XTAL PHONO "B"	XTAL PHONO	STEREO	B CHANNEL
✓ TUNER "A"	TUNER	STEREO	A CHANNEL
TUNER "B"	TUNER	STEREO	B CHANNEL
✓ AUX "A"	AUX	STEREO	A CHANNEL
AUX "B"	AUX	STEREO	B CHANNEL

- () If difficulty has arisen during the preceding steps, refer to the IN CASE OF DIFFICULTY section of this manual.
- (/) Loosen the two input bracket mounting screws and place the input shield plate beneath the screw heads from the top of the chassis. Then firmly tighten the two mounting screws. This plate will shield the INPUT SELECTOR switch and VOLUME controls from the output transformers and tubes.

INSTALLATION OF BOTTOM COVER AND CABINET

- () Refer to Pictorial 15 and follow the steps for final assembly of the feet, bottom cover and cabinet.

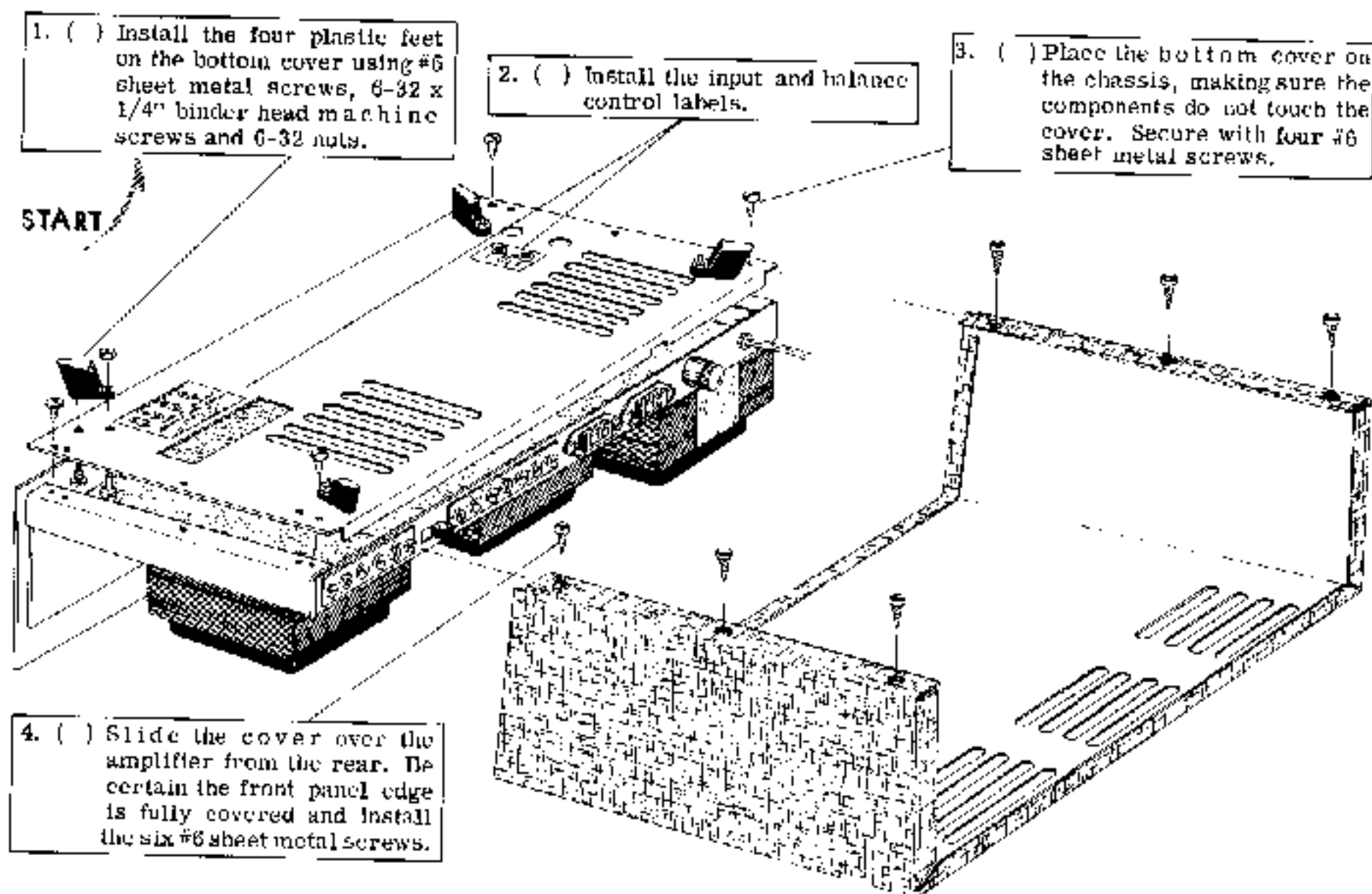

Pictorial 15

FILAMENT BALANCE CONTROL ADJUSTMENT

- (/) Plug the amplifier line cord in a 117 V AC receptacle; place the INPUT SELECTOR switch in the MAG PHONO position and the FUNCTION SELECTOR in AMP A position. With no connection to the input jacks, turn the VOLUME control clockwise until hum is clearly heard from the left speaker. Turn the amplifier on its side and adjust the A filament balance control for minimum hum from the left speaker.
- (/) Place the FUNCTION SELECTOR switch in the AMP B position. Rotate the VOLUME control until hum is clearly heard from the right speaker. Adjust the B filament balance control for minimum hum from the right speaker.

NOTE: Some benefit might be obtained if readjustment is made after the entire system is connected together.

- (/) Refer to Pictorial 16 as an example of a typical installation of combined units.

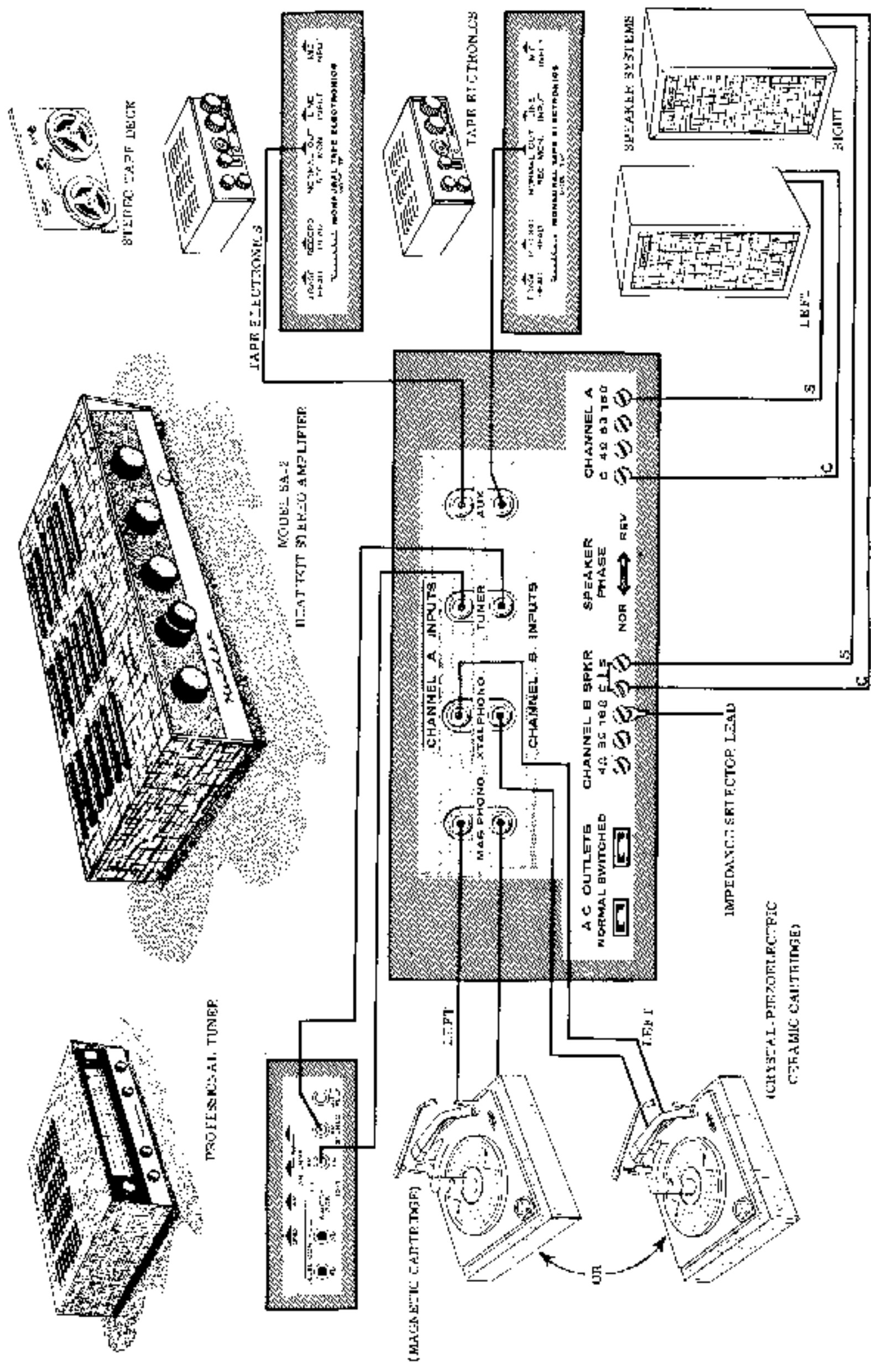

Pictorial 16

IN CASE OF DIFFICULTY

1. Recheck the wiring. Trace each lead in colored pencil on the pictorial as it is checked. It is frequently helpful to have a friend check your work. Someone who is not familiar with the unit may notice something consistently overlooked by the constructor.
2. It is interesting to note that about 90% of the kits that are returned for repair are defective due to poor connections and soldering. Therefore, many troubles can be eliminated by re-heating all connections to make sure that they are soldered as illustrated in the Figures found in the SOLDERING TECHNIQUES section of this manual.
3. Check tube locations to be sure that all tubes are in their proper locations. Make sure that all tubes light up properly.
4. Check the values of the component parts. Be sure that the proper part has been wired into the circuit, as shown in the pictorial diagram and as called out in the wiring instructions.
5. Check for bits of solder, wire ends or other foreign matter which may be lodged in the wiring beneath the chassis.
6. If, after careful checks, the trouble is still not located and a voltmeter is available, check voltage readings against those found on the Schematic Diagram. NOTE: All voltage readings were taken with a Heathkit Vacuum Tube Voltmeter. Voltages may vary 10% due to line voltage variations.
7. A review of the circuit description and block diagrams will prove helpful in indicating where to look for trouble.
8. Remove the tubes and have a competent radio repairman check them.
9. If the difficulty has not been located, the following procedure is suggested:

CAUTION: There is high voltage present at various points throughout the SA-2. The red leads indicate high DC voltages or B+. DO NOT TOUCH THESE. The A Channel is wired with green and the B Channel is wired with blue wire. Be certain you have the proper test point located before proceeding with the check. Do not touch the chassis, other than the points indicated. With the speakers properly connected, turn the amplifier ON and allow a few minutes to warm up. Hold the insulated end of the prepared nail, "scratch" the test point indicated, and the proper speaker should respond with a "scratching" sound or hum.

INPUT SELECTOR - MAG PHONO

VOLUME CONTROL - one-quarter turn from counterclockwise position.

Do not adjust higher than necessary to obtain an audible sound from the speaker. Serious damage may occur to the output tubes or speakers due to the high gain of the SA-2.

BASS and TREBLE CONTROLS - one-half rotation from counterclockwise.

FUNCTION SELECTOR - STEREO

A Channel Test: "Scratch" the control grid (pin 2) of V7 and V8; a faint "scratching" should be heard from the A Channel speaker. Scratch the control grid (pin 2) of V6-B; the sound should increase slightly. Proceed then to pin 8 of V6-A, pin 1 of V3, pin 7 of V1-B, then to pin 2 of V1-A.

B Channel Test: "Scratch" the control grid (pin 2) of V9 and V10; a faint "scratching" should be heard from the B Channel speaker. "Scratch" the control grid (pin 2) of V5-B; the sound should increase slightly. Proceed then to pin 8 of V5-A, pin 1 of V4, pin 7 of V2-B, then to pin 2 of V2-A.

The point at which no sound is heard is the stage where the difficulty lies. Recheck the voltages, wiring and components in this particular stage.

INSTALLATION AND OPERATION

Heat is naturally generated within all power amplifiers such as the SA-2 Stereo Amplifier due to the high gain and power designed into the unit, therefore adequate ventilation around the cabinet is a necessity. At least 1" of open area around the bottom cover, 1" of open area behind the rear apron, and 3" above the top of the cabinet would be considered minimum adequate ventilation. Vertical mounting of the chassis with the supplied cabinet installed is not recommended. The chassis without the cabinet may be vertically mounted in a custom installation if certain precautions are exercised. The front panel should be spaced 1/8" above the mounting surface to provide circulation around the panel and sufficient ventilation should be supplied within the cabinet to allow a free flow of air around the entire chassis.

The sources and speakers illustrated in the typical installation in Pictorial 16 are merely for an example of the interconnection of sources, SA-2 Stereo Amplifier and speakers, rather than designating the only possible and correct combination.

The XTAL PHONO input was designed for crystal or piezoelectric phono cartridges, but may be used for any high level input. The TUNER and AUX inputs are identical in design and may be used for high level inputs from practically any type of sound source equipment.

The INPUT SELECTOR switch selects the desired signal source indicated on the front panel without interference from the three remaining dual inputs.

The FUNCTION SELECTOR switch is quite similar to the INPUT SELECTOR switch inasmuch as it routes either or both of the selected input signals to the input of the power amplifiers. AMP A and AMP B positions route the respective input signal only through its respective power amplifier and speaker. No audio will be produced from the opposite speaker. MONO A and MONO B positions route the respective input signal to both power amplifiers and will be produced from both the A and B speakers. STEREO and STEREO REV route the A and B input signals to the respective amplifiers and speakers or opposite amplifiers and speakers. As an example, the listener can change the direction of travel of a recorded train to go from left to right, or right to left. You may place the string section of an orchestra to the left or right of the brass section.

The VOLUME CONTROL is designed as a clutch operated control, making it possible to operate as a dual tandem or dual concentric control. With the inner small knob pressed tight against the large outer knob the control is a dual tandem, that is, both controls rotate in unison by turning either knob. With the inner small knob pulled out approximately 3/16" from the larger or outer knob the control is dual concentric, that is, either control may be rotated individually by turning its respective knob. This feature allows the control to be used as a balance control.

The BASS and TREBLE controls are dual tandem, thereby adjusting the emphasis or attenuation of desired or undesired tones of both the A and the B amplifiers simultaneously. These tone controls make it possible to produce tones exactly as they were recorded or to adjust the tones for the listening pleasure of the individual.

The SPEAKER PHASE switch is located on the rear apron of the SA-2. The function of this switch is to reverse the B Channel speaker connections. The NORMAL position is correct if the signal sources selected are in-phase with one another and the speakers are in-phase. When either the input signals or the speakers are out-of-phase, the phase reversal switch will compensate for this error. If the material produced is out-of-phase there will be a slight cancellation of program material, especially the low frequency tones. To determine whether or not the reproduced audio is in or out of phase, adjust the output of each speaker individually to produce the same level of audio. This can be done by setting the FUNCTION SELECTOR switch in the AMP A position and adjusting the A Channel volume control for normal listening level from the left speaker. Switch the FUNCTION SELECTOR switch to AMP B. Holding the A Channel volume control knob in a stationary position, set the B Channel volume control knob to equal the same level from the right speaker as was produced from the left speaker when the FUNCTION SELECTOR switch was in the AMP A position.

Once the two speaker output levels are balanced, place the FUNCTION SELECTOR switch in the STEREO position and switch the SPEAKER PHASE switch from the NORMAL to the REVERSE positions approximately 5 seconds apart. You will note a slight difference in output level and a difference in direction from which the program material seems to be originating. The highest output level and full sound will be the proper position for the SPEAKER PHASE switch. With some stereo material, this test may be difficult to make because of extreme separation between channels. It is suggested that a standard monophonic record be used under the conditions described above. The sound will be full and centered when proper phase relationships are achieved. The A and B speakers should be placed approximately 8 feet apart and slightly toed in. Room size and furnishings prevent this from being a fixed rule. A little time experimenting with the position of the speakers will be worthwhile in determining the best listening arrangement for a particular room.

It is good operating practice to leave the VOLUME control for the unused preamplifier in the full counterclockwise (minimum) position when operating the SA-2 for monophonic reproduction. This will avoid any possibility of interference from the unused channel.

SERVICE

If, after applying the information contained in this manual and your best efforts, you are still unable to obtain proper performance, it is suggested that you take advantage of the technical facilities which the Heath Company makes available to its customers.

The Technical Consultation Department is maintained for your benefit. This service is available to you at no charge. Its primary purpose is to provide assistance for those who encounter difficulty in the construction, operation or maintenance of HEATHKIT equipment. It is not intended, and is not equipped to function as a general source of technical information involving kit modifications nor anything other than the normal and specified performance of HEATHKIT equipment.

Although the Technical Consultants are familiar with all details of this kit, the effectiveness of their advice will depend entirely upon the amount and the accuracy of the information furnished by you. In a sense, YOU MUST QUALIFY for GOOD technical advice by helping the consultants to help you. Please use this outline:

1. Before writing, fully investigate each of the hints and suggestions listed in this manual under In Case Of Difficulty. Possibly it will not be necessary to write.
2. When writing, clearly describe the nature of the trouble and mention all associated equipment. Specifically report operating procedures, switch positions, connections to other units and anything else that might help to isolate the cause of trouble.
3. Report fully on the results obtained when testing the unit initially and when following the suggestions under In Case Of Difficulty. Be as specific as possible and include voltage readings if test equipment is available.
4. Identify the kit model number and date of purchase, if available.
5. Print or type your name and address, preferably in two places on the letter.

With the above information, the consultant will know exactly what kit you have, what you would

like it to do for you and the difficulty you wish to correct. The date of purchase tells him whether or not engineering changes have been made since it was shipped to you. He will know what you have done in an effort to locate the cause of trouble and, thereby, avoid repetitious suggestions. He will make no incorrect assumptions nor waste time checking files for the correct spelling of name and address. (The automatic letter opener sometimes cuts through the letter, hence the suggestion to print the name and address twice.) In short, he will devote full time to the problem at hand, and through his familiarity with the kit, plus your accurate report, he will be able to give you a complete and helpful answer. If replacement parts are required, they will be shipped to you, subject to the terms of the Warranty.

The Factory Service facilities are also available to you, in case you are not familiar enough with electronics to provide our consultants with sufficient information on which to base a diagnosis of your difficulty, or in the event that you prefer to have the difficulty corrected in this manner. You may return the completed instrument (including all connecting cables) to the Heath Company for inspection and necessary repairs and adjustments. You will be charged a fixed fee of \$12.00, plus the price of any additional parts or material required. However, if the completed kit is returned within the Warranty period, parts charges will be governed by the terms of the Warranty. State the date of purchase, if possible.

Local Service by Authorized HEATHKIT Service Centers is also available in some areas and often will be your fastest, most efficient method of obtaining service for your HEATHKIT equipment. Although you may find charges for local service somewhat higher than those listed in HEATHKIT manuals (for factory service), the amount of increase is usually offset by the transportation charge you would pay if you elected to return your kit to the Heath Company.

HEATHKIT Service Centers will honor the regular 90 day HEATHKIT Parts Warranty on all kits, whether purchased through a dealer or directly from Heath Company; however, it will be necessary that you verify the purchase date of your kit.

Under the conditions specified in the Warranty, replacement parts are supplied without charge; however, if the Service Center assists you in locating a defective part (or parts) in your kit, or installs a replacement part for you, you may be charged for this service.

HEATHKIT equipment purchased locally and returned to Heath Company for service must be accompanied by your copy of the dated sales receipt from your authorized HEATHKIT dealer in order to be eligible for parts replacement under the terms of the Warranty.

THIS SERVICE POLICY APPLIES ONLY TO COMPLETED EQUIPMENT CONSTRUCTED IN ACCORDANCE WITH THE INSTRUCTIONS AS STATED IN THE MANUAL. Equipment that has been modified in design will not be accepted for repair. If there is evidence of acid core solder or paste fluxes, the equipment will be returned NOT repaired.

For information regarding modification of HEATHKIT equipment for special applications, it is suggested that you refer to any one or more of the many publications that are available on all phases of electronics. They can be obtained at or through your local library, as well as at most electronic equipment stores. Although the Heath Company sincerely welcomes all comments and suggestions, it would be impossible to design, test, evaluate and assume responsibility for proposed circuit changes for special purposes. Therefore, such modifications must be made at the discretion of the kit builder, using information available from sources other than the Heath Company.

REPLACEMENTS

Material supplied with HEATHKIT products has been carefully selected to meet design requirements and ordinarily will fulfill its function without difficulty. Occasionally improper instrument operation can be traced to a faulty component. Should inspection reveal the necessity for replacement, write to the Heath Company and supply all of the following information.

A. Thoroughly identify the part in question by using the part number and description found in the manual Parts List.

- B. Identify the type and model number of kit in which it is used.
- C. Mention date of purchase.
- D. Describe the nature of defect or reason for requesting replacement.

The Heath Company will promptly supply the necessary replacement. **PLEASE DO NOT RETURN THE ORIGINAL COMPONENT UNTIL SPECIFICALLY REQUESTED TO DO SO.** Do not dismantle the component in question as this will void the guarantee. This replacement policy does not cover the free replacement of parts that may have been broken or damaged through carelessness on the part of the kit builder.

SHIPPING INSTRUCTIONS

In the event that your instrument must be returned for service, these instructions should be carefully followed.

ATTACH A TAG TO THE EQUIPMENT BEARING YOUR NAME, COMPLETE ADDRESS, DATE OF PURCHASE, AND A BRIEF DESCRIPTION OF THE DIFFICULTY ENCOUNTERED. Wrap the equipment in heavy paper, exercising care to prevent damage. Place the wrapped equipment in a stout carton of such size that at least three inches of shredded paper, excelsior, or other resilient packing material can be placed between all sides of the wrapped equipment and the carton. Close and seal the carton with gummed paper tape, or alternately, tie securely with stout cord. Clearly print the address on the carton as follows:

To: HEATH COMPANY
Benton Harbor, Michigan

Include your name and return address on the outside of the carton. Preferably affix one or more "Fragile" or "Handle With Care" labels to the carton, or otherwise so mark with a crayon of bright color. Ship by parcel post or prepaid express; note that a carrier cannot be held responsible for damage in transit if, in HIS OPINION, the article is inadequately packed for shipment.

SPECIFICATION CHANGES

All prices are subject to change without notice. The Heath Company reserves the right to discontinue instruments and to change specifications at any time without incurring any obligation to incorporate new features in instruments previously sold.

WARRANTY

Heath Company warrants that for a period of three months from the date of shipment, all Heathkit parts shall be free of defects in materials and workmanship under normal use and service and that in fulfillment of any breach of such warranty, Heath Company shall replace such defective parts upon the return of the same to its factory. The foregoing warranty shall apply only to the original buyer, and is and shall be in lieu of all other warranties, whether express or implied and of all other obligations or liabilities on the part of Heath Company and in no event shall Heath Company be liable for any anticipated profits, consequential damages, loss of time or other losses incurred by the buyer in connection with the purchase, assembly or operation of Heathkits or components thereof. No replacement shall be made of parts damaged by the buyer in the course of handling or assembling Heathkit equipment.

NOTE: The foregoing warranty is completely void and we will not replace, repair or service instruments or parts thereof in which acid core solder or paste fluxes have been used.

HEATH COMPANY

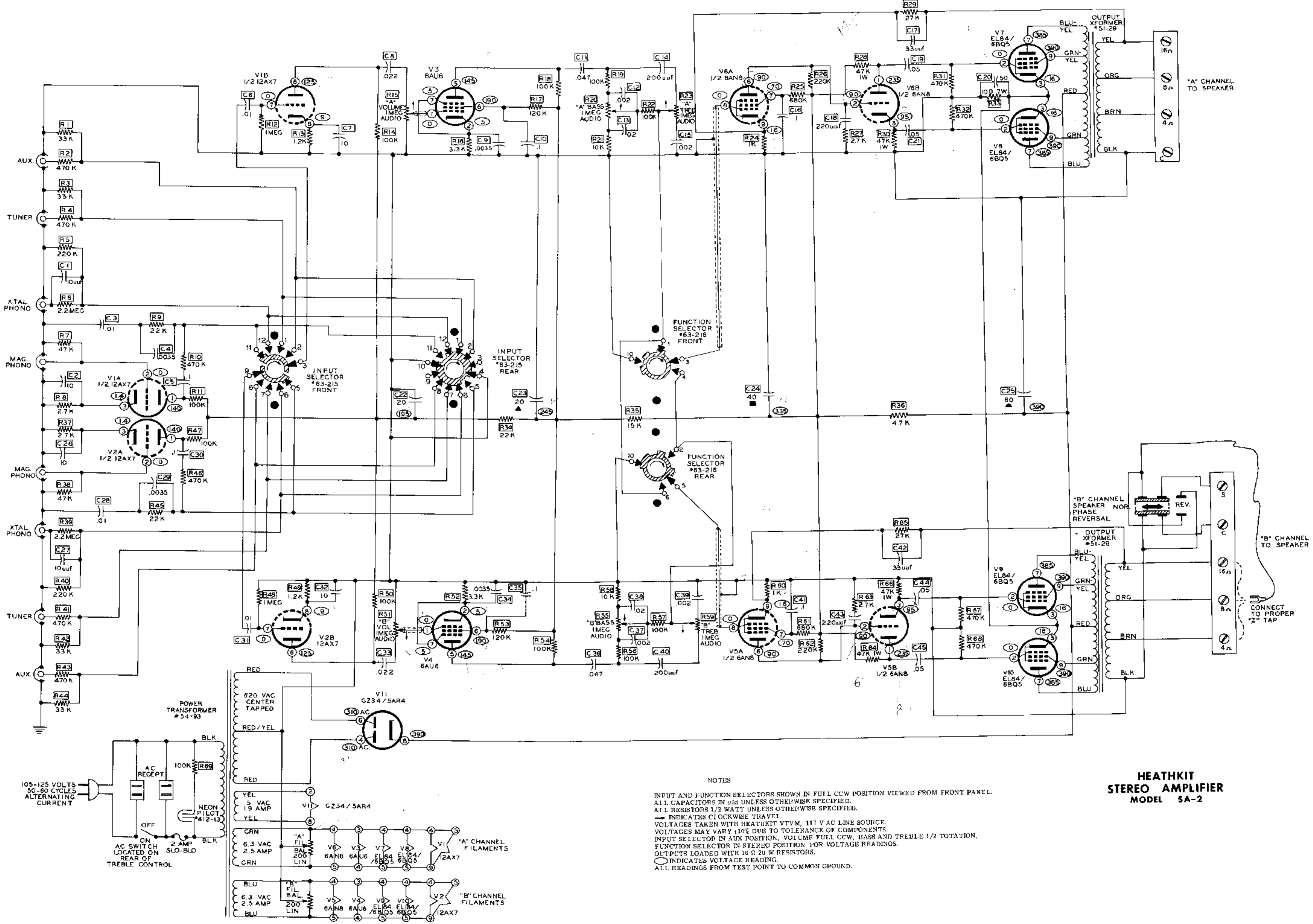

NOTES

INPUT AND FUNCTION SELECTORS SHOWN IN FULL CCW POSITION VIEWED FROM FRONT PANEL.

ALL CAPACITORS IN μ UNLESS OTHERWISE SPECIFIED.

ALL RESISTORS 1/2 WATT UNLESS OTHERWISE SPECIFIED.

→ INDICATES CLOCKWISE TRAVEL.

VOLTAGES TAKEN WITH HEATHKIT VTVM, 117 V AC LINE SOURCE.

VOLTAGES MAY VARY $\pm 10\%$ DUE TO TOLERANCE OF COMPONENTS.

INPUT SELECTOR IN AUX POSITION, VOLUME FULL CCW, BASS AND TREBLE 1/2 TOTATION, FUNCTION SELECTOR IN STEREO POSITION FOR VOLTAGE READINGS.

OUTPUTS LOADED WITH 16 Ω 20 W RESISTORS.

○ INDICATES VOLTAGE READING.

ALL READINGS FROM TEST POINT TO COMMON GROUND.

**HEATHKIT
STEREO AMPLIFIER
MODEL SA-2**

