

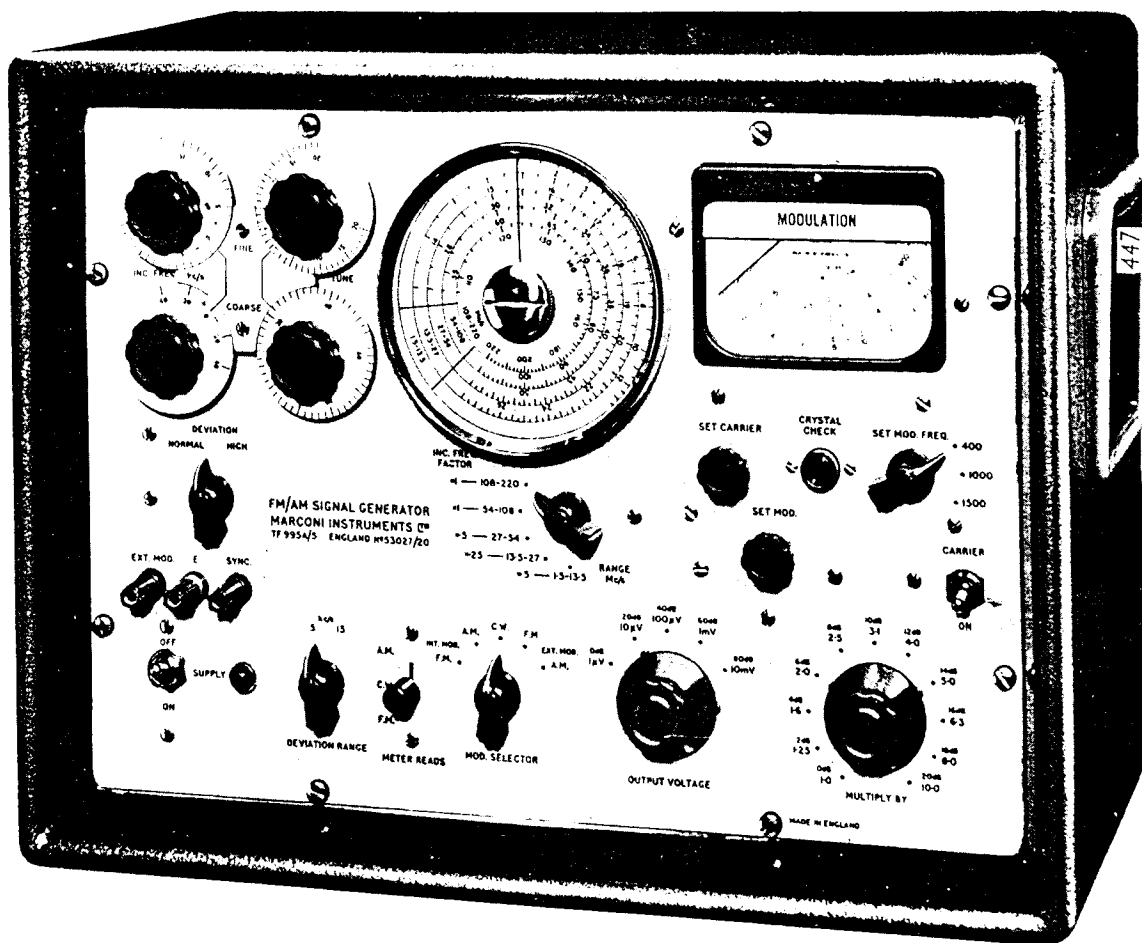

For Service Manuals Contact  
MAURITRON TECHNICAL SERVICES  
8 Cherry Tree Rd, Chinnor  
Oxon OX9 4QY  
Tel:- 01844-351694 Fax:- 01844-352554  
Email:- enquiries@mauritron.co.uk

FM/AM SIGNAL GENERATOR  
TF 995A/5

For Service Manuals Contact  
MAURITRON TECHNICAL SERVICES  
8 Cherry Tree Rd, Chinnor  
Oxon OX9 4QY  
Tel:- 01844-351694 Fax:- 01844-352554  
Email:- enquiries@mauritron.co.uk



OPERATING/AND/MAINTENANCE HANDBOOK  
No. OM 995A/5

# F.M./A.M. Signal Generator

## TF 995A/5

# CONTENTS

Section	Page
DATA SUMMARY ... ..	4
SCHEDULE OF PARTS SUPPLIED ... ..	6
<b>1</b> INTRODUCTION ... ..	<b>7</b>
<b>2</b> OPERATION ... ..	<b>9</b>
2.1 INSTALLATION ... ..	9
2.2 SWITCHING ON AND WARMING UP ... ..	9
2.3 OUTPUT CONNECTIONS ... ..	9
2.4 TUNING ... ..	9
2.4.1 General Tuning ... ..	9
2.4.2 Use of the Crystal Calibrator ... ..	10
2.4.3 Incremental Frequency Controls ... ..	12
2.4.4 Interpolating Dial ... ..	12
2.5 SETTING UP FOR C.W. OR MODULATED OUTPUT ... ..	13
2.5.1 Continuous Wave ... ..	14
2.5.2 Amplitude Modulation ... ..	14
2.5.3 Frequency Modulation ... ..	15
2.5.4 Simultaneous F.M. and A.M. ... ..	17
2.6 R.F. OUTPUT ARRANGEMENTS ... ..	17
2.6.1 Outputs from 1 $\mu$ V to 100 mV at 52 and 75 ohms ... ..	17
2.6.2 Outputs from 2 $\mu$ V to 200 mV at 75 ohms only ... ..	18
2.6.3 Outputs from 0.1 $\mu$ V to 10 mV at 52 and 75 ohms ... ..	18
2.6.4 Output in terms of voltage developed across external load ... ..	19
2.6.5 Matching to external loads other than 52 or 75 ohms ... ..	19
2.6.6 Matching to balanced loads ... ..	21
2.7 SYNCHRONIZING SIGNAL ... ..	21
<b>3</b> OPERATIONAL SUMMARY ... ..	<b>22</b>
<b>4</b> TECHNICAL DESCRIPTION ... ..	<b>23</b>
4.1 R.F. CIRCUITS ... ..	23
4.2 MODULATION SYSTEMS ... ..	24
4.3 MONITORING ARRANGEMENTS ... ..	24
4.4 POWER UNIT ... ..	24
<b>5</b> MAINTENANCE ... ..	<b>25</b>
5.1 GENERAL ... ..	25
5.2 REMOVAL OF CASE ... ..	25
5.3 MAINS INPUT ARRANGEMENTS ... ..	25
5.4 ACCESS TO ENCLOSED SUB-ASSEMBLIES ... ..	26
5.4.1 R.F. Unit ... ..	26
5.4.2 MULTIPLY BY Attenuator ... ..	26
5.4.3 OUTPUT VOLTAGE Attenuator and Monitor Diode ... ..	26
5.4.4 Mains Input Filter Unit ... ..	27
5.4.5 Power Unit ... ..	27
5.5 WORKING VOLTAGES ... ..	27
5.6 REPLACEMENT OF VALVES AND SEMICONDUCTORS ... ..	27
5.7 PRESET AND SPECIALLY SELECTED COMPONENTS ... ..	27

<i>Section</i>		<i>Page</i>
5.8	SCHEDULE OF TESTS	30
5.8.1	Apparatus Required	30
5.8.2	Insulation	30
5.8.3	Hum Level	30
5.8.4	Crystal Oscillator	30
5.8.5	Basic Oscillator	30
5.8.6	Frequency Multipliers	30
5.8.7	1.5- to 13.5-Mc/s Band	31
5.8.8	R.F. Output Voltage Accuracy	31
5.8.9	Modulation Oscillator	31
5.8.10	F.M. Distortion	32
5.8.11	F.M. Tracking and Range 2 Sensitivity	32
5.8.12	Deviation Monitor	32
5.8.13	Incremental Frequency	32
5.8.14	High Deviation	33
5.8.15	External F.M.	33
5.8.16	Internal A.M.	33
5.8.17	External A.M.	33
5.8.18	Spurious F.M. on C.W.	34
6	COMPONENT LAYOUT ILLUSTRATIONS	
	GENERAL UNDERSIDE VIEW FROM REAR (CASE REMOVED)	Fig. 6.1
	L.F. AND R.F. UNITS (TOP VIEW)	Fig. 6.2
	R.F. UNIT (GENERAL UNDERSIDE VIEW)	Fig. 6.3
	R.F. UNIT (CLOSE-UP OF PORTION OF UNDERSIDE)	Fig. 6.4
	L.F. UNIT (UNDERSIDE VIEW)	Fig. 6.5
	ATTENUATORS (COVERS REMOVED)	Fig. 6.6
	POWER UNIT	Fig. 6.7
7	SPARES ORDERING SCHEDULE	SOS 1
8	CIRCUIT DIAGRAMS	
	R.F. and L.F. Units	Fig. 8.1
	Power Unit	Fig. 8.2
	 DECIBEL CONVERSION TABLES	

For Service Manuals Contact  
**MAURITRON TECHNICAL SERVICES**  
 8 Cherry Tree Rd, Chinnor  
 Oxon OX9 4QY  
 Tel:- 01844-351694 Fax:- 01844-352554  
 Email:- enquiries@mauritron.co.uk

# DATA SUMMARY

## Frequency

RANGE:	1.5 to 220 Mc/s in five bands as follows:				
	Band 1	...	...	1.5 to 13.5 Mc/s	
	2	...	...	13.5 to 27.5 Mc/s	
	3	...	...	27 to 55 Mc/s	
	4	...	...	54 to 110 Mc/s	
	5	...	...	108 to 220 Mc/s	

## CALIBRATION ACCURACY:

From 1.5 to 13.5 Mc/s, the main frequency dial calibration has an average accuracy of  $\pm 3\%$ . From 13.5 to 220 Mc/s, the calibration of this dial is accurate to within  $\pm 1\%$ . In addition, the built-in crystal calibrator provides 14 check points to an accuracy of 2 parts in  $10^4$  on each of the four higher-frequency bands.

## STABILITY:

After warm-up, drift is not greater than 0.002% in a 10-minute period, except on lowest band.

## FINE TUNING CONTROL:

The fine tuning control provided is arbitrarily calibrated  $-20$  to  $+20$ . It has a total cover of approximately 6 kc/s on bands 1 and 3, 3 kc/s on band 2, 12 kc/s on band 4, and 24 kc/s on band 5.

## INCREMENTAL CONTROL:

Two controls are provided, one stepped, the other continuously variable. The stepped control enables the carrier frequency to be shifted by  $\pm 20$  and  $\pm 10$  kc/s on bands 1 and 3,  $\pm 10$  and  $\pm 5$  kc/s on band 2, and  $\pm 40$  and  $\pm 20$  kc/s on bands 4 and 5. The continuous control has a cover of  $\pm 0.75$  of one increment of the stepped control on any band, e.g. cover is  $\pm 15$  kc/s on bands 4 and 5.

## Output

### VOLTAGE:

Built-in coarse and fine 75-ohm attenuators connected in cascade provide—in conjunction with the 6-dB Terminating Unit—a source e.m.f. variable in 2-dB steps from  $1 \mu\text{V}$  to 100 mV. Interpolation between the 2-dB steps is by means of a  $\pm 1$ -dB calibration on the r.f. level meter.

### HIGH OUTPUTS:

Source e.m.f.'s up to 200 mV at an impedance of 75 ohms are obtained direct from the Generator output cable.

### LOW OUTPUTS:

Source e.m.f.'s down to a nominal  $0.1 \mu\text{V}$  at impedances of 75 and 52 ohms are obtained by inserting the 20-dB Attenuator Pad TM 5552 between the Generator output cable and the Terminating Unit.

### ACCURACY:

The accuracy of the joint indication of the attenuators and level meter is within  $\pm 1$  dB  $\pm 0.25 \mu\text{V}$  up to 100 Mc/s, and within  $\pm 2$  dB  $\pm 0.25 \mu\text{V}$  up to 220 Mc/s.

For Service Manuals Contact  
**MAURITRON TECHNICAL SERVICES**  
 8 Cherry Tree Rd, Chinnor  
 Oxon OX9 4QY  
 Tel: 01844-351694 Fax: 01844-352554  
 Email: enquiries@mauritron.co.uk

## Modulation

### FREQUENCY MODULATION:

Normal deviation continuously variable in two ranges  $\pm 5$  kc/s and  $\pm 15$  kc/s on all carrier bands. Accuracy at maximum deviation on bands 2, 3, 4, 5\* at 1 kc/s is  $\pm 5\%$  of f.s.d. with a possible additional variation of  $\pm 10\%$  due to valve ageing or random replacement.

High deviation is also available:—

$\times 2$  normal on bands 1 and 3,  $\times 4$  normal on band 4, and  $\times 8$  normal on band 5. Internal modulation is available at frequencies of 400 c/s, 1000 c/s and 1500 c/s with modulation distortion not exceeding 2% at maximum deviation. The external modulation characteristic is flat, within 1 dB, from 50 c/s to 15 kc/s with respect to 1 kc/s.

### SPURIOUS F.M. ON C.W.:

The spurious f.m. due to hum does not exceed 25 c/s deviation on bands 2, 3, 4, 5\*. The unusually low level of spurious noise modulation allows full use of the Generator for adjacent-channel testing on receivers designed for systems employing channel separations as small as 22.5 kc/s.

\*The wide frequency coverage on band 1 (1.5 to 13.5 Mc/s) is achieved by heterodyning the normal band 2 signal with a fixed oscillator. At some frequencies on band 1, spurious F.M. in excess of the figure quoted for the other bands may occur. At these frequencies the deviation accuracy will also be affected.

### AMPLITUDE MODULATION:

Available internally at 400 c/s, 1000 c/s and 1500 c/s to a depth variable up to 50% with distortion not exceeding 6% at 30% depth. External frequency characteristic (with input adjusted for constant modulation-meter reading) is flat within 0.5 dB from 100 c/s to 10 kc/s.

### A.M. DEPTH INDICATION:

Indication accurate to within 5% modulation.

### SYNCHRONIZING SIGNAL:

Available from front-panel terminals at 400 c/s, 1 kc/s or 1.5 kc/s.

### Power Supply:

200 to 250 volts, or 100 to 150 volts after adjusting internal link, 40 to 65 c/s; 65 watts. Models supplied ready for immediate 100- to 150-volt use if specified at the time of ordering.

### Dimensions and Weight:

<i>Height</i>	<i>Width</i>	<i>Depth</i>	<i>Weight</i>
13 in (33 cm)	17½ in (44.5 cm)	8½ in (22 cm)	40 lb (18.1 kg)



# I INTRODUCTION

The Marconi F.M./A.M. Signal Generator TF 995A/5 covers the frequency range of 1.5 to 220 Mc/s in five bands. Its output can be unmodulated, frequency modulated, or amplitude modulated; if required, both frequency and amplitude modulation can be applied simultaneously. The modulation frequency is obtained from either an internal 3-frequency oscillator, or an external source.

The open-circuit output voltage is variable by means of resistive step attenuators from 1  $\mu$ V to 100 mV at 52 ohms and 1  $\mu$ V to 200 mV at 75 ohms. A plug-in 20-dB Attenuator Pad, available as an optional accessory, extends the range down to a nominal 0.1  $\mu$ V at both impedances.

The high-discrimination tuning required for testing narrow-band systems is facilitated by the inclusion of a fine tuning control. In addition, small known changes in carrier frequency can be made by means of two incremental-frequency controls; one of these controls gives a stepped adjustment while the other allows continuous inter-

polation between steps. On the two highest bands, the stepped control provides shifts of 20 and 40 kc/s in either direction and the calibration marks on the continuous control are only 1 kc/s apart; on the lower bands, the total shift is determined by a simple division of the reading on both dials.

A high degree of frequency stability has been achieved by use of temperature-compensating components; after warm-up, drift is less than 400 c/s per minute at a carrier frequency of 200 Mc/s.

The inclusion of a Carrier on/off switch makes it possible for the Generator output to be temporarily interrupted without affecting the output impedance; this facilitates a number of two-signal receiver tests such as intermodulation and blocking which involves the simultaneous use of two signal generators. Spurious f.m. due to hum is less than 25 c/s deviation, and the low level of noise modulation makes the TF 995A/5 fully suitable for applications such as adjacent-channel testing on receiver systems using a channel separation of 25 kc/s or less.

For Service Manuals Contact  
MAURITRON TECHNICAL SERVICES  
8 Cherry Tree Rd, Chinnor  
Oxon OX9 4QY  
Tel:- 01844-351694 Fax:- 01844-352554  
Email:- enquires@mauritron.co.uk

For  
more  
information



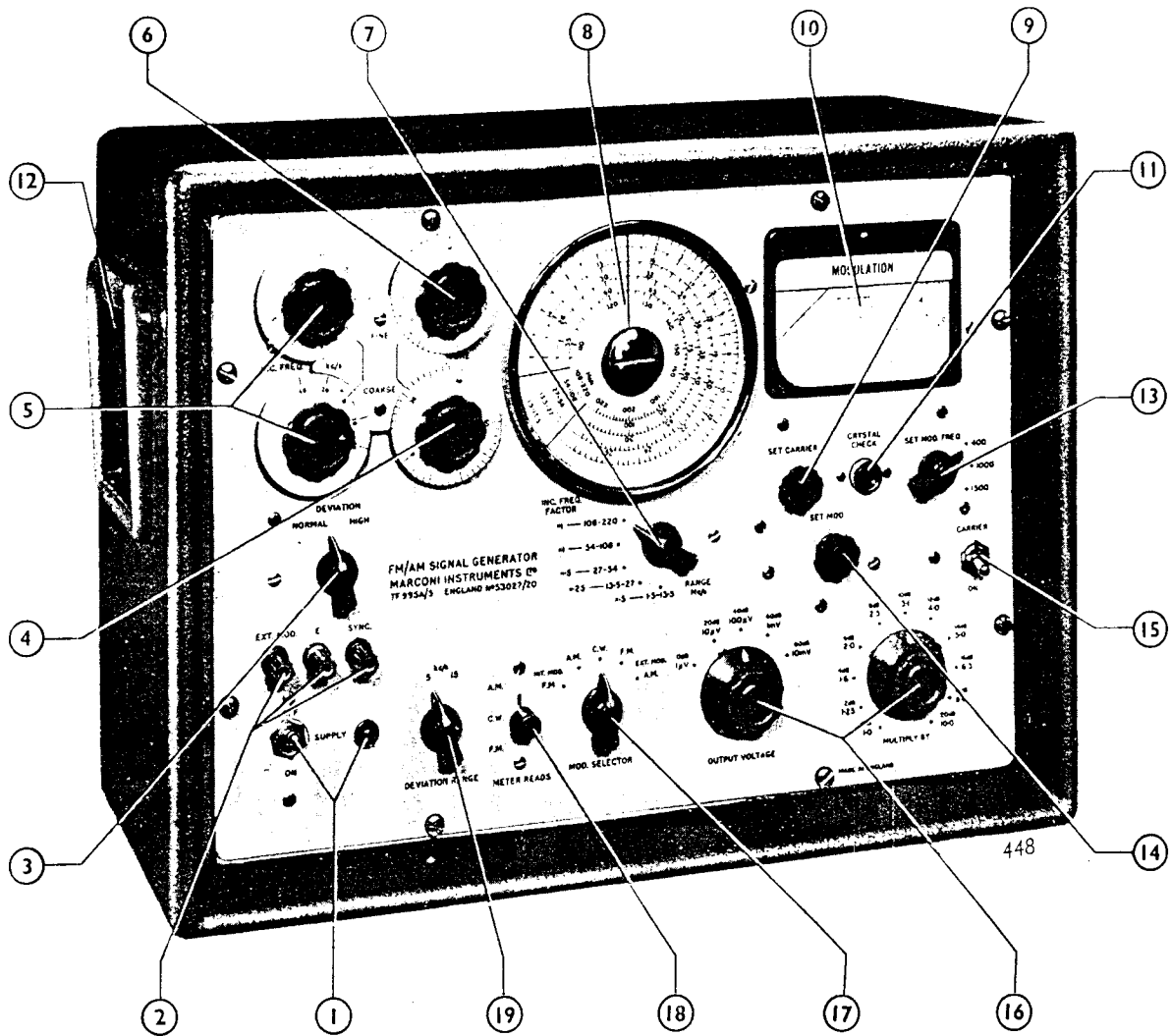

1. Pilot Lamp and Mains Supply Switch
2. External Modulation Input for f.m. or a.m. and Sync Output from internal modulation oscillator
3. Normal: deviation is as shown on meter  
High: multiply meter reading by factor on Range switch
4. Coarse Tuning Control
5. Incremental Frequency Controls  
Carrier shift is given by dial readings multiplied by factor on Range switch
6. Fine Tuning Control
7. Range Selector
8. Main Tuning Dial  
Knurled boss adjusts cursor to standardize scale against crystal check points
9. Set Carrier Control  
For adjusting unmodulated carrier to Set R.F. mark on meter
10. Meter indicates carrier level, f.m. deviation, or a.m. depth depending on setting of Meter Reads switch
11. Crystal Check Jack  
Plug in headphones here to switch on crystal check oscillator
12. Case Handle Recess stowage for mains supply plug
13. Modulation Frequency Selector  
Choice of 3 frequencies from internal oscillator
14. Set Mod Control  
Adjusts f.m. deviation or a.m. depth
15. Interrupts Output without switching off filaments
16. Output Attenuators  
Direct reading in source e.m.f. at output of Terminating Unit when carrier is adjusted to Set R.F. mark on meter
17. Modulation Selector
18. Meter Function Selector
19. Deviation Range Selector  
Read deviation from corresponding scale on meter

Fig. 2.1 Controls.

## 2 OPERATION

### 2.1 INSTALLATION

Unless otherwise specified, the Signal Generator is dispatched with its valves in position and with its mains input circuit adjusted for immediate use with a 240-volt, 40- to 65-c/s mains supply. The instrument can be adjusted for operation from any other 40- to 65-c/s supply voltage in the ranges 200 to 250 and 100 to 150 volts. To check or alter the settings of the mains transformer tapplings, refer to MAINTENANCE, Section 5.3.

### 2.2 SWITCHING ON AND WARMING UP

Before switching on, be quite sure that the instrument is correctly adjusted to suit the particular mains supply to which it is to be connected. Then proceed as follows:—

- (1) Connect the mains lead—stowed in the left-hand case-handle recess—to the mains supply socket.
- (2) Switch ON by means of the SUPPLY switch; the red pilot lamp should now glow.
- (3) Before proceeding further, allow a short time—say five minutes—to elapse for the internal circuits to warm up. If a particularly high standard of frequency stability is required, this time should be increased to about 60 minutes.

### 2.3 OUTPUT CONNECTIONS

The r.f. output from the Signal Generator is derived, at a source impedance of 75 ohms, via a permanently attached coaxial lead fitted with a BNC free socket; the lead is stowed in the right-hand case-handle recess.

The TERMINATING UNIT, which will normally be plugged on to the output lead, has two outlets, one of 75 ohms impedance and the other of 52 ohms. Two free plugs are supplied for making connection to the TERMINATING UNIT outlets.

The 20-dB ATTENUATOR PAD, available as an optional accessory, can be inserted between the Generator output socket and the TERMINATING UNIT input plug when low outputs are required.

Details on the use of the TERMINATING UNIT and ATTENUATOR PAD are given in Section 2.6, R.F. OUTPUT ARRANGEMENTS.

Equivalents to the free plugs supplied, and illustrated in Fig. 2.3, are as follows:—

75 ohm      50 ohm

Great Britain,

Air Ministry:	10H/20946	10H/20935
Films and Equipment:	UG-260/U	UG-88/U
Transradio Ltd.:	BN. 1/7	BN. 1/5
Belling and Lee:		L. 1331/FP

United States,

Military No.:	UG-260/U	UG-88/U
---------------	----------	---------

### 2.4 TUNING

The various aspects of tuning the Generator are dealt with in the following sections.

General tuning: Section 2.4.1.

Standardizing frequency against crystal oscillator: Section 2.4.2.

Use of incremental frequency controls: Section 2.4.3.

Interpolation of main frequency scales: Section 2.4.4.

#### 2.4.1 GENERAL TUNING

The TF 995A/5 covers the range 1.5 to 220 Mc/s in five bands as follows:—

Band 1	...	...	1.5 to 13.5 Mc/s
2	...	...	13.5 to 27.5 Mc/s
3	...	...	27 to 55 Mc/s
4	...	...	54 to 110 Mc/s
5	...	...	108 to 220 Mc/s

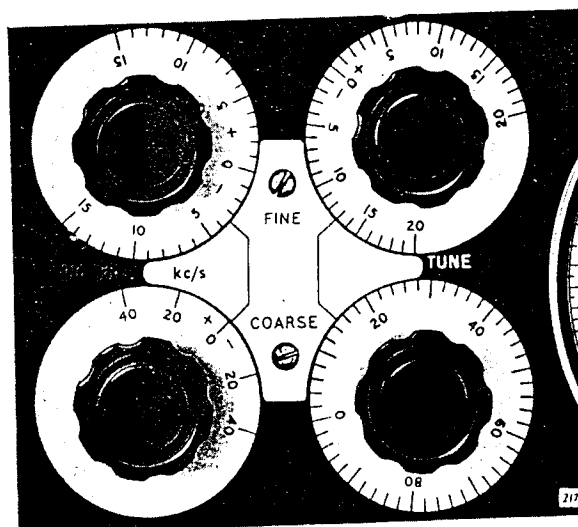

Fig. 2.2 Details of Tuning Arrangements.

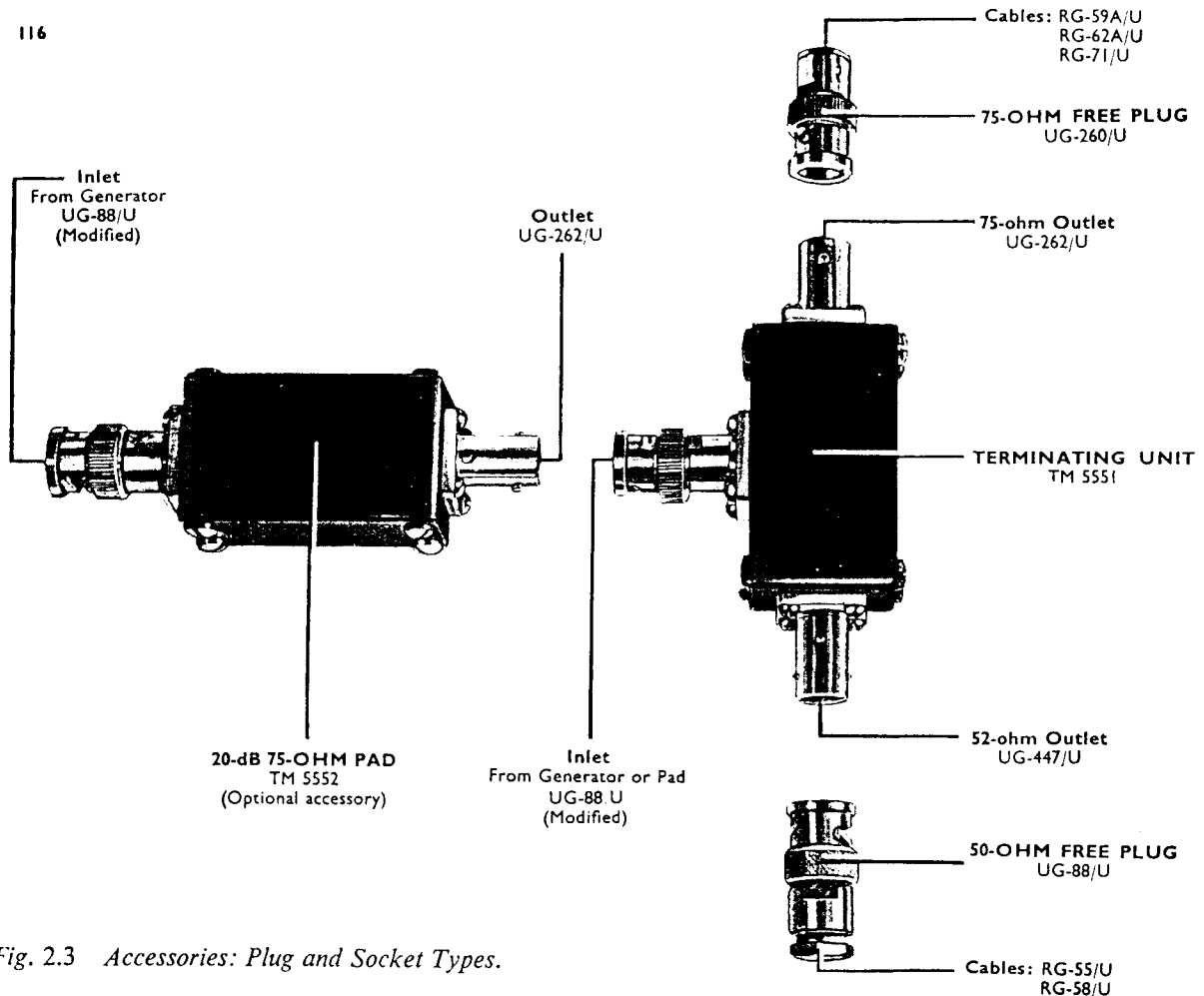

Fig. 2.3 Accessories: Plug and Socket Types.

The particular band required is selected by means of the RANGE switch. Rotation of the COARSE TUNE control varies the output frequency within the limits of the band selected, and moves the main dial relative to its cursor.

The FINE TUNE control has a very small coverage and is incorporated to assist in the precise tuning required in tests involving narrow-band equipment. The total coverage of this control on each band is as follows:—

Band 1	...	...	6 kc/s
2	...	...	3 kc/s
3	...	...	6 kc/s
4	...	...	12 kc/s
5	...	...	24 kc/s

The Signal Generator has a built-in crystal calibrator, and the cursor of the main tuning dial is mounted so that its angular position relative to that of the dial is variable over a small arc by movement of a milled boss at the centre of the dial. This movable cursor enables the operator to

standardize the frequency scale of the Signal Generator at any time; the cursor is used in conjunction with the crystal calibrator in the manner described in Section 2.4.2.

In addition to the RANGE switch and the TUNE controls, the instrument is fitted with calibrated incremental-frequency controls; the method of using these controls is described fully in Section 2.4.3. Section 2.4.4 deals with the method of interpolating between main dial markings by means of the linearly calibrated dial on the COARSE TUNE control.

## 2.4.2 USE OF THE CRYSTAL CALIBRATOR

### (a) Description

Accurate calibration of the main tuning dial may be effected with the built-in crystal oscillator. This oscillator has a fundamental frequency of 333.3 kc/s with an accuracy of 2 parts in  $10^4$  and is coupled to the basic 4.5- to 9.16-Mc/s r.f. oscillator which drives the multiplier chain. The calibrator circuit

is automatically brought into use when a pair of high-resistance headphones are plugged into the CRYSTAL CHECK jack socket; with the aid of the headphones, the difference frequency between the basic oscillator and the harmonic multiples of the calibrator's 333.3 kc/s can be monitored aurally.

Because the outputs on the four higher-frequency bands are all derived directly from the multiplier chain, their frequencies have an exact integral relationship to the frequency of the basic oscillator. It follows, therefore, that setting the COARSE TUNE control to bring the basic-oscillator frequency to that of a crystal harmonic will also bring the frequency of the outputs from the multiplier chain to a known relationship with the crystal harmonic, and allow the frequency dial to be standardized with a high degree of accuracy.

Outputs on the lowest-frequency band are not derived directly from the multiplier chain; their generation involves a heterodyne action between the 27- to 55-Mc/s multiplier and a 30-Mc/s fixed oscillator which is not locked to the basic oscillator. For this reason, although use is made of the crystal calibrator when setting up for 1.5- to 13.5-Mc/s outputs, the accuracy of standardization is of a lower order than that obtained on the four higher-frequency bands.

#### (b) Check-Point Frequencies

The calibrator provides a total of 56 check points between 13.5 and 220 Mc/s; these occur as follows:—

- Band 2, 13.5 to 27.5 Mc/s: at all multiples of 1 Mc/s from 14 to 27 Mc/s inclusive.
- Band 3, 27 to 55 Mc/s: at all multiples of 2 Mc/s from 28 to 54 Mc/s inclusive.
- Band 4, 54 to 110 Mc/s: at all multiples of 4 Mc/s from 56 to 108 Mc/s inclusive.
- Band 5, 108 to 220 Mc/s: at all multiples of 8 Mc/s from 112 to 216 Mc/s inclusive.

#### (c) Standardization Procedure

As shown above, the calibrator allows the frequency scale to be checked at 14 different points on each of the above bands, and the adjustable cursor can be set to correspond exactly with any one of these points.

When the Signal Generator is to be used above 13.5 Mc/s to provide an output at a single spot frequency, or over a narrow band of frequencies, the cursor should be set up at the nearest crystal check point.

When the Signal Generator is to be used over a wide range of frequencies, and it is inconvenient to

reset the cursor for each material frequency change, or, alternatively, when using the 1.5- to 13.5-Mc/s band, the procedure is varied to reduce the mean error to a minimum. The method of standardizing the frequency scale for subsequent general use is as follows:—

- (1) Set the INC. FREQ. controls to zero and the FINE TUNE control to mid-position.
- (2) Set the RANGE switch to 13.5–27 Mc/s.
- (3) Using the headphones plugged into the CRYSTAL CHECK jack, tune the main dial to a crystal check point near the centre of the band; e.g. 20 Mc/s.

When using the calibrator, the MOD. SELECTOR must be set to a position other than INT. MOD.—F.M. or EXT. MOD.—F.M. This ensures that the variable oscillator is not being frequency modulated—a condition which prevents precise setting of the COARSE TUNE control for the lowest-frequency beat note in the headphones, since it gives rise to a fluctuating tone.

After using the calibrator, the Signal Generator can, of course, be set up for f.m. without invalidating this frequency standardization.

- (4) Adjust the milled boss in the centre of the dial to bring the cursor exactly in line with the calibration mark corresponding to the crystal check point.

If the Signal Generator has been out of use for some time, it may be necessary to use a coin in the slot provided in order to rotate the milled boss.

- (5) Check the calibration accuracy at several crystal check points both above and below the check point at which the cursor was set in (4) above.
- (6) Readjust the cursor setting to equalize the errors over the band; e.g. it might be found that, with the frequency scale indication correct at 20 Mc/s, the indication was high at both 15 and 25 Mc/s—in such a case, the errors would be equalized by making the indication a little low at 20 Mc/s, and thus not so high at 15 and 25 Mc/s.

It will be noted that, in the above procedure, the frequency scale is standardized on the 13.5- to 27-Mc/s band. This band is specified since its corresponding scale calibrations occupy the longest arc on the dial. The dial can therefore be read with a high degree of discrimination on this band and the correct cursor setting most easily determined. Once the frequency scale has been standardized on the 13.5- to 27-Mc/s band, the cursor is correctly set to give the minimum mean error on the other three direct-multiple bands. It is also correctly set for the 1.5- to 13.5-Mc/s band.

When standardized in this way, the main tuning dial indication for frequencies above 13.5 Mc/s is accurate to at least 1%, and will generally be within  $\pm 0.5\%$ ; for frequencies below 13.5 Mc/s, the average error does not exceed  $\pm 3\%$ .

### 2.4.3 INCREMENTAL FREQUENCY CONTROLS

These controls are well suited to performing bandwidth or similar measurements since they are a convenient means of producing small, accurately-known changes in carrier frequency. They are not connected directly to the r.f. oscillator either mechanically or electrically, but operate by varying the d.c. potential at the grid of the reactor valve so that they are completely free from backlash of any kind.

To utilize these controls, proceed as follows:—

- (1) With the INC. FREQ. controls set to their centre-zero position, tune the Signal Generator to the required centre-frequency by means of the RANGE switch and the TUNE controls.
- (2) Rotate the INC. FREQ. controls to produce the required shift or the required change in response depending on the method of measurement.

The scales of the INC. FREQ. dials are direct-reading on bands 4 and 5. For each of the other bands, a multiplying factor must be applied, the appropriate factor for each frequency band is engraved on the front panel adjacent to the RANGE switch marking. The multiplying factors are also given below in Table 1.

### 2.4.4 THE INTERPOLATING DIAL

The COARSE TUNE dial is calibrated linearly from 0 to 100 and makes approximately 17 revolutions as the main dial is tuned through a complete band.

This dial may be used to subdivide linearly any part of the frequency scale in order to tune accurately to a frequency which lies between two crystal check points. To do this, proceed as follows:—

- (1) Set the INC. FREQ. controls to zero.
- (2) Set the RANGE switch to whichever of the four higher-frequency bands includes the required frequency.
- (3) Tune the Signal Generator to the nearest crystal check point *below* the required frequency—as indicated on the main tuning dial—identifying the point with the aid of headphones plugged into the CRYSTAL CHECK jack, and noting the interpolating dial reading for the lowest-frequency beat note.
- (4) Tune the Signal Generator to the nearest crystal check point *above* the required frequency and note the change of reading of the interpolating dial. It is important that the *total* change is noted when the dial is turned through more than one revolution.

*The relationship should be determined between the crystal check points which embrace the particular section of the frequency band over which incremental variations are to be made. Also, the relationship should be redetermined for each different section of the frequency band, since it varies, not only from band to band, but also for different sections of any one band.*

- (5) From the difference in frequency between the two crystal check points, and the total number of interpolating dial divisions traversed, calculate the frequency change per interpolating dial division; this change may be conveniently expressed in kc/s per division.
- (6) With the aid of the headphones, reset the main tuning dial to the crystal check point below the required frequency.

TABLE I

RANGE switch setting (Mc/s)	Total coverage of INC. FREQ. controls (kc/s)	Multiply INC. FREQ. dial readings by	Incremental Frequency change per division (kc/s per div)	
			COARSE	FINE
1.5–13.5 (Band 1)	$\pm 27.5$	0.5	10	0.5
13.5–27.5 (Band 2)	$\pm 13.75$	0.25	5	0.25
27–55 (Band 3)	$\pm 27.5$	0.5	10	0.5
54–110 (Band 4)	$\pm 55$	1	20	1
108–220 (Band 5)	$\pm 55$	1	20	1

- (7) Rotate the COARSE TUNE control so that the interpolating dial traverses the correct number of divisions to give the required frequency.

It is recommended that the required frequency should always be approached from the low-frequency side in order to eliminate all possibility of error due to backlash.

The following example illustrates the use of the interpolating dial to obtain an output from the instrument at an accurate frequency of 74.25 Mc/s.

*Example:* With the TUNE control set to the crystal check point at 72 Mc/s, the interpolating dial reading was 17. With the TUNE control set to the crystal check point of 76 Mc/s the new reading on the auxiliary dial was 40. The total number of interpolating dial divisions traversed was 123, the dial having rotated through slightly more than one revolution for the frequency change of 4 Mc/s, i.e. 4,000 kc/s. In this case, a change of 1 division on the interpolating dial corresponded, *between 72 and 76 Mc/s*, to a nominal frequency change of

$$\frac{4,000}{123} = 32.5 \text{ kc/s.}$$

Therefore, by starting from the original auxiliary dial setting at 72 Mc/s (72,000 kc/s) the required frequency of 74.25 Mc/s (74,250 kc/s) was obtained by rotating the auxiliary dial through

$$\frac{74,250 - 72,000}{32.5} = \frac{2,250}{32.5} = 69 \text{ divisions.}$$

Since it will be appreciated that only typical figures could be quoted above, it follows that the relationship between frequency change and change

in interpolating dial setting should be determined—in the manner outlined above—for the particular TF 995A/5 in use.

## 2.5 SETTING UP FOR C.W. OR MODULATED OUTPUT

The Signal Generator will give the following types of r.f. output:—

- (1) Continuous wave (see Section 2.5.1).
- (2) Amplitude modulated (see Section 2.5.2), variable to 50% depth,
  - (a) from the internal a.f. oscillator at 400, 1,000, or 1,500 c/s,
  - (b) from an external sinewave source, within the range 100 c/s to 10 kc/s.
- (3) Frequency modulated (see Section 2.5.3), variable to maximum frequency deviations ranging from 15 kc/s to 120 kc/s,
  - (a) from the internal a.f. oscillator at 400, 1,000, or 1,500 c/s,
  - (b) from an external sinewave source, within the range 50 c/s to 15 kc/s.
- (4) Simultaneous frequency and amplitude modulation (see Section 2.5.4); the amplitude modulation being obtained from the internal a.f. oscillator, and the frequency modulation from an external source as (3) (b), above.

When setting up for amplitude or frequency modulation as described in Sections 2.5.2 and 2.5.3, it may be observed that, with the METER READS key held to either A.M. or F.M. as applies, the apparent modulation as measured on external apparatus is

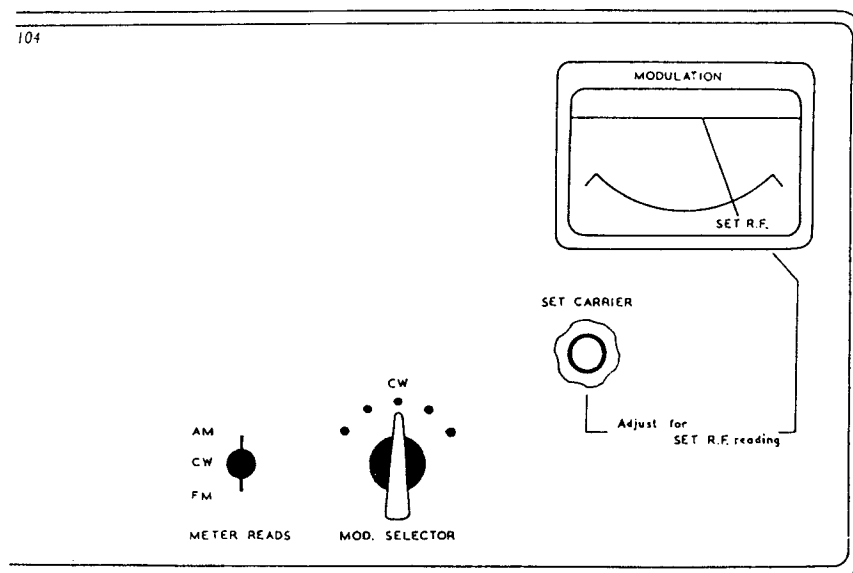

Fig. 2.4 C.W. Operation.

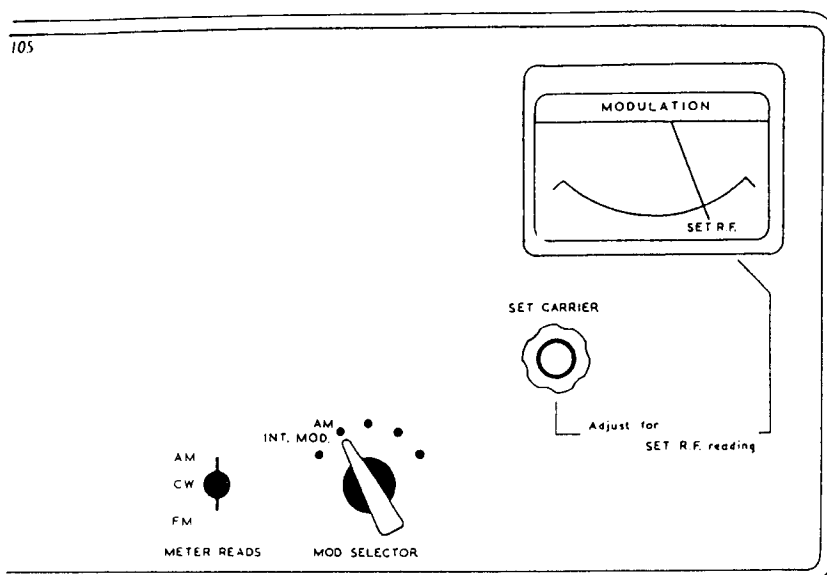

Fig. 2.5 (a)  
Internal A.M. Operation.  
(i) Setting Carrier Level.

less than that indicated on the meter. This is quite in order; the meter indicates the modulation which will be obtained when the switch is returned to its central position and the meter reverts to its normal function of monitoring the r.f. level.

### 2.5.1 CONTINUOUS WAVE

- (1) Set the MOD. SELECTOR switch to C.W.
- (2) Adjust the SET CARRIER control to bring the meter pointer to the SET R.F. mark.

### 2.5.2 AMPLITUDE MODULATION

#### (a) From the internal 3-frequency oscillator

- (1) Set the MOD. SELECTOR switch to INT. MOD.—A.M.
- (2) Turn the SET MOD. FREQ. switch to give the

required modulation frequency—400, 1,000, or 1,500 c/s.

- (3) Adjust the SET CARRIER control to bring the meter pointer to the SET R.F. mark.
- (4) With the METER READS key switch held in the A.M. position, adjust the SET MOD. control to the required modulation depth, as indicated on the top scale of the panel meter. Amplitude modulation is variable to a maximum depth of 50%.
- (5) Release the METER READS key switch and, if necessary, repeat (3) above.

#### (b) From an external a.f. source

- (1) Set the MOD. SELECTOR switch to EXT. MOD.—A.M.

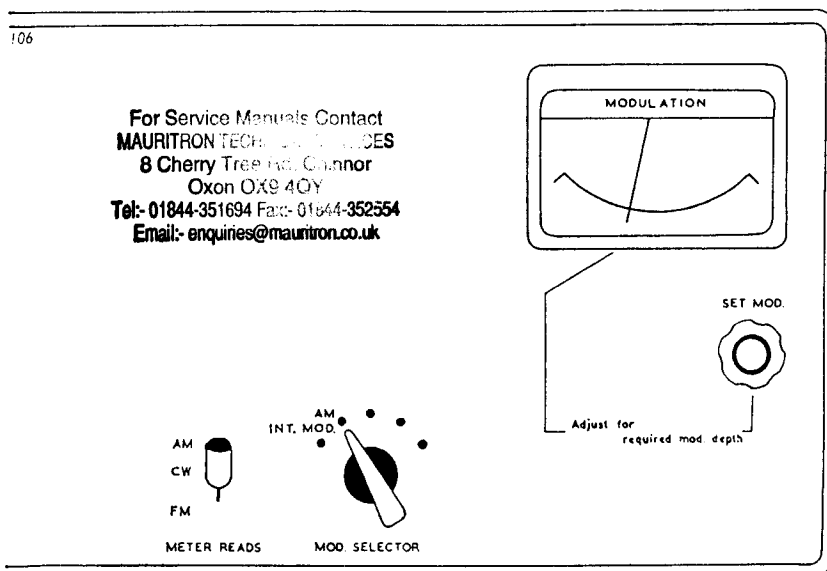
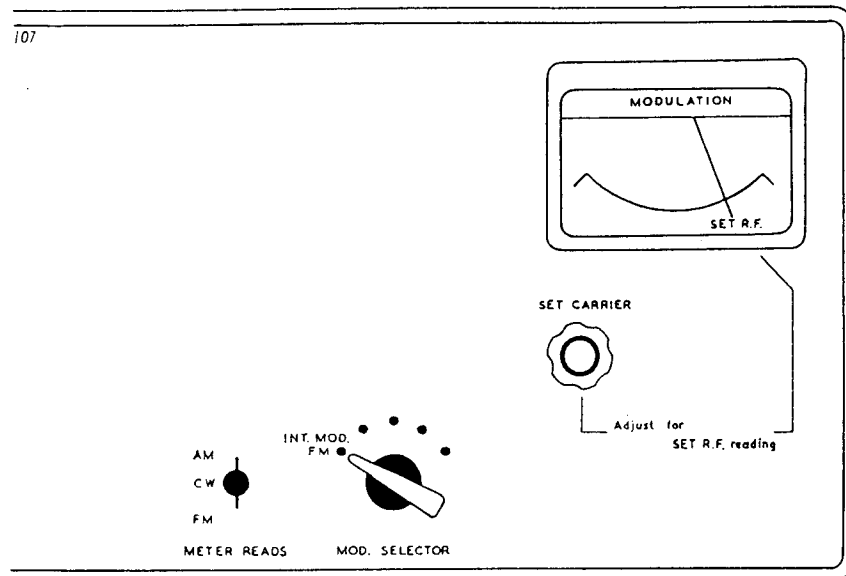

Fig. 2.5 (b)  
Internal A.M. Operation.  
(ii) Setting Modulation Depth.

Fig. 2.6 (a)  
Internal F.M. Operation.  
(i) Setting Carrier Level.



- (2) Adjust the SET CARRIER control to bring the meter pointer to the SET R.F. mark.
- (3) Connect the external modulation source to the EXT. MOD. and E terminals.
- (4) With the METER READS key switch held in the A.M. position, adjust the SET MOD. control to the required modulation depth, as indicated on the top scale of the panel meter. With the SET MOD. control at maximum, an input of approximately 15 volts r.m.s. is required at the EXT. MOD. and E terminals to produce 30% modulation depth within the modulation frequency range 100 c/s to 10 kc/s.
- (5) Release the METER READS key switch and, if necessary, repeat (2) above.

### 2.5.3 FREQUENCY MODULATION

In addition to the MOD. SELECTOR switch, there are three other controls concerned in setting up the carrier deviation when the output from the Signal Generator is to be frequency modulated. These controls are the continuously-variable SET MOD. potentiometer, the DEVIATION RANGE switch, and the DEVIATION—NORMAL/HIGH switch. When the METER READS key switch is held to F.M., the panel meter indicates deviation. The meter has two deviation scales: one calibrated from 0 to 5 kc/s, and the other from 0 to 15 kc/s.

With the DEVIATION—NORMAL/HIGH switch set to NORMAL, the meter scale appropriate to the setting of the DEVIATION RANGE switch is used and the

Fig. 2.6 (b)  
Internal F.M. Operation.  
(ii) Setting Deviation.

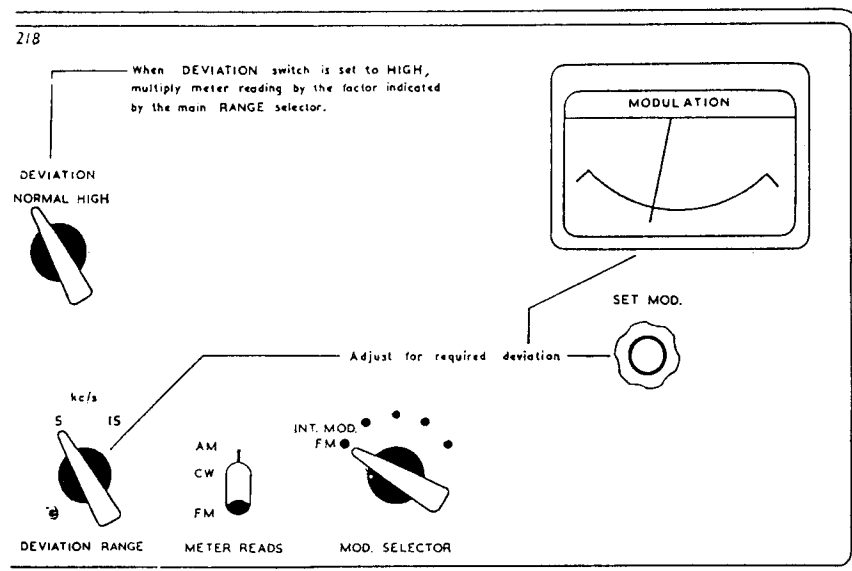



TABLE 2

RANGE switch setting (Mc/s)	DEVIATION RANGE switch setting (kc/s)	DEVIATION—NORMAL/HIGH switch set to HIGH		
		Multiply meter reading by	Maximum deviation obtainable (kc/s)	
1.5–13.5 (Band 1)	{ 5 15	2 2	10 30	
For Service Manuals Contact MAURITRON TECHNICAL SERVICES 8 Cherry Tree Rd, Chinnor Oxon OX9 4QY Tel: 01844-351694 Fax: 01844-352354 Email: enquiries@mauritron.co.uk	13.5–27.5 (Band 2)	{ 5 15	1 1	5 15
	27–55 (Band 3)	{ 5 15	2 2	10 30
	54–110 (Band 4)	{ 5 15	4 4	20 60
	108–220 (Band 5)	{ 5 15	8 8	40 120

deviation is as indicated by the meter for all settings of the carrier-frequency RANGE switch.

With the DEVIATION—NORMAL/HIGH switch set to HIGH, the deviation obtained on the 13.5- to 27-Mc/s band is the same as with the switch set to NORMAL. For all other carrier-frequency bands the deviation is increased and the meter readings—again taken on the scale appropriate to the settings of the DEVIATION RANGE switch—must be multiplied in accordance with Table 2 above.

The following example shows the method of determining the meter reading for a required deviation greater than 15 kc/s and thus necessitates setting the DEVIATION—NORMAL/HIGH switch to HIGH.

*Example: A deviation of 36 kc/s is required at a carrier frequency of 80 Mc/s.*

The carrier frequency lies within the 54- to 110-Mc/s band. The meter multiplying factor for this band is 4; therefore, for 36-kc/s deviation, the meter should be set (by means of the SET MOD. control) to read

$$\frac{36}{4} = 9 \text{ kc/s.}$$

Do this on the bottom scale of the meter with the DEVIATION RANGE switch set to 15 kc/s.

#### (a) F.M. from the internal 3-frequency oscillator

- (1) Set the MOD. SELECTOR switch to INT. MOD.—F.M.
- (2) Turn the SET MOD. FREQ. switch to give the required modulation frequency—400, 1,000, or 1,500 c/s.
- (3) Set the DEVIATION RANGE switch as required. If, at carrier frequencies less than 13.5 Mc/s, or greater than 27.5 Mc/s, more than 15 kc/s deviation is required, set the DEVIATION—

NORMAL/HIGH switch to HIGH. (Deviations greater than 15 kc/s are not obtainable on the 13.5- to 27.5-Mc/s carrier-frequency band, the maximum deviations obtainable on the other carrier-frequency bands are given in Table 2.)

- (4) Adjust the SET CARRIER control to bring the meter pointer to the SET R.F. mark.
- (5) With the METER READS key switch held to F.M., adjust the SET MOD. control until the required deviation is indicated on the panel meter; read the meter on its middle scale when the DEVIATION range switch is at 5 kc/s, and read on the lower scale when the switch is at 15 kc/s. If the DEVIATION—NORMAL/HIGH switch is set to HIGH, the meter readings must be multiplied by the appropriate factor given in Table 2.
- (6) Release the METER READS key switch and, if necessary, repeat (5) above.

#### (b) F.M. from an external source

- (1) Set the MOD. SELECTOR switch to EXT. MOD.—F.M.
- (2) Set the DEVIATION RANGE switch as required. If at carrier frequencies less than 13.5 Mc/s, or greater than 27.5 Mc/s, more than 15 kc/s deviation is required, set the DEVIATION—NORMAL/HIGH switch to HIGH. (Deviations greater than 15 kc/s are not obtainable on the 13.5- to 27.5 Mc/s carrier-frequency band; the maximum deviations obtainable on the other carrier-frequency bands are given in Table 2.)
- (3) Adjust the SET CARRIER control to bring the meter pointer to the SET R.F. mark.
- (4) Couple the external modulation source to the EXT. MOD. and E terminals.
- (5) With the METER READS key switch held to F.M., adjust the SET MOD. control until the required deviation is indicated on the panel meter; read

the meter on its middle scale when the DEVIATION RANGE switch is set to 5 kc/s, and read on the lower scale when the switch is set to 15 kc/s. If the DEVIATION—NORMAL/HIGH switch is set to HIGH, the meter readings must be multiplied by the appropriate factor given in Table 2.

For any settings of the DEVIATION RANGE and DEVIATION—NORMAL/HIGH switches, and within the modulation frequency range 50 c/s to 15 kc/s, approximately 25 volts r.m.s. is required between the EXT. MOD. and E terminals for full deviation. With respect to 1 kc/s, the frequency characteristic of the modulation system is flat to within  $\pm 1$  dB from 50 c/s to 15 kc/s.

#### 2.5.4 SIMULTANEOUS FREQUENCY AND AMPLITUDE MODULATION

- (1) Set up the required depth of amplitude modulation as detailed in Section 2.5.2 (a).
- (2) Leaving the MOD. SELECTOR switch at INT. MOD.—A.M., and without altering the setting of the SET MOD. control, set up the required deviation in a similar manner to that detailed in Section 2.5.3 (b); in this case, adjust the amount of deviation by variation of the audio input from the external modulation source.

#### 2.6 R.F. OUTPUT ARRANGEMENTS

Five factors affect the output level from the Signal Generator:—

- (a) The SET CARRIER control whose setting determines the input level to the attenuator cascade.
- (b) The 'coarse' or OUTPUT VOLTAGE attenuator.
- (c) The 'fine' or MULTIPLY BY attenuator.
- (d) The TERMINATING UNIT which plugs on the end of the output cable from the fine attenuator.
- (e) ATTENUATOR PAD Type TM 5552, which is an optional accessory designed for insertion between the output cable and TERMINATING UNIT when especially low output levels are required.

The SET CARRIER control is adjusted in conjunction with the panel meter; with the METER READS key switch in its central position, the panel meter forms part of a crystal voltmeter which monitors the input to the coarse attenuator. The panel meter has three main marks on its scale; these marks are  $-1$  dB, SET R.F., and  $+1$  dB, respectively. Normally, the SET CARRIER control should be adjusted to bring the meter pointer to the SET R.F. mark.

Four 20-dB steps give the coarse or OUTPUT VOLTAGE attenuator a total range of 80 dB; each setting of the attenuator control has markings in

yellow and in white, the yellow markings being in decibels relative to  $1 \mu\text{V}$ ; the white markings are directly in units of voltage.

Ten 2-dB steps give the fine or MULTIPLY BY attenuator a total range of 20 dB; each setting of the attenuator control has markings in yellow and white, the yellow markings being in terms of decibels relative to  $1 \mu\text{V}$ , and the white markings multiplying factors for the white voltage markings on the coarse attenuator.

Both attenuators have a characteristic impedance of 75 ohms and, 'looking into' the coaxial socket at the end of the output cable, the instrument appears as a generator with a source impedance of 75 ohms at all attenuator settings.

The TERMINATING UNIT is, essentially, a 6-dB attenuator pad; 'looking into' its input socket, with its output sockets unterminated, the TERMINATING UNIT presents an impedance of 75 ohms, while the two outlets present impedances of 52 and 75 ohms respectively.

The ATTENUATOR PAD has a characteristic impedance of 75 ohms and provides an optional, additional, 20-dB attenuation of the output signal.

It should be noted particularly that the r.f. output controls on the Signal Generator are calibrated in terms of source e.m.f. or open-circuit output voltage. The significance of quoting the output of a signal generator in this way will be apparent when it is remembered that one of the primary functions of a signal generator is to simulate a received signal as it would come from an aerial.

To take a simple case—that in which a 75-ohm receiver is fed from a 75-ohm dipole—the e.m.f. induced in the aerial is shared between its inherent 75-ohm radiation resistance and the matched 75-ohm receiver input. Clearly, when the same receiver is fed from a signal generator, the corresponding signal strength is given by the source e.m.f. of the signal generator, and not by the on-load p.d. at the receiver terminals.

#### 2.6.1 OUTPUTS FROM $1 \mu\text{V}$ TO 100 mV AT 52 AND 75 OHMS

It is intended that the Signal Generator should normally be used with the SET CARRIER control adjusted to bring the meter pointer to the SET R.F. mark; with the TERMINATING UNIT coupled directly to the output cable; and without the ATTENUATOR PAD Type TM 5552.

Used in this way, the Signal Generator should be regarded as a source of zero impedance in series with a resistance of either 75 ohms or 52 ohms, the open-circuit output level, or source e.m.f., being variable in 2-dB steps from  $1 \mu\text{V}$  to 100 mV and being given:

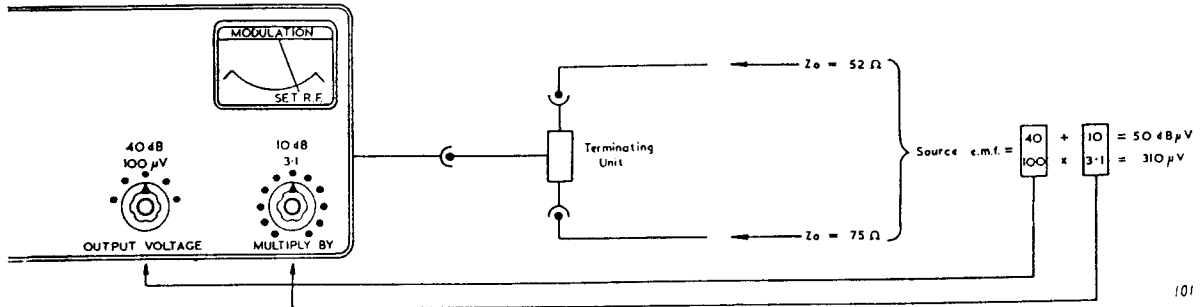

Fig. 2.7 Outputs via Terminating Unit.

- (a) directly in terms of decibels relative to 1 μV, by the sum of the yellow settings of the OUTPUT VOLTAGE and MULTIPLY BY attenuators;
- (b) directly in voltage, by the product of the white settings of the OUTPUT VOLTAGE and MULTIPLY BY attenuators.

The +1-dB and -1-dB marks on the panel meter allow interpolation between the 2-dB steps of the MULTIPLY BY attenuator. Setting the meter pointer to either the +1-dB or -1-dB mark increases or decreases the input to the attenuator cascade by 1 decibel. Thus, using the SET CARRIER control and panel meter in conjunction with the OUTPUT VOLTAGE and MULTIPLY BY attenuators, the output level from the Signal Generator can be varied in 1-dB steps over the range 0 to +100 dB relative to 1 μV.

It should be noted that the white voltage indication given by the attenuator controls is not directly applicable when the meter is set to other than the SET R.F. mark; with the meter at -1 dB, the source e.m.f. at the TERMINATING UNIT outlets is 0.89 of the indicated voltage; with the meter at +1 dB, the source e.m.f. is 1.12 of the indicated voltage.

**2.6.2 OUTPUTS FROM 2 μV TO 200 mV AT 75 OHMS ONLY**

With the TERMINATING UNIT detached and with the meter at the SET R.F. mark, the output level

obtained directly from the plug at the end of the r.f. output cable is variable in the range 2 μV to 200 mV and is derived via a source impedance of 75 ohms.

Under these conditions, the open-circuit level, or source e.m.f., in terms of decibels relative to 1 μV is obtained by adding 6 dB to the sum of the meter reading and the yellow indications of the OUTPUT VOLTAGE and MULTIPLY BY attenuators; the source e.m.f. is given directly in voltage by doubling the product of the white indications of the OUTPUT VOLTAGE and MULTIPLY BY attenuators.

**2.6.3 OUTPUTS FROM 0.1 μV TO 10 mV AT 52 AND 75 OHMS**

With the TERMINATING UNIT coupled to the r.f. output cable via the optional 20-dB ATTENUATOR PAD and with the meter at the SET R.F. mark, the output level from the TERMINATING UNIT is variable in the range 0.1 μV (nominal) to 10 mV.

In this case, the source e.m.f. in terms of decibels relative to 1 μV is obtained by subtracting 20 dB from the sum of the meter reading and the yellow indications of the OUTPUT VOLTAGE and MULTIPLY BY attenuators; the source e.m.f. is given directly in voltage by dividing the product of the white indications of the OUTPUT VOLTAGE and MULTIPLY BY attenuators by 10.

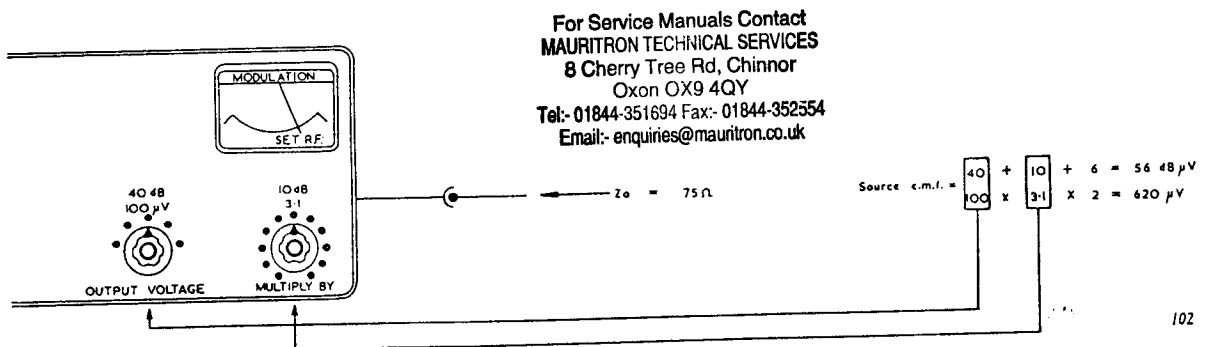

Fig. 2.8 Output Direct from Output Lead.

For Service Manuals Contact  
**MAURITRON TECHNICAL SERVICES**  
 8 Cherry Tree Rd, Chinnor  
 Oxon OX9 4QY  
 Tel:- 01844-351694 Fax:- 01844-352554  
 Email:- enquiries@mauritron.co.uk

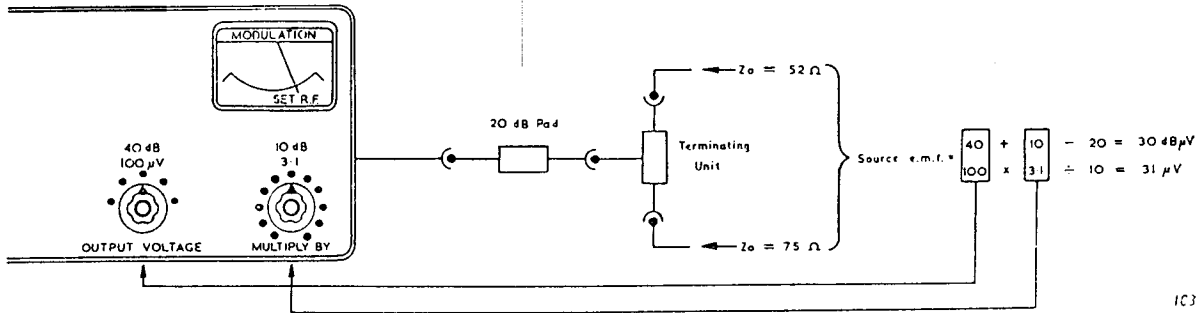

Fig. 2.9 Outputs via 20-dB Pad and Terminating Unit.

### 2.6.4 OUTPUT IN TERMS OF VOLTAGE DEVELOPED ACROSS AN EXTERNAL LOAD

For some particular applications, it may be desired to work not in terms of source e.m.f. as indicated by the meter and attenuator controls, but in terms of actual voltage developed across the external load. This on-load, or terminal voltage, is given by the expression

$$V_L = E \times \frac{Z_L}{Z_0 + Z_L} \quad \text{.....(1)}$$

where  $V_L$  = actual voltage developed across the external load.

$E$  = the source e.m.f. of the Signal Generator.

$Z_L$  = the impedance of the external load.

$Z_0$  = the source impedance of the Signal Generator; (with the TERMINATING UNIT in use,  $Z_0 = 75$  or  $52 \Omega$ ; with the TERMINATING UNIT removed,  $Z_0 = 75 \Omega$ ).

A series of multiplying factors, which can be used to convert from source e.m.f. to actual voltage developed across an external resistive load, and which have been derived with the aid of the above expression, are given in Table 3 for a selection of typical load values.

### 2.6.5 MATCHING TO EXTERNAL LOADS OTHER THAN 52 OR 75 OHMS

The TERMINATING UNIT supplied with the Signal Generator allows r.f. outputs to be obtained from a source impedance of either 52 or 75 ohms.

If the equivalent under test has an input impedance of other than 52 or 75 ohms, and if it is required to present the equipment with a signal derived from a matched source, then it is necessary to modify the output arrangements of the Signal Generator. The simple modifications required are described in sub-sections (a) and (b) which follow.

These expressions are based on the assumption that the external load impedance  $Z_L$  is essentially resistive. Where  $Z_L$  is not essentially resistive, it may be necessary for the user to revise these expressions to take account of the reactive component of the load.

In these sub-sections it is assumed that the TERMINATING UNIT is in circuit, and that the 20-dB ATTENUATOR PAD is out of circuit.

(a) External load less than that of the TERMINATING UNIT outlet in use.

The impedance presented to the load can be made equal to the load impedance by shunting the TERMINATING UNIT outlet with a single resistor,  $R_p$ , where

$$R_p = \frac{Z_0 \times Z_L}{Z_0 - Z_L} \quad \text{.....(2)}$$

TABLE 3

External load impedance in ohms	Approximate multiplying factor to convert from source e.m.f. to actual voltage developed across an external resistive load	
	$Z_0 75 \Omega$	$Z_0 52 \Omega$
10	0.12	0.16
20	0.21	0.28
30	0.29	0.36
40	0.35	0.43
50	0.4	0.49
52	0.41	0.5
60	0.44	0.53
70	0.48	0.57
75	0.5	0.59
80	0.51	0.61
100	0.57	0.65
150	0.67	0.74
200	0.73	0.79
300	0.8	0.85
600	0.89	0.92

114

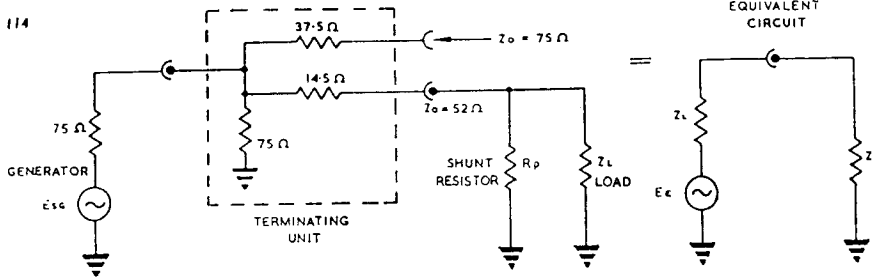

Fig. 2.10  
Matching to  
Low-Impedance Loads.

and where  $Z_0$  = the source impedance of the Signal Generator at the TERMINATING UNIT outlet in use;

$Z_L$  = the impedance of the external load.

Under these conditions, the relationship between  $E_{SG}$ , the e.m.f. indicated by the attenuator controls on the Signal Generator, and  $E_E$ , the effective source e.m.f. presented to the external load, is given by the expression

$$E_{SG} = E_E \times \frac{R_p + Z_0}{R_p} \dots\dots\dots(3)$$

*Example:* It is required to provide a signal of  $25 \mu V$  effective source e.m.f. at a source impedance of 20 ohms.

Since the new source impedance is to be 20 ohms, the output is taken from the 52-ohm outlet on the TERMINATING UNIT, the 52-ohm outlet being chosen in preference to the 75-ohm outlet to obtain the minimum reduction from  $E_{SG}$  to  $E_E$ .

From expression (2), the value of  $R_p$  to be connected in parallel with the 52-ohm outlet of the TERMINATING UNIT is

$$\frac{52 \times 20}{52 - 20} = 32.5 \Omega.$$

From expression (3), the attenuator controls on the Signal Generator should be set to indicate

$$25 \times \frac{32.5 + 52}{32.5} = 65 \mu V.$$

The attenuators cannot be set to indicate exactly  $65 \mu V$  and they should therefore be set to  $63 \mu V$ —the setting nearest to the required value for  $E_{SG}$ .  $63 \mu V$  is approximately  $-0.3$  dB relative to  $65 \mu V$  and, if desired, the user may obtain an  $E_{SG}$  nearer to  $65 \mu V$  by adjustment of the SET CARRIER control

to bring the meter pointer to an estimated  $+0.3$  dB.

As a result of shunting the output of the TERMINATING UNIT with 32.5 ohms and setting the attenuator controls in the manner described, the equipment under test is fed from a source whose effective output impedance is 20 ohms and whose effective source e.m.f. is  $25 \mu V$ ; the actual voltage developed across the input impedance of the equipment under test is, of course,  $12.5 \mu V$ .

(b) External load greater than that of the TERMINATING UNIT outlet in use.

The impedance presented to the load can be made equal to the load impedance by connecting a single resistor,  $R_S$ , in series with the Signal Generator output. The value of  $R_S$  is given by the expression

$$R_S = Z_L - Z_0 \dots\dots\dots(4)$$

where  $Z_L$  = the impedance of the external load.

$Z_0$  = the source impedance of the Signal Generator at the TERMINATING UNIT outlet in use.

Under these conditions, the effective source e.m.f. ( $E_E$ ) of the Signal Generator and series resistor combined, equals the source e.m.f. ( $E_{SG}$ ) of the Signal Generator alone, i.e.

$$E_{SG} = E_E \dots\dots\dots(5)$$

*Example:* It is required to provide a signal of  $10 \mu V$  effective source e.m.f. at a source impedance of 300 ohms.

Since the new output impedance is greater than either 52 or 75 ohms, there is no advantage to be gained by using one of the TERMINATING UNIT outlets in preference to the other; in this example it is assumed that the 75-ohm outlet is used.

113

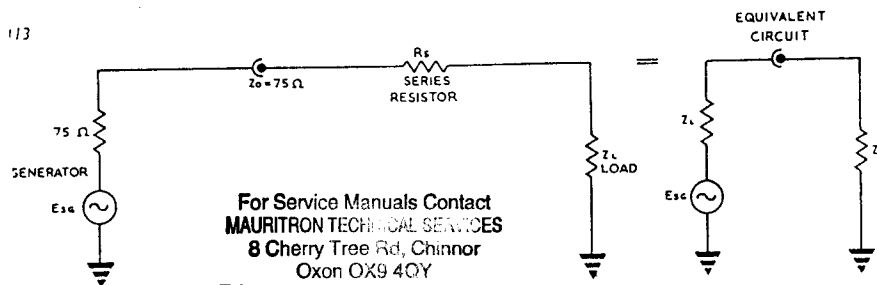
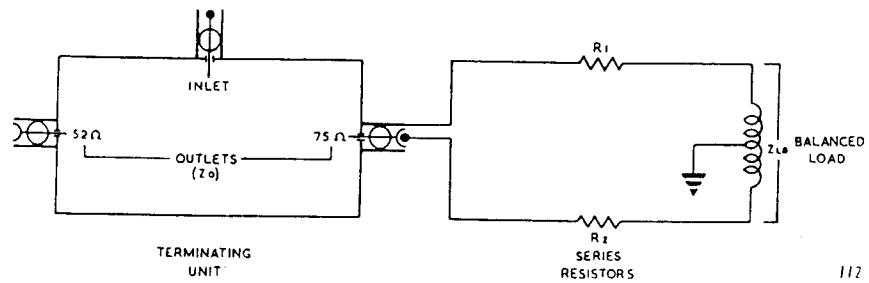

Fig. 2.11  
Matching to  
High-Impedance Loads.

For Service Manuals Contact  
**MAURITRON TECHNICAL SERVICES**  
8 Cherry Tree Rd, Chinnor  
Oxon OX9 4QY  
Tel: 01844-351694 Fax: 01844-352354  
Email: enquiries@mauriron.co.uk

Fig. 2.12  
Matching to  
Balanced Loads.



117

From expression (4) the value of  $R_S$  to be connected in series with the 'live' connection between the Signal Generator and the equipment under test, is

$$300 - 75 = 225 \Omega.$$

From expression (5), the attenuators on the Signal Generator should be set to indicate

$$10 \mu\text{V}.$$

In this way, the equipment under test is fed from a source whose effective impedance is 300 ohms and whose effective source e.m.f. is  $10 \mu\text{V}$ ; the actual voltage developed across the input impedance of the equipment under test is, of course,  $5 \mu\text{V}$ .

## 2.6.6 MATCHING TO BALANCED LOADS

The preceding Sections dealing with r.f. output arrangements are based on the supposition that the equipment being fed from the Signal Generator has an unbalanced input circuit.

With certain types of equipment, the input circuit is in the form of a balanced winding; such equipment can be fed from the unbalanced output of the Signal Generator by interposing two loading resistors between the TERMINATING UNIT outlet and the ends of the balanced input winding. This method makes use of the auto-transformer effect of the centre-tapped winding, and is *not* suitable for resistive balanced inputs.

One resistor,  $R_1$ , is connected in series between the earth connection of the TERMINATING UNIT outlet in use and one side of the balanced winding; the other resistor,  $R_2$ , is connected in series between the 'live' connection of the TERMINATING UNIT outlet in use and the other side of the balanced winding.

Values for  $R_1$  and  $R_2$  may be computed from the following expressions:

$$R_1 = \frac{Z_{LB}}{2} \quad \dots\dots(6)$$

$$R_2 = \frac{Z_{LB}}{2} - Z_0 \quad \dots\dots(7)$$

where  $Z_{LB}$  = the total line-to-line impedance of the balanced winding.

$Z_0$  = the source impedance of the Signal Generator at the TERMINATING UNIT outlet in use.

With the equipment under test and the TERMINATING UNIT of the Signal Generator interconnected via  $R_1$  and  $R_2$  as described above, the source e.m.f. ( $E_{SG}$ ) indicated by the Signal Generator controls is equal to the effective line-to-line source e.m.f. ( $E_E$ ) 'seen' by the equipment under test.

*Example:* It is required to match the 75-ohm outlet to a balanced winding whose total line-to-line impedance is 200 ohms.

From expression (6), the value of  $R_1$  is

$$\frac{200}{2} = 100 \Omega.$$

From expression (7), the value of  $R_2$  is

$$\frac{200}{2} - 75 = 25 \Omega.$$

$R_1$  is connected in series with the earth connection of the TERMINATING UNIT and one side of the balanced winding;  $R_2$  is connected in series with the 'live' connection between the TERMINATING UNIT and the other side of the balanced winding.

## 2.7 SYNCHRONIZING SIGNAL

An audio sinewave signal, derived from the internal a.f. oscillator, is available between the SYNC and E terminals of the instrument when the MOD. SELECTOR switch is set at either of the INT. MOD. positions. The frequency of the signal will depend on the setting of the SET MOD. FREQ. switch; it has an open-circuit level which varies from about 30 volts at 400 c/s to about 100 volts at 1500 c/s, and is derived via a source impedance of approximately 250 k $\Omega$ .

When an output from the equipment under test is being viewed on a cathode-ray oscilloscope, it will often be found convenient to lock the c.r.o. time base directly with the SYNC signal rather than with the actual signal being viewed.

The SYNC output can, of course, also be used when an audio-frequency signal is required for the equipment under test.

## 3 OPERATIONAL SUMMARY

When the user is familiar with the principles and techniques of operation detailed in Section 2 of this handbook, the following abridged operating instructions may be found convenient.

*Check correctness of mains transformer tapings before use.*

### STANDARDIZING THE FREQUENCY SCALE

Switch mains ON and set RANGE switch to 13.5–27.5; with MOD. SELECTOR switch set to other than INT. MOD.—F.M. or EXT. MOD.—F.M., and using headphones plugged into CRYSTAL CHECK socket, tune main dial to crystal check point near centre of band. Bring movable cursor in line with dial calibration corresponding to crystal check point. Check accuracy of frequency indication above and below point to which cursor was originally set, equalize errors over band by readjusting cursor. *See Section 2.4.2.*

### TUNING

Set RANGE switch to band required; rotate TUNE control until cursor indicates required frequency. For higher frequency-accuracy, compute relationship of frequency change to change in auxiliary dial setting between crystal check points or scale markings embracing required frequency. Starting from selected point below required frequency, rotate TUNE control so that incremental dial traverses calculated number of divisions. *See Sections 2.4.1 and 2.4.4.*

### INCREMENTAL FREQUENCY ADJUSTMENT

Make small carrier changes by means of INC. FREQ. control, using multiplying factors as shown on front panel. *See Section 2.4.3.*

### C.W. OPERATION

With MOD. SELECTOR switch set to C.W., adjust SET CARRIER to bring meter pointer to SET R.F.; adjust step attenuators to obtain required output level. *See Section 2.5.1.*

### AMPLITUDE MODULATION

#### Internal:

With MOD. SELECTOR switch at INT. MOD.—A.M., select required modulation frequency on SET

MOD. FREQ. switch, adjust SET CARRIER to bring meter pointer to SET R.F. With METER READS switch at A.M., adjust SET MOD. to bring meter pointer to required modulation depth. Release METER READS switch and, if necessary, readjust SET CARRIER; adjust step attenuators to obtain required output level.

#### External:

As for internal, except that MOD. SELECTOR switch is set to EXT. MOD.—A.M.; SET MOD. FREQ. switch is inoperative, and external signal is injected between EXT. MOD. and E terminals. Approximately 15 volts r.m.s. (100 c/s to 10 kc/s) is required to produce 30% modulation. *See Section 2.5.2.*

### FREQUENCY MODULATION

#### Internal:

With MOD. SELECTOR switch at INT. MOD.—F.M., select required modulation frequency on SET MOD. FREQ. switch. Set DEVIATION RANGE switch as required, and adjust SET CARRIER control to bring meter pointer to SET R.F. With METER READS switch at F.M., adjust SET MOD. to bring meter pointer to required deviation on meter scale appropriate to DEVIATION RANGE switch setting. (For deviations greater than 15 kc/s, set DEVIATION—NORMAL/HIGH switch to HIGH and multiply meter readings by factor given in Table 2, Section 2.5.3.) Release METER READS switch and, if necessary, readjust SET CARRIER; adjust step attenuators to obtain required output level.

#### External:

As for internal, except that MOD. SELECTOR switch is set to EXT. MOD.—F.M., SET MOD. FREQ. switch is inoperative, and external signal is injected between EXT. MOD. and E terminals. Approximately 25 volts r.m.s. (50 c/s to 15 kc/s) is required to produce full deviation. *See Section 2.5.3.*

### SIMULTANEOUS FREQUENCY AND AMPLITUDE MODULATION

Set up as for Amplitude Modulation Internal. Then, with MOD. SELECTOR switch still set at INT. MOD.—A.M., apply external signal (50 c/s to 15 kc/s) between EXT. MOD. and E terminals. Adjust level of external signal to produce required deviation; do not readjust SET MOD. control. *See Section 2.5.4.*

# 4 TECHNICAL DESCRIPTION

## 4.1 R.F. CIRCUITS

The r.f. oscillator itself (V3) is variable only over a fundamental frequency range of 4.5 to 9.16 Mc/s; the four higher frequency bands are obtained from a chain of four ganged harmonic multipliers (V6, V8, V10, and V12) giving multiplying factors of  $\times 3$ ,  $\times 2$ ,  $\times 2$ , and  $\times 2$  respectively. The setting of the frequency RANGE switch determines which of the multipliers acts as the output stage. Output over the 1.5- to 13.5-Mc/s band is obtained by applying the 27- to 55-Mc/s output of the second multiplier to a single valve circuit (V7a) which combines the functions of mixer and 30-Mc/s oscillator. The variable-frequency output from the second multiplier is thus heterodyned with a fixed 30-Mc/s signal, and the output from the oscillator/mixer stage contains a difference-frequency component which is utilized—after filtering and amplification (by V7b)—to provide outputs between 1.5 and 13.5 Mc/s.

The main tuning dial has five scales, all direct-reading in output frequency. To facilitate tuning, a slow-motion worm-and-wheel drive is incorporated; this control is fitted with a dial marked linearly from 0 to 100 to assist the operator in sub-

dividing the frequency scales of the main tuning dial. In addition, there is a fine-tuning control. Fine tuning is achieved by varying the reactor-screen supply voltage. The frequency coverage on the highest-frequency band is approximately 24 kc/s and proportionately less on the lower bands.

A carrier on/off switch (S11) is included to enable the r.f. signal to be interrupted without affecting the output circuits of the generator. This switch interrupts the h.t. supply to the screens of the multiplier valves for the band in use.

For all the r.f. bands, the output is taken via two resistive 75-ohm ladder-network attenuators in cascade. The first attenuator has a range of 80 dB and is variable in 20-dB steps; the second has a range of 20 dB in 2-dB steps. The input to the cascade is adjustable by means of the SET CARRIER control (R44), and is monitored by the MODULATION meter M1. The meter scale has a SET R.F. mark, and, respectively above and below this mark,  $\pm$  and  $-1$ -dB marks to allow interpolation between the 2-dB steps of the attenuator. The output from the second attenuator is applied to a coaxial cable which is permanently attached to the instrument; the direct open-circuit output obtainable from this

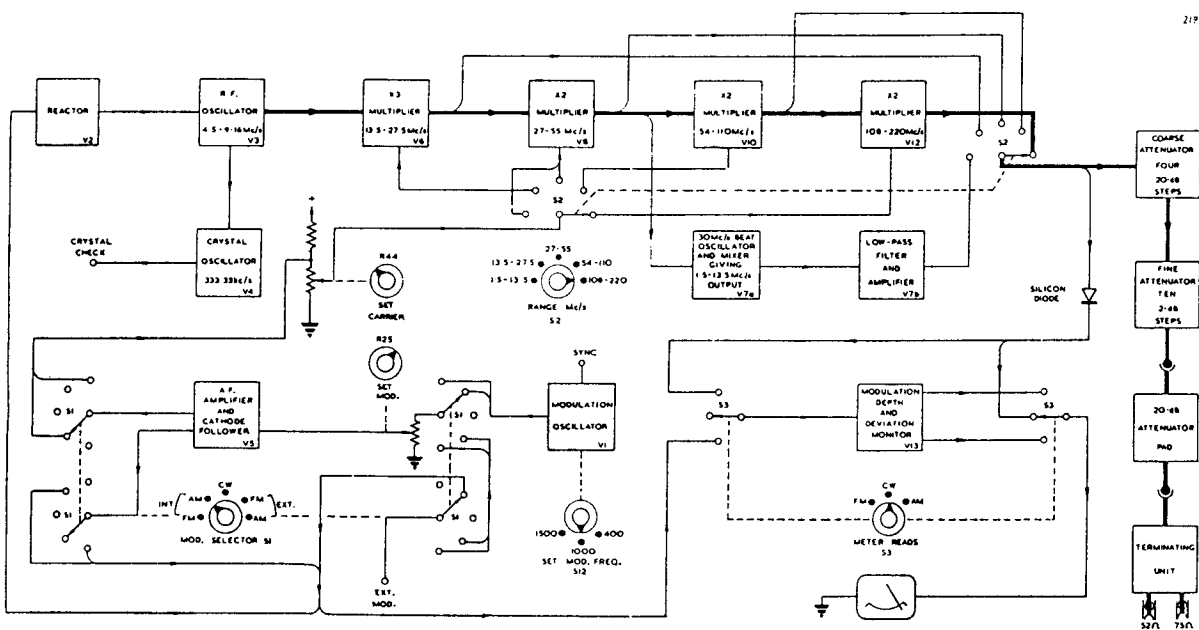

Fig. 3.1 Block Schematic Diagram.



cable is at a source impedance of 75 ohms and is variable between 2  $\mu$ V and 200 mV. By using the plug-on TERMINATING UNIT supplied, outputs 6 dB down on this range are obtainable at source impedances of both 75 and 52 ohms. With the optional ATTENUATOR PAD interposed between the output cable and the TERMINATING UNIT, outputs down to 0.1  $\mu$ V are obtainable.

To provide for incremental carrier shift and for frequency modulation, a reactor valve (V2) is included in the tuned circuit of the r.f. oscillator. Movement of the INC. FREQ. controls (R112 and the S10 potentiometer network) varies the d.c. bias applied to the grid of V2, causing a change in its mutual conductance and thus a change in the r.f. oscillator frequency. Both the d.c. shift voltage and the a.f. modulating signal are applied to the grid of the reactor valve via a tracking potentiometer (R7); this is ganged to the main tuning capacitor so that the deviation or carrier shift is kept constant as the Signal Generator is tuned over any one band.

The built-in crystal calibrator—the crystal unit of which has a fundamental frequency of 333.3 kc/s—is coupled to the variable-frequency r.f. oscillator and provides 14 checking points on each of the four upper frequency bands covered by the Signal Generator. The h.t. supply to the calibrator is automatically switched on by the insertion of a telephone plug into the CRYSTAL CHECK jack on the front panel; the heterodyne beats at the checking points may then be heard in the headphones or via the receiver under test. The cursor of the tuning dial is adjustable so that it may be set to correspond exactly with the nearest crystal checking point.

## 4.2 MODULATION SYSTEMS

Either internal or external a.f. modulation (f.m. or a.m.) may be applied; the SET MOD. FREQ. switch (S12) brings into circuit the appropriate tuning capacitor to give 400, 1,000, or 1,500 c/s modulation as required. For frequency modulation the a.f. signal passes through V5, switched as a cathode follower, and is applied to the reactor-valve input via the switched potentiometer network at S2ba and S2ca (part of the RANGE switch), and the tracking potentiometer R7. By this means, the ratio of the a.f. input voltage to f.m. deviation is maintained constant at all frequencies on each band, and is independent of the setting of either the RANGE switch or the TUNE controls.

The normal deviation ranges on all carrier bands are 0 to 5 kc/s and 0 to 15 kc/s. By means of the DEVIATION switch S5, the switched potentiometer system can be by-passed, thus enabling the deviation

to be increased proportionally with increase in frequency multiplication and permitting a maximum deviation on the highest-frequency band of  $15 \times 8 = 120$  kc/s. On the 1.5- to 13.5-Mc/s band, the maximum deviation obtainable is 30 kc/s.

Amplitude modulation to a depth continuously variable up to 50% is applied to the highest harmonic multiplier which is operating for the particular r.f. output band in use; this method helps to reduce the spurious frequency modulation often encountered when modulating an r.f. oscillator directly. The modulation is effected by supplying the anodes and screens of the multipliers from the tapped choke output of V5 which is switched to function as an a.f. amplifier.

Simultaneous amplitude and frequency modulation, for use, for example, when investigating the performances of limiter stages in f.m. receivers, is obtained by setting up the instrument for internal a.m. and then applying f.m. from an external source.

## 4.3 MONITORING ARRANGEMENTS

A two-stage amplifier-voltmeter provides monitoring facilities for a.m. depth and f.m. deviation. When S3 is switched to F.M., deviation is indicated on the panel meter by sampling the modulating voltages injected into the reactor valve V2: when switched to A.M., the input to the attenuators is sampled via the demodulating diode X2. When S3 is in the C.W. position, to which it is spring-biased, the voltmeter continuously monitors the r.f. input to the attenuators by means of its connection via the contacts S3b, and the silicon diode X2.

The design of the modulation monitoring circuits is such that with the Signal Generator set up for simultaneous a.m. and f.m., both percentage depth, and deviation, can be read independently.

## 4.4 POWER UNIT

The secondary winding of the mains transformer T4, in conjunction with the full-wave rectifier V11, provides for the positive d.c. h.t. requirements of the instrument; the h.t. supply to the reactor and r.f. oscillator valves is stabilized by means of a gas-filled stabilizer V9. The negative supply for the reactor-valve bias is drawn from a voltage-doubling circuit employing double-diode valve V15, and gas-filled stabilizer V14.

The primary of T4 is tapped to allow for operation from 100 to 150 volts, or 200 to 250 volts. Adequate filtering is introduced into the a.c. input circuit by means of the network C84, L24, C86 and C85, L25, C87.

# 5 MAINTENANCE

## 5.1 GENERAL

Section 4, TECHNICAL DESCRIPTION, of this handbook deals with the internal circuits of the Signal Generator and it is strongly recommended that the user should familiarize himself with the principles described there before commencing the adjustment or replacement of component parts of the instrument.

The Circuit Diagrams show all the electrical components contained in the instrument together with their values. The full description of these components is given in the Spares Ordering Schedule; the Schedule also lists certain selected mechanical components.

The physical location of the electrical components is shown on the Component Layout Illustrations.

## 5.2 REMOVAL OF CASE

To remove the Signal Generator case:—

- (1) Remove the screw securing the small plate in the left-hand side pocket; the mains lead is cleated to the case by means of this plate.

- (2) Extract the eight screws from around the edge of the front panel.
- (3) Pull the instrument clear of its case and disconnect the six-way interconnecting cable from the power unit chassis.
- (4) Detach the screw, from the inside of the case, which holds the cleating plate for the r.f. output cable to the right-hand side pocket.
- (5) After removing the seven screws from the underside of the case, lift out the power unit.

## 5.3 MAINS INPUT ARRANGEMENTS

The instrument is fitted with a mains transformer which has a double-wound primary; each primary section is tapped and the two sections can be connected in series-parallel for 100- to 150-volt operation or in series for 200- to 250-volt operation.

The 100- to 150-volt or the 200- to 250-volt range is selected by links on the coil of the transformer. Selection of intermediate voltages within either range is made by means of fly leads on the

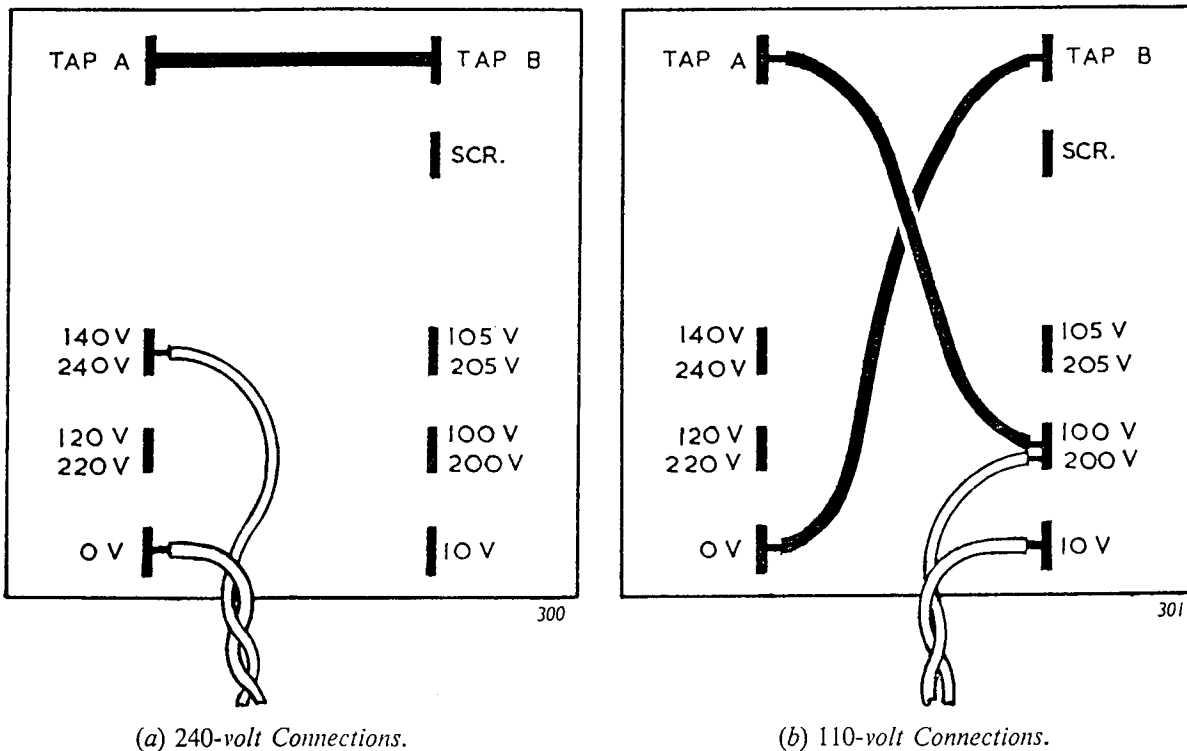

(a) 240-volt Connections.

(b) 110-volt Connections.

Fig. 5.1 Mains Transformer Tappings.

transformer tags. These tags are common to both ranges and are, therefore, annotated with two voltages; the applicable voltage depends on the position of the range links.

One fly lead must always be connected to either the '0' or the '10' tag; the other is connected to the tag whose voltage, added to 0 or 10 as appropriate, equals the mains supply voltage. Do not connect the fly leads to the tags marked TAP A or TAP B.

In order to examine the connections to the transformer and, if necessary, make adjustments, the instrument must be removed from its case in the manner described in Section 5.2. With the instrument out of its case, the transformer (T4 on Circuit Diagram, Fig. 8.2, and on Component Layout Illustration, Fig. 6.7) is immediately accessible.

For Supply Voltages within the range 200 to 250 volts, the tags on the transformer *must* be linked in the following manner:—

'TAP A' to 'TAP B'

For Supply Voltages within the range 100 to 150 volts, the tags on the mains transformer *must* be linked in the following manner:—

'0' to 'TAP B'

'100/200' to 'TAP A'

## 5.4 ACCESS TO ENCLOSED SUB-ASSEMBLIES

General tests or some peculiarity in the performance of the Signal Generator may suggest the desirability of inspecting the interior of one of the enclosed sub-assemblies which form part of the instrument. Any of these sub-assemblies can be dismantled by following the appropriate procedure as detailed in the sections below.

### 5.4.1 R.F. UNIT

To remove the screening cover from the r.f. unit:—

- (1) Remove the instrument from its case and lay it face downwards.
- (2) Extract the two screws which secure the screening cover of the r.f. unit.
- (3) Grip the sides of the screening cover and draw it off; the cover is held by earthing contact springs and will consequently offer some resistance to removal.

### 5.4.2 'MULTIPLY BY' ATTENUATOR

A view of the MULTIPLY BY (fine) attenuator with the screening cover removed is shown in Component Layout Illustration, Fig. 6.6. To dismantle the attenuator:—

- (1) Remove the attenuator screening cover after extracting the single securing screw.
- (2) Remove the front-panel control knob after slackening the two grub screws which secure it to its associated spindle.
- (3) Detach the main body of the attenuator from the front panel by extracting five screws; three of these screws are visible on removal of the control knob as in (2) above; the two remaining screws are located immediately above the 8-dB and 12-dB panel markings.

With the attenuator thus detached, it remains coupled to the body of the instrument by two coaxial leads; these leads are normally long enough to permit inspection and, if necessary, replacement of the attenuator resistors without completely disconnecting the attenuator.

Reassemble the attenuator in the reverse order to that detailed above.

### 5.4.3 'OUTPUT VOLTAGE' ATTENUATOR AND MONITOR DIODE

In addition to the actual attenuator components, the r.f. monitor diode, X2, and its associated filter components are mounted in the OUTPUT VOLTAGE attenuator casing. When dismantling the attenuator, the user should refer to Component Layout Illustration, Fig. 6.6. Access to the diode, X2, resistors R71 and R72, and capacitors C88, C89, and C90 can be obtained by removing the cover of the attenuator in the following manner:

- (1) Disconnect R70 from the small insulated spigot projecting through the cover of the attenuator.
- (2) Remove the central securing screw and lift the screening cover clear of the attenuator body.

To obtain access to the attenuator resistors, R73 to R82, detach the attenuator from the front panel of the Signal Generator in the following manner:—

- (3) Remove the control knob by slackening the two grub screws securing it to its spindle.
- (4) Extract the five fixing screws securing the attenuator to the front panel; three of these screws are immediately visible on removing the control knob as in (3) above; the two remaining screws are located immediately above and to the right of the coarse-attenuator panel markings.

With the attenuator detached as in (4) above, it remains coupled to the body of the instrument by two coaxial cables. These cables are, however, long enough to permit inspection and, if necessary, replacement of the attenuator-resistors without completely disconnecting the attenuator.

Reassemble the attenuator in the reverse order to that detailed above.

### 5.4.4 MAINS INPUT FILTER UNIT

To gain access to the components comprising the mains input filter:—

- (1) Remove the nut and screw which secure, at the open end, the two halves of the mains filter unit screening cover.
- (2) Separate the push-fit screening channel from the fixed half of the screening cover.

Reassemble the screening cover in the reverse order to that detailed above.

### 5.4.5 POWER UNIT

To remove the power unit from the instrument case:—

- (1) Remove, from the underside of the instrument case, the five screws which engage with nuts along the front and left-hand flanges of the power unit chassis.
- (2) Holding the power unit with one hand, remove the remaining two screws which engage with the tapped bushes on the right-hand flange of the power unit.

Replace the power unit in the reverse order to that detailed above.

## 5.5 WORKING VOLTAGES

The voltages given in this section for guidance when servicing the instrument were obtained from

TABLE 4

Valve No.	$V_a$	$V_{g2}$	$V_k$
V1	245	50	1.5
V2	150	150	4
V3	150	95	—
V4	27	27	—
V5	250	250	3.0*
V6	130	160	—
V7†	Pin 1 235	—	—
V7†	Pin 6 250	—	2.5
V8	105	155	—
V9	150	—	—
V10	150	150	—
V11‡	Pin 4 260	—	295
	Pin 6 260	—	—
V12	150	150	—
V13	Pin 1 260	—	Pin 3 130
V13	Pin 6 85	—	Pin 8 18

\*The cathode potential of V5 will increase to 40 volts when the MOD. SELECTOR switch is set to INT. MOD.—F.M.

†When checking the voltages on V7, set the RANGE Mc/s switch to 1.5–13.5.

‡All voltages shown are d.c. except for V11 anodes.

measurements made with a 20,000 ohms/volt meter on a representative Signal Generator Type TF 995A/5.

Primary winding of T4 (Supply Voltage) 240 volts a.c.

H.T. secondary winding and chassis 260–0–260 volts a.c.

Heater winding LTR 5 volts a.c.

Heater winding LT 6.3 volts a.c.

Pin 1 on plug PL1 and chassis 260 volts d.c.

Junction of R117/R118 and chassis —85 volts d.c.

Junction of L16/L17 and chassis 280 volts d.c.

Cathode of V11 and chassis 295 volts d.c.

Table 4 lists certain valve electrode voltages in the TF 995A/5. When checking the instrument against these voltages, the MOD. SELECTOR switch should be set to INT. MOD.—A.M., the RANGE switch (unless otherwise specified) should be set to 108–220 Mc/s, and the SET CARRIER and SET MOD. controls should be turned to their maximum and minimum settings respectively.

## 5.6 REPLACEMENT OF VALVES AND SEMICONDUCTORS

The types of valve used in the instrument, their base connections, and some guidance as to suitable alternatives if the types originally fitted are not readily available, are given in Table 5.

The valves and semiconductor diodes may normally be replaced without special selection. Valves V1, V5, V9, V11, and V13 to V15 are immediately accessible on removing the instrument from its case. To gain access to the 333.3-kc/s oscillator crystal, X1, and to the remaining valves, remove the R.F. Unit screening cover. The crystal diode, X2, forms part of the OUTPUT VOLTAGE attenuator assembly and can be removed by the procedure detailed in Section 5.4.3.

Replacement of valves or semiconductors may necessitate either the reselection of associated components or readjustment of associated preset controls; aspects of this reselection and readjustment are discussed in the following Section.

## 5.7 PRESET AND SPECIALLY SELECTED COMPONENTS

During the factory calibration of the instrument, certain of its performance characteristics are brought within fine limits by means of preset components. Following the replacement or ageing of certain fixed components, it may become necessary to repeat the calibration procedure by which the presets were adjusted.

The Description column of the Spares Ordering Schedule shows which of the components are of

TABLE 5

Any valve which becomes faulty should preferably be replaced by a valve of the type originally supplied in the instrument and designated in the following table. If this is not possible, the additional data given by the table may be used as a guide to suitable alternatives.

Valve	Type	Base	British Commercial Equivalent	British Services Equivalent	U.S. Equivalent
V1	6AK6 Power Pentode	 (B7G)		CV1762	6AK6
V2, V4, V6, V8, V10, V12	6AK5 H.F. Pentode	 (B7G)	EF95	CV850	6AK5
V3	EF86 Pentode	 (B9A)	2729	CV2901	6267
V5	6AU6 Pentode	 (B7G)	EF94	CV2524 CV4023	6AU6
V7, V13	12AT7 Double Triode	 (B9A)	ECC81	CV455	12AT7
V9	OA2 Voltage Stabilizer	 (B7G)	OA2 150C2 150C4 QS1207	CV1832 CV4020	OA2

TABLE 5 (continued)

Valve	Type	Base	British Commercial Equivalent	British Services Equivalent	U.S. Equivalent
V11	5Z4G Full-Wave Rectifier	 (IO)	R52 GZ30 52KU U50	CV1863	5Z4G
V14	5651 Voltage Stabilizer	 (B7G)	QS1209 QS83/3 85A2	CV2573 CV449	5651 OG3
V15	6AL5 Double Diode	 (B7G)	D77 6D2 D152 DD6 EB91	CV140	6AL5

the preset type; components which are individually selected are distinguished in that column by a single asterisk.

If, in servicing a TF 995A/5, it is necessary to replace any of these components, it will also be necessary, if the performance or accuracy of the instrument is not to be impaired, to repeat the factory calibration procedure by which the components were originally selected.

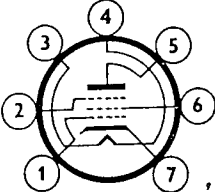
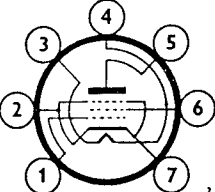
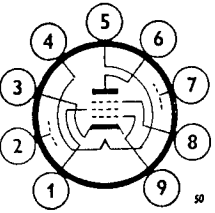
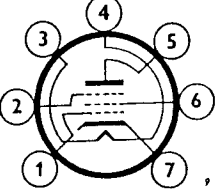
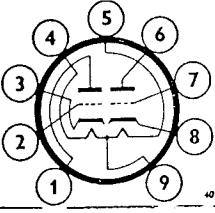
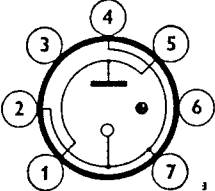
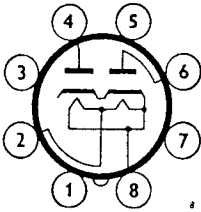
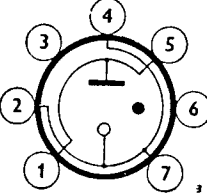
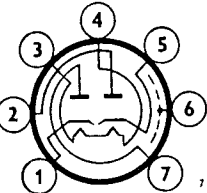
Section 5.8 gives a range of tests by which the main points of the performance of the instrument can be checked; this section also deals with the adjustment of preset components and with the choice of value for individually selected components.

It will be appreciated that it may sometimes be necessary to reselect a selected component even though that component itself has not been found faulty and replaced in initial servicing operations. To take an example—the internal modulation oscillator is tuned to 1,000 c/s by T1 and C6. In manufacture, C6 is selected to give an oscillator frequency of 1,000 c/s  $\pm$  5%. In servicing the instrument it might be found that T1 was faulty but that C6 was not. If T1 was replaced then it

TABLE 6

Component	Section Describing Adjustment or Selection	Component	Section Describing Adjustment or Selection
R19	5.8.10	C6	5.8.9
R39	5.8.17	C35	5.8.5
R70	5.8.8	C40	5.8.7
R119	5.8.13	C47	5.8.6
R127	5.8.12	C59	5.8.7
R128	5.8.12	C66	5.8.6
R129	5.8.12	C76	5.8.6
R130	5.8.16	C83	5.8.6
R131	5.8.11	C93	5.8.4
R132	5.8.13	C101	5.8.9
R133	5.8.13	C102	5.8.9
R134	5.8.11	L18	5.8.6
R136	5.8.12	L22	5.8.6
R138	5.8.12	L23	5.8.6
R140	5.8.12	T2	5.8.5
R163	5.8.13	T3	5.8.6

would be quite likely that with the original C6 the oscillator frequency would be outside the specified limits of  $\pm 5\%$  and that a new value of capacitance would have to be chosen.

It therefore follows that, in all servicing involving replacement of components, the user should consider carefully the possible effects on the performance of the stage or stages involved.

Table 6 on page 29 lists the circuit reference numbers of both types of component together with the numbers of the sections in which their adjustment or selection is described.

## 5.8 SCHEDULE OF TESTS

The following information, based on abstracts from the internal Factory Test Schedule, is included to enable the user to carry out a series of tests by which the main points of performance of the instrument can be checked; it also gives details concerning the adjustment to preset components and the choice of value for individually selected components.

### 5.8.1 APPARATUS REQUIRED

- (a) 750-volt Insulation Tester.
- (b) Avometer, Model 8.
- (c) Wave Analyser; Marconi Type TF 455 (Series).
- (d) Signal Generator, with standardized output; Marconi Types TF 801 (Series) or TF 995 (Series).
- (e) Valve Voltmeter; Marconi Type TF 1041B.
- (f) Audio-Frequency Oscillator; Marconi Types TF 195 (Series), TF 885 (Series), TF 894 (series), or TF 1101.
- (g) Cathode-Ray Oscilloscope; Marconi Type TF 1330 (Series).
- (h) Deviation Meter; Marconi Type TF 791 (Series).
- (i) Counter-type Frequency Meter; Marconi Type TF 1417/2.
- (j) Crystal Calibrator; Marconi Type TF 1374
- (k) Standardized Wavemeter; Marconi Type TF 975.
- (l) A.M. Communications Receiver, covering the range 1.5 to 220 Mc/s.

**Note:** For the F.M. on C.W. check (Section 5.8.18), where deviations of less than 50 c/s have to be measured, it is essential that the deviation meter should be modified to operate from battery supplies, or incorporate facilities allowing its local oscillator to be brought under crystal control.

### 5.8.2 INSULATION

(Apparatus required: Item a)

Test the insulation between each pin of the supply plug and chassis with SKT1 engaged with PL1. This reading should not normally be less than 40M $\Omega$ .

### 5.8.3 HUM LEVEL

(Apparatus required: Item c)

Measure the 100 c/s hum level at HT1 using a Wave Analyser isolated from the TF 995A/5 by a 4- $\mu$ F capacitor. The hum level should not normally exceed 10mV.

### 5.8.4 CRYSTAL OSCILLATOR

(Apparatus required: Items e and i)

Plug headphones into the CRYSTAL CHECK socket and, by means of a loop of wire slipped over V4, take an output to the Counter-type Frequency Meter. Check the crystal frequency, it should usually lie between 333.266 c/s and 333.400 c/s. C93 may be padded with a value not exceeding 10  $\mu$ F to achieve this.

Using the Valve Voltmeter, measure the r.f. voltage across R27; it should normally lie between 8 and 15 volts.

### 5.8.5 BASIC OSCILLATOR

(Apparatus required: Items e and k)

Set the MOD. SELECTOR switch to C.W. and the RANGE switch to Band 2, 13.5 to 27 Mc/s. Coarse tune to 13.5 Mc/s (on Band 2) and adjust the dust core of T2 until the circuit oscillates at 4.5 Mc/s as indicated by the Wavemeter. Set the main tuning dial to 27 Mc/s and tune the trimmer C35 until the circuit oscillates at 9 Mc/s. Repeat these two adjustments for the most accurate frequency calibration; a calibration accurate to within  $\pm 1\%$  is usually to be expected if this procedure is carried out. Check the tuning adjustments against the crystal by means of headphones plugged into the CRYSTAL CHECK jack socket.

Measure the r.f. voltages at the anode and grid of V3; these should be of the following order:—

	4.5 Mc/s	9.0 Mc/s
Grid	2.65 volts	9 volts
Anode	21 volts	41 volts

### 5.8.6 FREQUENCY MULTIPLIERS

(Apparatus required: Item j)

#### (I) 13.5- to 27-Mc/s band

Set the MOD. SELECTOR switch to C.W., the RANGE switch to 13.5–27 Mc/s, and the SET CARRIER control fully clockwise.

Set the main dial to 13.5 Mc/s, and adjust the core of T3 for maximum deflection on the panel meter. The SET CARRIER control, R44, should be readjusted if necessary.

Set the main dial to 27 Mc/s, and adjust C47 for maximum deflection on the meter.

Repeat these two adjustments several times until no further change is required, finishing with C47. Check that the output as indicated on the front-panel meter is sensibly constant over the whole band.

### (2) 27- to 54-Mc/s band

Set the RANGE switch to 27–54 Mc/s, and the SET CARRIER control fully clockwise.

Set the main dial to 27 Mc/s, and adjust the spacing of the turns of L18 for maximum deflection on the panel meter. The SET CARRIER control should be readjusted if necessary.

Set the main dial to 54 Mc/s, and adjust C66 for maximum deflection on the meter.

Repeat these two adjustments several times until no further change is required, finishing with C66. Check that the output as indicated on the front-panel meter is sensibly constant over the whole band.

### (3) 54- to 108-Mc/s band

Set the RANGE switch to 54–108 Mc/s and, using a similar procedure to (2) above, adjust L22 and then C76 at 54 and 108 Mc/s respectively.

### (4) 108- to 220-Mc/s band

Set the RANGE switch to 108–220 Mc/s and, using a similar procedure to (2) above, adjust L23 and then C83 at 108 and 220 Mc/s respectively.

With the R.F. Box cover in position, check the frequency accuracy on all the above bands with the Crystal Calibrator. The frequency accuracy of the TF 995A/5 should be about  $\pm 1\%$ .

## 5.8.7 1.5- TO 13.5-Mc/s BAND

*(Apparatus required: Item l)*

*This test must be made with the r.f. unit cover in position.*

By means of a suitable jack plug, connect a pair of headphones to the CRYSTAL CHECK socket.

Set the RANGE switch to 1.5–13.5, and adjust the TUNE control to bring the 30 Mc/s main dial marking (on the 27–54 Mc/s arc) to the cursor; then, using the Crystal Calibrator, tune for zero beat.

With the SET CARRIER control in its fully clockwise position, adjust C40 and C59 alternately to give minimum deflection on the panel meter. These capacitors are accessible through two holes, slightly larger than the ventilation holes, in the top of the r.f. unit cover.

Connect the output of the Signal Generator to a receiver, and tune the receiver to some convenient accurately-known frequency between 1.5 and 13.5 Mc/s.

Set the main dial of the TF 995A/5 to this frequency, and adjust C40 for maximum receiver response.

In the absence of any other frequency standard, the receiver tuning may be standardized at frequencies between 4.5 and 9 Mc/s by loosely coupling its input to the basic oscillator of the TF 995A/5. This oscillator should first be standardized against the internal crystal calibrator, the basic-oscillator frequency being given by dividing by three the indication on the 13.5–27 scale.

## 5.8.8 R.F. OUTPUT VOLTAGE ACCURACY

*(Apparatus required: Item e)*

*This test should be carried out with the instrument in its case.*

Set the MOD. SELECTOR switch to C.W., and tune to 25 Mc/s. Set the OUTPUT VOLTAGE and MULTIPLY BY attenuators to give a joint indication of 100 dB above 1  $\mu$ V (i.e. both fully clockwise). Connect the Signal Generator to the TERMINATING UNIT, and connect the 75-ohm outlet of the TERMINATING UNIT to the voltmeter. Adjust the SET CARRIER control to give an output level of 100 mV as indicated on the Voltmeter; if the front-panel meter pointer is not exactly at the SET R.F. mark, reselect R70.

Check that the output from the 52-ohm socket is also 100 mV. The maximum obtainable output over all bands should also be checked, it will usually be found to be greater than 1 dB above the SET R.F. mark.

## 5.8.9 MODULATION OSCILLATOR

*(Apparatus required: Items e, f and g)*

With the MOD. SELECTOR switch set to INT. MOD. —A.M. and the SET MOD. FREQ. control at 1,000, monitor the a.f. signal between the SYNC and E terminals. With the Cathode-Ray Oscilloscope, and using the Audio Oscillator as a standard frequency source, verify, by the method of Lissajous figures, that the oscillator frequency lies within the limits 1,000 c/s  $\pm 5\%$ . If it does not, reselect C6.

Check the modulation-oscillator frequency at 400 c/s and 1,500 c/s by the above method. If necessary, the following capacitors may have to be reselected to obtain the required frequencies: for 400 c/s modulation, C101; for 1,500 c/s modulation, C102.



**5.8.10 F.M. DISTORTION***(Apparatus required: Items c and h)*

Set the DEVIATION—NORMAL/HIGH switch to NORMAL, the DEVIATION RANGE switch to 15 kc/s, the MOD SELECTOR switch to INT MOD—F.M., and the RANGE switch to 13.5–27; then adjust the SET CARRIER control to give a convenient deflection on the TF 995A/5 panel meter.

Connect the output cable directly to a carrier deviation meter, tune both instruments to 20 Mc/s, and adjust the TF 995A/5 attenuators for maximum output.

Adjust the SET MOD control to produce 15 kc/s deviation, and check that the positive and negative deviations as indicated on the deviation meter are equal. If they are unequal, select a value for R19 to produce equal positive and negative deviations.

Apply the demodulated f.m. signal from the deviation meter to a wave analyser, and measure the total distortion at 13.5 Mc/s. The total f.m. distortion should not exceed 2%.

**5.8.11 F.M. TRACKING AND RANGE 2 SENSITIVITY***(Apparatus required: Items f and h)*

Set the MOD SELECTOR switch to EXT MOD—F.M., the DEVIATION RANGE switch to 15 kc/s, and adjust the SET CARRIER control to bring the meter pointer to SET R.F. Set the OUTPUT VOLTAGE and MULTIPLY BY attenuators to 100 dB, connect the output cable directly to a deviation meter and tune both instruments to 13.5 Mc/s (range 2).

Connect the audio oscillator to the EXT MOD terminals and feed in a 20 V, 1 kc/s signal. Turn the SET MOD control fully clockwise and check that the deviation indicated on the external deviation meter is at least 18 kc/s adjusting R131, if necessary, to obtain this figure.

Turn the MOD SELECTOR switch to INT MOD F.M. and adjust the SET MOD control until the external deviation meter indicates a deviation of 15 kc/s.

Tune both the TF 995A/5 and the deviation meter to 27 Mc/s (range 2). Note the deviation and, if necessary, adjust R134, so that the deviation is maintained at 15 kc/s.

**5.8.12 DEVIATION MONITOR***(Apparatus required: Item h)*

Put the MOD SELECTOR switch to INT MOD—F.M. the DEVIATION—NORMAL/HIGH switch to NORMAL.

Turn the SET CARRIER control to give a convenient deflection on the TF 995A/5 output meter. Connect the output cable directly to a carrier deviation meter; and set the TF 995A/5 attenuator controls to give maximum output and tune both instruments to 20 Mc/s.

With the DEVIATION RANGE switch at 15 kc/s and the METER READS switch at C.W. adjust the SET MOD control until 15 kc/s deviation is indicated on the external deviation meter. Press the METER READS switch to F.M. and adjust R129 so that the deviation meter (M1) reads 15 kc/s.

Return the METER READS switch to C.W. and turn the DEVIATION RANGE switch to 5 kc/s. Adjust R127 to obtain 5 kc/s deviation shown by the external deviation meter.

Press the METER READS switch to F.M. and adjust R128 so that the deviation meter (M1) reads 5 kc/s.

Turn the RANGE switch to 27–54 Mc/s and tune the external deviation meter to the same frequency. Adjust the SET MOD control to give an indicated deviation of 15 kc/s, with the DEVIATION RANGE switch at 15 kc/s. Adjust R140 so that a true deviation of 15 kc/s is obtained, as shown by the external deviation meter. Repeat this procedure on the 54–108 Mc/s and 108–220 Mc/s bands setting R138 and R136 respectively for true deviation of 15 kc/s.

If a Deviation Meter is not available, the following method may be used to determine the frequency deviation. This method—the disappearing carrier method—depends upon the fact that the carrier, as opposed, of course, to the sidebands, disappears when the modulation index  $\mu$  (the ratio of the frequency deviation  $\delta F$  to the modulation frequency  $f$ ) has values of 2.4, 5.52, 8.65, 11.79, etc. Therefore, if the modulation frequency,  $f$ , is known, since deviation,  $\delta F$ , is equal to  $\mu f$ , deviation can be simply calculated when  $\mu$  is known—i.e. at a carrier disappearance point. For example, if the applied modulation has a frequency of 10 kc/s and the deviation is progressively increased until the carrier disappears, the deviation must be  $2.4 \times 10 = 24$  kc/s, and again  $5.52 \times 10 = 55.2$  kc/s.

To determine these points, apply the output of the TF 995A/5 to a narrow-band (communication) a.m. receiver and tune the latter to the unmodulated output frequency of the TF 995A/5. Set the beat oscillator of the receiver to give an audio note; then frequency modulate the Signal Generator at a fairly high frequency outside the passband of the a.m. receiver—such as 10 kc/s—starting from zero deviation and increasing the deviation until the beat with the carrier disappears. At this point the actual deviation can be calculated as described above.

**5.8.13 THE INCREMENTAL FREQUENCY CONTROLS***(Apparatus required: Items i and j)*

Check that the FINE INC. FREQ. dial is positioned so that the 0 coincides with the cursor when the

potentiometer wiper is at its mid-travel position. Switch to Band 2 and apply the Generator output to the Crystal Calibrator; tune, by means of the main tuning control, for a zero beat on the Calibrator. If necessary, reselect R119 so that there is no change in zero beat when C42 is short circuited; i.e. with the fine incremental frequency dial at zero, there should be zero volts on the wiper of R112.

At some convenient frequency, say 150 Mc/s, feed the output of the TF 995A/5 to the Electronic Counter and set the fine incremental frequency control to zero. Set the steps of the coarse incremental frequency control to be 20 kc/s and 40 kc/s by adjusting R133 on band 5. Repeat the procedure on Band 4, this time adjusting R132. Next, adjust R163 so that the fine incremental frequency control has a cover of 15 kc/s on bands 5 and 4 and check that its calibrations are at 1-kc/s intervals. It may be necessary to adjust R114 to obtain sufficient incremental shift.

#### 5.8.14 HIGH DEVIATION

(Apparatus required: Item h)

Connect the output of the TF 995A/5 to a Deviation Meter and check that, when the TF 995A/5 is set for 9 kc/s deviation with the DEVIATION—NORMAL/HIGH switch set to NORMAL, the indication on the meter rises to approximately the following values when the DEVIATION—NORMAL/HIGH switch is set to HIGH.

BAND	RANGE Mc/s	HIGH Deviation for 9 kc/s
(1)	1.5–13.5	18 kc/s
(2)	13.5–27.5	9 kc/s
(3)	27–55	18 kc/s
(4)	54–110	36 kc/s
(5)	108–220	72 kc/s

#### 5.8.15 EXTERNAL F.M.

(Apparatus required: Items f and h)

Tune the Generator and Deviation Meter to a convenient frequency (say 20 Mc/s). Set the MOD. SELECTOR switch (S1) to EXT. MOD.—F.M. and apply a 1 kc/s signal from the Audio Oscillator to the EXT. MOD. and E terminals of the TF 995A/5.

Bring the a.f. input voltage to a convenient point on the dB scale of the a.f. oscillator output monitor and adjust the SET MOD control to give a true deviation of 10 kc/s as indicated on the external deviation monitor. Press the METER READS switch to F.M. and note the meter reading.

Vary the audio input frequency from 50 c/s to 15 kc/s keeping the TF 995A/5 meter (M1) reading, obtained with the METER READS switch at F.M., constant at the previously noted value. This constant

reading must be achieved by adjustment of the input voltage and not by variation of the SET MOD control. Monitor the corresponding deviation indicated by the external deviation meter. Check that the total variation of the input level and the true deviation does not exceed  $\pm 1$  dB.

#### 5.8.16 INTERNAL A.M.

(Apparatus required: Items g and l)

Apply the output of the TF 995A/5 to a frequency changer circuit which is followed by an i.f. amplifier and Cathode Ray Oscilloscope; the i.f. amplifier should have a centre frequency which will allow its output to be viewed directly on the c.r.o. Set the MOD. SELECTOR switch to INT. MOD.—A.M. and adjust the SET MOD. control for 50% modulation as measured on the c.r.o. screen, using the formula:—

$$M(\%) = \frac{D_{\max} - D_{\min}}{D_{\max} + D_{\min}} \times 100\%$$

where  $D_{\max}$  = the peak-to-peak dimensions of the c.r.o. display.

$D_{\min}$  = the trough-to-trough dimensions of the c.r.o. display.

Hold the METER READS switch to A.M. and check that the meter reading is correct. If not, adjust R130.

#### 5.8.17 EXTERNAL A.M.

(Apparatus required: Items f, g, and l)

Set the MOD. SELECTOR switch (S1) to EXT. MOD.—A.M. and feed the output of the Audio Oscillator to the EXT. MOD. terminals of the TF 995A/5. Tune the Signal Generator to 20 Mc/s and view the modulation envelope as previously described.

Bring the a.f. input voltage to a convenient point on the dB scale of the a.f. oscillator monitor and adjust the SET MOD control to give a true modulation depth of 30%. Press the METER READS switch to AM and note the meter reading.

Vary the audio input frequency from 100 c/s to 10 kc/s keeping the TF 995A/5 meter (M1) reading, obtained with the METER READS switch at AM, constant at the previously noted value. This constant reading must be achieved by adjustment of the input voltage, and not by variation of the SET MOD control. Measure the corresponding modulation depth with the oscilloscope; check that the variation of true modulation depth does not exceed 0.5 dB and that the variation of input voltage does not exceed 1 dB. If the variations exceed these limits select a new value for R39.

**5.8.18 SPURIOUS F.M. ON C.W.**

*(Apparatus required: Items c and h)*

To measure small amounts of spurious f.m., connect the Wave Analyser, Type TF 455 (Series), to the l.f. output of the Deviation Meter, using it as a tuned l.f. level indicator.

Note its level indication for a measured 2.5 kc/s deviation; then, since the l.f. output of the monitor varies linearly with deviation, small amounts of

f.m. may be calculated directly by noting the l.f. output level; for example, 25 c/s f.m. will give a level 40 dB below that for 2.5 kc/s.

Switch to C.W. on the MOD. SELECTOR switch and, with the output level adjusted to the SET R.F. mark, check, at carrier frequencies of 90 and 216 Mc/s, that there is negligible frequency modulation of the signal; the spurious deviation is not likely to exceed 25 c/s.

For Service Manuals Contact  
MAURITRON TECHNICAL SERVICES  
8 Cherry Tree Rd, Chinnor  
Oxon OX9 4QY  
Tel:- 01844-351694 Fax:- 01844-352554  
Email:- enquiries@mauritron.co.uk

# 7 SPARES ORDERING SCHEDULE

## for F.M./A.M. SIGNAL GENERATOR TYPE TF 995A/5

When ordering replacement parts, always quote the TYPE NUMBER and SERIAL NUMBER of the instrument concerned.

To specify the individual parts required, state for each part the QUANTITY required and the appropriate SOS ITEM NUMBER.

For example, to order replacements for the 270-k $\Omega$  resistor, R4, and the 5- $\mu$ F capacitor, C73, quote as follows:—

*Spares for TF995A/5, Serial number 000000*

1 off, SOS Item 4

1 off, SOS Item 210

It is important that the distinguishing code 'SOS' preceding each item number should not be omitted.

SOS Item No.	Circuit Ref.	Description	Works Ref.
<b>RESISTORS</b>			
1	R1	Composition, 470 k $\Omega$ $\pm$ 20%, $\frac{1}{4}$ W.	4-TM4800/2
2	R2	Composition, 1.5 k $\Omega$ *, $\frac{1}{2}$ W.	58-TM4826/5
3	R3	Composition, 220 k $\Omega$ $\pm$ 10%, $\frac{1}{2}$ W.	18-TM4800/2
4	R4	Composition, 270 k $\Omega$ $\pm$ 10%, $\frac{1}{4}$ W.	5-TM4800/2
5a	R5	Metal oxide, 47 k $\Omega$ $\pm$ 7% TE, $\frac{3}{8}$ W.	12-TM4706/1
6	R6	Composition, 2.2 k $\Omega$ *, $\frac{1}{2}$ W.	59-TM4826/5
7	R7	Wire-wound, Variable 50 k $\Omega$ $\pm$ 10%, 3W.	18-TM4831/2
8a	R8	Metal oxide, 4.7 k $\Omega$ * $\pm$ 7% TE, $\frac{3}{8}$ W.	146-TM4826/5
9	R9	Composition, 5.1 k $\Omega$ *, $\frac{1}{2}$ W.	7-TM4706
10	R10	Composition, 10 k $\Omega$ $\pm$ 10%, $\frac{1}{2}$ W.	6-TM4800/2
11a	R11	Metal oxide, 18 k $\Omega$ $\pm$ 7% TE, $\frac{3}{8}$ W.	4-TM4706/1
12	R12	Composition, 4.7 k $\Omega$ *, $\frac{1}{2}$ W.	8-TM4706
13a	R13	Metal oxide, 12 k $\Omega$ $\pm$ 7% TE, $\frac{3}{8}$ W.	10-TM4706/1
14	R14	Composition, 8.2 k $\Omega$ *, $\frac{1}{2}$ W.	6-TM4706
15	R15	Composition, 4.7 k $\Omega$ $\pm$ 10%, $\frac{1}{4}$ W.	8-TM4800/2
16	R16	Wire-wound, 4.7 k $\Omega$ $\pm$ 5%, 7W.	113-TM4826/5
17	R18	Composition, 220 k $\Omega$ $\pm$ 10%, $\frac{1}{4}$ W.	7-TM4800/2
18a	R19	Composition, 1.2 k $\Omega$ *, $\frac{1}{4}$ W.	53-TM4826/5
19	R20	Composition, 10 k $\Omega$ $\pm$ 5%, $\frac{1}{4}$ W.	62-TM4826/5
20	R21	Composition, 68 k $\Omega$ $\pm$ 10%, $\frac{1}{4}$ W.	66-TF995A/5

\* Nominal value; actual value determined during calibration.

SOS Item No.	Circuit Ref.	Description	Works Ref.
21	R22	Composition, $68 \text{ k}\Omega \pm 10\%$ , $\frac{1}{4}\text{W}$ .	66-TF995A/5
22	R23	Composition, $56 \text{ k}\Omega \pm 10\%$ , $\frac{1}{4}\text{W}$ .	63-TM4826/5
23a	R24	Composition, $22 \text{ k}\Omega \pm 10\%$ , $\frac{1}{2}\text{W}/55^\circ\text{C}$ .	6-TM4943DG
24	R25	Composition, Variable $20 \text{ k}\Omega \pm 20\%$ , $\frac{1}{4}\text{W}$ .	74-TF995A/5
25	R26	Composition, $15 \text{ k}\Omega \pm 10\%$ , $\frac{1}{4}\text{W}$ .	64-TM4826/5
26	R27	Composition, $2.7 \text{ M}\Omega \pm 10\%$ , $\frac{1}{4}\text{W}$ .	52-TM4826/5
27	R28	Composition, $220 \text{ k}\Omega \pm 10\%$ , $\frac{1}{4}\text{W}$ .	10-TM4800/2
28	R29	Composition, $6.8 \text{ k}\Omega \pm 10\%$ , $\frac{1}{4}\text{W}$ .	65-TM4826/5
29	R30	Composition, $6.8 \text{ k}\Omega \pm 10\%$ , $\frac{1}{4}\text{W}$ . (Part of Item 266)	9-TM3900/52
30	R31	Composition, $270 \text{ k}\Omega \pm 10\%$ , $\frac{1}{4}\text{W}$ .	51-TM4826/5
31	R32	Composition, $150 \Omega \pm 10\%$ , $1\text{W}$ .	108-TM4826/5
32	R33	Composition, $2.2 \text{ k}\Omega \pm 10\%$ , $\frac{1}{4}\text{W}$ .	66-TM4826/5
33	R34	Composition, $390 \Omega \pm 5\%$ , $\frac{1}{2}\text{W}$ .	11-TM4800/2
34	R35	Wire-wound, $15 \text{ k}\Omega \pm 5\%$ , $7\text{W}$ .	112-TM4826/5
35	R36	Wire-wound, $7.5 \text{ k}\Omega \pm 5\%$ , $7\text{W}$ .	111-TM4826/5
36	R37	Wire-wound, $5 \text{ k}\Omega \pm 5\%$ , $7\text{W}$ .	110-TM4826/2
37	R38	Composition, $10 \Omega \pm 10\%$ , $\frac{1}{2}\text{W}$ .	67-TF995A/5
38	R39	Wire-wound, $47 \text{ k}\Omega^*$ , $10\text{W}$ .	110-TF995A/5
39	R40	Composition, $15 \text{ k}\Omega \pm 10\%$ , $\frac{1}{4}\text{W}$ .	64-TM4826/5
40	R41	Composition, $6.8 \text{ k}\Omega \pm 10\%$ , $\frac{1}{4}\text{W}$ .	65-TM4826/5
41	R42	Composition, $2.2 \text{ k}\Omega \pm 10\%$ , $\frac{1}{4}\text{W}$ .	66-TM4826/5
42	R43	Composition, $10 \text{ k}\Omega \pm 10\%$ , $1\text{W}$ .	61-TF995A/5
43	R44	Wire-wound, Variable $200 \text{ k}\Omega + 200 \text{ k}\Omega$ .	75-TF995A/5
44a	R45	Composition, $100 \text{ k}\Omega \pm 10\%$ , $\frac{1}{4}\text{W}$ .	24342-135
45	R46	Composition, $6.8 \text{ k}\Omega \pm 10\%$ , $\frac{1}{2}\text{W}$ .	109-TM4826/5
46	R48	Composition, $2.2 \text{ k}\Omega \pm 10\%$ , $\frac{1}{4}\text{W}$ .	66-TM4826/5
47	R49	Wire-wound, $4 \text{ k}\Omega \pm 5\%$ , $7\text{W}$ .	72-TF995A/5
48	R50	Composition, $100 \text{ k}\Omega^*$ , $\frac{1}{2}\text{W}$ .	22-TM4800/5
49	R51	Composition, $4.7 \text{ k}\Omega \pm 10\%$ , $\frac{1}{4}\text{W}$ .	55-TM4826/5
50	R53	Composition, $270 \Omega \pm 10\%$ , $\frac{1}{4}\text{W}$ .	54-TM4826/5
51	R54	Composition, $6.8 \text{ k}\Omega \pm 10\%$ , $\frac{1}{4}\text{W}$ .	65-TM4826/5
52	R55	Composition, $68 \text{ k}\Omega \pm 10\%$ , $\frac{1}{4}\text{W}$ .	115-TM4826/5
53	R56	Composition, $47 \text{ k}\Omega \pm 20\%$ , $\frac{1}{2}\text{W}$ ; includes L21.	TB23173/9
54	R57	Composition, $2.2 \text{ k}\Omega \pm 10\%$ , $\frac{1}{4}\text{W}$ .	66-TM4826/5
55	R58	Composition, $100 \text{ k}\Omega \pm 10\%$ , $\frac{1}{4}\text{W}$ .	68-TM4826/5

\* Nominal value; actual value determined during calibration.

<i>SOS Item No.</i>	<i>Circuit Ref.</i>	<i>Description</i>	<i>Works Ref.</i>
56	R59	Composition, $6.8 \text{ k}\Omega \pm 10\%$ , $\frac{1}{4}\text{W}$ .	65-TM4826/5
57	R60	Composition, $100 \text{ k}\Omega \pm 10\%$ , $\frac{1}{4}\text{W}$ .	50-TM4826/5
58	R61	Composition, $2.2 \text{ k}\Omega \pm 10\%$ , $\frac{1}{4}\text{W}$ .	66-TM4826/5
59	R62	Composition, $33 \text{ k}\Omega \pm 20\%$ , $\frac{1}{2}\text{W}$ .; includes L19.	TB23173/10
60a	R63	Composition, $22 \text{ k}\Omega \pm 10\%$ , $\frac{1}{2}\text{W}/55^\circ\text{C}$ .	6-TM4943DG
61a	R64	Composition, $82 \text{ k}\Omega \pm 10\%$ , $\frac{1}{2}\text{W}/55^\circ\text{C}$ .	7-TM4943DG
62a	R65	Composition, $15 \text{ k}\Omega \pm 10\%$ , $\frac{1}{2}\text{W}/55^\circ\text{C}$ .	8-TM4943DG
63	R66	Composition, $33 \text{ k}\Omega \pm 10\%$ , $\frac{1}{4}\text{W}$ .	64-TF995A/5
64	R67	Composition, $470\Omega \pm 10\%$ , $\frac{1}{4}\text{W}$ .	63-TF995A/5
65	R68	Composition, $4.7 \text{ k}\Omega \pm 10\%$ , $\frac{1}{4}\text{W}$ .	62-TF995A/5
66	R69	Composition, $1 \text{ M}\Omega \pm 10\%$ , $\frac{1}{4}\text{W}$ .	59-TF995A/5
67	R70	Composition, $2.7 \text{ k}\Omega^*$ , $\frac{1}{4}\text{W}$ .	71-TF995A/5
68	R71	Composition, $1 \text{ k}\Omega \pm 10\%$ , $\frac{1}{4}\text{W}$ .	39-TM4297A
69	R72	Composition, $1 \text{ k}\Omega \pm 10\%$ , $\frac{1}{4}\text{W}$ .	39-TM4297A
70	R73	Carbon, High Stability, $82.5 \text{ k}\Omega \pm 1\%$ , $\frac{1}{8}\text{W}$ .	36-TM4297A
71	R74	Carbon, High Stability, $742\Omega \pm 1\%$ , $\frac{1}{8}\text{W}$ .	35-TM4297A
72	R75	Carbon, High Stability, $742\Omega \pm 1\%$ , $\frac{1}{8}\text{W}$ .	35-TM4297A
73	R76	Carbon, High Stability, $742\Omega \pm 1\%$ , $\frac{1}{8}\text{W}$ .	35-TM4297A
74	R77	Carbon, High Stability, $742\Omega \pm 1\%$ , $\frac{1}{8}\text{W}$ .	35-TM4297A
75	R78	Carbon, High Stability, $220\Omega \pm 1\%$ , $\frac{1}{8}\text{W}$ .	38-TM4297A
76	R79	Carbon, High Stability, $91.6\Omega \pm 1\%$ , $\frac{1}{8}\text{W}$ .	37-TM4297A
77	R80	Carbon, High Stability, $91.6\Omega \pm 1\%$ , $\frac{1}{8}\text{W}$ .	37-TM4297A
78	R81	Carbon, High Stability, $91.6\Omega \pm 1\%$ , $\frac{1}{8}\text{W}$ .	37-TM4297A
79	R82	Carbon, High Stability, $82.5\Omega \pm 1\%$ , $\frac{1}{8}\text{W}$ .	36-TM4297A
80	R83	Carbon, High Stability, $17.9\Omega \pm 1\%$ , $\frac{1}{8}\text{W}$ .	24-TM4298/2
81	R84	Carbon, High Stability, $17.9\Omega \pm 1\%$ , $\frac{1}{8}\text{W}$ .	24-TM4298/2
82	R85	Carbon, High Stability, $17.9\Omega \pm 1\%$ , $\frac{1}{8}\text{W}$ .	24-TM4298/2
83	R86	Carbon, High Stability, $17.9\Omega \pm 1\%$ , $\frac{1}{8}\text{W}$ .	24-TM4298/2
84	R87	Carbon, High Stability, $17.9\Omega \pm 1\%$ , $\frac{1}{8}\text{W}$ .	24-TM4298/2
85	R88	Carbon, High Stability, $17.9\Omega \pm 1\%$ , $\frac{1}{8}\text{W}$ .	24-TM4298/2
86	R89	Carbon, High Stability, $17.9\Omega \pm 1\%$ , $\frac{1}{8}\text{W}$ .	24-TM4298/2
87	R90	Carbon, High Stability, $17.9\Omega \pm 1\%$ , $\frac{1}{8}\text{W}$ .	24-TM4298/2
88	R91	Carbon, High Stability, $17.9\Omega \pm 1\%$ , $\frac{1}{8}\text{W}$ .	24-TM4298/2
89	R92	Carbon, High Stability, $17.9\Omega \pm 1\%$ , $\frac{1}{8}\text{W}$ .	24-TM4298/2
90	R93	Carbon, High Stability, $61.2\Omega \pm 1\%$ , $\frac{1}{8}\text{W}$ .	28-TM4298/2

\* Nominal value; actual value determined during calibration.

SOS Item No.	Circuit Ref.	Description	Works Ref.
91	R94	Carbon, High Stability, $332\Omega \pm 1\%$ , $\frac{1}{8}W$ .	26-TM4298/2
92	R95	Carbon, High Stability, $167\Omega \pm 1\%$ , $\frac{1}{8}W$ .	27-TM4298/2
93	R96	Carbon, High Stability, $167\Omega \pm 1\%$ , $\frac{1}{8}W$ .	27-TM4298/2
94	R97	Carbon, High Stability, $167\Omega \pm 1\%$ , $\frac{1}{8}W$ .	27-TM4298/2
95	R98	Carbon, High Stability, $167\Omega \pm 1\%$ , $\frac{1}{8}W$ .	27-TM4298/2
96	R99	Carbon, High Stability, $37.5\Omega \pm 1\%$ , $\frac{1}{8}W$ .	25-TM4298/2
97	R100	Carbon, High Stability, $90\Omega \pm 2\%$ , $\frac{1}{8}W$ .	16-TM5552
98	R101	Carbon, High Stability, $90\Omega \pm 2\%$ , $\frac{1}{8}W$ .	16-TM5552
99	R102	Carbon, High Stability, $360\Omega \pm 1\%$ , $\frac{1}{8}W$ .	17-TM5552
100	R103	Carbon, High Stability, $37.5\Omega \pm 5\%$ , $\frac{1}{8}W$ .	10-TM5551
101	R104	Carbon, High Stability, $75\Omega \pm 5\%$ , $\frac{1}{8}W$ .	11-TM5551
102	R105	Carbon, High Stability, $14.5\Omega \pm 5\%$ , $\frac{1}{8}W$ .	12-TM5551
103	R106	Composition, $560\Omega \pm 10\%$ , $\frac{1}{4}W$ .	77-TF995A/5
104	R107	Composition, $22\text{ k}\Omega \pm 10\%$ , $\frac{1}{4}W$ .	69-TM4826/5
105	R109	Composition, $2.2\text{ k}\Omega \pm 10\%$ , $\frac{1}{4}W$ .	69-TF995A/5
106	R110	Composition, $100\Omega \pm 10\%$ , $\frac{1}{4}W$ . (Part of Item 266)	10-TM3900/52
107	R111	Composition, $10\text{ k}\Omega \pm 10\%$ , $\frac{1}{4}W$ .	57-TM4826/5
108	R112	Wire-wound, Variable $20\text{ k}\Omega \pm 10\%$ , 2W.	81-TF995A/5
109	R113	Composition, $68\text{ k}\Omega \pm 10\%$ , $\frac{1}{2}W$ .	23-TM4800/2
110	R114	Composition, $100\text{ k}\Omega^* \pm 10\%$ , $\frac{1}{2}W$ .	145-TM4826/5
111	R115	Composition, $1\text{ k}\Omega \pm 10\%$ , $\frac{1}{4}W$ .	147-TM4826/5
112a	R116	Metal oxide, $180\Omega \pm 7\%$ TE, $\frac{3}{8}W$ .	60-TM4826/5
113	R117	Composition, $2.2\text{ k}\Omega \pm 10\%$ , $\frac{1}{4}W$ .	36-TM4299/2
114	R118	Composition, $22\text{ k}\Omega \pm 10\%$ , $\frac{1}{2}W$ .	43-TM4299/2
115	R119	Composition, $68\text{ k}\Omega^* \pm 10\%$ , $\frac{1}{4}W$ .	34-TM4299/2
116	R120	Composition, $33\text{ k}\Omega \pm 10\%$ , $\frac{1}{4}W$ .	35-TM4299/2
117	R121	Wire-wound, $950\Omega \pm 10\%$ , 1W.	82-TF995A/5
118	R122	Composition, $33\text{ k}\Omega \pm 10\%$ , $\frac{1}{2}W$ .	44-TM4299/2
119a	R123	Composition, $68\text{ k}\Omega \pm 10\%$ , $\frac{1}{4}W$ .	66-TF995A/5
120	R124	Wire-wound, Variable $5\text{ k}\Omega$ .	134-TF995A/5
121	R125	Composition, $2.2\text{ k}\Omega \pm 10\%$ , $\frac{1}{4}W$ .	135-TF995A/5
122	R126	Composition, $1\text{ M}\Omega \pm 10\%$ , $\frac{1}{4}W$ .	59-TF995A/5
121/1	R127	Variable, $47\text{ k}\Omega$ , $\frac{1}{4}W$ .	14-TM4943DG
121/2	R128	Variable, $47\text{ k}\Omega$ , $\frac{1}{4}W$ .	14-TM4943DG
121/3	R129	Variable, $100\text{ k}\Omega$ , $\frac{1}{4}W$ .	15-TM4943DG

\* Nominal value; actual value determined during calibration.

SOS Item No.	Circuit Ref.	Description	Works Ref.
122/4	R130	Variable, 47 k $\Omega$ , $\frac{1}{4}$ W.	14-TM4943DG
122/5	R131	Composition, 1 k $\Omega$ , Variable, 1W.	152-TM4826/5
122/6	R132	Composition, 100 k $\Omega$ , Variable, $\frac{1}{4}$ W.	23-TM6830/1
122/7	R133	Composition, 470 k $\Omega$ , Variable, $\frac{1}{4}$ W.	22-TM6830/1
122/8	R134	Composition, 10 k $\Omega$ , Variable, 1W.	149-TM4826/5
122/9	R135	Metal oxide, 47 k $\Omega$ $\pm$ 7% TE, $\frac{3}{8}$ W.	24552-126
122/10	R136	Composition, 47 k $\Omega$ , Variable, $\frac{1}{4}$ W.	17-TM4706/1
122/11	R137	Metal oxide, 22 k $\Omega$ $\pm$ 7% TE, $\frac{3}{8}$ W.	24552-118
122/12	R138	Composition, 47 k $\Omega$ , Variable, $\frac{1}{4}$ W.	17-TM4706/1
122/13	R139	Metal oxide, 3.9 k $\Omega$ $\pm$ 7% TE, $\frac{3}{8}$ W.	24552-096
122/14	R140	Composition, 10 k $\Omega$ , Variable, $\frac{1}{4}$ W.	16-TM4706/1
124a	R151	Metal oxide, 100 k $\Omega$ $\pm$ 7% TE, $\frac{3}{8}$ W.	18-TM6830/1
125a	R152	Metal oxide, 270 k $\Omega$ $\pm$ 7% TE, $\frac{3}{8}$ W.	17-TM6830/1
127	R154	Carbon, High Stability, 10 k $\Omega$ $\pm$ 1%, $\frac{1}{4}$ W.	121-TF995A/5
128	R155	Carbon, High Stability, 10 k $\Omega$ $\pm$ 1%, $\frac{1}{4}$ W.	121-TF995A/5
129	R156	Carbon, High Stability, 10 k $\Omega$ $\pm$ 1%, $\frac{1}{4}$ W.	121-TF995A/5
130	R157	Carbon, High Stability, 10 k $\Omega$ $\pm$ 1%, $\frac{1}{4}$ W.	121-TF995A/5
131	R158	Carbon, High Stability, 10 k $\Omega$ $\pm$ 1%, $\frac{1}{4}$ W.	121-TF995A/5
132	R159	Carbon, High Stability, 10 k $\Omega$ $\pm$ 1%, $\frac{1}{4}$ W.	121-TF995A/5
133	R160	Carbon, High Stability, 10 k $\Omega$ $\pm$ 1%, $\frac{1}{4}$ W.	121-TF995A/5
134	R161	Carbon, High Stability, 10 k $\Omega$ $\pm$ 1%, $\frac{1}{4}$ W.	121-TF995A/5
135	R162	Wire-wound, Variable, 25 k $\Omega$ , 3W.	116-TF995A/5
136a	R163	Composition, 82 k $\Omega$ *, $\frac{1}{4}$ W.	122-TF995A/5
137	R164	Composition, 100 k $\Omega$ $\pm$ 10%, $\frac{1}{2}$ W.	137-TF995A/5
138	R165	Composition, 470 $\Omega$ $\pm$ 10%, $\frac{1}{4}$ W.	63-TF995A/5
139	R166	Composition, 10 k $\Omega$ $\pm$ 10%, $\frac{1}{4}$ W.	136-TF995A/5
140	R167	Carbon, High Stability, 10 k $\Omega$ $\pm$ 5%, $\frac{1}{4}$ W.	138-TF995A/5
141	R168	Composition, 1 M $\Omega$ $\pm$ 10%, $\frac{1}{4}$ W.	15-TM4943BR
141/1a	R169	Carbon, 470 k $\Omega$ $\pm$ 10%, $\frac{1}{4}$ W.	24342-552
141/2	R170	Composition, 3.3 M $\Omega$ $\pm$ 10%, $\frac{1}{4}$ W.	70-TF995A/5

\* Nominal value; actual value determined during calibration.



SOS Item No.	Circuit Ref.	Description	Works Ref.
<b>CAPACITORS</b>			
142a	C1	Paper, 0.1 $\mu\text{F}$ $\pm$ 10%, 350 V d.c.	26134-455
143a	C2	Paper, 0.1 $\mu\text{F}$ $\pm$ 10%, 350 V d.c.	26134-455
144	C3	Mica, Special Assembly, 100 $\mu\text{F}$ , Nominal.	2-TM4826/5
145	C4	Mica, 100 $\mu\text{F}$ $\pm$ 10%, 350 V d.c.	117-TM4826/5
146	C5	Mica, 100 $\mu\text{F}$ $\pm$ 10%, 350 V d.c.	117-TM4826/5
147	C6	Paper, 0.02 $\mu\text{F}$ , 350 V d.c.	12-TM480022
148	C7	Ceramic, 22 $\mu\text{F}$ $\pm$ 20%, 500 V d.c.	71-TM4826/5
149	C8	Mica, 100 $\mu\text{F}$ $\pm$ 10%, 350 V d.c.	95-TF995A/5
150	C9	Mica, 100 $\mu\text{F}$ $\pm$ 20%, 350 V d.c.	26252-156
151	C10	Mica, Special Assembly, 100 $\mu\text{F}$ , Nominal.	2-TM4826/5
152	C12	Mica, Special Assembly, 100 $\mu\text{F}$ , Nominal.	2-TM4826/5
153	C13	Mica, 100 $\mu\text{F}$ $\pm$ 10%, 350 V d.c.	117-TM4826/5
154	C14	Paper, 2 $\mu\text{F}$ $\pm$ 25%, 250 V d.c.	87-TF995A/5
155	C15	Paper, 0.01 $\mu\text{F}$ $\pm$ 20%, 400 V d.c.	13-TM4800/2
156	C16	Paper, 0.01 $\mu\text{F}$ $\pm$ 25%, 400 V d.c.	15-TM4800/2
157a	C17	Paper, 0.1 $\mu\text{F}$ $\pm$ 10%, 350 V d.c.	26134-455
158a	C18	Paper, 0.1 $\mu\text{F}$ $\pm$ 10%, 350 V d.c.	26134-455
159	C19	Mica, Special Assembly, 100 $\mu\text{F}$ , Nominal.	3-TM4826/5
160a	C20	Ceramic, 0.01 $\mu\text{F}$ -20% +80%, 350 V d.c.	135-TM4826/5
161	C21	Ceramic, 0.001 $\mu\text{F}$ $\pm$ 20%, 400 V d.c. (Included in Item 247)	12-TM3900/75
162	C22	Mica, Special Assembly, 100 $\mu\text{F}$ , Nominal. (Included in Item 247)	9-TM3900/75
163	C23	Mica, 100 $\mu\text{F}$ $\pm$ 10%, 350 V d.c.	20-TM3900/75
164	C24	Paper, 0.001 $\mu\text{F}$ $\pm$ 20%, 600 V d.c.	91-TM4826/5
165	C25	Mica, 39 $\mu\text{F}$ $\pm$ 5%, 750 V d.c.	85-TM4826/5
166a	C26	Paper, 0.1 $\mu\text{F}$ $\pm$ 10%, 350 V d.c.	26134-455
167	C27	Paper, 0.001 $\mu\text{F}$ $\pm$ 20%, 600 V d.c.	91-TM4826/5
168	C28	Paper, 0.01 $\mu\text{F}$ $\pm$ 20%, 350 V d.c.	83-TM4826/5
169	C29	Mica, 47 $\mu\text{F}$ $\pm$ 20%, 350 V d.c. (Included in Item 248)	9-TM3900/74
170	C30	Ceramic, 10 $\mu\text{F}$ * $\pm$ 20%, 500 V d.c.	89-TM4826/5
171	C31	Ceramic, 100 $\mu\text{F}$ $\pm$ 5%, 750 V pk.	88-TM4826/5

\* Nominal value; actual value determined during calibration.

<i>SOS Item No.</i>	<i>Circuit Ref.</i>	<i>Description</i>	<i>Works Ref.</i>
172	C32	Paper, 2 $\mu\text{F} \pm 25\%$ , 150 V d.c.	151-TM4826/5
173	C33	Ceramic, 1 $\mu\mu\text{F} \pm 20\%$ , 500 V d.c.	82-TM4826/5
174		Two-section ganged capacitor complete with trimmers; includes C34, C35, C46 and C47.	TC21478/1
175	C34	Air, Variable, 14-200 $\mu\mu\text{F}$ , part of Item 174.	
176	C35	Air, Trimmer, 3-30 $\mu\mu\text{F}$ , part of Item 174.	
177	C36	Ceramic, 47 $\mu\mu\text{F} \pm 20\%$ , 500 V d.c.	76-TM4826/5
178a	C37	Paper, 0.1 $\mu\text{F} \pm 10\%$ , 350 V d.c.	26134-455
179	C38	Ceramic, 100 $\mu\mu\text{F} -0\%, +100\%$ , 500 V d.c.	84-TM4826/5
180	C39	Paper, 0.01 $\mu\text{F} \pm 20\%$ , 350 V d.c.	11-TM3900/52
181	C40	Air, Trimmer, 1.25-10 $\mu\mu\text{F}$ .	116-TM4826/5
182	C41	Ceramic, 3.3 $\mu\mu\text{F}^* \pm 10\%$ , 500 V d.c.	75-TM4826/5
183	C42	Ceramic, 4700 $\mu\mu\text{F} -0 + 100\%$ , 500 V d.c.	92-TM4826/5
184	C43	Ceramic, 5 $\mu\mu\text{F} \pm 20\%$ , 750 V d.c.	134-TM4826/5
185	C44	Ceramic, 10 $\mu\mu\text{F} \pm 10\%$ , 750 V d.c.	77-TM4826/5
186	C45	Paper, 0.5 $\mu\text{F} \pm 25\%$ , 150 V d.c.	150-TM4826/5
	C46	Air, Variable, 7-100 $\mu\mu\text{F}$ , part of Item 174.	
	C47	Air, Trimmer, 2-8 $\mu\mu\text{F}$ , part of Item 174.	
187	C48	Ceramic, 100 $\mu\mu\text{F} -0\%, + 100\%$ , 500 V d.c.	84-TM4826/5
188	C49	Ceramic, 22 $\mu\mu\text{F} \pm 20\%$ , 500 V d.c.	87-TM4826/5
189	C50	Ceramic, 47 $\mu\mu\text{F} \pm 20\%$ , 500 V d.c.	73-TM4826/5
190	C51	Mica, 100 $\mu\mu\text{F} \pm 10\%$ , 350 V d.c.	117-TM4826/5
191	C52	Mica, Special Assembly, 100 $\mu\mu\text{F}$ , Nominal.	4-TM4826/5
192	C53	Electrolytic, 8 $\mu\text{F} -20\% + 50\%$ , 150 V d.c.	103-TF995A/5
193	C54	Paper, 0.1 $\mu\text{F} \pm 25\%$ , 250 V d.c.	93-TF995A/5
194	C55	Ceramic, 33 $\mu\mu\text{F} \pm 20\%$ , 500 V d.c.	72-TM4826/5
195	C56	Mica, 100 $\mu\mu\text{F} \pm 10\%$ , 350 V d.c.	117-TM4826/5
196	C57	Mica, Special Assembly, 100 $\mu\mu\text{F}$ , Nominal.	124-127-TM4826/5
197	C58	Electrolytic, 8 $\mu\text{F} -20\% + 50\%$ , 450 V d.c.	33-TM4299/2
198	C59	Air, Trimmer, 1.25-10 $\mu\mu\text{F}$ .	116-TM4826/5
199	C60	Ceramic, Stand-off, 820 $\mu\mu\text{F} \pm 20\%$ , 750 V d.c.	79-TM4826/5
200	C61	Ceramic, 5 $\mu\mu\text{F} \pm 20\%$ , 500 V d.c.	118-TM4826/5
201a	C62	Electrolytic, 32 $\mu\text{F} -20\% + 50\%$ , 450 V d.c.	26427-724
202	C63	Paper, 0.01 $\mu\text{F} \pm 20\%$ , 350 V d.c.	83-TM4826/5
203	C64	Ceramic, 100 $\mu\mu\text{F} \pm 10\%$ , 500 V d.c.	81-TM4826/5

\* Nominal value; actual value determined during calibration.

SOS Item No.	Circuit Ref.	Description	Works Ref.
204		Three-section ganged capacitor complete with trimmers; includes C65, C66, C75, C76, C81 and C83.	TC21478/2
	C65	Air, Variable, 7-100 $\mu\mu\text{F}$ ; part of Item 204.	
	C66	Air, Trimmer, 2-8 $\mu\mu\text{F}$ ; part of Item 204.	
205	C67	Ceramic, 22 $\mu\mu\text{F} \pm 20\%$ , 500 V d.c.	87-TM4826/5
206	C68	Paper, 0.01 $\mu\text{F} \pm 20\%$ , 350 V d.c.	83-TM4826/5
207a	C69	Electrolytic, 16 $\mu\text{F} -20\% + 50\%$ , 450 V d.c.	26427-717
208	C70	Ceramic, 100 $\mu\mu\text{F} -0\%, + 100\%$ , 500 V d.c.	84-TM4826/5
208/1	C71	Electrolytic 8 $\mu\text{F} -20\% + 50\%$ , 450 V d.c.	26415-320
209a	C72	Ceramic, Stand-off, 820 $\mu\mu\text{F} \pm 20\%$ , 500 V d.c.	79-TM4826/5
210	C73	Ceramic, 5 $\mu\mu\text{F} \pm 20\%$ , 500 V d.c.	118-TM4826/5
211	C74	Ceramic, 100 $\mu\mu\text{F} \pm 10\%$ , 500 V d.c.	81-TM4826/5
	C75	Air, Variable, 7-100 $\mu\mu\text{F}$ , part of Item 204.	
	C76	Air, Trimmer, 2-8 $\mu\mu\text{F}$ , part of Item 204.	
214	C77	Ceramic, 10 $\mu\mu\text{F} \pm 20\%$ , 500 V d.c.	80-TM4826/5
215	C78	Ceramic, 100 $\mu\mu\text{F} -0\%, + 100\%$ , 500 V d.c.	84-TM4826/5
216	C79	Paper, 6 $\mu\text{F} \pm 20\%$ , 150 V d.c.	79-TF995A/5
217	C80	Ceramic, 100 $\mu\mu\text{F} \pm 10\%$ , 500 V d.c.	81-TM4826/5
	C81	Air, Variable, 7-75 $\mu\mu\text{F}$ , part of Item 204.	
218	C82	Ceramic, Stand-off, 820 $\mu\mu\text{F} \pm 20\%$ , 750 V d.c.	79-TM4826/5
	C83	Air, Trimmer, 2-8 $\mu\mu\text{F}$ , part of Item 204.	
219a	C84	Paper, 100 $\mu\mu\text{F} \pm 2\%$ , 750 V d.c.	26324-897
220a	C85	Paper, 100 $\mu\mu\text{F} \pm 2\%$ , 750 V d.c.	26324-897
221a	C86	Paper, 100 $\mu\mu\text{F} \pm 2\%$ , 750 V d.c.	26324-897
222a	C87	Paper, 100 $\mu\mu\text{F} \pm 2\%$ , 750 V d.c.	26324-897
223	C88	Ceramic, 820 $\mu\mu\text{F} \pm 20\%$ , 350 V d.c.	41-TM4297A
224	C89	Ceramic, 820 $\mu\mu\text{F} \pm 20\%$ , 350 V d.c.	41-TM4297A
225	C90	Ceramic, 820 $\mu\mu\text{F} \pm 20\%$ , 350 V d.c.	41-TM4297A
226a	C91	Paper, 0.1 $\mu\text{F} \pm 10\%$ , 350 V d.c.	26134-455
227	C92	Paper, 0.25 $\mu\text{F} \pm 20\%$ , 275 V a.c.	32-TM4299/2
228	C93	Ceramic, 15 $\mu\mu\text{F}^* \pm 20\%$ , 500 V d.c.	119-TM4826/5
229	C94	Ceramic, 120 $\mu\mu\text{F} \pm 10\%$ , 750 V d.c.	74-TM4826/5
230	C95	Ceramic, 68 $\mu\mu\text{F} \pm 10\%$ , 750 V d.c.	90-TM4826/5

\* Nominal value; actual value determined during calibration.

<i>SOS Item No.</i>	<i>Circuit Ref.</i>	<i>Description</i>	<i>Works Ref.</i>
231a	C96	Ceramic, 330 $\mu\mu\text{F}^* \pm 20\%$ , 500 V d.c.	141-TF995A/5
232	C97	Paper, 0.05 $\mu\text{F} \pm 20\%$ , 350 V d.c.	142-TF995A/5
233	C98	Paper, 2 $\mu\text{F} \pm 25\%$ , 150 V d.c.	10-TM6830/1
234	C99	Paper, 2 $\mu\text{F} \pm 25\%$ , 150 V d.c.	10-TM6830/1
235	C100	Ceramic, 4,700 $\mu\mu\text{F} + 100\%$ , $-0\%$ , 500 V d.c.	92-TM4826/5
236	C101	Paper, 0.25 $\mu\text{F}$ , 400 V d.c.	11-TM6830/1
237	C102	Paper, 0.01 $\mu\text{F}$ , 400 V d.c.	14-TM6830/1
238	C103	Paper, 0.25 $\mu\text{F} \pm 25\%$ , 400 V d.c.	13-TM6830/1
239a	C104	Paper, 0.05 $\mu\text{F} \pm 25\%$ , 400 V d.c.	12-TM6830/1
240	C105	Paper, 2 $\mu\text{F} \pm 25\%$ , 150 V d.c.	10-TM6830/1
241	C106	Ceramic, 3.3 $\mu\mu\text{F} \pm 10\%$ , 500 V d.c.	75-TM4826/5
242	C107	Paper, 0.1 $\mu\text{F} \pm 20\%$ , 350 V d.c.	78-TM4826/5
242/1	C108	Paper, 0.01 $\mu\text{F} \pm 20\%$ , 400 V d.c.	24-TM4800/6
242/2	C109	Paper, 0.005 $\pm 10\%$ , 250 V d.c.	26174-141
242/4	C111	Paper, 0.05 $\mu\text{F}^* \pm 20\%$ , 350 V d.c.	26114-458
242/5	C112	Paper, 0.002 $\mu\text{F}^* \pm 20\%$ , 350 V d.c.	26174-130
242/6	C113	Paper, 0.005 $\mu\text{F}^* \pm 20\%$ , 350 V d.c.	26112-419

For Service Manuals Contact  
**MAURITRON TECHNICAL SERVICES**  
 8 Cherry Tree Rd, Cinnor  
 Oxon OX9 4QY  
 Tel: 01844-351694 Fax: 01844-352354  
 Email: enquiries@mauritron.co.uk

\* *Nominal value; actual value determined during calibration.*

<i>SOS Item No.</i>	<i>Circuit Ref.</i>	<i>Description</i>	<i>Works Ref.</i>
<b>INDUCTORS</b>			
243	L1	R.F. Filter Inductor.	TM4087/14
244	L2	R.F. Filter Inductor.	TM4087/14
245	L3	R.F. Inductor.	TB16363/27
246	L4	R.F. Filter Inductor.	TM4087/14
247		Main portion of three-section filter assembly; includes L6 and L7, and Items 161 and 162.	TM3900/75
	L6	R.F. Filter Inductor; part of Item 247.	
	L7	R.F. Filter Inductor; part of Item 247.	
248	L8	Screened R.F. Inductor Assembly; includes Item 169.	TM3900/74
249	L9	Modulation Choke.	TM4159/1
250	L10	30-Mc/s Oscillator Inductor.	TB23173/1
251	L11	Screened R.F. Inductor Assembly.	TM4087/14
252	L14	R.F. Inductor.	TB23173/3
253	L15	R.F. Inductor.	TB23173/4
254	L16	H.T. Smoothing Choke.	TM5172/31
255	L17	H.T. Smoothing Choke.	TM5172/31
256	L18	Multiplier Tuning Inductor, 27-55 Mc/s.	TA22011
257	L19	R.F. Inductor; part of Item 59.	TB23173/10
258	L21	R.F. Inductor; part of Item 53.	TB23173/9
259	L22	Multiplier Tuning Inductor, 54-110 Mc/s.	TB20309/1
260	L23	Multiplier Tuning Inductor, 108-220 Mc/s.	TE23048/11
261	L24	R.F. Inductor (mains filter).	TB22722/21
262	L25	R.F. Inductor (mains filter).	TB22722/21
263	L26	Filter Inductor.	TB23173/39
<b>TRANSFORMERS</b>			
264	T1	A.F. Oscillator Transformer.	TM4085/2
265	T2	Master Oscillator R.F. Transformer, 4.5-9 Mc/s.	TM3900/95
266	T3	Multiplier R.F. Transformer, 13.5-27 Mc/s. (Includes Items 29 and 106)	TM3900/52
267	T4	Mains Transformer.	TM5150/25
268	T5	R.F. Output Transformer, 2-13.5 Mc/s.	TB23173/5

<i>SOS Item No.</i>	<i>Circuit Ref.</i>	<i>Description</i>	<i>Works Ref.</i>
<b>SWITCHES</b>			
269	S1	Rotary, 8 pole, 5 position, 4 wafer.	TC4428/373
270	S2	Rotary, 10 pole, 5 position, 4 wafer.	TC4428/475
271	S3	Lever-Actuated Rotary, 2 pole, 3 position, 2 wafer, biased to mid-position; includes bakelite handle.	TC4428/342
272	S4	Toggle, 2 pole, 2 position.	TB23903/2
273	S5	Rotary, 2 pole, 2 position, single wafer.	96-TM4826/5
274	S6	Rotary, 4 pole, 2 position, single active wafer, with extra dummy wafer.	TC4428/344
275	S10	Rotary, 2 pole, 5 position, 1 wafer.	117-TF995A/5
276	S11	Toggle, 2 pole, 2 position.	TB23903/2
277	S12	Rotary, 2 pole, 3 position, 2 wafer.	118-TF995A/5
<b>VALVES, VALVE HOLDERS, AND RETAINERS</b>			
278	V1	6AK6, Pentode.	47-TF995A/5
279		Holder, for V1.	TB26904/2
280		Retainer, for V1.	PC17501/2
281	V2	6AK5, Pentode.	101-TM4826/5
282		Holder, for V2.	TB26904/2
283		Retainer, for V2.	PC17501/2
284	V3	EF86, Pentode.	163-TM4826/5
285		Holder, for V3.	TB26902/2
286		Retainer, for V3.	PC17502/2
<b>For Service Manuals Contact MAURITRON TECHNICAL SERVICES 8 Cherry Tree Rd, Chinnor Oxon OX9 4QY Tel: 01844-351694 Fax: 01844-352554 Email: enquiries@mauritron.co.uk</b>			
287	V4	6AK5, Pentode.	101-TM4826/5
288		Holder, for V4.	TB26904
289		Retainer, for V4.	PC17501/1
290	V5	6AU6, Pentode.	49-TF995A/5
291		Holder, for V5.	60-TF995A/5
292		Retainer, for V5.	57-TF995A/5
293	V6	6AK5, Pentode.	101-TM4826/5
294		Holder, for V6.	TB26904
295		Retainer, for V6.	PC17502/2

## SECTION 7

<i>SOS Item No.</i>	<i>Circuit Ref.</i>	<i>Description</i>	<i>Works Ref.</i>
296 297 298	V7	12AT7, Double Triode. Holder, for V7. Retainer, for V7.	103-TM4826/5 TB26905/2 PC17502/2
299 300 301	V8	6AK5, Pentode. Holder, for V8. Retainer, for V8.	101-TM4826/5 TB26904 PC17502/2
302 303 304	V9	OA2, Voltage Stabilizer. Holder, for V9. Retainer, for V9.	48-TF995A/5 TB26904/2 PC17501/2
305 306 307	V10	6AK5, Pentode. Holder, for V10. Retainer, for V10.	101-TM4826/5 TB26904 PC17501/1
308 309 310	V11	5Z4G, Full-Wave Rectifier. Holder, for V11. Retainer, for V11.	16-TM4299/2 PC81814/1 TC22774/12
311 312 313	V12	6AK5, Pentode. Holder, for V12. Retainer, for V12.	101-TM4826/5 TB26904 PC17501/1
314 315 316	V13	12AT7, Double Triode. Holder, for V13. Retainer, for V13.	46-TF995A/5 TB26902/2 PC17502/2
317 318 319	V14	5651, Voltage Stabilizer Holder, for V14. Retainer, for V14.	20-TM4299/2 TB26904/2 PC17501/2
320 321 322	V15	6AL5, Double Diode. Holder, for V15. Retainer, for V15.	21-TM4299/2 TB26904/2 PC17501/2

SOS Item No.	Circuit Ref.	Description	Works Ref.
<b>CRYSTALS</b>			
323	X1	Quartz Oscillator Crystal, 333.33 kc/s.	102-TM4826/5
324		Holder, for X1.	98-TM4826/5
325		Retainer, for X1.	99-TM4826/5
326	X2	CS2A, Silicon Rectifier.	44-TM4297/A
327		Retaining Contact, for X2.	TD27378/1
328	X3	CV425, Germanium Diode.	7A-TM4943BR
329	X4	CV425, Germanium Diode.	6A-TM4943BR
<b>LAMP</b>			
<b>For Service Manuals Contact</b> <b>MAURITRON TECHNICAL SERVICES</b> <b>8 Cherry Tree Rd, Chinnor</b> <b>Oxon OX9 4QY</b> <b>Tel: 01844-351694 Fax: 01844-352354</b> <b>Email: enquiries@mauritron.co.uk</b>			
330	PLP1	Pilot Lamp, 6.5 V, 0.3 A, M.E.S.	43-TF995A/5
331		Pilot Lamp Holder, with Red Lens.	42-TF995A/5
<b>FUSES AND HOLDERS</b>			
331/1	FS1	150-mA cartridge fuse.	57-TM4299/2
331/2	FS2/FS3	2-amp cartridge fuses.	58-TM4299/2
331/3	FS2/FS3	3-amp cartridge fuses (for use on 100 to 150 volts ranges only).	
331/4		Holder, for cartridge fuses.	59-TM4299/2
<b>METER</b>			
332	M1	0-100 $\mu$ A, Moving Coil, including clamping brackets.	TM3970/73
<b>PLUGS, SOCKETS, AND CONNECTING LEADS</b>			
333	PL1	Plug, 6-way.	18-TM4299/2
334	SKT1	Socket, 6-way.	55-TF995A/5
335		Mains Lead comprising 6-ft, 3-core Flexible Cable and 3-pin plug complete with Plastic Entry Sleeve.	TM2560AQ
336		75 $\Omega$ Type BNC Socket, coaxial, free.	30-TM4298/1
337		75 $\Omega$ Type BNC Socket, coaxial, fixed.	6-TM5551
338		50 $\Omega$ Type BNC Socket, coaxial, fixed.	7-TM5551
339		75 $\Omega$ Type BNC Plug (modified), coaxial, fixed.	8-TM5551 TC27665 TB26997/1
340		R.F. Output Cable, coaxial. 4 ft 6 in; includes Item 336.	38-TM4298/1
341a	J1	CRYSTAL CHECK Jack, including Telephone Plug.	23421-684
342		Bush, for Item 341.	TA19742



<i>SOS Item No.</i>	<i>Circuit Ref.</i>	<i>Description</i>	<i>Works Ref.</i>
<b>KNOBS, DRIVES, AND DIALS</b>			
343		Knobs, for TUNE and INC. FREQ. controls.	TB29569
344		COARSE TUNE control dial.	TB4691A/18
345		FINE TUNE control dial.	TB28875
346		COARSE INC. FREQ. control dial.	TB26194
347		FINE INC. FREQ. control dial.	TD27529/5
348		FREQUENCY DIAL. Pre-calibrated.	TB23189
349		Dial Escutcheon Mounting Ring.	TD20670/2
350		Dial Escutcheon (Chromium Plated), with Rubber Tubing.	TD20670/1
351		Gasket, to fit over Item 349.	8-TM4357/2
352		Window, including Movable Cursor Assembly, to fit in Item 350.	TC20735/2 TD20670/3 TA20726 TB6775/300 6-TM4357
353		Nylon Drive Cord.	12-TM4826/2
354		Knob, for SET MOD. FREQ. switch, S12.	TB25460
355		Knob, for MOD. SELECTOR switch, S1.	TB25460/2
356		Knob, for RANGE MC/S switch, S2.	TB25460/2
357		Knob, for DEVIATION—NORMAL/HIGH switch, S5.	TB25460/2
358		Knob, for DEVIATION RANGE switch, S6.	TB25460/2
359		Knob, for OUTPUT VOLTAGE attenuator.	TB17848/3
360		Knob, for MULTIPLY BY attenuator.	TB17848/3
361		Knob, for SET CARRIER control, R44.	TB23920/1
362		Knob, for SET MOD. control, R25.	TB23920/1

<i>SOS Item No.</i>	<i>Circuit Ref.</i>	<i>Description</i>	<i>Works Ref.</i>
<b>MISCELLANEOUS</b>			
363		Cover Plate, for R.F. Output Cable exit, in Right-Hand Handle Recess.	TA19721
364		Grommet, to fit in Item 363.	TA6515/1
365		Cable Saddle, to secure Item 340 to Item 363.	29-TF995A/5
366		Front Panel.	TD22009/5
367		Set of Eight Screws, complete with Black Fibre Washers for fixing Front Panel to case.	30-TF995A/5 TB6775/183
368		Terminal, EXT. MOD.	TB24330/5
369		Terminal, SYNC.	TB24330/5
370		Terminal, EARTH.	TB24330/5
371		Case Assembly complete with Handles and Feet.	TM4310 TC17659 TA11420
372		Handle Escutcheon. Two included in Item 371.	TC17659
373		Case Foot. Four included in Item 371.	TA11420
374		20-dB Step Attenuator Assembly; includes Items 68 to 79 inclusive, 223, 224, 225, 326, and 327.	TM4297A
375		2-dB Step Attenuator Assembly; includes Items 80 to 96 inclusive.	TM4298
376		20-dB ATTENUATOR PAD; includes Items 97 to 99 inclusive, and Items 298 and 300.	TM5552
377		52- and 75-ohm TERMINATING UNIT; includes Items 100 to 102 inclusive, and Items 337 to 339 inclusive.	TM5551
378		R.F. Unit Screening Cover.	26-TM4826/5
379		Contact Spring for earthing R.F. Unit Screening Cover.	TC-20321/3E
380		Set of three Hexagonal Wrenches for Socket Set Screws, sizes 2, 4, and 6BA; complete in linen bag.	104-TF995A/2
381		Operating and Maintenance Handbook.	OM995A/5

**For Service Manuals Contact**  
**MAURITRON TECHNICAL SERVICES**  
 8 Cherry Tree Rd, Chinnor  
 Oxon OX9 4GY  
**Tel: 01844-351894 Fax: 01844-352554**  
**Email: enquiries@m.murtron.co.uk**

## DECIBEL CONVERSION TABLE

<i>Ratio Down</i>		DECIBELS	<i>Ratio Up</i>	
VOLTAGE	POWER		VOLTAGE	POWER
1.0	1.0	0	1.0	1.0
·9886	·9772	·1	1.012	1.023
·9772	·9550	·2	1.023	1.047
·9661	·9333	·3	1.035	1.072
·9550	·9120	·4	1.047	1.096
·9441	·8913	·5	1.059	1.122
·9333	·8710	·6	1.072	1.148
·9226	·8511	·7	1.084	1.175
·9120	·8318	·8	1.096	1.202
·9016	·8128	·9	1.109	1.230
·8913	·7943	1.0	1.122	1.259
·8710	·7586	1.2	1.148	1.318
·8511	·7244	1.4	1.175	1.380
·8318	·6918	1.6	1.202	1.445
·8128	·6607	1.8	1.230	1.514
·7943	·6310	2.0	1.259	1.585
·7762	·6026	2.2	1.288	1.660
·7586	·5754	2.4	1.318	1.738
·7413	·5495	2.6	1.349	1.820
·7244	·5248	2.8	1.380	1.905
·7079	·5012	3.0	1.413	1.995
·6683	·4467	3.5	1.496	2.239
·6310	·3981	4.0	1.585	2.512
·5957	·3548	4.5	1.679	2.818
·5623	·3162	5.0	1.778	3.162
·5309	·2818	5.5	1.884	3.548
·5012	·2512	6	1.995	3.981
·4467	·1995	7	2.239	5.012
·3981	·1585	8	2.512	6.310
·3548	·1259	9	2.818	7.943
·3162	·1000	10	3.162	10.000
·2818	·07943	11	3.548	12.59
·2512	·06310	12	3.981	15.85
·2239	·05012	13	4.467	19.95
·1995	·03981	14	5.012	25.12
·1778	·03162	15	5.623	31.62

## DECIBEL CONVERSION TABLE (continued)

<i>Ratio Down</i>		DECIBELS	<i>Ratio up</i>	
VOLTAGE	POWER		VOLTAGE	POWER
·1585	·02512	16	6·310	39·81
·1413	·01995	17	7·079	50·12
·1259	·01585	18	7·943	63·10
·1122	·01259	19	8·913	79·43
·1000	·01000	20	10·000	100·00
·07943	6·310 × 10 <sup>-3</sup>	22	12·59	158·5
·06310	3·981 × 10 <sup>-3</sup>	24	15·85	251·2
·05012	2·512 × 10 <sup>-3</sup>	26	19·95	398·1
·03981	1·585 × 10 <sup>-3</sup>	28	25·12	631·0
·03162	1·000 × 10 <sup>-3</sup>	30	31·62	1,000
·02512	6·310 × 10 <sup>-4</sup>	32	39·81	1·585 × 10 <sup>3</sup>
·01995	3·981 × 10 <sup>-4</sup>	34	50·12	2·512 × 10 <sup>3</sup>
·01585	2·512 × 10 <sup>-4</sup>	36	63·10	3·981 × 10 <sup>3</sup>
·01259	1·585 × 10 <sup>-4</sup>	38	79·43	6·310 × 10 <sup>3</sup>
·01000	1·000 × 10 <sup>-4</sup>	40	100·00	1·000 × 10 <sup>4</sup>
7·943 × 10 <sup>-3</sup>	6·310 × 10 <sup>-5</sup>	42	125·9	1·585 × 10 <sup>4</sup>
6·310 × 10 <sup>-3</sup>	3·981 × 10 <sup>-5</sup>	44	158·5	2·512 × 10 <sup>4</sup>
5·012 × 10 <sup>-3</sup>	2·512 × 10 <sup>-5</sup>	46	199·5	3·981 × 10 <sup>4</sup>
3·981 × 10 <sup>-3</sup>	1·585 × 10 <sup>-5</sup>	48	251·2	6·310 × 10 <sup>4</sup>
3·162 × 10 <sup>-3</sup>	1·000 × 10 <sup>-5</sup>	50	316·2	1·000 × 10 <sup>5</sup>
2·512 × 10 <sup>-3</sup>	6·310 × 10 <sup>-6</sup>	52	398·1	1·585 × 10 <sup>5</sup>
1·995 × 10 <sup>-3</sup>	3·981 × 10 <sup>-6</sup>	54	501·2	2·512 × 10 <sup>5</sup>
1·585 × 10 <sup>-3</sup>	2·512 × 10 <sup>-6</sup>	56	631·0	3·981 × 10 <sup>5</sup>
1·259 × 10 <sup>-3</sup>	1·585 × 10 <sup>-6</sup>	58	794·3	6·310 × 10 <sup>5</sup>
1·000 × 10 <sup>-3</sup>	1·000 × 10 <sup>-6</sup>	60	1,000	1·000 × 10 <sup>6</sup>
5·623 × 10 <sup>-4</sup>	3·162 × 10 <sup>-7</sup>	65	1·778 × 10 <sup>3</sup>	3·162 × 10 <sup>6</sup>
3·162 × 10 <sup>-4</sup>	1·000 × 10 <sup>-7</sup>	70	3·162 × 10 <sup>3</sup>	1·000 × 10 <sup>7</sup>
1·778 × 10 <sup>-4</sup>	3·162 × 10 <sup>-8</sup>	75	5·623 × 10 <sup>3</sup>	3·162 × 10 <sup>7</sup>
1·000 × 10 <sup>-4</sup>	1·000 × 10 <sup>-8</sup>	80	1·000 × 10 <sup>4</sup>	1·000 × 10 <sup>8</sup>
5·623 × 10 <sup>-5</sup>	3·162 × 10 <sup>-9</sup>	85	1·778 × 10 <sup>4</sup>	3·162 × 10 <sup>8</sup>
3·162 × 10 <sup>-5</sup>	1·000 × 10 <sup>-9</sup>	90	3·162 × 10 <sup>4</sup>	1·000 × 10 <sup>9</sup>
1·000 × 10 <sup>-5</sup>	1·000 × 10 <sup>-10</sup>	100	1·000 × 10 <sup>5</sup>	1·000 × 10 <sup>10</sup>
3·162 × 10 <sup>-6</sup>	1·000 × 10 <sup>-11</sup>	110	3·162 × 10 <sup>5</sup>	1·000 × 10 <sup>11</sup>
1·000 × 10 <sup>-6</sup>	1·000 × 10 <sup>-12</sup>	120	1·000 × 10 <sup>6</sup>	1·000 × 10 <sup>12</sup>
3·162 × 10 <sup>-7</sup>	1·000 × 10 <sup>-13</sup>	130	3·162 × 10 <sup>6</sup>	1·000 × 10 <sup>13</sup>
1·000 × 10 <sup>-7</sup>	1·000 × 10 <sup>-14</sup>	140	1·000 × 10 <sup>7</sup>	1·000 × 10 <sup>14</sup>

# Section 6 Component layout illustrations

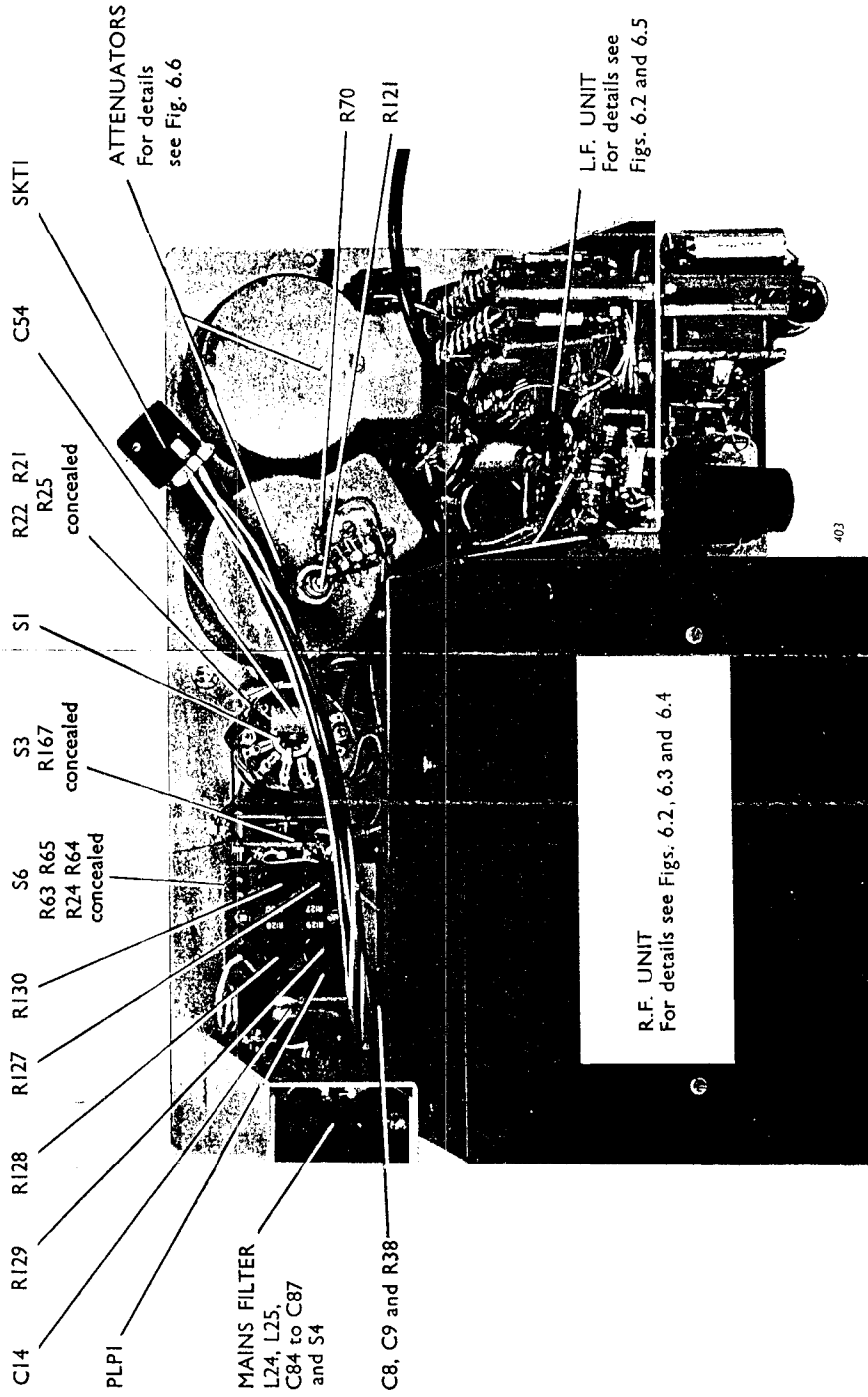

GENERAL UNDERSIDE VIEW  
FROM REAR (CASE REMOVED)

Fig. 6.1

For Service Manuals Contact  
 MAURITRON TECHNICAL SERVICES  
 8 Cherry Tree Rd, Chinnor  
 Oxon OX9 4QY  
 Tel:- 01844-351694 Fax:- 01844-352554  
 Email:- enquiries@mauritron.co.uk

Fig. 6.2

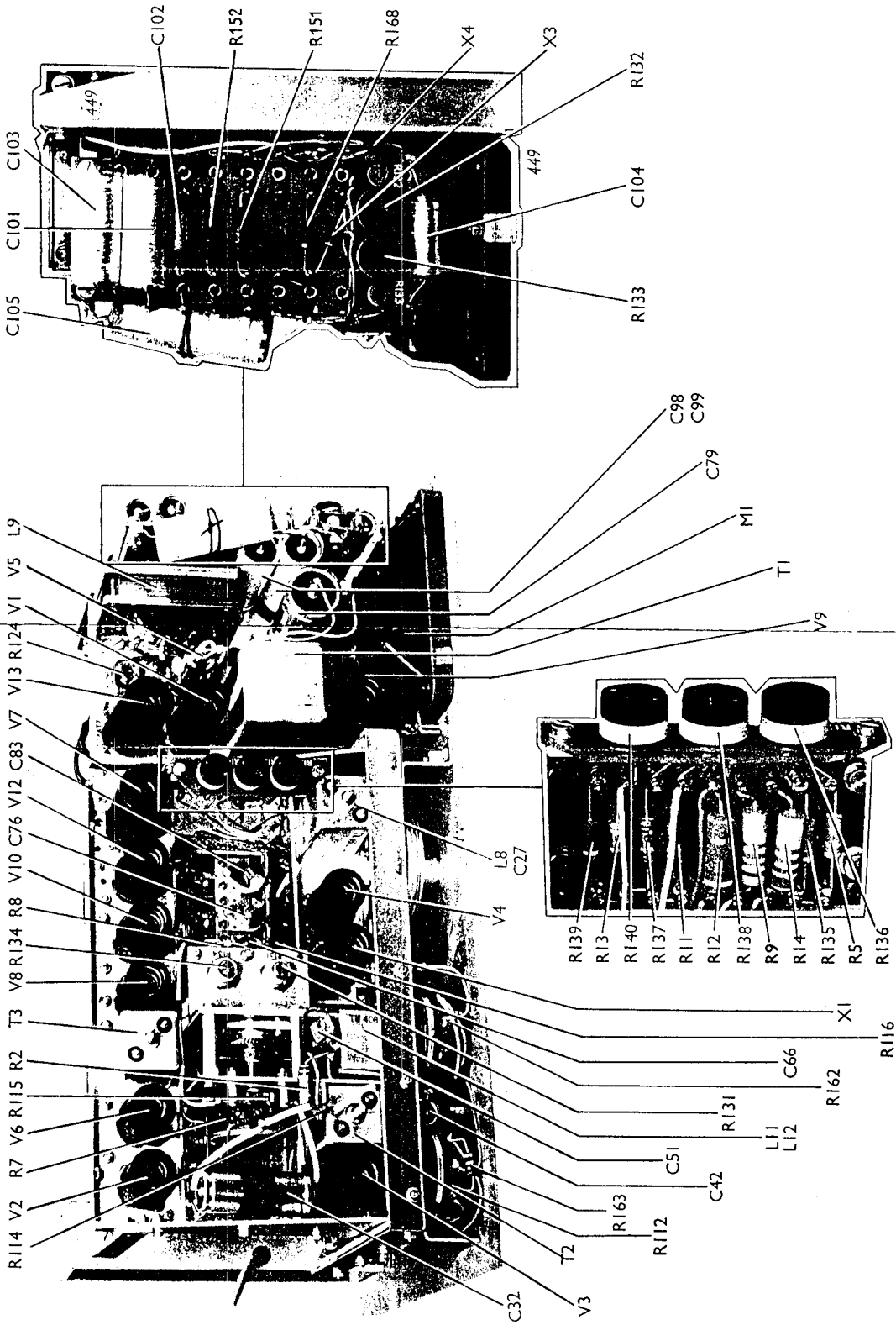

L.F. AND R.F. UNITS  
 TOP VIEW WITH R.F. UNIT SCREENING COVER REMOVED

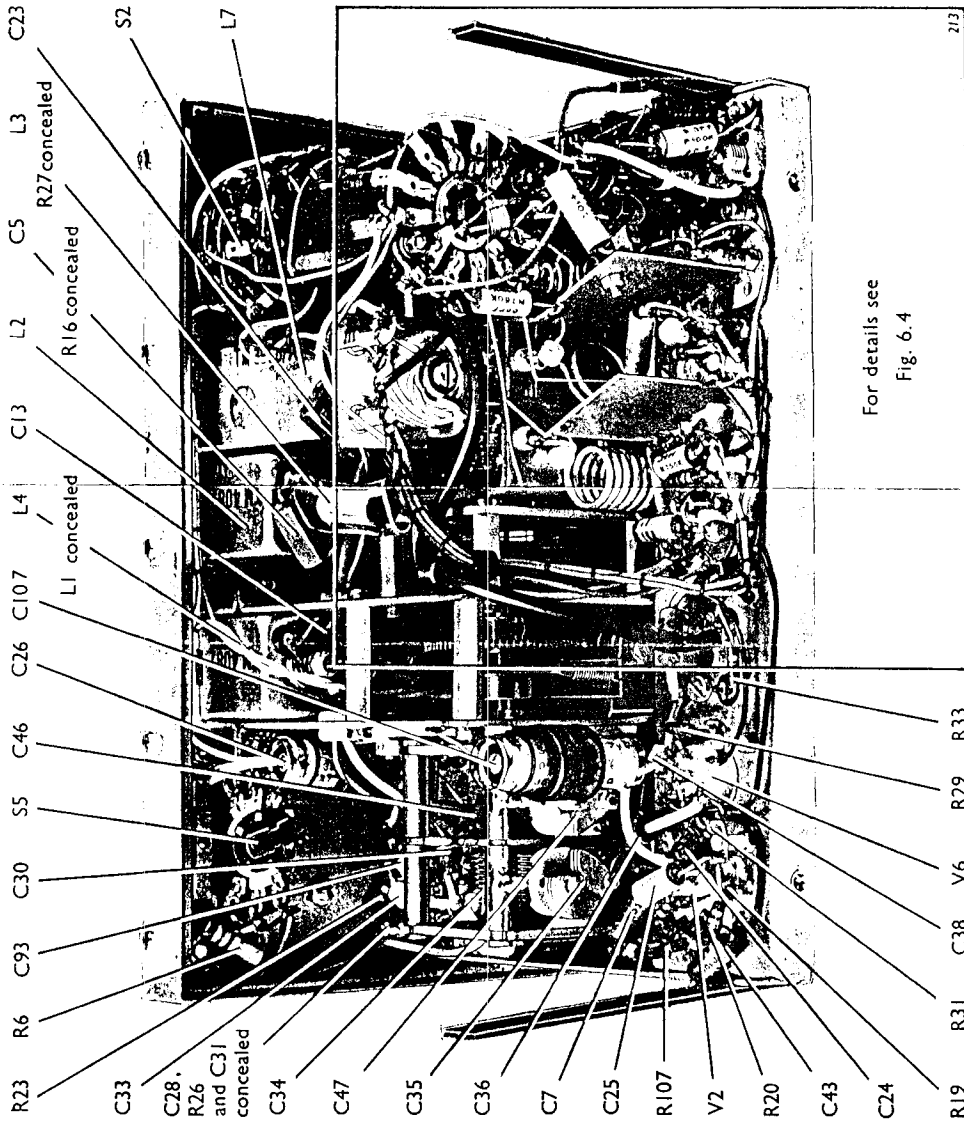

R.F. UNIT  
GENERAL UNDERSIDE VIEW

Fig. 6.3





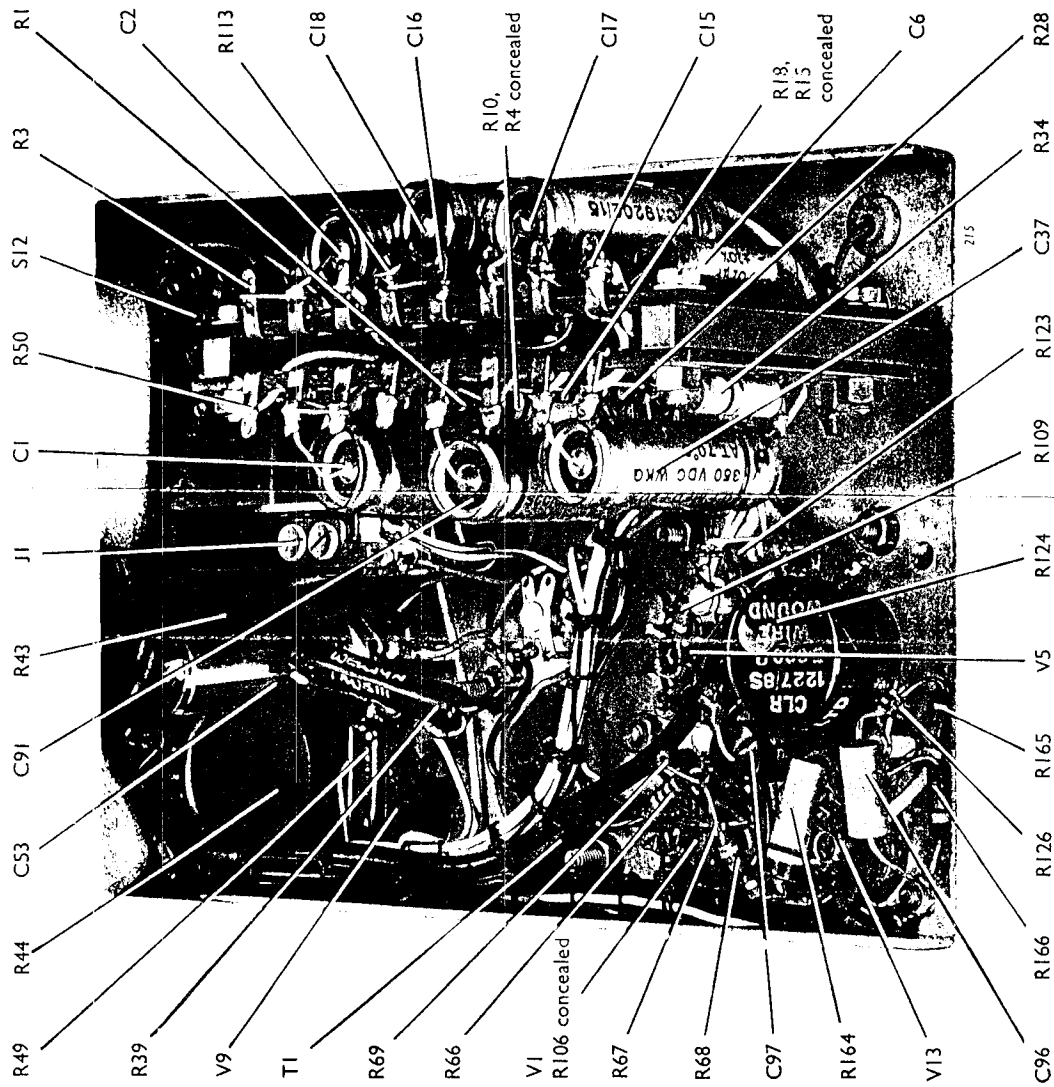

L.F. UNIT  
UNDERSIDE VIEW

Fig. 6-5

For Service Manuals Contact  
MAURITRON TECHNICAL SERVICES  
8 Cherry Tree Rd, Chinnor  
Oxon OX9 4QY  
Tel:- 01844-351694 Fax:- 01844-352554  
Email:- enquiries@mauritron.co.uk

Fig. 6.6

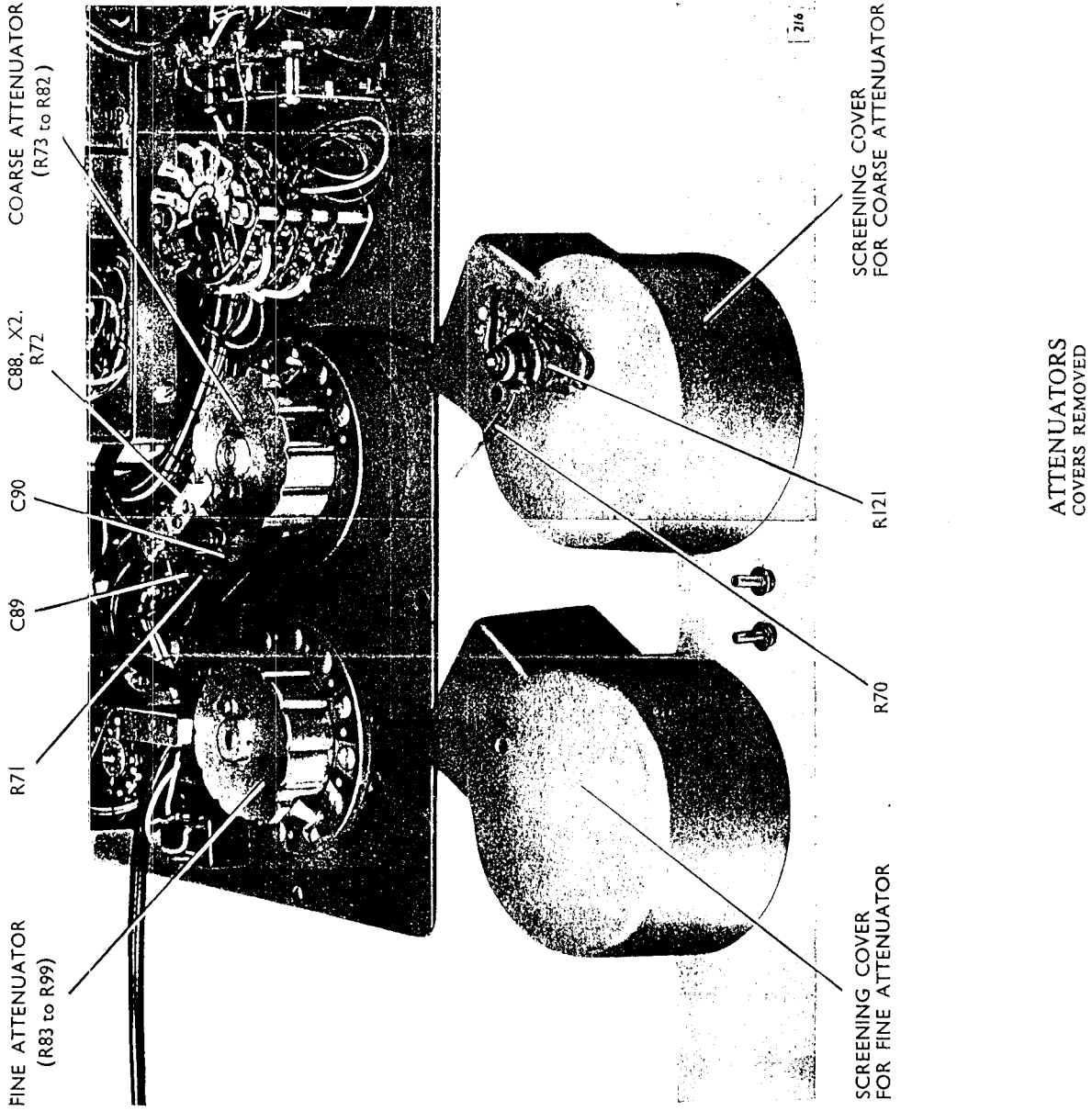

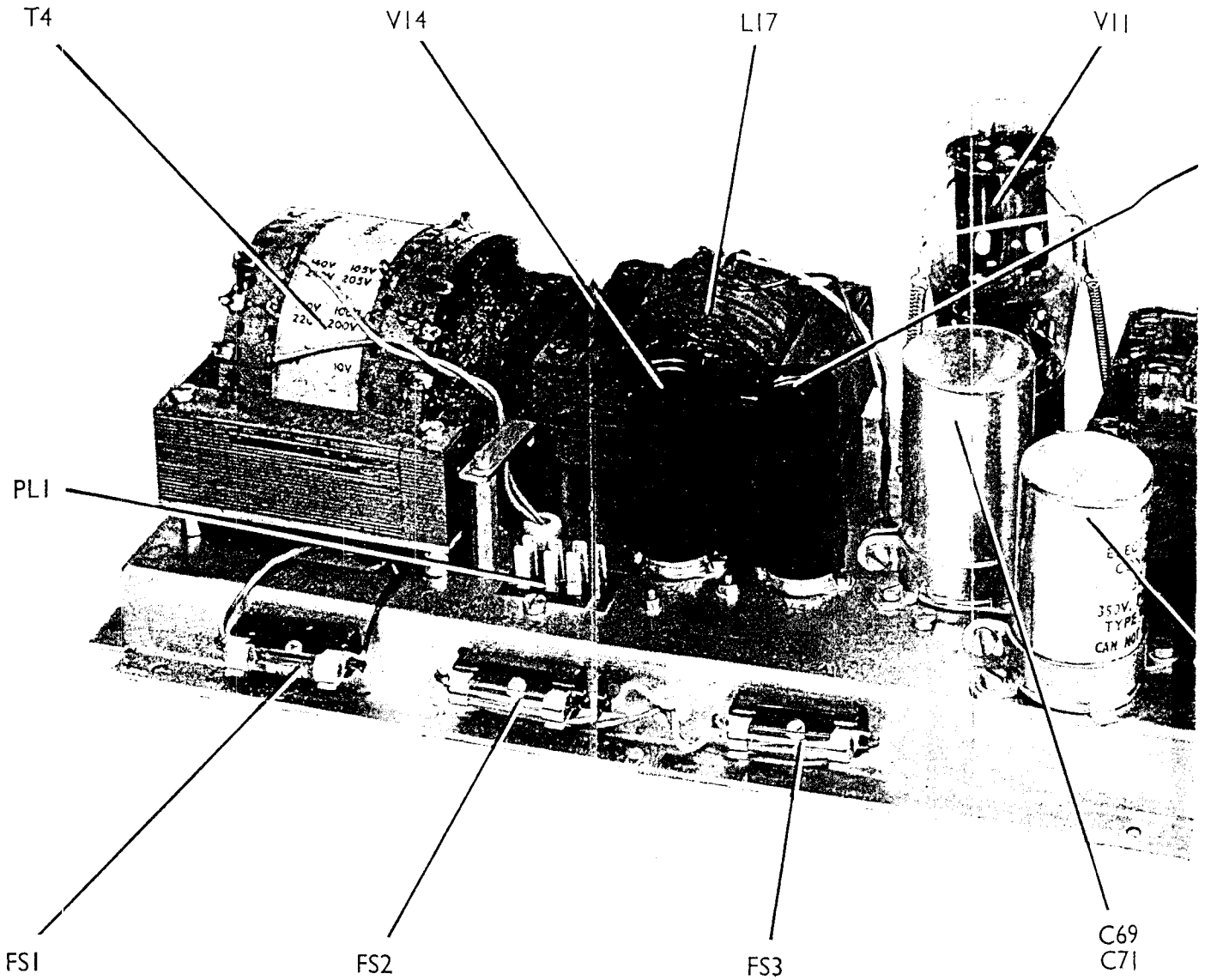

For Service Manuals Contact  
**MAURITRON TECHNICAL SERVICES**  
 8 Cherry Tree Rd, Chinnor  
 Oxon OX9 4QY  
 Tel:- 01844-351894 Fax:- 01344-352554  
 Email:- enquiries@mauritron.co.uk

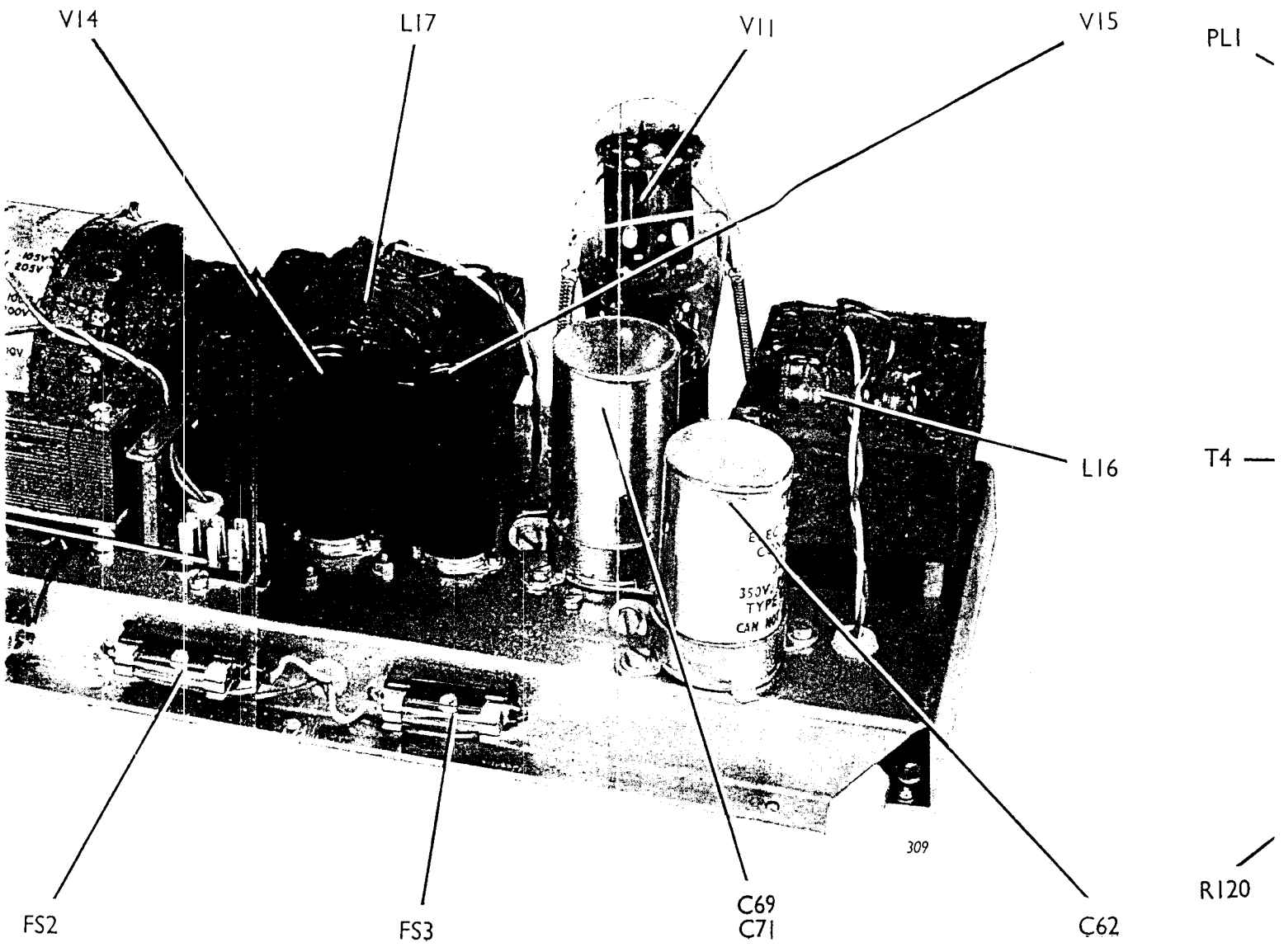

POWER UP

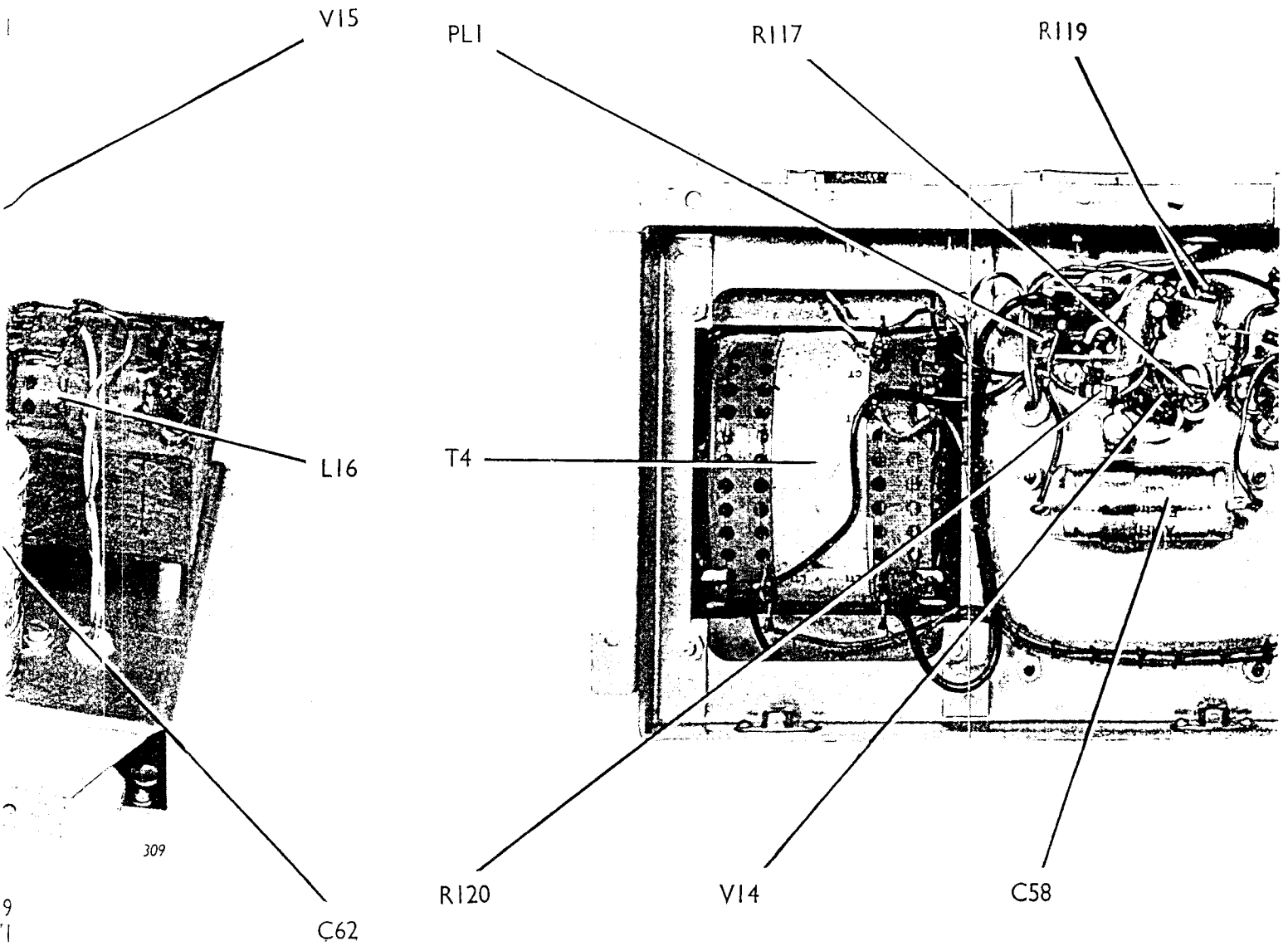

POWER UNIT

NOTE—C69 and C71 are now separate compo  
and are both mounted below the chas:

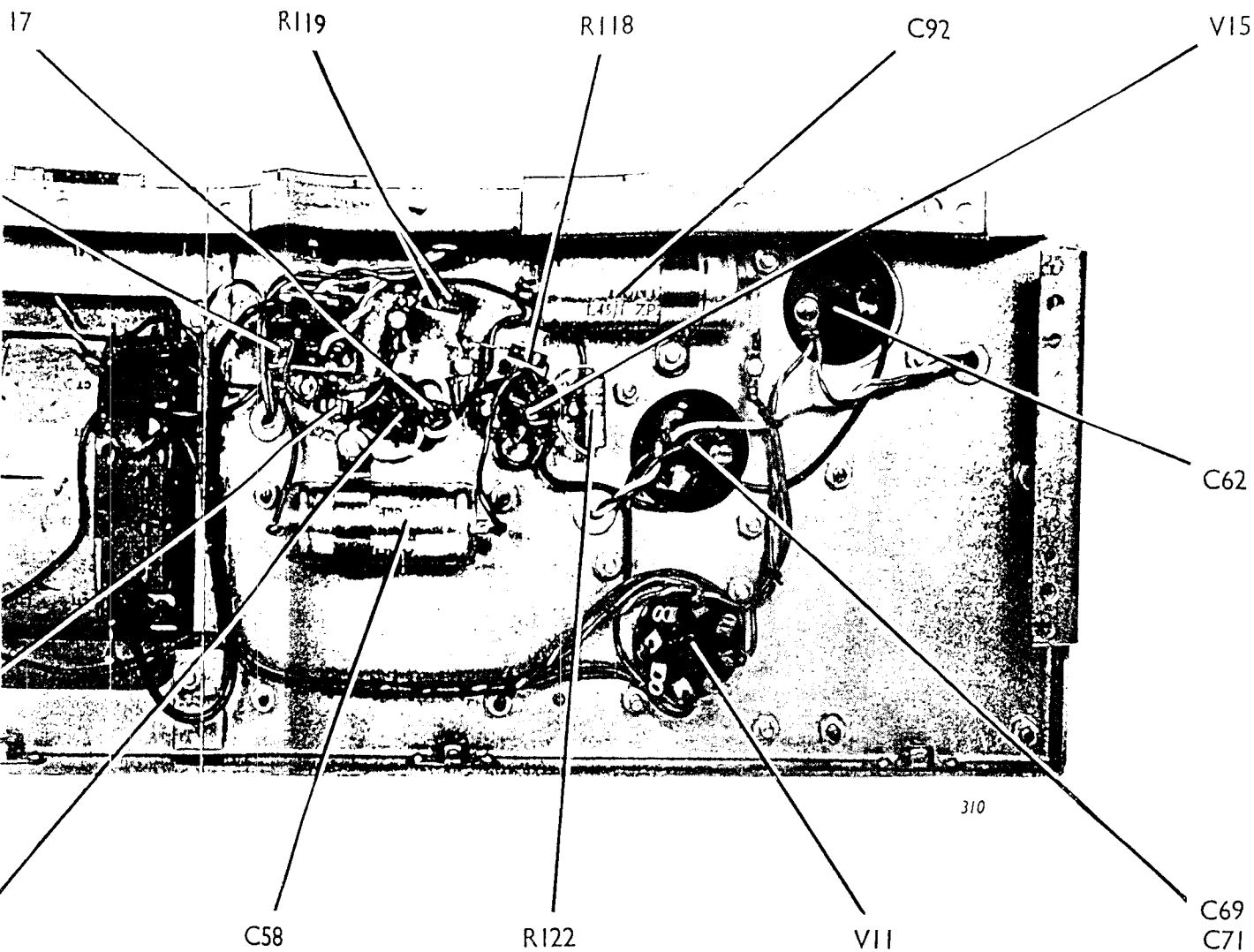

NOTE—C69 and C71 are now separate components  
and are both mounted below the chassis.

Fig. 6.7

# Section 8 Circuit diagrams

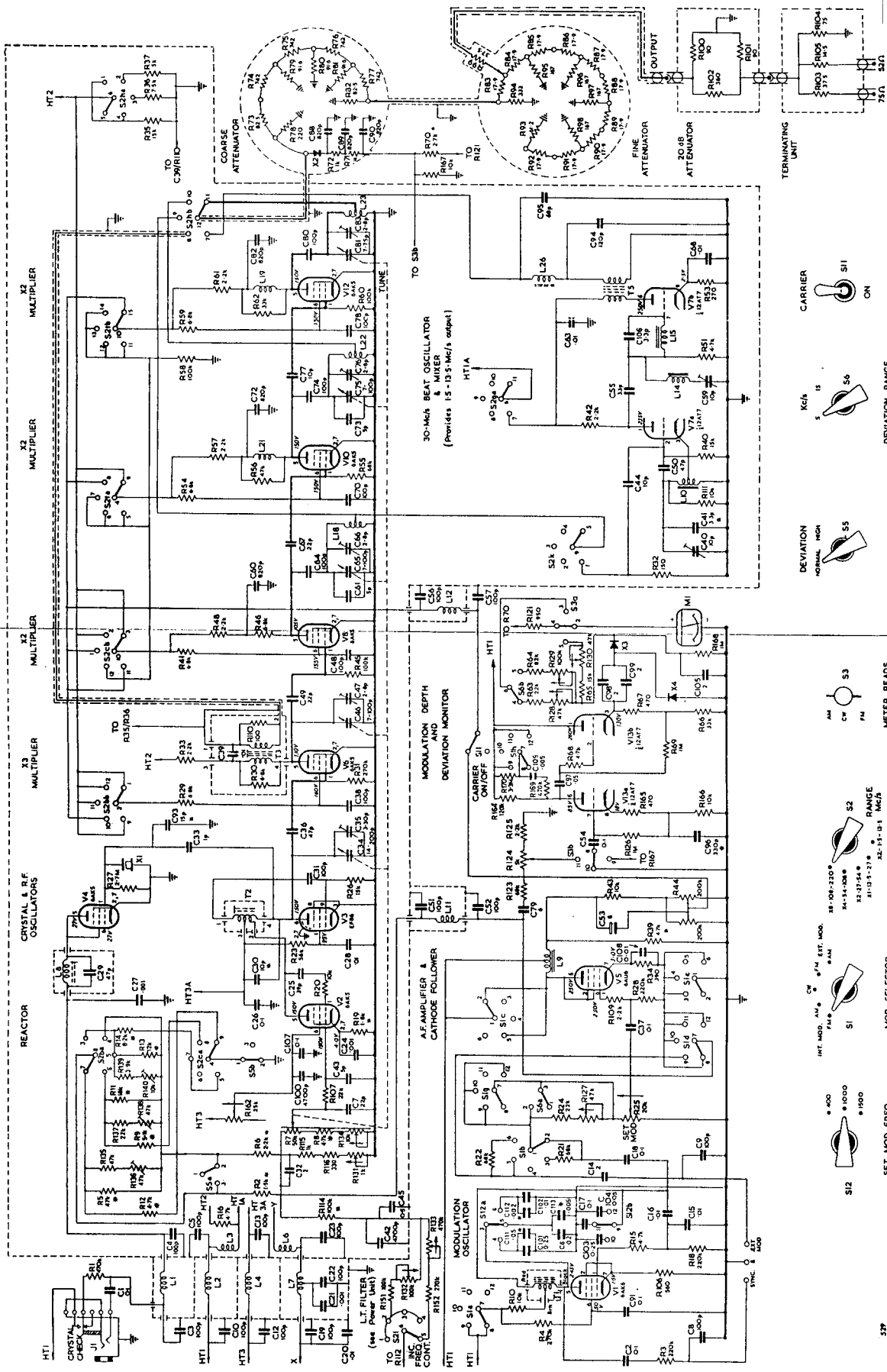

57

- NOTES**
- 1. COMPONENT VALUES**  
 Resistors: No suffix = ohms, k = kilohms, M = megohms.  
 Capacitors: No suffix = pF, u = microfarads.  
 \* Value selected during factory testing, nominal value shown.
- 2. VOLTAGES (in italics)**  
 Measured relative to earth unless otherwise stated.

S12 SET MOD. FREQ.  S11 HT. MOD. AM.  S2 RANGE  S3 METER READS  
 S5 DEVIATION NORMAL HIGH  S6 DEVIATION RANGE  S11 CARRIER ON

Fig. 8.1

R.F. AND L.F. UNITS

For Service Manuals Contact  
**MAURITRON TECHNICAL SERVICES**  
 8 Cherry Tree Rd, Chinnor  
 Oxon OX9 4CY  
 Tel: 01844-351694 Fax: 01844-352554  
 Email: enquiries@mauritron.co.uk

QM 895A/5  
 IC-248  
 EX TD23080/5 15.31

