



V.H.F. SIGNAL GENERATOR

TYPE TF 1064/B5

DFM ✓

OPERATING INSTRUCTIONS

for

V. H. F. SIGNAL GENERATOR

TYPE TF 1064B/5

CONTENTS

		Page
1	GENERAL INFORMATION	1
1.1	Introduction	1
1.2	Data Summary	1
1.3	Accessories Available	4
2	OPERATION	6
2.1	Installation	6
2.2	Switching On	6
2.3	Connectors	6
2.4	Tuning	7
2.5	C. W. Outputs	8
2.6	F. M. Outputs	9
2.7	A. M. Outputs	10
2.8	Special R. F. Output Conditions - Use of Accessories	10
2.9	A. F. Outputs	13
2.10	I. F. Outputs	14
3	TECHNICAL DESCRIPTION	16
3.1	R. F. Generator	16
3.2	F. M. & Incremental Frequency Control ...	16
3.3	Carrier Level Monitor	18
3.4	Output Attenuator	18
3.5	Amplitude Modulation	19
3.6	I. F. Oscillator	20
3.7	A. F. Oscillator	20
3.8	Power Unit	21
4	MAINTENANCE	22
4.1	Removal of Case - Access to Components .	22
4.2	Mains Input Arrangements	23
4.3	Replacement of Valves, Semiconductors and Crystals	24
4.4	Working Voltages	25

CONTENTS (continued)

DRAWINGS	<u>Dwg. No.</u>
Mains Input Connections	TLC 28392
Block Schematic Diagram	XD 29930/5
Circuit Diagram & Component Lists	XD 36576

GENERAL INFORMATION

1.1 INTRODUCTION

The V. H. F. Signal Generator Type TF 1064B/5 is one of a series of composite r. f., i. f. and a. f. signal sources covering the mobile radio bands. Although it forms a self-contained unit it is designed as a companion instrument to the Transmitter and Receiver Output Test Set Type TF 1065 (Series). Together, Signal Generator and Test Set provide comprehensive facilities for testing f. m. and a. m. mobile transmitter/receiver equipment, their compactness and portability making them particularly suitable for field use. Receiver sensitivity and image rejection, bandwidth and i. f. alignment, signal-to-noise ratio and quieting, discriminator linearity and symmetry, are examples of tests that can be made using the Signal Generator in conjunction with the TF 1065 or other suitable output indicator.

1.2 DATA SUMMARY

R. F. SIGNAL

Frequency

Ranges: (A) 68 - 108 Mc/s
(B) 118 - 185 Mc/s
(C) 450 - 470 Mc/s

Calibration Accuracy : 0.5%.

Frequency Stability : The generator is designed for use with narrow-band receivers and has good short-term stability.

Attenuator Reaction : Negligible over the calibrated output range.

Incremental Frequency Control : ±25 kc/s on Range A
±50 kc/s on Range B
±100 kc/s on Range C

1.2 (continued)

R. F. SIGNAL (continued)

Incremental Accuracy : Within $\pm 20\%$ of reading or $\pm 2\%$ of full scale, whichever is the greater.

Spurious Signals : There are no sub-harmonics at carrier frequencies between 68 and 185 Mc/s; on the highest range the $f/3$ sub-harmonic is approximately 15 dB down.

Output

Output Level : 0.5 μ V to 10 mV source e. m. f., continuously variable. The attenuator dial shows directly, and in decibels relative to 1 μ V, (a) source e. m. f. and (b) volts across a 50 Ω load. Uncalibrated higher outputs of at least 200 mV (100 mV across 50 Ω) are also obtainable.

Output Accuracy : 2 dB.

Source Impedance : Nominally 50 Ω .

V. S. W. R. : Better than 2.0.
Using 20-dB Pad Tm 5573, v. s. w. r. is better than 1.15.

Stray Radiation : Permits full use of lowest output.

Modulation (on r. f. signal only)

Internal 1,000 c/s F. M. :	Fixed deviations, 3.5 and 10 kc/s.
Deviation Accuracy :	In general, better than 10% for fixed deviation and 10% of full-scale for variable deviation.
Spurious A. M. on F. M. :	Typically less than 1% modulation depth at maximum deviation.
Internal 1,000 c/s A. M. :	Nominally 30% fixed depth on Ranges A and B. Modulation depth not specified on Range C.
Residual F. M. :	Deviation due to a. m. is typically less than 100 c/s at levels below 3 mV. Additional deviation due to hum, noise and microphony is typically less than 0.0001% of carrier frequency or 100 c/s, whichever is the greater, in a quiet location.

I. F. SIGNAL

Crystal Frequencies:	The i. f. crystal oscillator will function at any frequency between 290 kc/s and 16 Mc/s. Five switch-selected sockets are provided for crystals. Crystals are not supplied, but may be ordered separately - see Accessories Available.
Frequency Accuracy :	Crystal tolerance : 0.01% when working into a 30 pF circuit. Each crystal can be adjusted to higher accuracy by associated trimmer.

1.2 (continued)

L. F. SIGNAL (continued)

Output Level: Greater than 100 mV across a 1 k Ω load.

Modulation: The crystal oscillator can be amplitude modulated by internal 1,000 c/s source for signal identification.

A. F. SIGNAL

Frequency: 1,000 c/s.

Output Level: 0 to approx. 1.25 V e.m.f. continuously variable.

Power Supply: 200 to 250 V and 100 to 150 V, 40 to 100 c/s; 30 W.

Dimensions & Weight:

Height	Width	Depth	Weight
8½ in	12 in	8½ in	23 lb
(21.5 cm)	(31 cm)	(21.5 cm)	(10.4 kg)

1.3 ACCESSORIES AVAILABLE

L.F. Oscillator Crystals: Glass envelope, B7G-based Marconi Type QO 1655 Series; frequencies as specified between 290 kc/s and 16 Mc/s, subject to availability.

Output Lead Type TM 4969; comprises a 50 Ω coaxial cable, 42 inches long and terminated at both ends with BNC plugs.

50 to 75 Ω Matching Unit Type TM 5569; for use when testing 75 Ω apparatus. This series unit, inserted between the Signal Generator and the load, converts the output impedance of the Generator to 75 Ω . Fitted with a Type BNC input socket and a Belling-Lee coaxial input plug.

A. F. Monitor and Attenuator Type TM 5567; consists basically of a calibrated rectifier-type a. c. voltmeter shunted by a fixed-ratio 10:1 potentiometer. In addition to the two input terminals there are three output terminals. By connection to the appropriate output terminals, either the full voltage shown on the meter, or one-tenth of the voltage, can be obtained. In the latter case, the source impedance is approximately 900 Ω , and the output should be loaded with not less than 18 k Ω if the reading accuracy is to be maintained.

1.3 (continued)

I.F. Level Control, Type TM 5570; for use when a reduced i. f. output is required, this accessory consists of a variable potentiometer mounted in a metal case. The unit is fitted with a Type BNC plug and socket to facilitate its insertion between the Signal Generator and the apparatus under test.

20 dB Pad, Type TM 5573; this is a single π network housed in a small metal cylinder, with a Type BNC plug at one end and a Type BNC socket at the other end. In addition to providing 20 dB of attenuation, this pad improves the output v. s. w. r. of the Signal Generator.

6 dB Pad, Type TM 5573/1; this is also a single π network, and as with the 20 dB pad above, is fitted with a Type BNC plug at one end and a Type BNC socket at the other. This pad also improves the output v. s. w. r. although not to the same degree as the 20 dB Pad.

2

OPERATION

2.1 INSTALLATION

V. H. F. Signal Generator Type TF 1064B/5 can be adjusted to allow operation from any 40 c/s to 100 c/s power supply in the voltage ranges 100 to 150 V and 200 to 250 V.

Full instructions for adjusting the internal power unit to suit the local supply are given in Section 4. 2. MAINS INPUT ARRANGEMENTS.

Unless otherwise specified, the Signal Generator is normally despatched ready for immediate operation from 240 V supplies.

2.2 SWITCHING ON

BEFORE SWITCHING ON, be sure that the instrument is correctly adjusted to suit the particular mains supply to which it is to be connected; then proceed as follows :-

- (1) Check that the mechanical zero of the meter is correctly set.
- (2) Make connection to a suitable supply socket by means of the mains lead provided.
- (3) Turn the SUPPLY switch ON and note that the pilot lamp glows. The SUPPLY switch is located on the rear panel of the instrument.
- (4) Before proceeding further, allow ten or fifteen minutes to elapse for the internal circuits to warm up; if a particularly high order of stability is required, this time should be extended to, say, one hour.

2.3 CONNECTORS

The R. F. and I. F. panel outlets are both 50 Ω type BNC sockets. Connection to these outlets can be made by means of the two plugs supplied with the instrument: these are 50 Ω type BNC plugs, Transradio Ltd. (Gt. Britain) Code No. BN1/5, U. S. Military No. UG-88/U. A recommended cable for use with these plugs is U. S. Type RG-58A/U.

2.4 TUNING THE INSTRUMENT

The r.f. generator tuning ranges are as follows :-

Range A :	68 to 108 Mc/s
Range B :	118 to 185 Mc/s
Range C :	450 to 470 Mc/s

To obtain the required output frequency :-

- (1) Select the appropriate frequency range by means of the three-position RANGE switch. NOTE : after a range change a frequency restabilizing period of 10 to 15 minutes is recommended where high stability is required.
- (2) Set the incremental frequency dial to zero. The calibration of the main frequency dial is correct only when the incremental frequency dial is in this position.
- (3) Rotate the main frequency dial until the desired frequency marker on the scale corresponds with the cursor hair-line.

2.4.1 Using the Incremental Frequency Control

This control may be used to make accurately known carrier frequency changes within the following limits :-

<u>Available Coverage</u>	<u>Graduation Interval</u>
Range A: ± 25 kc/s	2.5 kc/s
Range B: ± 50 kc/s	5 kc/s
Range C: ± 100 kc/s	10 kc/s

The instrument should be tuned as described in Section 2.4, after which the incremental frequency control may be rotated to make increments or decrements in the output frequency, as required.

In order to obtain maximum accuracy of incremental tuning, it is recommended that the procedure detailed below should be adopted; this nullifies slight frequency inaccuracies due to hysteresis effects in the ferrite core of the reactor T3.

2.4.1 (continued)

- (1) Before setting the incremental dial to the required point, turn the dial to maximum deviation from zero, on the appropriate side ('+' or '-') of the zero line.
- (2) Turn the dial back to the zero line.
- (3) Retune - by means of the main frequency control - to the centre frequency of the equipment under test.
- (4) Now turn the dial from the zero point to the desired incremental point on the appropriate side ('+' or '-') as in (1).

For further increments or decrements away from zero, simply turn the dial to consecutive points. For decrements or increments back towards zero from a previously-set incremental point, the complete procedure described in (1) to (4) above should be carried out.

2.5 SETTING UP FOR C. W. OUTPUT

To use the r. f. generator with an unmodulated output :-

- (1) Set the CARRIER switch to C. W.
- (2) Tune to the desired radio frequency in the manner described in Section 2.4.
- (3) Adjust the SET CARRIER control to bring the pointer of the CARRIER LEVEL meter exactly to the reference mark - at approximately two thirds of full-scale.

Note: The carrier level should be readjusted whenever the pointer deviates from the reference mark.

- (4) Adjust the r. f. output to the desired level by means of the calibrated attenuator control.

2.5 (continued)

The attenuator dial has two scales, one calibrated directly in voltage units and the other in decibels relative to $1 \mu\text{V}$. The associated cursor is engraved with two hair-lines marked O/C and LOADED respectively. When using the line marked O/C the instrument can be regarded as a zero-impedance voltage source, generating the e.m.f. indicated on the attenuator dial, in series with a 50Ω resistor. The line marked LOADED is for use only when the instrument is working into a matched (50Ω) load; in this condition the line indicates the actual p. d. developed across the matched load.

The attenuator is calibrated up to 10 mV, but greater output can be obtained by adjusting the dial over the blank section above 10 mV. When full output (approximately 200 mV) is required, turn the attenuator and the SET CARRIER control to maximum output. Under these conditions the meter indication should be ignored.

NOTE: It is recommended that, where possible, the higher output levels should not be used over long periods, in order to ensure maximum oscillator valve life.

When the r. f. section of the instrument is switched to C. W., the h. t. supply to the a. f. oscillator may be switched OFF by means of the A. F. OSC. switch.

2.6 SETTING UP FOR F. M. OUTPUT

Internal 1-kc/s frequency modulation is available on all the r. f. ranges. Fixed deviations of either 3.5 kc/s or 10 kc/s may be obtained by means of the CARRIER switch.

To set up the instrument for F. M. operation :-

- (1) Set the CARRIER switch to F. M. 1 for 3.5 kc/s deviation, or to F. M. 2 for 10 kc/s deviation.
- (2) Tune to the desired carrier frequency in the manner described in Section 2.4.

2.6 (continued)

- (3) Switch the front-panel A. F. OSC. switch to ON.
- (4) Adjust the SET CARRIER control to bring the pointer of the CARRIER LEVEL meter exactly to the reference mark - at approximately two thirds of full-scale.
- (5) By means of the attenuator control, adjust the output voltage in the manner previously described (see Section 2.5).

Notes : (i) The carrier level should be readjusted whenever the pointer deviates from the reference mark.

(ii) For highest f. m. accuracy on the 450-470 Mc/s range the INC. FREQ. control should be set to zero.

2.7 SETTING UP FOR A. M. OUTPUT

Internal 1 kc/s amplitude modulation at a fixed depth of nominally 30% may be applied to all the r. f. ranges as follows :-

- (1) Set the CARRIER switch to A. M.
- (2) Tune to the required carrier frequency in the manner described in Section 2.4.
- (3) Switch the front-panel A. F. OSC. switch to ON.
- (4) Adjust the SET CARRIER control to bring the pointer of the CARRIER LEVEL meter exactly to the reference mark.

Note : The carrier level should be readjusted whenever the pointer deviates from the reference mark.

- (5) By means of the attenuator control, adjust the output voltage in the manner previously described (see Section 2.5).

2.8 SPECIAL R. F. OUTPUT CONDITIONS - USE OF OPTIONAL ACCESSORIES

The accessories mentioned in this section are described in Section 1.

2.8.1 Voltage Developed across Non-Matching Load

The nominal source impedance of the r. f. generator is 50 Ω. Assuming that the connecting lead to the equipment under test has a characteristic impedance of 50 Ω, the source impedance at the output end of the lead can also be regarded as 50 Ω.

When the load formed by the equipment under test is 50 Ω (resistive), the voltage developed across it is indicated under the LOADED line of the attenuator cursor. If, however, the load has an impedance other than 50 Ω, recourse must be made to the general expression

$$\text{voltage across load} = \frac{E_S \times Z_L}{Z_S + Z_L}$$

where E_S is the source e. m. f., i. e., open-circuit voltage, indicated by the attenuator,

Z_L is the load impedance, which may consist of resistive and reactive components.

Z_S is the source impedance - in this case 50 Ω resistance.

In particular, if the load is predominantly resistive and has a value R_L , then

$$\text{voltage across load} = \frac{E_S \times R_L}{50 + R_L}$$

2.8.2 Increasing the Source Impedance

If it is necessary to present the equipment under test with a source resistance of more than 50 Ω, the source resistance of the r. f. generator can be increased to the required value R_R by connecting a single resistor R_A in series between the output lead and the equipment under test. The value of the resistor which must be added is

$$R_A = R_R - 50 \Omega$$

2.8.2 (continued)

When a load R_L is connected to this arrangement

$$\text{voltage across load} = \frac{E_S \times R_L}{50 + R_A + R_L}$$

where E_S is the source e.m.f. indicated by the attenuator at the line marked C/C.

If it is required to raise the source impedance to 75Ω , the 50 to 75Ω Matching Unit Type TM 5569 enables the above modification to be made easily and in a manner suitable for v.h.f. conditions.

2.8.3 Reducing the Source Impedance

If it is necessary to present the equipment under test with a source resistance of less than 50Ω , then the output resistance of the r.f. generator can be made equal to the required value R_R by shunting the output cable, at the load end, with a resistor R_B , where

$$R_B = \frac{50 \times R_R}{50 - R_R} \quad \Omega$$

Under these conditions, the effective source e.m.f., i.e. open-circuit voltage, is

$$E_{\text{eff.}} = \frac{E_S \times R_B}{50 + R_B}$$

where E_S is the source e.m.f. indicated by the attenuator at the line marked O/C.

When a load R_L is connected to this arrangement

$$\text{voltage across load} = \frac{E_{\text{eff.}} \times R_L}{R_R + R_L}$$

2.8.4 Use of External Attenuator Pads

A separate $50\ \Omega$ fixed attenuator may be fitted between the output lead of the r.f. generator and an equipment under test in order to extend the lower end of the output range, or to ensure that the load is fed from a source which is known to be $50\ \Omega$ (resistive) to a high degree of accuracy. The 20 dB Pad Type TM 5573 and the 6 dB Pad Type TM 5573/1 may be employed for these purposes.

By using the 20 dB Pad, the calibrated voltage range of the r.f. generator is modified so that it is $0.05\ \mu\text{V}$ to 1 mV. This method of obtaining very low levels has the advantage that stray signals picked up by the connecting lead are attenuated by the pad before reaching the equipment under test.

The source impedance of the r.f. generator is nominally $50\ \Omega$, but some departure from this value may occur, particularly at the load end of the output cable. By adding one of the Pads at the load end, you can ensure that the equipment under test is fed from a source impedance very close to $50\ \Omega$. The 20-dB Pad is the more effective for this purpose, but the 6 dB Pad may be preferred since it imposes less attenuation. When either of these Pads is used, remember that the e.m.f. read from the attenuator on the V.H.F. Signal Generator must be divided by a factor of 10 or 2, as appropriate, when determining the e.m.f. applied to the load.

2.9 A.F. OUTPUT

In addition to providing a modulating signal for the r.f. and i.f. oscillators, the a.f. oscillator delivers a separate 1 kc/s output to the panel terminals marked A.F. and E. The open-circuit output voltage is continuously variable up to approximately 1.25 V by means of the A.F. OUTPUT control. The source impedance is less than $100\ \Omega$ at maximum output and diminishes to zero as the A.F. OUTPUT is reduced.

When the a.f. oscillator is being used alone, the r.f. and i.f. sections may be made inoperative by turning both the I.F. CRYSTAL and CARRIER switches to OFF.

2.10 I.F. OUTPUT

A fixed crystal-controlled output is available at the I.F. socket on the front panel. The frequency is determined by the I.F. CRYSTAL control, which has six positions. Any one of five crystals may be selected by this control, while in the extreme counter-clockwise position the i.f. oscillator is switched off.

2.10.1 Oscillator Crystals

Crystals are not automatically supplied with the instrument, but are available to special order, as detailed in Section 1 - ACCESSORIES AVAILABLE.

When first setting up, note the frequencies of the five crystals fitted in the numbered sockets at the rear of the instrument; the socket numbers correspond to the engraved switch positions on the front panel. The crystal frequencies should be marked on the small plate fitted below the attenuator dial.

Each crystal frequency can be adjusted by means of the trimmer beside the holder. The range of adjustment is of the order of 50 parts in 10^6 (.005%).

The i.f. oscillator may be used alone, or in conjunction with the r.f. generator applied to the aerial inlet of a receiver under test. In the latter case, with the i.f. output loosely coupled to the i.f. amplifier of the receiver, when the r.f. generator is adjusted to the radio frequency to which the receiver is tuned, a beat note will be produced. Since the beat occurs when the r.f. signal causes a resultant i.f. which coincides with the crystal-controlled frequency of the i.f. oscillator, it serves as a reference point about which the resultant i.f. can be adjusted by means of the r.f. generator incremental control. The incremental control can then be used for plotting and adjusting the overall response of the receiver (usually determined by the i.f. circuits)

It will be appreciated that by using the method just described with a receiver having a crystal-controlled local oscillator, the r.f. generator is set to the receiver channel frequency with a degree of precision normally associated with exact crystal control; although the accuracy of the i.f. reference signal is that of the simple crystal oscillator in

2.10.1 (continued)

the instrument, in terms of frequency error it corresponds to a considerably greater degree of accuracy at the receiver r. f. input.

2.10.2 Amplitude Modulation of I. F. Output

With the A. F. OSC. switch set to ON the i. f. output is modulated at low level by a 1,000 c/s tone. The depth of modulation is unaffected by the setting of the A. F. OUTPUT control and this facility is intended for signal identification purposes only.

3

TECHNICAL DESCRIPTION

It is suggested that the following sections should be read in conjunction with the Block Schematic and Circuit Diagrams included at the end of this handbook.

3.1 R. F. GENERATOR

The design of the r. f. generator eliminates the necessity for r. f. contacts in the range-switching circuits. Independent oscillator stages are used for each of the three r. f. bands, and the final tuned circuits are all permanently coupled to a common piston attenuator which controls the output level. The appropriate frequency range is selected by switching the h. t. supply to the oscillators.

Signals in the two lower frequency ranges are obtained directly from separate Colpitts oscillators, each of these using one half of double triode V4. Frequency modulation of each oscillator is provided by a ferrite reactor T3 having separate r. f. windings tapped across the two oscillator tuning inductors L14 and L15.

The 450 to 470 Mc/s range employs a frequency-multiplier system. A 150 to 156.6 Mc/s oscillator, V2, using a double triode push-pull circuit drives an x3 multiplier V3, a common-cathode double-triode in a push-pull circuit. Its low-Q anode circuit, with fixed tuning, couples this stage to the piston attenuator. Frequency modulation of this oscillator is achieved by feeding the modulating voltage to variable-capacitance diode MR8.

Battery valves, with a mains-derived regulated d. c. filament supply, are used for all three oscillators in order to keep drift and spurious f. m. to a minimum.

3.2 FREQUENCY MODULATION & INCREMENTAL FREQUENCY CONTROL

Frequency modulation is applied internally from the 1,000 c/s a. f. oscillator, V5A.

3.2 (continued)

Lower Frequency Ranges

Internal f. m. and incremental tuning is accomplished by means of a ferrite reactor, T3. The oscillator coils, L15 and L14, of ranges A and B respectively are partially shunted by small inductors forming part of the reactor. These latter coils are wound on a common ferrite core. This core is included in the magnetic circuit of a modulation winding which magnetically biases the reactor core to a suitable part of its permeability characteristic; as a result the inductances of the r. f. coils vary in accordance with the instantaneous current in the modulation winding. A signal from the internal 1000 c/s oscillator and an adjustable direct current are simultaneously applied to the modulation winding. The direct current causes the biasing of the ferrite core, and also, by adjustment, provides the incremental frequency control; the applied a. f. signal produces the frequency modulation.

The deviation and incremental frequency range are held constant throughout both the lower frequency bands by the action of a variable correcting potentiometer, RV4, which is ganged to the main tuning capacitor. The levels of the a. f. modulating voltage and the d. c. applied to the potentiometer are determined on each range by switched series preset resistors, RV10 and RV11, while the load presented via the potentiometer is kept reasonably constant, for all positions of its slider, as a result of R29 at one end balancing R30, C35, and T3 at the other end. C35 is employed to compensate for the reactance of T3 at the modulation frequency of 1,000 c/s. Resistors R44 and R51, and preset potentiometers RV15 and RV14, which are virtually short circuited at 1,000 c/s by C46, provide means of independently setting up the sensitivity of the incremental control on each of the two frequency ranges.

The 1,000 c/s signal generated by the a. f. oscillator is developed across R6 and RV6 in series. The voltage appearing across RV6 is employed to generate 3.5 kc/s deviation when the CARRIER switch is set to F. M. 1, and the total voltage is employed to generate 10 kc/s deviation when the switch is at F. M. 2. The direct current for the incremental frequency control and biasing purposes is obtained, via R5, from potentiometer RV2 which is connected in series with R42 across the h. t. supply; R5 isolates the modulating signal from the d. c. source.

3.2 (continued)

450 to 470 Mc/s Range

Frequency modulation on this range is achieved by means of variable-capacitance diode MR8, which is inversely biased by a few volts d. c.

Application of the a. f. modulating voltage to the diode via C37, RV13 and R71 causes its capacitance - and hence the oscillator tuning - to vary at the audio frequency.

Incremental tuning is obtained by using another variable-capacitance diode, MR9, which is also inversely biased by a fixed d. c. voltage. The variable d. c. shift voltage from RV2 is applied to this diode by way of R46, RV12 and R68 causing a change in diode capacitance and hence in oscillator tuning.

3.3 CARRIER LEVEL MONITOR

The r. f. input to the piston attenuator is monitored by a crystal-diode voltmeter, which is inductively coupled by L16 to the launching coils. The voltmeter circuit comprises a silicon rectifier, MR4, feeding the meter via switched preset resistors RV16, RV17, and RV18. These resistors are set up to provide correct carrier-level indication on all ranges.

3.4 OUTPUT ATTENUATOR

The piston attenuator is of the mutual-inductance type, in which the output is controlled by varying the distance between a launching coil and the co-planar pick-up element mounted in a waveguide operated below its cut-off frequency.

The launching coil comprises one of the three anode-tuning inductors L13, L14, or L15, depending on the range in use. The design is such that, for any one range, the coupling between the launching and pick-up coils is substantially independent of frequency. A 47Ω resistor of non-helical construction, R11, is used as the attenuator pick-up element.

3.5 AMPLITUDE MODULATION

The r. f. output may be amplitude-modulated, at a fixed depth of approximately 30%, by a 1,000 c/s tone derived from the internal a. f. oscillator. The system employed is the same for all three r. f. ranges; it is basically an audio-modulated attenuator associated with the r. f. output pick-up element R11. The attenuator presents a constant source impedance to the r. f. load.

The attenuator arrangement has an L-type configuration, and includes two modulated elements. These consist of forward-biased germanium diodes. One diode, MR6, is in series with the output attenuator pick-up loop; the other, MR5, is connected across the output, and forms the shunt element of the attenuator. A 1,000 c/s modulating signal is applied to the two diodes in opposite phase, in addition to the d. c. forward bias. This varies their resistance about the mean value determined by the direct-current component, so that, when the 1,000 c/s signal is driving the series diode towards its high-resistance condition, the resistance of the shunt diode is being lowered - and vice versa.

Bias is obtained from the d. c. heater supply, and is applied to the cathode of MR5 via resistor R49. After passing through MR5 the bias current is applied to the cathode of MR6 via the low-resistance path offered by L12; here, the bias current is augmented, from the same source, via resistor R48 and the low-resistance winding of L18. The anode of MR6 is connected to earth, thus completing the d. c. circuit. As a result, MR6 is forward-biased to a greater degree than MR5. This arrangement is designed so that a source impedance of 50 Ω is obtained.

The 1,000 c/s modulating signal is applied to the circuit via C47. The reactance of C43 is so high at this frequency that the shunting effect of this component can be neglected. R12 is virtually short-circuited by the low reactance of L18, and the full modulating signal is thus applied across MR6. The anode of MR5 is connected to the cathode of MR6 via L12 which effectively short-circuits the pick-up loop R11. The cathode of MR5 is decoupled to chassis by C48. The two diodes are thus connected in reverse parallel so that they change their resistances in opposite directions (one increasing while the other decreases) under the influence of the modulating signal. R. F. load impedances are prevented from shunting MR5 by capacitor C49; this latter component offers a high impedance to the 1,000 c/s modulating signal, but has negligible reactance at radio frequencies.

3.5 (continued)

The modulation, achieved in the manner described, is adjusted to approximately 30% at the centre of each band by the use of preset resistors RV7, RV9, and RV8.

3.6 I. F. OSCILLATOR

The i. f. oscillator uses one section of double-triode V5 in a crystal-controlled circuit. A switch, SC, allows any one of a bank of five crystals to be brought into circuit. In the OFF position of the switch, the grid of V5 is returned to chassis so that the valve receives cathode bias from R32 - this bias is removed in the oscillating condition due to grid resistor R31 being returned to cathode. The crystal holders are accessible without removing the instrument from its case, and crystals of any frequency between 290 kc/s and 16 Mc/s can be plugged in. Trimmer capacitors C57 to C61 enable the frequency of each crystal to be independently adjusted. The output signal is available at a Type BNC coaxial socket on the front panel. The i. f. signal can be amplitude-modulated to a fixed depth by the internal a. f. oscillator, via C36 and R50, from the secondary winding on the a. f. oscillator transformer.

3.7 A. F. OSCILLATOR

The a. f. oscillator comprises a series-fed Hartley circuit, using the section B of double triode V5. In addition to providing a modulating signal for the r. f. and i. f. generator circuits, the output is fed to a pair of panel terminals via the potentiometer formed by R16 and the A. F. OUTPUT control RV3. The a. f. oscillator can be switched off by means of switch SE.

When the Signal Generator is being used in conjunction with the Transmitter and Receiver Output Test Set Type TF 1065 (Series), it is quite normal for the a. f. oscillator to be in use at the same time as the r. f. generator. The a. f. signal modulates the transmitter section of the apparatus under test, while the r. f. signal is fed to the crystal mixer inside the deviation monitor section of the Test Set. For this reason, the a. f. oscillator can remain functioning even when the r. f. signal generator is switched to C. W.

3.8 POWER UNIT

A self-contained power unit is mounted on the rear panel of the instrument; interconnection between the power unit and the generator chassis is by means of an International Octal plug and socket, PL2 and SKT1.

A full-wave bridge rectifier, MR1, is used in conjunction with components C3, C4, and R52 to provide the d. c. supply for the filaments of valves V2, V3, and V4 in the generator unit. The l. t. voltage is held constant by means of transistor VT1 connected as a series regulator; a Zener diode, MR7, provides the reference voltage for the transistor.

A second l. t. winding on the transformer provides an unregulated 6.3 V supply for the filament of valve V5 and for the pilot lamp PLP1.

H. T. is derived from a 160 V winding feeding metal rectifiers MR2 and MR3 in a voltage doubler circuit employing capacitors C1 and C53. Conventional series-regulation of the h. t. supply is provided by valves V1, V6 and V7.

The mains transformer, T1, has a double-wound primary, the two tapped sections of which can be connected in series or parallel to allow operation from a selection of supply voltages in the ranges 100 to 150 and 200 to 250 V.

The mains supply is switched by means of a double-pole switch SA, and both input lines are fitted with 0.5 A cartridge fuses.

4

MAINTENANCE

4.1 REMOVAL OF CASE - ACCESS TO COMPONENTS

Removing the Case

The instrument case is constructed from three parts : a front panel with its surround, carrying the main chassis and controls; a rear panel with its surround, on which the power unit is mounted; and a one-piece formed aluminium centre-section. Separating these parts involves the following procedure :-

- (1) Place the instrument on its face, knobs downwards.
- (2) Remove the two 2 BA coin-screws securing the rear panel and lift the latter, complete with the power unit, clear of the case. One screw is located immediately to the right of the SUPPLY ON/OFF switch, the other being at the top left-hand side, next to the i. f. crystal sockets.
- (3) Separate the internal Octal plug and socket connecting the power unit to the main chassis.
- (4) The rear panel may now be set aside and the sheet-metal centre section removed from the generator.

Obtaining Access to the Power Unit Components

The components of the power unit are mounted on a small chassis attached to the rear panel. The 'top' of this chassis faces towards the front panel and, in order to obtain access to components mounted 'below chassis', it is necessary to separate the power unit from the rear panel. The procedure for doing so is as follows :-

- (1) Unsolder the wires leading from the power unit to the two fuse-holders.
- (2) Remove the four 4 BA instrument-headed screws arranged in a vertical line at the left of the fuse-holders and mains ON/OFF switch.

4.1 (continued)

- (3) With the rear panel flat on the bench, transformer and chokes uppermost, remove the four 6 BA nuts and two 6 BA screws securing the remaining edge of the power unit. The unit may now be lifted off the panel. (The four screws from which the nuts are removed are held captive beneath the panel surround; if difficulty is experienced when replacing the power unit, due to these screws turning, remove the surround to expose the screw heads.)

Obtaining Access to the R. F. Unit Components

The periphery of the r. f. screening cover is attached to the r. f. unit by means of 6 BA cheese-headed screws; these should be removed in order to release the cover, taking care not to lose the washers beneath the screw heads. When replacing the cover, it is important that all the screws should be replaced and fully tightened.

4.2 MAINS INPUT ARRANGEMENTS

The mains transformer has a double-wound primary with arrangements for connection of the two tapped sections in series for the 200 to 250 V range, or in parallel for the 100 to 150 V range. The instrument is normally despatched with its power unit set for operation from a 240 V mains supply. It can be adjusted for operation from other supplies at mains frequencies between 40 and 100 c/s by following the instructions given below.

The arrangements of the connections to the input of the mains transformer are shown diagrammatically on Drawing No. TLC 28392.

The input voltage tappings are made by means of soldered connections to tags mounted on the transformer winding. The tags are accessible through the aperture in the rear panel, after removal of the transparent cover plate.

The two sections of the double-wound primary are connected together by linking the appropriate tags as in 'A' on the diagram. To change from one major voltage range to another, alter the linking on the transformer as shown.

4.2 (continued)

Selection of intermediate voltages within the range is made by means of fly-leads on the transformer tags. These tags are common to both ranges, and are therefore each marked with two voltages; the applicable voltage depends on the position of the major range links. One fly-lead must always be connected to either the '0' or '+10' tag; the other is connected to the tag whose voltage, added to 0 or 10 as appropriate, equals the mains supply voltage. For example, for a 240 V supply, connect the fly-leads to the '0' and '240' respectively; for a 210 V supply, connect the fly-leads to the '+10' and '200' respectively. Do not connect either fly-lead to the tags marked TAP A or TAP B.

4.3 REPLACEMENT OF VALVES, SEMICONDUCTORS & CRYSTALS

The three r. f. valves (V2, V3, and V4) are mounted horizontally on the side of the r. f. unit - V3 is located immediately beside the piston attenuator while V2 and V4 are separated from it by the spindle of the incremental frequency control. Of the remaining valves, V1, V6, and V7 are located on the power unit chassis, and V5 is mounted horizontally under the main chassis next to the i. f. crystal sockets. The transistor VT1 is mounted on the side of the power unit chassis near the mains switch and fuses; it is secured to the chassis by means of two 6 BA screws in its collector flange. Connections to the transistor are soldered.

When replacing the transistor, the mica insulating gasket and insulating bushes on the collector flange must be used. The mica gasket should be lightly smeared with silicone grease before replacement; this ensures maximum conduction of heat from the transistor flange to the chassis.

Normally, all the valves may be replaced without special selection; it should be appreciated, however, that if the old and new valves possess significantly different parameters, then some change may occur in the performance of the associated circuits.

Semiconductors. To gain access to the silicon diode MR4, forming part of the CARRIER LEVEL meter circuit, the cover should be removed from the r. f. unit. MR4 is mounted in spring clips close to the mouth of the piston attenuator. Replacement of MR4 may affect the sensitivity of the meter circuit.

4.3 (continued)

It is most unlikely that the components which form part of the piston attenuator head assembly (including germanium diodes MR5 and MR6) will need to be replaced or adjusted. Replacement of any of these components would, however, necessitate the partial dismantling of the attenuator and subsequent major adjustments to the r.f. tuned circuits. It is, therefore, strongly recommended that an instrument with a piston attenuator suspected of being defective should be returned to Marconi Instruments Limited for servicing.

Crystals. The five plug-in i.f. oscillator crystals are accessible at the rear of the instrument; these can be inspected and, if necessary, replaced without removing the instrument from its case.

4.4 WORKING VOLTAGES

The following voltages were obtained from measurements on a typical TF 1064B/5; the voltmeter employed had an input impedance of 20 kΩ/V. Component and valve number codings refer to the Circuit Diagram supplied with this handbook.

Power Supplies

<u>Measurement</u>	<u>Connection</u>	<u>Reading</u>
LT1, LT3	Across transformer windings	6.3 V a.c.
LT2	Across transformer winding	14.5 V a.c.
A. C. H. T.	Across transformer winding	160 V a.c.
Unsmoothed l. t.	Across C3	-14 V d.c.
Smoothed l. t.	Across C4	-11.5 V d.c.
Stabilized l. t.	VT1 base and earth	-7.5 V d.c.
L. T. for V3	SKT1, pin 7 and earth	-6.3 V d.c.
L. T. for V2 and V4	SKT1, pin 8 and earth	-5.6 V d.c.
Unsmoothed h. t.	Across C1 and C53	320 V d.c.
H. T. supply to V6	Across C2	315 V d.c.
Stabilized h. t.	SKT1, pins 4 and 5 to earth	150 V d.c.*

* Set by means of RV5; this preset control is mounted on the side of the power unit chassis, near the mains switch and fuses.

4.4 (continued)

Valve Electrode Voltages

<u>Valve No.</u>	<u>Anode</u>	<u>Cathode</u>	<u>Conditions</u>
V1	320	150	
V2	75 (pin 2)	-	Range C
V2	75 (pin 6)	-	Range C
V3	120 (pin 1)	3 (pin 7)	Range C
V3	120 (pin 2)	-	Range C
V4	95 (pin 2)	-	Range B
V4	65 (pin 6)	-	Range A
V5	145 (pin 1)	4.5 (pin 3)	
V5	150 (pin 6)	7 to 13 depending on crystal	
V6	140	85	
V7	85	-	

CIR. REF.	DESCRIPTION	GRID	STOCK LIST REF.	CIR. REF.	DESCRIPTION	GRID	STOCK LIST REF.
	<u>RESISTORS</u>			R27	22KΩ ± 10% 1/10W	K4	146 TF 1064B/5
R1	2.2KΩ ± 10% 1/2W	C1	19 TM5262/3	R28	22KΩ ± 10% 1/10W	K3	146 TF 1064B/5
R2	470KΩ ± 10% 1/2W	D1	20 TM 5262/3	R29	3.3KΩ S.I.C. 1/10W	G5	147 TF 1064B/5
R3	10Ω ± 10% 1/2W	F2	124 TF1064B/5	R30	4.7KΩ ± 10% 1/10W	K5	148 TF 1064B/5
R4	7.5KΩ ± 5% 6W	G1	125TF1064B/5	R31	470KΩ ± 10% 1/2W	D4	136 TF 1064B/5
R5	6.8KΩ ± 10% 1/2W	F1	9 TM5071A/3	R32	1.2KΩ ± 10% 1/2W	D4	133 TF 1064B/5
R6	680Ω ± 10% 1/2W	F5	7 TM5071A/3	R33	(Part 220KΩ ± 10% 1/2W of L21	K2	309 TF 1064B/5
R7				R34	2.2KΩ ± 10% 1/2W SIC	K2	122 TF 1064B/5
R8				R35	10KΩ ± 10% 1/2W SIC	K2	131 TF 1064B/5
R9	47KΩ ± 10% 1/10W	H3	144TF1064B/5	R36	220Ω ± 10% 1/2W	L5	4 TM5071A/3
R10	47KΩ ± 10% 1/10W	H2	144TF1064B/5	R37			
R11	(Part 47Ω ± 10% 1/2W of L12)	L3	18A TM 5268	R38			
R12	(Part 150Ω ± 10% 1/2W of L18)	L3	19A TM 5268	R39			
R13	1.5KΩ ± 10% 1/10W	L4	5 TM 7098	R40	470Ω ± 10% 1/2W	L2	128TF1064B/5
R14	3.3KΩ ± 10% 1/10W	L4	6 TM 7098	R41	1.5KΩ ± 10% 1/10W	M5	5 TM7098
R15	680Ω ± 10% 1/2W	L5	5 TM5071A/3	R42	2.2KΩ ± 10% 1/2W	F1	137TF1064B/5
R16	150Ω S.I.C. 1/2W	F5	143TF1064B/5	R43	220Ω ± 10% 1/10W	L2	149TF1064B/5
R17	3.9K ± 10% 1/2W S.I.C.	F4	6 TM5071A/3	R44	10KΩ ± 10% 1/10W	J5	5 TM 7097
R18	100K ± 10% 1/2W	F4	8 TM5071A/3	R45	330KΩ ± 10% 1/2W	B5	142TF1064B/5
R19				R46	220KΩ ± 10% 1/10W	H1	7 TM 7098
R20	2.2KΩ ± 10% 1/2W	F4	122TF1064B/5	R47	1KΩ S.I.C. 1/2W	G6	12 TM5071A/3
R21	220KΩ ± 10% 1/2W	F5	134TF1064B/5	R48	3.3KΩ ± 10% 1/2W	M3	139TF1064B/5
R22	1.5KΩ ± 10% 1/2W	D5	126TF1064B/5	R49	4.7KΩ ± 10% 1/2W	M3	140TF1064B/5
R23	4.7KΩ ± 10% 1/2W	J3	141TF1064B/5	R50	1W S.I.C. 1/2W	D3	132TF1064B/5
R24	100KΩ ± 10% 1/10W	K3	145TF1064B/5	R51	22KΩ ± 10% 1/10W	J4	6 TM 7097
R25	100KΩ ± 10% 1/10W	K2	145TF1064B/5	R52	6.5Ω ± 10% 3.5W	G2	28 TM5262/3
R26	470Ω ± 10% 1/2W	K3	128TF1064B/5	R53	270KΩ ± 10% 1/2W	D2	24 TM5262/3

DRAWN D.J.W.	CHKD.	USED ON	COMPONENT LIST
DATE 4.6.62.	APPD.	TF 1064B/5	XD 36576
TRACED.		SHT. 1 OF 6 SHTS.	
MARCONI INSTRUMENTS LTD.			

CIR. REF.	DESCRIPTION	GRID	STOCK LIST REF.	CIR. REF.	DESCRIPTION	GRID	STOCK LIST REF.
C2	8 μ F ^{+50%} / _{-20%} 450V	C2	38 TM5262/3	C27	.01 μ F \pm 10% 400V	E5	8 TM 1296G
C3	1000 μ F ^{+50%} / _{-20%} 25V		42 TM5262/3	C28	.01 μ F \pm 20% 400V	E5	166TF1064B/5
C4	500 μ F ^{+100%} / _{-20%} 25V	C2	40 TM5262/3	C29	8 μ F ^{+50%} / _{-20%} 350V	E5	160TF1064B/5
C5	4700PF	K1	5 TM 5273	C30	.001 μ F \pm 20% 600V	K4	162TF1064B/5
C6	4700PF	K1	5 TM 5273	C31	.001 μ F \pm 20% 600V	K4	162TF1064B/5
C7	8 μ F ^{+50%} / _{-20%} 250V	K1	13 TM 7098	C32	820PF \pm 20% 500V	K1	279TF1064B/5
C8	4700PF	G3	5 TM 5273A	C33	22PF \pm 5%	K3	163TF1064B/5
C9	4700PF	G2	5 TM 5273A	C34	22PF \pm 5%	K4	163TF1064B/5
C10	4700PF	G2	5 TM 5273J	C35	0.1 μ F \pm 25% 150V	K5	313TF1064B/5
C11	4700PF	G2	5 TM 5273J	C36	.01 μ F \pm 20% 400V	E3	166TF1064B/5
C12	.5 μ F \pm 25% 150V	F5	10 TM5071A/3	C37	.01 μ F ^{+50%} / _{-20%} 100V	H4	14 TM 7098
C13	.001 μ F \pm 20% 600V	H2	162TF1064B/5	C38	.01 μ F ^{+50%} / _{-20%} 100V	L2	173TF1064B/5
C14	.001 μ F \pm 20% 600V	H3	162TF1064B/5	C39	220PF	D5	167TF1064B/5
C15	4700PF	L5	5 TM 5273C	C40	4700PF	L1	5 TM 5273A
C16	4700PF	L5	5 TM 5273C	C41	4700PF	L1	5 TM 5173A
C17	22PF \pm 5%	H3	163TF1064B/5	C42	4700PF 500V WKG.	L3	15 TM 5260
C18	22PF \pm 5%	H2	163TF1064B/5	C43	4700PF 500V WKG.	L3	15 TM 5268
C19	.001 μ F \pm 20% 600V	J3	162TF1064B/5	C44	220PF	D4	168TF1064B/5
C20	4700PF	G4	5 TM 5273C	C45	10PF \pm .5PF 750V	D4	171TF1064B/5
C21	4700PF	G4	5 TM 5273C	C46	1 μ F \pm 20% 150V WKG.	J5	170TF1064B/5
C22	18PF \pm 5%	K2	314TF1064B/5	C47	25 μ F ^{+100%} / _{-20%} 18V WKG	M3	169TF1064B/5
C23	18PF \pm 5%	K3	314TF1064B/5	C48	25 μ F ^{+100%} / _{-20%} 18V WKG.	M3	169TF1064B/5
C24A		K3		C49	.001 μ F \pm 20% 400V WKG 26364-302	L3	14 TM 5268
C24B	VAR. CAP. 3 GANG	L3	165TF1064B/5	C50	0.1 μ F ^{+80%} / _{-20%}	G5	14 TM 7097
C24C		L4		C51	8 μ F ^{+50%} / _{-20%} 450V	D2	38 TM5262/3
C25	4700PF	G1	5 TM 5273	C52	0.10 μ F \pm 20% 350V	D2	41 TM 5262/3
C26	4700PF	G1	5 TM 5273	C53	32 μ F ^{+50%} / _{-20%} 275V	C1	37 TM5262/3

DRAWN D. J. K.	CHKD.	USED ON TF 1064B/5	COMPONENT LIST X D. 36576
DATE 4.6.62.	APPD.	SHT. 3 OF 6 SHTS.	
TRACED.	MARCONI INSTRUMENTS LTD.		

CIR. REF.	DESCRIPTION	GRID	STOCK LIST REF.	CIR. REF.	DESCRIPTION	GRID	STOCK LIST REF.
C54	1.5PF ± 0.5PF	J3	276TF1064B/5	L14	COIL 118-185 MC/S	L4	302TF1064B/5
C55	2.2PF ± 0.5PF SIC 750V	H2	277TF1064B/5	L15	COIL 68-108 MC/S	L4	303TF1064B/5
C56	0.1µF +80% -20% 150V	H1	312TF1064B/5	L16	MONITOR COIL	L2	308TF1064B/5
C57	TRIMMER 2-11PF	C4	172TF1064B/5	L17	CHOKE 85µH	L1	1 TM 5273A
C58	TRIMMER 2-11PF	C4	172TF1064B/5	L18	COIL	L3	19 TM 5268
C59	TRIMMER 2-11PF	C5	172TF1064B/5				
C60	TRIMMER 2-11PF	C5	172TF1064B/5	L20	CHOKE	D4	119TF1064B/5
C61	TRIMMER 2-11PF	C5	172TF1064B/5	L21	CHOKE	K2	309TF1064B/5
C62	1µF ± 10% 150V	F4	174TF1064B/5				
C63	4700PF	G4	5 TM 5273J		VALVES		
C64	4700PF	G4	5 TM 5273J	V1	6AQ5	D1	58 TM5262/3
C65	2500µF -20% +100% 18V	D3		V2	DCC90	H3	224TF1064B/5
				V3	ECC91	K2	225TF1064B/5
	INDUCTORS.			V4	DCC90	K4	224TF1064B/5
L1				V5	12AT7	D +5	
L2	CHOKE 85µH	G4	11 TM 5273J	V6	6AK5	D1	59 TM5262/3
L3	CHOKE 85µH	K1	2 TM 5273	V7	85A2	C2	60 TM5262/3
L4	CHOKE 22µH	G3	2 TM 5273A				
L5	CHOKE 6µH	G2	2 TM 5273J				
L6	CHOKE 85µH	L5	2 TM 5273C				
L7	CHOKE 85µH	G5	1 TM 5273C		TRANSISTORS.		
L8	CHOKE 85µH	G1	1 TM 5273	VT1	MULLARD OC35	D2	56 TM 5262/3
L9	COIL 150-157 MC/S	J2	114TF1064B/5				
L10	CHOKE 12µH	J3	117TF1064B/5				
L11	BIFILAR CHOKE	G3	111TF 1064B/5		SWITCHES.		
L12	COIL	L3	18 TM 5268	SA	D.P.C.O.	B2	192TF1064B/5
L13	COIL 450-470 MC/S	L2	311TF1064B/5				

DRAWN D.J.W.	CHKD.	USED ON TF1064B/5	COMPONENT LIST XD36576
DATE 4.6.62.	APPD.	SHT. 4 OF 6 SHTS.	
TRACED.	MARCONI INSTRUMENTS LTD.		

2/2000/5 a

CIR. REF.	DESCRIPTION	GRID	STOCK LIST REF.	CIR. REF.	DESCRIPTION	GRID	STOCK LIST REF.
SBab		L5			Pilot Lamps.		
SBac		H5		PLPI	6.3V 0.15amp	B2	200TF1064B/5
SBBA	2 Sec 3 Posn	L1	104TF1064B/5				
SBbc		J5			Fuses.		
SBbb		J1		FS1	.5amp	B2	191TF1064B/5
SBca		K1		FS2	.5amp	B2	191TF1064B/5
SBca		J5					
SCa		D5			Plugs.		
SCc	2 Sec 6 Posn.	C4	52 TF1064B/5	PLI	3 Way	A2	1 TM 2560AU
SCd		C4		PL2	8 Way	A-2	181TF1064B/5
SDaa		B1					
SDab	2 Sec 5 Posn	F5	51TF 1064B/5				
SDca		M5					
SDcb		F4			Sockets.		
SE	D.P.C.O.	E4	192TF1064B/5	SKT1	8 Way	E 1-2	45 TM 5262/3
				SKT2	axial Single Pole co-	M3	11 TM 5268
				SKT3	axial Single Pole co-	M6	201TF1064B/5
Transformers							
T1	Mains Transformer	B1-2	1 TM5262/3		Rectifiers.		
T2	Tuned Transformer	E5	5 TF1064B/5	MR1		C3	51 TM5262/3
T3	Reactor	K5	4TF1064B/5	MR2	C2D	C1	52 TM5263/3
				MR3	C2D	C2	52 TM5262/3
				MR4	CS2A	A2	202TF1064B/5
METERS							
M1	100µA	M1	3 TF1064B/5	MR5	GEX 66 ^{HD 1870}		10 TM5268
				MR6	GEX 66 ^{HD 1870}	L3	10 TM5268

DRAWN D.J.W.	CHKD.	USED ON TF1064B/5.	COMPONENT LIST XD36576
DATE 4.6.62.	APPD.	SHT. 5 OF 6 SHTS.	
MARCONI INSTRUMENTS LTD.			

FIGURE 1

FOR
200-250 VOLTS
MAINS SUPPLIES

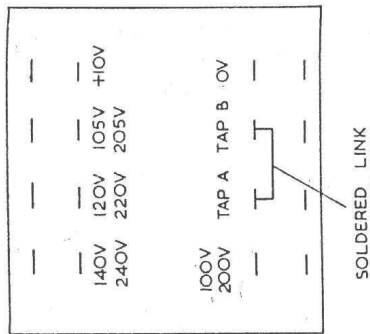

A ARRANGEMENT OF PRIMARY
SOLDER TAG CONNECTIONS
ON MAINS TRANSFORMER

B FLY LEAD CONNECTIONS

CONNECT THE FLY-LEADS TO GIVE
A COMBINATION TO SUIT MAINS VOLTAGE.
ONE FLY-LEAD MUST GO TO EITHER '+10' OR '0' TAP

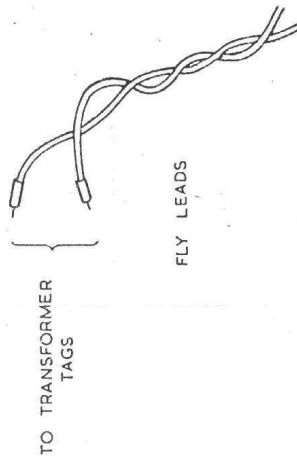
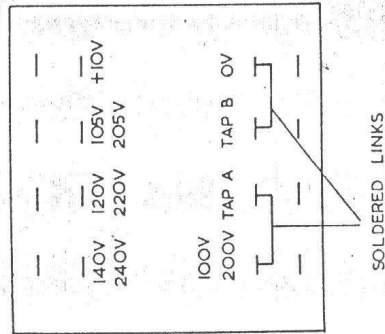
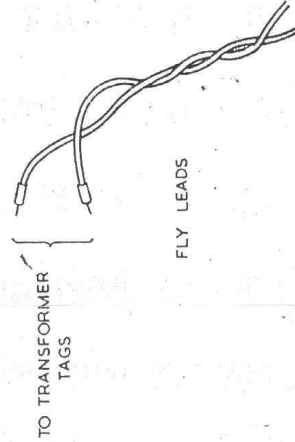

FIGURE 2

FOR
100-150 VOLTS
MAINS SUPPLIES



MAINS INPUT CONNECTIONS



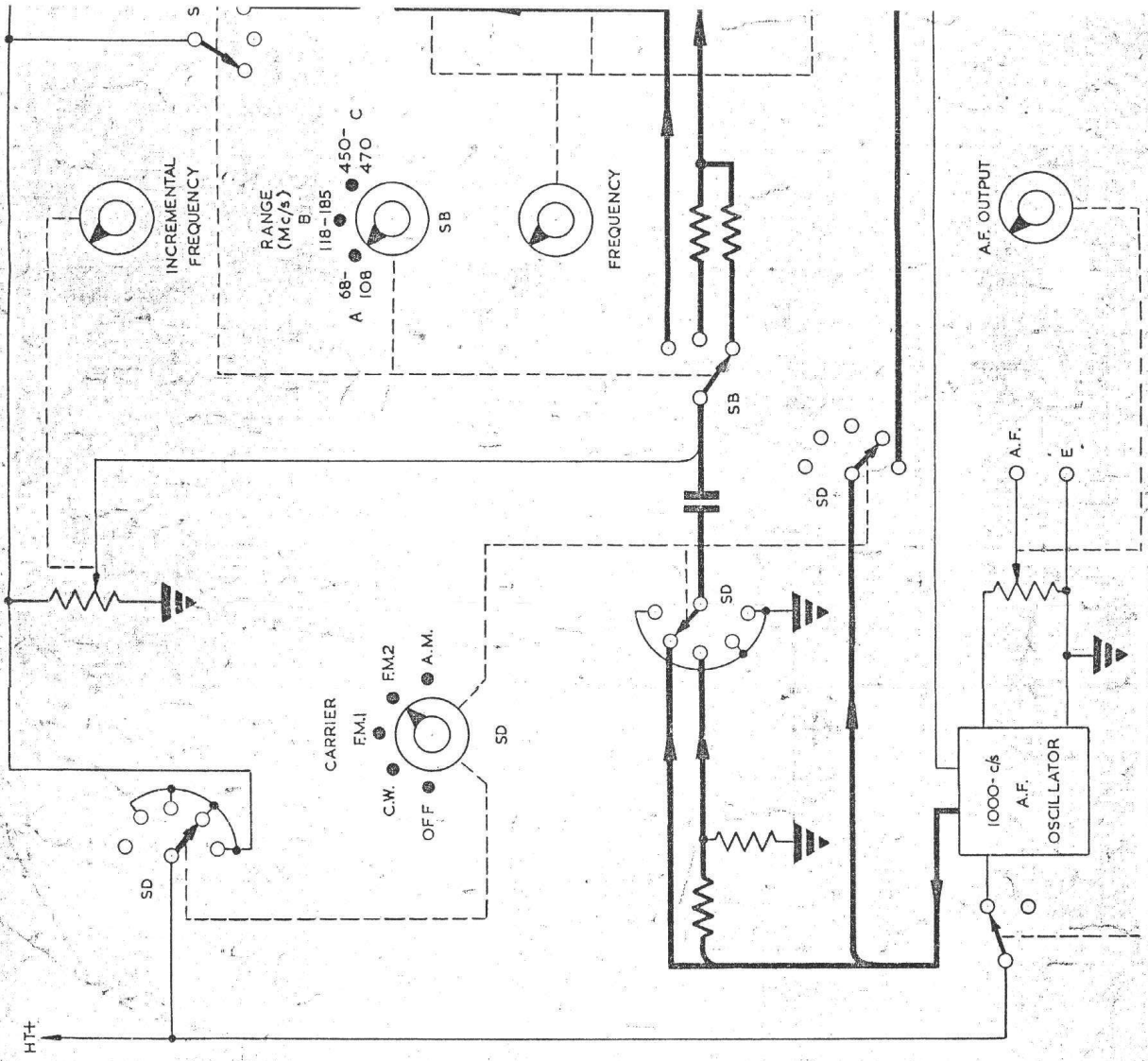

FUNCTIONAL DIAGRAM OF V.H.F. S

TITLE		FUNCTIONAL DIAGRAM OF V.H.F. SIGNAL GENERATOR TYPE TF1064B/5					
RAWN	DATE	CHKD	APPD.	TRCD.	ASSEMBLY	STOCK LIST	DRAWING NUMBER
1.C.	5/59	(Signature)		E.M.T.		TF 1064 B SERIES	XD 29930/5
MARCONI INSTRUMENTS LTD.						SHEET 1 OF 1 SHEET	

A B C D E F G

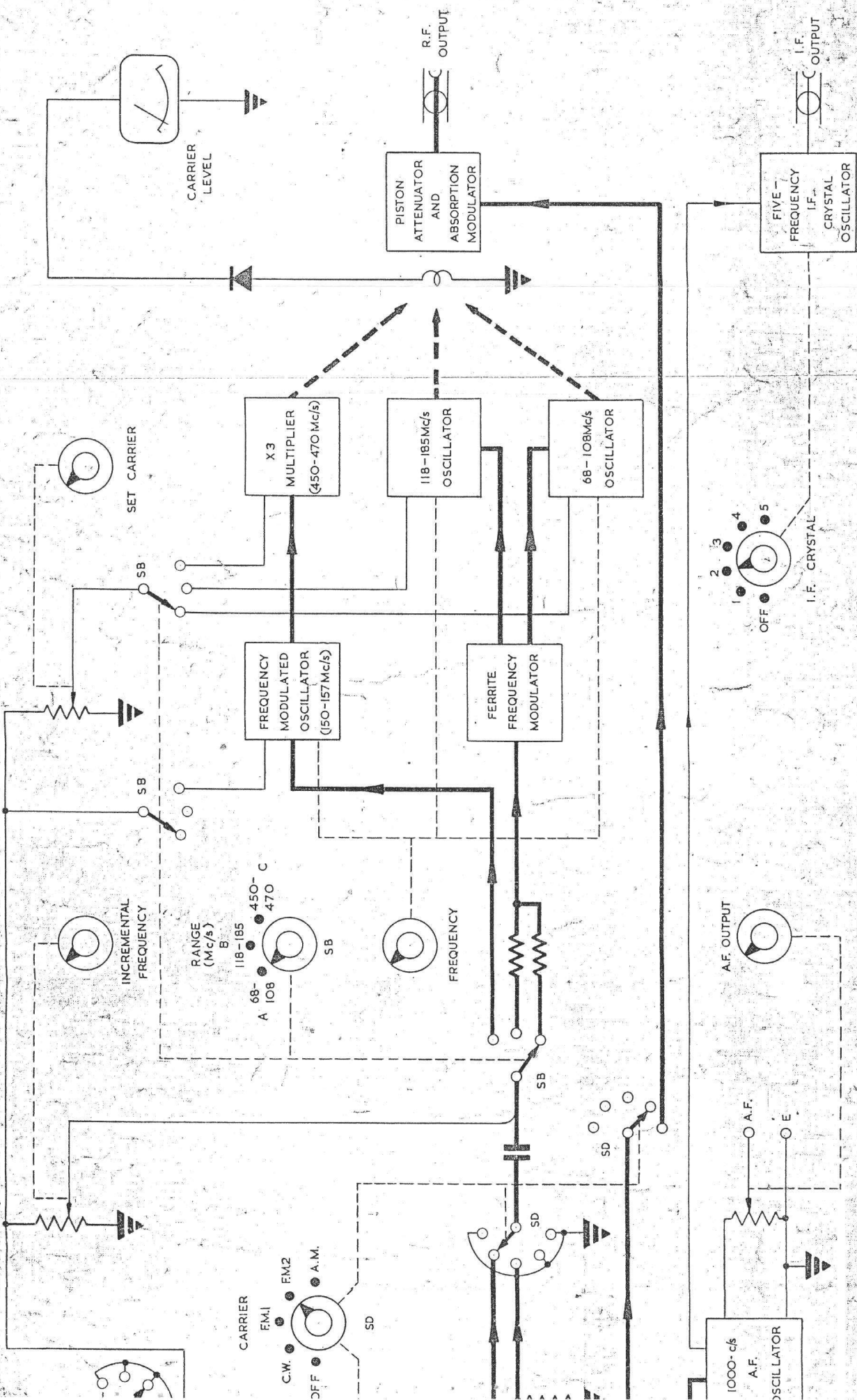

FUNCTIONAL DIAGRAM OF V.H.F. SIGNAL GENERATOR TYPE TF 1064B/5

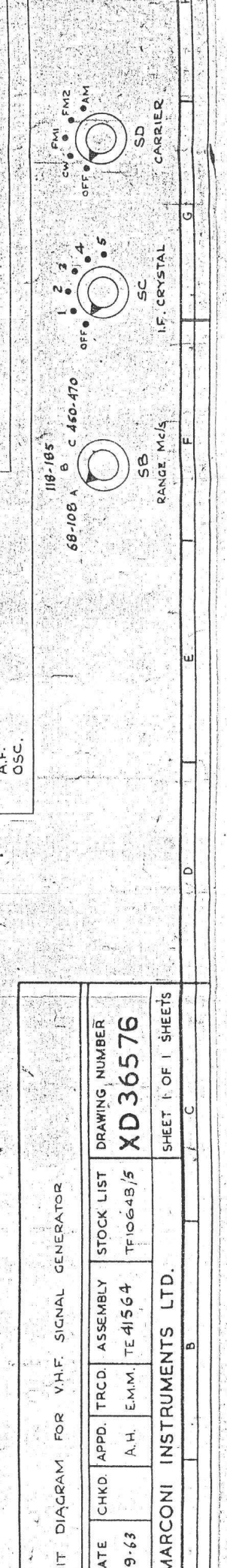
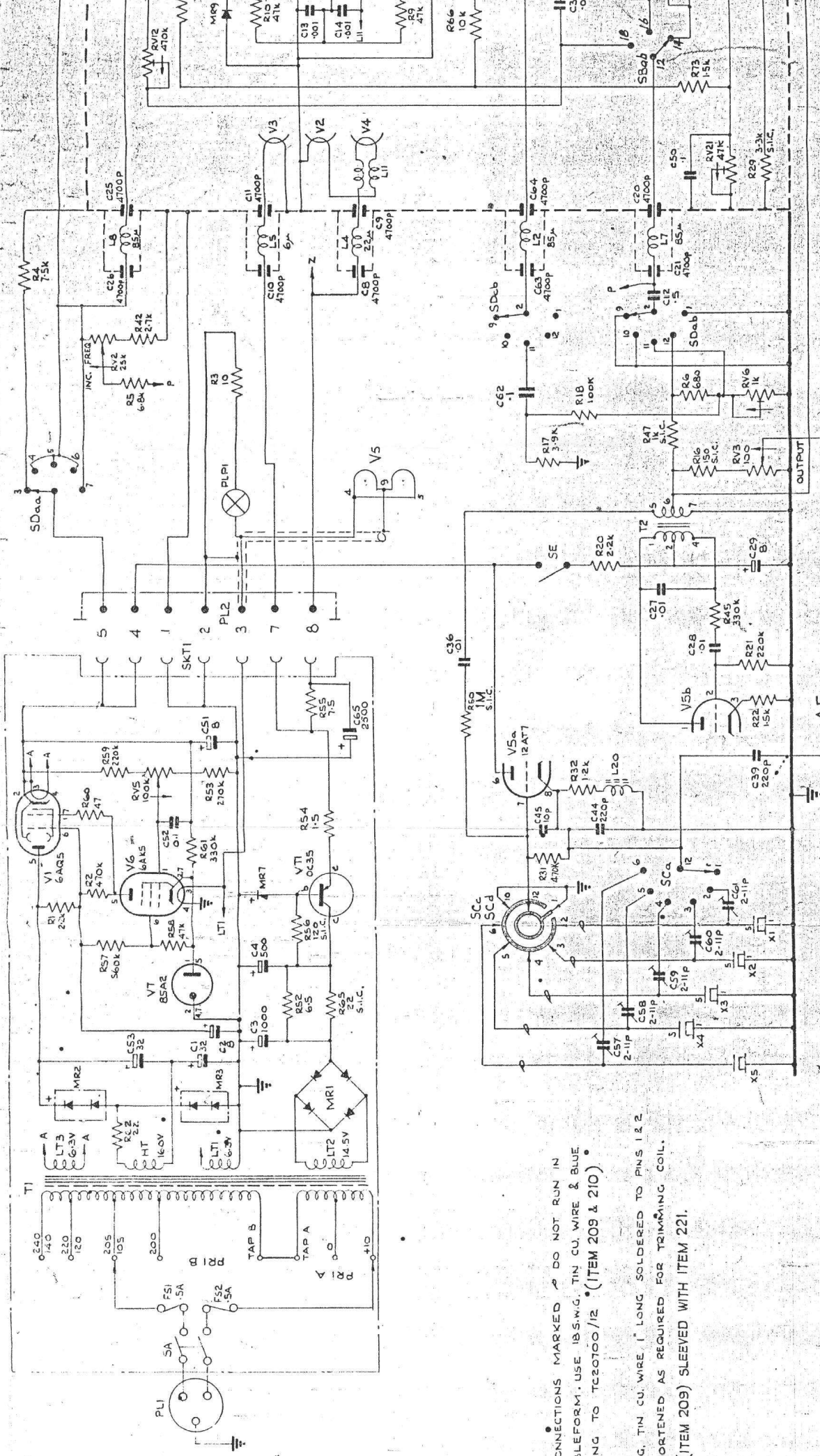

NOTES.

ALL CONNECTIONS MARKED \rightarrow DO NOT RUN IN A CABLEFORM. USE 18 SW.G. TIN CU. WIRE & BLUE SLEEVING TO T20700/12 (ITEM 209 & 210)

* 18 SW.G. TIN CU. WIRE 1" LONG SOLDERED TO PINS 1 & 2. V3, SHORTENED AS REQUIRED FOR TRIMMING COIL. WIRE (ITEM 209) SLEEVED WITH ITEM 221.

CIRCUIT DIAGRAM FOR V.H.F. SIGNAL GENERATOR

W.N	DATE	CHKD	APPD.	TRCD	ASSEMBLY	STOCK LIST	DRAWING NUMBER
LLUAMS	5-9-63	A.H.	E.M.M.	TE 41564	TF10648/5		XD36576
MARCONI INSTRUMENTS LTD.							SHEET 1 OF 1 SHEETS

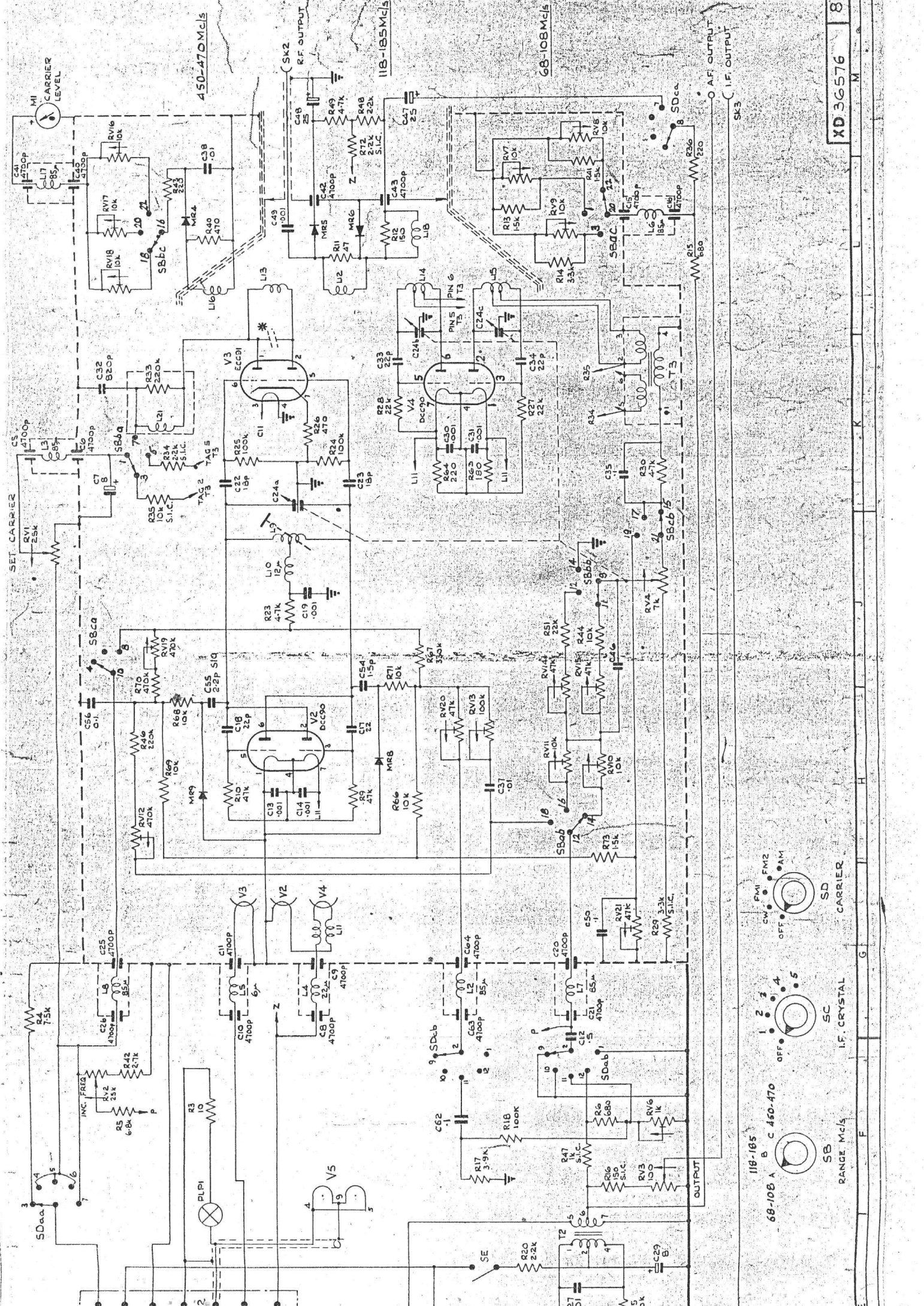

XD36576 8

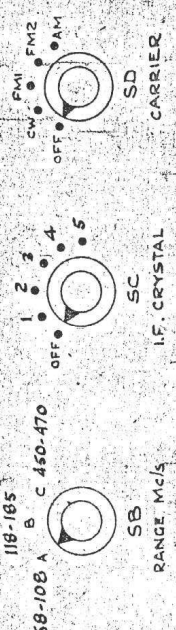

MARCONI INSTRUMENTS LIMITED

UK

Service Division
The Airport
LUTON
Bedfordshire LU2 9NS
Telephone: (0582) 33866
Telex: 825248

Head Office:
Longacres
ST. ALBANS
Hertfordshire AL4 0JN
Telephone: (0727) 59292
Telex: 23350
Fax: (0727) 57481 (Gp.3)

Microwave Products Division
(Service)
PO Box 10
Gunnels Wood Road
STEVENAGE
Hertfordshire SG1 2AU
Telephone: (0438) 312311
Telex: 82159

FRANCE

MARCONI INSTRUMENTS
Parc d'Activités du Canal
18 Rue du Plessis-Briard
Courcouronnes
91023 EVRY
Telephone: (6) 077 90 66
Telex: 690428
Fax: (6) 077 69 22

WEST GERMANY

MARCONI MESSTECHNIK GmbH
Postfach 153
Landsberger Strasse 65
8034 GERMERING
Telephone: (089) 84 50 85
Telex: 5212642
Fax: (089) 8419142 (Gp.3)

USA

MARCONI INSTRUMENTS
3 Pearl Court
Allendale Park
ALLENDALE
New Jersey 07401
Telephone: (201) 934 9050
Telex: 6853077 MIUSA
Twx: (710) 991 9752
Fax: (201) 934 9229