

SERVICE MANUAL



FISHER

MT-35R

**Belt-Drive
Semi-Automatic Turntable
(EUROPE)**



134 084 40

SPECIFICATIONS

TURNTABLE	MT-35R
Motor	4-Pole AC Synchronous
Drive System	Belt
Wow and Flutter (WRMS)	0.08 %
Rumble (DIN 45539B)	-55 dB
Speed Variation	±1.5 %
Platter Diameter	300mm
Platter Weight	0.6kg
Record Speed Selector	33-1/3 rpm/ 45 rpm
Automatic Functions	
Stop	Yes
Reject	Yes
Automatic Tonearm Return at End of Record	Yes
Manual Functions	
Start	Yes
Stop	Yes
Tonearm Data	
Resonance	<10 Hz
Effective Length	222 mm
Shape	Straight
Bearing Type	
Horizontal Friction Sensitivity	Thrust 0.15 g
Vertical Friction Sensitivity	Pivot 0.2 g
Max. Tracking Error	±1.8°
Cueing	Viscous Damped
GENERAL	
Power Requirements	AC 220 V (50 Hz)
Power Consumption	8 Watts
Dimensions (W x H x D)	398 x 342 x 112 mm
Weight (approx.)	3.3 kg

Because its products are subject to continuous improvement, Fisher Corporation reserves the right to modify product designs and specifications without notice and without incurring any obligation.

REPLACING THE CARTRIDGE

When replacing the cartridge, first unfasten the cartridge set screw, then pull the cartridge out gently as shown in Fig. 1. To mount another one, follow in the reverse order.

A pulug in T4P type cartridge should be used with this equipment.

NOTE:

When replacing the cartridge, the top surface of the cartridge must be lined up with the top surface of the tonearm. (Fig. 2).

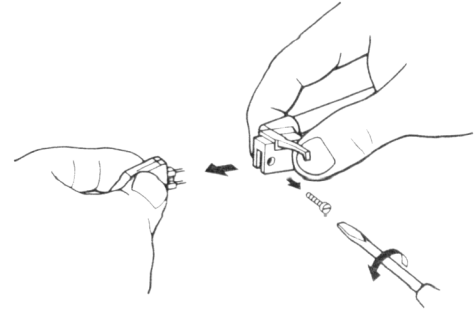

Fig. 1

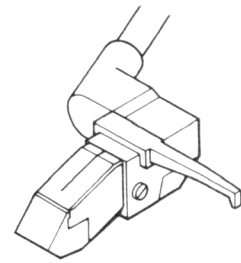

Fig. 2

MECHANICAL ADJUSTMENTS

PICK-UP ARM HEIGHT ADJUSTMENT

When using the cueing lever or the auto-return, perform the pick-up arm height adjustments by turning each adjusting screw as illustrated in (Fig. 3).

Turn the adjusting screw clockwise to raise the Pick-up Arm, and counter-clockwise to lower it.

PICK-UP RETURN POSITION ADJUSTMENT

Insert a screwdriver through the hole located on the plate bottom and under the arm. Turn the cam clockwise to move the return position inwards and counter-clockwise to move it outwards. When the cam is turned fully once, it returns to the original position.

PICK-UP ARM HEIGHT
ADJUSTMENT
(when Cueing Lever is used)

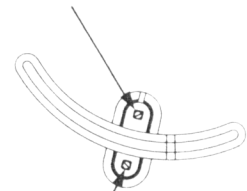

PICK-UP ARM HEIGHT
ADJUSTMENT
(when auto-return is used)

Fig. 3

CABINET & CHASSIS EXPLODED VIEW

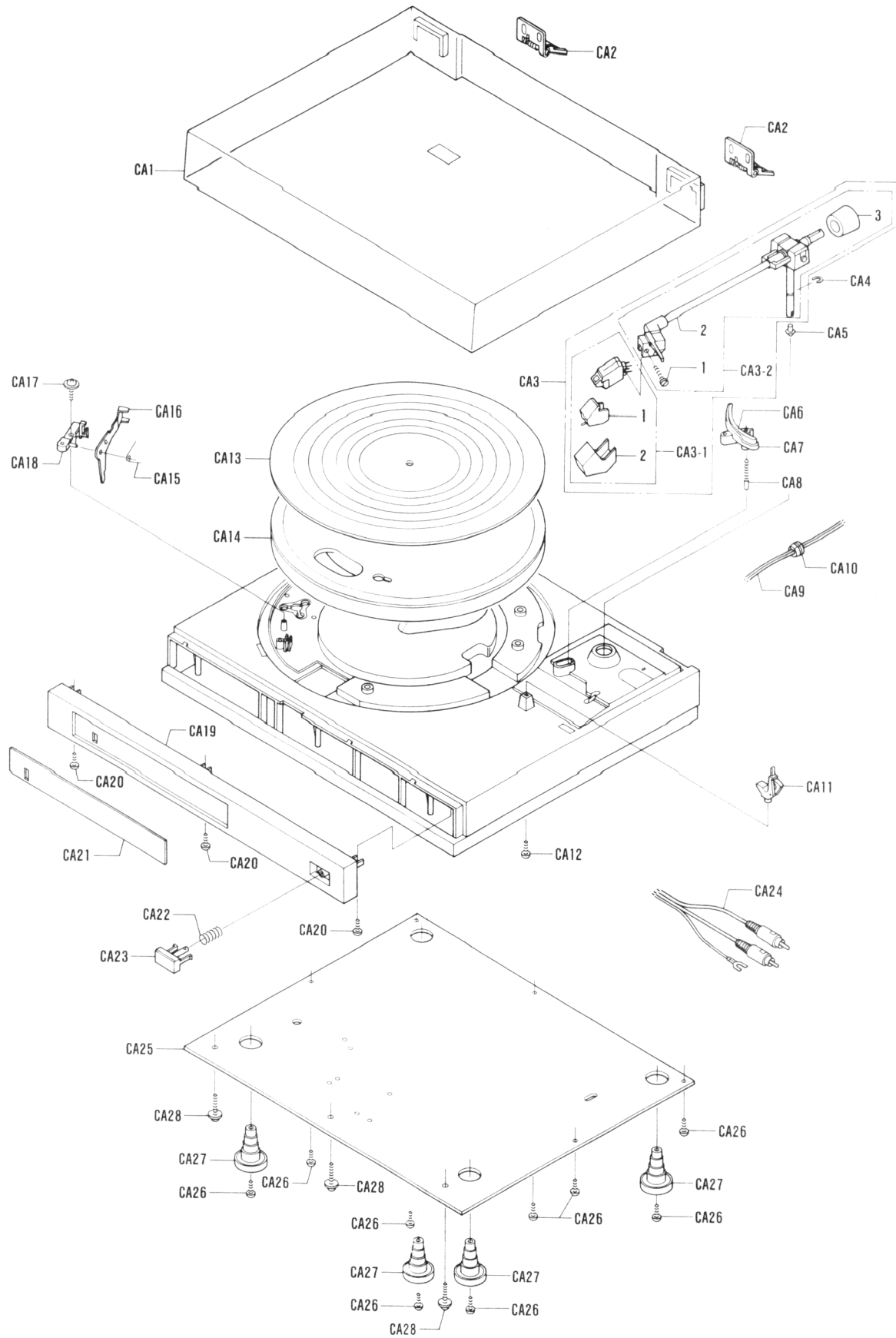

CABINET & CHASSIS EXPLODED VIEW (Continued)

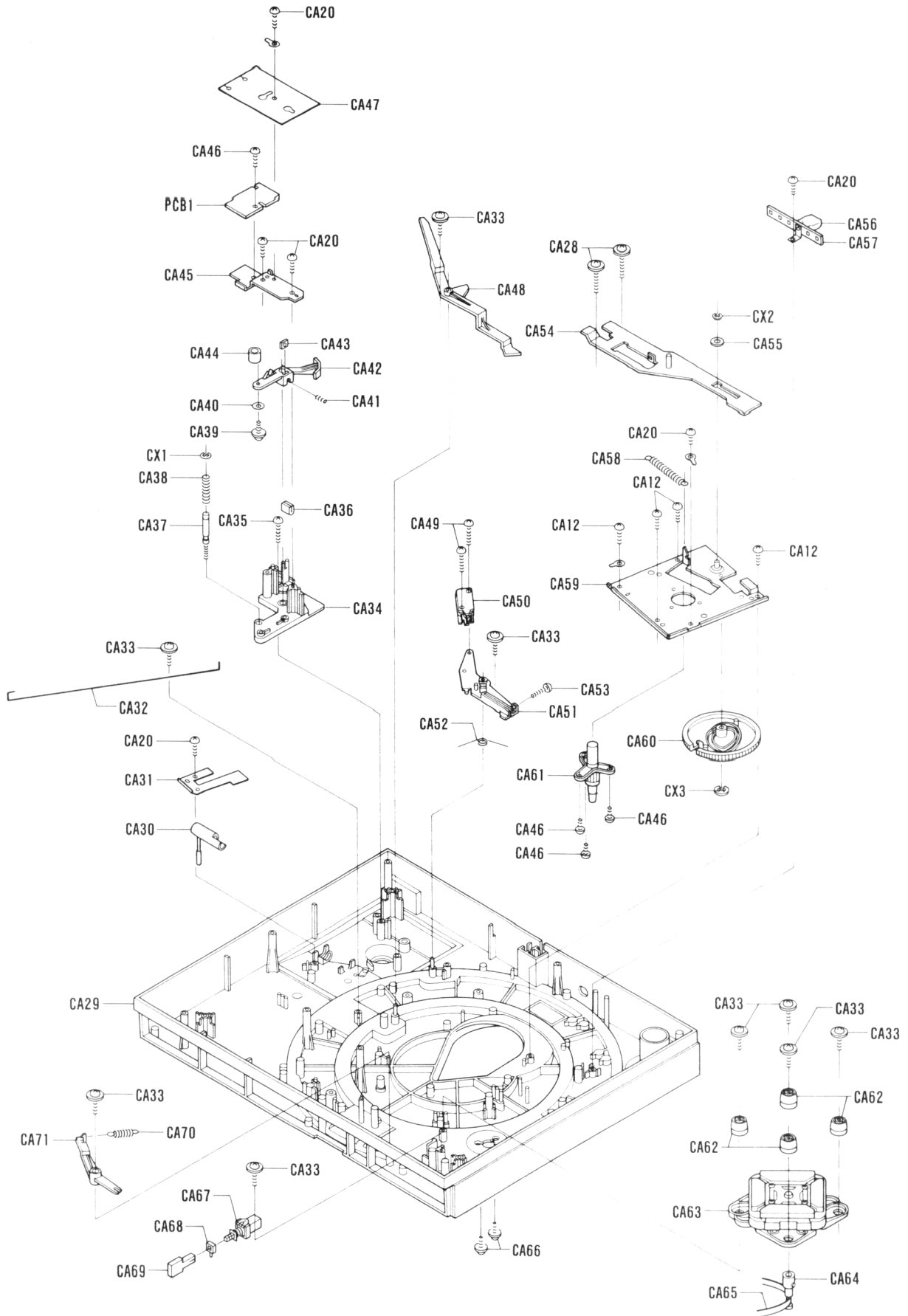

PARTS LIST

PRODUCT SAFETY NOTICE

Each precaution in this manual should be followed during servicing. Components identified with the IEC symbol \triangle in the parts list and the schematic diagram designate components in which safety can be of special significance. When replacing a component identified with \triangle , use only the replacement parts designated, or parts with the same ratings of resistance, wattage or voltage that are designated in the parts list in this manual.

Leakage-current or resistance measurements must be made to determine that exposed parts are acceptably insulated from the supply circuit before returning the product to the customer.

Ref. No.	Part No.	Description	Q'ty	Ref. No.	Part No.	Description	Q'ty
PACKAGE							
	131-6-2519-00201	Bag Polyethylene Ind	1	CA14	141-2-5229-00100	Turntable	1
	141-6-1139-85847	Box Corrugate-exp	1	CA15	141-2-8529-17200	Spring	1
	141-6-2519-16390	Bag Polyethylene-exp	1	CA16	141-2-7439-44500	Arm	1
	141-6-2519-16490	Bag Polyethylene-exp	1	CA17	131-2-4201-28301	Screw Button Hd. Tapping, +M3.0x12	1
	141-6-2519-16590	Bag Polyethylene-exp	3	CA18	141-2-8219-35200	Guide	1
	141-6-2519-20990	Bag Polyethylene-exp	1	CA19	141-2-1219-24926	Panel Front	1
	141-6-3119-21500	Pad Front	1	CA20	131-2-4201-19501	Screw Button Hd. Tapping-B, +M3.0x8	9
	141-6-3119-21600	Pad Rear	1	CA21	141-2-1449-55710	Plate Control	1
	141-6-3119-21800	Pad	1	CA22	141-2-8559-06100	Spring	1
	141-6-3119-23000	Pad	1	CA23	141-2-1659-20500	Knob	1
	141-6-3219-00100	Patching Sheet	1	CA24	131-0-4004-15003	Wire Shield Assy	1
	141-6-4559-03300	Serial No. Sheet	2	CA25	141-2-1259-05700	Plate Bottom	1
	141-6-4729-37352	Caution Label	1	CA26	131-2-4201-19504	Screw Button Hd. Tapping-B, +M3.0x14	9
ACCESSORY							
	131-6-2719-10801	Bag Fan	1	CA27	141-2-4459-31600	Cushion	4
	131-6-4519-15700	Guarantee Cert	1	CA28	131-2-4201-28303	Screw Button Hd. Tapping, +M3.0x16	5
	134-2-2901-11601	Adapter EP	1	CA29	141-2-1119-93014	Cabinet	1
	141-6-4559-03300	Serial No. Sheet	1	CA30	141-2-1629-08100	Knob	1
	142-6-4119-32409	Explanatory Booklet	1	CA31	141-2-8539-50600	Spring Plate	1
CABINET							
	4-2359-76250	Connector Assy	1	CA32	141-2-7359-02500	Rod	1
	131-2-3608-14100	Cramp Wire	4	CA33	131-2-4201-28300	Screw Button Hd. Tapping, +M3.0x10	10
	141-2-4729-08700	Cramp Wire	1	CA34	141-2-5739-06900	Base Pick-up	1
	131-2-3610-10400	Lug Egg Like	1	CA35	131-2-4201-19503	Screw Button Hd. Tapping-B, +M3.0x12	1
	141-2-1449-56235	Name Plate	1	CA36	134-2-5205-12000	Cushion	1
	141-6-4559-03300	Serial No. Sheet	1	CA37	134-2-4116-14000	Spindle Lifting	1
	141-6-4729-37604	Stylus Label	1	CA38	134-2-5101-24700	Spring	1
	\triangle 4-2239-70900	Mylar	0.01 μ F 250V \pm 20%	CA39	131-2-4201-21101	Screw, +M2.6x8	1
CA1	141-0-1249-32300	Lid Assy	1	CA40	131-2-4203-17501	Washer	1
CA2	141-0-2519-00900	Hinge Assy	2	CA41	131-2-4201-15202	Screw Headless Set, +M4.0x8	1
CA3	141-0-6419-01500	Pick-up Assy	1	CA42	141-2-7439-36500	Plate Pick-up Fix	1
CA3-1	4-1579-70060	Cartridge (MG-55)	1	CA43	141-2-4179-05400	Nut Plate	1
1	4-1579-70090	Stylus (ST-55D)	1	CA44	141-2-7519-63800	Cam	1
2	141-2-6459-00500	Retainer Needle	1	CA45	141-2-3519-66400	Plate	1
CA3-2	141-0-6419-01600	Tone Arm Assy	1	CA46	131-2-4201-19801	Screw Pan Hd., +M3.0x8	4
1	101-3-2502-01013	Screw, Cylinder Hd., -M2.0x10	1	CA47	141-2-3229-43000	Cover Shield	1
2	141-0-6429-00300	Pick-up Arm Assy	1	CA48	134-2-4123-21100	Arm	1
3	141-0-6439-00300	Pick-up Weight Assy	1	CA49	131-2-4201-19505	Screw Button Hd. Tapping-B, +M3.0x16	2
CA4	131-2-4220-10700	Ring Snap, M4.9x0.6	1	CA50	\triangle 4-2319-21995	Switch Micro (Power)	1
CA5	134-2-4117-10600	Support Shaft	1	CA51	134-2-4108-21000	Plate	1
CA6	134-2-5205-15500	Cushion	1	CA52	134-2-5101-26401	Spring	1
CA7	134-2-3310-12200	Support Arm	1	CA53	131-2-4201-13511	Screw Pan Hd., +M3.0x14	1
CA8	141-2-4219-30800	Screw	1	CA54	134-0-6035-11700	Return Plate Assy	1
CA9	\triangle 4-2432-00071	Power Cord	1	CA55	131-2-4203-95001	Washer, M4.2x10x1	1
CA10	131-2-6111-22900	Bushing (SR 4K-4)	1	CA56	131-2-6114-00900	Cover Safety	1
CA11	134-0-6031-12000	Arm Rest Assy	1	CA57	4-2379-70730	Terminal	1
CA12	131-2-4201-19502	Screw Button Hd. Tapping-B, +M3.0x10	5	CA58	141-2-8549-21500	Spring	1
CA13	134-2-6102-15702	Mat Turntable	1	CA59	141-0-3129-01800	Unit Plate Assy	1
				CA60	141-0-5519-11400	Gear Cycling Assy	1
				CA61	141-0-7519-03600	Shaft Turntable Complete	1
				CA62	141-2-4459-31500	Cushion Motor	4
				CA63	\triangle 4-5289-70111	Synchronous Motor	1
				CA64	141-2-3799-04100	Pulley Motor 50Hz	1
				CA65	141-2-5619-01901	Belt	1
				CA66	141-2-4219-31100	Screw Transit	2

PARTS LIST (Continued)

Ref. No.	Part No.	Description	Q'ty
CA67	4-2319-76200	Switch Push 0 Key	1
CA68	141-2-7539-40400	Pin	1
CA69	141-2-1659-20600	Knob	1
CA70	141-2-8549-21000	Spring	1
CA71	141-2-7419-88700	Lever	1
CX1	112-3-1302-00011	E Ring, M2.0	1
CX2	112-3-1303-00011	E Ring, M3.0	1
CX3	112-3-1304-00011	E Ring, M4.0	1
PCB1	4-1329-79160	Phono P.C.B. Assy	1
C1	CC1-0-3500-ZG00C	Ceramic 0.01 μ F 50V +80.-20%	1

NOTES:

1. Parts order must contain Model Number, Part Number and Description.
2. Ordering quantity of screws and resistors must be multiple of 10 pcs.

SCHEMATIC DIAGRAM

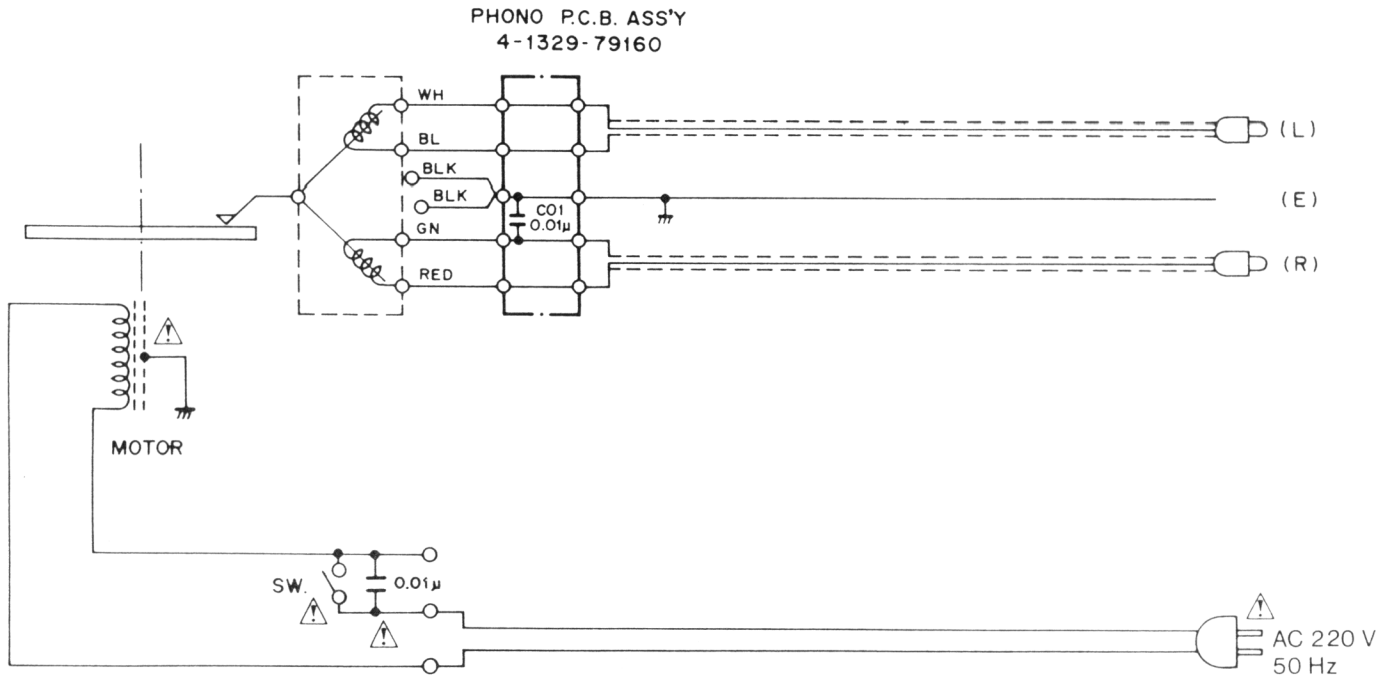



FISHER

FISHER HiFi Europa Vertriebs-GmbH
Service-Zentrale
Stahlgruberring 4
8000 München 82

Telefon: 089/42045-0
Telex: 524033

Abteilung

Service-Verwaltung
Color-TV
HiFi
Autoradio
Video
Ersatzteillager

Tel. Durchwahl

089-42045-151
089-42045-166
089-42045-168
089-42045-170
089-42045-172
089-42045-155/156

Printed in Japan

March/'85/2,000 **WM-14262**