



EMERSON AND THE G-CLEF LOGO ARE REGISTERED TRADEMARKS OF EMERSON RADIO CORP., PARSIPPANY, NEW JERSEY, U.S.A.

SERVICE MANUAL

This service manual shows only the differences between the model CR202EM9 and the original model CR202EM8. All other information is described in the service manual of the original model CR202EM8.

20" DIGITAL / ANALOG PURE FLAT TELEVISION

CR202EM9

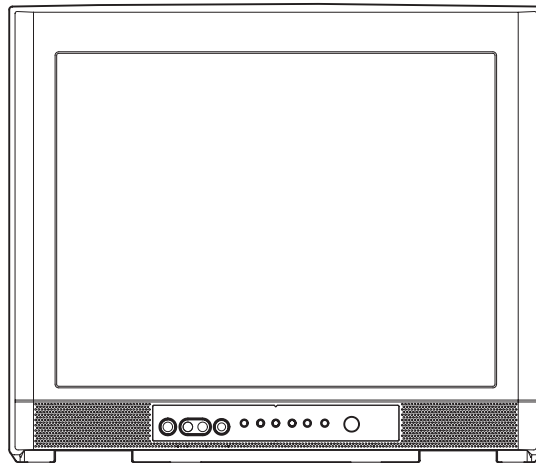
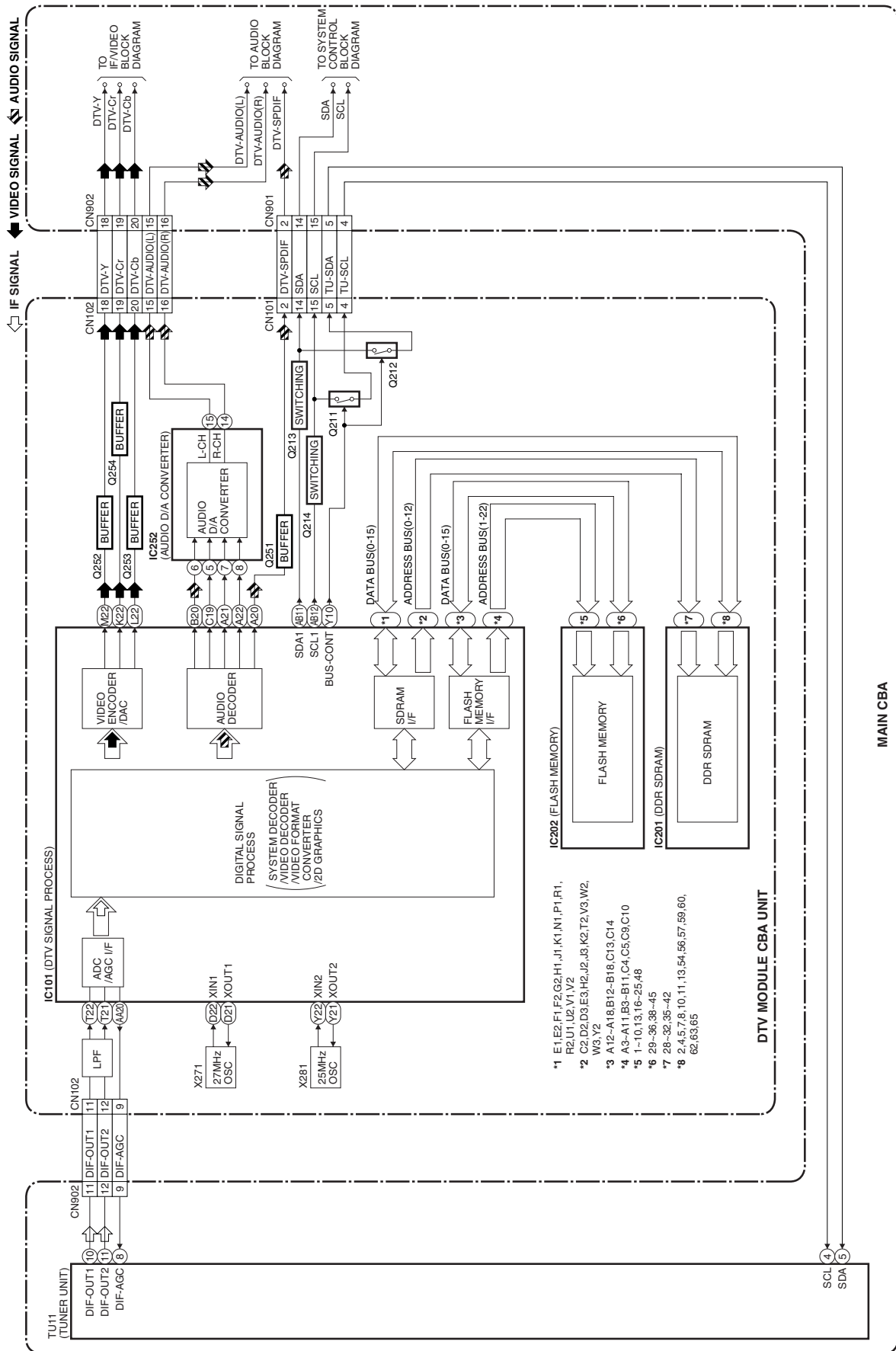

TABLE OF CONTENTS

Block Diagrams	1-1
Schematic Diagrams / CBA's and Test Points	2-1
Different parts from the original model (CR202EM8)	3-1

BLOCK DIAGRAMS

DTV Module Block Diagram



SCHEMATIC DIAGRAMS / CBA'S AND TEST POINTS

Standard Notes

WARNING

Many electrical and mechanical parts in this chassis have special characteristics. These characteristics often pass unnoticed and the protection afforded by them cannot necessarily be obtained by using replacement components rated for higher voltage, wattage, etc. Replacement parts that have these special safety characteristics are identified in this manual and its supplements; electrical components having such features are identified by the mark "▲" in the schematic diagram and the parts list. Before replacing any of these components, read the parts list in this manual carefully. The use of substitute replacement parts that do not have the same safety characteristics as specified in the parts list may create shock, fire, or other hazards.

Notes:

1. Do not use the part number shown on these drawings for ordering. The correct part number is shown in the parts list, and may be slightly different or amended since these drawings were prepared.
2. All resistance values are indicated in ohms (K = 10^3 , M = 10^6).
3. Resistor wattages are 1/4W or 1/6W unless otherwise specified.
4. All capacitance values are indicated in μF (P = 10^{-6} μF).
5. All voltages are DC voltages unless otherwise specified.

LIST OF CAUTION, NOTES, AND SYMBOLS USED IN THE SCHEMATIC DIAGRAMS ON THE FOLLOWING PAGES:

1. CAUTION:

CAUTION: FOR CONTINUED PROTECTION AGAINST RISK OF FIRE, REPLACE ONLY WITH SAME TYPE_A,_V FUSE.

ATTENTION: UTILISER UN FUSIBLE DE RECHANGE DE MÊME TYPE DE_A,_V.

2. CAUTION:

Fixed Voltage (or Auto voltage selectable) power supply circuit is used in this unit.

If Main Fuse (F601) is blown, first check to see that all components in the power supply circuit are not defective before you connect the AC plug to the AC power supply. Otherwise it may cause some components in the power supply circuit to fail.

3. Note:

- Do not use the part number shown on the drawings for ordering. The correct part number is shown in the parts list, and may be slightly different or amended since the drawings were prepared.
- To maintain original function and reliability of repaired units, use only original replacement parts which are listed with their part numbers in the parts list section of the service manual.

4. Voltage indications on the schematics are as shown below:

Plug the TV power cord into a standard AC outlet.:

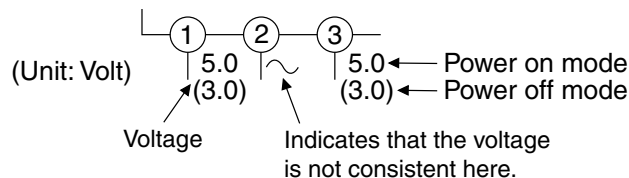

5. How to read converged lines

1-D3
 Distinction Area
 Line Number
 (1 to 3 digits)

Examples:

- "1-D3" means that line number "1" goes to the line number "1" of the area "D3".
- "1-B1" means that line number "1" goes to the line number "1" of the area "B1".

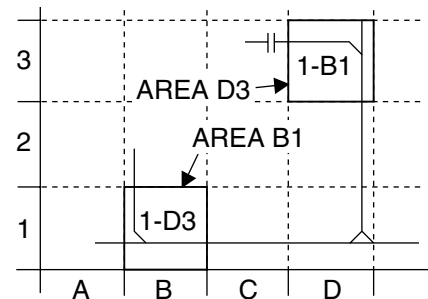

6. Test Point Information

: Indicates a test point with a jumper wire across a hole in the PCB.

: Used to indicate a test point with a component lead on foil side.

: Used to indicate a test point with no test pin.

: Used to indicate a test point with a test pin.

DTV Module 1/2 Schematic Diagram

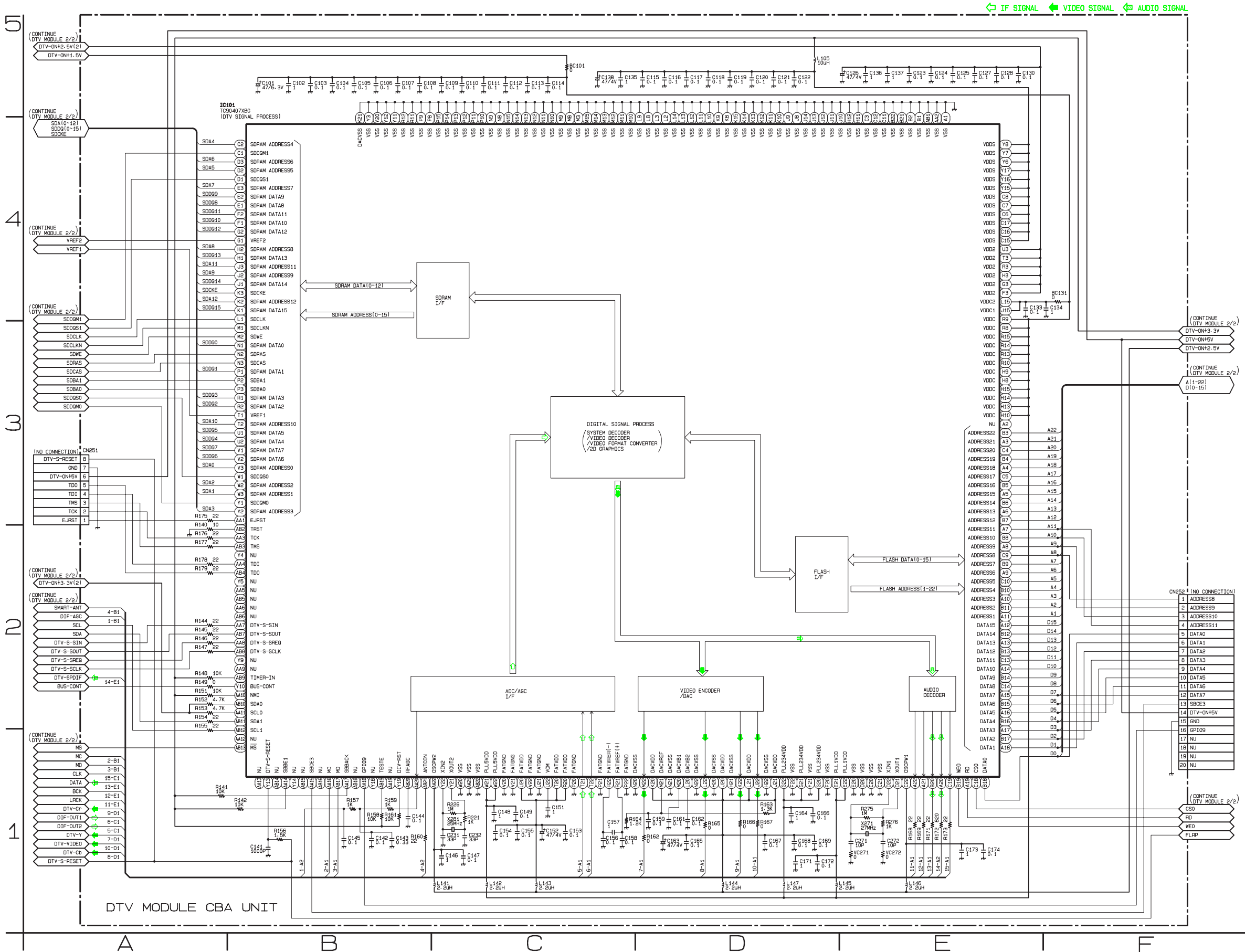

DTV Module 2/2 Schematic Diagram

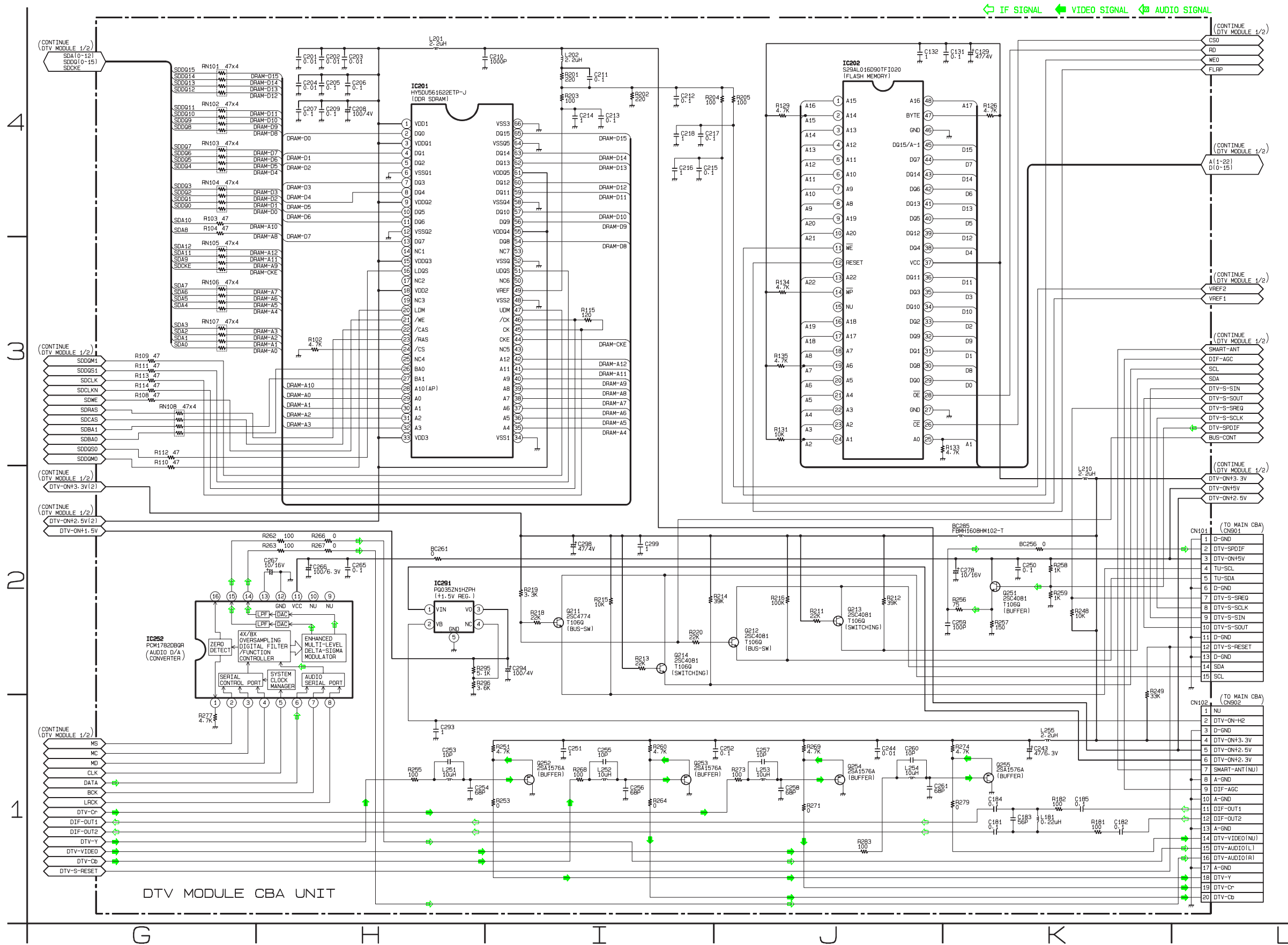

VOLTAGE CHART

CN101

Pin No.	Voltage
1	0
2	1.5
3	5.0
4	3.3
5	3.3
6	0
7	0
8	2.7
9	3.2
10	3.2
11	0
12	3.3
13	0
14	3.3
15	3.3

CN102

Pin No.	Voltage
1	---
2	4.8
3	0
4	3.3
5	2.5
6	2.3
7	---
8	0
9	0.5
10	0
11	0
12	0
13	0
14	---
15	2.4
16	2.4
17	0
18	~
19	~
20	~

Different parts from the original model (CR202EM8)

Ref. No.	Description	Part No.
MECHANICAL PARTS		
A1-1	FRONT CABINET P7156UT	1EM323979
A1-2	CONTROL PLATE P7156UT	1EM323978
A2	REAR CABINET P7150UT	1EM322891
A3▲	RATING LABEL P7156UT	-----
B1	SPRING TENSION B0080B0 EM40808	26WH006
B5	SPEAKER HOLDER L3330JA	1EM423600
S1	CARTON P7156UT	1EM425981
S2	STYROFOAM TOP ASSEMBLY L3300UA	1ESA10632
S3	STYROFOAM BOTTOM ASSEMBLY L3300UA	1ESA10633
S6	SET SHEET L1400UA 1000X1500	0EM406680
S7	Not used	
X2▲	OWNERS MANUAL ENGLISH	1EMN23060
X3	REMOTE CONTROL NE616UE 100/EMNL1701/NE616UE	-----
	Consists of the following:	
	FUNCTION INLAY NE616UE	1EM425897
	REMOCON ASSEMBLY NE609UZ	NE609UZ
ELECTRICAL PARTS		
	DTV MODULE CBA UNIT	1ESA14660
	MMA ASSEMBLY	1ESA16468
	MAIN CBA	-----
Q903	TRANSISTOR 2SD400(E)	QQUE002SD400
R844	METAL OXIDE FILM RES. 2W J 5.6 Ω	RN025R6DP004
R915	CARBON RES. 1/4W J 1.5 Ω	RCX4JATZ01R5
R916	CHIP RES. 1/10W F 5.6K Ω	RRXAFB5H5601
R932	CARBON RES. 1/4W J 1.5 Ω	RCX4JATZ01R5

© 2008 Funai Electric Co., Ltd.

All rights reserved. No part of this manual may be reproduced, copied, transmitted, disseminated, transcribed, downloaded or stored in any storage medium, in any form or for any purpose without the express prior written consent of Funai. Furthermore, any unauthorized commercial distribution of this manual or any revision hereto is strictly prohibited.

Information in this document is subject to change without notice. Funai reserves the right to change the content herein without the obligation to notify any person or organization of such changes.

FUNAI with the  design is a registered trademark of Funai Electric Co., Ltd and may not be used in any way without the express written consent of Funai. All other trademarks used herein remain the exclusive property of their respective owners. Nothing contained in this manual should be construed as granting, by implication or otherwise, any license or right to use any of the trademarks displayed herein. Misuse of any trademarks or any other content in this manual is strictly prohibited. Funai shall aggressively enforce its intellectual property rights to the fullest extent of the law.



EMERSON AND THE G-CLEF LOGO ARE REGISTERED TRADEMARKS
OF EMERSON RADIO CORP., PARSIPPANY, NEW JERSEY, U.S.A.

SERVICE MANUAL

**20" DIGITAL / ANALOG
PURE FLAT TELEVISION**

CR202EM8

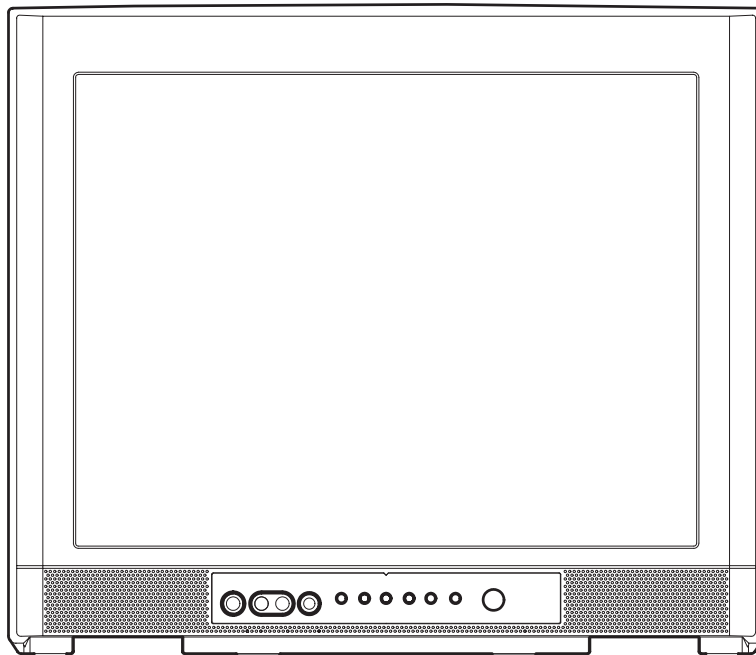

IMPORTANT SAFETY NOTICE

Proper service and repair is important to the safe, reliable operation of all Funai Equipment. The service procedures recommended by Funai and described in this service manual are effective methods of performing service operations. Some of these service special tools should be used when and as recommended.

It is important to note that this service manual contains various CAUTIONS and NOTICES which should be carefully read in order to minimize the risk of personal injury to service personnel. The possibility exists that improper service methods may damage the equipment. It also is important to understand that these CAUTIONS and NOTICES ARE NOT EXHAUSTIVE. Funai could not possibly know, evaluate and advice the service trade of all conceivable ways in which service might be done or of the possible hazardous consequences of each way. Consequently, Funai has not undertaken any such broad evaluation. Accordingly, a servicer who uses a service procedure or tool which is not recommended by Funai must first use all precautions thoroughly so that neither his safety nor the safe operation of the equipment will be jeopardized by the service method selected.

TABLE OF CONTENTS

Specifications	1-1
Important Safety Precautions	2-1
Standard Notes for Servicing	3-1
Cabinet Disassembly Instructions	4-1
Electrical Adjustment Instructions	5-1
How to initialize the Television	6-1
Block Diagrams	7-1
Schematic Diagrams / CBA's and Test Points	8-1
Waveforms	9-1
Wiring Diagram	10-1
IC Pin Function Descriptions	11-1
Exploded Views	12-1
Mechanical Parts List	13-1
Electrical Parts List	14-1

SPECIFICATIONS

< TUNER >

ANT. Input ----- 75 ohm Unbal., F type
 Reference Level----- 20 Vp-p (CRT Green Cathode)
 Test Input Signal ----- 400 Hz 30% modulation

Description	Condition	Unit	Nominal	Limit
1. Intermediate Freq.	Picture Sound	MHz	45.75	---
		MHz	41.25	---
2. Peak Picture Sens	VHF	dB μ V	15	30
	CATV	dB μ V	15	30
	UHF	dB μ V	15	40
3. AFT Pull In Range (10 mV input)	---	MHz	\pm 2.0	\pm 0.7

< DEFLECTION >

Description	Condition	Unit	Nominal	Limit
1. Deflection Freq.	Horizontal Vertical	kHz	15.734	---
		Hz	60	---
2. Linearity	Horizontal Vertical	%	---	\pm 18
		%	---	\pm 10
3. Over Scan	---	%	10	---
4. High Voltage	---	kV	25	---

< VIDEO & CHROMA >

Description	Condition	Unit	Nominal	Limit
1. Misconvergence	Center	mm	---	0.4
	Side	mm	---	1.5
	Corner	mm	---	2.5
2. Brightness	APL 100%	Ft-L	25	15
3. Color Temperature	---	$^{\circ}$ K	9200	---
4. Resolution	Horizontal Vertical	Line	250	---
		Line	300	---

< AUDIO >

All items are measured across 8 Ω load at speaker output terminal.

Description	Condition	Unit	Nominal	Limit
1. Audio Output Power	10% THD	W	1	0.8
2. Audio Distortion (w/LPF)	500 mW	%	2	7
3. Audio Freq. Response	-3 dB	Hz	70 ~ 11 k	---

< ATSC >

Description	Condition	Unit	Nominal	Limit
1. RECEIVED FREQ. RANGE (-28dBm)	+	kHz	150	>100
	-			
2. ATSC DYNAMIC RANGE (min./max.)	VHF LOW BAND. CH.4	dBm	-82/6	-76/0
	VHF HI BAND. CH.10		-82/6	-76/0
	UHF BAND. CH.41		-80/6	-74/4
3. ATSC SUSCEPTIBILITY TO RANDOM NOISE	VHF LOW BAND. CH.4	dB	23	<26
	VHF HI BAND. CH.10			
	UHF BAND. CH.41			
4. NTSC CO-CHANNEL INTERFERENCE	VHF LOW BAND. CH.4	dB	0	>-6
	VHF HI BAND. CH.10			
	UHF BAND. CH.41			
5. MULTIPATH	A	dB	0	<6
	B			
	C			
	D			
	E			
	F			
	FF			
	G			
6. Audio S/N (0dBfs)	Lch	dB	60	>50
	Rch			
7. Audio DIST. (0dBfs)	Lch	%	0.5	<3
	Rch			

Note: Nominal specifications represent the design specifications. All units should be able to approximate these. Some will exceed and some may drop slightly below these specifications. Limit specifications represent the absolute worst condition that still might be considered acceptable. In no case should a unit fail to meet limit specifications.

IMPORTANT SAFETY PRECAUTIONS

Prior to shipment from the factory, our products are strictly inspected for recognized product safety and electrical codes of the countries in which they are to be sold. However, in order to maintain such compliance, it is equally important to implement the following precautions when a set is being serviced.

Safety Precautions for TV Circuit

1. **Before returning an instrument to the customer**, always make a safety check of the entire instrument, including, but not limited to, the following items:
 - a. Be sure that no built-in protective devices are defective and have been defeated during servicing. (1) Protective shields are provided on this chassis to protect both the technician and the customer. Correctly replace all missing protective shields, including any removed for servicing convenience. (2) When reinstalling the chassis and/or other assembly in the cabinet, be sure to put back in place all protective devices, including but not limited to, nonmetallic control knobs, insulating fishpapers, adjustment and compartment covers/shields, and isolation resistor/capacitor networks. **Do not operate this instrument or permit it to be operated without all protective devices correctly installed and functioning. Servicers who defeat safety features or fail to perform safety checks may be liable for any resulting damage.**
 - b. Be sure that there are no cabinet openings through which an adult or child might be able to insert their fingers and contact a hazardous voltage. Such openings include, but are not limited to, (1) spacing between the picture tube and the cabinet mask, (2) excessively wide cabinet ventilation slots, and (3) an improperly fitted and/or incorrectly secured cabinet back cover.
 - c. **Antenna Cold Check** - With the instrument AC plug removed from any AC source, connect an electrical jumper across the two AC plug prongs. Place the instrument AC switch in the on position. Connect one lead of an ohmmeter to the AC plug prongs tied together and touch the other ohmmeter lead in turn to each tuner antenna input exposed terminal screw and, if applicable, to the coaxial connector. If the measured resistance is less than 1.0 megohm or greater than 5.2 megohm, an abnormality exists that must be corrected before the instrument is returned to the customer. Repeat this test with the instrument AC switch in the off position.
 - d. **Leakage Current Hot Check** - With the instrument completely reassembled, plug the

AC line cord directly into a 120 V AC outlet. (Do not use an isolation transformer during this test.) Use a leakage current tester or a metering system that complies with American National Standards Institute (ANSI) C101.1 Leakage Current for Appliances and Underwriters Laboratories (UL) 1410, (50.7). With the instrument AC switch first in the on position and then in the off position, measure from a known earth ground (metal water pipe, conduit, etc.) to all exposed metal parts of the instrument (antennas, handle brackets, metal cabinet, screw heads, metallic overlays, control shafts, etc.), especially any exposed metal parts that offer an electrical return path to the chassis. Any current measured must not exceed 0.5 milli-ampere. Reverse the instrument power cord plug in the outlet and repeat the test.

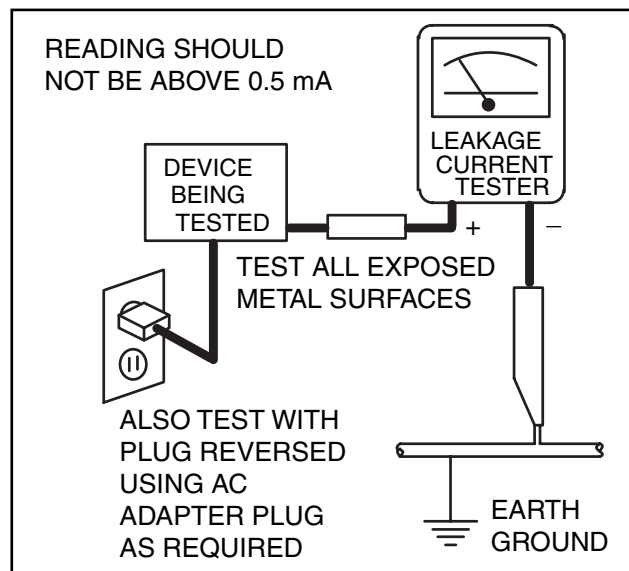

ANY MEASUREMENTS NOT WITHIN THE LIMITS SPECIFIED HEREIN INDICATE A POTENTIAL SHOCK HAZARD THAT MUST BE ELIMINATED BEFORE RETURNING THE INSTRUMENT TO THE CUSTOMER OR BEFORE CONNECTING THE ANTENNA OR ACCESSORIES.

- e. **X-Radiation and High Voltage Limits** - Because the picture tube is the primary potential source of X-radiation in solid-state TV receivers, it is specially constructed to prohibit X-radiation emissions. For continued X-radiation protection, the replacement picture tube must be the same type as the original.

Also, because the picture tube shields and mounting hardware perform an X-radiation protection function, they must be correctly in place. High voltage must be measured each time servicing is performed that involves B+, horizontal deflection or high voltage. Correct operation of the X-radiation protection circuits also must be reconfirmed each time they are serviced. (X-radiation protection circuits also may be called “horizontal disable” or “hold down.”) Read and apply the high voltage limits and, if the chassis is so equipped, the X-radiation protection circuit specifications given on instrument labels and in the Product Safety & X-Radiation Warning note on the service data chassis schematic. High voltage is maintained within specified limits by close tolerance safety-related components/adjustments in the high-voltage circuit. If high voltage exceeds specified limits, check each component specified on the chassis schematic and take corrective action.

2. Read and comply with all caution and safety-related notes on or inside the receiver cabinet, on the receiver chassis, or on the picture tube.
3. **Design Alteration Warning** - Do not alter or add to the mechanical or electrical design of this TV receiver. Design alterations and additions, including, but not limited to circuit modifications and the addition of items such as auxiliary audio and/or video output connections, might alter the safety characteristics of this receiver and create a hazard to the user. Any design alterations or additions will void the manufacturer's warranty and may make you, the servicer, responsible for personal injury or property damage resulting therefrom.
4. **Picture Tube Implosion Protection Warning** - The picture tube in this receiver employs integral implosion protection. For continued implosion protection, replace the picture tube only with one of the same type number. Do not remove, install, or otherwise handle the picture tube in any manner without first putting on shatterproof goggles equipped with side shields. People not so equipped must be kept safely away while picture tubes are handled. Keep the picture tube away from your body. Do not handle the picture tube by its neck. Some “in-line” picture tubes are equipped with a permanently attached deflection yoke; because of potential hazard, do not try to remove such “permanently attached” yokes from the picture tube.
5. **Hot Chassis Warning** -
 - a. Some TV receiver chassis are electrically connected directly to one conductor of the AC power cord and maybe safety-serviced without

an isolation transformer only if the AC power plug is inserted so that the chassis is connected to the ground side of the AC power source. To confirm that the AC power plug is inserted correctly, with an AC voltmeter, measure between the chassis and a known earth ground. If a voltage reading in excess of 1.0V is obtained, remove and reinsert the AC power plug in the opposite polarity and again measure the voltage potential between the chassis and a known earth ground.

- b. Some TV receiver chassis normally have 85V AC(RMS) between chassis and earth ground regardless of the AC plug polarity. This chassis can be safety-serviced only with an isolation transformer inserted in the power line between the receiver and the AC power source, for both personnel and test equipment protection.
 - c. Some TV receiver chassis have a secondary ground system in addition to the main chassis ground. This secondary ground system is not isolated from the AC power line. The two ground systems are electrically separated by insulation material that must not be defeated or altered.
6. Observe original lead dress. Take extra care to assure correct lead dress in the following areas: a. near sharp edges, b. near thermally hot parts-be sure that leads and components do not touch thermally hot parts, c. the AC supply, d. high voltage, and, e. antenna wiring. Always inspect in all areas for pinched, out of place, or frayed wiring. Check AC power cord for damage.
 7. Components, parts, and/or wiring that appear to have overheated or are otherwise damaged should be replaced with components, parts, or wiring that meet original specifications. Additionally, determine the cause of overheating and/or damage and, if necessary, take corrective action to remove any potential safety hazard.
 8. **Product Safety Notice** - Some electrical and mechanical parts have special safety-related characteristics which are often not evident from visual inspection, nor can the protection they give necessarily be obtained by replacing them with components rated for higher voltage, wattage, etc. Parts that have special safety characteristics are identified by a  on schematics and in parts lists. Use of a substitute replacement that does not have the same safety characteristics as the recommended replacement part might create shock, fire, and/or other hazards. The product's safety is under review continuously and new instructions are issued whenever appropriate. Prior to shipment from the factory, our products are strictly inspected to confirm they comply with the recognized product safety and electrical codes

of the countries in which they are to be sold. However, in order to maintain such compliance, it is equally important to implement the following precautions when a set is being serviced.

Precautions during Servicing

- A.** Parts identified by the  symbol are critical for safety.
Replace only with part number specified.
- B.** In addition to safety, other parts and assemblies are specified for conformance with regulations applying to spurious radiation. These must also be replaced only with specified replacements.
Examples: RF converters, RF cables, noise blocking capacitors, and noise blocking filters, etc.
- C.** Use specified internal wiring. Note especially:
 - 1) Wires covered with PVC tubing
 - 2) Double insulated wires
 - 3) High voltage leads
- D.** Use specified insulating materials for hazardous live parts. Note especially:
 - 1) Insulation Tape
 - 2) PVC tubing
 - 3) Spacers
 - 4) Insulators for transistors.
- E.** When replacing AC primary side components (transformers, power cord, etc.), wrap ends of wires securely about the terminals before soldering.
- F.** Observe that the wires do not contact heat producing parts (heat sinks, oxide metal film resistors, fusible resistors, etc.)
- G.** Check that replaced wires do not contact sharp edged or pointed parts.
- H.** When a power cord has been replaced, check that 5~6 kg of force in any direction will not loosen it.
- I.** Also check areas surrounding repaired locations.
- J.** Use care that foreign objects (screws, solder droplets, etc.) do not remain inside the set.
- K.** Crimp type wire connector
The power transformer uses crimp type connectors which connect the power cord and the primary side of the transformer. When replacing the transformer, follow these steps carefully and precisely to prevent shock hazards.
Replacement procedure
 - 1) Remove the old connector by cutting the wires at a point close to the connector.
Important: Do not re-use a connector (discard it).
 - 2) Strip about 15 mm of the insulation from the ends of the wires. If the wires are stranded, twist the strands to avoid frayed conductors.

- 3) Align the lengths of the wires to be connected. Insert the wires fully into the connector.
- 4) Use the crimping tool to crimp the metal sleeve at the center position. Be sure to crimp fully to the complete closure of the tool.
- L.** When connecting or disconnecting the internal connectors, first, disconnect the AC plug from the AC supply outlet.

Safety Check after Servicing

Examine the area surrounding the repaired location for damage or deterioration. Observe that screws, parts and wires have been returned to original positions. Afterwards, perform the following tests and confirm the specified values in order to verify compliance with safety standards.

1. Clearance Distance

When replacing primary circuit components, confirm specified clearance distance (d) and (d') between soldered terminals, and between terminals and surrounding metallic parts. (See Fig. 1)

Table 1: Ratings for selected area

AC Line Voltage	Region	Clearance Distance (d), (d')
110 to 130 V	U.S.A. or Canada	≥ 3.2 mm (0.126 inches)

Note: This table is unofficial and for reference only. Be sure to confirm the precise values.

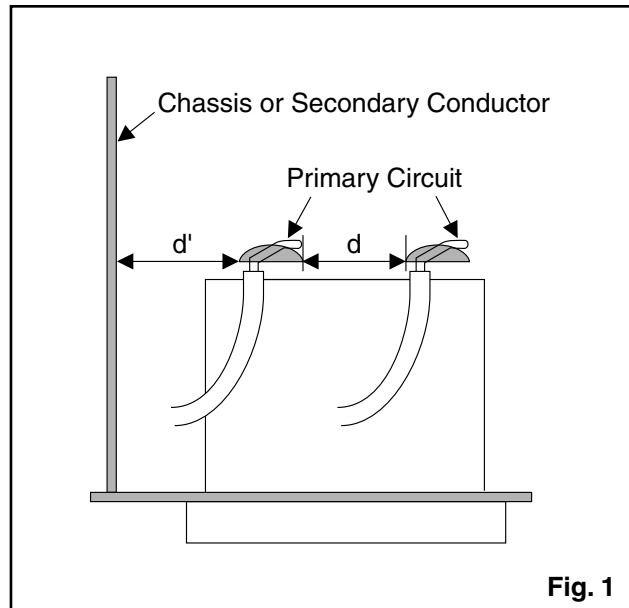

Fig. 1

2. Leakage Current Test

Confirm the specified (or lower) leakage current between B (earth ground, power cord plug prongs) and externally exposed accessible parts (RF terminals, antenna terminals, video and audio input and output terminals, microphone jacks, earphone jacks, etc.) is lower than or equal to the specified value in the table below.

Measuring Method: (Power ON)

Insert load Z between B (earth ground, power cord plug prongs) and exposed accessible parts. Use an AC voltmeter to measure across both terminals of load Z. See Fig. 2 and following table.

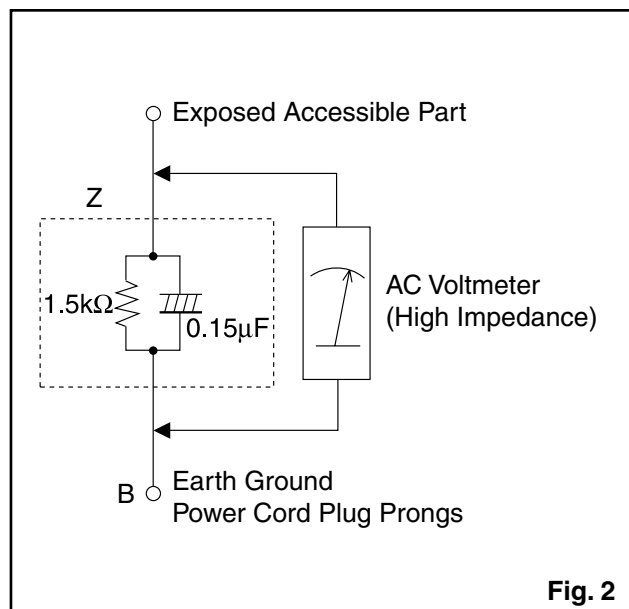

Fig. 2

Table 2: Leakage current ratings for selected areas

AC Line Voltage	Region	Load Z	Leakage Current (i)	Earth Ground (B) to:
110 to 130 V	U.S.A. or Canada	$0.15\mu\text{F}$ CAP. & $1.5\text{k}\Omega$ RES. Connected in parallel	$i \leq 0.5$ mA rms	Exposed accessible parts

Note: This table is unofficial and for reference only. Be sure to confirm the precise values.

STANDARD NOTES FOR SERVICING

Circuit Board Indications

1. The output pin of the 3 pin Regulator ICs is indicated as shown.

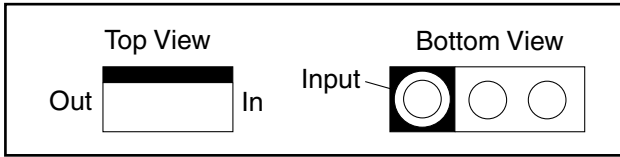

2. For other ICs, pin 1 and every fifth pin are indicated as shown.

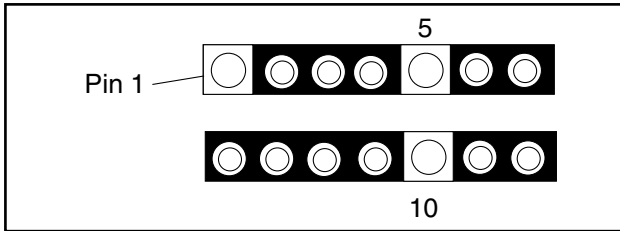

3. The 1st pin of every male connector is indicated as shown.

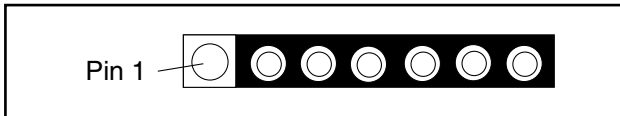

Pb (Lead) Free Solder

Pb free mark will be found on PCBs which use Pb free solder. (Refer to figure.) For PCBs with Pb free mark, be sure to use Pb free solder. For PCBs without Pb free mark, use standard solder.

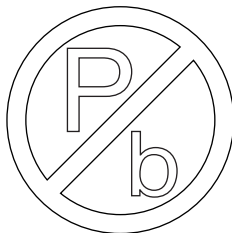

Pb free mark

How to Remove / Install Flat Pack-IC

1. Removal

With Hot-Air Flat Pack-IC Desoldering Machine:

1. Prepare the hot-air flat pack-IC desoldering machine, then apply hot air to the Flat Pack-IC (about 5 to 6 seconds). (Fig. S-1-1)

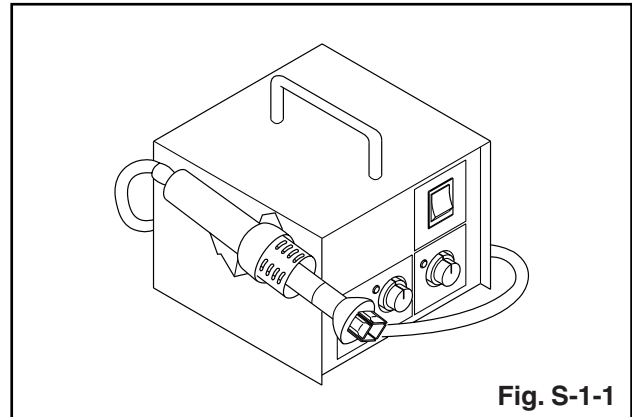

Fig. S-1-1

2. Remove the flat pack-IC with tweezers while applying the hot air.
3. Bottom of the flat pack-IC is fixed with glue to the CBA; when removing entire flat pack-IC, first apply soldering iron to center of the flat pack-IC and heat up. Then remove (glue will be melted). (Fig. S-1-6)
4. Release the flat pack-IC from the CBA using tweezers. (Fig. S-1-6)

CAUTION:

1. The Flat Pack-IC shape may differ by models. Use an appropriate hot-air flat pack-IC desoldering machine, whose shape matches that of the Flat Pack-IC.
2. Do not supply hot air to the chip parts around the flat pack-IC for over 6 seconds because damage to the chip parts may occur. Put masking tape around the flat pack-IC to protect other parts from damage. (Fig. S-1-2)

3. The flat pack-IC on the CBA is affixed with glue, so be careful not to break or damage the foil of each pin or the solder lands under the IC when removing it.

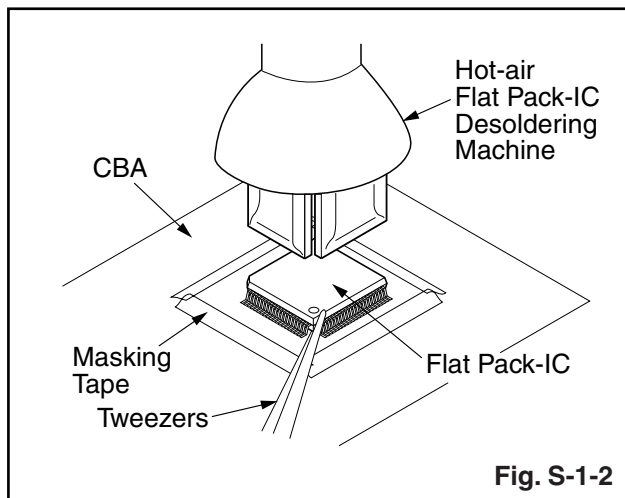

With Soldering Iron:

1. Using desoldering braid, remove the solder from all pins of the flat pack-IC. When you use solder flux which is applied to all pins of the flat pack-IC, you can remove it easily. (Fig. S-1-3)

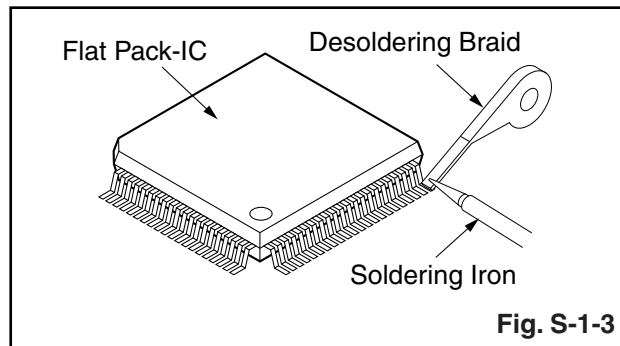

2. Lift each lead of the flat pack-IC upward one by one, using a sharp pin or wire to which solder will not adhere (iron wire). When heating the pins, use a fine tip soldering iron or a hot air desoldering machine. (Fig. S-1-4)

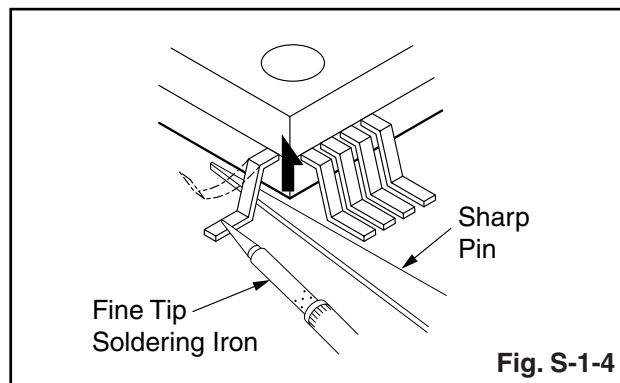

3. Bottom of the flat pack-IC is fixed with glue to the CBA; when removing entire flat pack-IC, first apply soldering iron to center of the flat pack-IC and heat up. Then remove (glue will be melted). (Fig. S-1-6)
4. Release the flat pack-IC from the CBA using tweezers. (Fig. S-1-6)

With Iron Wire:

1. Using desoldering braid, remove the solder from all pins of the flat pack-IC. When you use solder flux which is applied to all pins of the flat pack-IC, you can remove it easily. (Fig. S-1-3)
2. Affix the wire to a workbench or solid mounting point, as shown in Fig. S-1-5.
3. While heating the pins using a fine tip soldering iron or hot air blower, pull up the wire as the solder melts so as to lift the IC leads from the CBA contact pads as shown in Fig. S-1-5.
4. Bottom of the flat pack-IC is fixed with glue to the CBA; when removing entire flat pack-IC, first apply soldering iron to center of the flat pack-IC and heat up. Then remove (glue will be melted). (Fig. S-1-6)
5. Release the flat pack-IC from the CBA using tweezers. (Fig. S-1-6)

Note: When using a soldering iron, care must be taken to ensure that the flat pack-IC is not being held by glue. When the flat pack-IC is removed from the CBA, handle it gently because it may be damaged if force is applied.

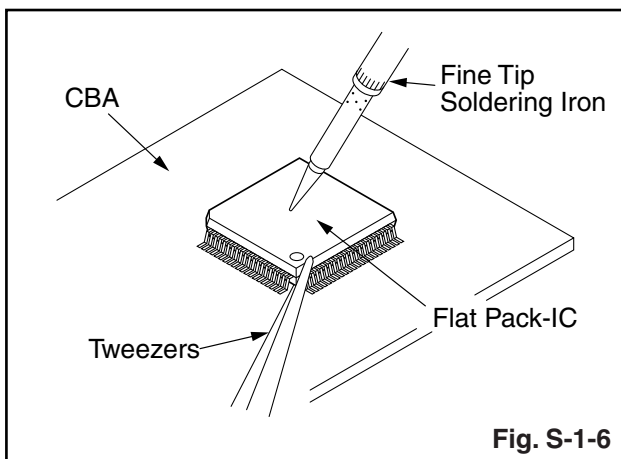
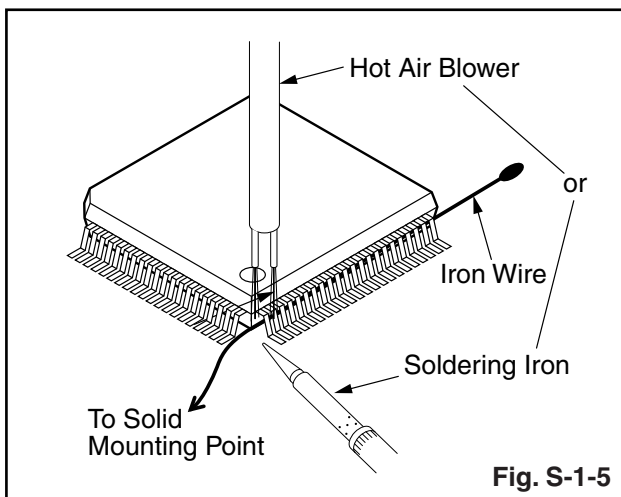

2. Installation

1. Using desoldering braid, remove the solder from the foil of each pin of the flat pack-IC on the CBA so you can install a replacement flat pack-IC more easily.
2. The "●" mark on the flat pack-IC indicates pin 1. (See Fig. S-1-7.) Be sure this mark matches the 1 on the PCB when positioning for installation. Then presolder the four corners of the flat pack-IC. (See Fig. S-1-8.)
3. Solder all pins of the flat pack-IC. Be sure that none of the pins have solder bridges.

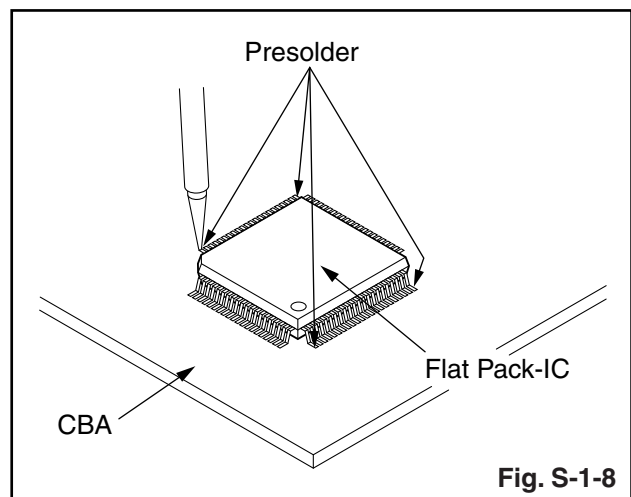
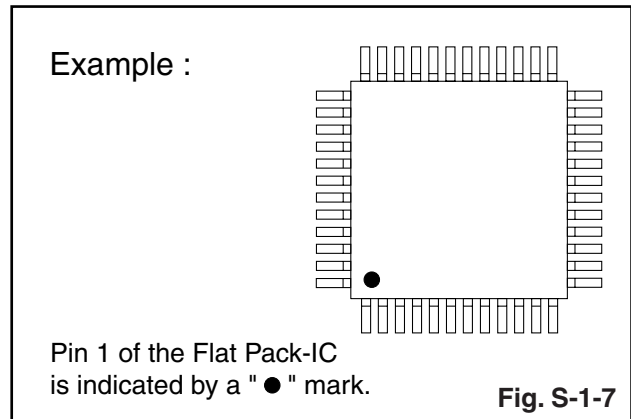

Instructions for Handling Semi-conductors

Electrostatic breakdown of the semi-conductors may occur due to a potential difference caused by electrostatic charge during unpacking or repair work.

1. Ground for Human Body

Be sure to wear a grounding band (1 M Ω) that is properly grounded to remove any static electricity that may be charged on the body.

2. Ground for Workbench

Be sure to place a conductive sheet or copper plate with proper grounding (1 M Ω) on the workbench or other surface, where the semi-conductors are to be placed. Because the static electricity charge on clothing will not escape through the body grounding band, be careful to avoid contacting semi-conductors with your clothing.

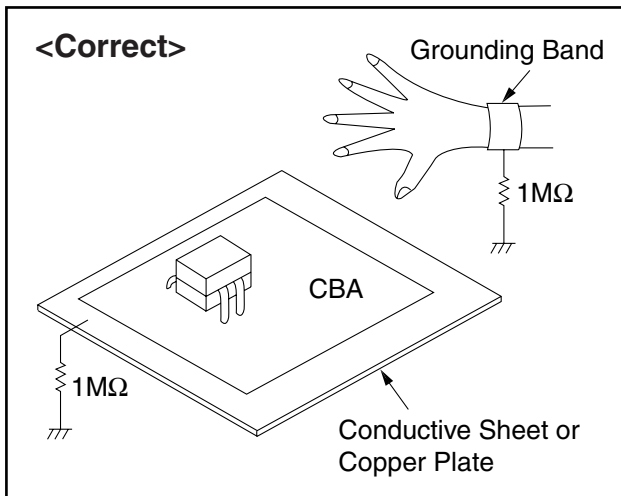
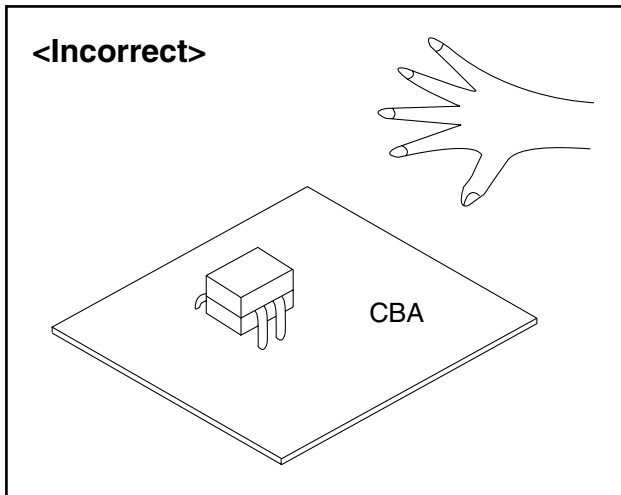

CABINET DISASSEMBLY INSTRUCTIONS

1. Disassembly Flowchart

This flowchart indicates the disassembly steps for the cabinet parts, and the CBA in order to gain access to item(s) to be serviced. When reassembling, follow the steps in reverse order. Bend, route and dress the cables as they were.

CAUTION!

When removing the CRT, be sure to discharge the Anode Lead of the CRT with the CRT Ground Wire before removing the Anode Cap.

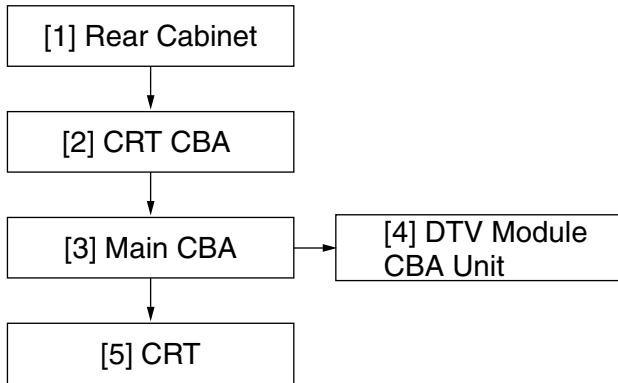

2. Disassembly Method

Step/ Loc. No.	Part	Removal		
		Fig. No.	Remove/*Unhook/ Unlock/Release/ Unplug/Unclamp/ Desolder	Note
[1]	Rear Cabinet	D1 D2	7(S-1), 2(S-2), (S-3)	1
[2]	CRT CBA	D4 D5	*CN1501	2
[3]	Main CBA	D3 D4 D5	*CN801, *CN802, *CN571, *CN691, Anode Cap	3
[4]	DTV Module CBA Unit	D3 D5	*CN901, *CN902, Module PCB Holder	4
[5]	CRT	D4	4(S-4)	5

↓ ↓ ↓ ↓ ↓
 (1) (2) (3) (4) (5)

Note:

- (1) Order of steps in procedure. When reassembling, follow the steps in reverse order. These numbers are also used as the Identification (location) No. of parts in figures.
- (2) Parts to be removed or installed.
- (3) Fig. No. showing procedure of part location
- (4) Identification of parts to be removed, unhooked, unlocked, released, unplugged, unclamped, or desoldered.
 P = Spring, L = Locking Tab, S = Screw,
 CN = Connector
 * = Unhook, Unlock, Release, Unplug, or Desolder
 e.g. 2(S-2) = two Screws (S-2),
 2(L-2) = two Locking Tabs (L-2)
- (5) Refer to the following "Reference Notes in the Table."

Reference Notes in the Table

1. Removal of the Rear Cabinet: Remove screws 7(S-1), 2(S-2) and (S-3) then slide the Rear Cabinet backward.
2. Removal of the CRT CBA: Disconnect CN1501 then pull the CRT CBA backward.
3. Removal of the Main CBA:
CAUTION: Discharge the Anode Lead of the CRT with the CRT Ground Wire before removing the Anode Cap.
 Disconnect CN801, CN802, CN571 and CN691 on the Main CBA and remove Anode Cap. Then slide the Main CBA backward.
4. Removal of the DTV Module CBA Unit: Remove Module PCB Holder and disconnect CN901 and CN902 on the DTV Module CBA Unit. Then remove the DTV Module CBA Unit.
5. Removal of the CRT: Remove screws 4(S-4). Then slide the CRT backward.

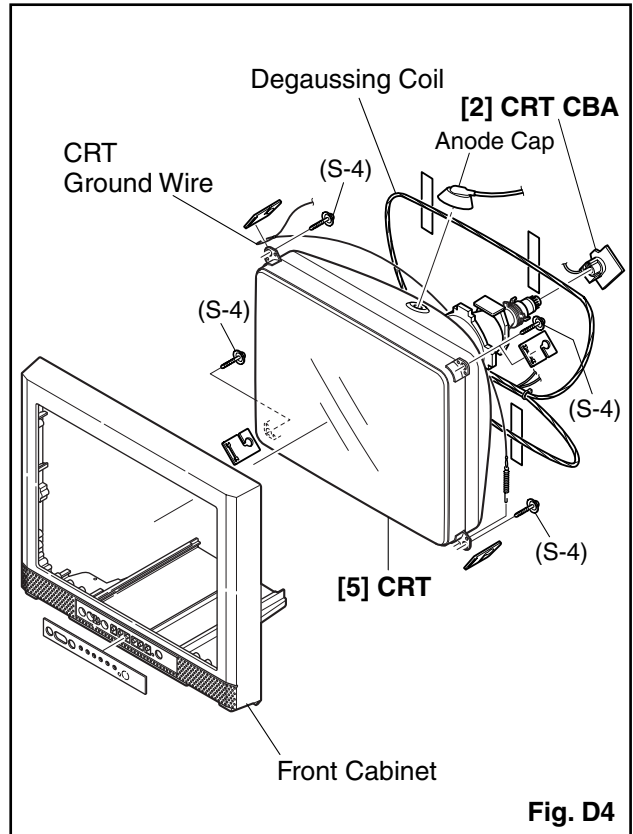
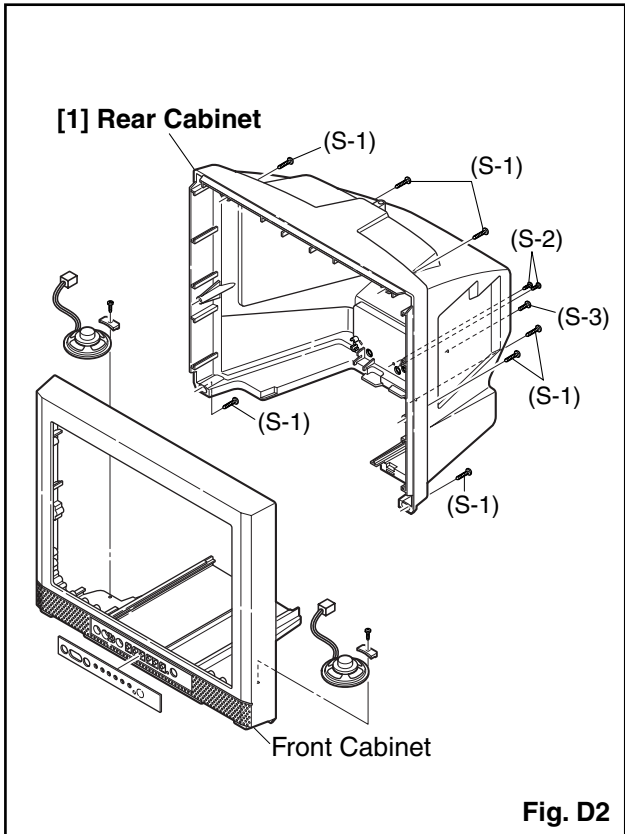
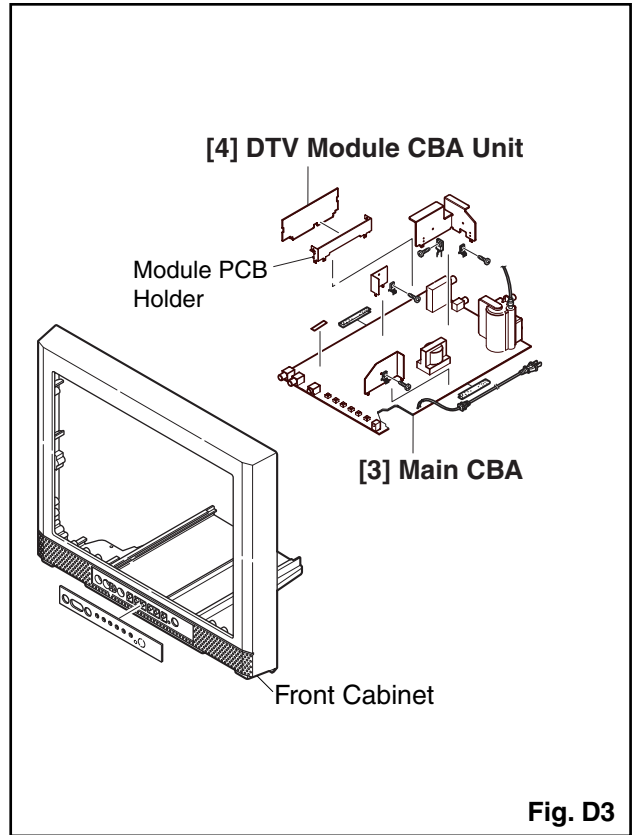
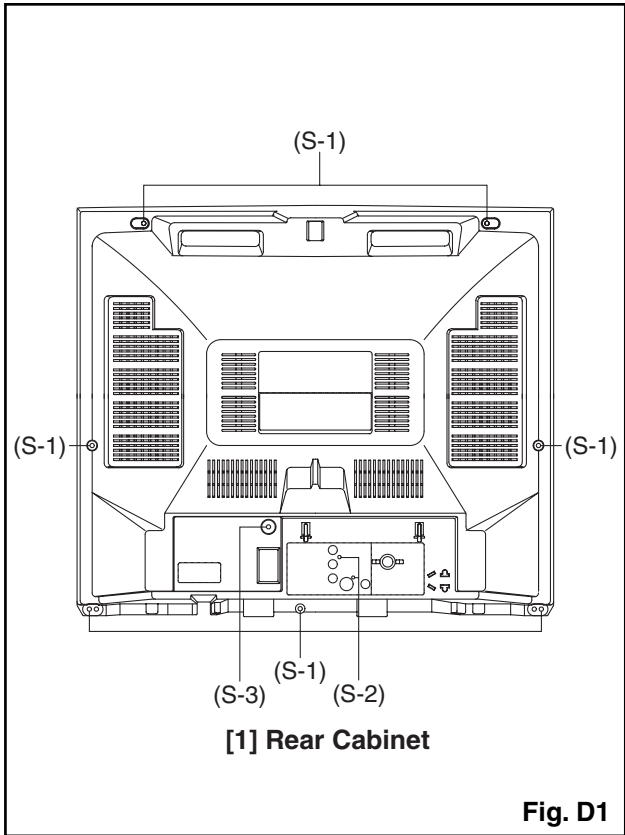

TV Cable Wiring Diagram

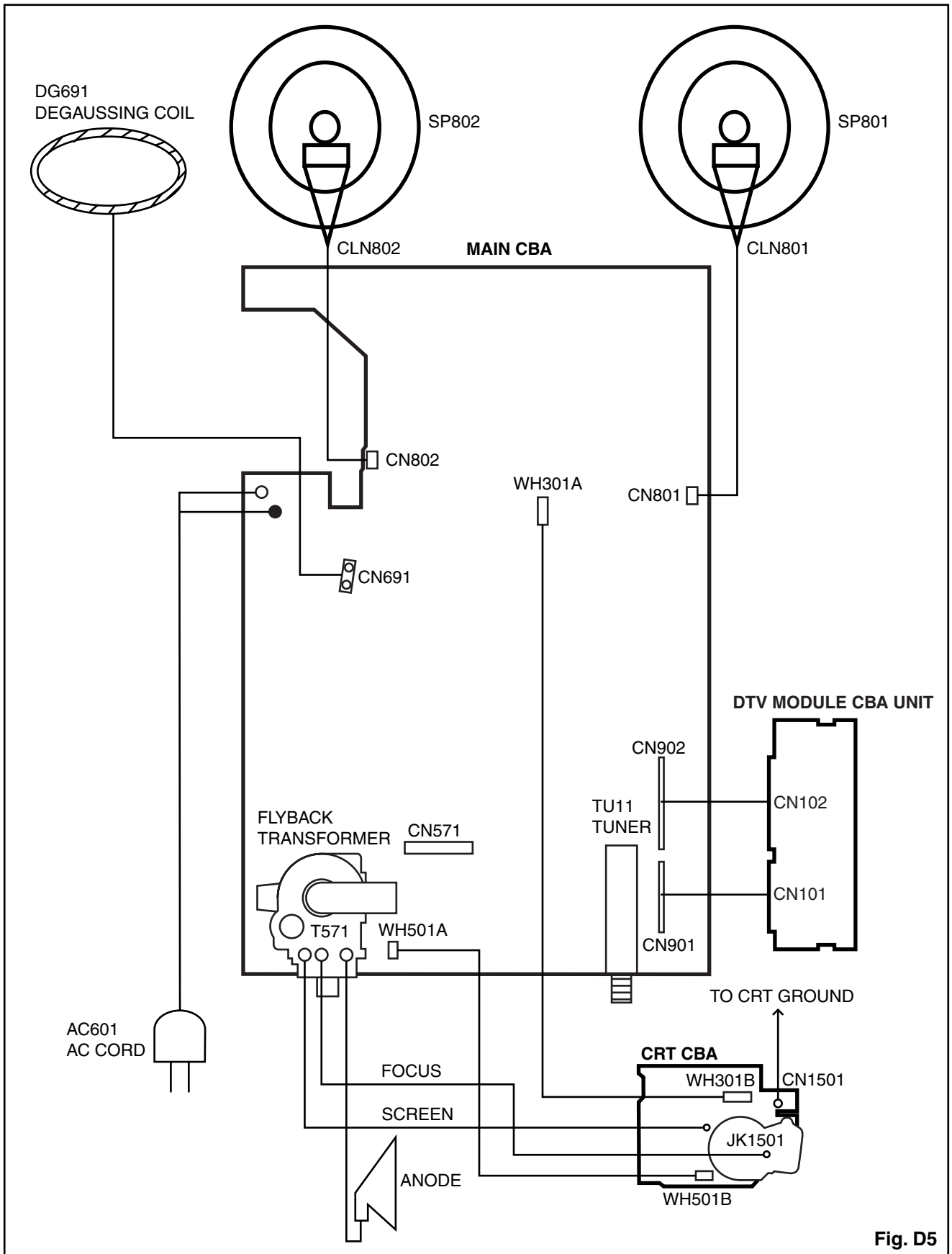

Fig. D5

ELECTRICAL ADJUSTMENT INSTRUCTIONS

General Note: “CBA” is abbreviation for “Circuit Board Assembly.”

Note: Electrical adjustments are required after replacing circuit components and certain mechanical parts. It is important to perform these adjustments only after all repairs and replacements have been completed. Also, do not attempt these adjustments unless the proper equipment is available.

Test Equipment Required

1. NTSC Pattern Generator (Color Bar W/White Window, Red Color, Dot Pattern, Gray Scale, Monoscope, Multi-Burst)
2. DC Voltmeter
3. Oscilloscope: Dual-trace with 10:1 probe, V-Range: 0.001~50 V/Div, F-Range: DC~AC-60 MHz
4. Plastic Tip Driver
5. Remote control unit: Part No. NE601UE
6. DC power supply 13.2V/5A

How to make Service remote control unit:

1. Prepare normal remote control unit. (Part No. NE601UE)
Remove 3 Screws from the back lid. (Fig. 1-1)

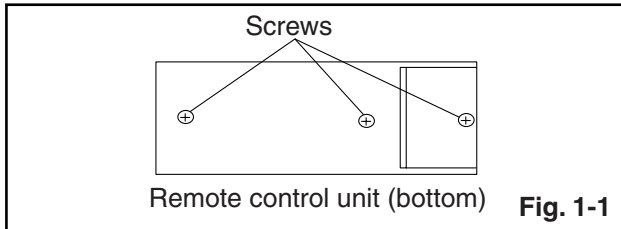

2. Add J1 (Jumper Wire) to the remote control CBA. (Fig. 1-2)

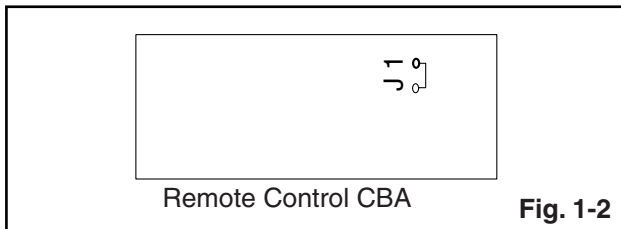

How to enter the service mode:

Service mode:

1. Use the service remote control unit.
2. Turn the power on. (Use main power on the TV unit.)
3. Press [SLEEP] button on the service remote control unit. Version of micro computer will display on the CRT. (Ex: 058-0.06)
4. Check the display on the lower left is “3641” and if it is not “3641,” set it at “3641” according to "Initial Setting" on page 5-2.

1. +B Adjustment

Purpose: To obtain correct operation.

Symptom of Misadjustment: The picture is dark and the unit does not operate correctly.

Test Point	Adj. Point	Mode	Input
TP601(+B) J095(GND)	VR661	---	---
Tape	M. EQ.	Spec.	
---	DC Voltmeter	+114±0.5 V DC.	

Note: TP601, J095(GND), VR661 --- Main CBA

1. Connect DC Volt Meter to TP601 and J095(GND).
2. Adjust VR661 so that the voltage of TP601 becomes +114±0.5 V DC.

2. Initial Setting

General

1. Enter the Service mode. (See page 5-1.)
2. Press [VOL ▽] button on the service remote control unit. Display changes “C/D,” “7F,” “SOUND TYPE,” “VIDEO,” “1000,” “YUV MEMORY,” “TUNER A/M/S,” “QAM,” “DTV-H,” “D-SOUND,” and “DL V-CHIP” cyclically when [VOL ▽] button is pressed.
3. To set the following each data value, press [CH ▲ / ▼] buttons on the service remote control unit.

7F --- Set to “FF.”

SOUND TYPE --- Set to “MONO.”

VIDEO --- Set to “V1/V2.”

1000 (monitoring time) --- Set to “1000.”

YUV MEMORY --- Set to “OFF.”

TUNER A/M/S --- Set it by indication of TUNER as follows

UTUNATSMS001: Set it in “M.”

UTUNATSSP001: Set it in “S.”

QAM --- Set to “135.”

DTV-H --- Set to “B.”

D-SOUND --- Set to “STEREO.”

DL V-CHIP --- Set to “ON.”

3. Setting for BRIGHT, CONTRAST, COLOR, S-COLOR, C-COLOR, TINT, V-TINT, S-TINT, C-TINT, SHARP, S-SHARP, and C-SHARP Data Values

General

1. Enter the Service mode. (See page 5-1.)
2. Press [MENU] button on the service remote control unit. Display changes “BRT,” “CNT,” “CLR,” “S-CLR,” “C-CLR,” “TNT,” “V-TNT,” “S-TNT,” “C-TNT,” “SHARP,” “S-SRP,” and “C-SRP,” cyclically when [MENU] button is pressed.

CNT

1. Press [MENU] button on the service remote control unit. Then select “CONTRAST” (CNT) display.
2. Press [CH ▲ / ▼] buttons on the service remote control unit so that the value of “CONTRAST” (CNT) becomes 84.

CLR

1. Press [MENU] button on the service remote control unit. Then select “COLOR” (CLR) display.

2. Press [CH ▲ / ▼] buttons on the service remote control unit so that the value of “COLOR” (CLR) becomes 58.

S-CLR

1. Press [MENU] button on the service remote control unit. Then select “S-COLOR” (S-CLR) display.
2. Press [CH ▲ / ▼] buttons on the service remote control unit so that the value of “S-COLOR” (S-CLR) becomes 58.

C-CLR

1. Press [MENU] button on the service remote control unit. Then select “C-COLOR” (C-CLR) display.
2. Press [CH ▲ / ▼] buttons on the service remote control unit so that the value of “C-COLOR” (C-CLR) becomes 66.

TNT

1. Press [MENU] button on the service remote control unit. Then select “TINT” (TNT) display.
2. Press [CH ▲ / ▼] buttons on the service remote control unit so that the value of “TINT” (TNT) becomes 54.

V-TNT

1. Press [MENU] button on the service remote control unit. Then select “V-TINT” (V-TNT) display.
2. Press [CH ▲ / ▼] buttons on the service remote control unit so that the value of “V-TINT” (V-TNT) becomes 58.

S-TNT

1. Press [MENU] button on the service remote control unit. Then select “S-TINT” (S-TNT) display.
2. Press [CH ▲ / ▼] buttons on the service remote control unit so that the value of “S-TINT” (S-TNT) becomes 58.

C-TNT

1. Press [MENU] button on the service remote control unit. Then select “C-TINT” (C-TNT) display.
2. Press [CH ▲ / ▼] buttons on the service remote control unit so that the value of “C-TINT” (C-TNT) becomes 59.

SHARP

1. Press [MENU] button on the service remote control unit. Then select “SHARP” (SHARP) display.
2. Press [CH ▲ / ▼] buttons on the service remote control unit and select “43.”

S-SRP

1. Press [MENU] button on the service remote control unit. Then select “S-SHARP” (S-SRP) display.

- Press [CH ▲ / ▼] buttons on the service remote control unit and select "40."

C-SRP

- Press [MENU] button on the service remote control unit. Then select "C-SHARP" (C-SRP) display.
- Press [CH ▲ / ▼] buttons on the service remote control unit and select "40."

Note: BRIGHT data value does not need to be adjusted at this moment.

4. H f₀ Adjustment

Purpose: To get correct horizontal frequency.

Note: Use service remote control unit.

- Press [2] button on the service remote control unit and select H-ADJ mode. (By pressing [2] button the display will change from TV AGC to H-ADJ.)
- Press [CH ▲ / ▼] buttons on the service remote control unit so that display will change "0" ~ "7". At this moment, Choose "4".
- Turn the power off and on again. (Main Power button on the TV unit.)

5. Black Stretch Control Adjustment

Purpose: To show the fine black color.

Symptom of Misadjustment: Black color will not appear correctly.

Note: Use service remote control unit.

- Enter the Service mode. (See page 5-1.)
- Press [0] button on the service remote control unit. "B-S" is indicated.
- Press [CH ▲ / ▼] buttons on the service remote control unit so that display will change "OFF," "0," and "1." Then choose "B-S OFF."
- Press [0] button on the service remote control unit. "B-S2" is indicated.
- Press [CH ▲ / ▼] buttons on the service remote control unit so that display will change "0" and "1." Then choose "B-S2 0."
- Turn the power off and on again, using the main power button on the TV unit.

6. Purity Check

- Enter the Service mode. (See page 5-1.)
- Press [7] button on the remote control unit. Each time pressing [7] button on the service remote control unit, display changes Red mode, Green mode, Blue mode, and White mode cyclically.
- Select White mode.
- Turn the power off and on again. (Main power button on the TV unit.)

7. SD Check Mode

- Enter the Service mode. (See page 5-1.)
- Press [1] button on the remote control unit. The unit enters the SD-Check mode.
- The unit starts selecting the added channel from the first channel according to the memorized CH ADD/DEL data and CATV/TV data in RAM.

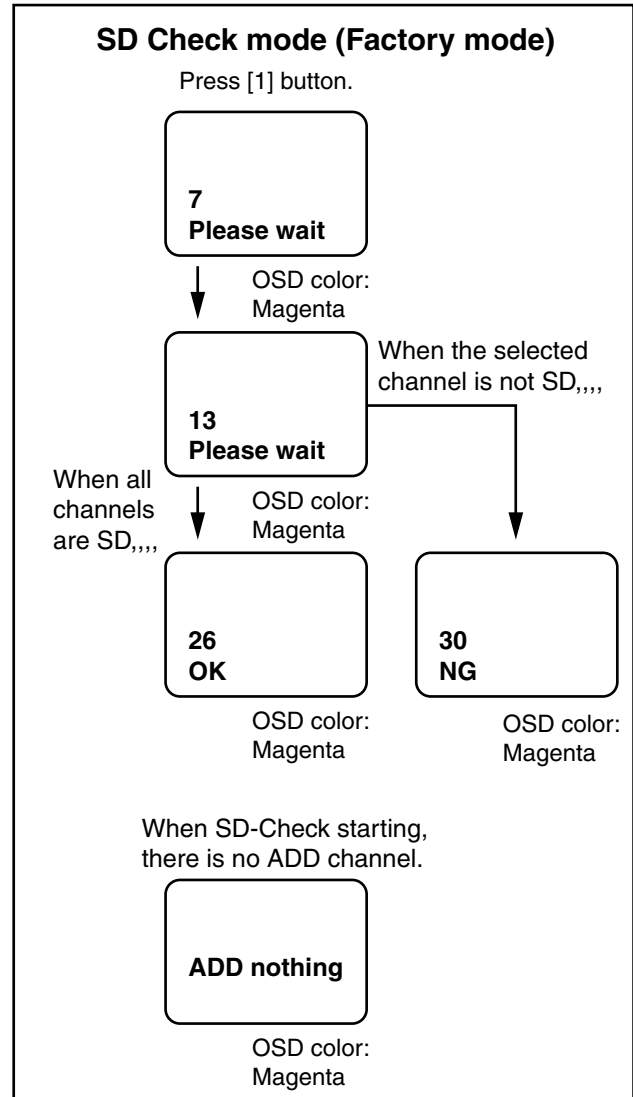

8. H. Position Adjustment

Purpose: To obtain correct horizontal position of screen image.

Symptom of Misadjustment: If H. Position is incorrect, horizontal position of image on the screen may not be properly displayed.

Test Point	Adj. Point	Mode	Input
---	[CH ▲ / ▼] buttons	RF	Monoscope
Tape	M. EQ.	Spec.	
---	Monoscope	90±5%	

Note: Use service remote control unit

1. Operate the unit for at least 20 minutes.
2. Enter the Service mode. (See page 5-1.)
3. Receive the monoscope pattern.
4. Press [8] button on the remote control unit. "H-P" is indicated.
5. Press [CH ▲ / ▼] buttons on the service remote control unit so that the monoscope pattern will be 90±5% of display size and the circle is round.
6. Turn the power off and on again. (Main power button on the TV unit.)

9. V. Size Adjustment

Purpose: To obtain correct vertical width of screen image.

Symptom of Misadjustment: If V. Size is incorrect, vertical size of image on the screen may not be properly displayed.

Test Point	Adj. Point	Mode	Input
---	[CH ▲ / ▼] buttons	RF	Monoscope
Tape	M. EQ.	Spec.	
---	Monoscope	90±5%	

Note: Use service remote control unit.

1. Operate the unit for at least 20 minutes.
2. Enter the Service mode. (See page 5-1.)
3. Receive the monoscope pattern.
4. Press [9] button on the service remote control unit and select "V-S" mode. (Display changes "V-S" and "V-P" cyclically when [9] button is pressed).
5. Press [CH ▲ / ▼] buttons on the service remote control unit so that the monoscope pattern will be 90±5% of display size and the circle is round.
6. Turn the power off and on again. (Main power button on the TV unit.)

10. V. Position Adjustment

Purpose: To obtain correct vertical width of screen image.

Symptom of misadjustment: If V. Position is incorrect, vertical height of image on the screen may not be properly displayed.

Test Point	Adj. Point	Mode	Input
---	[CH ▲ / ▼] buttons	RF	Monoscope
Tape	M. EQ.	Spec.	
---	Monoscope	See below.	

Note: Use service remote control unit

1. Operate the unit for at least 20 minutes.
2. Enter the Service mode. (See page 5-1.)
3. Receive the monoscope pattern.
4. Press [9] button on the service remote control unit and select "V-P" mode. (Display changes "V-S" and "V-P" cyclically when [9] button is pressed).
5. Press [CH ▲ / ▼] buttons on the service remote control unit so that the top and bottom of the monoscope pattern will be equal each other.
6. Turn the power off and on again. (Main power button on the TV unit.)

11. Software Reset

To reset software, press [5] button on the remote control unit for at least 5 seconds after pressing [CH RETURN] button on the remote control unit.

12. Cut-off Adjustment

Purpose: To adjust the beam current of R, G, B, and screen voltage.

Symptom of Misadjustment: White color may be reddish, greenish or bluish.

Test Point	Adj. Point	Mode	Input
---	Screen-Control [CH ▲ / ▼] buttons	RF	Black Raster
Tape	M. EQ.	Spec.	
---	Pattern Generator	See Reference Notes below.	
Figure			
			

Fig. 2

Note: Screen Control FBT --- Main CBA
FBT = Fly Back Transformer
Use service remote control unit

- Degauss the CRT and allow CRT to operate for 20 minutes before starting the alignment.
- Input the Black Raster Signal from RF Input.
- Enter the Service mode. (See page 5-1.)
- Press [VOL ▼] button on the service remote control unit and select "C/D" mode. (Display changes "C/D," "7F," "SOUND TYPE," "VIDEO," "1000," "YUV MEMORY," "TUNER A/M/S," "QAM," "DTV-H," "D-SOUND," and "DL V-CHIP" cyclically when [VOL ▼] button is pressed.) then press "1." The display will momentarily show "CUT OFF R" (R= Red). Now there should be a horizontal line across the center of the picture tube. If needed, turn the screen control on the flyback in a clockwise direction gradually until the horizontal line appears. Adjust the Red Cut off by pressing [CH ▲ / ▼] buttons. Proceed to Step 5 when the Red Cut off adjustment is done.
- Press [2] button. The display will momentarily show "CUT OFF G" (G = Green). Adjust the Green Cut off by pressing [CH ▲ / ▼] buttons. Proceed to step 6 when the Green Cut off adjustment is done.

- Press [3] button. The display will momentarily show "CUT OFF B" (B = Blue). Adjust the Blue cut off by pressing [CH ▲ / ▼] buttons. When done with steps 4, 5 and 6 the horizontal line should be pure white, if not, then attempt the Cut off adjustment again.

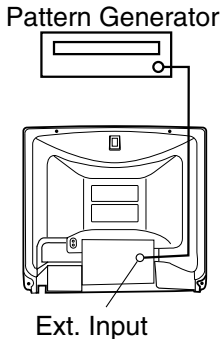
13. White Balance Adjustment

Purpose: To mix red, green and blue beams correctly for pure white.

Symptom of Misadjustment: White becomes bluish or reddish.

Test Point	Adj. Point	Mode	Input
Screen	[CH ▲ / ▼] buttons	RF	White Raster (APL 100%)
Tape	M. EQ.	Spec.	
---	Pattern Generator, Color Analyzer	See below	
Figure			
			

Fig. 3

Note: Use service remote control unit

- Operate the unit more than 20 minutes.
- Face the unit to east. Degauss the CRT using Degaussing Coil.
- Input the White Raster (APL 100%).
- Set the color analyzer to the CHROMA mode and after zero point calibration, bring the optical receptor to the center on the tube surface (CRT).
- Enter the Service mode. (See page 5-1.) Press [VOL ▼] button on the service remote control unit and select "C/D" mode. (Display changes "C/D," "7F," "SOUND TYPE," "VIDEO," "1000," "YUV MEMORY," "TUNER A/M/S," "QAM," "DTV-H," "D-SOUND," and "DL V-CHIP" cyclically when [VOL ▼] button is pressed). Then press [8] button on the service remote control unit.
- Press [4] button on the service remote control unit for Red adjustment. Press [5] button on the service remote control unit for Blue adjustment.
- In each color mode, Press [CH ▲ / ▼] buttons to adjust the values of color.

8. Adjust Red and Blue color so that the temperature becomes 9200K (x: 286 / y: 294)±3%.
9. At this time, Re-check if Horizontal line is white. If not, Re-adjust Cut-off Adjustment until the Horizontal Line becomes pure white.
10. Turn off and on again to return to the normal mode. Receive APL 100% white signal and Check Chroma temperatures become 9200K (x: 286 / y: 294)±3%.

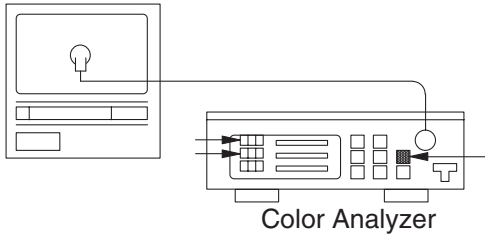
Note: Confirm that Cut Off Adj. is correct after this adjustment, and attempt Cut Off Adj, if needed.

14. YUV Pedestal Adjustment

Purpose: To adjust the pedestal level of YUV input.

Test Point	Adj. Point	Mode	Input
Screen	[CH ▲ / ▼] buttons	DTV	---
Tape	M. EQ.	Spec.	
---	Color Analyzer	See below	

Figure

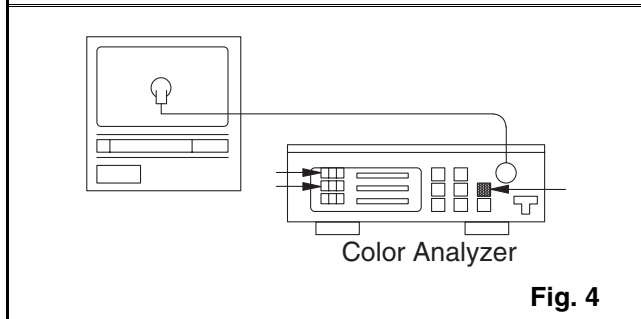

Fig. 4

1. Enter the Service mode in DTV mode.
2. Press [3] button on the service remote control unit. The screen changes white 50% automatically. (Display changes "U-PED" and "Y-PED" cyclically when [3] button is pressed).
3. Press [CH ▲ / ▼] buttons on the service remote control unit so that the Chroma temperature becomes 9200K ±3%.

15. Sub-Brightness Adjustment

Purpose: To get proper brightness.

Symptom of Misadjustment: If Sub-Brightness is incorrect, proper brightness cannot be obtained by adjusting the Brightness Control.

Test Point	Adj. Point	Mode	Input
---	[CH ▲ / ▼] buttons	RF	IQW
Tape	M. EQ.	Spec.	
---	Pattern Generator	See below	

Figure

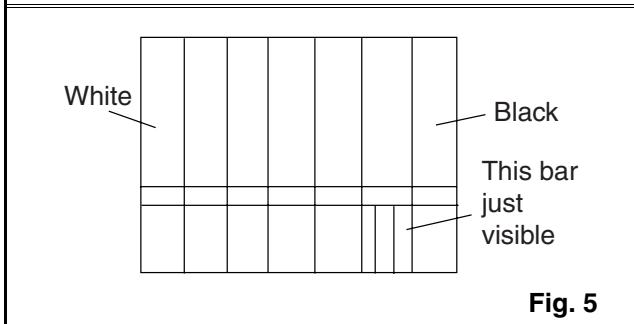

Note: IQW Setup level --- 7.5 IRE

Use service remote control unit

1. Enter the Service mode. (See page 5-1.) Then input IQW signal from RF Input.
2. Press [MENU] button on the service remote control unit and Select "BRT" mode. (Display changes "BRT," "CNT," "CLR," "S-CLR," "C-CLR," "TNT," "V-TNT," "S-TNT," "C-TNT," "SHARP," "S-SRP," and "C-SRP," cyclically when [MENU] button is pressed). Press [CH ▲ / ▼] buttons so that the bar is just visible (See above figure).
3. Turn the power off and on again. (Main power button on the TV unit.)

16. Focus Adjustment

Purpose: Set the optimum Focus.

Symptom of Misadjustment: If Focus Adjustment is incorrect, blurred images are shown on the display.

Test Point	Adj. Point	Mode	Input
---	Focus Control	---	Monoscope
Tape	M. EQ.	Spec.	
---	Pattern Generator	See below	

Note: Focus VR (FBT) --- Main CBA,
FBT = Fly Back Transformer

1. Operate the unit more than 30 minutes.

2. Face the unit to the East and Degauss the CRT using Degaussing Coil.
3. Input the Monoscope Pattern.
4. Adjust the Focus Control on the FBT to obtain clear picture.

The following adjustments normally are not attempted in the field. Only when replacing the CRT then adjust as a preparation.

17. Purity Adjustment

Purpose: To obtain pure color.

Symptom of Misadjustment: If Color Purity Adjustment is incorrect, large areas of color may not be properly displayed.

Test Point	Adj. Point	Mode	Input
---	Deflection Yoke Purity Magnet	---	Red Color
Tape	M. EQ.	Spec.	
---	Pattern Generator	See below	
Figure			
			

Fig. 6

1. Set the unit facing east.
2. Operate the unit for over 30 minutes before adjusting.
3. Fully degauss the unit using an external degaussing coil.
4. Loosen the screw on the Deflection Yoke Clamper and pull the Deflection Yoke back away from the screen. (See Fig. 7)
5. Loosen the Ring Lock and adjust the Purity Magnets so that a red field is obtained at the center of the screen. Tighten Ring Lock. (See Fig. 6,7)
6. Slowly push the Deflection Yoke toward the bell of CRT and set it where a uniform red field is obtained.
7. Tighten the clamp screw on the Deflection Yoke.

18. Convergence Adjustment

Purpose: To obtain proper convergence of red, green and blue beams.

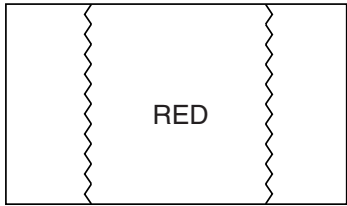
Symptom of Misadjustment: If Convergence Adjustment is incorrect, the edge of white letters may have color edges.

Test Point	Adj. Point	Mode	Input
---	C.P. Magnet (RB) C.P. Magnet (RB-G) Deflection Yoke	---	Dot Pattern or Crosshatch
Tape	M. EQ.	Spec.	
---	Pattern Generator	See below	

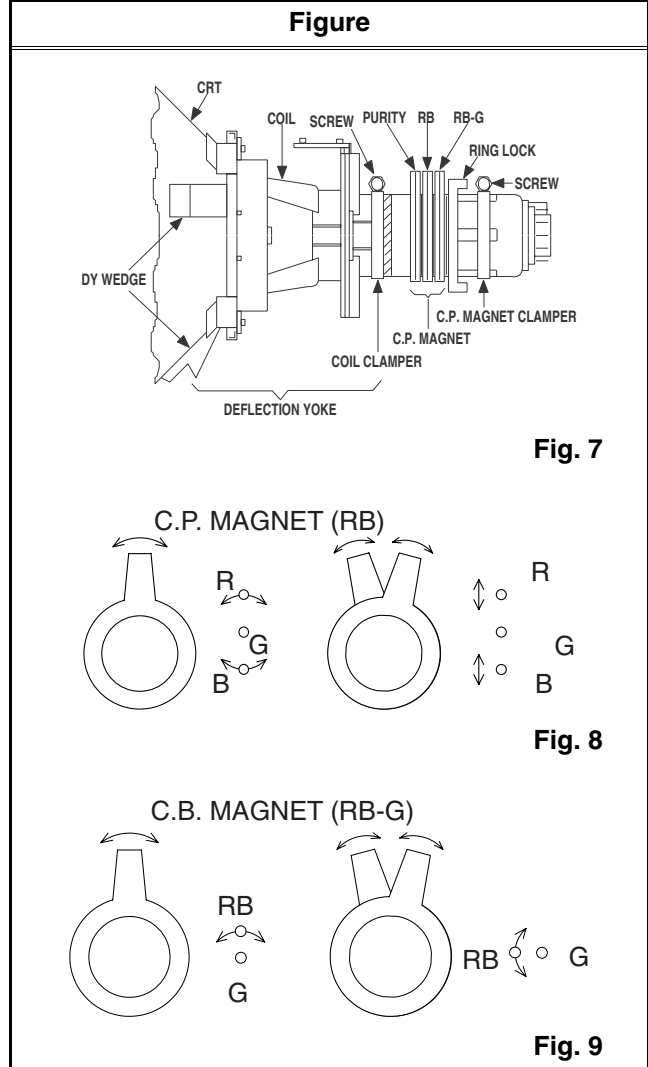

1. Loosen the Ring Lock and align red with blue dots or Crosshatch at the center of the screen by rotating (RB) C.P. Magnets. (See Fig. 8)
2. Align red / blue with green dots at the center of the screen by rotating (RB-G) C.P. Magnet. (See Fig. 9)
3. Paintlock the C.P. Magnets after adjustment.

4. Remove the DY Wedges and slightly tilt the Deflection Yoke horizontally and vertically to obtain the best overall convergence.
5. Fix the Deflection Yoke by carefully inserting the DY Wedges between CRT and Deflection Yoke.

HOW TO INITIALIZE THE TELEVISION

To put the program back at the factory-default, initialize the television as the following procedure.

1. Use the service remote control unit.
2. Turn the power on. (Use main power on the TV unit.)
3. Press [SLEEP] button on the service remote control unit to enter the Service mode. (Refer to "How to enter the Service mode" on page 5-1.)
4. Press [VOL ▽] button on the service remote control unit twice, and confirm that OSD indication is "7F = FF." If needed, set it to become "7F = FF" by pressing [CH ▲ / ▼] buttons on the service remote control unit.
5. Confirm that OSD indication on the four corners on TV screen changes from on and off light indication to red by pressing a [DISPLAY] button. (It takes one or two seconds.)
6. Turn the power off by pressing main power button on the TV unit, and unplug the AC cord from the AC outlet.

BLOCK DIAGRAMS

System Control Block Diagram

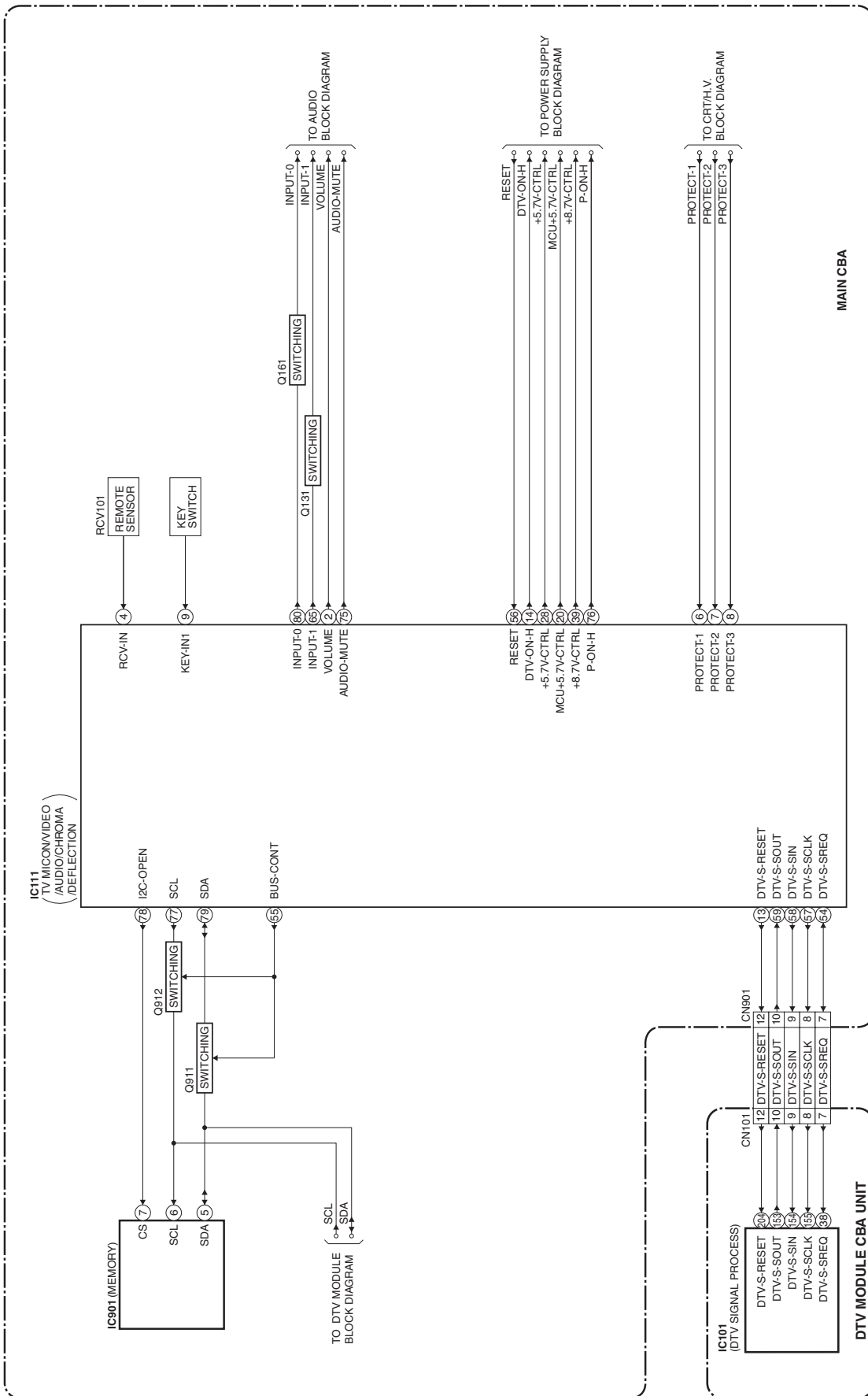

IF/Video Block Diagram

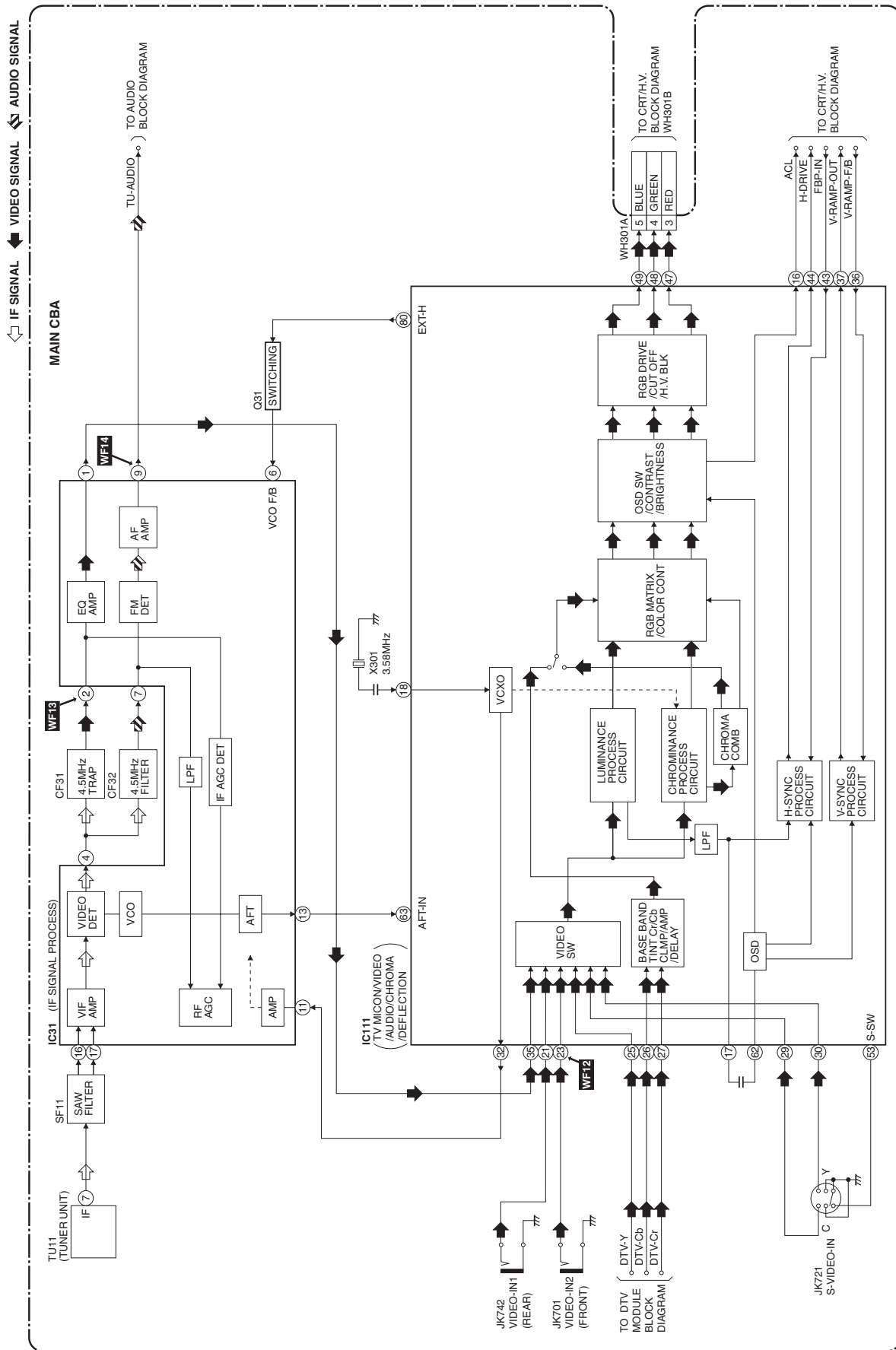

Audio Block Diagram

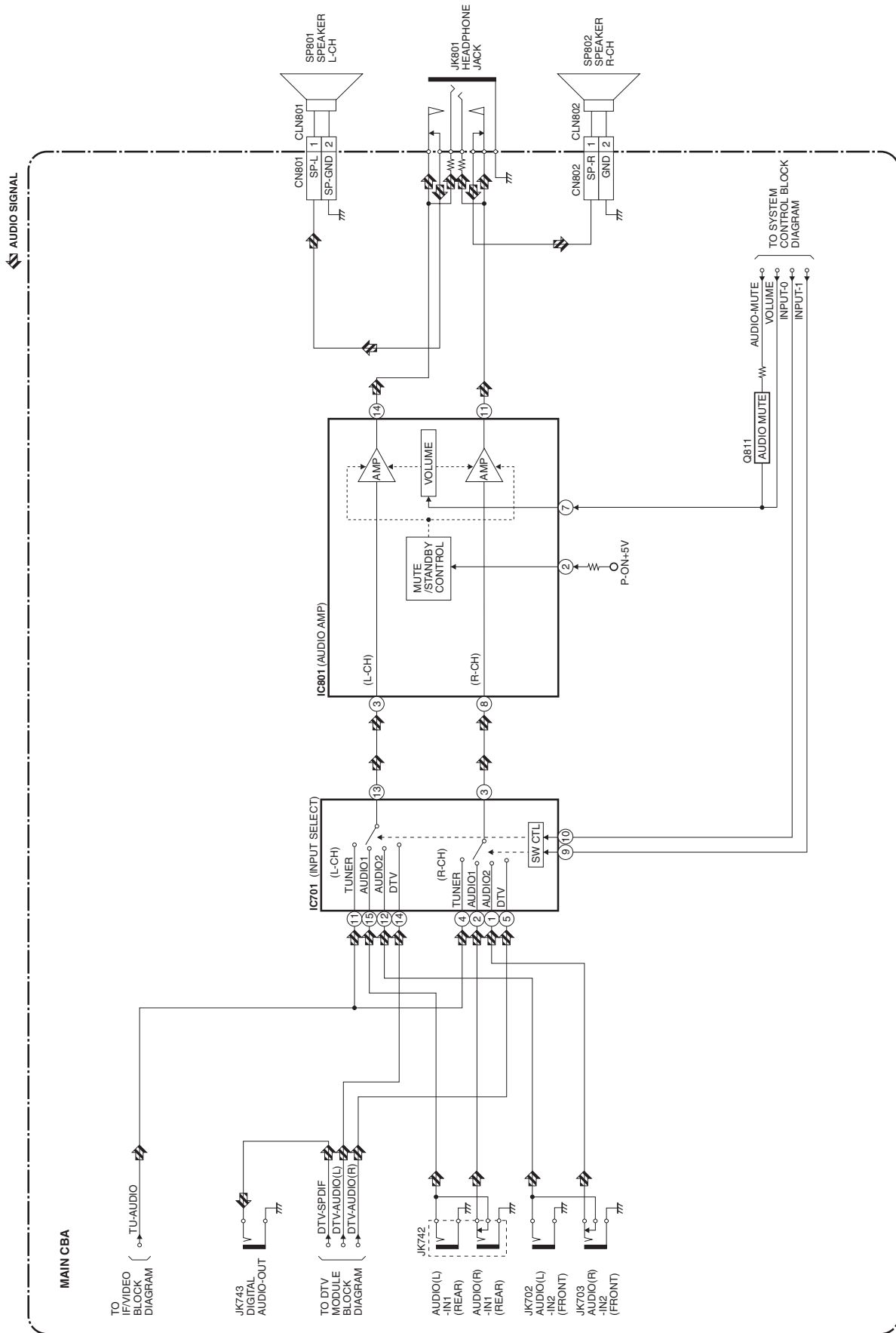

DTV Module Block Diagram

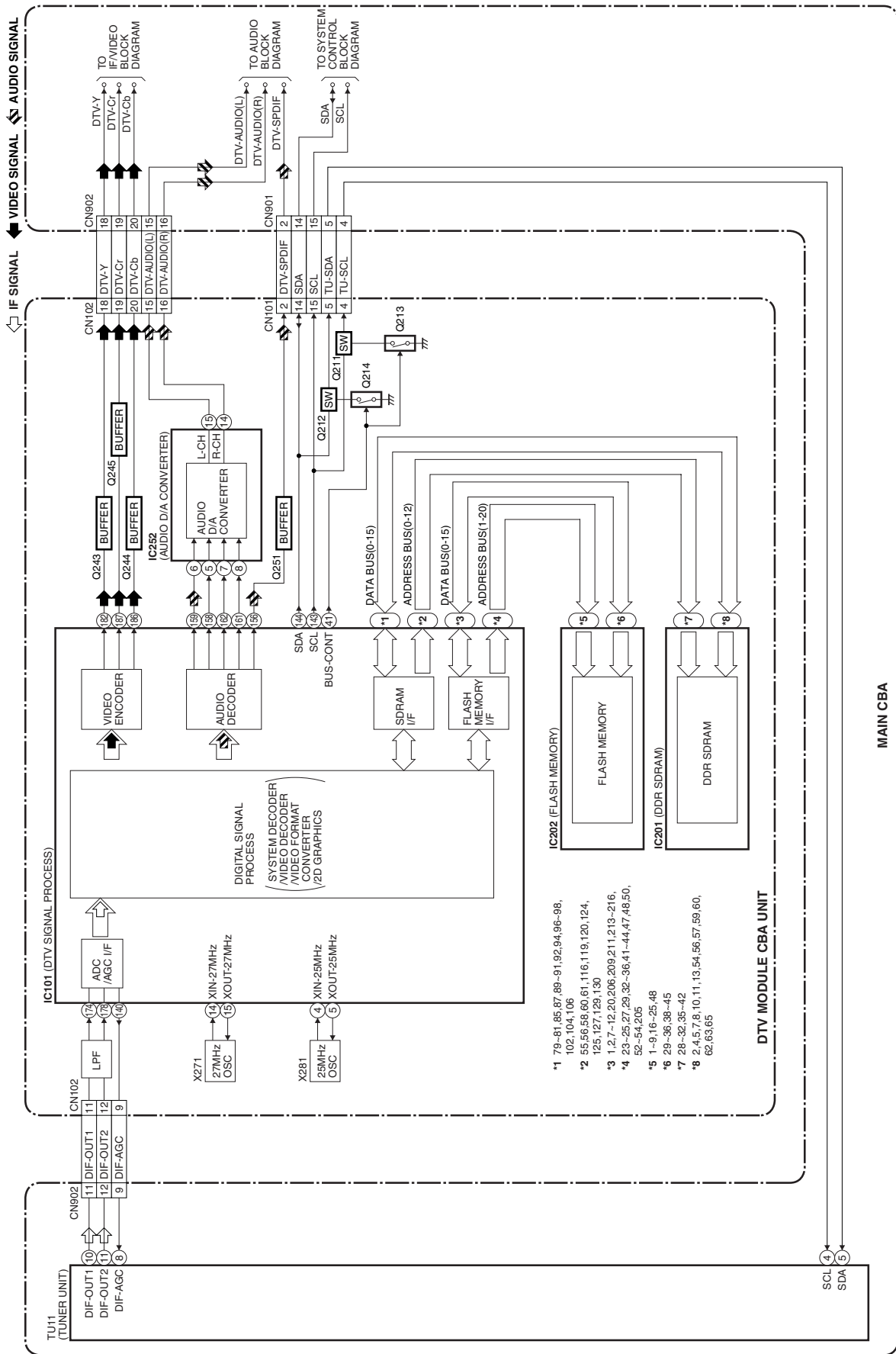

CRT/H.V. Block Diagram

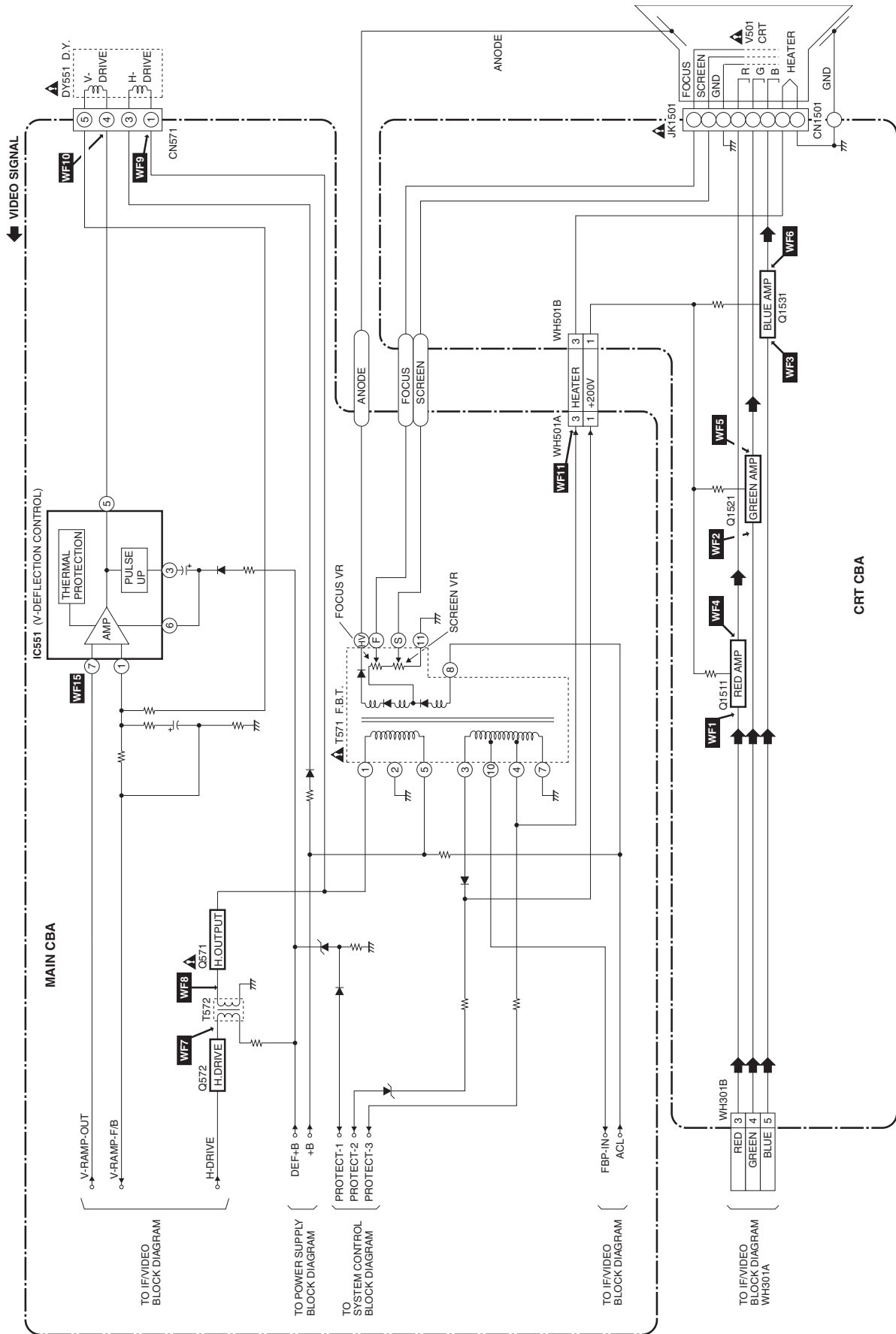

Power Supply Block Diagram

CAUTION !

Fixed voltage (or Auto voltage selectable) power supply circuit is used in this unit. If Main Fuse (F601) is blown, check to see that all components in the power supply circuit are not defective before you connect the AC plug to the AC power supply. Otherwise it may cause some components in the power supply circuit to fail.



CAUTION ! : For continued protection against risk of fire, replace only with same type 4 A, 125V fuse.
ATTENTION : Utiliser un fusible de rechange de même type de 4A, 125V.

NOTE: The voltage for parts in hot circuit is measured using hot GND as a common terminal.

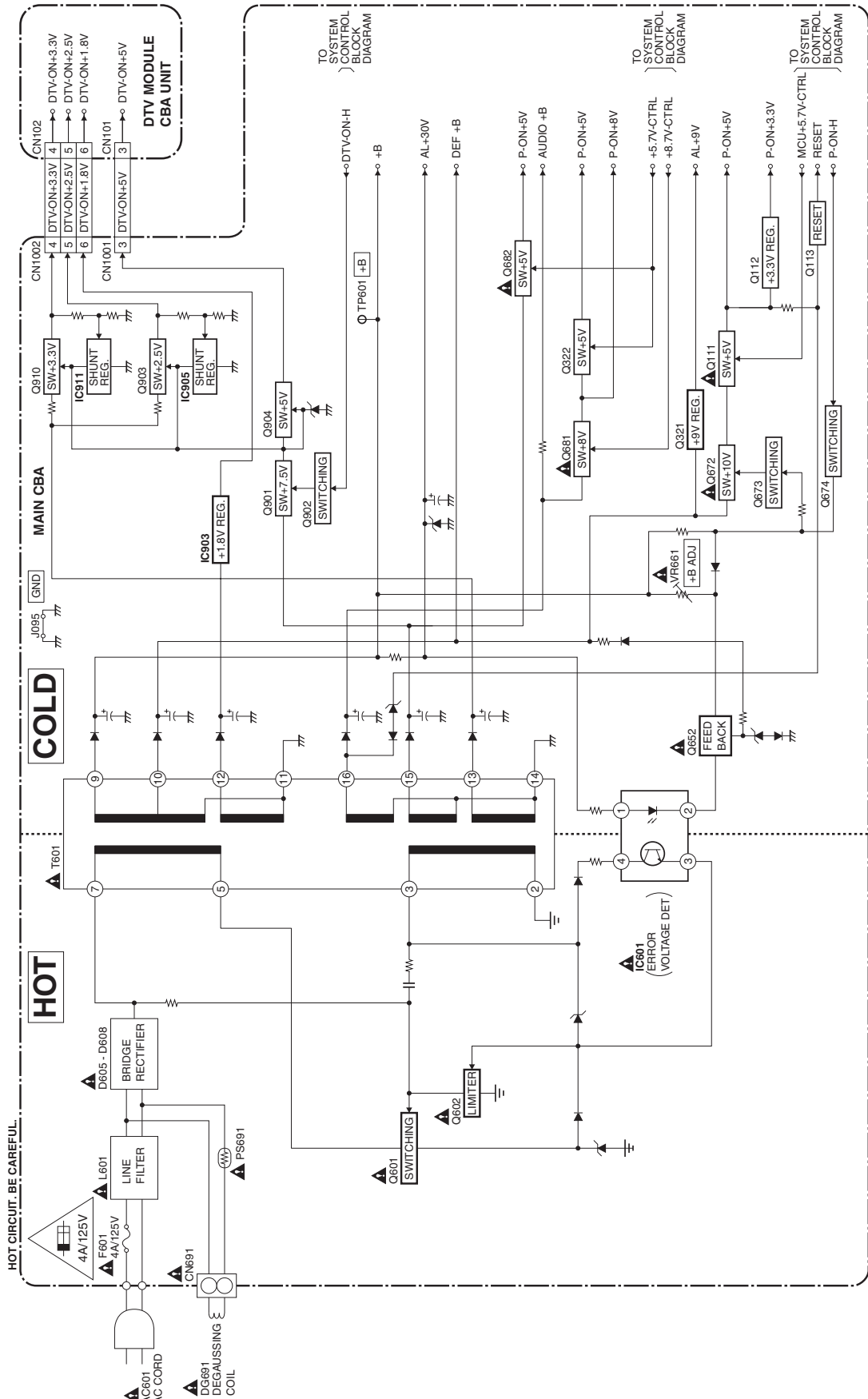

SCHEMATIC DIAGRAMS / CBA'S AND TEST POINTS

Standard Notes

Many electrical and mechanical parts in this chassis have special characteristics. These characteristics often pass unnoticed and the protection afforded by them cannot necessarily be obtained by using replacement components rated for higher voltage, wattage, etc. Replacement parts that have these special safety characteristics are identified in this manual and its supplements; electrical components having such features are identified by the mark “▲” in the schematic diagram and the parts list. Before replacing any of these components, read the parts list in this manual carefully. The use of substitute replacement parts that do not have the same safety characteristics as specified in the parts list may create shock, fire, or other hazards.

Notes:

1. Do not use the part number shown on these drawings for ordering. The correct part number is shown in the parts list, and may be slightly different or amended since these drawings were prepared.
2. All resistance values are indicated in ohms ($K = 10^3$, $M = 10^6$).
3. Resistor wattages are 1/4W or 1/6W unless otherwise specified.
4. All capacitance values are indicated in μF ($P = 10^{-6} \mu F$).
5. All voltages are DC voltages unless otherwise specified.

Note of Capacitors:

ML --- Mylar Cap. PP --- Metallized Film Cap. SC --- Semiconductor Cap. L --- Low Leakage type

Temperature Characteristics of Capacitors are noted with the following:

B --- $\pm 10\%$ CH --- 0 ± 60 ppm/ $^{\circ}C$ CSL --- $+350 \sim 1000$ ppm/ $^{\circ}C$

Tolerance of Capacitors are noted with the following:

Z --- $+80 \sim 20\%$

Note of Resistors:

CEM --- Cement Res. MTL --- Metal Res. F --- Fuse Res.

Capacitors and transistors are represented by the following symbols.

CBA Symbols

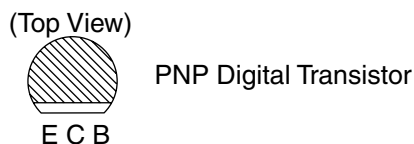
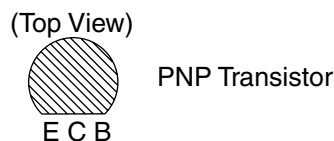
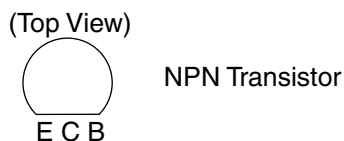
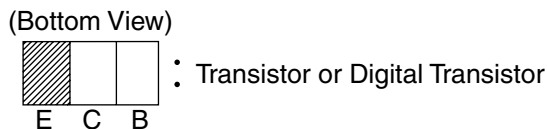
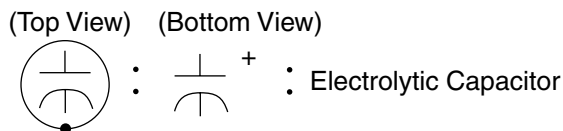

Schematic Diagram Symbols

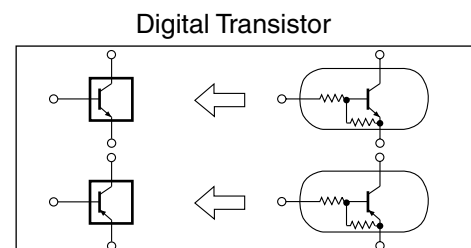

LIST OF CAUTION, NOTES, AND SYMBOLS USED IN THE SCHEMATIC DIAGRAMS ON THE FOLLOWING PAGES:

1. CAUTION:

CAUTION: FOR CONTINUED PROTECTION AGAINST RISK OF FIRE, REPLACE ONLY WITH SAME TYPE_A,_V FUSE.

ATTENTION: UTILISER UN FUSIBLE DE RECHANGE DE MÊME TYPE DE_A,_V.

2. CAUTION:

Fixed Voltage (or Auto voltage selectable) power supply circuit is used in this unit.

If Main Fuse (F601) is blown, first check to see that all components in the power supply circuit are not defective before you connect the AC plug to the AC power supply. Otherwise it may cause some components in the power supply circuit to fail.

3. Note:

- Do not use the part number shown on the drawings for ordering. The correct part number is shown in the parts list, and may be slightly different or amended since the drawings were prepared.
- To maintain original function and reliability of repaired units, use only original replacement parts which are listed with their part numbers in the parts list section of the service manual.

4. Voltage indications on the schematics are as shown below:

Plug the TV power cord into a standard AC outlet.:

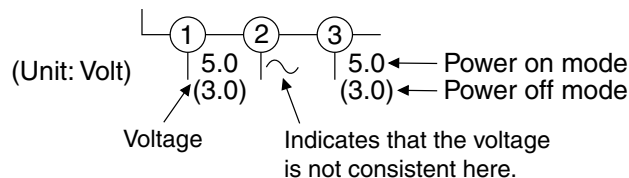

5. How to read converged lines

1-D3
 Distinction Area
 Line Number
 (1 to 3 digits)

Examples:

- "1-D3" means that line number "1" goes to the line number "1" of the area "D3".
- "1-B1" means that line number "1" goes to the line number "1" of the area "B1".

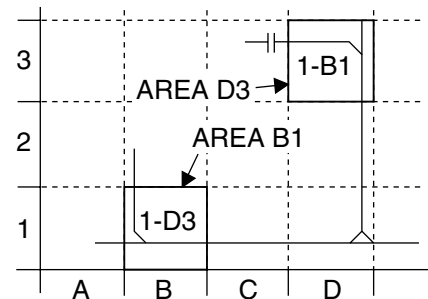

6. Test Point Information

- : Indicates a test point with a jumper wire across a hole in the PCB.
- : Used to indicate a test point with a component lead on foil side.
- : Used to indicate a test point with no test pin.
- : Used to indicate a test point with a test pin.

Main 1/4 Schematic Diagram

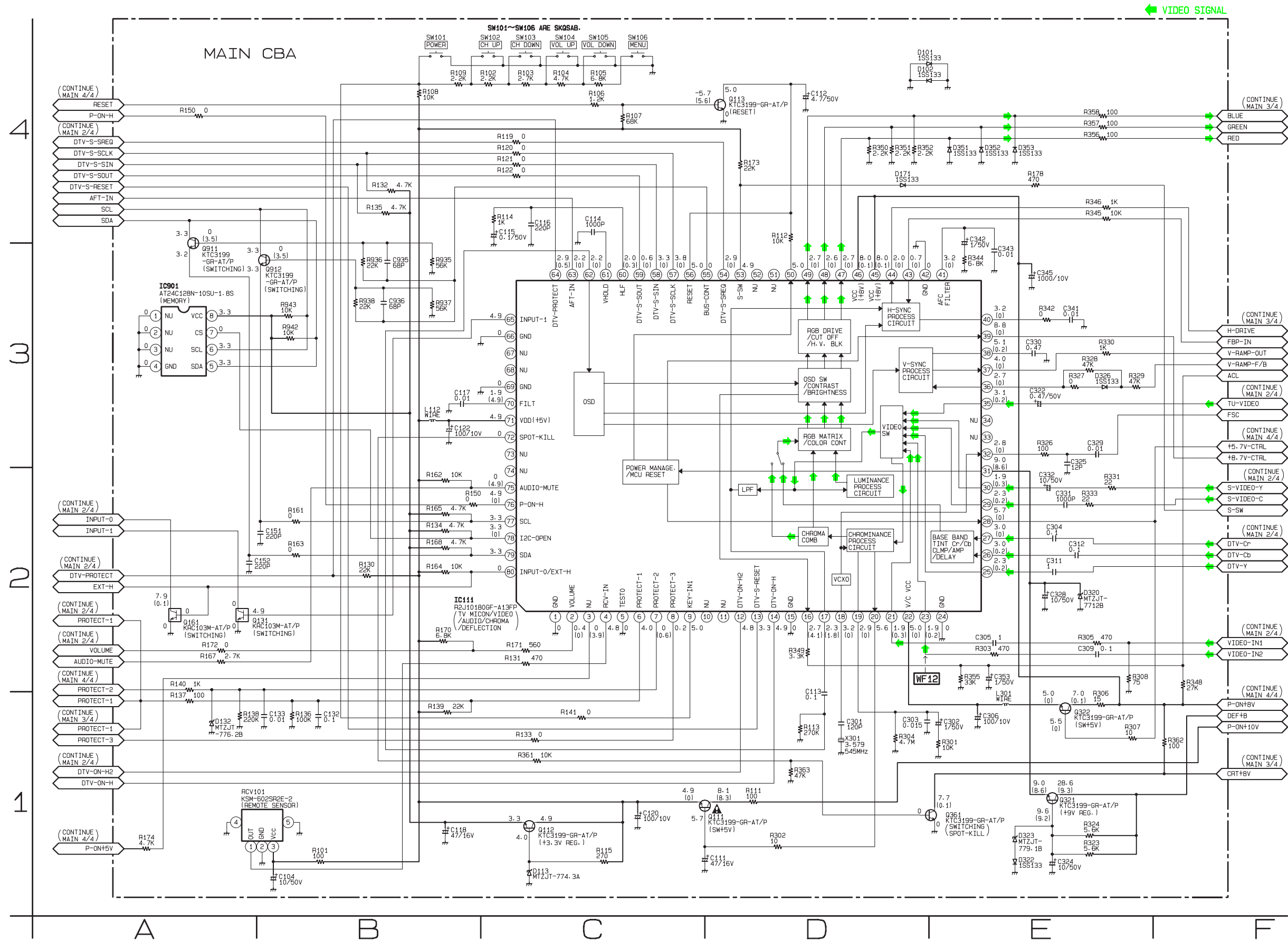

Main 2/4 Schematic Diagram

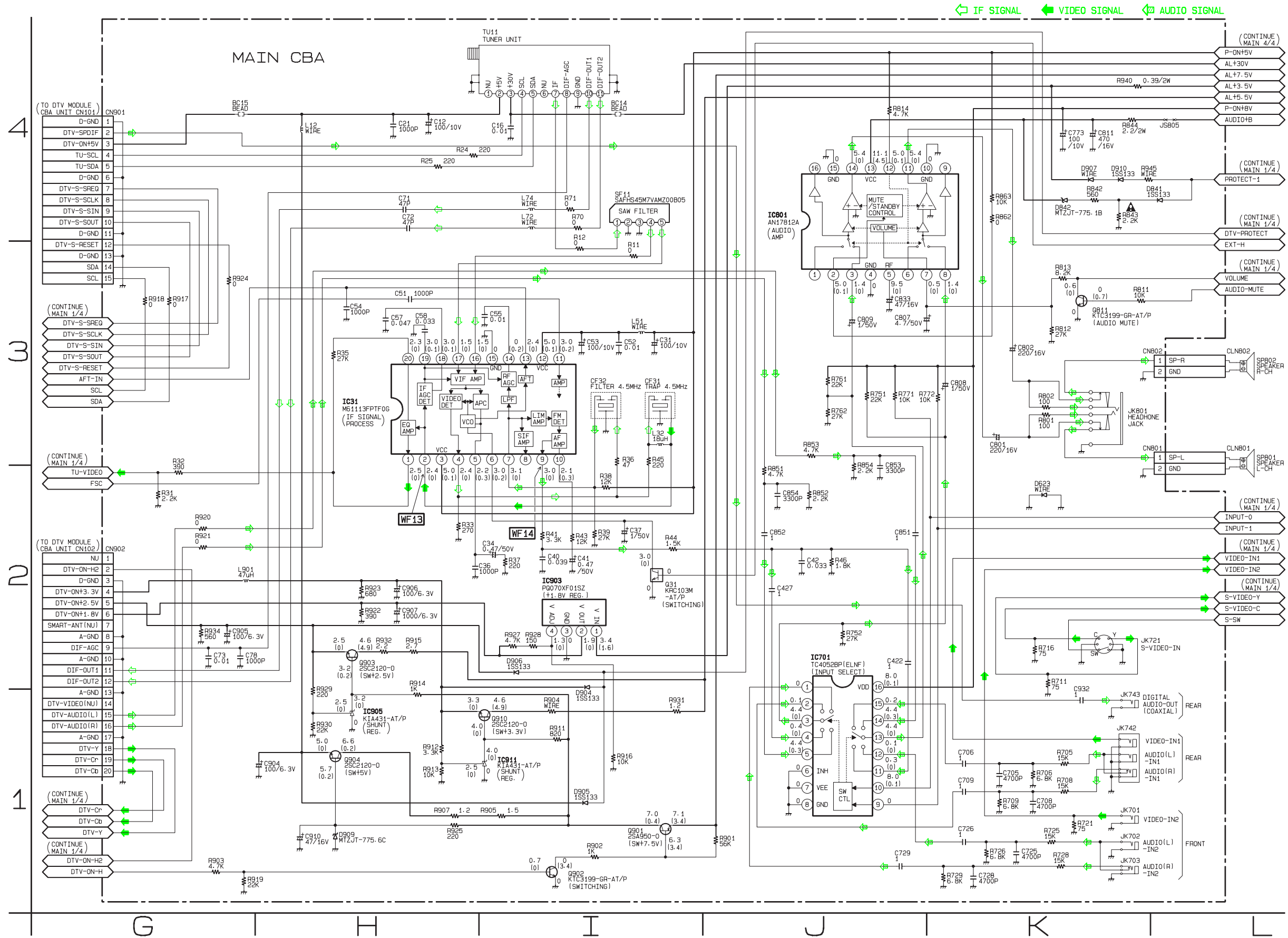

Main 3/4 & CRT Schematic Diagram

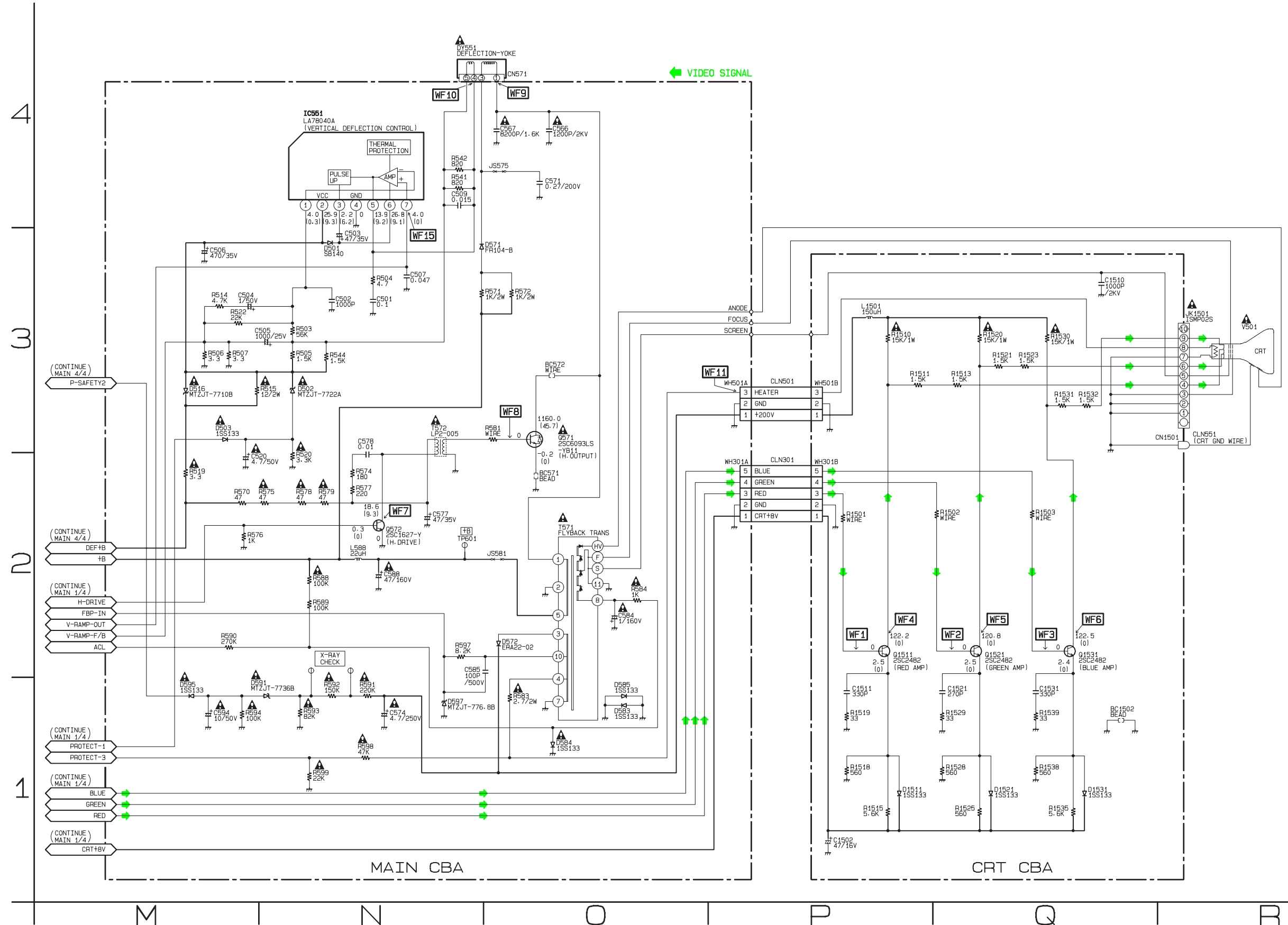

Main 4/4 Schematic Diagram

CAUTION !

Fixed voltage (or Auto voltage selectable) power supply circuit is used in this unit.
If Main Fuse (F601) is blown, check to see that all components in the power supply circuit are not defective before you connect the AC plug to the AC power supply.
Otherwise it may cause some components in the power supply circuit to fail.

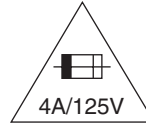

CAUTION ! : For continued protection against risk of fire, replace only with same type 4 A, 125V fuse.
ATTENTION : Utiliser un fusible de rechange de même type de 4A, 125V.

NOTE:

The voltage for parts in hot circuit is measured using hot GND as a common terminal.

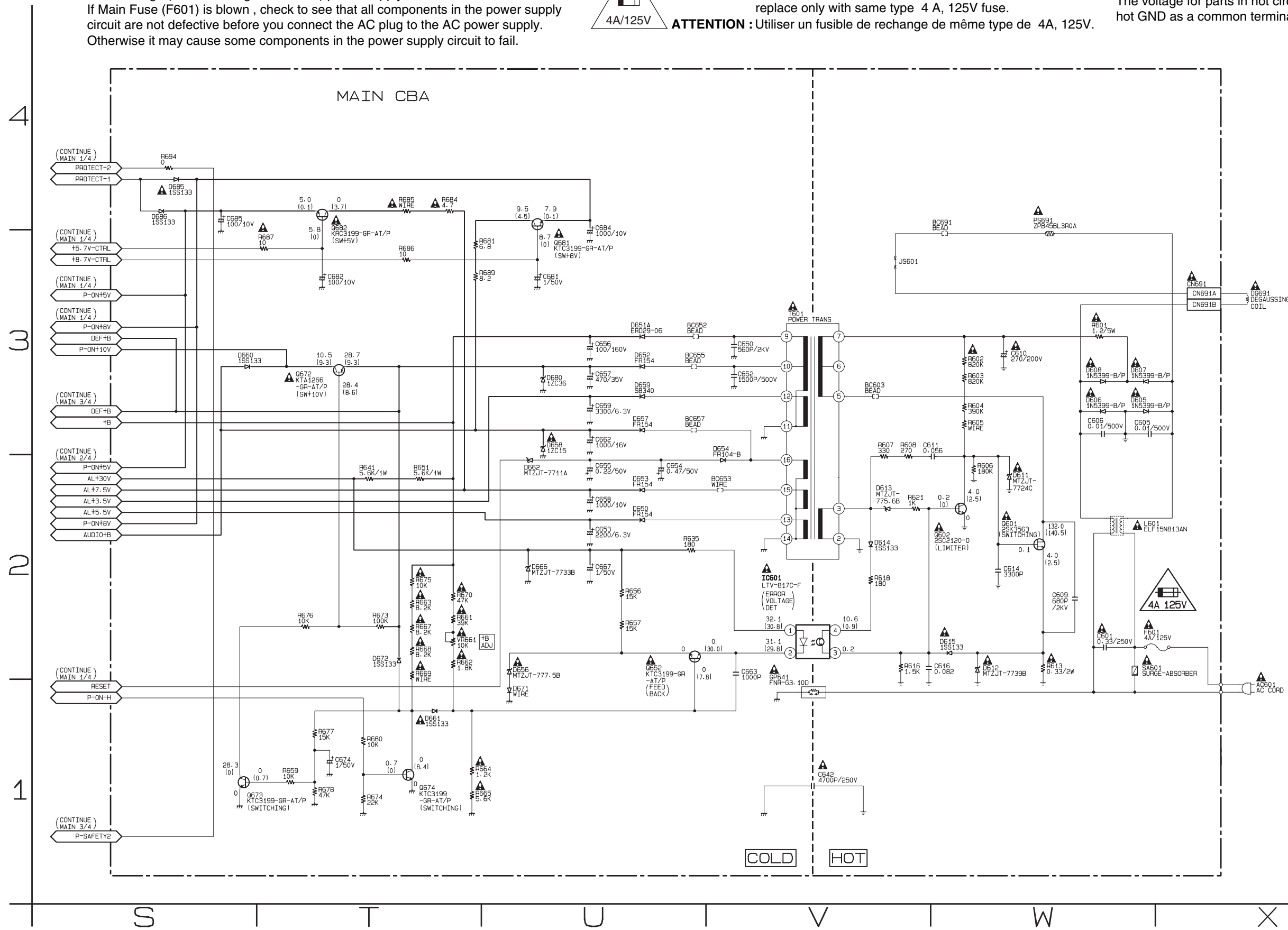

DTV Module 1/2 Schematic Diagram

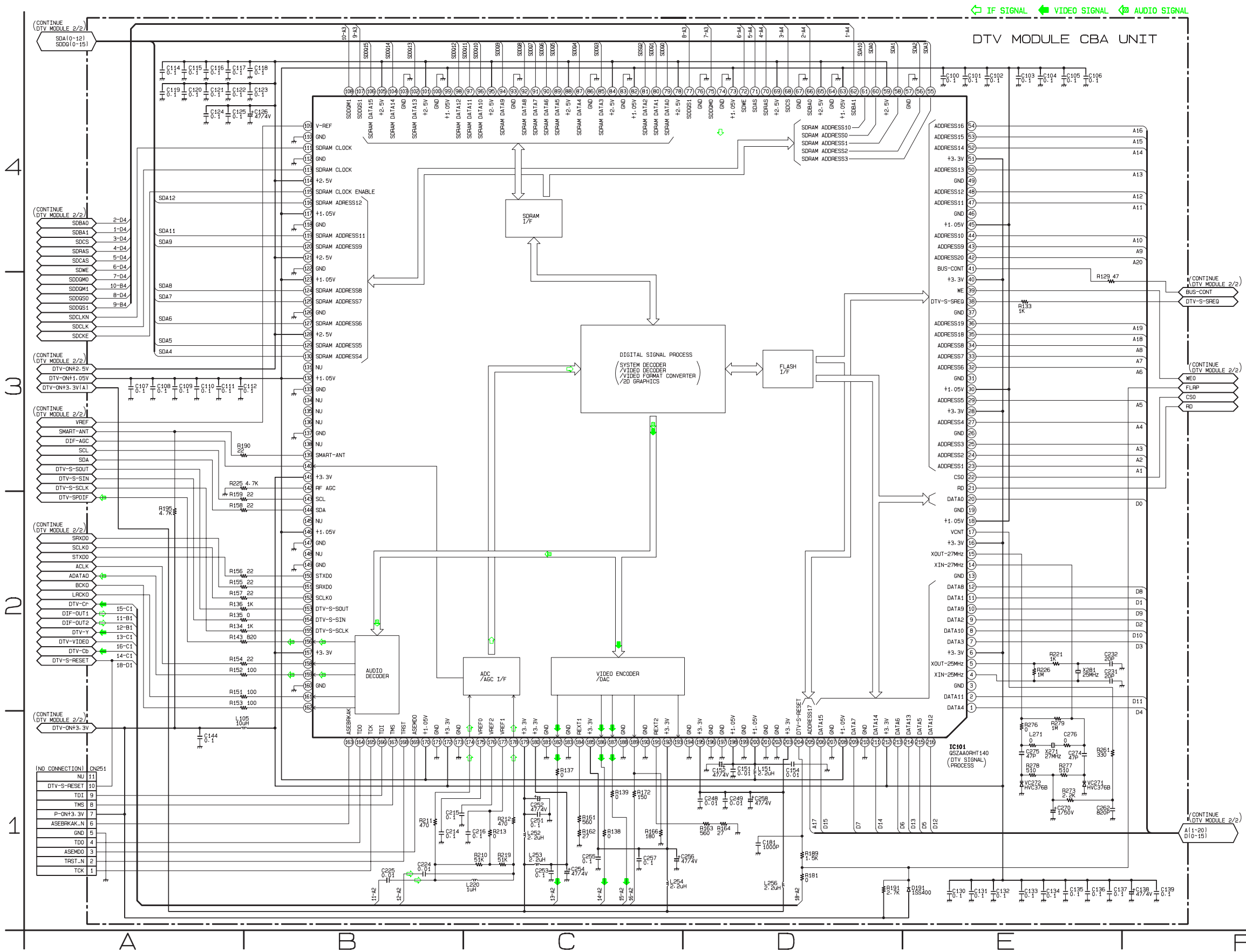

DTV Module 2/2 Schematic Diagram

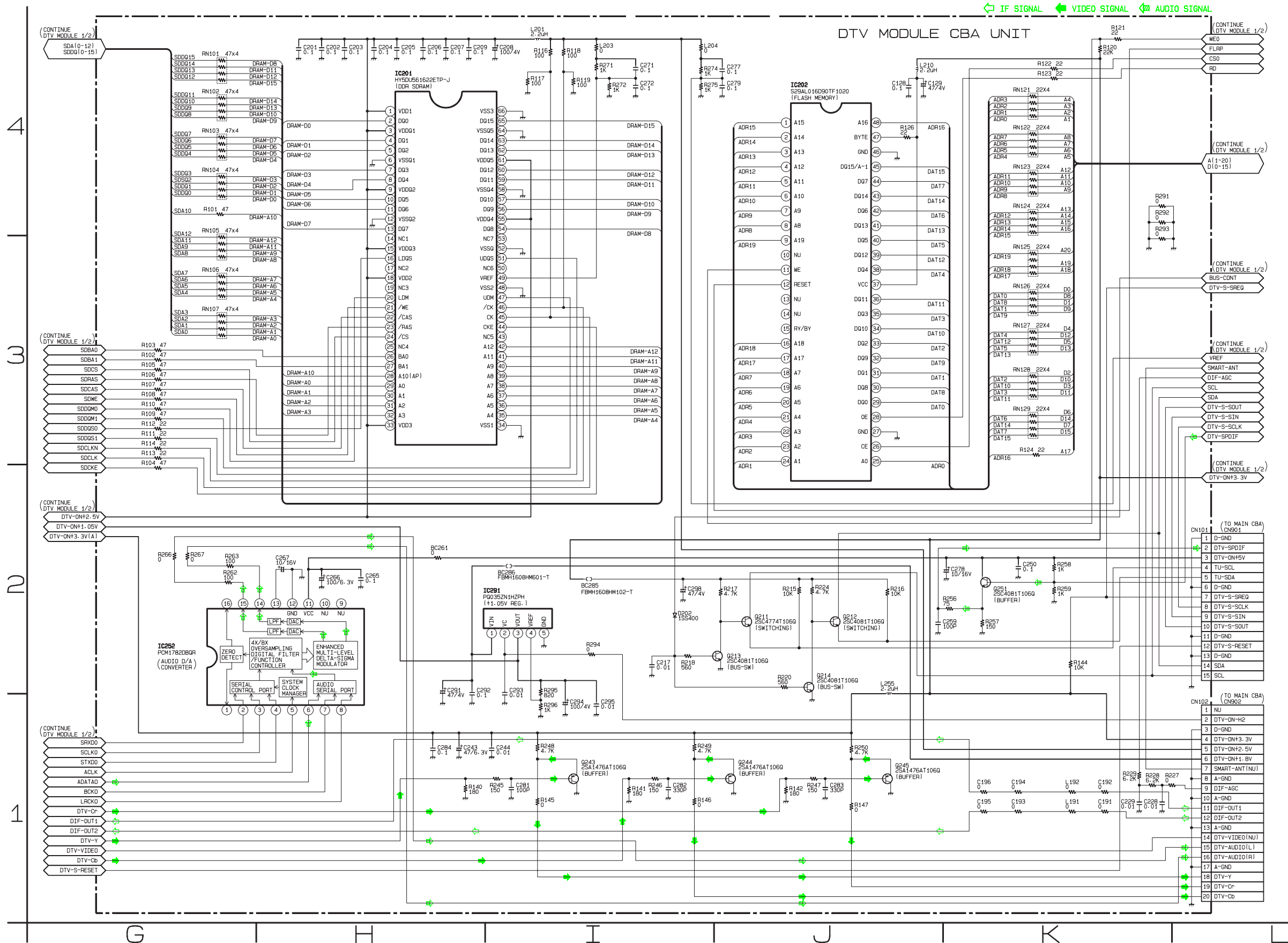

VOLTAGE CHART

CN101

Pin No.	Voltage
1	0
2	1.5
3	5.0
4	3.3
5	3.3
6	0
7	0
8	2.7
9	3.2
10	3.2
11	0
12	3.3
13	0
14	3.3
15	3.3

CN102

Pin No.	Voltage
1	---
2	4.8
3	0
4	3.3
5	2.5
6	1.8
7	---
8	0
9	0.5
10	0
11	0
12	0
13	0
14	---
15	2.4
16	2.4
17	0
18	~
19	~
20	~

Main CBA Bottom View

CAUTION !

Fixed voltage (or Auto voltage selectable) power supply circuit is used in this unit. If Main Fuse (F601) is blown, check to see that all components in the power supply circuit are not defective before you connect the AC plug to the AC power supply. Otherwise it may cause some components in the power supply circuit to fail.

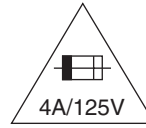

CAUTION ! : For continued protection against risk of fire, replace only with same type 4 A, 125V fuse.
ATTENTION : Utiliser un fusible de rechange de même type de 4A, 125V.

NOTE:

The voltage for parts in hot circuit is measured using hot GND as a common terminal.

Because a hot chassis ground is present in the power supply circuit, an isolation transformer must be used. Also, in order to have the ability to increase the input slowly, when troubleshooting this type power supply circuit, a variable isolation transformer is required.

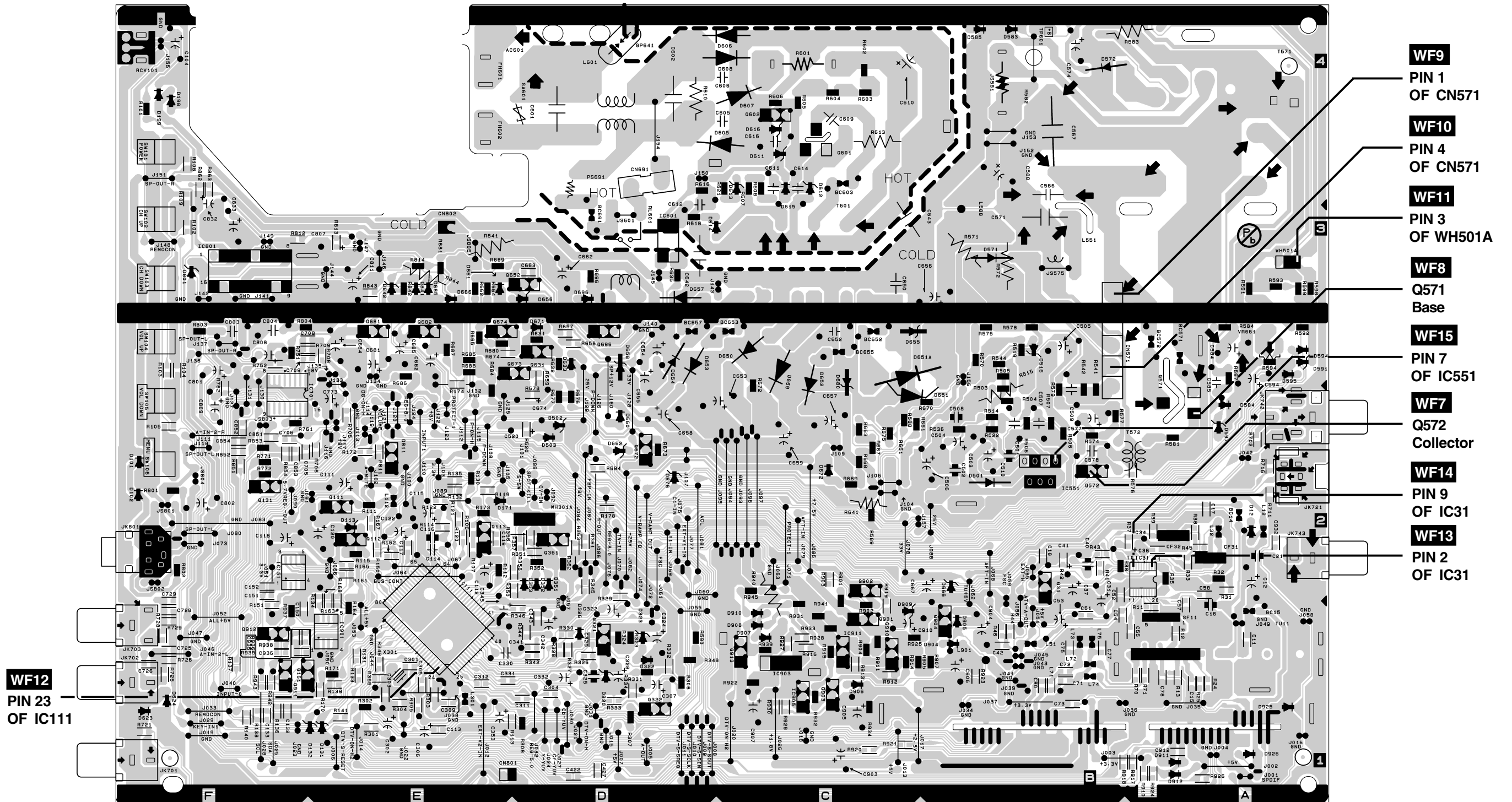

- WF9**
PIN 1
OF CN571
- WF10**
PIN 4
OF CN571
- WF11**
PIN 3
OF WH501A
- WF8**
Q571
Base
- WF15**
PIN 7
OF IC551
- WF7**
Q572
Collector
- WF14**
PIN 9
OF IC31
- WF13**
PIN 2
OF IC31

- WF12**
PIN 23
OF IC111
- WF15**
PIN 7
OF IC551

CRT CBA Top View

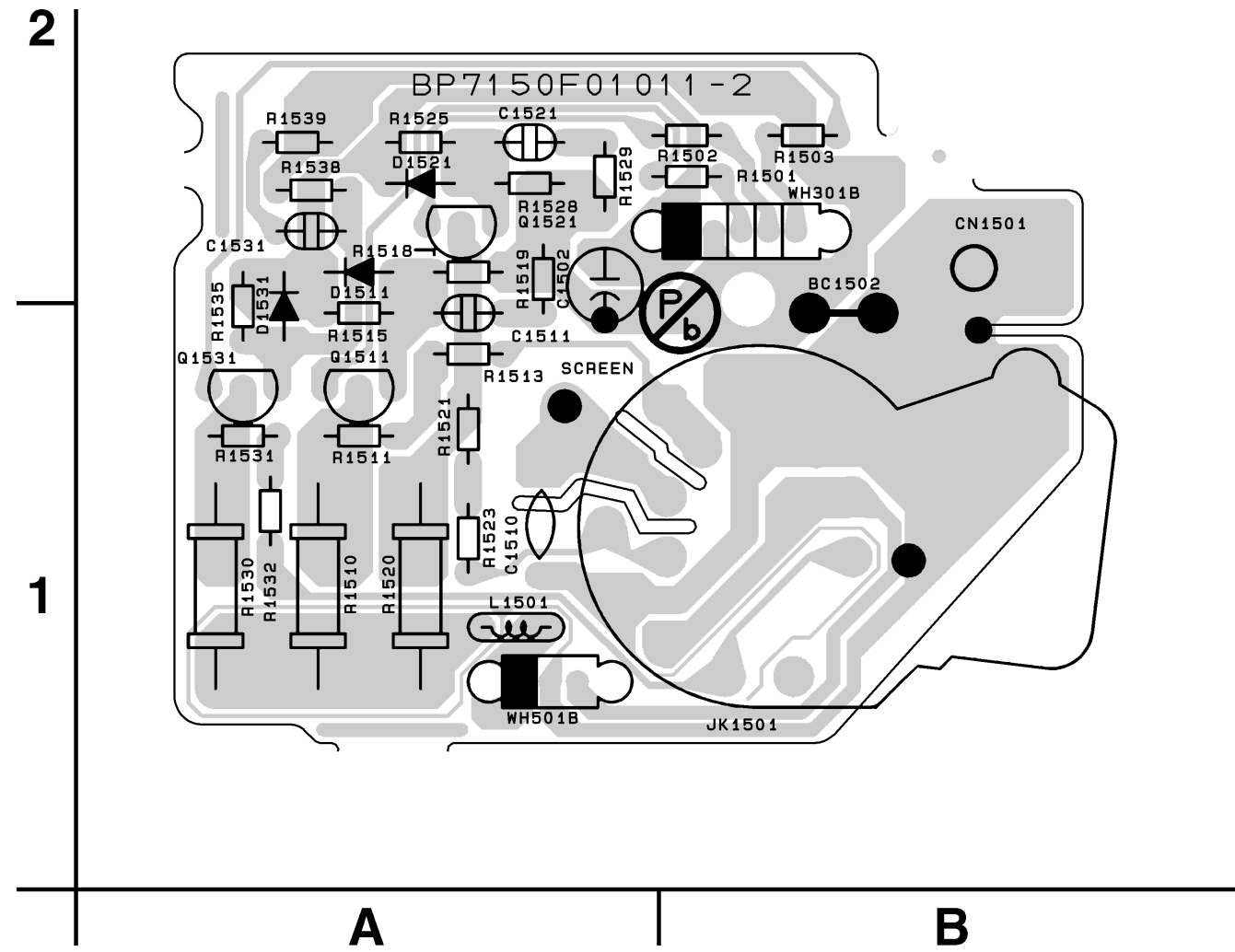

CRT CBA Bottom View

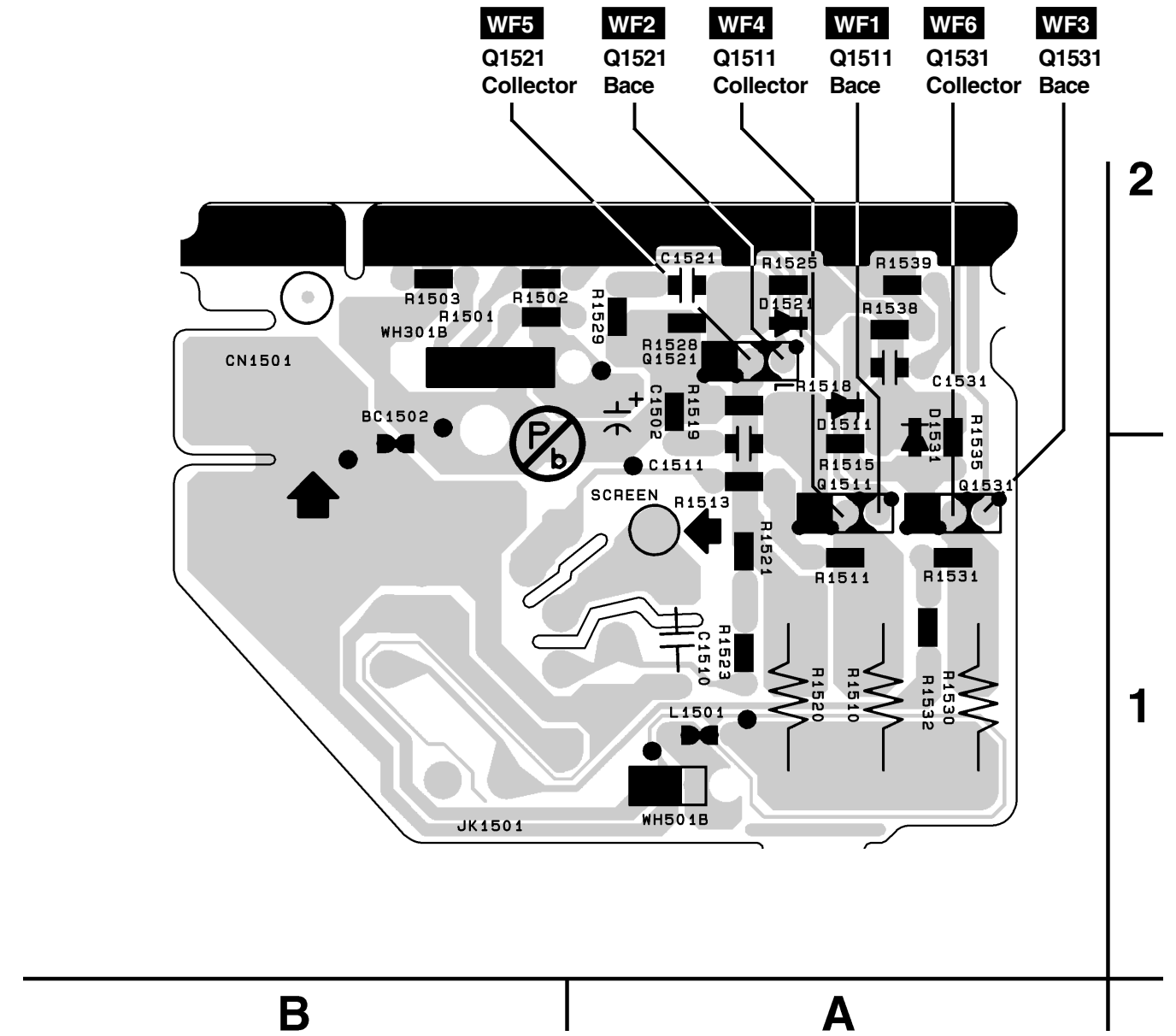

WAVEFORMS

WF1 ~ WF15 = Waveforms to be observed at
Waveform check points.
(Shown in Schematic Diagram.)

Input: NTSC Color Bar Signal (with 1kHz Audio Signal)

INITIAL POSITION: Unplug unit from AC outlet for at least 5 minutes.
reconnect to AC outlet and then turn power on.

(Brightness---Center Color---Center Tint---Center Contrast---Approx 70%)

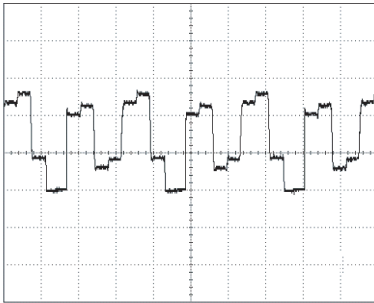

WF1 1DIV: 2V 20 μ s
Q 1511 Base

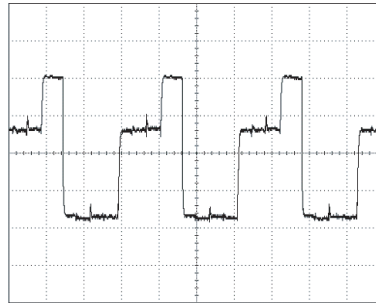

WF5 1DIV: 20V 20 μ s
Q 1521 Collector

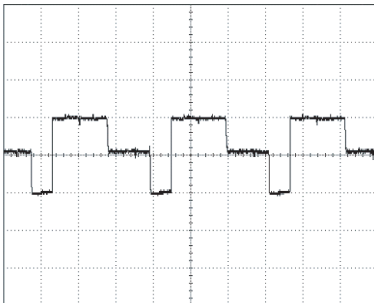

WF2 1DIV: 2V 20 μ s
Q 1521 Base

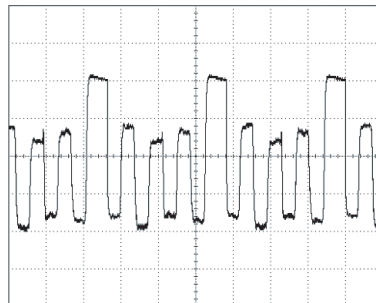

WF6 1DIV: 20V 20 μ s
Q 1531 Collector

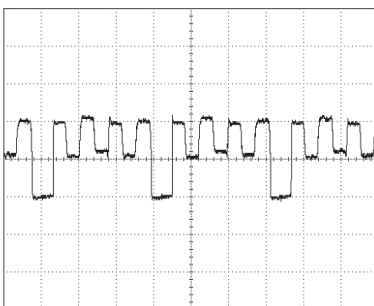

WF3 1DIV: 2V 20 μ s
Q 1531 Base

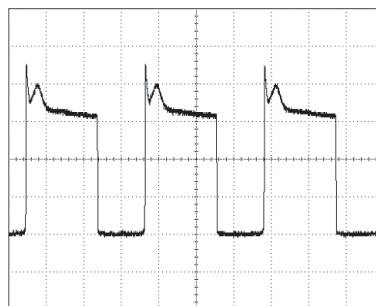

WF7 1DIV: 10V 20 μ s
Q 572 Collector

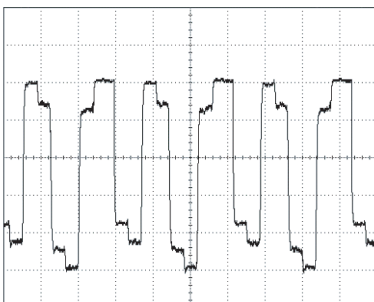

WF4 1DIV: 20V 20 μ s
Q 1511 Collector

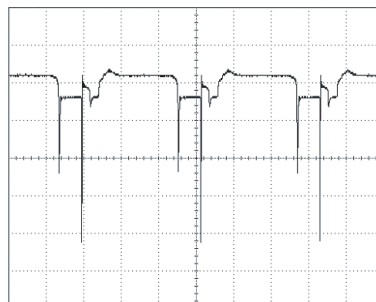

WF8 1DIV: 5V 20 μ s
Q 571 Base

WF1 ~ WF15 = Waveforms to be observed at
Waveform check points.
(Shown in Schematic Diagram.)

Input: NTSC Color Bar Signal (with 1kHz Audio Signal)

INITIAL POSITION: Unplug unit from AC outlet for at least 5 minutes.
reconnect to AC outlet and then turn power on.

(Brightness---Center Color---Center Tint---Center Contrast---Approx 70%)

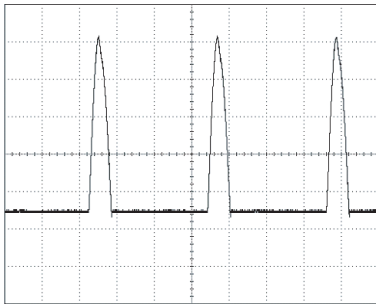

WF9 1DIV: 200V 20 μ s
CN 571 Pin 1

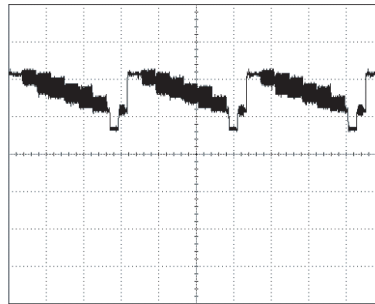

WF13 1DIV: 500mV 20 μ s
IC 31 Pin 2

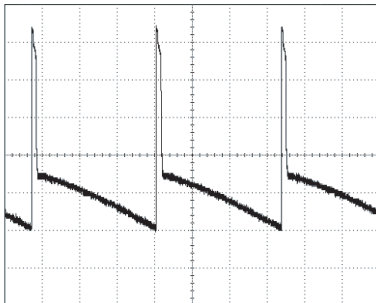

WF10 1DIV: 10V 5ms
CN 571 Pin 4

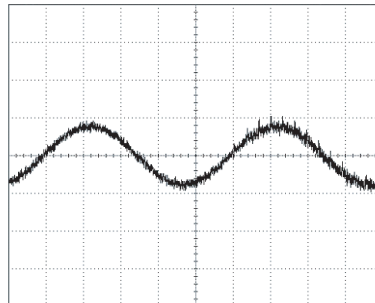

WF14 1DIV: 500mV 200 μ s
IC 31 Pin 9

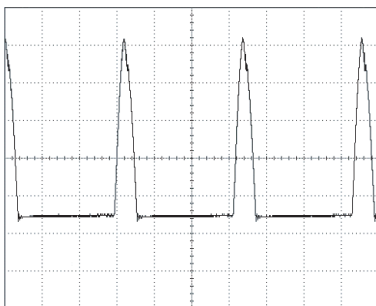

WF11 1DIV: 5V 20 μ s
WH 501A Pin 3

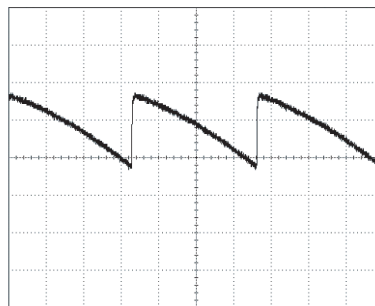

WF15 1DIV: 1V 5ms
IC 551 Pin 7

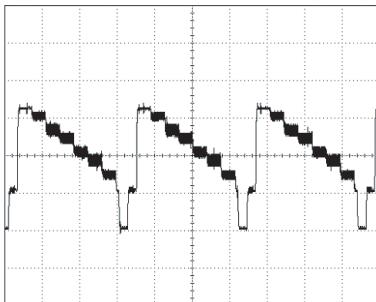

WF12 1DIV: 500mV 20 μ s
IC 111 Pin 23

WIRING DIAGRAM

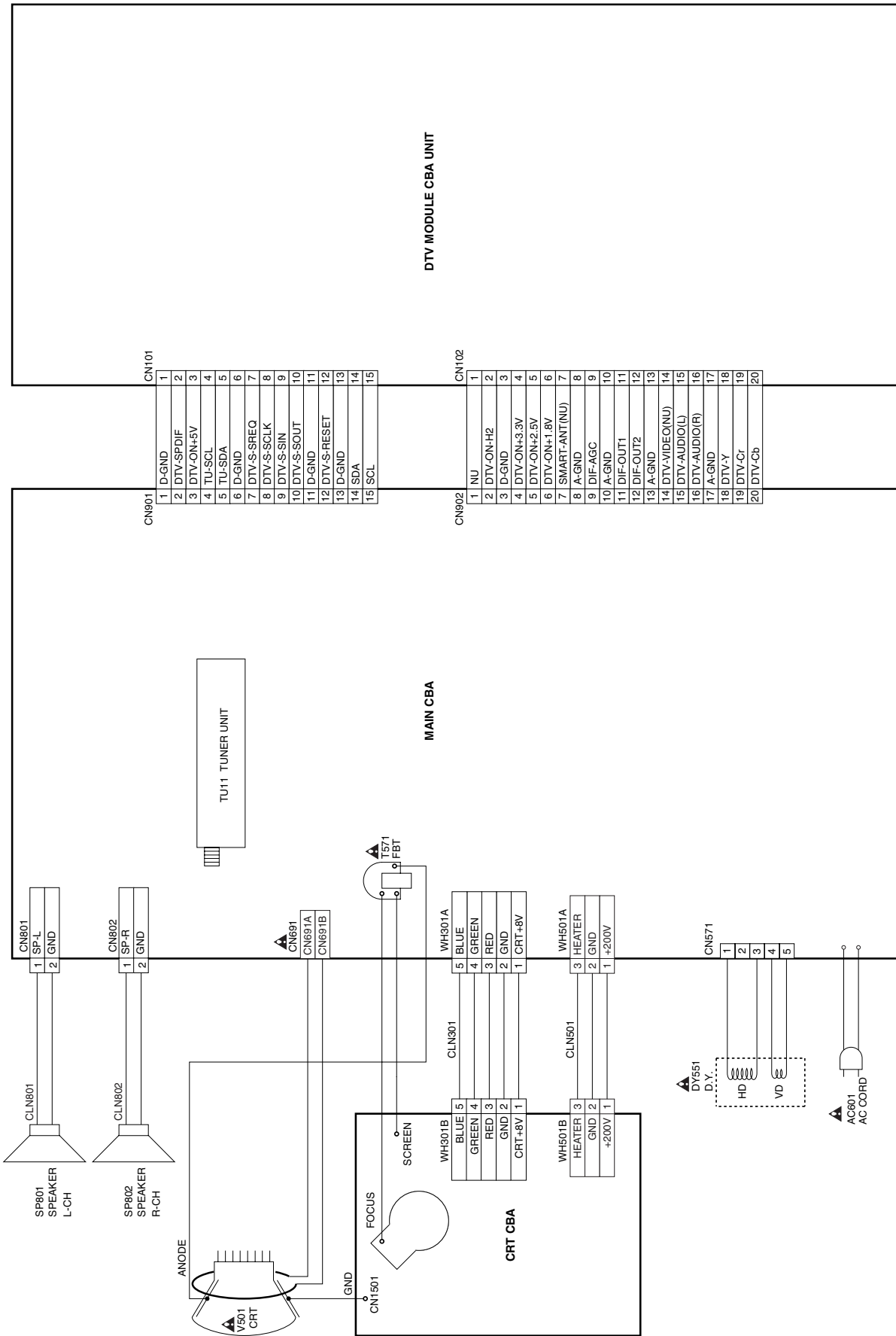

IC PIN FUNCTION DESCRIPTIONS

IC111 (TV Micro Controller)

Pin No.	Signal Name	Function
1	GND	GND
2	VOLUME	Volume Control Signal Output
3	NU	Not Used
4	RCV-IN	Remote Control Signal Input
5	TEST0	GND
6	PROTECT-1	Power Supply Protection 1
7	PROTECT-2	Power Supply Protection 2
8	PROTECT-3	Power Supply Protection 3
9	KEY-IN1	Key Input 1
10	NU	Not Used
11	NU	Not Used
12	DTV-ON-H2	DTV On Signal 2 at High
13	DTV-S-RESET	DTV Reset
14	DTV-ON-H	DTV On Signal at High
15	GND	GND
16	ACL	Automatic Contrast Limiter
17	Y-SW OUT	Composite Video Signal Output
18	XTAL	Crystal Oscillation(3.58MHz)
19	C-APC	Chrominance APC
20	MCU +5.7V REG.OUT	+5.7V Regulator Control Signal Output
21	CVBS-IN3	Composite Video Signal 3 Input
22	V/C VCC	VCC
23	CVBS-IN2	Composite Video Signal 2 Input
24	GND	GND
25	DTV-Y-IN	DTV Y Signal Input
26	DTV-Cb-IN	DTV Cb Signal Input
27	DTV-Cr-IN	DTV Cr Signal Input
28	+5.7V REG.OUT	+5.7V Regulator Control Signal Output
29	C-IN[Y/C]	Chrominance Signal Input
30	Y-IN[Y/C]	Luminance Signal Input
31	VREG VCC	VCC
32	FSC-OUT	Clock Output
33	NU	Not Used
34	NU	Not Used
35	CVBS-IN1	Composite Video Signal 1 Input
36	V-RAMP-F/B	Vertical Ramp Feed Back

Pin No.	Signal Name	Function
37	V-RAMP-OUT	Vertical Ramp Output
38	V-RAMP-CAP	Vertical Ramp OSC Capacitor
39	+8.7V REG.OUT	+8.7V Regulator Control Signal Output
40	H VCO F/B	Horizontal Vco Feed Back
41	AFC FILT	Horizontal AFC Filter
42	GND	GND
43	FBP-IN	Flyback Pulse Input
44	H-OUT	Horizontal Pulse Output
45	VCC(+8V)	+8V VCC
46	VCC(+8V)	+8V VCC
47	R-OUT	Red Signal Output
48	G-OUT	Green Signal Output
49	B-OUT	Blue Signal Output
50	RESET-OUT	Reset Output
51	NU	Not Used
52	NU	Not Used
53	S-SW	Detecting S-VIDEO Jack Connection
54	DTV-S-SREQ	DTV Serial Request
55	BUS-CONT	BUS Control
56	RESET	Reset
57	DTV-S-SCLK	DTV Serial Clock
58	DTV-S-SIN	DTV Serial Data In
59	DTV-S-SOUT	DTV Serial Data Out
60	HLF	Horizontal Filter
61	VHOLD	Vertical Hold
62	CV-IN	Composite Video Signal Input
63	AFT-IN	AFT Voltage Input
64	DTV-PROTECT	DTV Power Supply Protection
65	INPUT-1	Input Select 1 Signal Output
66	GND	GND
67	NU	Not Used
68	NU	Not Used
69	GND	GND
70	FILT	Filter
71	VDD(+5V)	+5V VDD
72	SPOT-KILL	Counter Measure for Spot
73	NU	Not Used
74	NU	Not Used
75	AUDIO-MUTE	Audio Mute Signal Output
76	P-ON-H	Power On Signal at High

Pin No.	Signal Name	Function
77	SCL	Serial Clock
78	I2C-OPEN	Chip Select
79	SDA	Serial Data
80	INPUT-0 / EXT-H	Input Select Signal Output / External Input at High

EXPLODED VIEWS

Cabinet

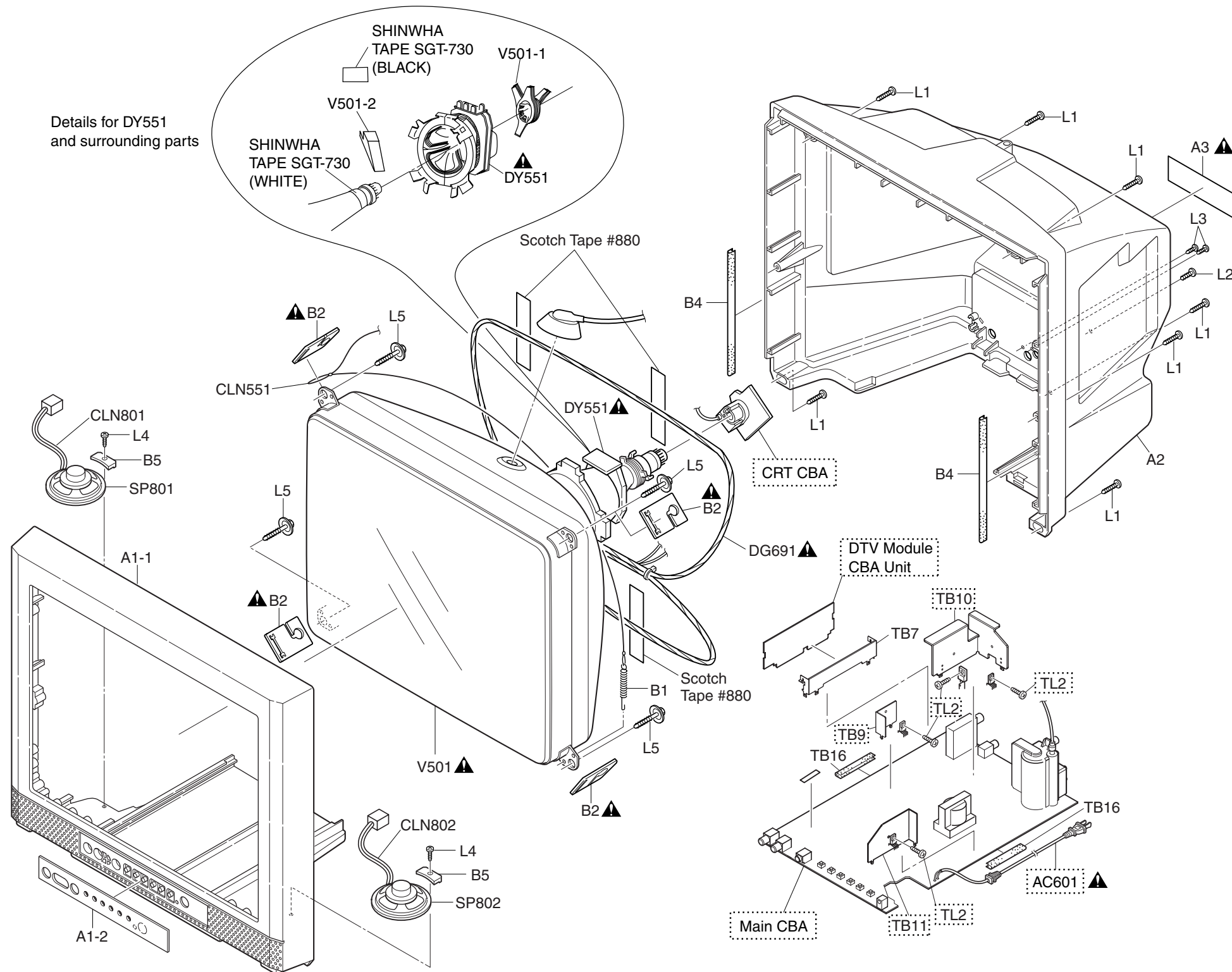



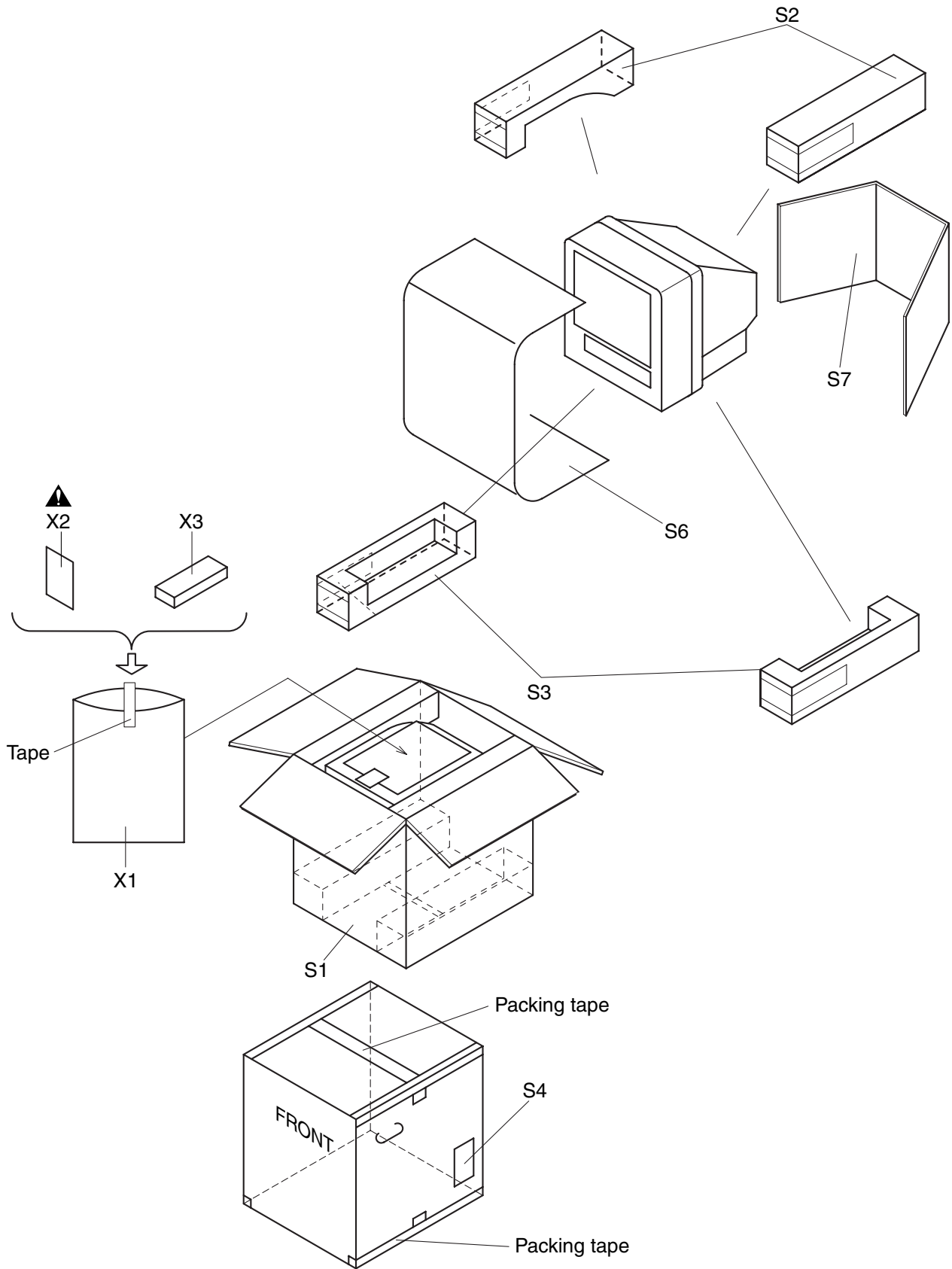

Packing



MECHANICAL PARTS LIST

PRODUCT SAFETY NOTE: Products marked with a  have special characteristics important to safety. Before replacing any of these components, read carefully the product safety notice in this service manual. Don't degrade the safety of the product through improper servicing.

NOTE: Parts that are not assigned part numbers (-----) are not available.

Ref. No.	Description	Part No.
A1-1	FRONT CABINET L3314WQ	1EM121215
A1-2	CONTROL PLATE P7151UM	1EM322514
A2	REAR CABINET P7150UT	1EM021560
A3 	RATING LABEL P7151UM	-----
B1	TENSION SPRING P77B0UT	1EM424298
B2 	DEGAUSS HOLDER L2401UB	1EM420205
B4	CLOTH L9800UA 95X15XT 0 0.5	0EM405041
B5	SPEAKER HOLDER L2404UE	1EM420493
CLN551	CRT GND WIRE	WX1L7820-003
CLN801	WIRE ASSEMBLY	WX1L9200-001
CLN802	WIRE ASSEMBLY SPEAKER WIRE(180MM)	WX1L1131-001
DG691 	DEGAUSSING COIL (AL) ZTM054A	LLBH00ZTM069
DY551 	DEFLECTION YOKE ADY2101F	LLEY0ZAEC002
L1	SCREW P-TIGHT 4X18 BIND HEAD +	GBJP4180
L2	SCREW TAPPING M4X14	DBT14140
L3	SCREW P-TIGHT 3X10 BIND HEAD+	GBHP3100
L4	SCREW P-TIGHT 3X14 BIND HEAD +	GBJP3140
L5	SCREW L1500UA	0EM406142A
SP801	SPEAKER S08N04	DSD0808XQ013
SP802	SPEAKER S08N04	DSD0808XQ013
TB7	MODULE PCB HOLDER P7150UZ	1EM322373
TB16	CLOTH 10X65XT0.3	1EM420328
V501 	CRT A51LYX996X	TCRT190MS015
V501-1	C.PMAGNET JH225-19C	XM04000BV016
V501-2	WEDGE FT-00110W	XV10000T4001
PACKING		
S1	CARTON P7151UM	1EM424200
S2	STYROFOAM TOP ASSEMBLY L2404UE	0EM409269
S3	STYROFOAM BOTTOM ASSEMBLY L2404UE	0EM409270
S4	RFID LABEL P7100UM	-----
S6	SET SHEET B7500UA 1000X1700	0EM402178
S7	HOLD PAD L1400UA	0EM406207
ACCESSORIES		
X1	BAG POLYETHYLENE 235X365XT0.03	0EM408420A
X2 	OWNERS MANUAL ENGLISH	1EMN22122
X3	REMOTE CONTROL NE601UE	NE601UE

ELECTRICAL PARTS LIST

PRODUCT SAFETY NOTE: Products marked with a  have special characteristics important to safety. Before replacing any of these components, read carefully the product safety notice in this service manual. Don't degrade the safety of the product through improper servicing.

NOTES:

- Parts that are not assigned part numbers (-----) are not available.
- Tolerance of Capacitors and Resistors are noted with the following symbols.

C.....±0.25% D.....±0.5% F.....±1%
 G.....±2% J.....±5% K.....±10%
 M.....±20% N.....±30% Z.....+80/-20%

DTV MODULE CBA UNIT

Ref. No.	Description	Part No.
	DTV MODULE CBA UNIT	1ESA13966

MMA CBA

Ref. No.	Description	Part No.
	MMA CBA Consists of the following:	1ESA13844
	MAIN CBA	-----
	CRT CBA	-----

MAIN CBA

Ref. No.	Description	Part No.
	MAIN CBA Consists of the following:	-----
CAPACITORS		
C12	ELECTROLYTIC CAP. 100µF/10V M	CE1AMASDL101
C16	CERAMIC CAP.(AX) B 0.01µF/50V	CKK1JKT0B103
C21	CERAMIC CAP.(AX) B K 1000pF/50V	CCA1JKT0B102
C31	ELECTROLYTIC CAP. 100µF/10V M	CE1AMASDL101
C34	ELECTROLYTIC CAP. 0.47µF/50V M	CE1JMASDLR47
C36	CHIP CERAMIC CAP. B K 1000pF/50V	CHD1JKB0B102
C37	ELECTROLYTIC CAP. 1µF/50V M	CE1JMASDL1R0
C40	CERAMIC CAP BK0.039µF/50V	CA1J393TU011
C41	ELECTROLYTIC CAP. 0.47µF/50V M	CE1JMASDLR47
C42	CHIP CERAMIC CAP. B K 0.033µF/50V	CHD1JKB0B333
C51	CHIP CERAMIC CAP. B K 1000pF/50V	CHD1JKB0B102
C52	CHIP CERAMIC CAP. F Z 0.01µF/50V	CHD1JZB0F103
C53	ELECTROLYTIC CAP. 100µF/10V M	CE1AMASDL101
C54	CHIP CERAMIC CAP. B K 1000pF/50V	CHD1JKB0B102
C55	CHIP CERAMIC CAP. F Z 0.01µF/50V	CHD1JZB0F103
C57	CHIP CERAMIC CAP. B K 0.047µF/50V	CHD1JKB0B473
C58	CHIP CERAMIC CAP. B K 0.033µF/50V	CHD1JKB0B333
C71	CHIP CERAMIC CAP. CH J 47pF/50V	CHD1JJBCH470
C72	CHIP CERAMIC CAP. CH J 47pF/50V	CHD1JJBCH470
C73	CHIP CERAMIC CAP. F Z 0.01µF/50V	CHD1JZB0F103
C78	CHIP CERAMIC CAP. B K 1000pF/50V	CHD1JKB0B102
C104	ELECTROLYTIC CAP. 10µF/50V M	CE1JMASDL100
C111	ELECTROLYTIC CAP. 47µF/16V M	CE1CMASDL470

Ref. No.	Description	Part No.
C112	ELECTROLYTIC CAP. 4.7µF/50V M	CE1JMASDL4R7
C113	CHIP CERAMIC CAP. F Z 0.1µF/50V	CHD1JZB0F104
C114	FILM CAP.(P) 0.001µF/50V J	CMA1JJS00102
C115	ELECTROLYTIC CAP. 0.1µF/50V M	CE1JMASDL0R1
C116	CERAMIC CAP.(AX) B K 220pF/50V	CCA1JKT0B221
C117	CHIP CERAMIC CAP. B K 0.01µF/50V	CHD1JKB0B103
C118	ELECTROLYTIC CAP. 47µF/16V M	CE1CMASDL470
C120	ELECTROLYTIC CAP. 100µF/10V M	CE1AMASDL101
C122	ELECTROLYTIC CAP. 100µF/10V M	CE1AMASDL101
C132	CHIP CERAMIC CAP. F Z 0.1µF/50V	CHD1JZB0F104
C133	CHIP CERAMIC CAP. F Z 0.01µF/50V	CHD1JZB0F103
C151	CHIP CERAMIC CAP. B K 220pF/50V	CHD1JKB0B221
C152	CHIP CERAMIC CAP. B K 220pF/50V	CHD1JKB0B221
C301	CHIP CERAMIC CAP. CH J 120pF/50V	CHD1JJBCH121
C302	ELECTROLYTIC CAP. 1µF/50V M	CE1JMASDL1R0
C303	CHIP CERAMIC CAP. B K 0.015µF/50V	CHD1JKB0B153
C304	CHIP CERAMIC CAP. F Z 0.1µF/50V	CHD1JZB0F104
C305	CHIP CERAMIC CAP. F Z 1µF/10V	CHD1AZB0F105
C306	ELECTROLYTIC CAP. 100µF/10V M	CE1AMASDL101
C309	CHIP CERAMIC CAP. F Z 0.1µF/50V	CHD1JZB0F104
C311	CHIP CERAMIC CAP. F Z 1µF/10V	CHD1AZB0F105
C312	CHIP CERAMIC CAP. F Z 0.1µF/50V	CHD1JZB0F104
C322	ELECTROLYTIC CAP. 0.47µF/50V M	CE1JMASDLR47
C324	ELECTROLYTIC CAP. 10µF/50V M	CE1JMASDL100
C325	CERAMIC CAP.(AX) SL J 12pF/50V	CCA1JJTSL120
C328	ELECTROLYTIC CAP. 10µF/50V M	CE1JMASDL100
C329	CHIP CERAMIC CAP. F Z 0.01µF/50V	CHD1JZB0F103
C330	METALIZED POLYESTER FILM CAP. 0.47µF/50V J	CT1J474DT040
C331	CHIP CERAMIC CAP. B K 1000pF/50V	CHD1JKB0B102
C332	ELECTROLYTIC CAP. 10µF/50V M	CE1JMASDL100
C341	CHIP CERAMIC CAP. B K 0.01µF/50V	CHD1JKB0B103
C342	ELECTROLYTIC CAP. 1µF/50V M	CE1JMASDL1R0
C343	CHIP CERAMIC CAP. B K 0.01µF/50V	CHD1JKB0B103
C345	ELECTROLYTIC CAP. 1000µF/10V M	CE1AMASDL102
C353	ELECTROLYTIC CAP. 1µF/50V M	CE1JMASDL1R0
C422	CHIP CERAMIC CAP. F Z 1µF/16V	CHD1CZB0F105
C427	CHIP CERAMIC CAP. F Z 1µF/16V	CHD1CZB0F105
C501	FILM CAP.(P) 0.1µF/50V J	CMA1JJS00104
C502	CERAMIC CAP.(AX) B K 1000pF/50V	CCA1JKT0B102
C503	ELECTROLYTIC CAP. 47µF/35V M	CE1GMASDL470
C504	ELECTROLYTIC CAP. 1µF/50V LL	CE1JMASLH1R0
C505	ELECTROLYTIC CAP. 1000µF/25V M	CE1EMZPDL102
C506	ELECTROLYTIC CAP. 470µF/35V M	CE1GMZADL471
C507	FILM CAP.(P) 0.047µF/50V J	CMA1JJS00473
C509	FILM CAP.(P) 0.015µF/50V J	CMA1JJS00153
C520▲	ELECTROLYTIC CAP. 4.7µF/50V M	CE1JMASDL4R7
C566▲	CERAMIC CAP. 1200pF/2KV	CA3D122PAN04
C567▲	P.P. CAP 0.0082µF/1.6K J	CA3C822VC011
C571	P.P.CAP 0.27µF/200 J	CA2D274VC012
C574▲	ELECTROLYTIC CAP. 4.7µF/250V M	CE2EMASDL4R7
C577	ELECTROLYTIC CAP. 47µF/35V M	CE1GMASDL470
C578	FILM CAP.(P) 0.01µF/50V J	CMA1JJS00103
C584▲	ELECTROLYTIC CAP. 1µF/160V M	CE2CMASDL1R0
C585	CERAMIC CAP. B K 100pF/500V	CCD2JKS0B101
C588▲	ELECTROLYTIC CAP. 47µF/160V M W/F	CE2CMZNDL470
C594▲	ELECTROLYTIC CAP. 10µF/50V M	CE1JMASDL100
C601▲	METALIZED FILM CAP. 0.33µF/250V	CT2E334MS037
C605	CERAMIC CAP. F Z 0.01µF/500V	CCD2JZP0F103
C606	CERAMIC CAP. F Z 0.01µF/500V	CCD2JZP0F103

Ref. No.	Description	Part No.
C609	CERAMIC CAP. 680pF/2KV	CA3D681PAN04
C610▲	ELECTROLYTIC CAPACITOR 270µF/200V	CA2D271DYG05
C611	FILM CAP.(P) 0.056µF/50V J	CMA1JJS00563
C614	FILM CAP.(P) 0.0033µF/50V J	CMA1JJS00332
C616	FILM CAP.(P) 0.082µF/50V J	CMA1JJS00823
C642▲	CAP CERAMIC 4700pF/250V/M/KX	CA2E472MR101
C650	CERAMIC CAP. 560pF/2KV	CA3D561PAN04
C652	CERAMIC CAP. B K 1500pF/500V	CCD2JKS0B152
C653	ELECTROLYTIC CAP. 2200µF/6.3V M	CE0KMASDL222
C654	ELECTROLYTIC CAP. 0.47µF/50V M	CE1JMASDLR47
C655	ELECTROLYTIC CAP. 0.22µF/50V M	CE1JMASDLR22
C656	ELECTROLYTIC CAP. 100µF/160V M	CE2CMZNDL101
C657	ELECTROLYTIC CAP. 470µF/35V M	CE1GMZADL471
C658	ELECTROLYTIC CAP. 1000µF/10V M	CE1AMASDL102
C659	ELECTROLYTIC CAP 3300µF/6.3V M	CE0KMZNDL332
C662	ELECTROLYTIC CAP. 1000µF/16V M	CE1CMZPDL102
C663	CHIP CERAMIC CAP. B K 1000pF/50V	CHD1JKB0B102
C667	ELECTROLYTIC CAP. 1µF/50V M	CE1JMASDL1R0
C674	ELECTROLYTIC CAP. 1µF/50V M	CE1JMASDL1R0
C681	ELECTROLYTIC CAP. 1µF/50V M	CE1JMASDL1R0
C682	ELECTROLYTIC CAP. 100µF/10V M	CE1AMASDL101
C684	ELECTROLYTIC CAP. 1000µF/10V M	CE1AMASDL102
C685	ELECTROLYTIC CAP. 100µF/10V M	CE1AMASDL101
C705	CHIP CERAMIC CAP. B K 4700pF/50V	CHD1JKB0B472
C706	CHIP CERAMIC CAP. F Z 1µF/16V	CHD1CZB0F105
C708	CHIP CERAMIC CAP. B K 4700pF/50V	CHD1JKB0B472
C709	CHIP CERAMIC CAP. F Z 1µF/16V	CHD1CZB0F105
C725	CHIP CERAMIC CAP. B K 4700pF/50V	CHD1JKB0B472
C726	CHIP CERAMIC CAP. F Z 1µF/16V	CHD1CZB0F105
C728	CHIP CERAMIC CAP. B K 4700pF/50V	CHD1JKB0B472
C729	CHIP CERAMIC CAP. F Z 1µF/16V	CHD1CZB0F105
C773	ELECTROLYTIC CAP. 100µF/10V M	CE1AMASDL101
C801	ELECTROLYTIC CAP. 220µF/16V M	CE1CMASDL221
C802	ELECTROLYTIC CAP. 220µF/16V M	CE1CMASDL221
C807	ELECTROLYTIC CAP. 4.7µF/50V M	CE1JMASDL4R7
C808	ELECTROLYTIC CAP. 1µF/50V M	CE1JMASDL1R0
C809	ELECTROLYTIC CAP. 1µF/50V M	CE1JMASDL1R0
C811	ELECTROLYTIC CAP. 470µF/16V M	CE1CMASDL471
C833	ELECTROLYTIC CAP. 47µF/16V M	CE1CMASDL470
C851	CHIP CERAMIC CAP. F Z 1µF/10V	CHD1AZB0F105
C852	CHIP CERAMIC CAP. F Z 1µF/10V	CHD1AZB0F105
C853	CHIP CERAMIC CAP. B K 3300pF/50V	CHD1JKB0B332
C854	CHIP CERAMIC CAP. B K 3300pF/50V	CHD1JKB0B332
C904	ELECTROLYTIC CAP. 100µF/6.3V M	CE0KMASDL101
C905	ELECTROLYTIC CAP. 100µF/6.3V M	CE0KMASDL101
C906	ELECTROLYTIC CAP. 100µF/6.3V M	CE0KMASDL101
C907	ELECTROLYTIC CAP. 1000µF/6.3V M	CE0KMASDL102
C910	ELECTROLYTIC CAP. 47µF/16V M	CE1CMASDL470
C932	CHIP CERAMIC CAP. F Z 1µF/10V	CHD1AZB0F105
C935	CHIP CERAMIC CAP. CH J 68pF/50V	CHD1JJBCH680
C936	CHIP CERAMIC CAP. CH J 68pF/50V	CHD1JJBCH680
CONNECTORS		
CN571	CONNECTOR PRINT OSU 5P RTB-1.5-5P (LF)	J3RTC05JG002
CN691A	TERMINAL PRINTBORD PIN MS-PIN155155	JTEA001CHY01
CN691B	TERMINAL PRINTBORD PIN MS-PIN155155	JTEA001CHY01
CN801	CONNECTOR PRINT OSU 008283021200000S+	J383C02UG004
CN802	CONNECTOR PRINT OSU 008283021200000S+	J383C02UG004
DIODES		
D101	SWITCHING DIODE 1SS133(T-77)	QDTZ001SS133
D102	SWITCHING DIODE 1SS133(T-77)	QDTZ001SS133
D113	ZENER DIODE MTZJT-774.3A	QDTA0MTZJ4R3

Ref. No.	Description	Part No.
D132	ZENER DIODE MTZJT-776.2B	QDTB0MTZJ6R2
D171	SWITCHING DIODE 1SS133(T-77)	QDTZ001SS133
D320	ZENER DIODE MTZJT-7712B	QDTB00MTZJ12
D322	SWITCHING DIODE 1SS133(T-77)	QDTZ001SS133
D323	ZENER DIODE MTZJT-779.1B	QDTB0MTZJ9R1
D326	SWITCHING DIODE 1SS133(T-77)	QDTZ001SS133
D351	SWITCHING DIODE 1SS133(T-77)	QDTZ001SS133
D352	SWITCHING DIODE 1SS133(T-77)	QDTZ001SS133
D353	SWITCHING DIODE 1SS133(T-77)	QDTZ001SS133
D501	SCHOTTKY BARRIER DIODE SB140	NDWZ000SB140
D502▲	ZENER DIODE MTZJT-7722A	QDTA00MTZJ22
D503▲	SWITCHING DIODE 1SS133(T-77)	QDTZ001SS133
D516	ZENER DIODE MTZJT-7710B	QDTB00MTZJ10
D571	DIODE FR104-B	NDLZ000FR104
D572	FAST RECOVERY DIODE ERA22-04	QDPZOERA2204
D583	SWITCHING DIODE 1SS133(T-77)	QDTZ001SS133
D584▲	SWITCHING DIODE 1SS133(T-77)	QDTZ001SS133
D585	SWITCHING DIODE 1SS133(T-77)	QDTZ001SS133
D591▲	ZENER DIODE MTZJT-7736B	QDTB00MTZJ36
D595▲	SWITCHING DIODE 1SS133(T-77)	QDTZ001SS133
D597	ZENER DIODE MTZJT-776.8B	QDTB0MTZJ6R8
D605▲	DIODE 1N5399-B/P	NDLZ001N5399
D606▲	DIODE 1N5399-B/P	NDLZ001N5399
D607▲	DIODE 1N5399-B/P	NDLZ001N5399
D608▲	DIODE 1N5399-B/P	NDLZ001N5399
D611▲	ZENER DIODE MTZJT-7724C	QDTC00MTZJ24
D612▲	ZENER DIODE MTZJT-7739B	QDTB00MTZJ39
D613	ZENER DIODE MTZJT-775.6B	QDTB0MTZJ5R6
D614	SWITCHING DIODE 1SS133(T-77)	QDTZ001SS133
D615▲	SWITCHING DIODE 1SS133(T-77)	QDTZ001SS133
D623	PCB JUMPER D0.6-P5.0	JW5.0T
D650	DIODE FR154	NDLZ000FR154
D651A	DIODE FAST RECOVERY ERD29-06	QDLZ0ERD2906
D652	DIODE FR154	NDLZ000FR154
D653	DIODE FR154	NDLZ000FR154
D654	DIODE FR104-B	NDLZ000FR104
D656▲	ZENER DIODE MTZJT-777.5B	QDTB0MTZJ7R5
D657	DIODE FR154	NDLZ000FR154
D658▲	DIODE ZENER 1ZC15(Q)	QDLZ001ZC15Q
D659	SCHOTTKY BARRIER DIODE SB340	NDQZ000SB340
D660	SWITCHING DIODE 1SS133(T-77)	QDTZ001SS133
D661▲	SWITCHING DIODE 1SS133(T-77)	QDTZ001SS133
D662	ZENER DIODE MTZJT-7711A	QDTA00MTZJ11
D666	ZENER DIODE MTZJT-7733B	QDTB00MTZJ33
D671	PCB JUMPER D0.6-P5.0	JW5.0T
D672	SWITCHING DIODE 1SS133(T-77)	QDTZ001SS133
D680	DIODE 1ZC36(Q)	QDLZ001ZC36Q
D685▲	SWITCHING DIODE 1SS133(T-77)	QDTZ001SS133
D686	SWITCHING DIODE 1SS133(T-77)	QDTZ001SS133
D841	SWITCHING DIODE 1SS133(T-77)	QDTZ001SS133
D842	ZENER DIODE MTZJT-775.1B	QDTB0MTZJ5R1
D904	SWITCHING DIODE 1SS133(T-77)	QDTZ001SS133
D905	SWITCHING DIODE 1SS133(T-77)	QDTZ001SS133
D906	SWITCHING DIODE 1SS133(T-77)	QDTZ001SS133
D907	SWITCHING DIODE 1SS133(T-77)	QDTZ001SS133
D909	ZENER DIODE MTZJT-775.6C	QDTC0MTZJ5R6
D910	SWITCHING DIODE 1SS133(T-77)	QDTZ001SS133
ICS		
IC31	IC VIF/SIF M61113FP TF0G	QSZBA0SHT035
IC111	IC MICRO COMPUTER R2J10180GF-A13FP 80P	QSZAA0RHT146
IC551	VERTICAL OUTPUT IC LA78040A	QSBBA0SSY003
IC601▲	PHOTOCOUPLER LTV-817C-F	NPEC0LTV817F

Ref. No.	Description	Part No.
IC701	IC SWITCHING TC4052BF(ELNF)	QSZBA0TTS162
IC801	IC AN17812A	QSZBA0SMS017
IC901	IC EEPROM AT24C128N-10SU-1.8 S	NSZBA0TAZ083
IC903	VOLTAGE REGULATOR PQ070XF01SZH	QSZBA0SSH054
IC905	IC SHUNT REGULATOR KIA431-AT/P	NSZBA0TJY036
IC911	IC SHUNT REGULATOR KIA431-AT/P	NSZBA0TJY036
COILS		
L12	PCB JUMPER D0.6-P5.0	JW5.0T
L32	INDUCTOR 18μH-J-26T	LLAXJATTU180
L51	PCB JUMPER D0.6-P5.0	JW5.0T
L72	PCB JUMPER D0.6-P5.0	JW5.0T
L74	PCB JUMPER D0.6-P5.0	JW5.0T
L112	PCB JUMPER D0.6-P5.0	JW5.0T
L301	PCB JUMPER D0.6-P5.0	JW5.0T
L588	CHOKO COIL 22μH-K	LLBD00PKV021
L601▲	LINE FILTER ELF15N813AN	LLBG00ZMS050
L901	COIL DRUM A60607188/47μH	LLED00PKV001
TRANSISTORS		
Q31	NPN TRANSISTOR KRC103M-AT/P	NQSZKRC103MP
Q111▲	TRANSISTOR KTC3199-GR-AT/P	NQS4KTC3199P
Q112	TRANSISTOR KTC3199-GR-AT/P	NQS4KTC3199P
Q113	TRANSISTOR KTC3199-GR-AT/P	NQS4KTC3199P
Q131	NPN TRANSISTOR KRC103M-AT/P	NQSZKRC103MP
Q161	NPN TRANSISTOR KRC103M-AT/P	NQSZKRC103MP
Q321	TRANSISTOR KTC3199-GR-AT/P	NQS4KTC3199P
Q322	TRANSISTOR KTC3199-GR-AT/P	NQS4KTC3199P
Q361	TRANSISTOR KTC3199-GR-AT/P	NQS4KTC3199P
Q571▲	NPN TRANSISTOR 2SC6093LS-YB11	QQEZ02SC6093
Q572	NPN TRANSISTOR 2SC1627-Y (TE2.F.T)	QQSY2SC1627F
Q601▲	MOS FET 2SK3563	QFWZ02SK3563
Q602▲	TRANSISTOR 2SC2120-O(TE2 F T)	QQS02SC2120F
Q652▲	TRANSISTOR KTC3199-GR-AT/P	NQS4KTC3199P
Q672▲	TRANSISTOR KTA-1266-GR-AT/P	NQS4KTA1266P
Q673	TRANSISTOR KTC3199-GR-AT/P	NQS4KTC3199P
Q674	TRANSISTOR KTC3199-GR-AT/P	NQS4KTC3199P
Q681▲	TRANSISTOR KTC3199-GR-AT/P	NQS4KTC3199P
Q682▲	TRANSISTOR KTC3199-GR-AT/P	NQS4KTC3199P
Q811	TRANSISTOR KTC3199-GR-AT/P	NQS4KTC3199P
Q901	TRANSISTOR 2SA950-O (TE2 F T)	QQS002SA950F
Q902	TRANSISTOR KTC3199-GR-AT/P	NQS4KTC3199P
Q903	TRANSISTOR 2SC2120-O(TE2 F T)	QQS02SC2120F
Q904	TRANSISTOR 2SC2120-O(TE2 F T)	QQS02SC2120F
Q910	TRANSISTOR 2SC2120-O(TE2 F T)	QQS02SC2120F
Q911	TRANSISTOR KTC3199-GR-AT/P	NQS4KTC3199P
Q912	TRANSISTOR KTC3199-GR-AT/P	NQS4KTC3199P
RESISTORS		
R11	CHIP RES.(1608) 1/10W 0 Ω	RRXAZB5Z0000
R12	CHIP RES.(1608) 1/10W 0 Ω	RRXAZB5Z0000
R24	CHIP RES. 1/10W J 220 Ω	RRXAJB5Z0221
R25	CHIP RES. 1/10W J 220 Ω	RRXAJB5Z0221
R31	CHIP RES. 1/10W J 2.2k Ω	RRXAJB5Z0222
R32	CARBON RES. 1/4W J 390 Ω	RCX4JATZ0391
R33	CHIP RES. 1/10W J 270 Ω	RRXAJB5Z0271
R35	CARBON RES. 1/4W J 27k Ω	RCX4JATZ0273
R36	CHIP RES. 1/10W J 47 Ω	RRXAJB5Z0470
R37	CHIP RES. 1/10W J 220 Ω	RRXAJB5Z0221
R38	CARBON RES. 1/4W J 12k Ω	RCX4JATZ0123
R39	CHIP RES. 1/10W J 27k Ω	RRXAJB5Z0273
R41	CHIP RES. 1/10W J 3.3k Ω	RRXAJB5Z0332
R43	CHIP RES. 1/10W J 12k Ω	RRXAJB5Z0123
R44	CHIP RES. 1/10W J 1.5k Ω	RRXAJB5Z0152
R45	CHIP RES. 1/10W J 220 Ω	RRXAJB5Z0221

Ref. No.	Description	Part No.
R46	CHIP RES. 1/10W J 1.8k Ω	RRXAJB5Z0182
R70	CHIP RES.(1608) 1/10W 0 Ω	RRXAZB5Z0000
R71	CHIP RES.(1608) 1/10W 0 Ω	RRXAZB5Z0000
R101	CARBON RES. 1/4W J 100 Ω	RCX4JATZ0101
R102	CHIP RES. 1/10W J 2.2k Ω	RRXAJB5Z0222
R103	CHIP RES. 1/10W J 2.7k Ω	RRXAJB5Z0272
R104	CHIP RES. 1/10W J 4.7k Ω	RRXAJB5Z0472
R105	CHIP RES. 1/10W J 6.8k Ω	RRXAJB5Z0682
R106	CHIP RES. 1/10W J 1.2k Ω	RRXAJB5Z0122
R107	CHIP RES. 1/10W J 68k Ω	RRXAJB5Z0683
R108	CHIP RES. 1/10W J 10k Ω	RRXAJB5Z0103
R109	CHIP RES. 1/10W J 2.2k Ω	RRXAJB5Z0222
R111	CARBON RES. 1/4W J 100 Ω	RCX4JATZ0101
R112	CARBON RES. 1/4W J 10k Ω	RCX4JATZ0103
R113	CHIP RES. 1/10W J 270k Ω	RRXAJB5Z0274
R114	CHIP RES. 1/10W J 1k Ω	RRXAJB5Z0102
R115	CARBON RES. 1/4W J 270 Ω	RCX4JATZ0271
R119	CHIP RES.(1608) 1/10W 0 Ω	RRXAZB5Z0000
R120	CHIP RES.(1608) 1/10W 0 Ω	RRXAZB5Z0000
R121	CHIP RES.(1608) 1/10W 0 Ω	RRXAZB5Z0000
R122	CHIP RES.(1608) 1/10W 0 Ω	RRXAZB5Z0000
R130	CARBON RES. 1/4W J 22k Ω	RCX4JATZ0223
R131	CHIP RES. 1/10W J 470 Ω	RRXAJB5Z0471
R132	CHIP RES. 1/10W J 4.7k Ω	RRXAJB5Z0472
R133	CHIP RES.(1608) 1/10W 0 Ω	RRXAZB5Z0000
R134	CHIP RES. 1/10W J 4.7k Ω	RRXAJB5Z0472
R135	CHIP RES. 1/10W J 4.7k Ω	RRXAJB5Z0472
R136	CHIP RES. 1/10W J 100k Ω	RRXAJB5Z0104
R137	CHIP RES. 1/10W J 100 Ω	RRXAJB5Z0101
R138	CHIP RES. 1/10W J 220k Ω	RRXAJB5Z0224
R139	CHIP RES. 1/10W J 22k Ω	RRXAJB5Z0223
R140	CHIP RES. 1/10W J 1k Ω	RRXAJB5Z0102
R141	CHIP RES.(1608) 1/10W 0 Ω	RRXAZB5Z0000
R150	CHIP RES.(1608) 1/10W 0 Ω	RRXAZB5Z0000
R161	CHIP RES.(1608) 1/10W 0 Ω	RRXAZB5Z0000
R162	CHIP RES. 1/10W J 10k Ω	RRXAJB5Z0103
R163	CHIP RES.(1608) 1/10W 0 Ω	RRXAZB5Z0000
R164	CARBON RES. 1/4W J 10k Ω	RCX4JATZ0103
R165	CHIP RES. 1/10W J 4.7k Ω	RRXAJB5Z0472
R167	CHIP RES. 1/10W J 2.7k Ω	RRXAJB5Z0272
R168	CHIP RES. 1/10W J 4.7k Ω	RRXAJB5Z0472
R170	CHIP RES. 1/10W J 6.8k Ω	RRXAJB5Z0682
R171	CARBON RES. 1/4W J 560 Ω	RCX4JATZ0561
R172	CHIP RES.(1608) 1/10W 0 Ω	RRXAZB5Z0000
R173	CARBON RES. 1/4W J 22k Ω	RCX4JATZ0223
R174	CHIP RES. 1/10W J 4.7k Ω	RRXAJB5Z0472
R178	CHIP RES. 1/10W J 470 Ω	RRXAJB5Z0471
R301	CHIP RES. 1/10W J 10k Ω	RRXAJB5Z0103
R302	CARBON RES. 1/4W J 10 Ω	RCX4JATZ0100
R303	CHIP RES. 1/10W J 470 Ω	RRXAJB5Z0471
R304	CHIP RES. 1/10W J 4.7M Ω	RRXAJB5Z0475
R305	CHIP RES. 1/10W J 470 Ω	RRXAJB5Z0471
R306	CARBON RES. 1/4W J 15 Ω	RCX4JATZ0150
R307	CARBON RES. 1/4W J 10 Ω	RCX4JATZ0100
R308	CARBON RES. 1/4W J 75 Ω	RCX4JATZ0750
R323	CARBON RES. 1/4W J 5.6k Ω	RCX4JATZ0562
R324	CARBON RES. 1/4W J 5.6k Ω	RCX4JATZ0562
R326	CHIP RES. 1/10W J 100 Ω	RRXAJB5Z0101
R327	CHIP RES.(1608) 1/10W 0 Ω	RRXAZB5Z0000
R328	CHIP RES. 1/10W J 47k Ω	RRXAJB5Z0473
R329	CHIP RES. 1/10W J 47k Ω	RRXAJB5Z0473
R330	CHIP RES. 1/10W J 1k Ω	RRXAJB5Z0102
R331	CARBON RES. 1/4W J 22 Ω	RCX4JATZ0220

Ref. No.	Description	Part No.
R333	CHIP RES. 1/10W J 22 Ω	RRXAJB5Z0220
R342	CHIP RES.(1608) 1/10W 0 Ω	RRXAZB5Z0000
R344	CHIP RES. 1/10W J 6.8k Ω	RRXAJB5Z0682
R345	CHIP RES. 1/10W J 10k Ω	RRXAJB5Z0103
R346	CHIP RES. 1/10W J 1k Ω	RRXAJB5Z0102
R348	CARBON RES. 1/4W J 27k Ω	RCX4JATZ0273
R349	CHIP RES. 1/10W J 3.3k Ω	RRXAJB5Z0332
R350	CHIP RES. 1/10W J 2.2k Ω	RRXAJB5Z0222
R351	CHIP RES. 1/10W J 2.2k Ω	RRXAJB5Z0222
R352	CARBON RES. 1/4W J 2.2k Ω	RCX4JATZ0222
R355	CHIP RES. 1/10W J 33k Ω	RRXAJB5Z0333
R356	CHIP RES. 1/10W J 100 Ω	RRXAJB5Z0101
R357	CHIP RES. 1/10W J 100 Ω	RRXAJB5Z0101
R358	CHIP RES. 1/10W J 100 Ω	RRXAJB5Z0101
R361	CHIP RES. 1/10W J 10k Ω	RRXAJB5Z0103
R362	CARBON RES. 1/4W J 100 Ω	RCX4JATZ0101
R363	CHIP RES. 1/10W J 47k Ω	RRXAJB5Z0473
R503	CARBON RES. 1/4W J 56k Ω	RCX4JATZ0563
R504	CARBON RES. 1/4W J 4.7 Ω	RCX4JATZ047
R505	CARBON RES. 1/4W J 1.5k Ω	RCX4JATZ0152
R506	CARBON RES. 1/4W J 3.3 Ω	RCX4JATZ03R3
R507	CARBON RES. 1/4W J 3.3 Ω	RCX4JATZ03R3
R514	CARBON RES. 1/4W J 4.7k Ω	RCX4JATZ0472
R515▲	METAL OXIDE FILM RES. 2W J 12 Ω	RN02120ZU001
R519▲	CARBON RES. 1/4W J 3.3 Ω	RCX4JATZ03R3
R520▲	CHIP RES. 1/10W J 3.3k Ω	RRXAJB5Z0332
R522	CARBON RES. 1/4W J 22k Ω	RCX4JATZ0223
R541	CARBON RES. 1/4W J 820 Ω	RCX4JATZ0821
R542	CARBON RES. 1/4W J 820 Ω	RCX4JATZ0821
R544	CARBON RES. 1/4W J 1.5k Ω	RCX4JATZ0152
R570	CARBON RES. 1/4W J 47 Ω	RCX4JATZ0470
R571	METAL OXIDE FILM RES. 2W J 1k Ω	RN02102ZU001
R572	METAL OXIDE FILM RES. 2W J 1k Ω	RN02102ZU001
R574	CARBON RES. 1/4W J 180 Ω	RCX4JATZ0181
R575▲	CARBON RES. 1/4W J 47 Ω	RCX4JATZ0470
R576	CHIP RES. 1/10W J 1k Ω	RRXAJB5Z0102
R577	CARBON RES. 1/4W J 220 Ω	RCX4JATZ0221
R578▲	CARBON RES. 1/4W J 47 Ω	RCX4JATZ0470
R579▲	CARBON RES. 1/4W J 47 Ω	RCX4JATZ0470
R581	PCB JUMPER D0.6-P5.0	JW5.0T
R583▲	METAL OXIDE FILM RES. 2W J 2.7 Ω	RN02JZLZ02R7
R584▲	CARBON RES. 1/4W J 1k Ω	RCX4JATZ0102
R588▲	CARBON RES. 1/4W J 100k Ω	RCX4JATZ0104
R589	CARBON RES. 1/4W J 100k Ω	RCX4JATZ0104
R590	CARBON RES. 1/4W J 270k Ω	RCX4JATZ0274
R591▲	CARBON RES. 1/4W G 220k Ω	RCX4GATZ0224
R592▲	CARBON RES. 1/4W G 150k Ω	RCX4GATZ0154
R593▲	CARBON RES. 1/4W G 82k Ω	RCX4GATZ0823
R594▲	CARBON RES. 1/4W J 100k Ω	RCX4JATZ0104
R597	CARBON RES. 1/4W J 8.2k Ω	RCX4JATZ0822
R598▲	CARBON RES. 1/4W J 47k Ω	RCX4JATZ0473
R599▲	CARBON RES. 1/4W J 22k Ω	RCX4JATZ0223
R601▲	CEMENT RES 5W K 1.2 Ω	RW051R2PG002
R602▲	CARBON RES. 1/4W J 820k Ω	RCX4JATZ0824
R603	CARBON RES. 1/4W J 820k Ω	RCX4JATZ0824
R604	CARBON RES. 1/4W J 390k Ω	RCX4JATZ0394
R605	PCB JUMPER D0.6-P5.0	JW5.0T
R606	CARBON RES. 1/4W J 180k Ω	RCX4JATZ0184
R607	CARBON RES. 1/4W J 330 Ω	RCX4JATZ0331
R608	CARBON RES. 1/4W J 270 Ω	RCX4JATZ0271
R613▲	METAL OXIDE FILM RES. 2W J 0.33 Ω	RN02R33ZU001
R616	CARBON RES. 1/4W J 1.5k Ω	RCX4JATZ0152
R618	CARBON RES. 1/4W J 180 Ω	RCX4JATZ0181

Ref. No.	Description	Part No.
R621	CARBON RES. 1/4W J 1k Ω	RCX4JATZ0102
R635	CARBON RES. 1/4W J 180 Ω	RCX4JATZ0181
R641	METAL OXIDE FILM RES. 1W J 5.6k Ω	RN01562ZU001
R651	METAL OXIDE FILM RES. 1W J 5.6k Ω	RN01562ZU001
R656	CHIP RES. 1/10W J 15k Ω	RRXAJB5Z0153
R657	CHIP RES. 1/10W J 15k Ω	RRXAJB5Z0153
R659	CHIP RES. 1/10W J 10k Ω	RRXAJB5Z0103
R661▲	CARBON RES. 1/4W J 39k Ω	RCX4JATZ0393
R662▲	CARBON RES. 1/4W J 1.8k Ω	RCX4JATZ0182
R663▲	CARBON RES. 1/4W J 8.2k Ω	RCX4JATZ0822
R664▲	CARBON RES. 1/4W J 1.2k Ω	RCX4JATZ0122
R665▲	CARBON RES. 1/4W J 5.6k Ω	RCX4JATZ0562
R667▲	CARBON RES. 1/4W J 8.2k Ω	RCX4JATZ0822
R668▲	CARBON RES. 1/4W J 8.2k Ω	RCX4JATZ0822
R669▲	PCB JUMPER D0.6-P5.0	JW5.0T
R670▲	CARBON RES. 1/4W J 47k Ω	RCX4JATZ0473
R673	CARBON RES. 1/4W J 100k Ω	RCX4JATZ0104
R674	CHIP RES. 1/10W J 22k Ω	RRXAJB5Z0223
R675▲	CARBON RES. 1/4W J 10k Ω	RCX4JATZ0103
R676	CARBON RES. 1/4W J 10k Ω	RCX4JATZ0103
R677	CARBON RES. 1/4W J 15k Ω	RCX4JATZ0153
R678	CHIP RES. 1/10W J 47k Ω	RRXAJB5Z0473
R680	CARBON RES. 1/4W J 10k Ω	RCX4JATZ0103
R681	CARBON RES. 1/4W J 6.8 Ω	RCX4JATZ06R8
R684▲	CARBON RES. 1/4W J 4.7 Ω	RCX4JATZ047
R685▲	PCB JUMPER D0.6-P5.0	JW5.0T
R686	CARBON RES. 1/4W J 10 Ω	RCX4JATZ0100
R687▲	CARBON RES. 1/4W J 10 Ω	RCX4JATZ0100
R689	CARBON RES. 1/4W J 8.2 Ω	RCX4JATZ08R2
R694	CHIP RES.(1608) 1/10W 0 Ω	RRXAZB5Z0000
R705	CHIP RES. 1/10W J 15k Ω	RRXAJB5Z0153
R706	CHIP RES. 1/10W J 6.8k Ω	RRXAJB5Z0682
R708	CHIP RES. 1/10W J 15k Ω	RRXAJB5Z0153
R709	CHIP RES. 1/10W J 6.8k Ω	RRXAJB5Z0682
R711	CHIP RES. 1/10W J 75 Ω	RRXAJB5Z0750
R716	CHIP RES. 1/10W J 75 Ω	RRXAJB5Z0750
R721	CHIP RES. 1/10W J 75 Ω	RRXAJB5Z0750
R725	CHIP RES. 1/10W J 15k Ω	RRXAJB5Z0153
R726	CHIP RES. 1/10W J 6.8k Ω	RRXAJB5Z0682
R728	CHIP RES. 1/10W J 15k Ω	RRXAJB5Z0153
R729	CHIP RES. 1/10W J 6.8k Ω	RRXAJB5Z0682
R751	CARBON RES. 1/4W J 22k Ω	RCX4JATZ0223
R752	CHIP RES. 1/10W J 27k Ω	RRXAJB5Z0273
R761	CARBON RES. 1/4W J 22k Ω	RCX4JATZ0223
R762	CHIP RES. 1/10W J 27k Ω	RRXAJB5Z0273
R771	CARBON RES. 1/4W J 10k Ω	RCX4JATZ0103
R772	CARBON RES. 1/4W J 10k Ω	RCX4JATZ0103
R801	CARBON RES. 1/4W J 100 Ω	RCX4JATZ0101
R802	CARBON RES. 1/4W J 100 Ω	RCX4JATZ0101
R811	CHIP RES. 1/10W J 10k Ω	RRXAJB5Z0103
R812	CHIP RES. 1/10W J 27k Ω	RRXAJB5Z0273
R813	CHIP RES. 1/10W J 8.2k Ω	RRXAJB5Z0822
R814	CARBON RES. 1/4W J 4.7k Ω	RCX4JATZ0472
R842	PCB JUMPER D0.6-P5.0	JW5.0T
R843▲	CHIP RES. 1/10W J 2.2k Ω	RRXAJB5Z0222
R844	METAL OXIDE FILM RES. 2W J 2.2 Ω	RN022R2ZU001
R851	CHIP RES. 1/10W J 4.7k Ω	RRXAJB5Z0472
R852	CHIP RES. 1/10W J 2.2k Ω	RRXAJB5Z0222
R853	CARBON RES. 1/4W J 4.7k Ω	RCX4JATZ0472
R854	CHIP RES. 1/10W J 2.2k Ω	RRXAJB5Z0222
R862	CHIP RES.(1608) 1/10W 0 Ω	RRXAZB5Z0000
R863	CHIP RES. 1/10W J 10k Ω	RRXAJB5Z0103
R901	CARBON RES. 1/4W J 56k Ω	RCX4JATZ0563

Ref. No.	Description	Part No.
R902	CARBON RES. 1/4W J 1k Ω	RCX4JATZ0102
R903	CHIP RES. 1/10W J 4.7k Ω	RRXAJB5Z0472
R904	PCB JUMPER D0.6-P5.0	JW5.0T
R905	CARBON RES. 1/4W J 1.5 Ω	RCX4JATZ01R5
R907	CARBON RES. 1/4W J 1.2 Ω	RCX4JATZ01R2
R911	CARBON RES. 1/4W J 820 Ω	RCX4JATZ0821
R912	CHIP RES. 1/10W J 3.3k Ω	RRXAJB5Z0332
R913	CHIP RES. 1/10W J 10k Ω	RRXAJB5Z0103
R914	CARBON RES. 1/4W J 1k Ω	RCX4JATZ0102
R915	CARBON RES. 1/4W J 2.7 Ω	RCX4JATZ02R7
R916	CHIP RES. 1/10W F 10k Ω	RRXAFB5H1002
R917	CHIP RES.(1608) 1/10W 0 Ω	RRXAZB5Z0000
R918	CHIP RES.(1608) 1/10W 0 Ω	RRXAZB5Z0000
R919	CHIP RES. 1/10W J 22k Ω	RRXAJB5Z0223
R920	CHIP RES.(1608) 1/10W 0 Ω	RRXAZB5Z0000
R921	CHIP RES.(1608) 1/10W 0 Ω	RRXAZB5Z0000
R922	CARBON RES. 1/4W J 390 Ω	RCX4JATZ0391
R923	CHIP RES. 1/10W J 680 Ω	RRXAJB5Z0681
R924	CHIP RES.(1608) 1/10W 0 Ω	RRXAZB5Z0000
R925	CARBON RES. 1/4W J 220 Ω	RCX4JATZ0221
R927	CHIP RES. 1/10W F 4.7k Ω	RRXAFB5H4701
R928	CHIP RES. 1/10W F 150 Ω	RRXAFB5H1500
R929	CHIP RES. 1/10W F 220 Ω	RRXAFB5H2200
R930	CHIP RES. 1/10W F 22k Ω	RRXAFB5H2202
R931	CARBON RES. 1/4W J 1.2 Ω	RCX4JATZ01R2
R932	CARBON RES. 1/4W J 2.2 Ω	RCX4JATZ02R2
R934	CARBON RES. 1/4W J 560 Ω	RCX4JATZ0561
R935	CHIP RES. 1/10W J 56k Ω	RRXAJB5Z0563
R936	CHIP RES. 1/10W J 22k Ω	RRXAJB5Z0223
R937	CARBON RES. 1/4W J 56k Ω	RCX4JATZ0563
R938	CHIP RES. 1/10W J 22k Ω	RRXAJB5Z0223
R940	METAL OXIDE FILM RES. 2W J 0.39 Ω	RN02R39ZU001
R942	CHIP RES. 1/10W J 10k Ω	RRXAJB5Z0103
R943	CHIP RES. 1/10W J 10k Ω	RRXAJB5Z0103
R945	PCB JUMPER D0.6-P5.0	JW5.0T
SWITCHES		
SW101	TACT SWITCH SKQSAB	SST0101AL038
SW102	TACT SWITCH SKQSAB	SST0101AL038
SW103	TACT SWITCH SKQSAB	SST0101AL038
SW104	TACT SWITCH SKQSAB	SST0101AL038
SW105	TACT SWITCH SKQSAB	SST0101AL038
SW106	TACT SWITCH SKQSAB	SST0101AL038
MISCELLANEOUS		
AC601▲	AC CORD (PB FREE) A0A0280-012	WAC0172LTE12
BC14	BEAD INDUCTOR FBR07HA121TB-00	LLBF00ZTU021
BC15	BEAD INDUCTOR FBR07HA121TB-00	LLBF00ZTU021
BC571	BEAD INDUCTOR FBA04HA600VB-00	LLBF00STU026
BC572	PCB JUMPER D0.6-P5.0	JW5.0T
BC603	BEAD INDUCTOR FBR07HA121TB-00	LLBF00ZTU021
BC652	BEAD INDUCTOR FBR07HA121TB-00	LLBF00ZTU021
BC653	PCB JUMPER D0.6-P5.0	JW5.0T
BC655	BEAD INDUCTOR FBR07HA121TB-00	LLBF00ZTU021
BC657	BEAD INDUCTOR FBR07HA121TB-00	LLBF00ZTU021
BC691	BEAD INDUCTOR FBR07HA121TB-00	LLBF00ZTU021
CF31	CERAMIC TRAP 4.5MHz	FBE455PMR003
CF32	CERAMIC FILTER SFSRA4M50CF00-B0	FBB455PMR004
CLN301	WIRE ASSEMBLY L=410 5P	WX1L1040-101
CLN501	PARALLEL WIRE 3P	WX1L1114-101
F601▲	FUSE 4.00A/125V	PAGG20CNG402
FH601	FUSE HOLDER MSF-015 LF (B110)	XH01Z00LY002
FH602	FUSE HOLDER MSF-015 LF (B110)	XH01Z00LY002
GP641▲	GAP. FNR-G3.10D	FAZ000LD6005

Ref. No.	Description	Part No.
JK701	RCA JACK(YELLOW) MTJ-032-05B-20(B110)	JXRL010LY135
JK702	RCA JACK(WHITE) MTJ-032-05B-22(B110)	JXRL010LY136
JK703	RCA JACK(RED) MTJ-032-05A-21(B110)	JYRL010LY029
JK721	JACK SW DIN PCB L DIN-435C	JYEL040YUQ02
JK742	JACK SW RCA PCB L RCA-350-00A-01	JYRL030YUQ11
JK743	JACK RCA PCB ORENGE MTJ-032-05B-52 FE LF	JXRL010LY159
JK801	MINIATURE JACK(PB FREE) CKX-035-318AZ4	JYSL010SNJ01
JS575	PCB JUMPER D0.6-P10.0	JW10.0T
JS581	PCB JUMPER D0.6-P5.0	JW5.0T
JS601	PCB JUMPER D0.6-P7.5	JW7.5T
JS805	PCB JUMPER D0.6-P7.5	JW7.5T
PS691▲	THERMISTOR ZPB45BL3R0A	QNBZ45BL3R0A
RCV101	REMOCON RECEIVE UNIT KSM-602SR2E-2	USESJRSKK045
SA601▲	SURGE ABSORBER 470V+-10PER	NVQZ10D471KB
SF11	FILTER CERAMIC BAND PASS SAFHS45M7VAMZ00B05	FBB456LMR005
T571▲	TRANS FBT JF0501-3201-G	LTF00CPXB049
T572▲	HORIZONTAL DRIVE TRANS LP2-005	LTH00CPA5005
T601▲	TRANS POWER 6752	LTT2PCOKT016
TB9	MODULE HEAT SINK PMC P7150UT	1EM423968
TB10	H/V HEAT SINK PMB ASSEMBLY P7150UT	1EM423967
TB11	POW HEAT SINK PMA P7150UT	1EM423965
TL2	SCREW B-TIGHT D3X8 BIND HEAD+	GBJB3080
TP601	PCB JUMPER D0.6-P14.0	JW14.0T
TU11	TUNER UNIT ENV56M07D8F	UTUNATSMS001
VR661▲	CARBON P.O.T. VZ067TL1 B103 PB(F)	VRCB103HH014
X301	XTAL 3.579545 MHz	FXD355LLN003

CRT CBA

Ref. No.	Description	Part No.
	CRT CBA Consists of the following:	-----
CAPACITORS		
C1502	ELECTROLYTIC CAP. 47μF/16V M	CE1CMASDL470
C1510	CERAMIC CAP. B K 1000pF/2KV	CCD3DKD0B102
C1511	CERAMIC CAP.(AX) B K 330pF/50V	CCA1JKT0B331
C1521	CERAMIC CAP.(AX) B K 270pF/50V	CCA1JKT0B271
C1531	CERAMIC CAP.(AX) B K 330pF/50V	CCA1JKT0B331
CONNECTOR		
CN1501	CONNECTOR PIN 1P RT-01N-2.3A	1730688
DIODES		
D1511	SWITCHING DIODE 1SS133(T-77)	QDTZ001SS133
D1521	SWITCHING DIODE 1SS133(T-77)	QDTZ001SS133
D1531	SWITCHING DIODE 1SS133(T-77)	QDTZ001SS133
COIL		
L1501	INDUCTOR 150μH-J-5FT	LLARJCSJU151
TRANSISTORS		
Q1511	NPN TRANSISTOR 2SC2482(T6FUNAIF M	QRSZ2SC2482F
Q1521	NPN TRANSISTOR 2SC2482(T6FUNAIF M	QRSZ2SC2482F
Q1531	NPN TRANSISTOR 2SC2482(T6FUNAIF M	QRSZ2SC2482F
RESISTORS		
R1501	PCB JUMPER D0.6-P5.0	JW5.0T
R1502	PCB JUMPER D0.6-P5.0	JW5.0T
R1503	PCB JUMPER D0.6-P5.0	JW5.0T
R1510▲	METAL OXIDE FILM RES. 1W J 15k Ω	RN01153ZU001
R1511	CARBON RES. 1/4W J 1.5k Ω	RCX4JATZ0152
R1513	CARBON RES. 1/4W J 1.5k Ω	RCX4JATZ0152
R1515	CARBON RES. 1/4W J 5.6k Ω	RCX4JATZ0562
R1518	CARBON RES. 1/4W J 560 Ω	RCX4JATZ0561
R1519	CARBON RES. 1/4W J 33 Ω	RCX4JATZ0330
R1520▲	METAL OXIDE FILM RES. 1W J 15k Ω	RN01153ZU001

Ref. No.	Description	Part No.
R1521	CARBON RES. 1/4W J 1.5k Ω	RCX4JATZ0152
R1523	CARBON RES. 1/4W J 1.5k Ω	RCX4JATZ0152
R1525	CARBON RES. 1/4W J 5.6k Ω	RCX4JATZ0562
R1528	CARBON RES. 1/4W J 560 Ω	RCX4JATZ0561
R1529	CARBON RES. 1/4W J 33 Ω	RCX4JATZ0330
R1530▲	METAL OXIDE FILM RES. 1W J 15k Ω	RN01153ZU001
R1531	CARBON RES. 1/4W J 1.5k Ω	RCX4JATZ0152
R1532	CARBON RES. 1/4W J 1.5k Ω	RCX4JATZ0152
R1535	CARBON RES. 1/4W J 5.6k Ω	RCX4JATZ0562
R1538	CARBON RES. 1/4W J 560 Ω	RCX4JATZ0561
R1539	CARBON RES. 1/4W J 33 Ω	RCX4JATZ0330
MISCELLANEOUS		
BC1502	BEAD INDUCTOR FBR07HA121TB-00	LLBF00ZTU021
JK1501▲	CRT SOCKET ISMP02S	JSCC220PK009

© 2007 Funai Electric Co., Ltd.

All rights reserved. No part of this manual may be reproduced, copied, transmitted, disseminated, transcribed, downloaded or stored in any storage medium, in any form or for any purpose without the express prior written consent of Funai. Furthermore, any unauthorized commercial distribution of this manual or any revision hereto is strictly prohibited.

Information in this document is subject to change without notice. Funai reserves the right to change the content herein without the obligation to notify any person or organization of such changes.

FUNAI with  is a registered trademark of Funai Electric Co., Ltd and may not be used in any way without the express written consent of Funai. All other trademarks used herein remain the exclusive property of their respective owners. Nothing contained in this manual should be construed as granting, by implication or otherwise, any license or right to use any of the trademarks displayed herein. Misuse of any trademarks or any other content in this manual is strictly prohibited. Funai shall aggressively enforce its intellectual property rights to the fullest extent of the law.