



## 'STEREOFETIC' F. M. TUNER

### SERVICING INSTRUCTIONS

The STEREOFETIC FM Tuner is best considered as four separate units :

1. The Power Supplies
2. The Front End
3. The I.F. Strip
4. The Decoder

For Service Manuals Contact  
MAURITRON TECHNICAL SERVICES  
8 Cherry Tree Rd, Chinnor  
Oxon OX9 4QY  
Tel:- 01844-351694 Fax:- 01844-352554  
Email:- enquiries@mauritron.co.uk

Items 1, 3 and 4 are on printed circuit boards which can be swung up from the chassis for ease of servicing. Item 2 is located on the chassis itself.

#### 1. THE POWER SUPPLIES (Diagrams Pages 4 & 5)

The Tuner requires +9 volts at about 90 milliamps, and -5 volts at about 5 milliamps. Both these supplies are critical with regard to voltage level and ripple. Any variation in level of the voltage lines will cause mistuning of the oscillator in the front end, and may cause limiting of the output audio signal. Any increase in ripple will cause an increase in hum level at the output of the decoder.

The stabilisation circuit for each supply consists of a series regulator driven by a constant voltage source. Each constant voltage source consists of a zener diode which controls its own current by means of a constant current transistor feeding base current back into its own transistor feeder (e.g. VT1 is a constant source feeding base current to VT2. VT2 feeds a constant current to zener diode D3, which in turn sets up to constant current in VT1. R5 acts as a starter resistor).

The output voltage from each regulator can be adjusted by about  $\pm \frac{1}{2}$  volt by varying a potentiometer which is across each zener (VR1 and VR2).

Both supplies can accept short circuits in their outputs for a few seconds without any adverse effects. Continuous short circuits will overheat the series regulators.

The voltages given on the circuit diagram refer to a 235 volt rms input voltage to the 200-250 volt tap. Other mains voltage will give different voltages for all except the +9 and -5 volt outputs. At 100 and 200 volt mains input the ripple may increase by about 30%.

DO NOT RUN THE TUNER FOR LONG PERIODS WITHOUT A FESTOON LAMP as this may cause failure of one or both of the 1,000 microfarad reservoir capacitors. This is because the festoon lamp forms a substantial part of the load on the mains transformer, and when this load is removed the voltage across the 1,000mF capacitors may rise above their maximum rating if the mains voltage is high.

#### 2. THE FRONT END (Diagrams Pages 10, 11 & 12)

The basic front-end circuit consists of an RF amplifier, mixer and separate oscillator system. It is unconventional in that a dual-gate Field Effect Transistor is used for the mixer, and the oscillator is of the grounded collector variety. THE POSITIONING OF COMPONENTS IN THIS PART OF THE TUNER IS CRITICAL. MOVEMENT OF ANY COMPONENT MAY CAUSE MISTUNING OR UNWANTED OSCILLATION.

The 75 ohm coaxial socket is isolated from chassis by two 200pf capacitors to stop any chassis currents which might otherwise cause noise or interference. The RF transistor is a single gate F.E.T. to which AGC is applied when the input signal exceeds 1 millivolt. This stage can accept several hundred millivolts without overloading. Both input and output are tuned by simple LC networks, and the tuned output is fed into gate 1 of the mixer. The oscillator input is fed into gate 2 (L3 & C18 form a 10.7MHz trap to increase the mixer efficiency).

The mixer output is transformed through a double tuned 10.7MHz transformer and fed to a capacitance divider and thence to the I.F. Strip.

The oscillator feeds out about 500 millivolts rms from its capacitor at 100MHz. This decreases to about 400 millivolts at 120MHz.

The AFC rate is 2.7 millivolts per kHz change in tuning, and gives an overall AFC of  $2\frac{1}{2} : 1$ .

### 3. THE I.F. STRIP (Diagrams Pages 8 & 9)

The I.F. Strip can be considered in two sections :

- (a) The 10.7MHz amplifier and detector
- (b) The muting and indicator system

For Service Manuals Contact  
**MAURITRON TECHNICAL SERVICES**  
8 Cherry Tree Rd, Chinnor  
Oxon OX9 4QY  
Tel:- 01844-351694 Fax:- 01844-352554  
Email:- enquiries@mauritron.co.uk

#### The 10.7MHz Signal Path and Detector

Two integrated circuits and two ceramic filters form the main 10.7MHz signal path, and as these are very reliable components, the I.F. strip should give many years of trouble-free service. The ceramic filters are factory-tuned and non-adjustable, the exact centre frequency being indicated by a coloured dot on the top of each filter. If one of these devices requires replacement it is essential that the new filter is of the same colour so that its centre frequency matches the remaining filter in the strip. This frequency will probably not be exactly 10.7 MHz: it can be determined by feeding about 25 microvolts of unmodulated R.F. into the I.F. strip via C35 and watching the tuning meter as the signal generator frequency is manually swept through the 10.7MHz region. Maximum meter reading coincides with the filter centre frequency. If the tuning meter is not functioning, then a minimum voltage reading at the collector of VT13 also coincides with the filter centre frequency.

The input transistor VT10 acts as an impedance match from the output of the "front-end" to the first filter (both filters require 300 ohm matching in and out). The overall gain from I.F. strip input to 1st I.C. input is about 0dB, as the transistor gain of 10dB compensates for the filter insertion loss of about -10dB. The AGC amplifier should give about -1 volt d.c. out for 3 millivolts of 10.7MHz fed into the I.F. strip input.

The overall circuit gain from input to audio output should be such that about 4 microvolts of fully modulated 10.7MHz at the input will produce about 120 millivolts of audio output with a signal/noise ratio of better than 30dB. The primary of the ratio detector is tuned for minimum audio distortion, and the secondary for zero d.c. volts at the AFC take-off point. It should be noted that this primary tuning does not necessarily coincide with maximum d.c. volts across C63: unless the proper distortion measuring apparatus is available the ratio detector cores should not be touched. Likewise, as the AFC volts are so low compared with most other ratio detectors, and are fed from a high impedance, the secondary tuning should be adjusted only if a high input impedance digital voltmeter is available.

#### The Muting and Indicator System

The mute operates in two ways—it feeds a wideband inhibit signal to pin 3 of the second I.C., and it feeds a narrow band inhibit signal to the audio amplifier in the decoder. The wideband inhibit signal is derived directly from the 10.7MHz signal which appears at the output of the second I.F. filter. This signal is amplified by VT12 and rectified by D8 and D9. The rectified output is fed onto the base of VT13 such that if the 10.7MHz input to the I.F. strip exceeds about 40 microvolts VT13 switches on. Thus, D10 ceases to conduct current into pin 3, and I.C.2 switches on too. The actual level at which VT13 switches on can be controlled by VR7.

The narrow band signal is derived from the AFC signal and helps to reduce the edge-of-the-station "plop" which is common in a lot of muting systems. The d.c. output from the ratio detector is fed via VT17 into one side of the differential pair VT18 and VT19. The output voltage from this pair is rectified by D11 and D12 so that the voltage to R50 is unidirectional each side of the ratio detector centre-tuning point. Thus, a peak voltage is produced by the differential pair, the actual peak coinciding with true centre tuning. (The position of this peak is adjusted by VR4 to balance the offset caused by the  $V_{be}$  of VT17). The wideband signal from VT13, and the peak signal from VT18 and VT19 are summed into VT14, 15 and 16, so that the output voltage from VT16 drops from +8 volts to +0.8 volts at centre-tuning, and the output voltage from VT15 changes from +1 volt to +2.5 volts. (This voltage swing is set by adjusting VR3).

The point at which the mute is removed is dependent upon the output from VT16, and the ratio between the wideband and narrow band voltage levels at this point is set by the ratio between R48 and R50, and between R61 and R60. To ensure that the "plop" is kept to a low value, while at the same time keeping a reasonably wide tuning range, the volts at "MUTE 3" drop to about  $5\frac{1}{2}$  at the edge of the band (when the meter jumps to halfway up the black band), and down to  $3\frac{1}{2}$  before the audio circuits can pass signals.

The indicator system is fed directly from VT15 via a 5.6K ohm resistor (R58). It therefore reads a true peak when the detector is set to the exact centre of the tuning range. This coincides with the minimum distortion point. However, because this centre peak is a relatively narrow part of the ratio detector pass band, for ordinary domestic listening it is sufficient to tune only into the wide band range such that the demute operates satisfactorily. Over this range the audio distortion will be less than 1% for most average music programmes.

#### 4. THE DECODER (Diagrams Pages 6 & 7)

The decoder switches automatically from mono to stereo unless the mono lock button is in, in which case the 38kHz doubler (VT21) is locked off. The audio signal comes straight from the I.F. strip via a large isolating capacitor (C74) and a 19kHz trap (L5 and C75) into a summing amplifier VT22. The mute signal from MUTE 3 inhibits VT22 via the mute switch, and a "stereo only" signal can also inhibit it if required via the "stereo only" switch. VT22 has a gain of 3, and feeds the audio signal into one side of the switching system IC3.

In the absence of a 38kHz switching signal IC3 acts as two pairs of differential amplifiers fed with variable current via the two current sources. Thus, at the two collector resistors R88 and R94 there appear two identical in-phase audio voltages, each about 300mV rms for 75kHz deviation. These audio signals are de-emphasised by C84 and C87 and feed to the left and right hand audio channels.

Each channel consists of a 19kHz low pass filter followed by a 38kHz trap and low output impedance output stage. The filter voltage gain is unity, and the output amplifier gain is 3, giving an overall decoder gain of about 18 to 20dB. The filter system is a simple second-order filter preceded by a 6dB per octave RC network (R100 and C90) with an overall 3dB point of 19kHz. This gives a flat response up to 17kHz, and an attenuation rate of 18dB per octave above 21kHz. The output amplifier has an output impedance of about 200 ohms, but due to standing current limitations will not feed a full deviation signal into loads of less than 750 ohms.

When a 19kHz pilot tone is present at the input, it is amplified by VT20, tuned by L6 and C77 and frequency doubled by VT21, L7 and C82. The resulting 38kHz signal is applied to the bases of the two differential pairs of IC3 so that the output collectors are alternately switched synchronously with the multiplex input signal. Thus, a right hand signal appears at pin 12 and a left hand signal at pin 11. The inherent crosstalk between left and right channels caused by square-wave decoding the signal is cancelled by the cross-feed network R89, R90, R91 and VR6.

The stereo-beacon signal is derived from the 38kHz doubler output, which is rectified and used to switch VT24 on. This d.c. voltage is then used to add a bias to the meter indicator, pulling it into the red region for stereo, and to act as a demuting signal to VT22 if the "stereo only" button is in.

The quasi-stereo switches cross-couple left and right channel signals via frequency selective networks C96 and C97 in conjunction with R100L and R100R. Thus, at higher frequencies the left and right channels mix, while at lower frequencies they remain separate, the actual changeover frequencies depending on the values of C96 and C97.

The variable resistor VR5 feeds an out-of-phase 19kHz signal into VT22 which helps to reduce the pilot tone breakthrough of the system.

When setting up the decoder, the following method has been found to be quick and simple :-

1. Feed in an R-L signal without pilot tone and adjust L7 for minimum output.
2. Add pilot tone to the R-L signal and tune L6 for maximum output from R and L channels. (N.B.— There are two tuning points, but one of them will reverse the channels, so check with R or L only signal).
3. Tune L5 and VR5 for maximum rejection of 19kHz at outputs.
4. Tune L8L and L8R for maximum rejection of 38kHz at outputs.
5. Adjust VR6 for best cross-channel separation by feeding in either R only or L only signal plus pilot.

For Service Manuals Contact  
MAURITRON TECHNICAL SERVICES  
8 Cherry Tree Rd, Chinnor  
Oxon OX9 4QY  
Tel:- 01844-351694 Fax:- 01844-352554  
Email:- enquiries@mauritron.co.uk

For Service Manuals Contact  
**MAURITRON TECHNICAL SERVICES**  
 8 Cherry Tree Rd, Chinnor  
 Oxon OX9 4QY  
 Tel: 01844-351694 Fax: 01844-352554  
 Email: enquiries@mauritron.co.uk

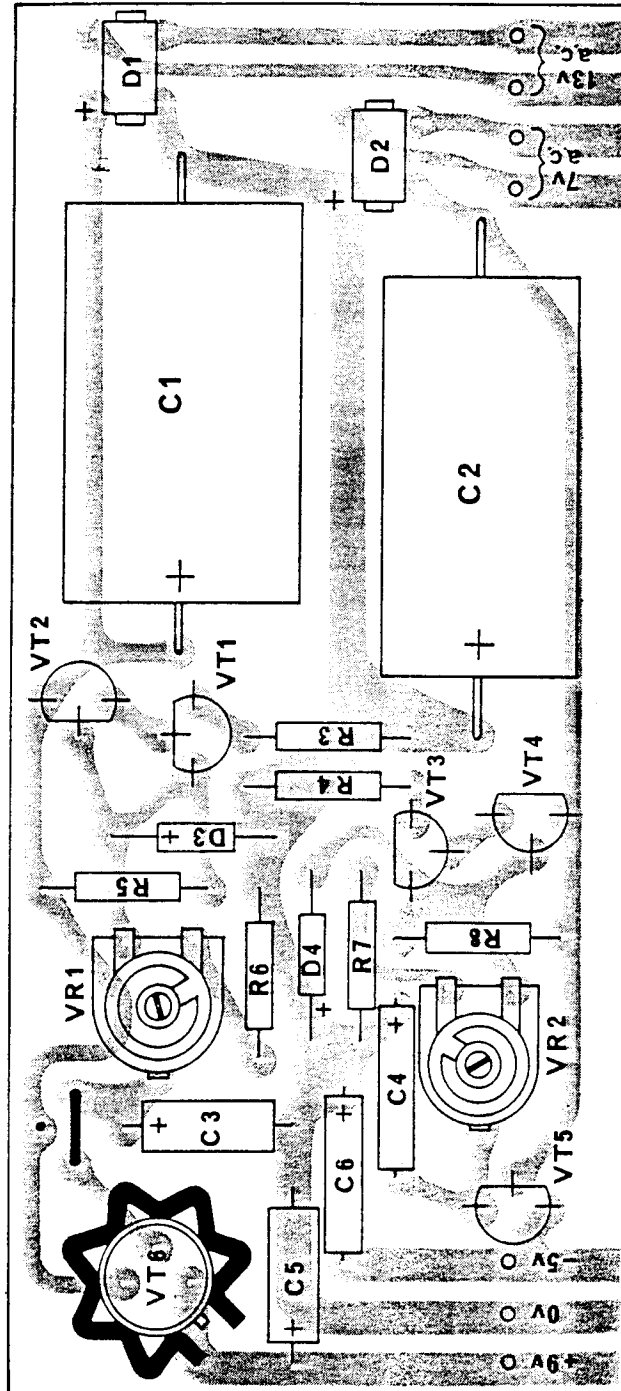

POWER SUPPLIES CIRCUIT BOARD  
 LAYOUT DIAGRAM

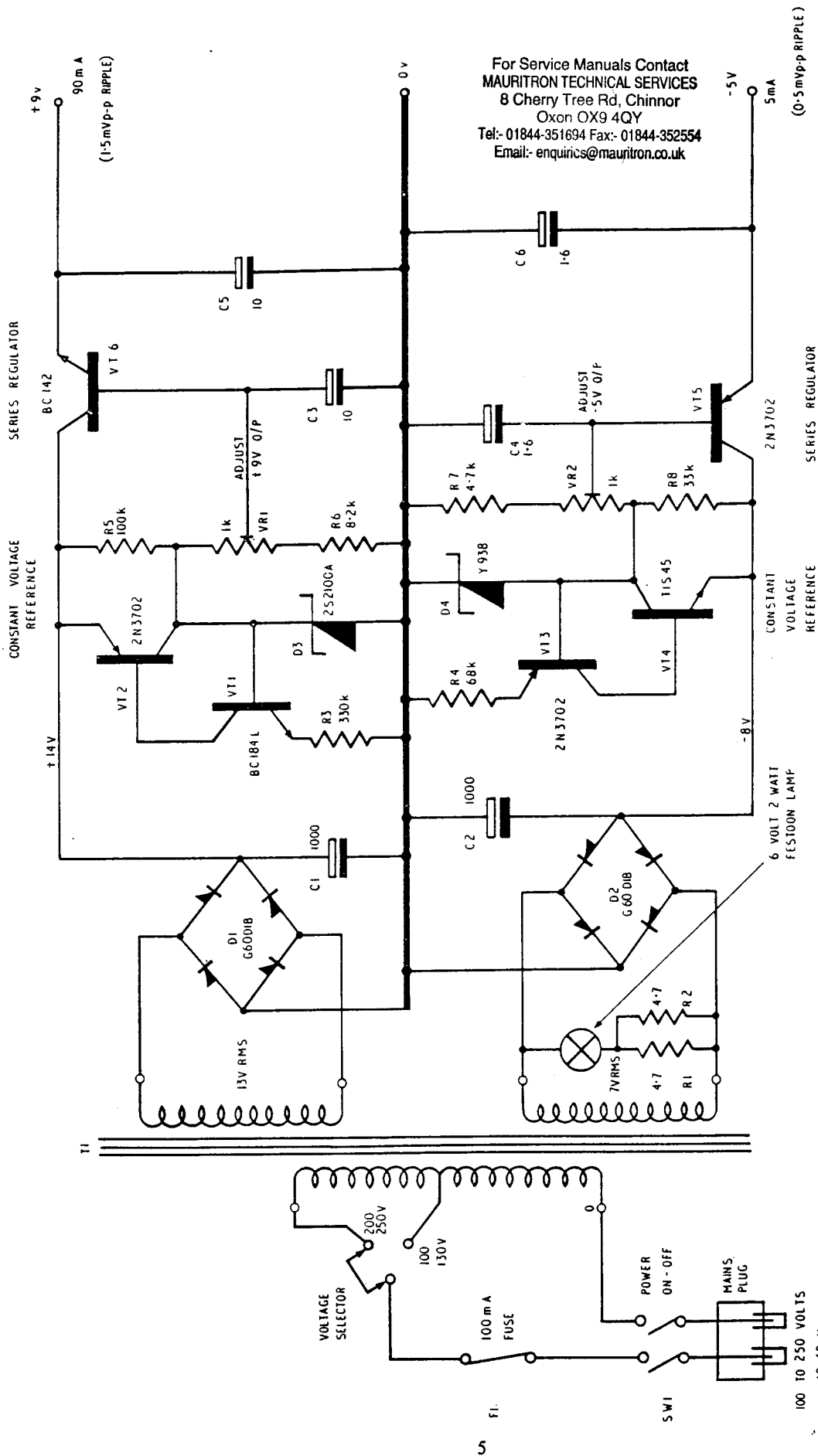

RESISTOR VALUES IN OHMS UNLESS OTHERWISE SHOWN  
 CAPACITOR VALUES IN MICROFARADS UNLESS OTHERWISE SHOWN  
 VOLTAGES ARE MEASURED USING A METER OF 20,000Ω/VOLT

POWER SUPPLIES CIRCUIT DIAGRAM

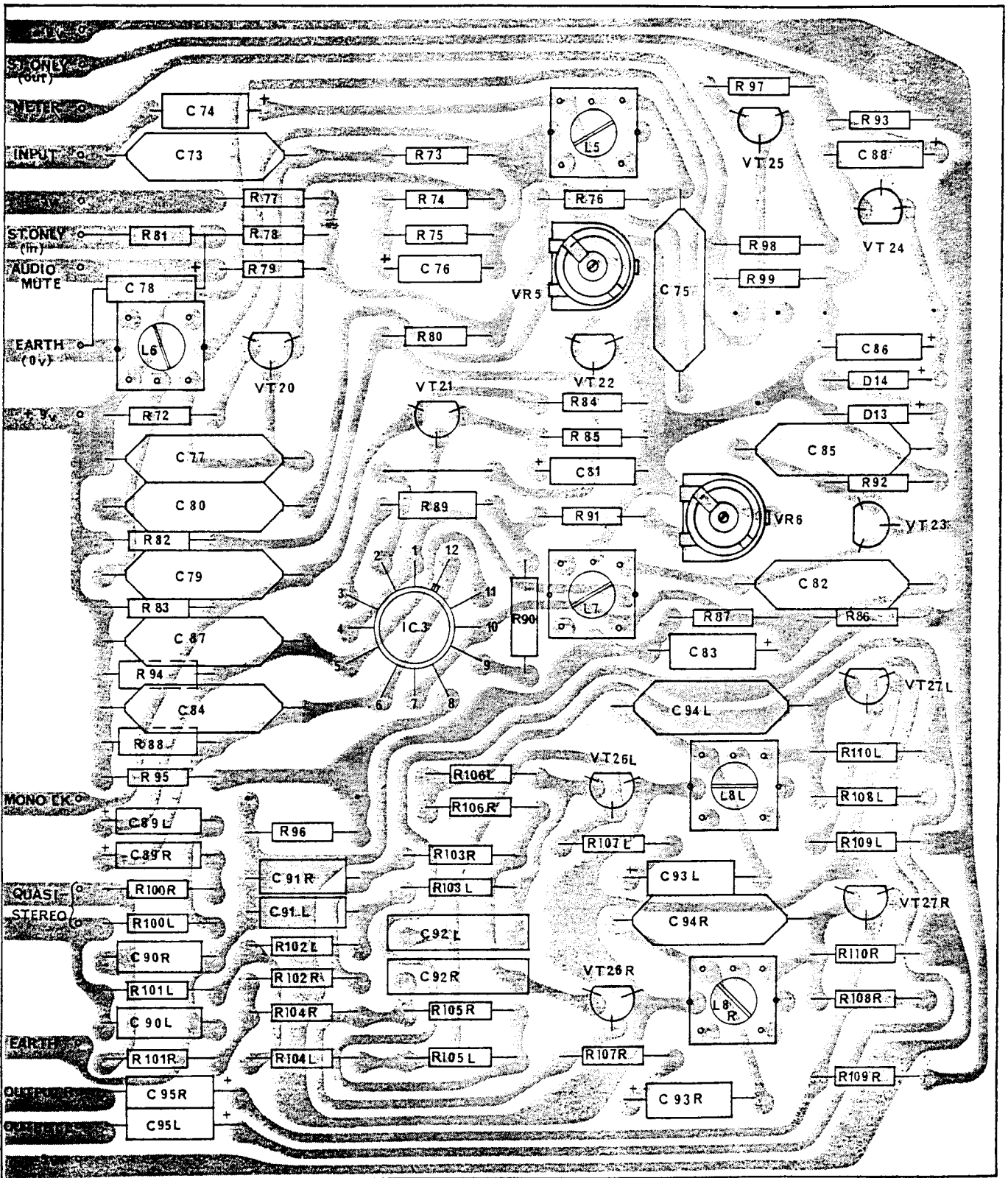

DECODER CIRCUIT BOARD  
LAYOUT DIAGRAM

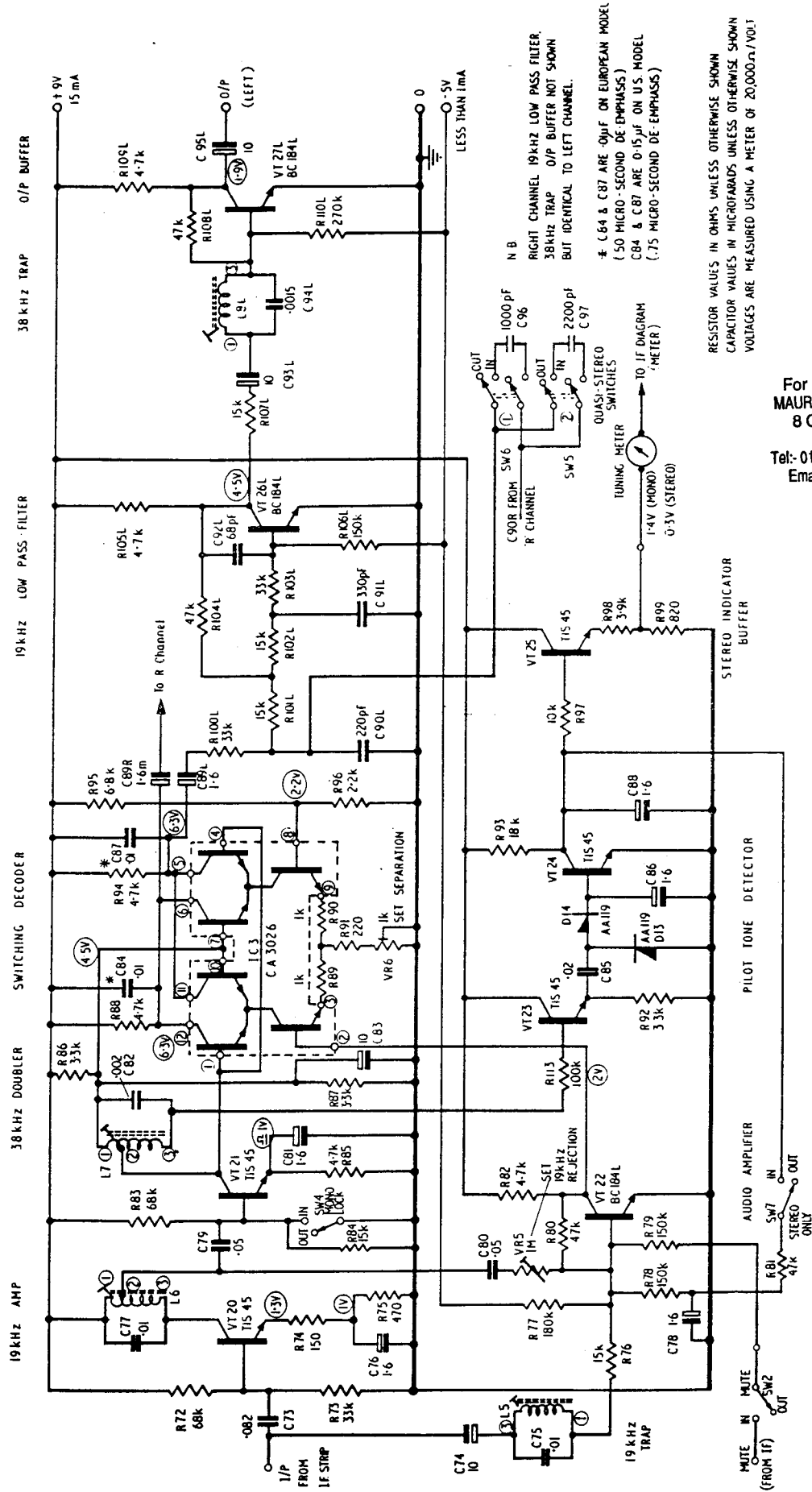

N.B.  
RIGHT CHANNEL 19KHZ LOW PASS FILTER,  
38KHZ TRAP O/P BUFFER NOT SHOWN  
BUT IDENTICAL TO LEFT CHANNEL.

\* C84 & C87 ARE 0.01µF ON EUROPEAN MODEL  
(.50 MICRO-SECOND DE-EMPHASIS)  
C84 & C87 ARE 0.15µF ON U.S. MODEL  
(.75 MICRO-SECOND DE-EMPHASIS)

RESISTOR VALUES IN OHMS UNLESS OTHERWISE SHOWN  
CAPACITOR VALUES IN MICROFARADS UNLESS OTHERWISE SHOWN  
VOLTAGES ARE MEASURED USING A METER OF 20,000Ω/V/VOLT

For Service Manuals Contact  
**MAURITRON TECHNICAL SERVICES**  
8 Cherry Tree Rd, Chinnor  
Oxon OX9 4QY  
Tel:- 01844-351654 Fax:- 01844-352554  
Email:- enqinics@mauritron.co.uk

DECODER CIRCUIT DIAGRAM

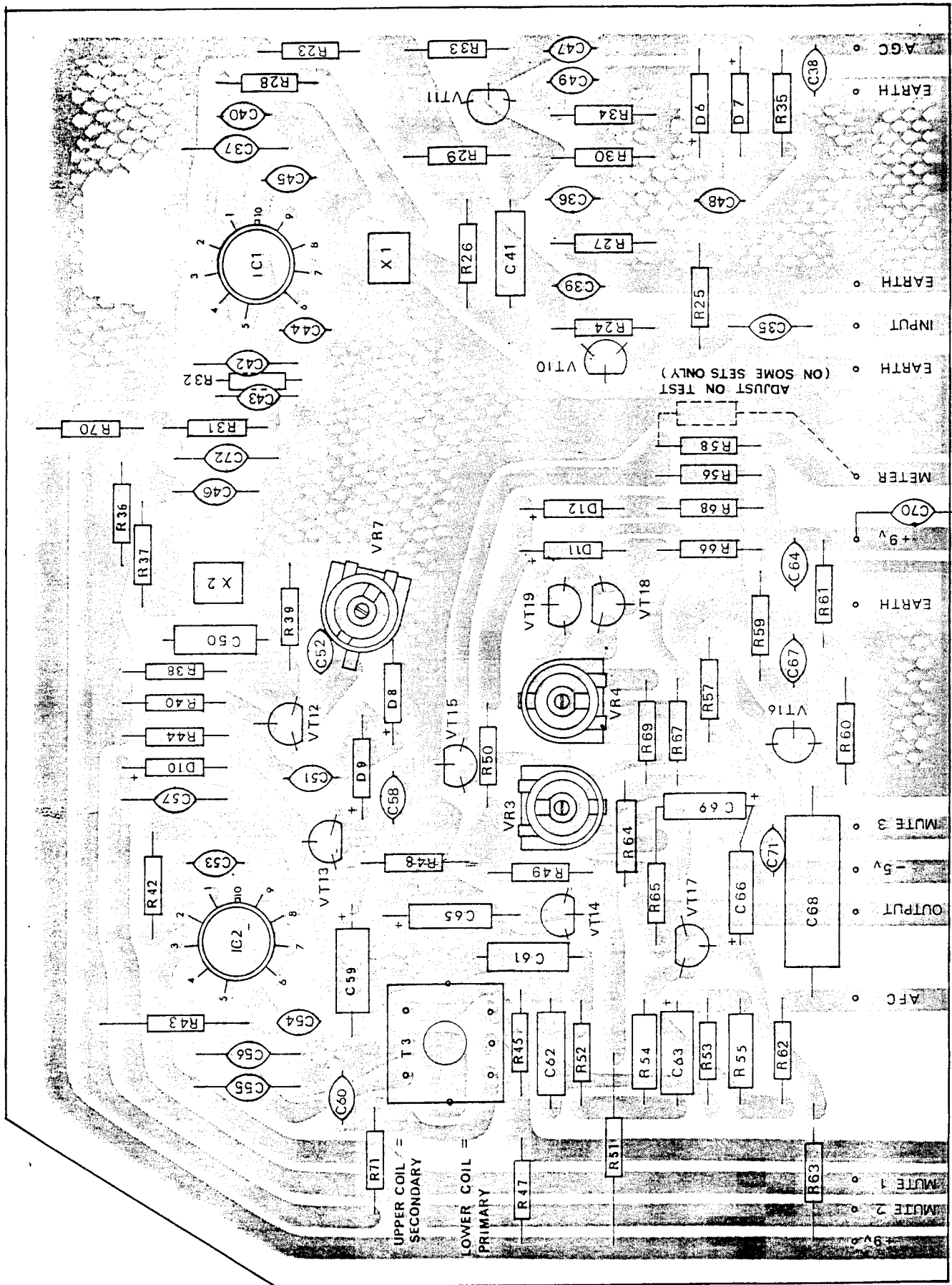

IF STRIP CIRCUIT BOARD LAYOUT DIAGRAM



For Service Manuals Contact  
**MAURITRON TECHNICAL SERVICES**  
 8 Cherry Tree Rd, Chinnor  
 Oxon OX9 4QY  
 Tel: 01844-351694 Fax: 01844-352554  
 Email: enquiries@mauritron.co.uk

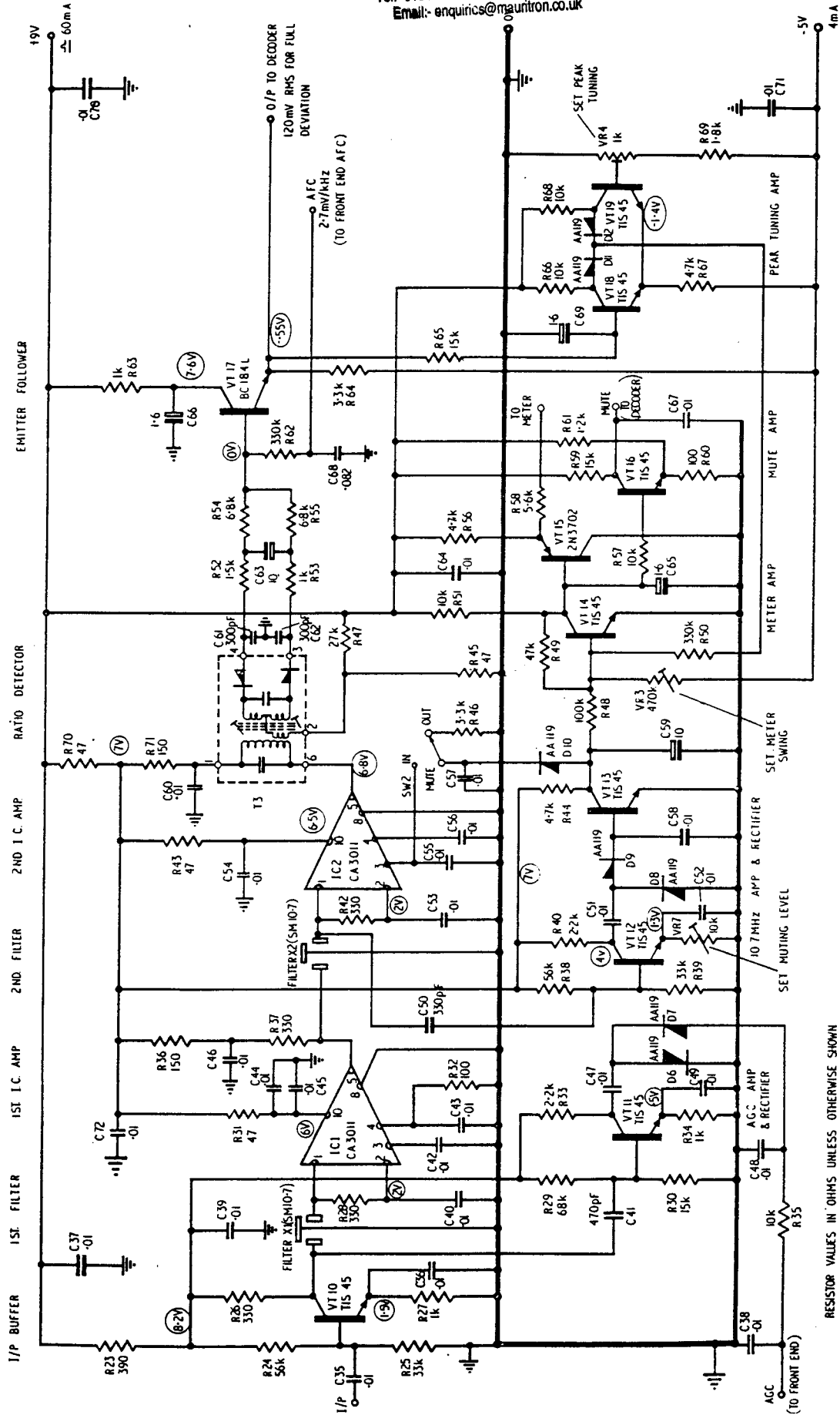

IF STRIP CIRCUIT DIAGRAM

RESISTOR VALUES IN OHMS UNLESS OTHERWISE SHOWN  
 CAPACITOR VALUES IN MICROFARADS UNLESS OTHERWISE SHOWN  
 VOLTAGES ARE MEASURED USING A METER OF 20,000 Ω/VOLT

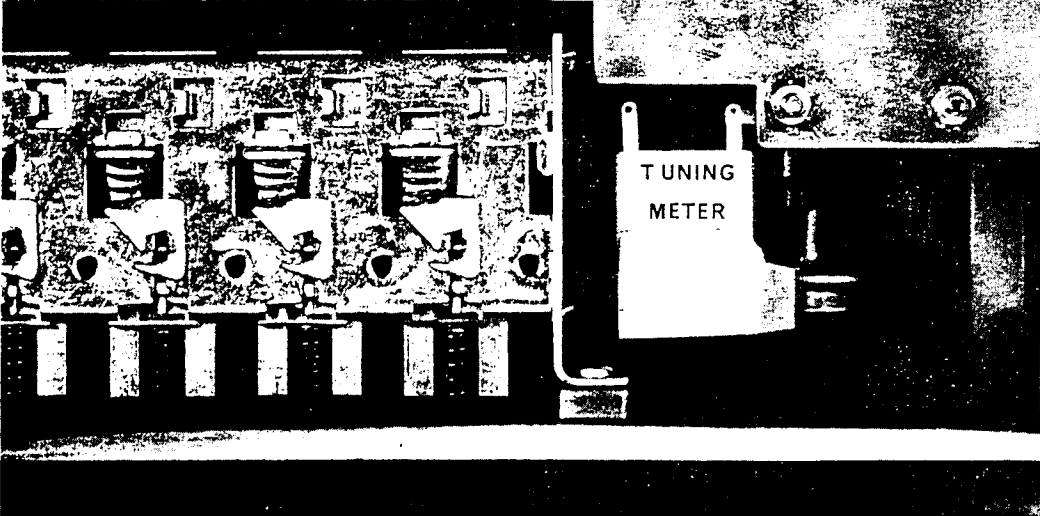
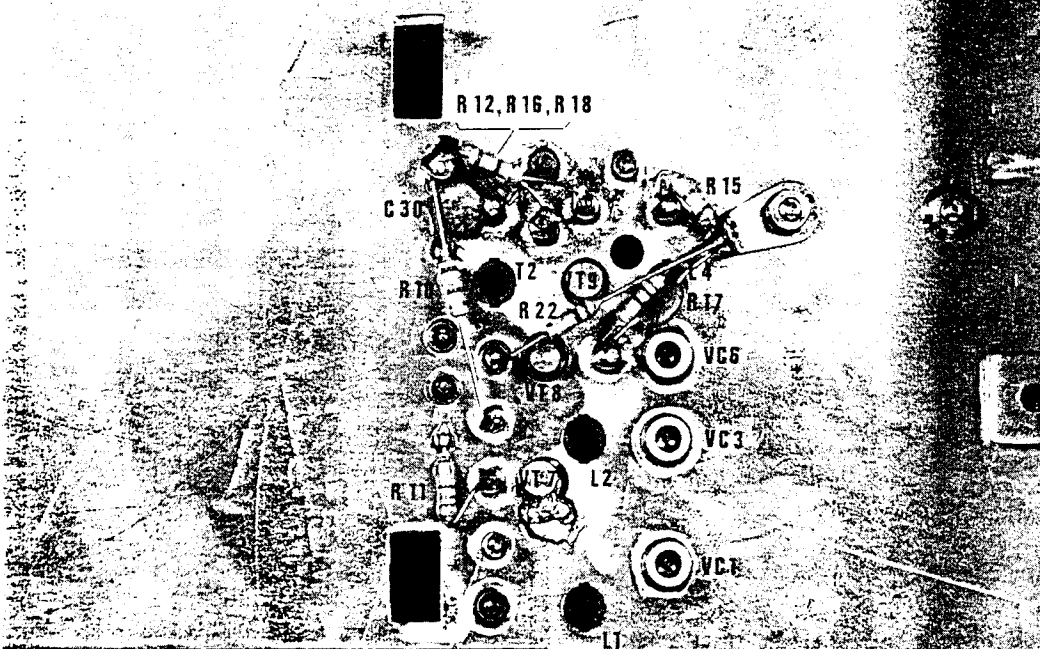
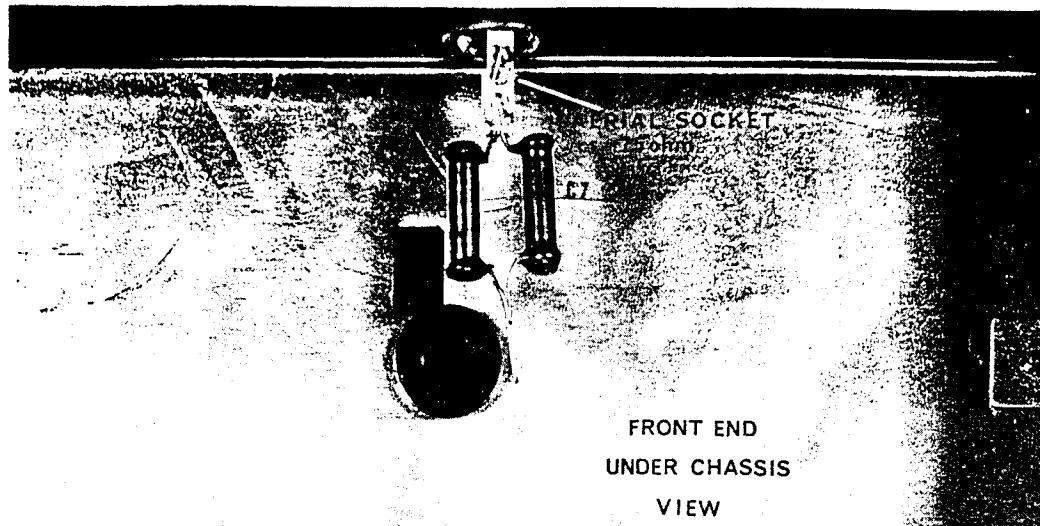

FRONT END LAYOUT UNDER CHASSIS VIEW

7

For Service Manuals Contact  
**MAURITRON TECHNICAL SERVICES**  
 8 Cherry Tree Rd, Chinnor  
 Oxon OX9 4QY  
 Tel:- 01844-351694 Fax:- 01844-352554  
 Email:- enquiries@mauritron.co.uk

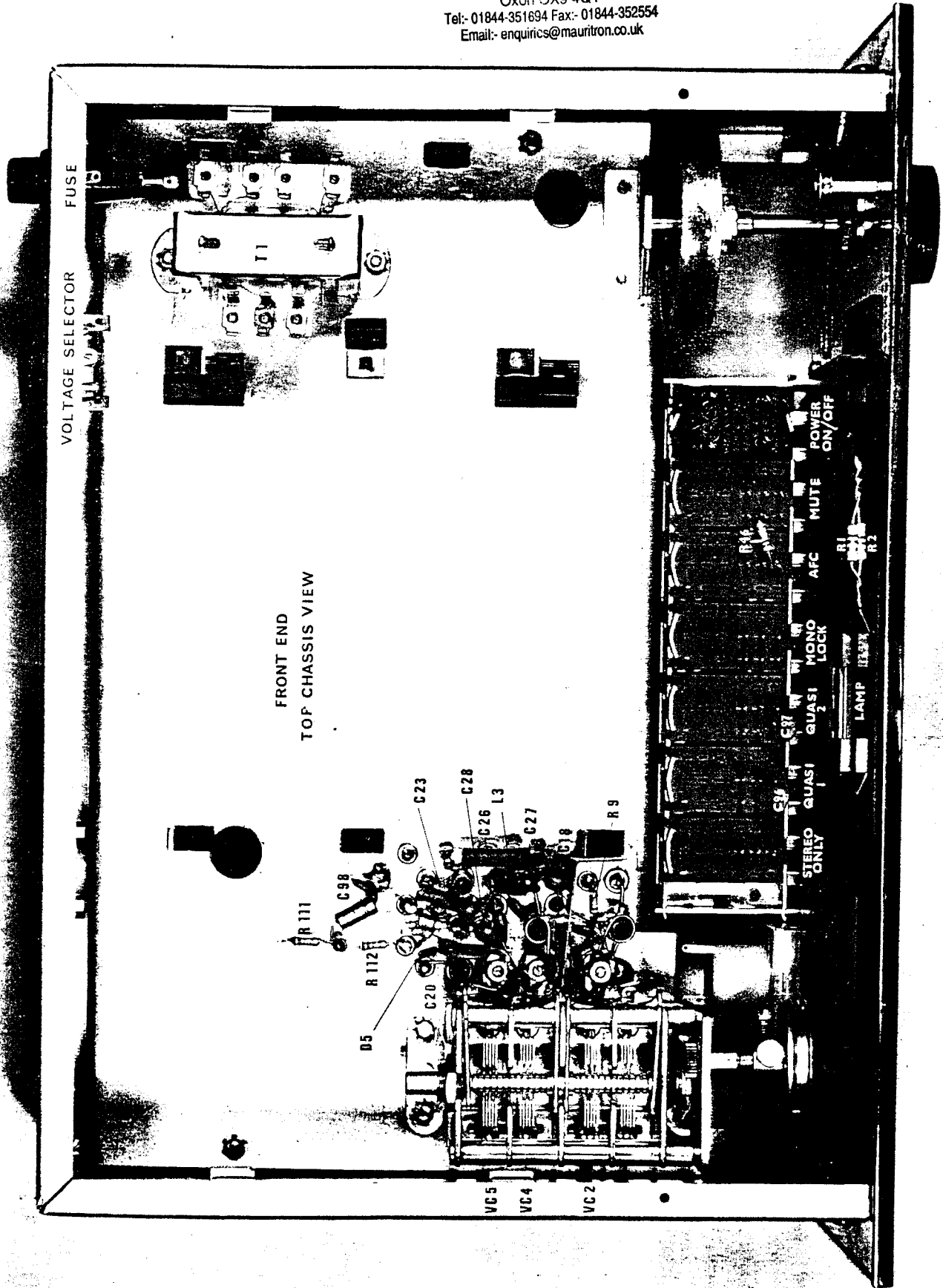

FRONT END  
 TOP CHASSIS VIEW

FRONT END LAYOUT TOP CHASSIS VIEW

For Service Manuals Contact  
**MAURITRON TECHNICAL SERVICES**  
 8 Cherry Tree Rd, Chinnor  
 Oxon OX9 4QY  
 Tel:- 01844-351694 Fax:- 01844-352554  
 Email:- enquiries@mauritron.co.uk

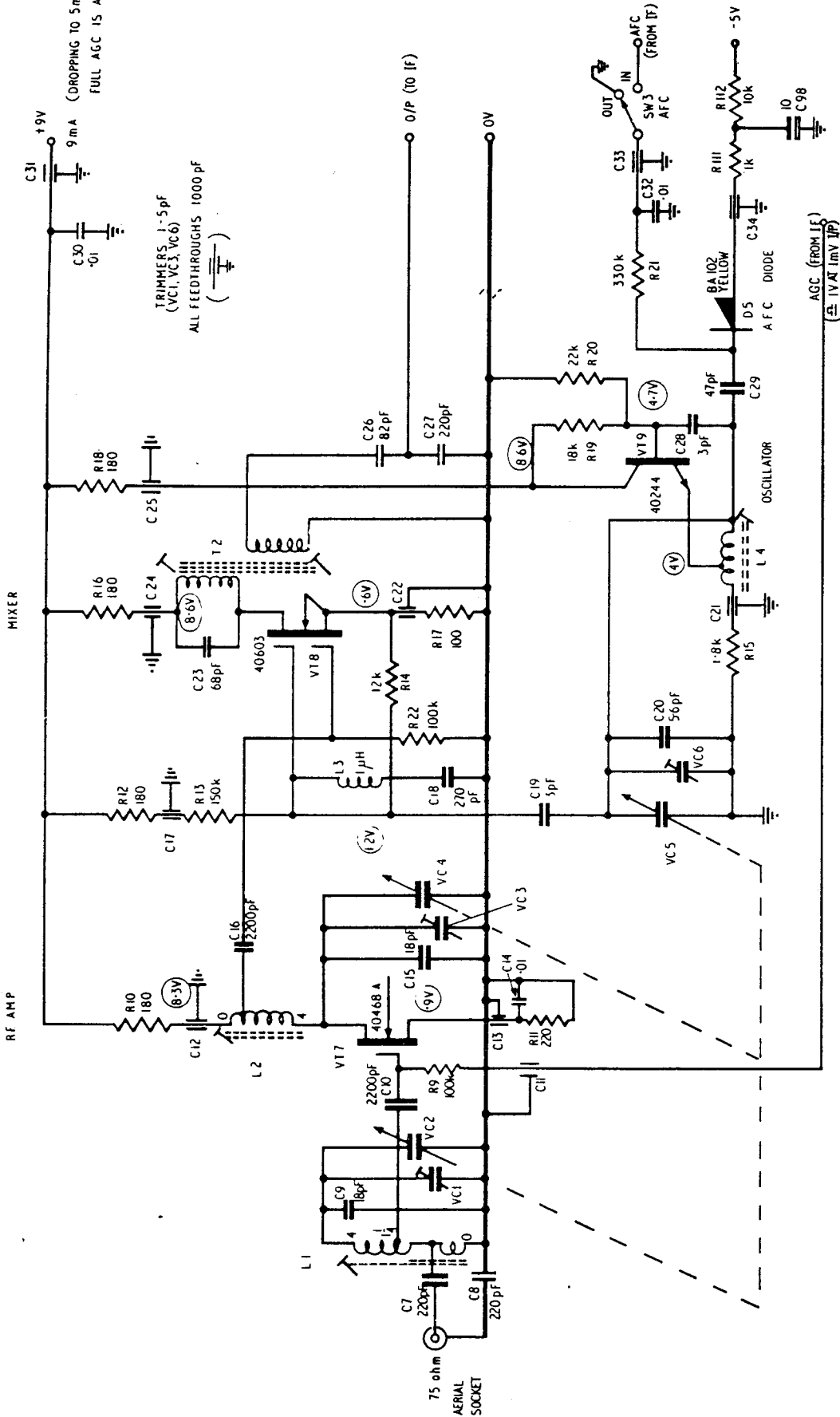

RESISTOR VALUES IN OHMS UNLESS OTHERWISE SHOWN  
 CAPACITOR VALUES IN MICROFARADS UNLESS OTHERWISE SHOWN  
 VOLTAGES ARE MEASURED USING A METER OF 20,000Ω/VOLT

FRONT END CIRCUIT DIAGRAM

**H. J. LEAK & CO. LTD.**  
 BRUNEL ROAD,  
 WESTWAY FACTORY ESTATE,  
 LONDON, W.3

Telephone: 01-7-9 1641 (10 lines)

H. J. LEAK & CO. LTD., a member of the Rank Organisation

