

This Manual Also Covers 24R,  
And 25R Console Chassis

# Service Manual

# THE FISHER®

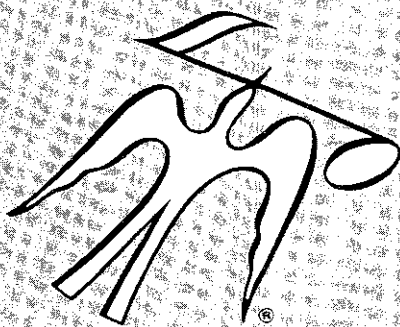
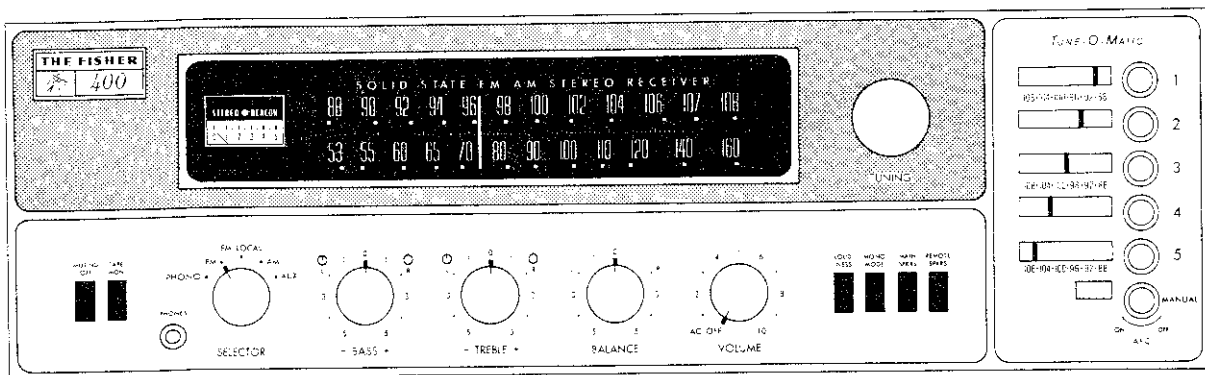
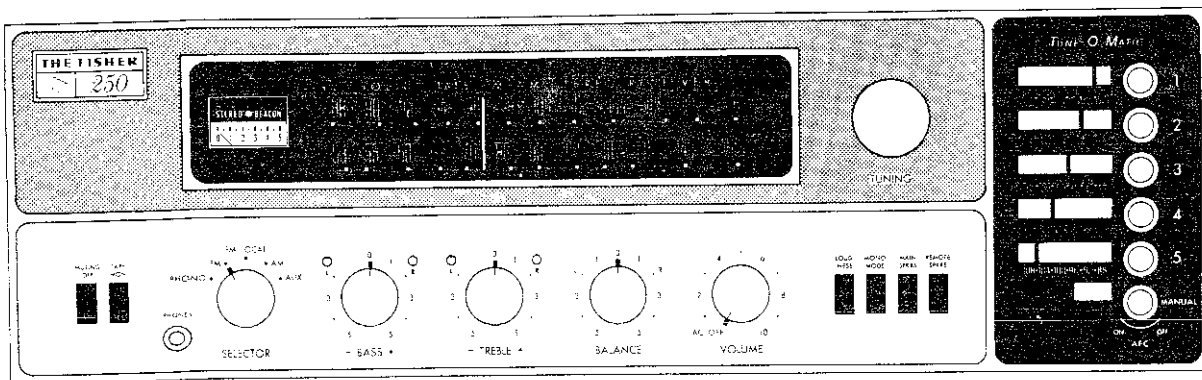

## 250-T™

CHASSIS SERIAL NUMBERS  
BEGINNING 10001

## 400-T™

CHASSIS SERIAL NUMBERS  
BEGINNING 10001

PRICE \$1.00

FISHER RADIO CORPORATION • 11-40 45th ROAD • LONG ISLAND CITY, N.Y. 11101

## REQUIRED TEST EQUIPMENT

The following equipment is required to completely test and align modern high-fidelity amplifiers, tuners, and receivers.

Line Voltage Autotransformer or Voltage Regulator	10.7 MHz Sweep Generator
DC Vacuum Tube Voltohmmeter	Multiplex Generator (preferably with RF output — FISHER 300)
Accurately Calibrated AC Vacuum Tube Voltmeter	455 kHz Sweep Generator
Oscilloscope (Flat to 100 kHz Minimum)	Ferrite Test Loop Stick
Low-Distortion Audio (Sine Wave) Generator	2 — Full Range Speakers for Listening Tests
Intermodulation Distortion Analyzer	Stereo Source — Turntable, Tape Recorder, etc.
Harmonic Distortion Analyzer	Soldering Iron with Small Tip, Fully Insulated from AC Line
2 — Load resistors, 8-Ohms, 100 Watt (Minimum Rating)	Suction Desoldering Tool
AM/FM Signal Generator	

**CAUTION:** This precision high-fidelity instrument should be serviced only by qualified personnel, trained in the repair of transistor equipment and printed circuitry.

Many of these items are included only as a reminder — they are normal procedures for experienced technicians. Shortcuts may be taken, but these often cause additional damage to transistors, circuit components, or printed circuit boards.

**SOLDERING:** A well-tinned, hot, clean soldering iron tip will make soldering easier, without causing damage to the printed circuit board or the components mounted on it. Regular use of a sponge cleaner will maintain a clean soldering surface. The heat available at the tip, (not the wattage of the iron) is important. Some 50-watt irons reach temperatures of 1,000° F, while others will hardly melt solder. Small-diameter tips should be used for single solder connections, pyramid and chisel tips for large areas.

Always disconnect the AC power cord from the line when soldering. Turning the power switch OFF is not sufficient. Power-line leakage paths, through the heating element of the iron, may destroy transistors.

**PARTS REMOVAL:** If a part is not being returned for in-warranty factory replacement, it may be cut in half (with diagonal cutting pliers) to make removal easier. Multiple terminal parts, such as IF transformers, or electrolytic capacitors, should be removed using special de-soldering tips made especially for this purpose. Removing solder from terminals, reduces the possibility of breaking the printed circuit board when the part is removed.

**ACCIDENTAL SHORTS:** A clean working area, free of metal particles, screws, etc., is an important preventive in avoiding servicing problems. Screws, removed from the chassis during servicing, should be stored in a box until needed. While a set is operating, it takes only an instant for a base-to-collector short to destroy a transistor (and others direct-coupled to it). In the time it takes for a dropped machine screw, washer, or screwdriver, to contact a pair of socket terminals (or terminal and chassis), a transistor can be ruined.

**SOLID-STATE DEVICES:** Integrated Circuits contain the equivalent of many circuit parts, including transistors, diodes, resistors, and capacitors. The preferred troubleshooting procedure requires isolating the trouble to one stage using AC signal tracing methods. Once the suspected stage is located, the DC voltages at the input and output leads are measured to give an accurate indication of the operating conditions of the IC. DO NOT use an ohmmeter to check continuity with the IC mounted on the printed circuit board. Forward biasing the internal junctions within the IC may burn out the transistors. Do not replace a defective IC until all external resistors, capacitors, and transformers are checked first, to prevent the replacement IC from failing immediately due to a defect in the connecting components. Solder and unsolder each lead separately using a pliers or other heat sink on the lead to prevent damage from excessive heat. Check that the leads are

connected to the correct locations on the printed circuit board before turning the set on.

Whenever possible, a transistor tester should be used to determine the condition of a transistor or diode. Ohmmeter checks do not provide conclusive data, and may even destroy the junction(s) within the device.

Never attempt to repair a transistor power amplifier module until the power supply filter-capacitors are fully discharged.

If an output or driver transistor becomes defective (opens or shorts), always check ALL direct-coupled transistors and diodes in that channel. In addition, check the bias pot., and other parts in the bias network, before installing replacement transistors. All output and driver transistors in one channel may be destroyed if the bias network is defective. After parts replacement, always check the bias adjustment for specified idling current.

In some applications, replacement of transistors must be made from the same beta group as the original type. The beta group is indicated by a colored marking on the transistor. Be sure to include this information when ordering replacement transistors.

When mounting a replacement power transistor, be sure the bottom of the flange, mica insulator, and the surface of the heat sink, are free of foreign matter. Dust and grit will prevent flat contact, reducing heat transfer to the heat sink. Metallic particles can puncture the insulator, cause a short, and destroy the transistor.

Silicone grease must be used between the transistor and the mica insulator, and between the mica and the heat sink, for best heat transfer. Use Dow-Corning DC-3, or an equivalent compound made for power transistor heat conduction.

Use care when making connections to speakers and output terminals. To reduce the possibility of shorts, lugs should be used on the exposed ends, or stranded wire should be tinned to prevent frayed wire ends. Current in the speakers and output circuitry is quite high — poor contacts, or small sized wire, can cause significant power losses in the system. For wire lengths greater than 30 feet, 16 AWG, or heavier, should be used.

**VOLTAGE MEASUREMENTS:** All voltages are measured with the line voltage adjusted to 120 volts. All measured voltages are  $\pm 10\%$ . DC voltages are measured to ground with a VTVM, with no signal input unless otherwise noted. AC signal voltages are measured under the conditions specified on the schematic.

**ALIGNMENT PROCEDURES:** DO NOT attempt realignment unless the required test equipment is available, and the alignment procedure is thoroughly understood.

BECAUSE ITS PRODUCTS ARE SUBJECT TO CONTINUOUS IMPROVEMENT, FISHER RADIO CORPORATION RESERVES THE RIGHT TO MODIFY ANY DESIGN OR SPECIFICATION WITHOUT NOTICE AND WITHOUT INCURRING ANY OBLIGATION.

## SERVICE PROCEDURES

### REMOVING DRESS PANEL

- (1) Disconnect A C power cord.
- (2) Remove the screws which hold the top and bottom covers to the chassis. (On 250-T, 24R chassis, also remove screws holding top cover to heat sink.) Remove the covers.
- (3) Gently pull the eight leads off the terminal pins behind the TUNE-O-MATIC dial assembly. These push-on terminal leads connect the panel-mounted dial assembly to the chassis circuitry and must be disconnected in order to remove the dress panel. Label each lead with its associated pin location to make replacement easier later.
- (4) Gently pull all knobs off the front dress panel control shafts. Remove the hex nuts from the shafts and remove panel by pulling forward over the shafts.
- (5) Reverse procedure for reassembly.

### REMOVING DIAL GLASS ASSEMBLY

- (1) Remove dress panel. Refer to REMOVING DRESS PANEL procedure.
- (2) Gently pull the four leads from the terminal pins on the top rear of the meter and label each lead with its associated pin location for easy replacement later.
- (3) Gently pull the two pairs of dial lamp leads from the terminal pins on the chassis and label each lead.
- (4) Gently pull the pair of meter leads from the terminal pins on the chassis and label.
- (5) Remove the screws holding the dial glass panel. Remove the panel with the dial glass, pilot lamps, and meter attached by tilting out the bottom of the panel and sliding downward. Be careful to avoid deforming dial pointer.
- (6) Reverse the procedure for reassembly.

### REMOVING DIAL GLASS ASSEMBLY

- NOTE:** The compartmented lamp assembly (FRC Part No. M21C604-2), mounted on the rear of the meter, contains the meter lamp and the STEREO BEACON lamp, and must be replaced as a complete unit.
- (1) Disconnect A C power cord.
  - (2) Remove the screws which hold the top cover to the chassis. (On 250-T, 24R chassis, also remove screws holding top cover to heat sink.) Remove the cover.
  - (3) Gently pull the four wires off the terminal pins on the top rear of the meter. Label each wire with its associated pin location to make replacement easier later.
  - (4) Gently unsnap the compartmented lamp assembly from the top rear of the meter.
  - (5) Center the replacement lamp assembly between the plastic flanges and press firmly into place.
  - (6) Reconnect the four wires to their associated terminal pins on the replacement lamp assembly.
  - (7) Replace the top cover on the chassis and secure with the screws removed previously.

### REPLACING DIAL LAMPS

- (1) Remove dress panel. Refer to REMOVING DRESS PANEL procedure.
- (2) Snap out the defective lamp from the spring clip. Place the new lamp in the socket making sure that the unpainted side of the lamp faces the edge of the dial glass.
- (3) Replace the front dress panel and secure with the hex nuts removed previously. Replace the knobs on the control shafts.
- (4) Reconnect the terminal leads (removed previously) to their respective terminal pins behind the TUNE-O-MATIC assembly.

### REPLACING METER

- (1) Remove dress panel. Refer to REMOVING DRESS PANEL procedure.
- (2) Remove dial glass assembly. Refer to REMOVING DIAL GLASS ASSEMBLY procedure.
- (3) Gently pry the meter off the dial glass panel, and scrape the residual adhesive off the panel.
- (4) Peel the backing from one side of the replacement adhesive mounting pad (FRC Part No. E51A219), and affix it to the replacement meter. Peel the backing from the remaining side of the adhesive, align the meter face over the dial panel cutout, and firmly press the meter to the back of the dial glass panel.
- (5) Remount the dial glass assembly.
- (6) Reinstall the dress panel. Reconnect all leads (removed previously) to their respective terminal pins.
- (7) Check meter calibration. Refer to TUNING METER CALIBRATION procedure.
- (8) Remount top and bottom covers removed previously.

### CLEANING FRONT PANEL

**WARNING:** Use only plain lukewarm water for moistening a freshly laundered, soft lint-free cloth to clean the front control panel.

### DIAL STRINGING

- (1) Remove dress panel. Refer to REMOVING DRESS PANEL procedure.
- (2) Remove dial pointer.
- (3) Remove dial glass assembly. Refer to REMOVING DIAL GLASS ASSEMBLY procedure.
- (4) Rotate the tuning capacitor drive-drum to its maximum CCW position. Loosen the machine screw in the center of the drive-drum and remove the old dial cord.
- (5) Tie end of new dial cord to one end of dial spring. Fasten spring to bottom right ear inside drive-drum. See Figure 1.

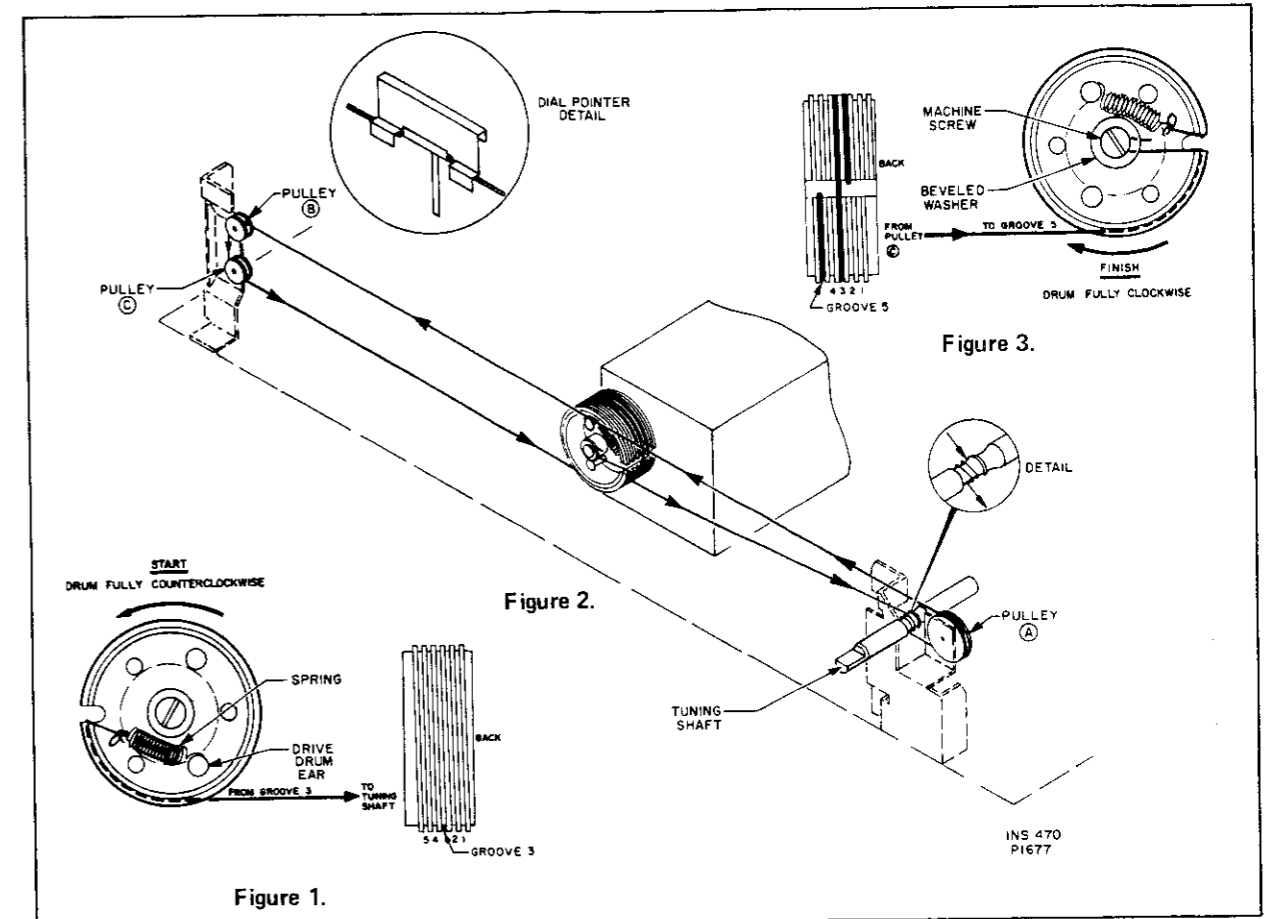

- (6) Run the dial cord through the slot in the rim of the drive-drum and set in the underside of groove 3.
- (7) Pull dial cord taut and wrap 2 turns CCW around tuning shaft. See Figure 2.
- (8) Guide the dial cord under and around pulley "A", across to the left side, down and around pulleys "B" and "C". Keep the dial cord taut during this procedure.
- (9) Rotate the drive-drum to its maximum CW position, allowing the cord to wind onto the drive-drum. Keep the dial cord taut during this procedure.
- (10) Guide the dial cord under the drive-drum and into groove 5. Bring the dial cord around groove 5 and into the slot in the drive-drum. See Figure 3.
- (11) With the machine screw loosened, place the cord under the beveled washer, pull the dial cord taut, and tighten the screw.
- (12) Turn the tuning shaft to rotate the drive-drum fully CCW and fully CW to distribute the tensioning along the dial cord.
- (13) Repeat steps (11) and (12) until dial spring is tensioned.
- (14) Remount dial glass panel assembly using the four mounting screws removed previously.
- (15) Reconnect the ten leads (removed previously) to their respective terminal pins.
- (16) Place the dial cord over and under the tabs on the rear of the dial pointer (see detail), and place the pointer on the top of the dial glass panel rail.
- (17) Turn the tuning shaft fully CCW. Slide the dial pointer to zero (0) calibration mark on the logging scale while holding tuning shaft fully CCW. Cement dial pointer to dial cord to prevent slippage. Allow cement to thoroughly dry.
- (18) Reinstall the dress panel and knobs. Reconnect the leads (removed previously) to their respective terminal pins behind the TUNE-O-MATIC assembly.
- (19) Check dial calibration. Refer to FM FRONT END ALIGNMENT and AM RF ALIGNMENT.
- (20) Remount top and bottom covers removed previously.

### REMOVING P.C. BOARDS

To remove a board from its nylon mounts, squeeze the loop of each mounting clip (using pliers), and lift each corner of the board. To remount the board, align the mounting holes over the clips, and press firmly.

### SERVICING INTEGRATED CIRCUITS

Integrated Circuits are used in this unit to approach the theoretical maximum of AM suppression and noise limiting. These IC's contain the equivalent of many circuit parts, including transistors, diodes, resistors, and capacitors. These integrated circuits are high-reliability devices, requiring minimum servicing. In the unlikely event that an IC requires servicing, it should be serviced in the same way as a transistor.

The preferred troubleshooting procedure requires isolating the trouble to one stage using AC signal tracing methods. Once the suspected stage is located, the integrated circuit can be checked by measuring the DC voltages at the input and output leads of the IC using a DC VTVM. These DC voltage measurements give the most accurate indications of the operating conditions of the integrated circuit.

**WARNING:** Do not use an ohmmeter to check continuity with the IC mounted on the printed circuit board. Forward biasing the internal junctions within the IC may burn out the transistors.

## SERVICE PROCEDURES

When replacing an integrated circuit, the following precautions should be observed:

- (1) Do not replace a defective IC until the cause of the trouble is found. All external resistors, capacitors, and transformers should be checked first to prevent the replacement integrated circuit from failing immediately due to a trouble in the connecting components.
- (2) Solder and unsolder each lead separately using a pliers or other heat sink on the lead to prevent damage from excessive heat.
- (3) Check that the leads of the replacement IC are connected to the correct locations on the printed circuit board before turning the set on.

### FUSES

In these receivers, additional safety fuses are used in the transformer secondary circuits to provide increased protection. For fuse type and rating, refer to MAIN CHASSIS schematics.

For added safety, the power amplifier modules used in these receivers are individually fused. For fuse type and rating, refer to POWER AMPLIFIER MODULE schematics.

### POWER AMPLIFIER CENTER VOLTAGE TEST

**NOTE:** Allow set to warm up at least 10 minutes before starting the following procedure.

Turn VOLUME control to minimum. Depress MAIN SPKRS pushbutton switch.

- (1) Connect DC VTVM across the LEFT SPEAKERS MAIN terminals. Meter should read 0 volt ( $\pm 100$  mV).
- (2) Connect DC VTVM across the RIGHT SPEAKERS MAIN terminals. Meter should read 0 volt ( $\pm 100$  mV).

### POWER AMPLIFIER IDLING CURRENT ADJUSTMENT

**NOTE:** Allow set to warm up at least 10 minutes before making measurements or adjustments. Power amplifier center voltage test should be performed before starting this procedure.

Turn VOLUME control to minimum.

- (1) Connect ground lead of DC VTVM to pin 8C on left channel of predriver/driver board. Connect probe of DC VTVM to pin 8Z on predriver/driver board.
- (2A) 250-T, 24R; Adjust pot. R815 (OUTPUT BIAS ADJUST) for DC VTVM reading of 18 mV.
- (2B) 400-T; Adjust pot. R815 (OUTPUT BIAS ADJUST) for DC VTVM reading of 15 mV.
- (3) Connect ground lead of DC VTVM to pin 8J on right channel of predriver/driver board. Connect probe of DC VTVM to pin 8Q on predriver/driver board.
- (4A) 250-T, 24R; Adjust pot. R816 for DC VTVM reading of 18 mV.
- (4B) 400-T; Adjust pot. R816 for DC VTVM reading of 15 mV.

### POWER OUTPUT MEASUREMENT

The output amplifier of this unit is designed to deliver its full-rated power with program material (voice or music) into 8-ohm loads for an indefinite period of time. When a constant audio tone is used as a signal to measure the maximum continuous RMS power output, the following precautions must be taken:

- (1) Measure the power output of one channel at a time.
- (2) Limit the measurement period to 10 minutes with a load resistance of 8 ohms.
- (3A) 250-T, 24R; Use a load resistor with a power rating of at least 50 watts.
- (3B) 400-T; Use a load resistor with a power rating of at least 100 watts.

**WARNING:** If the power output of both channels is measured simultaneously, use a load of 8 ohms per channel and limit measurements to a period not longer than 5 minutes.

**NOTE:** The 400-T uses a high temperature cutout switch to protect the amplifier against damage resulting from overheating. The switch disables the amplifier by eliminating drive signal in the audio control amplifier. When the amplifier cools to normal operating temperature, the cutout switch automatically resets.

### HARMONIC DISTORTION TEST

Set BALANCE, BASS, and TREBLE controls to their center positions. Set SELECTOR switch to AUX. Depress MAIN SPKRS pushbutton switch; release all other pushbutton switches to out position.

- (1) Connect an 8-ohm, 100-watt resistor across the LEFT SPEAKERS MAIN terminals. In parallel with the load resistor, connect the input leads of an HD analyzer and the input leads of an accurately calibrated AC VTVM.
- (2) Connect a low-distortion audio sine-wave generator, set for 1,000 Hz, to the LEFT channel AUX IN jack.

**NOTE:** Allow at least a 10 minute warm-up time before making measurements.

- (3) Rotate VOLUME control to maximum.
- (4A) 250-T, 24R; Increase audio generator level for 30 watts output (15.5 V RMS across 8-ohm load). HD meter should read 0.5% or less.
- (4B) 400-T; Increase audio generator level for 50 watts output (20.0 V RMS across 8-ohm load). HD meter should read 0.5% or less.
- (5) Repeat preceding steps for right channel.

### INTERMODULATION DISTORTION TEST

**NOTE:** Bypass C20 and C21 with direct connections for IM test on 24R console chassis. Bypass C17 and C18 on 25R.

Set BALANCE, BASS, and TREBLE controls to their center positions. Set SELECTOR switch to AUX. Depress MAIN SPKRS pushbutton switch; release all other pushbutton switches to out position.

- (1) Connect an 8-ohm, 100-watt resistor across the LEFT SPEAKERS MAIN terminals. In parallel with the load resistor, connect the input leads of an IM analyzer and the input leads of an accurately calibrated AC VTVM.
- (2) Connect IM-analyzer generator output to the LEFT channel AUX IN jack.

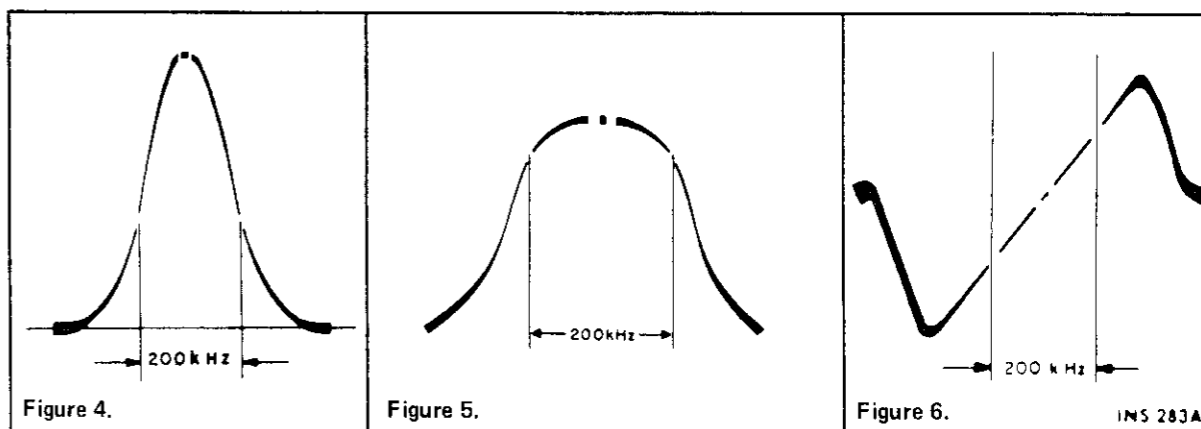

Figure 4.

Figure 5.

Figure 6.

INS 283A

**NOTE:** Allow set to warm up at least 10 minutes before making measurements.

- (3) Rotate VOLUME control to maximum.
- (4A) 250-T, 24R; Increase IM-analyzer generator output for 30 watts output (12.7 V RMS across 8-ohm load). IM meter reading should be 1.0% or less.
- (4B) 400-T; Increase IM-analyzer generator output for 50 watts output (16.4 V RMS across 8-ohm load). IM meter reading should be 1.0% or less.
- (5) Repeat preceding steps for right channel.

**NOTE:** If any of the preceding instructions differ from those in the IM-analyzer instruction manual, it is best to follow those in the manual. If a load resistor of 100-watt (or higher) rating is built into the IM analyzer, a separate load resistor is not required.

### FM IF AND DETECTOR ALIGNMENT

Set SELECTOR switch to FM, and AFC switch to OFF. Turn VOLUME control to minimum. Depress MUTING OFF pushbutton switch.

- (1) Disconnect the jumper lead from FM Test Point 301 (pin 3N on AM/FM IF, MPX board) and connect vertical AC input of scope to FM Test Point 301. Connect ground lead of scope to pin 3G.
- (2) Connect an 82k resistor across scope input and set scope vertical sensitivity to approximately 100mV/cm.
- (3) Connect 10.7 MHz sweep generator to Test Point 501 (pin 5J on FM RF board). Connect ground lead of generator to pin 5H. Adjust generator level and sweep to observe IF response curve.
- (4) Adjust top and bottom cores of Z305, Z304, and Z302 (on AM/FM IF, MPX board) for symmetry and maximum gain.
- (5) Adjust top and bottom cores of L505 (on FM RF board) for maximum gain and symmetry. Repeat alignment until maximum gain and symmetry are obtained (see Figure 4).
- (6) Increase generator level to full output (approximately 100,000  $\mu$ V). If necessary, slightly readjust top core of Z305 to center 10.7 MHz marker (see Figure 5).
- (7) Reconnect the jumper lead to FM Test Point 301 (pin 3N on AM/FM IF, MPX board) removed previously. Disconnect the 82k resistor across scope input connected previously.
- (8) Reduce generator sweep to zero (sweep off). Adjust FM METER ADJ. pot. R328 (on AM/FM IF, MPX board) for front panel tuning meter reading of 4.5.
- (9) Connect a 100k resistor in series with the vertical input of the scope and connect to FM Test Point 405 (pin 4A on AM/FM IF, MPX board). Use same AC scope sensitivity setting (100 mV/cm).
- (10) Adjust generator level and sweep to observe detector

### FM FRONT END ALIGNMENT

**NOTE:** FM IF alignment should be performed before starting this procedure.

Set SELECTOR switch to FM, and AFC switch to OFF. Turn VOLUME control to minimum. Depress MUTING OFF, and MONO MODE pushbutton switches. Depress MANUAL pushbutton on TUNE-O-MATIC dial assembly.

- (1) Set TUNING dial pointer to zero (0) calibration mark on the logging scale. If the dial pointer is not centered on the 0 at the extreme end of the knob rotation, reposition the pointer assembly on the dial cord and cement the pointer in place to prevent slippage. Allow cement to thoroughly dry.

**NOTE:** Repositioning the dial pointer may require realignment of AM RF board for correct AM station calibration.

- (2) Connect an accurately calibrated DC VTVM to Test Point 9B (on TUNE-O-MATIC circuit board). DO NOT USE DC VOM.
- (3) Rotate TUNING knob to center dial pointer on 88 MHz calibration mark on dial glass.
- (4) Using a small screwdriver, adjust R2B, FM ALIGNMENT POT. for DC VTVM reading of exactly 4.3 volts. Disconnect DC VTVM.
- (5) Connect an FM generator to the FM ANTenna terminals. Use a 120-ohm composition resistor in series with each lead from the generator (see Figure 7).
- (6) Connect a scope and an AC VTVM to either LEFT or RIGHT RC DR OUT jack.
- (7) Set FM generator frequency to receiver frequency, 90 MHz, modulated with 400 Hz,  $\pm 75$  kHz deviation. Set generator output level as low as possible.
- (8) Align (oscillator coil) L504 first, then (mixer coil) L503, and (RF coil) L502 for maximum reading on AC VTVM and tuning meter, and maximum waveform amplitude and symmetry.
- (9) Set generator frequency and TUNING dial pointer to 106 MHz. Align (oscillator trimmer) C512 first, then (mixer trimmer) C511, and (RF trimmer) C503 for maximum reading on AC VTVM and tuning meter, and maximum waveform amplitude and symmetry.
- (10) Repeat alignment several times until accurate dial calibration and maximum gain are obtained. Keep generator output level as low as possible during all adjustments.

## SERVICE PROCEDURES

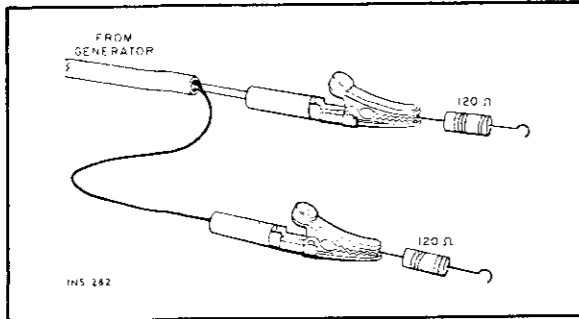

Figure 7. Connections To Provide 300-ohm Generator Output Impedance. Matching Resistors Reduce Generator Voltage By Half At Antenna Terminals.

### TUNING METER CALIBRATION

**NOTE:** If the FM IF AND DETECTOR ALIGNMENT procedure (including calibration of tuning meter) has been completed, omit the following procedure. Use the following procedure to calibrate the tuning meter without IF alignment; i.e., after meter replacement.

Set SELECTOR switch to FM. Turn VOLUME control to minimum.

- (1) Connect an FM generator to the FM ANTenna terminals. Use a 120-ohm composition resistor in series with each lead from the generator (see Figure 7).
- (2) Set generator frequency to same frequency as receiver. Set generator RF output level to full output (approximately 100,000  $\mu$ V) with audio modulation off.
- (3) Adjust generator frequency for peak tuning meter reading.
- (4) Adjust FM METER ADJ. pot. R328 (on AM/FM IF, MPX board) for tuning meter reading of 4.5.

### MULTIPLEX ALIGNMENT

Two methods of aligning the multiplex decoder are given. The preferred procedure uses a multiplex generator with RF and 19 kHz outputs and with 1 kHz modulation, such as the FISHER 300 Multiplex Generator. This is the better method of alignment because the front end and IF stages are also checked through the use of this procedure. An alternate procedure for use with multiplex generators not having an RF output is also given.

### PREFERRED ALIGNMENT PROCEDURE

**NOTE:** Check the alignment of the IF amplifier before aligning the multiplex decoder. Poor IF alignment can make proper MPX adjustment impossible.

- Set SELECTOR switch to FM. Turn VOLUME control to minimum. Depress MUTING OFF pushbutton switch. Depress MANUAL pushbutton on TUNE-O-MATIC dial assembly.
- (1) Connect RF output of multiplex generator to the FM ANTenna terminals. Use a 120-ohm composition resistor in series with each lead from the RF output (see Figure 7). Set MPX generator for external modulation with 19 kHz pilot carrier,  $\pm 7.5$  kHz deviation (10% pilot, no audio). Tune receiver to RF frequency of MPX generator.
  - (2) Connect DC VTVM to Test Point 403 (pin 4G on AM/FM IF, MPX board).
  - (3) Adjust cores of Z401 and Z402 (on AM/FM IF, MPX board) for maximum reading on DC VTVM (2.5 to 4 VDC).

- (4) Connect output of audio generator, set for 1 kHz, to the external modulation input of MPX generator and to external sync input of an oscilloscope. Adjust audio generator level for composite signal  $\pm 75$  kHz deviation (10% pilot, 90% audio). Modulate right channel only.
  - (5) Connect AC VTVM to LEFT RCDR OUT jack. Connect scope through voltage divider probe (see Figure 8) to Test Point 402 (pin 4K on AM/FM IF, MPX board).
  - (6) Turn R107 SEPARATION CONTROL (on preamplifier board) CW to maximum resistance setting. Adjust core of Z403 (on AM/FM IF, MPX board) for maximum gain and as straight a base-line as possible on scope (see Figure 9). AC VTVM should read minimum.
  - (7) With MPX generator modulated on right channel only, connect AC VTVM to RIGHT RCDR OUT jack. Record reading on AC VTVM.
  - (8) Set MPX generator to modulate left channel only. Adjust R107 SEPARATION CONTROL (on preamplifier board) for minimum reading on AC VTVM; at least 30 dB below reading recorded in step (7). Record reading.
  - (9) Connect AC VTVM to LEFT RCDR OUT jack. Same reading  $\pm 2$  dB as recorded in step (7).
  - (10) Set MPX generator to modulate right channel only. Same reading  $\pm 3$  dB as recorded in step (8).
- NOTE:** If equal readings cannot be obtained in steps (8) and (10), readjust Z402 slightly (on AM/FM IF, MPX board) and repeat steps (7) through (10).

### ALTERNATE ALIGNMENT PROCEDURE

Set SELECTOR switch to FM, and VOLUME control to minimum. Release all pushbutton switches to out position.

- (1) Disconnect the jumper lead going to pin 4A (on AM/FM IF, MPX board) and connect the output of the multiplex generator through a 15k resistor to pin 4A.
- (2) Connect DC VTVM to Test Point 403 (on AM/FM IF, MPX board). Connect the vertical input of the scope to pin 4A.
- (3) Set MPX generator for 19 kHz pilot carrier output only. Adjust pilot level for approximately 120 mV peak-to-peak input at pin 4A.
- (4) Adjust cores of Z401 and Z402 (on AM/FM IF, MPX board) for maximum reading on DC VTVM (2.5 to 4 VDC).
- (5) Connect output of audio generator, set for 1 kHz, to the external modulation input of MPX generator and to the external sync input of an oscilloscope. Adjust audio generator level for 1.2 volts peak-to-peak composite MPX input (10% pilot, 90% audio). See Figure 10. Modulate right channel only. Proceed with steps (5) through (10) of PREFERRED ALIGNMENT PROCEDURE.
- (6) Reconnect the jumper lead going to pin 4A (on AM/FM IF, MPX board) removed previously.

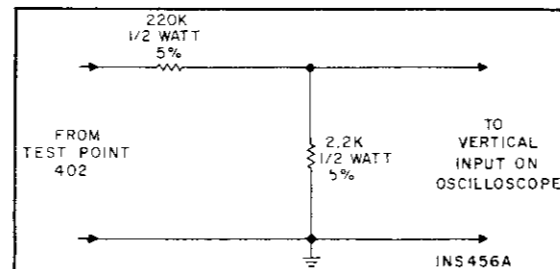

Figure 8. Voltage Divider Probe.

### AM IF ALIGNMENT

Set SELECTOR switch to AM, and VOLUME control to minimum.

- (1) Connect 455 kHz sweep generator to pin 7A (on AM RF board). Use a 0.1  $\mu$ F capacitor in series with the generator lead. Connect generator ground to pin 7C.

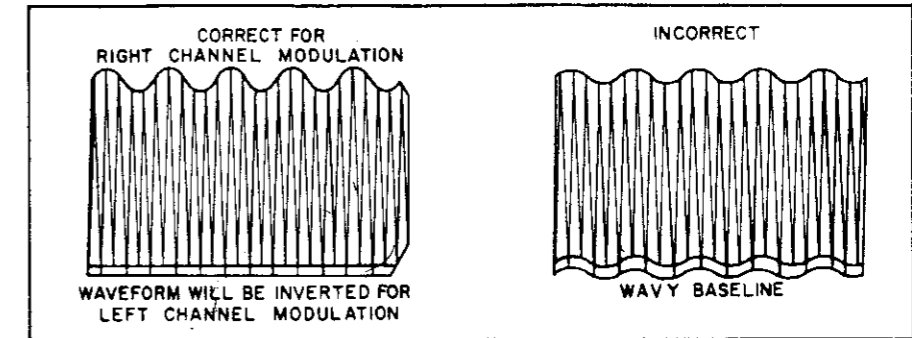

Figure 9. Waveform At Test Point 402.

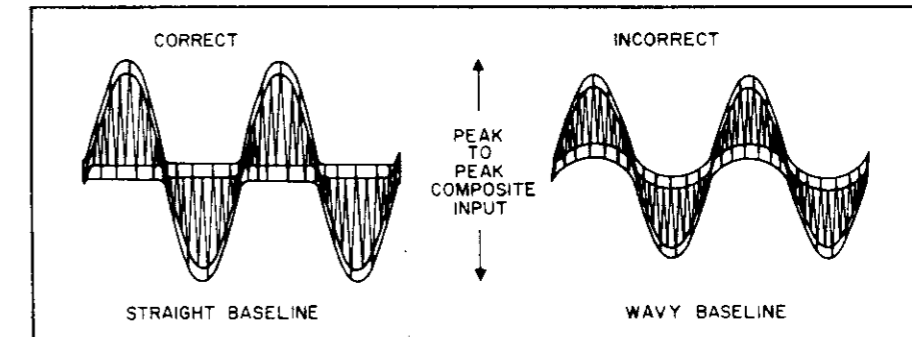

Figure 10. Composite Input To Multiplex Decoder.

- (2) Connect vertical input of scope to Test Point 302 (pin 3Q on AM/FM IF, MPX board). Connect scope ground to pin 3G. Set scope vertical input sensitivity to approximately 200 mV/cm.
- (3) Adjust generator level and sweep to observe IF response curve. Set generator output as low as possible.
- (4) Adjust top and bottom cores of Z303, Z301 (on AM/FM IF, MPX board), and Z702 (on AM RF board) for maximum gain and symmetry. Repeat alignment until maximum gain and symmetry are obtained (see Figure 11).

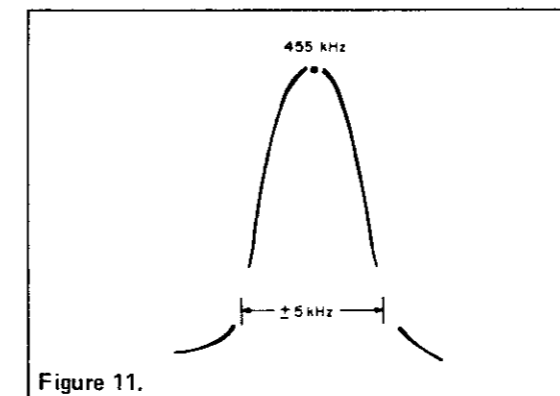

Figure 11.

### AM RF ALIGNMENT

**NOTE:** AM IF alignment should be performed before starting this procedure.

- Set SELECTOR switch to AM and VOLUME control to minimum.
- (1) Set TUNING dial pointer to zero (0) calibration mark on the logging scale. If dial pointer does not coincide with the 0 at the extreme end of knob rotation, reposition the pointer assembly on the dial cord and cement the pointer in place to prevent slippage. Allow cement to thoroughly dry.

- NOTE:** Repositioning the dial pointer may require realignment of FM RF board for correct FM station calibration.
- (2) Open the AM ANTenna GND link at the antenna terminals. Connect an AM generator to the AM ANTenna and GND terminals.
  - (3) Connect a scope and an AC VTVM to either the LEFT or RIGHT RCDR OUT jack.
  - (4) Set AM generator frequency and TUNING dial pointer to 600 kHz. Use 30% modulation with 400 Hz. Set generator output as low as possible.
  - (5) Align oscillator coil Z701 (on AM RF board) for maximum reading on AC VTVM and maximum waveform amplitude and symmetry.
  - (6) Set AM generator frequency and TUNING dial pointer to 1400 kHz. Adjust oscillator trimmer C703 (on AM RF board) for maximum reading on AC VTVM and maximum waveform amplitude and symmetry.
  - (7) Repeat alignment several times until accurate dial calibration and maximum gain are obtained. Keep the generator output as low as possible during all adjustments.
  - (8) Reset AM generator frequency and TUNING dial pointer to 600 kHz. Adjust the position of the small coil on the ferrite loop antenna for maximum reading on AC VTVM and maximum waveform amplitude and symmetry.

**NOTE:** To adjust the antenna coil, melt the wax holding the small coil to the end of the ferrite loop antenna. Shift the coil back and forth for maximum audio indication. To secure the coil in position, remelt the wax.

- (9) Reset AM generator frequency and TUNING dial pointer to 1400 kHz. Adjust antenna trimmer C701 (on AM RF board) for maximum reading on AC VTVM and maximum waveform amplitude and symmetry.
- (10) Repeat steps (8) and (9) several times until maximum gain is obtained. Keep generator output as low as possible during all adjustments.
- (11) Test for peak alignment by setting AM generator and TUNING dial pointer to 600 kHz. Adjust generator RF output level for tuning meter reading of 3. Generator RF output level should read between 500  $\mu$ V and 1600  $\mu$ V.
- (12) Set AM generator and TUNING dial pointer to 1400 kHz. Adjust generator RF output level for tuning meter reading of 3. Generator RF output level should read between 150  $\mu$ V and 500  $\mu$ V.

1535-1 FM RF

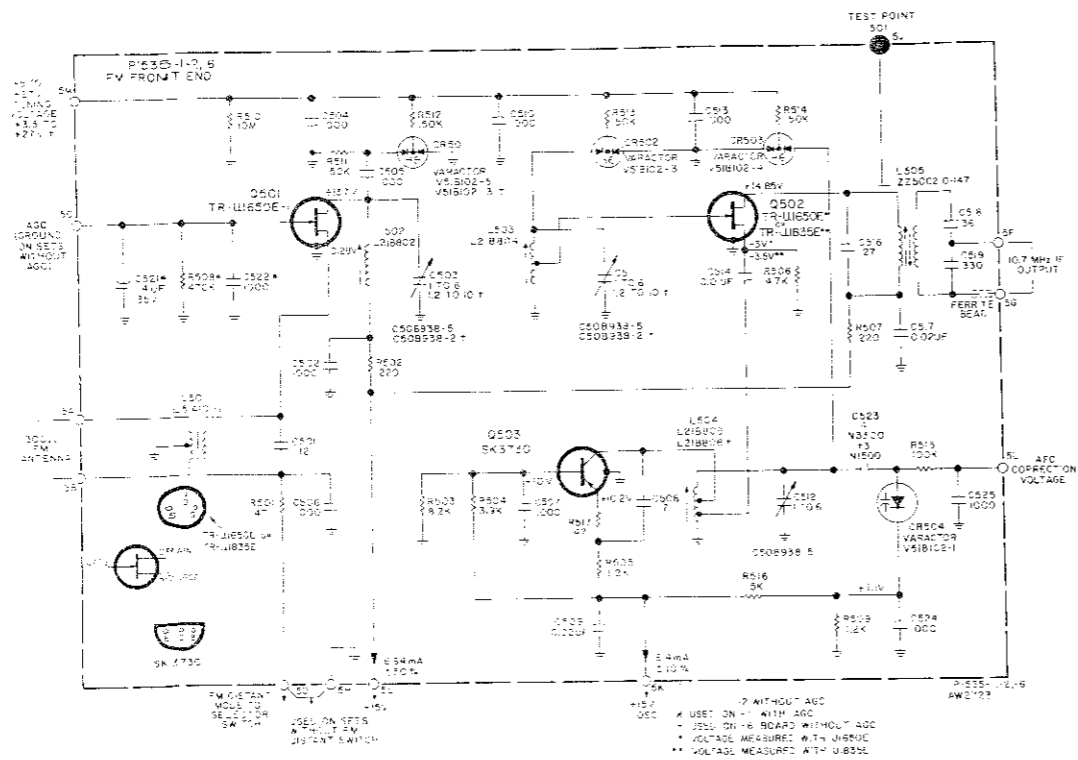

BOARD VIEWED FROM COMPONENT SIDE

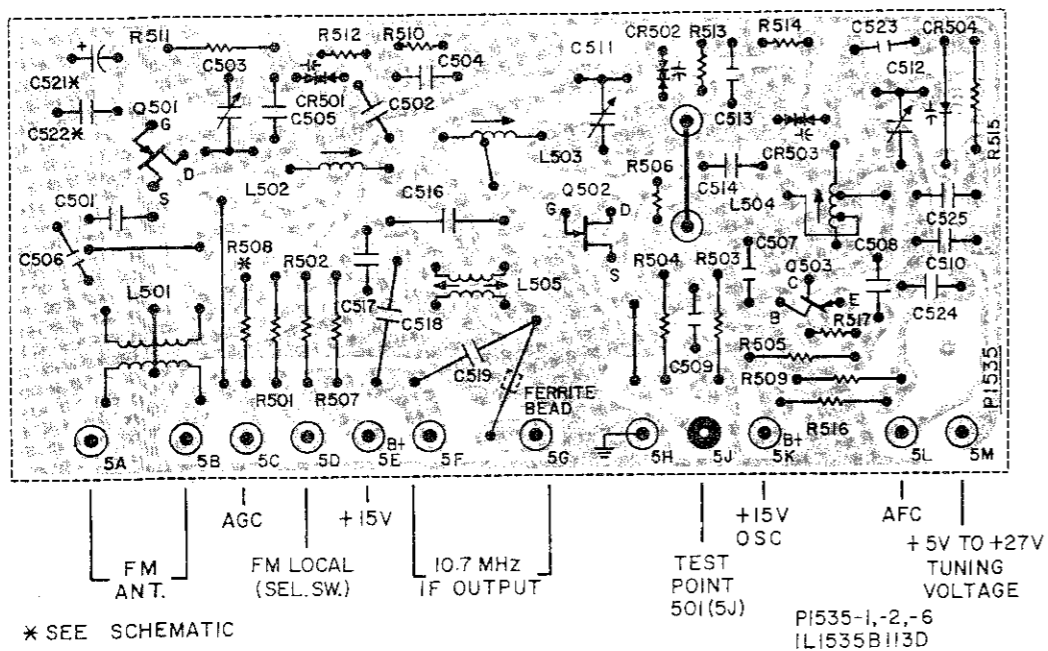

2026-3 AM RF

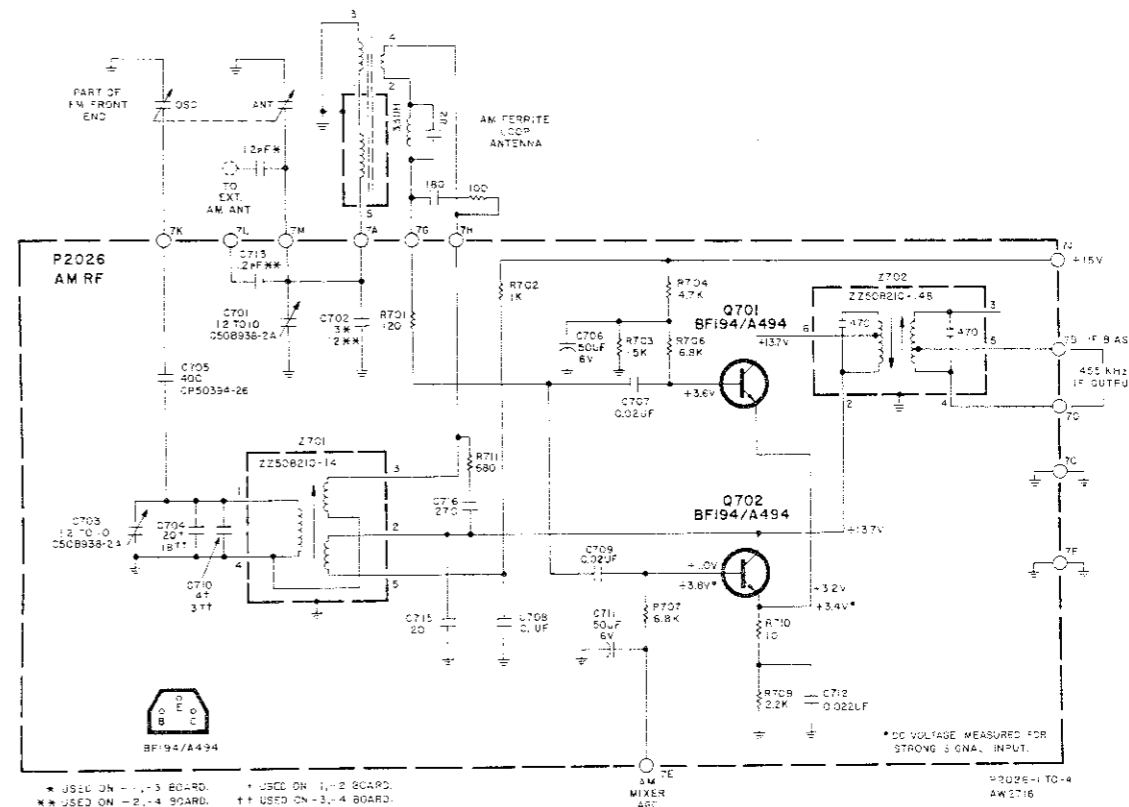

BOARD VIEWED FROM COMPONENT SIDE

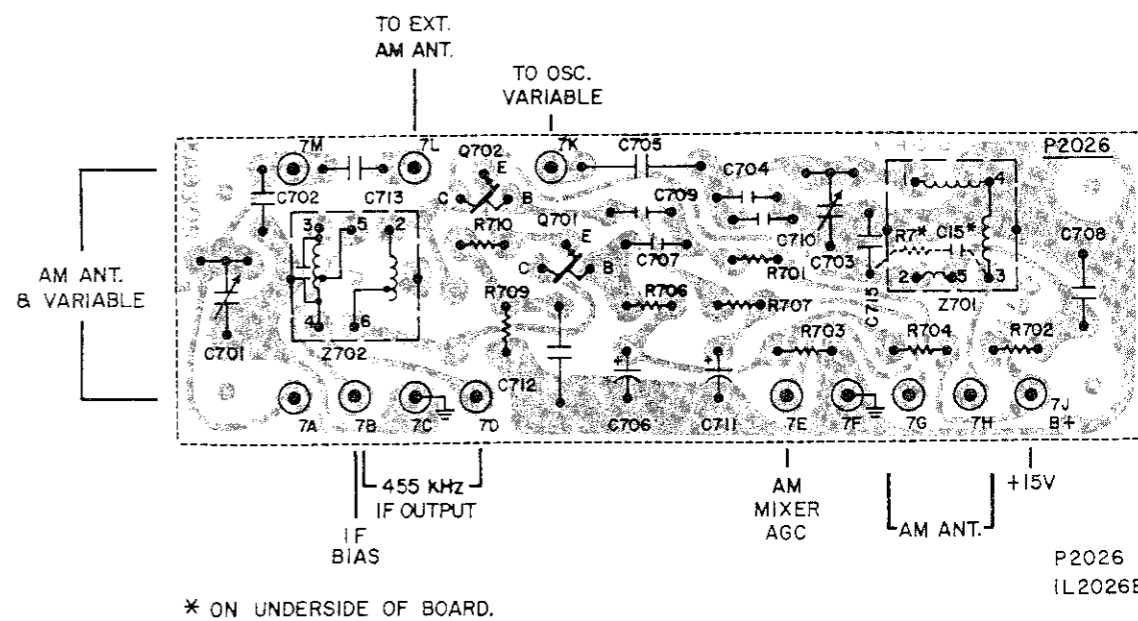

(400-T) CHASSIS LAYOUT

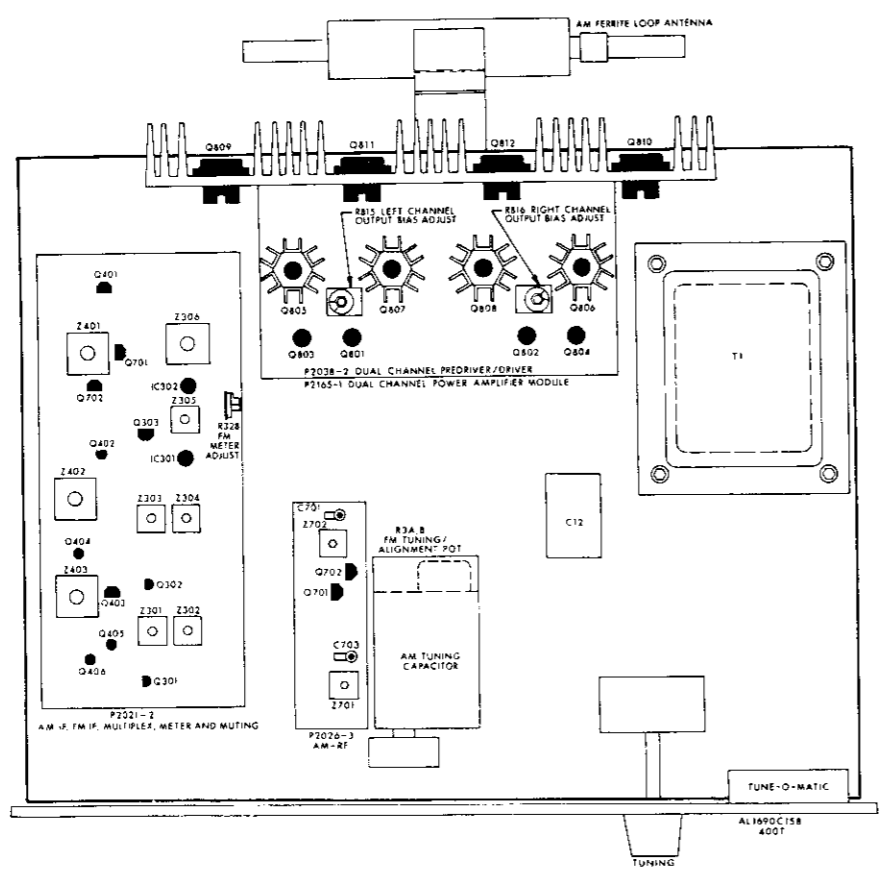

TOP

(250-T) CHASSIS LAYOUT

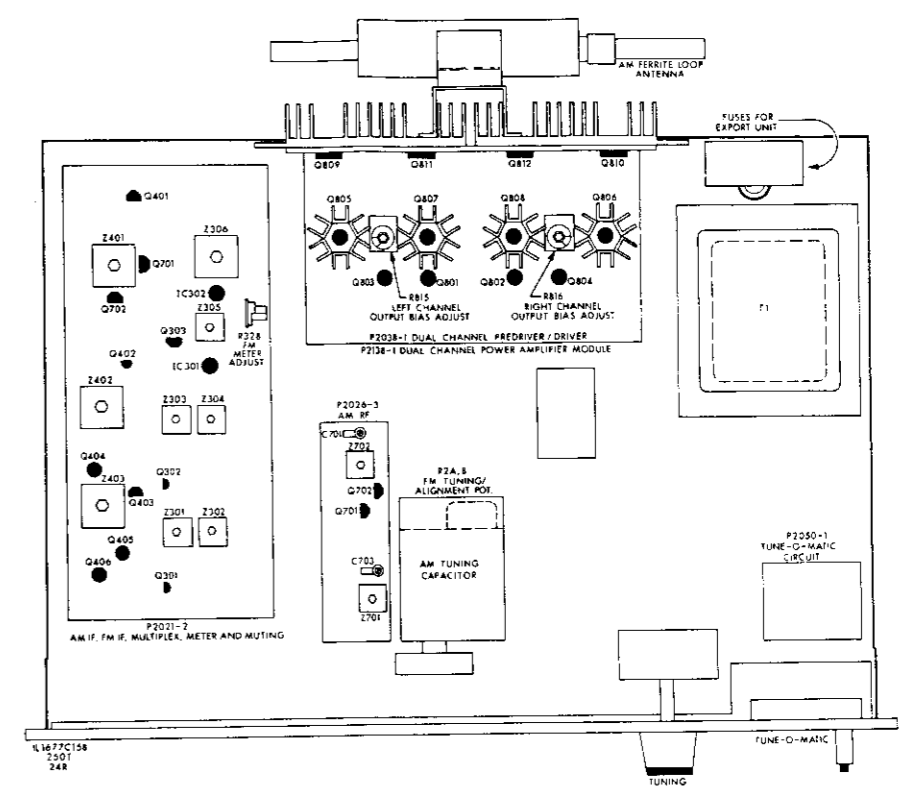

TOP

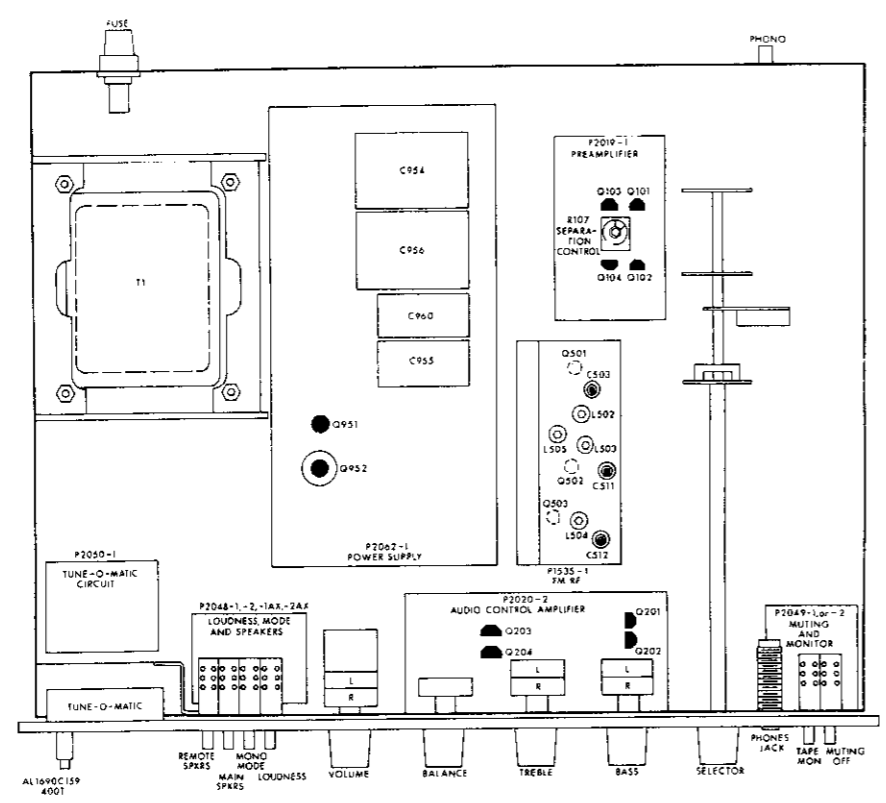

BOTTOM

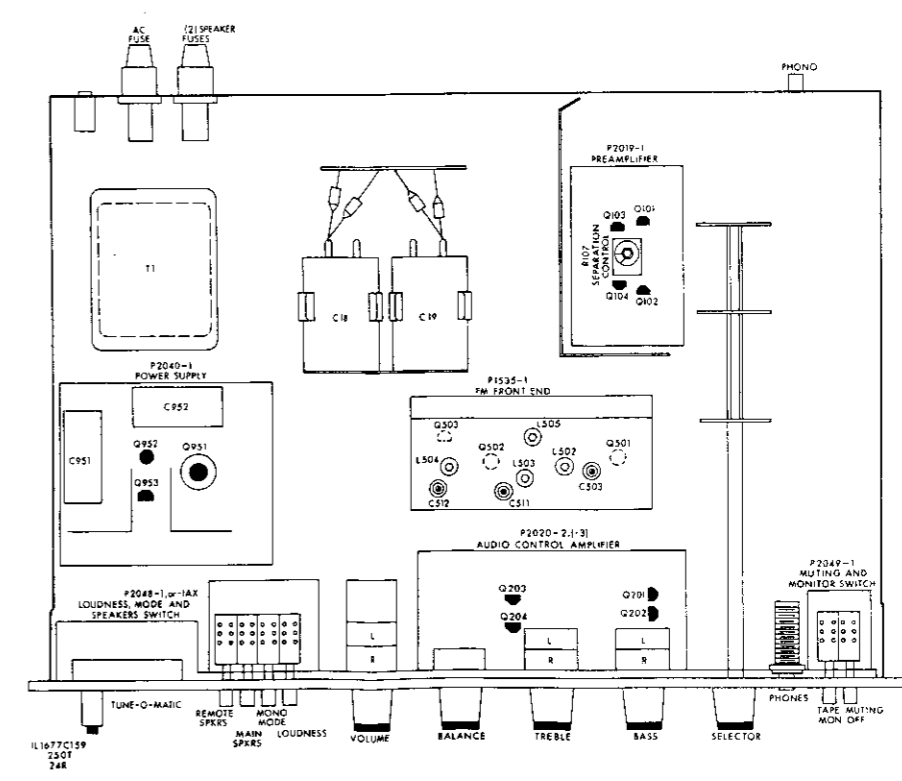

BOTTOM

# 2021-2 AM-FM IF, MPX, METER, MUTING

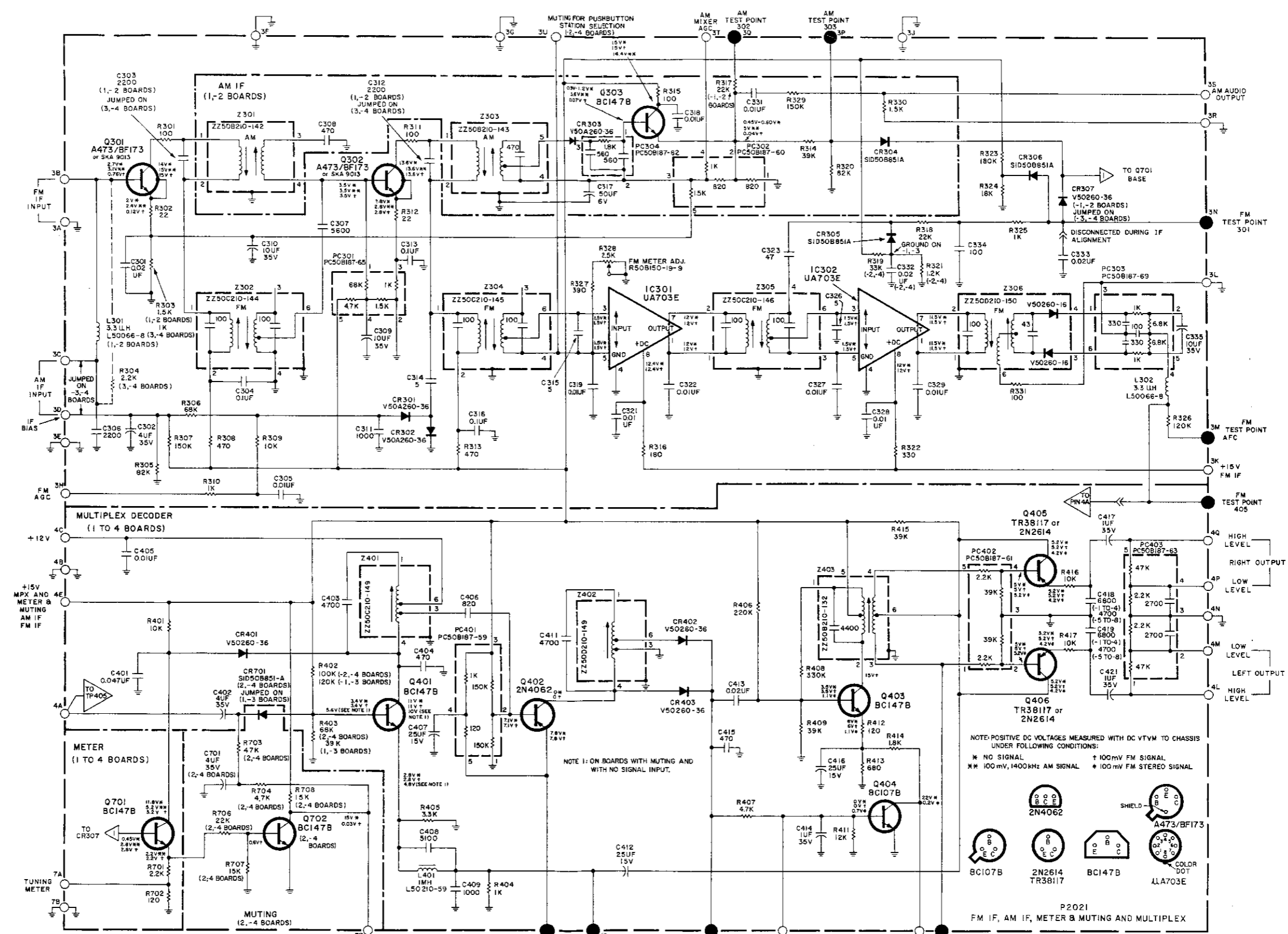

-1 (-5) BOARD (AM IF, FM IF, MPX, AND METER)  
 -2 (-6) BOARD (AM IF, FM IF, MPX AND METER & MUTING)  
 -3 (-7) BOARD (FM IF, MPX, AND METER)  
 -4 (-8) BOARD (FM IF, MPX AND METER & MUTING)

TO MUTING SWITCH (2,-4 BOARDS)  
 MPX TEST POINT 404  
 MPX TEST POINT 401  
 MPX TEST POINT 403  
 STEREO DEFEAT  
 TO STEREO BEACON  
 MPX TEST POINT 402

P2021  
 FM IF, AM IF, METER & MUTING AND MULTIPLEX  
 P2021-1 TO -8  
 AW 2717

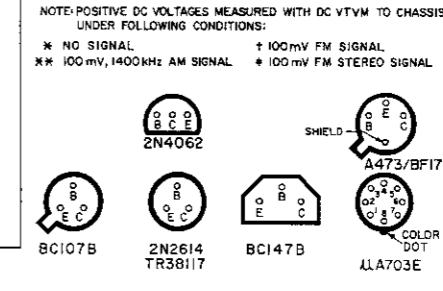



2021-2 AM-FM IF, MPX, METER, MUTING

BOARD VIEWED FROM COMPONENT SIDE

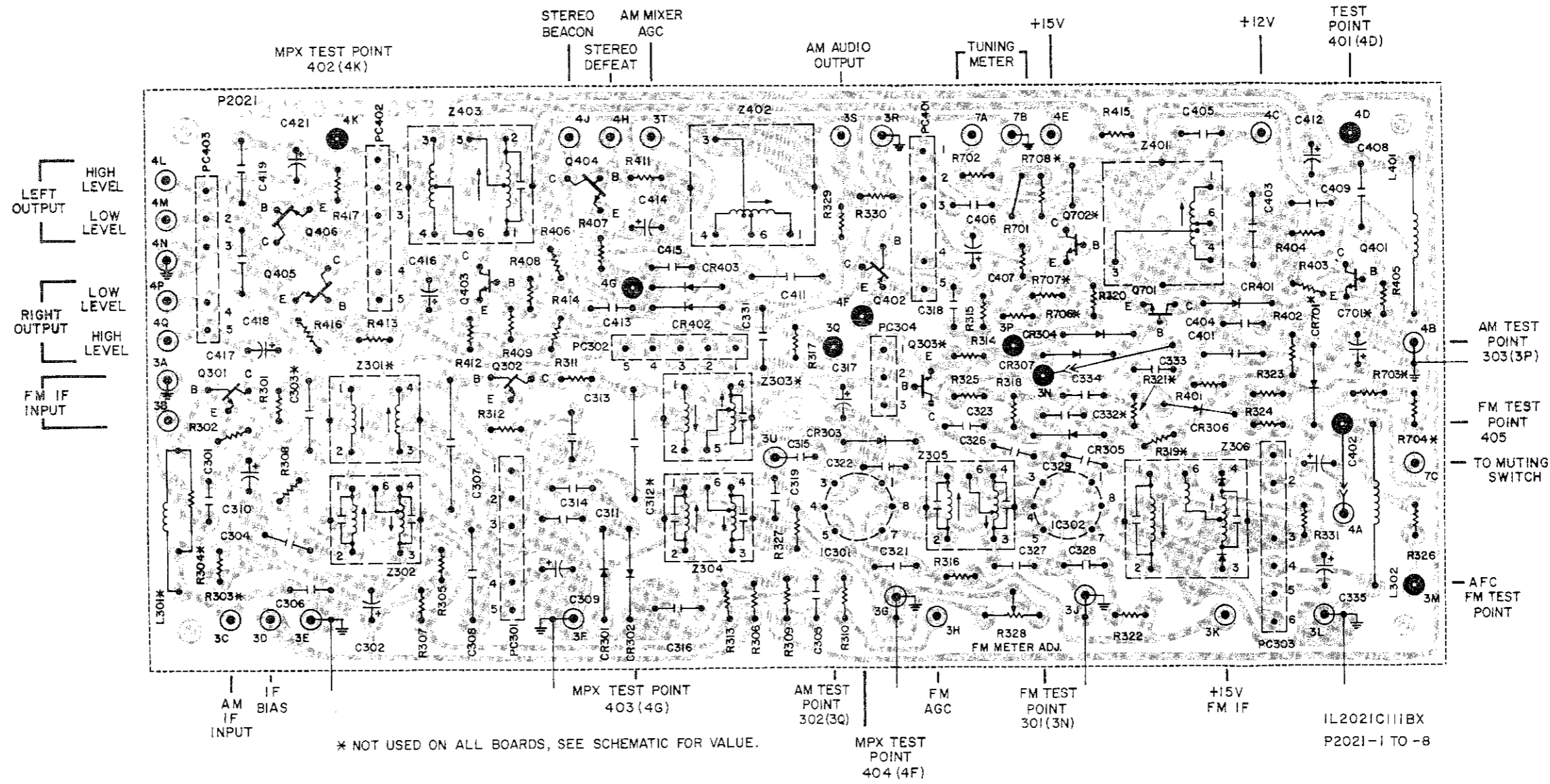

2049-1 MUTING, MONITOR

SCHEMATIC SHOWN ON MAIN CHASSIS DIAGRAM

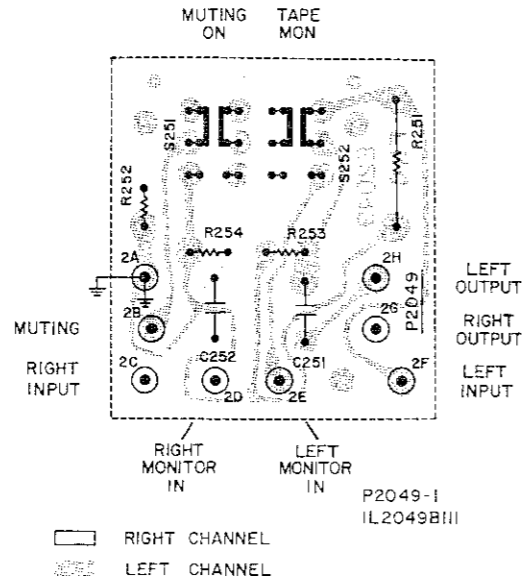

BOARD VIEWED FROM COMPONENT SIDE

2050-1 TUNE-O-MATIC

SCHEMATIC SHOWN ON MAIN CHASSIS DIAGRAM

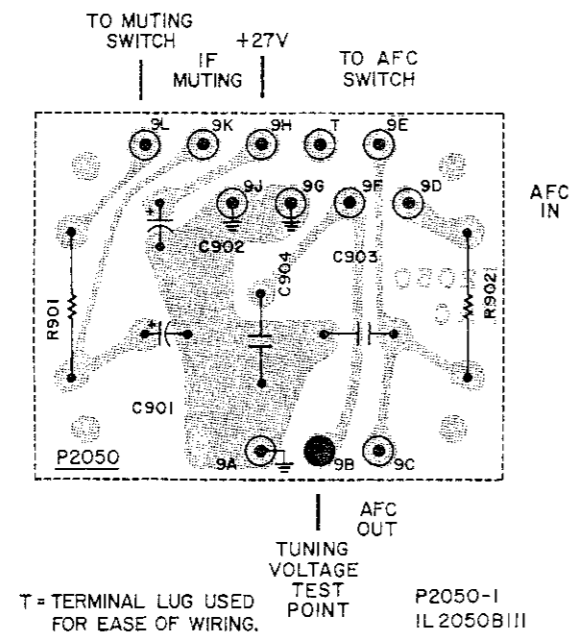

BOARD VIEWED FROM COMPONENT SIDE

2019-4 PREAMPLIFIER

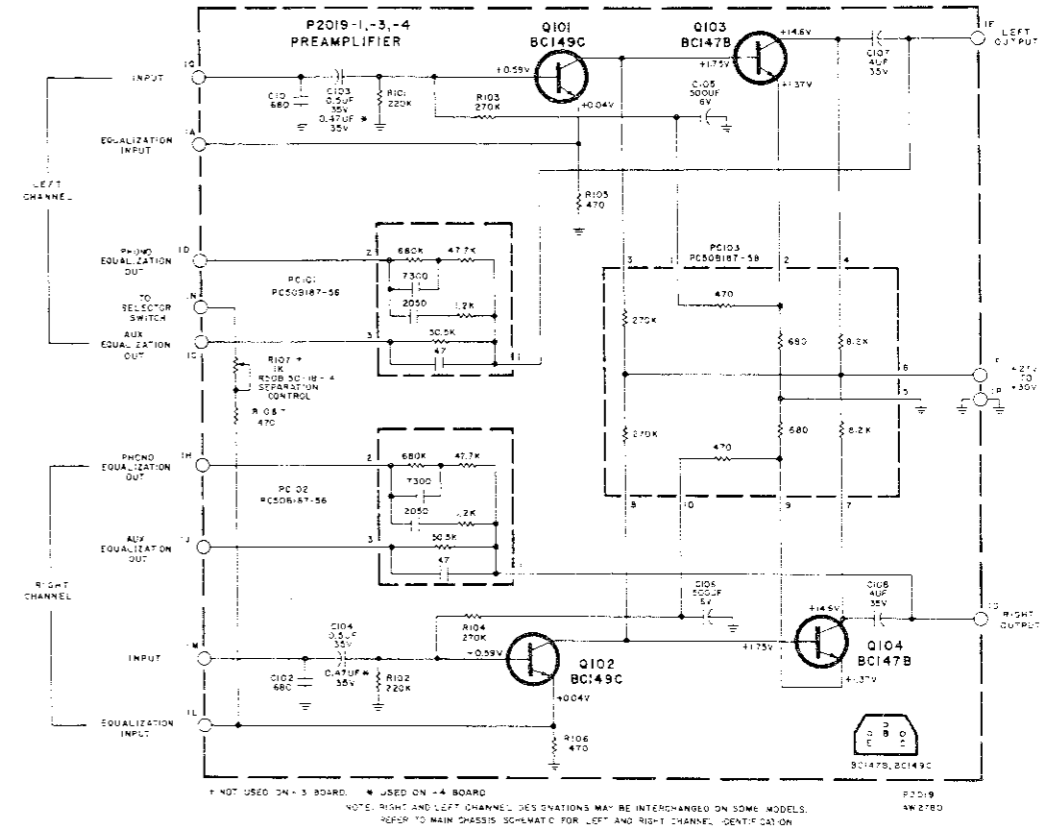

BOARD VIEWED FROM COMPONENT SIDE

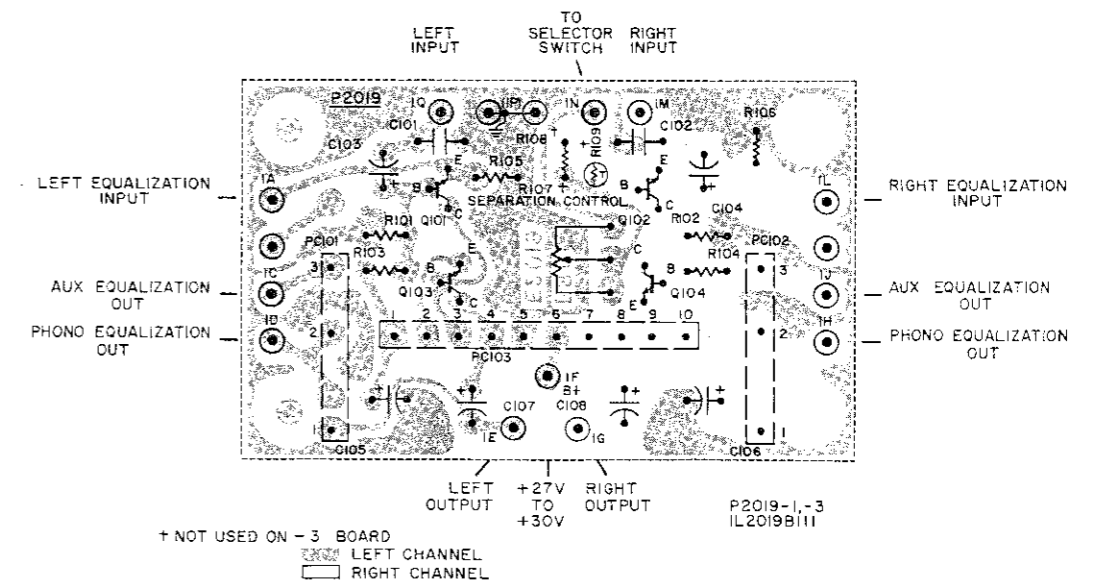

2020-2, -3, -4 AUDIO CONTROL AMPLIFIER

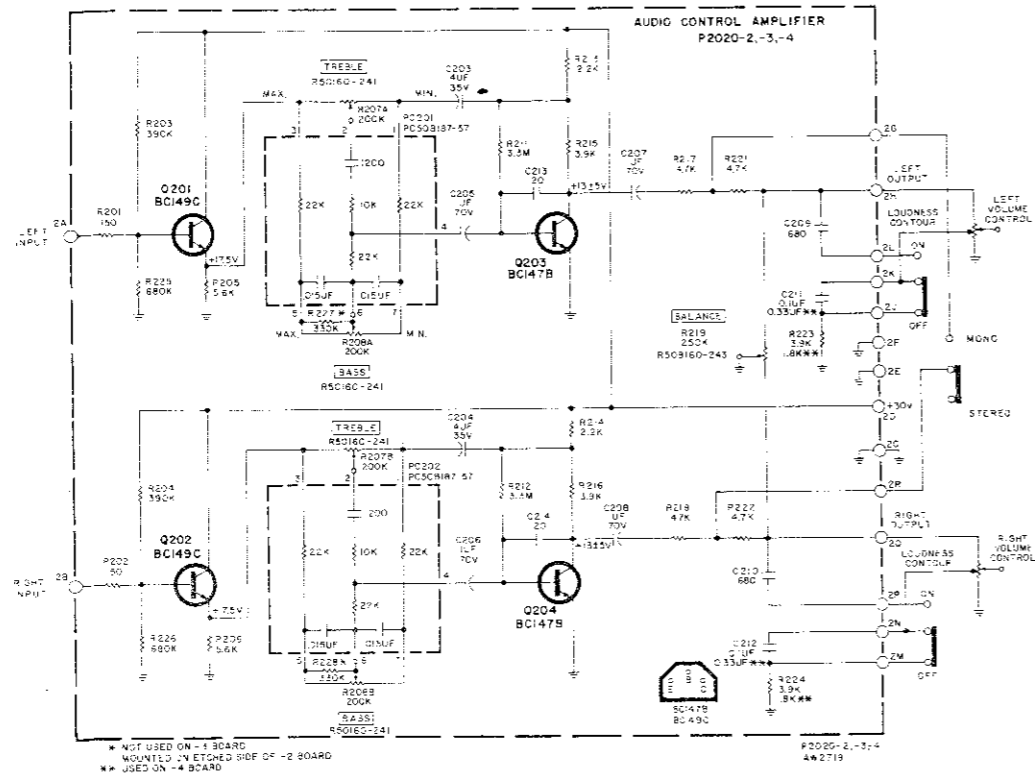

\* NOT USED ON -1 BOARD  
 MOUNTED IN ETCHED SIDE OF -2 BOARD  
 \*\* USED ON -4 BOARD

2048-1 LOUDNESS, MODE, SPEAKER

SCHEMATIC SHOWN ON MAIN CHASSIS DIAGRAM

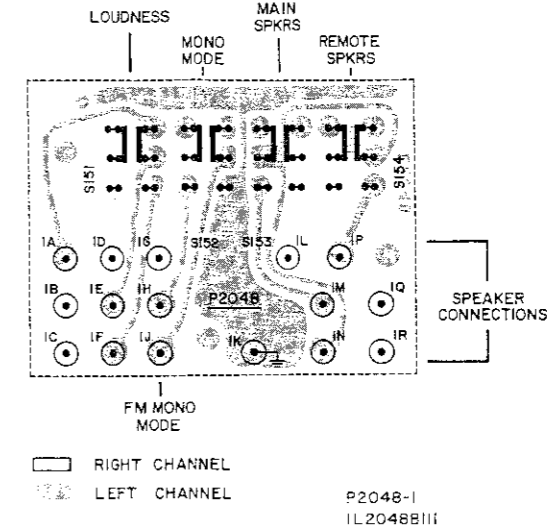

BOARD VIEWED FROM COMPONENT SIDE

2048-1AX LOUDNESS, MODE, SPEAKER

AX DESIGNATES REVISED BOARD

SCHEMATIC SHOWN ON MAIN CHASSIS DIAGRAM

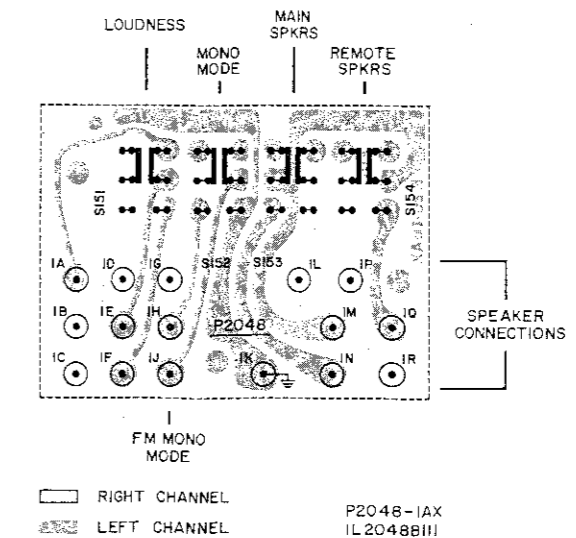

BOARD VIEWED FROM COMPONENT SIDE

BOARD VIEWED FROM COMPONENT SIDE

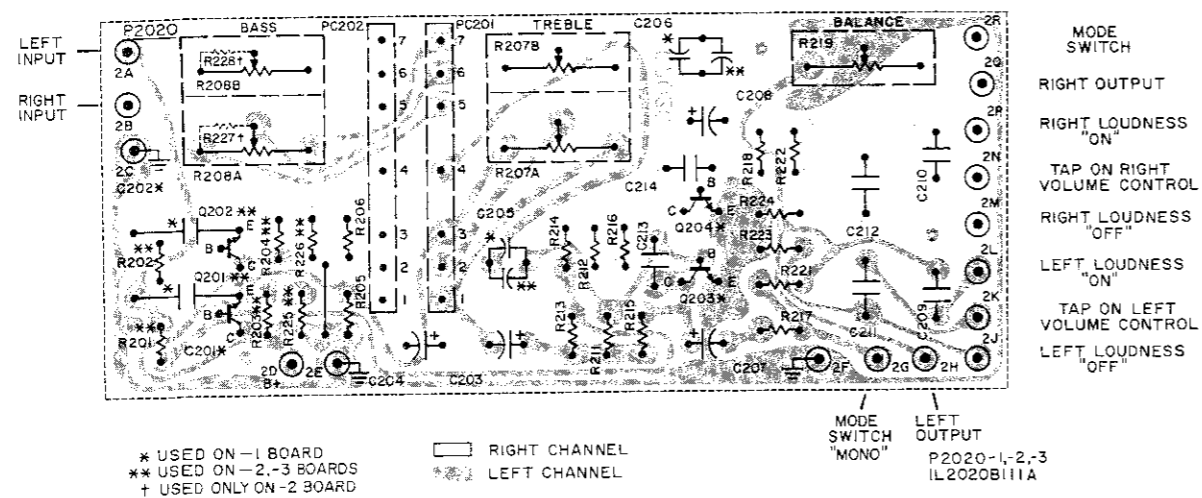

\* USED ON -1 BOARD  
 \*\* USED ON -2, -3 BOARDS  
 † USED ONLY ON -2 BOARD

□ RIGHT CHANNEL  
 ◻ LEFT CHANNEL

MODE SWITCH "MONO"  
 LEFT OUTPUT  
 P2020-1, -2, -3  
 IL2020B111A

2138-1 POWER AMPLIFIER MODULE (250-T)

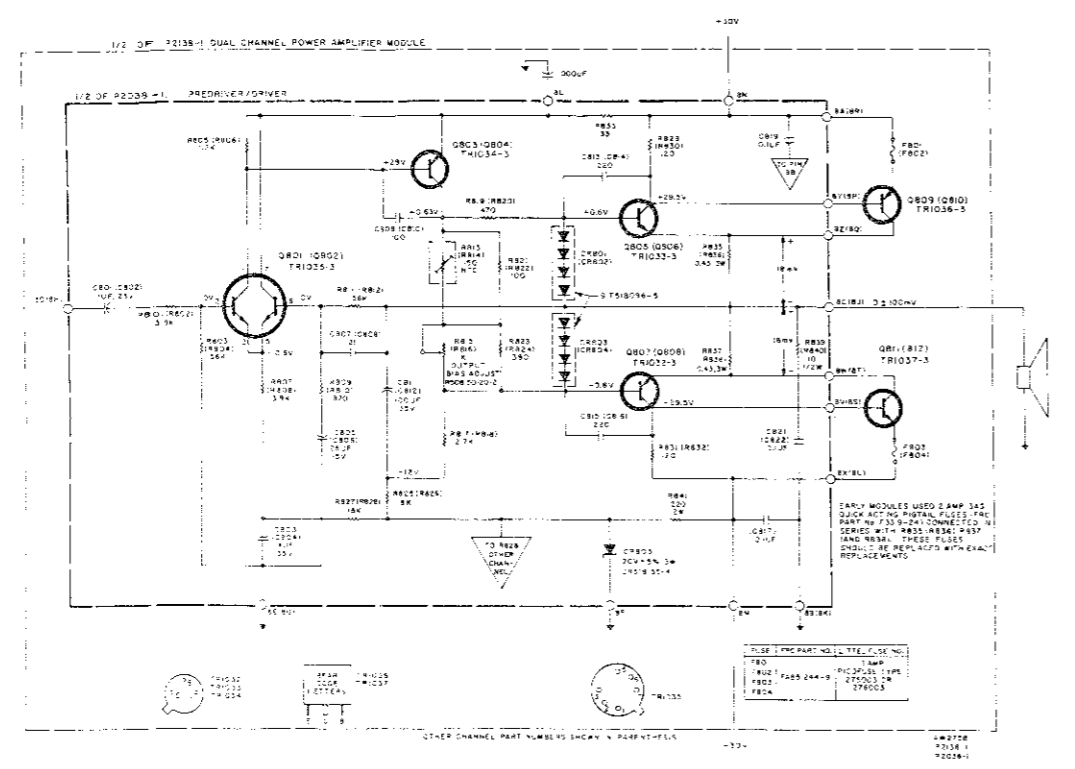

2165-1 POWER AMPLIFIER MODULE (400-T)

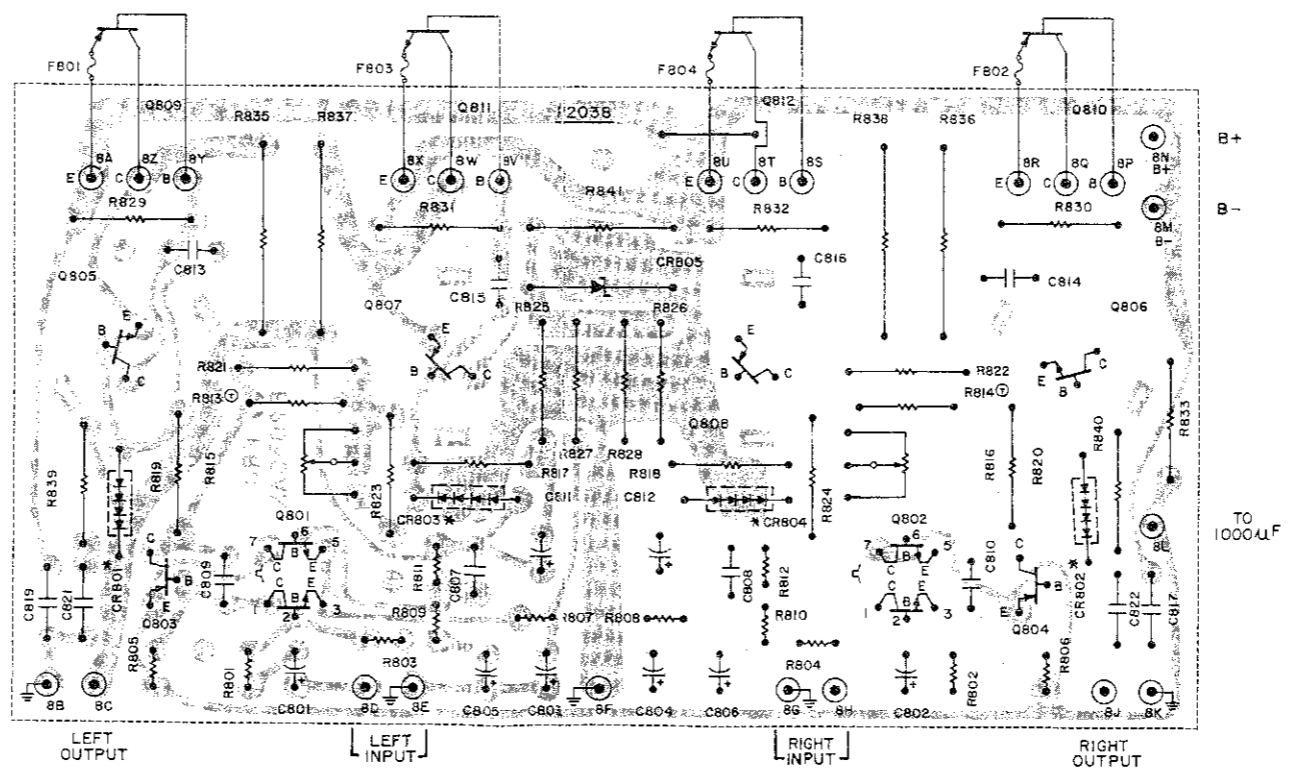
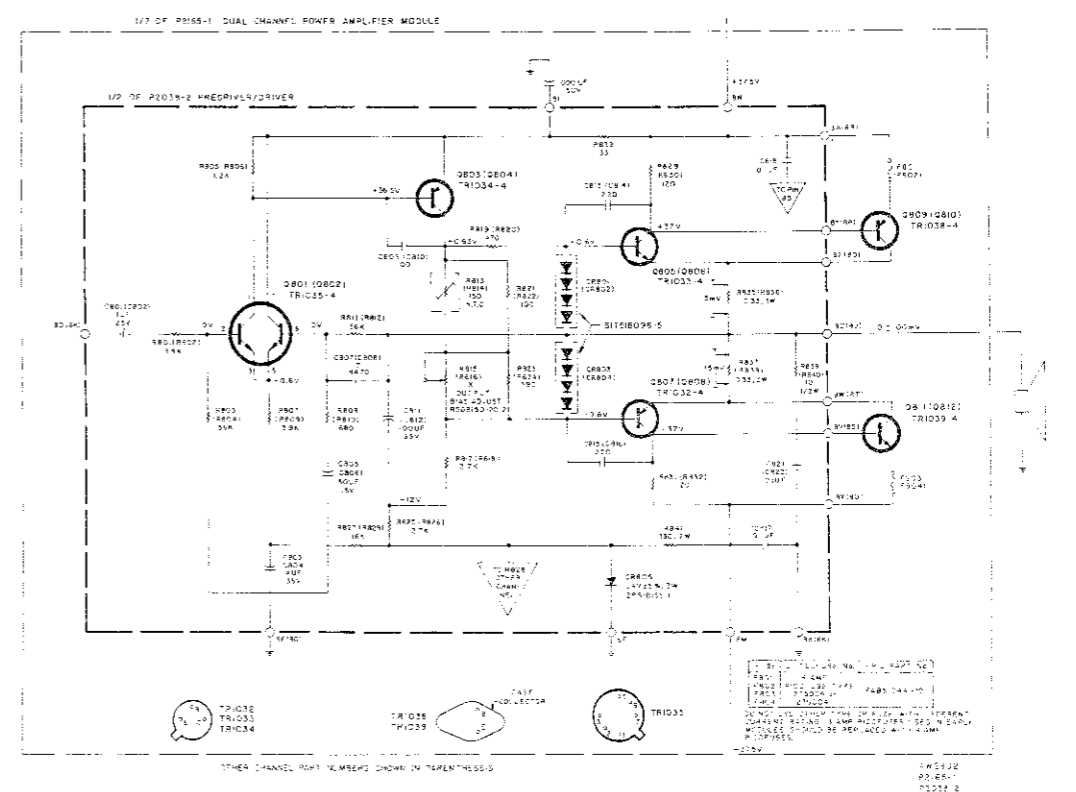

BOARD VIEWED FROM COMPONENT SIDE

P2038-1,-2,-3  
IL2038B111B

2062-1 POWER SUPPLY (400-T)

SCHEMATIC SHOWN ON MAIN CHASSIS DIAGRAM

BOARD VIEWED FROM COMPONENT SIDE

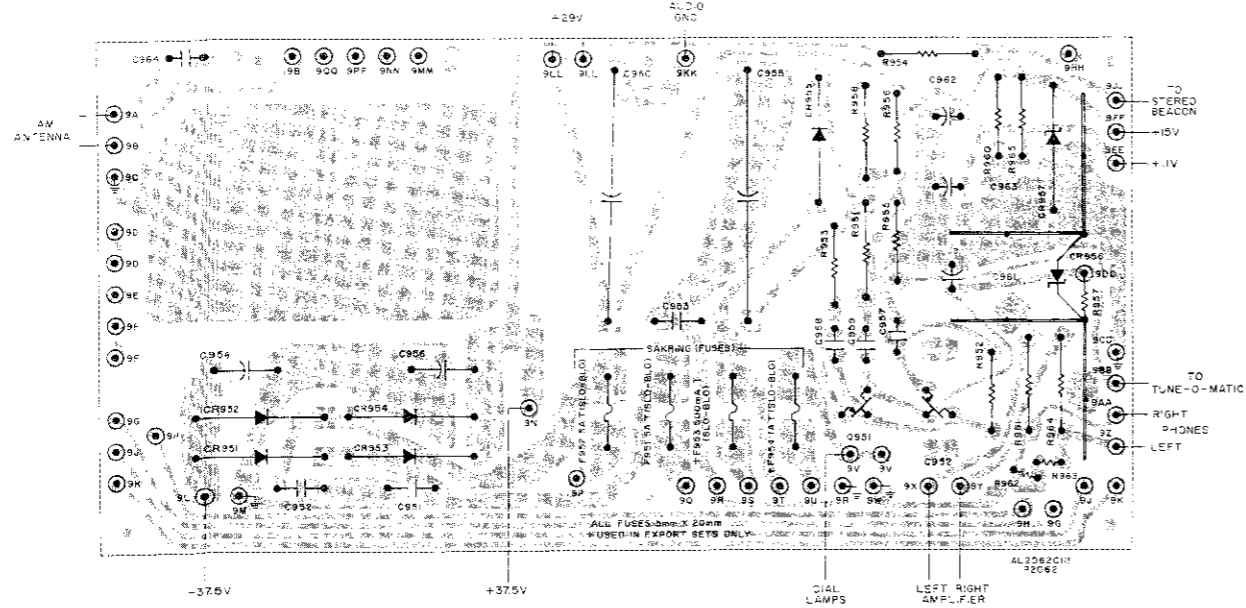

2040-1 POWER SUPPLY (250-T)

SCHEMATIC SHOWN ON MAIN CHASSIS DIAGRAM

BOARD VIEWED FROM COMPONENT SIDE

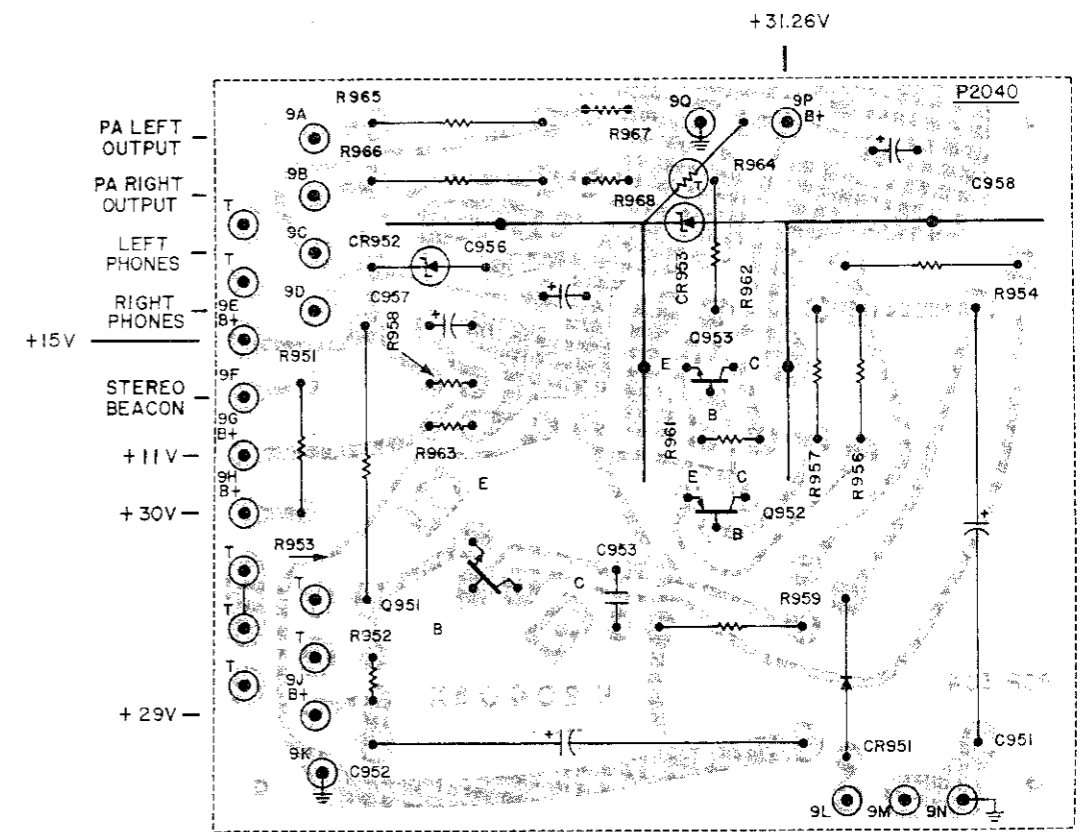

(250-T) MAIN CHASSIS - TUNER SECTION

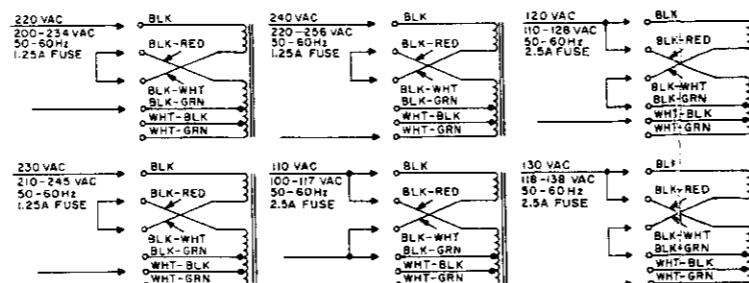

TU POWER TRANSFORMER STRAPPING

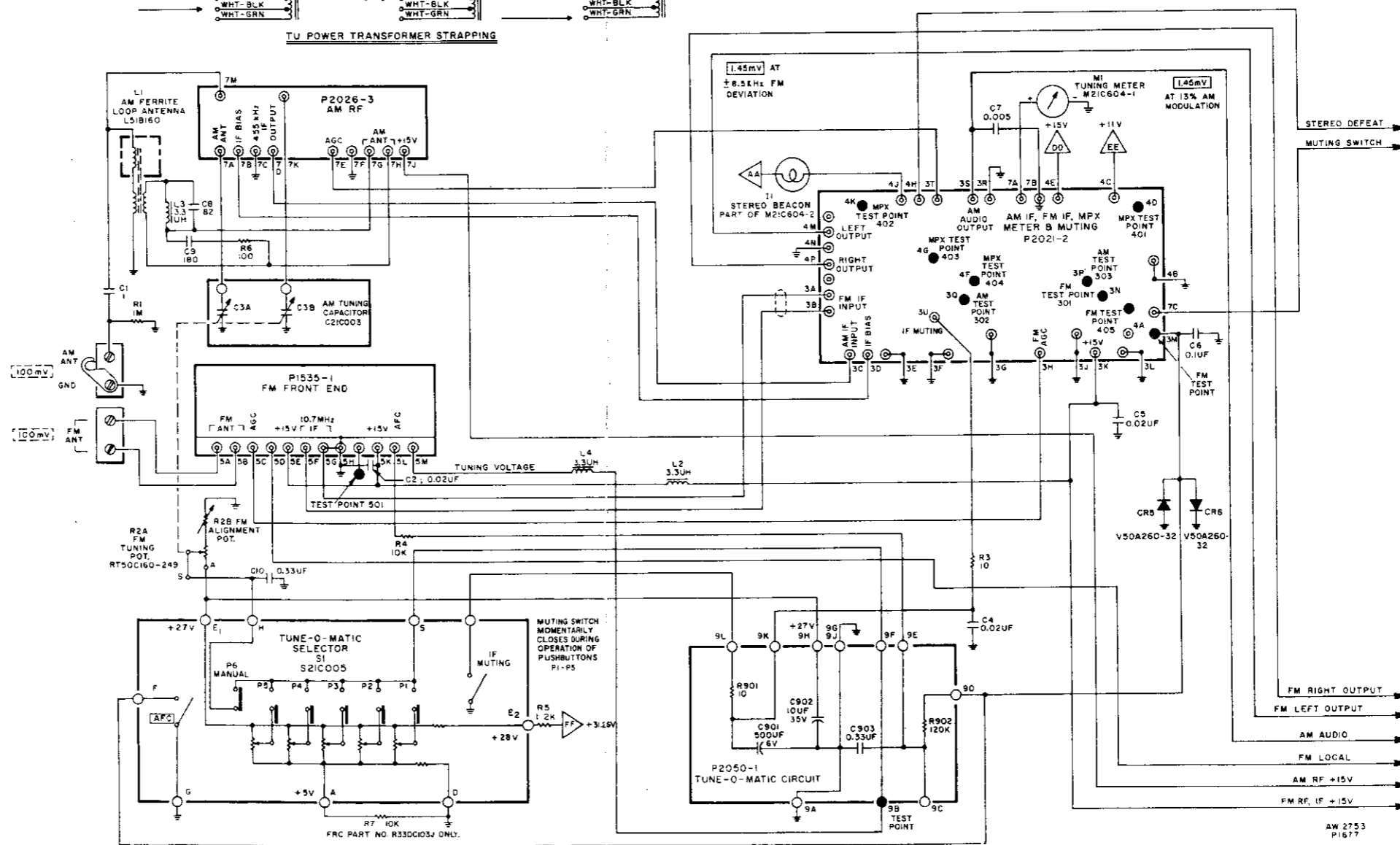

## (250-T) MAIN CHASSIS - AMPLIFIER SECTION

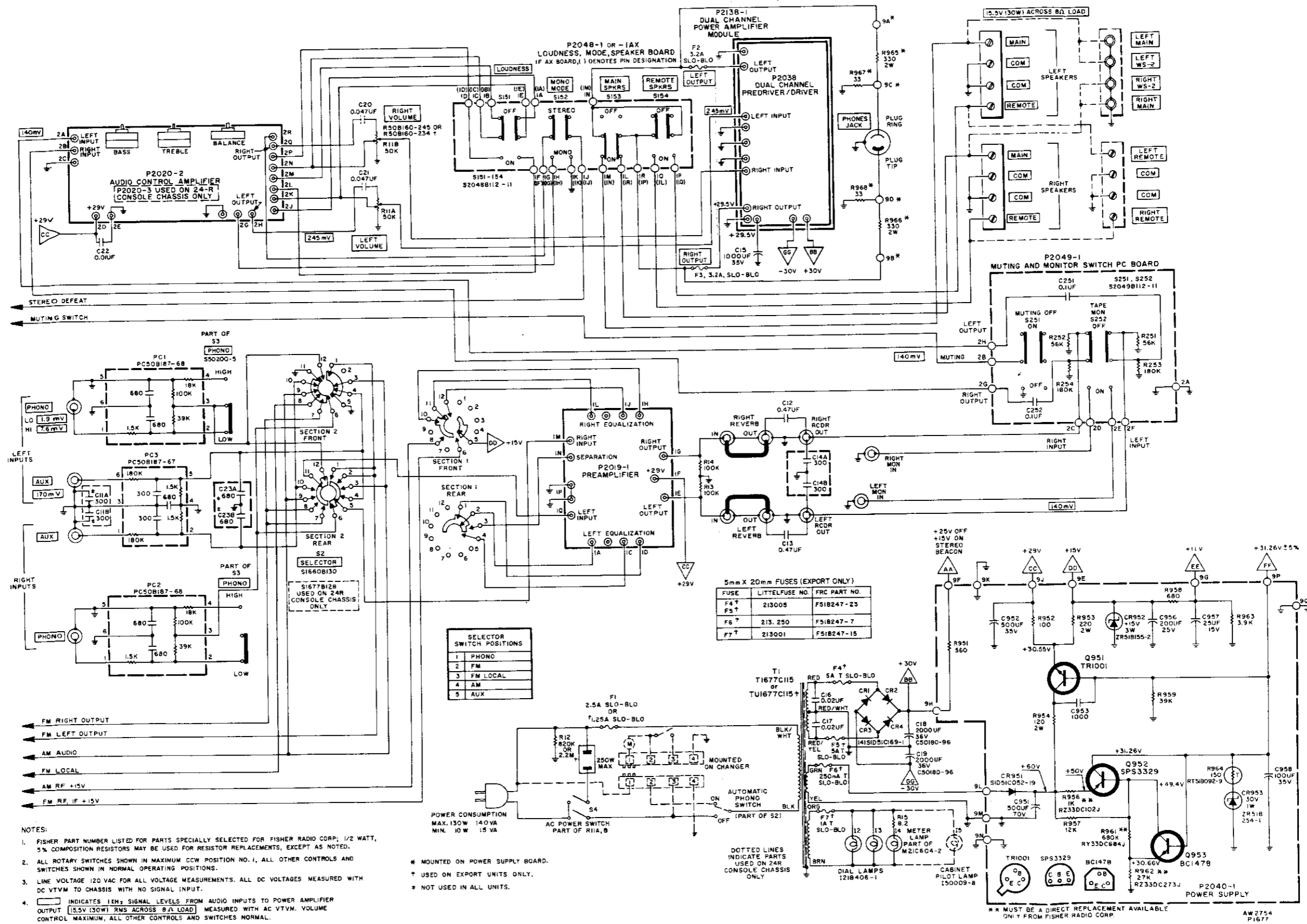

(400-T) MAIN CHASSIS – TUNER SECTION

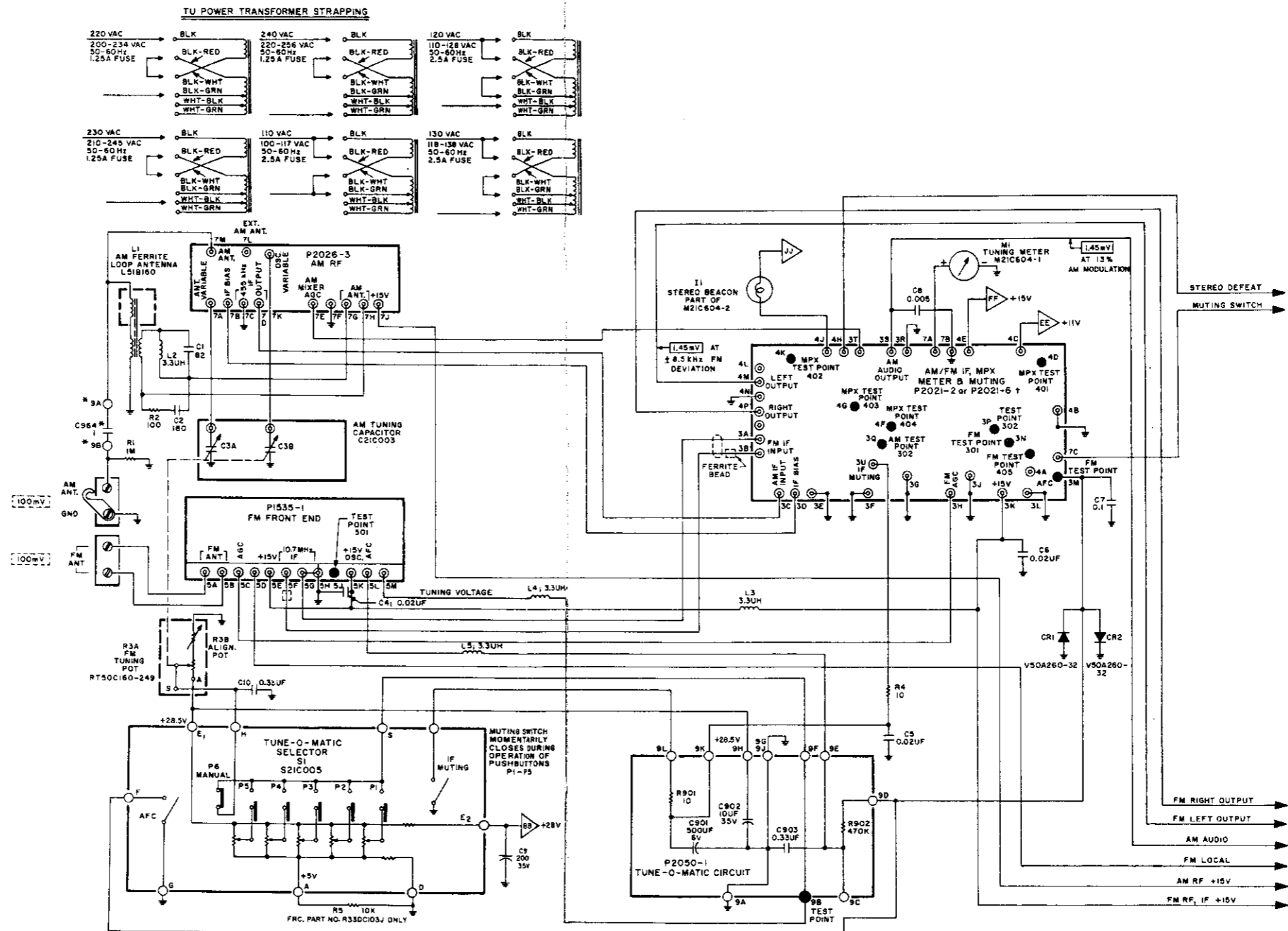

† USED ON EXPORT UNITS ONLY  
\* MOUNTED ON POWER SUPPLY BOARD



(400-T) MAIN CHASSIS - AMPLIFIER SECTION

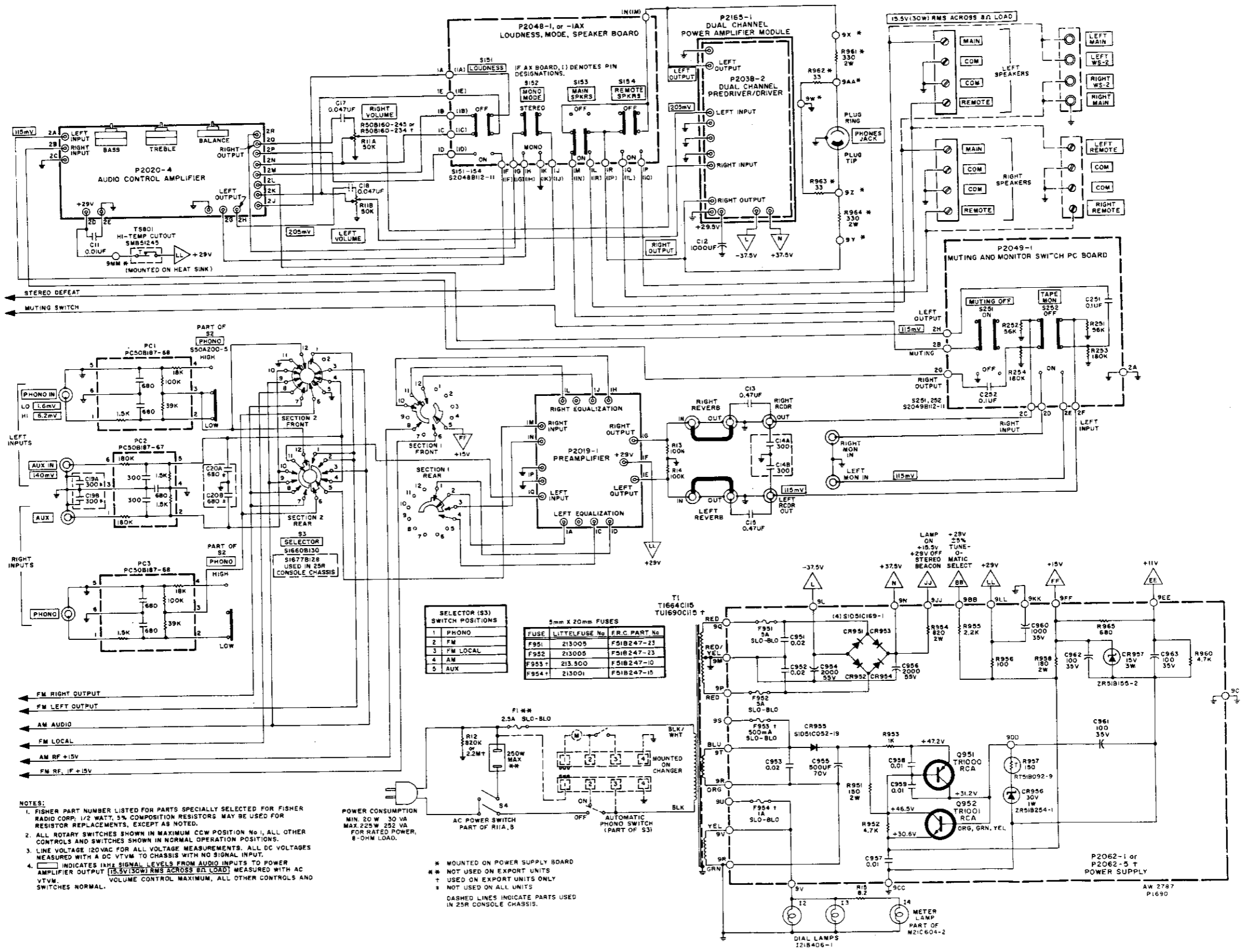

- NOTES:**
1. FISHER PART NUMBER LISTED FOR PARTS SPECIALLY SELECTED FOR FISHER RADIO CORP. 1/2 WATT, 5% COMPOSITION RESISTORS MAY BE USED FOR RESISTOR REPLACEMENTS, EXCEPT AS NOTED.
  2. ALL ROTARY SWITCHES SHOWN IN MAXIMUM CCW POSITION No. 1, ALL OTHER CONTROLS AND SWITCHES SHOWN IN NORMAL OPERATION POSITIONS.
  3. LINE VOLTAGE 120 VAC FOR ALL VOLTAGE MEASUREMENTS. ALL DC VOLTAGES MEASURED WITH A DC VTVM TO CHASSIS WITH NO SIGNAL INPUT.
  4. [Symbol] INDICATES IN Hz SIGNAL LEVELS FROM AUDIO INPUTS TO POWER AMPLIFIER OUTPUT [15.5V/30W RMS ACROSS 8Ω LOAD] MEASURED WITH AC VTVM. VOLUME CONTROL MAXIMUM, ALL OTHER CONTROLS AND SWITCHES NORMAL.

POWER CONSUMPTION  
MIN. 20 W 30 VA  
MAX. 225 W 252 VA  
FOR RATED POWER,  
8-ΩHM LOAD.

SELECTOR (S3) SWITCH POSITIONS	
1	PHONO
2	FM LOCAL
3	FM
4	AM
5	AUX

5mm X 20mm FUSES		
F951	213005	F51B247-23
F952	213005	F51B247-23
F953	213.300	F51B247-10
F954	213001	F51B247-15

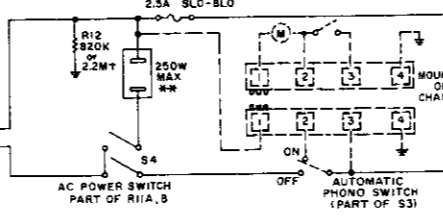

- \* MOUNTED ON POWER SUPPLY BOARD
- \*\* NOT USED ON EXPORT UNITS
- † USED ON EXPORT UNITS ONLY
- ‡ NOT USED ON ALL UNITS
- § CASHED LINES INDICATE PARTS USED IN 25R CONSOLE CHASSIS.

AW 2787  
P1690

# (400-T) MAIN CHASSIS – AMPLIFIER SECTION

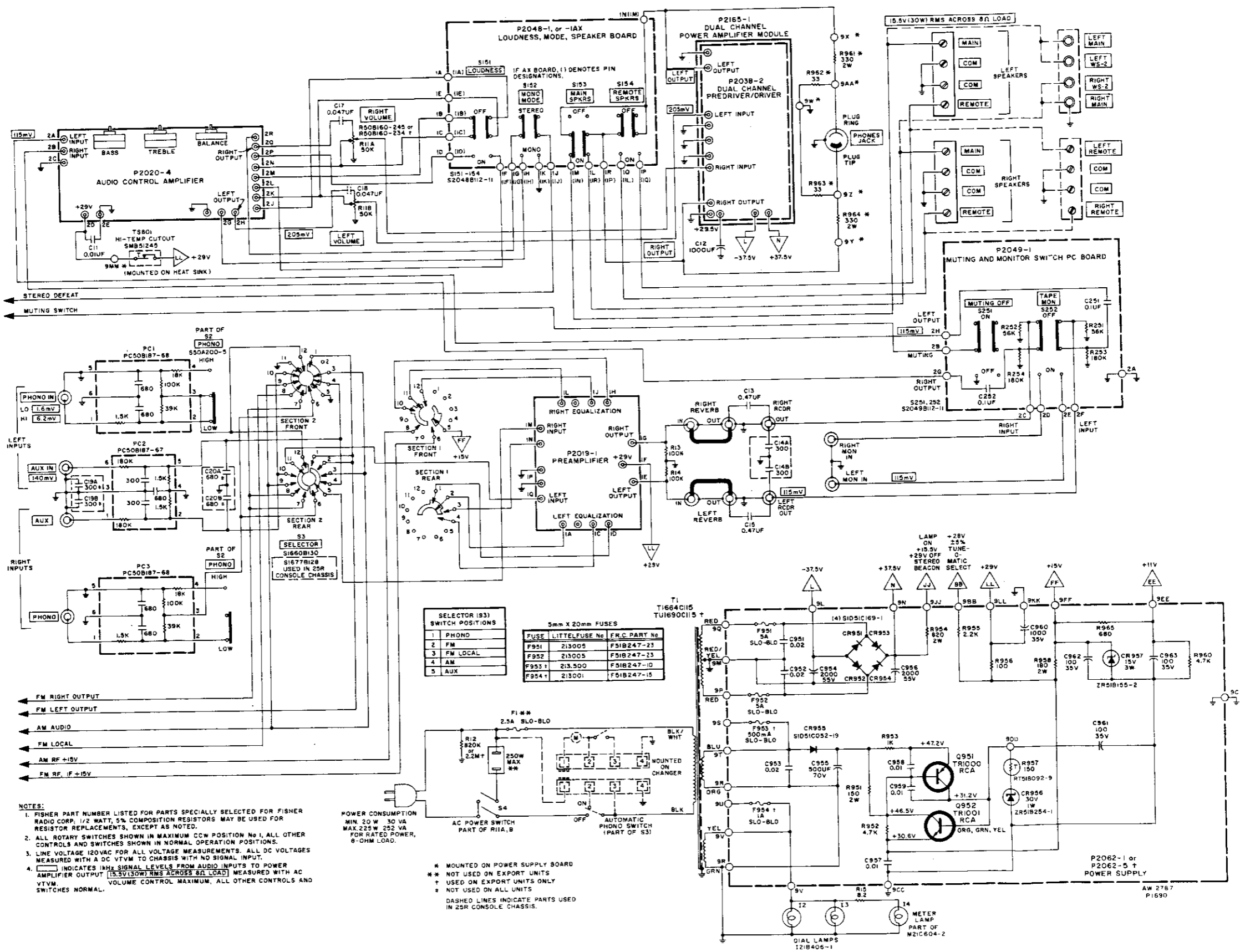

- NOTES:**
1. FISHER PART NUMBER LISTED FOR PARTS SPECIALLY SELECTED FOR FISHER RADIO CORP. 1/2 WATT, 5% COMPOSITION RESISTORS MAY BE USED FOR RESISTOR REPLACEMENTS, EXCEPT AS NOTED.
  2. ALL ROTARY SWITCHES SHOWN IN MAXIMUM CCW POSITION No 1, ALL OTHER CONTROLS AND SWITCHES SHOWN IN NORMAL OPERATION POSITIONS.
  3. LINE VOLTAGE 120VAC FOR ALL VOLTAGE MEASUREMENTS. ALL DC VOLTAGES MEASURED WITH A DC VTVM TO CHASSIS WITH NO SIGNAL INPUT.
  4. [ ] INDICATES 15.5V (30W) RMS ACROSS 8Ω LOAD TO POWER AMPLIFIER OUTPUT. [ ] INDICATES 15.5V (30W) RMS ACROSS 8Ω LOAD TO POWER SUPPLY. VOLUME CONTROL MAXIMUM. ALL OTHER CONTROLS AND SWITCHES NORMAL.

**SELECTOR (S3) SWITCH POSITIONS**

1	PHONO
2	FM
3	FM LOCAL
4	AM
5	AUX

**5mm X 20mm FUSES**

FUSE	LITTEL FUSE No	F.H.C. PART No
F951	213005	F51B247-23
F952	213005	F51B247-23
F953	213.500	F51B247-10
F954	213001	F51B247-15

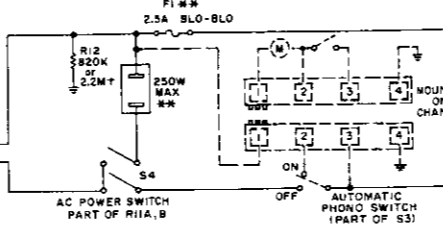

**POWER CONSUMPTION**  
 MIN 20 W 30 VA  
 MAX 225 W 252 VA  
 FOR RATED POWER, 8-ΩHM LOAD.

- \* MOUNTED ON POWER SUPPLY BOARD
- \*\* NOT USED ON EXPORT UNITS
- † USED ON EXPORT UNITS ONLY
- ‡ NOT USED ON ALL UNITS
- DASHED LINES INDICATE PARTS USED IN 25R CONSOLE CHASSIS.

AW 2787  
 P1690

(400-T) COMPONENT CONNECTIONS

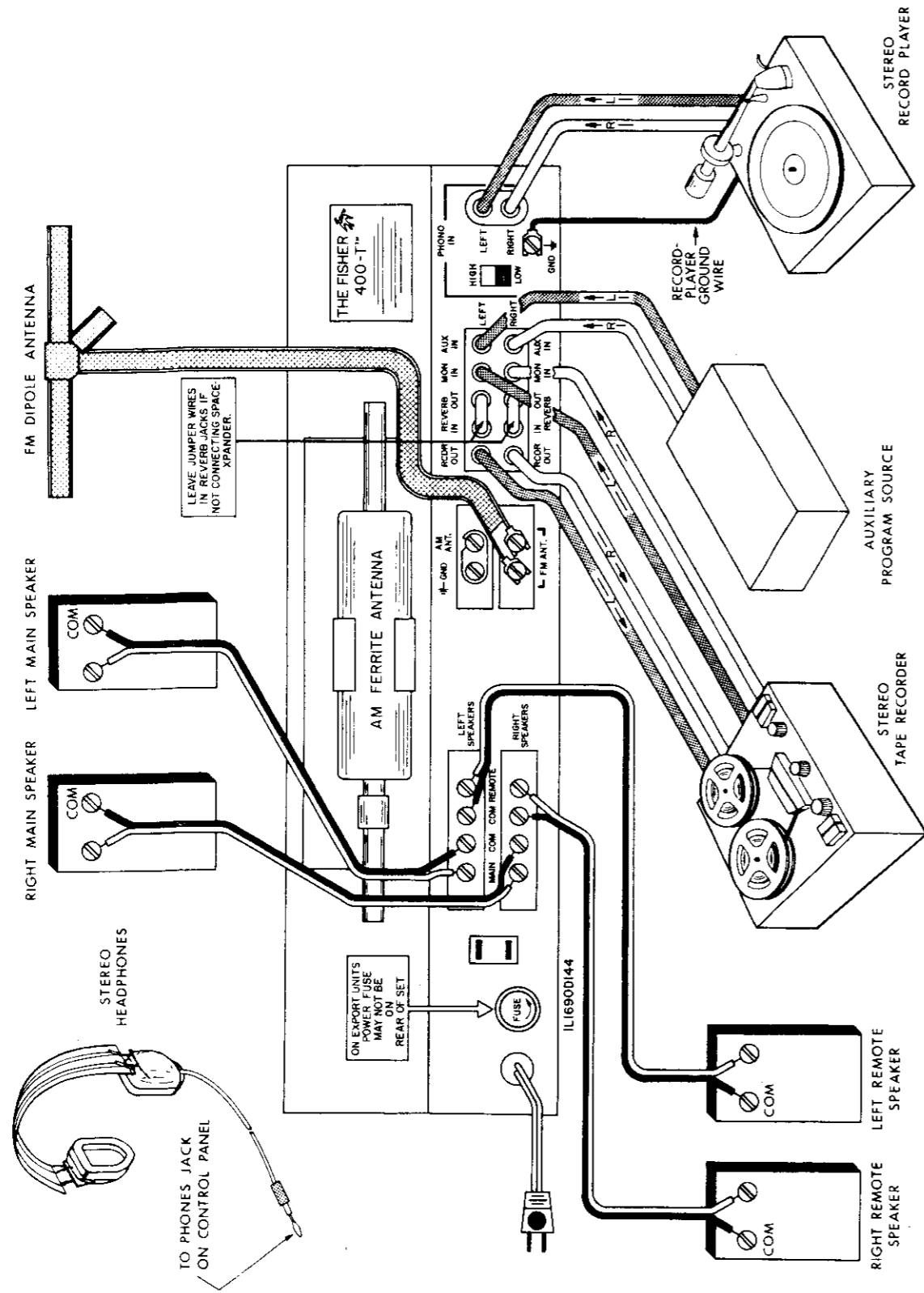

(250-T) COMPONENT CONNECTIONS

