

INSTRUCTION MANUAL
FOR THE
RX METER TYPE 250-A

726



NOTICE RESERVE
SERVICE ELECTRONIC
ENTAILING

BOONTON RADIO CORPORATION
BOONTON, NEW JERSEY
U. S. A.

INSTRUCTION MANUAL
FOR THE
RX METER TYPE 250-A



Distributeurs exclusifs pour la France
et l'Union Française
RADIO - ÉQUIPEMENTS
65, Rue de Richelieu, PARIS-2^e
RIG. 49-88

BOONTON RADIO CORPORATION
BOONTON, NEW JERSEY
U. S. A.

CONTENTS

1. Description	
A. General	7
B. Specifications	7
C. Front Panel Controls & Indicators	7
D. Measuring Terminals	8
E. Application	8
II. Operation	
A. Preparation for Use	9
B. Preliminary Procedure	9
C. Measurement Procedure	9
III. Interpretation of Results	
A. Significance of Dial Readings	10
B. Extension of Results	10
C. Sources of Error	10
IV. Theory of Operation	
A. Overall Operation	12
B. The Bridge Circuit	12
C. The Oscillator Unit	13
D. Mixer Stage	14
E. Amplifier	14
F. Power Supply	14
V. Maintenance & Adjustment	
A. Trouble Shooting	14
1. Removal from Cabinet	14
2. Trouble Shooting Chart	15
B. Adjustments	
1. Bridge Trimmer Adjustment	16
2. Reduction of Signal Level	16
Appendix A. Extension of Ranges	
1. Low Resistance	18
2. Low Inductance	18
3. High Capacitance	19

CONTINUED ON FOLLOWING PAGE.

CONTENTS-Continued

Appendix B. Installation and Use of Co-ax Adapter Type 515-A

1. Specifications	19
2. Equipment Supplied	20
3. Installation Procedure	20
4. Preliminary Adjustment of RX Meter with Adapter Installed	21
5. Application	
a. Remote Measurements	21
b. Transmission Line Characteristics	22
6. Normal Measurements with Adapter Plate in Place	22

Appendix C. Special Applications

1. Coaxial Transmission Line Characteristics	22
2. Balanced Transmission Line Characteristics	24
3. Vacuum Tube Input Impedance	25
4. Measurement of non-Linear Impedances	25
5. Use as Harmonic Analyzer	26
6. Method of Applying DC Bias	26

LIST of ILLUSTRATIONS

SECTION	FIGURE NO.	TITLE	PAGE
IA	1	Photo 250-A Front View (control call-outs)	6
IE	2	Typical resistor measurements	7
IE	3	Inductance measurement range	8
IIC	4	Correction chart for C_p capacitor inductance	11
IIC	5	K factor chart	11
IVA	6	250-A block diagram	12
IVB	7	Schering bridge circuit	12
IVC	8	Oscillator-to-bridge coupling circuit	13
IVC	9	Simplified bridge circuit	13
VA	10	Photo 250-A top view with panel removed	15
VA	11	Voltage check chart	16
VA	12	Photo Rear view of oscillator & bridge assemblies	17
VB1	13	Photo Adjustment of bridge trimmer	17
VB2	14	Terminal voltage reduction-circuit alteration	18
VB2	15	Diagram of circuit alteration	18
Appendix B	B-1	Photo 515 Adapter Kit	20
	B-2	RX Meter terminal plate - plan view	20
	B-3	Terminal plate with adapter installed - plan view	20
	B-4	Photo 515 Adapter installed	21
Appendix C	C-1	Length-vs-frequency chart-polyethylene dielectric cable	23
	C-2	Diagram of 1/2 wavelength balun	24
	C-3	Typical circuit for measuring vacuum tube input impedance on RX Meter	25
	C-4	Typical circuit for measuring crystal diodes on RX Meter	26
	C-5	Network for coupling external signal to RX Meter for harmonic analysis	26
	C-6	Method of applying DC biasing current less than 50 ma.	26
	C-7	Method of applying biasing current greater than 50 ma.	26
		Series-Parallel Conversion Chart	28
		250-A Schematic Diagram is contained at rear of Manual	

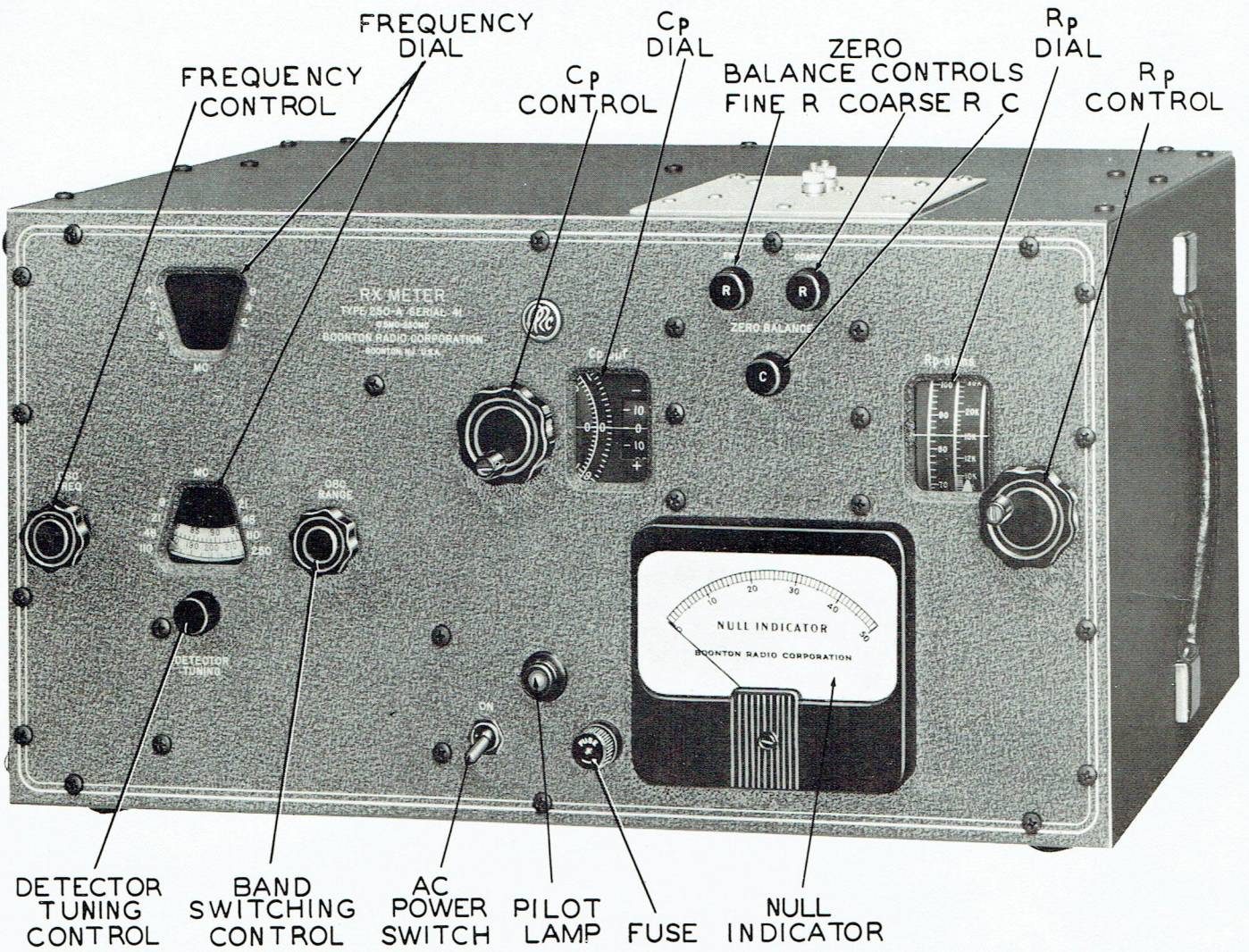

Figure 1 250-A Front View (control call-outs)

I. DESCRIPTION

A. GENERAL

The RX Meter Type 250-A is a wide frequency range Impedance Meter designed to permit accurate individual determination of the equivalent parallel resistance and parallel reactance of two-terminal networks and components. The instrument is completely self-contained and consists, fundamentally, of a refined Schering bridge circuit, together with its associated oscillator, detector, amplifier, null detector and power supply. Bridge balance is obtained by means of two calibrated dials which indicate, respectively, parallel resistance and parallel capacitance of the unknown.

B. SPECIFICATIONS

1. FREQUENCY RANGE: 0.5 mc to 250 mc.
2. RESISTANCE MEASUREMENTS:
 - a. Range: 15 ohms to 100,000 ohms.
(Values from 0 to 15Ω may be measured indirectly.)
 - b. Accuracy:

$$\pm \left(2 + \frac{f}{200} + \frac{R_p}{5000} + \frac{Q}{20} \right) \% \pm 0.2 \text{ ohms}$$

where f = frequency in megacycles

R_p = equivalent parallel resistance in ohms indicated by RX Meter

$$Q = \frac{R_p}{X_p}$$

as determined from RX Meter readings.

3. CAPACITANCE MEASUREMENTS:
 - a. Range: 0 to 20 mmf. (May be extended to 120 mmf by use of auxiliary resonating coils.)
 - b. Accuracy: $\pm(0.5 + 0.5F^2 * C * 10^{-5})\% \pm 0.15 \mu\text{mf}$
*F = frequency (MC); C = RX Meter Cp reading (μmf)

where f = frequency in megacycles.

4. INDUCTANCE MEASUREMENTS:
 - a. Range: Inductance values which will resonate with capacitance from 0.1 mmf to 100 mmf over the frequency range of the instrument. By the use of auxiliary series resistors or capacitors, values of inductance may be measured over the following ranges.

Freq.	Minimum	Maximum
0.5 mc	0.01μh	100 mh
250 mc	0.001μh	0.4 mh

5. VOLTAGE AT TEST TERMINALS:

DC voltage = 0. (DC up to 50 ma. may be passed thru the terminals from external source.)
RF voltage = approximately 0.1 to 0.5 volts.

6. POWER REQUIREMENTS:

Voltage, 105-125 volts; frequency, 50-60 cps, power consumption, 60 watts. (Voltage internally regulated.)

7. TUBE COMPLEMENT:

- 2 Type 5718
- 1 Type 6AB4 (low noise tube required)
- 2 Type 6AG5
- 1 Type OD3
- 1 Type 5Y3
- 1 Type 6H-6

8. OVERALL DIMENSIONS:

Height, 10 inches; length, 20 inches; depth 12 inches.

9. NET WEIGHT: 40 lbs.

10. AUXILLIARY EQUIPMENT REQUIRED: None.

11. OPTIONAL AUXILLIARY EQUIPMENT:

CO-AX ADAPTER KIT TYPE 515-A

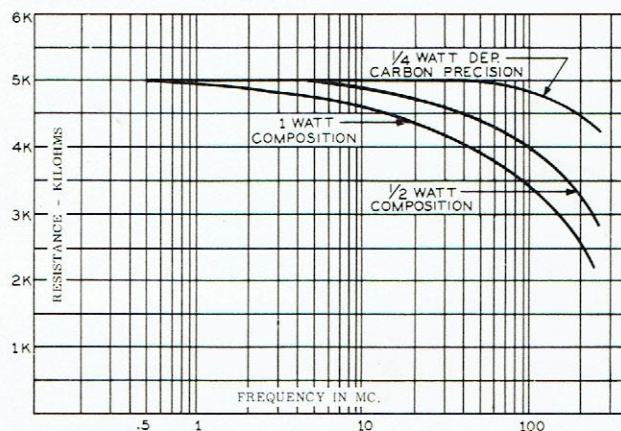

Figure 2 Typical resistor measurements

C. FRONT PANEL CONTROLS AND INDICATORS

SEE FIG. 1

1. OSC. FREQ: Drives ganged oscillator capacitors C305* and C321, to control oscillator frequency continuously through eight available ranges. Selected frequency (in mc) is displayed on unmasked portion of range indicator dial.
2. OSC. RANGE: Rotates oscillator turrets and range indicator mask to select one of eight available frequency ranges.
3. DETECTOR TUNING: Controls setting of trimmer capacitor C320, providing fine adjustment of local oscillator frequency for proper IF output to tuned detector.
4. C_p μmf : Control knob with associated disk-and-drum indicator. Drives bridge capacitor C111, to provide up to +20 μmf or -100 μmf for balancing the bridge and measuring the parallel reactance of sample.
5. ZERO BALANCE: Fine R, Coarse R and C controls (R112, R107 and C107, respectively).

*Component symbols refer to schematic diagram located at back of manual.

- Provide for initial balancing of bridge circuit.
6. ON: Single-throw toggle switch (S501). Controls power to all plates and filaments. Pilot lamp above switch lights with power on.
 7. FUSE: Fuse post containing 1 1/2 amp fuse for protection of power transformer primary.
 8. NULL INDICATOR: Microammeter (0-200 μ a). Reads amplified unbalance current from bridge circuit. Null (minimum) reading indicates bridge balance.
 9. R_p OHMS: Drum indicator and associated drive knob. Indicates setting of variable capacitor C103, which balances out parallel resistive component of sample impedance. Helical scale is graduated in ohms from 15 to infinity. Effective portion of scale is indicated by a pointer.

D. MEASURING TERMINALS

Impedances to be measured are connected to the RX Meter by means of the binding posts mounted on the terminal plate of the instrument. The front post is insulated from ground and is marked "HI"; and the rear post is grounded to the cabinet and is marked "LO". An RF voltage of approximately 0.1 to 0.5 volts appears across these terminals. This voltage may be reduced for special measuring applications. The DC resistance looking into the terminals is approximately 66 ohms.

NOTE: Easy and quick change connection of coaxial lines and fittings equipped with Type N connectors may be readily made by means of the Coax-Adapter Kit Type 515A (See Appendices).

E. APPLICATION

Because the RX Meter measures, individually, the parallel resistance and reactance components of an impedance, rather than the absolute impedance and because it makes available a broad frequency band and relatively wide measurement range, the instrument is a particularly valuable research and development tool.

The field of application for the RX Meter is a broad one, including measurement of a wide variety of components and networks such as resistors, attenuators, antennas, cables, transformers, inductors, capacitors, filters, vacuum tubes, varistors, thermistors, diodes and transistors. The instrument is adaptable to the measurement of high- and medium-loss insulating materials such as phenolic tube bases and may be applied to the determination of the electrical properties of many chemical compounds and solutions.

The measurement of equivalent parallel resistance is of considerable importance, since it represents the impedance seen by a vacuum tube or transistor when working into a parallel tuned circuit as an amplifier or oscillator. A direct measurement of R_p also facilitates the determina-

tion of power dissipation in a tuned circuit, since then, by merely measuring the voltage (E) developed across the tank, Power Dissipated = E^2/R_p . The direct measurement of R_p is also of interest to those working with magnetic materials such as ferrites, powdered iron and permalloy, since the quality factor μQ (permeability $\times Q$) has been shown to be directly proportional to the R_p of a test winding.

Valuable data on the relative characteristics of various types of resistors at VHF is readily obtainable with the RX Meter. Figure 2 illustrates typical resistance vs frequency characteristics for three commercially-available 5000 ohm resistors, as measured on this instrument.

In addition to measuring parallel resistance and equivalent capacitance, the RX Meter can be used to measure small inductance values with a readability, in some cases, of 0.0001 microhenry, by extending the measuring range as described on page 18. Figure 3 indicates on an ordinary reactance chart the available range of inductance measurements, from 100 millihenries down to 0.0001 microhenry.

A further application of the RX Meter, unrelated to the impedance measurements described above, is the analysis of the harmonic content of RF signals. This application is described in Appendix C.

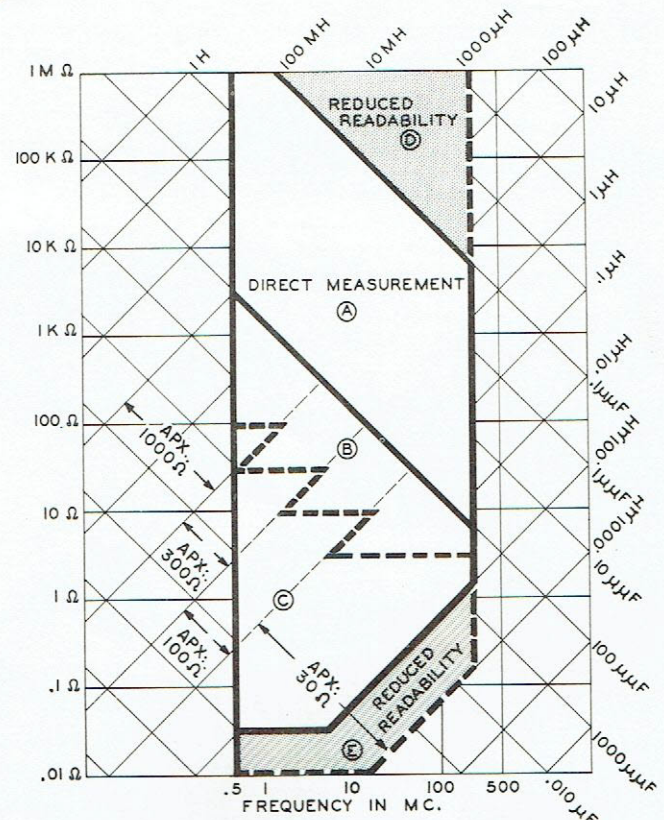

Figure 3 Inductance measurement range

II. OPERATION

A. PREPARATION FOR USE

1. The RX Meter has been carefully packed and should be carefully inspected upon receipt for possible physical damage incurred in shipment. Any such damage should be reported immediately to Boonton Radio Corporation.
2. The instrument is ready for use as soon as it is removed from the shipping container. Before plugging in the power cord, make sure the line voltage and frequency correspond to those designated on the voltage plate mounted on the back of the instrument.

B. PRELIMINARY PROCEDURE

1. If necessary, adjust the mechanical zero of the null indicating meter before turning the power on.
2. Turn the power on and allow the instrument to warm up for about ten minutes (extra time is sometimes required to attain satisfactory stability above 110 mc.).
3. Select the desired measuring frequency by means of the OSC RANGE and OSC FREQ controls. Note that the active range is indicated by a pointer mounted on one side of the indicator mask.
4. Set the C_p dial to "0" and the R_p dial to " ∞ ". Make sure that the pointer indicates the proper scale sector.
5. Unbalance the bridge circuit by placing two fingers across the binding posts, and adjust the DETECTOR TUNING knob until a maximum deflection is obtained on the NULL INDICATOR. This deflection should have a magnitude of about 35 scale divisions. A peak of substantially less than this amount is usually an indication of an unusable harmonic response instead of the desired fundamental. At higher frequencies two fundamental frequency peaks will be observed, either of which represents satisfactory tuning of the detector. Between the fundamental peaks will be found several secondary, or harmonic, peaks which may be recognized by their relative sharpness and low amplitude. Care should be taken not to tune for one of these harmonics, since it will produce erroneous readings or make bridge balance impossible. When maximum meter deflection has been obtained, remove fingers from across the binding posts and tighten the binding posts nuts.
6. Adjust the three ZERO BALANCE controls, (fine R, Coarse R, and C), alternately, until a minimum deflection is obtained on the null indicator. This minimum deflection (indicating bridge balance) will vary from about 0.5 to 3

scale divisions, depending on the frequency used. At frequencies above 100 mc, the COARSE R control should be adjusted to approximately its mid-point position before a null is sought. If this control is set fully clock-wise it may be impossible to obtain balance. It will be noted that a slight interaction exists, at high frequencies, between the FINE R and C controls. For this reason it is important to use all three controls in obtaining final balance. When an apparent null has been obtained, the circuit should be tested for true balance by slowly rocking the R_p dial above and below the setting and observing the NULL INDICATOR. If a deeper null exists at some R_p value other than ∞ , the R_p dial should be returned to the latter indication and a new balance obtained with the ZERO BALANCE controls.

7. The above procedure establishes maximum bridge sensitivity at a given frequency and usually need not be repeated for successive measurements at this frequency. Whenever the measuring frequency is changed, however, steps 3 through 6 should be repeated.

C. MEASUREMENT PROCEDURE

1. Connect the component to be measured to the RX Meter binding post. Note that the LO (grounded) post is the one nearest the rear of the cabinet. The leads should be kept as short as possible and stray capacitance between the component and the top of the RX Meter cabinet should be minimized and kept constant.
2. If the impedance of the test component is known to be primarily resistive, adjust the R_p control until a minimum deflection is obtained on the NULL INDICATOR. Then adjust the C_p and R_p controls alternately until a final null point is reached.
3. If the impedance of the test component is known to be reactive, adjust the C_p control first to obtain an initial minimum; then the R_p and C_p controls alternately to obtain final balance.
4. Read the equivalent parallel resistance of the component (as seen at the binding posts) from that sector of the R_p dial indicated by the pointer.
5. Read the positive or negative resonating capacitance of the component (in $\pm\mu\mu\text{f}$) from the C_{p2} dials. If the component is capacitive, the indication will fall in the yellow (+) portion of the drum scale and the corresponding yellow (inner) scale of the vernier disk which together provide a direct indication of parallel capacitance. If the component is predominantly inductive, the dial will read in the white (-) portion and, with the white vernier scale, provides a reading in

$-\mu\text{mf}$. This value represents the capacitance which resonates with the parallel inductance of the component at the frequency used. Then $X_p = \frac{1}{2\pi f C_p}$

NOTE: The procedure outlined here is, in general, that followed in making a normal measurement with the RX Meter. A more de-

tailed discussion of the techniques involved in a number of specific measurements will be found in the appendices at the back of this manual. The user will evolve the most satisfactory procedures for his own specialized applications as he becomes familiar with the operation of the instrument.

III. INTERPRETATION OF RESULTS

A. SIGNIFICANCE OF DIAL READINGS

The RX Meter yields results which are read in terms of parallel resistance (R_p) and positive or negative parallel capacitance (C_p). An R_p reading is a direct indication of the effective parallel resistance component of the unknown impedance as seen at the RX Meter binding posts. A positive capacitance reading (made on the yellow portion of the C_p dial, marked "+") indicates directly the effective parallel capacitance of a capacitive impedance. A negative capacitance reading (made on the white portion of the C_p dial, marked "-") indicates the capacitance which resonates with the effective parallel inductance of an impedance. In the latter case, the effective parallel inductance may then be determined by the simple relation,

$$L_p = \frac{1}{\omega^2 C_p}$$

It should be kept in mind that the RX Meter measures the above values as they appear at its binding post. For this reason, the connecting leads should always be kept as short as possible in order to minimize the effect of their residual resistance and inductance.

B. EXTENSION OF RESULTS

The remaining basic parameters of the impedance measured may be readily obtained by simple computation from frequency setting and the values of R_p and C_p indicated by the RX Meter. The relationships involved are as follows.

- a. Equivalent parallel reactance (X_p)

$$X_p = 1/\omega C_p \text{ (neglecting sign of } C_p) \quad (1)$$

- b. Equivalent parallel inductance (L_p)

$$L_p = X_p/\omega \text{ (for white portion of dial)} \quad (2)$$

- c. Q

$$Q = R_p/X_p \quad (3)$$

- d. Equivalent series resistance (R_s)

$$R_s = \frac{R_p}{1 + Q^2} \quad (4)$$

and, with less than 1% error

$$R_s = X_p^2/R_p, \text{ when } Q > 10 \quad (4a)$$

$$R_s = R_p, \text{ when } Q < 0.1 \quad (4b)$$

- e. Equivalent series reactance (5)

$$X_s = \frac{X_p Q^2}{1 + Q^2}$$

and, with less than 1% error

$$X_s = X_p, \text{ when } Q > 10 \quad (5a)$$

$$X_s = R_p^2/X_p, \text{ when } Q < 0.1 \quad (5b)$$

- f. Absolute Impedance (6)

$$Z = \sqrt{\frac{R_p^2}{1 + Q^2}}$$

- g. Series Inductance (L_s) (7)

$$L_s = \frac{C_p R_p^2}{1 + Q^2}$$

and, with less than 1% error,

$$L_s = 1/\omega^2 C_p, \text{ when } Q > 10 \quad (7a)$$

$$L_s = C_p R_p^2, \text{ when } Q < 0.1 \quad (7b)$$

- h. Series capacitance (C_s) (8)

$$C_s = C_p(1 + 1/Q^2)$$

and, with less than 1% error,

$$C_s = C_p, \text{ when } Q > 10 \quad (8a)$$

$$C_s = \frac{1}{R_p^2 \omega^2 C_p} \text{ when } Q < 0.1 \quad (8b)$$

C. SOURCES OF ERROR

The RX Meter measuring circuit includes two residual parameters which may, in certain cases, cause minor errors in results. When warranted by the nature and desired accuracy of the

measurements at hand, known corrections may be applied to nullify these errors. In most practical applications, however, it will probably be found that these errors may be disregarded.

1. Series Inductance of C_p Capacitor (C111)

Inductance values (i. e. those read on the white portion of the C_p dial) may be corrected for the residual series inductance of the C_p capacitor by adding the appropriate value of ΔC , as determined from Figure 4, to the indicated value of C_p . Positive capacitance measurements (read on the yellow portion of the dial) require no correction for this effect.

EXAMPLE: At 200 mc a small inductance measured on the RX Meter produces a C_p reading of $-65 \mu\text{mf}$. Referring to Figure 4, it is found that a correction of $-6 \mu\text{mf}$ is required. Thus, true $C_p = -65 - 6 = -71 \mu\text{mf}$.

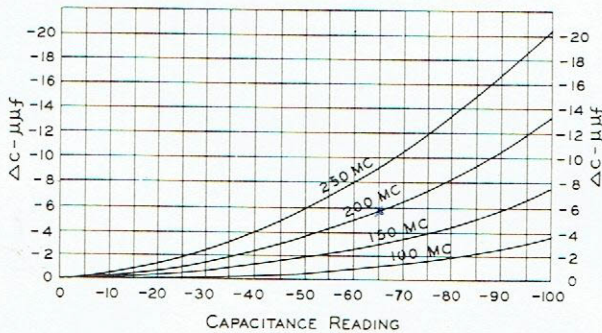

Figure 4 Correction chart for C_p capacitor inductance

2. Residual Series Inductance of Binding Posts

When relatively low values of impedance are measured on the RX Meter, the series inductance of the binding posts (approximately $0.003 \mu\text{h}$) may have an appreciable effect on the results. The true value of R_p may be computed from the following formula:

$$\text{True } R_p = \frac{R_p}{1 - \frac{C_p}{K}}$$

where R_p (in ohms) and C_p (in μmf) are the values read on the RX Meter and K is one-half the resonating capacitance of the binding post inductance as determined from Figure 5.

EXAMPLE: A low value, $1/2$ watt resistor, measured at 200 mc produces the following readings: $R_p = 29.0 \Omega$, $C_p = -25.6 \mu\text{mf}$. Find the true R_p .

$$\text{True } R_p = \frac{R_p}{1 - \frac{C_p}{K}} = \frac{29}{1 - \frac{-25.6}{100}} = 23.1 \Omega.$$

Low values of parallel reactance, as measured on the RX Meter, may also be affected by the binding post inductance. Indicated positive capacitance values may be corrected for this effect by the following relation:

$$C_p(\text{true}) = \frac{C_p}{1 + \omega^2 L C_p}$$

where $\omega = 2\pi f$

$L = 0.003 \times 10^{-6}$ (henries)

$C_p = \text{RX Meter reading} \times 10^{-12}$ (farads).

A negative capacitance (inductance) reading may be corrected by determining the corresponding parallel inductance value ($L_p = 1/\omega^2 C_p$) and parallel reactance ($X_p = 1/\omega C_p$) and converting to the equivalent series form by the general formula (eq. 5).

$$L_s = \frac{C_p R_p^2}{1 + Q^2}$$

where C_p and R_p are read directly on the RX Meter, and

$$Q = R_p / X_p.$$

The corrected inductance value is then obtained by subtracting from the above quantity the binding post series inductance of $0.003 \mu\text{h}$.

EXAMPLE: It is desired to find the inductance of the resistor used in the preceding example. Given, $R_p = 29.0 \Omega$, and $C_p = -25.6 \mu\text{mf}$. Applying the formulas above, $L_p = 0.025 \mu\text{h}$, and $X_p = 31.2 \Omega$. Then $L_s = 0.011 \mu\text{h}$ (by eq. 7), and the corrected inductance of the resistor = $0.011 - 0.003 = 0.008 \mu\text{h}$.

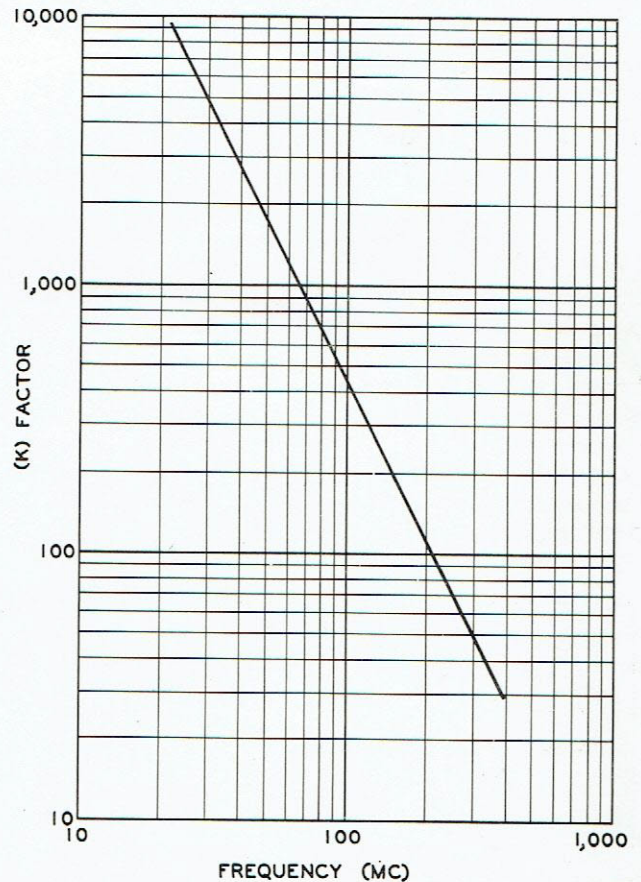

Figure 5 K factor chart

IV. THEORY OF OPERATION

A. OVERALL OPERATION

The basic operation of the RX Meter Type 250-A may best be described by referring to the block diagram of Figure 6. The output of the signal oscillator, continuously variable in frequency from 0.5 to 250 mc, is coupled directly into the bridge circuit. The unknown impedance is connected in parallel across one arm of the bridge. When unbalance occurs, a voltage proportional to the amount of unbalance is applied to the mixer where it is mixed with the output of the detector oscillator. The latter is gang-tuned with the signal oscillator and its output is maintained at 100 kc above the main signal frequency. When both signals are applied to the modulator, therefore, a 100 kc beat note is produced which is fed through a selective, high gain amplifier and applied to the null indicating meter. When the bridge circuit is balanced (in both amplitude and phase), no signal from the main oscillator will be applied to the modulator and no 100 kc signal will be produced. Thus a minimum indication on the null meter signifies a balanced condition.

Delayed automatic gain control by means of feedback is used to keep the null indicator from going off scale, even when the bridge is at maximum unbalance thus providing continuous sensing. Maximum gain of the amplifier is used only when the bridge is very close to the balanced condition.

In making a measurement on the RX Meter the bridge circuit is first balanced with nothing connected to the measuring terminals. This is done by means of three ZERO BALANCE controls (Coarse R, Fine R and C). With the unknown impedance connected to the terminals, final measuring balance is obtained by alternate adjustment of the R_p and C_p controls. The resistive and reactive components of the unknown impedance may then be determined from the R_p and C_p dial readings.

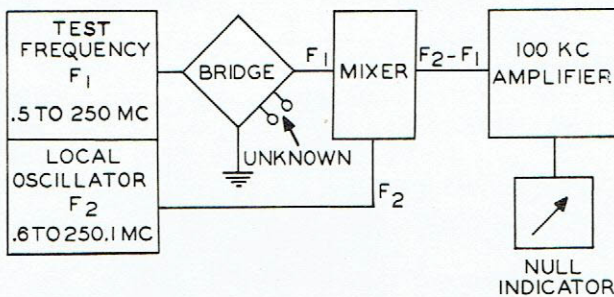

Figure 6 250-A block diagram

B. THE BRIDGE CIRCUIT

The modified Schering Bridge circuit used in the RX Meter was selected primarily because of the following characteristics:

1. A virtually constant relationship between the bridge elements is maintained, regardless of the frequency impressed on the network.
2. Both of the basic variable bridge elements are air capacitors, which are definitely superior to other types of variable impedances for high frequency measurement work.
3. The circuit residual impedance is small enough to permit compensation over a wide frequency band.
4. Because parallel impedance components are measured, shielding problems are considerably reduced.

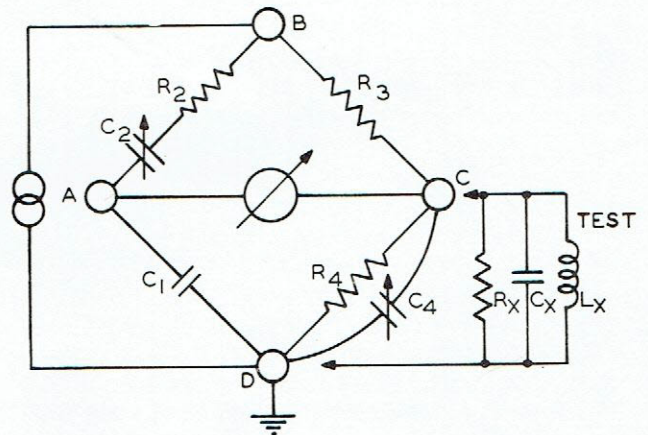

Figure 7 Schering bridge circuit

The simplicity and wide frequency range of this bridge network can be appreciated by an analysis of the impedance relationships for the balanced condition. Referring to Figure 7,

$$Z_{AB} Z_{CD} = Z_{AD} Z_{BC} \text{ at balance,}$$

or

$$\left(R_2 + \frac{1}{j\omega C_2} \right) \left(\frac{1}{\frac{1}{R_4} + j\omega C_4} \right) = \frac{R_3}{j\omega C_1}$$

$$R_2 + \frac{1}{j\omega C_2} = \frac{R_3}{j\omega C_1} \left(\frac{1}{R_4} + j\omega C_4 \right)$$

$$= \frac{R_3}{j\omega C_1 R_4} + \frac{C_4 R_3}{C_1}$$

Equating reals...

$$R_2 = \frac{C_4 R_3}{C_1}, \text{ and } \frac{R_2}{C_4} = \frac{R_3}{C_1}$$

Handwritten note: $\frac{R_3}{C_1} = \frac{1}{C_2}$

Equating imaginaries...

$$\frac{1}{j\omega C_2} = \frac{R_3}{j\omega C_1 R_4}$$

$$\frac{R_3}{C_1} = \frac{R_4}{C_2}$$

$$\therefore \frac{R_2}{C_4} = \frac{R_3}{C_1} = \frac{R_4}{C_2} \tag{1}$$

The unknown impedance is connected across corners C and D of the bridge, and its parallel components of resistance and reactance effectively change the values of C4 and R4 in the circuit. In order to restore phase and amplitude balance conditions, the variable bridge capacitor C4 must be decreased by an amount equal to the equivalent parallel capacitance of the test sample. If the test sample is inductive, the capacitance of C4 is increased by an amount equal to the resonating capacitance of the parallel inductances.

The parallel resistance of the test is shunted across R4, reducing its value by a certain percentage which changes the R4/C2 ratio and unbalances the bridge. To restore phase and amplitude balance, variable capacitor C2 is reduced in value by the same percentage that R4 was reduced when shunted by the test resistance. The variable capacitor C2 can thus be calibrated directly in terms of the parallel resistance (in ohms) of the component being measured.

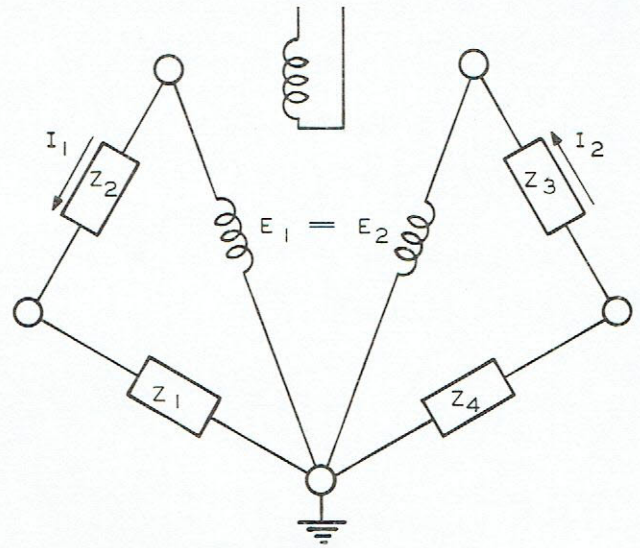

Figure 9 Simplified bridge circuit

C. THE OSCILLATOR UNIT

The dual oscillator unit consists of two separate, modified Colpitts oscillators, constructed on a single aluminum casting. Ganged turrets provide for band switching with a single control, and the tuning capacitors are also ganged to provide a constant difference frequency of 100 kc. between the signal and detector oscillator. A manually adjustable trimmer condenser (DETECTOR TUNING, C320) is provided in the detector oscillator to adjust for tracking deviations caused by temperature, aging of tubes, and slight mis-alignment of tuning capacitors. Sub-miniature tubes type 5718 are used in both oscillators because of their high power, small size and long rated life.

The output of the signal oscillator is coupled into the bridge circuit by means of a specially devised transformer which overcomes the limitations imposed by more conventional coupling methods. The design of this transformer is illustrated in Figure 8. It will be noted that the bridge network is divided into two halves, one half being driven by voltage E1 and the other by E2. Assume that voltages E1 and E2 are exactly equal in magnitude but opposite in phase, thus producing instantaneous currents I1 and I2 in the direction indicated. This arrangement makes it possible to detect bridge balance conditions by coupling to the null detector through two very small but exactly equal capacitors, ZB and ZC. In the balanced condition, voltage ED becomes zero, as indicated by the null detector, and the voltage across ZB is exactly equal to that across ZC. This is evident, since the same current, I3, flows through both ZB and ZC when zero current is drawn by the detector branch. Since X and G are at the same potential, it follows that

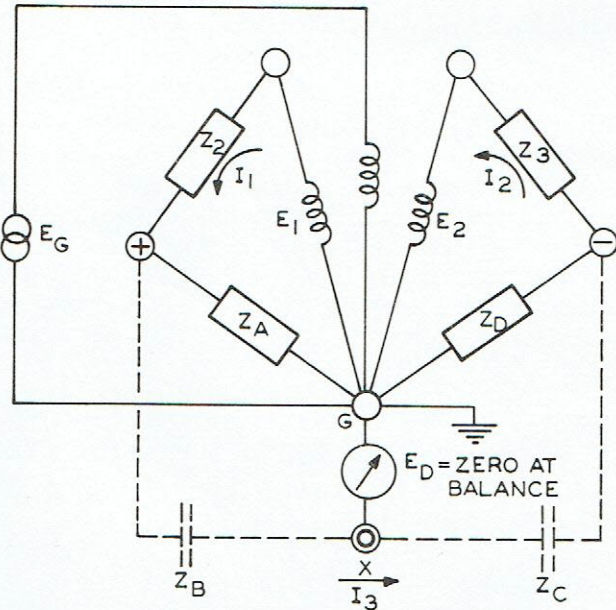

Figure 8 Oscillator-to-bridge coupling circuit

Z_B may be considered effectively in parallel with Z_A , and similarly C_2 is in parallel with Z_D . Thus the voltage across Z_A is equal to that across Z_D . Now let Z_A and Z_B in parallel = Z_1 , and Z_C and Z_D in parallel = Z_4 .

$$E_1 = I_1 Z_2 + I_1 Z_1$$

$$E_2 = I_2 Z_3 + I_2 Z_4$$

$$E_1 = E_2 \text{ (by design)}$$

and $I_1 Z_1 = I_2 Z_4$ at balance

then $I_1 Z_2 = I_2 Z_3$

$$\frac{I_1 Z_1}{I_1 Z_2} = \frac{I_2 Z_4}{I_2 Z_3} \text{ and } Z_1 Z_3 = Z_2 Z_4 \quad (2)$$

This impedance arm relationship is the same as that of a conventional bridge network.

D. MIXER STAGE

The mixer stage is constructed as an integral part of the bridge circuit in order to reduce to a minimum the length of connections between the capacitance coupling networks and the modulator tube grid. This is important in order to maintain voltage sensitivity with respect to the bridge corners. The 6AB4 triode was selected for this application because of its high transconductance, low input capacitance, and low noise factor. Noise level is an inherent problem in this stage because of the very high grid leak resistor required and

the 40 kc band width of the amplifier. For this reason excessively noisy tubes provide unsatisfactory performance and must be replaced.

E. AMPLIFIER

The two-stage 100 kc amplifier is designed with a wide (40 kc) passband to facilitate oscillator tuning and tracking but minimize response to spurious signals and harmonics. Delayed automatic gain control keeps the null indicator on scale at all times and provides maximum sensitivity at settings close to the balance point. The sensitivity of the null indicator has been kept high by reducing the value of the resistance in series with the meter and providing the required additional protection by means of a shunt crystal diode (CR202) across the meter circuit.

F. POWER SUPPLY

The RX Meter Power Supply is of conventional design employing a 780-volt centertapped power transformer with a 5Y3 full wave rectifier working into a choke input filter. Although hum level is not an important factor in the operation of the instrument, the choke is used to reduce the heating effect of high level AC ripple in the high voltage winding of the transformer. A 1-1/2 amp fuse protects the transformer primary windings.

An OD3 VR tube provides 150 VDC regulated for the oscillators and modulator. An amperite 6H-6 ballast tube is used to regulate the tube heater voltage. Unregulated B+ supplies the plate voltages for the 100 kc amplifier.

V. MAINTENANCE AND ADJUSTMENT

A. TROUBLE SHOOTING

The RX Meter is ruggedly constructed, and should provide long, trouble-free service under normal operating conditions. If minor trouble should develop it may probably be readily located and remedied by the user with the information supplied below. The RX Meter is a precision instrument, however, and certain adjustments of the bridge and oscillator circuits are extremely critical and should not be attempted in the field. If the trouble cannot be located or corrected by means of normal maintenance procedures and the information supplied here, the instrument should be returned to the factory for repair or readjustment.

1. REMOVAL FROM CABINET

The bridge and oscillator assemblies of the instrument are permanently fastened to the front panel and are removed from the cabinet as a unit. The power supply and amplifier are constructed on a separate chassis, located end-to-end in the rear

section of the cabinet and fastened to the bottom of the cabinet by four screws each. All four major subassemblies are interconnected by cables with removable plugs.

A large portion of any required maintenance, such as replacement of tubes, may be accomplished by removing the front panel (with bridge and oscillator) and top panel together. This may be done as follows:

a. Remove all 12 black Phillips screws from the top panel. (Do not remove or loosen any of the screws on the terminal plate.)

b. Remove the four Phillips screws from each side of the front panel and the three from along the bottom edge.

c. The top and front panels may now be tilted forward from the cabinet to provide access to the interior of the instrument. If it is desired to remove them entirely, the plug connections on the internal cables to the power supply and amplifier must first be disconnected.

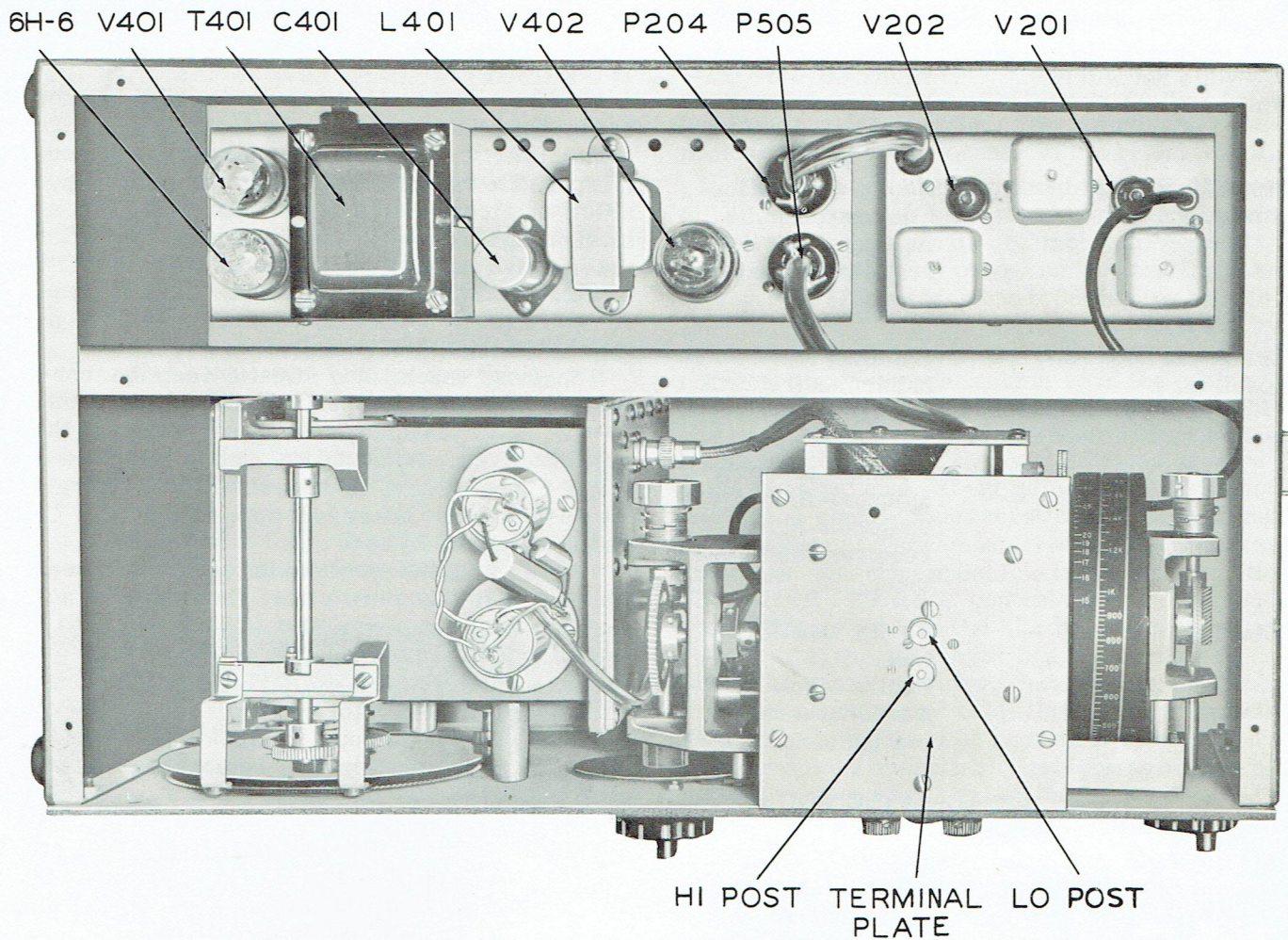

Figure 10

250-A top view with panel removed

In some cases it may be found more convenient to remove the top panel of the instrument in the following manner:

- a. Remove all 12 Phillips screws from the top panel.
- b. Loosen the outer two screws along each side edge of the terminal plate. These screws are captive and should not be loosened more than about two turns.
- c. Remove three of the four screws along the top edge of the front panel, leaving in place the screw immediately below the terminal plate.
- d. The top panel may now be slid directly back until clear of the terminal plate and removed.

CAUTION: Under no circumstances should the terminal plate be removed. Maintenance of the bridge circuit (except for the replacement of the modulator tube) should be performed only at the factory.

2. TROUBLE SHOOTING CHART
SYMPTOM POSSIBLE CAUSE

Erratic or jumpy meter reading, or increased null reading.	Noisy 6AB4 mixer tube (replace with low noise tube). Sticky meter.
No meter reading except visible noise effects.	Signal or detector oscillator not functioning (check V301, V302).
No meter reading.	Defective 6H-6 ballast tube. Amplifier inoperative (check V201, V202). Power supply inoperative (check rectifier, V401). Fuse blown. Defective meter.
Frequency unstable.	Faulty regulator tube (V402), oscillator tube or 6H-6.

(Trouble Shooting-continued)

6.3 volts not within limits.	Faulty 6H-6 or filaments presenting improper load.
150 volts not within limits.	Faulty OD3 or oscillator tubes drawing excessive current. (Max. drain is 40 ma..)
Bridge balance impossible.	Detector tuned for harmonic. (recheck tuning) Zero balance controls not properly adjusted-Bridge Trimmer (C101) requires readjustment.
Low Sensitivity	Faulty amplifier tube. Faulty 6H-6. Amplifier needs realignment.

B. ADJUSTMENTS

1. BRIDGE TRIMMER ADJUSTMENT

At frequencies above 100 mc the zero balance of the RX Meter circuit is necessarily sensitive to small variations in internal circuit capacitance. It is possible that minute shifts in the relative position of circuit components, caused by excessively rough handling in shipping, etc., may alter the effective capacity enough to make it impossible to obtain a null indication on the highest frequency range by adjusting ZERO BALANCE controls, "R" and "C".

In most cases, this situation can be corrected by the following screwdriver adjustments.

a. Allow the instrument to warm up, set the oscillator frequency at 200 mc, and adjust the detector tuning control as described under Operating Instructions (Section II page 9) with the Cp dial at zero and Rp at ∞.

b. Pry up the small metal cap located near the rear of the terminal plate. This provides access to a trimmer capacitor (C101) which has a vertical, slotted adjusting shaft.

c. Rotate the COARSE "R" knob and note whether the null indicator reading decreases with (a) clockwise or (b) counter-clockwise rotation.

d. With a screwdriver, rotate the trimmer shaft about 1/8 turn clockwise in case (a) above, counter-clockwise in case (b) above. Then remove the screwdriver* and try to obtain balance with the "R" and "C" knobs. If a null indication still cannot be obtained, rotate the trimmer another 1/8 turn in the same direction. Continue this procedure until balance can be obtained. (If balance has not been obtained after 2 or 3 full turns off the shaft, it is probable that the trouble is of another nature and the instrument should be returned to the factory for correction.)

e. Check the balance at a frequency of 250 mc and repeat the above adjustment if necessary. Replace metal cap.

* Correct null indications cannot be obtained while the screwdriver (or aligning tool) is near or in contact with the adjusting shaft.

2. REDUCTION OF SIGNAL LEVEL

The normal RF signal level of 0.1 - 0.5 volts which appears across the RX Meter terminals will be found to be excessive for certain special applications, such as measurement of vacuum tube or transistor input impedance. In some cases it is also desirable to be able to vary the applied voltage during a series of measurements. For such applications a simple circuit modification may be made by the user which will permit operation at levels as low as 20 millivolts with usable bridge sensitivity.

This modification consists merely of installing a 100,000 ohm, 2 watt potentiometer in the plate supply of the signal oscillator. The

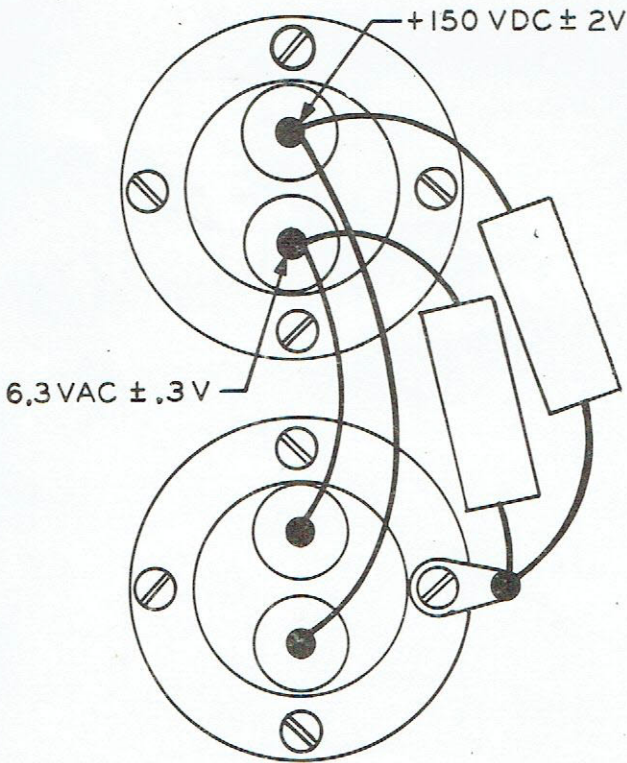

TOP OF OSCILLATOR CASTING

FRONT PANEL

Figure 11 Voltage check chart

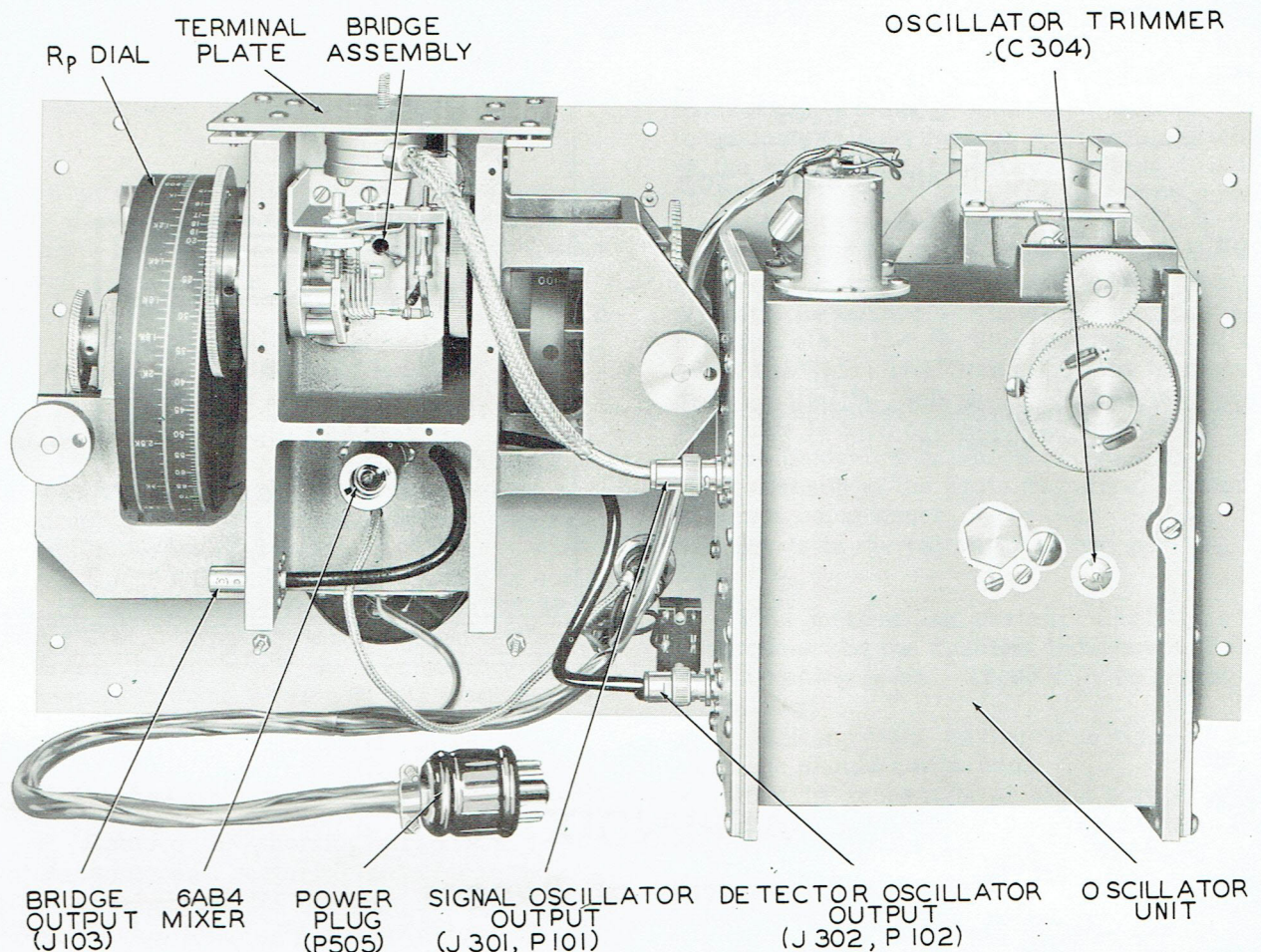

Figure 12 Rear view of oscillator & bridge assemblies

potentiometer serves as a voltage divider which lowers the oscillator plate voltage and thus reduces the oscillator output level. The installation may be made as follows:

- a. Remove the top panel of the RX Meter cabinet, as described in Section V-A, page 15.
- b. Mount a 100K, 2 watt potentiometer in one of the openings of the ventilation grid on the back of the cabinet.
- c. Disconnect the red-white lead from the signal oscillator RF filter (furthest from the front panel) and, substituting a longer lead, connect the terminal on this filter furthest from the front panel to one end terminal of the potentiometer.
- d. Connect the other end terminal of the potentiometer to the ground lug on the RF filter.
- e. Connect the center terminal of the potentiometer to the RF filter terminal from which the red-white lead was removed.
- f. Replace the cabinet top panel.

The potentiometer may then be adjusted to provide the desired RF signal level across the measuring terminals, as indicated by a vacuum-tube voltmeter. For maximum accuracy a few minutes should be allowed after the final adjust-

ment for the oscillator to stabilize. It should be noted that if the potentiometer is adjusted so that it provides insufficient plate voltage, the signal oscillator will not function and no peak will be obtained on the null indicator. The voltage across the measuring terminals, for a given potentiometer setting, may vary somewhat with frequency.

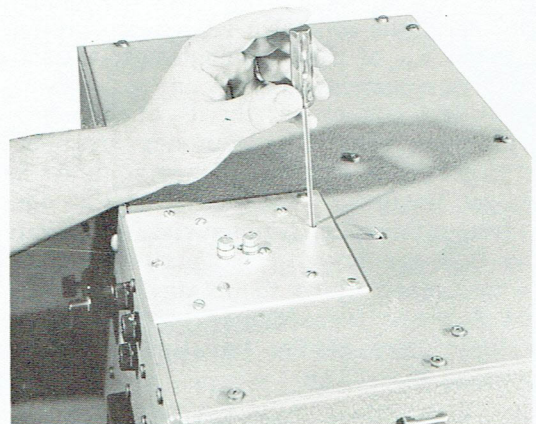

Figure 13 Adjustment of bridge trimmer

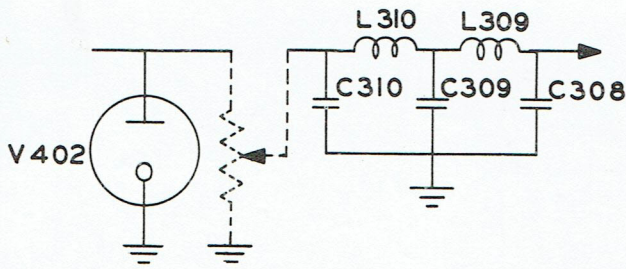

Figure 14 Terminal voltage reduction-circuit alteration

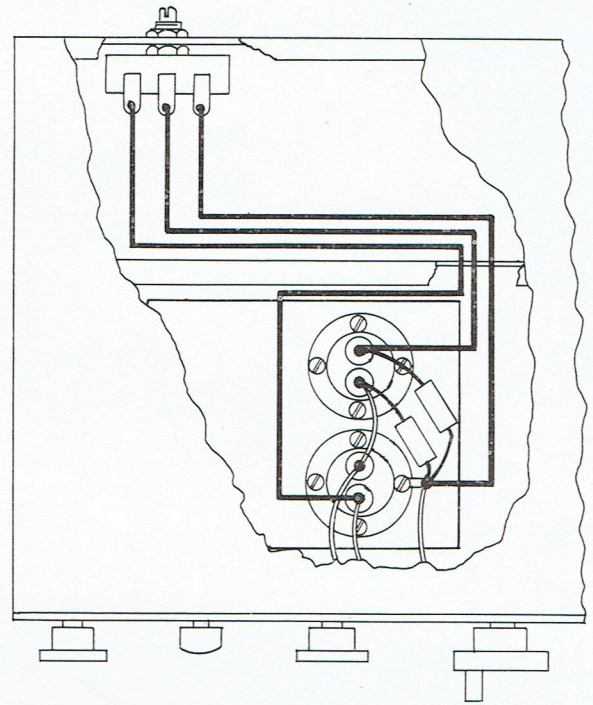

Figure 15 Diagram of circuit alteration

APPENDIX A

Extension of Ranges

1. LOW RESISTANCE

In dealing with low Q devices it is sometimes desirable to be able to measure resistance values below 15 ohms which is the lower limit of the direct-reading R_p scale.

At higher frequencies (in the neighborhood of 200 mc and above) the residual inductance of most components having series resistance values below 15 Ω such as low-value resistors, may be sufficient to increase the equivalent parallel resistance value above 15 ohms so that it may be measured directly. If not, a small inductance (having negligible series resistance) connected in series with the unknown will be sufficient to increase the R_p of the combination to the range of direct measurement.

At lower frequencies, the R_p of the unknown may be effectively increased for measurement by adding in series a small auxiliary resistor having a value preferably between 15 and 25 ohms. The series combination is measured and the values R_{p1} and C_{p1} are noted. The auxiliary resistor is then measured alone to obtain R_{p2} and C_{p2} . C_{p1} and X_{p2} are transformed to the equivalent series form (See Series-Parallel Conversion Chart, page, 32). Then

$$R_s = R_{s1} - R_{s2}, \text{ and } L_s = L_{s1} - L_{s2}$$

EXAMPLE: Measure, at a frequency of 50 mc, a small resistor known to have a series resistance

less than 15 Ω . Connect an auxilliary resistor of 20 Ω in series with the unknown unit and measure the series combination. $R_{p1} = 35.4\Omega$, $C_{p1} = 38\mu\text{mf}$. Measuring the auxilliary resistor alone, $R_{p2} = 22.2\Omega$, $C_{p2} = 47\mu\text{mf}$. Then $X_{p1} = 100\Omega$, and $X_{p2} = 68\Omega$. Converting to series form, $R_{s1} = 30\Omega$, $X_{s1} = 12.5\Omega$ and $R_{s2} = 20\Omega$, $X_{s2} = 6.3\Omega$. Then the unknown resistance $R_s = R_{s1} - R_{s2} = 10\Omega$. Its inductance $L_s = L_{s1} - L_{s2} = 0.04 - 0.02 = 0.02\mu\text{h}$.

At frequencies where practical line lengths may be used an alternative method is made possible by the impedance transforming effect produced by a quarter wave length of coaxial line. To use this method a resonant connecting line exactly one quarter-wave in length must first be established by cutting a section to approximately the correct length, attaching one end directly to the RX Meter binding post, and, with the far end shorted, adjusting the length (or frequency) in small increments until the C_p dial indicates "O" at balance. The unknown impedance is then connected across the far end of the cable and the bridge rebalanced. The results should then be converted to series form from which, by calculation or by use of the Smith Chart, the correct value of resistance may be derived.

2. LOW INDUCTANCE

Inductance values which require more than 100 μmf of resonating capacitance at a given frequency may be measured on the RX Meter by con-

necting an auxiliary resistor in series with the inductance. The additional resistance serves to reduce the overall Q and, correspondingly, the required resonating capacitance (C_p) in accordance with the relation,

$$L_s = \frac{C_p R_p^2}{1 + Q^2}$$

The value of the auxiliary resistor used depends on the appropriate value of the inductance to be measured, and may be selected from the table below.

Inductance Range	Resistor
10 μ h - 100 μ h	1000 Ω
1 μ h - 10 μ h	316 Ω
0.1 μ h - 1 μ h	100 Ω
0.001 μ h - 0.1 μ h	31.6 Ω

The value and accuracy of the auxiliary resistor is not critical and need only be of the correct order. The following procedure is suggested for such measurements:

a. Connect the unknown inductance in series with the auxiliary resistor across the RX Meter binding post. Using a minimum length of heavy, conducting strap, short the terminals of the inductance to remove it temporarily from the circuit.

b. Balance the bridge circuit and note the values of C_{p1} obtained for the series resistor alone.

c. Remove the shorting strap from the inductive component, restoring the latter to the circuit, and rebalance the bridge. Note the values of R_{p2} and C_{p2} for the series combination. Then the unknown inductance is obtained by $L_s = \Delta C (R_{p2})^2$ where $\Delta C = C_{p1} - C_{p2}$.

It should be noted that the inductance is shorted out, rather than removed, to avoid alteration of the physical configuration of the components which might otherwise affect the results. In dealing with extremely small inductance values, the inductance of the shorting strap itself will become significant and must be considered in interpreting the results.

3. HIGH CAPACITANCE

The range of capacitance measurement (0-20 mmf) may be increased to a maximum of 120 mmf by the use of an auxiliary coil, placed across the measuring terminals. This coil should be selected to resonate with the desired maximum capacitance at the measuring frequency. (Thus, if it is desired to measure capacities up to 100 mmf at a frequency of 1 mc, a coil of approximately 250 μ h should be used.) After the initial balance of the bridge connect the coil alone to the measuring circuit. Rebalance the bridge, using the R_p and C_p controls. The C_p dial reading should be recorded as C_{p1} . The R_p reading may be disregarded. With the coil in place, the unknown capacitance is then connected across the terminals and the bridge re-balanced to obtain C_{p2} . If the C_p dial reads in the white (negative) portion, the unknown capacitance, $C_p = C_{p1} - C_{p2}$. If the reading is in the yellow (positive) portion, $C_p = C_{p1} + C_{p2}$.

This method has certain restrictions which are imposed by the residual inductance of the RX meter binding posts. These may be summarized as follows:

1. Auxiliary coils having less than 0.1 μ h inductance should not be used.
2. If it is necessary to use a coil of less than 0.6 μ h, it must have a reactance within 20% of the capacitive reactance being measured, and the following correction must be applied to the RX meter reading;

$$\text{true capacity} = \Delta C \left(1 + \frac{0.003}{L} \right)$$

where ΔC = difference reading when unknown capacitance is connected

L = auxiliary inductance in μ h.

3. The auxiliary coil and unknown capacitor leads must be connected together at the binding posts to avoid increasing the effective binding post inductance.

APPENDIX B

Installation and Use of Co-ax Adapter Type 515-A

The Co-ax Adapter Kit Type 515-A is designed to permit connection to the RX Meter measuring circuit of any coaxial transmission line or fixture fitted with a Type "N" male connector. This makes available a convenient means of performing impedance measurements at a position remote from the RX Meter terminals, of utilizing the transforming properties of quarter- and half-wave lines for certain measurements, or of measuring the characteristics of the transmission line itself.

The kit includes a standard 50-ohm termination, combined with a type "N" male connector, which may be mounted on the adapter to permit

balancing of the RX Meter bridge circuit.

1. SPECIFICATIONS

a. Adapter

- 1) Connector: Type "N", female.
- 2) Characteristic impedance: 50 ohms
- 3) Finish: Silver plate with rhodium flash

b. Termination

- 1) Connector: Type "N", male.
- 2) Characteristic impedance: 50 ohms
- 3) DC resistance: 50 ohms, $\pm 1\%$
- 4) Maximum parallel capacitance (mounted on adapter): ± 0.2 mmf

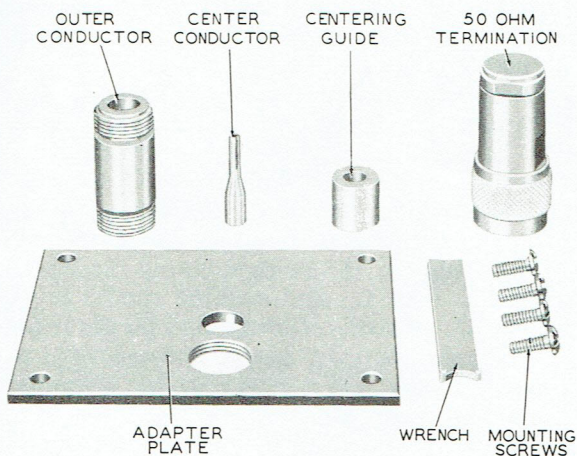

Figure B-1 515 Adapter Kit

- 5) VSWR: less than 1.10 up to 800 mc.
- 6) Maximum power: 1/2 watt.

2. EQUIPMENT SUPPLIED

- 1 Mounting plate
- 1 Outer conductor
- 1 Center conductor
- 1 Centering sleeve
- 1 50-ohm termination (516-A)
- 4 Mounting screws (6-32 x 3/8 BH)
- 1 Pin spanner wrench
- 1 Installation instruction sheet

3. INSTALLATION PROCEDURE

a. Preparation

- 1) Unscrew the knurled clamping nuts from both RX Meter binding posts

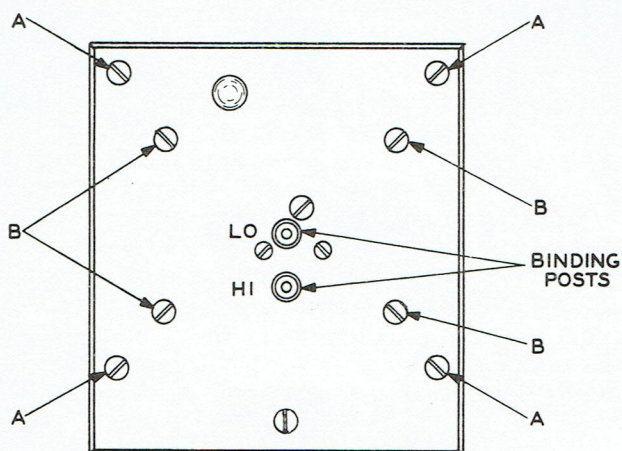

Figure B-2 RX Meter terminal plate—plan view

and, using the pin spanner wrench supplied, remove the base nut from the rear post.

- 2) Remove and put aside the four screws marked B in Figure B 2.
- 3) Clean the surface of the metal terminal plate with carbon tetrachloride to remove grease and dirt to insure good contact with the adapter mounting plate.

CAUTION: No other item should be loosened or removed.

b. Installation

- 1) Place the adapter mounting plate in position on the terminal plate of the instrument, with the beveled edges up, so that the large threaded hole clears the HI terminal.
- 2) Install the four screws provided with the kit in the corner holes of the adapter mounting plate. Do not tighten.
- 3) Replace the LO binding post base nut turning it in by hand and making sure that it enters the hole in the adapter plate. Do not tighten.
- 4) Position the adapter plate by slipping the centering sleeve over the HI post and adjusting the plate carefully until the outer conductor, when placed over the sleeve, can be screwed into the threaded platehole. Once it is started, do not advance the outer conductor more than a turn or two, since it will bind if it projects beyond the lower side of the plate.
- 5) Now tighten the four mounting screws and the LO post base nut.
- 6) Remove the outer conductor and slip off the centering sleeve. Screw the tapered HI center conductor on the threaded HI post stud and turn down finger tight. Re-install the outer conductor, also finger tight. The adapter is now ready for use.

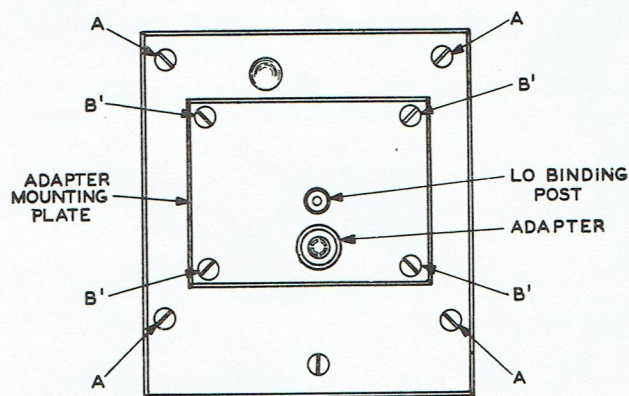

Figure B-3 Terminal plate with adapter installed—plan view

4. PRELIMINARY ADJUSTMENT of RX METER WITH ADAPTER INSTALLED

- a. After selecting the desired frequency, short out the adapter and adjust the detector tuning control for peak meter response.
- b. Remove the short from the adapter, set the R_p dial to ∞ , and balance the bridge by means of the ZERO BALANCE "R" control and the C_p control.
- c. Mount the 50-ohm termination on the adapter and, with the C_p dial set to zero, balance the bridge by means of the ZERO BALANCE "C" control and the R_p control. The R_p dial should read 50 ohms, ± 1.5 ohms, the tolerance being that of the bridge and resistor. Since the reactance has now been balanced out at 50 ohms and the resistance balanced at infinity, the instrument is ready for use and the termination may be removed

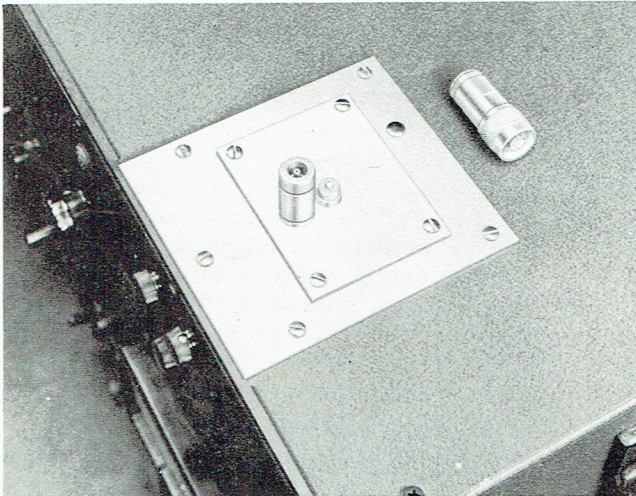

Figure B-4 515 Adapter installed

5. APPLICATION

a. Remote measurements

Under certain conditions it may be inconvenient or undesirable to position the component or circuit to be measured directly at the RX Meter terminals. In such cases measurements may be made at a distance of several feet or more by means of an interconnecting length of low-loss coaxial cable. In order to provide maximum accuracy and convenience of measurement the cable used should be a resonant section one-half wavelength (or an integral multiple thereof) long when sufficiently high frequencies are being used to make the cable length practical and the loss sufficiently low. Since a $1/2 \lambda$ transmission line is, effectively, a 1:1 impedance transformer, an impedance connected to one end will be reflected

almost identically at the other regardless of the characteristics of the line itself. If such a line is connected between the RX Meter terminals and an unknown impedance, the impedance may (with one minor correction) be regarded as being connected directly to one corner of the bridge itself.

The cable may be connected to the RX Meter either by tying the shield and center conductor directly to the terminals or, more conveniently, by means of a type "N" connector and the Coax Adapter Type 515-A described in Section B, page 19. The resonant $1/2 \lambda$ length may be obtained by measuring and cutting the cable to roughly the correct dimensions, attaching it to the adapter, and adjusting either the cable length (an adjustable air line is convenient in this application) or the frequency until the RX Meter indicates zero reactance at balance. If an adjustable line is not used, it is usually found most practical to adjust the frequency. This should be done in small increments, and care should be taken to retune the DETECTOR TUNING control after each frequency change. When the C_p dial reads zero at balance, the correct length has been obtained. It should be noted, however, that for higher impedance measurements, cable losses may become significant and should be accounted for when accurate results are desired. These losses should be calculated by conventional methods.

When a half-wave resonant line is connected to the RX Meter, the effect of the 0.003 microhenry residual binding post inductance is no longer present. In addition, the possibility of slight inaccuracies caused by capacitive effects between the unknown component and the terminal plate is eliminated.

If necessary, random-length (rather than half-wavelength) cable sections may be used for remote measurements. In this case, only 50 Ω line should be used. The measurements obtained must be transformed by means of a Smith chart (or by calculation), and for this purpose the exact electrical length of the section must be known. In obtaining this length, allowance must be made for the fact that the RX Meter binding posts are not connected directly to the bridge circuit, but are separated from it by leads which are roughly equivalent to about 2 inches of 50-ohm line. Thus, to obtain the effective length of random-length section, the measurement must be made from the far end of the cable to a point roughly 2" below the terminal plate of the instrument. When the length of this virtual extension must be known more precisely, it may be determined by use of a rigid, adjustable 50 ohm air line. The line should be adjusted to $1/4 \lambda$ at the desired frequency (indicated by $C_p = 0$ at balance). The actual length of $1/4 \lambda$ may be computed from the relation, $\lambda = C/f$, where C is the velocity of light, and f is the measuring frequency.

uency. The virtual extension of the line, inside the instrument, is then equal to the difference between the computed $\lambda/4$ and the distance from the end of the line to the terminal plate of the instrument. This value should be added to the physical length of all cables connected to the RX Meter, in determining their effective electrical length.

b. Transmission line characteristics

The adapter may also be used for the purpose of connecting a coaxial line to the RX Meter for the measurement of its own characteristics, (see Section C, page 22) although direct connection of the cable elements to the binding posts is usually slightly more accurate where convenient. When the adapter is used, very accurate transmission line characteristic measurements may be made at the end of a $1/2 \lambda$ section, as described above.

6. NORMAL MEASUREMENTS WITH ADAPTER PLATE IN PLACE.

Measurements which do not require the use of the adapter may be made by merely unscrewing the outer and center conductors of the adapter and replacing the HI post clamping nut. The adapter mounting plate may be left in place. This plate adds a capacitance of 0.3 mmf to the bridge circuit, but under ordinary conditions this will not affect bridge balance because of the compensating capacitance available in the ZERO BALANCE "C" control. However, if it should be found impossible to effect preliminary bridge balance by means of this control, the C_p control may be used to provide the slight additional compensation necessary. The amount of this compensation (0.1, 0.2 or 0.3 mmf) should then be subtracted from all C_p readings.

APPENDIX C

Special Applications

1. COAXIAL TRANSMISSION LINE

The characteristic impedance, attenuation and velocity of propagation of relatively short sections of coaxial cable may be conveniently measured on the RX Meter.

In performing such measurements the cable may be connected either directly to the RX Meter binding posts, or at the end of a half-wavelength section of low-loss line, as described in Section B. If the cable is fitted with a type "N" male connector, it may be attached by means of the Co-ax Adapter Type 515-A.

The formulas used in the measuring procedures described below are approximations which are valid only when the cable to be measured has moderately low loss (i. e. $\omega L \gg R$, $\omega C \gg G$). When high-loss or delay lines are measured, the more general transmission line equations must be used.

a. Characteristic Impedance

The most satisfactory method of measuring characteristic impedance on the RX Meter is based on the familiar equation for a quarter-wave line--

$$Z_0 = \sqrt{Z_1 Z_2}$$

where Z_0 = characteristic impedance
 Z_1 = input impedance, with cable termination

and Z_2 = terminating impedance.

The procedure is relatively simple:

1. Select the desired measuring frequency on the RX Meter. Measure and cut a section of cable which is approximately $1/4$ wavelength long at this frequency.
2. Connect the cable to the RX Meter terminals (the inner conductor being connected to the HI post), and short the cable at the far end.
3. Balance the RX Meter, using the C_p and

R_p controls. If the cable length is correct a value of zero will be indicated on the C_p dial. If the latter reads in the yellow region (capacitive) the frequency should be lowered (or cable shortened); if it reads in the white region (inductive) the frequency should be raised slightly (or a longer piece of cable used). Since the Z_0 characteristic impedance will not change significantly with the frequency above 20 mc, it is usually more convenient to adjust the frequency. The R_p dial must be adjusted to obtain a null during the above measurements, but its reading may be disregarded.

4. Select a half-watt carbon resistor having a value approximately equal to the estimated characteristic impedance of the cable. If the latter cannot be estimated, use about 50 ohms. Unshort the far end of the quarter-wave section and connect the resistor across it, keeping the leads as short as possible. Balance the bridge and record R_p as R_1 .
5. Remove the resistor from the end of the cable and measure it directly on the bridge terminal with the cable disconnected, recording this value of R_p as R_2 .
6. The characteristic impedance of the cable is then $Z_0 = \sqrt{R_1 \times R_2} \Omega$.

EXAMPLE: It is desired to check the characteristic impedance of a length of RG-58/U cable. Arbitrarily selecting a frequency of 40 mc, set the RX Meter to this value. From Figure C1 it is determined that a $1/4 \lambda$ wavelength of polyethylene dielectric cable at this frequency is about 52" long. Cutting a section of cable to this length, dress back the ends about $1/2$ " to expose the cen-

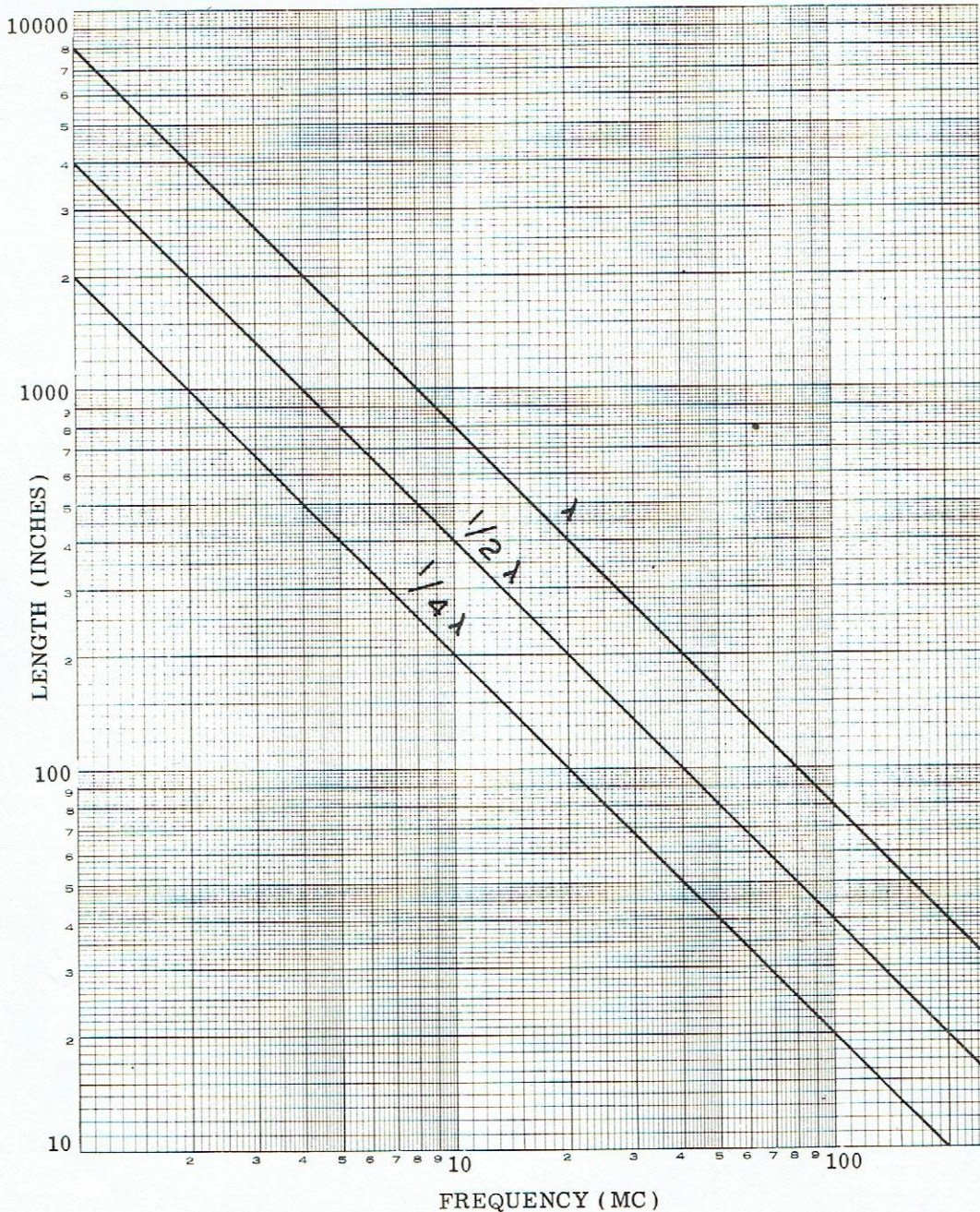

Figure C-1 Length-vs-frequency chart-polyethylene dielectric cable

ter conductor and shield. Initial balance of the RX Meter is obtained, and the cable is connected to the measuring terminals and shorted at the far end. Rebalancing the instrument, it is noted that the C_p dial reads in the capacitive region, indicating that the cable is too long. Assuming that it is easier to reduce the frequency than to cut the cable, this is done in small steps adjusting the DETECTOR TUNING control after each step, and if necessary rebalancing the bridge (should not be necessary for small steps) until C_p is found to be essentially zero. A half-watt carbon resistor of

about 50Ω is connected in place of the short at the far end of the cable. With the bridge balanced, R_p is found to be 63.8Ω . This is recorded as R_1 . The resistor, removed from the cable and measured directly, has an R_p of 47Ω , which is recorded as R_2 . Then

$$Z_0 = \sqrt{R_1 R_2} = \sqrt{47 \times 63.8} = 54.75 \Omega.$$

b. Attenuation

In measuring attenuation a half-wave section of the unknown cable is used. If the frequency is such, however, that a half wavelength is less

than approximately four feet, a one wavelength or three-halves wavelength piece should be used, with no change in the following procedure. This serves to minimize the effect of irregularities in the cable, etc.

1. Set the RX meter to the desired measuring frequency and obtain initial balance of the instrument.
2. Cut a one-half wavelength section of the cable to be measured, and attach one end to the RX meter terminals, leaving the far end open-circuited.
3. Balance the bridge. If $C_p = 0$ the cable is the proper length and R_p should be recorded. If C_p does not equal 0 the cable length or frequency should be adjusted until the correct length is obtained. The attenuation may then be computed by means of the following approximation for $R_p \geq 5Z_0$:

$$db \approx \frac{Z_0 \times 8.69 \times 1200}{R_p \times \text{length in inches}}$$

where Z_0 = characteristic impedance

c. Velocity Factor

The velocity factor of a given section of cable may be determined from the relation

$$V = \frac{\text{physical length of } 1/2\lambda \text{ cable section}}{\text{length of } 1/2\lambda \text{ in air}}$$

2. BALANCED TRANSMISSION LINE

CHARACTERISTICS

Dual, or balanced, transmission lines, such as "twin lead", cannot be measured by direct connection to the RX Meter terminals, but must be attached through a "balun". The function of the balun is to supply an RF signal which is equal and opposite in phase to each conductor of the balanced line, while providing an equally high resistance path to ground for both elements. There are a number of forms which can be used, depending on the situation. Several commercial types are available if desired. Probably the simplest type of balun can be made by doubling a one half wavelength section of co-axial line and connecting the outer conductors at the ends. The

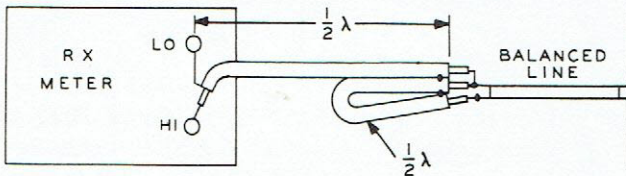

Figure C-2 Diagram of 1/2 wavelength balun

outer conductors are then connected to the RX Meter LO post, and one center conductor is connected to the HI post. The balanced line may then be connected to both center conductors. Figure C 2 illustrates such a balun connected at the end of a half wavelength resonant section which elimi-

nates the inductance effects of the instrument's binding post. Since this type of balun acts as a 2:1 voltage transformer, or a 4:1 impedance transformer, the factor 4 must be used in computing the desired characteristics from the measurements made.

a. Characteristic Impedance

1. Measure the balun open-circuited, on the RX Meter. If the length is correct, C_p should equal essentially 0. If not, readjust the frequency slightly until the length is correct. Record the R_p reading as R_1 .
2. Measure and cut a section of the balanced line to be measured slightly longer than one quarter λ and attach it to the balun with the far end shorted. Shorten the line gradually, by cutting off small pieces, until C_p once again is essentially 0. (Do not readjust frequency).
3. Connect a half-watt resistor of approximately 100Ω to the far end of the quarter-wave line and measure the R_p of the combination. Call this value R_2 .
4. Then the equivalent resistance (R_3) of the quarter-wave cable terminated by the resistor is given by,

$$R_3 = 4 \frac{(R_1 R_2)}{(R_1 - R_2)}$$

5. Measure the R_p of the resistor connected directly to the RX Meter terminal. Call this value R_4 .
6. Then

$$Z_0 = \sqrt{R_3 R_4}$$

b. Attenuation

1. Measure the balun open-circuited, on the RX meter, making sure that C_p is approximately equal to zero. Record R_p as R_1 .
2. Measure a half-wavelength section (or multiple thereof, to provide a minimum length of 4 feet), open-circuited at the far end, and record the result- R_p as R_2 . (Capacitance effects can be minimized by leading the balanced line vertically away from the bridge.)
3. Then the parallel resistance of the cable (R_3), as seen through the balun, is

$$R_3 = 4 \frac{(R_1 R_2)}{(R_1 - R_2)}$$

4. Attenuation is $db/100$ feet \approx

$$\frac{Z_0 \times 8.69 \times 1200}{R_3 \text{ length in cable in inches}}$$

c. Velocity of Propagation

The velocity of propagation of balanced line may be determined in the same manner as that described above for coaxial lines.

3. VACUUM TUBE INPUT IMPEDANCE

The dynamic input impedance of a vacuum tube is frequently an important parameter to the design engineer. The RX meter provides a convenient, accurate method of measuring the resistive and capacitive components of this impedance under actual operating conditions. A typical experimental circuit for the measurement of a triode is illustrated in Figure C3. In many

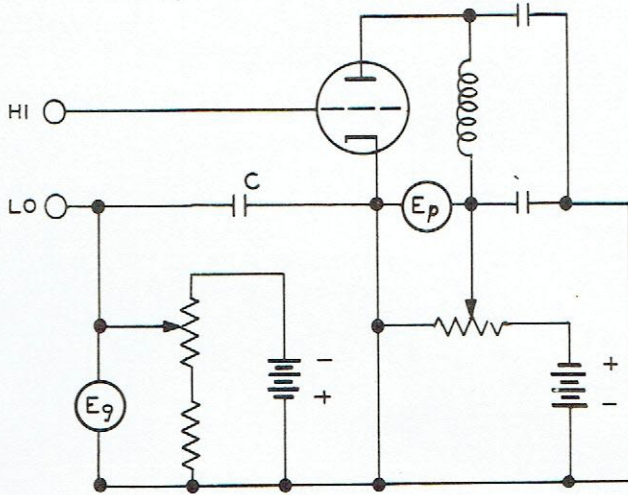

Figure C-3 Typical circuit for measuring vacuum tube input impedance on RX Meter

cases it will probably be found necessary to reduce the RF voltage at the RX Meter measuring terminals, by the method described in Section V, page 16.

Since the inductance and resistance of connecting leads will seriously affect the results, it is important that the tube socket be located directly at the RX meter binding post. If a number of measurements are to be made, it may be found practical to improvise a special jig for this purpose. If it is not possible to locate the socket in this manner, measurements may be made at the end of the half-wave coaxial line, as described in Section B, page 21.

4. MEASUREMENT of NON-LINEAR IMPEDANCE

Strictly speaking, the unqualified term "impedance of a non-linear component is not definitive. This is because the instantaneous average and RMS impedance of a non-linear component will vary with the following:

1. Level of applied dc voltage
2. Level of applied dc bias
3. Rectification, or axis shift, of the ac current

In dealing with non-linear elements such as

diodes, the impedance should be stated as "a small signal impedance at a specified value of direct current". In order to avoid differences in impedance caused by large variations in signal level, the applied signal should be kept below the value which increases the d. c. current present by 25%.

Non-linear impedances, such as diodes, may be measured satisfactorily on the RX Meter if certain precautions are taken in the measuring technique and in the interpretation of results.

When a non-linear element is placed across the RX Meter terminals, an intermodulation effect is observed which causes the values measured with the element connected in one position across the terminals to differ, to some extent, from the values measured with the element reversed. This is due to the fact that, through internal leakage, a small portion of the local oscillator signal appears across the measuring terminals. When the unknown impedance across the terminals is non-linear, this leakage signal beats with the main bridge signal at the IF frequency. This false IF signal is then coupled back to the modulator where it combines with the true signal from the bridge. A bridge unbalance (i. e. false balance) is then required to cancel the false signal. Reversing the non-linear element will reverse the false IF voltage and require a bridge unbalance in the opposite direction to obtain a null.

There are several possible corrections which may be made for this effect, depending on the difference observed in readings with reversal of the component, and on the accuracy desired.

If the two values which result from measuring the non-linear element in reversed positions are no more than 10% apart, the arithmetic average of the two values will be within 1% of the normal accuracy of the RX Meter. When the difference between the two values is of the order of 2:1, this averaging method will give results within $\pm 20\%$ of the normal accuracy of the RX Meter.

When the two readings differ by more than 10% and good accuracy is desired, the difference can usually be reduced by lowering the local oscillator voltage. This may be done by inserting a pad in the line from the local oscillator to the bridge. See Figure 12. (Signal Oscillator Output, J301, P101). In some cases, a 6db pad may be found necessary. Any type of attenuator may be used, as long as its impedance is of the order of 50 ohms.

Reducing the local oscillator signal may, in some cases, cause excessive reduction in sensitivity and an alternative method is required. In such cases, the local oscillator signal may be dispensed with entirely and replaced by a good communications receiver with an isolating RF stage, which may be used as the detector. This will prevent local oscillator voltage from leaking into the measuring circuit. To do this it is usually sufficient merely to disconnect the local oscillator cable. If further leakage is suspected,

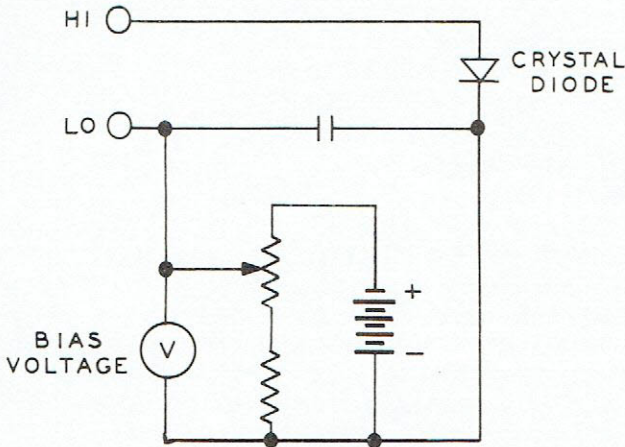

Figure C-4 Typical circuit for measuring crystal diodes on RX Meter

however, the local oscillator jack should be capped. The receiver should be connected to the jack at the right rear of the bridge chassis to which IF amplifier is normally connected. Co-axial cable should be used to connect the receiver, and care should be taken to shield the receiver input from the bridge terminals so that the receiver does not pickup voltage from them. Since no modulation is present on the signal oscillator, the receiver carrier level meter should be used as a null indicator. If an aural indication is desired, the BFO in the receiver may be used and a null of the beat note used as indication of balance. When measuring with the receiver as a detector no change of reading should be observed when the non-linear element is reversed, other than a normal change of capacitance due to a change in position. If the receiver is properly shielded, the balance will not be affected by placing a hand on the interconnecting cable or on the receiver cabinet. If this does affect the balance, the shielding should be improved.

c. Biased Non-Linear Elements

When a non-linear element is biased so as to produce an essentially linear response, no inter-modulation will occur and the element may be measured without correction for this effect. Biasing may be applied as shown in Figure C-6 and C-7.

5. USE AS HARMONIC ANALYSER

The RX Meter may be easily adapted for use in analyzing the harmonic content of RF signals. In this application the test signal is applied, through a simple coupling network, to the RX Meter measuring terminals. The internal signal oscillator is then tuned to successive harmonics of the test signal and the magnitude of each is indicated on the null indicator. The latter is

calibrated at the outset by means of a signal generator to provide direct indication of signal strength at the frequencies to be tested.

The following precautions should be observed in applying the RX meter in this manner:

a. The signal source should be matched to the input impedance of the RX meter terminals by means of the network illustrated below:

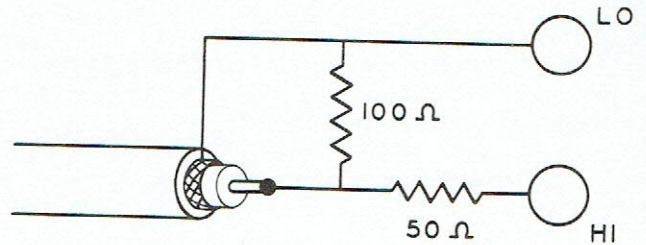

Figure C-5 Network for coupling external signal to RX Meter for harmonic analysis

b. The indicating meter calibration will vary with supply voltage. A regulated AC supply must be used.

c. Intuning for harmonics, care should be taken to tune for the input signal - not the internal signal.

6. METHOD OF APPLYING DC BIAS

When it is desired to apply DC bias to a component being measured, one of two general methods maybe used, depending on the amount of current to be passed through the component. If the current is less than 50 ma it may be passed directly through the RX meter measuring circuit (which presents a resistance of about 66Ω) without affecting the results, as indicated in Figure C6.In

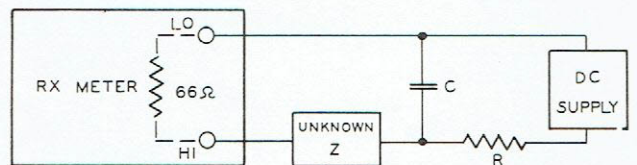

Figure C-6 Method of applying DC biasing current less than 50 ma.

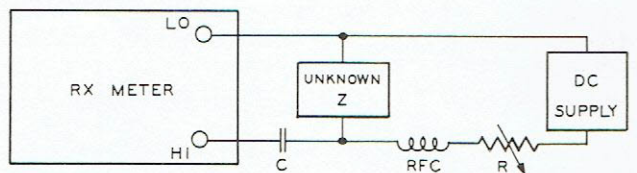

Figure C-7 Method of applying biasing current greater than 50 ma.

this circuit, R should be kept as large as possible to isolate the power supply, and C should be made large enough to present negligible reactance at the measuring frequency.

When the current is greater than 50 ma it cannot be applied to the RX meter terminals, and the alternative circuit of Fig. C 7 must be used. Here C must be large enough to offer negligible reactance at the measuring frequency while the reactance of the choke must be high. In this case, before connecting the component to be measured, the instrument should be balanced by means of the ZERO BALANCE controls with the DC supply circuit connected. If the zero balance controls have

insufficient range, obtain initial balance of the instrument with nothing connected; then measure the C_p and R_p of the DC supply circuit. Subsequent measurements of the unknown impedance can then be corrected for the effect of the DC supply circuit as follows:

$$C_p(\text{unknown}) = C_p(\text{unknown} + \text{DC supply}) - C_p(\text{DC supply})$$

$$R_p(\text{unknown}) = \frac{R_p(\text{DC supply}) \times R_p(\text{unknown} + \text{DC supply})}{R_p(\text{DC supply}) - R_p(\text{unknown} + \text{DC supply})}$$

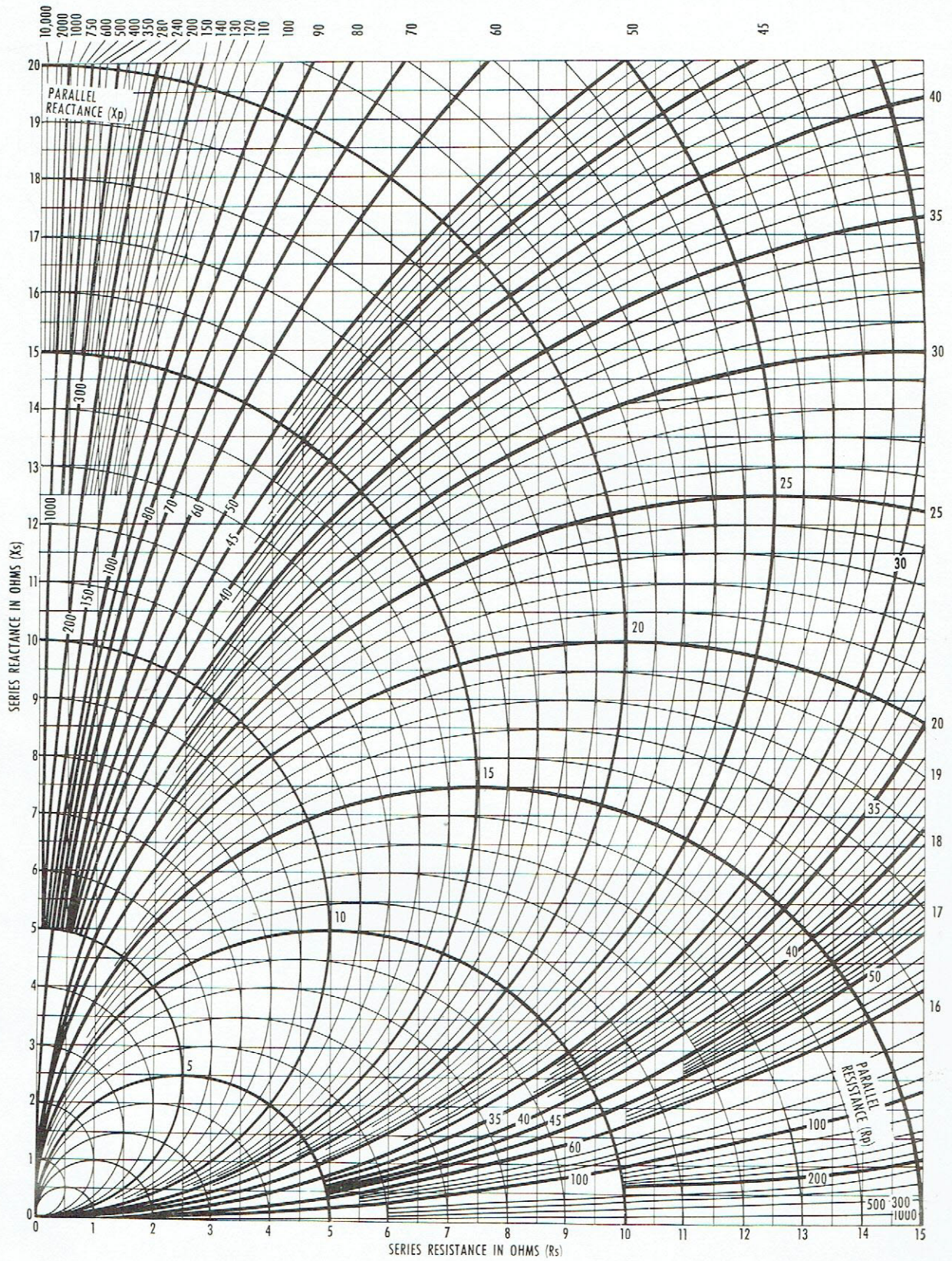

Series-Parallel Conversion Chart

SYMBOLS & ABBREVIATIONS

used in this manual

amp	ampere
c	velocity of light in free space
C	Capacitance
C_p	equivalent parallel resonant capacitance indicated by the RX Meter
db ^s	decibel
Δ	incremental difference
E	potential
I	current
IF	intermediate frequency (in the RX meter, the 100 KC output of the modulator)
kc	kilocycle
L	inductance
L_p	equivalent parallel inductance
L_s	equivalent series inductance
λ	wavelength
mc	megacycle
mh	millihenry
μf	microfarad (10^{-6} farads)
$\mu\mu f$	micromicrofarad (10^{-12} farads)
μh	microhenry (10^{-6} henry)
π	Pi (3.14)
R	Resistance
R_s	equivalent series resistance
R_p	equivalent parallel resistance indicated by the RX Meter
VHF	very high frequency
VSWR	voltage standing wave ratio
Z	impedance
Z_0	characteristic impedance
ω	$2\pi f$
Ω	ohms
f	frequency

ELECTRICAL COMPONENTS

BRIDGE UNIT

SYMBOL	BRC PART NO.	DESCRIPTION
R-101	80102	Resistor, fixed, film type, 127.5Ω, ±1/2%, 1/2 W
R-102	80119	Resistor, fixed, film type, 150Ω, ±1%, 1/2 W, hermetic seal
R-103	80304	Resistor, fixed, 4.7 KΩ, ±5%, 1 W
R-104	80641	Resistor, fixed, 4.7 MegΩ, ±5%, 1/2 W
R-105	80057	Resistor, fixed, 68Ω, ±5%, 1/2 W
R-106	80120	Resistor, fixed, film type, 182Ω, ±1%, 1/2 W
R-107	81016	Resistor, variable, composition, 100Ω, ±10%, 2 W <i>2100-0818</i>
R-108	80122	Resistor, fixed, film type, 470Ω, ±1%, 1/2 W
R-109	80188	Resistor, fixed, 220Ω, ±5%, 1/2 W
R-110	80203	Resistor, fixed, film type, 1.5 KΩ, ±1%, 1/2 W
R-111	80102	Resistor, fixed, film type, 127.5Ω, ±1/2%, 1/2 W
R-112	81017	Resistor, variable, composition, 500Ω, ±10%, 2 W <i>2100-0819</i>
C-101	84047	Capacitor, variable, pyrex tubular, .7-9 μmf
C-102	300856	Capacitor, fixed, .3 μmf - special
C-103	B301890	Capacitor, variable, 20 μmf - special
C-104	A301868(A)	Capacitor, variable, 2 μmf - special
C-105	A301868(B)	Capacitor, variable, 2 μmf - special
C-106	82428	Capacitor, fixed, ceramic, .01 μf
C-107	302001	Capacitor, variable, .5-5 μmf - special
C-108	302043	Capacitor, fixed, 20 μmf - special
C-109	300552	Capacitor, variable, 0-5 μmf
C-110	82428	Capacitor, fixed, ceramic, .01 μf
C-111	Cx Cond.	Capacitor, variable, 20-140 μmf - special
L-101	85591	Choke, RF, 10 μh
P-101	94156	Plug, UG 88/U
P-102	94156	Plug, UG 88/U
J-103	89065	Jack, UG 291/U
T-101	A302025	BRC Transformer
V-101	301637	Tube, 6AB4 <i>(Penible Unit) selected.</i>

AMPLIFIER

R-201	80170	Resistor, fixed, composition, 470Ω, ±5%, 1/2 W
R-202	80517	Resistor, fixed, composition, 100 KΩ, ±5%, 1/2 W
R-203	80057	Resistor, fixed, composition, 68Ω, ±5%, 1/2 W
R-204	80256	Resistor, fixed, composition, 2.2 KΩ, ±5%, 1/2 W
R-205	80460	Resistor, fixed, composition, 47 KΩ, ±5%, 1/2 W

AMPLIFIER (CONTINUED)

SYMBOL	BRC PART NO.	DESCRIPTION
R-206	80527	Resistor, fixed, composition, 150 K Ω , $\pm 5\%$, 1/2 W
R-207	80148	Resistor, fixed, composition, 1 K Ω , $\pm 5\%$, 1/2 W
R-208	80640	Resistor, fixed, composition, 470 K Ω , $\pm 5\%$, 1/2 W
R-209	80057	Resistor, fixed, composition, 68 Ω , $\pm 5\%$, 1/2 W
R-210	80256	Resistor, fixed, composition, 2.2 K Ω , $\pm 5\%$, 1/2 W
R-211	80273	Resistor, fixed, composition, 1.5 K Ω , $\pm 5\%$, 1/2 W
R-212	80527	Resistor, fixed, composition, 150 K Ω , $\pm 5\%$, 1/2 W
R-213	80148	Resistor, fixed, composition, 1 K Ω , $\pm 5\%$, 1/2 W
R-214	80148	Resistor, fixed, composition, 1 K Ω , $\pm 5\%$, 1/2 W
R-215	80361	Resistor, fixed, composition, 10 K Ω , $\pm 5\%$, 1/2 W
R-216	80230	Resistor, fixed, composition, 3 K Ω , $\pm 5\%$, 1/2 W
R-217	80138	Resistor, fixed, composition, 680 Ω , $\pm 5\%$, 1/2 W
C-201	82143	Capacitor, button mica, 100 μf , $\pm 10\%$
C-202	82321	Capacitor, mica, 3000 μf , $\pm 5\%$
C-203	82429	Capacitor, metalized paper, .05 μf , -20+30%, 400 V
C-204	82210	Capacitor, silver mica, 200 μf , $\pm 2\%$
C-205	82428	Capacitor, ceramic, .01 μf , +80-20%, 600 V
C-206	82429	Capacitor, metalized paper, .05 μf , -20+30%, 400 V
C-207	82429	Capacitor, metalized paper, .05 μf , -20+30%, 400 V
C-208	82202	Capacitor, mica, 150 μf , $\pm 5\%$, 500 V
C-209	82210	Capacitor, silver mica, 200 μf , $\pm 2\%$
C-210	82429	Capacitor, metalized paper, .05 μf , -20+30%, 400 V
C-211	82429	Capacitor, metalized paper, .05 μf , -20+20%, 400 V
C-212	82428	Capacitor, ceramic, .01 μf , +80-20%, 600 V
C-213	82210	Capacitor, silver mica, 200 μf , $\pm 2\%$
C-214	82210	Capacitor, silver mica, 200 μf , $\pm 2\%$
C-214	82210	Capacitor, silver mica, 200 μf , $\pm 2\%$
C-215	82102	Capacitor, mica, 30 μf , $\pm 5\%$, 500 V
C-216	82428	Capacitor, ceramic, .01 μf , +80-20%, 600 V
L-201	A301630	Interstage Coil
T-201	A301629	Input Transformer
T-202	A301631	Output Transformer
P-203	94156	Plug, UG 88/U
P-204	A301636	Plug, 7 Pin
V-201		Tube, 6AG5
V-202		Tube, 6AG5
CR-201	91081	Crystal, 1N34A
CR-202	91081	Crystal, 1N34A

OSCILLATOR

R-301	80170	Resistor, fixed, composition, 470 Ω , $\pm 5\%$, 1/2 W
R-302	80170	Resistor, fixed, composition, 470 Ω , $\pm 5\%$, 1/2 W
R-303	80170	Resistor, fixed, composition, 470 Ω , $\pm 5\%$, 1/2 W
R-304	80170	Resistor, fixed, composition, 470 Ω , $\pm 5\%$, 1/2 W
R-305	80170	Resistor, fixed, composition, 470 Ω , $\pm 5\%$, 1/2 W

OSCILLATOR (CONTINUED)

SYMBOL	BRC PART NO.	DESCRIPTION
R-306	80170	Resistor, fixed, composition, 470Ω, ±5%, 1/2 W
R-307	80170	Resistor, fixed, composition, 470Ω, ±5%, 1/2 W
R-308	80170	Resistor, fixed, composition, 470Ω, ±5%, 1/2 W
R-309	80472	Resistor, fixed, composition, 22 KΩ, ±5%, 1/2 W
R-310	80170	Resistor, fixed, composition, 470Ω, ±5%, 1/2 W
R-311	80170	Resistor, fixed, composition, 470Ω, ±5%, 1/2 W
R-312	80170	Resistor, fixed, composition, 470Ω, ±5%, 1/2 W
R-313	80170	Resistor, fixed, composition, 470Ω, ±5%, 1/2 W
R-314	80170	Resistor, fixed, composition, 470Ω, ±5%, 1/2 W
R-315	80170	Resistor, fixed, composition, 470Ω, ±5%, 1/2 W
R-316	80170	Resistor, fixed, composition, 470Ω, ±5%, 1/2 W
R-317	80170	Resistor, fixed, composition, 470Ω, ±5%, 1/2 W
R-318	80472	Resistor, fixed, composition, 22 KΩ, ±5%, 1/2 W
R-319	80041	Resistor, fixed, composition, 47Ω, ±5%, 1/2 W
R-320	80041	Resistor, fixed, composition, 47Ω, ±5%, 1/2 W
R-321	80047	Resistor, fixed, carbon film, 5Ω, ±1%, 1/4 W
C-301	84082	Capacitor, variable, plastic tubular, .7-3 μmf
C-302	84082	Capacitor, variable, plastic tubular, .7-3 μmf
C-303	84082	Capacitor, variable, plastic tubular, .7-3 μmf
C-304	84088	Capacitor, variable, pyrex tubular, .3-3 μmf
C-305	B301711	Condenser, variable, BRC
C-306	82011	Capacitor, ceramic, 10 μmf, ±2%, 500 V
C-307	82003	Capacitor, ceramic, 5 μmf, ±0.25 μmf, 500 V
C-308	82307	Capacitor, button mica, 1000 μmf, ±10%
C-309	82428	Capacitor, ceramic, .01 μf, -80-20%, 600 V
C-310	82018	Capacitor, button mica, 15 μmf, ±10%
C-311	82307	Capacitor, button mica, 1000 μmf, ±10%
C-312	82428	Capacitor, ceramic, .01 μf, -80-20%, 600 V
C-313	82018	Capacitor, button mica, 15 μmf, ±10%
C-314	83055	Capacitor, metalized paper, 2 μf, -30-20%, 200 V
C-315	83023	Capacitor, metalized paper, .25 μf, +30-20%, 200 V
C-316	82011	Capacitor, ceramic, 10 μmf, ±2%, 500 V
C-317	84082	Capacitor, variable, plastic tubular, .7-3 μmf
C-318	82002	Capacitor, ceramic, 2 μmf, ±2%
C-319	82007	Capacitor, ceramic, 5 μmf, ±10%, 500 V
C-320	A302708	Capacitor, variable, .5-12 μmf, BRC
C-321	B301710	Condenser, variable, BRC
C-322	82011	Capacitor, ceramic, 10 μmf, ±2%, 500 V
C-323	82003	Capacitor, ceramic, 5 μmf, ±0.25 μmf, 500 V
C-324	82307	Capacitor, button mica, 1000 μmf, 500 V
C-325	82428	Capacitor, ceramic, .01 μf, +80-20%, 600 V
C-326	82018	Capacitor, button mica, 15 μmf, ±10%
C-327	82307	Capacitor, button mica, 1000 μmf, ±10%
C-328	82428	Capacitor, ceramic, .01 μf, +80-20%, 600 V
C-329	82018	Capacitor, button mica, 15 μmf, ±10%
C-330	82011	Capacitor, ceramic, 10 μmf, ±2%, 500 V
C-331	83019	Capacitor, metalized paper, .01 μf, -30-20%, 200 V
C-332	84082	Capacitor, variable, plastic tubular, .7-3 μmf
C-333	84082	Capacitor, variable, plastic tubular, .7-3 μmf
C-334	82306	Capacitor, ceramic disc 1000 μmf, -80-20%, 600 V
C-335	82306	Capacitor, ceramic disc, 1000 μmf, -80-20%, 600 V
L-301	A302771	Coil, signal oscillator, 110-250 mc
L-302	A301760	Coil, signal oscillator, 50-110 mc
L-303	A301761	Coil, signal oscillator, 21-50 mc

OSCILLATOR CONTINUED

SYMBOL	BRC PART NO.	DESCRIPTION
L-304	A301762	Coil, signal oscillator, 9-21 mc
L-305	A302234	Coil, signal oscillator, 4-9 mc
L-306	A302233	Coil, signal oscillator, 2-4 mc
L-307	A301766	Coil, signal oscillator, 1-2 mc
L-308	A301768	Coil, signal oscillator, .5-1 mc
L-309	85592	Choke, RF, 50 μ h
L-310	85592	Choke, RF, 50 μ h
L-311	85591	Choke, RF, 10 μ h
L-312	85591	Choke, RF, 10 μ h
L-313	85592	Choke, RF, 50 μ h
L-314	85592	Choke, RF, 50 μ h
L-315	85591	Choke, RF, 10 μ h
L-316	85591	Choke, RF, 10 μ h
L-317	A302770	Coil, local oscillator, 110-250 mc
L-318	A302081	Coil, local oscillator, 50-110 mc
L-319	A302080	Coil, local oscillator, 21-50 mc
L-320	A302079	Coil, local oscillator, 9-21 mc
L-321	A301763	Coil, local oscillator, 4-9 mc
L-322	A301764	Coil, local oscillator, 2-4 mc
L-323	A301765	Coil, local oscillator, 1-2 mc
L-324	A301767	Coil, local oscillator, .5-1 mc
V-301, 302		Tube, 5718

POWER SUPPLY

R-401	80055	Resistor, fixed, WW, 120 Ω , $\pm 5\%$, 5 W
R-402	80375	Resistor, fixed, WW, 15 K Ω , $\pm 5\%$, 5 W
R-403	80300	Resistor, fixed, WW, 4 K Ω , $\pm 5\%$, 10 W
R-404	80226	Resistor, fixed, WW, 2.5 K Ω , $\pm 5\%$, 10 W
R-405	80202	Resistor, fixed, WW, 1.25 K Ω , $\pm 5\%$, 5 W
R-406	80042	Resistor, fixed, WW, 0.68 Ω , $\pm 5\%$, 1/2 W
R-407	80188	Resistor, fixed, composition, 220 Ω , $\pm 5\%$, 1/2 W
C-401(A)	83050	Capacitor, fixed, electrolytic, 10 μ f, 450 VDCW
C-401(B)	83050	Capacitor, fixed, electrolytic, 10 μ f, 450 VDCW
C-401(C)	83050	Capacitor, fixed, electrolytic, 10 μ f, 450 VDCW
L-401	301769	Choke, filter, 10 hy, 80 ma, 240 Ω
T-401	A85074	Transformer, power
J-404	301632	Socket, 7 pin
J-405	89067	Socket, 11 pin
V-401		Tube, 5Y3GT
V-402		Tube, OD3
V-402	91019	Tube, ballast resistor, 6H-6
P-505	94149	Plug, 11 pin
M-501	B301685	Meter, null indicator
I-501	90904	Lamp, 6.3 V
F-501	95030	Fuse 1 1/2 Amp.
S-501	88059	Switch, toggle, DPDT

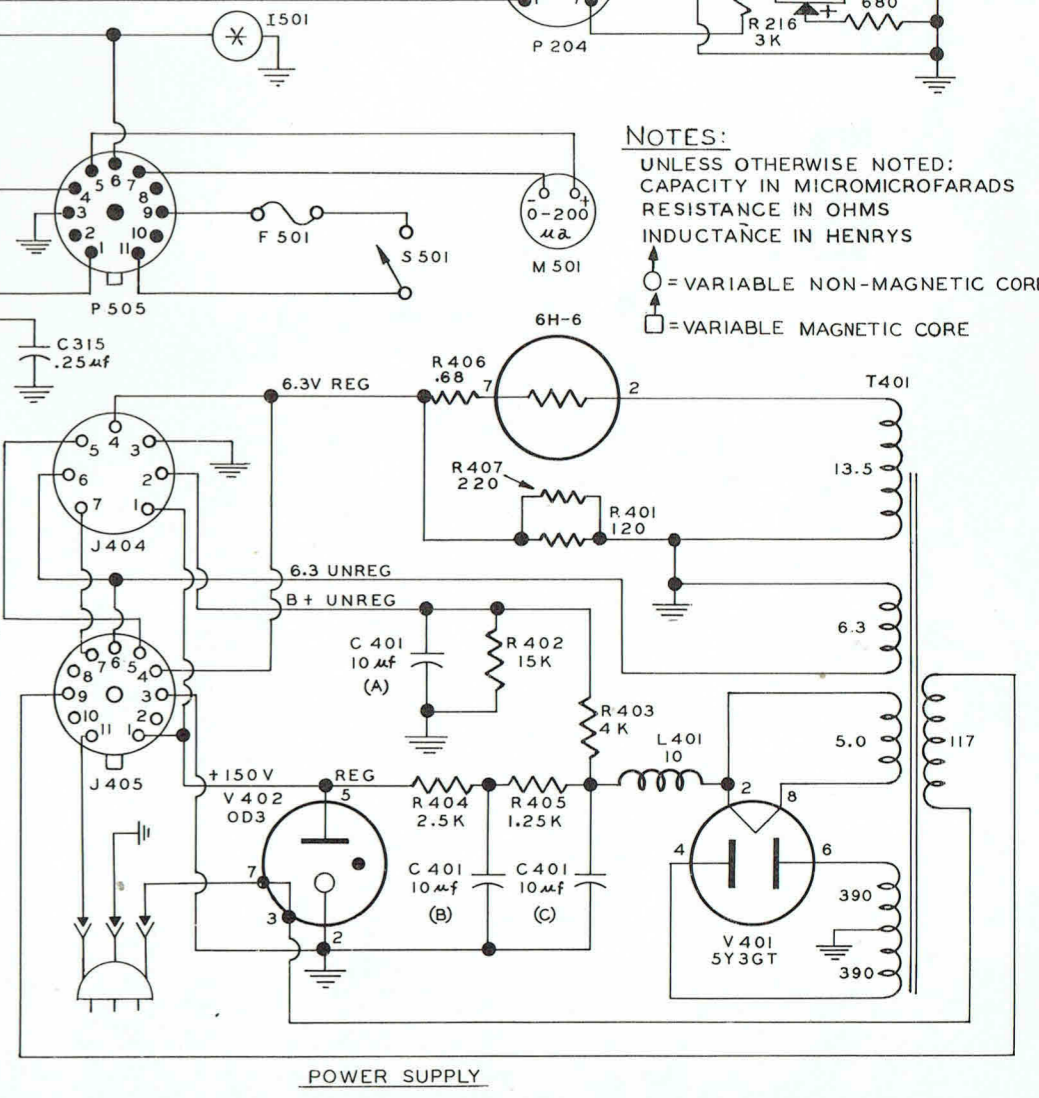
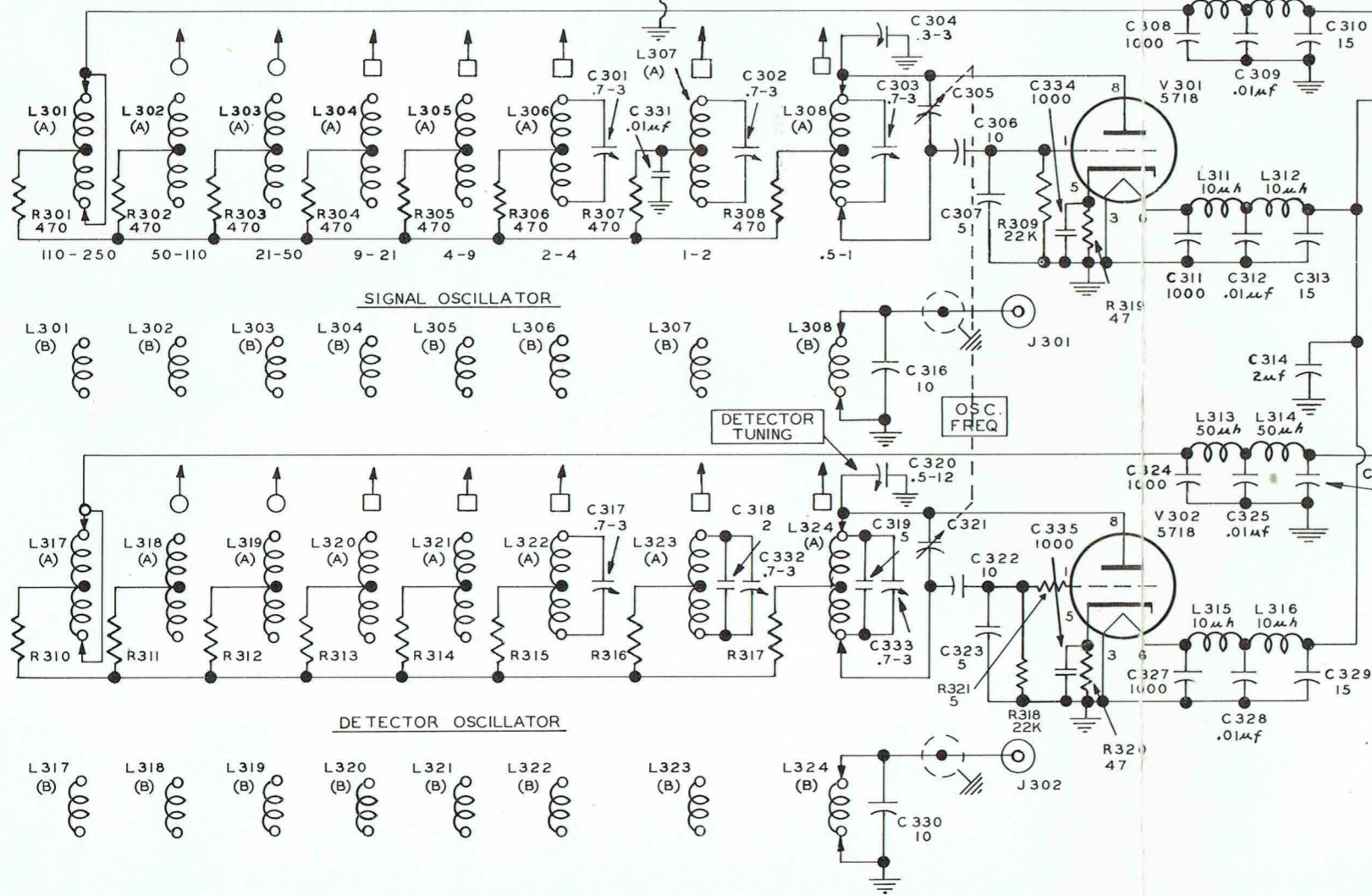
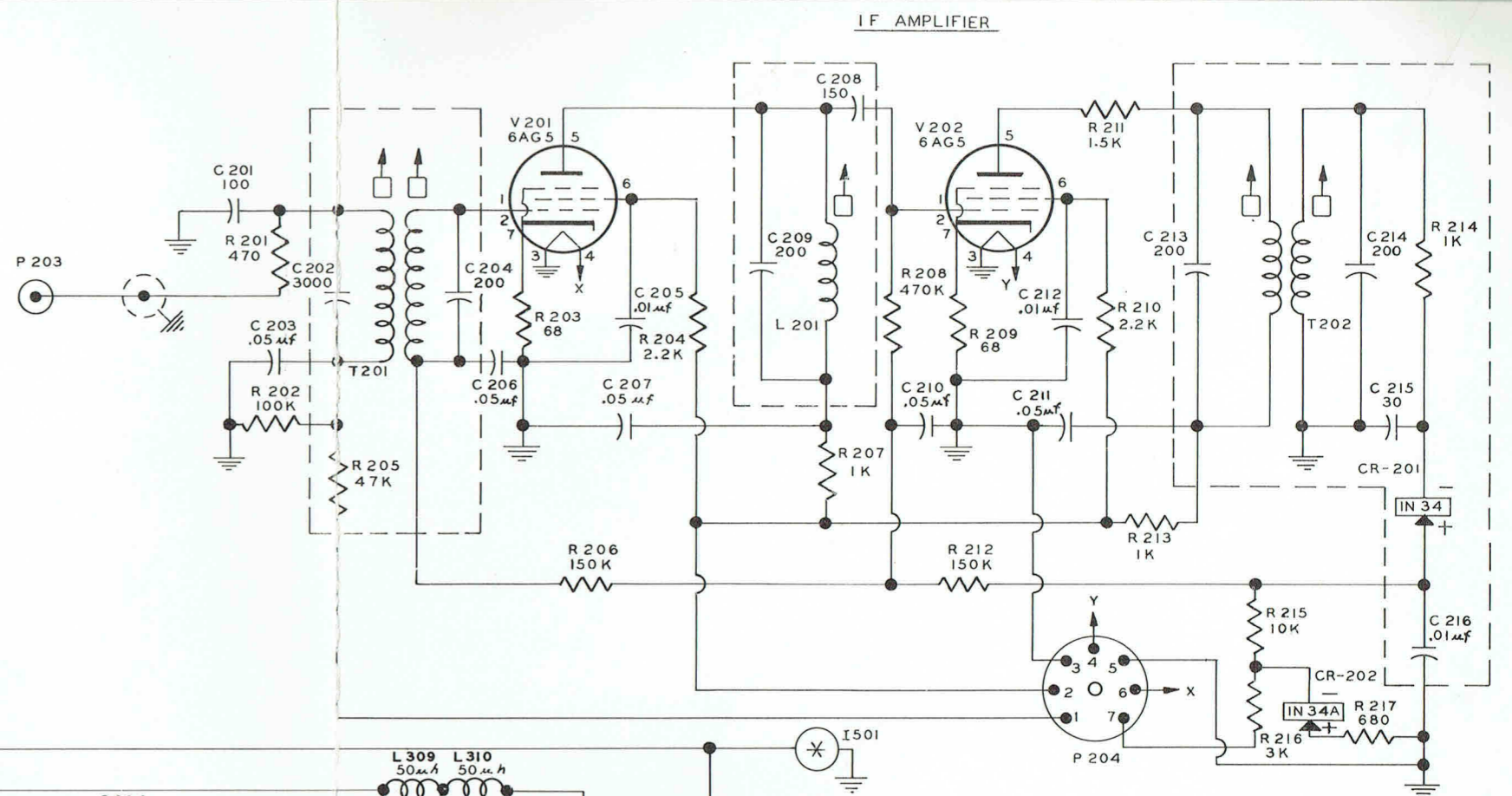
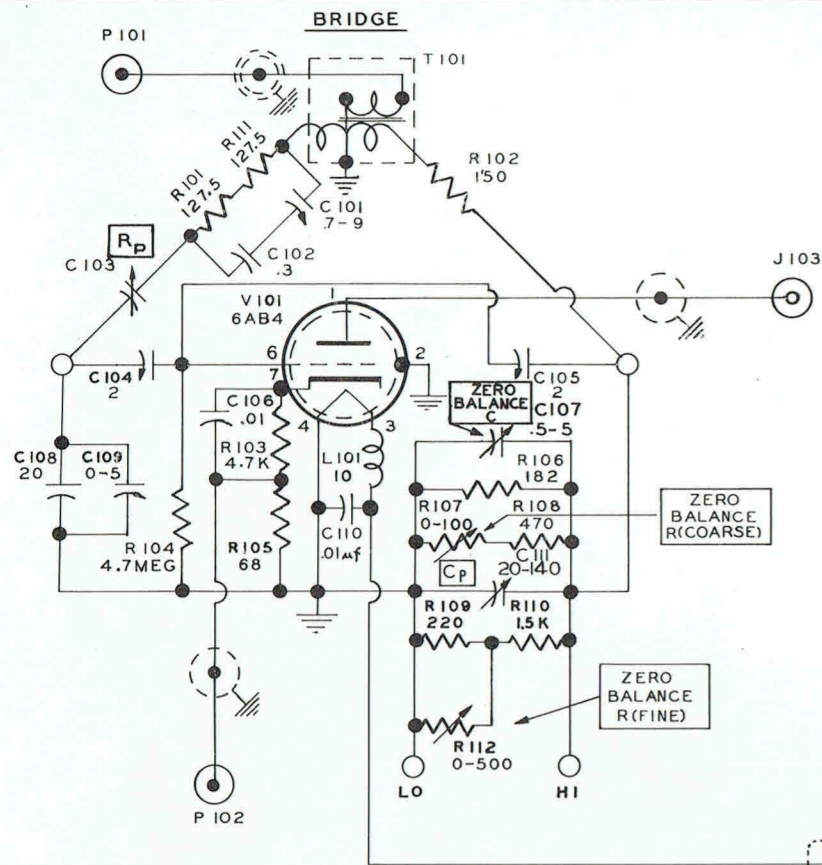

NOTES:
 UNLESS OTHERWISE NOTED:
 CAPACITY IN MICROMICROFARADS
 RESISTANCE IN OHMS
 INDUCTANCE IN HENRYS
 ○ = VARIABLE NON-MAGNETIC CORE
 □ = VARIABLE MAGNETIC CORE