

marantz.

model two fifty SERVICE MANUAL 250

Stereo Power Amplifier

TABLE OF CONTENTS

SECTION	PAGE
Introduction	1
Circuit Description	1
Meter Description	5
100, 220-Volt Conversion	5
Technical Specifications	6
Performance Verification	8
Trouble Analysis	11
Parts List	13
Component Layout Diagrams	15
Schematic	18

LIST OF ILLUSTRATIONS

FIGURE		PAGE
1.	Amplifier Simplified Schematic	2
2.	Rectifier/Relay Board Simplified Schematic	4
3.	250 Metering Circuit Simplified Schematic	4
4.	AC Power Control Box Simplified Schematic	10
5.	Amplifier Output Load Box Simplified Schematic	10
6.	Test Equipment Set-Up	12
7.	Power Amplifier Board Component Assembly Diagram	15
8.	Rectifier/Relay Board Component Assembly Diagram	16
9.	Meter Board Component Assembly Diagram	17
10.	Model 250 Schematic	18

TABLE		PAGE
1.	Test Equipment Required for Servicing	7

INTRODUCTION

This service manual is intended for use by authorized warranty stations. The manual contains service information for the Marantz Model 250 Stereo Power Amplifier, manufactured by the Marantz Company, a subsidiary of the Superscope Incorporated, Sun Valley, California 91352.

Adjustment, maintenance, and troubleshooting information listed herein should be attempted only by the experienced technician, one knowledgeable in solid state amplifier operation and the use of test equipment. All instructions should be read carefully and understood fully before proceeding with any service.

Symptoms (and their remedies) listed in the troubleshooting section, are those which might occur in some units. As the Marantz Company becomes aware of other field problems, supplementary service bulletins will be issued to all stations. To improve this service, all problems (and their solutions) not covered in this service manual should be brought to the attention of the National Service Manager at our Sun Valley location.

CIRCUIT DESCRIPTION

The following circuit description will be based on Channel A only. Channel B operates in an identical manner.

AMPLIFIER

The input stage of the power amplifier, fig. 1, is comprised of an emitter-follower, Q519, and its current source, Q518. The output of this stage is coupled through C502 and R506 to the differential amplifier (Q501, Q502), which drives an inverter (Q503) whose collector current is developed through current source Q504. The inverter is coupled to complementary pre-drivers (Q507, Q508). The output of the pre-drivers is applied to their respective drivers (Q510, Q511) which are coupled to their respective power transistors (Q802, Q804-Q803, Q805).

Output current regulation is accomplished through a current-sensing network. Excessive current levels are detected by resistors R531 and R532. Voltages developed across these resistors are applied to current sensors Q516 and Q517.

When excessive current levels are detected, Q516 and Q517 develop peak-limiting signals, which are applied to Q505 and Q506. These transistors disable the pre-drivers on excessive output current peaks, thus limiting peak output current to a safe level.

Feedback for the amplifier is developed at the junction of R531 and R532. The feedback is applied across two loops. Feedback applied across R520 and C509 completes the driver-power output loop. Feedback applied across R519 and C508 completes the loop for the entire power amplifier.

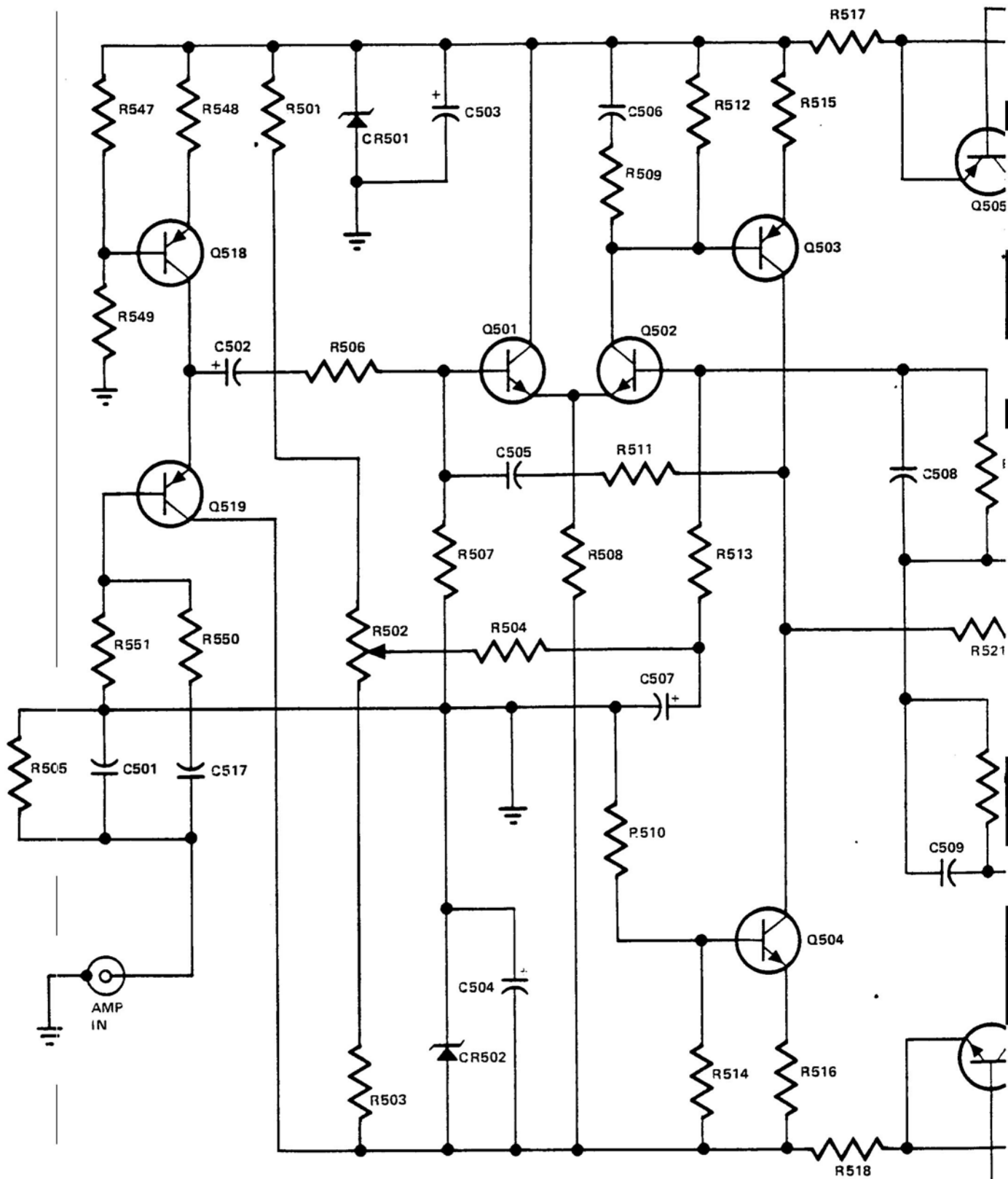
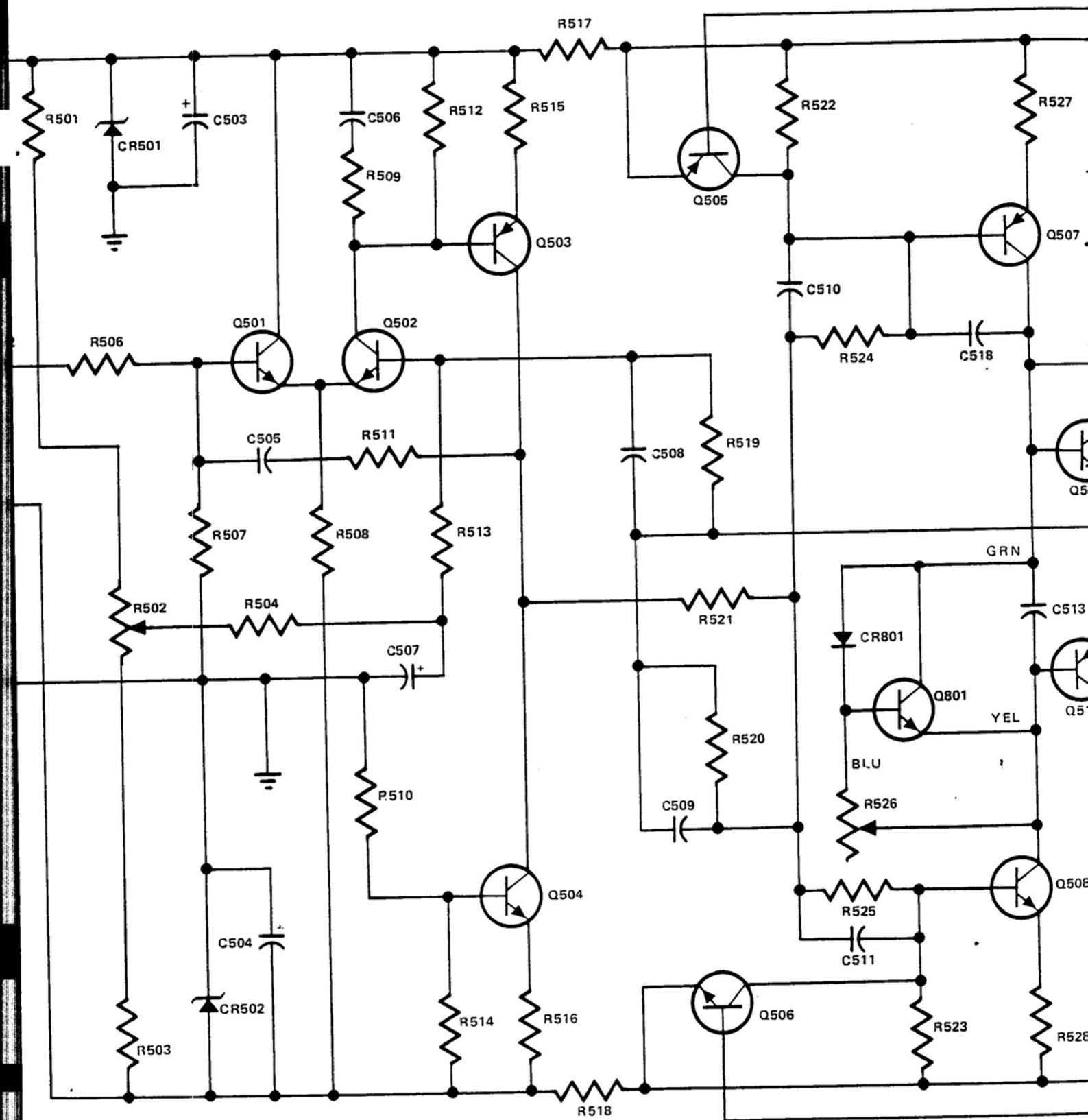
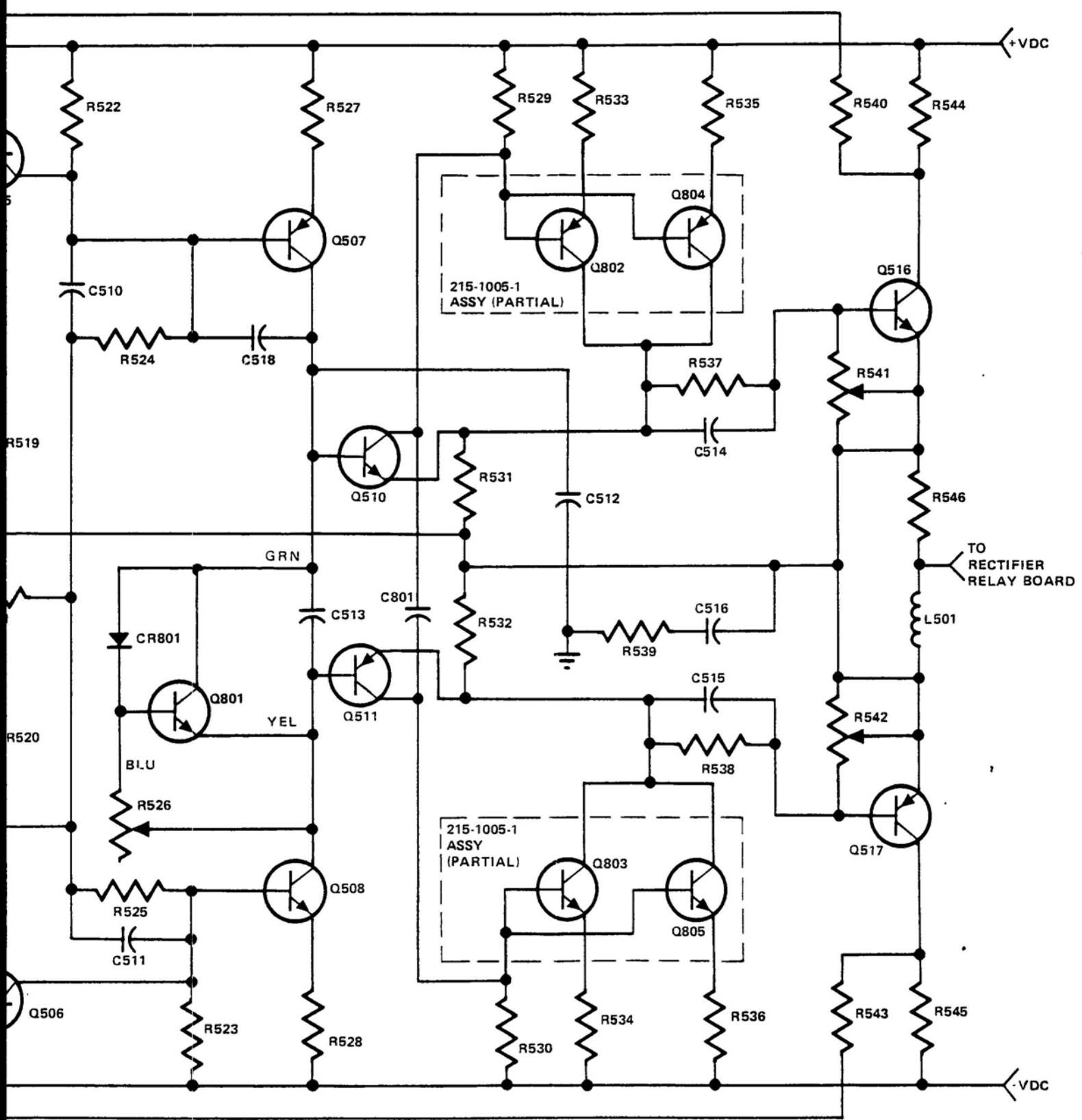

Figure 1. Amplifier Simplified Schematic



Schematic



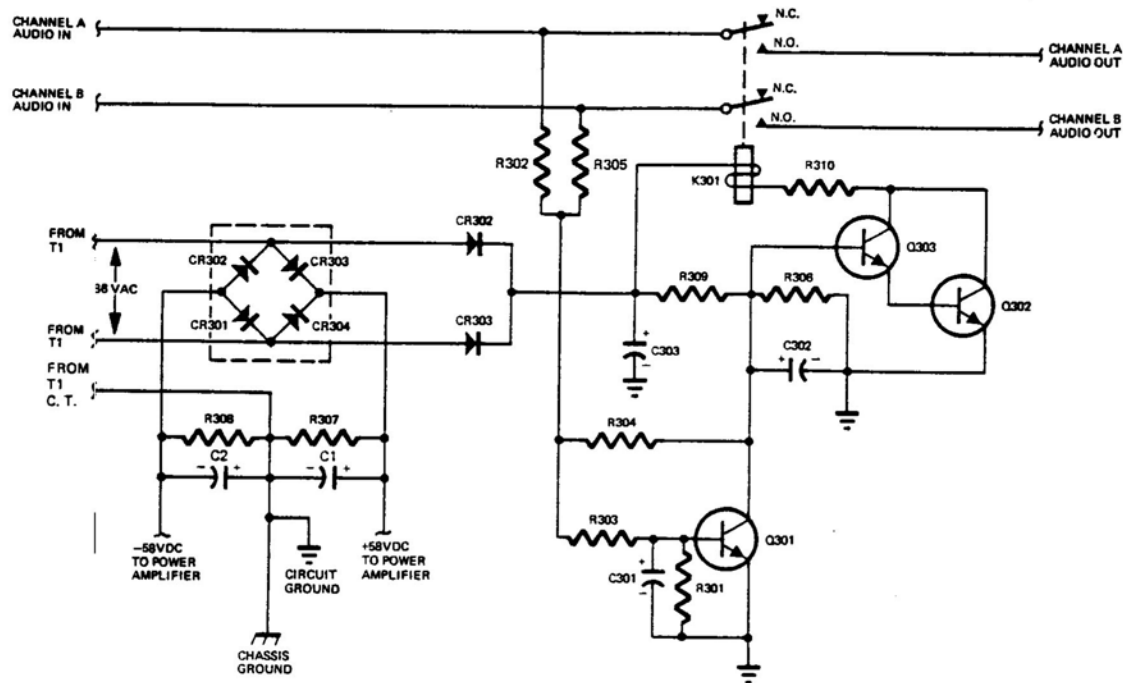

Figure 2. Rectifier/Relay Board Simplified Schematic

RECTIFIER-RELAY BOARD

The output of the power amplifier is applied to the wipers of relay K301 on the rectifier relay board, Figure 2. Relay K301 energizes after a minimum delay of two seconds after turn on. The length of the delay is a factor of the time constant of R306, R309, and C302. This delay at turn-on is to prevent any transient surges from reaching the output terminals. Additionally, resistors R302 and R305 sample the audio output signals. Should a constant DC level over +4.5 volts, or a high amplitude signal below 10 Hz be present, Q301 will turn on, shorting the base of Q303 to ground. C302 begins to discharge and K301 de-energizes. If a constant DC level over -4.5 volts is present, the voltage drop across R304 bucks the voltage present at the base of Q303 and K301 de-energizes. The output from K301 is applied to the SPEAKER TERMINALS.

Eighty six volts AC is applied to CR301 through CR304 which develop the +58 and -58 volts for the power amplifier board. CR305 and CR306 develop the positive voltage to energize K301.

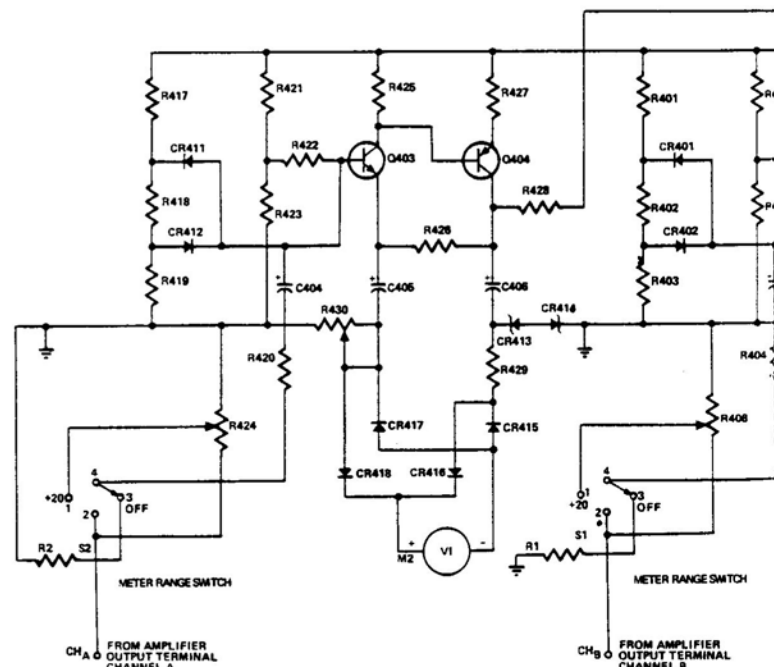
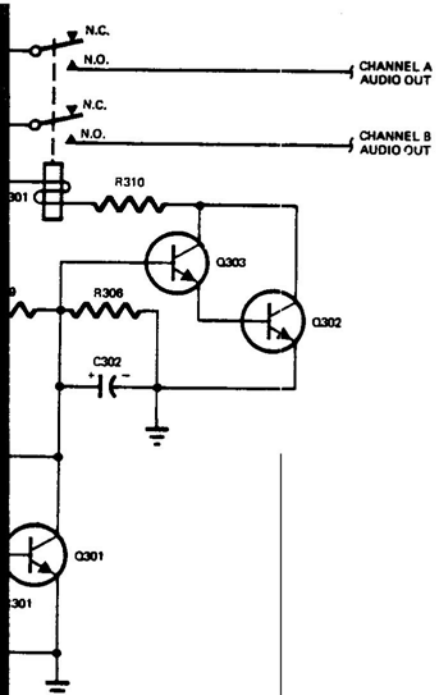

Figure 3. 250 Metering Circuit Simplified Diagram



METER DESCRIPTION

Audio from the amplifier output terminals is applied to METER RANGE switch S2, which selects as a reference two different power output levels: 0 dB = 0.75W or 0 dB = 75W.

Output from the range switch is applied to the input stage (Q403) of the meter drive amplifier.

Two diodes (CR411, CR412) limit excessive voltage spikes from reaching the input stage.

The output stage (Q404) drives a bridge rectifier circuit (CR415, CR416, CR417, CR418) which generates DC power for the VU meter (M2). Two zener diodes (CR413, CR414) connected back-to-back protect the meter and rectifier circuits from possible overload.

Overall amp
eter R430.
0 dB = 0.7
is in the 0 d

Meter caliB
METER RA
ing potenti
0 dB = 75W

DC feedback
by R426.

Zener diod
age for the

*NOTE:
8 Ω load.
8 Ω load.

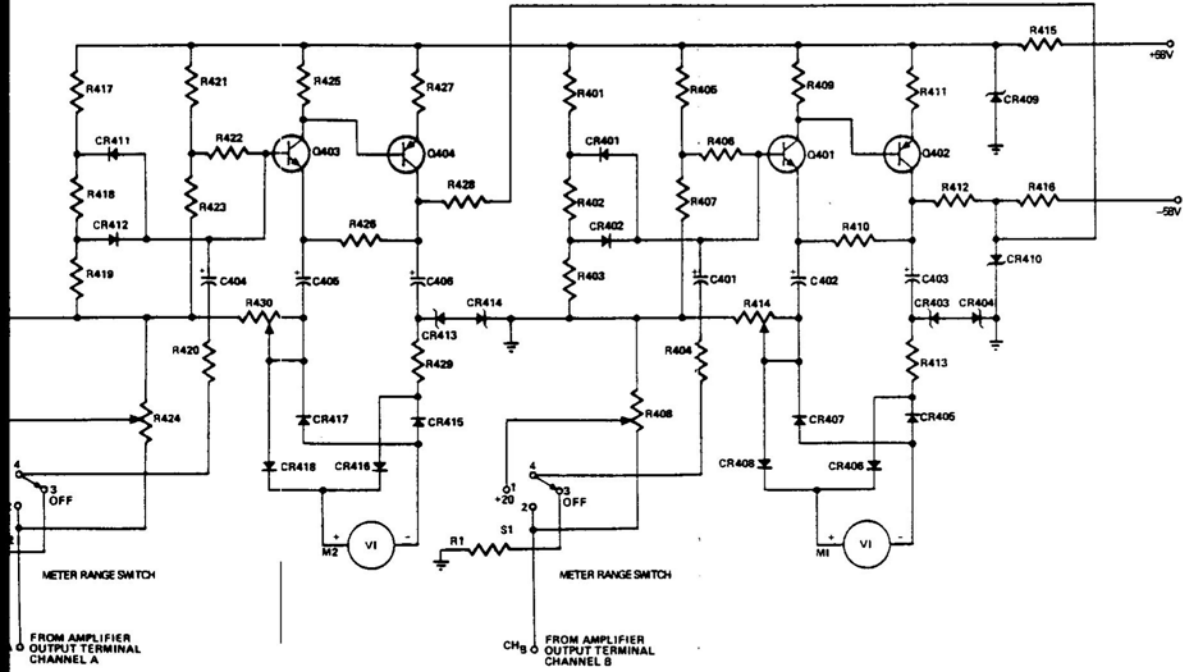

100,220 - V0

220-VOLT AC CONV

To convert the Mode
perform the following

1. Remove the top
2. Orient the Mode
facing toward the
3. Locate TB1, the
transformer half
which terminate
mary wires.
4. Unsolder the bla
wires and all jur

3. 250 Metering Circuit Simplified Diagram

METER DESCRIPTION

Audio from the amplifier output terminals is applied to METER RANGE switch S2, which selects as a reference two different power output levels: 0 dB = 0.75W or 0 dB = 75W.

Output from the range switch is applied to the input stage (Q403) of the meter drive amplifier.

Two diodes (CR411, CR412) limit excessive voltage spikes from reaching the input stage.

The output stage (Q404) drives a bridge rectifier circuit (CR415, CR416, CR417, CR418) which generates DC power for the VU meter (M2). Two zener diodes (CR413, CR414) connected back-to-back protect the meter and rectifier circuits from possible overload.

Overall amplifier gain is controlled by potentiometer R430. This adjustment calibrates the meter for 0 dB = 0.75W* when the METER RANGE switch is in the 0 dB position.

Meter calibration for the +20 dB position of the METER RANGE switch is accomplished by adjusting potentiometer R424 for a meter indication of 0 dB = 75W*.

DC feedback for the drive amplifier is accomplished by R426.

Zener diodes CR409, CR410 regulate supply voltage for the meter drive amplifier.

*NOTE: 0.75W corresponds to 2.45V across an 8Ω load. 75W corresponds to 24.5V across an 8Ω load.

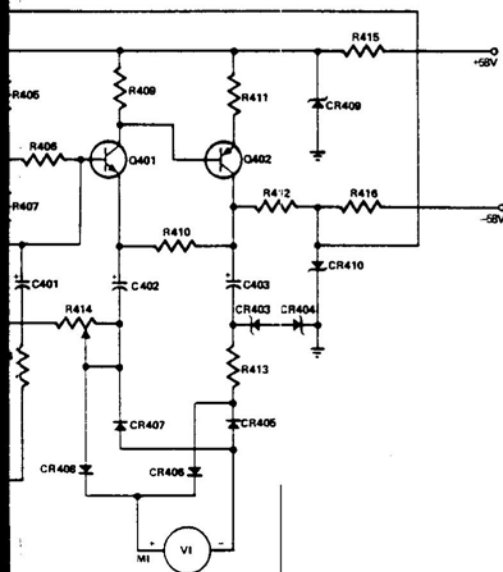

100,220-VOLT AC CONVERSION

220-VOLT AC CONVERSION

To convert the Model 250 to 220-volt operation, perform the following steps:

1. Remove the top cover.
2. Orient the Model 250 so that the rear panel is facing toward the viewer.
3. Locate TB1, the strip located on the power transformer half shell facing the rear panel, which terminates the power transformer primary wires.
4. Unsolder the black and white power lead-in wires and all jumpers from TB1.

TECHNICAL SPECIFICATIONS

Power Output (each channel, both channels driven, at rated distortion, 20 Hz to 20 KHz)

Load	RMS
4 ohms	150W
8 ohms	125W
16 ohms	64W

Total Harmonic Distortion	at or below rated power, 20 Hz to 20 KHz. less than 0.1%
Intermodulation Distortion	at or below rated power, SMPTE, any combination of two frequencies, 20 Hz to 20 KHz: less than 0.1%
Frequency Response	+0 - 1.5 dB 2 Hz to 100 KHz, ±0.1 dB 20 Hz to 20 KHz
Input Sensitivity	1.5 Volts for rated power
Input Impedance	100K ohms
Damping Factor	Greater than 100 at 8 ohms

GENERAL

Total Noise	Better than 106 dB below rated power into 8 ohms
Power Requirements	120V AC, 500W, 50/60 Hz
Dimensions	15-3/8" w. x 6-1/8" h. x 9-1/2" deep
Unit Weight	28 pounds
Shipping Weight	34 pounds
220 volt AC Conversion	

Split primary windings permit easy conversion from 120 volt to 220 volt operation.

100-VOLT AC CONVERSION

To convert the Model 250 to 100-volt operation, follow the procedure outlined for 220-volt conversion, except for items 5, 6, and 8. Item 8 is eliminated. These items will read:

5. Solder a jumper to TB1 connecting the grey and violet transformer wires.
6. Solder the black and white power lead-in wires to the brown and white transformer wires, respectively, on TB1.
7. Re-attach the top cover.
8. Replace the 6-amp, 250V fuse in the unit with the 4 amp, 250V fuse, Part # 451-1003, supplied with the 220-volt conversion kit, Part # 105-1005-1.
5. Solder two jumpers to TB1, one connecting the orange and violet transformer wires, and one connecting the grey and white transformer wires.
6. Solder the black and white power lead-in wires to the orange and white transformer wires, respectively, on TB1.

The Model 250 is now ready for 100-volt operation.

TEST EQUIPMENT REQUIRED FOR SERVICING

Table 1 lists the test equipment required for servicing the Model 250 Stereo Power Amplifier. The wattmeter, AC voltmeter, and variac may be assembled as a test fixture as shown schematically in Figure 3, and the load resistors and AC ammeter may be assembled into a second test fixture as shown in Figure 4.

Item	Manufacturer and Model No. (or equivalent)	Use
Distortion Analyzer	Hewlett Packard, Model 331A or 333A	Measures distortion and voltage of amplifier output.
Audio Oscillator	Weston Model CVO-100P (NOTE : Less than 0.02 percent residual distortion is required.)	Sinewave and squarewave signal source.
Oscilloscope	Tektronix, Model 503; Data, Model 555	Waveform analysis and troubleshooting
VTVM	RCA Senior Volt-Ohmyst, Model WV-98C	Voltage and resistance measurements.
AC Wattmeter	Simpson, Model 390	Monitors primary power consumption of amplifier.
AC Ammeter (0 to 10 amps)	Commercial Grade	Monitors amplifier output under short circuit condition.
Line Voltmeter (0 to 150 vac)	Commercial Grade	Monitors potential of primary power to amplifier.
Variable Autotransformer (0 to 140 vac, 10 amps)	Powerstat, Model 116B	Adjusts level of primary power to amplifier.
Shorting Plug	Use phono plug with 600 ohms across center pin and shell.	Shorts amplifier input to eliminate noise pickup.
Power Supply Bleeder Resistor (10 ohms at 1 W)	Commercial Grade	Discharges power supply filter capacitors prior to disassembly or resistance measurements.
Output Load Resistor ($8\ \Omega \pm 0.5\%$, 250 W)	Commercial Grade	Provides 8-ohm load for amplifier output termination.
Output Load Resistor ($4\ \Omega \pm 0.5\%$, 250 W)	Commercial Grade	Provides 4-ohm load for amplifier output termination.
Output Load Capacitor (0.5 mfd)	Mylar	Provides capacitive load for instability checks.
AC Power Control Box	Optional item. Fabricate in accordance with Figure 3.	Monitors and controls primary power for amplifier.
Amplifier Output Load Box	Optional item. Fabricate in accordance with Figure 4.	Provides various amplifier loads and can monitor shorted output.

PERFORMANCE VERIFICATION

TEST PROCEDURE

A. Test Equipment

Refer to Table 1 for required test equipment.

B. Preliminary Procedures

1. Set up the test equipment as shown in Figure 5, with the instrument controls set in the following positions:

Line Switch	Off
Variable-Line Switch	Variable
Watt Meter Switch	On
Variac	0 (Fully CCW)
Load – Resistive	Off
Load – Capacitive	Off
Scope Output	5V Range
Scope Gain	Minimum
AC Voltmeter	30V Range
Scope Vertical	20 mv/cm
Scope Horizontal, Line Sync	1 ms/cm
Scope Input	DC
Scope Trace (Input Shorted)	Centered

2. Connections, between the output terminals of the Model 250 and the resistive load, must have negligible resistance with respect to the resistance of the load itself. Applicable resistance adds to the total load, resulting in inaccurate measurement of output power.
3. Insert a shorting plug in each input jack of the Model 250.
4. Remove the top cover of the Model 250.

C. DC Balance Test

1. Connect oscilloscope to Channel A output terminals of the Model 250.
2. Turn Line Switch to ON and adjust variac to 120 vac.

3. After relay energizes, adjust Channel A (Left Hand Heatsink) amplifier board potentiometer R504 for an indication of a "line" zero (i.e., $0V \pm 50$ mv) as indicated on the oscilloscope.

4. Repeat test for Channel B (Right Hand Heatsink).

D. Total Hum and Noise Test

1. Connect the voltmeter across the Channel A output terminals of the Model 250.
2. With shorting plugs in the input jacks, the meter should read 0.25 mv or less.
3. Repeat test for Channel B.
4. Turn Line Switch to OFF and adjust variac to 0 (fully CCW).

E. Bias Adjustment Test

1. Preset the bias adjust potentiometer R526 on each amplifier board fully CCW.
2. After discharging the filter capacitors using a bleeder resistor, disconnect all red and blue wires from the capacitor terminals.
3. Turn Line Switch to ON and slowly advance variac while observing the voltmeter and wattmeter. The relay K301 should energize at 105 volts or less.
4. Turn Line Switch to OFF. Reconnect all red and blue wires to filter capacitors.
5. Turn Line Switch to ON and advance variac to 120 volts.
6. Observe wattmeter reading. Adjust the Channel A amplifier board potentiometer R526 to increase wattmeter reading to 10 watts above the initial reading.
7. Adjust the Channel B amplifier board potentiometer R536 to increase wattmeter reading to 10 watts above reading taken with left channel biased properly.
8. Turn the Line Switch to OFF. Remove shorting plugs from the input jacks.

NOTE: AC line voltage must be maintained at 120 volts at all times during remaining tests.

F. Maximum Power Output

1. Connect the audio oscillator to the input jacks of the Model 250. Set the audio oscillator frequency to 20 KHz.
2. Connect the distortion analyzer across the Channel A output load (4 ohms), set the analyzer on the 30 vac scale.
3. Turn the amplifier board potentiometers R541 and R542 fully CCW.
4. Turn Line Switch to ON. Turn the analyzer and audio generator to ON. Increase the audio oscillator output until the analyzer indicates 25.5 vac.
5. Adjust potentiometer R541 clockwise until the positive peak of the waveform, as observed on the oscilloscope, just begins to clip.
6. Adjust potentiometer R542 clockwise until the negative peak just begins to clip.
7. Change output load to 8 ohms. Set analyzer sequentially to 20 Hz, 2 KHz, and 20 KHz. Output voltage should not be less than 31.6 volts.
8. Turn Line Switch to OFF. Arrange setup for Channel B and repeat steps 4 through 7.

G. Relay Operation

1. Turn Line Switch to OFF. Wait approximately 2 minutes.
2. Turn Line Switch to ON. The elapsed time between the instant the power is applied until the relay energizes should be between two and ten seconds.
3. Set Audio Oscillator to 4 Hz with output reduced to minimum.
4. Increase Audio Oscillator output slowly, watching the voltmeter. The relay should de-energize between 15 and 32 volts.

H. Harmonic Distortion Test

1. Set Audio Oscillator frequency to 20 Hz and adjust level for 31.6V output. Set Distortion Analyzer to SET LEVEL – MANUAL mode. Adjust sensitivity for full scale reading on 0-1 scale.
2. Switch Distortion Analyzer to DISTORTION mode and monitor Channel A output. Total harmonic distortion should be no greater than 0.1%.
3. Repeat test for Channel A with Audio Oscillator frequency set at 20 KHz.
4. Repeat test for Channel A at 20 Hz and 20 KHz with 0.5 MFD across load. Total harmonic distortion should not exceed 0.15%. Verify absence of parasitic oscillation.
5. Perform steps 2, 3, and 4 for Channel B.

J. Short Circuit Test

CAUTION: Do not perform this test if amplifier shows any sign of parasitic oscillation.

1. With amplifier working into an 8 ohm load, set Audio Oscillator level to 22 volts at 200 Hz.
2. Short out each channel with Ammeter. Reading should not exceed 9.5 amperes.

K. Frequency Response Test

1. Using 8 ohm load and Audio Oscillator level at 30 volts, sweep frequency from 20 Hz through 20 KHz.
2. Output voltage should stay between 29.7 vac and 30.3 vac

L. Meter Calibration Procedure

1. Set the frequency of the audio oscillator to 1 KHz. Connect oscillator to CHANNEL A input jack. Connect analyzer to CHANNEL A output terminal.

2. Set the controls of the analyzer for voltage measurement on the 3-volt scale.
3. Set the METER RANGE switch to the 0 dB position.
4. Adjust the oscillator output level until the amplifier output measures 2.45 volts.
5. Observe CHANNEL A meter. The meter should indicate 0 dB. If the meter does not indicate 0 dB, adjust potentiometer R430 on the meter board for an 0 dB indication.
6. Set the controls of the analyzer for voltage measurement on the 30-volt scale.
7. Set the CHANNEL A METER RANGE to the +20 dB position.
8. Adjust the oscillator output level until the amplifier output measures 24.5 volts.
9. Observe Channel A dB meter. The meter should indicate 0 dB. If the meter does not indicate 0 dB, adjust potentiometer R424 for an 0 dB indication.
10. Perform steps 1-9 for Channel B. If calibration is necessary, use potentiometer R414 on the meter board in step 5, and potentiometer R408 in step 8.

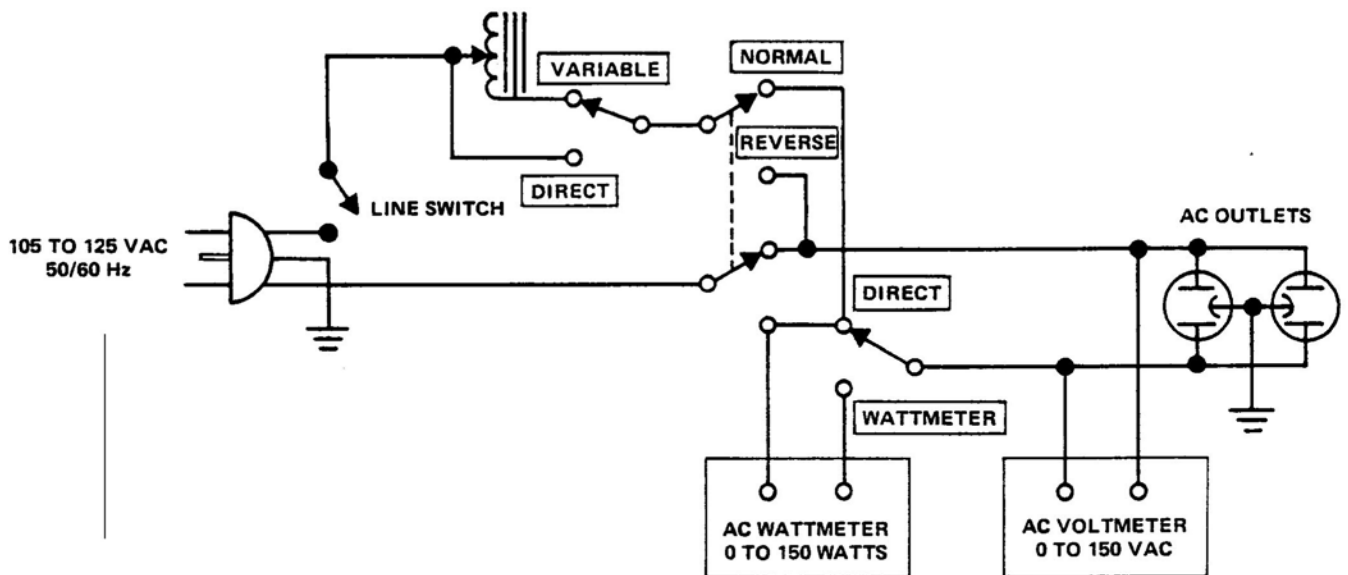

Figure 4. AC Power Control Box Simplified Schematic

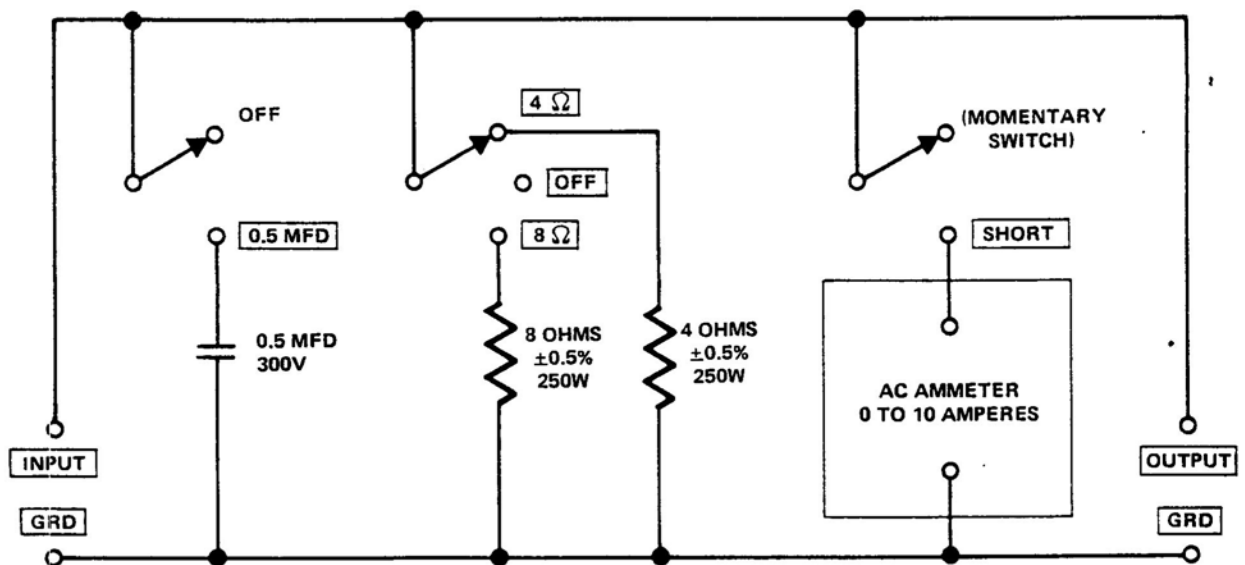

Figure 5. Amplifier Output Load Box Simplified Schematic

TROUBLE ANALYSIS

The following section is designed to assist in locating troubles. The information given is to help in situations where problems may be difficult to isolate. Any field problems that arise will be covered through service bulletins (supplementary to this manual) that will be issued to all service stations. It is assumed that normal trouble-shooting techniques (i.e., point-to-point signal tracing, oscilloscope analysis, etc.) will be used to isolate problems.

NOTE: Performance verification is necessary following any repair.

SYMPTOM	PROCEDURE
1. Excessive line consumption (100 watts or more)	<ol style="list-style-type: none"> a. Check for shorted rectifiers CR301 through CR304, CR305, or CR306. Also check C1, C2. b. Check for shorted transistors Q802 through Q805, Q507, Q508, Q510 or Q511. Check for open control R224, 215-1005-1 bias assembly. Check T1 for short.
<p>CAUTION: Because the driver and output stages are direct coupled, components may fail as a direct result of an initial component failure. If a shorted semiconductor is found, be sure to check the remaining driver and output components for short or open circuits before re-energizing the amplifier. After replacement of any of these components, increase the Variac voltage slowly while monitoring the wattmeter as described in paragraph C of Performance Verification.</p>	
2. No line consumption or zero bias.	<ol style="list-style-type: none"> a. Check line cord, fuse, transistors Q507, Q508, Q510, Q511, Q802 through Q805, 215-1005-1 bias assembly. b. Check for open rectifiers CR301 through CR304, CR305, CR306 or open T1.
3. High DC voltage at loudspeaker terminals before time delay circuit is deactivated.	<ol style="list-style-type: none"> a. Check transistors Q301 through Q303 for leakage, shorted, or open.
4. High DC voltage at loudspeaker at all times.	<ol style="list-style-type: none"> a. Check R301 through R305 for open and Q301 through Q303 for leakage, shorted, or open.
5. No DC Balance.	<ol style="list-style-type: none"> a. Check Q501, Q502, R502, and Zener diodes CR501 and CR502 b. Check R501, R503.
6. High hum and noise level.	<ol style="list-style-type: none"> a. Check filter capacitors, C1, C2, C501 and C504.
7. Parasitic Oscillation.	<ol style="list-style-type: none"> a. Check for defective C506, C509, C516, and C505.

8. Improper clipping.

9. Relay Latching

10. No meter indication of output.

a. Check for proper adjustment of R541, R542.

b. Check for transistors Q802 through Q805.

a. Check Q301 through Q303.

b. Check output for proper clipping (positive and negative levels must not vary more than 1 volt at 2 KHz).

c. Check for high level DC offset at junctions R302 and R305.

a. Check Q401 through Q404. Check for defective M1, M2 (meters), open C401, C404, open CR405 through CR408 and CR415 through CR418.

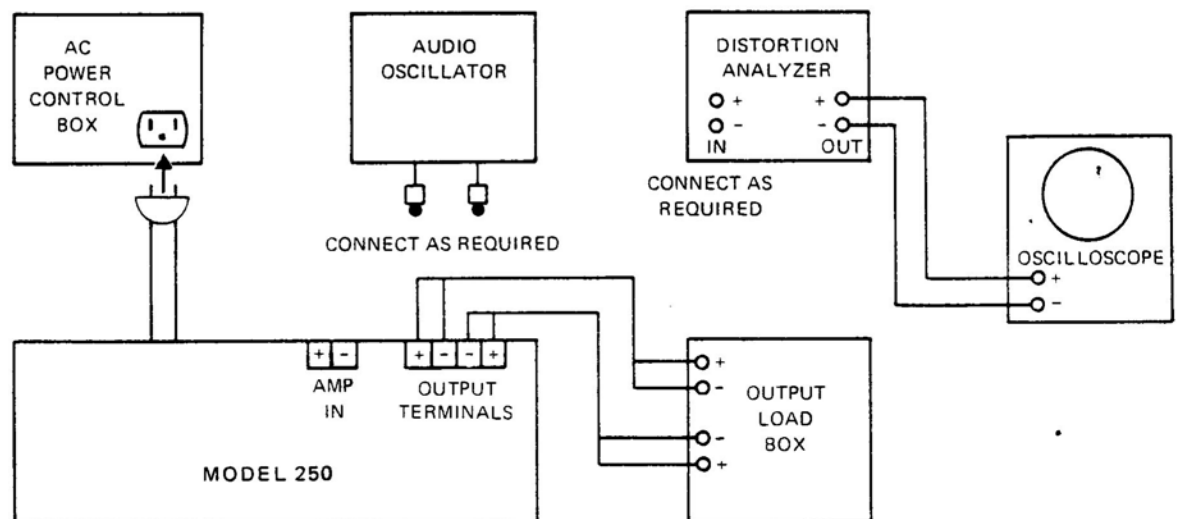

Figure 6. Test Equipment Set-Up

for proper adjustment of R541, R542.
for transistors Q802 through Q805.
Q301 through Q303.

output for proper clipping (positive
negative levels must not vary more than
at 2 KHz).

for high level DC offset at junction of
and R305.

Q401 through Q404. Check for
ive M1, M2 (meters), open C401 or
open CR405 through CR408 and
5 through CR418.

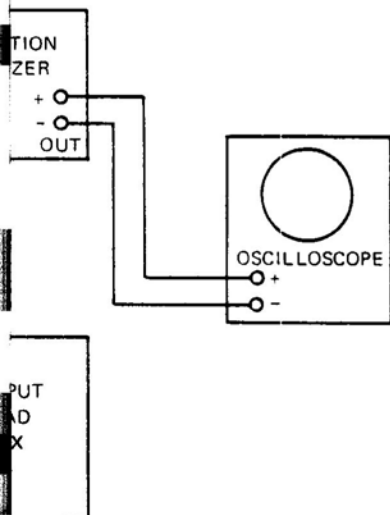

PARTS LIST

Reference Designation	Description and/or Remarks	Marantz Part Number
A1, A2	HEATSINK ASSEMBLY	215-1005-3
	Transistor Socket	368-1000
C501	Cap. 150 pf, $\pm 10\%$, 100V	385-1038
C502	Cap. Elec., 10 μ f, 25V	381-1034
C503	Cap. Elect., 10 μ f, 25V	381-1034
C504	Cap. Elect., 10 μ f, 25V	381-1034
C505	Cap. 47 pf, $\pm 10\%$, 100V	385-1040
C506	Cap. 680 pf, $\pm 5\%$, 100V	385-1042
C507	Cap. Elect., 220 μ f, 6.3V	381-1044
C508	Cap. 36 pf, $\pm 5\%$, 100V	385-1064
C509	Cap. 36 pf, $\pm 5\%$, 300V	385-1018
C510	Cap. 0.1 μ f, $\pm 10\%$, 250V	386-1000
C511	Cap. 0.1 μ f, $\pm 10\%$, 250V	386-1000
C512	Cap. 410 pf, $\pm 10\%$, 100V	385-1055
C513	Cap. 0.22 μ f, $\pm 10\%$, 250V	386-1017
C514	Cap. 1600 pf, $\pm 10\%$, 300V	385-1020
C515	Cap. 1600 pf, $\pm 10\%$, 300V	385-1020
C516	Cap. 0.1 μ f, $\pm 10\%$, 250V	386-1000
C517	Cap. 1.0 μ f, $\pm 20\%$, 100V	388-1001
C518	Cap. 130 pf, $\pm 10\%$, 300V	385-1019
CR501	Diode, Zener	459-1006
CR502	Diode, Zener	459-1006
L501	Toroid	147-1007
R501	Res. C/F, 7.5K, $\pm 5\%$, 1/2W	433-4752
R502	Res. Variable, 2K, 2W	420-1000
R503	Res. C/F, 4.7K, $\pm 5\%$, 1/2W	433-4472
R504	Res. C/F, 100K, $\pm 5\%$, 1/4W	434-6102
R505	Res. C/F, 470K, $\pm 5\%$, 1/4W	434-6472
R506	Res. C/F, 1K, $\pm 5\%$, 1/4W	434-4102
R507	Res. C/F, 100K, $\pm 5\%$, 1/4W	434-6102
R508	Res. C/F, 7.5K, $\pm 5\%$, 1/2W	433-4752
R509	Res. C/F, 3.3K, $\pm 5\%$, 1/4W	434-4332
R510	Res. C/F, 8.2K, $\pm 5\%$, 1/4W	434-4822
R511	Res. C/F, 680 ohm, $\pm 5\%$, 1/4W	434-3682
R512	Res. C/F, 7.5K, $\pm 5\%$, 1/2W	433-4752
R513	Res. Prec., 1K, $\pm 1\%$, 1/4W	431-4100
R514	Res. C/F, 2K, $\pm 5\%$, 1/4W	434-4202
R515	Res. C/F, 27 ohm, $\pm 5\%$, 1/2W	433-2272
R516	Res. C/F, 220 ohm, $\pm 5\%$, 1/4W	434-3222
R517	Res. W/W, 1.5K, $\pm 10\%$, 2W	436-4153
R518	Res. W/W, 1.5K, $\pm 10\%$, 2W	436-4153
R519	Res. Prec., 20K, $\pm 1\%$, 1/4W	431-5200
R520	Res. C/F, 100K, $\pm 5\%$, 1/4W	434-6102
R521	Res. C/F, 300 ohm, $\pm 5\%$, 1/4W	434-3302

Reference Designation	Description and/or Remarks	Marantz Part Number
R522	Res. C/F, 560 ohm, $\pm 5\%$, 1/2W	433-3562
R523	Res. C/F, 560 ohm, $\pm 5\%$, 1/2W	433-3562
R524	Res. C/F, 27K, $\pm 5\%$, 1/4W	434-5272
R525	Res. C/F, 27K, $\pm 5\%$, 1/4W	424-5272
R526	Res. Variable, 1K, 2W	420-1011
R527	Res. C/F, 47 ohm, $\pm 5\%$, 1/2W	433-2472
R528	Res. C/F, 47 ohm, $\pm 5\%$, 1/2W	433-2472
R529	Res. C/C, 39 ohm, $\pm 10\%$, 1W	423-2392
R530	Res. C/C, 39 ohm, $\pm 10\%$, 1W	423-2392
R531	Res. W/W, 0.1 ohm, $\pm 5\%$, 5W	145-1002
R532	Res. W/W, 0.1 ohm, $\pm 5\%$, 5W	145-1002
R533	Res. W/W, 0.15 ohm, $\pm 10\%$, 5W	428-0153
R534	Res. W/W, 0.15 ohm, $\pm 10\%$, 5W	428-0153
R535	Res. W/W, 0.15 ohm, $\pm 10\%$, 5W	428-0153
R536	Res. W/W, 0.15 ohm, $\pm 10\%$, 5W	428-0153
R537	Res. C/F, 330 ohm, $\pm 5\%$, 1/4W	434-3332
R538	Res. C/F, 330 ohm, $\pm 5\%$, 1/4W	434-3332
R539	Res. C/C, 27 ohm, $\pm 5\%$, 2W	424-2272
R540	Res. C/F, 2.2K, $\pm 5\%$, 1/2W	433-4222
R541	Res. Variable, 2.5K, 1/4W	420-1019
R542	Res. Variable, 2.5K, 1/4W	420-1019
R543	Res. C/F, 2.2K, $\pm 5\%$, 1/2W	433-4222
R544	Res. C/F, 1K, $\pm 5\%$, 1/2W	433-4102
R545	Res. C/F, 1K, $\pm 5\%$, 1/2W	433-4102
R546	Res. BWH, 1.0 ohm, $\pm 5\%$, 2W	436-1102
R547	Res. C/F, 2.2K, $\pm 5\%$, 1/4W	434-4222
R548	Res. C/F, 2.7K, $\pm 5\%$, 1/4W	434-4272
R549	Res. C/F, 10K, $\pm 5\%$, 1/4W	434-5102
R550	Res. C/F, 1K, $\pm 5\%$, 1/4W	434-4102
R551	Res. C/F, 270K, $\pm 5\%$, 1/4W	434-6272
Q501	Transistor, NPN	462-1038
Q502	Transistor, NPN	462-1038
Q503	Transistor, PNP	461-1037
Q504	Transistor, NPN	462-1044
Q505	Transistor, PNP	461-1036
Q506	Transistor, NPN	462-1042
Q507	Transistor, PNP	461-1003
Q508	Transistor, NPN	462-1004
Q509	Not Used	
Q510	Transistor, NPN	462-1040
Q511	Transistor, PNP	461-1034
Q512	Not Used	
Q513	Not Used	
Q514	Not Used	
Q515	Not Used	
Q516	Transistor, NPN	462-1035
Q517	Transistor, PNP	461-1030

Reference Designation	Description and/or Remarks	Marantz Part Number
Q518	Transistor, PNP	461-1013
Q519	Transistor, PNP	461-1013
C801	Cap. 0.1 μ f, $\pm 10\%$, 250V	386-1000
CR801	Diode	460-1011
Q801	Transistor, NPN	462-1043
	Heat Sensor Assy.	215-1006-1
Q802	Transistor, PNP	461-1031
Q803	Transistor, NPN	462-1036
Q804	Transistor, PNP	461-1031
Q805	Transistor, NPN	462-1036
A3	RECTIFIER/RELAY BOARD ASSEMBLY	200-1027-1
C301	Cap. Elect., 22 μ f, 25V	381-1046
C302	Cap. Elect., 220 μ f, 6.3V	381-1044
C303	Cap. Elect., 22 μ f, 63V	381-1040
CR301	Diode	460-1014
CR302	Diode	460-1014
CR303	Diode	460-1014
CR304	Diode	460-1014
CR305	Diode	460-1013
CR306	Diode	460-1013
K301	Relay, DPDT	410-1000
R301	Res. C/F, 12K, $\pm 5\%$, 1/2W	433-5122
R302	Res. C/F, 10K, $\pm 5\%$, 1/2W	433-5102
R303	Res. C/F, 75K, $\pm 5\%$, 1/2W	433-5752
R304	Res. C/F, 75K, $\pm 5\%$, 1/2W	433-5752
R305	Res. C/F, 7.5K, $\pm 5\%$, 1/2W	433-4752
R306	Res. C/F, 27K, $\pm 5\%$, 1/2W	433-5272
R307	Res. W/W, 2.2K, $\pm 5\%$, 2W	436-4222
R308	Res. W/W, 2.2K, $\pm 5\%$, 2W	436-4222
R309	Res. C/F, 470K, $\pm 5\%$, 1/2W	433-6472
R310	Res. W/W, 560 ohm, $\pm 5\%$, 5W	428-3562
Q301	Transistor, NPN	462-1000
Q302	Transistor, NPN	462-1007
Q303	Transistor, NPN	462-1000
	Standoff, Swage, #6-32	560-4042

Reference Designation	Description and/or Remarks	Marantz Part Number	Reference Designation	Description and/or Remarks	Marantz Part Number
A4	METER BOARD COMPONENT ASSEMBLY	200-1030-1	R421	Res. C/F, 10K, $\pm 5\%$, 1/4W	434-5102
C401	Cap. Elect., 2.2 μ f, 40V	381-1038	R422	Res. C/F, 100K, $\pm 5\%$, 1/4W	434-6102
C402	Cap. Elect., 47 μ f, 10V	381-1037	R423	Res. C/F, 10K, $\pm 5\%$, 1/4W	434-5102
C403	Cap. Elect., 47 μ f, 10V	381-1037	R424	Res. Variable, 5K, 1/4W	420-1020
C404	Cap. Elect., 2.2 μ f, 40V	381-1038	R425	Res. C/F, 10K, $\pm 5\%$, 1/4W	434-5102
C405	Cap. Elect., 47 μ f, 10V	381-1037	R426	Res. C/F, 47K, $\pm 5\%$, 1/4W	434-5472
C406	Cap. Elect. 47 μ f, 10V	381-1037	R427	Res. C/F, 100 ohm, $\pm 5\%$, 1/4W	434-3102
CR401	Diode	460-1009	R428	Res. C/F, 3.9K, $\pm 5\%$, 1/2W	433-4392
CR402	Diode	460-1009	R429	Res. C/F, 1K, $\pm 5\%$, 1/4W	434-4102
CR403	Diode, Zener, 6.2V	459-1002	R430	Res. Variable, 5K, 1/4W	420-1020
CR404	Diode, Zener, 6.2V	459-1002	Q401	Transistor, NPN	462-1009
CR405	Diode	460-1009	Q402	Transistor, PNP	461-1013
CR406	Diode	460-1009	Q403	Transistor, NPN	462-1009
CR407	Diode	460-1009	Q404	Transistor, PNP	461-1013
CR408	Diode	460-1009	MISCELLANEOUS PARTS		
CR409	Diode, Zener, 13V	459-1004	J1	A.C. Outlet	360-1001
CR410	Diode, Zener, 13V	459-1004	J2 & J3	Input Jack	360-1009
CR411	Diode	460-1009	TB2	Speaker Terminal Block	363-1003
CR412	Diode	460-1009	XF1	Fuse Holder (w/Mtg Hardware)	367-1001
CR413	Diode, Zener, 6.2V	459-1002	C1	Cap. Elect., 20,000 μ f, 60V	381-1041
CR414	Diode, Zener, 6.2V	459-1002	C2	Cap. Elect., 20,000 μ f, 60V	381-1041
CR415	Diode	460-1009	T1	Transformer, Power	440-1008
CR416	Diode	460-1009	F1	Fuse, 6 amp, 250V	451-1013
CR417	Diode	460-1009	S1 & S2	Switch, Meter Range	453-1017
CR418	Diode	460-1009		Plastic Foot	567-1000
R401	Res. C/F, 3.3K, $\pm 5\%$, 1/4W	434-4332	R1	Res. C/F, 2.4K, $\pm 5\%$, 1/2W	433-4242
R402	Res. C/F, 4.7K, $\pm 5\%$, 1/4W	434-4472	R2	Res. C/F, 2.4K, $\pm 5\%$, 1/2W	433-4242
R403	Res. C/F, 3.3K, $\pm 5\%$, 1/4W	434-4332		Front Panel	134-1021-1
R404	Res. C/F, 2.7K, $\pm 5\%$, 1/4W	434-4272		Knob	174-1008
R405	Res. C/F, 10K, $\pm 5\%$, 1/4W	434-5102	M1 & M2	Meter	865-1001
R406	Res. C/F, 100K, $\pm 5\%$, 1/4W	434-6102		Escutcheon	134-1022
R407	Res. C/F, 10K, $\pm 5\%$, 1/4W	434-5102		Shroud, Meter Lamp	136-1018
R408	Res. Variable, 5K, 1/4W	420-1020	XDS1 thru XDS4	Light Socket	481-1003
R409	Res. C/F, 10K, $\pm 5\%$, 1/4W	434-5102	DS1 thru DS4	Lamp	482-1006
R410	Res. C/F, 47K, $\pm 5\%$, 1/4W	434-5472			
R411	Res. C/F, 100 ohm, $\pm 5\%$, 1/4W	434-3102			
R412	Res. C/F, 3.9K, $\pm 5\%$, 1/2W	433-4392			
R413	Res. C/F, 1K, $\pm 5\%$, 1/4W	434-4102			
R414	Res. Variable, 5K, 1/4W	420-1020			
R415	Res. C/C, 2.2K, $\pm 5\%$, 1W	423-4222			
R416	Res. C/C, 2.2K, $\pm 5\%$, 1W	423-4222			
R417	Res. C/F, 3.3K, $\pm 5\%$, 1/4W	434-4332			
R418	Res. C/F, 4.7K, $\pm 5\%$, 1/4W	434-4472			
R419	Res. C/F, 3.3K, $\pm 5\%$, 1/4W	434-4332			
R420	Res. C/F, 2.7K, $\pm 5\%$, 1/4W	434-4272			

*See ECN Change Record

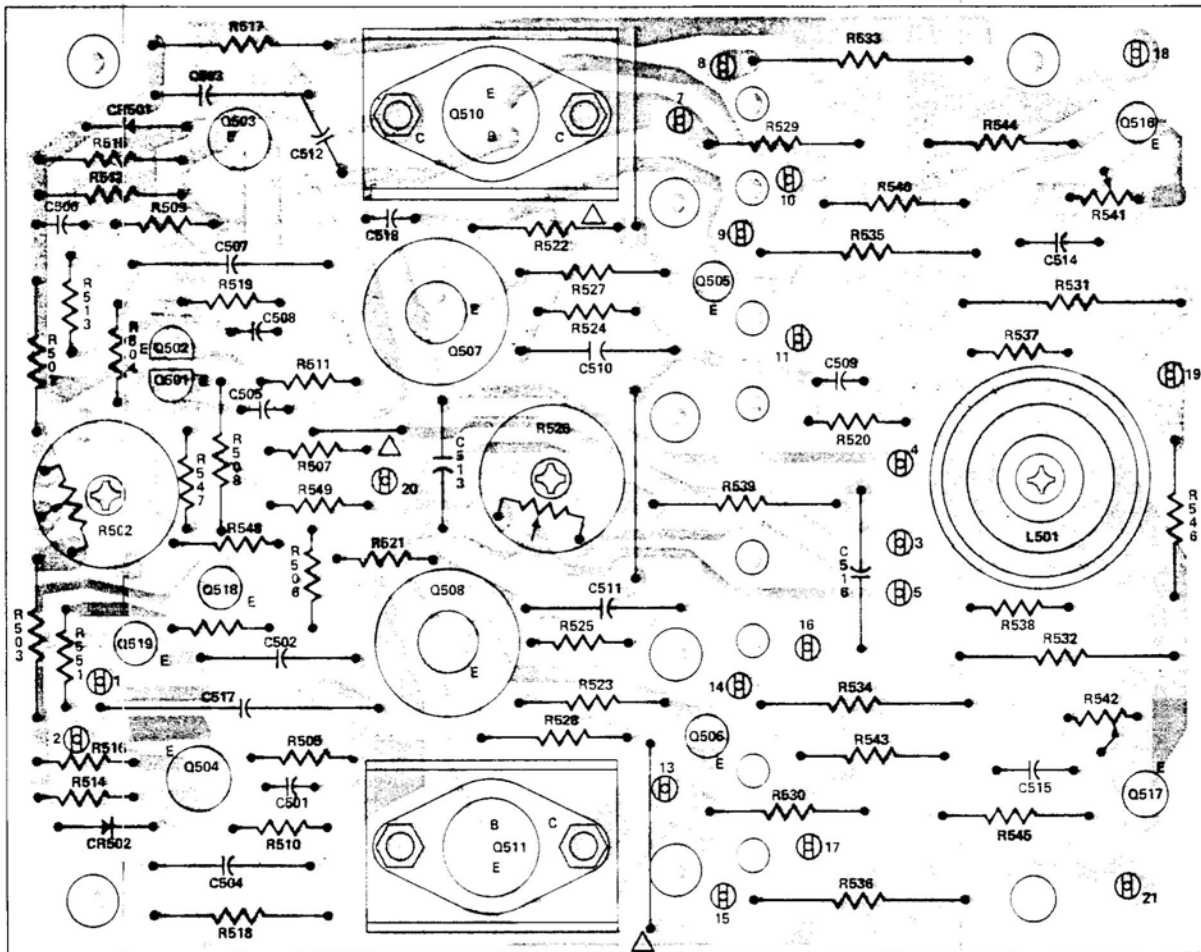
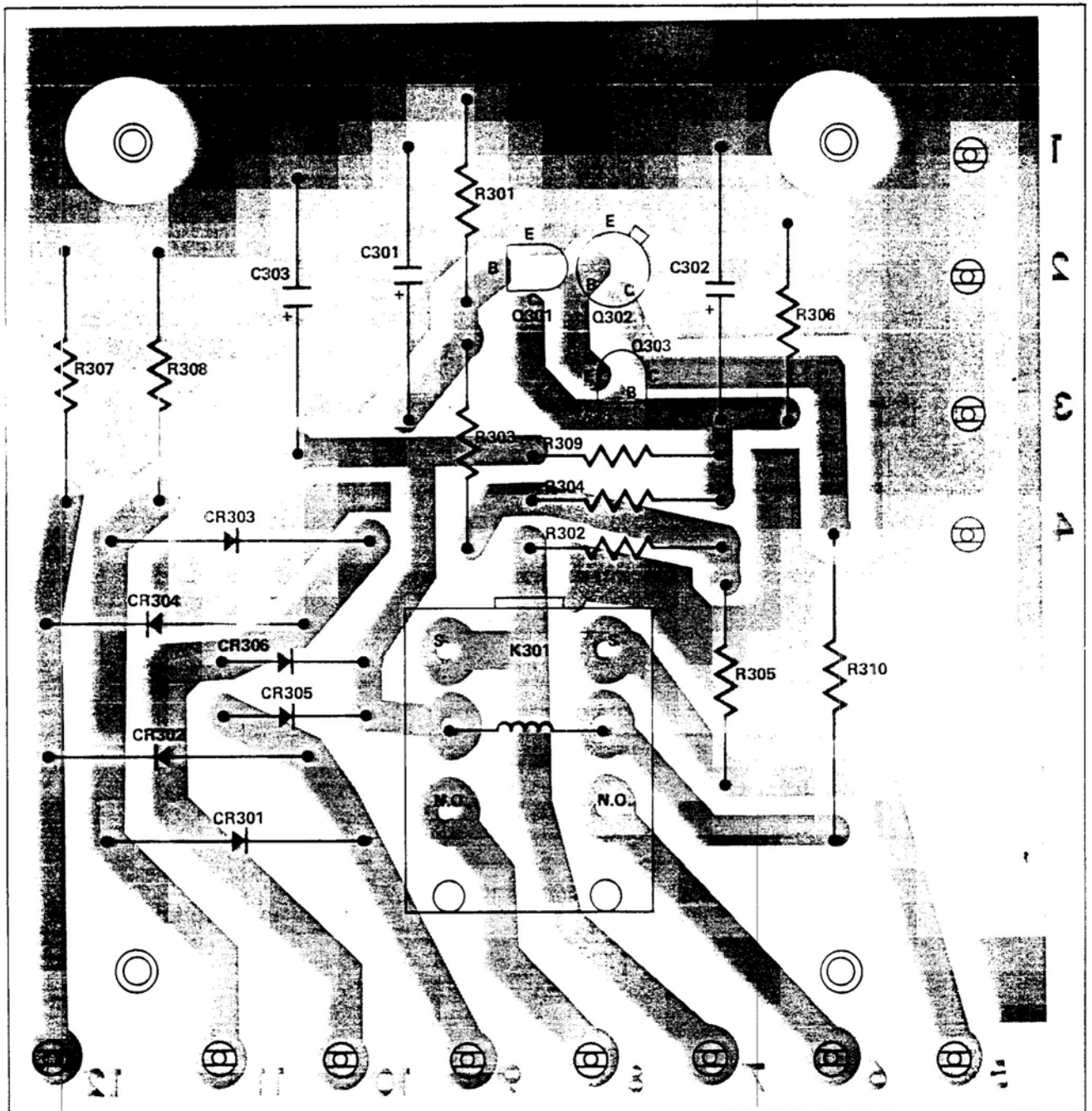

Figure 7. Power Amplifier Board Component Assembly Diagram



COMPONENT SIDE SHOWN
CONDUCTOR ON FAR SIDE

CR301 THRU CR304 TO BE MOUNTED 1/8" OFF BOARD. FAR SIDE

Figure 8. Rectifier/Relay Board Component Assembly Diagram

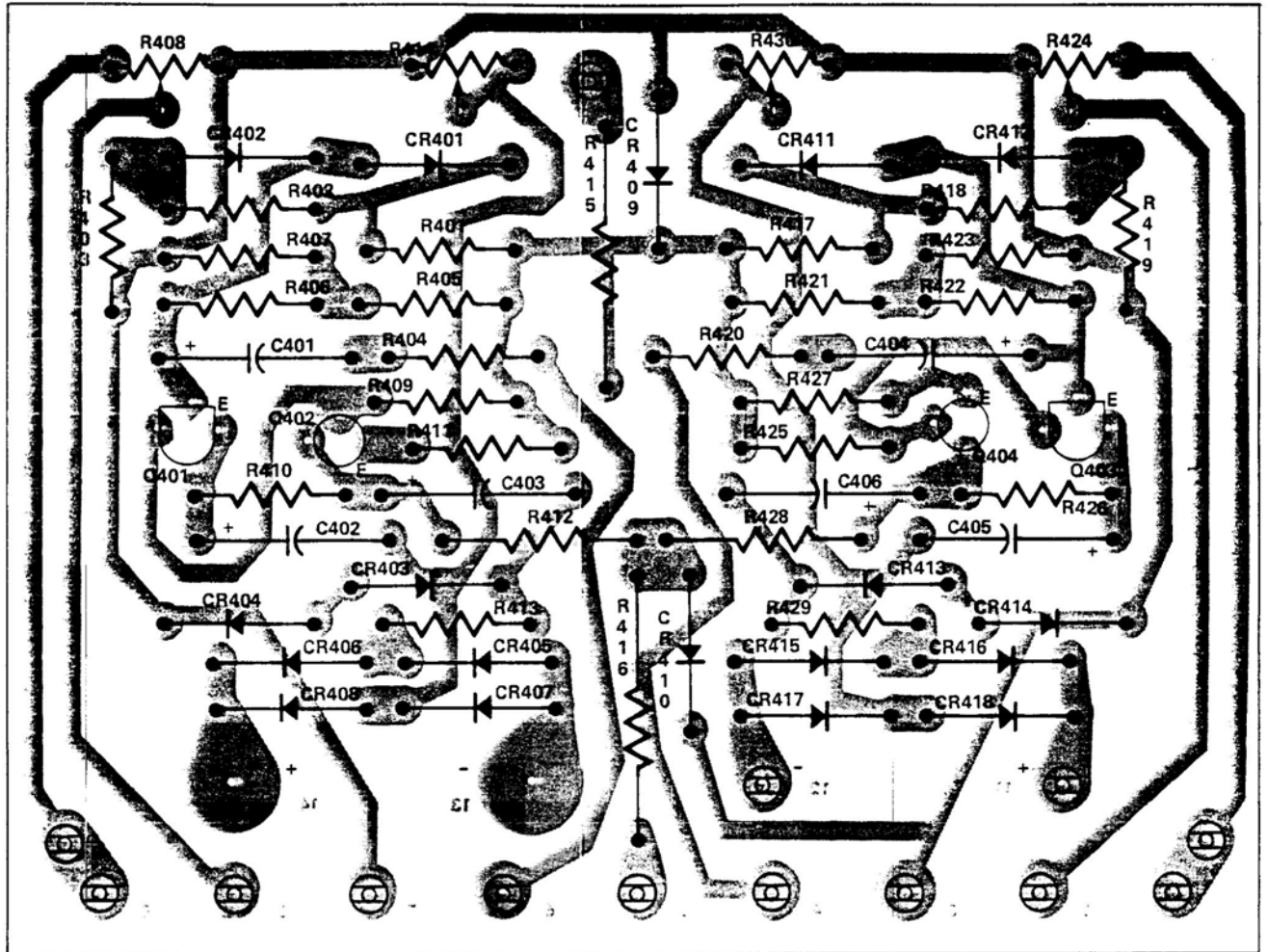

WHEN VIEWING BLACK DOT ON C401 AND C404 WITH LEADS DOWN' POSITIVE LEAD IS ON RIGHT,
 (APPLICABLE ONLY TO APPROVED ALTERNATE PART)

Figure 9. Meter Board Component Assembly Diagram

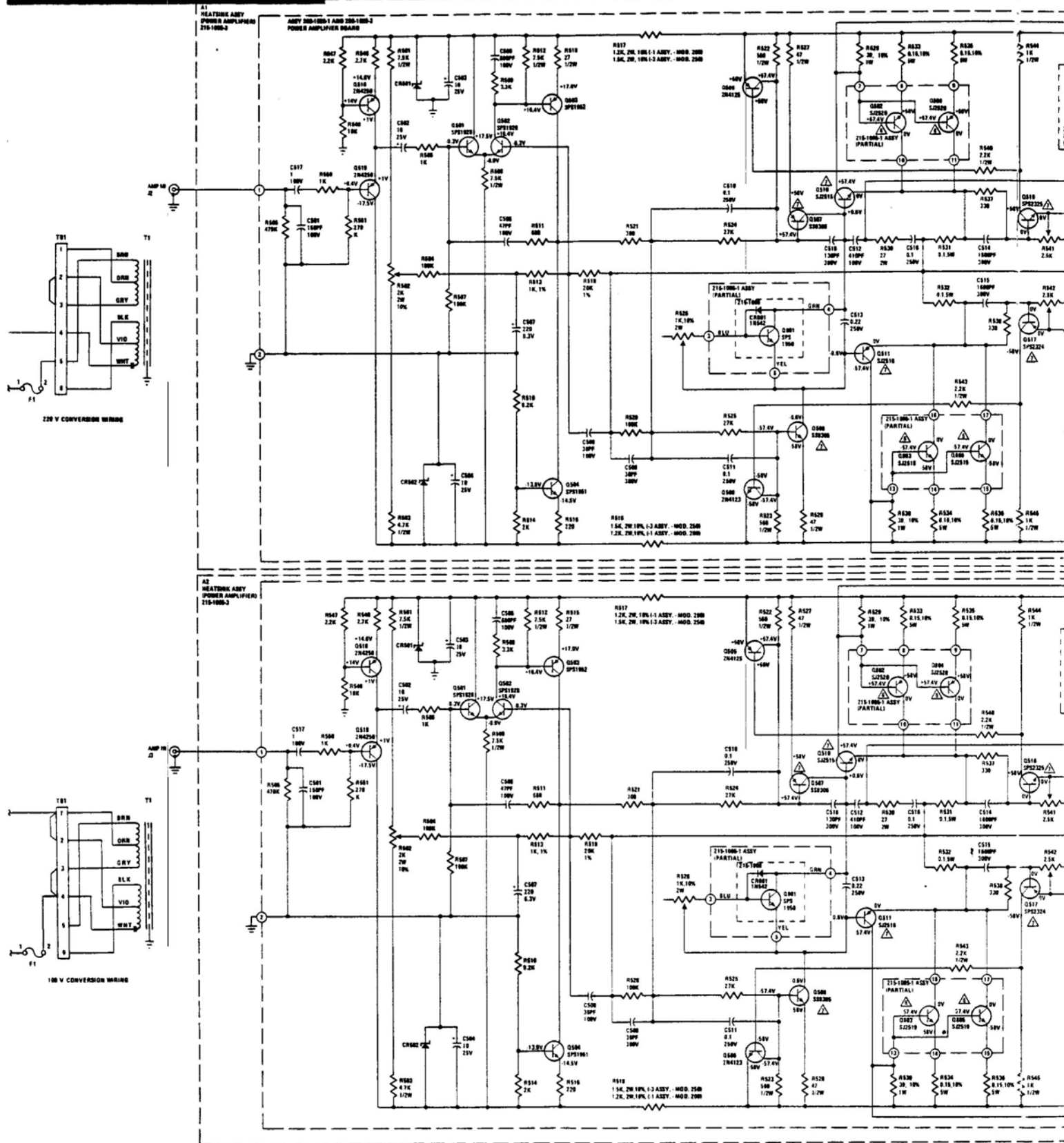
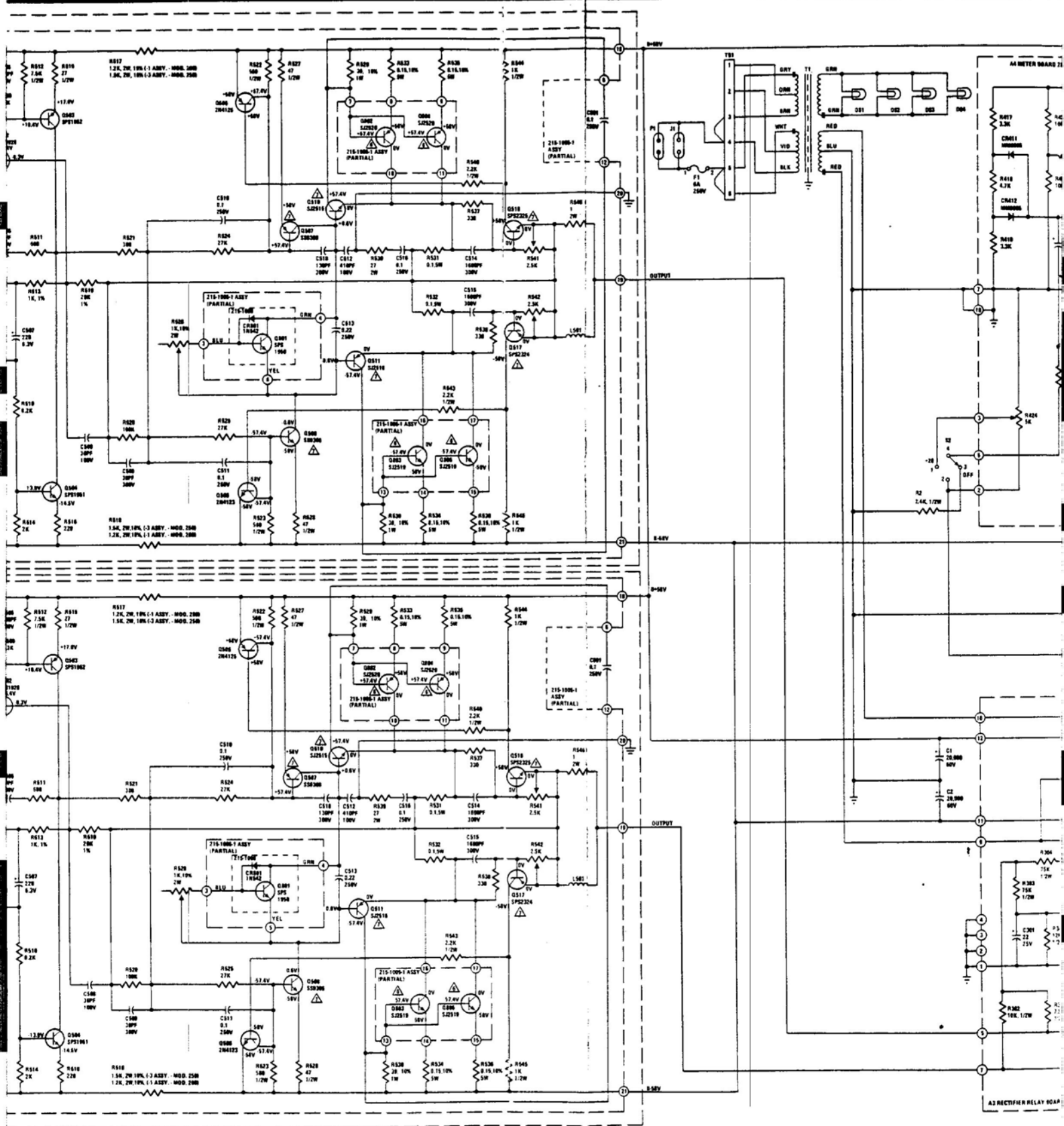
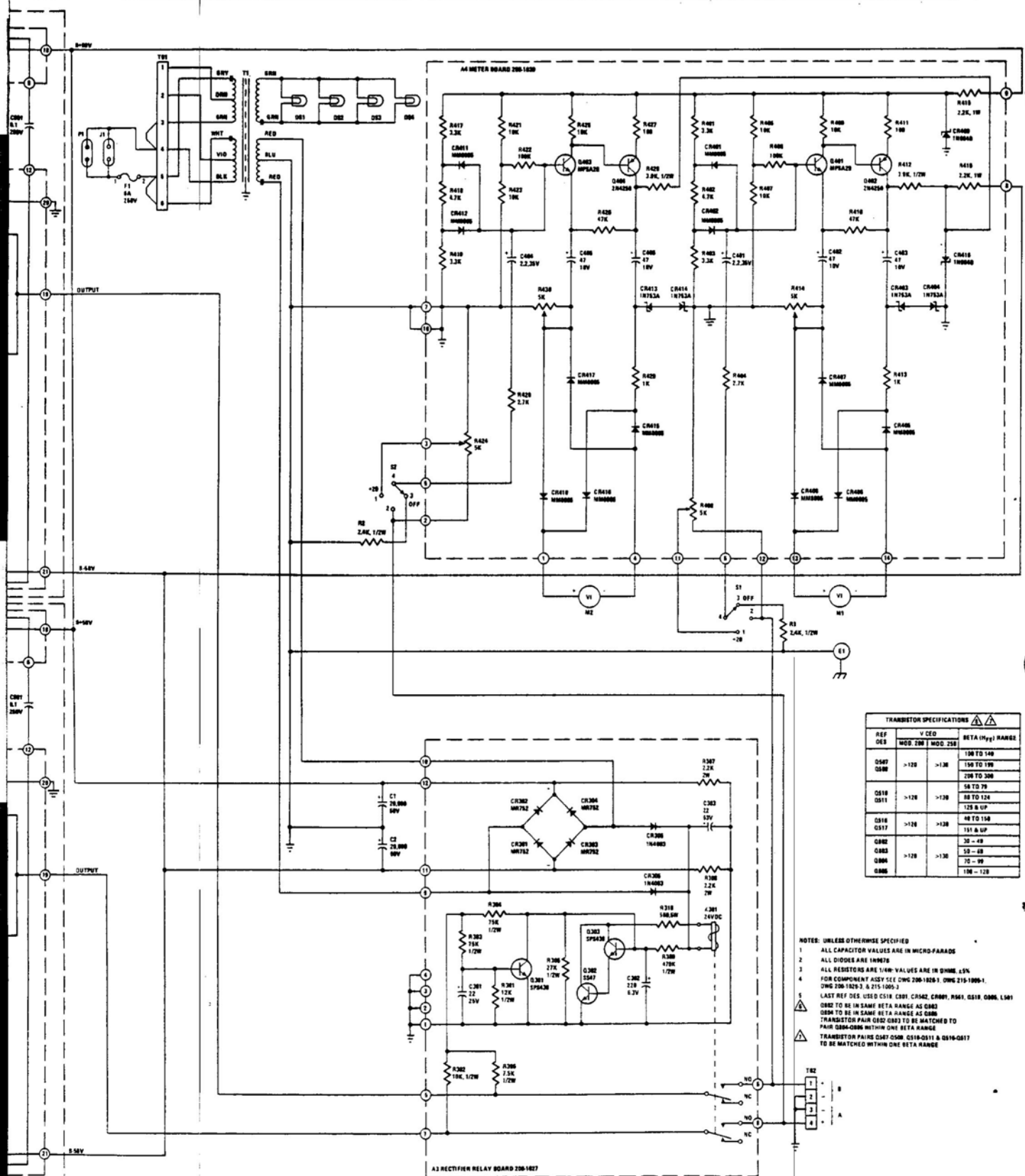

Figure 10. Model 250 Schematic





TRANSISTOR SPECIFICATIONS			
REF DES	V _{CE0}		BETA (h _{FE}) RANGE
	MOD 206	MOD 208	
Q407 Q408	>120	>130	150 TO 140 150 TO 190 200 TO 300
Q410 Q411	>120	>130	50 TO 70 80 TO 120 125 B UP
Q412 Q413	>120	>130	40 TO 150 151 & UP
Q402 Q403	>120	>130	30 - 40 35 - 50
Q404 Q405	>120	>130	70 - 90 100 - 120

NOTES: UNLESS OTHERWISE SPECIFIED
 1 ALL CAPACITOR VALUES ARE IN MICRO-FARADS
 2 ALL DIODES ARE 1N9670
 3 ALL RESISTORS ARE 1/4W- VALUES ARE IN OHMS, 15%
 4 FOR COMPONENT ASSEMBLY SEE DWS 206-1028-1, DWS 215-1000-1,
 DWS 206-1028-3, & 215-1000-3
 5 LAST REF DES USED Q410, Q411, Q412, Q413, Q414, Q415, Q416, Q417
 Q402 TO BE IN SAME BETA RANGE AS Q403
 Q404 TO BE IN SAME BETA RANGE AS Q405
 TRANSISTOR PAIR Q402-Q403 TO BE MATCHED TO
 PAIR Q404-Q405 WITHIN ONE BETA RANGE
 TRANSISTOR PAIRS Q407-Q408, Q410-Q411 & Q412-Q413
 TO BE MATCHED WITHIN ONE BETA RANGE