

119



**SERVICE
MANUAL 300DC**



marantz

model 300DC

Power Amplifier

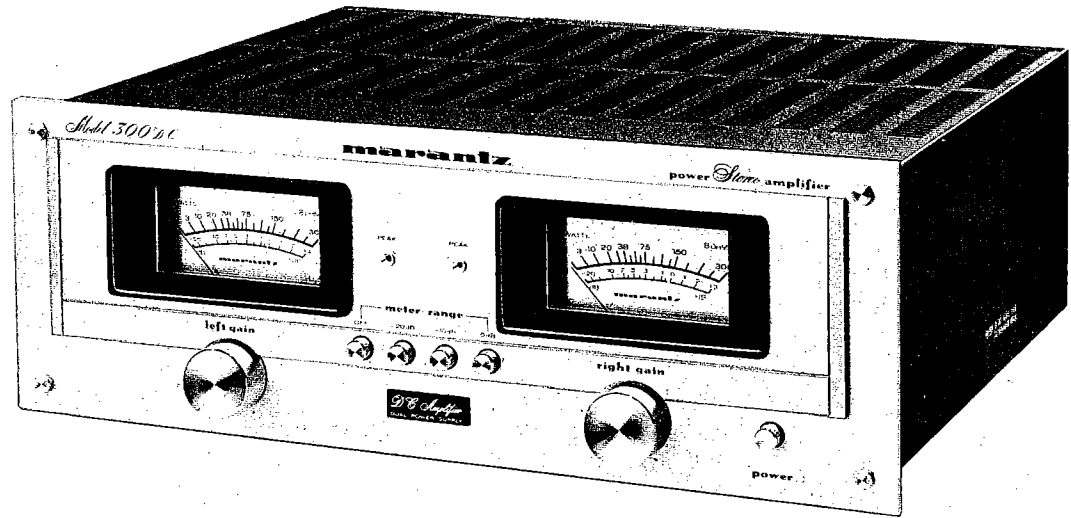

TABLE OF CONTENTS

SECTION	PAGE
1. INTRODUCTION	1
2. TEST EQUIPMENT REQUIRED FOR SERVICING	1
3. ALIGNMENT PROCEDURE	2
3.1 DC Balance	2
3.2 Meter Adjustment	2
4. VOLTAGE CONVERSION FOR EUROPE	2
5. DIAGRAM AND COMPONENT LOCATIONS	3
5.1 Main Amp. Assembly (P700) Schematic Diagram and Component Locations	3
5.2 Peak Ind. Assembly (PN00) Schematic Diagram and Component Locations	4
5.3 Power Supply Assembly (P800) Schematic Diagram and Component Locations	5
5.4 RCA Pin Terminal Assembly (PM00) Schematic Diagram and Component Locations	5
5.5 Meter Range Assembly (PS00) Schematic Diagram and Component Locations	5
5.6 Fuse Assembly (PP00) Schematic Diagram and Component Locations	5
6. BLOCK DIAGRAM	6
7. SCHEMATIC DIAGRAM	7
8. EXPLODED VIEW AND PARTS LIST	9
9. TECHNICAL SPECIFICATIONS	21

1. INTRODUCTION

This service manual was prepared for use by Authorized Warranty Stations and contains service information for Marantz Model 300DC Main Amplifier.

Servicing information and voltage data included in this manual are intended for use by the knowledgeable and experienced technician only. All instructions should be read carefully. No attempt should be made to proceed

without a good understanding of the operations in the receiver.

The parts list furnishes information by which replacement parts may be ordered from the Marantz Company. A simple description is included for parts which can usually be obtained through local suppliers.

2. TEST EQUIPMENT REQUIRED FOR SERVICING

Table 1 lists the test equipment required for servicing the Model 300DC Main Amplifier.

Item	Manufacturer and Model No.	Use
Distortion Analyzer Audio Oscillator AC VTVM	Sound Technology Model 1700B	Distortion measurements Sinewave and squarewave signal source voltage measurements (AC)
Oscilloscope	Tektronix Model T932 Philips Model 3232	Waveform analysis and trouble shooting and ASO alignment
Circuit Tester		Trouble shooting
DC VTVM	Fluke Model 8000 "Digital" Simpson Model 313, Triplet Model 801	Voltage measurements (DC)
AC Wattmeter	Simpson Model 1379	Monitors primary power to amplifier
AC Ammeter	Commercial Grade (1-10A)	Monitors amplifier output under short circuit condition
Line Voltmeter	Simpson Model 1359	Monitors potential of primary power to amplifier
Variable Autotransformer	Superior Electronic Co., Powerstat Model 116B-10A	Adjusts level of primary power to amplifier
Shorting Plug	Use phono plug with 600 ohm across center pin and shell	Shorts amplifier input to eliminate noise pickup
Output Load (8 ohms, ± 0.5% 100W)	Commercial Grade	Provides 8-ohm load for amplifier output termination
Output Load (4 ohms, ± 0.5% 100W)	Commercial Grade	Provides 4-ohm load for amplifier output termination

3. ALIGNMENT PROCEDURE

3.1 DC Balance

1. Connect oscilloscope to Left Channel output terminals of the Model 300DC.
2. Turn Line Switch to ON and adjust variac to 120 vac.
3. After relay energizes, adjust Left Channel (Left Hand Heatsink) amplifier board potentiometer R719 for an indication of a "line" zero (i.e., 0V \pm 50 mV) as indicated on the oscilloscope.
4. Repeat for Right Channel (Right Hand Heatsink).

3.2 Meter Adjustment

1. Fully turn RN03 (RN04) clockwise and RN01 (RN02) counterclockwise.
2. Turn meter range switch to 0 dB position.
3. Set the output of the speaker terminal to 34.5 V R.M.S.
4. Set the meters (M001, M002) to "0VU" by RN01 (RN02).
5. Decrease the output of the speaker terminal to 6.2 V R.M.S.
Turn meter range switch to -20 dB position.
Turn RN03 (RN04) in the clockwise direction and stop where the meter's pointer hits the full scale stopper.

● **EUROPEAN MODEL ONLY**

4. VOLTAGE CONVERSION

This Model is equipped with a universal power transformer to permit operation at 110, 120, 220 and 240 V AC 50/60 Hz.
To convert the unit to the required voltage, set the plug as illustrated so that you can adjust the voltage as required.

CAUTION
DISCONNECT POWER SUPPLY CORD FROM AC OUTLET BEFORE CONVERTING VOLTAGE.

4.1 Voltage Conversion Chart

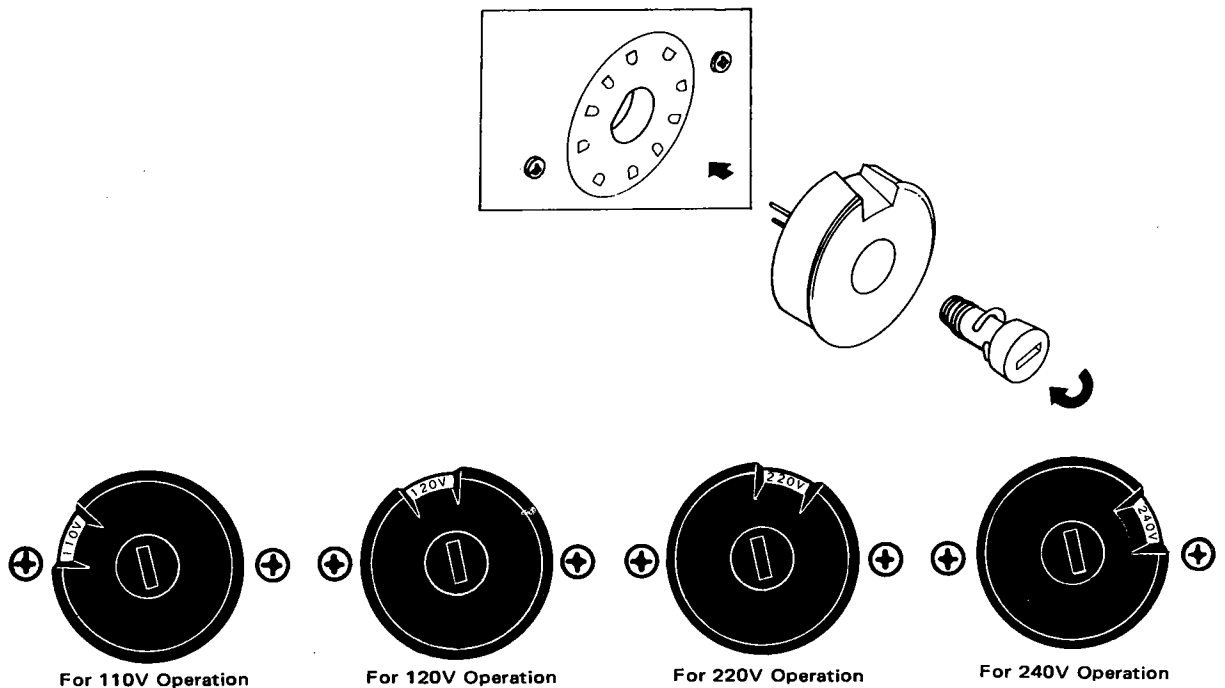

5. DIAGRAM AND COMPONENT LOCATIONS

5.1 Main Amp. Assembly (P700) Schematic Diagram and Component Locations

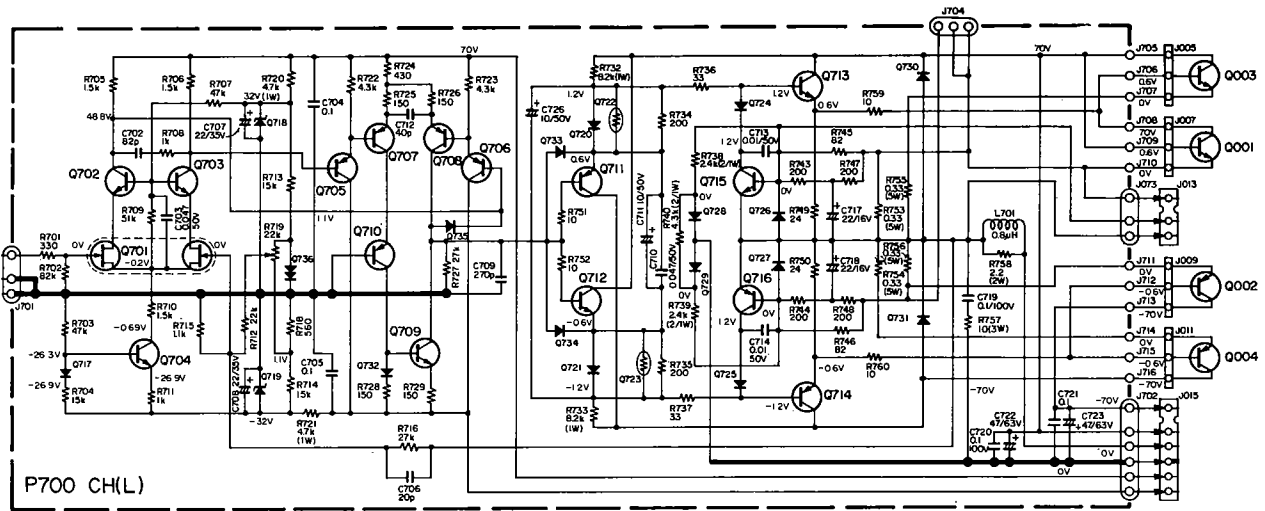

P700 CH(L)

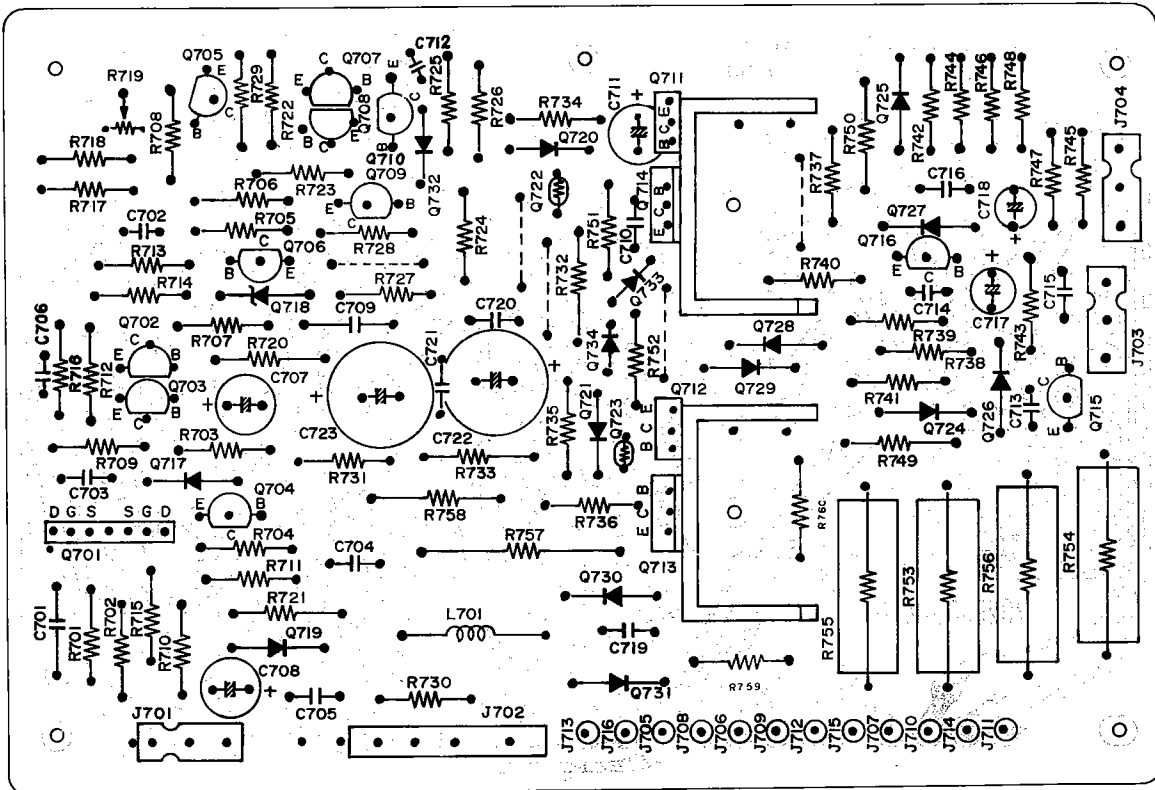

5.2 Peak Ind Assembly (PN00) Schematic Diagram and Component Locations

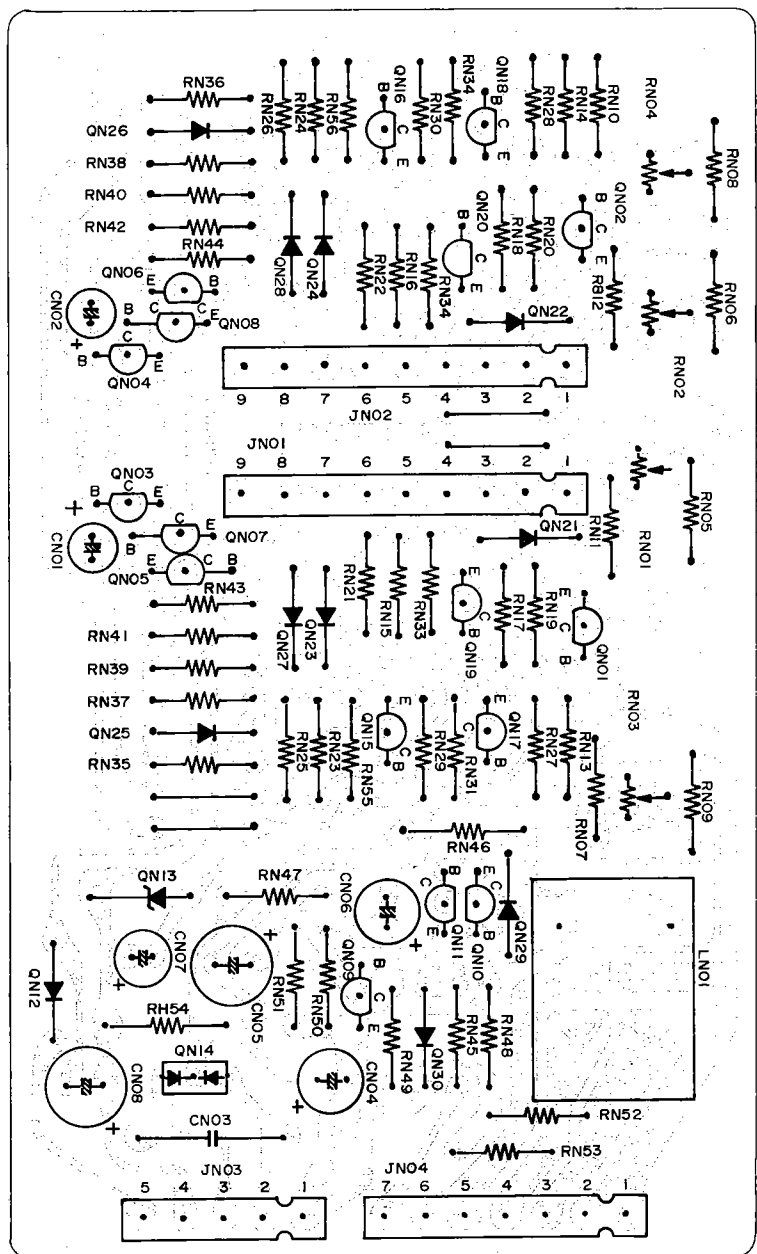
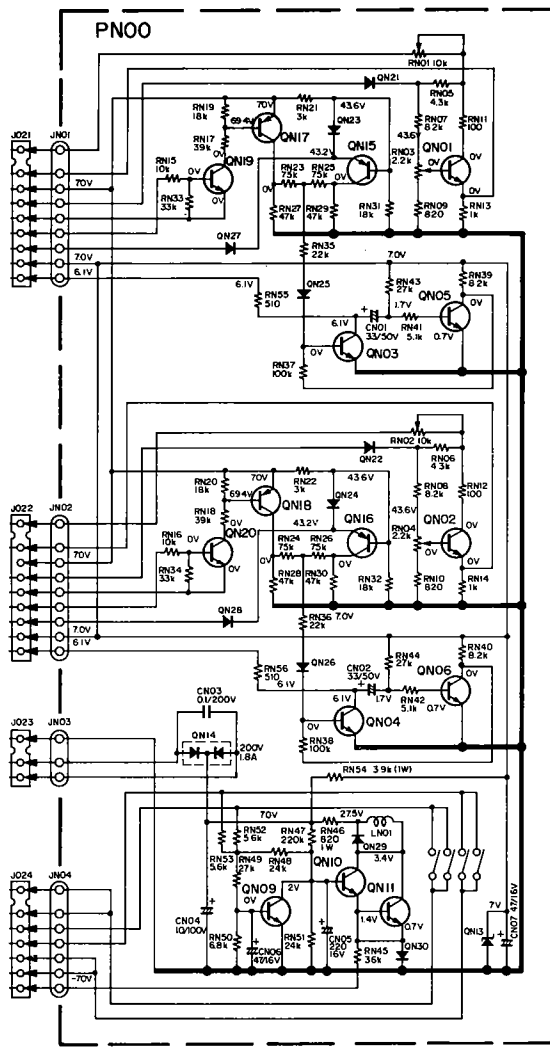

5.3 Power Supply Assembly (P800) Schematic Diagram and Component Locations

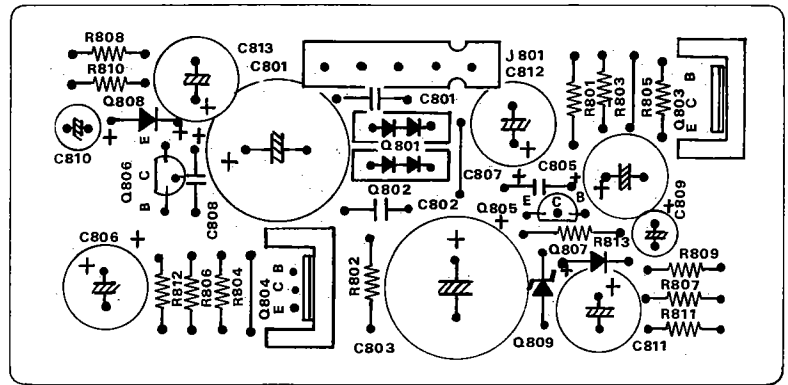
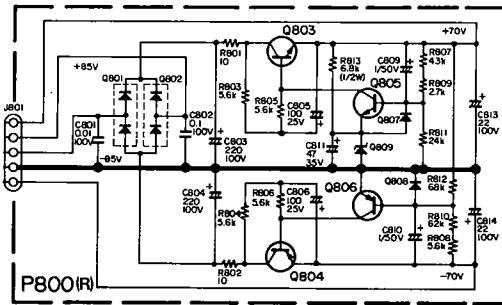

5.4 RCA Pin Terminal Assembly (PM00) Schematic Diagram and Component Locations

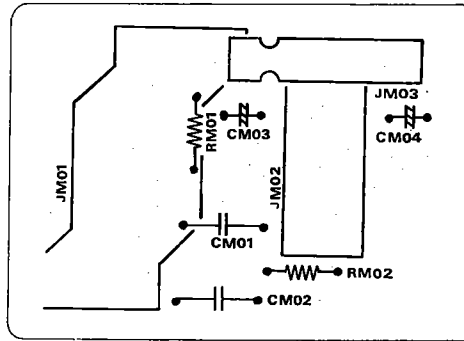
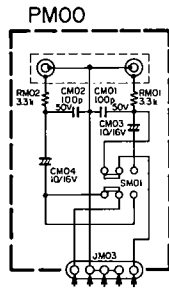

5.5 Meter Range Assembly (PS00) Schematic Diagram and Component Locations

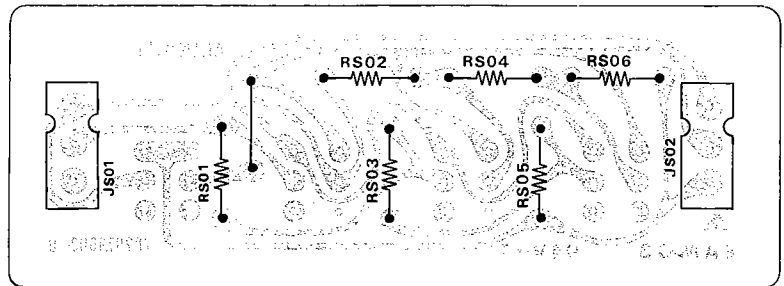
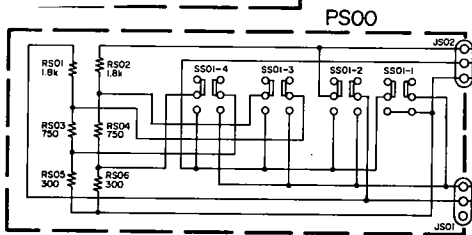

5.6 Fuse Assembly (PP00) Schematic Diagram and Component Locations

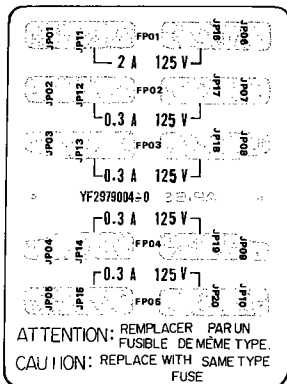

For (U) (C)

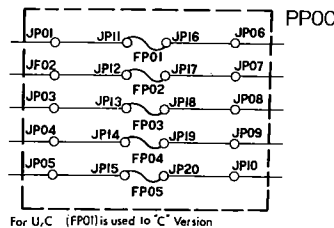

For U,C (FP01 is used to "C" Version)

For (N)

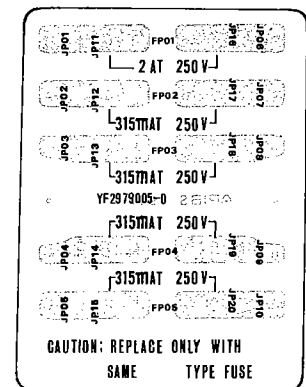

6. BLOCK DIAGRAM

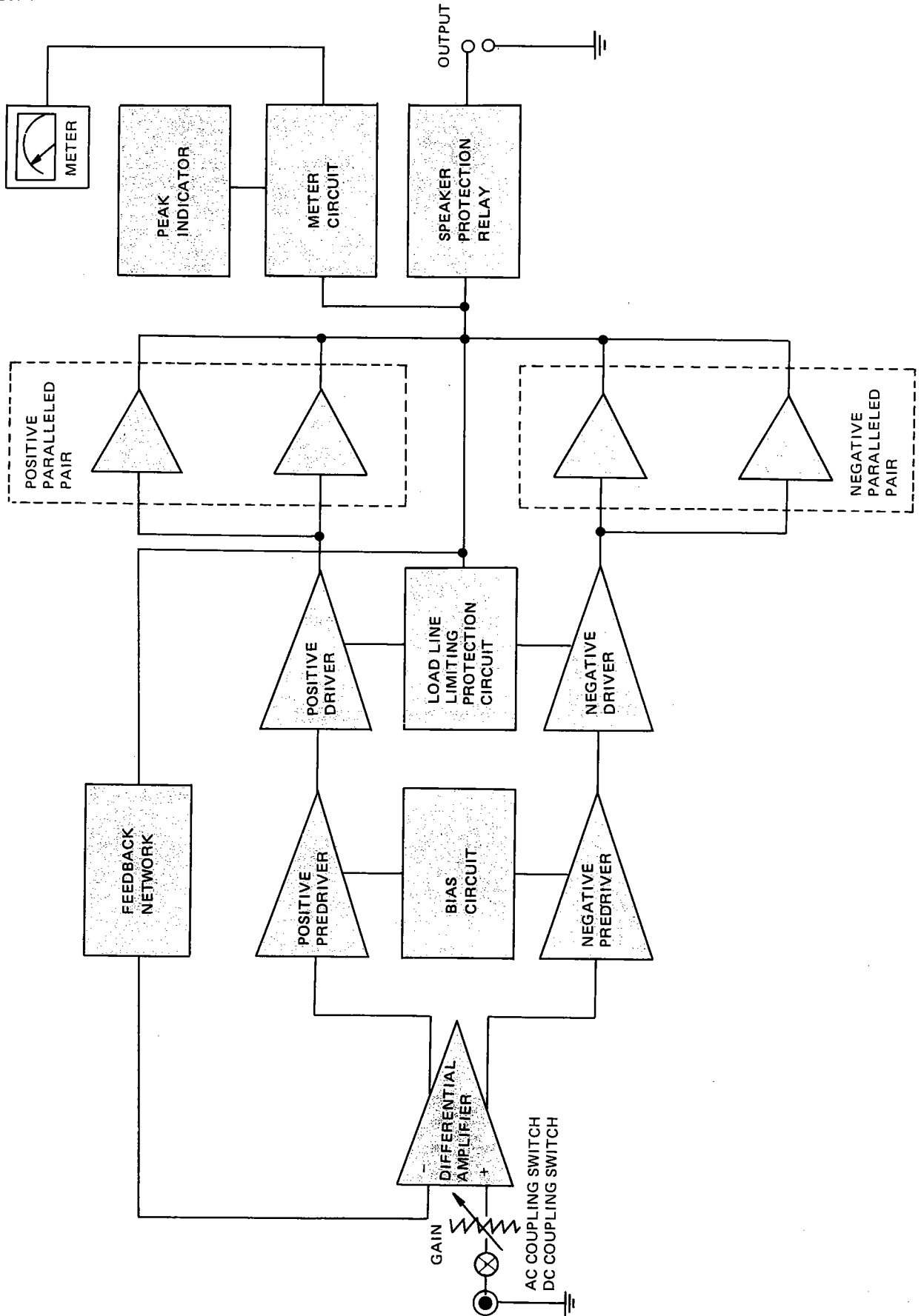

PLODED VIEW PARTS LIST
01-99] Front Panel

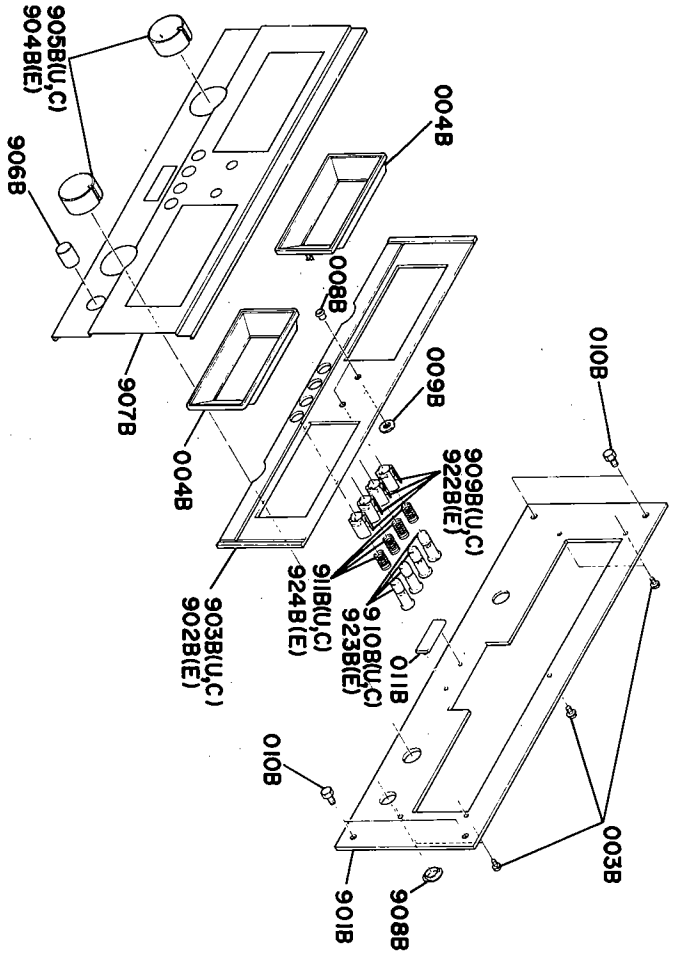

U : for U.S.A.
C : for Canada
E : for Europe

QTY	PART NO.	DESCRIPTION	REF. DESIG.		
			U	C	E
1	2979063400	Front Panel Assembly			
5	51480306A9	F. Washer Screw F3 x 6			
2	2979401010	Frame			
2	2979259022	Bushing			
2	64020600C0	RG Ring, CS Type			
1	2979251020	Badge			
1	2979063010	Escutcheon			
1	2979063025	Escutcheon			
1	2979063110	Escutcheon			
1	2979063025	Escutcheon			
1	2978259010	Bushing			
4	2979259010	Bushing			

REF. DESIG.	QTY	PART NO.	DESCRIPTION	REF. DESIG.		
				U	C	E
010B	4	52017069J0	H. Head Bolt			
904B	4	2979154010	Knob			
905B	2	2979154010	Knob			
906B	1	2970154030	Knob			
907B	1	2979053112	Cover			
910B	4	2979154020	Knob			
911B	4	2979115010	Spring			
923B	4	2979154020	Knob			
924B	4	2979115010	Spring			

[C02-99] Lid

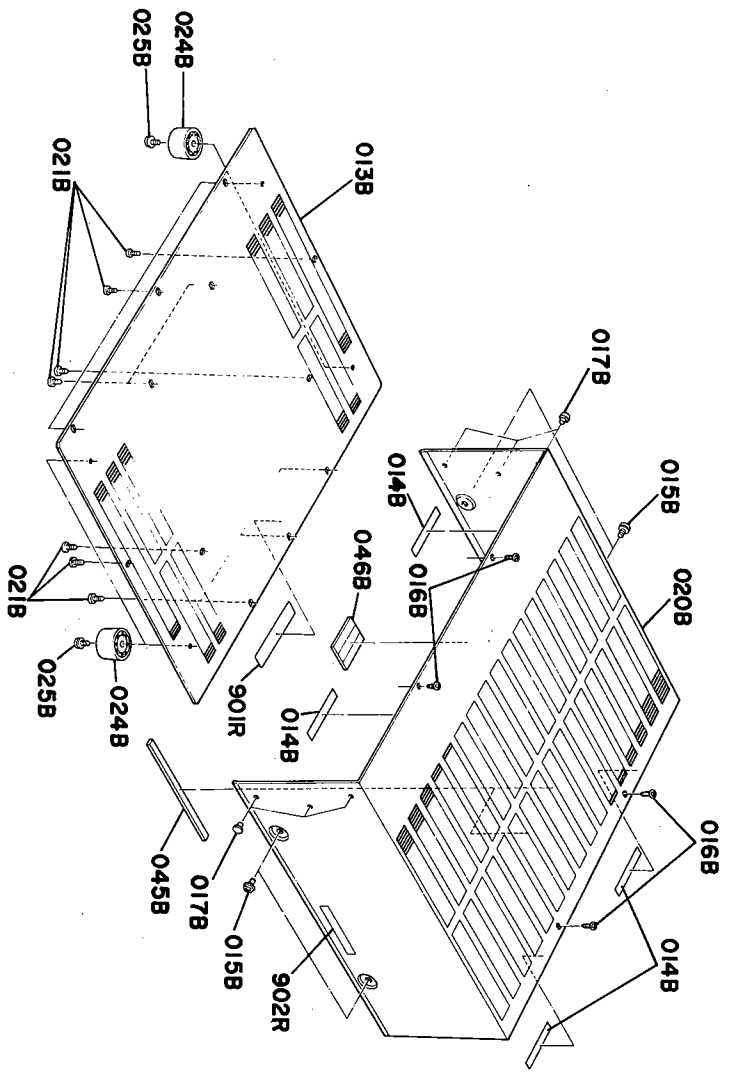

U : for U.S.A.
C : for Canada
E : for Europe

REF. DESIG.	QTY	PART NO.	DESCRIPTION	REF. DESIG.		
				U	C	E
013B	1	2963257010	Lid			
014B	4	2965118010	Spacer			
015B	4	51480406S9	F. Washer Screw F4 x 6			
016B	4	51280308U0	B.H.TAP. Screw B3 x 8			
017B	6	2991259010	Bushing			
020B	1	2979257010	Lid			
021B	12	51280410U0	B.H.TAP. Screw B4 x 10			
024B	4	2759057010	Leg			
025B	4	51570410S0	P.TAPT. Screw P4 x 10			
045B	2	2979056010	Buffer			

REF. DESIG.	QTY	PART NO.	DESCRIPTION	REF. DESIG.		
				U	C	E
046B	1	2979056200	Buffer			
901R	1	2578861010	Label			
901R	1	2911861110	Label			
902R	1	2911861143	Label			
902R	1	2932861010	Label			

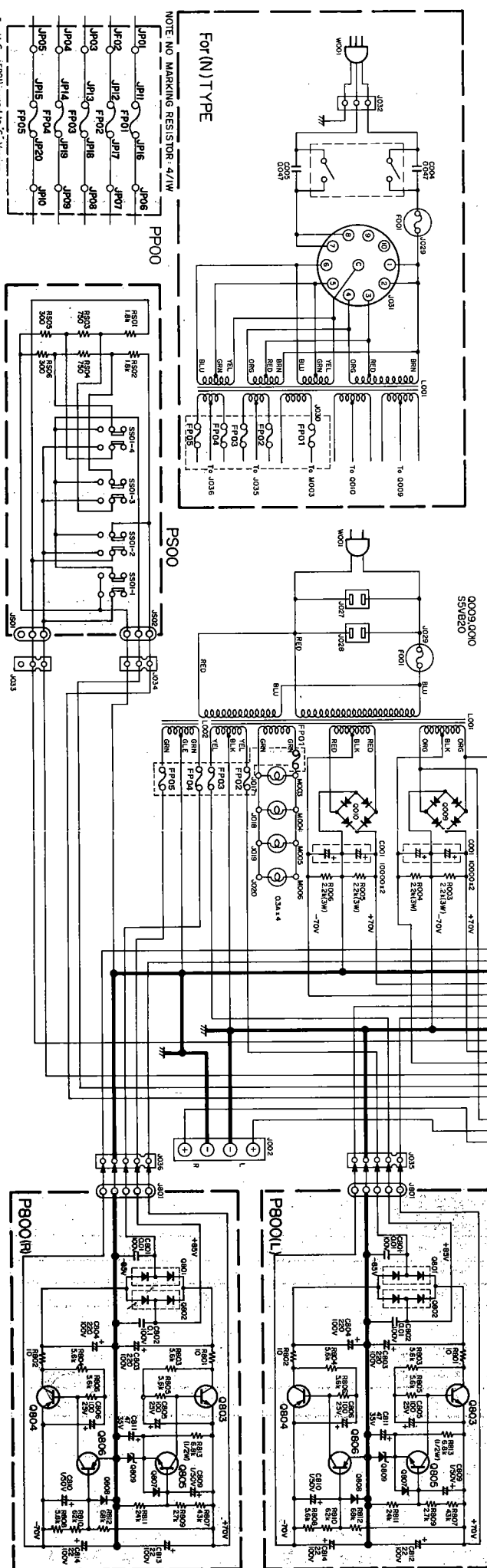
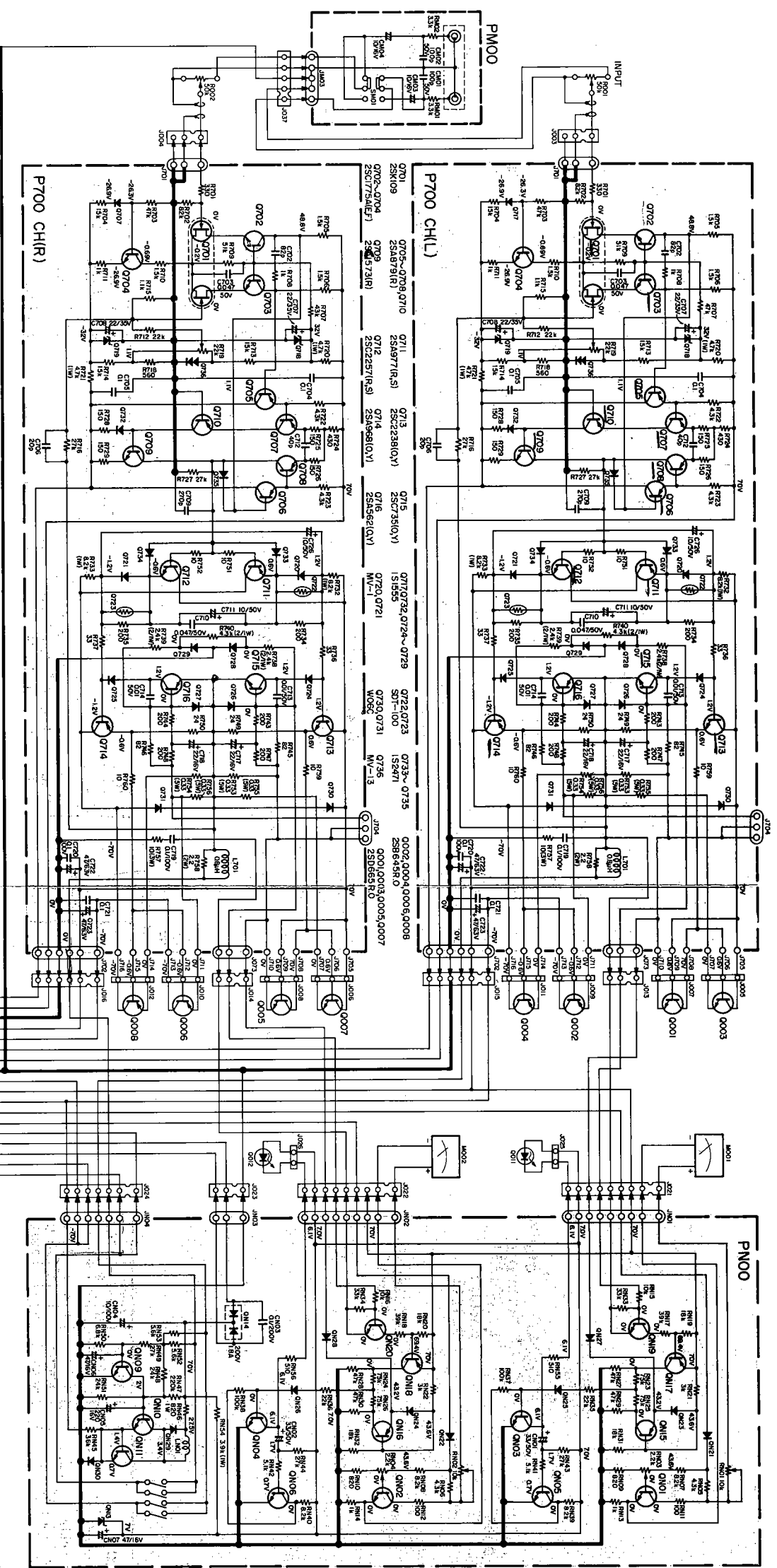

NOTE: NO MARKING RESISTOR 4/1W

For U.C. (FP01) is used to C Version

- Q801, Q802
- Q803
- Q804
- Q805
- Q806
- Q807, Q808
- Q809
- W2280

- Q702-Q710
- Q711, Q712
- Q713, Q714
- Q701

Q801-Q808, Q809
 Q810-Q811
 Q812-Q815
 Q816-Q818
 Q819, Q820
 Q821, Q822
 Q823-Q826
 Q827, Q828
 W00C
 Q829, Q830
 Q831
 Q832, Q833
 Q834

TRANSISTOR CONNECTION
 (BOTTOM VIEW)
 B. BASE
 C. COLLECTOR
 E. EMITTER

[P01-99] Front Chassis and General Parts

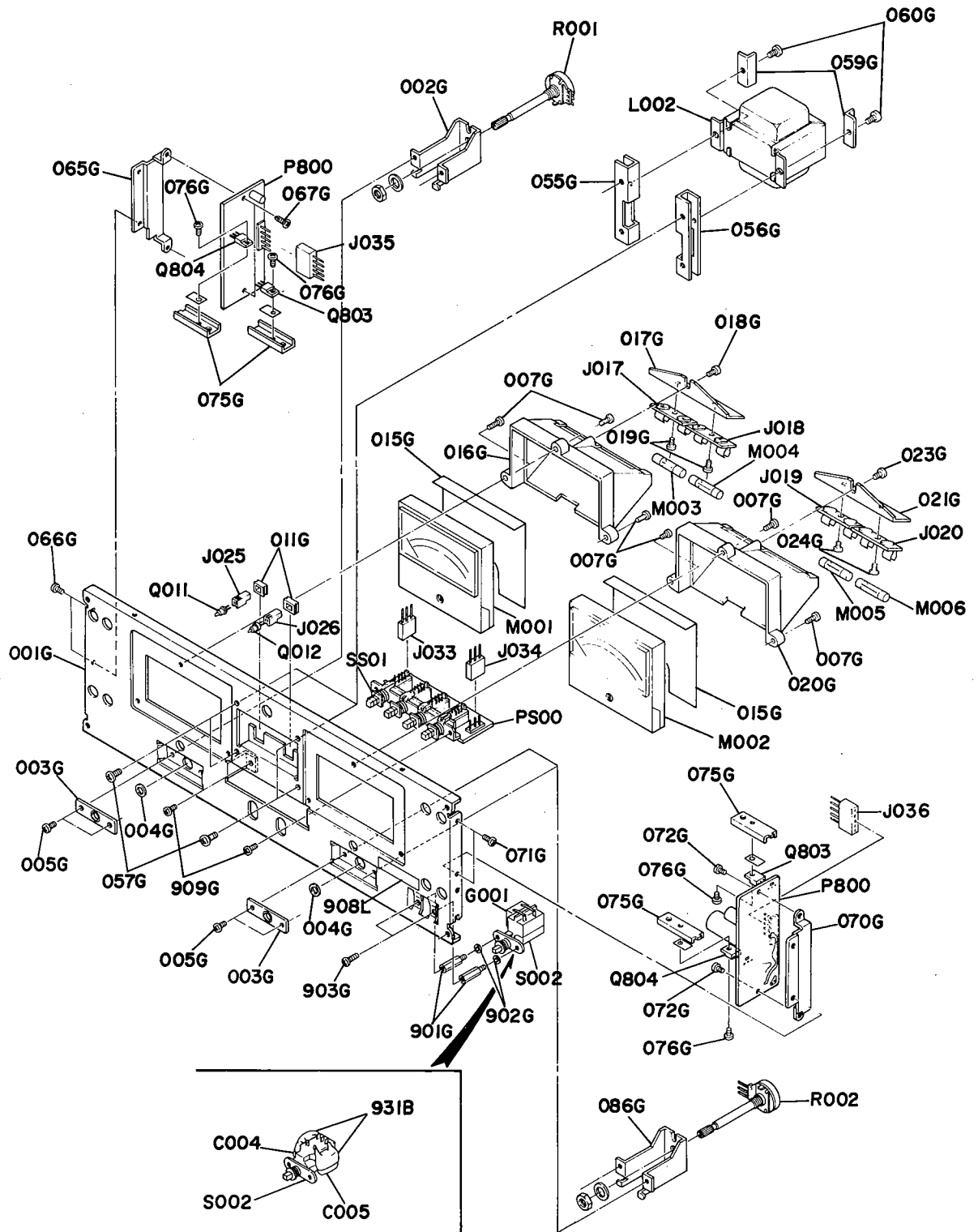

U : for U.S.A.
 C : for Canada
 E : for Europe

REF. DESIG.	Q'TY			PART NO.	DESCRIPTION
	U	C	N		
001G	1	1	1	2965160010	Bracket (Main Shassi)
002G	1	1	1	2965160020	Bracket
003G	2	2	2	2979160030	Bracket
004G	2	2	2	2891004020	Table
005G	4	4	4	51100306A9	B.H.M. Screw B3 x 6
007G	6	6	6	51300308B0	P.H. TAP. Screw B3 x 8
011G	2	2	2	2978259060	Bushing
015G	2	2	2	2931107020	Sheet
016G	1	1	1	2931274013	Reflector
017G	1	1	1	2931160050	Bracket
018G	1	1	1	51208308B0	B.H. TAP. Screw B3 x 8
019G	2	2	2	51100305A9	B.H.M. Screw B3 x 5
020G	1	1	1	2931274013	Reflector
021G	1	1	1	2931160050	Bracket
023G	1	1	1	51280308B0	B.H. TAP. Screw B3 x 8
024G	2	2	2	51100305A9	B.H.M. Screw B3 x 5
055G	1	1	1	2979160080	Bracket
056G	1	1	1	2979160090	Bracket
057G	4	4	4	51100406A9	B.H.M. Screw B4 x 6
059G	2	2	2	2979005010	Clamper
060G	2	2	2	51100408A9	B.H.M. Screw B4 x 8
065G	1	1	1	2979160080	Bracket
066G	2	2	2	51100306A9	B.H.M. Screw B3 x 6
067G	2	2	2	51280308B0	B.H. TAP. Screw B3 x 8
070G	1	1	1	2979160070	Bracket
071G	2	2	2	51100306A9	B.H.M. Screw B3 x 6
072G	2	2	2	51280308B0	B.H. TAP. Screw B3 x 8
075G	4	4	4	2947267050	Heatsink
076G	4	4	4	51100308A9	B.H.M. Screw B3 x 8
086G	1	1	1	2965160020	Brackct
901G	2	2	2	2965101010	Support
902G	2	2	2	54040302N0	Spring Washer
903G	2	2	2	51100305A9	B.H.M. Screw B3 x 5
909G	2	2	2	51100305A9	B.H.M. Screw B3 x 5
908L	1			2991861010	Label
931B			2	3926120010	Insulator
Q011	1	1	1	H110004030	L.E.D., LED132B
Q012	1	1	1	H110004030	L.E.D., LED132B

REF. DESIG.	Q'TY			PART NO.	DESCRIPTION
	U	C	N		
C004			1	DF17223800	Film Cap, 0.022 μ F, \pm 20%, 1000V
C005			1	DF17223800	Film Cap, 0.022 μ F, \pm 20%, 1000V
G001	1			BF10400040	Cap. Comp., 0,1 μ F + 1200HM
G001		1		BF33300020	Cap. Comp., 0.003 μ F + 1200HM
J017	1	1	1	YJ08000190	Jack
J018	1	1	1	YJ08000190	Jack
J019	1	1	1	YJ08000190	Jack
J020	1	1	1	YJ08000190	Jack
J025	1	1	1	YJ05000250	Jack
J026	1	1	1	YJ05000250	Jack
J033	1	1	1	YJ06001040	Jack
J034	1	1	1	YJ06001040	Jack
J035	1	1	1	YJ06001050	Jack
J036	1	1	1	YJ06001050	Jack
L002	1	1		TS15708020	Power Transformer
L002			1	TS15708030	Power Transformer
M001	1	1	1	IM11082060	D.C. Meter
M002	1	1	1	IM11082060	D.C. Meter
M003	1	1	1	IM10080430	Lamp, 8V, 300mA
M004	1	1	1	IM10080430	Lamp, 8V, 300mA
M005	1	1	1	IM10080430	Lamp, 8V, 300mA
M006	1	1	1	IM10080430	Lamp, 8V, 300mA
R001	1	1	1	RK05030200	Variable Resistor, 50K Ω (B)
R002	1	1	1	RK05030200	Variable Resistor, 50K Ω (B)
S002	1	1		SP01010240	Push Switch, Power
S002			1	SP02010250	Push Switch, Power
P800	2	2	2	YF29790020	P.W. Board, Power Supply
	2	2	2	ZZ29790020	P.W. Board Assembly
Q803	2	2	2	HT319132B0	Transistor, 2SC1913 (Q or R)
Q804	2	2	2	HT109132B0	Transistor, 2SA913 (Q or R)
PS00	1	1	1	YF29790030	P.W. Board, Meter Range
	1	1	1	ZZ29790030	P.W. Board Assembly
SS01	1	1	1	SP02040060	Push Switch

[P02-99] Main Chassis

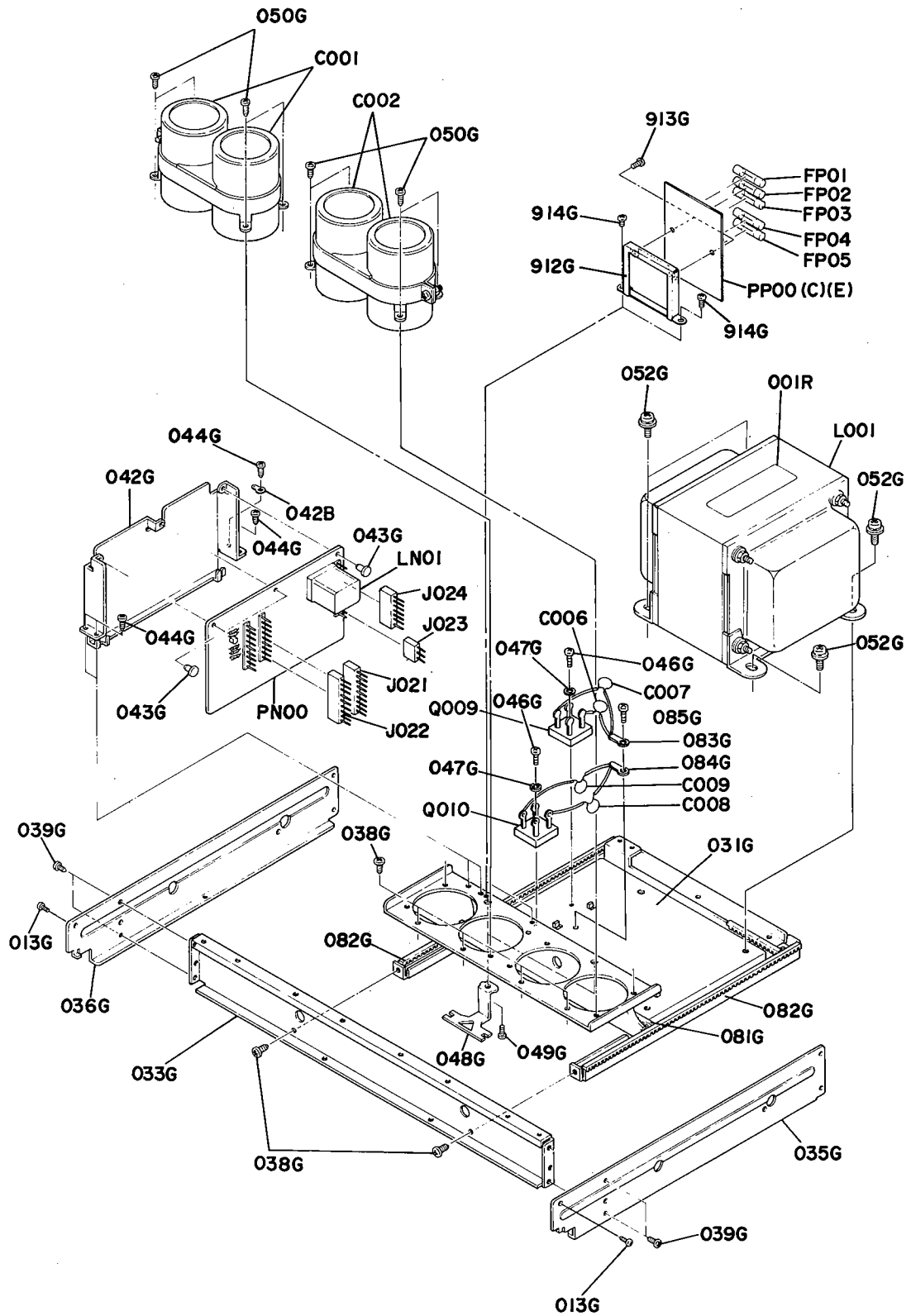

U : for U.S.A.
 C : for Canada
 E : for Europe

REF. DESIG.	Q'TY			PART NO.	DESCRIPTION
	U	C	N		
013G	2	2	2	51100306A9	B.H.M. Screw B3 x 6
031G	1	1	1	2979105014	Chassis
033G	1	1	1	2979126013	Stay
035G	1	1	1	2979105024	Chassis
036G	1	1	1	2979105034	Chassis
038G	6	6	6	51280408B0	B.H. TAP. Screw B4 x 8
039G	4	4	4	51280306B0	B.H. TAP. Screw B3 x 6
042G	1	1	1	2979160010	Bracket
043G	3	3	3	2965005010	Clamper
044G	4	4	4	51280306B0	B.H. TAP. Screw B3 x 6
046G	2	2	2	51280314B0	B.H. TAP. Screw
047G	2	2	2	5404302N0	Spring Washer
048G	2	2	2	2979160040	Bracket
049G	2	2	2	51280036B0	B.H. TAP. Screw B3 x 6
050G	8	8	8	51280306B0	B.H. TAP. Screw B3 x 6
052G	4	4	4	51490612A9	L. Washer Screw
081G	2	2	2	2218259020	Bushing
082G	2	2	2	2979259050	Bushing
083G	1	1	1	62030049W0	Lug
084G	1	1	1	62030049W0	Lug
085G	1	1	1	51280308B0	B.H. TAP. Screw B3 x 8
912G	1	1	1	2979160110	Bracket
913G	2	2	2	51280308B0	B.H. TAP. Screw B3 x 8
914G	2	2	2	51280308B0	B.H. TAP. Screw B3 x 8
042B	1	1	1	62030039W0	Lug
001R	1	1	1	2213861010	Label
C001	1	1	1	E110908040	Elect. Cap., 10000 μ F x 2, 80V
C002	1	1	1	E110908040	Elect. Cap., 10000 μ F x 2, 80V
C006	1	1	1	DK18103510	Ceramic Cap, 0.01 μ F, 500V
C007	1	1	1	DK18103510	Ceramic Cap, 0.01 μ F, 500V
C008	1	1	1	DK18103510	Ceramic Cap, 0.01 μ F, 500V
C009	1	1	1	DK18103510	Ceramic Cap, 0.01 μ F, 500V
L001	1	1		TS63303010	Power Transformer
L001			1	TS63303020	Power Transformer
Q009	1	1	1	HD20004290	Diode, S5VB-20
Q010	1	1	1	HD20004290	Diode, S5VB-20

REF. DESIG.	Q'TY			PART NO.	DESCRIPTION	
	U	C	N			
PN00	1	1	1	YG29650020	P.W. Board, Peak Ind.	
	1	1	1	ZZ29791020	P.W. Board Assembly	
J021	1	1	1	YJ06001070	Jack	
J022	1	1	1	YJ06001070	Jack	
J023	1	1	1	YJ06001040	Jack	
J024	1	1	1	YJ06001060	Jack	
LN01	1	1		LY20240110	Relay, MSJ24D2-0	
PP00	1	1		YF29790040	P.W. Board, Fuse	
	1	1		ZZ29790040	P.W. Board Assembly	
FP01			1	FS10200900	Fuse, 2A, 125V	
FP02			4	FS10030900	Fuse, 0.3A, 125V	
}						
FP05						
PP00			1	YF29790050	P.W. Board, Fuse	
			1	ZZ29790050	P.W. Board Assembly	
FP01			1	FS10200800	Fuse, 2AT	
FP02			4	FS10031800	Fuse, 351mAT	
}						
FP05						
JP01			10	10	YP10001200	Plug
}						
JP10						
JP11						
}			10	10	YP08000200	Plug
JP20						

[M01-99] Main Amp P.W. Doard and Heat-Sink

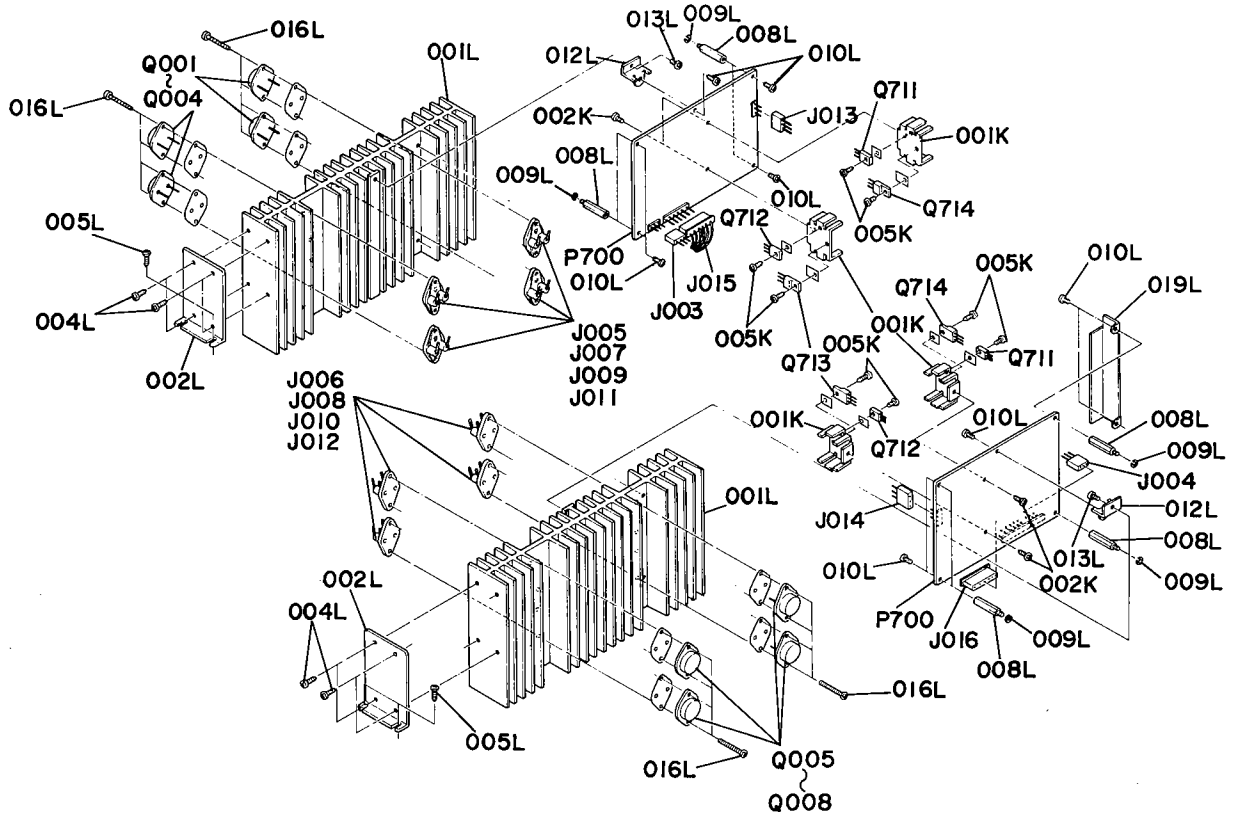

U : for U.S.A.
 C : for Canada
 E : for Europe

REF. DESIG.	Q'TY			PART NO.	DESCRIPTION
	U	C	N		
001K	4	4	4	2212267023	Heatsink
002K	4	4	4	51100306S9	B.H.M. Screw B3 x 6
005K	8	8	8	51282608U0	B.H. TAP. Screw B2.6 x 8
001L	2	2	2	2979267010	Heatsink
002L	2	2	2	2979160020	Bracket
004L	8	8	8	51280308B0	B.H. TAP. Screw B3 x 8
005L	4	4	4	51280306B0	B.H. TAP. Screw B3 x 6
008L	8	8	8	2979101010	Support
009L	8	8	8	54040302N0	Spring Washer
010L	10	10	10	51100306A9	B.H.M. Screw B3 x 6
012L	2	2	2	2979267020	Heatsink
013L	2	2	2	51100306A9	B.H.M. Screw B3 x 6
016L	16	16	16	51440316A9	L. Washer Screw
019L	1	1	1	2979109010	Shield
J003	1	1	1	YJ06001240	Jack
J004	1	1	1	YJ06001240	Jack
J005	1	1	1	YJ05000200	Jack
J006	1	1	1	YJ05000200	Jack
J007	1	1	1	YJ05000200	Jack
J008	1	1	1	YJ05000200	Jack

REF. DESIG.	Q'TY			PART NO.	DESCRIPTION
	U	C	N		
J009	1	1	1	YJ05000200	Jack
J010	1	1	1	YJ05000200	Jack
J011	1	1	1	YJ05000200	Jack
J012	1	1	1	YJ05000200	Jack
J013	1	1	1	YJ06001240	Jack
J014	1	1	1	YJ06001240	Jack
J015	1	1	1	YJ06001202	Jack
J016	1	1	1	YJ06001202	Jack
Q001	1	1	1	HT406652A0	Transistor, 2SD665 (O or R)
Q002	1	1	1	HT206452A0	Transistor, 2SB645 (O or R)
Q003	1	1	1	HT406652A0	Transistor, 2SD665 (O or R)
Q004	1	1	1	HT206452A0	Transistor, 2SB645 (O or R)
Q005	1	1	1	HT406652A0	Transistor, 2SD665 (O or R)
Q006	1	1	1	HT206452A0	Transistor, 2SB645 (O or R)
Q007	1	1	1	HT406652A0	Transistor, 2SD665 (O or R)
Q008	1	1	1	HT206452A0	Transistor, 2SB645 (O or R)
P700	2	2	2	YG29650040	P.W. Board, Main Amp.
	2	2	2	ZZ29791040	P.W. Board Assembly
Q711	2	2	2	HT109772R0	Transistor, 2SA977 (R or S)
Q712	2	2	2	HT322572R0	Transistor, 2SC2257 (R or S)
Q713	2	2	2	HT322382O0	Transistor, 2SC2238B (O or Y)
Q714	2	2	2	HT109682O0	Transistor, 2SA968B (O or Y)

U : for U.S.A.
 C : for Canada
 E : for Europe

REF. DESIG.	Q'TY			PART NO.	DESCRIPTION
	U	C	E		
PM00	1	1	1	YF29790010	PM00-TERMINAL CIRCUIT BOARD
	1	1	1	ZZ29790010	P.W. Board RCA Pin Terminal
	1	1	1		P.W. Board Assembly
CM01 CM02 CM03 CM04	1	1	1	DF65101010	PM00-CAPACITORS
	1	1	1	DF65101010	Film, 100PF, ±5%, 50V
	1	1	1	EQ10601610	Film, 100PV, ±5%, 50V
	1	1	1	EQ10601610	Elect, 10μF, 16V
RM01 RM02	1	1	1	GD05332140	Elect, 10μF, 16V
	1	1	1	GD05332140	PM00-RESISTORS
JM03 SM01	1	1	1	GD05332140	Resistor, 3.3KΩ, ±5%, 1/4W
	1	1	1	GD05332140	Resistor, 3.3KΩ, ±5%, 1/4W
PN00	1	1	1	YP06000580	PM00-MISCELLANEOUS
	1	1	1	SS02020380	Plug, 5P Connector
PN00	1	1	1	SS02020380	Slide Switch
	1	1	1	YG29650020	PN00-PEAK IND. SIRCUIT BOARD
CN01 CN02	1	1	1	ZZ29791020	P.W. Board, Peak Ind.
	1	1	1	ZZ29791020	P.W. Board Assembly
CN04 CN05 CN06 CN07	1	1	1	EA33505090	PN00-CAPACITORS
	1	1	1	EA33505090	Elect, 3.3μF, 50V
	1	1	1	EA10610090	Elect, 3.3μF, 50V
	1	1	1	EA22701690	Elect, 10μF, 100V
	1	1	1	EA47601690	Elect, 220μF, 16V
	1	1	1	EA47601690	Elect, 47μF, 16V
	1	1	1	EA47601690	Elect, 47μF, 16V
RN01 RN02 RN03 RN04 RN05 RN06 RN07 RN08 RN09 RN10	1	1	1	RA01030390	PN00-RESISTORS
	1	1	1	RA01030390	(All Resistors are ±5% and 1/4W)
	1	1	1	RA02220080	Trimming, 10KΩ(B)
	1	1	1	RA02220080	Trimming, 10KΩ(B)
	1	1	1	RA02220080	Trimming, 2.2KΩ(B)
	1	1	1	RT05432140	Trimming, 2.2KΩ(B)
	1	1	1	RT05432140	4.3KΩ
	1	1	1	RT05432140	4.3KΩ
	1	1	1	RT05822140	8.2KΩ
	1	1	1	RT05822140	8.2KΩ
	1	1	1	RT05821140	820Ω
RN11 RN12 RN13 RN14 RN15 RN16 RN17 RN18 RN19 RN20	1	1	1	RT05101140	820Ω
	1	1	1	RT05101140	100Ω
	1	1	1	RT05101140	100Ω
	1	1	1	RT05102140	1KΩ
	1	1	1	RT05102140	1KΩ
	1	1	1	RT05103140	10KΩ
	1	1	1	RT05103140	10KΩ
	1	1	1	RT05393140	39KΩ
	1	1	1	RT05393140	39KΩ
	1	1	1	RT05183140	18KΩ
	1	1	1	RT05183140	18KΩ
RN21 RN22 RN23 RN24 RN25 RN26 RN27 RN28 RN29 RN30	1	1	1	RT05302140	3KΩ
	1	1	1	RT05302140	3KΩ
	1	1	1	RT05753140	75KΩ
	1	1	1	RT05753140	75KΩ
	1	1	1	RT05753140	75KΩ
	1	1	1	RT05753140	75KΩ
	1	1	1	RT05753140	75KΩ
	1	1	1	RT05473140	47KΩ
	1	1	1	RT05473140	47KΩ
	1	1	1	RT05473140	47KΩ
	1	1	1	RT05473140	47KΩ

REF. DESIG.	Q'TY			PART NO.	DESCRIPTION
	U	C	E		
RN31	1	1	1	RT05183140	18KΩ
RN32	1	1	1	RT05183140	18KΩ
RN33	1	1	1	RT05333140	33KΩ
RN34	1	1	1	RT05333140	33KΩ
RN35	1	1	1	RT05223140	22KΩ
RN36	1	1	1	RT05223140	22KΩ
RN37	1	1	1	RT05104140	100KΩ
RN38	1	1	1	RT05104140	100KΩ
RN39	1	1	1	RT05822140	82KΩ
RN40	1	1	1	RT05822140	82KΩ
RN41	1	1	1	RT05512140	5.1KΩ
RN42	1	1	1	RT05512140	5.1KΩ
RN43	1	1	1	RT05273140	27KΩ
RN44	1	1	1	RT05273140	27KΩ
RN45	1	1	1	RT05363140	36KΩ
RN46	1	1	1	GJ05821010	820Ω 1W
RN47	1	1	1	RT05224140	220KΩ
RN48	1	1	1	RT05243140	24KΩ
RN49	1	1	1	RT05273140	27KΩ
RN50	1	1	1	RT05682140	6.8KΩ
RN51	1	1	1	RT05243140	24KΩ
RN52	1	1	1	RT05562140	5.6KΩ
RN53	1	1	1	RT05562140	5.6KΩ
RN54	1	1	1	GJ05392010	3.9KΩ 1W
RN55	1	1	1	RT05511140	510Ω
RN56	1	1	1	RT05511140	510Ω
QN01	1	1	1	HT309452A0	PN00-SEMICONDUCTORS
QN02	1	1	1	HT309452A0	Transistor, 2SC945 (Q or R)
QN03	1	1	1	HT309452A0	Transistor, 2SC945 (Q or R)
QN04	1	1	1	HT309452A0	Transistor, 2SC945 (Q or R)
QN05	1	1	1	HT309452A0	Transistor, 2SC945 (Q or R)
QN06	1	1	1	HT309452A0	Transistor, 2SC945 (Q or R)
QN09	1	1	1	HT309452A0	Transistor, 2SC945 (Q or R)
QN10	1	1	1	HT313182B0	Transistor, 2SC131B (R or S)
QN11	1	1	1	HT313182B0	Transistor, 2SC131B (R or B)
QN13	1	1	1	HD30023090	Zener, WZ-071, 7V
QN14	1	1	1	HD20011030	Diode, DS131B, 200V
QN15	1	1	1	HT108722D0	Transistor, 2SA872A (D or E)
QN16	1	1	1	HT108722D0	Transistor, 2SA872A (D or E)
QN17	1	1	1	HT108722D0	Transistor, 2SA872A (D or E)
QN18	1	1	1	HT108722D0	Transistor, 2SA872A (D or E)
QN19	1	1	1	HT317752E0	Transistor, 2SC1775A (E or F)
QN20	1	1	1	HT317752E0	Transistor, 2SC1775A (E or F)
QN21	1	1	1	HD10001010	Diode, 1N34A
QN22	1	1	1	HD10001010	Diode, 1N34A
QN23	1	1	1	HD20001210	Diode, 1S2473
QN24	1	1	1	HD20001210	Diode, 1S2473
QN25	1	1	1	HD20001210	Diode, 1S2473
QN26	1	1	1	HD20001210	Diode, 1S2473
QN27	1	1	1	HD20011010	Diode, W06C
QN28	1	1	1	HD20011010	Diode, W06C
QN29	1	1	1	HD20005010	Diode, W06B
QN30	1	1	1	HD20005010	Diode, W06B

U : for U.S.A.
 C : for Canada
 E : for Europe

REF. DESIG.	Q'TY			PART NO.	DESCRIPTION
	U	C	E		
PN00-MISCELLANEOUS					
JN01	1	1	1	YP06001070	Plug, 9P, Connector
JN02	1	1	1	YP06001070	Plug, 9P, Connector
JN03	1	1	1	YP06001040	Plug, 3P, Connector
JN04	1	1	1	YP06001060	Plug, 7P, Connector
LN01	1	1	1	LY20240110	Relay, MSJ24D2-0
PS00-METER RANGE CIRCUIT BOARD					
PS00	1	1	1	YF29790030	P.W. Board, Meter Range
	1	1	1	ZZ29790030	P.W. Board Assembly
PS00-RESISTORS (All Resistors are ±5% and 1/4W)					
RS01	1	1	1	RT05182140	1.8KΩ
RS02	1	1	1	RT05182140	1.8KΩ
RS03	1	1	1	RT05751140	750Ω
RS04	1	1	1	RT05751140	750Ω
RS05	1	1	1	RT05301140	300Ω
RS06	1	1	1	RT05301140	300Ω
PS00-MISCELLANEOUS					
JS01	1	1	1	YP06001040	Plug, 3P, Connector
JS02	1	1	1	YP06001040	Plug, 3P, Connector
SS01	1	1	1	SP02040050	Push Switch
P700-MAIN AMP. CIRCUIT BOARD					
P700	1	1	1	YG29650040	B.W. Board, Main Amp.
	1	1	1	ZZ29771040	B.W. Board Assembly
P700-CAPACITORS					
C702	2	2	2	DD15820370	Ceramic, 82pF
C703	2	2	2	DF16473010	Film, 0.047μF, ±10%, 50V
C704	2	2	2	DF17104540	Film, 0.1μF, ±20%, 100V
C705	2	2	2	DF17104540	Film, 0.1μF, ±20%, 100V
C706	2	2	2	DD15200300	Ceramic, 20pF
C707	2	2	2	EA22603590	Elect, 22μF, 35V
C708	2	2	2	EA22603590	Elect, 22μF, 35V
C709	2	2	2	DD15271500	Ceramic, 270pF, ±5%, 500V
C710	2	2	2	DF16473010	Film, 0.047μF, ±10%, 50V
C712	2	2	2	DD15390330	Ceramic, 39pF
C713	2	2	2	DF16103010	Film, 0.01μF, ±10%, 50V
C714	2	2	2	DF16103010	Film, 0.01μF, ±10%, 50V
C717	2	2	2	EA22601690	Elect, 22μF, 16V
C718	2	2	2	EA22601690	Elect, 22μF, 16V
C719	2	2	2	DF17104540	Film, 0.1μF, ±20%, 100V
C720	2	2	2	DF17104540	Film, 0.1μF, ±20%, 100V
C721	2	2	2	DF17104540	Film, 0.1μF, ±20%, 100V
C722	2	2	2	EA22610090	Elect, 22μF, 100V
C723	2	2	2	EA22610090	Elect, 22μF, 100V
C726	2	2	2	EA10605090	Elect, 10μF, 50V

REF. DESIG.	Q'TY			PART NO.	DESCRIPTION
	U	C	E		
P700-RESISTORS (All Resistors are ±5% and 1/4W)					
R701	2	2	2	RT05331140	330Ω
R702	2	2	2	RT05823140	82KΩ
R703	2	2	2	RT05473140	47KΩ
R704	2	2	2	RT05153140	15KΩ
R705	2	2	2	GF05152140	1.5KΩ
R706	2	2	2	GF05152140	1.5KΩ
R707	2	2	2	RT05473140	47KΩ
R708	2	2	2	RT05102140	1KΩ
R709	2	2	2	RT05513140	51KΩ
R710	2	2	2	RT05152140	1.5KΩ
R711	2	2	2	RT05102140	1KΩ
R712	2	2	2	RT05223140	22KΩ
R713	2	2	2	RT05153140	15KΩ
R714	2	2	2	RT05153140	15KΩ
R715	2	2	2	RT02112140	1.1KΩ
R716	2	2	2	RT02273140	27KΩ
R718	2	2	2	RT05561140	560Ω
R719	2	2	2	RA02230050	Trimming, 22KΩ, CR29R
R720	2	2	2	GJ05472010	4.7KΩ, 1W
R721	2	2	2	GJ05222010	2.2KΩ, 1W
R722	2	2	2	GF05432140	4.3KΩ
R723	2	2	2	GF05432140	4.3KΩ
R724	2	2	2	GF05431140	430Ω
R725	2	2	2	GF05151140	150Ω
R726	2	2	2	GF05151140	150Ω
R727	2	2	2	RT05273140	27KΩ
R728	2	2	2	GF05151140	150Ω
R729	2	2	2	GF05151140	150Ω
R732	2	2	2	GJ05822010	8.2KΩ, 1W
R733	2	2	2	GJ05822010	8.2KΩ, 1W
R734	2	2	2	RT05151140	150Ω
R735	2	2	2	RT05151140	150Ω
R736	2	2	2	GF05330140	33Ω
R737	2	2	2	GF05330140	33Ω
R738	2	2	2	GF05242120	2.4KΩ
R739	2	2	2	GF05242120	2.4KΩ
R740	2	2	2	GF05432120	4.3KΩ
R743	2	2	2	GF05201140	200Ω
R744	2	2	2	GF05201140	200Ω
R745	2	2	2	GF05820140	820Ω
R746	2	2	2	GF05820140	820Ω
R747	2	2	2	GF05201140	200Ω
R748	2	2	2	GF05201140	200Ω
R749	2	2	2	GF05240120	24Ω, 1/2W
R750	2	2	2	GF05240120	24Ω, 1/2W
R751	2	2	2	RT05100140	10Ω
R752	2	2	2	RT05100140	10Ω
R753	2	2	2	GW10332050	0.33Ω, 5W
R754	2	2	2	GW10332050	0.33Ω, 5W
R755	2	2	2	GW10332050	0.33Ω, 5W
R756	2	2	2	GW10332050	0.33Ω, 5W
R757	2	2	2	GJ05100030	10Ω, 3W
R758	2	2	2	GJ05022020	2.2Ω, 2W
R759	2	2	2	RT05100140	100Ω
R760	2	2	2	RT05100140	100Ω

U : for U.S.A.
C : for Canada
E : for Europe

QTY	PART NO.	DESCRIPTION	REF. DESIG.			PART NO.	DESCRIPTION
			U	C	E		
2	HC100003200	P700-SEMICONDUCATORS IC: 2SK109 Dual FET IDSS (C or D)	P800			YF29790020	P800-POWER SUPPLY CIRCUIT BOARD P.W. Board, Power Supply
2	HT317752E0	Transistor, 2SC1775A (E or F)	C801	2	2	DK18103510	P800-CAPACITORS Ceramic, 0.01 μ F, 100V
2	HT317752E0	Transistor, 2SC1775A (E or F)	C802	2	2	DK18103510	Ceramic, 0.01 μ F, 100V
2	HT317752E0	Transistor, 2SC1775A (E or F)	C803	2	2	EA22710090	Elect., 220 μ F, 100V
2	HT108791R0	Transistor, 2SA879 R	C804	2	2	EA22710090	Elect., 220 μ F, 100V
2	HT108791R0	Transistor, 2SA879 R	C805	2	2	EA10702590	Elect., 100 μ F, 25V
2	HT108791R0	Transistor, 2SA879 R	C806	2	2	EA10702590	Elect., 100 μ F, 25V
2	HT108791R0	Transistor, 2SA879 R	C807	2	2	EA10510090	Elect., 1 μ F, 100V
2	HT108791R0	Transistor, 2SA879 R	C809	4	4	EA10510090	Elect., 1 μ F, 100V
2	HT315731R0	Transistor, 2SC1573 R	C810	4	4	EA47603590	Elect., 47 μ F, 35V
2	HT108791R0	Transistor, 2SA879 R	C811	2	2	EA22610090	Elect., 22 μ F, 100V
2	HT108791R0	Transistor, 2SA879 R	C812	2	2	EA22610090	Elect., 22 μ F, 100V
2	HT109772R0	Transistor, 2SA977 (R or S)	C813	2	2	EA22610090	Elect., 22 μ F, 100V
2	HT322572R0	Transistor, 2SC2257 (R or S)	R801	2	2	GF05100140	P800-RESISTORS (All Resistors are \pm 5% and 1/4W)
2	HT322382D0	Transistor, 2SC2238B (O or Y)	R802	2	2	GF05100140	10 Ω
2	HT109682D0	Transistor, 2SA968B (O or Y)	R803	2	2	GD05562140	5.6K Ω
2	HT307352B0	Transistor, 2SC735 (O or Y)	R804	2	2	GD05562140	5.6K Ω
2	HT105622B0	Transistor, 2SA562 (O or Y)	R805	2	2	GD05562140	5.6K Ω
2	HD20011050	Diode, 1S1555	R806	2	2	GD05562140	5.6K Ω
2	HD20011050	Diode, 1S1555	R807	2	2	GD05433140	43K Ω
2	HD20011050	Diode, 1S1555	R808	2	2	GD05562140	5.6K Ω
2	HD20011050	Diode, 1S1555	R809	2	2	GD05272140	2.7K Ω
2	HD20011050	Diode, 1S1555	R810	2	2	GD05623140	62K Ω
2	HD20011050	Diode, W06C	R811	2	2	GD05243140	24K Ω
2	HD20011050	Diode, W06C	R812	2	2	GD05683140	68K Ω
2	HD20011010	Diode, W06C	R813	2	2	GF05682120	6.8K Ω
2	HD20011010	Diode, W06C	O801	2	2	HD20013030	P800-SEMICONDUCATORS Diode, DS133B
2	HD20011050	Diode, 1S1555	O802	2	2	HD20013030	Diode, DS133B
2	HD20003210	Diode, 1S2471	O803	2	2	HT319132B0	Transistor, 2SC1913 (Q or R)
2	HD20003210	Diode, 1S2471	O804	2	2	HT109132B0	Transistor, 2SA 913 (Q or R)
2	HD20003210	Diode, 1SR34-200	O805	2	2	HT317752D0	Transistor, 2SC1775A (D or E)
2	HV000003210	Varistor, MV-13	O806	2	2	HT108722D0	Transistor, 2SA872A (D or E)
2	YP060001040	Plug, 3P, Connector	O807	2	2	HD20011050	Diode, 1S1555
2	YP06000540	Plug, 6P, Connector	O808	2	2	HD20011050	Diode, 1S1555
2	YP06001040	Plug, 3P, Connector	O809	2	2	HD30039090	Zener, OZ 24V
2	YP10001130	Plug, Raping Pin	J801	2	2	YP06001050	Plug, 5P, Connector
2	YP10001130	Plug, Raping Pin					
2	YP10001130	Plug, Raping Pin					
2	YP10001130	Plug, Raping Pin					
2	YP10001130	Plug, Raping Pin					
2	YP10001130	Plug, Raping Pin					
2	YP10001130	Plug, Raping Pin					
2	YP10001130	Plug, Raping Pin					
2	YP10001130	Plug, Raping Pin					
2	YP10001130	Plug, Raping Pin					
2	YP10001130	Plug, Raping Pin					
2	YP10001130	Plug, Raping Pin					
2	LL23915120	Coil, Choke Coil					

(W01-99)	Assembly and Wiring
(T01-99)	Adjustment
(X01-00)	Correction

[H01-99] Packing Materials

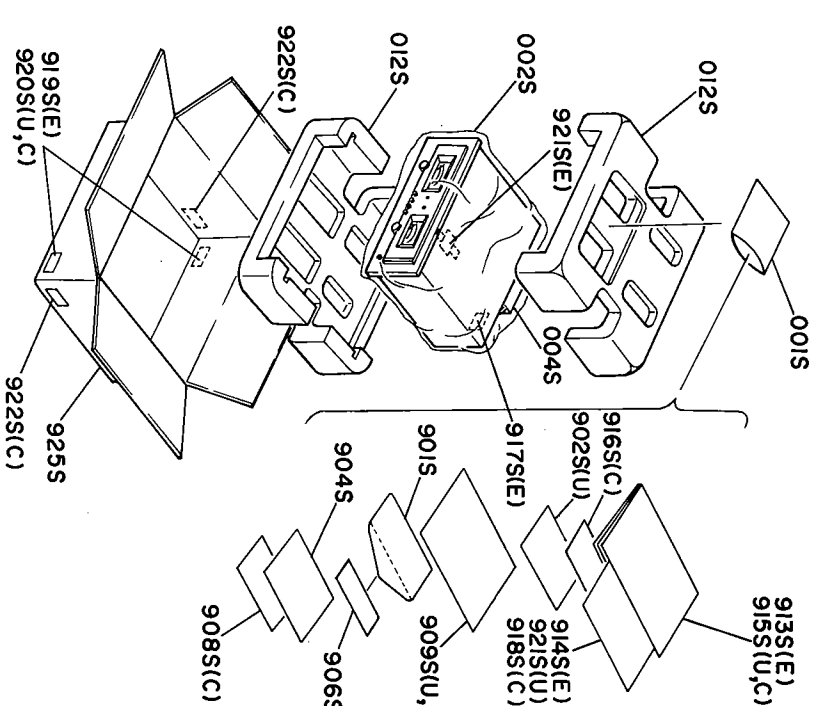

U : for U.S.A.
C : for Canada
E : for Europe

REF. DESIG.	QTY			PART NO.	DESCRIPTION
	U	C	E		
001S	1	1	1	9013025010	Polyethy Bag
002S	1	1	1	9014538350	Polyethy Bag
004S	1	1	1	2864804010	Sleeve
012S	2	2	2	2963809020	Cushion
901S	1	1	1	2577813010	Envelope
901S	1	1	1	2963809020	Envelope
901S	1	1	1	2818813010	Envelope
902S	1	1	1	2225813010	Envelope
904S	1	1	1	2577851020	Envelope
904S	1	1	1	2818851120	Instructions
906S	1	1	1	2577854010	Instructions
906S	1	1	1	9630000180	Guarantee Card
908S	1	1	1	9650000050	Guarantee Card
909S	1	1	1	2818854020	Guarantee Card
909S	1	1	1	2818854040	Guarantee Card

REF. DESIG.	QTY			PART NO.	DESCRIPTION
	U	C	E		
913S	1	1	1	2979851310	Instructions
914S	1	1	1	2979851030	Instructions
915S	1	1	1	2979851010	Instructions
915S	1	1	1	2979851310	Instructions
916S	1	1	1	2886851100	Instructions
917S	1	1	1	9560000043	Hang Tag
918S	1	1	1	2979851050	Instructions
919S	1	1	1	9526019060	Serial No. Card
920S	4	4	4	9526019010	Serial No. Card
920S	4	4	4	9526019020	Serial No. Card
921S	1	1	1	2731821010	Silicagel
921S	1	1	1	2979851020	Instructions
922S	1	2	1	9510901020	Label
925S	1	1	1	2979801012	Packing Case

TECHNICAL SPECIFICATIONS

ATED POWER OUTPUT, MINIMUM CONTINUOUS AVERAGE POWER	152 WATTS
ER CHANNEL, BOTH CHANNELS DRIVEN	20 Hz to 20 KHz
WER BAND	0.03% (8 OHMS)
TAL HARMONIC DISTORTION	0.05% (4 OHMS)
Distortion (I.H.F. method, 60 Hz and 7 KHz mixed 4 : 1 at rated power output)	
mping Factor	0.03% (8 ohms)
stivity (at MAIN IN)	0.05% (4 ohms)
edance (at MAIN IN)	60 (8 ohms, 20 Hz)
quency Response for Power Amp only	1.5 V
er Requirements	20 Hz ~ 20 KHz, ±0.2 dB
ensions	120 V AC, 60 Hz
anel Width	416 mm (16-3/8 inches)
anel Height	146 mm (5-3/4 inches)
Depth	301 mm (11-7/8 inches)
ght	
Unit alone	20 kg (44 lbs)
acked for shipment	22 kg (48.4 lbs)



MARANTZ

MARANTZ CO., INC. · P. O. BOX 577 · CHATSWORTH, CALIFORNIA · 91311

A WHOLLY-OWNED SUBSIDIARY OF SUPERSCOPE INC., CHATSWORTH, CALIFORNIA · 91311

