

marantz.

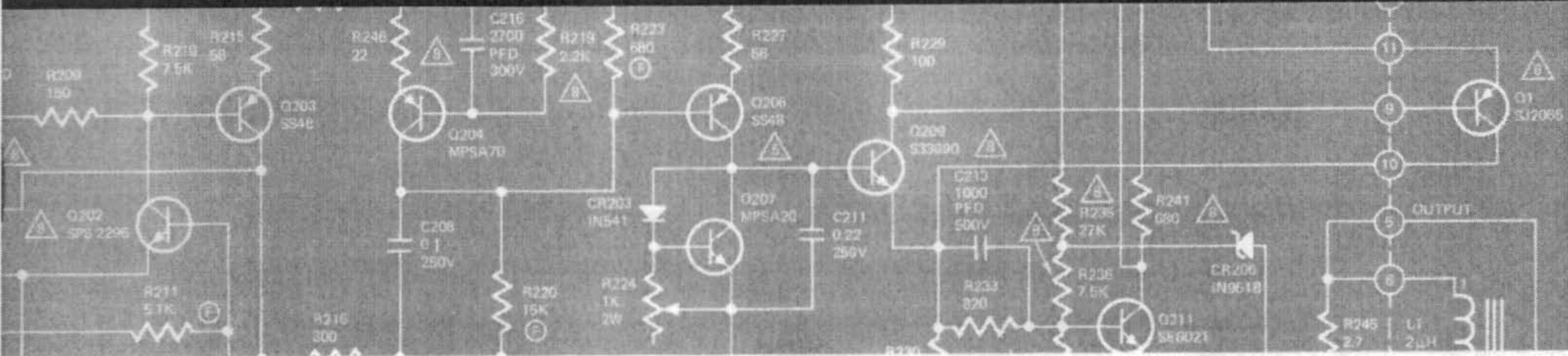

model thirty-two SERVICE MANUAL 32

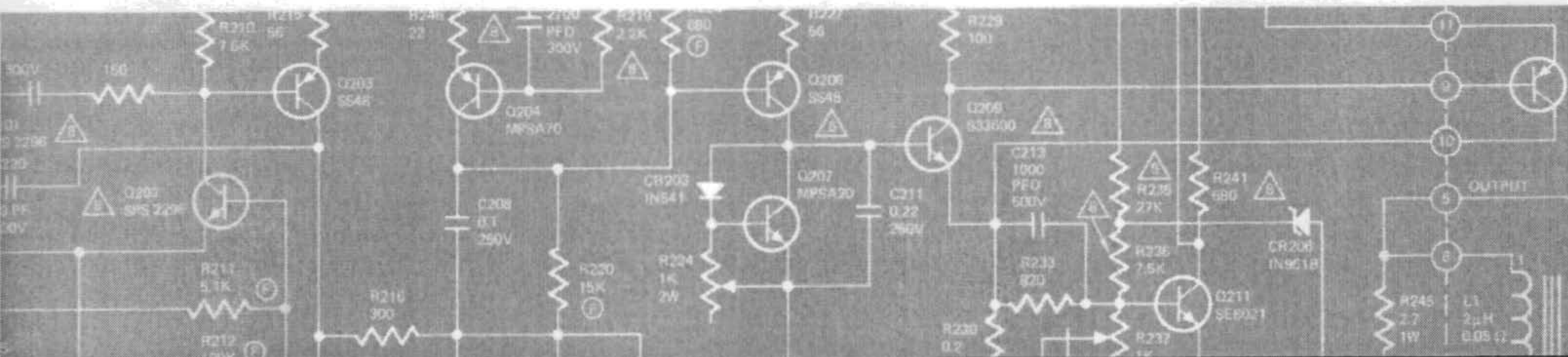

Stereo Console Amplifier

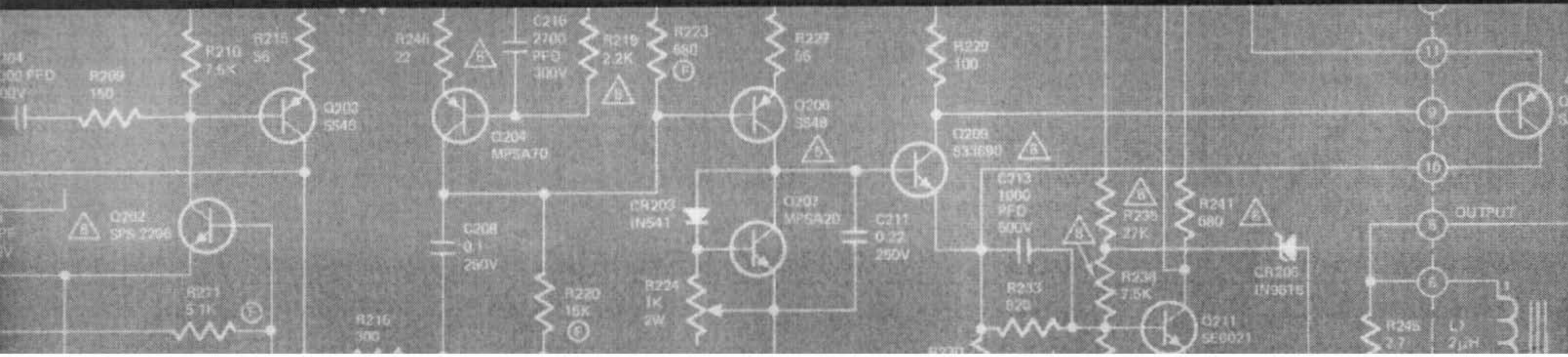

TABLE OF CONTENTS

| SECTION | PAGE |
|---------------------------|------|
| Introduction | 1 |
| Circuit Description | 1 |
| Technical Specifications | 6 |
| 240-Volt Conversion | 6 |
| Performance Verification | 8 |
| Trouble Analysis | 11 |
| Parts List | 13 |
| Component Layout Diagrams | 15 |
| Schematic | 18 |

LIST OF ILLUSTRATIONS

| FIGURE | | PAGE |
|--------|---|------|
| 1. | Amplifier Simplified Schematic | 2 |
| 2. | Rectifier/Relay Board Simplified Schematic | 4 |
| 3. | AC Power Control Box Simplified Schematic | 10 |
| 4. | Amplifier Output Load Box Simplified Schematic | 10 |
| 5. | Test Equipment Set-Up | 12 |
| 6. | Power Amplifier Board Component Assembly Diagram Revision 1 | 15 |
| 7. | Power Amplifier Board Component Assembly Diagram Revision 2 | 16 |
| 8. | Rectifier/Relay Board Component Assembly Diagram | 17 |
| 9. | Model 32 Schematic | 18 |

| TABLE | | PAGE |
|-------|---|------|
| 1. | Test Equipment Required for Servicing | 7 |

INTRODUCTION

This service manual is intended for use by authorized warranty stations. The manual contains service information for the Marantz Model 32 Stereo Power Amplifier, manufactured by the Marantz Company, a subsidiary of Superscope Incorporated, Sun Valley, California 91352.

Adjustment, maintenance, and troubleshooting information listed herein should be attempted only by the experienced technician, one knowledgeable in solid state amplifier operation and the use of test equipment. All instructions should be read carefully and understood fully before proceeding with any service.

Symptoms (and their remedies) listed in the troubleshooting section, are those which might occur in some units. As the Marantz Company becomes aware of other field problems, supplementary service bulletins will be issued to all stations. To improve this service, all problems (and their solutions) not covered in this service manual should be brought to the attention of the National Service Manager at our Sun Valley location.

CIRCUIT DESCRIPTION

The following circuit description will be based on Channel A only. Channel B operates in an identical manner.

AMPLIFIER

The input stage of the amplifier, Figure 1, comprises a differential amplifier (Q201, Q202), and an inverter. The inverter output is applied to the pre-drivers (Q206, Q208). DC balance between the two pre-drivers is maintained by the dynamic bias network comprising Q207, CR203, R224, and C211.

The output of the pre-drivers is applied to their respective drivers (Q209, Q210). The output from the drivers is applied to their respective power transistors (Q1, Q2).

Output current and voltage regulation are accomplished through a complex network. Excessive voltage levels are detected by Zener diodes CR206 and CR207. Excessive current levels are detected by resistors R230 and R231. Voltages developed by these components are applied to voltage-current (E-1) sensors Q211 and Q212.

When excessive levels are detected, Q211 and Q212 develop clipping signals. These signals are applied to E-1 controls Q204 and Q205. Thus, amplifier limiting is accomplished at approximately 70 watts into 8 ohms.

Feedback for the amplifier is developed at the junction of R230 and R231. The feedback is applied across two loops. Feedback applied across R225 and C210 completes the amplifier loop. Feedback applied across R212 and C206 completes the loop for the entire power amplifier section.

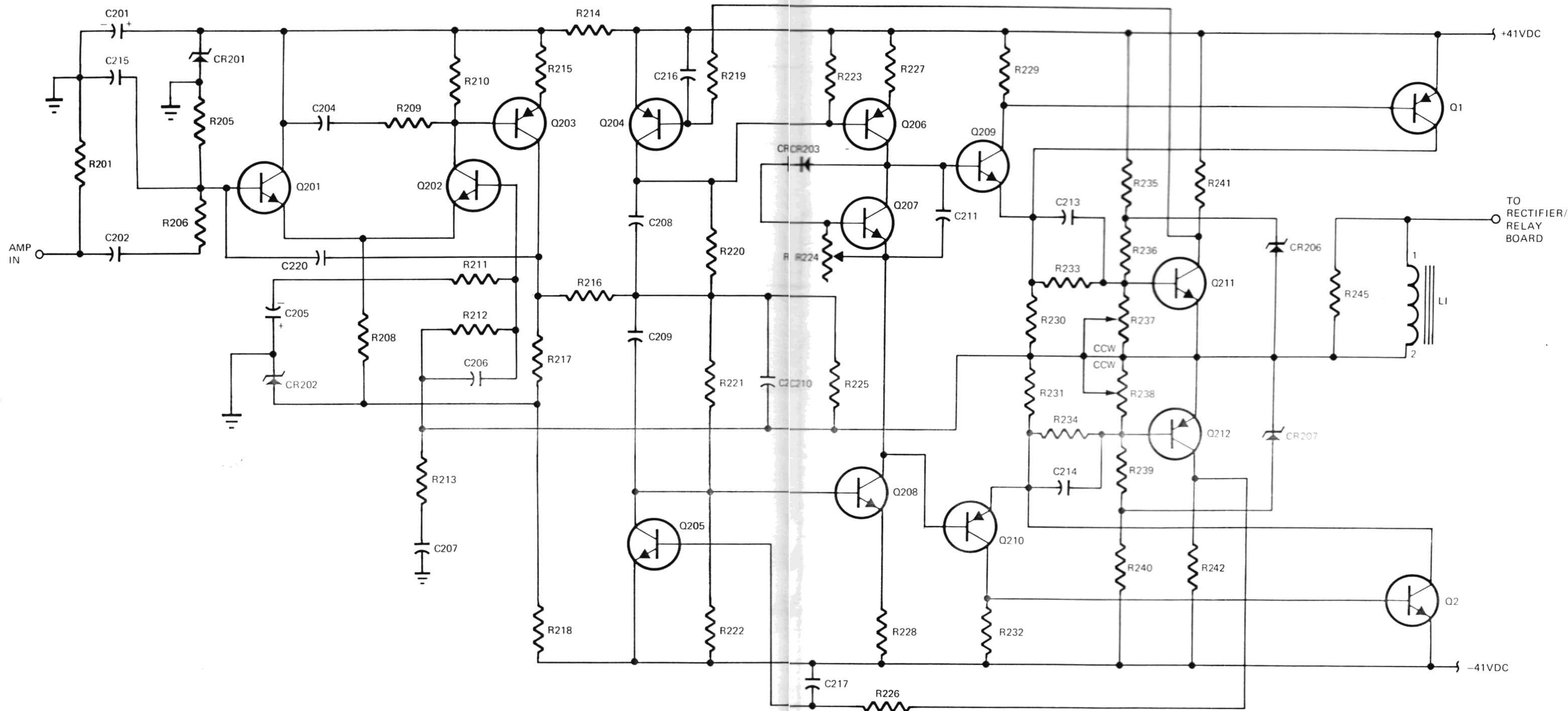

Figure 1. Amplifier Simplified Schematic.

RECTIFIER-RELAY BOARD

The output of the power amplifier is applied to the wipers of relay K301 on the rectifier relay board, Figure 2. Relay K301 energizes after a minimum delay of two seconds after turn on. The length of the delay is a factor of the time constant of R306, R309, and C302. This delay at turn-on is to prevent any transient surges from reaching the output terminals. Additionally, resistors R302 and R305 sample the audio output signals. Should a constant DC level over +4.5 volts, or a high amplitude signal below 10 Hz be present, Q301 will turn on, shorting the base of Q303 to ground. C302 begins to discharge and K301 de-energizes. If a constant DC level over -4.5 volts is present, the voltage drop across R304 bucks the voltage present at the base of Q303 and K301 de-energizes. The output from K301 is applied to the SPEAKER TERMINALS.

Sixty volts AC is applied to CR301 which develops the +41 and -41 volts for the power amplifier board. CR302 and CR303 develop the positive voltage to energize K301.

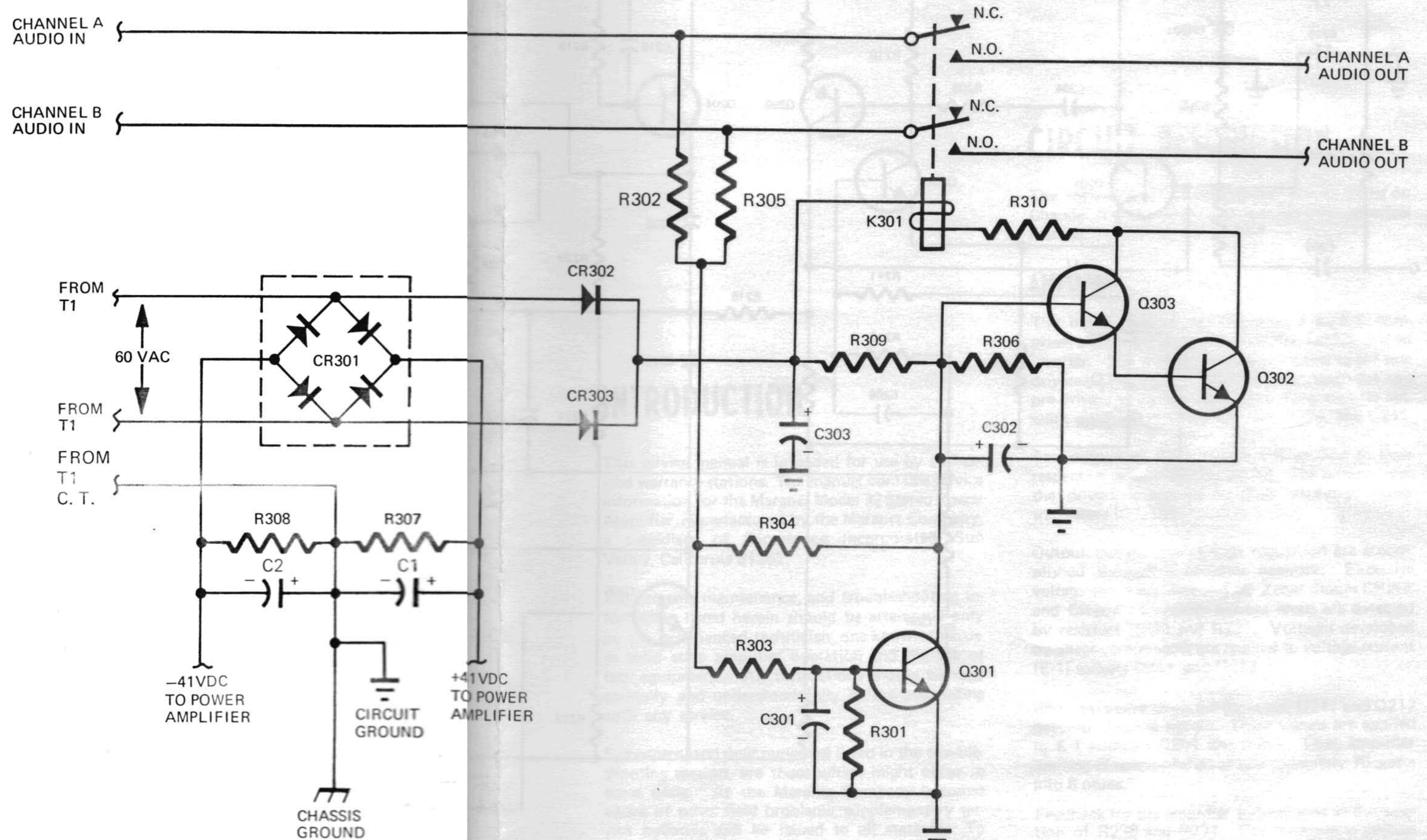

Figure 2. Rectifier/Relay Board Simplified Schematic.

TECHNICAL SPECIFICATIONS

Power Output (each channel, both channels driven, at rated distortion, 20 Hz to 20 KHz)

| Load | RMS | IHF |
|---------|-----|-----|
| 4 ohms | 60W | 90W |
| 8 ohms | 60W | 90W |
| 16 ohms | 30W | 45W |

Total Harmonic Distortion at or below rated power, 20 Hz to 20 KHz. less than 0.15%

Intermodulation Distortion at or below rated power, SMPTE, any combination of two frequencies, 20 Hz to 20 KHz: less than 0.15%

Frequency Response +0 -3 dB 3 Hz to 80 KHz, ±0.1 dB 20 Hz to 20 KHz

Input Sensitivity 1.0 Volt for rated power

Input Impedance 100K ohms

Damping Factor Greater than 100 at 8 ohms

GENERAL

Total Noise Better than 100 dB below rated power into 8 ohms

Power Requirements 120V AC, 250W, 50/60 Hz

Dimensions 15-3/8" w. x 5-3/4" h. x 9-5/8" deep

Unit Weight 21 pounds

Shipping Weight 27 pounds

240 volt AC Conversion

Split primary windings permit easy conversion from 120 volt to 240 volt operation.

240-VOLT AC CONVERSION

To convert the Model 32 to 240-volt operation, perform the following steps:

1. Remove the top cover.
2. Remove the remaining screws holding the right hand heatsink in place.
3. Remove the heatsink.
NOTE: Do not disconnect wires. Simply lay the heatsink next to the unit.
4. Using the 240-volt AC conversion kit, part number 103-1011-1, attach the standoff terminal, part number 359-1002, to the chassis (in the No. 6 hole between the transformer and the chassis edge) using the 6-32 x 1/8 screw supplied.

5. Unsolder the white wire from the fuse holder. Unsolder the black/white wire from J3 pin 2.
6. Solder the white and black/white wire to the standoff terminal.
7. Re-attach the heatsink and top cover.
8. Replace the 4 amp, 250V fuse in the unit with the 3 amp, 250V fuse, part number 451-1001, supplied with the conversion kit.
9. Remove the protective back from the caution label and place it on the top cover.

The Model 32 is now ready for 240-volt operation.

TEST EQUIPMENT REQUIRED FOR SERVICING

Table 1 lists the test equipment required for servicing the Model 32 Stereo Power Amplifier. The wattmeter, AC voltmeter, and variac may be assembled as a test fixture as shown schematically in Figure 3, and the load resistors and AC ammeter may be assembled into a second test fixture as shown in Figure 4.

| Item | Manufacturer and Model No. (or equivalent) | Use |
|---|--|--|
| Distortion Analyzer | Hewlett Packard, Model 331A or 333A | Measures distortion and voltage of amplifier output. |
| Audio Oscillator | Weston Model CVO-100P (NOTE : Less than 0.02 percent residual distortion is required.) | Sinewave and squarewave signal source. |
| Oscilloscope | Tektronix, Model 503; Data, Model 555 | Waveform analysis and troubleshooting |
| VTVM | RCA Senior Volt-Ohmyst, Model WV-98C | Voltage and resistance measurements. |
| AC Wattmeter | Simpson, Model 390 | Monitors primary power consumption of amplifier. |
| AC Ammeter (0 to 10 amps) | Commercial Grade | Monitors amplifier output under short circuit condition. |
| Line Voltmeter (0 to 150 vac) | Commercial Grade | Monitors potential of primary power to amplifier. |
| Variable Autotransformer (0 to 140 vac, 10 amps) | Powerstat, Model 116B | Adjusts level of primary power to amplifier. |
| Shorting Plug | Use phono plug with 600 ohms across center pin and shell. | Shorts amplifier input to eliminate noise pickup. |
| Power Supply Bleeder Resistor (10 ohms at 1 W) | Commercial Grade | Discharges power supply filter capacitors prior to disassembly or resistance measurements. |
| Output Load Resistor (8 \pm 0.5%, 250 W) | Commercial Grade | Provides 8-ohm load for amplifier output termination. |
| Output Load Resistor (4 \pm 0.5%, 250 W) | Commercial Grade | Provides 4-ohm load for amplifier output termination. |
| Output Load Capacitor (0.5 mfd) | Mylar | Provides capacitive load for instability checks. |
| AC Power Control Box | Optional Item. Fabricate in accordance with Figure 3. | Monitors and controls primary power for amplifier. |
| Amplifier Output Load Box | Optional item. Fabricate in accordance with Figure 4. | Provides various amplifier loads and can monitor shorted output. |

PERFORMANCE VERIFICATION

TEST PROCEDURE

A. Test Equipment

Refer to Table 1 for required test equipment.

B. Preliminary Procedures

1. Set up the test equipment as shown in Figure 5, with the instrument controls set in the following positions:

| | |
|--------------------------------|---------------|
| Line Switch | Off |
| Variable-Line Switch | Variable |
| Watt Meter Switch | On |
| Variac | 0 (Fully CCW) |
| Load — Resistive | Off |
| Load — Capacitive | Off |
| Scope Output | 5V Range |
| Scope Gain | Minimum |
| AC Voltmeter | 30V Range |
| Scope Vertical | 20 mv/cm |
| Scope Horizontal, Line Sync | 1 ms/cm |
| Scope Input | DC |
| Scope Trace (Input Shorted) | Centered |

2. Connections, between the output terminals of the Model 32 and the resistive load, must have negligible resistance with respect to the resistance of the load itself. Applicable resistance adds to the total load, resulting in inaccurate measurement of output power.
3. Insert a shorting plug in each input jack of the Model 32.
4. Remove the top cover of the Model 32.

C. DC Balance Test

1. Connect oscilloscope to Channel A output terminals of the Model 32.
2. Turn Line Switch to ON and adjust variac to 120 vac.

3. After relay energizes, adjust Channel A (Left Hand Heatsink) amplifier board potentiometer for an indication of a "line" zero (i.e., $0V \pm 50$ mv) as indicated on the oscilloscope.

4. Repeat test for Channel B (Right Hand Heatsink).

D. Total Hum and Noise Test

1. Connect the voltmeter across the Channel A output terminals of the Model 32.
2. With shorting plugs in the input jacks, the meter should read 0.5 mv or less.
3. Repeat test for Channel B.
4. Turn Line Switch to OFF and adjust variac to 0 (fully CCW).

E. Bias Adjustment Test

1. Preset the bias adjust potentiometer R224 on each amplifier board fully CCW.
2. After discharging the filter capacitors using the bleeder resistor, disconnect all red and blue wires from the capacitor terminals.
3. Turn Line Switch to ON and slowly advance variac while observing the voltmeter and wattmeter. The relay K301 should energize at 105 volts or less.
4. Turn Line Switch to OFF. Reconnect all red and blue wires to filter capacitors.
5. Turn Line Switch to ON and advance variac to 120 volts.
6. Observe wattmeter reading. Adjust the Channel A amplifier board potentiometer R224 to increase wattmeter reading to a point halfway between the initial reading and 20 watts.
7. Adjust the Channel B amplifier board potentiometer R224 to increase wattmeter reading to 20 watts.
8. Turn the Line Switch to OFF. Remove shorting plugs from the input jacks.

NOTE: AC line voltage must be maintained at 120 volts at all times during remaining tests.

F. Maximum Power Output

1. Connect the audio oscillator to the input jacks of the Model 32. Set the audio oscillator frequency to 20 KHz.
2. Connect the distortion analyzer across the Channel A output load (4 ohms), set the analyzer on the 30 vac scale.
3. Turn the amplifier board potentiometers R237 and R238 fully CCW.
4. Turn Line Switch to ON. Turn the analyzer and audio generator to ON. Increase the audio oscillator output until the analyzer indicates 20.0 vac.
5. Adjust potentiometer R237 clockwise until the positive peak of the waveform, as observed on the oscilloscope, just begins to clip.
6. Adjust potentiometer R238 clockwise until the negative peak just begins to clip.
7. Change output load to 8 ohms. Set analyzer sequentially to 20 Hz, 2 KHz, and 20 KHz. Output voltage should not be less than 21.9 volts.
8. Turn Line Switch to OFF. Arrange setup for Channel B and repeat steps 4 through 7.

G. Relay Operation

1. Turn Line Switch to OFF. Wait approximately 2 minutes.
2. Turn Line Switch to ON. The elapsed time between the instant the power is applied until the relay energizes should be between two and ten seconds.
3. Set Audio Oscillator to 5 Hz with output reduced to minimum.
4. Increase Audio Oscillator output slowly, watching the voltmeter. The relay should de-energize between 10 and 22 volts.

H. Harmonic Distortion Test

1. Set Audio Oscillator frequency to 20 Hz and adjust level for 22V output. Set Distortion Analyzer to SET LEVEL – MANUAL mode. Adjust sensitivity for full scale reading on 0-1 scale.
2. Switch Distortion Analyzer to DISTORTION mode and monitor Channel A output. Total harmonic distortion should be no greater than 0.1%.
3. Repeat test for Channel A with Audio Oscillator frequency set at 20 KHz.
4. Repeat test for Channel A at 20 Hz and 20 KHz with 0.5 MFD across load. Total harmonic distortion should not exceed 0.15%. Verify absence of parasitic oscillation.
5. Perform steps 2, 3, and 4 for Channel B.

J. Short Circuit Test

CAUTION: Do not perform this test if amplifier shows any sign of parasitic oscillation.

1. With amplifier working into an 8 ohm load, set Audio Oscillator level to 22 volts at 200 Hz.
2. Short out each channel with Ammeter. Reading should not exceed 4.5 amperes.

K. Frequency Response Test

1. Using 8 ohm load and Audio Oscillator level at 22 volts, sweep frequency from 20 Hz through 20 KHz.
2. Output voltage should stay between 20.67 vac and 23.61 vac.

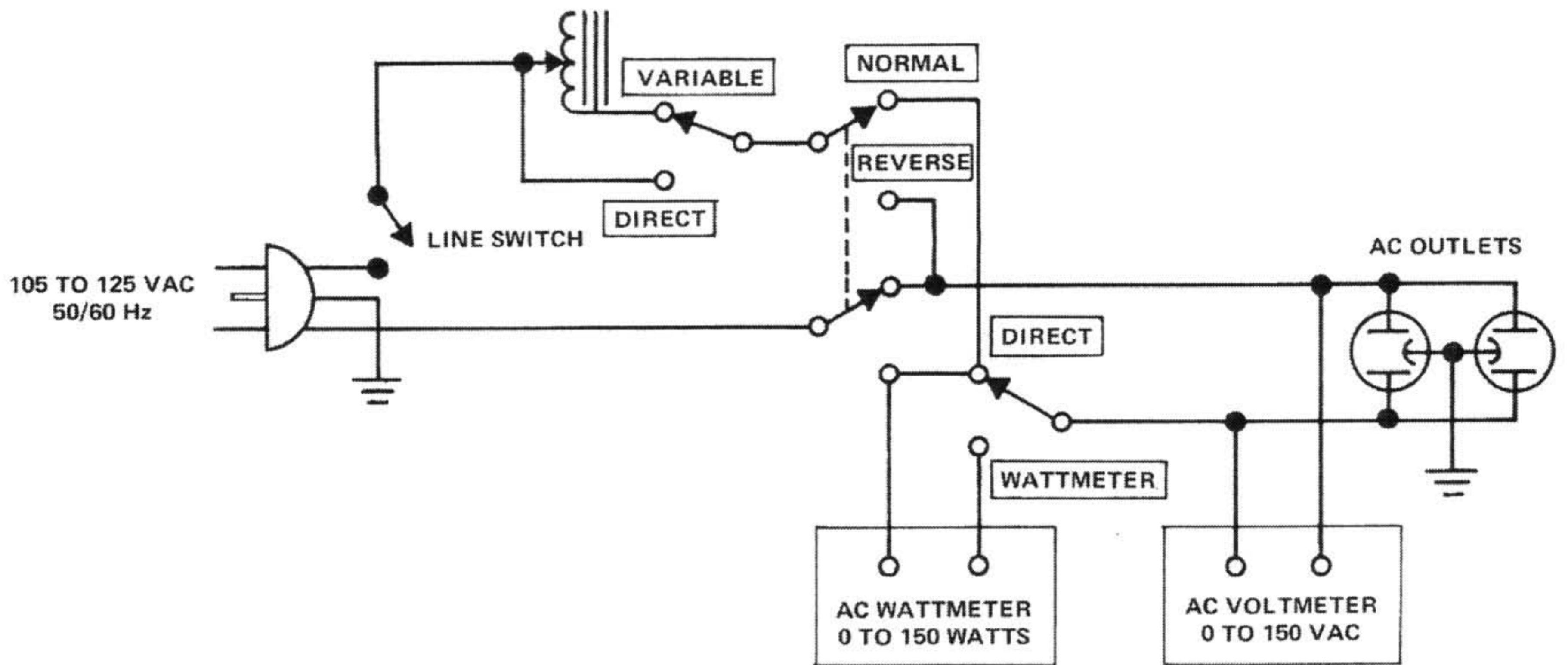

Figure 3. AC Power Control Box Simplified Schematic.

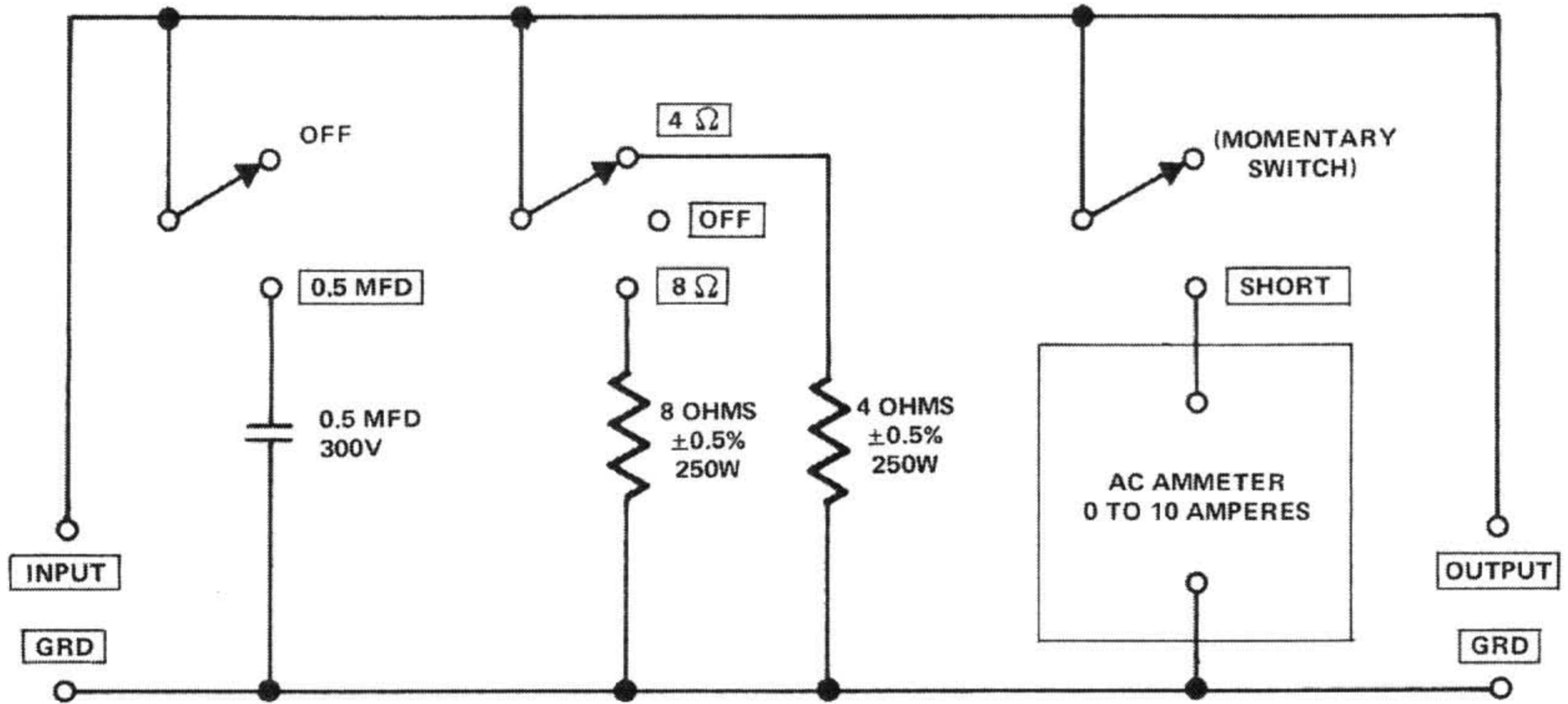

Figure 4. Amplifier Output Load Box Simplified Schematic.

TROUBLE ANALYSIS

The following section is designed to assist in locating troubles. The information given is to help in situations where problems may be difficult to isolate. Any field problems that arise will be covered through service bulletins (supplementary to this manual) that will be issued to all service stations. It is assumed that normal trouble-shooting techniques (i.e., point-to-point signal tracing, oscilloscope analysis, etc.) will be used to isolate problems.

NOTE: Performance verification is necessary following any repair.

SYMPTOM

PROCEDURE

1. Excessive line consumption (100 watts or more)

- a. Check for shorted rectifier CR301, also check C1, C2.
- b. Check for shorted transistors Q1, Q2, Q206 through Q210. Check for open control R224 and bias diode CR203. Check T1 for short.

CAUTION: Because the driver and output stages are direct coupled, components may fail as a direct result of an initial component failure. If a shorted transistor or Zener diode is found, or control, or bias diode, be sure to check the remaining driver and output components for short or open circuits before re-energizing the amplifier. After replacement of any of these components, increase the Variac voltage slowly while monitoring the wattmeter as described in paragraph C of Performance Verification.

2. No line consumption or zero bias.
3. High DC voltage at loudspeaker terminals before time delay circuit is deactivated.
4. High DC voltage at loudspeaker at all times.
5. No DC Balance.
6. High hum and noise level.
7. Parasitic Oscillation.

- a. Check line cord, fuse, transistors Q1, Q2, Q206 through Q212, bias diode CR203.
- b. Check for open rectifier CR301 or open T1.
- a. Check transistors Q301 through Q303 for leakage, shorted, or open.
- a. Check R301 through R305 for open and Q301 for leakage, or open.
- a. Check Q201, Q202, R203, and Zener diodes CR201 and CR202.
- b. Check R202, R204.
- a. Check filter capacitors C1, C2, C201 and C203.
- a. Check for defective C204, C206, C207, and C215.

8. Improper clipping.
 - a. Check for proper adjustment of R237, R238.
 - b. Check Zener diodes CR206 and CR207.
 - c. Check transistors Q1 and Q2.

9. Relay Latching
 - a. Check Q301 through Q303.
 - b. Check output for proper clipping (positive and negative levels must not vary more than 1 volt at 2 KHz).
 - c. Check for high level DC offset at junction of R302 and R305.

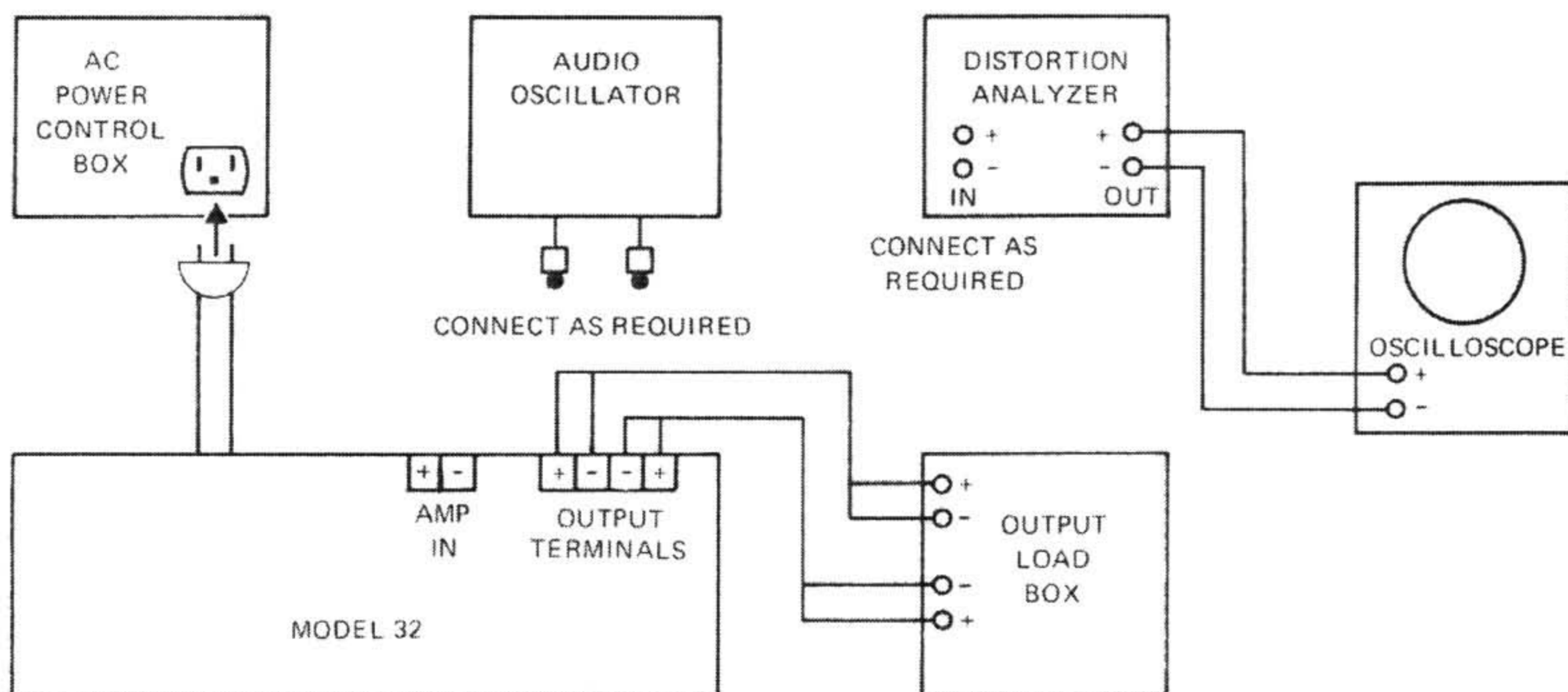

Figure 5. Test Equipment Set-Up.

PARTS LIST

| Reference Designation | Description and/or Remarks | Marantz Part Number |
|-----------------------|----------------------------------|---------------------|
| A1 | Heatsink Assembly | 215-1002-3 |
| A2 | Heatsink Assembly | 215-1002-3 |
| A3 | Power Amp Brd Com Assy | 200-1006-3 |
| A4 | Power Amp Brd Com Assy | 200-1006-3 |
| A5 | Rect/Relay Brd Com Assy | 200-1008-3 |
| C1 | Cap. Elect. 6800 mfd, 50V | 381-1007 |
| C2 | Cap. Elect. 6800 mfd, 50V | 381-1007 |
| C201 | Cap. Elect. 10 mfd, 16V | 381-1015 |
| C202 | Cap. 1.0 mfd, $\pm 10\%$, 250V | 386-1003 |
| C203 | Cap. Elect., 10 mfd, 16V | 381-1015 |
| C204 | Cap. 1300 pfd, 10%, 300V | 385-1033 |
| C205 | Cap. Elect. 50 mfd, 6.4V | 381-1012 |
| C206 | Cap. 5 pfd, $\pm 10\%$, 300V | 385-1009 |
| C207 | Cap. 0.1 mfd, $\pm 10\%$, 250V | 386-1000 |
| C208 | Cap. 0.1 mfd, $\pm 10\%$, 250V | 386-1000 |
| C209 | Cap. 0.1 mfd, $\pm 10\%$, 250V | 386-1000 |
| C210 | Cap. 120 pfd, $\pm 10\%$, 300V | 385-1017 |
| C211 | Cap. 0.22 mfd, $\pm 10\%$, 250V | 386-1001 |
| C212 | Not Used | |
| C213 | Cap. 1000 pfd, $\pm 10\%$, 500V | 385-1007 |
| C214 | Cap. 1000 pfd, $\pm 10\%$, 500V | 385-1007 |
| C215 | Cap. 150 pfd, $\pm 10\%$, 500V | 385-1002 |
| C216 | Cap. 2700 pfd, $\pm 10\%$, 300V | 385-1015 |
| C217 | Cap. 2700 pfd, $\pm 10\%$, 300V | 385-1015 |
| C218 | Not Used | |
| C219 | Not Used | |
| C220 | Cap. 39 pfd, $\pm 10\%$, 500V | 385-1035 |
| C301 | Cap. Elect., 33 mfd, 10V | 381-1021 |
| C302 | Cap. Elect., 125 mfd, 16V | 381-1005 |
| C303 | Cap. Elect., 10 mfd, 64V | 381-1010 |
| CR201 | Diode, Zener | 459-1000 |
| CR202 | Diode, Zener | 459-1000 |
| CR203 | Diode, Rectifier | 460-1010 |
| CR204 | Not Used | |
| CR205 | Not Used | |
| CR206 | Diode, Zener, 10V | 459-1003 |
| CR207 | Diode, Zener, 10V | 459-1003 |

| Reference Designation | Description and/or Remarks | Marantz Part Number |
|-----------------------|----------------------------|---------------------|
| CR301 | Bridge Assy, Rectifier | 468-1000 |
| CR302 | Diode, Rectifier | 460-1006 |
| CR303 | Diode, Rectifier | 460-1006 |
| DS1 | Lamp, Minature Bayonet | 153-1000 |
| DS2 | Lamp, Minature Bayonet | 153-1000 |
| F1 | Fuse, 4A, 250V | 451-1003 |
| K301 | Relay, DPDT, 24V DC | 410-1000 |
| L1 | Toroid | 147-1000 |
| Q1 | Transistor, PNP | 461-1011 |
| Q2 | Transistor, NPN | 462-1015 |
| Q201* | Transistor, NPN | 462-1020-4 |
| Q202* | Transistor, NPN | 462-1020-4 |
| Q203 | Transistor, PNP (Beta>111) | 461-1007 |
| Q204 | Transistor, PNP | 461-1006-1 |
| Q205 | Transistor, NPN | 462-1009-1 |
| Q206 | Transistor, PNP | 461-1007 |
| Q207 | Transistor, NPN | 462-1009-4 |
| Q208 | Transistor, NPN | 462-1007 |
| Q209* | Transistor, NPN | 462-1021 |
| Q210* | Transistor, PNP | 461-1015 |
| Q211 | Transistor, NPN | 462-1016 |
| Q212 | Transistor, PNP | 461-1012 |
| Q301 | Transistor, NPN | 462-1000 |
| Q302 | Transistor, NPN | 462-1007 |
| Q303 | Transistor, NPN | 462-1000 |
| R201 | Res C/F, 470K, 1/2W, 5% | 433-6472 |
| R202 | Res Prec 10K, 1/2W, 2% | 432-5101 |
| R203 | Res Var, 2K, 2W, 10% | 420-1000 |

| Reference Designation | Description and/or Remarks | Marantz Part Number |
|-----------------------|-----------------------------|---------------------|
| R204* | Res C/F, 7.5K, 1/2W, 5% | 433-4752 |
| R205 | Res C/F, 100K, 1/2W, 5% | 433-6102 |
| R206 | Res C/F, 1K, 1/2W, 5% | 433-4102 |
| R207 | Res C/F, 240K, 1/2W, 5% | 433-6242 |
| R208 | Res C/F, 22K, 1/2W, 5% | 433-5222 |
| R209 | Res C/F, 150 ohms, 1/2W, 5% | 433-3152 |
| R210 | Res C/F, 7.5K, 1/2W, 5% | 433-4752 |
| R211 | Res Prec 5.1K, 1/2W, 2% | 432-4511 |
| R212 | Res Prec 100K, 1/2W, 2% | 432-6101 |
| R213 | Res C/C, 27 ohms, 2W, 10% | 424-2273 |
| R214 | Res C/F, 1.8K, 1/2W, 5% | 433-4182 |
| R215 | Res C/F, 56 ohms, 1/2W, 5% | 433-2562 |
| R216 | Res C/F, 300 ohms, 1/2W, 5% | 433-3302 |
| R217 | Res C/F, 5.1K, 1/2W, 5% | 433-4512 |
| R218 | Res C/F, 1.8K, 1/2W, 5% | 433-4182 |
| R219* | Res C/F, 2.2K, 1/2W, 5% | 433-4222 |
| R220 | Res Prec 15K, 1/2W, 2% | 432-5151 |
| R221 | Res Prec 15K, 1/2W, 2% | 432-5151 |
| R222 | Res Prec 680 ohms, 1/2W, 2% | 432-3681 |
| R223 | Res Prec 680 ohms, 1/2W, 2% | 432-3681 |
| R224 | Res Var, 1K, 2W, 10% | 420-1011 |
| R225 | Res C/F, 47K, 1/2W, 5% | 433-5472 |
| R226* | Res C/F, 2.2K, 1/2W, 5% | 433-4222 |
| R227 | Res C/F, 56 ohms, 1/2W, 5% | 433-2562 |
| R228 | Res C/F, 56 ohms, 1/2W, 5% | 433-2562 |
| R229 | Res C/F, 100 ohms, 1/2W, 5% | 433-3102 |
| R230 | Res W/W, 0.2 ohms, 5W, 5% | 439-1000 |
| R231 | Res W/W, 0.2 ohms, 5W, 5% | 439-1000 |
| R232 | Res C/F, 100 ohms, 1/2W, 5% | 433-3102 |
| R233 | Res C/F, 820 ohms, 1/2W, 5% | 433-3822 |
| R234 | Res C/F, 820 ohms, 1/2W, 5% | 433-3822 |
| R235* | Res C/F, 27K, 1/2W, 5% | 433-5272 |
| R236* | Res C/F, 7.5K, 1/2W, 5% | 433-4752 |
| R237 | Res Var, 1K, 1/4W | 420-1013 |
| R238 | Res Var, 1K, 1/4W | 420-1013 |
| R239* | Res C/F, 7.5K, 1/2W, 5% | 433-4752 |
| R240* | Res C/F, 27K, 1/2W, 5% | 433-5272 |
| R241* | Res C/F, 680 ohms, 1/2W, 5% | 433-3682 |

| Reference Designation | Description and/or Remarks | Marantz Part Number |
|-----------------------|--|--|
| R242* | Res C/F, 680 ohms, 1/2W, 5% | 433-3682 |
| R243 | Not Used | |
| R244 | Not Used | |
| R245 | Res C/C, 2.7 ohms, 1W, 10% | 423-1273 |
| R246* | Res C/F, 22 ohms, 1/2W, 5% | 433-2222 |
| R247* | Res C/F, 22 ohms, 1/2W, 5% | 433-2222 |
| R301 | Res C/F, 3.3K, k/2W, 5% | 433-4332 |
| R302 | Res C/F, 10K, 1/2W, 5% | 433-5102 |
| R303 | Res C/F, 27K, 1/2W, 5% | 433-5272 |
| R304 | Res C/F, 75K, 1/2W, 5% | 433-5752 |
| R305 | Res C/F, 7.5K, 1/2W, 5% | 433-4752 |
| R306 | Res C/F, 39K, 1/2W, 5% | 433-5392 |
| R307 | Res C/C, 1.5K, 2W, 10% | 424-4153 |
| R308 | Res C/C, 1.5K, 2W, 10% | 424-4153 |
| R309 | Res C/F, 510K, 1/2W, 5% | 433-6512 |
| R310 | Res W/W, 180 ohms, 2W, 5% | 436-3182 |
| T1 | Transformer, Power | 440-1003 |
| TB1 | Terminal Board, 4 Position | 362-1002 |
| XDS1 | Socket Assy, Pilot Lamp | 481-1003 |
| XDS2 | Socket Assy, Pilot Lamp | 481-1003 |
| XF1 | Fuseholder (W/Mtg Hdwe) | 367-1001 |
| XQ1 | Socket, Transistor | 368-1000 |
| XQ2 | Socket, Transistor | 368-1000 |
| None | Front Panel Assembly Consisting of Panel, Front Mask, Window Window, Marked Lens, Light Deflector Bezel, Front Panel | 206-1001-1 134-1006-1 159-1000 170-1000-1 170-1003-1 172-1000 |
| None | Foot | 567-1000 |

*See ECN Change Record

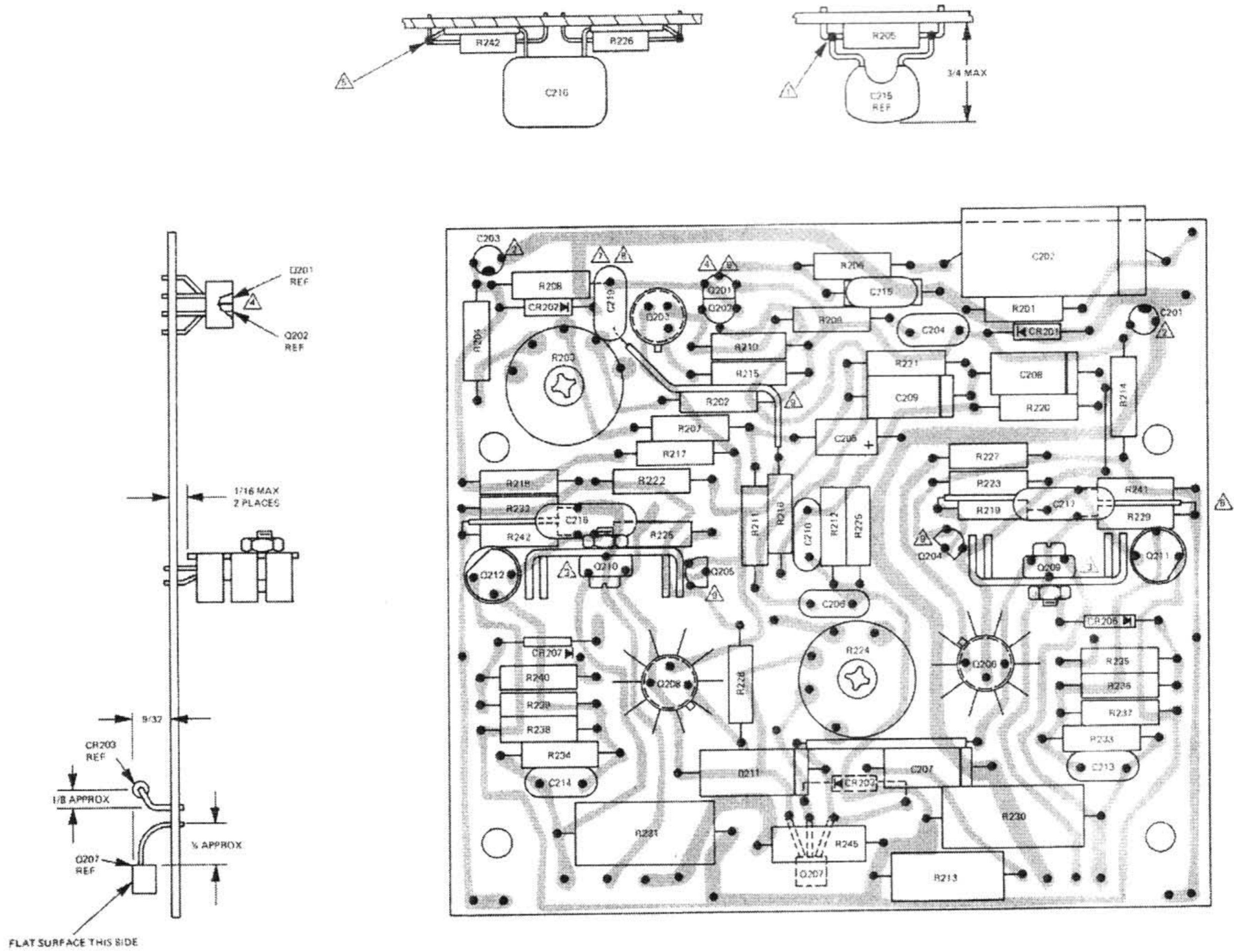

1. INSTALL C215 APPROX. AS SHOWN, WITH LEADS SOLDERED TO R205 LEADS.
2. C201 AND C203 POLARITY IS INDICATED BY COLORED DOT ON ONE SIDE, HOLDING THE CAPACITOR WITH THE COLORED DOT TOWARD THE VIEWER, THE POSITIVE LEAD IS ON THE RIGHT.
3. METAL SIDE OF Q209 AND Q210 TO BE NEXT TO HEAT DISSIPATER.
4. Q201 AND Q202 LOCATED AS SHOWN, WITH CASES TOUCHING. INSTALL HEAT SHRINKABLE TUBING OVER Q201 AND Q202 AND SHRINK.
5. INSTALL C216 APPROX. AS SHOWN, WITH LEADS SOLDERED TO R226 AND R242. C216 LEADS TO BE SLEEVED.
6. INSTALL C217 IN SIMILAR MANNER AS SHOWN FOR C216 WITH LEADS SOLDERED TO R219 AND R229. C217 LEADS TO BE SLEEVED.
7. C219 OPTIONAL ITEM.
8. INSTALL C219 AS SHOWN (BETWEEN R208 AND R216 SLEEVE LEADS).
9. Q201, Q202, Q204, AND Q205 ARE TO BE INSTALLED WITHOUT CUTTING TRANSISTOR LEAD. HEIGHT OF THE TRANSISTOR OFF THE BOARD NOT TO EXCEED 1/2".

Figure 6. Power Amplifier Board Component Assembly Diagram Revision 1.

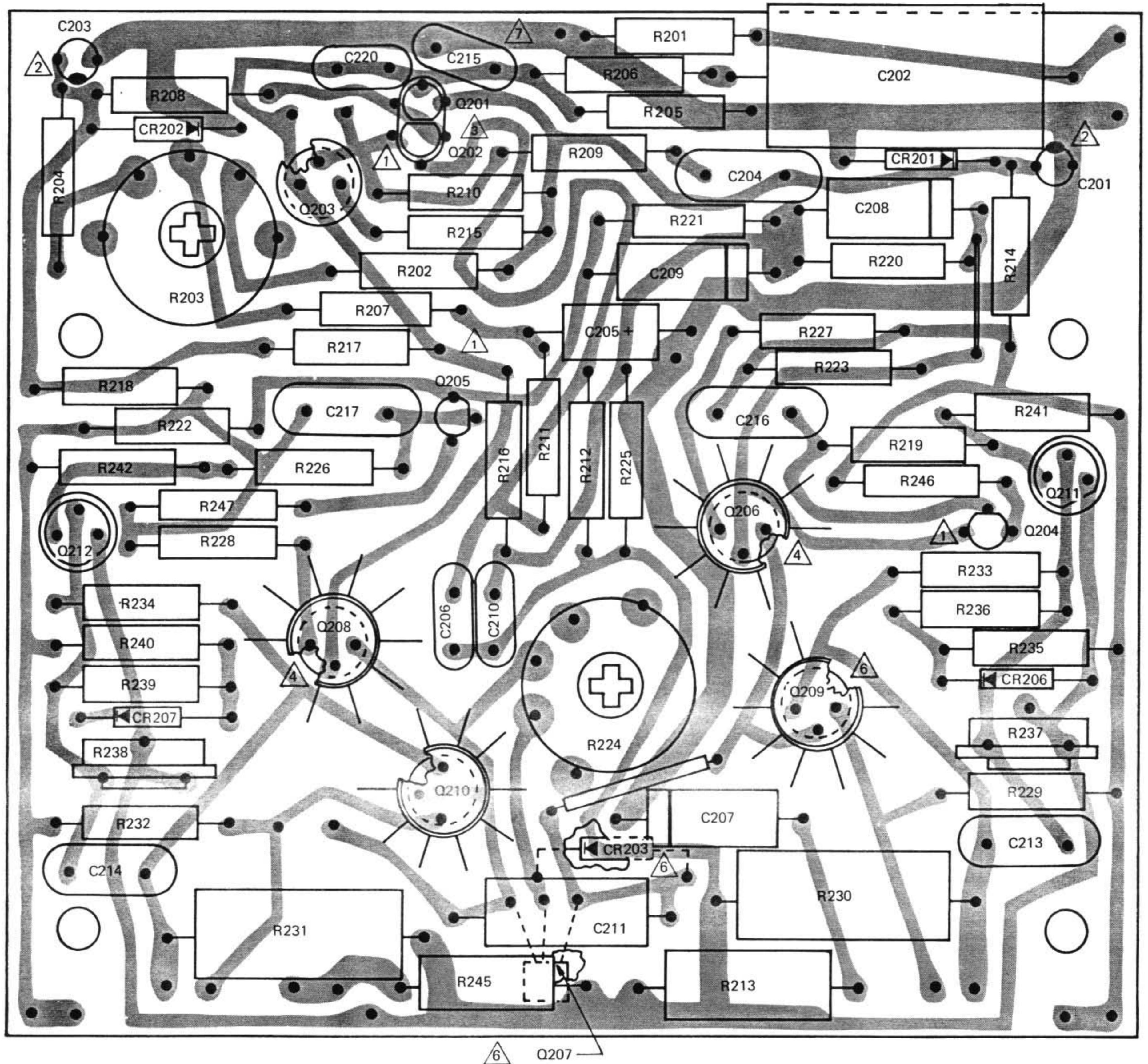

- 1. Q201, Q202, Q204, AND Q205 ARE TO BE INSTALLED WITHOUT CUTTING TRANSISTOR LEADS. HEIGHT OF THE TRANSISTOR OFF THE BOARD NOT TO EXCEED 1/2".
- 2. C201 AND C203 POLARITY IS INDICATED BY COLORED DOT ON ONE SIDE, HOLDING THE CAPACITOR WITH THE LEADS DOWN AND THE COLORED DOT TOWARD THE VIEWER, THE POSITIVE LEAD IS ON THE RIGHT.
- 3. Q201 AND Q202 LOCATED AS SHOWN, WITH CASES TOUCHING. INSTALL HEAT SHRINKABLE TUBING OVER Q201 AND Q202 AND SHRINK.

- 4. Q206 AND Q208 TO BE MATCHED WITHIN 1 (ONE) BETA RANGE. Q209 AND Q210 TO BE MATCHED IN SAME BETA RANGE. BETA RANGES ARE 40-99, 100-149, 150-199, 200-399 AND 400 OR GREATER.
- 5. USE BOARDS FABRICATED FROM A/W 115-1006 REV G ONLY FOR ASSEMBLY CONFIGURATION SHOWN.
- 6. CR203 AND Q207 ARE INSTALLED IN SAME MANNER AS SHOWN IN FIGURE 6.
- 7. C215 OPTIONAL ITEM.

Figure 7. Power Amplifier Board Component Assembly Diagram Revision 2.

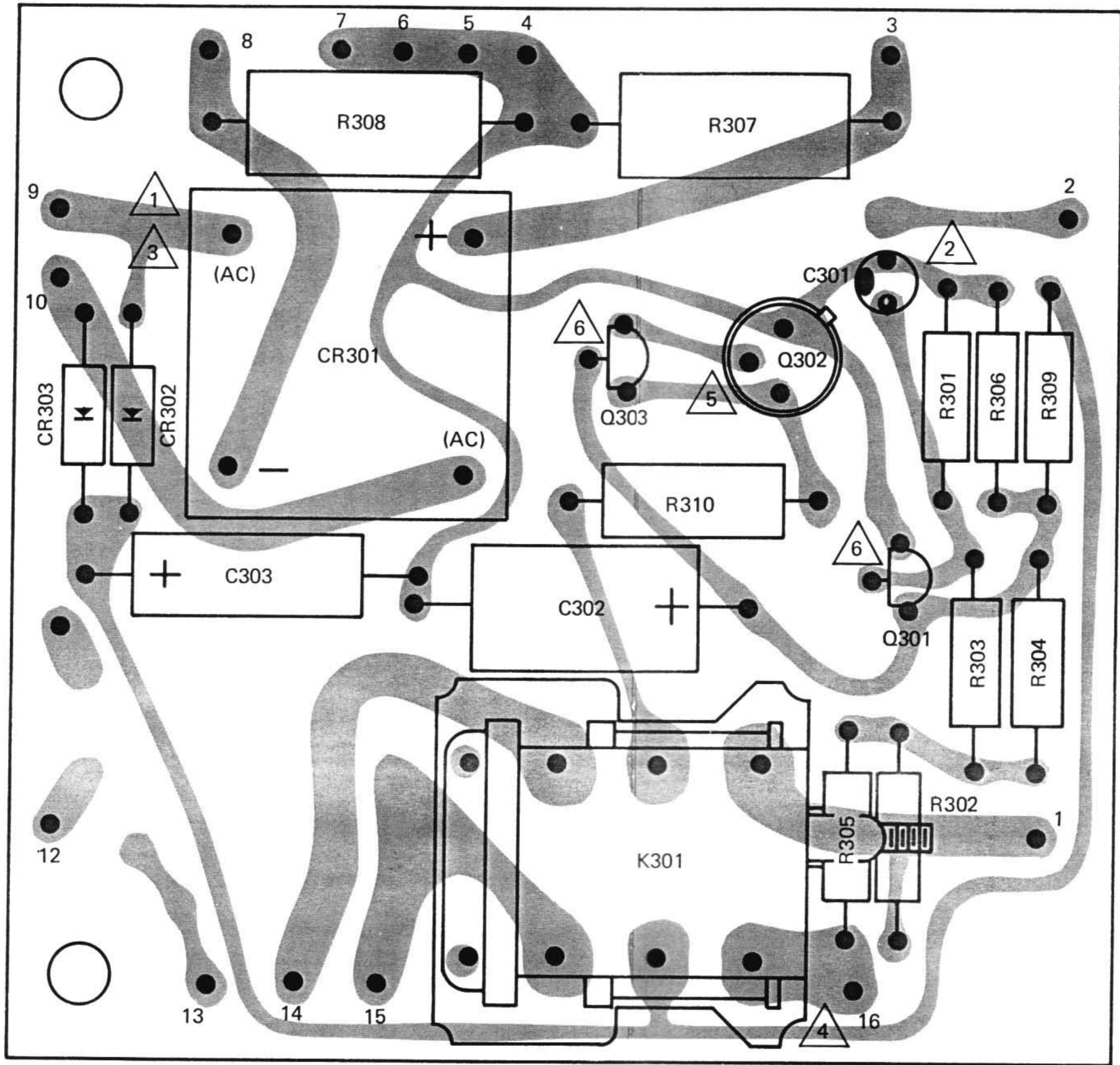

- | | |
|---|--|
| <p>1. RED DOT INDICATES POSITIVE LEAD OF CR301 AND MAY BE LOCATED ON LEAD SIDE OR OPPOSITE LEAD SIDE OF COMPONENT.</p> <p>2. C301 POLARIZATION IS DETERMINED BY HOLDING THE COMPONENT WITH THE BLACK MARKING TOWARD VIEWER – IN THIS POSITION THE POSITIVE LEAD IS ON THE RIGHT.</p> <p>3. CR301 TO BE INSTALLED FLUSH TO 1/8" ABOVE BOARD.</p> | <p>4. RELAY TERMINALS NEED NOT BE TRIMMED.</p> <p>5. Q302 TO HAVE A BETA GREATER THAN 30.</p> <p>6. Q301 AND Q303 ARE TO BE INSTALLED WITHOUT CUTTING TRANSISTOR LEADS. HEIGHT OF THE TRANSISTOR OFF THE BOARD NOT TO EXCEED 1/2".</p> |
|---|--|

Figure 8. Rectifier/Relay Board Component Assembly Diagram.

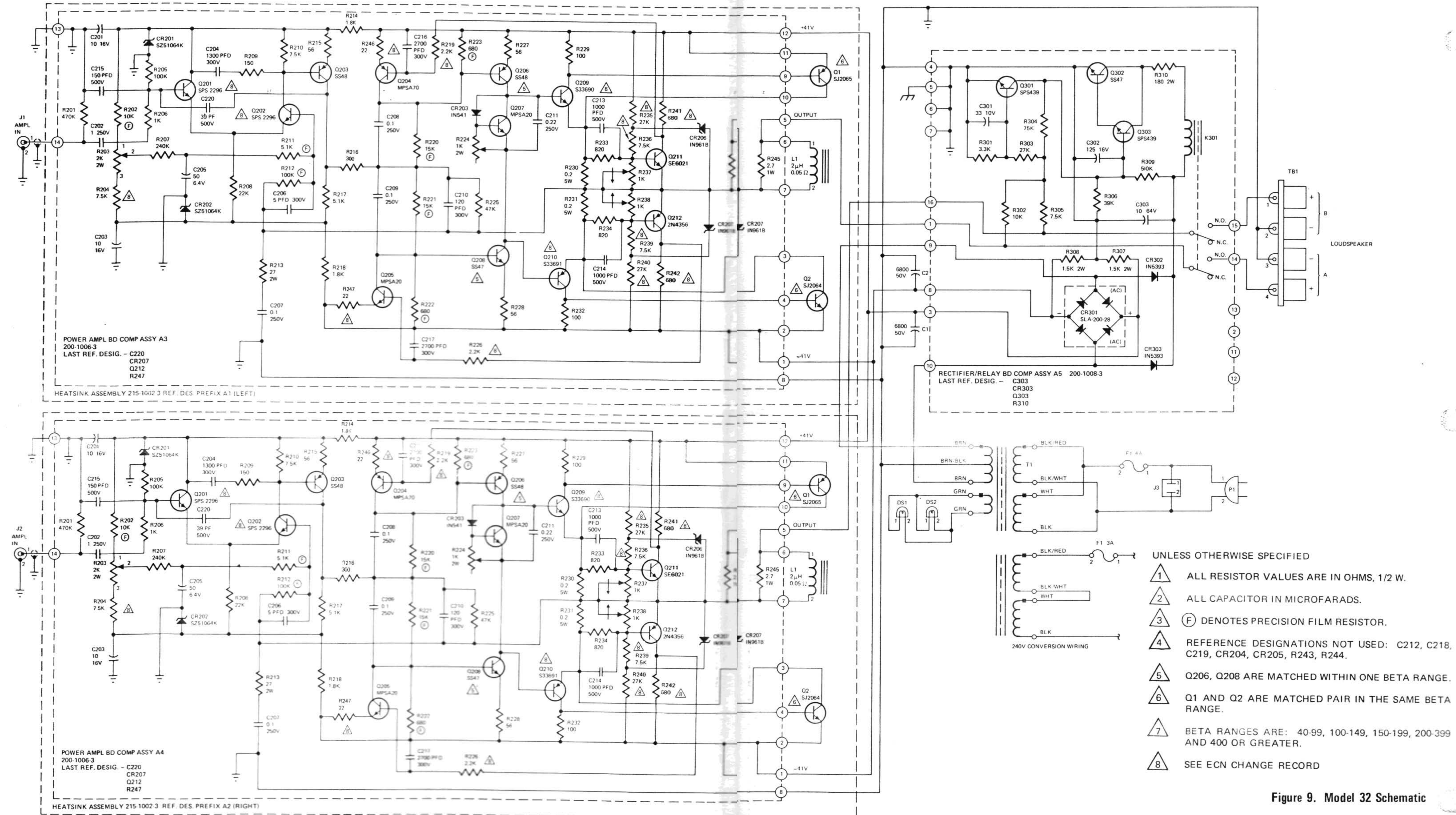

- UNLESS OTHERWISE SPECIFIED
- 1 ALL RESISTOR VALUES ARE IN OHMS, 1/2 W.
 - 2 ALL CAPACITOR IN MICROFARADS.
 - 3 (F) DENOTES PRECISION FILM RESISTOR.
 - 4 REFERENCE DESIGNATIONS NOT USED: C212, C219, CR204, CR205, R243, R244.
 - 5 Q206, Q208 ARE MATCHED WITHIN ONE BETA RANGE.
 - 6 Q1 AND Q2 ARE MATCHED PAIR IN THE SAME BETA RANGE.
 - 7 BETA RANGES ARE: 40-99, 100-149, 150-199, 200-399 AND 400 OR GREATER.
 - 8 SEE ECN CHANGE RECORD

Figure 9. Model 32 Schematic

CHANGE RECORD

Enter changes on the Model 32 here for a permanent record. Insert pages into manual. Retain or discard old pages, as instructed.

| ECN NO. | DATED | DESCRIPTION | INSERTED BY | DATE |
|---------|---------|---|-------------|-----------------|
| 1362 | 5/14/70 | Added R246, R247 10 ohm, ½W, 5% | KFH | 1 December 1970 |
| 1410 | 6/30/70 | Q201, Q202 was MPSA09 is SPS2296 | KFH | 1 December 1970 |
| 1435 | 8/14/70 | Q210 was SJE569 is S33691 Q209 was SJE570 is S33690 R246, R247 was 10 ohm is 22 ohm R236, R239 was 5.6K is 7.5K R219, R226 was 5.6K is 2.2K R235, R240 was 43K is 27K R241, R242 was 5.6K is 1.5K R204 was PREC. 10K, 2% is 7.5K, 5% | KFH | 1 December 1970 |
| 1509 | 8/19/70 | R241, R242 was 1.5K is 680 ohm | KFH | 1 December 1970 |

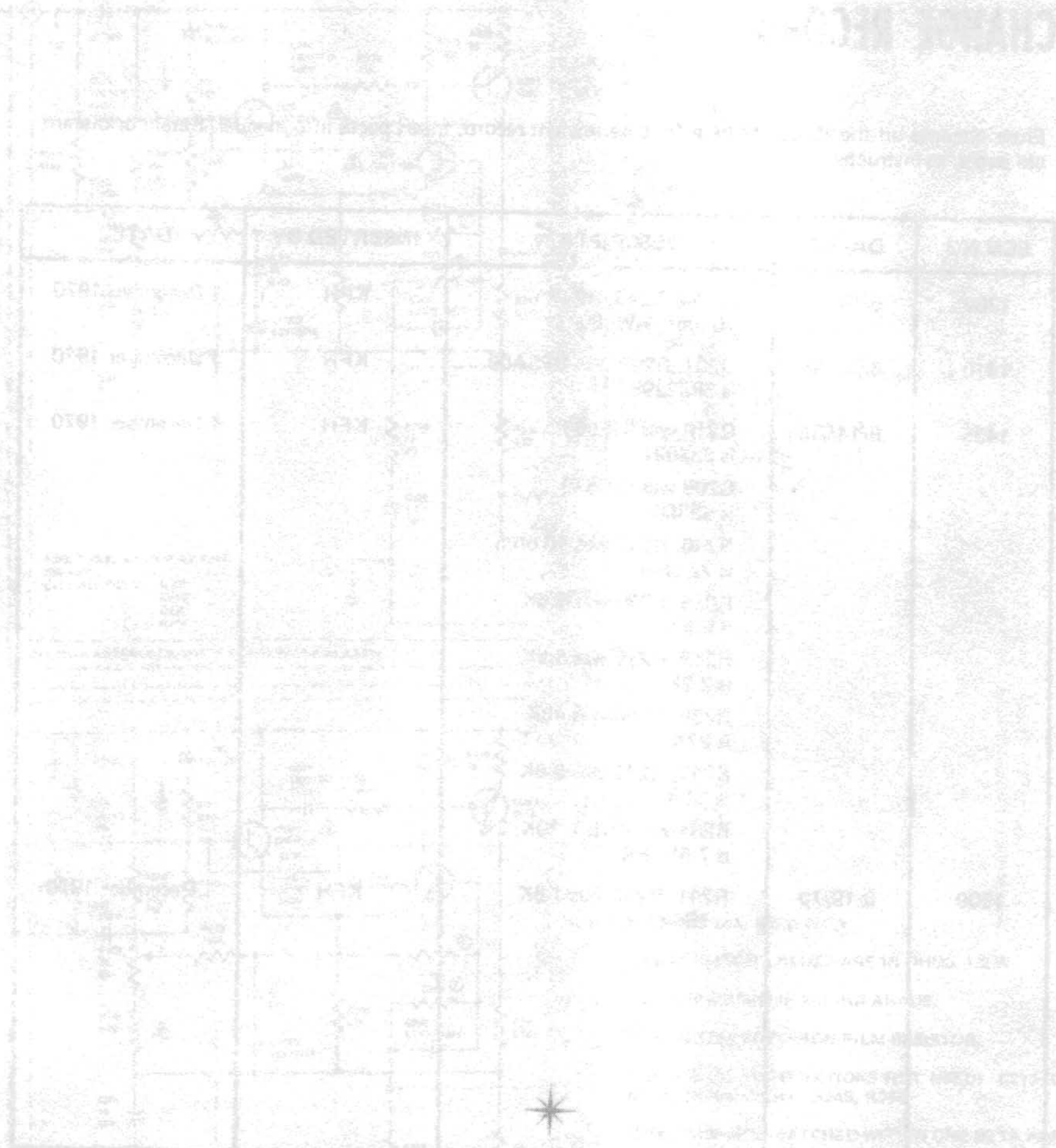

marantz.

MARANTZ CO., INC. • P.O. BOX 99 • SUN VALLEY, CALIFORNIA • 91352
 A WHOLLY-OWNED SUBSIDIARY OF SUPERSCOPE INC., SUN VALLEY, CALIFORNIA 91352