

marantz®

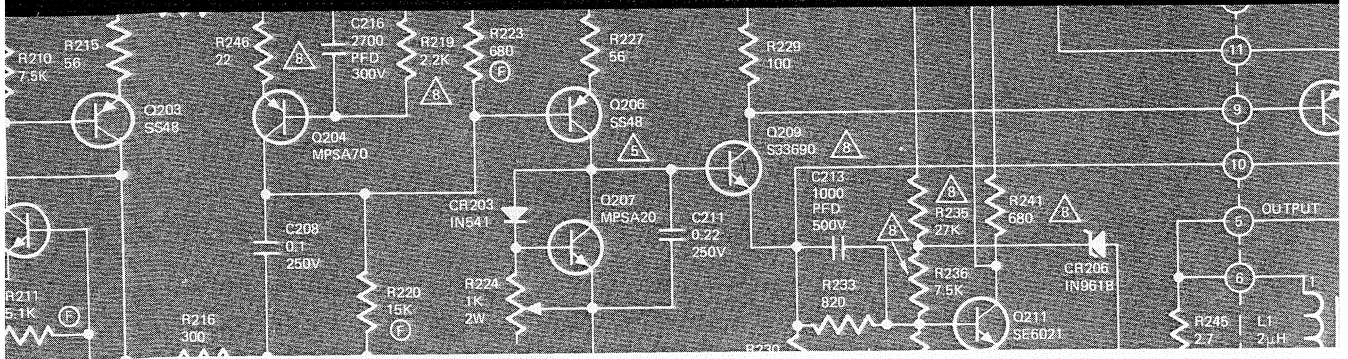

SERVICE MANUAL

MODEL 1120

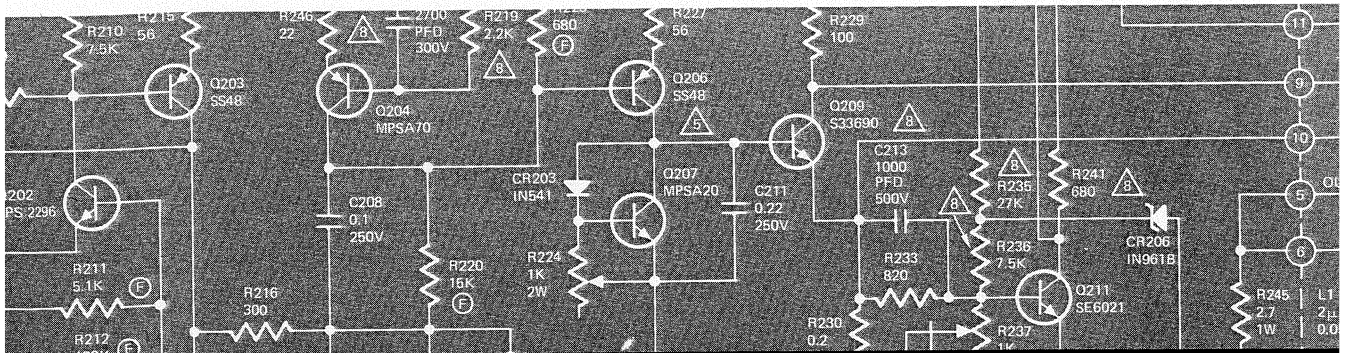

Stereo Console Amplifier

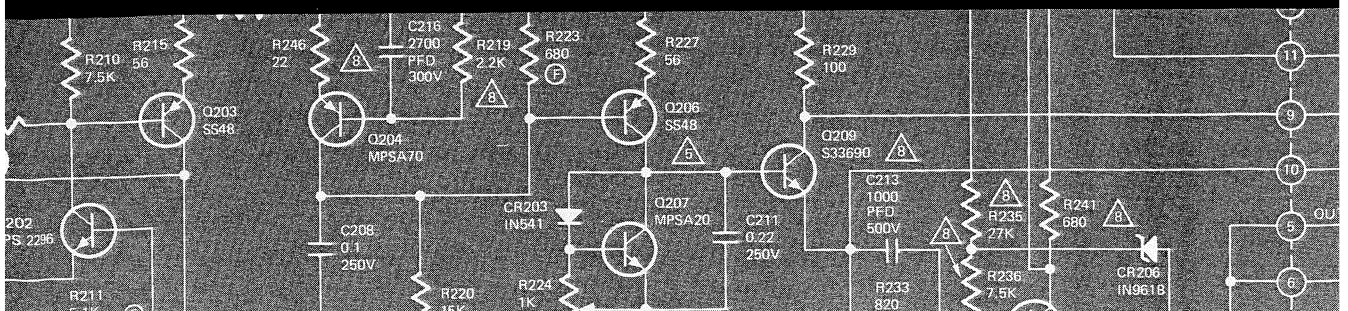

TABLE OF CONTENTS

SECTION	PAGE		
		Service Notes	12
		Disassembly/Re-assembly Instructions	12
Introduction	1	Top Cover	12
Caution	1	Heatsink Assembly	12
Technical Specifications	2	Power Amplifier Board Assembly	12
Recommended Test Equipment	3	Power Transistors	13
Performance Verification	5	Bias Diodes	13
Test Procedure	5	Front Panel	13
Test Equipment	5	Phono/Select Board Assembly	13
Preliminary Procedures	5	X10/Tone Board Assembly	14
Idling Power Test	6	Power Supply Board Assembly	14
Relay Operation Test	6	Interconnect Board Assembly	14
DC Balance Test	6	Pilot Lamp	15
Total Hum and Noise Test	6	Power Transformer	15
Maximum Power Output Test	6	Voltage Conversion Instructions	15
Harmonic Distortion Test	7	220-Volt AC Conversion	15
Short Circuit Test	7	100-Volt AC Conversion	15
Frequency Response Test	7	Parts List ("Loose" Parts)	16
Gain Test	7	Parts List - Jack Panel Board	
Channel Separation Test	7	Assembly	18
Filter and Tone Circuit Test	7	Parts List - Phono/Select Board	
Loudness Circuit Test	8	Assembly	20
Adjustment Procedure	8	Parts List - Interconnection Board	
Test Equipment	8	Assembly	22
Preliminary Procedures	8	Parts List - X10/Tone Board Assembly	24
Unit Disassembly	8	Parts List - Heatsink/Power	
Bias Adjust	8	Amplifier Board Assembly	26
DC Balance Adjust	8	Parts List - Power Supply Board	
		Assembly	27

LIST OF ILLUSTRATIONS

FIGURE		PAGE
1	Model 1120 Front View	1
2	Model 1120 Rear View	1
3	AC Power Control Box Schematic	4
4	Amplifier Output Load Box Schematic	4
5	Test Equipment Set-Up	5
6	RIAA Equalization Curve	7
7	Model 1120 Schematic	9&10
8	Functional Block Diagram	11
9	Model 1120 Interior View	17
10	Jack Board Assembly - A6	18
11	Phono/Selector Switch Board Assembly - A2	19
12	Interconnection Board Assembly - A1	21&22
13	X10/Tone Board Assembly - A3	23&24
14	Power Amplifier Board Assembly - A5	25
15	Heatsink/Power Amplifier Assembly	26
16	Power Supply Board Assembly - A4	27&28

TABLE		PAGE
1	Recommended Test Equipment	3

MODEL 1120

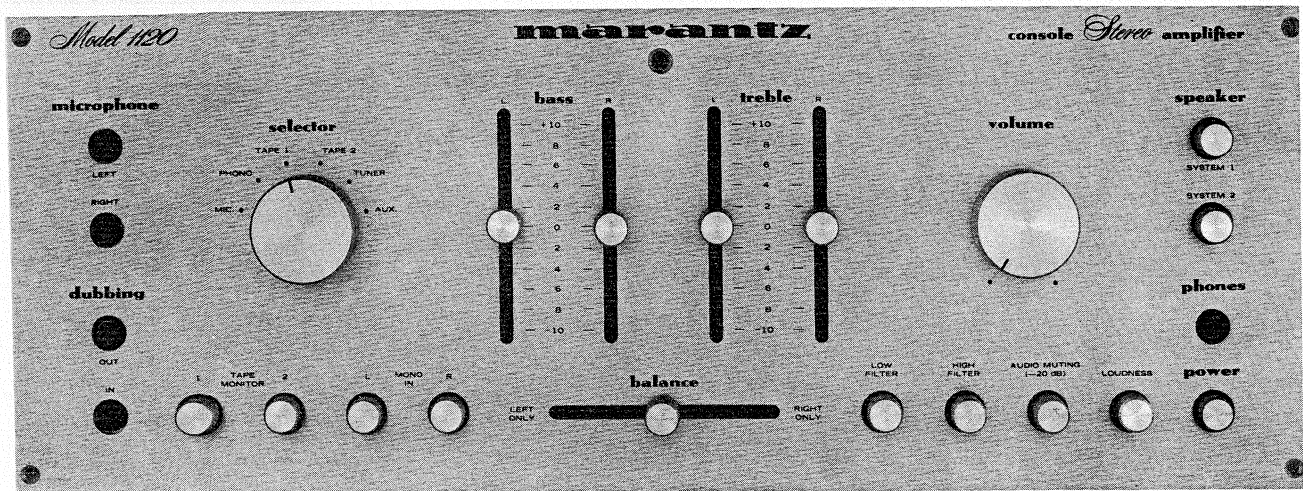

Figure 1. Model 1120 Front View

INTRODUCTION

This service manual was prepared for and is intended for use only by factory authorized warranty repair stations and other equally qualified and equipped facilities. The service information contained herein is applicable to the Model 1120 Stereo Console Amplifier, manufactured by the Marantz Company, a subsidiary of Superscope Incorporated, Sun Valley.

Performance evaluation and service of the Model 1120 should be undertaken only by the experienced technician, one knowledgeable in solid-state amplifier operation and use of the test equipment. All instructions should be read carefully and understood fully before proceeding with any service. To better understand the functions of this amplifier, consult the Model 1120 Handbook of Instructions (P/N 199-1090-000) which provides a functional and brief technical description of the unit.

CAUTION

1. The full line voltage exists at the terminal strip mounted at the top of the power transformer half-shell. Care should be exercised to insure that these terminals are not accidentally contacted causing harm to the technician and/or the equipment.
2. Do not discharge any capacitors in the Model 1120 with a dead short (i.e. a screw driver blade). The filter capacitors are capable of storing a sizeable charge and the current delivered through a short-circuit may be sufficient to vaporize the screw driver causing harm to the technician or the equipment. Always use a 10-ohm 1 watt resistor for this purpose.
3. All adjustments should be made using screw drivers with insulated blades and handles. Otherwise, shorting of adjacent components may occur.
4. Never directly connect the loudspeaker terminals of one channel in parallel with those of any other, as severe damage to the output devices will result.

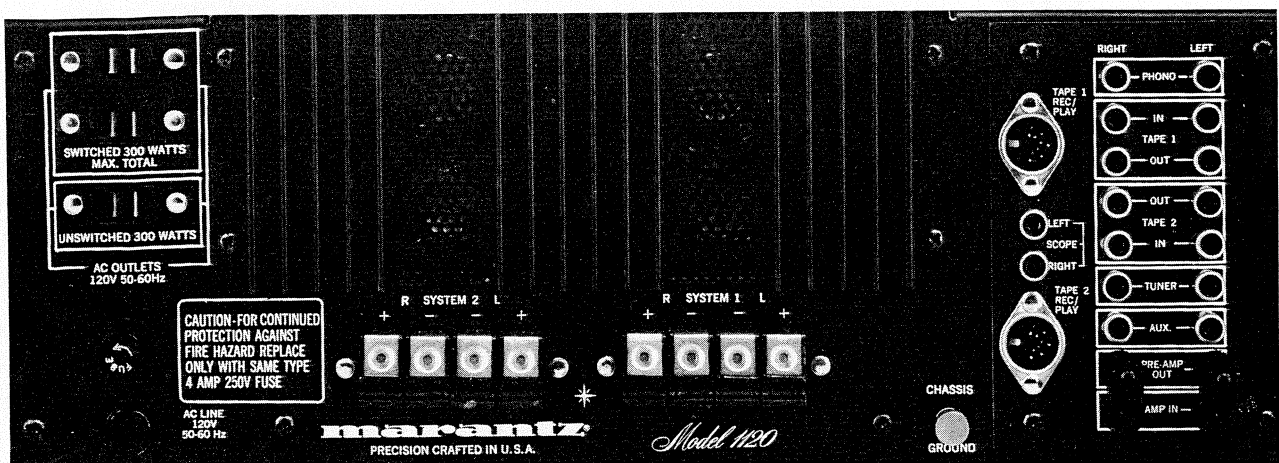

Figure 2. Model 1120 Rear View

TECHNICAL SPECIFICATIONS

Preamplifier Only:

Gain – Phono Amplifier	40 dB
– X10/Tone Amplifier	20 dB
Input Impedance – Low Level (Phono)	47K ohms
– Low Level (Microphone)	47K ohms
– High Level (All)	25K ohms
Input Sensitivity – Low Level	1.1 mV to equal 1.1V output at Pre-Amp Out
– High Level	110 mV to equal 1.1V output at Pre-Amp Out
Volume Tracking	Within ± 2 dB

Preamplifier/Amplifier Combined:

Gain – Phono Input to Speaker Terminals	86 dB
Frequency Response (20 Hz to 20 KHz at 1 Watt output, Tone Controls electrically flat)	+0.5 dB -0.5 dB
Damping Factor	Greater than 30 into 8-ohm load
Intermodulation Distortion	Less than 0.2% at rated power output with both channels driven (S.M.P.T.E.)
Total Harmonic Distortion	Less than 0.2% at rated power output 20 Hz - 20 KHz with both channels driven
Equivalent Noise – From magnetic Phono Input to Speaker Terminals	Better than 140 dB below 60 watts (8-ohm load)

Power Output – 20 Hz - 20 KHz (each channel with both channels driven)	Load	RMS Power	IHF Power
	4 ohms	70 watts	105 watts
	8 ohms	60 watts	90 watts
	16 ohms	30 watts	45 watts

Operating (Primary) Power Requirements*	Nominal Voltage	Range	Max Power	Frequency	Fuse
	100 vac	90-110 vac	200 watts	50-60 Hz	4.0A
	120 vac	108-132 vac	200 watts	50-60 Hz	4.0A
	220 vac	200-240 vac	200 watts	50-60 Hz	3.0A

Dimensions – Panel	15-3/8 inches Wide x 5-3/4 inches High
– Unit Depth	13-1/4 inches

Weight – Unit alone	27 lbs
– Packed for shipment	33 lbs

*Special primary windings permit conversion to 100 volt or 220 volt operation.

ODEL 1120

RECOMMENDED TEST EQUIPMENT

The test equipment listed below is recommended for servicing the Model 1120 Stereo Console Amplifier. The performance Verification and Alignment Procedure sections of this manual are based on the use of these items or their equivalent.

TABLE 1		
Item	Manufacturer and Model Number	Use
AC Wattmeter	Simpson Model 390	Monitors primary power consumption of amplifier
Line Voltmeter (0-150 vac)	Commercial Grade	Monitors potential of primary power to amplifier
Variable Autotransformer (0-140 vac, 10 amps)	Powerstat Model 116B	Controls level of primary power to amplifier
Above items to be assembled per Figure 3 as AC Power Control Box		
AC Ammeter (0-10 amps)	Commercial Grade	Monitors amplifier output under short circuit conditions
Output Load Resistor ($8\Omega \pm 0.5\%$, 250W) 2 Required	Commercial Grade (Non-Inductive)	Provides 8-ohm load for amplifier output termination
Output Load Resistor ($4\Omega \pm 0.5\%$, 250W) 2 Required	Commercial Grade (Non-Inductive)	Provides 4-ohm load for amplifier output termination
Output Load Capacitor (0.5 mfd, 300V) 2 Required	Mylar	Provides capacitive load for instability checks
Above items to be assembled per Figure 4 as Amplifier Output Load Box		
Distortion Analyzer	Hewlett Packard Model 331A or 333A	Measures distortion and voltage of amplifier output
Audio Oscillator	Weston Model CVO-100P (Note: Less than 0.02% residual distortion is required)	Sinewave signal source
Oscilloscope	Tektronix Model 503 or Data Model 555	Waveform analysis
VTVM	RCA Senior Volt-Ohmyst Model WV-98C	Voltage and resistance measurements
Shorting Plug	Use phono plug with 600 ohms across center pin and shell	Shorts amplifier input to eliminate noise pickup
Above items are assembled per Figure 5 or as directed in Test or Alignment Procedures		
Power Supply Bleeder Resistor (10Ω , 1W)	Commercial Grade	Discharges power supply filter capacitors prior to disassembly or resistance measurements

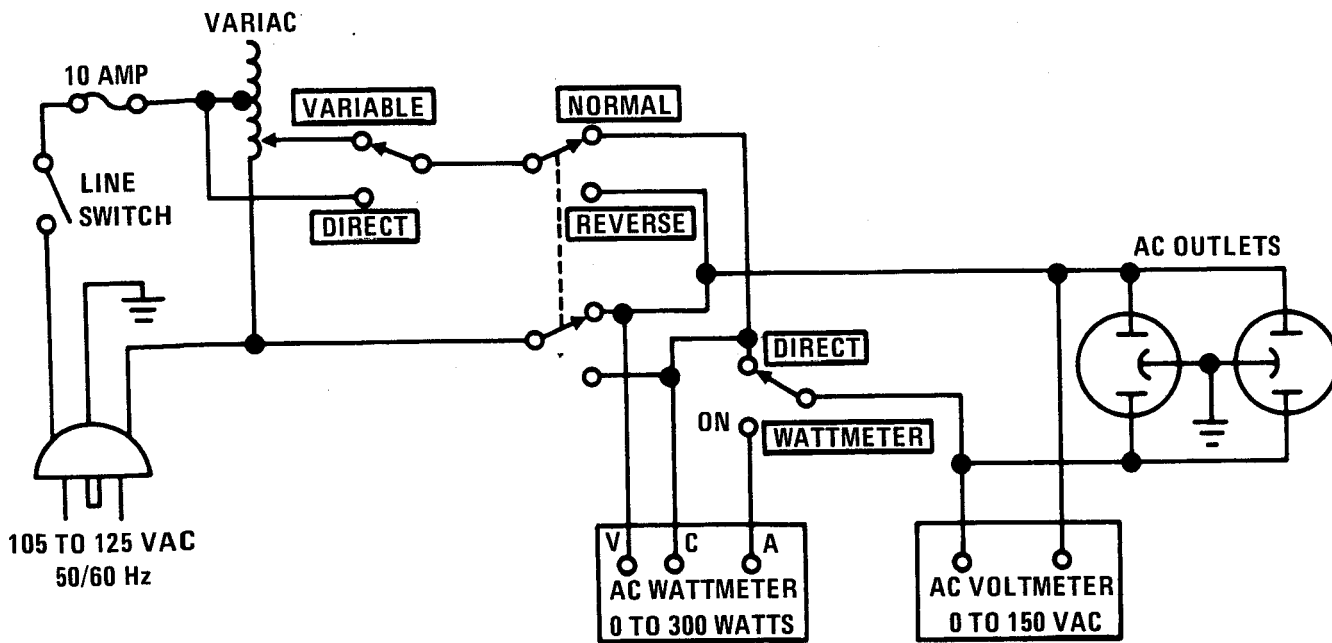

Figure 3. AC Power Control Box Schematic

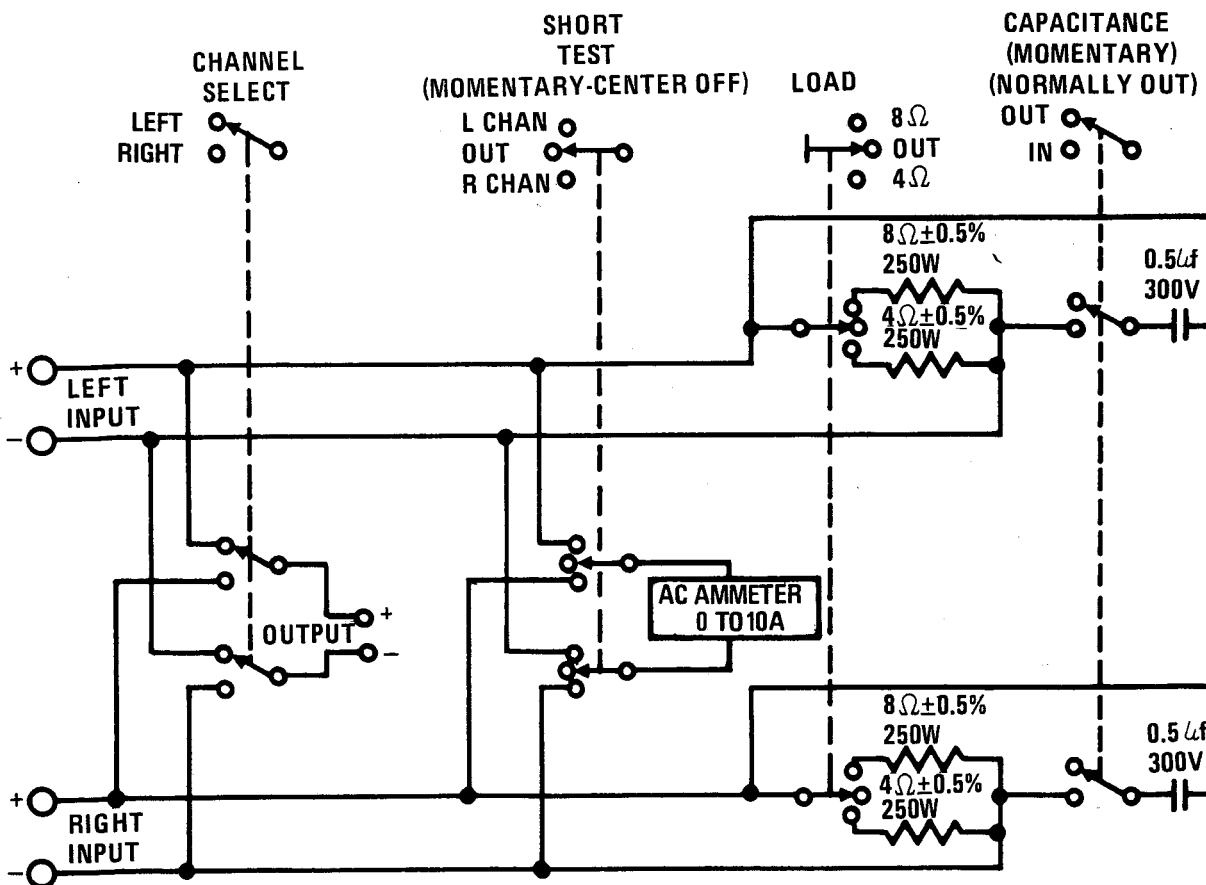

Figure 4. Amplifier Output Load Box Schematic

MODEL 1120

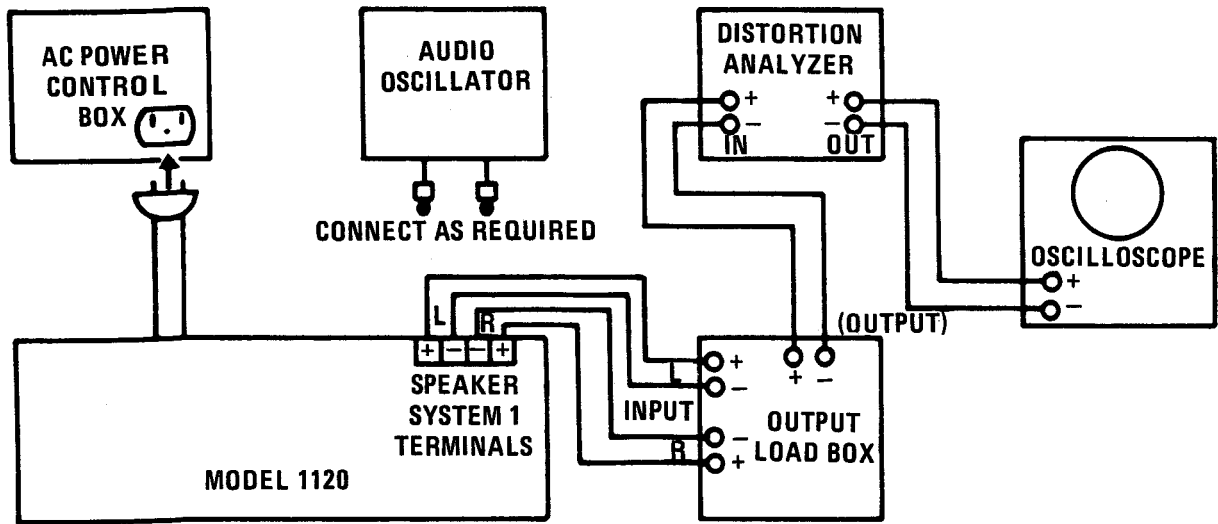

Figure 5. Test Equipment Set-up

PERFORMANCE VERIFICATION

TEST PROCEDURE

All tests outlined below should be performed after any repair or adjustment. The tests described in paragraph C through O may also be used as a method of isolating the defect prior to service. Should the results of the tests be other than as specified, refer to the Adjustment Procedure section of this manual. Unless the test is performed with both channels driven, all tests are to be performed on both audio channels, with the specified results applying equally to each channel.

A. TEST EQUIPMENT

Refer to Table 1 for the list of recommended test equipment.

B. PRELIMINARY PROCEDURES

- All tests are performed with the unit under test and the test equipment connected as shown in Figure 5. Except for the IDLING POWER test, all tests are performed with 120 VAC line voltage applied to the unit. Unless otherwise specified in the procedure, the test equipment controls will be set in the following position during each test.

AC Power Control Box

Line Switch ON
 Wattmeter Switch. DIRECT
 Variac 120 VAC LINE

Amplifier Output Load Box

Channel
 Select LEFT CHANNEL
 Short Switch CENTER (OFF)
 (Momentary)
 Load Switch. 8 OHMS
 Capacitance Switch OUT
 (Momentary)

Unless otherwise specified in the procedure, the Model 1120 under test will have its controls set in the following positions during each test.

Tape Monitor 1. OUT
 Tape Monitor 2. OUT
 Mono In L OUT
 Mono In R OUT
 L Bass CENTER DETENT
 R Bass CENTER DETENT
 Balance CENTER DETENT
 L Treble CENTER DETENT
 R Treble CENTER DETENT
 Low Filter OUT
 High Filter OUT
 Audio Muting (-20dB) OUT
 Volume MAX (FULLY CW)
 Loudness OUT
 Power IN (ON)
 Speaker System 2 OUT
 Speaker System 1 IN

2. Connections between the output terminals of the Model 1120 and the Output Load Box must have negligible resistance with respect to the resistance of the load itself. Appreciable resistance in the wiring adds to the total load, resulting in inaccurate measurement of output power.

C. IDLING POWER

1. With the Line Switch OFF, the Variac set to 0 (fully CCW) and the Wattmeter Switch to WATTMETER, plug the unit line cord into the AC Power Control Box.
2. On the Amplifier Output Load Box, set the Load Switch to OUT.
3. Turn the Line Switch ON and slowly advance the Variac while observing the Voltmeter and Wattmeter on the Power Control Box. When the line voltage reaches 120 vac, the Wattmeter should indicate between 15 and 35 watts.
4. If the Wattmeter reading is greater than 35 watts for any static Variac position, do not further increase the AC voltage. Turn off the unit and correct the fault.

D. RELAY OPERATION

1. Set Line Switch to OFF. Wait approximately 30 seconds.
2. Switch line ON. Time the delay between power turn-on and the moment that the relay energizes (signaled by an audible click within the amplifier). The elapsed time should be between 2 and 10 seconds.
3. Connect the Audio Oscillator to the AUX input jacks of both channels. Set the SELECTOR switch in the AUX position. With the oscillator level set to minimum adjust the frequency to 5Hz.
4. Slowly increase the oscillator level until the relay opens, carefully observing the highest output voltage reached prior to relay cut-off. The voltage should be between 12 and 22 volts.

E. DC BALANCE

1. With the Load Switch on the Amplifier Output Load Box set to OUT, connect a

VTVM (set in the DC MODE) to the output terminals of the Load Box.

2. Allow the unit to reach operating temperature (approximately 2 minute warm-up).
3. Check each channel for a DC voltage of $0V \pm 50mV$.

CAUTION: THE OUTPUT VOLTAGE MAY BE AS HIGH AS $\pm 44V$ IN A UNIT WITH MULTIPLE OPERATING DEFECTS.

F. TOTAL HUM AND NOISE TEST

1. With the Shorting Plugs in each PHONO input jack, set the SELECTOR switch to PHONO and the VOLUME control to minimum (fully CCW). The output voltage should be 2mV or less for each channel.
2. Advance the unit VOLUME control to maximum (fully CW). The output voltage should be 35mV or less for each channel.

G. MAXIMUM POWER OUTPUT

1. Connect the Audio Oscillator to the AUX input jack of each channel. Set the oscillator level to minimum, oscillator frequency to 2KHz, and unit SELECTOR switch to the AUX position. Switch in the 4 ohm load.
2. Advance the oscillator level until the positive and negative waveforms just begin to clip. The output voltage should be 15.5V or more.
3. Change load to 8 ohms.
4. Set the Audio Oscillator level for 21.9 volts output. Verify that neither channel is clipping.
5. Change the oscillator frequency to 20Hz and re-adjust the level (if necessary) for 21.9V output. Verify lack of clipping on both channels.
6. Reset the oscillator frequency to 20KHz and reset level (if required) for 21.9V output. Neither channel should be clipping.

MODEL 1120

H. HARMONIC DISTORTION TEST

1. With the Audio Oscillator connected to the AUX input jacks of both channels, set the frequency to 20Hz and the level for 21.9V output into an 8 ohm load.
2. Set the unit SELECTOR switch to the AUX position. Verify that the distortion is 0.2% or less.
3. Change the oscillator frequency to 20KHz and re-adjust the level (if necessary) for an output of 21.9V. The measured distortion should be 0.2% or less.
4. Switch the Output Load Capacitance to IN. Verify the lack of parasitic oscillation. The distortion should not exceed 0.3%.
5. Remove capacitance from load. Reduce the oscillator level to a 2.83V output. The distortion should not be greater than 0.2%.

J. SHORT CIRCUIT TEST

CAUTION: DO NOT PERFORM THIS TEST IF THE AMPLIFIER SHOWS ANY SIGNS OF PARASITIC OSCILLATION (SEE HARMONIC DISTORTION TEST).

1. With the Audio Oscillator connected to the Aux input jacks of both channels, set the Oscillator frequency to 200Hz. Adjust the level for 21.9V output into an 8 ohm load.
2. Short the output of each channel with an ammeter ("SHORT TEST" switch on Load Box).

NOTE: The output terminals should not remain shorted for more than 3 seconds.

3. The ammeter reading should be 8 Amps ± 1 Amp.

K. FREQUENCY RESPONSE TEST

1. With the Audio Oscillator frequency set to 20Hz, connect it to the AUX input jacks of each channel. Set the level for an output of 10.0V into the 8 ohm load.
2. Sweep the oscillator frequency from 20Hz to 20KHz. The output voltage of each channel should remain constant within ± 2 dB.

3. Connect a RIAA Pre-Equalizer (if a Pre-Equalizer is not available, conduct test per 7 through 9) to the PHONO input jacks. AFTER reducing the oscillator level to minimum, connect it to the input of the Pre-Equalizer.
4. Set the unit SELECTOR switch in the PHONO position and the VOLUME control to minimum. Remove the Distortion Analyzer from the Output Load Box and connect it to any pair of TAPE OUT jacks.
5. Set the oscillator level for any convenient output voltage (approximately 300mV at the TAPE OUT jacks). Set analyzer for an indication of 0dB.
6. Sweep the oscillator frequency from 20Hz to 20KHz. The output voltage of each channel should remain constant within ± 2 dB.

FREQUENCY RESPONSE TEST WITHOUT RIAA PRE-EQUALIZER -

7. Reduce the oscillator level to minimum. Connect it to the PHONO input jacks.
8. Set test equipment controls and unit controls per 4 and 5, above, except analyzer to be set for 0dB at 1KHz.
9. Sweep oscillator frequency from 20Hz to 20KHz. The output voltage of each channel should follow the curve shown in Figure 6 within ± 2 dB.

Return test equipment to set-up shown in Figure 5.

L. GAIN TEST

1. With the Audio Oscillator connected to the PHONO input jacks, level set to minimum and frequency set to 1KHz ± 10 Hz, set the unit SELECTOR switch to the PHONO position.

(VOLUME control at maximum).
2. Adjust the oscillator level for any convenient output level (between 15 and 20V).
3. Measure the input voltage level. The difference between the input and output signal levels should be 86dB ± 1.0 dB.

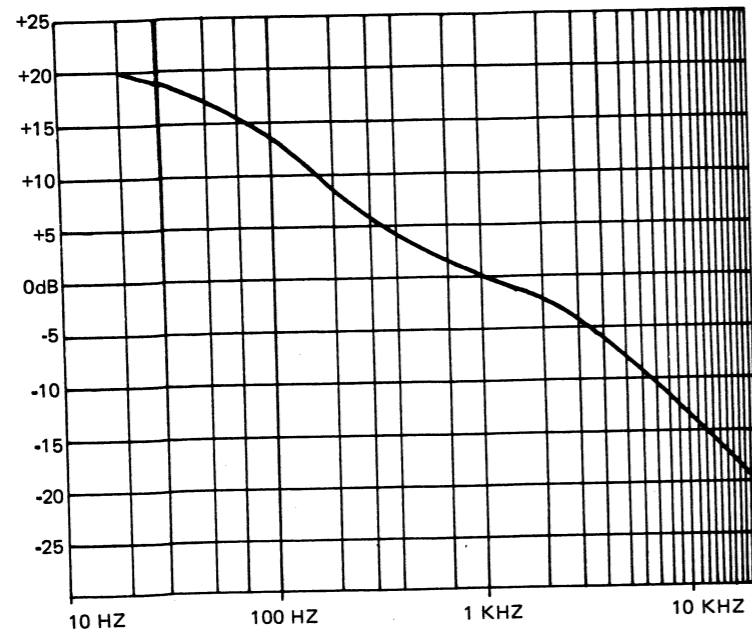

Figure 6. RIAA Equalization Curve

Nominal stage gain:

PHONO in to TAPE OUT: 40dB

AUX in to PREAMP OUT: 20dB

AMP IN to SPEAKER: 26dB

M. CHANNEL SEPARATION TEST

1. Connect the Audio Oscillator to the L Channel AUX input jack, with frequency set to 20KHz. Insert Shorting Plug in the R Channel AUX input jack.
2. With VOLUME control fully C.W. set the SELECTOR switch to AUX.
3. Adjust the oscillator level for any convenient output voltage, into an 8 ohm load (between 15 and 20V).
4. Measure the output of the right channel and verify that it is 40dB or more below the level of the left channel.
5. Repeat test for left channel output with right channel driven.

N. FILTER AND TONE CIRCUIT TEST

1. Connect Audio Oscillator to AUX input jacks of each channel. Set frequency to

RIAA NAB DISK REPRODUCING STD.

20 KHz	-20 dB
15 KHz	-17.17 dB
14 KHz	-16.64 dB
13 KHz	-15.95 dB
12 KHz	-15.28 dB
11 KHz	-14.55 dB
10 KHz	-13.75 dB
9 KHz	-12.88 dB
8 KHz	-11.91 dB
7 KHz	-10.85 dB
6 KHz	-9.62 dB
5 KHz	-8.23 dB
4 KHz	-6.64 dB
3 KHz	-4.76 dB
2 KHz	-2.61 dB
1000	0
700	+1.23 dB
400	+3.81 dB
300	+5.53 dB
200	+8.22 dB
100	+13.11 dB
70	+15.31 dB
50	+16.96 dB
30	+18.61 dB
20 Hz	+20 dB

50Hz and level for any convenient output into the 8 ohm load. Set unit SELECTOR switch to AUX position.

2. Measure output voltage with LOW FILTER switch IN and OUT. Verify a drop of 3dB \pm 1.5dB with switch IN.
3. Reset oscillator frequency to 100Hz. Compare output voltage with BASS control in center detent and at MAX position. Boost should be 10dB \pm 2dB. Verify a 10dB \pm 2dB cut when BASS controls are moved from center to MINIMUM position.
4. Change oscillator frequency to 10KHz. Re-adjust level if necessary. Measure output voltage of each channel. Depress HIGH FILTER switch and verify a 4dB \pm 1.5dB drop in signal level.
5. Adjust TREBLE controls to MAXIMUM. Output voltage should increase by 10dB \pm 2dB as compared to output voltage with controls in detent. Verify a 10dB \pm 2dB drop in output voltage when TREBLE controls are adjusted from center detent to MINIMUM position.

O. LOUDNESS CIRCUIT TEST

1. Connect Audio Oscillator to both channel AUX input jacks. Adjust level for 21.9V output into the 8 ohm load. Adjust unit VOLUME control (from MAXIMUM) for a 30dB reduction in output level.
2. With oscillator frequency at 100Hz, compare output level with LOUDNESS switch IN and OUT. Verify a 7dB \pm 2dB boost with switch IN.
3. Change oscillator frequency to 10KHz. Verify a 7dB \pm 2dB boost in output voltage when LOUDNESS switch is depressed.

2. Switch the Wattmeter IN and set the Variac to 0.
3. Turn the Line Switch ON and slowly advance the Variac to 120 VAC while observing the Wattmeter. The Wattmeter should indicate less than 35W at 120V. If the Wattmeter indicates either 0 or greater than 35W, a defect exists. Turn off the unit and correct the fault.
4. Reduce the unit VOLUME to minimum. Connect a low-range voltmeter across series combination of R553 and R549 (voltmeter in 0-100mV range). See Figure 14 for component and connection point location.
5. Adjust R523 for voltmeter reading between 11 and 18mV.
6. Change location of voltmeter to series combination of R550 and R554. See Figure 14.
7. Adjust R524 for voltmeter reading between 11 and 18mV.

Note: 11mV drop across the series resistance represents 30mA idling current in the output stage. 18mV represents 50mA idling current.

ADJUSTMENT PROCEDURE

A. TEST EQUIPMENT

Refer to Table 1 for recommended test equipment.

B. PRELIMINARY PROCEDURES

The preliminary procedures outlined in the Performance Verification section of this manual are applicable in their entirety.

C. UNIT DISASSEMBLY

Remove the top cover. (See Service Notes section for disassembly instructions).

D. BIAS ADJUST

1. Turn Line Switch to OFF. Rotate the bias adjust potentiometers R523 and R524 fully C.W. (See Figure 14 for component locations).

E. DC BALANCE ADJUST

1. Monitor the left channel output with a VTVM in the DC mode.
2. With the unit VOLUME control set to minimum, adjust the left channel Zero Set potentiometer R517 for a DC output voltage of 0V \pm 50mV. (See Figure 14 for component location).
3. While monitoring the right channel output, adjust the right channel Zero Set potentiometer R518 for a DC output voltage of 0V \pm 50mV.

MODEL 1120

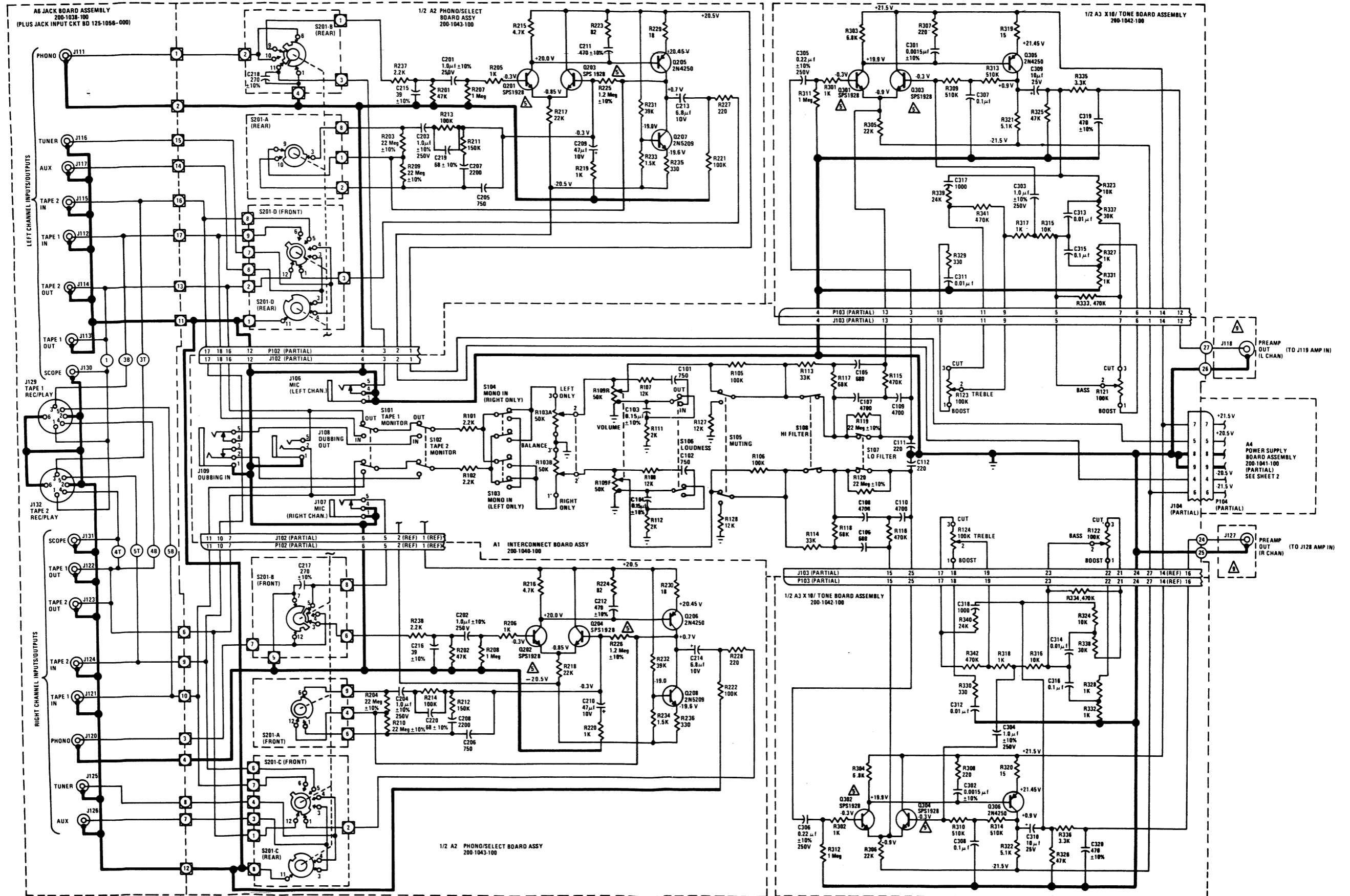

9 Figure 7A. Model 1120 Schematic

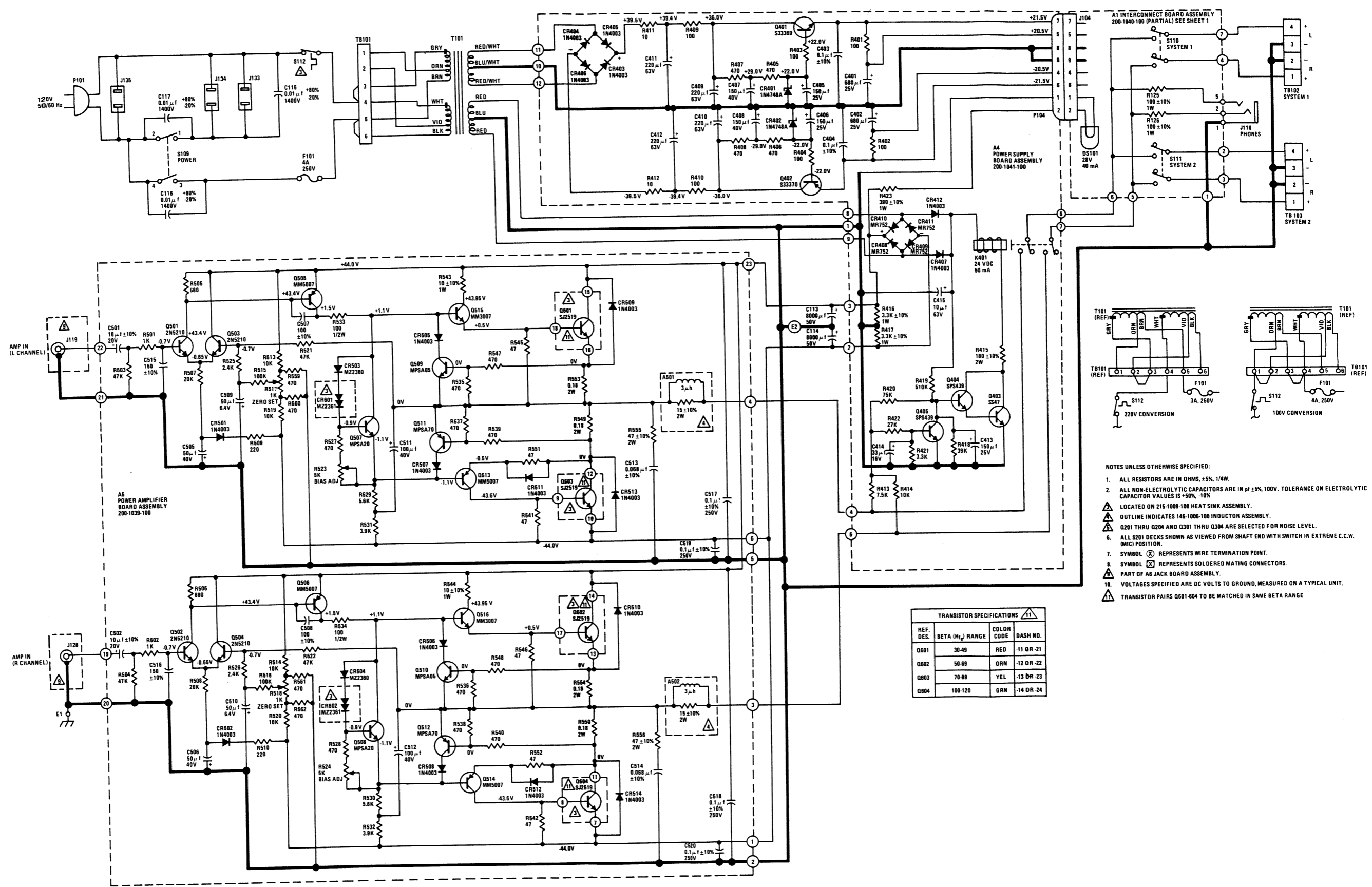

- NOTES UNLESS OTHERWISE SPECIFIED:
1. ALL RESISTORS ARE IN OHMS, $\pm 5\%$, 1/4W.
 2. ALL NON-ELECTROLYTIC CAPACITORS ARE IN μf $\pm 5\%$, 100V. TOLERANCE ON ELECTROLYTIC CAPACITOR VALUES IS $\pm 50\%$, $\pm 10\%$.
 3. LOCATED ON 215-1009-100 HEAT SINK ASSEMBLY.
 4. OUTLINE INDICATES 145-1006-100 INDUCTOR ASSEMBLY.
 5. Q201 THRU Q204 AND Q301 THRU Q304 ARE SELECTED FOR NOISE LEVEL.
 6. ALL S201 DECKS SHOWN AS VIEWED FROM SHAFT END WITH SWITCH IN EXTREME C.C.W. (MIC) POSITION.
 7. SYMBOL \otimes REPRESENTS WIRE TERMINATION POINT.
 8. SYMBOL \boxtimes REPRESENTS SOLDERED MATING CONNECTORS.
 9. PART OF A6 JACK BOARD ASSEMBLY.
 10. VOLTAGES SPECIFIED ARE DC VOLTS TO GROUND, MEASURED ON A TYPICAL UNIT.
 11. TRANSISTOR PAIRS Q601-604 TO BE MATCHED IN SAME BETA RANGE

REF. DES.	BETA (H_{FE}) RANGE	COLOR CODE	DASH NO.
Q601	30-49	RED	-11 OR -21
Q602	50-69	ORN	-12 OR -22
Q603	70-99	YEL	-13 OR -23
Q604	100-120	GRN	-14 OR -24

Figure 7B. Model 1120 Schematic

MODEL 1120

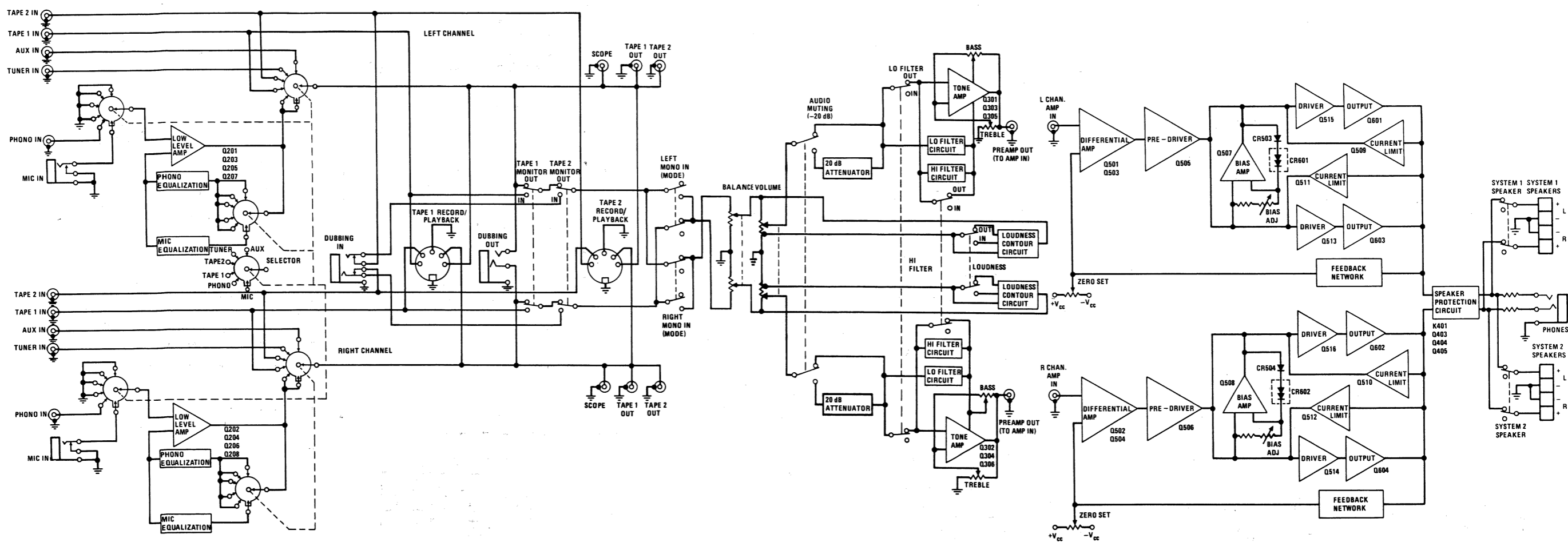

Figure 8. Functional Block Diagram

SERVICE NOTES

This section contains instructions for the disassembly of the Model 1120 into its major component assemblies. Unless otherwise specified in the text, re-assembly of the unit is accomplished by following the instructions in reverse sequence. In all instances where the mounting means is not provided with a locking device (i.e., lockwasher, etc.) apply a small amount of Glyptal (P/N 641-1012-000) to the screw or nut. Included in the instructions for each major assembly are replacement procedures for those items which require special care or whose disassembly/re-assembly process is not obvious. In all cases, read all the instructions prior to attempting service.

Figure 9 shows the location of all major components of the Model 1120 within an assembled unit. Figures 10 through 16 show the location of the components within the input Jack Board Assembly, Phono/Select Board Assembly, Interconnect Board Assembly, X10/Tone Board Assembly, Power Amplifier Board Assembly, Heatsink/Power Amplifier Assembly and the Power Supply Board Assembly, respectively.

This section also outlines the procedure for conversion of 120V units for 100V or 220V operation, and contains a Parts List for items which are not part of a printed circuit board assembly.

A. DISASSEMBLY/RE-ASSEMBLY INSTRUCTIONS

1. Top Cover:

- Remove the nine (9) #6-32 x 1/4 screws (P/N 789-1000-000) from around the periphery of the cover.
- When replacing the Top Cover with a new part, insure that both the Speaker Caution Label (P/N 585-1002-000) and the User Servicing Caution Label (P/N 585-1008-000) are affixed.

2. Heatsink Assembly:

- Remove the Top Cover per paragraph 1.
- Disconnect the seven (7) single-lead connectors along the top edge of the Power Amplifier board and the four (4) single-lead connectors along the bottom edge of the board (the two connectors nearest the power transformer may be removed by using a modified "Solder-Aid" or extended-length long-nose pliers).

- Remove the six (6) #6-32 x 5/16 screws (P/N 741-0512-000) securing the Heatsink Assembly to the chassis rear panel; the screws are located with two (2) on each side of the finned heatsink and one (1) each side near the bottom edge of the rear panel. All screws are equipped with a #6 split spring lockwasher (P/N 671-4332-000).
- Lift the Heatsink Assembly straight up until the bottom edge of the circuit board clears the top of the chassis.
- Disconnect the two (2) wires from the Thermal Switch (P/N 491-1000-000).
- Prior to re-assembly of the Heatsink Assembly to the chassis, coat the mounting flanges of the heatsink with Wakefield Type 120 Thermal Compound (P/N 637-1002-000). Remove excess compound after the Heatsink Assembly is in place.

3. Power Amplifier Board Assembly – A5:

- Remove the Top Cover per paragraph 1.
- Remove the Transistor covers by sliding them towards the top of the heatsink until they are free of their retaining groove.
- Remove the Heatsink Assembly per paragraph 2.
- Remove the (2) #6-32 x 9/16 screws (P/N 741-0910-000) and #6 internal-tooth lock-washer (P/N 672-4410-000) securing each power transistor to the circuit board.
- Unsolder the transistor pins from the circuit board. The circuit board is now free of the heatsink.
- When re-assembling, coat both sides of the mica insulator (P/N 371-1006-000) with a liberal amount of Wakefield Type 120 Thermal Compound (P/N 637-1002-000). Remove excess compound after transistors are in place.
- Prior to re-assembling the circuit board to the heatsink, apply a liberal amount of Thermal Compound to the bodies of the bias diodes (CR601 and CR602 – see Figure 14 for location). Insure

MODEL 1120

that the diodes are firmly seated, along their entire body, against the heatsink.

4. Power Transistors - Q601 thru Q604 (Reference Figure 15):

- Remove the Top Cover per paragraph 1.
- Remove the Transistor covers by sliding them towards the top of the heat-sink until they are free of their retaining groove.
- Remove the two (2) #6-32 x 9/16 screws (P/N 741-0910-000) and #6 internal-tooth lock-washer (P/N 672-4410-000) securing the power transistor to the circuit board.
- Unsolder the transistor pins from the circuit board. The transistor is now free.
- When re-assembling, coat both sides of the mica insulator (P/N 371-1006-000) with a liberal amount of Wakefield Type 120 Thermal Compound (P/N 637-1002-000). Remove excess compound after the transistor is reinstalled.
- If all the power transistors have been removed, it will be necessary to insure that the bias diodes (CR601 and CR602) are properly seated in the heat-sink groove. The diodes are to be in intimate contact with the heatsink over the entire length of their bodies, with Thermal Compound applied over the entire length of the diode where it contacts the heatsink.

5. Bias Diodes – CR601, CR602 (Reference Figure 14):

- Remove the Top Cover per paragraph 1.
- Remove the faulty diode by unsoldering its leads from the special terminals at each end of small opening in the Power Amplifier Board.
- When installing the new diode, bend its leads at right angles to the diode body, with the spacing approximately the same as it was on the old diode.
- Coat the diode body with Wakefield 120 Thermal Compound (P/N

637-1002-000).

- Insert the coated diode through the opening in the circuit board and, while insuring that the diode is in intimate contact with the heatsink groove over the entire length of its body, solder the leads to the special terminal.

6. Front Panel:

- Remove the large knobs (P/N 174-1001-000) from the Selector Switch and Volume control shafts using a #8 hex key wrench (allen wrench) to loosen the set screws (P/N 775-3142-000).
- Pull the knobs (P/N 174-1014-000) off the Tone and Balance controls.
- Remove the #3/8-32 Nuts (P/N 680-8726-000) from the Selector Switch and Volume control threaded bushings.
- When installing a replacement panel, insure that the Dust Mask (P/N 159-1004-000) is secured in place, with the slots in the mask centered over the slots in the panel, using "double-sided" tape (P/N 642-1000-000); that the Pilot Lamp Lens (P/N 170-1002-000) is pressed into place; and the Push Button Bushing (P/N 168-1012-000) is installed in the panel hole for the Power Switch.

7. Phono/Select Board Assembly – A2:

- Remove the Top Cover per paragraph 1.
- Using a #8 hex key wrench (allen wrench), loosen the set screw (P/N 775-3142-000) and remove the Knob (P/N 174-1001-000) from the Selector switch shaft.
- Disconnect the four (4) single-wire connectors from the Interconnect board, adjacent to the Selector switch.
- Disconnect the four (4) single-wire connectors from along the bottom of the Power Amplifier board (the two connectors nearest the power transformer may be removed by using a modified "Solder-Aid" or extended length long nose pliers).

- Remove the solder lug (with wire attached) from the Chassis Ground binding post.
 - Remove the #3/8-32 nut (P/N 680-8726-000) from the Selector switch threaded bushing (at the Selector switch mounting bracket).
 - Remove the four (4) #6-32 x 3/8 screws (P/N 784-6132-000) and #6 split-spring lockwashers (P/N 671-4332-000) that secure the Rear Panel Jack board to the chassis rear apron.
 - Disconnect the Phono/Select Board from the Interconnect Board and withdraw the entire assembly through the access in the rear panel. When the end of the Selector switch shaft is clear of the Interconnect Board, remove the #3/8-32 nut from the shaft.
8. X10/Tone Board Assembly – A3:
- Remove the Top Cover per paragraph 1.
 - Remove the #6-32 x 1/4 screw (P/N 789-1000-000) that secures the circuit board mounting bracket to the chassis base.
 - Disconnect the X10/Tone Board Assembly from the Interconnect Board.
9. Power Supply Board Assembly – A4:
- Remove the Top Cover per paragraph 1.
 - Disconnect the twelve (12) single-wire connectors at the top edge of the circuit board.
 - Remove the #6-32 x 1/4 screw (P/N 789-1000-000) that secures the circuit board mounting bracket to the chassis base.
 - Disconnect the Power Supply Board Assembly from the Interconnect Board.
10. Interconnect Board Assembly:
- Remove the Top Cover per paragraph 1.
 - Remove the Front Panel per paragraph 6.
 - Pull the knob (P/N 174-1017-000) from the Power switch shaft.
 - Disconnect the four (4) single-wire connectors from the Interconnect Board, adjacent to the Selector switch.
 - Disconnect the seven (7) single-wire connectors from the Interconnect Board, directly in front of the power transformer.
 - Remove the two (2) #6-32 x 1/4 screws (P/N 789-1000-000) securing the Selector switch mounting bracket to the chassis base. (Not required on units without front "lip".)
 - Remove the X10/Tone Board Assembly per paragraph 8.
 - Remove the Power Supply Board Assembly per paragraph 9.
 - Loosen (do not remove) the four (4) screws which mount the power transformer.
 - Remove the two (2) #6-32 x 3/8 screws (P/N 784-6132-000) and #6 split-spring lockwashers (P/N 671-4332-000) that secure the outermost edge of the Rear Panel Jack board to the chassis. Loosen (do not remove) the remaining two (2) screws.
 - Remove the two (2) #6-32 x 3/8 screws that secure the chassis rear to the Front/Side panel near the accessory outlets.
 - Remove the eight (8) #6-32 x 1/4 screws (P/N 789-1000-000) securing the Chassis Front/Side Panels to the chassis base (4 screws secure each panel - 2 along the front and 2 at the side).
 - Facing the front of the unit, gently spring the right side panel outward to free it from under the power transformer and to provide clearance between the bottom flange and the power switch, lift the front of the panels enough to clear the "lip" (later units do not have a "lip") at the front

MODEL 1120

of the chassis base and remove the entire assembly (consisting of the Front/Side Panels and the Interconnect Board) from the unit by exerting a steady forward force.

- Remove the #3/8-32 nuts (P/N 680-8726-000) from the bushings of the five (5) phone jacks (Left Mic In, Right Mic In, Dubbing In, Dubbing Out, and Phones) and the Volume control.
- Remove the six (6) #4-40 x 5/16 screws (P/N 721-0512-000) mounting the push-button switch assemblies (2 screws per assembly) to the Front/Side panels.
- Remove the four (4) #6-32 x 1/4 screws (P/N 784-4132-000) which secure the Tone Pot Mounting Bracket.
- Remove the Front/Side Panels from the Interconnect Board.
- Remove the Switch Assembly Spacers (P/N 168-1013-000) from the switch frames.
- Remove the special washers (P/N 675-1011-000) from the five (5) phone jacks.
- When replacing a push-button switch assembly, the knobs (P/N 174-1015-000) should be removed after removing the Front Panel. Caution should be taken that only a steady pulling force is exerted on the knob; sharp "tugs" or "wiggling" of the knob may cause the shaft to become disengaged from the switch.
- When replacing any of the five (5) phone jacks, refer to Detail A of Figure 12 for location of the jack body with respect to the Interconnect Board.
- When replacing the Volume control, refer to Detail B of Figure 12 for location of the control body with respect to the Interconnect Board.

11 Pilot Lamp:

- Remove Top Cover per paragraph 1.
- Unsolder the lamp leads from the Interconnect Board.
- Lift lamp and grommet from the

groove.

- Remove lamp from grommet.

12. Power Transformer:

- Disconnect the transformer secondary leads from the Power Supply Board.
- Disconnect the 2 wires (red and violet) from the terminal strip at the top of the transformers.
- Remove the four (4) #10-32 x 7/16 screws (P/N 761-0712-000), each screw is equipped with a #10 split-spring lockwasher (P/N 671-6572-000) and #10 flat washer (P/N 176-1007-000).
- Remove the transformer and the two Retainer Bars (P/N 137-1010-000).

B. VOLTAGE CONVERSION INSTRUCTIONS

1. 220 - Volt AC Conversion:

- Remove the Top Cover (See Disassembly Instructions).
- Locate TB101, the terminal strip located on the power transformer half-shell facing the rear panel, which terminates the power transformer primary wires (see Figure 9).
- Remove the two bare wire jumpers, leaving the insulated wires intact.
- Install an #18 AWG bare wire jumper to TB101, connecting the grey and violet transformer wires.
- Re-attach the Top Cover.
- Replace the 4-amp, 250V fuse in the unit with the 3-amp, 250V fuse (P/N 451-1001-000) supplied with the 220-volt conversion kit (P/N 105-1011-100).
- Affix labels, supplied in the conversion kit, in the appropriate locations on the unit cover, and adjacent to the line cord, fuse holder and the accessory outlets.

The Model 1120 is now ready for 220-volt operation.

2. 100 - Volt AC Conversion:

MODEL 1120

- Remove the Top Cover (see Disassembly Instructions).
- Locate TB101, the terminal strip located on the power transformer half-shell facing the rear panel, which terminates the power transformer primary wires (see Figure 9).
- Disconnect the red and violet power lead-in wires at TB101 and remove all jumpers from TB101.
- Install two #18 AWG bare-wire jumpers to TB101; one connecting the orange and violet transformer wires, and one connecting the grey and white transformer wires. Connect the red and violet power lead-in wires to the white and orange transformer wires, respectively, at TB101.
- Re-attach the Top Cover.
- Affix the labels, supplied in the 100-volt conversion kit (P/N 105-1012-100), in the appropriate locations on the unit cover, and adjacent to the line cord and the accessory outlets.

The Model 1120 is now ready for 100-volt operation.

C. PARTS LIST

Listed below are those parts (except circuit board assembly components) which might be required for service or maintenance of the Model 1120. Components of circuit board assemblies are contained in separate lists which appear, in this manual, adjacent to the figure depicting the circuit board assembly.

Description	Part Number
Bar, Xfmr Retainer	137-1010-000
Binding Post, Chassis Ground	359-1004-000
Bushing, Push Button	168-1012-000
Capacitor, 8000 mfd, 50V (C113, C114)	381-1079-000
Capacitor, 0.01 mfd, 1400V (C115, C116, C117)	383-1006-000
Compound, Thermal	637-1002-000
Connector, Single-Wire	365-1015-000
Connector Strip, Output	362-1002-000
Cover, Top	136-1035-000
Cover, Transistor	136-1037-000

Description	Part Number
Foot, Plastic	567-1000-000
Fuse, 4-amp, 250V	451-1003-000
Fuse Holder	367-1001-000
Glyptal	641-1012-000
Insulator, Mica (TO-3)	371-1006-000
Knob, Large	174-1001-000
Knob, Power Switch	174-1017-000
Knob, Push Button	174-1015-000
Knob, Tone & Balance Control	174-1014-100
Label, Speaker Caution	585-1002-000
Label, User Servicing Caution	585-1008-000
Lens, Light	170-1002-000
Line Cord	361-1007-000
Manual, Owner's	199-1090-000
Mask, Dust	159-1004-000
Nut, #4-40 Clip	682-2000-000
Nut, #3/8-32 Hex.	680-8726-000
Packing Set	198-1031-000
Panel, Front	134-1030-000
Plug Assy, Molded	360-1027-000
Plug, Phono-Self Shorting	360-1008-000
Schematic, Unit	199-1100-000
Screw, Set, #8-32 x 1/4	775-3142-000
Screw, #4-40 x 5/16, Blk	721-0512-000
Screw, #6-32 x 1/4, Thread-Forming, Blk	784-4132-000
Screw, #6-32 x 1/4, Sems, Thread-Forming, Blk	789-1000-000
Screw, #6-32 x 5/16, Blk	741-0512-000
Screw, #6-32 x 5/16, Thread-Forming, Blk	784-5132-000
Screw, #6-32 x 3/8, Blk	741-0612-000
Screw, #6-32 x 1/2, Cad	741-0810-000
Screw, #10-32 x 7/16, Blk	761-0712-000
Spacer, Switch Assy	168-1013-000
Switch, Power (S109)	452-1016-000
Tape, Double Coated	642-1000-000
Template, Mounting	199-1082-000
Terminal Strip (TB101)	362-1006-000
Transformer, Power	440-1012-000
Washer, #4 Split-Spring Lock	671-2232-000
Washer, #6 External-Tooth Lock	673-4400-000
Washer, #6 Split-Spring Lock	671-4432-000
Washer, #10 Flat	176-1007-000
Washer, #10 Split-Spring Lock	671-6572-000
Washer, Phone Jack	675-1011-000

MODEL 1120

X

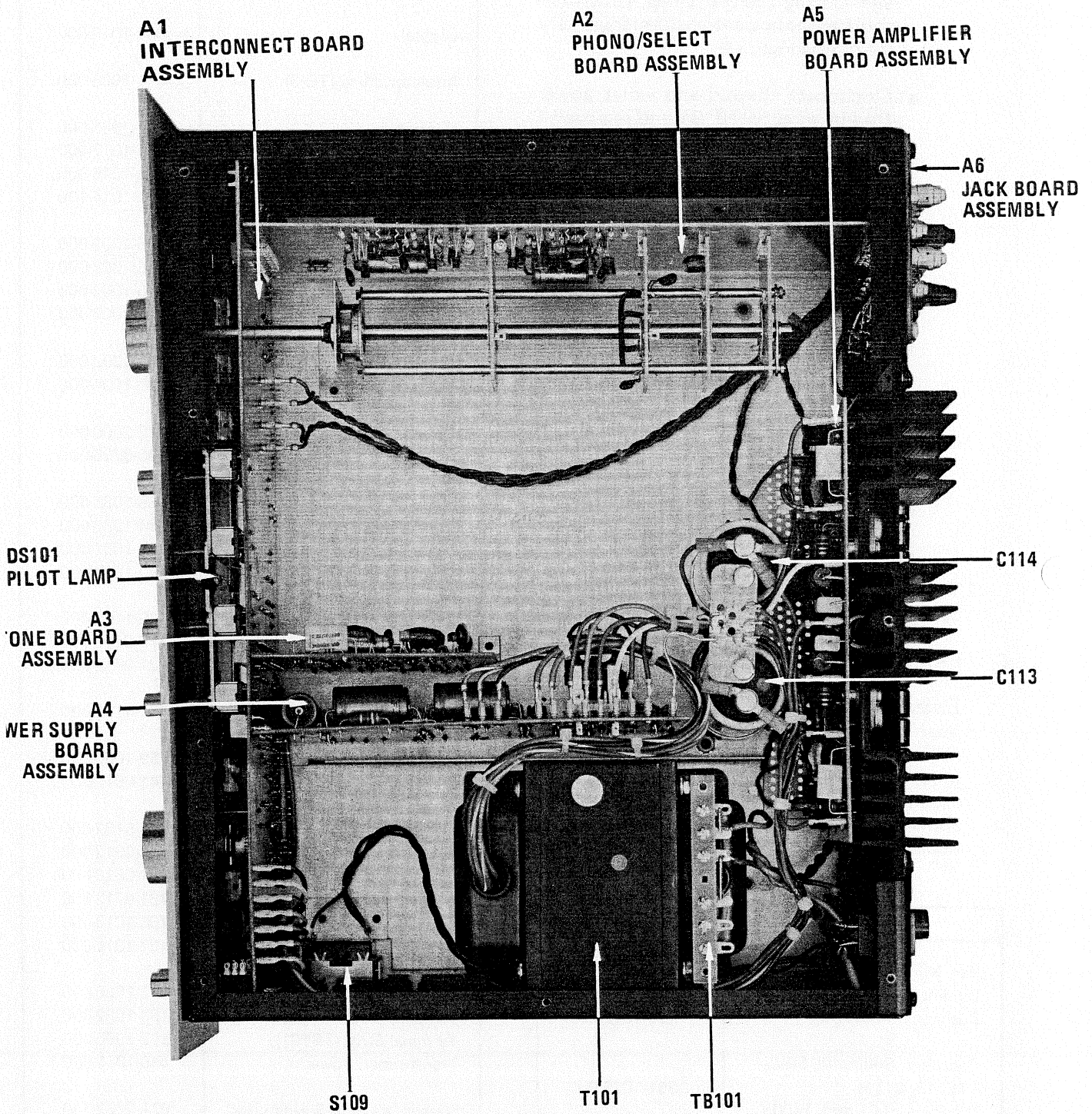

Figure 9. Model 1120 Interior View

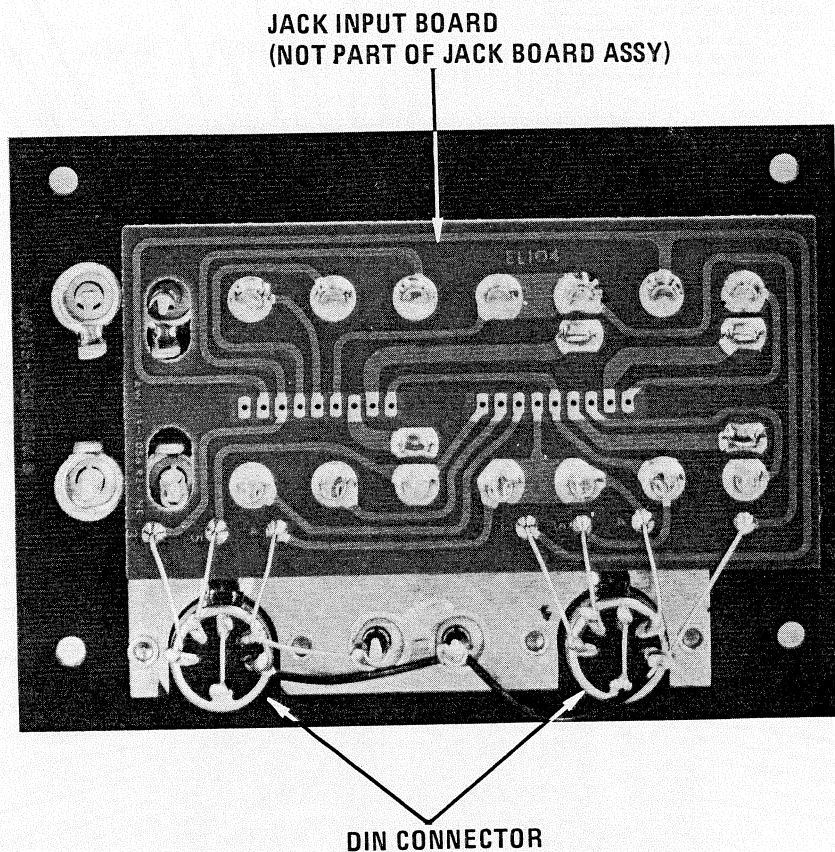

Figure 10. Jack Panel Board Assembly

JACK PANEL BOARD ASSY PARTS LIST

Description	Part Number
Jack Panel Board Assy (A6)	200-1038-100
Circuit Board, Jack Input*	125-1056-000
Connector Receptacle - DIN	360-1016-000
Jack, Input	360-1029-000
Rivet, 1/8 Dia x 3/16 Lg	655-4066-000
Spacer, Nylon*	677-1007-000
Terminal	365-2006-000
*Indicates parts not included in Jack Panel Board Assy	

MODEL 1120

NOTES:

1. All voltages are dc volts to ground, measured on a typical unit.
2. Configuration shown is applicable to circuit boards fabricated from A/W 115-1043, Rev. C.

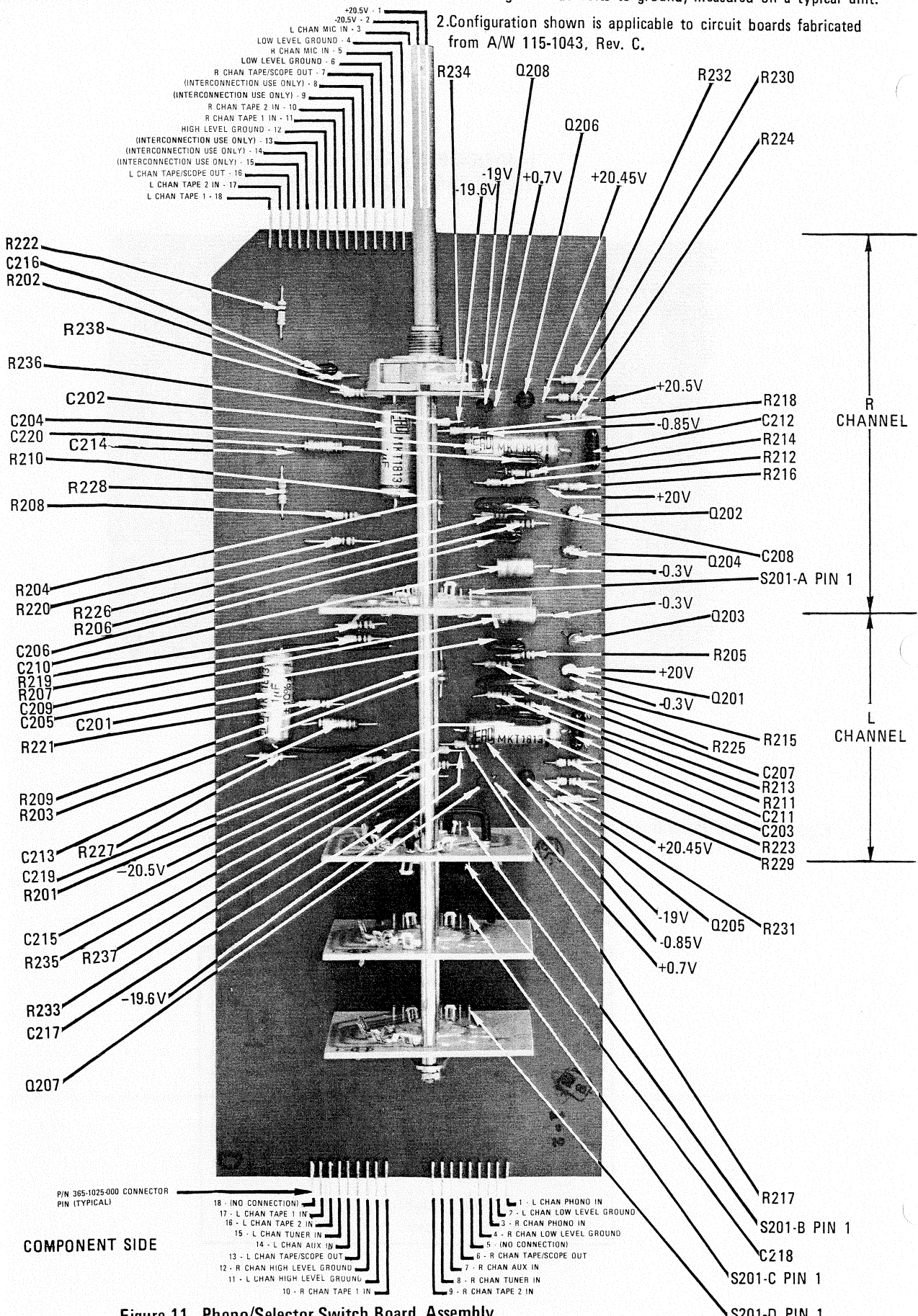
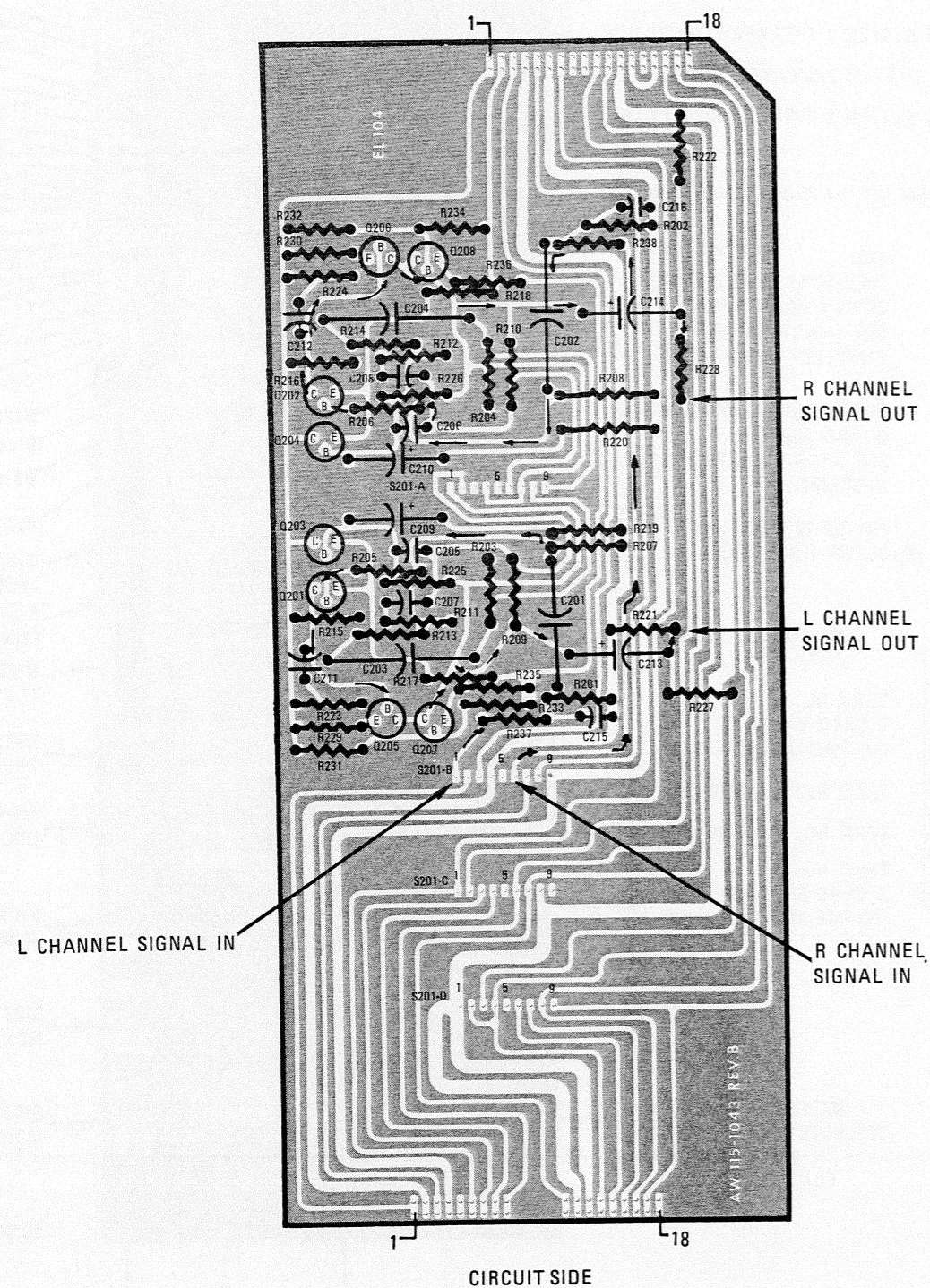

Figure 11. Phono/Selector Switch Board Assembly

PHONO/SELECTOR BOARD ASSY PARTS LIST



Des.	Description	Part Number
A2	Phono/Selector Board Assembly	200-1043-100
C201, 202	Cap., 1 μ f \pm 10%, 250V	386-1034-000
C203, 204	Cap., 1 μ f \pm 10%, 250V	386-1034-000
C205, 206	Cap., 750 pf \pm 5%, 100V	385-1077-000
C207, 208	Cap., 2200 pf \pm 5%, 100V	385-1089-000
C209, 210	Cap., Elect. 47 μ f, 10V	381-1037-000
C211, 212	Cap., 470 pf \pm 10%, 100V	385-1087-000
C213, 214	Cap., Elect. 6.8 μ f, 10V	381-1083-000
C215, 216	Cap., 39 pf \pm 10%, 100V	385-1053-000
C217, 218	Cap., 270 pf \pm 10%, 100V	385-1037-000
C219, 220	Cap., 68 pf \pm 10%, 100V	385-1074-000
Q201, 202	Transistor, NPN	462-1038-100
Q203, 204	Transistor, NPN	462-1038-100
Q205, 206	Transistor, PNP	461-1013-000
Q207, 208	Transistor, NPN	462-1063-000
R201, 202	Res., 47K \pm 5%, 1/4W	434-5472-000
R203, 204	Res., 22M \pm 10%, 1/4W	421-8223-000
R205, 206	Res., 1K \pm 5%, 1/4W	434-4102-000
R207, 208	Res., 1M \pm 5%, 1/4W	434-7102-000
R209, 210	Res., 22M \pm 10%, 1/4W	421-8223-000
R211, 212	Res., 150K \pm 5%, 1/4W	434-6152-000
R213, 214	Res., 100K \pm 5%, 1/4W	434-6102-000
R215, 216	Res., 4.7K \pm 5%, 1/4W	434-4472-000
R217, 218	Res., 22K \pm 5%, 1/4W	434-5222-000
R219, 220	Res., 1K \pm 5%, 1/4W	434-4102-000
R221, 222	Res., 100K \pm 5%, 1/4W	434-6102-000
R223, 224	Res., 82 Ω \pm 5%, 1/4W	434-2822-000
R225, 226	Res., 1.2M \pm 10%, 1/4W	434-7123-000
R227, 228	Res., 220 Ω \pm 5%, 1/4W	434-3222-000
R229, 230	Res., 18 Ω \pm 5%, 1/4W	434-2182-000
R231, 232	Res., 39K \pm 5%, 1/4W	434-5392-000
R233, 234	Res., 1.5K \pm 5%, 1/4W	434-4152-000
R235, 236	Res., 330 Ω \pm 5%, 1/4W	434-3332-000
R237, 238	Res., 2.2K \pm 5%, 1/4W	434-4222-000
S201	Switch	453-1026-000
	Connector, Male-"F" Pin	360-1025-000

Figure 11. Phono/Selector Switch Board Assembly (Cont.)

MODEL 1120

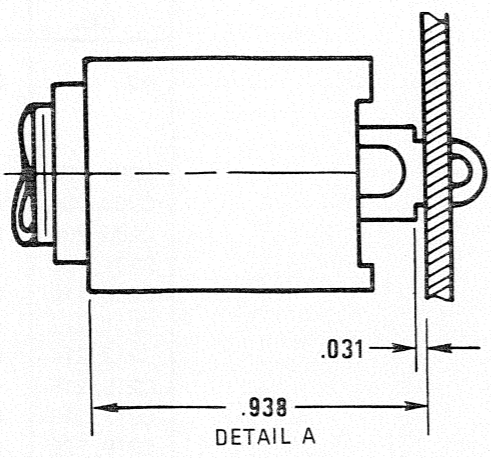
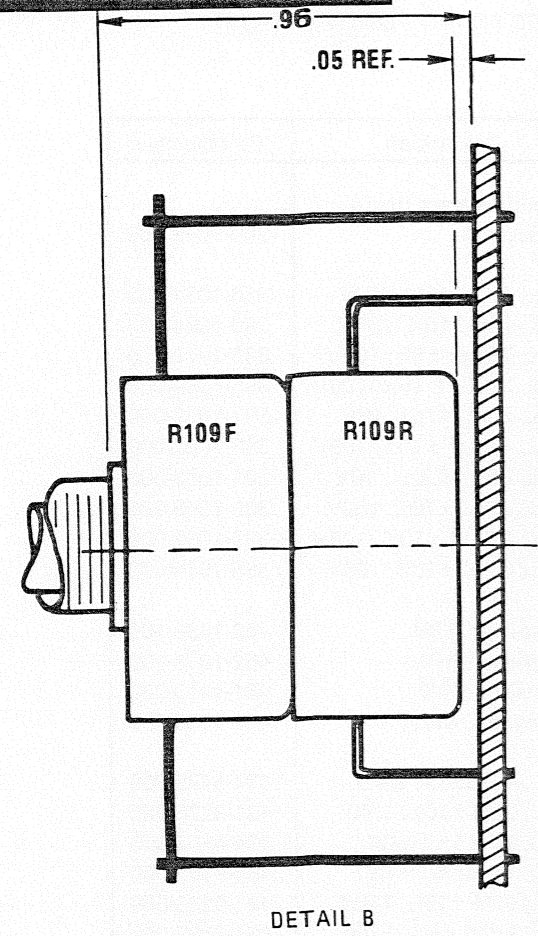

- Notes:
- Configuration shown is applicable to circuit boards fabricated from A/W 115-1040, Rev. N/C.
 - J106 thru J110 to be installed per Detail A.
 - R109 to be installed per Detail B
 - Screws to be secured in place with P/N 641-1012-000 Insulating Varnish (Walsco NO. 134-08 Red GLPT).

CONNECTOR PIN FUNCTION CHART			
J102-1	+20.5V	J103-1	-21.5V
-2	-20.5V	-2	(INTERCONNECTION USE ONLY)
-3	L CHAN MIC IN	-3	L CHAN SIG IN
-4	LOW LEVEL GROUND	-4	L CHAN GROUND
-5	R CHAN MIC IN	-5	L CHAN BASS CONTROL WIPER
-6	LOW LEVEL GROUND	-6	L CHAN BASS CONTROL (BOOST)
-7	R CHAN TAPE/SCOPE OUT	-7	L CHAN BASS CONTROL (CUT)
-8	(INTERCONNECTION USE ONLY)	-8	(NO CONNECTION)
-9	(INTERCONNECTION USE ONLY)	-9	L CHAN TREBLE CONTROL WIPER
-10	R CHAN TAPE 2 IN	-10	L CHAN TREBLE CONTROL (BOOST)
-11	R CHAN TAPE 1 IN	-11	L CHAN TREBLE CONTROL (CUT)
-12	HIGH LEVEL GROUND	-12	L CHAN SIG OUT
-13	(INTERCONNECTION USE ONLY)	-13	L CHAN FILTER FEEDBACK
-14	(INTERCONNECTION USE ONLY)	-14	+21.5V
-15	(INTERCONNECTION USE ONLY)	-15	R CHAN FILTER FEEDBACK
-16	L CHAN TAPE/SCOPE OUT	-16	R CHAN SIG OUT
-17	L CHAN TAPE 2 IN	-17	R CHAN TREBLE CONTROL (CUT)
-18	L CHAN TAPE 1 IN	-18	R CHAN TREBLE CONTROL (BOOST)
		-19	R CHAN TREBLE CONTROL WIPER
		-20	(NO CONNECTION)
		-21	R CHAN BASS CONTROL (CUT)
		-22	R CHAN BASS CONTROL (BOOST)
		-23	R CHAN BASS CONTROL WIPER
		-24	R CHAN GROUND
		-25	R CHAN SIG IN
		-26	(INTERCONNECTION USE ONLY)
		-27	-21.5V

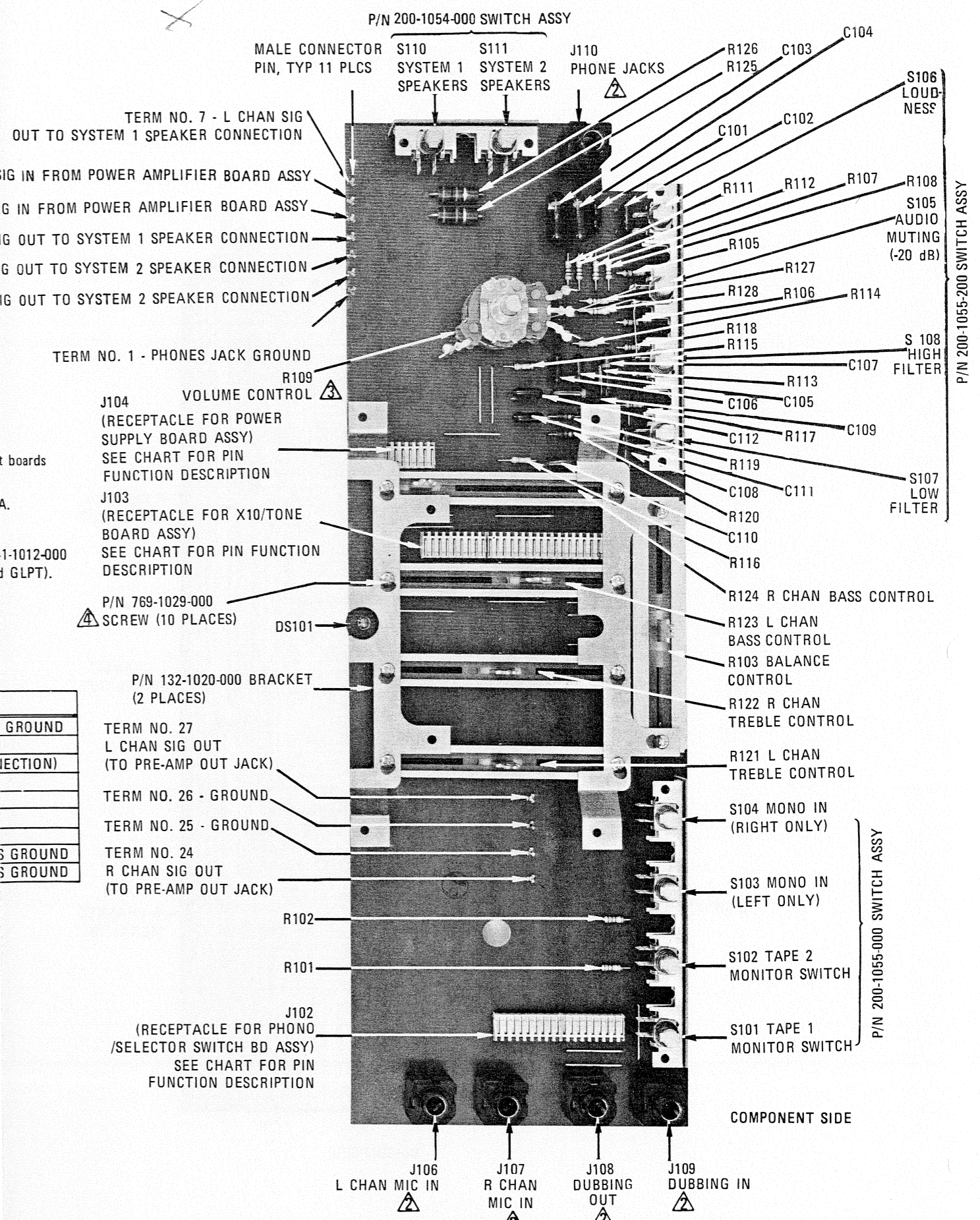

Figure 12. Interconnection Board Assembly

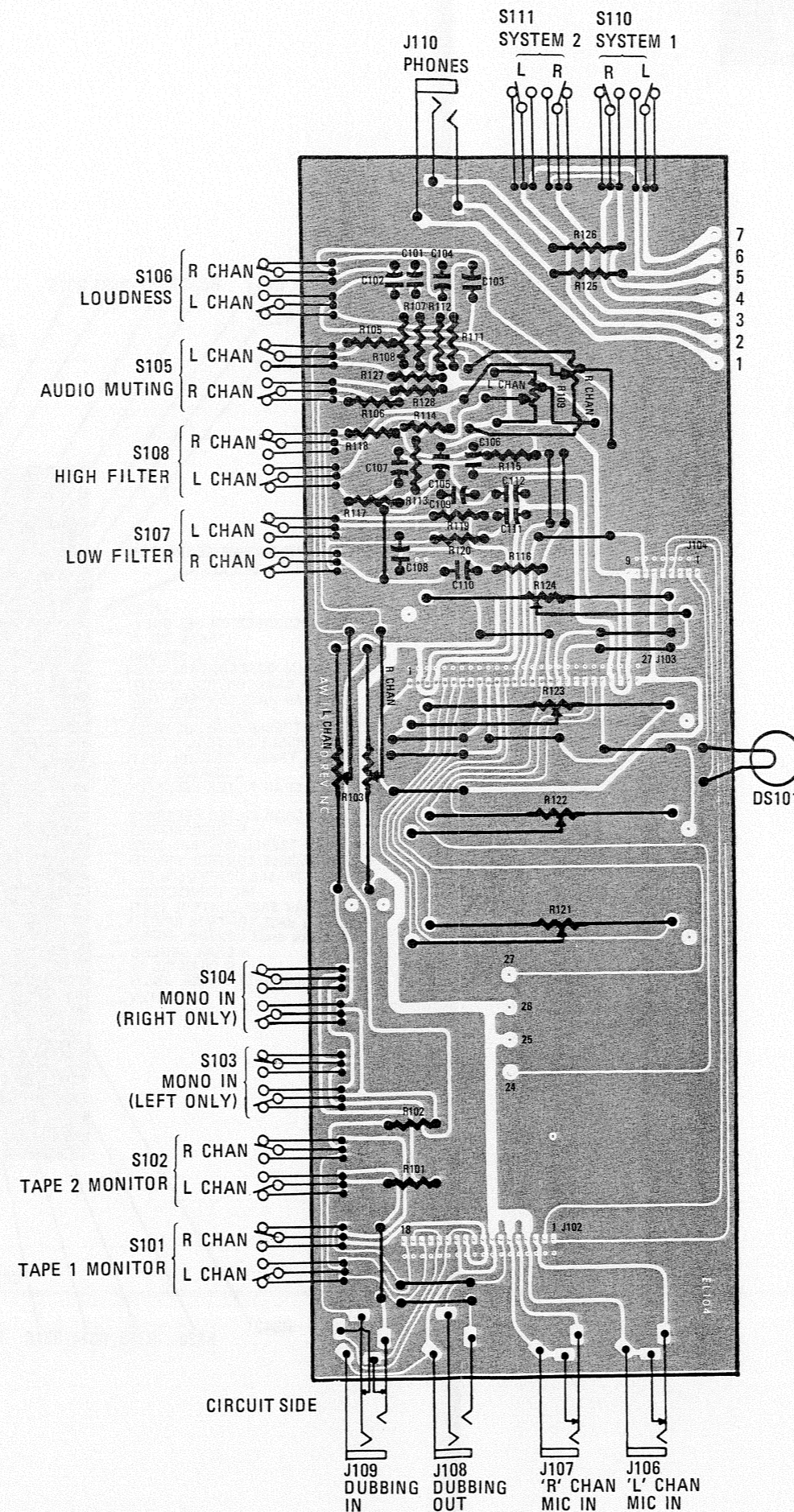
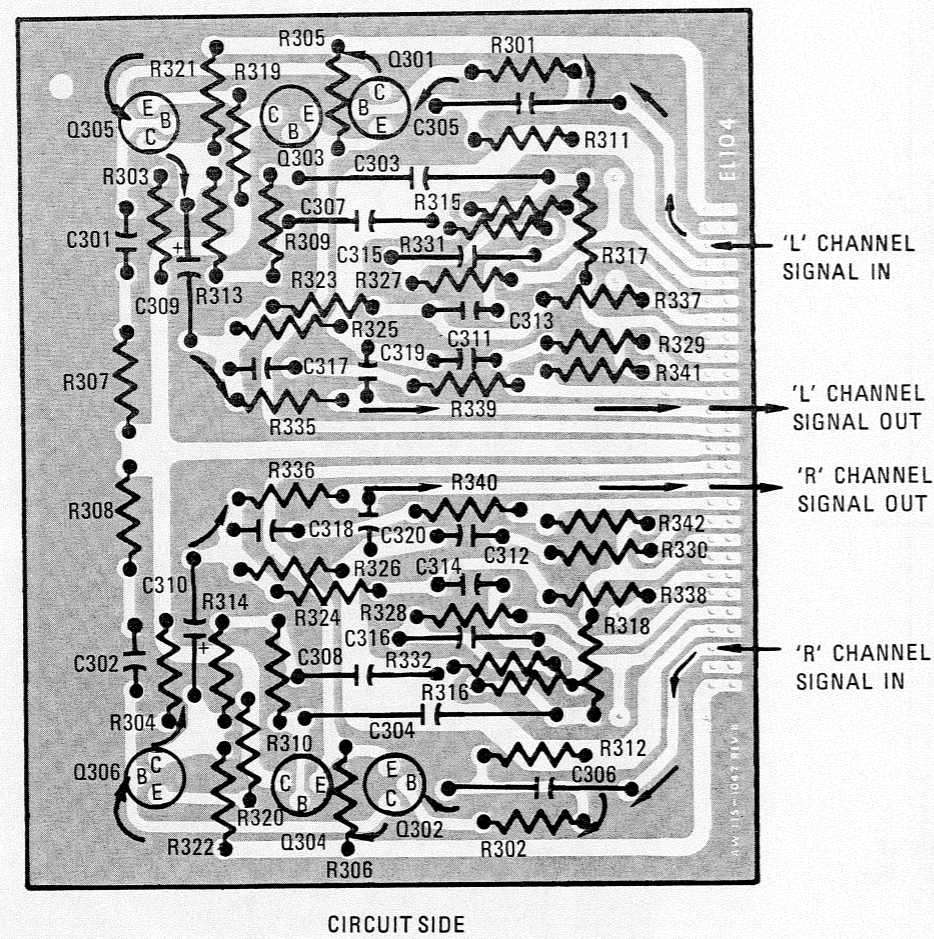

Figure 12. Interconnection Board Assembly (Cont.)

Des.	Description	Part Number
A1	Interconnection Board Assembly	200-1040-100
C101, 102	Cap., 750 pf ±5%, 100V	385-1077-000
C103, 104	Cap., 0.15 μf ±10%, 100V	385-1078-000
C105, 106	Cap., 680 pf ±5%, 100V	385-1042-000
C107, 108	Cap., 4700 pf ±5%, 100V	385-1080-000
C109, 110	Cap., 4700 pf ±5%, 100V	385-1080-000
C111, 112	Cap., 220 pf ±5%, 100V	385-1081-000
DS101	Lamp	482-1007-000
J106, 107	Phone Jack, Single Closed Circuit	360-1017-000
J108	Phone Jack, Double Open Circuit	360-1005-000
J109	Phone Jack, Double Closed Circuit	360-1004-000
J110	Phone Jack, Double Open Circuit	360-1005-000
R101, 102	Res., 2.2K ±5%, 1/4W	434-4222-000
R103	Res., Var., Dual Slide, 50K	420-1027-000
R104	(Not Used)	
R105, 106	Res., 100K ±5%, 1/4W	434-6102-000
R107, 108	Res., 12K ±5%, 1/4W	434-5122-000
R109	Res., Var., Tandem, 50K	420-1032-000
R110	(Not Used)	
R111, 112	Res., 2K ±5%, 1/4W	434-4202-000
R113, 114	Res., 33K ±5%, 1/4W	434-5332-000
R115, 116	Res., 470K ±5%, 1/4W	434-6472-000
R117, 118	Res., 68K ±5%, 1/4W	434-5682-000
R119, 120	Res., 22M ±10%, 1/4W	421-8223-000
R121, 122	Res., Var., Slide, 100K	420-1028-000
R123, 124	Res., Var., Slide, 100K	420-1028-000
R125, 126	Res., 100 Ω ±10%, 1W	423-3103-000
R127, 128	Res., 12K ±5%, 1/4W	434-5122-000
S101-104	Switch Assy, Horiz.	200-1055-000
S105-108	Switch Assy, Horiz.	200-1055-200
S110, 111	Switch Assy, Vert.	200-1054-000
	Bracket, Tone/Balance Pot Mounting	132-1030-000
	Connector, Female-9 Pin	360-1032-000
	Connector Pin	365-1014-000
	Grommet	566-1020-000
	Screw, 3MM Th'd x 3MM Lg	769-1029-000
	Wire, 2 Cond. Shielded	811-2250-000

X10/TONE BOARD ASSEMBLY PARTS LIST



Des.	Description	Part Number
A3	X10/Tone Board Assembly	200-1042-100
C301, 302	Cap., 0.0015 μ f \pm 10%, 100V	385-1094-000
C303, 304	Cap., 1 μ f \pm 10%, 250V	386-1034-000
C305, 306	Cap., 0.22 μ f \pm 10%, 250V	386-1001-000
C307, 308	Cap., 0.1 μ f \pm 5%, 100V	386-1033-000
C309, 310	Cap., Elect., 10 μ f, 25V	381-1034-000
C311, 312	Cap., 0.01 μ f \pm 5%, 100V	385-1092-000
C313, 314	Cap., 0.01 μ f \pm 5%, 100V	385-1092-000
C315, 316	Cap., 0.1 μ f \pm 5%, 100V	386-1033-000
C317, 318	Cap., 1000 pf \pm 5%, 100V	385-1091-000
C319, 320	Cap., 470 pf \pm 10%, 100V	385-1087-000
Q301, 302	Transistor, NPN	462-1038-200
Q303, 304	Transistor, NPN	462-1038-200
Q305, 306	Transistor, PNP	461-1013-000
R301, 302	Res., 1K \pm 5%, 1/4W	434-4102-000
R303, 304	Res., 6.8K \pm 5%, 1/4W	434-4682-000
R305, 306	Res., 22K \pm 5%, 1/4W	434-5222-000
R307, 308	Res., 220 Ω \pm 5%, 1/4W	434-3222-000
R309, 310	Res., 510K \pm 5%, 1/4W	434-6512-000
R311, 312	Res., 1M \pm 5%, 1/4W	434-7102-000
R313, 314	Res., 510K \pm 5%, 1/4W	434-6512-000
R315, 316	Res., 10K \pm 5%, 1/4W	434-5102-000
R317, 318	Res., 1K \pm 5%, 1/4W	434-4102-000
R319, 320	Res., 15 Ω \pm 5%, 1/4W	434-2152-000
R321, 322	Res., 5.1K \pm 5%, 1/4W	434-4512-000
R323, 324	Res., 10K \pm 5%, 1/4W	434-5102-000
R325, 326	Res., 47K \pm 5%, 1/4W	434-5472-000
R327, 328	Res., 1K \pm 5%, 1/4W	434-4102-000
R329, 330	Res., 330 Ω \pm 5%, 1/4W	434-3332-000
R331, 332	Res., 1K \pm 5%, 1/4W	434-4102-000
R333, 334	Res., 470K \pm 5%, 1/4W	434-6472-000
R335, 336	Res., 3.3K \pm 5%, 1/4W	434-4332-000
R337, 338	Res., 30K \pm 5%, 1/4W	434-5302-000
R339, 340	Res., 24K \pm 5%, 1/4W	434-5242-000
R341, 342	Res., 470K \pm 5%, 1/4W	434-6472-000
	Bracket, Mounting	132-1004-000
	Connector, Male-"F" Pin	360-1025-000
	Rivet, 1/8 Dia x 3/16 Lg	655-4066-000

Figure 13. X10/Tone Board Assembly (Cont.)

MODEL 1120

COMPONENT SIDE

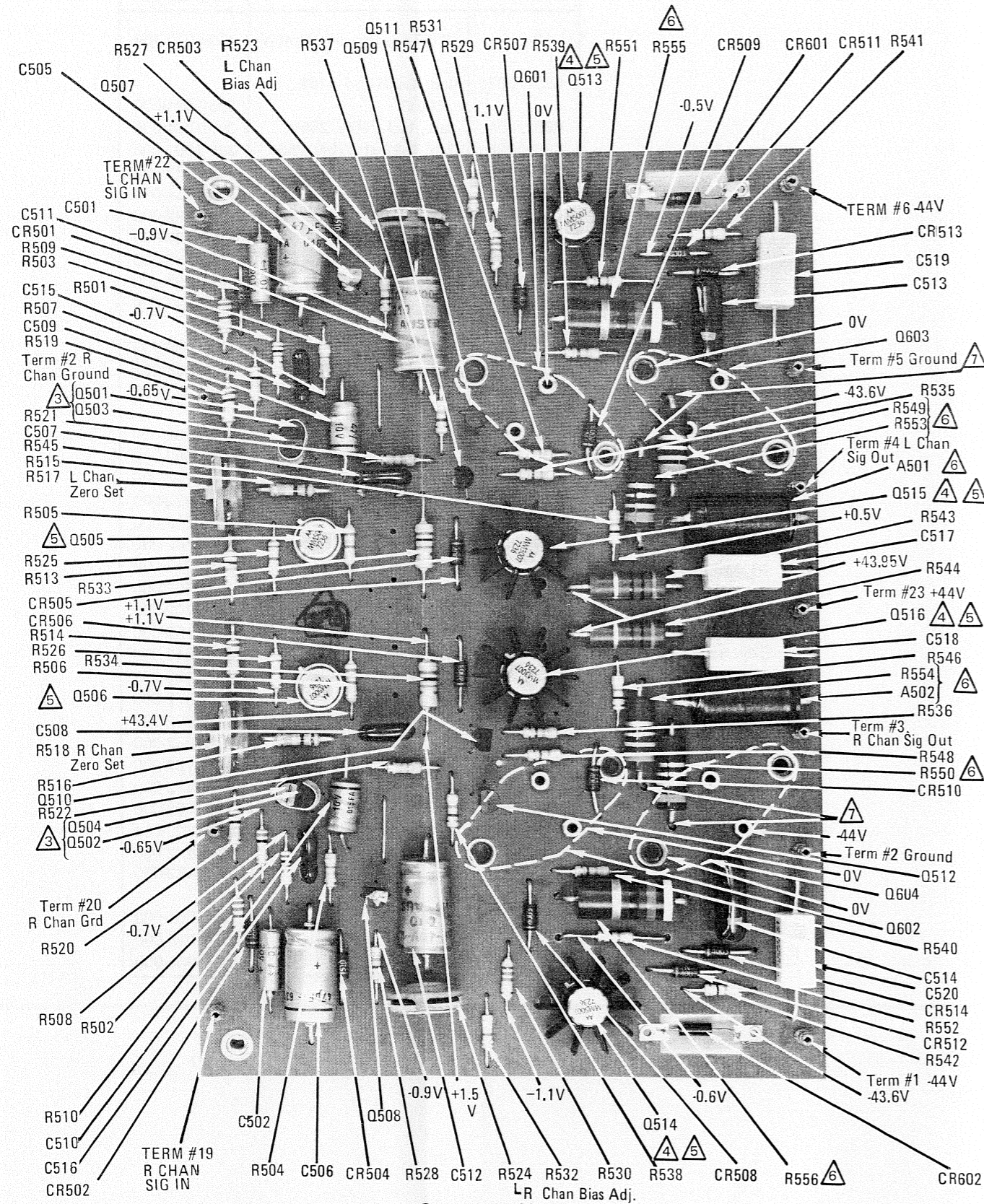

Figure 14. Power Amplifier Board Assembly

Notes:

- ①
- ②
- ③

① Voltages are dc volts to ground, measured on a typical unit.
 ② Configuration shown is applicable to circuit boards fabricated from A/W 115-1039, Rev. A.
 ③ Transistor pairs Q501-Q503 and Q502-Q504 to be equally spaced off board with their entire flat surfaces in intimate contact. P/N 562-1005-000 Thermal Retainer to be installed on each pair.

- ④
- ⑤
- ⑥
- ⑦

④ P/N 562-1000-000 Heat Dissipater to be installed on Q513, Q514, Q515 and Q516.
 ⑤ P/N 372-1000-000 Insulator to be installed under Q505, Q506, Q513, Q514, Q515 and Q516.
 ⑥ A501, A502, R549, R550, R553, R554, R555 and R556 to be installed 1/8" minimum off board.
 ⑦ Points indicated are those used for voltmeter connection during bias adjustment.

LEFT CHANNEL

RIGHT CHANNEL

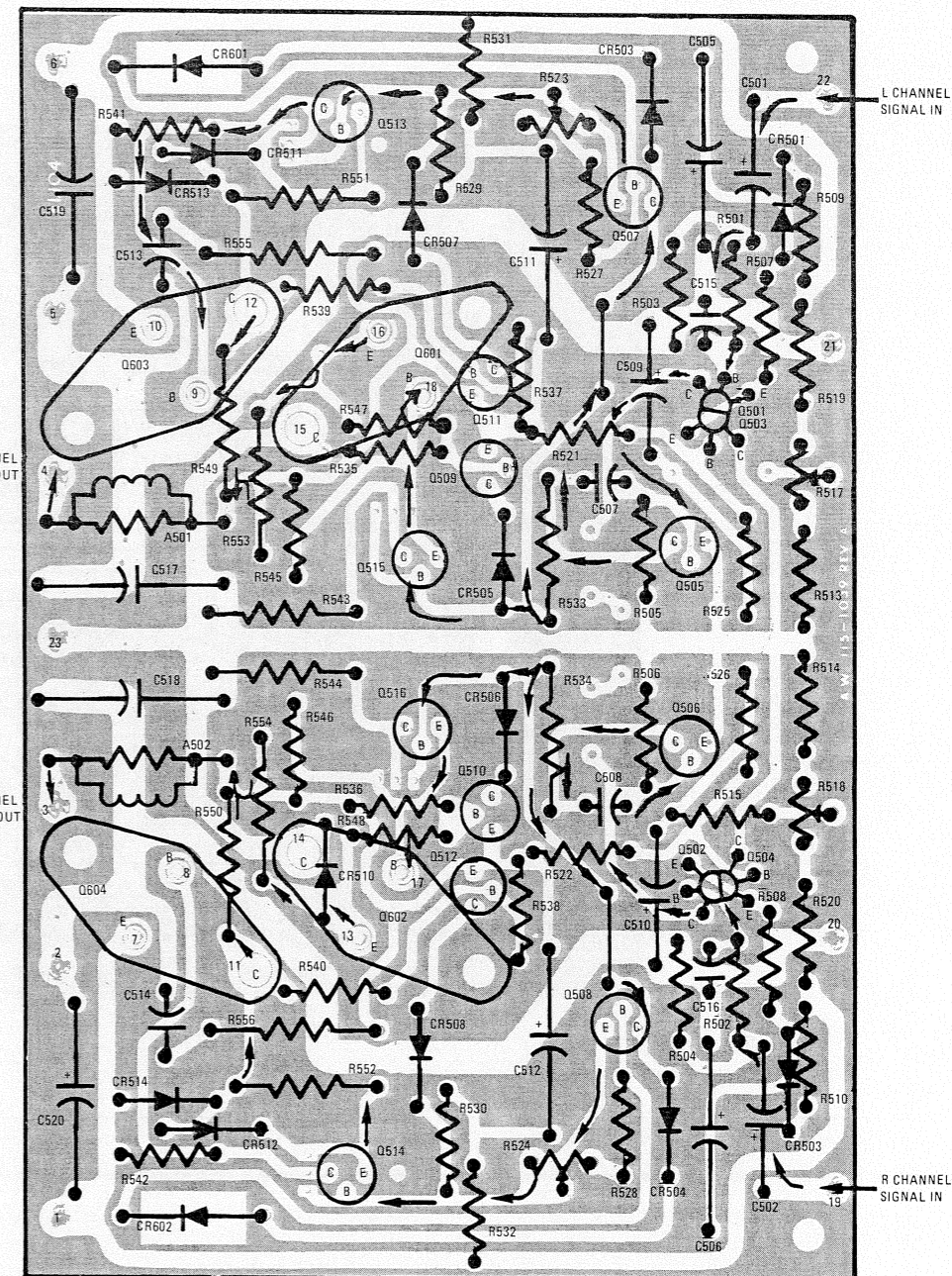

CIRCUIT SIDE

Figure 14. Power Amplifier Board Assembly (Cont.)

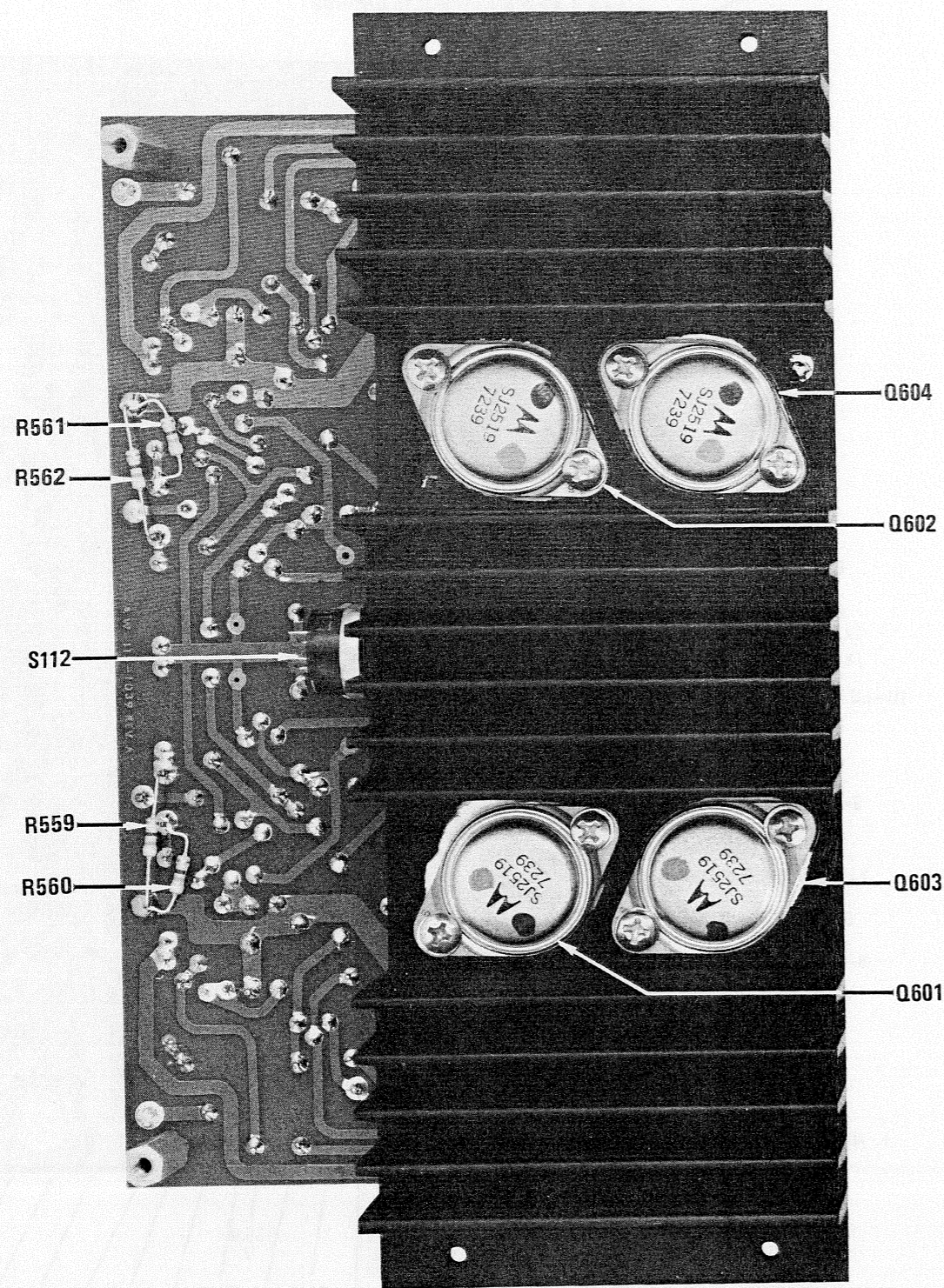

Figure 15. Heatsink/Power Amplifier Assembly

HEATSINK/POWER AMPLIFIER BOARD ASSY PARTS LIST

Des.	Description	Part Number
A5	Power Amplifier Board Assembly	200-1039-100
A501, 502	Resistor, Inductor Assy	145-1006-000
C501, 502	Cap., Elect., 10 μ f \pm 10%, 20V	381-1068-000
C503, 504	(Not Used)	
C505, 506	Cap., Elect., 50 μ f, 40V	381-1071-000
C507, 508	Cap., 100 pf \pm 10%, 100V	385-1041-000
C509, 510	Cap., Elect., 50 μ f, 6.4V	381-1012-000
C511, 512	Cap., Elect., 100 μ f, 40V	381-1013-000
C513, 514	Cap., 0.068 μ f \pm 10%, 100V	385-1093-000
C515, 516	Cap., 150 pf \pm 10%, 100V	385-1038-000
C517, 518	Cap., 0.1 μ f \pm 10%, 250V	386-1000-000
C519, 520	Cap., 0.1 μ f \pm 10%, 250V	386-1000-000
CR501, 502	Diode	460-1013-000
CR503, 504	Diode	460-1005-000
CR505, 506	Diode	460-1013-000
CR507, 508	Diode	460-1013-000
CR509, 510	Diode	460-1013-000
CR511, 512	Diode	460-1013-000
CR513, 514	Diode	460-1013-000
CR601, 602	Diode	460-1015-000
Q501, 502	Transistor, NPN	462-1059-000
Q503, 504	Transistor, NPN	462-1059-000
Q505, 506	Transistor, PNP	461-1051-000
Q507, 508	Transistor, NPN	462-1009-000
Q509, 510	Transistor, NPN	462-1061-000
Q511, 512	Transistor, PNP	461-1006-000
Q513, 514	Transistor, PNP	461-1051-000
Q515, 516	Transistor, NPN	462-1062-000
Q601, 602	Transistor, NPN	462-1036-*
Q603, 604	Transistor, NPN	462-1036-*
R501, 502	Res., 1K \pm 5%, 1/4W	434-4102-000
R503, 504	Res., 47K \pm 5%, 1/4W	434-5472-000
R505, 506	Res., 680 Ω \pm 5%, 1/4W	434-3682-000
R507, 508	Res., 20K \pm 5%, 1/4W	434-5202-000
R509, 510	Res., 220 Ω \pm 5%, 1/4W	434-3222-000
R511, 512	(Not Used)	
R513, 514	Res., 10K \pm 5%, 1/4W	434-5102-000
R515, 516	Res., 100K \pm 5%, 1/4W	434-6102-000
R517, 518	Res., Variable, 1K	420-1030-000
R519, 520	Res., 10K \pm 5%, 1/4W	434-5102-000
R521, 522	Res., 47K \pm 5%, 1/4W	434-5472-000
R523, 524	Res., Variable, 5K	420-1037-000
R525, 526	Res., 2.4K \pm 5%, 1/4W	434-4242-000
R527, 528	Res., 470 Ω \pm 5%, 1/4W	434-3472-000
R529, 530	Res., 5.6K \pm 5%, 1/4W	434-4562-000
R531, 532	Res., 3.9K \pm 5%, 1/4W	434-4392-000
R533, 534	Res., 100 Ω \pm 5%, 1/2W	433-3102-000

R535, 536	Res., 470 Ω \pm 5%, 1/4W	434-3472-000
R537, 538	Res., 470 Ω \pm 5%, 1/4W	434-3472-000
R539, 540	Res., 470 Ω \pm 5%, 1/4W	434-3472-000
R541, 542	Res., 47 Ω \pm 5%, 1/4W	434-2472-000
R543, 544	Res., 10 Ω \pm 10%, 1W	423-2103-000
R545, 546	Res., 47 Ω \pm 5%, 1/4W	434-2472-000
R547, 548	Res., 470 Ω \pm 5%, 1/4W	434-3472-000
R549, 550	Res., 0.18 Ω \pm 5%, 2W	436-0182-000
R551, 552	Res., 47 Ω \pm 5%, 1/4W	434-2472-000
R553, 554	Res., 0.18 Ω \pm 5%, 2W	436-0182-000
R555, 556	Res., 47 Ω \pm 10%, 2W	424-2473-000
R557, 558	(Not Used)	
R559-560	Res., 470 Ω \pm 5%, 1/4W	434-3472-000
R561, 562	Res., 470 Ω \pm 5%, 1/4W	434-3472-000
S112	Switch, Thermal	491-1000-000
	Bushing, Xstr Mounting Compound, Thermal	677-1006-000
	Connector Pin	365-1014-000
	Heatsink, Main	141-1011-000
	Heatsink (TO-5)	562-1000-000
	Insulator (TO-3)	371-1006-000
	Insulator (TO-5)	372-1000-000
	Retainer, Thermal (TO-92)	562-1005-000
	Screw, #6-32 x 9/16, Cad	741-0910-000
	Spacer, 1/8 Lg	560-4020-000
	Spacer, 7/8 Lg	560-4110-000
	Washer, #6 Int. Tooth, Lock	672-4410-000

*FOR APPLICABLE DASH NO., SEE TRANSISTOR SPECIFICATION CHART AND ASSOCIATED NOTES ON SHEET 2 OF UNIT SCHEMATIC (Figure 7.)

MODEL 1120

POWER SUPPLY BOARD ASSY PARTS LIST

Des.	Description	Part Number
A4	Power Supply Board Assembly	200-1041-100
C401, 402	Cap., Elect., 680 μ f, 25V	381-1009-000
C403, 404	Cap., 0.1 μ f \pm 10%, 100V	386-1036-000
C405, 406	Cap., Elect., 150 μ f, 25V	381-1080-000
C407, 408	Cap., Elect., 150 μ f, 40V	381-1085-000
C409, 410*	Cap., Elect., 220 μ f, 63V	381-1086-000
C411, 412*	Cap., Elect., 220 μ f, 63V	381-1086-000
C413	Cap., Elect., 150 μ f, 25V	381-1080-000
C414	Cap., Elect., 33 μ f, 16V	381-1035-000
C415	Cap., Elect., 10 μ f, 63V	381-1033-000
CR401, 402	Diode, Zener	459-1009-000
CR403, 404	Diode	460-1013-000
CR405, 406	Diode	460-1013-000
CR407	Diode	460-1013-000
CR408, 409	Diode	460-1014-000
CR410, 411	Diode	460-1014-000
CR412	Diode	460-1013-000
K401	Relay, DPDT	410-1000-000
Q401	Transistor, NPN	462-1019-000
Q402	Transistor, PNP	461-1014-000
Q403	Transistor, NPN	462-1007-000
Q404, 405	Transistor, NPN	462-1000-000
R401, 402	Res., 100 Ω \pm 5%, 1/4W	434-3102-000
R403, 404	Res., 100 Ω \pm 5%, 1/4W	434-3102-000
R405, 406	Res., 470 Ω \pm 5%, 1/4W	434-3472-000
R407, 408	Res., 470 Ω \pm 5%, 1/4W	434-3472-000
R409, 410	Res., 100 Ω \pm 5%, 1/4W	434-3102-000
R411, 412	Res., 10 Ω \pm 5%, 1/4W	434-2102-000
R413	Res., 7.5K \pm 5%, 1/4W	434-4753-000
R414	Res., 10K \pm 5%, 1/4W	434-5102-000
R415	Res., 180 Ω \pm 10%, 2W	424-3183-000
R416	Res., 3.3K \pm 10%, 1W	423-4333-000
R417	Res., 3.3K \pm 10%, 1W	423-4333-000
R418	Res., 39K \pm 5%, 1/4W	434-5392-000
R419	Res., 510K \pm 5%, 1/4W	434-6512-000
R420	Res., 75K \pm 5%, 1/4W	434-5752-000
R421	Res., 3.3K \pm 5%, 1/4W	434-4332-000
R422	Res., 27K \pm 5%, 1/4W	434-5272-000
R423	Res., 390 Ω \pm 10%, 1W	423-3393-000
	Bracket, Mounting	569-1001-000
	Connector, Male "F" Pin	360-1025-000
	Connector Post	365-1014-000
	Heatsink (TO-5)	562-1000-000
	Insulator, Mounting (TO-5)	372-1000-000

*C409 thru C412 may be 330 μ f in some units.
Use P/N 381-1086-000 for replacement.

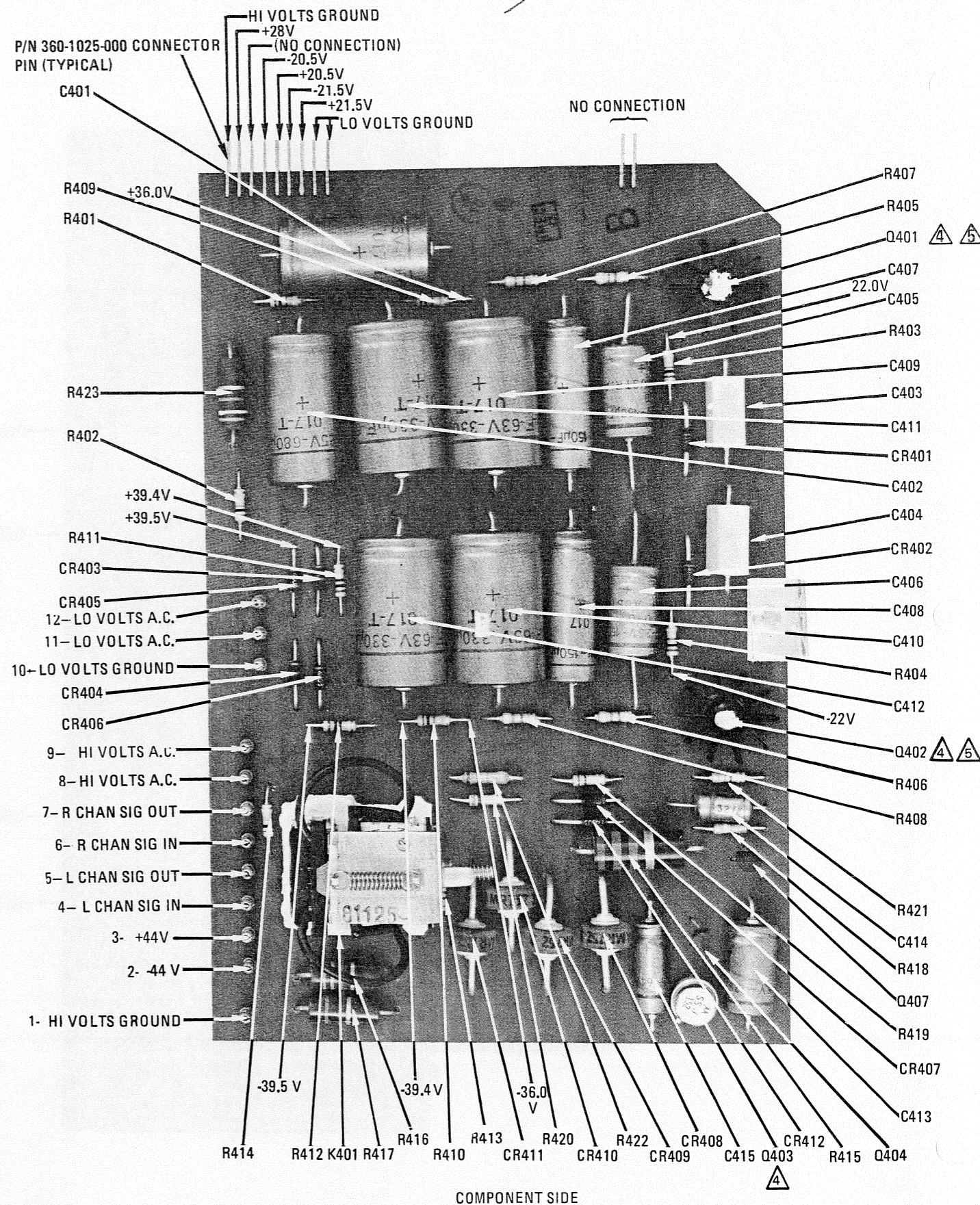

Figure 16. Power Supply Board Assembly

Notes:

1. All voltages are dc volts to ground, measured on a typical unit.
2. Configuration shown is applicable to circuit boards fabricated from A/W 115-1041, Rev. C.
3. R415, CR408, CR409, CR410 and CR411 to be installed 1/8" minimum off board.



P/N 372-1000-000 Insulator to be installed under Q401, Q402 and Q403



P/N 562-1000-000 Heat Dissipater to be installed on Q401 and Q402.

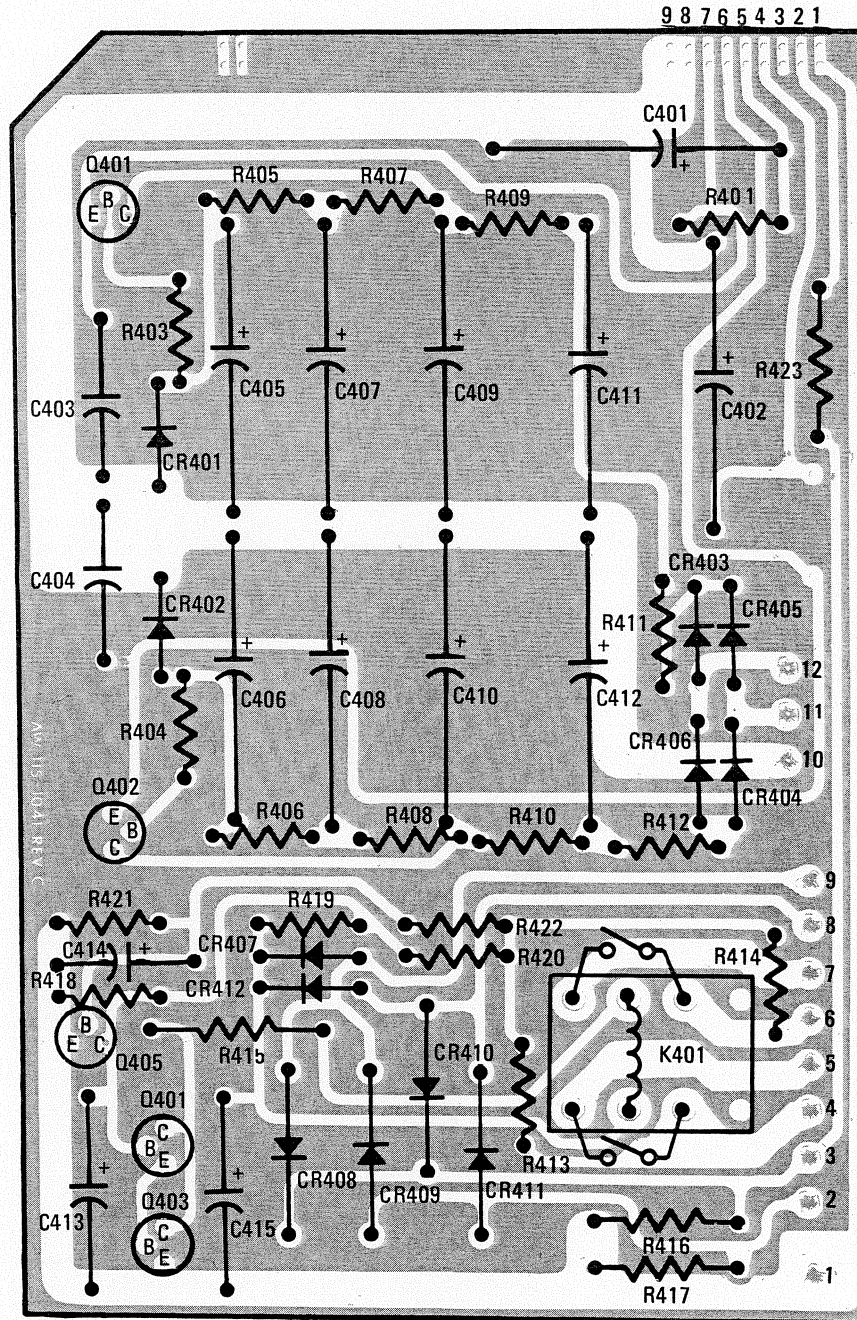

CIRCUIT SIDE

Figure 16. Power Supply Board Assembly (Cont.)