

# marantz.

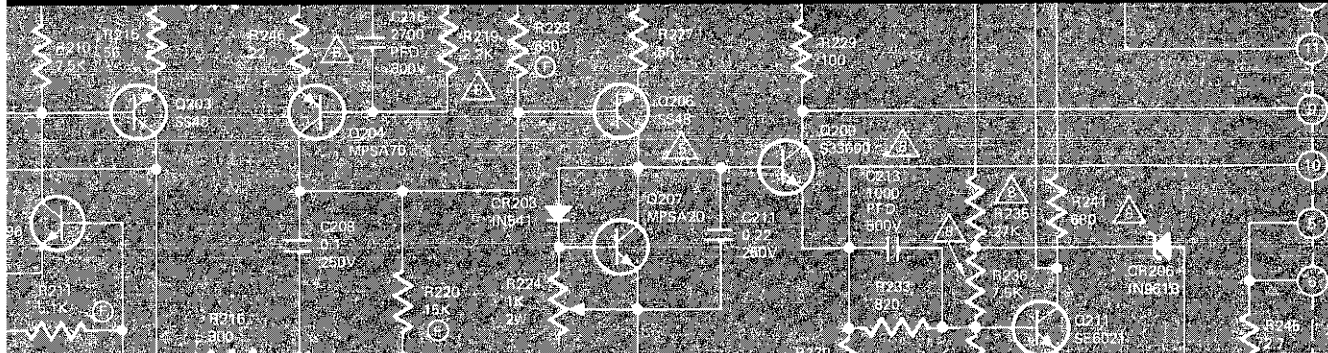

## MODEL 1200

## SERVICE MANUAL

## 1200

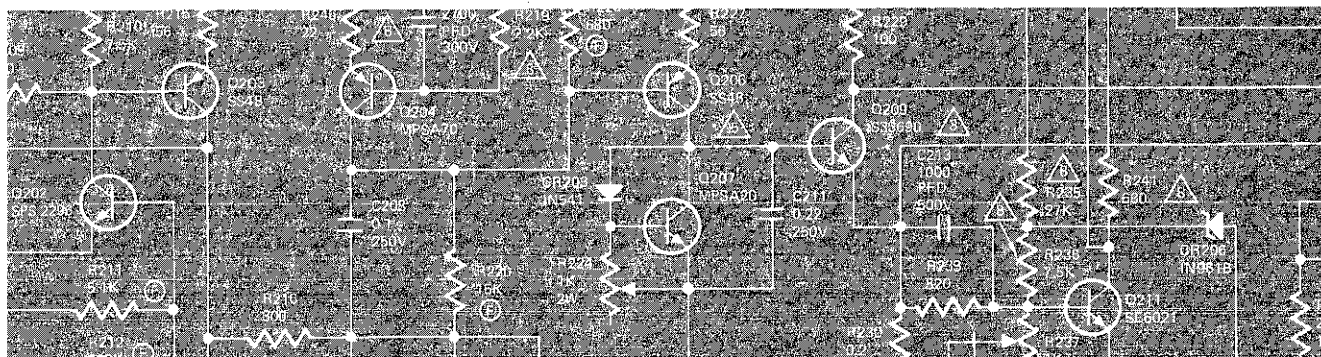

## *Stereo Console Amplifier*

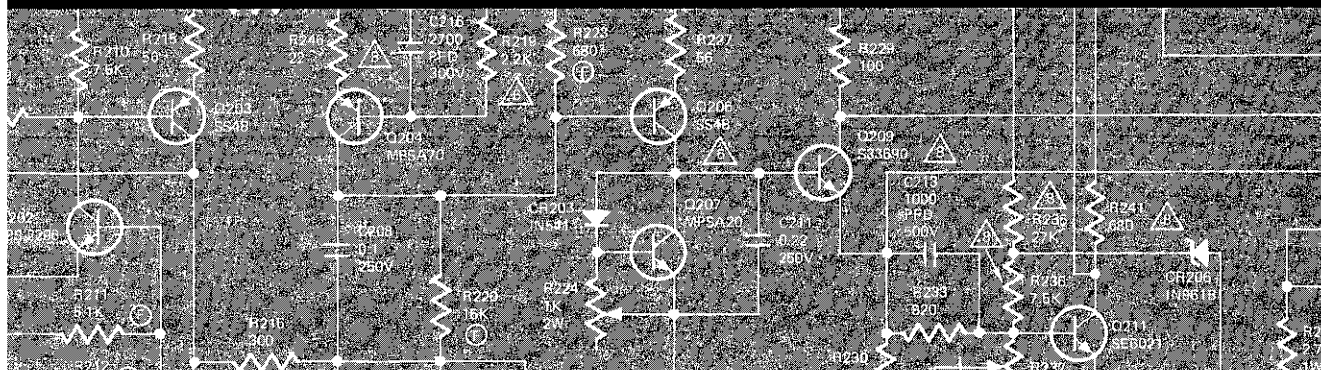

# TABLE OF CONTENTS

<b>SECTION</b>	<b>PAGE</b>
Introduction	1
Circuit Description	1
Technical Specifications	11
220/100-Volt Conversion	13
Performance Verification	13
Trouble Analysis	18
Parts List	20
Component Assembly Diagrams	26
Schematic	34

# LIST OF ILLUSTRATIONS

<b>FIGURE</b>		<b>PAGE</b>
1.	Low Level Amplifier Simplified Schematic	2
2.	X10 Amplifier Simplified Schematic	3
3.	Filter Response Curve	4
4.	Tone Amplifier Simplified Schematic	5
5.	Amplifier Simplified Schematic	6
6.	Tone Control Response Curves	8
7.	Rectifier/Relay Board Simplified Schematic	9
8.	RIAA Equalization Curve	10
9.	Power Supply Simplified Schematic	10
10.	AC Power Control Box Simplified Schematic	17
11.	Amplifier Output Load Box Simplified Schematic	17
12.	Test Equipment Set-Up	19
13.	Interconnect Board – A1 Component Assembly Diagram	26
14.	Phono Amplifier Board – A2 Component Assembly Diagram	28
15.	X10 Amplifier Board – A3 Component Assembly Diagram	29
16.	Tone Amplifier Board – A4 Component Assembly Diagram	30
17.	Power Amplifier Board – A5/A6 Component Assembly Diagram	31
18.	Power Supply Board – A7 Component Assembly Diagram	32
19.	Rectifier/Relay Board – A8 Component Assembly Diagram	33
20.	Model 1200 Schematic, A	34
21.	Model 1200 Schematic, B	36
<b>TABLE</b>		<b>PAGE</b>
1.	Test Equipment Required for Servicing	12

## INTRODUCTION

This service manual is intended for use by authorized warranty stations. The manual contains service information for the Marantz Model 1200 Stereo Console Amplifier, manufactured by The Marantz Company, a subsidiary of Superscope Incorporated, Sun Valley, California 91352.

Adjustment, maintenance, and troubleshooting information listed herein should be attempted only by the experienced technician, one knowledgeable in solid state amplifier operation and the use of test equipment. All instructions should be read carefully and understood fully before proceeding with any service.

Symptoms (and their remedies) listed in the troubleshooting section, are those which might occur in some units. As the Marantz Company becomes aware of other field problems, supplementary service bulletins will be issued to all stations. To improve this service, all problems (and their solutions) not covered in this service manual should be brought to the attention of the National Service Manager at our Sun Valley location.

## CIRCUIT DESCRIPTION

The following circuit description will be based on Channel A only. Both channels of the BALANCE and VOLUME controls, TONE CONTROL switch, and DUBBING IN and DUBBING OUT jacks function simultaneously; thus, both channels will be shown in diagrams. HIGH and LOW filter switches are ganged for both channels, but only channel A will be shown.

### PRE-AMPLIFIER

Program source signals from the 6 jacks (3 low level and 3 high level) on the rear panel are supplied to the SELECTOR switch, Figure 1. The

3 low-level inputs are applied to the low-level amplifier. A section of the SELECTOR switch selects the appropriate (Flat, RIAA) equalization network. The low-level amplifier comprises a single-ended differential amplifier (Q205, Q206), an inverter (Q207), and an emitter-follower (Q208). This amplifier provides a gain of 40dB. The output of the low-level amplifier is applied to another section of the SELECTOR switch.

This section of the SELECTOR switch applies either the output of the low-level amplifier or one of the high-level inputs to the TAPE MONITOR switch, the TAPE OUT jacks, and the DUBBING OUT jack.

The TAPE MONITOR switch applies either the TAPE IN or program source signals to the DUBBING IN jack. This jack contains a built-in switch which disconnects the TAPE IN signals when a plug is inserted into the jack. The signal from the DUBBING IN jack is applied to the MODE switch. This switch applies A, B, STEREO, STEREO REVERSE, or A + B signals to the BALANCE CONTROL.

The BALANCE control is a full range control that permits full attenuation of either channel without affecting the other channel. The output of this control is applied to the VOLUME control. This precision tracking control maintains the stereo balance dictated by the BALANCE control within 3dB from maximum to 50dB from maximum. The output of the VOLUME control is applied to the pre-amplifier (X10 amplifier).

The X10 amplifier, Figure 2, comprises a single-ended differential amplifier (Q404, Q405) and an inverter (Q406). The frequency response of the X10 amplifier is affected by the high and low filters. These filters are controlled by the three position HIGH and LOW filter switches. The filter outputs are applied as negative feedback to Q405. The filters' effect on the frequency response of the unit is shown in Figure 3. The X10 amplifier

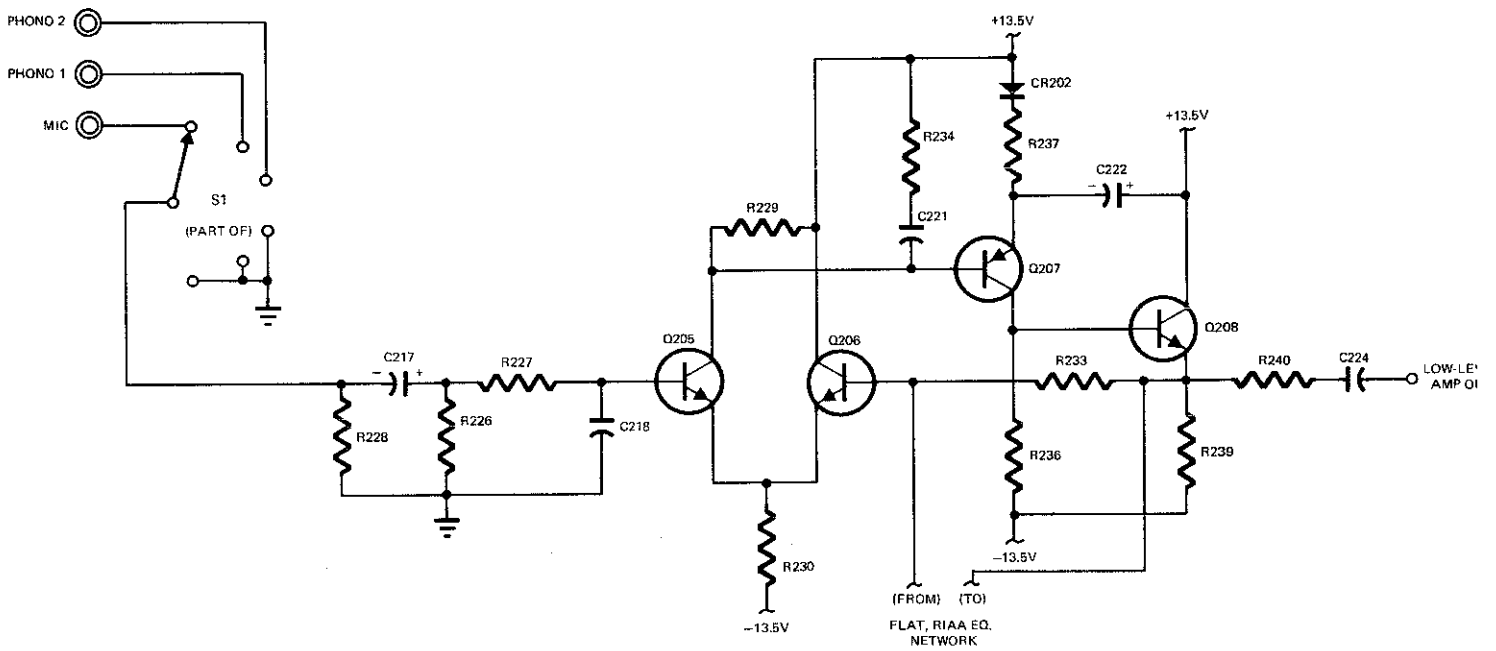

Figure 1. Low Level Amplifier Simplified Schematic.

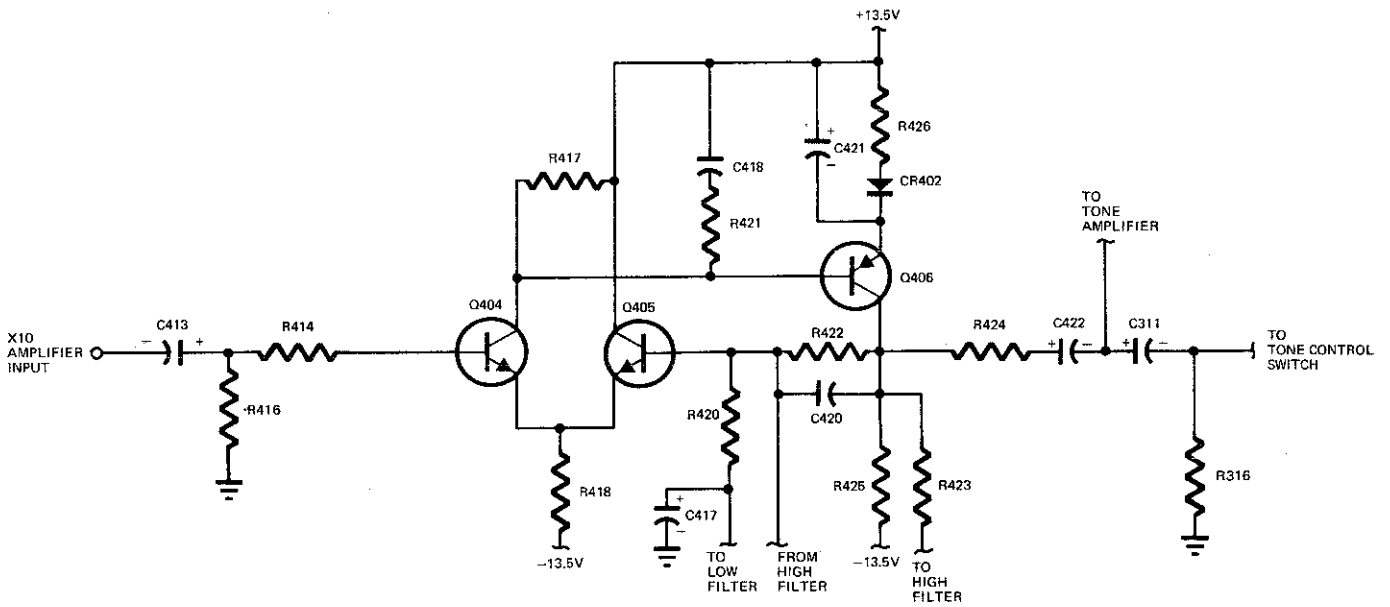

Figure 2. X10 Amplifier Simplified Schematic.

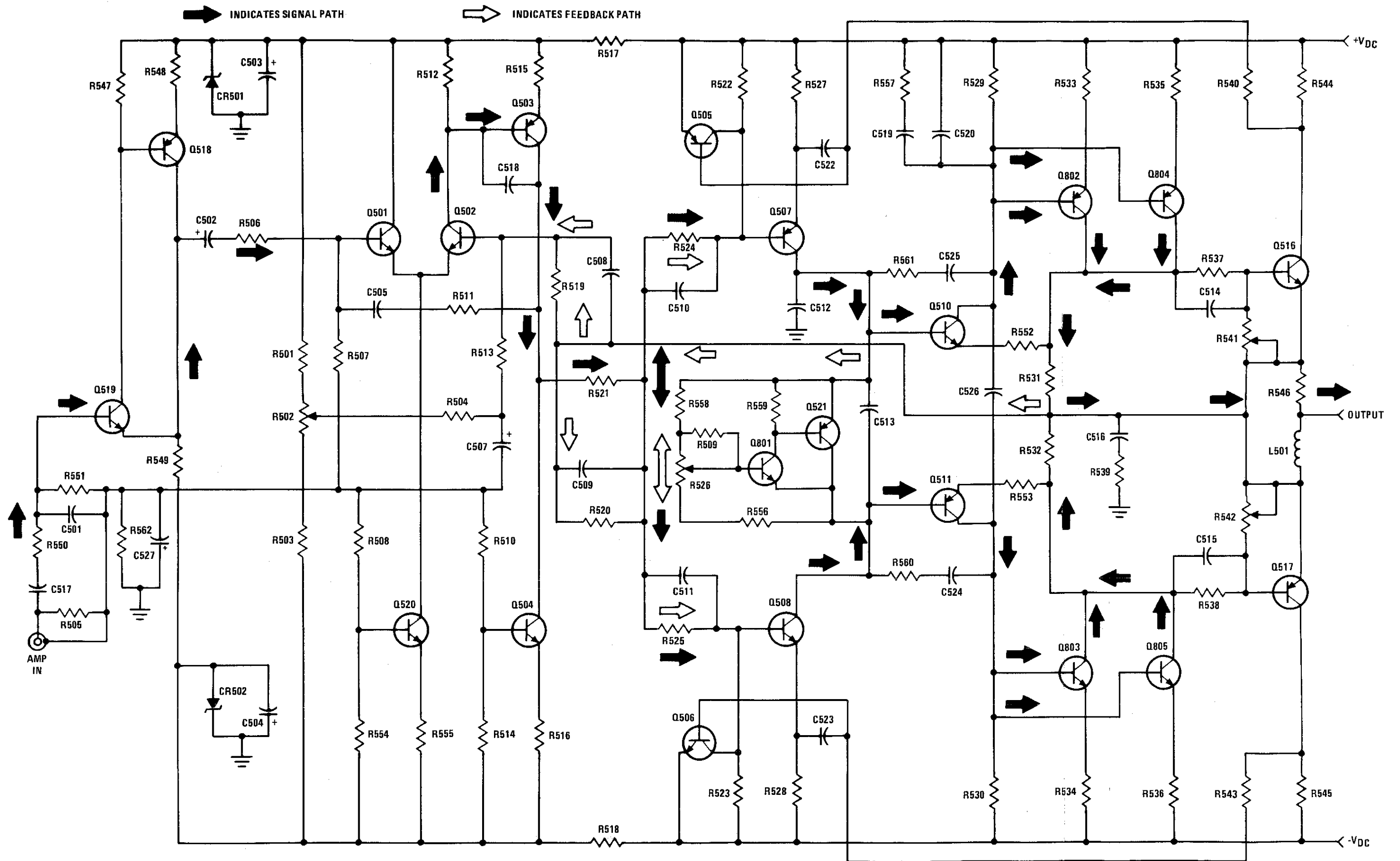

Figure 5. Amplifier Simplified Schematic

# CIRCUIT DESCRIPTION (Continued)

## RELAY BOARD AND POWER SUPPLY

The output of the power amplifier circuit is applied to the wipers of relay K301 of the relay board circuit, Figure 7. The relay energizes after a minimum delay of two seconds after AC power is applied to the unit. The duration of the delay is a factor of the time constant of R706, R707, and C702. This delay at turn-on is to prevent any transient surges from reaching the output terminals. Additionally, resistors R701 and R702 sample the audio output signals. Should a constant DC level greater than +4.5V, or a high amplitude signal below 10Hz be present, Q701 will turn on, shorting the base of Q703 to ground. C702 begins to discharge and K701 de-energizes. Should a constant DC level more negative than -4.5V be present, the voltage drop across R704 bucks the voltage present at the base of Q703 and K701 de-energizes. When the relay is energized, the audio output is applied to the speaker terminals.

The DC power supply voltage for the power amplifier circuit and the metering circuit is  $\pm 58.5V$ . 75VAC is developed across the secondary of T1, which is rectified by the full-wave bridge comprised of CR1 through CR4. The rectified positive and negative voltages are each filtered by a 20,000  $\mu f$  capacitor (C1 and C2). Resistors R1 and R2 are bleeder resistors.

The DC voltage for the relay circuit is +58V. The AC voltage from the transformer secondary is rectified by CR705 and CR706 (contained on the relay board) and filtered by C705.

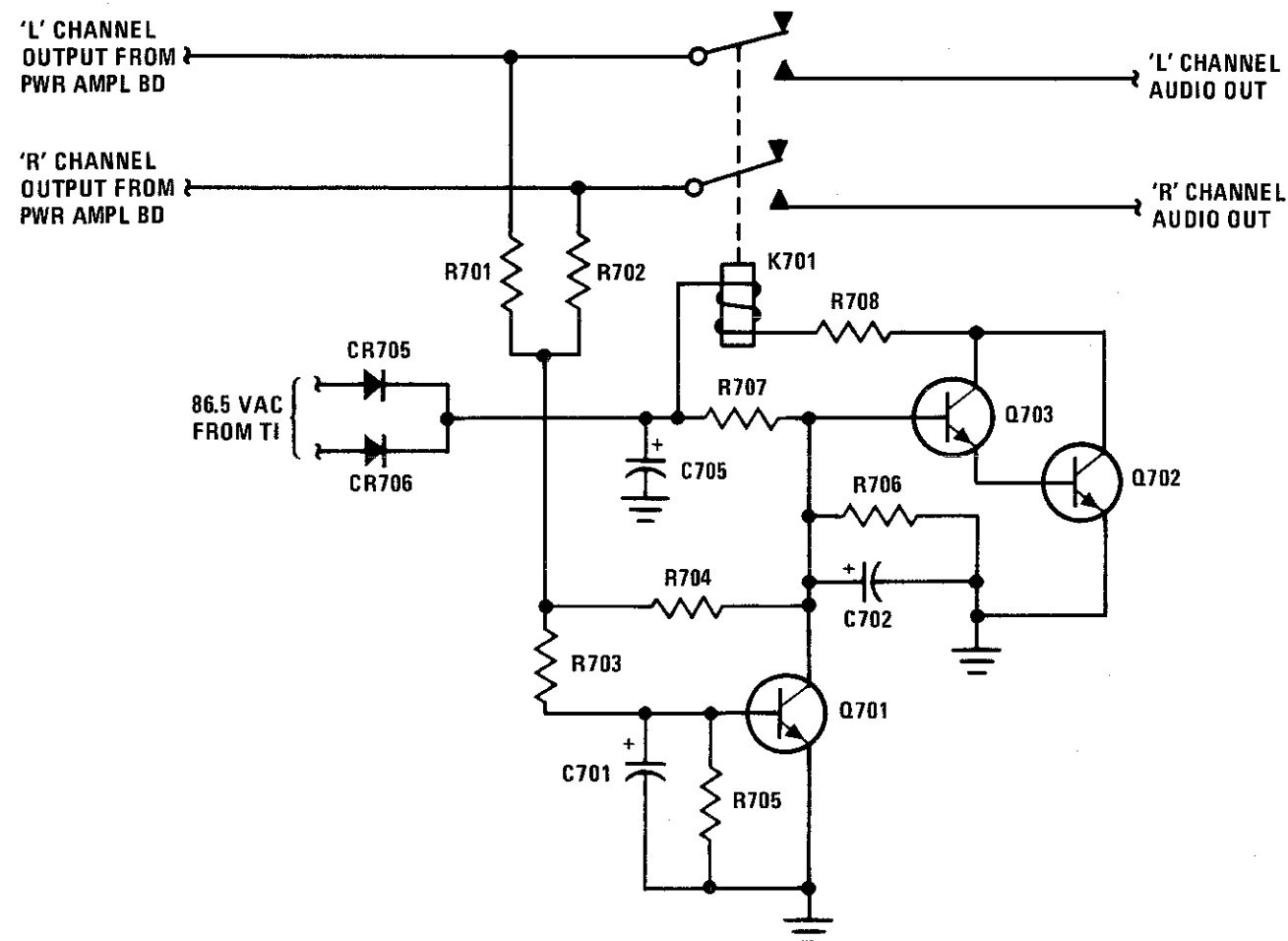

Figure 7. Relay Board Simplified Schematic

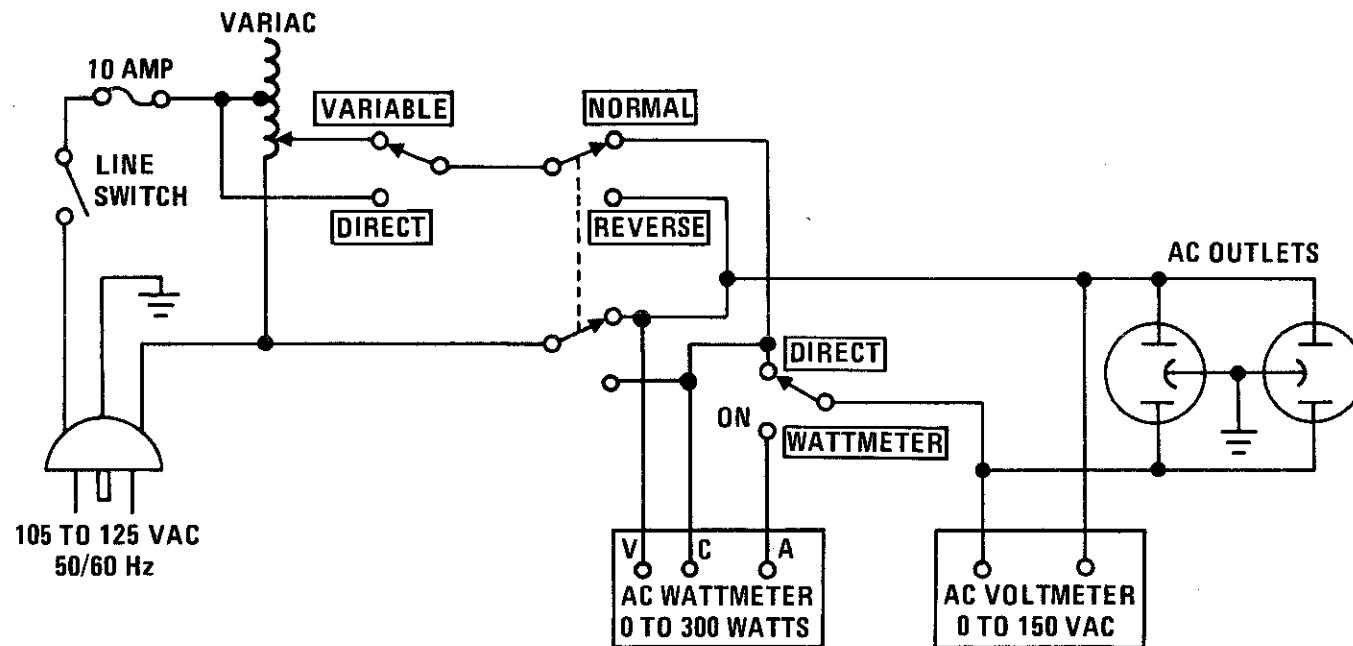

Figure 10. AC Power Control Box Simplified Schematic

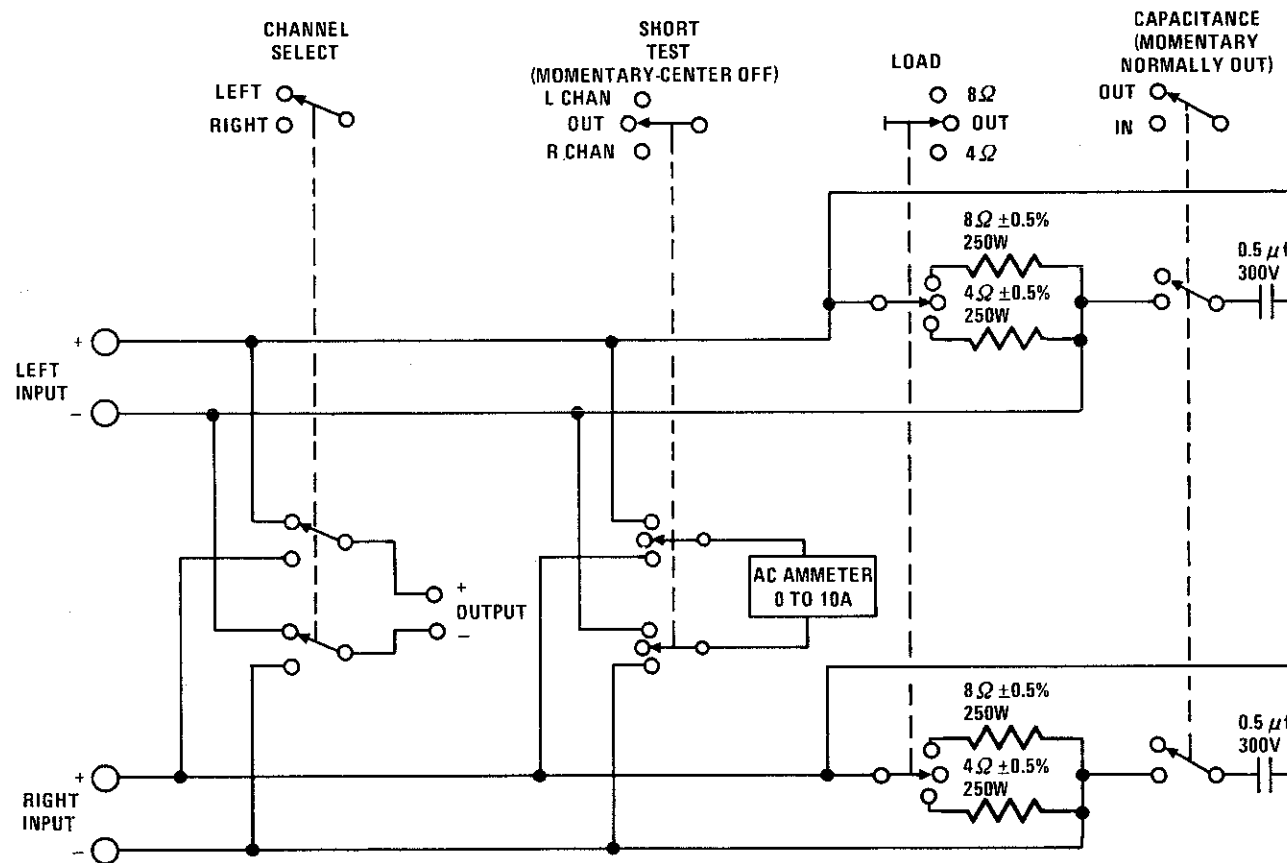

Figure 11. Amplifier Output Load Box Simplified Schematic



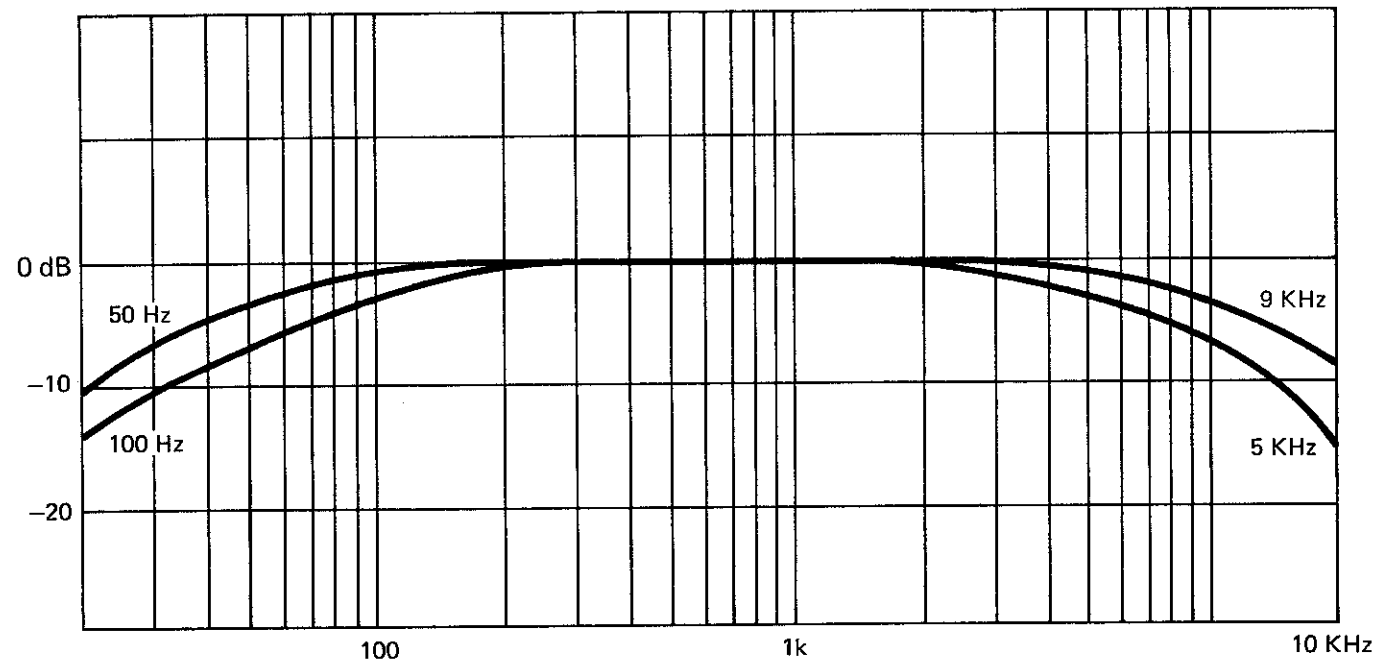

Figure 3. Filter Response Curve.

provides a gain of 20dB. The output of the X10 amplifier is applied to the TONE CONTROL switch and the tone amplifier.

With the TONE CONTROL switch set to IN, the output of the tone amplifier is applied to the GAIN switch on the rear panel, which selects

HIGH or LOW overall preamplifier gain. The output of the GAIN switch is applied to the PREAMP OUT jacks.

With the TONE CONTROL switch set to OUT the output of the X10 amplifier is applied directly to the GAIN switch, bypassing the tone amplifier.

The unity gain tone amplifier, Figure 4, comprises a single-ended differential amplifier (Q304, Q305) and an inverter (Q306). The frequency response of the tone amplifier is adjusted by the BASS and TREBLE controls. The frequency response curves for each 2dB of adjustment are shown in Figure 6.

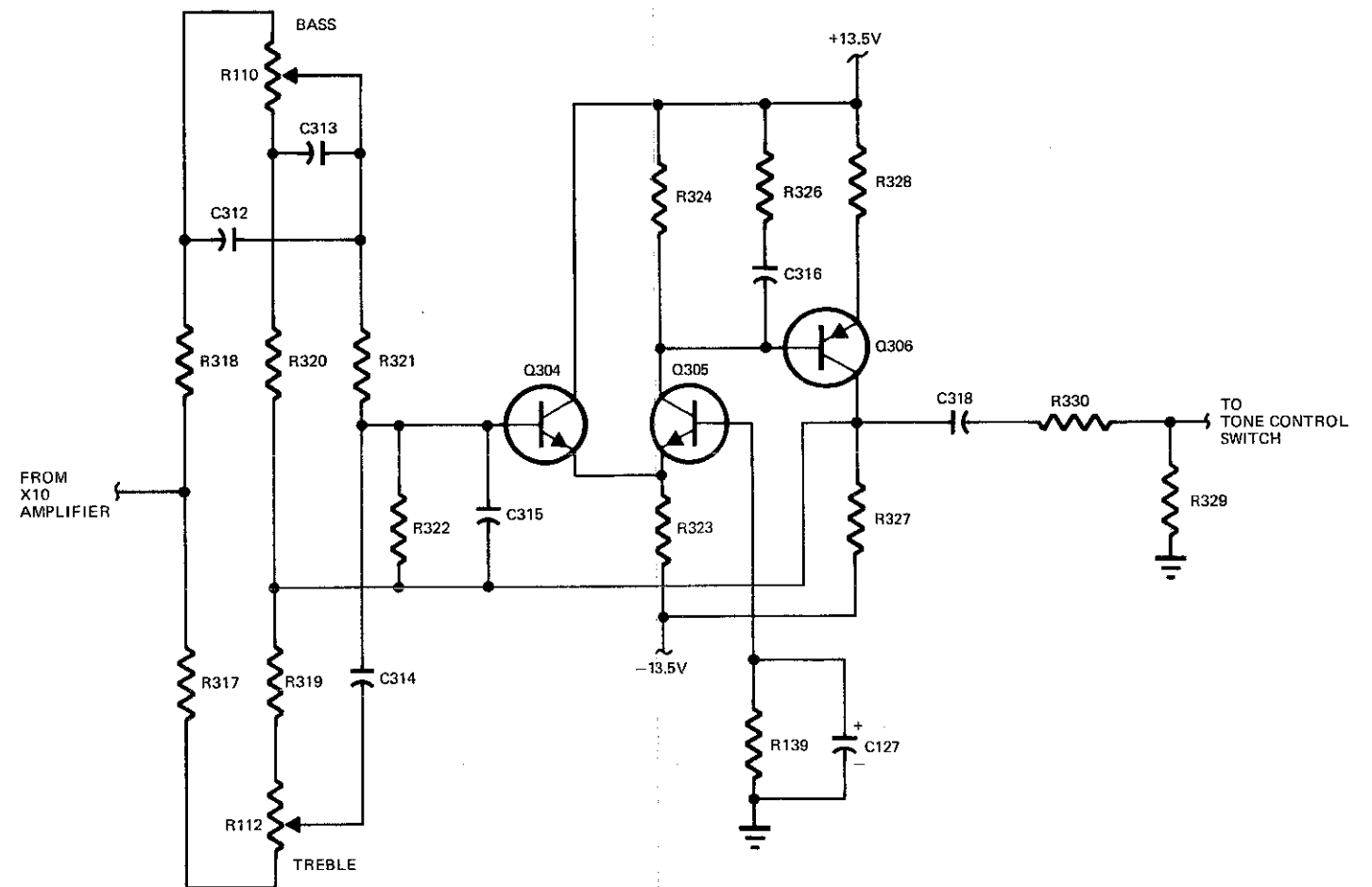

Figure 4. Tone Amplifier Simplified Schematic.

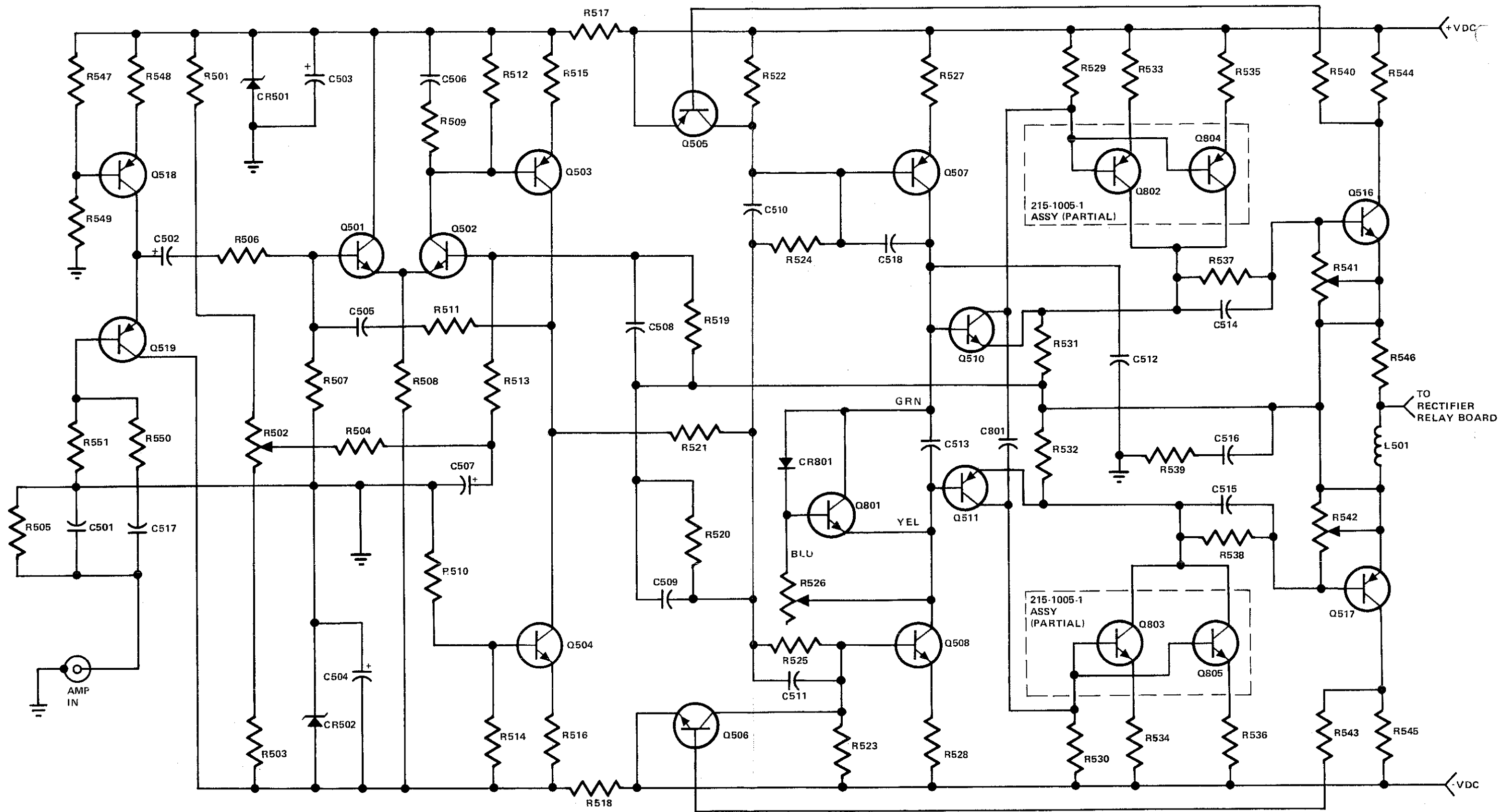

Figure 5. Amplifier Simplified Schematic.

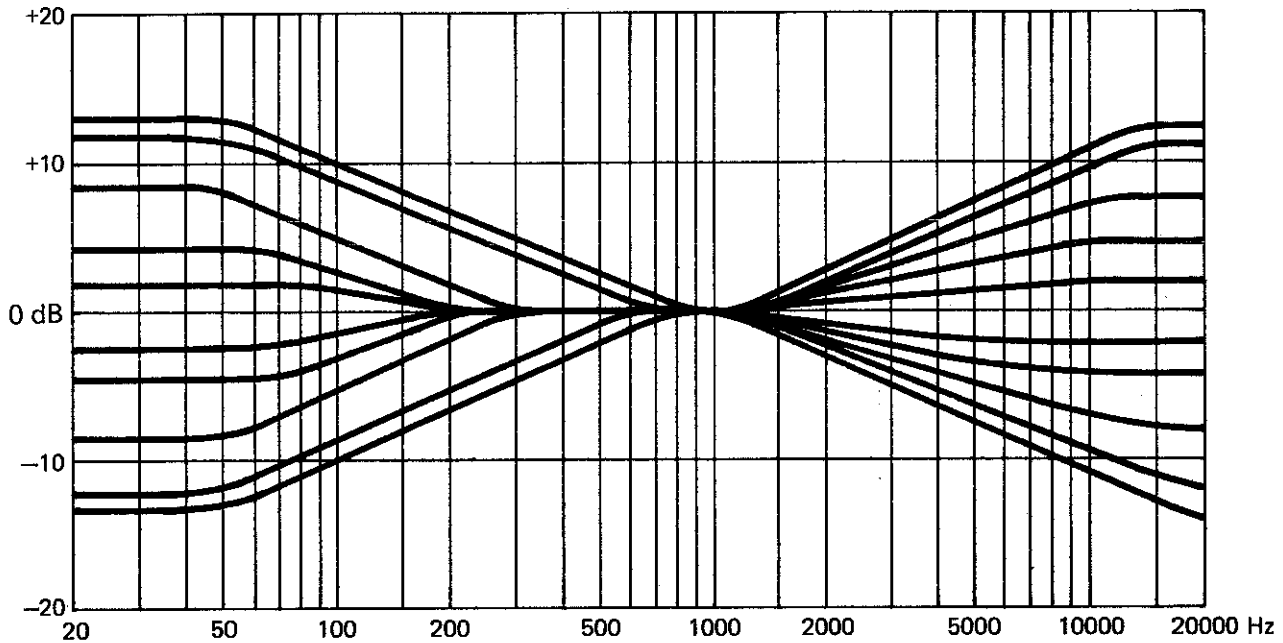

Figure 6. Tone Control Response Curves.

## AMPLIFIER

The preamplifier outputs are connected to the power amplifier inputs by molded RCA pin plug bridging assemblies between the PREAMP OUT and AMP IN jacks on the rear panel. The input stage of the power amplifier, fig. 5, is comprised of an emitter-follower, Q519, and its current source, Q518. The output of this stage is coupled through C502 and R506 to the differential amplifier (Q501, Q502), which drives an inverter (Q503) whose collector current is developed through current source Q504. The inverter is coupled to complementary pre-drivers (Q507, Q508). The output of the pre-drivers is applied to their respective drivers (Q510, Q511) which are coupled to their respective power transistors (Q892, Q804-Q803, Q805).

Output current regulation is accomplished through

a current-sensing network. Excessive current levels are detected by resistors R531 and R532. Voltages developed across these resistors are applied to current sensors Q516 and Q517.

When excessive current levels are detected, Q516 and Q517 develop peak-limiting signals, which are applied to Q505 and Q506. These transistors disable the pre-drivers on excessive output current peaks, thus limiting peak output current to a safe level.

Feedback for the amplifier is developed at the junction of R531 and R532. The feedback is applied across two loops. Feedback applied across R520 and C509 completes the driver-power output loop. Feedback applied across R519 and C508 completes the loop for the entire power amplifier.

# RECTIFIER-RELAY BOARD

The output of the power amplifier is applied to the wipers of relay K701 on the rectifier relay board, Figure 7. Relay K701 energizes after a minimum delay of two seconds after turn on. The length of the delay is a factor of the time constant of R706, R707, and C702. This delay at turn-on is to prevent any transient surges from reaching the output terminals. Additionally, resistors R701 and R702 sample the audio output signals. Should a constant DC level over +4.5 volts or a high amplitude signal below 10Hz be present, Q701 will turn on, shorting the base of Q703 to ground. C702 begins to discharge and K701 de-energizes. If a constant DC level over -4.5 volts is present, the voltage drop across R704 bucks the voltage present at the base of Q703 and K701 de-energizes. The output from K701 is applied to the SPEAKER select switch. Additionally, it is applied across resistor loads to the CENTER CHANNEL VOLUME CONTROL and to the HEADPHONE jack.

76 volts AC is applied to diodes CR701 through CR740 which develop the +52 and -52 volts for the power amplifier board. CR705 and CR706 develop the positive voltage to energize K701.

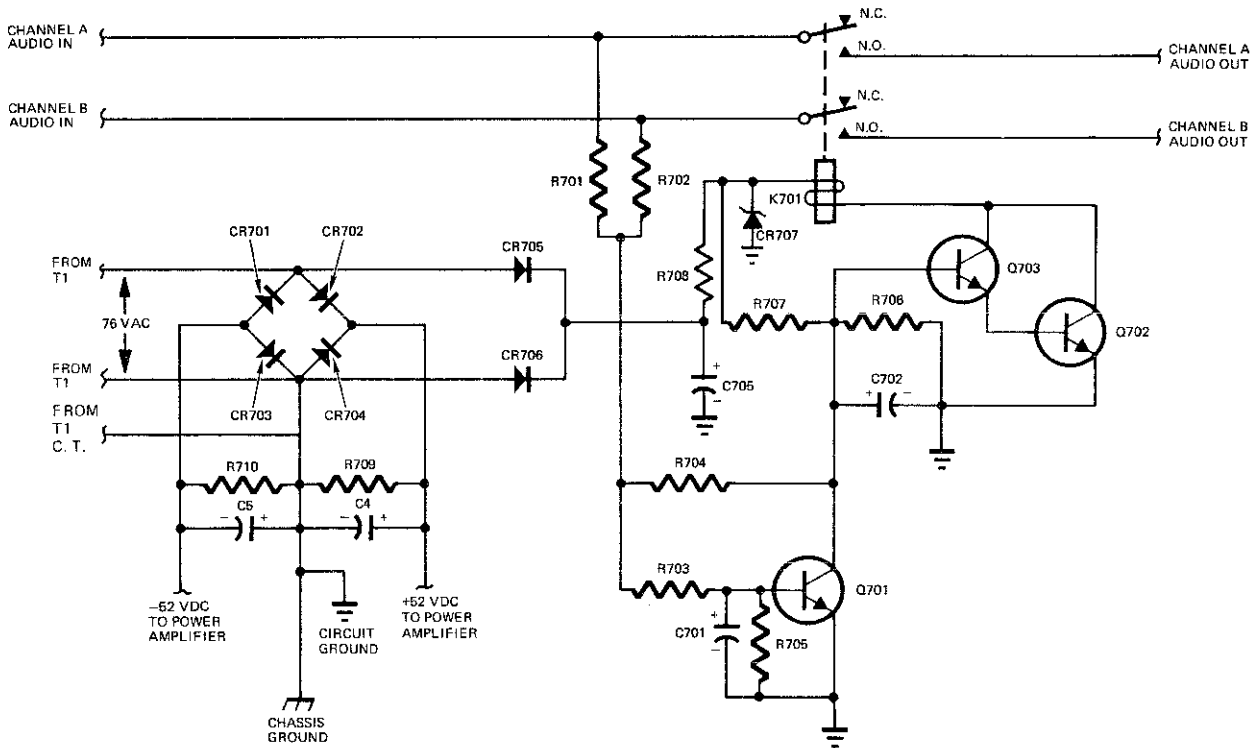
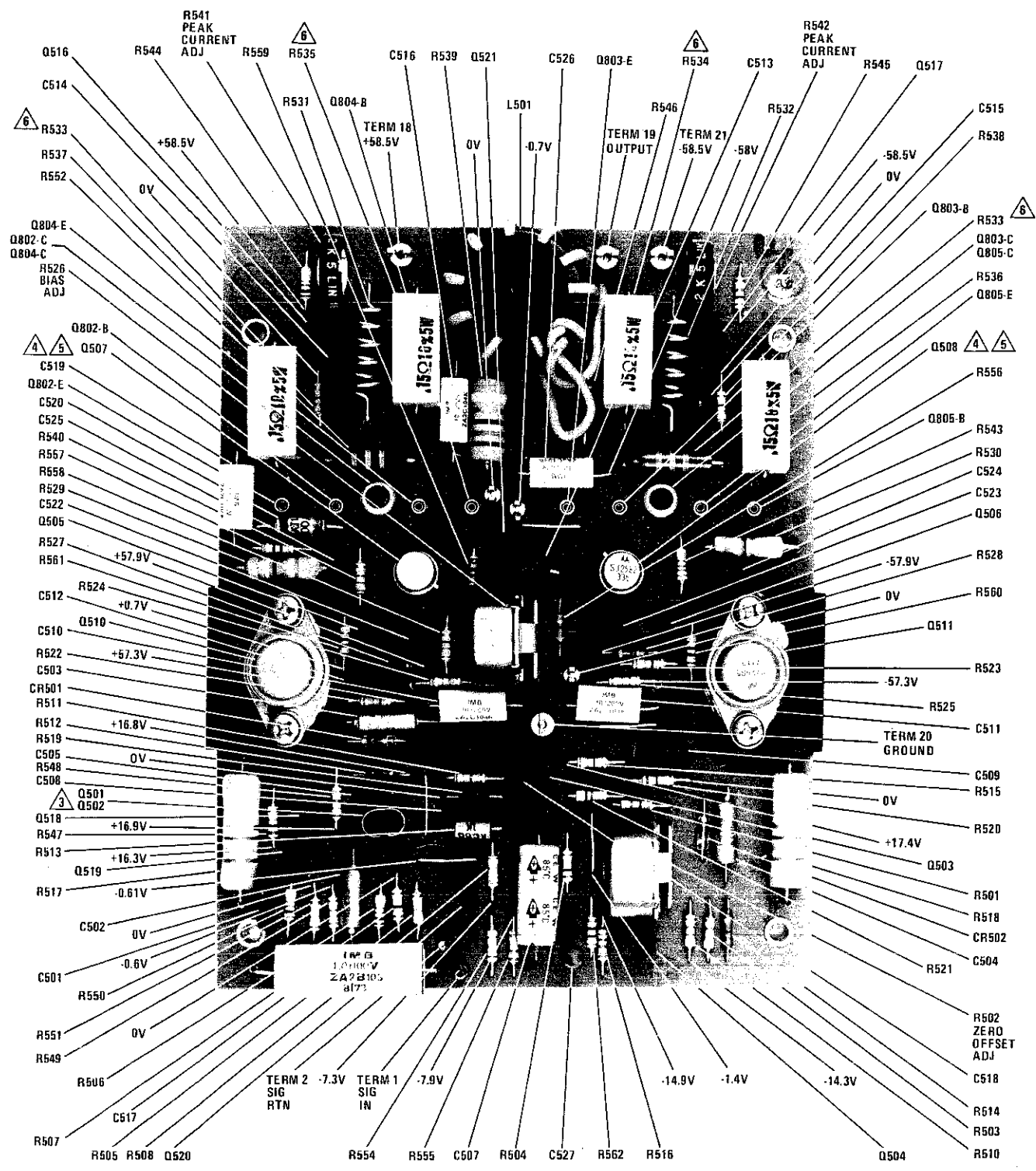
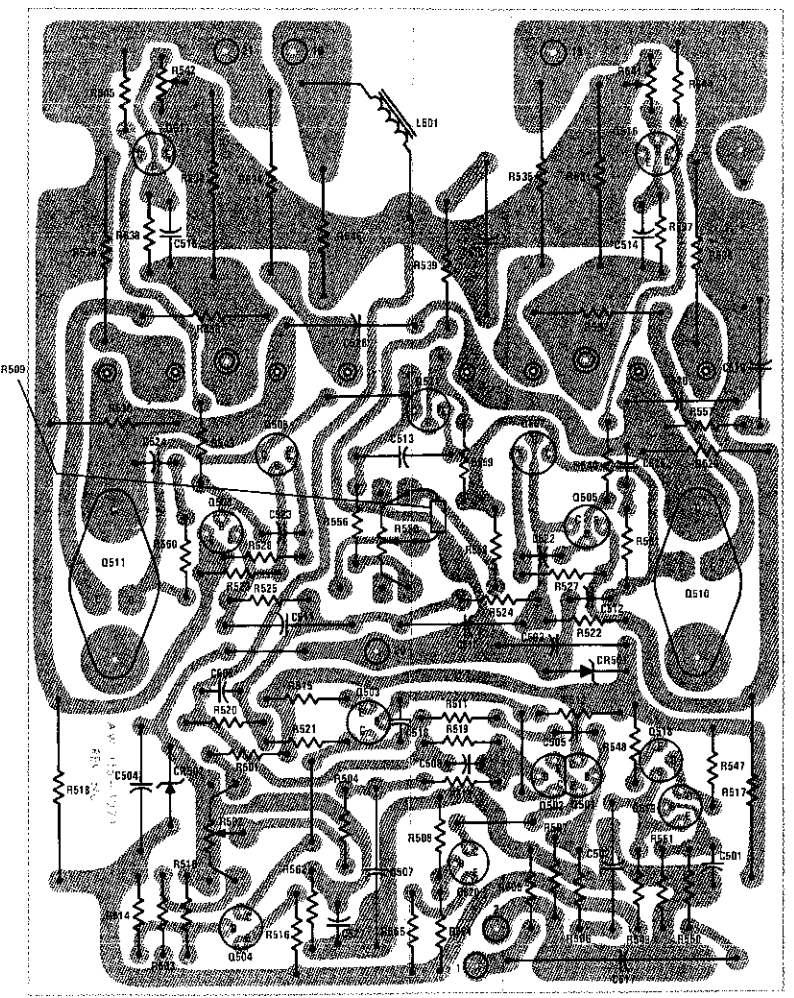

Figure 7. Rectifier/Relay Board Simplified Schematic.



- NOTES:
1. VOLTAGES ARE DC VOLTS TO GROUND, MEASURED ON A TYPICAL UNIT.
  2. CONFIGURATION SHOWN IS APPLICABLE TO CIRCUIT BOARDS FABRICATED FROM A/W 115-1071, REV N/C.
- ⚠ TRANSISTOR PAIR Q501-Q502 ARE TO BE EQUALLY SPACED OFF THE BOARD WITH THEIR ENTIRE FLAT SURFACES IN INTIMATE CONTACT. P/N 562-1005-000 THERMAL RETAINER TO BE INSTALLED ON THE PAIR.
  - ⚠ P/N 562-1000-000 HEAT DISSIPATOR TO BE INSTALLED ON Q507 AND Q508.
  - ⚠ P/N 372-1000-000 INSULATOR TO BE INSTALLED UNDER Q507 AND Q508.
  - ⚠ RESISTORS R533, R534, R535 AND R536 TO BE INSTALLED 1/8" MINIMUM OFF BOARD.

COMPONENT SIDE



CIRCUIT SIDE

Figure 17. Power Amplifier Board – A5/A6 Component Assembly Diagram



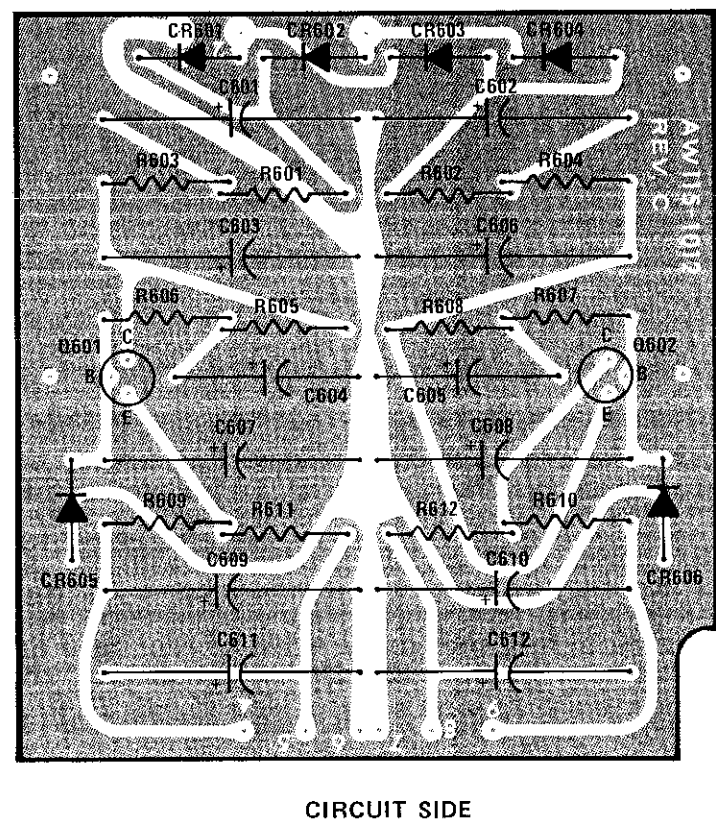
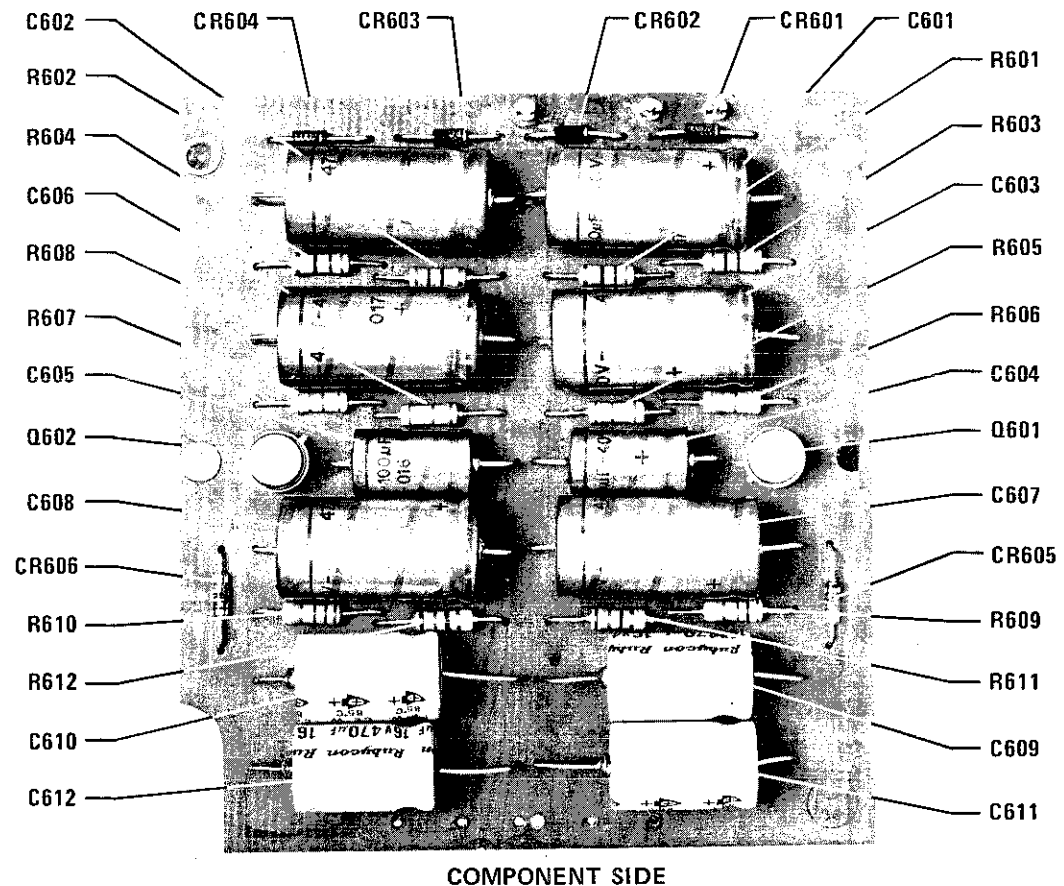

Figure 18. Power Supply Board – A7 Component Assembly Diagram

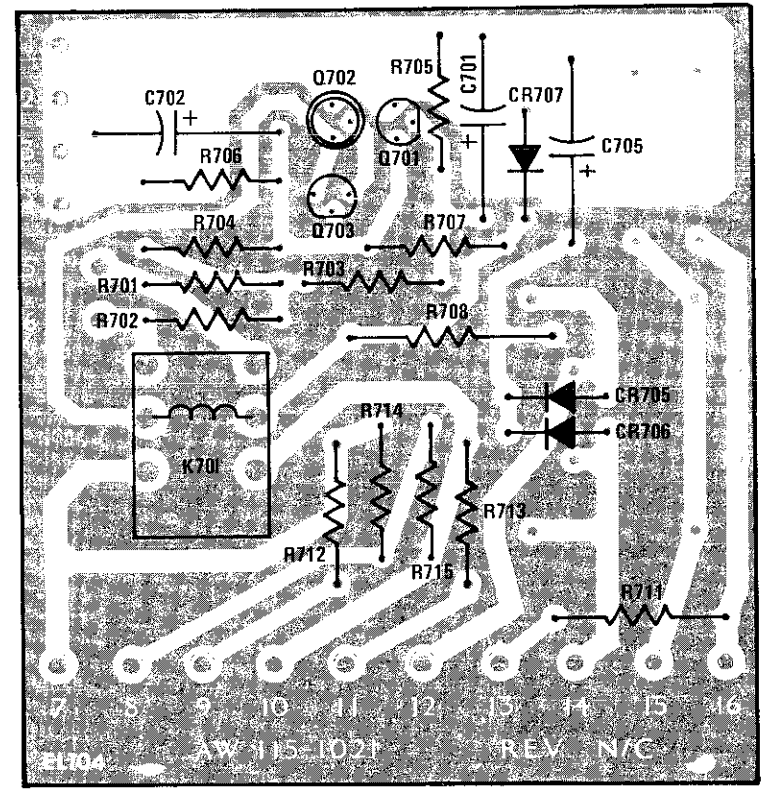
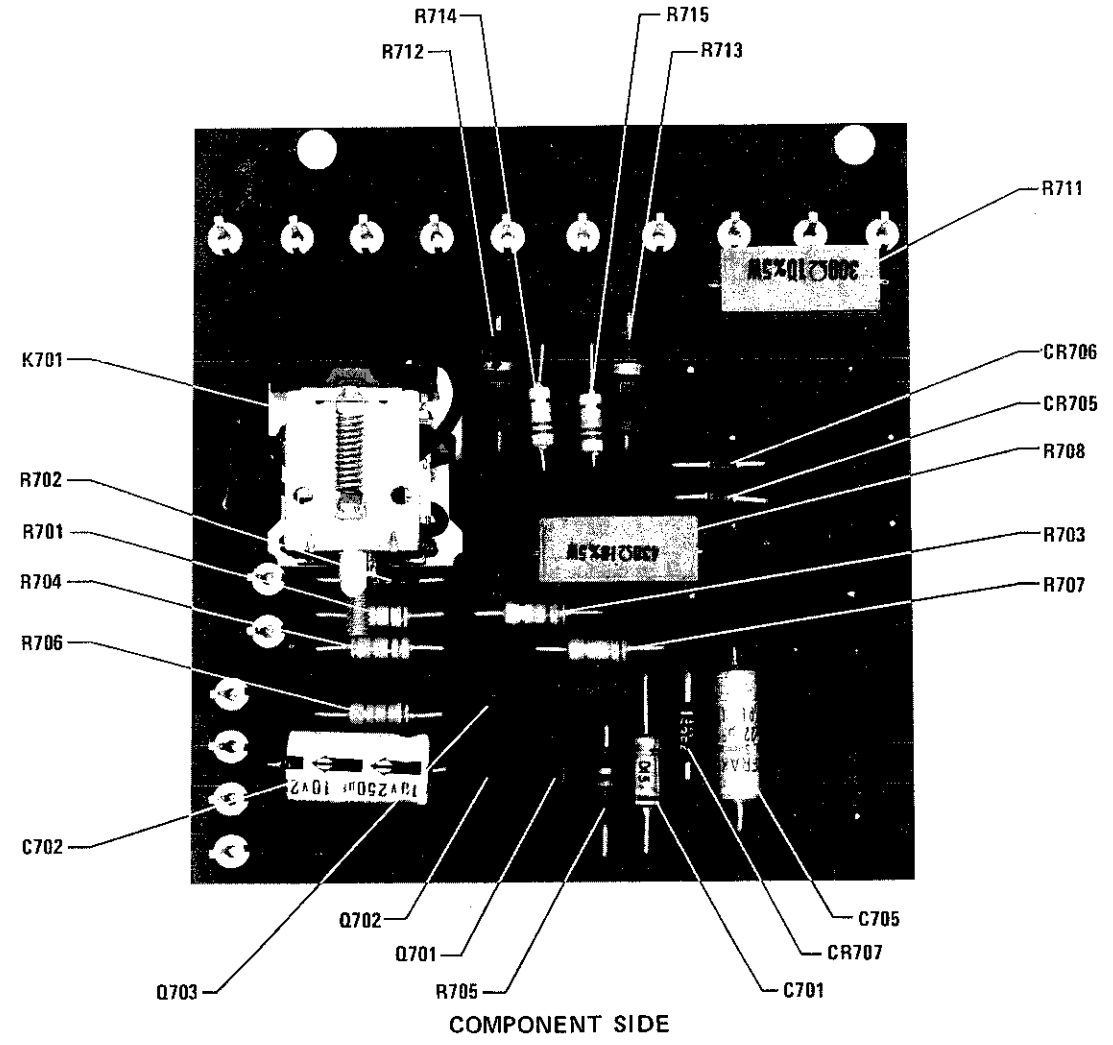

Figure 19. Relay Board – A8 Component Assembly Diagram

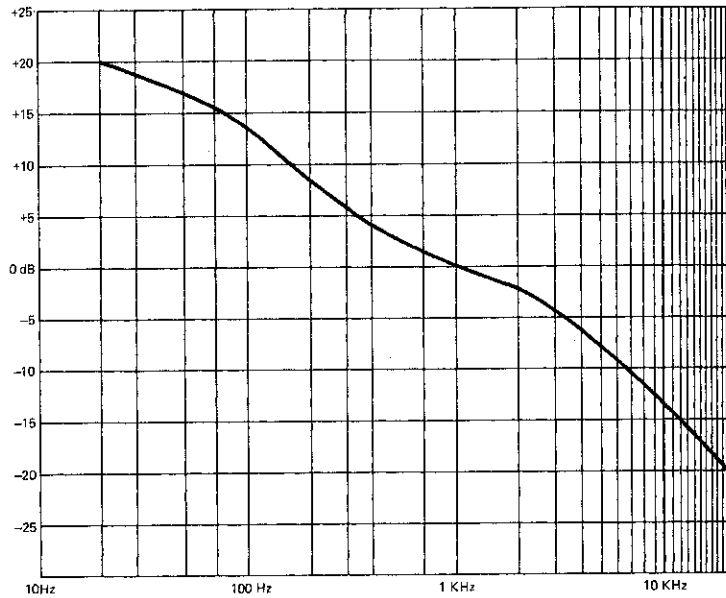

Figure 8. RIAA Equalization Curve

RIAA NAB DISK REPRODUCING STD.

20 KHz	-20 dB
15 KHz	-17.17 dB
14 KHz	-16.64 dB
13 KHz	-15.95 dB
12 KHz	-15.28 dB
11 KHz	-14.55 dB
10 KHz	-13.75 dB
9 KHz	-12.88 dB
8 KHz	-11.91 dB
7 KHz	-10.85 dB
6 KHz	-9.62 dB
5 KHz	-8.23 dB
4 KHz	-6.64 dB
3 KHz	-4.76 dB
2 KHz	-2.61 dB
1000	0
700	+ 1.23 dB
400	+ 3.81 dB
300	+ 5.53 dB
200	+ 8.22 dB
100	+13.11 dB
70	+15.31 dB
50	+16.96 dB
30	+18.61 dB
20 Hz	+ 20 dB

## POWER SUPPLY BOARD

The power supply board, Figure 8, supplies nominal +13.5 and -13.5 volts to the low-level amplifier and pre-amplifier/tone amplifier section

of the pre-amplifier. Thirty-seven volts is applied to rectifiers CR601, 602, 603, and 604. Positive and negative regulation of the diode bridge output is accomplished by Q601 and Q602 respectively. The voltage reference for these two transistors is supplied by Zener diodes CR605 and CR606.

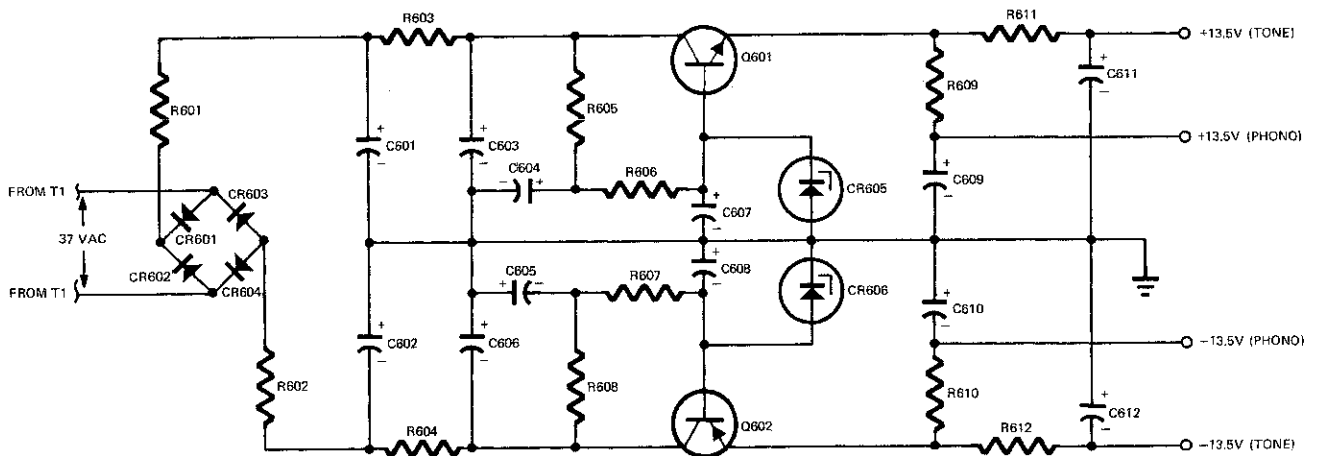
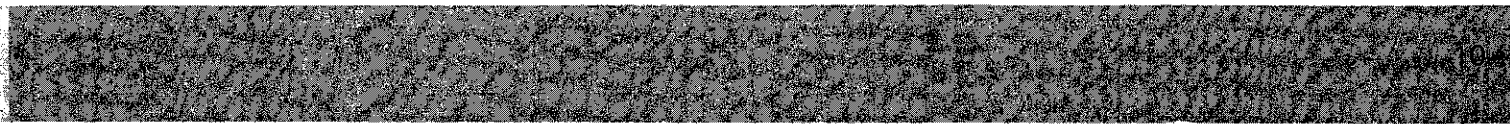

Figure 9. Power Supply Simplified Schematic





# TECHNICAL SPECIFICATIONS

Power Output (each channel, both channels driven, at rated distortion, 20Hz to 20KHz)

Load	RMS
4 ohms	125W
8 ohms	100W
16 ohms	50W

Total Harmonic Distortion ..... at or below rated power,  
(including pre-amplifier) ..... 20HZ to 20 KHz.  
less than 0.15%

Intermodulation Distortion ..... at or below rated power,  
(including pre-amplifier) ..... SMPTE, any combination of two frequencies,  
20Hz to 20KHz: less than 0.15%

Frequency Response ..... +0 -3dB 6 Hz to 80 KHz,  
..... ±.25dB 20Hz to 20KHz

Input Sensitivity and Impedance ..... Phono 1.35mV, 47K ohms  
High Level ..... 135 mV, 100K ohms

Output Level and Impedance (volts RMS)  
Tape Recorder ..... 3V, 1000 ohms  
Headphones ..... 3V, 8 ohms or greater  
Center Channel ..... 3V, 1000 ohms  
Tone Controls (Switch Defeatable) ..... Treble ±10dB at 10KHz  
..... Bass ± 10dB at 100 Hz

Filters:  
High Filters ..... .5KHz and 9KHz  
Low Filters ..... 50Hz and 100Hz

GENERAL

Total Noise ..... Phono (input loaded & shielded)  
..... 2μV equiv. input

Power Requirements ..... 120V AC, 420W, 50/60 Hz

Dimensions ..... 15-3/8" w. x 5-3/4" h.  
..... x 14" deep

Unit Weight ..... 31 pounds  
Shipping Weight ..... 37 pounds

220-Volt AC Conversion  
Split primary windings permit easy conversion  
from 120-Volt to 220-Volt operation.



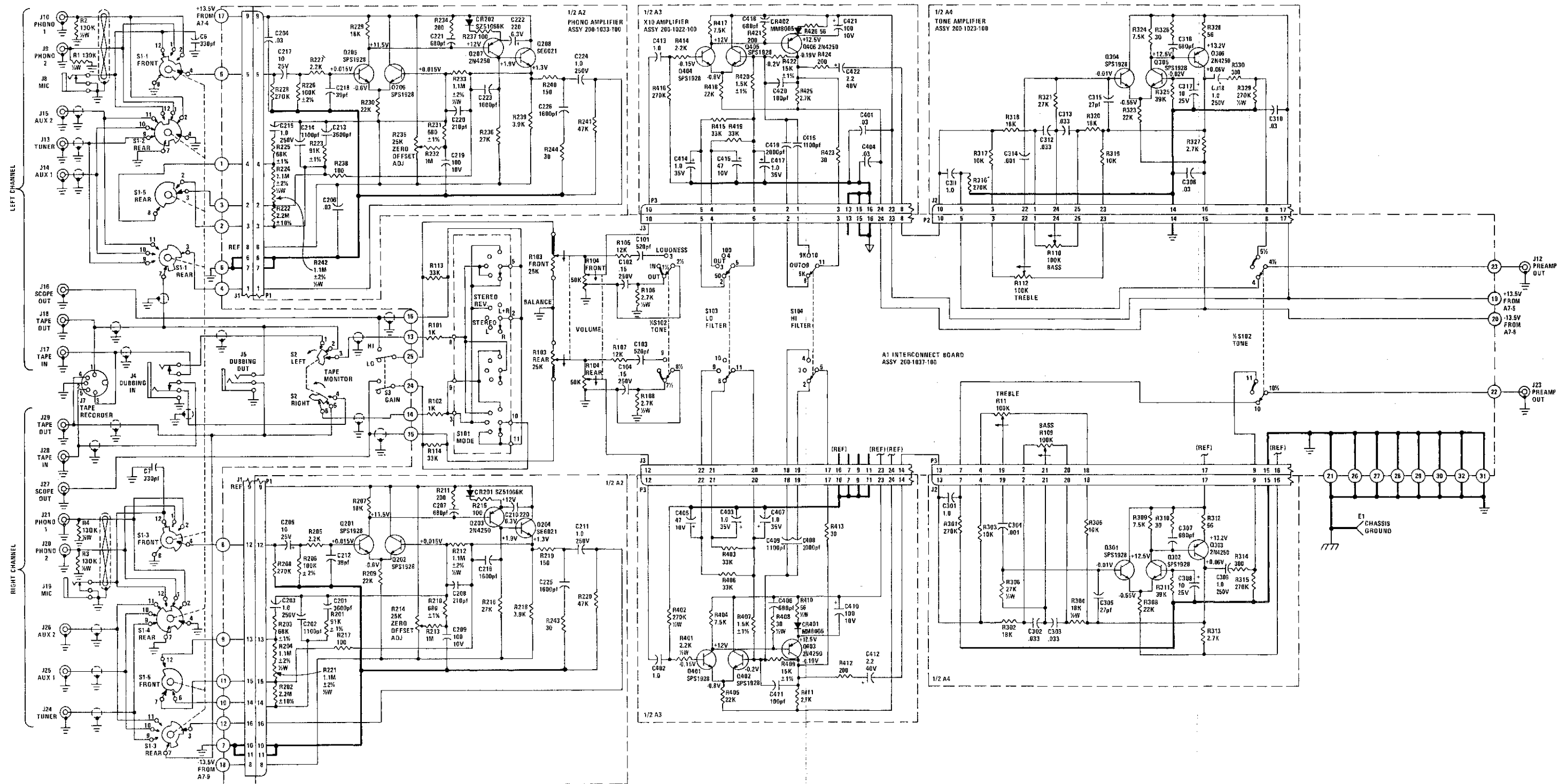

Figure 20. Model 1200B Schematic, A

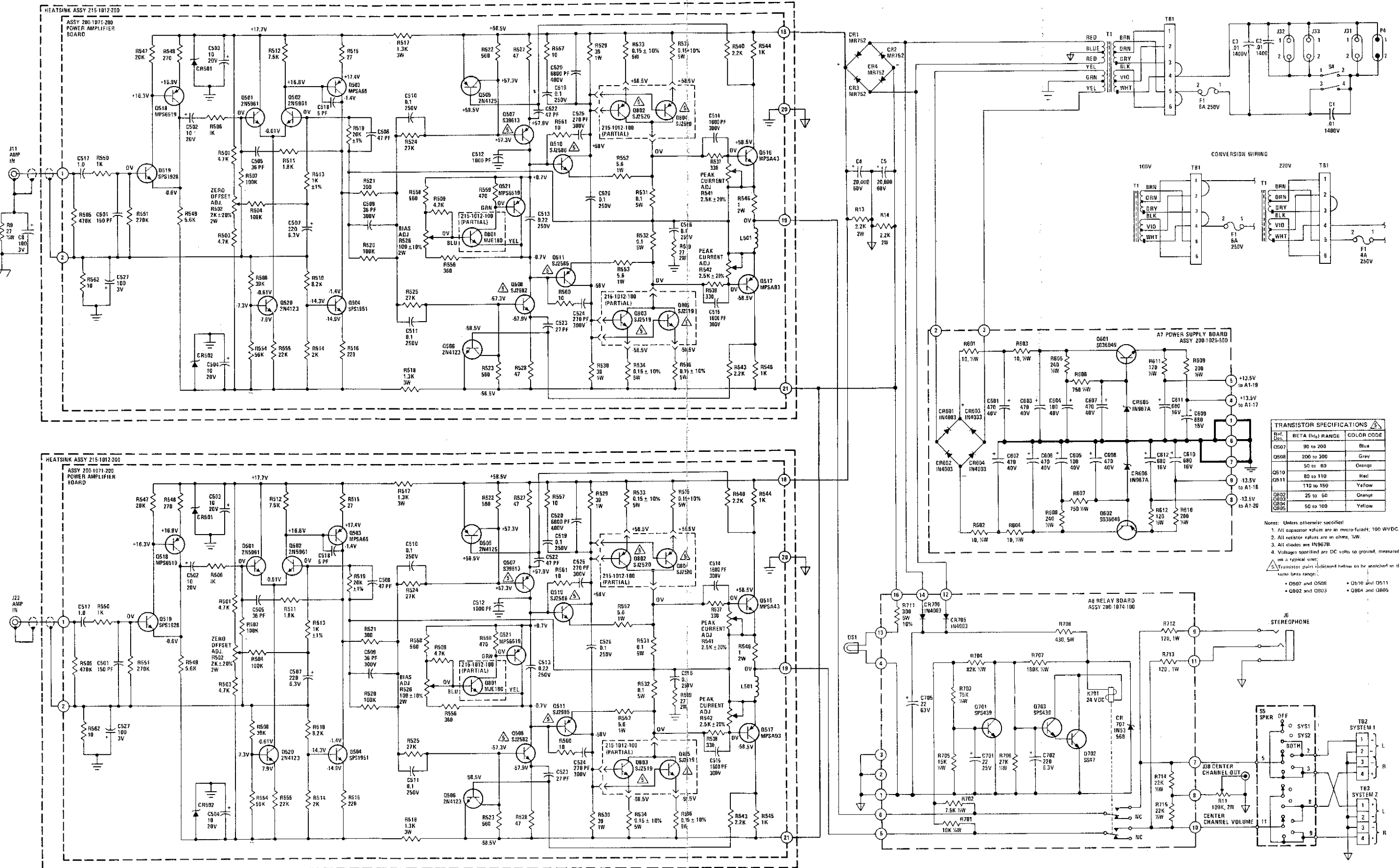

Figure 21. Model 1200B Schematic, B

## TEST EQUIPMENT REQUIRED FOR SERVICING

Table 1 lists the test equipment required for servicing the Model 1200 Stereo Console Amplifier. The wattmeter, ac voltmeter, and variac may be assembled as a test fixture as shown schematically in Figure 9, and the load resistors and ac ammeter may be assembled into a second test fixture as shown in Figure 10.

Item	Manufacturer and Model No. (or equivalent)	Use
Distortion Analyzer	Hewlett Packard, Model 331A or 333A	Measures distortion and voltage of amplifier output.
Audio Oscillator	Weston Model CVO-100P (NOTE: Less than 0.02 percent residual distortion is required.)	Sinewave and squarewave signal source.
Oscilloscope	Tektronix, Model 503; Data, Model 555	Waveform analysis and troubleshooting
VTVM	RCA Senior Volt-Ohmyst, Model WV-98C	Voltage and resistance measurements.
AC Wattmeter	Simpson, Model 390	Monitors primary power consumption of amplifier.
AC Ammeter (0 to 10 amps)	Commercial Grade	Monitors amplifier output under short circuit condition.
Line Voltmeter (0 to 150 vac)	Commercial Grade	Monitors potential of primary power to amplifier.
Variable Autotransformer (0 to 140 vac, 10 amps)	Powerstat, Model 116B	Adjusts level of primary power to amplifier.
Shorting Plug	Use phono plug with 600 ohms across center pin and shell.	Shorts amplifier input to eliminate noise pickup.
Power Supply Bleeder Resistor (10 ohms at 1 W)	Commercial Grade	Discharges power supply filter capacitors prior to disassembly or resistance measurements.
Output Load Resistor (8 $\Omega$ $\pm$ 0.5%, 250 W)	Commercial Grade	Provides 8-ohm load for amplifier output termination.
Output Load Resistor (4 $\Omega$ $\pm$ 0.5%, 250 W)	Commercial Grade	Provides 4-ohm load for amplifier output termination.
Output Load Capacitor (0.5 mfd)	Mylar	Provides capacitive load for instability checks.
AC Power Control Box	Optional Item. Fabricate in accordance with Figure 3.	Monitors and controls primary power for amplifier.
Amplifier Output Load Box	Optional Item. Fabricate in accordance with Figure 4.	Provides various amplifier loads and can monitor shorted output.

## 220 and 100 VOLT AC CONVERSION

### 220-VOLT AC CONVERSION

To convert the Model 1200 to 220-volt operation, perform the following steps:

1. Remove the top cover.
2. Orient the Model 1200 so that the rear panel is facing toward the viewer.
3. Locate TB1, the strip located on the power transformer half shell facing the rear panel, which terminates the power transformer primary wires.
4. Unsolder the black and white power lead-in wires and all jumpers from TB1.
5. Solder a jumper to TB1 connecting the grey and violet transformer wires.
6. Solder the black and white power lead-in wires to the brown and white transformer wires, respectively, on TB1.
7. Re-attach the top cover.
8. Replace the 6-amp, 250V fuse in the unit with the 4 amp, 250V fuse, Part # 451-1003, supplied with the 220-volt conversion kit, Part # 105-1005-1.

### 100-VOLT AC CONVERSION

To convert the Model 1200 to 100-volt operation, follow the procedure outlined for 220-volt conversion, except for items 5, 6, and 8. Item 8 is eliminated. These items will read:

5. Solder two jumpers to TB1, one connecting the orange and violet transformer wires, and one connecting the grey and white transformer wires.
6. Solder the black and white power lead-in wires to the orange and white transformer wires, respectively, on TB1.

The Model 1200 is now ready for 100-volt operation.

## PERFORMANCE VERIFICATION TEST PROCEDURE

### A. Test equipment.

Refer to Table I for required test equipment.

### B. Preliminary Procedures.

1. Make the test setup shown in Figure 11 with the instrument controls set in the following positions:
 

Line Switch	off
Variable — line switch	variable
Watt Meter Switch	on
Variac	0 (fully CCW)
Load	4 ohms (0.5 mfd — Off)
Audio Generator	Frequency 2 KHz
Output	5V range
Gain Minimum	
AC Volt Meter	30V range
2. Make sure that connections between the resistive load and the system terminals of the Model 1200 have negligible resistance compared with the resistance of the load itself. Appreciable resistance in wiring adds to the total load, resulting in inaccurate measurement of output power.
3. Connect amplifier output to load and connect AC cord to line power. Connect a shorting plug (600 ohms) to the Phono 1 input jack of the model 1200.
4. Remove the top cover.

### C. Bias Adjustment Tests

1. Remove the channel A and channel B power amplifier heat sinks from the chassis, leaving all wires connected.
2. With the component side of the amplifier board face up, rotate bias potentiometer R526 on each amplifier board fully CCW.
3. Turn the line switch on and slowly advance the variac while observing the voltmeter and wattmeter. When the line voltage reaches approximately 105 volts, the speaker relay should energize. The wattmeter should indicate less than 40 W. If the wattmeter indicates either 0 or greater than 40-watts, a defect exists. Turn off the variac and refer to the trouble analysis section of this manual.
4. Adjust left channel bias potentiometer R526 until the wattmeter indicates 10 watts above the initial reading.

- Adjust right channel bias potentiometer R526 until the wattmeter indicates 10 watts above the reading with the left channel properly biased.

#### D. Balance Tests

- With a VTVM connected to channel A SYSTEM 1 output terminals, set the VTVM in the DC mode. Select the greatest gain position (0.5V full scale or lower).
- Turn the amplifier on and set the SPEAKER switch to SYSTEM 1. Adjust channel A amplifier board potentiometer R504 for an indication of  $0V \pm 50mV$  as indicated on the VTVM.
- Connect the VTVM to channel B SYSTEM 1 output terminals. Adjust channel B amplifier board potentiometer R504 for an indication of  $0V \pm 50mV$  as indicated on the VTVM.

#### E. Total Hum and Noise Test

- With 600 ohms shorting plugs connected to the PHONO 1 input jacks and a 4-ohm resistive load connected across the SYSTEM 1 output terminals, connect a distortion analyzer across the load.

NOTE: In this test and tests that follow, if distortion analyzer used does not contain a built-in voltmeter, a VTVM may be substituted.

- Set the distortion analyzer controls for voltage measurements and apply power to the amplifier. Set the volume control fully CCW. Set the SELECTOR switch to PHONO 1.
- If the distortion analyzer indicates more than two millivolts, refer to trouble analysis section of this manual.
- Set the volume control fully CW. If the distortion analyzer indicates more than 36 millivolts refer to the trouble analysis section of this manual.

#### F. Maximum Power Output

- Connect the audio oscillator to the AUX 1 input. Set audio oscillator frequency to 2KHz. Set SELECTOR switch to AUX 1.
- With the distortion analyzer connected across the output load (4 ohms), set the analyzer on the 30V AC scale.
- Turn potentiometers R541 and R542 fully CCW.
- Turn the analyzer on and increase the audio oscillator output until the analyzer indicates 24.0 volts AC.

- Adjust potentiometer R541 CW until the positive peak of the wave form as observed on the oscilloscope just begins to clip.
- Adjust potentiometer R542 CW until the negative peak just begins to clip.
- Change output load to 8 ohms. Set analyzer sequentially to 20Hz, 2KHz, and 20KHz. Output voltage should be greater than 28.3 volts AC.
- Reduce audio oscillator output to minimum.

#### G. Relay Operation

- Set line switch to off. Wait approximately two minutes.
- Using a stop watch or the sweep second hand on a watch, time the relay delay from the time that the line switch is turned on.
- Turn the line switch on, time delay should be between two and ten seconds.
- Set audio oscillator for 10Hz. Slowly increase output of oscillator until relay de-energizes. Distortion analyzer should indicate between 15 and 22 volts just prior to relay cut off.

#### H. Harmonic Distortion Test

- Set the frequency of the audio oscillator and the distortion analyzer to 20KHz.
- Set the controls of the analyzer for voltage measurement on the 30-volt scale.
- Adjust the audio oscillator output level until the analyzer meter indicates 28.3 volts.
- Switch the distortion analyzer to SET LEVEL-MANUAL mode, and adjust SENSITIVITY for full scale reading on 0-1 scale.
- Measure the total harmonic distortion with the analyzer and verify it is less than 0.15 percent.

NOTE: Any parasitic oscillation in the amplifier will be displayed on the oscilloscope when capacitance is switched into the load.

- Switch 0.5 MFD across the load (Figure 10) and verify distortion is no greater than 0.3 percent. Switch 0.5 MFD out of the load.
- Switch the distortion analyzer back to SET LEVEL MANUAL. (Do not adjust SENSITIVITY of analyzer.)

8. Change the frequency of the audio oscillator and distortion analyzer to 2KHz. Adjust audio oscillator output as necessary to have a full scale reading on the 0-1 scale on the analyzer.
9. Measure the distortion, verifying it is no greater than 0.15 percent.
10. Repeat steps 8 and 9, changing frequency to 20 Hz. Distortion should be no more than 0.15 percent.
11. Switch 0.5 MFD across the load and verify distortion is no more than 0.3 percent.
12. Check for parasitic oscillations; there should be none.

#### I. Short Circuit Test

1. Switch back to a 4-ohm load and set the audio oscillator to 400Hz. Adjust output level of oscillator just below clipping of the output wave as displayed on the oscilloscope.

**CAUTION:** Do not perform short circuit test if amplifier shows any sign of parasitic oscillation.

2. Press the momentary switch (Figure 10) to a short circuit condition for no longer than three seconds. Verify the ac ammeter indicates no more than 9.5 amperes.

#### J. FREQUENCY RESPONSE

1. Set LOAD to 8 ohms.
2. Set audio oscillator to 20Hz.
3. Adjust oscillator output for an indication of 28.3 volts AC on distortion analyzer.
4. Sweep frequency up to 20KHz.
5. Output should remain within 27.4 volts to 29.2 volts AC.
6. Connect audio oscillator to PHONO 1 input jacks, set SELECTOR switch to Phono 1.

7. Set audio oscillator to 1KHz  $\pm$ 10Hz.
8. Adjust audio oscillator output for 1 millivolt. Distortion analyzer should indicate between .81 and 1.19 volts.
9. Adjust audio oscillator output for an indication of 0dB on analyzer.
10. Set audio oscillator to 20Hz.
11. Sweep frequency up to 20KHz.
12. Output should follow curve shown in figure 12 ( $\pm$ 2dB) as indicated on distortion analyzer.

#### PHONO PREAMPLIFIER DISTORTION TEST

1. Turn VOLUME control fully CCW (off). Connect audio oscillator to CHA Phono 1 input jacks, and set selector switch to PHONO 1. Connect distortion analyzer to CHANNEL A TAPE OUT jacks.
2. Set audio oscillator to 20Hz, 3mv out.
3. Switch the distortion analyzer to the 3 volt scale, and adjust the oscillator output for an output of 3.0 volts at the TAPE OUT jacks.
4. Switch the distortion analyzer to the SET LEVEL MANUAL mode, and adjust SENSITIVITY for a full-scale reading on the 0-1 scale. Set frequency vernier to 20Hz.
5. Measure the total harmonic distortion with the analyzer. If the distortion measures more than 0.1% slowly adjust dc balance potentiometer R235 for minimum distortion.
6. Connect oscillator and distortion analyzer to CHANNEL B PHONO 1 and TAPE OUT jacks, respectively.
7. Repeat steps 3, 4, and 5. Use d-c balance potentiometer R214 for channel B minimum distortion.

#### K. FUNCTIONAL TESTS

1. Perform functional tests on MODE, SELECTOR, HIGH and LOW filter, SPEAKER, TONE CONTROL, and TAPE MONITOR switches.
2. Perform functional tests on HEADPHONE and CENTER CHANNEL OUTPUT jacks and VOL. CONTROL CENTER CHANNEL.

#### L. FILTERS AND TONE CONTROLS

1. Set audio oscillator to 50 Hz and connect to Aux 1 inputs.

2. Set SELECTOR switch to AUX 1. Note output as displayed on distortion analyzer.
3. Set LOW filter switch to 50.
4. Distortion analyzer should indicate a drop of  $-3 \pm 1.5\text{dB}$ .
5. Set LOW filter switch to OUT.
6. Set audio oscillator to 100Hz. Note output as displayed on distortion analyzer.
7. Set LOW filter switch to 100.
8. Distortion analyzer should indicate  $-3 \pm 1.5\text{dB}$ .
9. Set LOW filter switch to OUT.
10. Set TONE CONTROL switch to IN. Set BASS controls to maximum and then to minimum. Distortion analyzer should indicate  $+10 \pm 2\text{dB}$  and then  $-10 \pm 2\text{dB}$ . Set TONE CONTROL switch to OUT.
11. Set audio oscillator to 5KHz. Note output as displayed on distortion analyzer.
12. Set HIGH filter switch to 5K.
13. Distortion analyzer should indicate  $-3 \pm 1.5\text{dB}$ .
14. Set HIGH filter switch to OUT.
15. Set audio oscillator to 9KHz. Note output as indicated on distortion analyzer.
16. Set HIGH filter switch to 9K.
17. Distortion analyzer should indicate  $-3 \pm 1.5\text{dB}$ .
18. Set HIGH filter switch to OUT. Set TONE CONTROL switch to IN.
19. Set audio oscillator to 10KHz. Note output as indicated on distortion analyzer.
20. Set TREBLE controls to maximum and then to minimum.
21. Distortion analyzer should indicate  $+10 \pm 2\text{dB}$  and then  $-10 \pm 2\text{dB}$ .

#### M. BALANCE

1. Set audio oscillator to 1KHz.
2. Set BALANCE control to mechanical center (line on knob pointing to dot on panel).
3. Difference between channel outputs as indicated on distortion analyzer should be  $0 \pm 2\text{dB}$ .

#### N. LOUDNESS

1. With audio oscillator at 1KHz note output as indicated on distortion analyzer.
2. Set TONE CONTROL switch to LOUDNESS.
3. Distortion analyzer should indicate  $-7 \pm 2\text{dB}$ .
4. Set TONE CONTROL switch to OUT.

#### O. CHANNEL SEPARATION

1. Set audio oscillator to 20KHz. Connect oscillator to channel A AUX1 input only, with shorting plug in channel B AUX 1 input. Connect distortion analyzer to PREAMP OUT channel A.
2. Adjust oscillator output until distortion analyzer indicates 0dB.
3. Measure channel B preamp out. Distortion analyzer should indicate -40dB or greater.
4. If indication is less than -40dB, adjust input wires to preamp board until reading is -40dB or greater.
5. Connect distortion analyzer to channel A SYSTEM 1 jacks.
6. Re-connect jumper between PREAMP OUT and AMP IN jacks.
7. Adjust oscillator output for an indication of +20dB on distortion analyzer.
8. Connect distortion analyzer to channel B SYSTEM 1 jacks.
9. Distortion analyzer should indicate -40dB or greater.
10. If indication is less than -40dB, adjust power supply wiring until reading is -40dB or greater.
11. Repeat steps 5, 7, 8, and 9 at 20Hz.
12. If indication is less than -48dB, check power supply filter capacitors.

Figure 10. AC Power Control Box Simplified Schematic

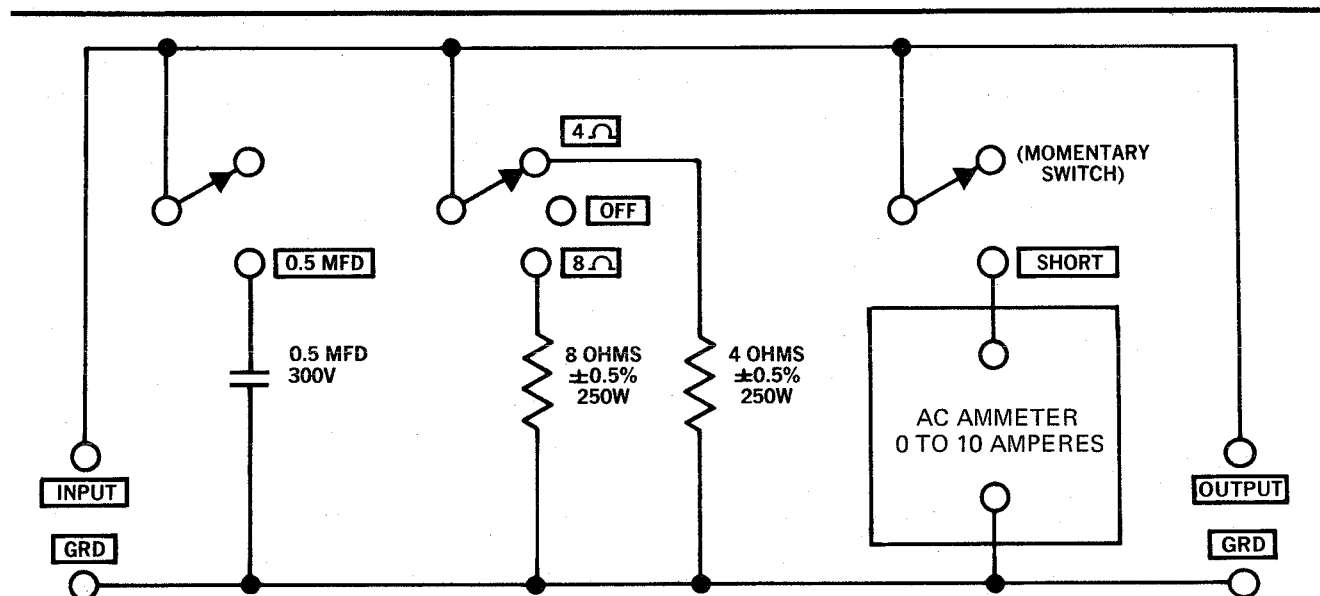
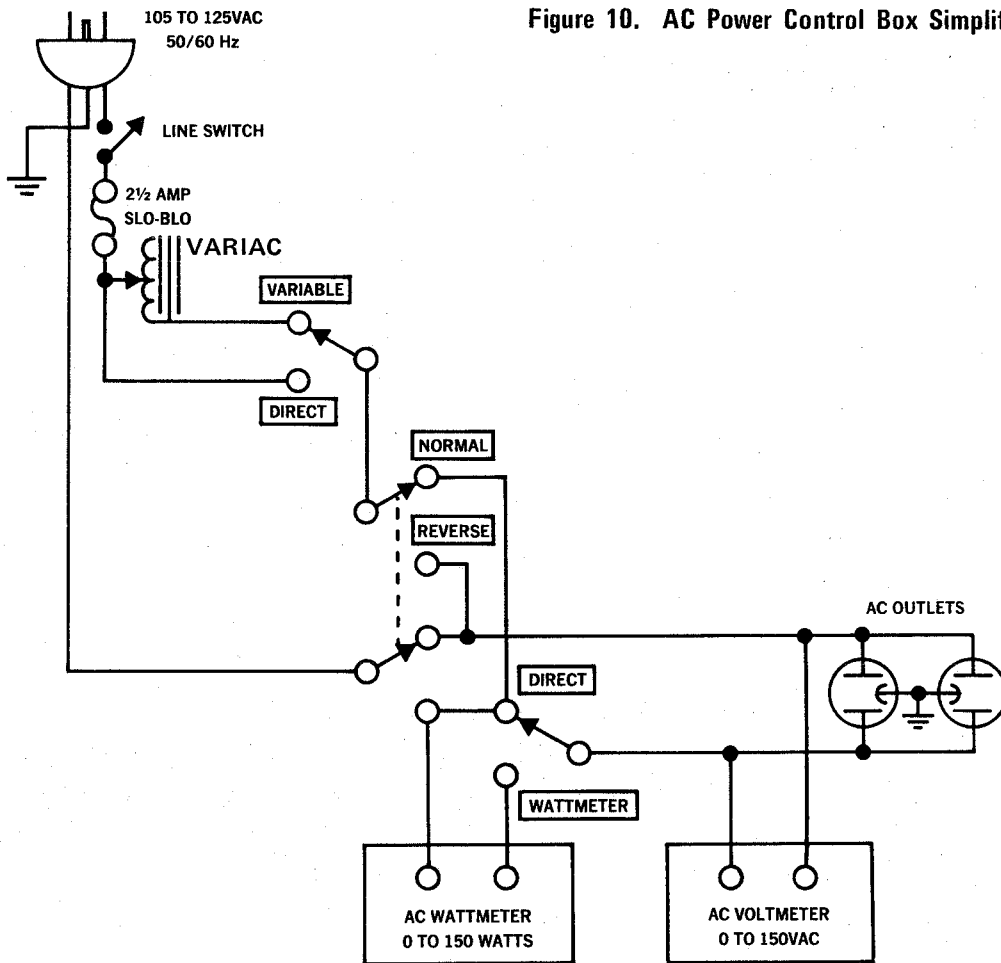

Figure 11. Amplifier Output Load Box Simplified Schematic



## TROUBLE ANALYSIS

The following section is designed to assist in locating troubles. The information given is to help in situations where problems may be difficult to isolate. Any field problems that arise will be covered through service bulletins (supplementary to this manual) that will be issued to all service stations. It is assumed that normal trouble-shooting techniques (i.e. point-to-point signal tracing, oscilloscope analysis, etc.) will be used to isolate problems.

**NOTE:** Performance verification is necessary following any repair.

SYMPTOM	PROCEDURE
1. Excessive line consumption (100 watts or more).	<ul style="list-style-type: none"> <li>a. Check for shorted rectifiers CR601 through CR604, CR701 through CR704, CR705 and CR706.</li> <li>b. Check for shorted transistors Q802 through Q805, Q507, Q508, Q510, Q511. Check for open control R526, 215-1005-1 bias assy. Check T1 for short.</li> </ul>
<p><b>CAUTION:</b> Because the driver and output stages are direct coupled, components may fail as a direct result of an initial component failure. If a shorted semiconductor is found, be sure to check the remaining driver and output components for short or open circuits before re-energizing the amplifier. After replacement of any of these components, increase the Variac voltage slowly while monitoring the wattmeter as described in paragraph C of Performance Verification.</p>	
2. No line consumption or zero bias.	<ul style="list-style-type: none"> <li>a. Check line cord, fuse, transistors Q507, Q508, Q510, Q511, Q802 through Q805, shorted 215-1005-1 bias assy.</li> <li>b. Check for open rectifiers CR601 through CR604, CR701 through 704, CR705 and CR706, or open T1.</li> </ul>
3. High d-c voltage at loudspeaker terminals before time delay circuit is activated.	<ul style="list-style-type: none"> <li>a. Check transistors Q701 through Q703 for leakage, shorted, or open.</li> </ul>
4. High d-c voltage at loudspeaker at all times.	<ul style="list-style-type: none"> <li>a. Check R701 through 705 for open and Q701 for leakage, or open. Check for shorted or open transistors Q802 through Q805, Q507, Q508, Q510, or Q511.</li> </ul>
5. No D-C Balance.	<ul style="list-style-type: none"> <li>a. Check Q501, Q502, R502, and Zener diodes CR501, CR502 (amplifier). Check Q205, Q206, Q201, Q202, R235, and R214 (pre-amplifier).</li> <li>b. Check R501, R503 (amplifier).</li> </ul>

- 6. High hum and noise level.
  - 7. Parasitic Oscillation.
  - 8. Improper clipping.
  - 9. Relay Latching.
- a. Check filter capacitors C4, C5, C503 and C504.
  - a. Check for defective C506, C509, C516, and C505.
  - a. Check for proper adjustment of R541, R542.
  - b. Check transistors Q802 through Q805.
  - a. Check Q701 through 703.
  - b. Check output for proper clipping (positive and negative levels must not vary more than 1 volt at 2KHz).
  - c. Check for high level DC offset at junction of R701 and R702.

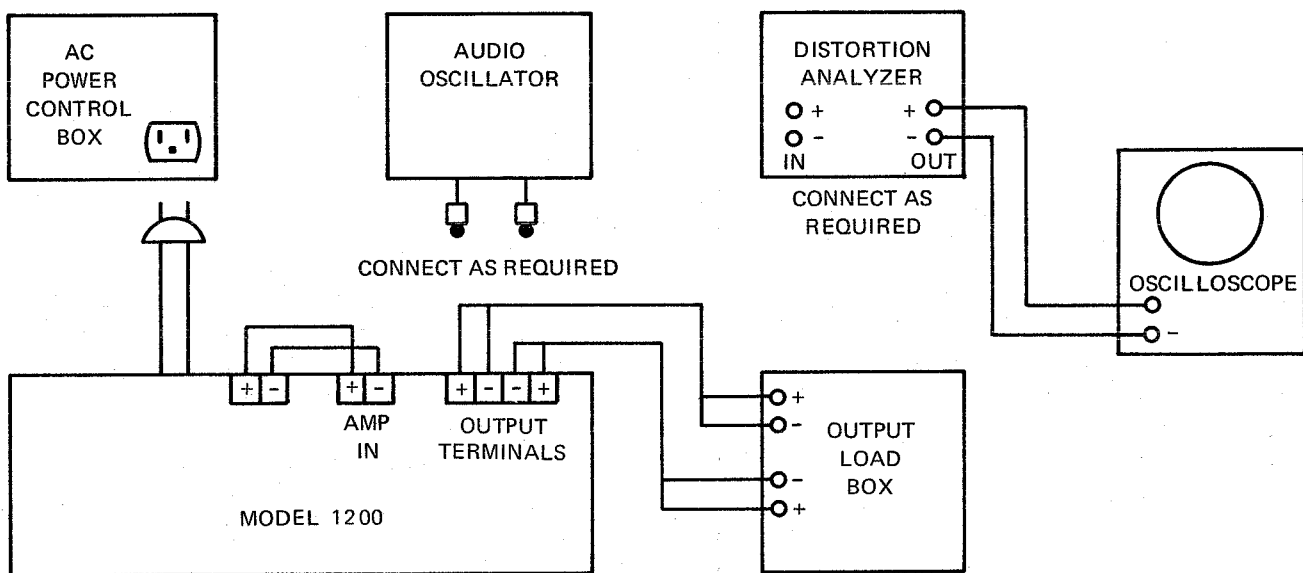

Figure 12. Test Equipment Set-Up

# PARTS LIST

Reference Designation	Description and/or Remarks	Marantz Part Number
<b>INTERCONNECT BOARD COMPONENT ASSEMBLY</b>		
C101	Cap., 150pf, $\pm 10\%$ , 100V	385-1038
C102	Cap., .03uf, $\pm 20\%$ , 100V	383-1002
C103	Cap., 150pf, $\pm 10\%$ , 100V	385-1038
C104	Cap., .03uf, $\pm 20\%$ , 100V	383-1002
R101	Res., C/F, 8.2K, $\pm 5\%$ , $\frac{1}{2}W$	433-4822
R102	Res., C/F, 8.2K, $\pm 5\%$ , $\frac{1}{2}W$	433-4822
R103	Res., Variable, Tandem, 100K	420-1017
R104	Res., Variable, Tandem, 250K	420-1016
R105	Res., C/F, 62K, $\pm 5\%$ , $\frac{1}{2}W$	433-5622
R106	Res., C/F, 10K, $\pm 5\%$ , $\frac{1}{2}W$	433-5102
R107	Res., C/F, 62K, $\pm 5\%$ , $\frac{1}{2}W$	433-5622
R108	Res., C/F, 10K, $\pm 5\%$ , $\frac{1}{2}W$	433-5102
R109	Res., Variable, 100K, Modified	145-1004
R110	Res., Variable, 100K, Modified	145-1004
R111	Res., Variable, 100K, Modified	145-1004
R112	Res., Variable, 100K, Modified	145-1004
S101	Switch, Mode	453-1014
S102	Switch, Tone	453-1015
S103	Switch, Lo Filter	453-1016
S104	Switch, Hi Filter	453-1016
<b>PHONO AMP BOARD COMPONENT ASSEMBLY</b>		
C201	Cap, 3600pf, $\pm 5\%$ , 100V	385-1057
C202	Cap., 1100pf, $\pm 5\%$ , 100V	385-1058
C203	Cap., 1.0uf, $\pm 20\%$ , 250V	386-1008
C204	Cap., .03uf, $\pm 20\%$ , 100V	383-1002
C205	Cap. Elect., 10uf, 25V	381-1034
C206	Cap., .03uf, $\pm 20\%$ , 100V	383-1002
C207	Cap., 680pf, $\pm 5\%$ , 100V	385-1042
C208	Cap., 210pf, $\pm 10\%$ , 100V	385-1063
C209	Cap. Elect., 100uf, 10V	381-1031
C210	Cap. Elect., 220uf, 6.3V	381-1044
C211	Cap., 1.0uf, $\pm 20\%$ , 250V	386-1008
C212	Cap., 39pf, $\pm 10\%$ , 100V	385-1053
C213	Cap., 3600pf, $\pm 5\%$ , 100V	385-1057

Reference Designation	Description and/or Remarks	Marantz Part Number
C214	Cap., 1100pf, $\pm 5\%$ , 100V	385-1058
C215	Cap., 1.0uf, $\pm 20\%$ , 250V	386-1008
C216	Cap., 1600pf, $\pm 10\%$ , 100V	385-1044
C217	Cap Elect., 10uf, 25V	381-1034
C218	Cap., 39pf, $\pm 10\%$ , 100V	385-1053
C219	Cap. Elect., 100uf, 10V	381-1031
C220	Cap., 210pf, $\pm 10\%$ , 100V	385-1063
C221	Cap., 680pf, $\pm 5\%$ , 100V	385-1042
C222	Cap. Elect., 220uf, 6.3V	381-1044
C223	Cap., 1600pf, $\pm 10\%$ , 100V	385-1044
C224	Cap., 1.0uf, $\pm 20\%$ , 250V	386-1008
C225	Cap., 1600pf, $\pm 10\%$ , 100V	385-1044
C226	Cap., 1600pf, $\pm 10\%$ , 100V	385-1044
CR201	Diode, Rectifier	460-1004
CR202	Diode, Rectifier	460-1004
R201	Res. Prec., 91K, $\pm 1\%$ , $\frac{1}{4}W$	431-5910
R202	Res., C/F, 2.2Meg, $\pm 10\%$ , $\frac{1}{4}W$	434-7223
R203	Res. Prec., 68K, $\pm 1\%$ , $\frac{1}{4}W$	431-5680
R204	Res. Prec., 1.1 Meg, $\pm 2\%$ , $\frac{1}{2}W$	439-1013
R205	Res., C/F, 2.2K, $\pm 5\%$ , $\frac{1}{4}W$	434-4222
R206	Res. Prec., 100K, $\pm 2\%$ , $\frac{1}{4}W$	431-6101
R207	Res., C/F, 18K, $\pm 5\%$ , $\frac{1}{4}W$	434-5182
R208	Res., C/F, 270K, $\pm 5\%$ , $\frac{1}{4}W$	434-6272
R209	Res., C/F, 22K, $\pm 5\%$ , $\frac{1}{4}W$	434-5222
R210	Res. Prec., 680 ohm, $\pm 1\%$ , $\frac{1}{4}W$	431-3680
R211	Res., C/F, 200 ohm, $\pm 5\%$ , $\frac{1}{4}W$	434-3202
R212	Res. Prec., 1.1 Meg, $\pm 2\%$ , $\frac{1}{2}W$	439-1013
R213	Res., C/F, 1 Meg, $\pm 5\%$ , $\frac{1}{4}W$	434-7102
R214	Res., Variable, 25K, $\frac{1}{4}W$	420-1005
R215	Res., C/F, 100 ohm, $\pm 5\%$ , $\frac{1}{4}W$	434-3102
R216	Res., C/F, 27K, $\pm 5\%$ , $\frac{1}{4}W$	434-5272
R217	Res., C/F, 100 ohm, $\pm 5\%$ , $\frac{1}{4}W$	434-3102
R218	Res., C/F, 3.9K, $\pm 5\%$ , $\frac{1}{4}W$	434-4392
R219	Res., C/F, 150 ohm, $\pm 5\%$ , $\frac{1}{4}W$	434-3152
R220	Res., C/F, 47K, $\pm 5\%$ , $\frac{1}{4}W$	434-5472
R221	Res. Prec., 1.1 Meg, $\pm 2\%$ , $\frac{1}{2}W$	439-1013
R222	Res., C/F, 2.2 Meg, $\pm 10\%$ , $\frac{1}{4}W$	439-7223

Reference Designation	Description and/or Remarks	Marantz Part Number
R223	Res. Prec., 91K, $\pm 1\%$ , $\frac{1}{4}W$	431-5910
R224	Res. Prec., 1.1 Meg, $\pm 2\%$ , $\frac{1}{2}W$	439-1013
R225	Res. Prec., 68K, $\pm 1\%$ , $\frac{1}{4}W$	431-5680
R226	Res. Prec., 100K, $\pm 2\%$ , $\frac{1}{4}W$	431-6101
R227	Res., C/F, 2.2K, $\pm 5\%$ , $\frac{1}{4}W$	434-4222
R228	Res., C/F, 270K, $\pm 5\%$ , $\frac{1}{4}W$	434-6272
R229	Res., C/F, 18K, $\pm 5\%$ , $\frac{1}{4}W$	434-5182
R230	Res., C/F, 22K, $\pm 5\%$ , $\frac{1}{4}W$	434-5222
R231	Res. Prec., 680 ohm, $\pm 1\%$ , $\frac{1}{4}W$	431-3680
R232	Res., C/F, 1 Meg, $\pm 5\%$ , $\frac{1}{4}W$	434-7102
R233	Res. Prec., 1.1 Meg, $\pm 2\%$ , $\frac{1}{2}W$	439-1013
R234	Res., C/F, 200 ohm, $\pm 5\%$ , $\frac{1}{4}W$	434-3202
R235	Res., Variable, 25K, $\frac{1}{4}W$	420-1005
R236	Res., C/F, 27K, $\pm 5\%$ , $\frac{1}{4}W$	434-5272
R237	Res., C/F, 100 ohm, $\pm 5\%$ , $\frac{1}{4}W$	434-3102
R238	Res., C/F, 100 ohm, $\pm 5\%$ , $\frac{1}{4}W$	434-3102
R239	Res., C/F, 3.9K, $\pm 5\%$ , $\frac{1}{4}W$	434-4392
R240	Res., C/F, 150 ohm, $\pm 5\%$ , $\frac{1}{4}W$	434-3152
R241	Res., C/F, 47K, $\pm 5\%$ , $\frac{1}{4}W$	434-5472
R242	Res. Prec., 1.1 Meg, $\pm 2\%$ , $\frac{1}{2}W$	439-1013
R243	Res., C/F, 30 ohm, $\pm 5\%$ , $\frac{1}{4}W$	434-2302
R244	Res., C/F, 30 ohm, $\pm 5\%$ , $\frac{1}{4}W$	434-2302
Q201	Transistor, NPN	462-1038
Q202	Transistor, NPN	462-1038
Q203	Transistor, PNP	461-1013
Q204	Transistor, NPN	462-1016
Q205	Transistor, NPN	462-1038
Q206	Transistor, NPN	462-1038
Q207	Transistor, PNP	461-1013
Q208	Transistor, NPN	462-1016
<b>X 10 AMP BOARD COMPONENT ASSEMBLY</b>		
C401	Cap., .03uf, $\pm 20\%$ , 100V	383-1002
C402	Cap. Elect., 1uf, 63V	381-1036
C403	Cap. Elect., 1uf, 63V	381-1036
C404	Cap., .03uf, $\pm 20\%$ , 100V	383-1002
C405	Cap. Elect., 47uf, 10V	381-1037

Reference Designation	Description and/or Remarks	Marantz Part Number
C406	Cap., 680pf, $\pm 5\%$ , 100V	385-1042
C407	Cap. Elect., 1uf, 63V	381-1036
C408	Cap., 2000pf, $\pm 10\%$ , 100V	385-1042
C409	Cap., 1100pf, $\pm 5\%$ , 100V	385-1042
C410	Cap. Elect., 100uf, 10V	381-1031
C411	Cap., 100pf, $\pm 10\%$ , 100V	385-1042
C412	Cap. Elect., 2.2uf, 40V	381-1031
C413	Cap. Elect., 1uf, 63V	381-1036
C414	Cap. Elect., 1uf, 63V	381-1036
C415	Cap. Elect., 47uf, 10V	381-1036
C416	Cap., 1100pf, $\pm 5\%$ , 100V	385-1042
C417	Cap. Elect., 1uf, 63V	381-1036
C418	Cap., 680pf, $\pm 5\%$ , 100V	385-1042
C419	Cap., 2000pf, $\pm 10\%$ , 100V	385-1042
C420	Cap., 100pf, $\pm 10\%$ , 100V	385-1042
C421	Cap. Elect., 100uf, 10V	381-1031
C422	Cap. Elect., 2.2uf, 40V	381-1031
CR401	Diode, Rectifier	460-1004
CR402	Diode, Rectifier	460-1004
R401	Res., C/F, 2.2K, $\pm 5\%$ , $\frac{1}{2}W$	433-4222
R402	Res., C/F, 270K, $\pm 5\%$ , $\frac{1}{2}W$	433-6272
R403	Res., C/F, 33K, $\pm 5\%$ , $\frac{1}{4}W$	434-5333
R404	Res., C/F, 7.5K, $\pm 5\%$ , $\frac{1}{4}W$	434-4777
R405	Res., C/F, 22K, $\pm 5\%$ , $\frac{1}{4}W$	434-5222
R406	Res., C/F, 33K, $\pm 5\%$ , $\frac{1}{4}W$	434-5333
R407	Res. Prec., 1.5K, $\pm 1\%$ , $\frac{1}{4}W$	431-4151
R408	Res., C/F, 30 ohm, $\pm 5\%$ , $\frac{1}{2}W$	433-2302
R409	Res. Prec., 15K, $\pm 1\%$ , $\frac{1}{4}W$	431-5151
R410	Res., C/F, 56 ohm, $\pm 5\%$ , $\frac{1}{2}W$	433-2566
R411	Res., C/F, 2.7K, $\pm 5\%$ , $\frac{1}{4}W$	434-4272
R412	Res., C/F, 200 ohm, $\pm 5\%$ , $\frac{1}{4}W$	434-3202
R413	Res., C/F, 30 ohm, $\pm 5\%$ , $\frac{1}{4}W$	434-2302
R414	Res., C/F, 2.2K, $\pm 5\%$ , $\frac{1}{4}W$	434-4222
R415	Res., C/F, 33K, $\pm 5\%$ , $\frac{1}{4}W$	434-5333
R416	Res., C/F, 270K, $\pm 5\%$ , $\frac{1}{4}W$	434-6272
R417	Res., C/F, 7.5K, $\pm 5\%$ , $\frac{1}{4}W$	434-4777
R418	Res., C/F, 22K, $\pm 5\%$ , $\frac{1}{4}W$	434-5222

Reference Designation	Description and/or Remarks	Marantz Part Number
223	Res. Prec., 91K, ±1%, ¼W	431-5910
224	Res. Prec., 1.1 Meg, ±2%, ½W	439-1013
225	Res. Prec., 68K, ±1%, ¼W	431-5680
226	Res. Prec., 100K, ±2%, ¼W	431-6101
227	Res., C/F, 2.2K, ±5%, ¼W	434-4222
228	Res., C/F, 270K, ±5%, ¼W	434-6272
229	Res., C/F, 18K, ±5%, ¼W	434-5182
230	Res., C/F, 22K, ±5%, ¼W	434-5222
231	Res. Prec., 680 ohm, ±1%, ¼W	431-3680
232	Res., C/F, 1 Meg, ±5%, ¼W	434-7102
233	Res. Prec., 1.1 Meg, ±2%, ½W	439-1013
234	Res., C/F, 200 ohm, ±5%, ¼W	434-3202
235	Res., Variable, 25K, ¼W	420-1005
236	Res., C/F, 27K, ±5%, ¼W	434-5272
237	Res., C/F, 100 ohm, ±5%, ¼W	434-3102
238	Res., C/F, 100 ohm, ±5%, ¼W	434-3102
239	Res., C/F, 3.9K, ±5%, ¼W	434-4392
240	Res., C/F, 150 ohm, ±5%, ¼W	434-3152
241	Res., C/F, 47K, ±5%, ¼W	434-5472
242	Res. Prec., 1.1 Meg, ±2%, ½W	439-1013
243	Res., C/F, 30 ohm, ±5%, ¼W	434-2302
244	Res., C/F, 30 ohm, ±5%, ¼W	434-2302
201	Transistor, NPN	462-1038
202	Transistor, NPN	462-1038
203	Transistor, PNP	461-1013
204	Transistor, NPN	462-1016
205	Transistor, NPN	462-1038
206	Transistor, NPN	462-1038
207	Transistor, PNP	461-1013
208	Transistor, NPN	462-1016
<b>X 10 AMP BOARD COMPONENT ASSEMBLY</b>		
01	Cap., .03uf, ±20%, 100V	383-1002
02	Cap. Elect., 1uf, 63V	381-1036
03	Cap. Elect., 1uf, 63V	381-1036
04	Cap., .03uf, ±20%, 100V	383-1002
05	Cap. Elect., 47uf, 10V	381-1037

Reference Designation	Description and/or Remarks	Marantz Part Number
C406	Cap., 680pf, ±5%, 100V	385-1042
C407	Cap. Elect., 1uf, 63V	381-1036
C408	Cap., 2000pf, ±10%, 100V	385-1046
C409	Cap., 1100pf, ±5%, 100V	385-1058
C410	Cap. Elect., 100uf, 10V	381-1031
C411	Cap., 100pf, ±10%, 100V	385-1041
C412	Cap. Elect., 2.2uf, 40V	381-1038
C413	Cap. Elect., 1uf, 63V	381-1036
C414	Cap. Elect., 1uf, 63V	381-1036
C415	Cap. Elect., 47uf, 10V	381-1037
C416	Cap., 1100pf, ±5%, 100V	385-1058
C417	Cap. Elect., 1uf, 63V	381-1036
C418	Cap., 680pf, ±5%, 100V	385-1042
C419	Cap., 2000pf, ±10%, 100V	385-1046
C420	Cap., 100pf, ±10%, 100V	385-1041
C421	Cap. Elect., 100uf, 10V	381-1031
C422	Cap. Elect., 2.2uf, 40V	381-1038
CR401	Diode, Rectifier	460-1009
CR402	Diode, Rectifier	460-1009
R401	Res., C/F, 2.2K, ±5%, ½W	433-4222
R402	Res., C/F, 270K, ±5%, ½W	433-6272
R403	Res., C/F, 33K, ±5%, ¼W	434-5332
R404	Res., C/F, 7.5K, ±5%, ¼W	434-4752
R405	Res., C/F, 22K, ±5%, ¼W	434-5222
R406	Res., C/F, 33K, ±5%, ¼W	434-5332
R407	Res. Prec., 1.5K, ±1%, ¼W	431-4150
R408	Res., C/F, 30 ohm, ±5%, ½W	433-2302
R409	Res. Prec., 15K, ±1%, ¼W	431-5150
R410	Res., C/F, 56 ohm, ±5%, ½W	433-2562
R411	Res., C/F, 2.7K, ±5%, ¼W	434-4272
R412	Res., C/F, 200 ohm, ±5%, ¼W	434-3202
R413	Res., C/F, 30 ohm, ±5%, ¼W	434-2302
R414	Res., C/F, 2.2K, ±5%, ¼W	434-4222
R415	Res., C/F, 33K, ±5%, ¼W	434-5332
R416	Res., C/F, 270K, ±5%, ¼W	434-6272
R417	Res., C/F, 7.5K, ±5%, ¼W	434-4752
R418	Res., C/F, 22K, ±5%, ¼W	434-5222

Reference Designation	Description and/or Remarks	Marantz Part Number
R419	Res., C/F, 33K, ±5%, ¼W	434-5332
R420	Res. Prec., 1.5K, ±1%, ¼W	431-4150
R421	Res., C/F, 200 ohm, ±5%, ¼W	434-3202
R422	Res. Prec., 15K, ±1%, ¼W	431-5150
R423	Res., C/F, 30 ohm, ±5%, ¼W	434-2302
R424	Res., C/F, 200 ohm, ±5%, ¼W	434-3202
R425	Res., C/F, 2.7K, ±5%, ¼W	434-4272
R426	Res., C/F, 56 ohm, ±5%, ¼W	434-2562
Q401	Transistor, NPN	462-1038
Q402	Transistor, NPN	462-1038
Q403	Transistor, PNP	461-1013
Q404	Transistor, NPN	462-1038
Q405	Transistor, NPN	462-1038
Q406	Transistor, PNP	461-1013
<b>TONE AMP BOARD COMPONENT ASSEMBLY</b>		
C301	Cap. Elect., 1uf, 63V	381-1036
C302	Cap., .033uf, ±20%, 100V	385-1022
C303	Cap., .033uf, ±20%, 100V	385-1022
C304	Cap., .001uf, ±10%, 100V	385-1023
C305	Cap., 27pf, ±10%, 100V	385-1036
C306	Cap., .03uf, ±20%, 100V	383-1002
C307	Cap., 680pf, ±5%, 100V	385-1042
C308	Cap. Elect., 10uf, 25V	381-1034
C309	Cap., 1uf, ±20%, 250V	386-1008
C310	Cap., .03uf, ±20%, 100V	383-1002
C311	Cap. Elect., 1uf, 63V	381-1036
C312	Cap., .033uf, ±20%, 100V	385-1022
C313	Cap., .033uf, ±20%, 100V	385-1022
C314	Cap., .001uf, ±10%, 100V	385-1023
C315	Cap., 27pf, ±10%, 100V	385-1036
C316	Cap., 680pf, ±5%, 100V	385-1042
C317	Cap. Elect., 10uf, 25V	381-1034
C318	Cap., 1uf, ±20%, 250V	386-1008
R301	Res., C/F, 270K, ±5%, ¼W	434-6272
R302	Res., C/F, 18K, ±5%, ¼W	434-5182

Reference Designation	Description and/or Remarks	Marantz Part Number
R303	Res., C/F, 10K, ±5%, ¼W	434-5102
R304	Res., C/F, 18K, ±5%, ½W	433-5182
R305	Res., C/F, 10K, ±5%, ¼W	434-5102
R306	Res., C/F, 27K, ±5%, ½W	433-5272
R307	Res., C/F, 1 Meg, ±5%, ¼W	434-7102
R308	Res., C/F, 22K, ±5%, ¼W	434-5222
R309	Res., C/F, 7.5K, ±5%, ¼W	434-4752
R310	Res., C/F, 30 ohm, ±5%, ¼W	434-2302
R311	Res., C/F, 39K, ±5%, ¼W	434-5392
C312	Res., C/F, 56 ohm, ±5%, ¼W	434-2562
R313	Res., C/F, 2.7K, ±5%, ¼W	434-4272
R314	Res., C/F, 300 ohm, ±5%, ½W	433-3302
R315	Res., C/F, 270K, ±5%, ¼W	434-6272
R316	Res., C/F, 270K, ±5%, ¼W	434-6272
R317	Res., C/F, 10K, ±5%, ¼W	434-5102
R318	Res., C/F, 18K, ±5%, ¼W	434-5182
R319	Res., C/F, 10K, ±5%, ¼W	434-5102
R320	Res., C/F, 18K, ±5%, ¼W	434-5182
R321	Res., C/F, 27K, ±5%, ¼W	434-5272
R322	Res., C/F, 1 Meg, ±5%, ¼W	434-7102
R323	Res., C/F, 22K, ±5%, ¼W	434-5222
R324	Res., C/F, 7.5K, ±5%, ¼W	434-4752
R325	Res., C/F, 39K, ±5%, ¼W	434-5392
R326	Res., C/F, 30 ohm, ±5%, ¼W	434-2302
R327	Res., C/F, 2.7K, ±5%, ¼W	434-4272
R328	Res., C/F, 56 ohm, ±5%, ¼W	434-2562
R329	Res., C/F, 270K, ±5%, ¼W	433-6272
R330	Res., C/F, 300 ohm, ±5%, ¼W	434-3302
Q301	Transistor, NPN	462-1038
Q302	Transistor, NPN	462-1038
Q303	Transistor, PNP	461-1013
Q304	Transistor, NPN	462-1038
Q305	Transistor, NPN	462-1038
Q306	Transistor, PNP	461-1013
<b>POWER AMPLIFIER BOARD COMPONENT ASSEMBLY</b>		
	Transistor Socket	368-1000

# PARTS LIST

Reference Designation	Description and/or Remarks	Marantz Part Number
L501	Toroid	147-1007
C501	Cap., 150pf, ±10%, 100V	385-1038
C502	Cap. Elect., 10uf, 25V	381-1034
C503	Cap. Elect., 10uf, 25V	381-1034
C504	Cap. Elect., 10uf, 25V	381-1034
C505	Cap., 47pf, ±10%, 100V	385-1040
C506	Cap., 680pf, ±5%, 100V	385-1042
C507	Cap. Elect., 220uf, 6.3V	381-1044
C508	Cap., 36 pf, ±5%, 100V	385-1064
C509	Cap., 36pf, ±5%, 300V	385-1018
C510	Cap., 0.1uf, ±10%, 250V	386-1000
C511	Cap., 0.1uf, ±10%, 250V	386-1000
C512	Cap., 410pf, ±10%, 100V	385-1055
C513	Cap., 0.22uf, ±10%, 250V	386-1017
C514	Cap., 1600pf, ±10%, 300V	385-1020
C515	Cap., 1600pf, ±10%, 300V	385-1020
C516	Cap., 0.1uf, ±10%, 250V	386-1000
C517	Cap., 1.0uf, ±20%, 100V	388-1001
C518	Cap., 130pf, ±10%, 300V	385-1019
CR501	Diode, Zener	459-1006
CR502	Diode, Zener	459-1006
R501	Res., C/F, 7.5K, ±5%, ½W	433-4752
R502	Res., Variable, 2K, 2W	420-1000
R503	Res., C/F, 4.7K, ±5%, ½W	433-4472
R504	Res., C/F, 100K, ±5%, ¼W	434-6102
R505	Res., C/F, 470K, ±5%, ¼W	434-6472
R506	Res., C/F, 1K, ±5%, ¼W	434-4102
R507	Res., C/F, 100K, ±5%, ¼W	434-6102
R508	Res., C/F, 7.5K, ±5%, ½W	433-4752
R509	Res., C/F, 3.3K, ±5%, ¼W	434-4332
R510	Res., C/F, 8.2K, ±5%, ¼W	434-4822
R511	Res., C/F, 680 ohm, ±5%, ¼W	434-3682
R512	Res., C/F, 7.5K, ±5%, ½W	433-4752
R513	Res. Prec., 1K, ±1%, ¼W	431-4100
R514	Res., C/F, 2K, ±5%, ¼W	434-4202
R515	Res., C/F, 27 ohm, ±5%, ½W	433-2272
R516	Res., C/F, 220 ohm, ±5%, ¼W	434-3222

Reference Designation	Description and/or Remarks	Marantz Part Number
R517	Res., W/W, 1.2K, ±10%, 2W	436-4123
R518	Res., W/W, 1.2K, ±10%, 2W	436-4123
R519	Res. Prec., 20K, ±1%, ¼W	431-5200
R520	Res., C/F, 100K, ±5%, ¼W	434-6102
R521	Res., C/F, 300 ohm, ±5%, ¼W	434-3302
R522	Res., C/F, 560 ohm, ±5%, ½W	433-3562
R523	Res., C/F, 560 ohm, ±5%, ½W	433-3562
R524	Res., C/F, 27K, ±5%, ¼W	434-5272
R525	Res., C/F, 27K, ±5%, ¼W	434-5272
R526	Res., Variable, 1K, 2W	420-1011
R527	Res., C/F, 47 ohm, ±5%, ½W	433-2472
R528	Res., C/F, 47 ohm, ±5%, ½W	433-2472
R529	Res., C/C, 39 ohm, ±10%, 1W	423-2392
R530	Res., C/C, 39 ohm, ±10%, 1W	423-2392
R531	Res., W/W, 0.1ohm, ±5%, 5W	145-1002
R532	Res., W/W, 0.1 ohm, ±5%, 5W	145-1002
R533	Res., W/W, 0.15 ohm, ±10%, 5W	428-0153
R534	Res., W/W, 0.15 ohm, ±10%, 5W	428-0153
R535	Res., W/W, 0.15 ohm, ±10%, 5W	428-0153
R536	Res., W/W, 0.15 ohm, ±10%, 5W	428-0153
R537	Res., C/F, 330 ohm, ±5%, ¼W	434-3332
R538	Res., C/F, 330 ohm, ±5%, ¼W	434-3332
R539	Res., C/C, 27 ohm, ±5%, 2W	424-2272
R540	Res., C/F, 2.2K, ±5%, ½W	433-4222
R541	Res., Variable, 2.5K, ¼W	420-1019
R542	Res., Variable, 2.5K, ¼W	420-1019
R543	Res., C/F, 2.2K, ±5%, ½W	433-4222
R544	Res., C/F, 1K, ±5%, ½W	433-4102
R545	Res., C/F, 1K, ±5%, ½W	433-4102
R546	Res., BWH, 1.0 ohm, ±5%, 2W	436-1102
R547	Res., C/F, 2.2K, ±5%, ¼W	434-4222
R548	Res., C/F, 2.7K, ±5%, ¼W	434-4272
R549	Res., C/F, 10K, ±5%, ¼W	434-5102
R550	Res., C/F, 1K, ±5%, ¼W	434-4102
R551	Res., C/F, 270K, ±5%, ¼W	434-6272
Q501	Transistor, NPN	462-1038
Q502	Transistor, NPN	462-1038
Q503	Transistor, PNP	461-1037

Reference Designation	Description and/or Remarks	Marantz Part Number
Q504	Transistor, NPN	462-1044
Q505	Transistor, PNP	461-1036
Q506	Transistor, NPN	462-1042
Q507	Transistor, PNP	461-1003
Q508	Transistor, NPN	462-1004
Q509	Not used	
Q510	Transistor, NPN	462-1040
Q511	Transistor, PNP	461-1034
Q512	Not used	
Q513	Not used	
Q514	Not used	
Q515	Not used	
Q516	Transistor, NPN	462-1035
Q517	Transistor, PNP	461-1030
Q518	Transistor, PNP	461-1013
Q519	Transistor, PNP	461-1013
Q802	Transistor, PNP	461-1031
Q803	Transistor, NPN	462-1036
Q804	Transistor, PNP	461-1031
Q805	Transistor, NPN	462-1036
C801	Cap., 0.1uf, ±10%, 250V	386-1000
CR801	Diode	460-1011
Q801	Transistor, NPN	462-1043
	Heat Sensor Assy.	215-1006-1
	<b>POWER SUPPLY BOARD COMPONENT ASSEMBLY</b>	
C601	Cap. Elect., 470uf, 40V	381-1022
C602	Cap. Elect., 470uf, 40V	381-1022
C603	Cap. Elect., 470uf, 40V	381-1022
C604	Cap. Elect., 100uf, 40V	381-1013
C605	Cap. Elect., 100uf, 40V	381-1013
C606	Cap. Elect., 470uf, 40V	381-1022
C607	Cap. Elect., 470uf, 40 V	381-1022
C608	Cap. Elect., 470uf, 40V	381-1022
C609	Cap. Elect., 680uf, 16V	381-1008
C610	Cap. Elect., 680uf, 16V	381-1008
C611	Cap. Elect., 680uf, 16V	381-1008

Reference Designation	Description and/or Remarks	Marantz Part N
C612	Cap. Elect., 680uf, 16V	381-
CR601	Diode	460-
CR602	Diode	460-
CR603	Diode	460-
CR604	Diode	460-
CR605	Diode, Zener	459-
CR606	Diode, Zener	459-
R601	Res., C/F, 10 ohm, ±5%, ½W	433-2
R602	Res., C/F, 10 ohm, ±5%, ½W	433-2
R603	Res., C/F, 10 ohm, ±5%, ½W	433-2
R604	Res., C/F, 10 ohm, ±5%, ½W	433-2
R605	Res., C/F, 240 ohm, ±5%, ½W	433-3
R606	Res., C/F, 750 ohm, ±5%, ½W	433-3
R607	Res., C/F, 750 ohm, ±5%, ½W	433-3
R608	Res., C/F, 240 ohm, ±5%, ½W	433-3
R609	Res., C/F, 200 ohm, ±5%, ½W	433-3
R610	Res., C/F, 200 ohm, ±5%, ½W	433-3
R611	Res., C/F, 120 ohm, ±5%, ½W	433-3
R612	Res., C/F, 120 ohm, ±5%, ½W	433-3
Q601	Transistor, NPN	462-1
Q602	Transistor, PNP	461-1
	<b>RECTIFIER/RELAY BOARD COMPONENT ASSEMBLY</b>	
C701	Cap. Elect., 22uf, 25V	381-1
C702	Cap. Elect., 220uf, 6.3V	381-1
C703	Not used	
C704	Not used	
C705	Cap. Elect., 22uf, 63V	381-11
CR701	Diode	460-10
CR702	Diode	460-10
CR703	Diode	460-10
CR704	Diode	460-10
CR705	Diode	460-10
CR706	Diode	460-10
CR707	Diode, Zener	459-10
	Chassis, Fastener	568-10



Reference Designation	Description and/or Remarks	Marantz Part Number
1504	Transistor, NPN	462-1044
1505	Transistor, PNP	461-1036
1506	Transistor, NPN	462-1042
1507	Transistor, PNP	461-1003
1508	Transistor, NPN	462-1004
1509	Not used	
1510	Transistor, NPN	462-1040
1511	Transistor, PNP	461-1034
1512	Not used	
1513	Not used	
1514	Not used	
1515	Not used	
1516	Transistor, NPN	462-1035
1517	Transistor, PNP	461-1030
1518	Transistor, PNP	461-1013
1519	Transistor, PNP	461-1013
1802	Transistor, PNP	461-1031
1803	Transistor, NPN	462-1036
1804	Transistor, PNP	461-1031
1805	Transistor, NPN	462-1036
1801	Cap., 0.1uf, ±10%, 250V	386-1000
1801	Diode	460-1011
1801	Transistor, NPN	462-1043
	Heat Sensor Assy.	215-1006-1
	<b>POWER SUPPLY BOARD COMPONENT ASSEMBLY</b>	
1601	Cap. Elect., 470uf, 40V	381-1022
1602	Cap. Elect., 470uf, 40V	381-1022
1603	Cap. Elect., 470uf, 40V	381-1022
1604	Cap. Elect., 100uf, 40V	381-1013
1605	Cap. Elect., 100uf, 40V	381-1013
1606	Cap. Elect., 470uf, 40V	381-1022
1607	Cap. Elect., 470uf, 40V	381-1022
1608	Cap. Elect., 470uf, 40V	381-1022
1609	Cap. Elect., 680uf, 16V	381-1008
1610	Cap. Elect., 680uf, 16V	381-1008
1611	Cap. Elect., 680uf, 16V	381-1008

Reference Designation	Description and/or Remarks	Marantz Part Number
C612	Cap. Elect., 680uf, 16V	381-1008
CR601	Diode	460-1013
CR602	Diode	460-1013
CR603	Diode	460-1013
CR604	Diode	460-1013
CR605	Diode, Zener	459-1001
CR606	Diode, Zener	459-1001
R601	Res., C/F, 10 ohm, ±5%, ½W	433-2102
R602	Res., C/F, 10 ohm, ±5%, ½W	433-2102
R603	Res., C/F, 10 ohm, ±5%, ½W	433-2102
R604	Res., C/F, 10 ohm, ±5%, ½W	433-2102
R605	Res., C/F, 240 ohm, ±5%, ½W	433-3242
R606	Res., C/F, 750 ohm, ±5%, ½W	433-3752
R607	Res., C/F, 750 ohm, ±5%, ½W	433-3752
R608	Res., C/F, 240 ohm, ±5%, ½W	433-3242
R609	Res., C/F, 200 ohm, ±5%, ½W	433-3202
R610	Res., C/F, 200 ohm, ±5%, ½W	433-3202
R611	Res., C/F, 120 ohm, ±5%, ½W	433-3122
R612	Res., C/F, 120 ohm, ±5%, ½W	433-3122
Q601	Transistor, NPN	462-1019
Q602	Transistor, PNP	461-1014
	<b>RECTIFIER/RELAY BOARD COMPONENT ASSEMBLY</b>	
C701	Cap. Elect., 22uf, 25V	381-1046
C702	Cap. Elect., 220uf, 6.3V	381-1044
C703	Not used	
C704	Not used	
C705	Cap. Elect., 22uf, 63V	381-1040
CR701	Diode	460-1014
CR702	Diode	460-1014
CR703	Diode	460-1014
CR704	Diode	460-1014
CR705	Diode	460-1013
CR706	Diode	460-1013
CR707	Diode, Zener	459-1005
	Chassis, Fastener	568-1000

Reference Designation	Description and/or Remarks	Marantz Part Number
K701	Relay, DPDT	410-1000
R701	Res., C/F, 10K, ±5%, ½W	433-5102
R702	Res., C/F, 7.5K, ±5%, ½W	433-4752
R703	Res., C/F, 75K, ±5%, ½W	433-5752
R704	Res., C/F, 82K, ±5%, ½W	433-5822
R705	Res., C/F, 15K, ±5%, ½W	433-5152
R706	Res., C/F, 27K, ±5%, ½W	433-5272
R707	Res., C/F, 180K, ±5%, ½W	433-6182
R708	Res., W/W, 430 ohm, ±5%, 5W	428-3432
R709	Res., W/W, 2.2K, ±5%, 2W	436-4222
R710	Res., W/W, 2.2K, ±5%, 2W	436-4222
R711	Res., W/W, 220 ohm, ±10%, 2W	436-3223
R712	Res., C/C, 120 ohm, ±5%, 1W	423-3122
R713	Res., C/C, 120 ohm, ±5%, 1W	423-3122
R714	Res., C/F, 22K, ±5%, ½W	433-5222
R715	Res., C/F, 22K, ±5%, ½W	433-5222
Q701	Transistor, NPN	462-1000
Q702	Transistor, NPN	462-1007
Q703	Transistor, NPN	462-1000
	<b>CHASSIS ASSEMBLY</b>	
C4	Cap., Elect., 20,000uf, 60V	381-1041
C5	Cap., Elect., 20,000uf, 60V	381-1041
C1	Cap., .01uf, -20%, 1400V +80%	383-1006
C2	Cap., .01uf, -20%, 1400V +80%	383-1006
C3	Cap., .01uf, -20%, 1400V +80%	383-1006
C6	Cap., 330pf, ±10%, 100V	385-1062
C7	Cap., 330pf, ±10%, 100V	385-1062
R1	Res., C/F, 56K, ±5%, 1/2W	433-5562
R2	Res., C/F, 56K, ±5%, 1/2W	433-5562
R3	Res., C/F, 56K, ±5%, 1/2W	433-5562
R4	Res., C/F, 56K, ±5%, 1/2W	433-5562
R5	Res., C/F, 22K, ±5%, 1/2W	433-5222
R6	Res., C/F, 10K, ±5%, 1/2W	433-5102

Reference Designation	Description and/or Remarks	Marantz Part Number
R7	Res., C/F, 22K, ±5%, 1/2W	433-5222
R8	Res., C/F, 10K, ±5%, 1/2W	433-5102
R9	Res., C/F, 100K, ±5%, 1/4W	434-6102
R10	Res., C/F, 100K, ±5%, 1/4W	434-6102
R11	Res., Variable, 100K, 2W	420-1015
T1	Transformer, Power	440-1007
F1	Fuse, 6 Amp, 250V	451-1013
S1	Switch, Selector	453-1000
S2	Switch, Tape Monitor	453-1006
S3	Switch, Slide	452-1002
S4	Switch, Power	452-1004
S5	Switch, Speaker	453-1003
XDS1	Socket Assy., Light Foot, Plastic	481-1002 567-1000
TB2, TB3	Speaker Terminal Strip	362-1002

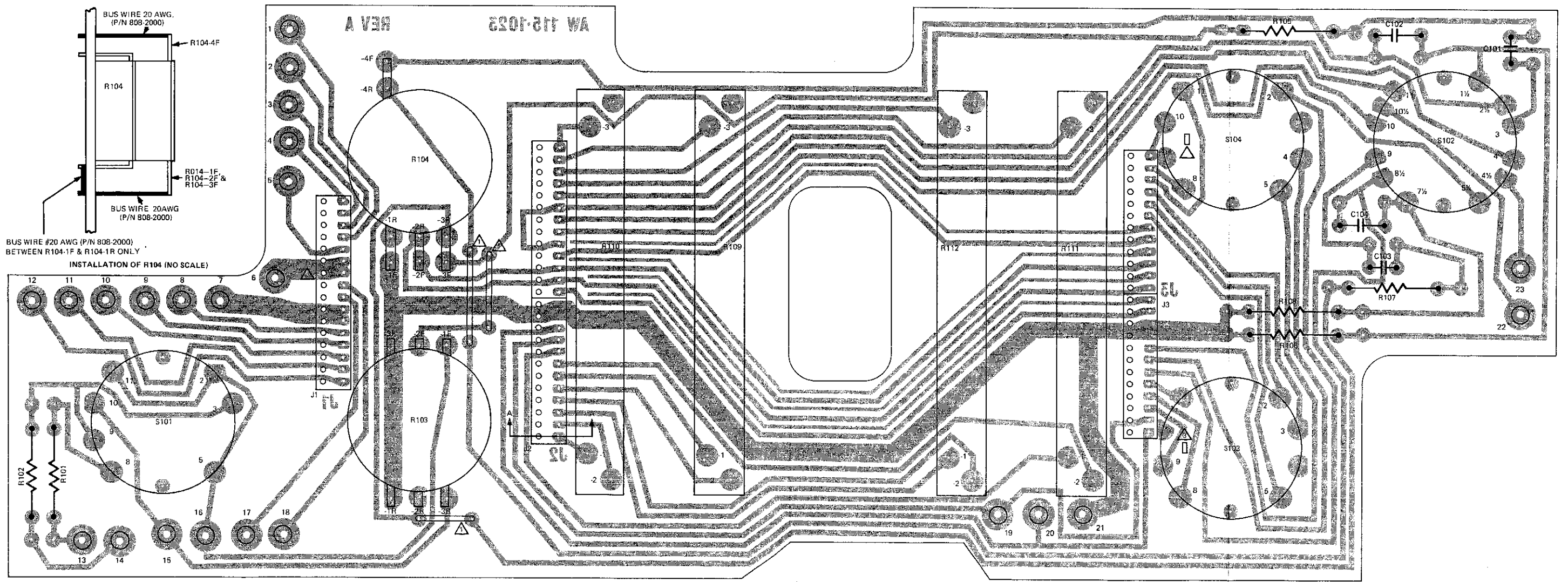

COMPONENT SIDE SHOWN  
CONDUCTOR SIDE OPPOSITE

Figure 13. Interconnect Board – A1 Component Assembly Diagram

X

X

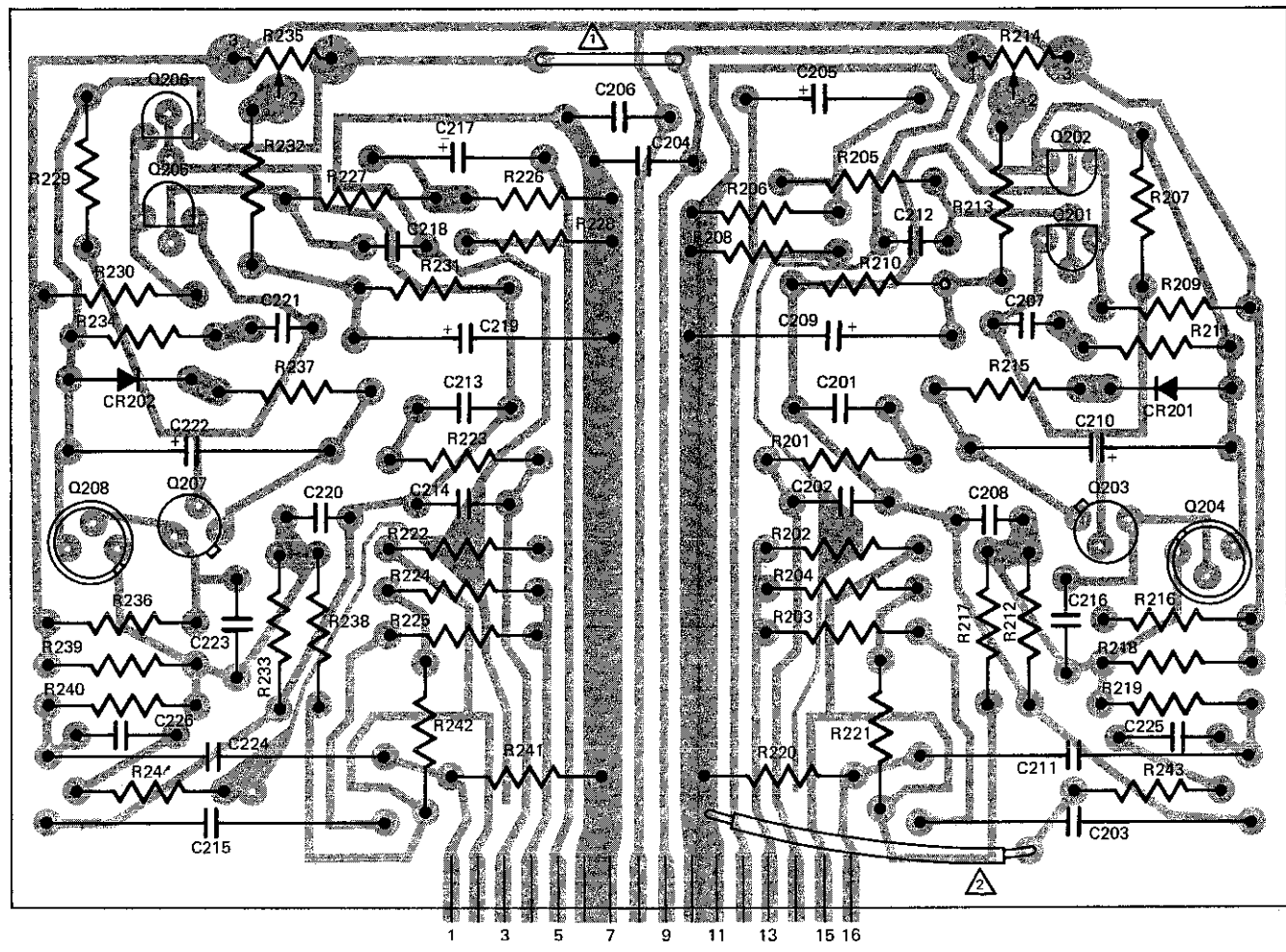

Figure 14. Phono Amplifier Board - A2 Component Assembly Diagram

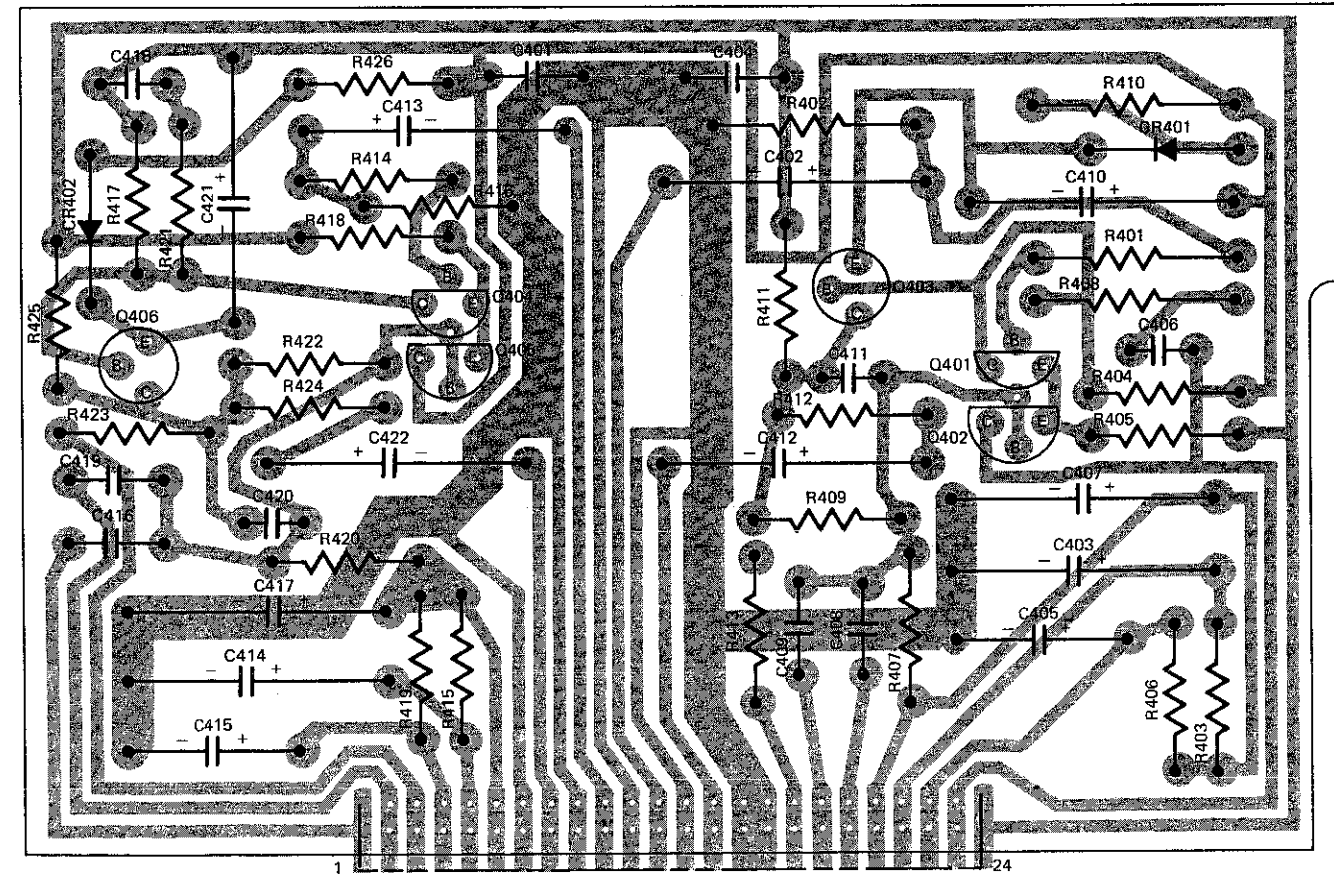

Figure 15. X10 Amplifier Board - A3 Component Assembly Diagram



Figure 16. Tone Amplifier Board - A4 Component Assembly Diagram

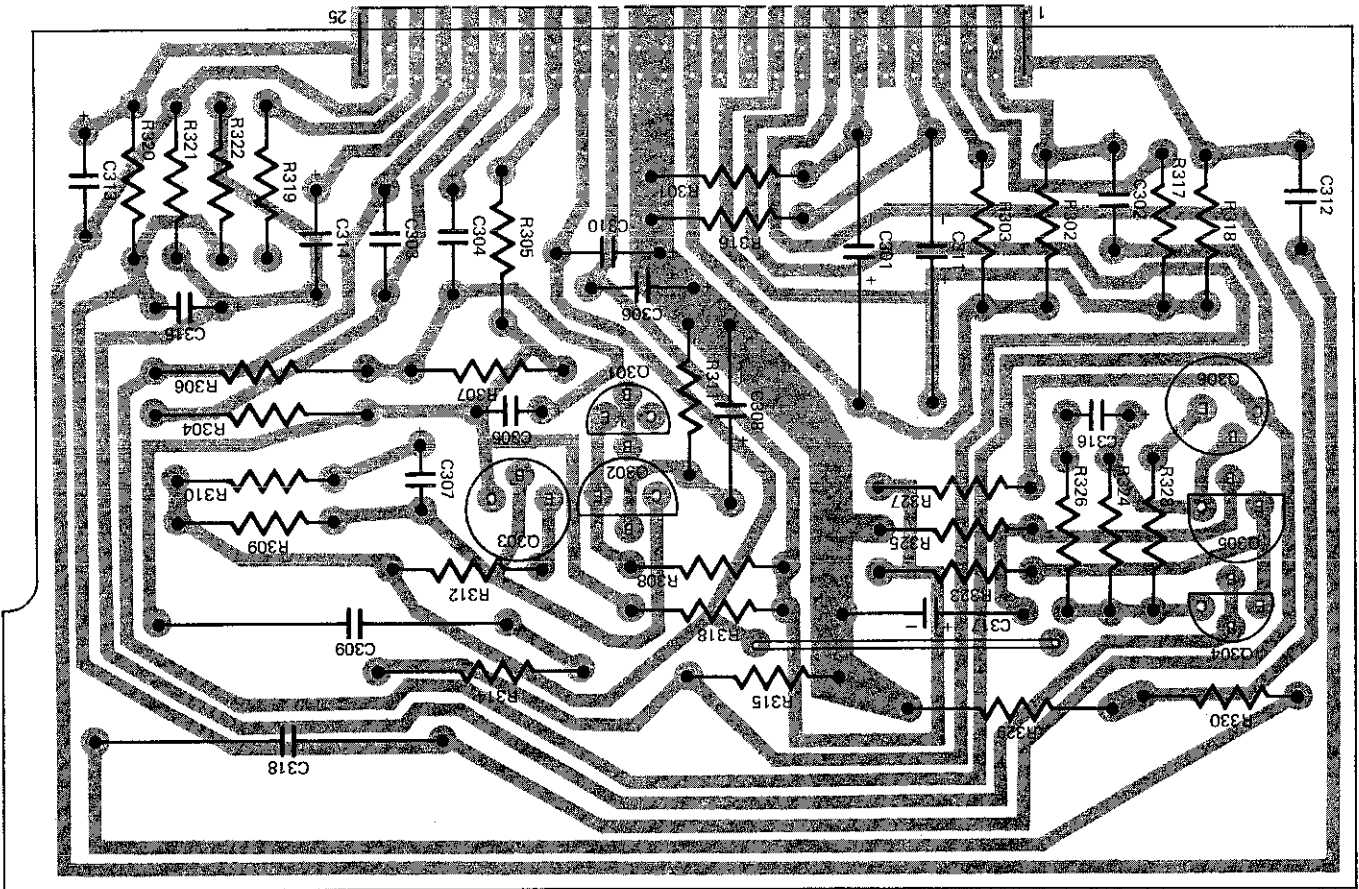

Figure 17. Power Amplifier Board – A5/A6 Component Assembly Diagram

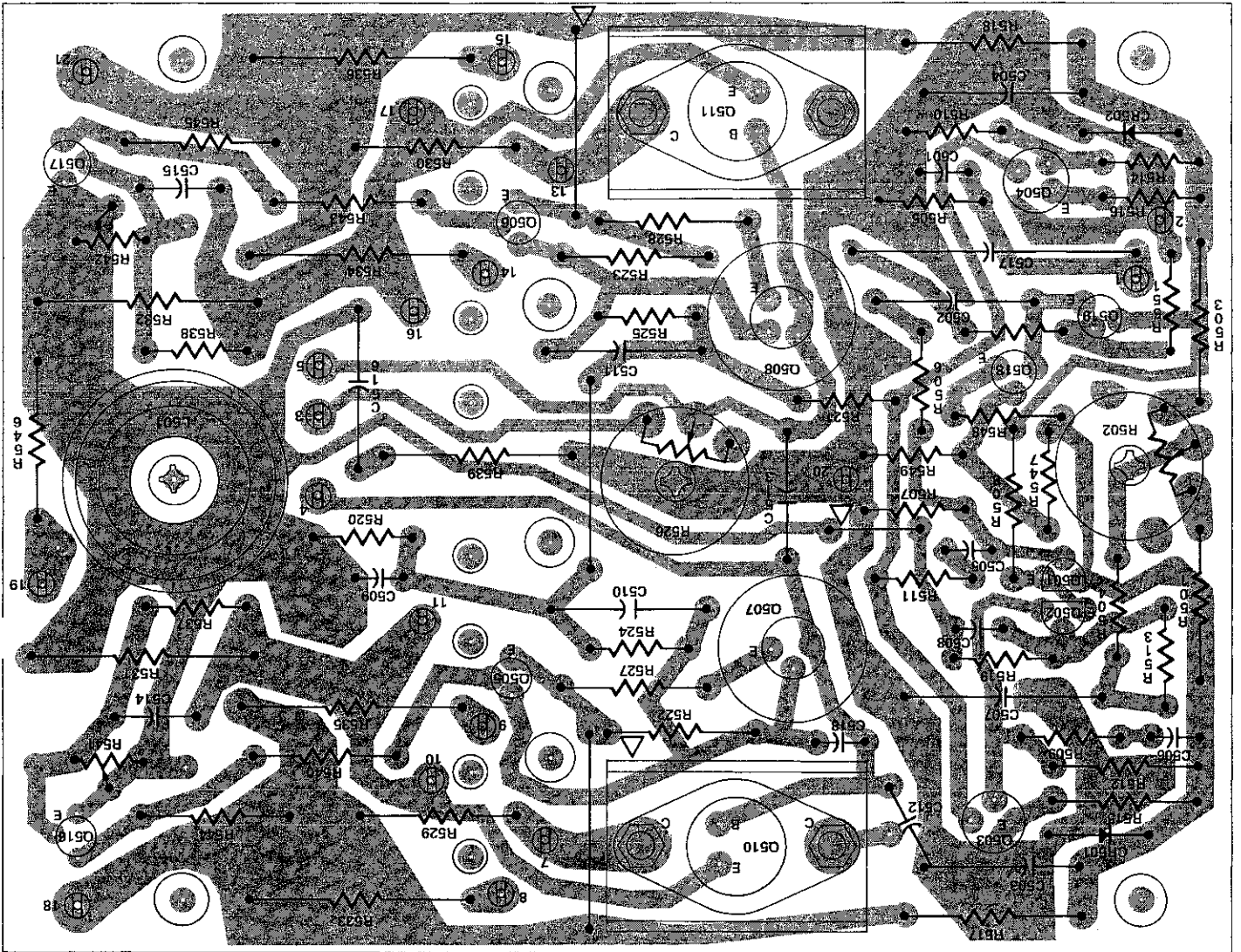
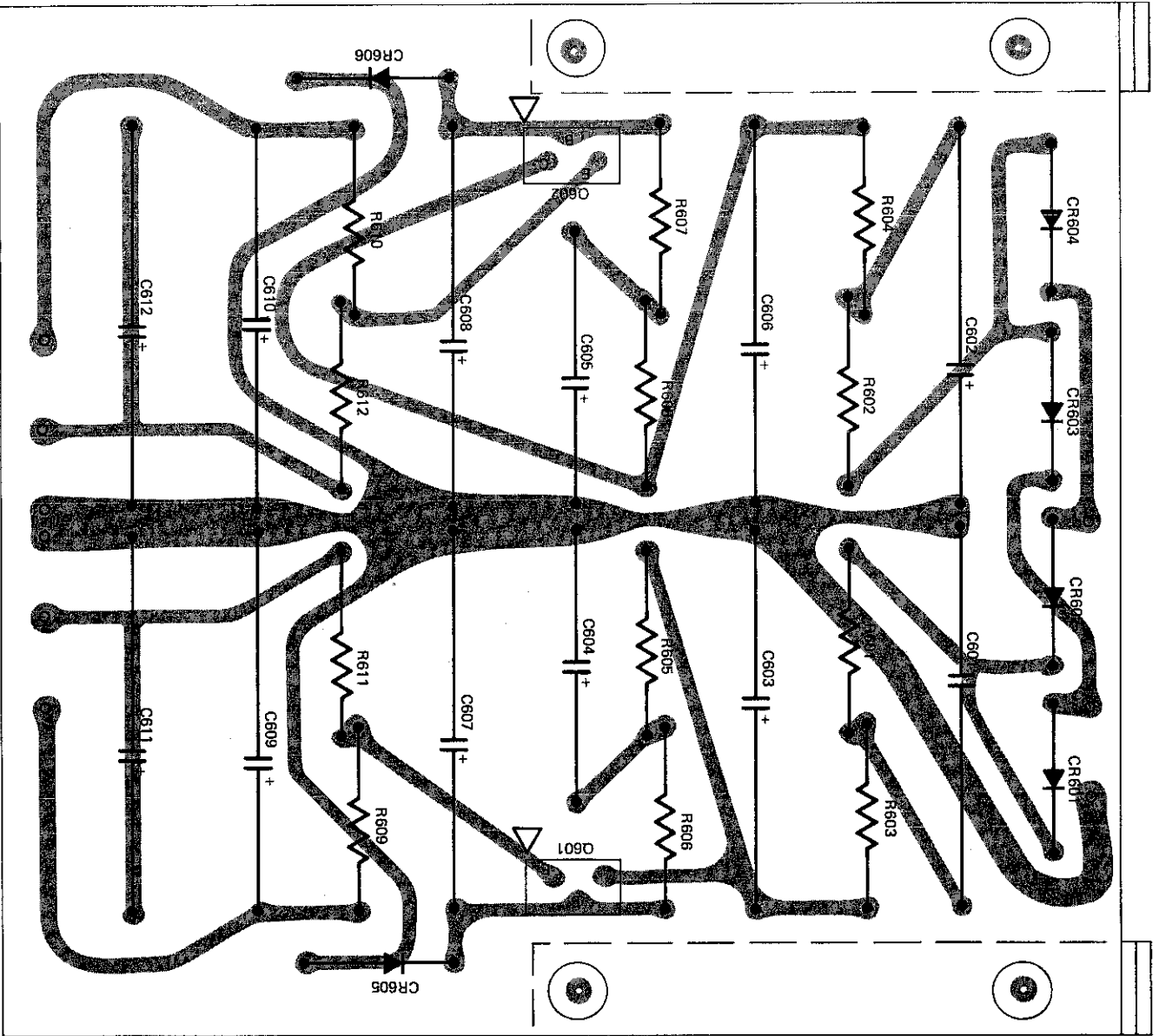
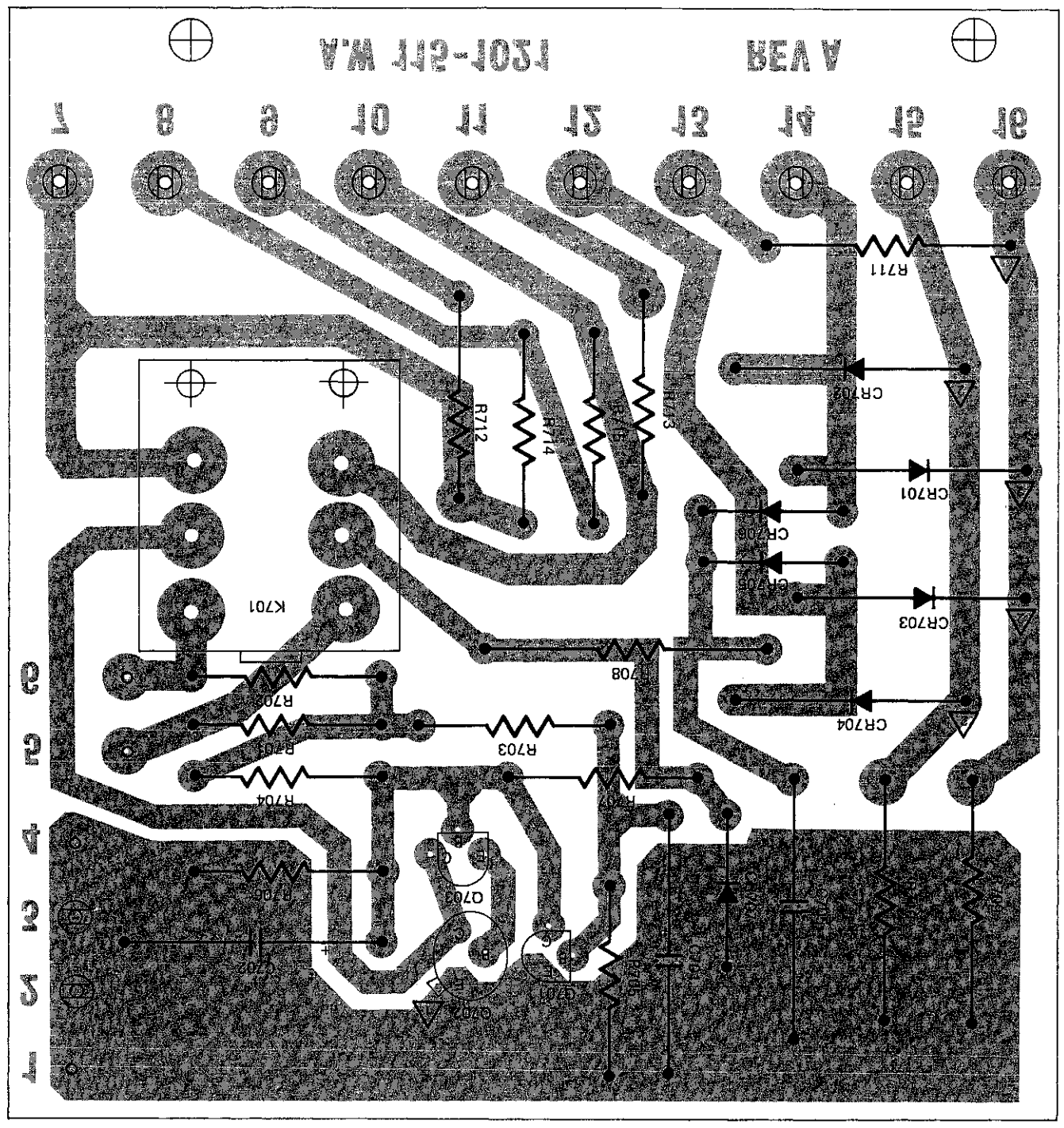

Figure 18. Power Supply Board – A7 Component Assembly Diagram



X

Figure 19. Rectifier/Relay Board - A8 Component Assembly Diagram



X



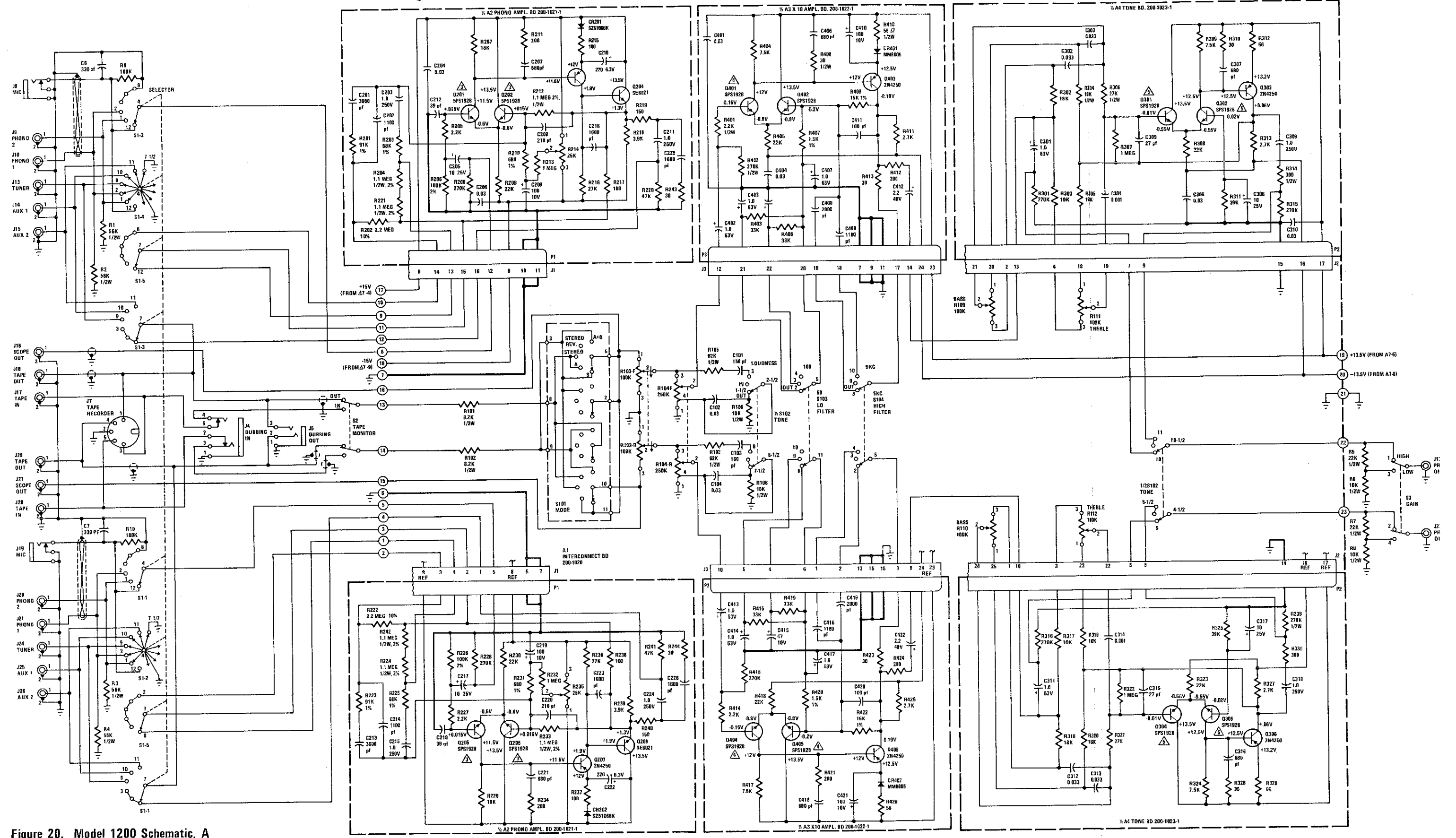
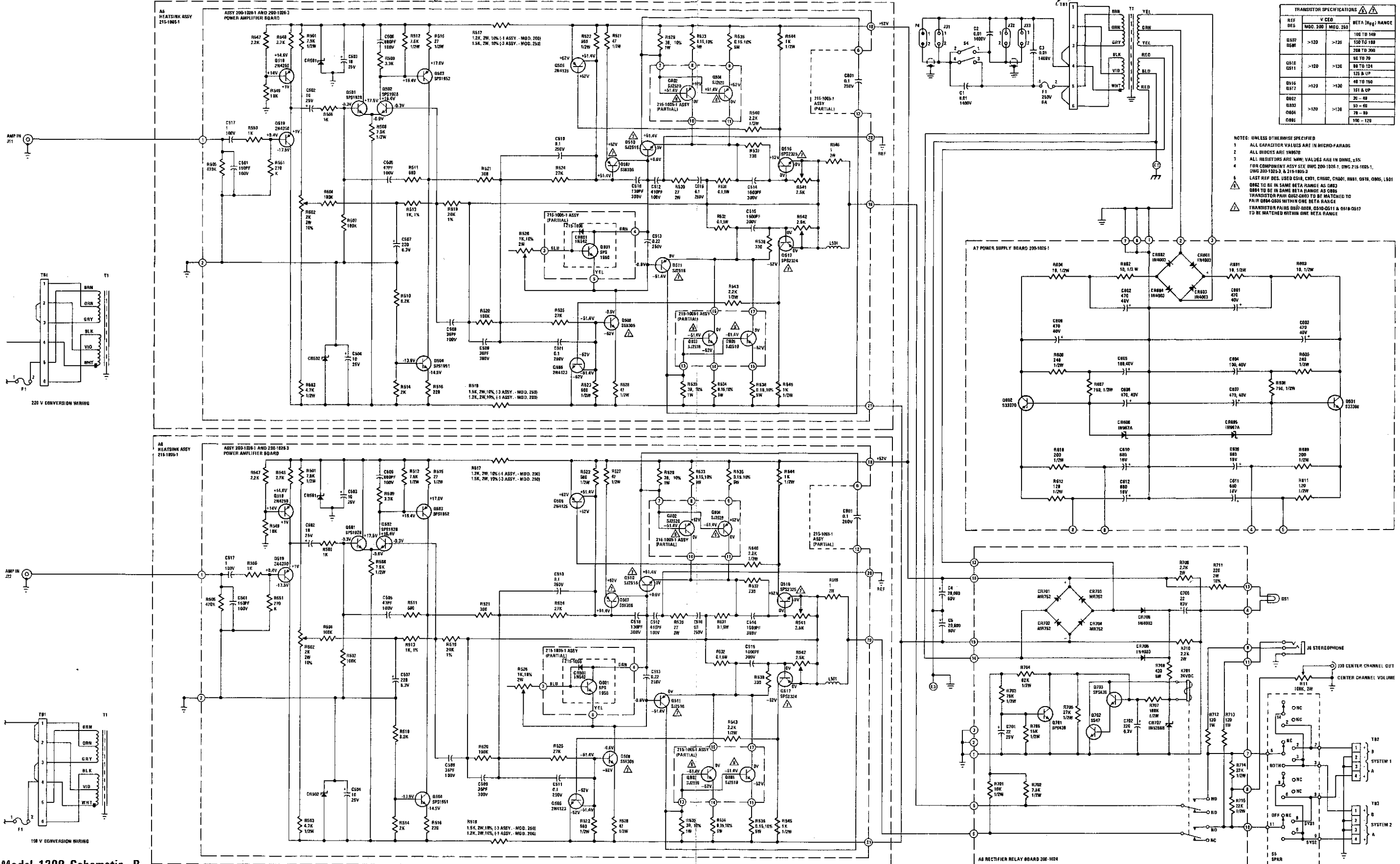

Figure 20. Model 1200 Schematic, A



REF DES	V CEO		BETA (h <sub>FE</sub> ) RANGE
	MOD. 200	MOD. 250	
Q507	>120	>120	100 TO 140
Q508			150 TO 180
			200 TO 300
Q519	>120	>120	50 TO 70
Q520			60 TO 120
			120 & UP
Q509	>120	>120	40 TO 100
Q510			10 & UP
Q802			20 - 40
Q803	>120	>120	40 - 60
Q804			70 - 90
Q805			100 - 120

NOTES: UNLESS OTHERWISE SPECIFIED  
 1 ALL CAPACITOR VALUES ARE IN MICRO-FARADS  
 2 ALL RESISTORS ARE 1/8W  
 3 ALL RESISTORS ARE 5% UNLESS OTHERWISE SPECIFIED  
 4 FOR COMPONENT ASSY SEE BWC 200-102-1, CWC 215-105-1, CWC 205-105-1, & 215-105-2  
 5 LAST REF. USED C81, C82, C83, C84, C85, C86, C87, C88, C89, C90, C91, C92, C93, C94, C95, C96, C97, C98, C99, C100  
 6 Q802 TO BE IN SAME BETA RANGE AS Q803  
 7 Q804 TO BE IN SAME BETA RANGE AS Q805  
 8 TRANSISTOR PAIR Q802-Q803 TO BE MATCHED TO PAIR Q804-Q805 WITHIN ONE BETA RANGE  
 9 TRANSISTOR PAIR Q806-Q807 TO BE MATCHED TO PAIR Q808-Q809 WITHIN ONE BETA RANGE  
 10 Q810 TO BE IN SAME BETA RANGE AS Q811 & Q812

Figure 21. Model 1200 Schematic, B



# ADDENDUM FOR MODEL 1200B

This manual is applicable to units bearing serial numbers above 5900 and is the same as the original manual except for the following.

Throughout the original manual, replace "A", "B", "Channel A", and "Channel B" with "L", "R", "L Channel" and "R Channel", respectively. Also, throughout the original manual, replace "Model 1200" with "Model 1200B",

Page 1 — Column 2, 3rd paragraph — Replace last sentence with: "This switch applies L, R, STEREO, STEREO REVERSE, or L+R signals to the BALANCE CONTROL through the GAIN SWITCH which selects HIGH or LOW overall preamplifier gain."

Page 4 — Column 1, 2nd paragraph — Replace entire paragraph with: "With the TONE CONTROL switch set to IN, the output of the tone amplifier is applied to the PREAMP OUT jacks."

Page 4 — Column 2, 2nd paragraph — Replace entire paragraph with: "With the TONE CONTROL switch set to OUT, the output of the X10 amplifier bypasses the tone amplifier and is applied directly to the PREAMP OUT jacks."

Pages 6 — Replace Figure 5 (Amplifier Simplified Schematic) and 7 with Figure 5 contained herein.

Page 8 — Replace entire circuit description section entitled "Amplifier" with circuit description contained herein.

Page 9 — Replace entire circuit description section entitled "Rectifier-Relay Board" with circuit description section entitled "Relay Board and Main Power Supply" contained herein.

Page 9 — Replace Figure 7 (Rectifier/Relay Board Simplified Schematic) with Figure 7 (Relay Board Simplified Schematic) contained herein.

Page 11 — TECHNICAL SPECIFICATIONS — For "Input Sensitivity and Impedance, Phono" replace "1.35mV, 47K ohms" with "1.35mV @ 1KHz, 47K ohms".

Page 11 — TECHNICAL SPECIFICATIONS — For "Input Sensitivity and Impedance, High Level" replace "135mV, 100K" with "135mV @ 1KHz, 25K ohms".

In "PERFORMANCE VERIFICATION TEST PROCEDURE", replace as indicated:

Page 13 — In paragraph C (Bias Adjustment Tests), sub-paragraph 4 — replace "10 watts" with "7 watts".

Page 14 — In paragraph C (Bias Adjustment Tests), sub-paragraph 5 — replace "10 watts" with "7 watts".

Page 14 — In paragraph E (Total Hum and Noise Test), sub-paragraph 4 — replace "36 millivolts" with "25 millivolts".

Page 14 — In paragraph G (Relay Operation), sub-paragraph 1 — replace "two minutes" with "thirty seconds".

Page 14 — In paragraph G (Relay Operation), sub-paragraph 4 — replace entire sub-paragraph with "Set audio oscillator for 5Hz. Switch load off. Slowly in-

crease output of oscillator until relay de-energizes. Distortion analyzer should indicate between 15 and 28 volts just prior to relay cutoff".

Page 14 — In paragraph H (Harmonic Distortion Test), sub-paragraph 1 — add "Set load to 8 ohms".

Page 17 — Replace Figure 10. (AC Power Control Box Simplified Schematic) with Figure 10. contained herein.

Page 17 — Replace Figure 11. (Amplifier Output Load Box Simplified Schematic) with Figure 11. contained herein.

In "TROUBLE ANALYSIS", replace as indicated:

Page 18 — In SYMPTOM 1. — Replace "(100 watts or more)" with "(80 watts or more)".

Page 18 — In SYMPTOM 1. PROCEDURE a. — Replace ". . . . CR701 through CR704 . . . ." with ". . . . CR1 through CR4 . . . .".

Page 18 — In SYMPTOM 1. PROCEDURE b. — Replace "Check for open control R526, 215-1005-1 bias assembly" with "Check for open bias circuit components; Q801, Q521, C513".

Page 18 — In SYMPTOM 2. PROCEDURE a. — Replace ". . . . 215-1005-1 bias assembly" with ". . . . bias circuit components; Q801, Q521, C513".

Page 18 — In SYMPTOM 2. PROCEDURE b. — Replace ". . . . CR701 through CR704 . . . ." with ". . . . CR1 through CR4 . . . .".

Page 18 — Replace SYMPTOM 3 with "Transient DC voltages at loudspeaker terminals before time delay circuit is deactivated".

Page 18 — In SYMPTOM 3. Add PROCEDURE b. — "Check for non-opening relay contacts".

Page 18 — In SYMPTOM 4. Add PROCEDURES b. through d. — "b. Check transistors Q503, Q504, Q507, Q508, Q510, Q511, Q516, and Q517". "c. Check for open DC Balance Control, R526". "d. Check capacitors C502, C503, and C504".

Page 18 — In SYMPTOM 5. Add PROCEDURE c. — "Check capacitors C502, C503, and C504".

Page 19 — In SYMPTOM 6. Add PROCEDURES b. and c. — "b. Check C4, C5, and T1 for leakage to chassis. Check C8 and C527 for short". "c. Check Preamp to Amp molded jumper plugs for open ground circuit. Check internal shielded wires for broken insulation allowing shields to short to chassis."

Page 19 — In SYMPTOM 7. PROCEDURE a. — Replace "Check for defective C506, C509, C516, and C505." with "Check for defective C505, C506, C508, C509, C510, C512, C516, C518, C519, C520, C524, C525, and C526". Add PROCEDURE b. — "Check for defective R511, R519, and R539".

Page 19 — In SYMPTOM 8. PROCEDURE b. — Replace "Check for transistors Q802 through Q805." with "Check transistors Q505, Q506, Q516, Q517, Q802 through Q805." Add PROCEDURE c — "Check for open CR1 through CR4."



Page 19 — In SYMPTOM 9. — Replace PROCEDURE b. with "Check output for proper clipping into 4 ohm load with 25.5 volts AC output (positive and negative levels must not vary more than 1 volt at 2 KHz)."

Page 19 — Add SYMPTOM 10. — "No Output". and add PROCEDURE a. — "Check R529, Q510, Q511, Q802 through Q805."

Pages 20 — PARTS LIST — Parts list contained herein identifies all parts which differ from those used in thru 25 units prior to serial number 3501.

Pages 26 — Replace Figure 13. (Interconnect Board — A1 and 27 Component Assembly Diagram) with Figure 13. contained herein.

Page 28 — Replace Figure 14. (Phono Amplifier Board — A2 Component Assembly Diagram) with Figure 14. contained herein.

Page 31 — Replace Figure 17. (Power Amplifier Board — A5/A6 Component Assembly Diagram) with Figure 17. contained herein.

Page 32 — Replace Figure 18. (Power Supply Board — A7 Component Assembly Diagram) with Figure 18. contained herein.

Page 33 — Replace Figure 19. (Rectifier/Relay Board — A8 Component Assembly Diagram) with Figure 19. (Relay Board — A8 Component Assembly Diagram) contained herein.

Pages 34 — Replace Figure 20. (Model 1200 Schematic, A) and 35 with Figure 20. (Model 1200B Schematic, A) contained herein.

Pages 36 — Replace Figure 21. (Model 1200 Schematic, B) and 37 with Figure 21. (Model 1200B Schematic, B) contained herein.

## CIRCUIT DESCRIPTION

### AMPLIFIER

The input of the power amplifier, Figure 5, is an RF filter comprised of R550 and C501, followed by transistors Q518 and Q519 which are coupled together as a conjugate paired amplifier with 100% feedback. The output of the conjugate pair is coupled through C502 and R506 to the differential amplifier, Q501-Q502, which drives a high gain inverter, Q503. Q504 is the current source for the inverter, and Q520 serves as a current source for the differential amplifier to enhance its common mode signal rejection. The inverter is coupled to complementary pre-drivers, Q507-Q508. The output of the pre-drivers is applied to the respective drivers, Q510-Q511, which feed their respective power transistors, Q802-Q804 and Q803-Q805.

Open loop phase and gain stabilization is provided by a Miller capacitor, C518, connected between the collector and base of the inverter (Q503). Further open loop stabilization is provided by Miller feedback at driver Q510 by C525 and R561, and at driver Q511 by C524 and R560.

Output current regulation is accomplished through a current-sensing network. Excessive current levels are detected by resistors R531 and R532. Voltages developed across these resistors are applied to current sensors Q516 and Q517. When excessive current levels are detected, Q516 and Q517 develop peak-limiting signals which are applied to Q505 and Q506, respectively. These transistors disable the pre-drivers on excessive output current peaks, thus limiting peak output current to the level determined by the adjustment of R541 and R542, respectively.

Feedback for the amplifier is developed at the junction of R531 and R532, and is applied across two loops. The driver power output loop is across R520 and C509. Feedback applied across R519 and C508 completes the loop for the entire power amplifier.

Idling current for the power transistors is controlled by transistors Q801 and Q521, and is adjusted by R526. Q521 is employed as a  $V_{be}$  multiplier with the collector current of Q801 determining the multiplication factor. The multiplied  $V_{be}$  voltage of Q521 appears across its collector and emitter. From there, it is applied as a biasing source to the drivers which are dc coupled to the power transistors. Transistor Q801 is mounted directly to the power transistor heatsink to assure close thermal tracking.

# PARTS LIST

Reference Designation	Description and/or Remarks	Marantz Part Number
A1	<b>Interconnection Board Component Assembly</b>	200-1037-100
C101	Cap., 520pf, $\pm 10\%$ , 100V	385-1069-000
C102	Cap., .15uf, $\pm 20\%$ , 250V	386-1022-000
C103	Cap., 520pf, $\pm 10\%$ , 100V	385-1069-000
C104	Cap., .15uf, $\pm 20\%$ , 250V	386-1022-000
R101	Res., C/F, 1K, $\pm 5\%$ , 1/4W	434-4102-000
R102	Res., C/F, 1K, $\pm 5\%$ , 1/4W	434-4102-000
R103	Res., Variable, Tandem, 25K	420-1023-000
R104	Res., Variable, Tandem, 50K	420-1048-000
R105	Res., C/F, 12K, $\pm 5\%$ , 1/4W	434-5122-000
R106	Res., C/F, 2.7K, $\pm 5\%$ , 1/2W	433-4272-000
R107	Res., C/F, 12K, $\pm 5\%$ , 1/4W	434-5122-000
R108	Res., C/F, 2.7K, $\pm 5\%$ , 1/2W	433-4272-000
R113	Res., C/F, 33K, $\pm 5\%$ , 1/4W	434-5332-000
R114	Res., C/F, 33K, $\pm 5\%$ , 1/4W	434-5332-000
S101	Switch, Mode	453-1035-000
S102	Switch, Tone	453-1036-000
S103	Switch, Lo Filter	453-1037-000
S104	Switch, Hi Filter	453-1037-000
	Connector Block, 16 Pin	360-1019-000
	Connector Block, 13 Pin	360-1020-000
	Connector Block, 12 Pin	360-1021-000
	Insulator, Light Shield	127-1059-000
A2	<b>Phono Amplifier Board Component Assembly</b>	200-1033-100
C203	Cap., 1.0uf, $\pm 10\%$ , 250V	386-1034-000
C211	Cap., 1.0uf, $\pm 10\%$ , 250V	386-1034-000
C215	Cap., 1.0uf, $\pm 10\%$ , 250V	386-1034-000
C224	Cap., 1.0uf, $\pm 10\%$ , 250V	386-1034-000
R214	Res., Variable, 25K, 1/4W	420-1024-000
R222	Res., C/F, 2.2M, $\pm 10\%$ , 1/4W	434-7223-000
R235	Res., Variable, 25K, 1/4W	420-1024-000
Q201	Transistor, NPN	462-1038-110
Q202	Transistor, NPN	462-1038-110
Q205	Transistor, NPN	462-1038-110
Q206	Transistor, NPN	462-1038-110
A3	<b>X10 Board Component Assembly</b>	200-1022-100
C402	Cap., 1.0uf, $\pm 10\%$ , 100V	386-1018-000
C403	Cap., Elect. 1.0uf, 35V	381-1055-000
C407	Cap., Elect. 1.0uf, 35V	381-1055-000
C413	Cap., 1.0uf, $\pm 10\%$ , 100V	386-1018-000
C414	Cap., Elect. 1.0uf, 35V	381-1055-000
C417	Cap., Elect. 1.0uf, 35V	381-1055-000
Q401	Transistor, NPN	462-1038-210
Q402	Transistor, NPN	462-1038-210
Q404	Transistor, NPN	462-1038-210
Q405	Transistor, NPN	462-1038-210
A4	<b>Tone Amplifier Board Component Assembly</b>	200-1023-000
C301	Cap., 1.0uf, $\pm 10\%$ , 100V	386-1018-000
C309	Cap., 1.0uf, $\pm 10\%$ , 250V	386-1034-000
C311	Cap., 1.0uf, $\pm 10\%$ , 100V	386-1018-000
C318	Cap., 1.0uf, $\pm 10\%$ , 250V	386-1034-000
R307	(not used)	(not used)
R312	Res., C/F, 56 ohm, $\pm 5\%$ , 1/4W	434-2562-000
R322	(not used)	(not used)

Reference Designation	Description and/or Remarks	Marantz Part Number
Q301	Transistor, NPN	462-1038-210
Q302	Transistor, NPN	462-1038-210
Q304	Transistor, NPN	462-1038-210
Q305	Transistor, NPN	462-1038-210
A5, A6	<b>Heatsink Assembly</b>	215-1012-200
	<b>Amplifier Board Component Assembly</b>	200-1071-200
C502	Cap., Elect. 10uf, 20V	381-1068-000
C503	Cap., Elect., 10uf, 20V	381-1068-000
C504	Cap., Elect., 10uf, 20V	381-1068-000
C505	Cap., 36pf, $\pm 5\%$ , 100V	385-1064-000
C506	(not used)	(not used)
C508	Cap., 47pf, $\pm 10\%$ , 100V	385-1040-000
C512	Cap., 1000pf, $\pm 10\%$ , 100V	385-1068-000
C518	Cap., 5pf, $\pm 10\%$ , 100V	385-1049-000
C519	Cap., 0.1uf, $\pm 10\%$ , 250V	386-1000-000
C520	Cap., 6800pf, $\pm 10\%$ , 400V	386-1026-000
C522	Cap., 47pf, $\pm 10\%$ , 100V	385-1040-000
C523	Cap., 27pf, $\pm 10\%$ , 100V	385-1036-000
C524	Cap., 270pf, $\pm 10\%$ , 300V	385-1090-000
C525	Cap., 270pf, $\pm 10\%$ , 300V	385-1090-000
C526	Cap., 0.1uf, $\pm 10\%$ , 250V	386-1000-000
C527	Cap., Elect., 100uf, 3V	381-1089-000
L501	Toroid	147-1009-000
R501	Res., C/F, 4.7K, $\pm 5\%$ , 1/4W	434-4472-000
R502	Res., Variable, 2K, 2W	420-1045-000
R503	Res., C/F, 4.7K, $\pm 5\%$ , 1/4W	434-4472-000
R508	Res., C/F, 39K, $\pm 5\%$ , 1/4W	434-5392-000
R509	Res., C/F, 4.7K, $\pm 5\%$ , 1/4W	434-4472-000
R511	Res., C/F, 1.8K, $\pm 5\%$ , 1/4W	434-4182-000
R512	Res., C/F, 7.5K, $\pm 5\%$ , 1/4W	434-4752-000
R515	Res., C/F, 27 ohm, $\pm 5\%$ , 1/4W	434-2272-000
R517	Res., M/F, 1.3K, $\pm 5\%$ , 3W	439-1022-000
R518	Res., M/F, 1.3K, $\pm 5\%$ , 3W	439-1022-000
R522	Res., C/F, 560 ohm, $\pm 5\%$ , 1/4W	434-3562-000
R523	Res., C/F, 560 ohm, $\pm 5\%$ , 1/4W	434-3562-000
R524	Res., C/F, 24K, $\pm 5\%$ , 1/4W	434-5242-000
R525	Res., C/F, 24K, $\pm 5\%$ , 1/4W	434-5242-000
R526	Res., Variable, 100 ohm, 2W	420-1044-000
R527	Res., C/F, 47 ohm, $\pm 5\%$ , 1/4W	434-2472-000
R528	Res., C/F, 47 ohm, $\pm 5\%$ , 1/4W	434-2472-000
R529	Res., M/F, 39 ohm, $\pm 5\%$ , 1W	439-1023-000
R530	Res., M/F, 39 ohm, $\pm 5\%$ , 1W	439-1023-000
R539	Res., M/F, 27 ohm, $\pm 5\%$ , 2W	439-1021-000
R540	Res., C/F, 2.2K, $\pm 5\%$ , 1/4W	434-4222-000
R541	Res., Variable, 2.5K, 1/4W	420-1046-000
R542	Res., Variable, 2.5K, 1/4W	420-1046-000
R543	Res., C/F, 2.2K, $\pm 5\%$ , 1/4W	434-4222-000
R544	Res., C/F, 1K, $\pm 5\%$ , 1/4W	434-4102-000
R545	Res., C/F, 1K, $\pm 5\%$ , 1/4W	434-4102-000
R547	Res., C/F, 20K, $\pm 5\%$ , 1/4W	434-5202-000
R548	Res., C/F, 270 ohm, $\pm 5\%$ , 1/4W	434-3272-000
R549	Res., C/F, 5.6K, $\pm 5\%$ , 1/4W	434-4562-000
R552	Res., C/C, 5.6 ohm, $\pm 5\%$ , 1W	423-1562-000
R553	Res., C/C, 5.6 ohm, $\pm 5\%$ , 1W	423-1562-000
R554	Res., C/F, 56K, $\pm 5\%$ , 1/4W	434-5562-000
R555	Res., C/F, 22K, $\pm 5\%$ , 1/4W	434-5222-000
R556	Res., C/F, 360 ohm, $\pm 5\%$ , 1/4W	434-3362-000
R557	Res., C/F, 10 ohm, $\pm 5\%$ , 1/4W	434-2102-000
R558	Res., C/F, 560 ohm, $\pm 5\%$ , 1/4W	434-3562-000
R559	Res., C/F, 470 ohm, $\pm 5\%$ , 1/4W	434-3472-000
R560	Res., C/F, 10 ohm, $\pm 5\%$ , 1/4W	434-2102-000
R561	Res., C/F, 10 ohm, $\pm 5\%$ , 1/4W	434-2102-000
R562	Res., C/F, 10 ohm, $\pm 5\%$ , 1/4W	434-2102-000

Reference Designation	Description and/or Remarks	Marantz Part Number
Q501	Transistor, NPN	462-1066-010
Q502	Transistor, NPN	462-1066-010
Q503	Transistor, PNP	461-1054-010
Q507	Transistor, PNP	* 461-1056-000
Q508	Transistor, NPN	* 462-1053-000
Q510	Transistor, NPN	* 462-1054-000
Q511	Transistor, PNP	* 461-1046-000
Q516	Transistor, NPN	462-1058-010
Q517	Transistor, PNP	461-1050-010
Q518	Transistor, PNP	461-1055-010
Q519	Transistor, NPN	462-1038-210
Q520	Transistor, NPN	462-1042-000
Q521	Transistor, PNP	461-1055-010
	Thermal Retainer (TO-92 Pr)	562-1007-000
	Heat Dissipator (TO-5)	562-1000-000
	Transistor Insulator (TO-5)	372-1000-000
	Transistor Insulator (TO-66)	371-1007-000
	Nylon Washer	676-1006-000
	Nylon Shoulder Washer	676-1008-000
	Toroid Retainer	570-1003-000
C801		(not used)
CR801		(not used)
Q801	Transistor, NPN (includes mtg washer and insulator)	462-1067-010
	Heat Sensor Assy	(not used)
	Wire & Socket Assy	157-1011-100
Q802	Transistor, PNP	* 461-1031-010
Q803	Transistor, NPN	* 462-1036-010
Q804	Transistor, PNP	* 461-1031-010
Q805	Transistor, NPN	* 462-1036-010
A7	<b>Power Supply Board Component Assembly</b>	200-1025-500
Q601	Transistor, NPN	462-1055-000
Q602	Transistor, PNP	461-1048-000
A8	<b>Relay Board Component Assembly</b>	200-1075-100
CR701		(not used)
CR702		(not used)
CR703		(not used)
CR704		(not used)
R709		(not used)
R710		(not used)
R711	Res., W/W, 300 ohm, $\pm 10\%$ 5W	428-3303-000
	<b>Chassis Assembly</b>	
C8	Cap., Elect., 100uf, 3V	381-1090-000
CR1	Diode, Rectifier	460-1014-000
CR2	Diode, Rectifier	460-1014-000
CR3	Diode, Rectifier	460-1014-000
CR4	Diode, Rectifier	460-1014-000
DS1	Lamp, Pilot	482-1001-000
J4	Phone Jack, Dubbing In	360-1004-000
J5	Phone Jack, Dubbing Out	360-1005-000
J6	Phone Jack, Stereophones	360-1005-000
J7	Tape Recorder Jack, DIN	360-1016-000
J8, J19	Phone Jack, Mic	360-1017-000

Reference Designation	Description and/or Remarks	Marantz Part Number
R1	Res., C/F, 130K, $\pm 5\%$ , 1/2W	433-6132-000
R2	Res., C/F, 130K, $\pm 5\%$ , 1/2W	433-6132-000
R3	Res., C/F, 130K, $\pm 5\%$ , 1/2W	433-6132-000
R4	Res., C/F, 130K, $\pm 5\%$ , 1/2W	433-6132-000
R5		(not used)
R6		(not used)
R7		(not used)
R8		(not used)
R9	Res., C/F, 27 ohm, $\pm 5\%$ , 1/2W	433-2272-000
R10		(not used)
R13	Res., W/W, 2.2K, $\pm 5\%$ , 2W	436-4222-000
R14	Res., W/W, 2.2K, $\pm 5\%$ , 2W	436-4222-000
S1	Switch, Selector	453-1018-000
S3	Switch, Slide	452-1019-000
S4	Switch, Power	452-1016-000
S5	Switch, Speaker	453-1034-000
T1	Transformer, Power	440-1011-150
	<b>Miscellaneous Parts</b>	
	Rear Panel Circuit Board	200-1036-100
	Diode Mounting Board Assy	201-1005-100
	Knob, Large	174-1001-000
	Knob, Medium	174-1002-000
	Knob, P/B Switch	174-1004-000
	Panel, Front Dress	134-1032-200
	Cover, Top	136-1003-000
	Cover, Transistor	136-1017-000
	Lens, Light	170-1002-000
	Connector, Molded	360-1027-000
	Shield, Lamp	483-1000-000
	Binding Post, Chassis Grd.	359-1004-000
	Jack, Center Channel	360-1030-000
	Insulator, Ctr Chan Jack	370-1005-000

\*For beta range matching requirements, see transistor specification chart on unit schematic (Figure 21).

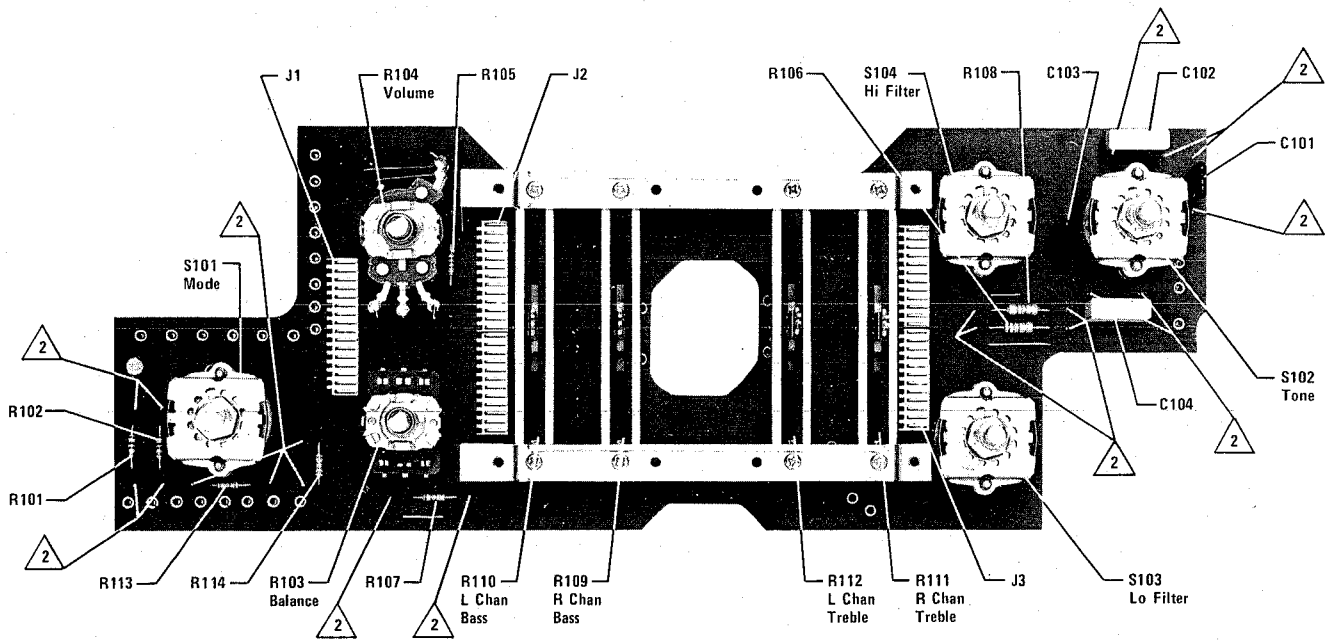

COMPONENT SIDE

Notes:

1. Configuration shown is applicable to circuit boards fabricated using A/W 115-1037, Rev C.
2. Components (other than controls) may be replaced by installing replacement component on circuit side of board using auxilliary holes indicated and cutting circuitry to existing component.
3. Care must be exercised when replacing controls to ensure that mounting plane of controls is flat over length and width of board.

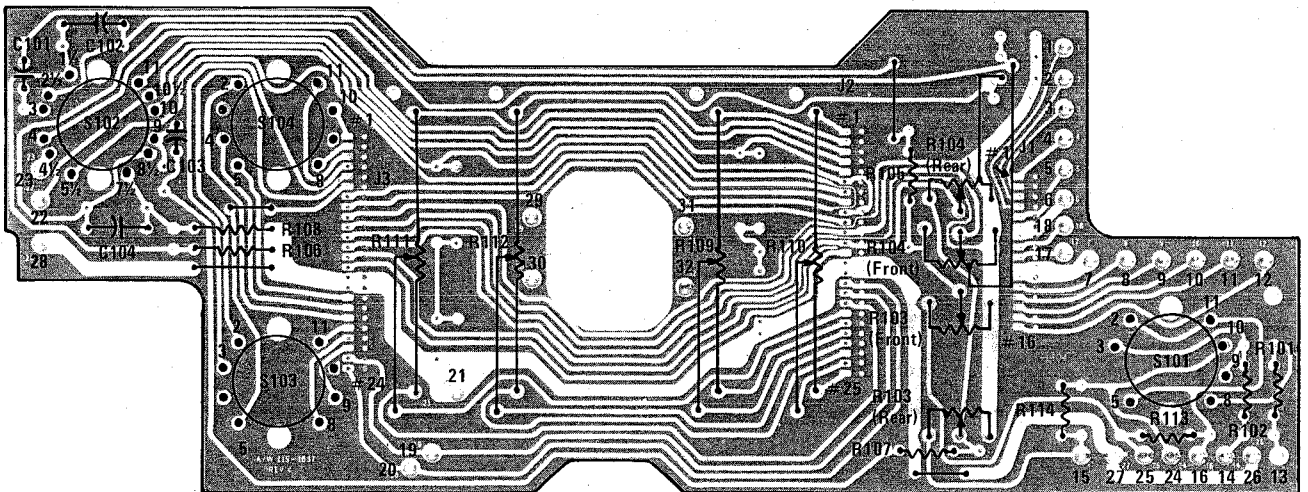

CIRCUIT SIDE

Figure 13. Interconnect Board – A1 Component Assembly Diagram

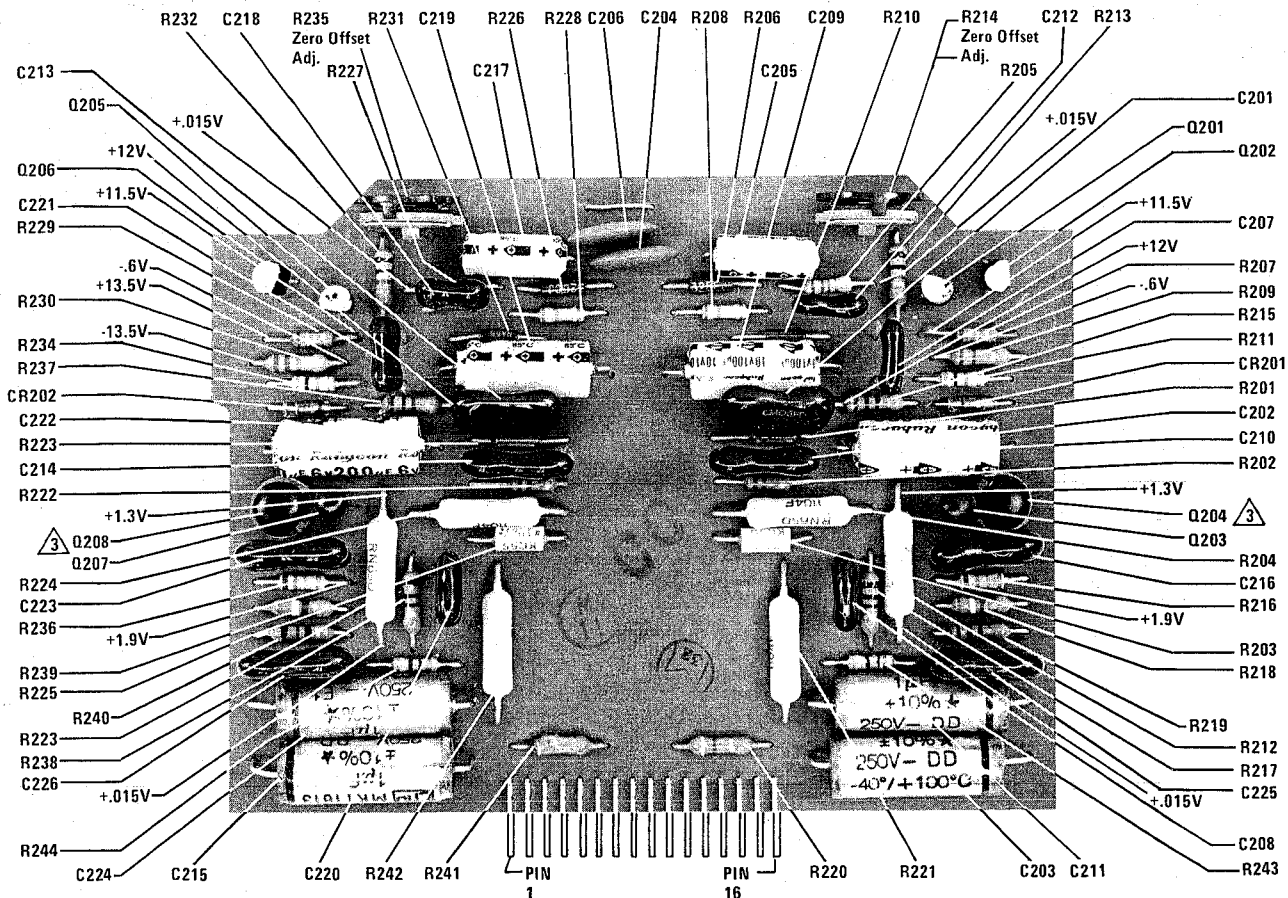

**COMPONENT SIDE**

**Notes:**

1. Voltages are d-c volts to ground, measured on a typical unit.
2. Configuration shown is applicable to circuit boards fabricated from A/W 115-1033, Rev N/C.
3. P/N 372-1000-000 Insulator to be installed under Q204 and Q208.

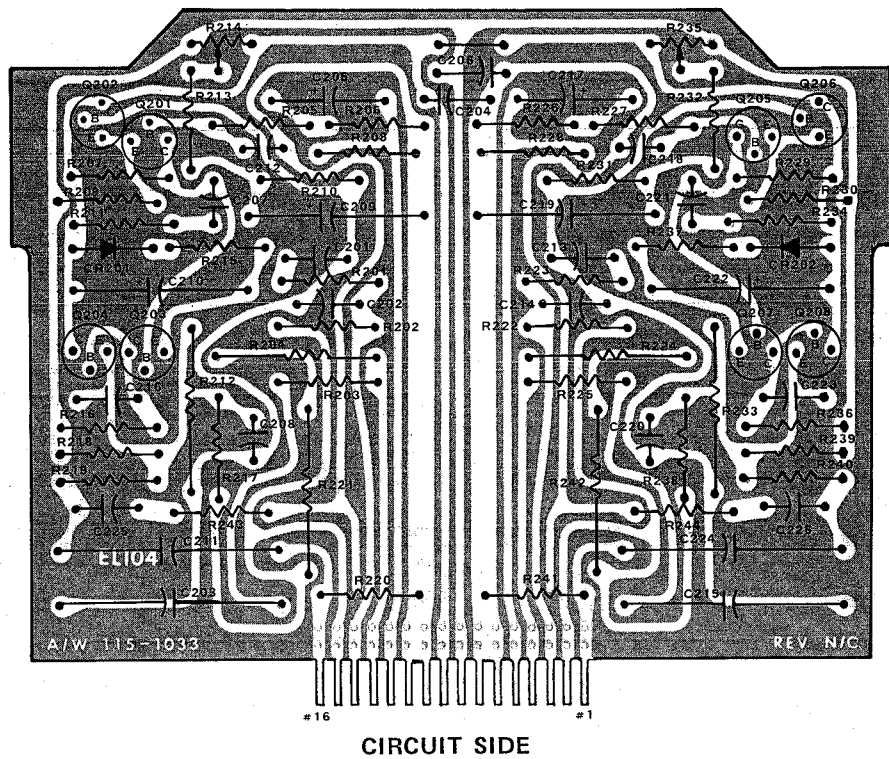

**CIRCUIT SIDE**

**Figure 14. Phono Amplifier Board – A2 Component Assembly Diagram**