

# NEOPHYTE 1

**M**any newcomers to experimental electronics never get off the ground because of one or both of these reasons: their first project is too involved and difficult to adjust for proper operation; or the project is extremely simple and the results not rewarding enough to sustain sufficient interest to pursue other projects.

With these facts in mind, we present Neophyte 1 which will work for any beginner who can read schematic diagrams and follow simple instructions. No involved adjustment or alignment is required to hear shortwave stations from all over the world on this one-tube radio.

**What's With It.** Neophyte 1 may be broken down into two stages—a regenera-

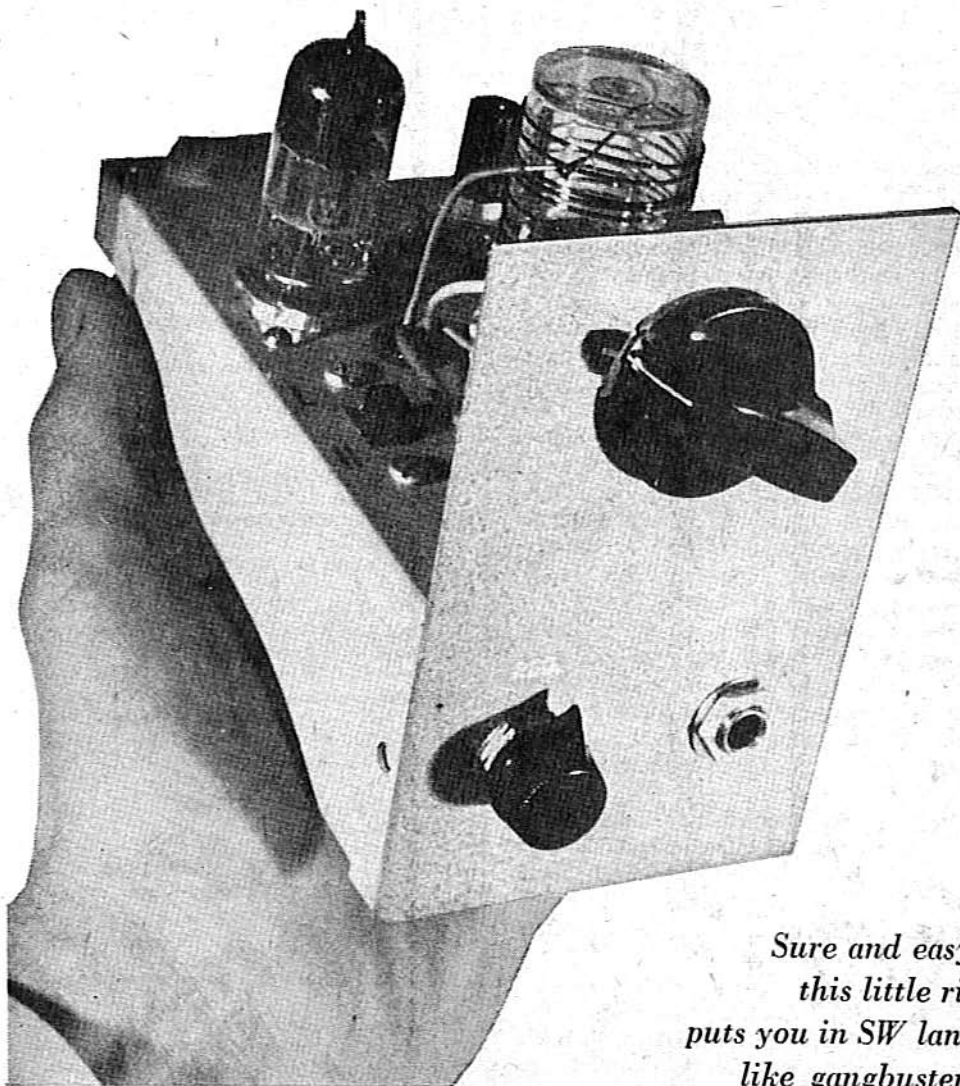

*Sure and easy,  
this little rig  
puts you in SW land  
like gangbusters*

*Schematic of Neophyte I shows conventional regenerative detector circuit followed by a stage of audio. Note how band is changed simply by switching capacitor C2 in and out of tuning circuit.*

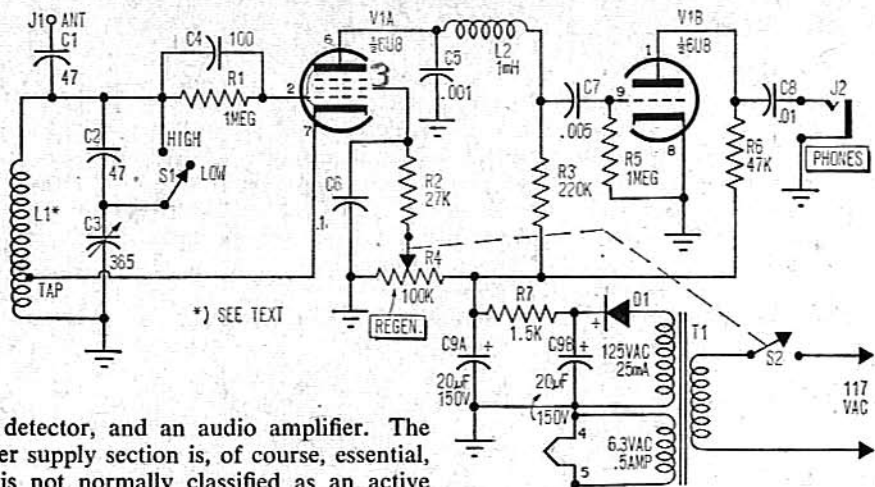

tive detector, and an audio amplifier. The power supply section is, of course, essential, but is not normally classified as an active stage.

The circuits are traditional. A regenerative-type detector, although no longer in use in commercial equipment, still finds plenty of applications where budget-minded experimenters and space requirements are involved.

The detector, besides extracting the audio from the carrier signal, also provides a considerable amount of audio amplification. It would certainly take more than half of one tube to do this using other conventional circuits.

The amplified signal from the detector is coupled to the audio amplifier stage where its level is increased still further to operate a pair of standard high-impedance headphones with adequate volume.

**Wherewithal.** Starting at the antenna jack in the schematic, you will notice a 47-pF capacitor (C1) connected between it and the tuned circuit. This capacitor prevents antenna loading effects and results in smoother operation of the regenerative feedback circuit.

The tuned circuit consists of coil L1, tuning capacitor C3 and a fixed capacitor, C2. The single-pole-single-throw switch S1 shorts out C2 when closed and places C2 in series with the variable tuning capacitor C3 when it's open.

The closed position places more capacitance in the circuit and therefore tunes the receiver to a low frequency shortwave band. When the switch is open, total capacitance is less than 47 pF maximum (the value of

#### PARTS LIST

- C1, C2—47-pF disc ceramic capacitor
- C3—10 to 365- or 10 to 410-pF variable capacitor
- C4—100-pF disc ceramic capacitor
- C5—.001-μF disc ceramic capacitor
- C6—0.1-μF capacitor
- C7—.005-μF disc ceramic capacitor
- C8—.01-μF disc ceramic capacitor
- C9A, C9B—20-20-μF 150-VDC dual section electrolytic capacitor (Radio Shack 272-105 or equiv.)
- D1—400-piv., 200-ma or better silicon rectifier diode (Radio Shack 276-1126 or equiv.)
- J1—Insulated binding post (Radio Shack 274-736 or equiv.)
- J2—Headphone jack (Radio Shack 274-293 or equiv.)
- L1—Wound from #22 AWG enamel covered copper wire (see text)
- L2—1-mH radio frequency choke
- R1, R5—1,000,000-ohm, ½-watt resistor
- R2—27,000-ohm, ½-watt resistor
- R3—220,000-ohm, ½-watt resistor
- R4—100,000-ohm linear taper potentiometer with s.p.s.t. switch S2
- R6—47,000-ohm, ½-watt resistor
- R7—1500-ohm, 1-watt resistor
- S1—S.p.s.t. slide switch
- S2—Mounted on R4
- T1—Power transformer: 117-VAC pri., 125-VAC, 25-mA; 6.3-VAC, 0.3-A sec.
- V1A, V1B—6U8A vacuum tube
- 1—5¼ x 3 x 2½-in. aluminum minibox (Radio Shack 77-0683 or equiv.)
- 1—High impedance (2000-ohm or more) headphones
- Misc.—9-pin tube socket, scrap aluminum for front panel, knobs, grommets, line cord and plug, terminal strips, screws and nuts, etc.

301178-16-93 NICE!

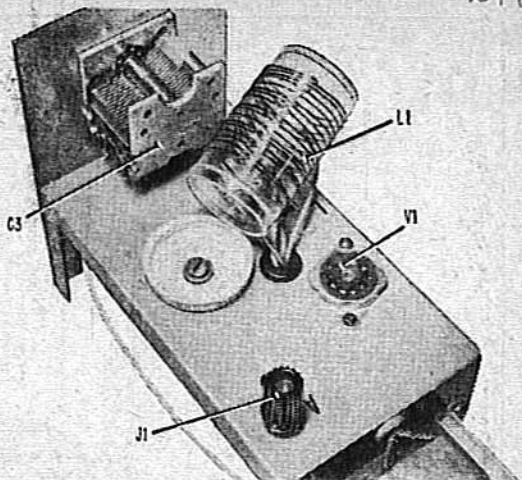
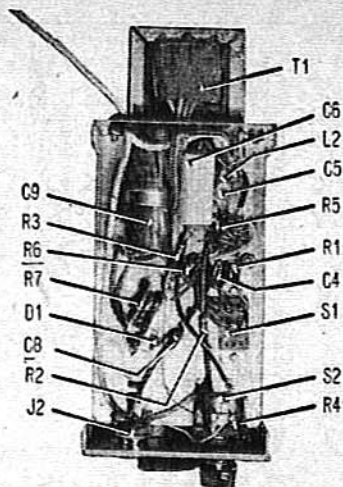

At left, parts arrangement in Neophyte is compact but uncluttered. Coil at right is wound on plastic pill bottle as shown.

C2) and this provides a second, higher frequency shortwave band. Using the specifications given for the coil and the capacitor values, Neophyte 1 covers from about 3 to 7 MHz on the low band, and from about 9 to 12 MHz on the high band. Other frequencies, higher or lower, may be covered by changing the value of C2 and the number of turns in L1. If you use variations, experimentation with the "tap" may be necessary.

**Audio Extraction.** As mentioned before, the first, or pentode section, of the dual section tube extracts the audio from the received signal and passes it to the triode audio amplifier stage. However, plenty of unwanted radio frequency signals also appear

at the plate of the pentode section and they must be dispensed with for proper operation. The radio frequency choke L2 and bypass capacitor C5 are placed in the circuit for this purpose. The choke blocks or "chokes" higher frequencies, but allows lower audio frequencies to pass; conversely, the bypass capacitor blocks low frequencies and bypasses unwanted RF to ground. The result is a relatively clean audio signal appearing between the grid and cathode of the audio section for additional amplification.

**Regeneration.** The current in the detector stage must flow through the lower portion of coil L1 and up to the cathode where it divides between the plate and the screen grid. The screen grid is connected to the positive (B+) supply through a limiting resistor and potentiometer R4. By changing the resistance of the pot, the screen voltage is varied and the tube current changes. The pot thereby varies the current through the tapped portion of the coil. The degree of current flow determines the amount of signal that is coupled to the upper portion of the coil which, in turn, determines the amount of feedback. The potentiometer is called a regeneration control, and it, as its name implies, controls the regeneration or feedback of the signal voltage.

**Building Neophyte I.** All parts mount on or in a 5¼ x 3 x 2½-in. aluminum mini-box. A small piece of scrap aluminum measuring 3 x 4½-in. is used for the front panel. Follow the photos to locate mounting positions.

(Continued on page 104)

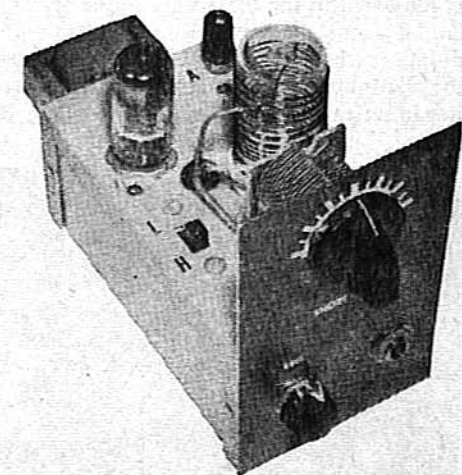

Neophyte 1 will provide many hours of entertainment receiving the most active shortwave bands.

## Neophyte I

Continued from page 77

Start by cutting the large holes first, and finish up with all the small holes using the parts themselves for templates. The panel is secured to the box by the phone jack and regeneration control mounting hardware.

The power transformer T1 is mounted on the rear of the minibox. Two holes are made to pass the transformer leads inside the box for wiring. Make sure that all holes and mounting plans are such that the other half of the chassis box will fit in place without obstruction.

**Cool Coil.** A 1 x 2-in. long plastic pill vial is put to use as a coil form. The plastic cap of the vial serves as the coil form "socket" and is mounted on the chassis with a nut and bolt.

The coil consists of 17 turns of #22 AWG enamel-covered copper magnet wire. A tap is made 4 turns from the bottom or ground end of the coil.

The turns of the coil are spaced to cover approximately 1 1/4 inches. The #22 wire is stiff enough to be self-holding and cement is not needed. Minor frequency adjustments may be made later by adjusting the spacing between the turns.

Hookup wire brought through a grommet-protected hole in the minibox connects the coil to the proper circuit points. The band switch S1 is mounted on the top of the minibox, but a layout variation on the front panel will allow enough mounting space there.

When all components are wired in the circuit, make a careful check to insure that no short circuits exist and that there is proper clearance for the bottom of the chassis box.

**Fire It Up.** Turn Neophyte 1 on and check that the tube lights. Then make sure nothing is smoking or overheating. Connect an antenna to the jack and advance the regeneration control to a point just before the set breaks into oscillation. Turn the band switch to the high band and tune for a station. Readjust the regeneration control for best reception. Receiving conditions will be best after dark so don't be discouraged if you turn the little Hertz-grabber on during daylight hours and don't find much action. Try various inside antenna lengths and use the best one. A high outside antenna will be best for long-distance reception. ■

## Scrooge Special

Continued from page 70

### PARTS LIST

- J1—RF connector, single hole mounting, type 50-2395H (Lafayette 42H6907 or equiv.)  
R1, R2, R3, R4—50-ohm, 100-watt, 1% non-inductive resistors (Corning Glass R-35\* or equiv.)  
1—5x4x3-in. aluminum chassis box (Lafayette 12H8389 or equiv.)  
4—Rubber feet, 3/8-in. dia. (Lafayette 13H6035 or equiv.)  
1—Equipment handle (Allied Radio 42E8078 or equiv.)  
Misc.—Wire, solder, perforated aluminum, nuts, bolts, spray paint, insulated terminal lug, etc.  
\* Available from John Mesha, Jr. Surplus, 19 Allerton St., Lynn, Mass. 01904

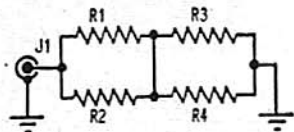

Wire resistors together as shown in schematic, then install in chassis box.

ground lug, and the insulated terminal post as shown in the photo.

**Finishing Up.** Carefully note the physical placement of the load resistors R1 through R4. These resistors are supported by the connecting wires to connector J1 and the ground lug on one side of the case, and to the insulated terminal lug on the other side. The sole purpose of the insulated terminal lug is to support the load resistors, no other wires or components are connected to it.

To speed construction, first wire the load resistors together per the schematic. After

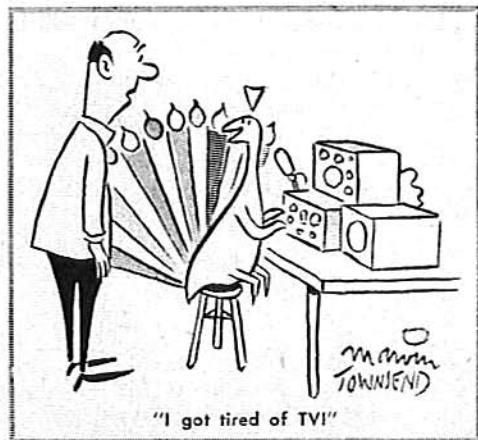

"I got tired of TV!"