

McIntosh

MA 6100

PREAMP AMPLIFIER



SERVICE INFORMATION

STARTING WITH SERIAL NO. AE1001

PERFORMANCE

McIntosh audio power ratings are in accordance with the Federal Trade Commission Regulation of November 4, 1974 concerning power output claims for amplifiers used in home entertainment products.

POWER OUTPUT

70 watts minimum sine wave continuous average power output, per channel, both channels operating into 8 ohms load impedance which is:

23.7 volts RMS across 8 ohms

40 watts minimum sine wave continuous average power output, per channel, both channels operating into 16 ohms load impedance which is:

25.3 volts RMS across 16 ohms

OUTPUT LOAD IMPEDANCE

8 ohms or 16 ohms

RATED POWER BAND

20 Hz to 20,000 Hz

TOTAL HARMONIC DISTORTION

0.2% maximum harmonic distortion at any power level from 250 milliwatts to rated power per channel from 20 Hz to 20,000 Hz, both channels operating

INTERMODULATION DISTORTION

0.2% if instantaneous peak power output is twice rated continuous average power or less per channel with both channels operating for any combination of frequencies 20 Hz to 20,000 Hz

FREQUENCY RESPONSE

20 Hz to 20,000 Hz +0 -0.5 dB at rated power

NOISE AND HUM

Power amplifier: 95 dB below rated output
Aux, Tape, Tuner: 90 dB below rated output
Phono Input, Tape Hd.: 76 dB below 10 mV input

RATINGS**OUTPUT VOLTAGE**

At TAPE output: Aux, Tape, Tuner: 300 mV with input
Phono: 300 mV with rated input;
1.2 volts with 1.0 mV input at 1000 Hz
Tape Hd: 300 mV at 500 Hz with rated input

DAMPING FACTOR

50 at 8 ohms output
100 at 16 ohms output

INPUT SENSITIVITY AND IMPEDANCE

Power Amplifier: 3 volts, 100,000 ohms
Phono 1 and Phono 2: 2.5 mV at 1000 Hz, 47,000 ohms
Tape Head: 3 mV, 47,000 ohms
Tape, Aux, and Tuner: 300 mV, 250,000 ohms

BASS CONTROLS

+16 dB to -16 dB at 20 Hz

TREBLE CONTROLS

+16 dB to -16 dB at 20,000 Hz

LF FILTER

Active filter, 12 dB per octave rolloff below 50 Hz;
20 dB down at 20 Hz

HF FILTER

Active filter, 12 dB per octave rolloff above 7000 Hz;
20 dB down at 20,000 Hz

GENERAL INFORMATION**SEMICONDUCTOR COMPLEMENT**

36 Silicon Transistors, 22 Silicon Rectifiers and Diodes, 2 Silicon Bilateral Switches, 2 Triac

POWER REQUIREMENTS

120 Volts, 50/60 Hz, 50 watts at zero signal output,
380 watts at rated output

MECHANICAL INFORMATION**SIZE**

Front panel measures 16 inches wide (40.64 cm) by 5 7/16 inches high (13.81 cm). Chassis measures 15 inches wide (38.1 cm) by 13 inches deep (33.02 cm), including Panloc shelf and back panel connectors. Knob clearance required is 1½ (3.81 cm) in front of mounting panel

WEIGHT

34 pounds (15.42 kg) net, 46 pounds (20.87 kg) in shipping carton

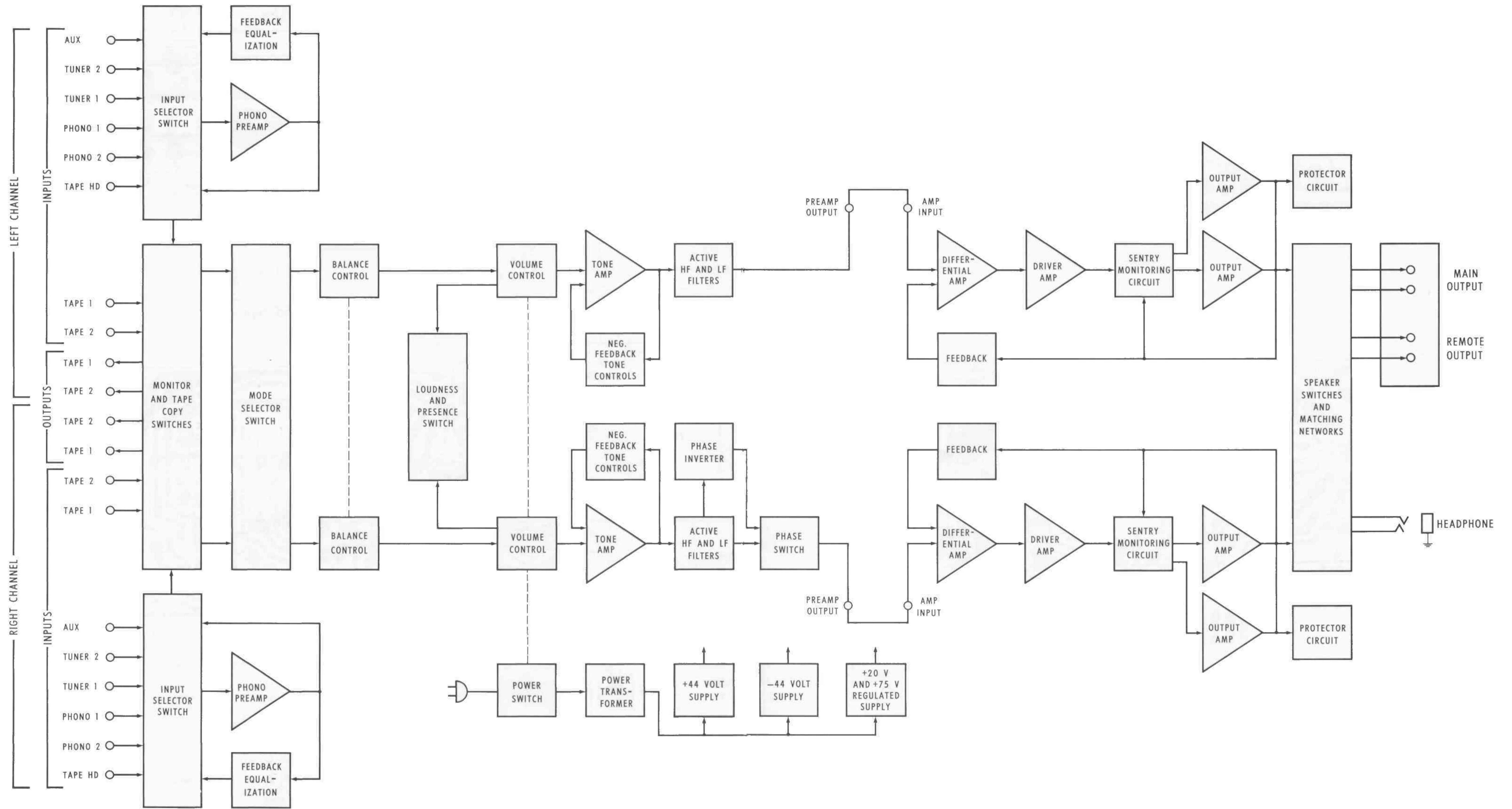

MA6100 BLOCK DIAGRAM

TONE & VOLUME CONTROL PC BOARD 044-514

NOTE 10

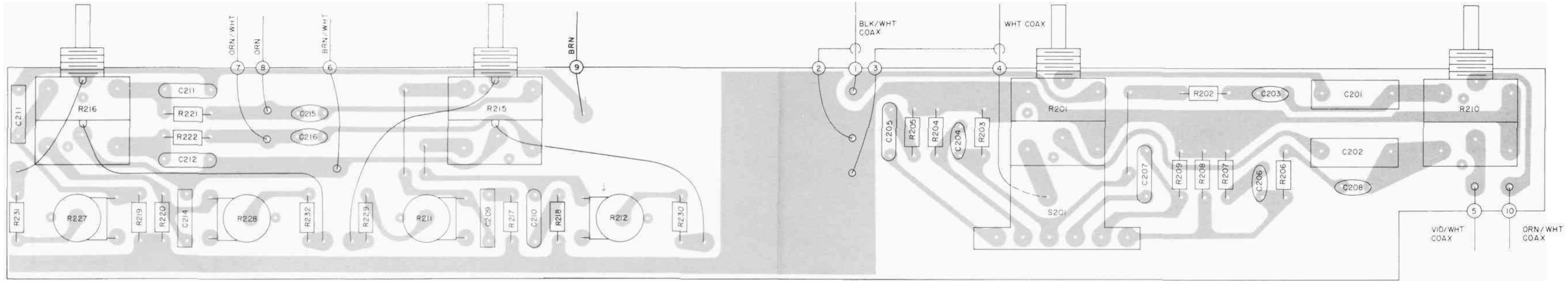

LEFT CHANNEL PREAMP PC BOARD 044-512

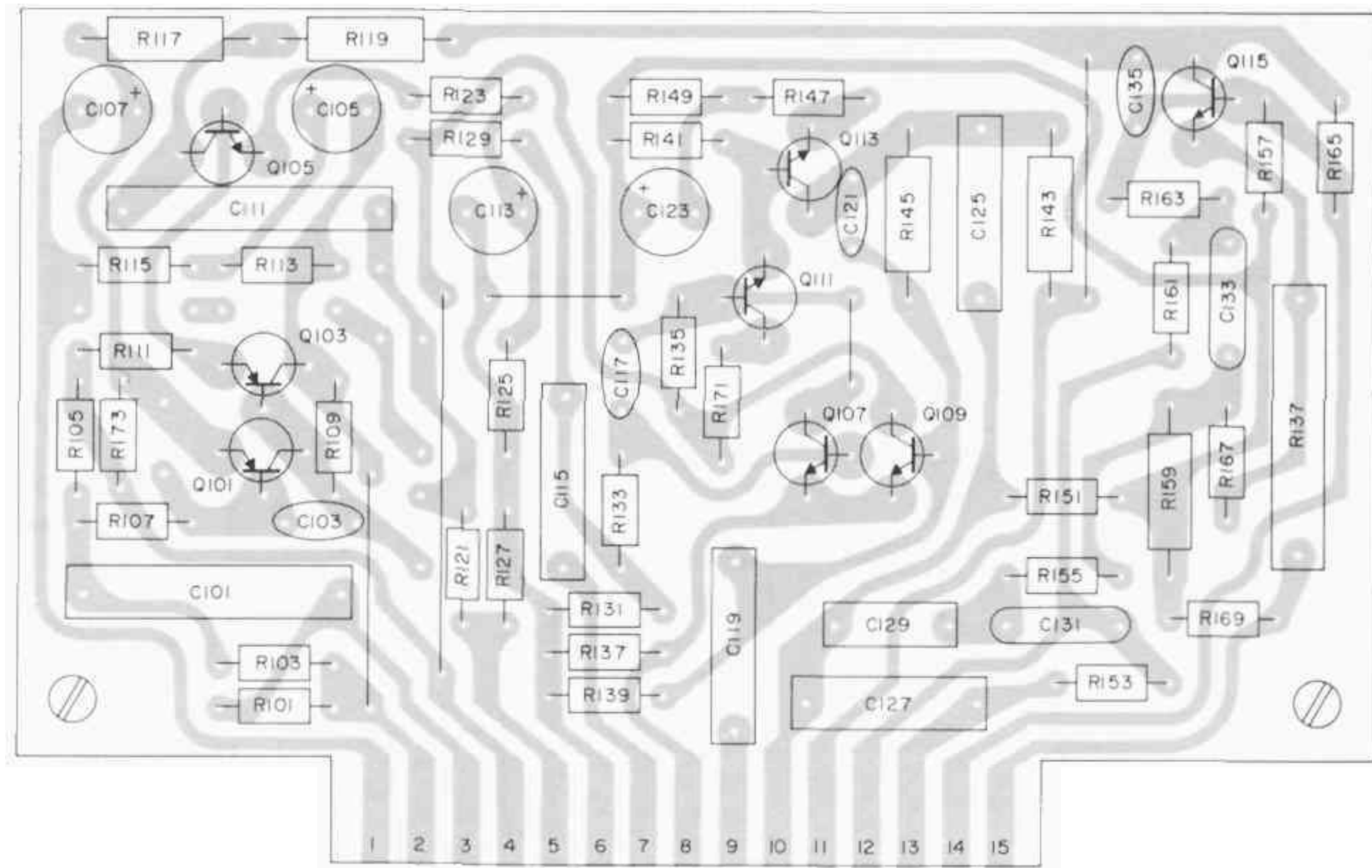

RIGHT CHANNEL PREAMP PC BOARD 044-512

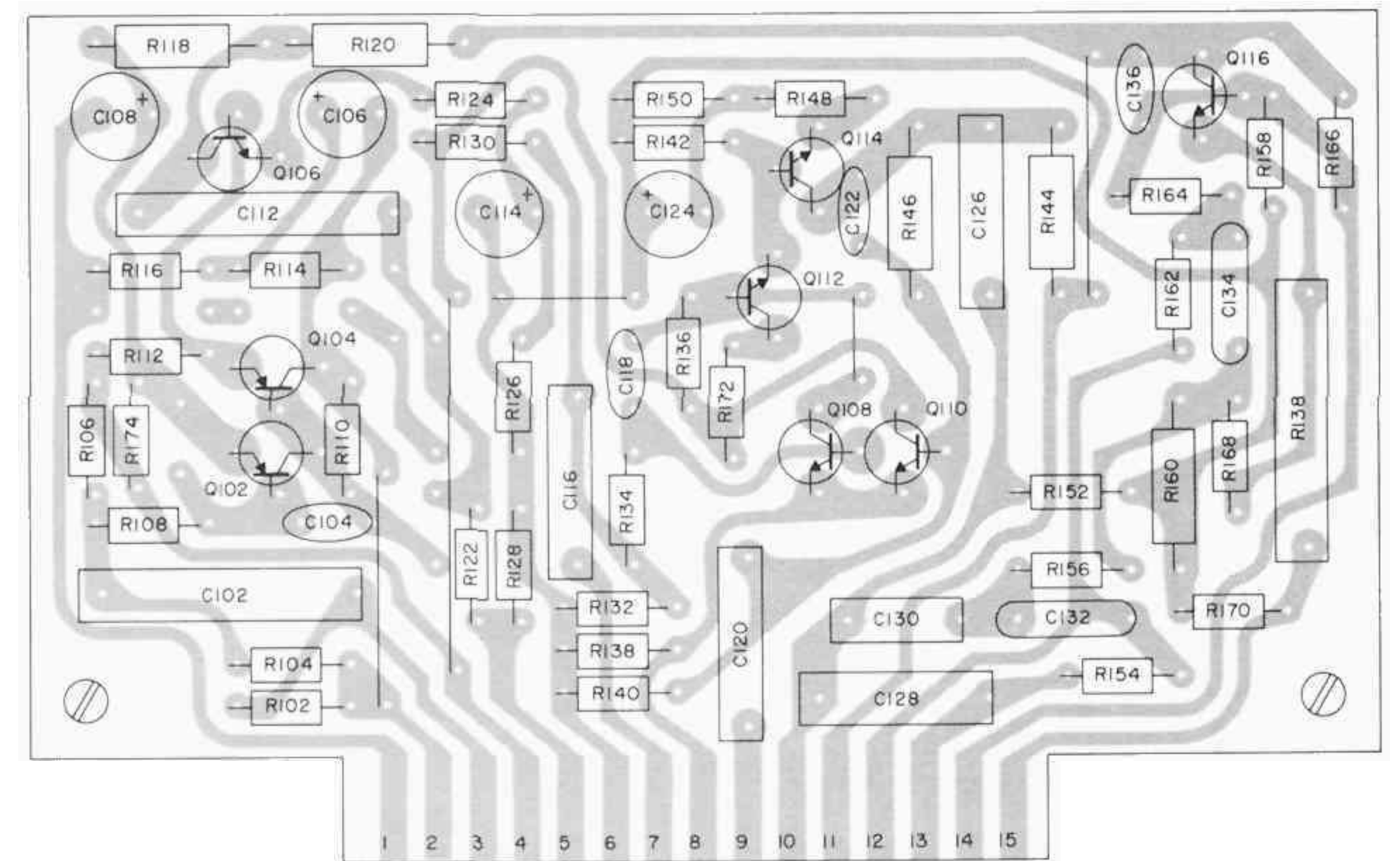

EQUALIZATION PC BOARD 044-420

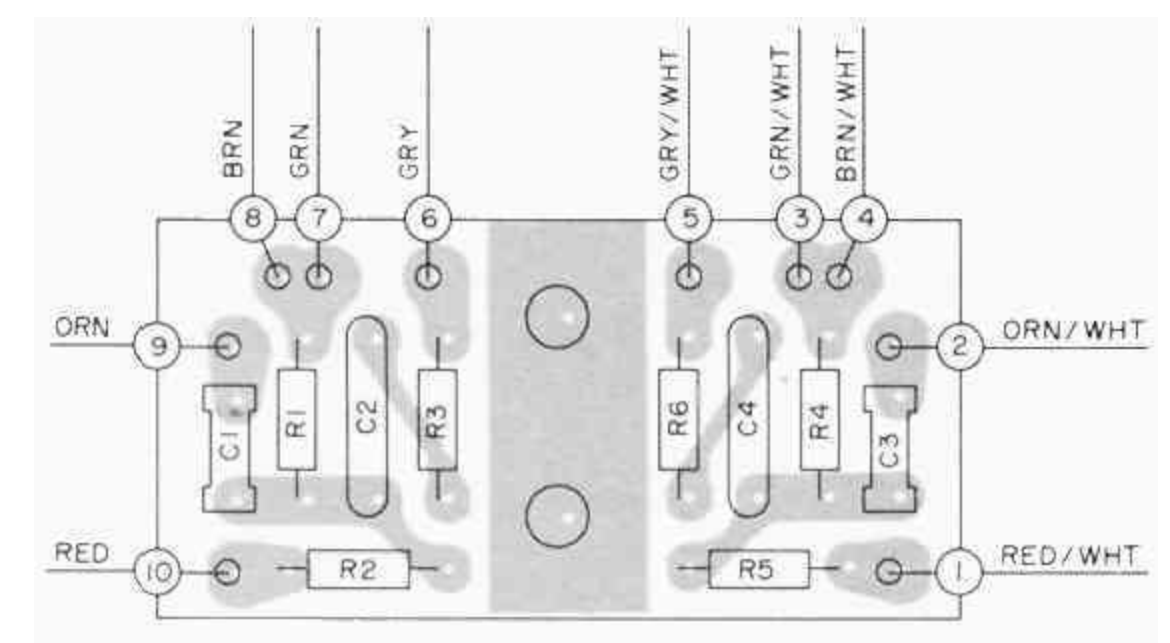

PREAMP SECTION

MA 6100

154-632



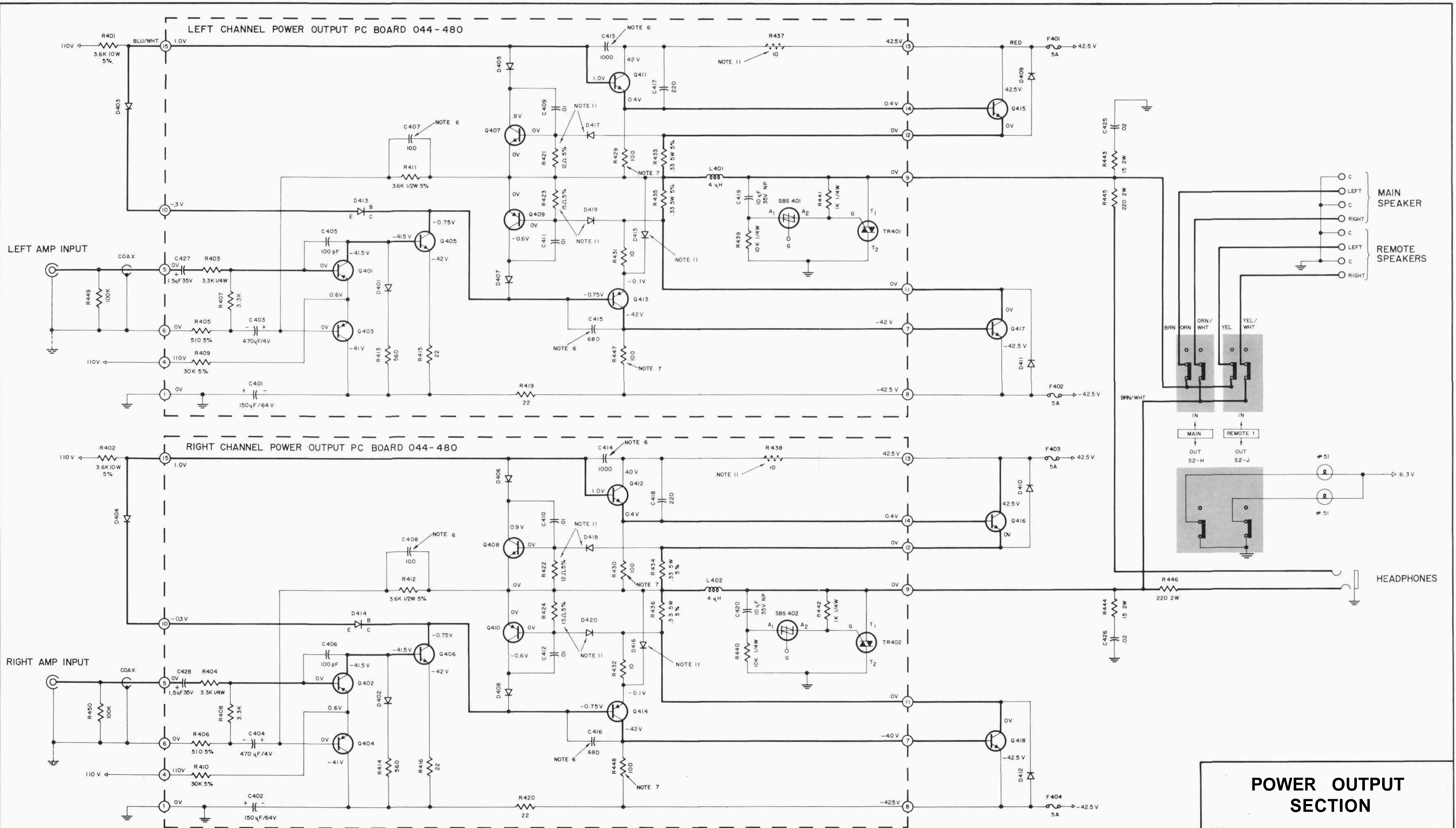

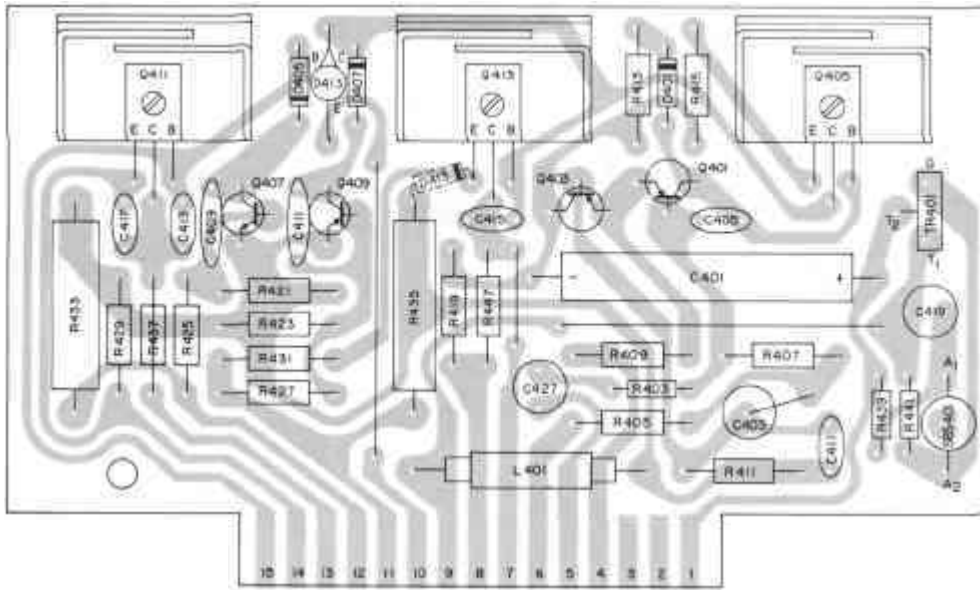

LEFT CHANNEL
POWER OUTPUT
PC BOARD 044-480

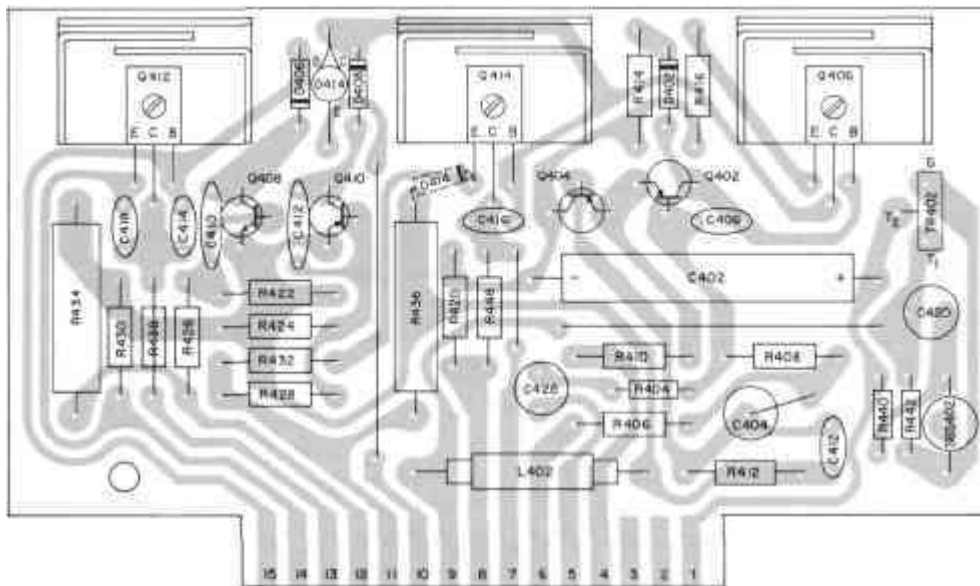

RIGHT CHANNEL
POWER OUTPUT
PC BOARD 044-480

REG & PHASE INVERTER PC BOARD 044-419

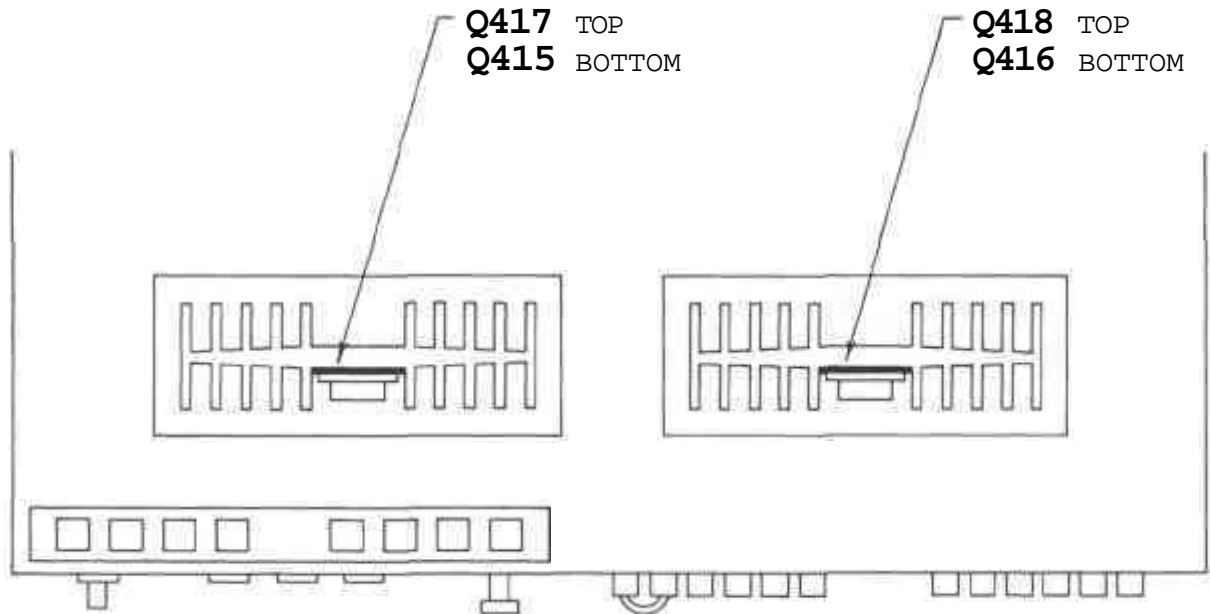
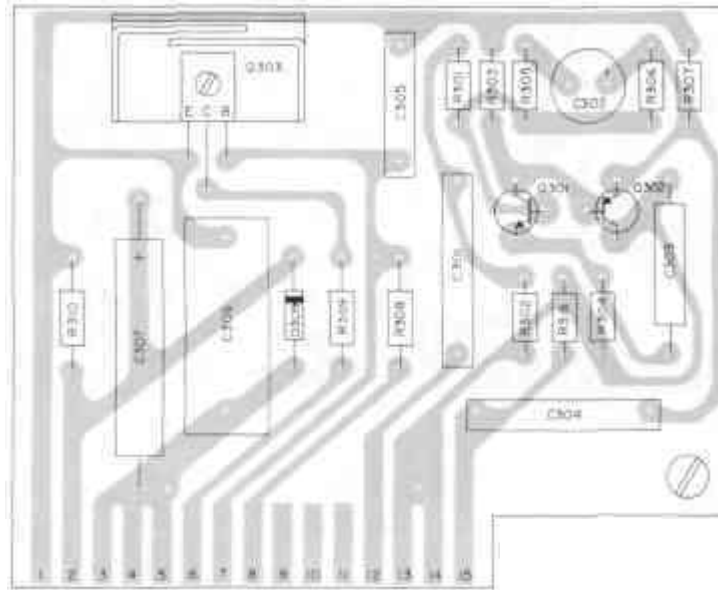

LOCATION OF TRANSISTORS NOT ON PC BOARD

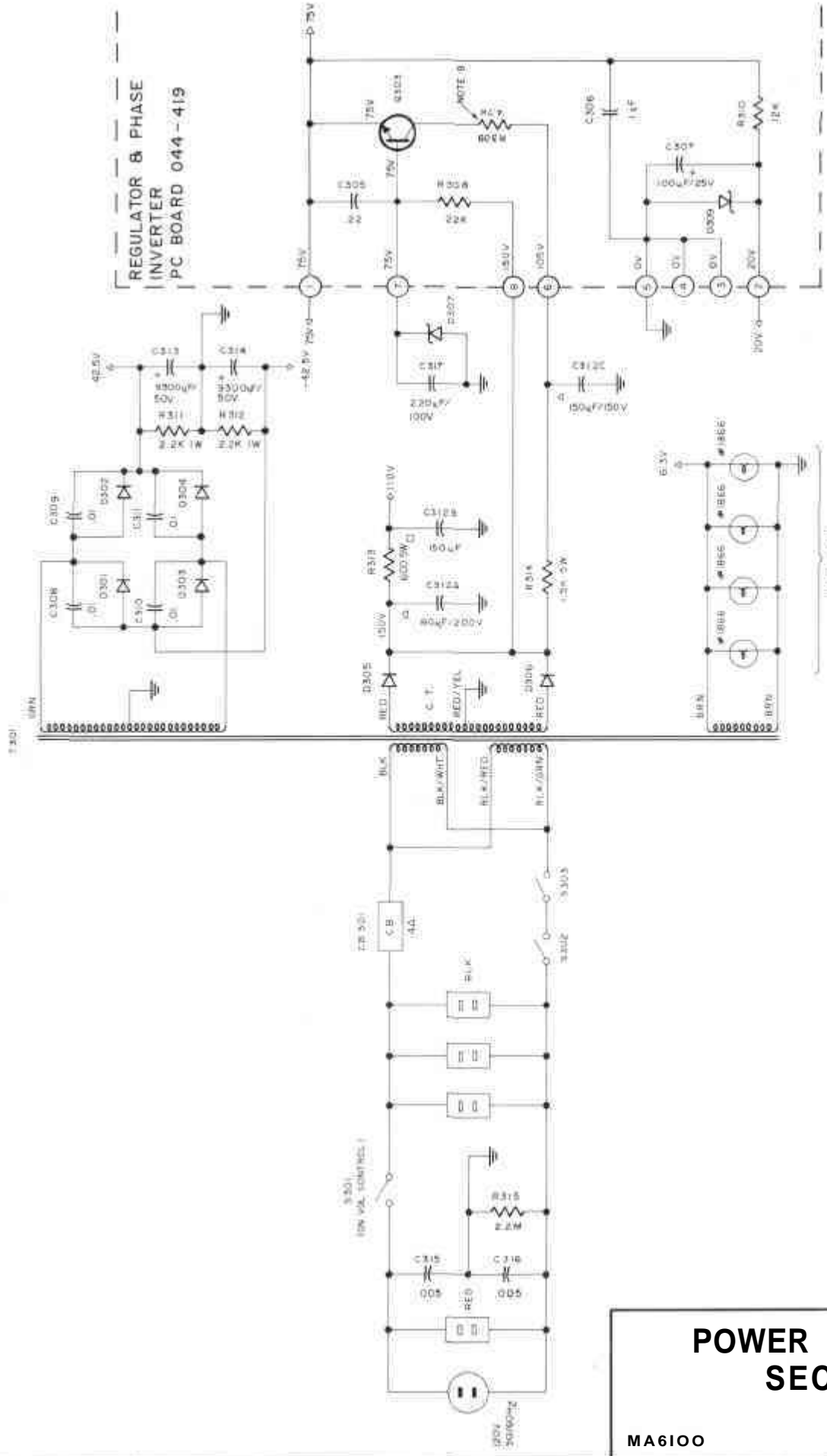

**POWER SUPPLY
SECTION**

1. Unless otherwise specified: Resistance values are in ohms, 1/4 watt, and 10% tolerance; Capacitance values smaller than 1 are in microfarads (μF); capacitance values greater than 1 are in picofarads (pF); inductors are in microhenries (μH).
2. Printed circuit board components are outlined on the schematics by dotted lines. The circled numbers around the dotted lines correspond to the numbers on the PC Board layouts.
3. The heavy lines on the schematics denote the primary signal path.
4. The terminal numbering of rotary switches is for reference only.
5. All voltages indicated on the schematics are measured under the following conditions:
 - a. Use of an 11 megohm input impedance VTVM.
 - b. All voltages $\pm 10\%$ with respect to chassis ground.
 - c. No signal at input terminals.
 - d. AC input at 120 volts, 50/60 Hz.
 - e. Front panel controls at:

Volume	Fully CW	Tape mon.	out
Input selector	Aux	Tape copy	out
Mode selector	Stereo	Filters	out
Balance control	Zero	Phase	out
Como	Flat	Speakers	out
Tone controls	Flat		
6. In units with Serial No's below AE1453; C415 & C416 are 1000pF. C413 & C414 are 1000 μF and C407 & C408 are 470pF.
7. In early export units R429, R430, R447 & R448 are 470 Ω .
8. In units with Serial No's below AE2557; C117 and C118 are 12pF.
9. In units with Serial No's below AE2075; R309 is D308. (McIntosh Part No. 070-064)
10. In units with Serial No's below AE2122; R211 & R212 are McIntosh Part No. 134-354 and R227 & R228 are McIntosh Part No. 134-253.
11. In units with Serial No's below AE3988; R421, R422, R423 & R424 are 100 Ω 5% 1/2W; R425, R426, R427, & R428 are used; D417, D418, D419 & D420 are not used; R437 and R438 are used and D415 and D416 are not used.

REPLACEMENT PARTS

All parts not listed are common items obtainable from radio parts jobbers.

Replacement parts may be obtained when ordered by PART NUMBER from:

McIntosh Laboratory, Inc.
Customer Service Department
2 Chambers Street
Binghamton, New York 13903
(telephone 607-723-3512)

CAPACITORS

Symbol Number	Description	Part Number
C101, 102	Mylar .47 μ F 250V	064-069
C105, 106	Ta. Elect 10 μ F 63V	066-221
C107, 108	Ta. Elect 10 μ F 63V	066-178
C111, 112	Mylar .4 μ F 250V	064-069
C113, 114	Ta. Elect- 100 μ F 16V	066-226
C115, 116	Mylar .1 μ F	064-067
C119, 120	Mylar .22 μ F 250V	064-068
C123, 124	Ta. Elect 100 μ F 16V	066-226
C125, 126	Mylar .22 μ F 250V	064-068
C127, 128	Mylar .1 μ F	064-067
C129, 130	Mylar .022 μ F 250V	064-102
C131, 132	Mylar .01 μ F 250V	064-040
C137, 138	Mylar .47 μ F 250V	064-069
C201, 202	Mylar .22 μ F 250V	064-068
C209, 210	Mylar .01 μ F 250V	064-040
C212, 213	Mylar .022 μ F 250V	064-102
C301	Mylar .47 μ F 250V	064-069
C302	Ta. Elect 10 μ F 63V	066-221
C303	Elect. 33 μ F 40V	066-204
C305	Mylar .22 μ F	064-096
C306	Mylar 1 μ F 250V	064-088
C307	Elect. 100 μ F 40V	066-206
C312	Elect. 80/150/150/200 μ F 200/200/150/100V	066-191
C313, 314	Elect. 9300 μ F 50V	066-162
C317	Elect. 220 μ F 100V	066-201
C401, 402	Elect. 150 μ F 63V	066-205
C403, 404	Elect. 470 μ F 4V	066-136
C419, 420	Elect. 10 μ F 35V	066-173
C427, 428	Ta. Elect 1.5 μ F 20V	066-158

DIODES

D301, 302	Si. Rectifier	070-041
D303, 304	Si. Rectifier	070-041
D305, 306	Si. Rectifier	070-031
D307	Zener 75V	070-025

D417, 418	Si. Rectifier	070-046
D419, 420	Si. Rectifier	070-046
0308	Si. Rectifier	070-031
D309	Zener 20V	070-064
D401, 402	Si. Rectifier	070-047
D403, 404	Si. Rectifier	070-046
D405, 406	Si. Rectifier	070-047
D407, 408	Si. Rectifier	070-047
D409, 410	Si. Rectifier	070-031
D411, 412	Si. Rectifier	070-031
D413, 414	Ge. PNP Transistor	132-098
D415, 416	Si. Rectifier	070-047

FUSES

F401, 402	Fuse 5A	089-014
F403, 404	Fuse 5A	089-014
CB301	Circuit Breaker 4A	088-007

CHOKES

L401, 402	Choke 4 μ H	122-105
-----------	-----------------	---------

TRANSISTORS

Q101, 102	Si. PNP transistor	132-096
Q103, 104	Si. PNP transistor	132-096
Q105, 106	Si. NPN transistor	132-095
Q107, 108	Si. NPN transistor	132-093
Q109, 110	Si. NPN transistor	132-093
Q111, 112	Si. NPN transistor	132-093
Q113, 114	Si. NPN transistor	132-095
Q115, 116	Si. NPN transistor	132-095
Q301	Si. NPN transistor	132-094
Q302	Si. PNP transistor	132-096
Q303	Si. NPN transistor	132-078
Q401, 402	Si. PNP transistor	132-056
Q403, 404	Si. PNP transistor	132-056
Q405, 406	Si. NPN transistor	132-081
Q407, 408	Si. NPN transistor	132-021
Q409, 410	Si. PNP transistor	132-032
Q411, 412	Si. NPN transistor	132-080
Q413, 414	Si. PNP transistor	132-079
Q415, 416	Si. NPN transistor	132-128
Q417, 418	Si. NPN transistor	132-128

POTENTIOMETERS

R201	Balance control	134-240
R210	Volume control	134-239
R211	Bass trim control	134-354
R212	Bass trim control	134-254

POTENTIOMETERS

R215	Treblecontrol	134-238
R2I6	Bass control	134-237
R227	Treble trim control	134-253
R228	Trebletrimcontrol	134-253

RESISTORS

R3I3	Wirewound 600Ω	5W	139-043
R314	Wirewound 1.5K	5W	139-079
R401,402	Wirewound 3.6K	10W	139-047
R433,434	Wirewound .33Ω	5W	139-080
R435,436	Wirewound .33Ω	5W	139-080

SWITCHES

SI	Input selector switch	146-153
S2	Pushbuttonswitch	150-011
S3	Mode selector switch	146-134

TRANSFORMERS

T30I	Power transformer	044-418
------	-------------------	---------

THYRISTORS & TRIGGERS

SBS401,402	Bilateral switch	131-004
TR401,402	Triac	131-005

FRONT PANEL & TRIM

Front panel	044-423
Front panel end caps	018-154
Balance control knob	044-375
Comp control knob	090-100
Bass knob (front)	044-375
Bass knob (rear)	090-100
Treble knob (front)	044-375
Treble knob (rear)	090-100
Volume control knob	044-372
Mode selector knob	044-372
Input selector knob	044-372

LAMPS

Panel illumination #1866	058-014
Switch indicator #51	058-021

MOUNTING SYSTEM

Shelf bracket (right)	043-622
Shelf bracket (left)	043-623
Mounting template #100	038-179
Hardware package	043-608

MISCELLANEOUS ITEMS

Plastic feet	017-156
Shipping carton	044-510
Owners manual	038-611
Line cord	170-021