

Scott . . . where innovation is a tradition



H. H. Scott, Inc. 111 Powdermill Road, Maynard, Mass., 01754

SERVICE MANUAL
FOR
MODEL 342B/382B

SPECIFICATIONS

TUNER (FM-MPX)

Usable Sensitivity (IHF)	2.0 microvolts
Cross Modulation Rejection	80 db
Signal to Noise Ratio	below 100% modulation 60
Total Harmonic Distortion	0.8%
Frequency Deviation (Drift)	0.02%
*Frequency Response	30 to 15,000 Hz \pm 1 db
Capture Ratio	2.5 db
Selectivity	42 db
Tuning Range	87 to 108 mc
Accuracy of Calibration	0.5%
Separation	40 db or more
FM & IF Limiting Stages	9

*This is limit of FCC Stereo Broadcast specifications. All H. H. SCOTT tuners have far wider frequency response.

TAPE OUTPUT

Rated Voltage Output to Tape Recorder	0.5 v
Minimum Recommended Load Resistance	47 k ohms

PRE-AMPLIFIER

Input:

Tape Head - Input Impedance	47 k ohms
Signal for Rated Output	3 mv
S/N Ratio	60 db
Phono-Input Impedance (All Switch Positions)	47 k ohms
High Level Inputs - Input Impedance	60 k ohms
Signal for Rated Output	75 db
S/N Ratio	80 db
Frequency Response in Flat Position	18-25 khz 1.0 db
Treble Controls Measured at 10,000 Hz, Boost & Cut	10 db \pm 2 db
Bass Controls Measured at 30 Hz, Boost & Cut	12 db \pm 2 db
Scratch Filter	-6 db/octave: -3 db @ 5 k Hz
Loudness Compensation (maximum)	+ 12 db @ 50 Hz
Loudness Compensation	+ 4 db @ 10 k Hz

AMPLIFIERS

Power Ratio (watts per channel) @ 0.8% Harmonic Distortion @ 4 ohms	32.5 watts
@ 8 ohms	25 watts
Continuous Output Single Channel @ 8 ohms, 0.8% Harmonic Distortion	18 watts
Continuous Output Both Channels @ 8 ohms, 0.8% Harmonic Distortion	18 watts

AUDIO TEST

342B, 382B AUDIO SECTION

Total Harmonic Distortion	0.8%
Frequency Response	18-25,000 \pm 1 db
Power Bandwidth at Rated Distortion (IHF Method)	25-20,000 Hz
Hum and Noise (Phono)	-55
Range of Line Voltage and Frequency	105-120v, 50-60 Hz
Power Consumption - 117 v at 60 Hz (AC only)	25-95 watts

EQUIPMENT NEEDED

Audio Oscillator
VTVM
Oscilloscope
VOM
Load Box
Attenuator
Distortion Meter
Variac
AC Supply Fixture

Set Controls to the Following:

Input Selector	Extra
Stereo Switch	Stereo
Tone Controls	Flat "0"
Loudness	Min.
Stereo Bal. Sw.	Norm.
Noise Filter	OUT
Speaker Switch	ON
Power Switch	OFF

1. Bias and Balance Settings and Voltage Checks

Turn unit on - watch carefully for any signs of voltage shorts. With bias pots (1K) still full ccw (from top of unit), check supply for 48 to 50. Adjust bias pots for 0.8 mA current from each test point in the rear of the unit to ground.

Check power supply board	for 25V \pm 10%
Check power supply board	for 12V \pm 10%

2. Sensitivity Check

Audio osc. to EXTRA at .3V (+2 dB) input. Connect 8 ohm load to main speaker taps. Turn loudness pot to max., observe output of 18 watts (12V). Check tape output jack with troubleshooting lead for same output as signal.

3. Distortion Check

At 12V output max. distortion 0.6%.

4. Tape Monitor Switch Check

Audio osc. to EXTRA at .3 input to L channel. Note output at left channel speaker terminal. Put tape monitor switch in the IN position. Note loss of output. Connect input cable from L channel tape out to L channel tape in. Note restoration of signal out. Repeat process for R channel, then return tape monitor switch to out position.

5. Speaker Switch & Phone Jack Check

Speaker switch to OFF position. Note complete loss of signal. Loudness to min. Insert phone plug to phone jack, remove speaker leads, and connect to phone plug leads. Loudness to max. Note drop of 26 + dB. Switch main speakers in, note restoration of signal. Switch to remote speaker position on speaker taps and speaker switch. Note drop in output of 1 to 2 dB. Speaker switch off, note loss of signal. Return speaker switch to main position and load to main speaker taps.

6. Loudness Volume Check

Loudness pot to #4 flat, osc. to 1 kHz. Take reference. Osc. to 100 Hz. Note rise of 7dB +2. Switch osc. to 10 kHz. Note rise of 0 +2 dB. Loudness pot to max. Osc. 1kHz output 12V. Loudness to min., drop of 70 dB. Loudness pot to max.

7. Tracking Check

In 10dB steps check tracking of L & R channels, output may be no more than 3 dB between channels down to 40 dB down.

8. Crosstalk and Stereo Switch Check

At 1 kHz turn loudness pot to 10 flat, output to 12V, mono-stereo switch to stereo, bal switch to bal. left. Note drop of 0 dB. Bal. switch to bal. right. Note additional drop of 50dB. Return controls to previous settings. Loudness pot to max., attenuate to 0 dB on 1V range.

9. Tone Control Check (0dB 1V range)

<u>Bass 100 Hz</u>		<u>Treble 10 kHz</u>	
Boost	- 10 dB +2 dB	Boost	- 10 dB +2 dB
Cut	- 15 dB +2 dB	Cut	- 10 dB +2 dB

10. Frequency Response Check

Osc. 0 dB 1 kHz reference on 1V range. Sweep osc. from 35 Hz to 20 kHz, note maximum variation of +2 dB. 3 dB down point 20 Hz or lower
3 dB down point 30 kHz

11. Regulation Check

At 1kHz 0 dB 1 V range remove 8 ohm load switch. Output rise of 1dB max.

12. Noise Filter Check

At 5 kHz noise filter IN. Note 4 dB drop in output +2 dB.

13. Preamp Gain Check @1 kHz

Attenuate input 35 dB, input leads to phono low. Output 0 dB 1V range +1 dB. Stereo mono switch to mono, note drop of 7 dB in output. Stereo mono switch to stereo. Input selector switch to phono - high, note drop of 7 dB. Input selector switch back to phone - low, output 0 dB 1V range.

POWER SUPPLY

14. Preamp Frequency Response Check

1 kHz	0dB (ref)
10 kHz	-12 \pm 2 dB
100 kHz	+13 \pm 2 dB

15. Hum Checks (all inputs shorted)

<u>Position</u>	<u>Loudness Pot</u>	<u>Max Hum</u>
Extra	0	3 mV
Extra	10	5 mV
Phono High	10	30 mV
Phono Low	10	30 mV

16. Repeat steps 2 through 15 for R channel.

Q401, Q402 - QA-10

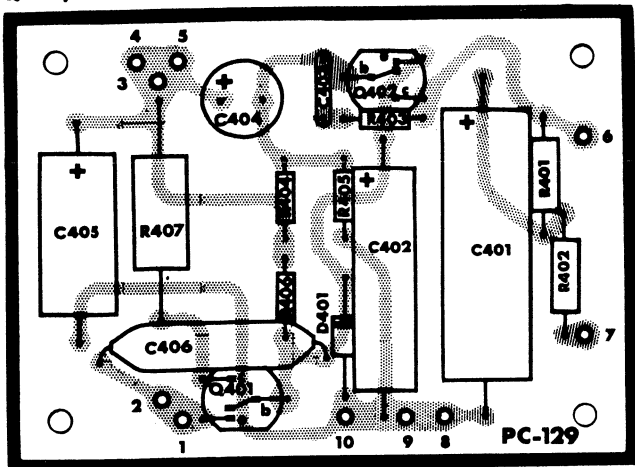

POWER SUPPLY Z-PC-PS-6

00

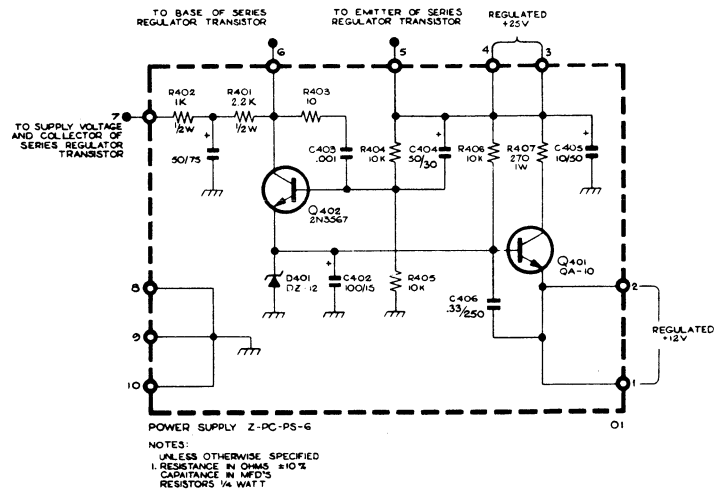

PRE AMP-TONE CONTROL-DRIVER

- Q1 — QA-14
- Q101 — QA-12
- Q2 — QA-14
- Q102 — QA-16
- Q3 — QA-11
- Q103 — QA-10
- Q4 — QA-14
- Q104 — QA-12
- Q5 — QA-16
- Q105 — QA-11
- Q6 — QA-10
- Q106 — QA-14
- Q7 — QA-12
- Q107 — QA-16

PRE AMP INPUT

PRE AMP OUTPUT

DRIVER INPUT

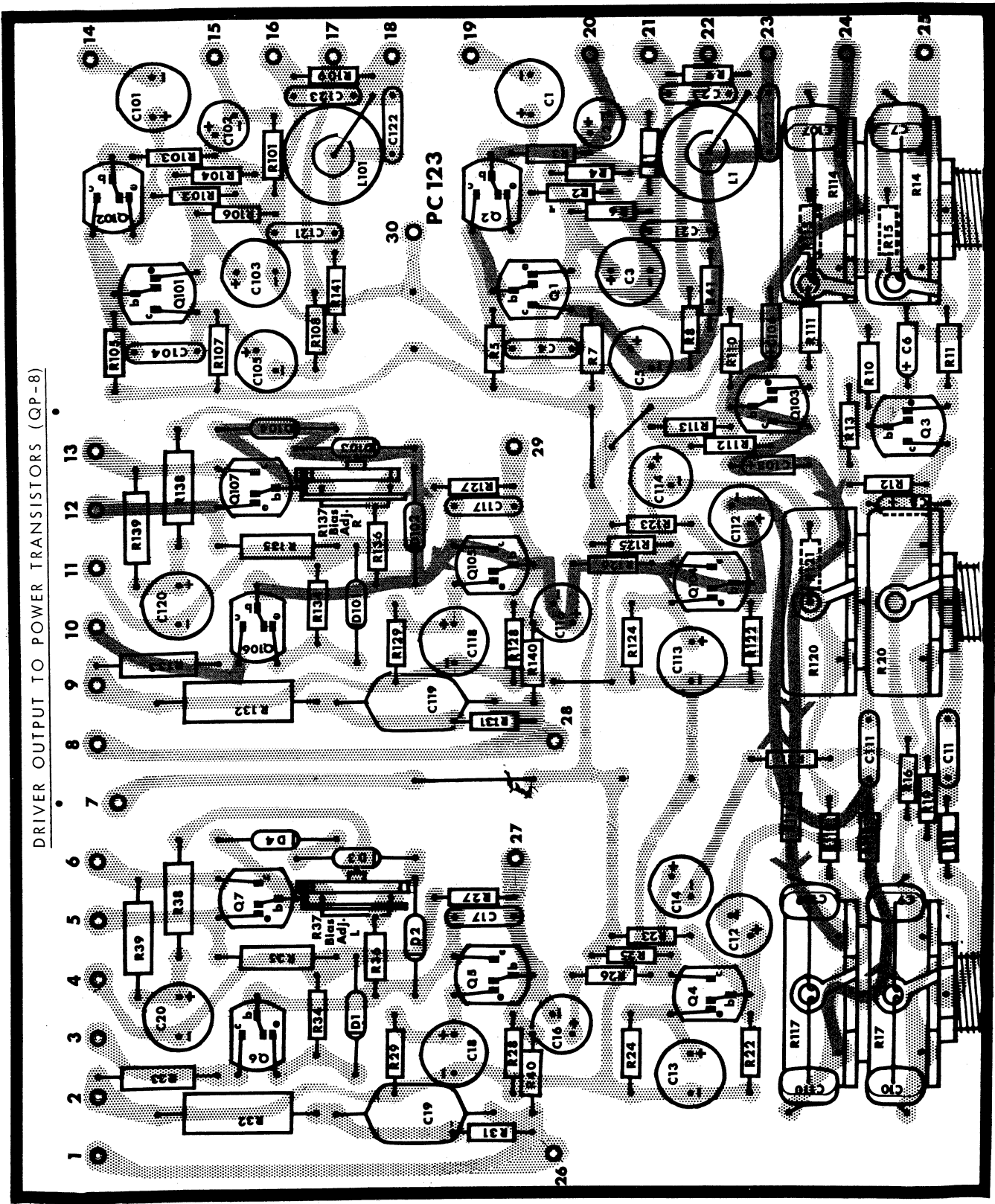

DRIVER OUTPUT TO POWER TRANSISTORS (QP-8)

LOUDNESS

TREBLE

BASS

LINE SHOWS SIGNAL PATH THRU AUDIO SECTION OF UNIT (RIGHT CHANNEL)

PRE AMP-TONE CONTROL-DRIVER

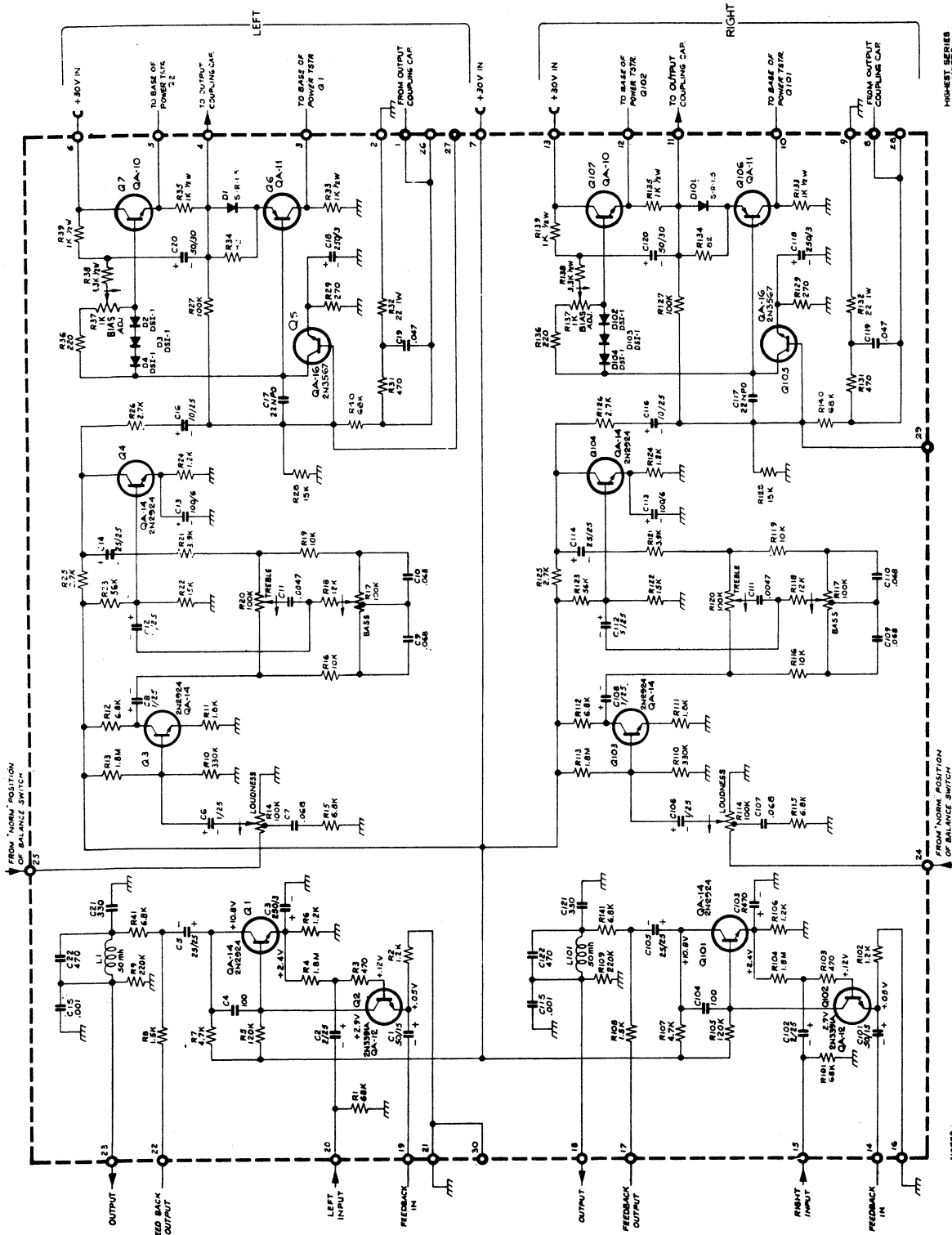

NOTES:
 1. UNLESS OTHERWISE SPECIFIED:
 RESISTANCE IN OHMS; 10K, CAPACITANCE IN MFD'S
 RESISTORS 1/4 WATT, ALL VOLTAGES DC 15%
 TOLERANCE UNLESS OTHERWISE SPECIFIED.
 2. ARROWS ON POTENTIOMETERS INDICATE CW ROTATION.
 3. ARROW HEADS INDICATE MAIN SIGNAL PATH.

HIGHEST SERIES
 C122
 R14C
 C14
 C17
 C17

00

TONE CONTROL-DRIVER Z-PC-TD-6

382B TUNER-AM SECTION

1. Switch tuner to AM position, output from tape output jack.
2. Connect signal generator at 455 kHz through .05 capacitor to green lead from If board to feedthrough terminal in front end. Clip ground lead to chassis. Remove RF transistor.
3. Peak IF's and detector for maximum A.G.C. (tuning meter indication) of audio noise output, using no modulation. Final peaking should be done with 20 uv from generator with output level of 100 mv +2 dB.
4. Remove signal generator coupling to IF's, connect generator to external antenna terminals. Install RF transistor.
5. Tune oscillator coil to 600 KHz and oscillator trimmer to 1600 kHz. Tune RF trimmer at 1400 KHz, and antenna slug at 800 KHz. Seal antenna core.
6. Repeat Step 5 until unit is aligned and max. output at given frequencies has been achieved. Calibrate:

590 KHz <u>+10</u> KHz	850 KHz	1030	1510 (tol. <u>+20</u> KHz)
------------------------	---------	------	----------------------------
7. Check signal-to-noise at 600 KHz, 100 uv for 10 dB, at 1400 KHz, 10 uv for 10 dB.
8. Remove generator connection from external antenna terminals, loop around low end of loop antenna using 47 ohm resistor, and at 1400 KHz peak antenna trimmer.
9. Check output level left and right tape jacks, at 100 uv output should be 250mv +2 dB.
10. With phones, check for AM calibration, oscillation, harmonic pickup, etc.
11. With AM tuned to low end of band, set meter adjust control so meter reads "0". Switch to FM and note little or no change max. difference between AM and FM across band, 2 meter divisions.

FRONT END ALIGNMENT

FM FRONT END ALIGNMENT FOR

342B and 382B FM SECTION

1. Connect RF generator to the antenna terminals with the following adaptations:

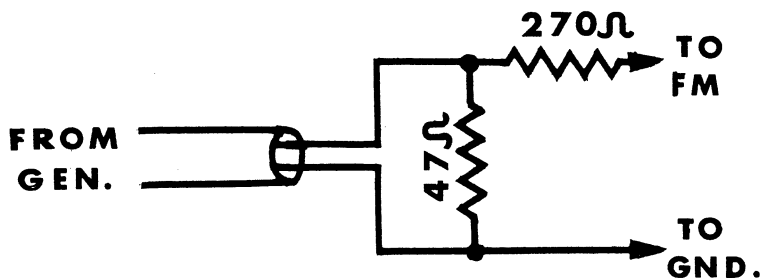

2. Set RF generator and FM tuning dial to 92 MHz. Generator output should be about 6 uv. Peak L205, L204 and L201 for maximum audio output.
3. Set generator and FM tuning dial to 106 MHz. Peak RF trimmer and mixer trimmer.
4. With about 3 uv from FM generator, repeat procedure until no further output is obtained. Signal should look like this:

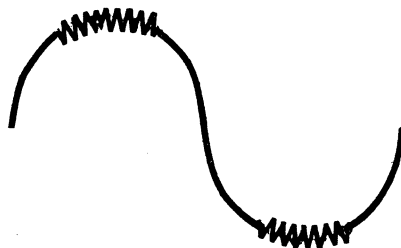

5. The only time that the oscillator mixer and trimmer should be touched is if the calibration is out of specification.

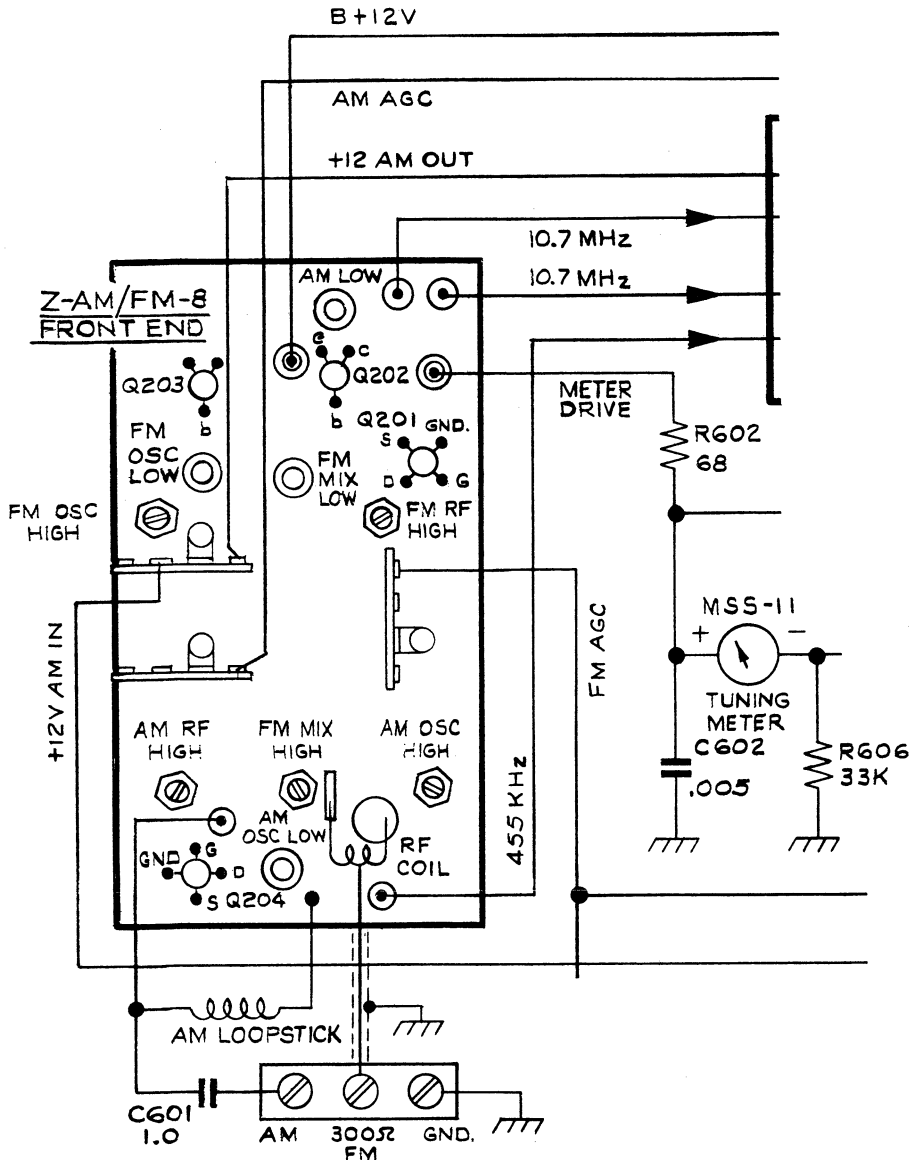

382-B

Mechanical layout of Front Ends denoting, Oscillator, Mixer, Antenna Coils and Voltages present under normal operating conditions

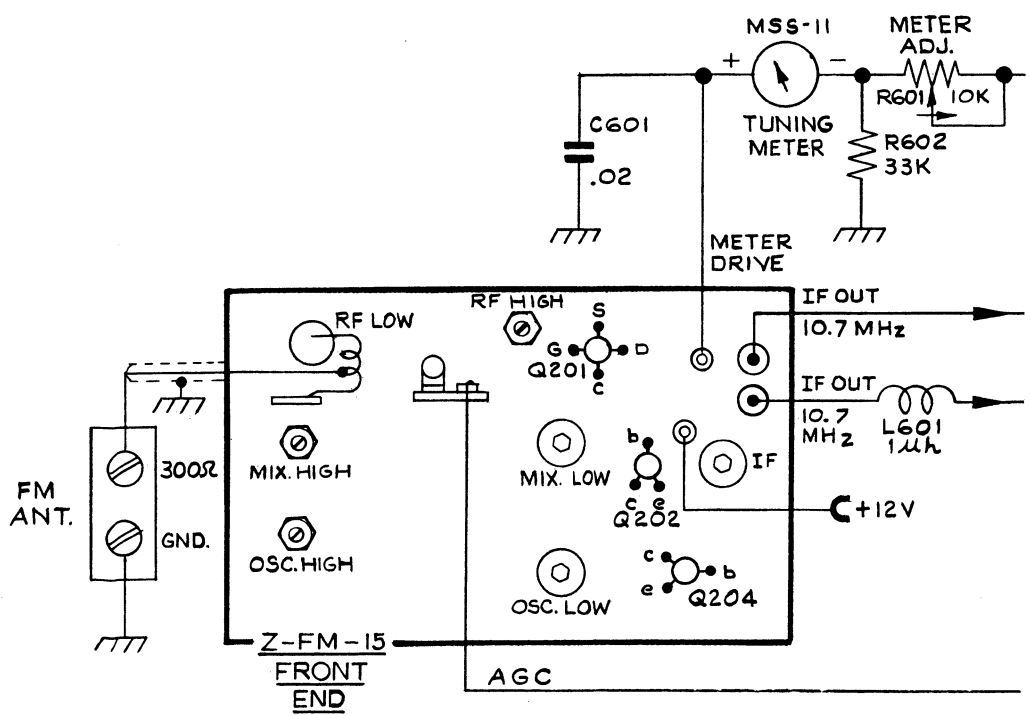

342-B

32-B ONLY

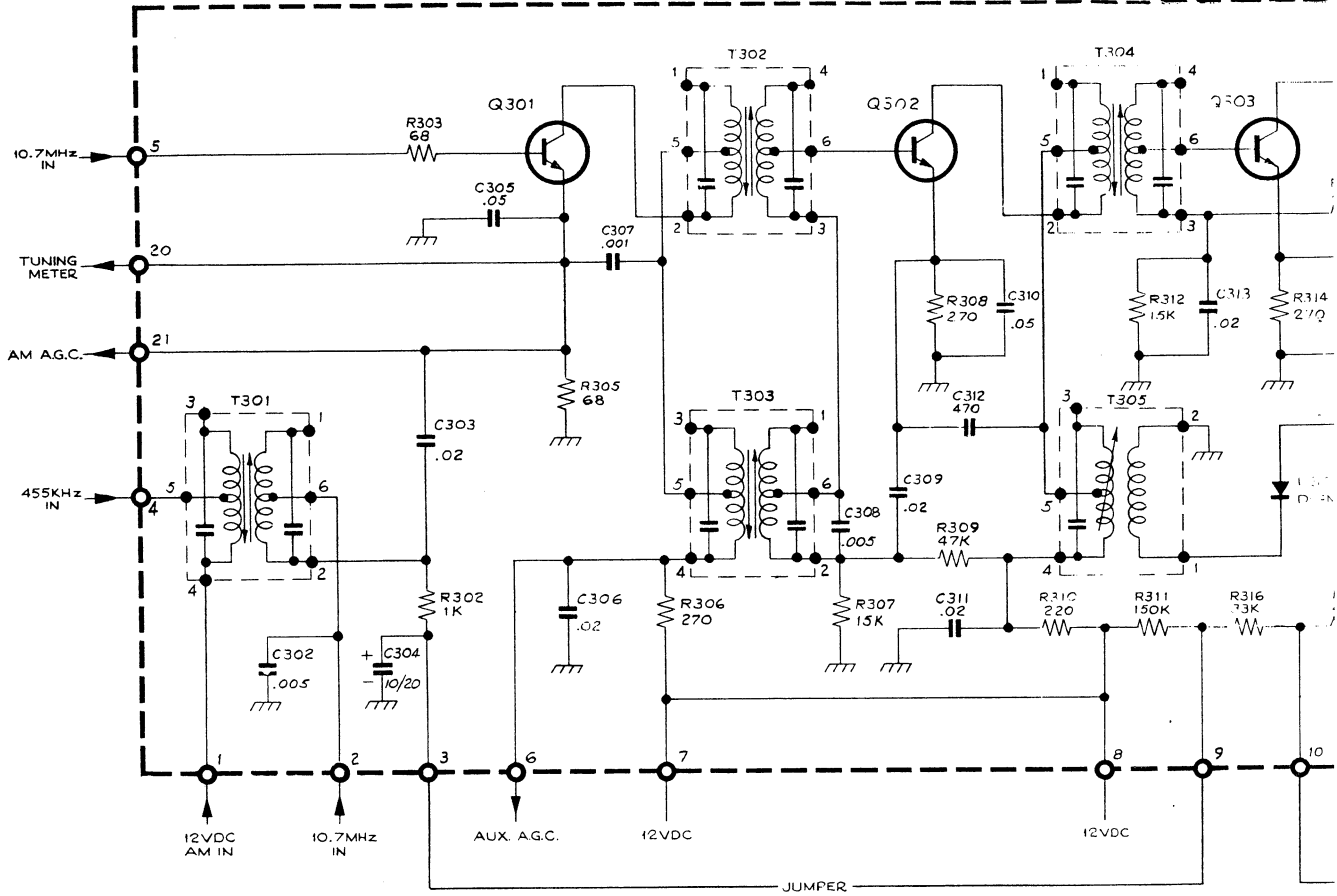

ALL VOLTAGES POSITIVE DC±15% MEASURED WITH 20 K ohm/V VOM AND 117 VAC LINE. FM VOLTAGES MEASURED WITH 300 OHM LOAD ON EXTERNAL FM ANTENNA TERMINALS. TUNER OFF-STATION. INPUT SWITCH IN FM POSITION. AM VOLTAGES MEASURED WITH LOOP ANTENNA, TUNER OFF-STATION, INPUT SWITCH IN "AM" POSITION.

Q301, Q302 - QSE1002

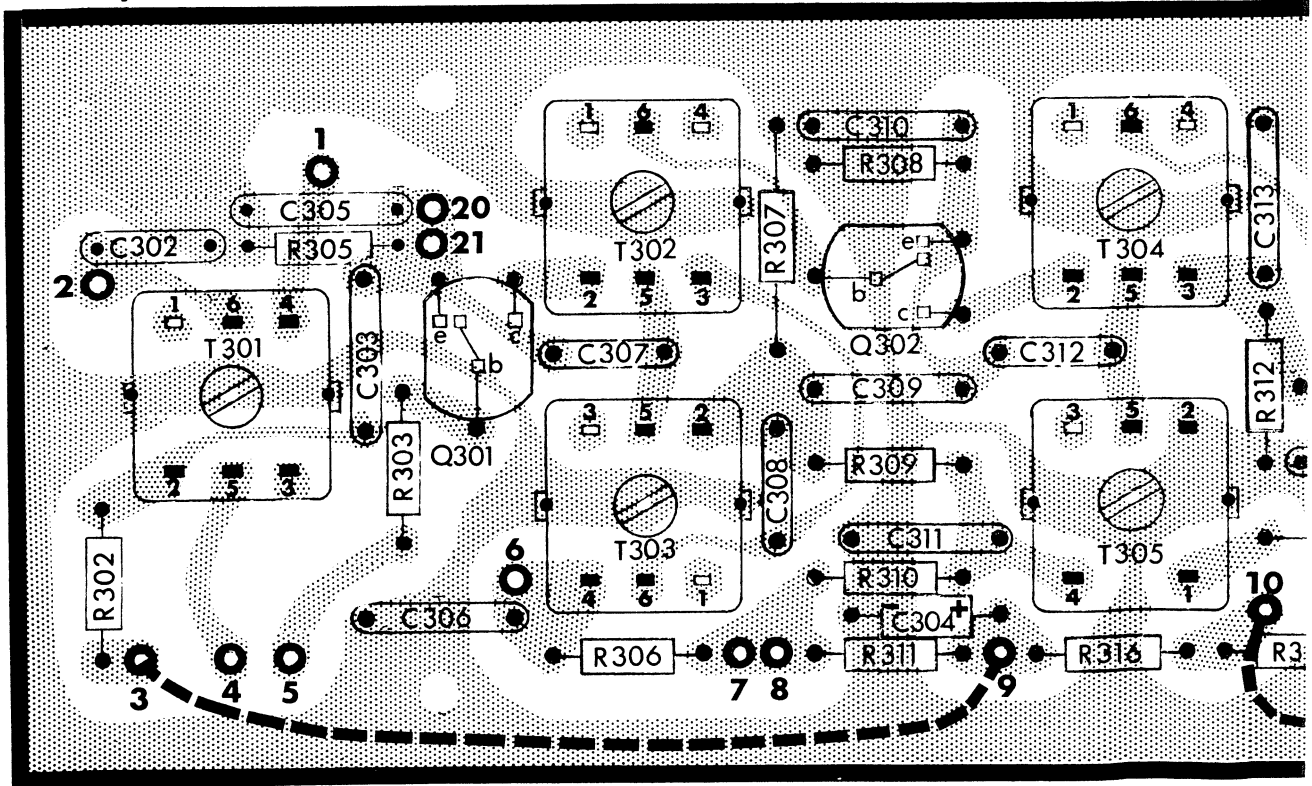

AM - FM I.F.

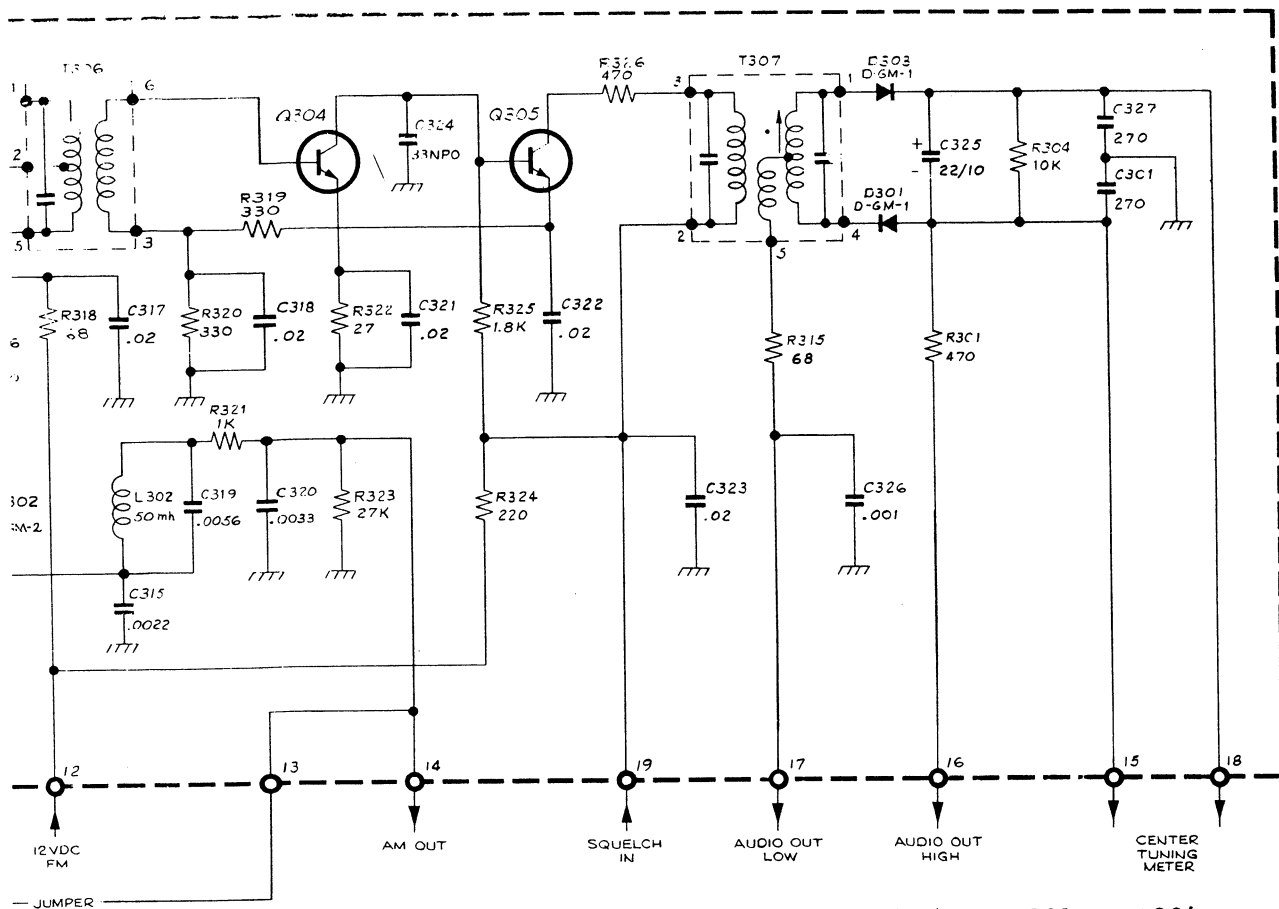

- HIGHEST SERIES NUMBERS
- C327
 - D304
 - L302
 - Q305
 - R326
 - T307

Q301 (FM)	Q301 (AM)	Q302 (FM)	Q302 (AM)	Q303	Q304	Q305
E-.75v	E-.85v	E-1.5v	E-1.55v	E-1.3v	E-.12v	E-1.8v
B-1.9v	B-1.22v	B-1.22v	B-1.95v	B-1.8v	B-.85v	B-2.5v
C-7.8v	C-8.4v	C-10v	C-10.2v	C-10.8v	C-2.5v	C-8.4v

QSE1001

Q304, Q305 - QSE3001

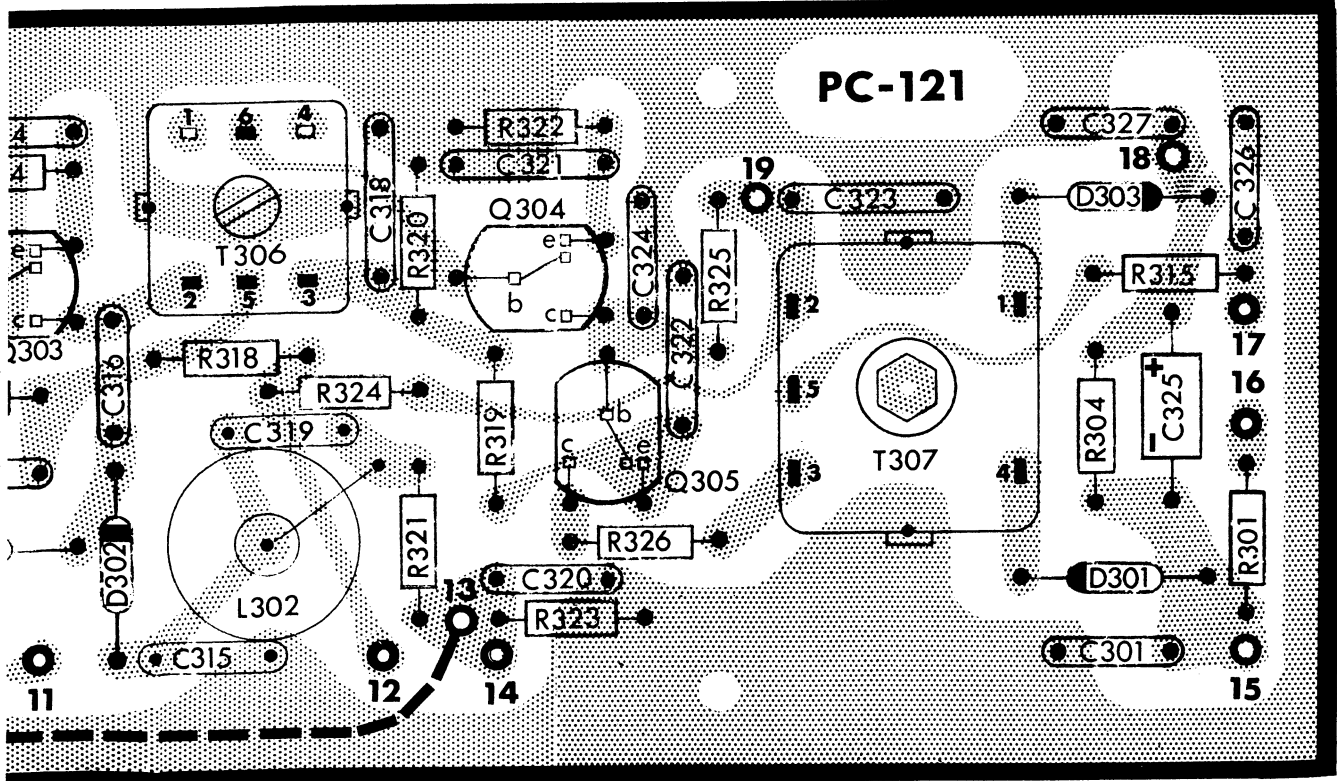

2-B FRONT END

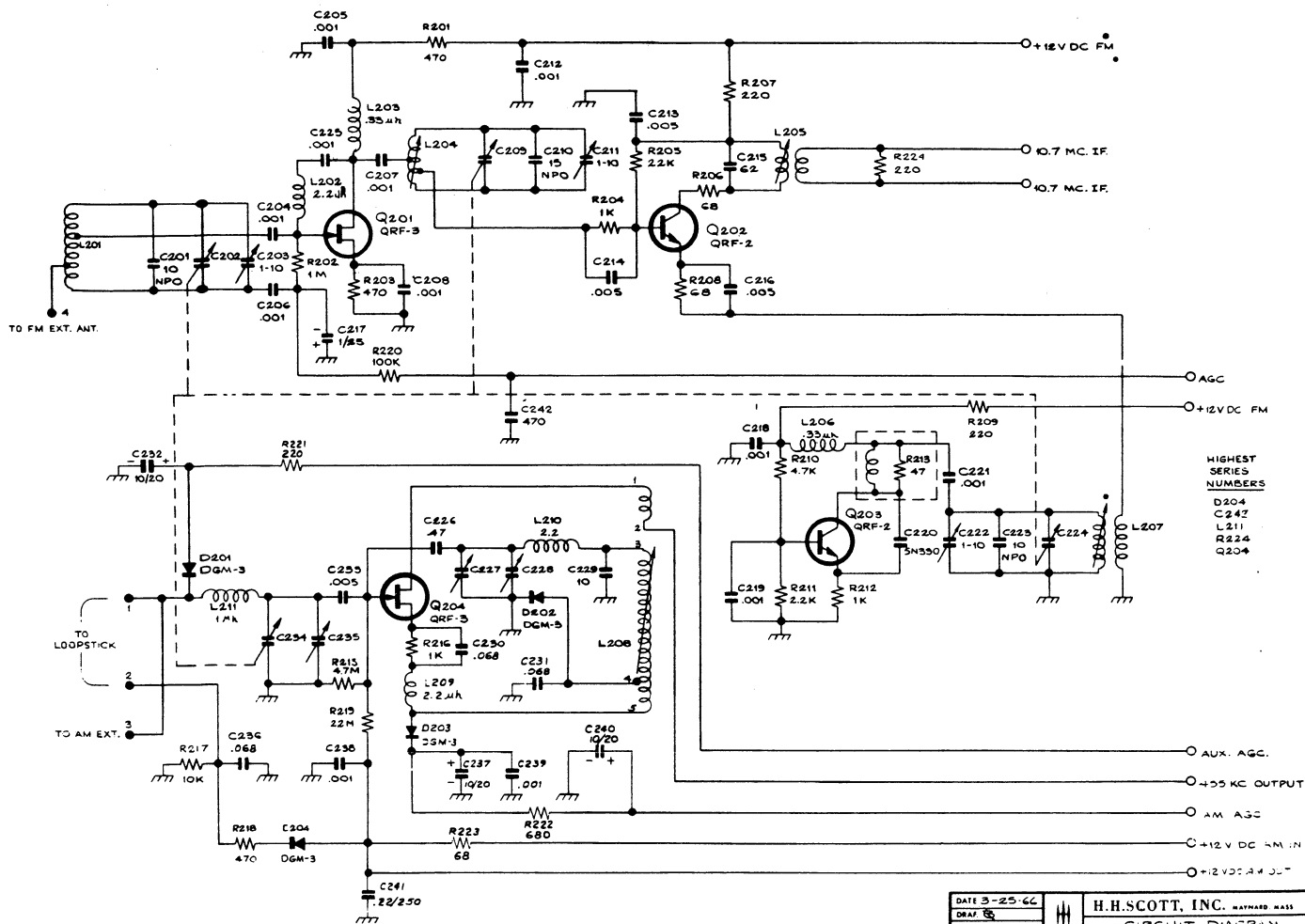

382-B

Z - AM - FM - 8

DATE 3-25-66	H.H. SCOTT, INC. WATNEED MASS
DRAW 8	CIRCUIT DIAGRAM
CH	SCALE
ENG JLF	SHEET 1 OF 1
PROD.	Z-AM/FM-8 C1

All voltages measured with 20,000 ohm/volt VOM; 300 ohm antenna and no signal.

Q201	Q202	Q203
G .025	B .45	B 3
D 9.2	E .05	E 2.6
S 1.05	C 10.8	C 10.2

Troubleshooting Guide

Trouble	Possible Remedy
Low gain	Replace Q201
No Output	Open LRFC 2.2 or .33 defective Q201, Q202, Q204
No AM signal	Open LRFC 2.2 (L209) Defective (L208) Defective D203
Oscillation	D203
Low or intermittent AM	Shorted Plates in tuning condenser

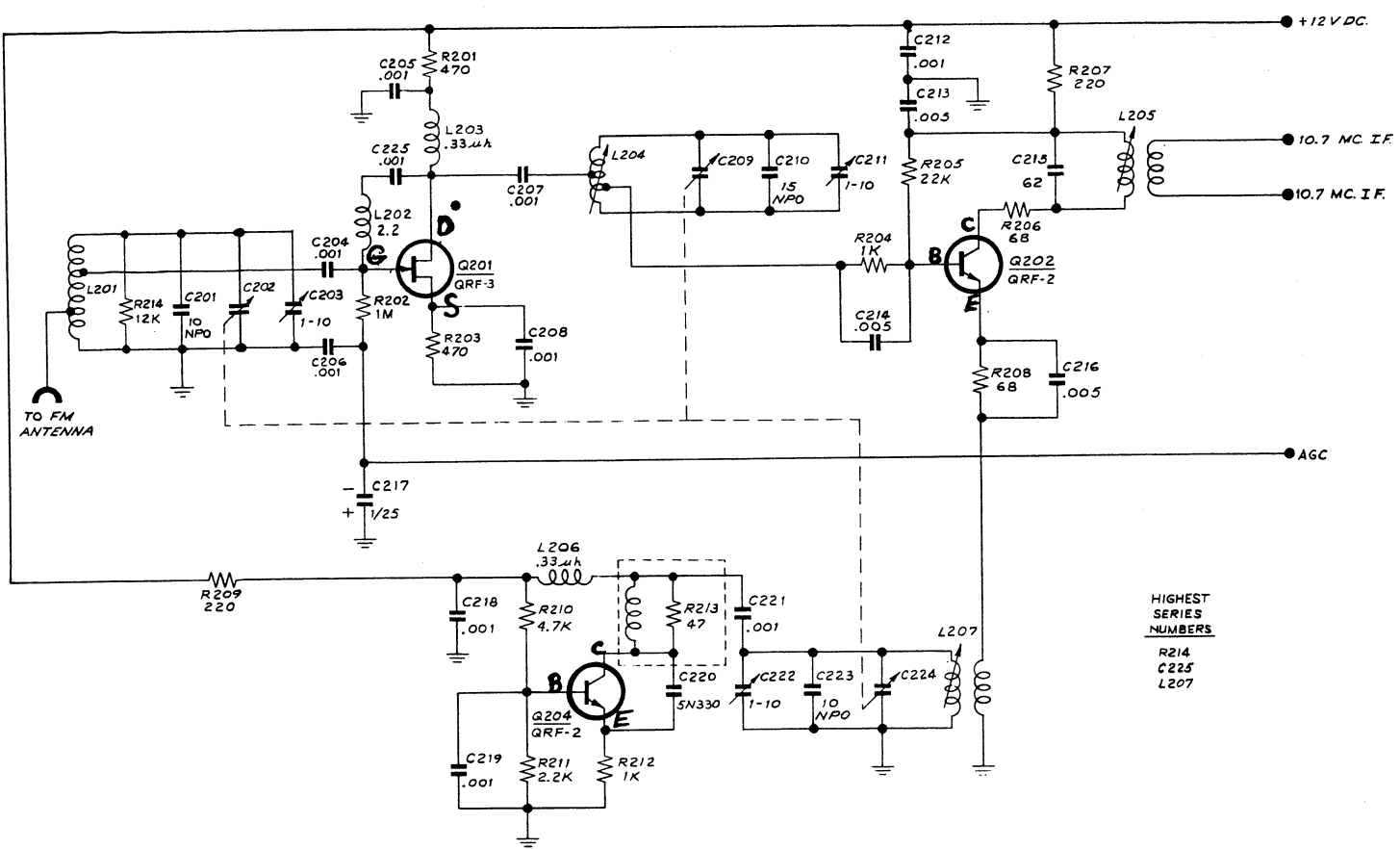

342-B

All voltages measured with 20,000 ohm/volt VOM; 300 ohm antenna and no signal.

<u>Q201</u>		<u>Q202</u>		<u>Q204</u>	
G	.025	B	.45	B	3
D	9.2	E	.05	E	2.6
S	1.05	C	10.8	C	10.2

Troubleshooting Guide

<u>Trouble</u>	<u>Possible Remedy</u>
Low gain	Replace Q201
No Output	Open LRFC 2.2 or .33 defective Q201, Q202, Q204

EQUIPMENT NEEDED

VTVM
Oscilloscope
VOM
Distortion Meter

FM Generator
MX Generator
Audio Generator

Set Controls to the Following:

Separation Pots Max CW
Input Select. Switch FM

1. Mono Alignment and Sensitivity Check

Front End and IF Alignment

With about 10 uv generator output, align and peak front end for max. output. With 3 uv input, align IF's for max. audio. With 1 or 2 K uv input, align detector for minimum distortion.

2. Sensitivity and Distortion

Measure sensitivity of tuner with 3 uv RF input. Must obtain 30 dB usable sensitivity at 92, 98, and 106 mc. Recheck distortion, 2K uv input. 400 Hz- max. distortion of 0.8%.

3. FM Hum Check

Tune to 91.5 mc, measure min. of 60 dB (AC plug may be reversed).

De-emphasis Check

Tune to 90 mc (change modulator to 8 KHz), note decrease of $12 \pm$ dB in output.

Calibration Check

Check calibration against stations - max. tolerance ± 2 mc.

4. Multiplex Alignment - Unit to Stereo

a) Pilot Adjustment - Scope probe (Low - Cap) to test point at base of Q3, peak L2 and L3 for max. pilot. With VOM, measure 2.5 to 3.5 dc across 2.2K resistor in the emitter of Q3.

b) With VOM across 2.2K resistor carefully tune L2 & L3 for max., then tune T1 for dip.

c) Separation Adjustment - Output from Ch. A. Adjust scope to obtain pattern and adjust L2 for min. output observing scope. Adjust A separation pot for min. output. Tuner output from Ch. B and adjust B separation pot for min. as outlined above. Repeat between A & B until no further improvement is seen.

d) Final separation measurements to be done in each channel:

<u>Audio Modulation</u>	<u>Minimum Separation</u>
400 Hz	30 dB

If separation specs are not met, recheck IF's for proper alignment. Also recheck steps 4.b) and 4.c)

e) Stereo Switchover Check

Check switchover point (at generators), min. 10 uV, max. 30 uV. Switchover may be adjusted by threshold pot on MX board.

f) Final Listen Check

Check all inputs and outputs (including phone jacks), switches and controls for proper operation. Check overall appearance and scrap inside unit. Check for proper switching of stereo light. Check calibration against stations specs are ± 0.2 mc.

TROUBLESHOOTING PROCEDURE FOR IC-IF-4

342-B ONLY

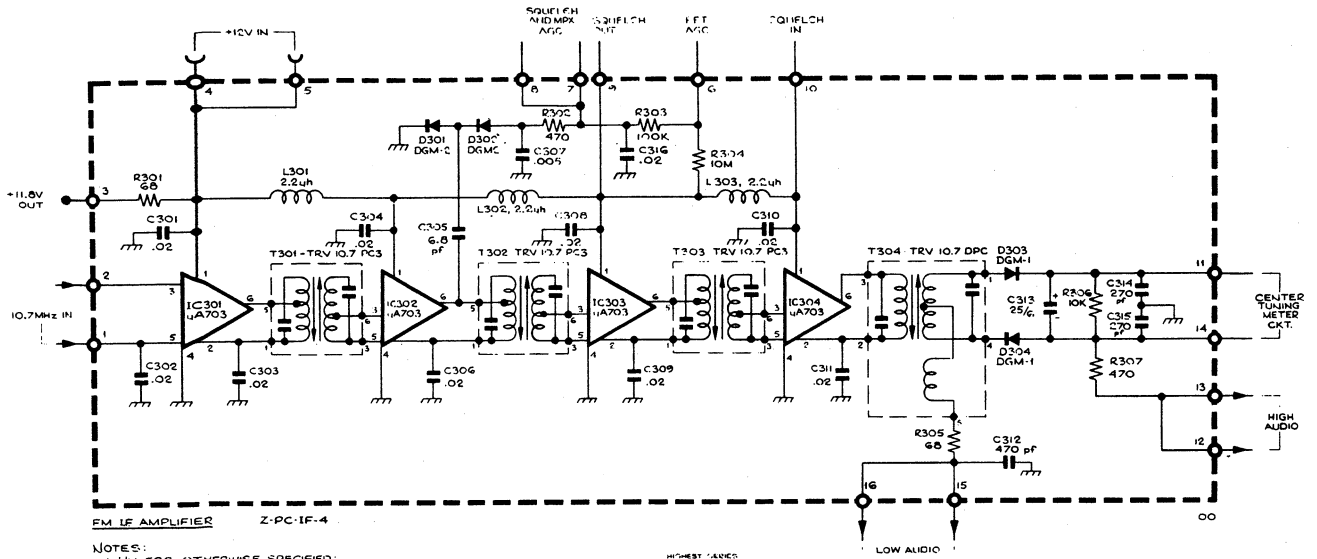

NOTES:
 1. UNLESS OTHERWISE SPECIFIED:
 RESISTANCE IN OHMS ±10%.
 CAPACITANCE IN MFD'S.
 RESISTORS 1/4 WATT.
 VOLTS DC ±5%. MEASURED WITH 20KΩ, V.V.O.M.
 2. ARROW - HEADS INDICATE MAIN SIGNAL PATH.

HOWARD JAMES
 NUMBERS:
 116 1307
 0704 1304
 1378 1304

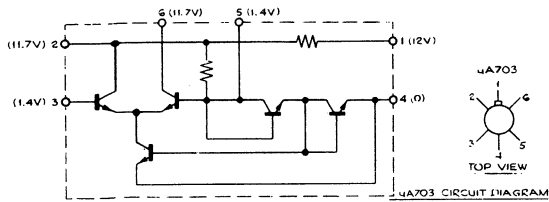

IC301, IC302 IC303, C304 -UA703

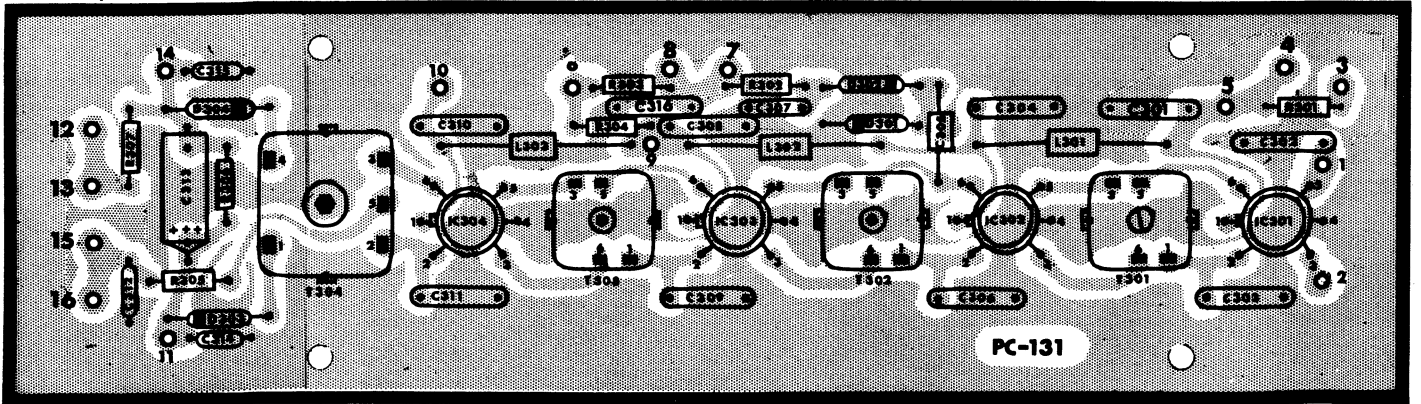

FM I.F. AMPLIFIER

Z-PC-IF-4

1

VOLTAGE CHECKS (UA703)

Pin 1 B+ 12 Volts

Set VOM on 3 volt scale: positive lead of meter on pin 1, negative lead on pin 2 and/or pin 6. If voltage is apparent, then that particular stage of IC is operating normally

No output or distortion
 Meter operates okay

check diodes D303 and D304 for defect

Meter pegging either direction

defective D301 or D302

- Q1- 2N2924
- Q2- 2N2925 or SE4010 or QA-15
- Q3- 2N3964 or 2N4249 or 2N4250
- Q4- 2N3567

STEP A & B OF MULTIPLEX ALIGNMENT

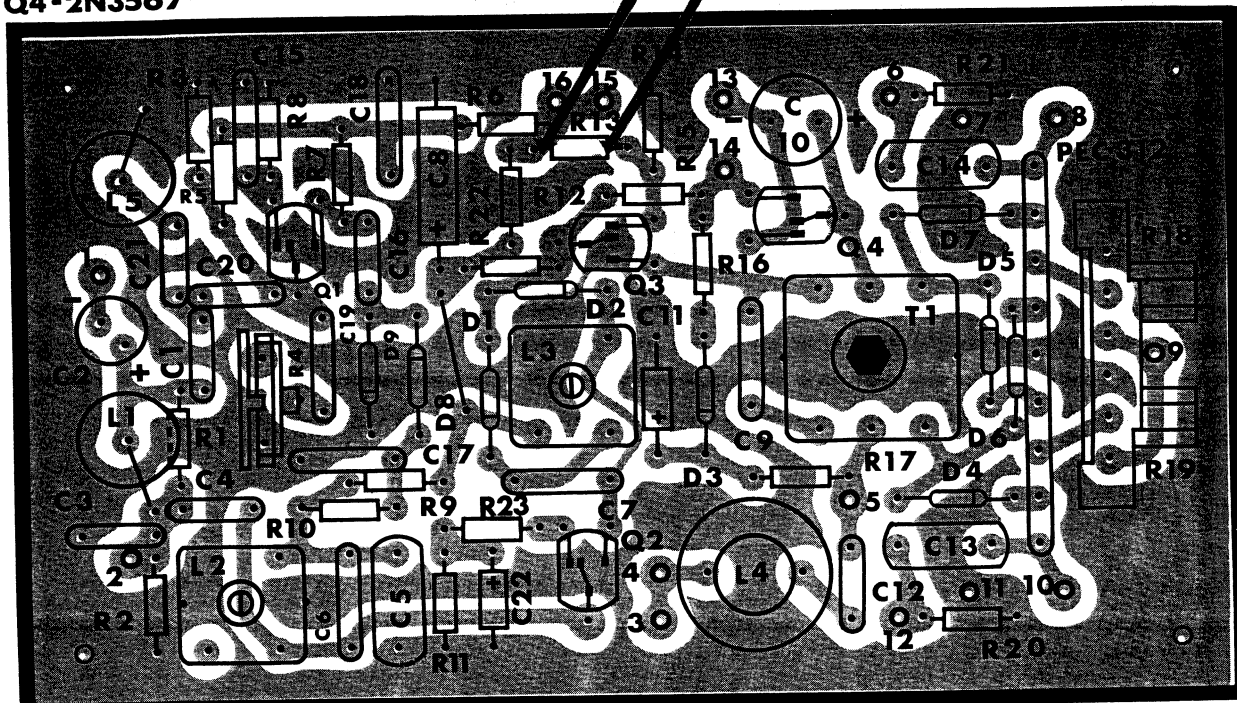

AUTOMATIC MULTIPLEX DEMODULATOR Z-PC-MX-14

01

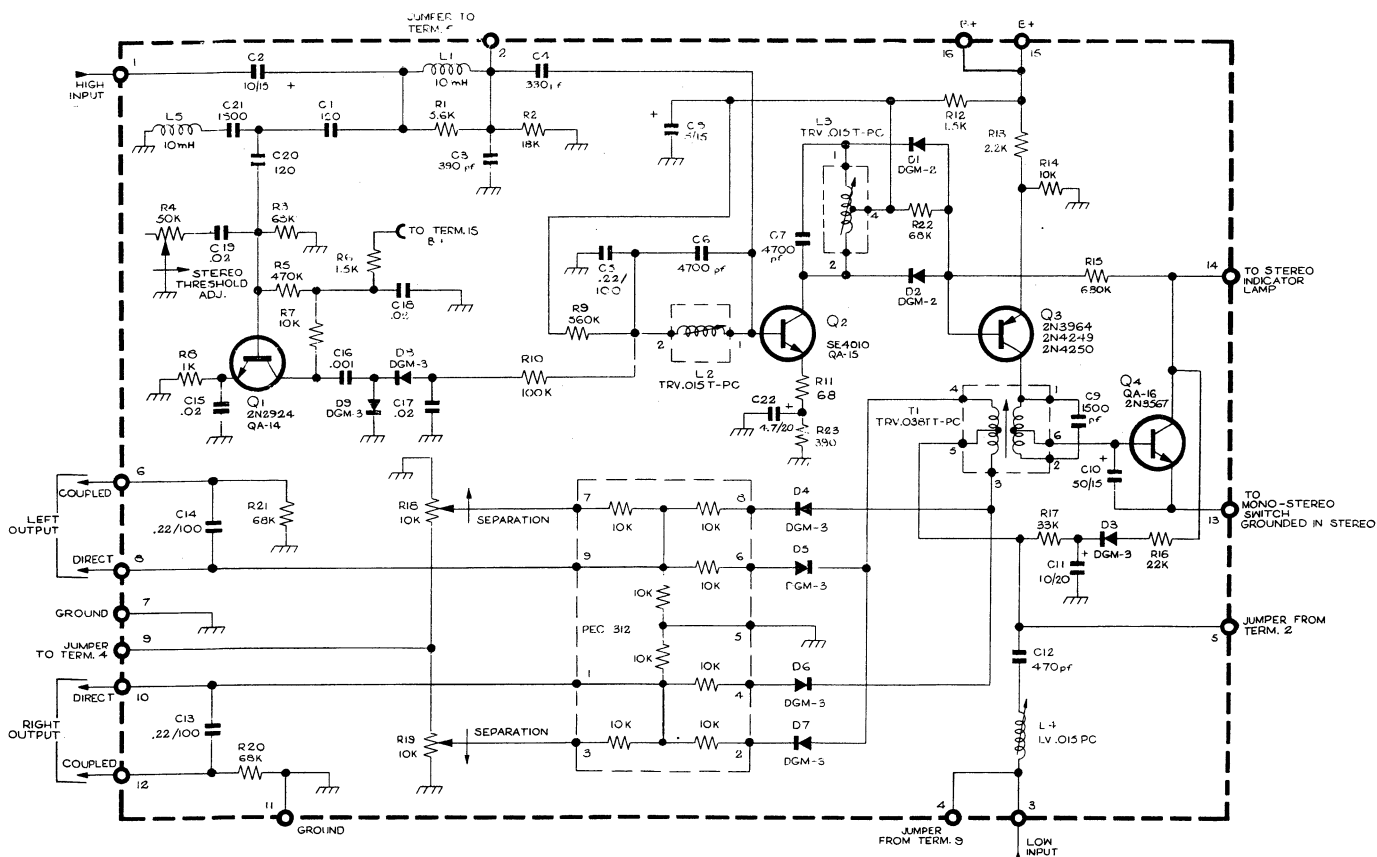

AUTOMATIC MULTIPLEX DEMODULATOR Z-PC-MX-14

5

NOTES:
 UNLESS OTHERWISE SPECIFIED: RESISTANCE IN OHMS $\pm 10\%$
 CAPACITANCE IN MFD'S RESISTORS 1/4 WATT.
 2 ARROWS ON POTENTIOMETERS INDICATE CW ROTATION.

ULTIPLEX

- Q1-2N2924
- Q2-2N2925 or SE4010 or QA-15
- Q3-2N3964 or 2N4249 or 2N4250
- Q4-2N3567

STEP A & B OF MULTIPLEX ALIGNMENT

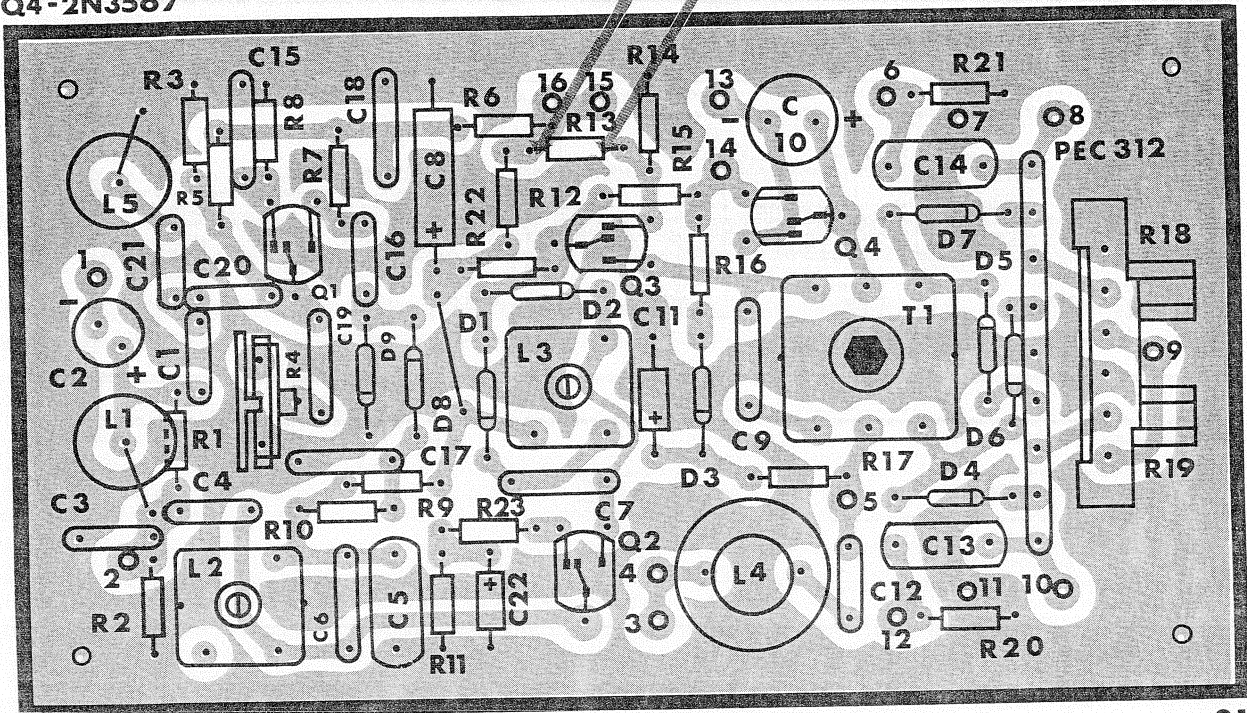

AUTOMATIC MULTIPLEX DEMODULATOR Z-PC-MX-14

01

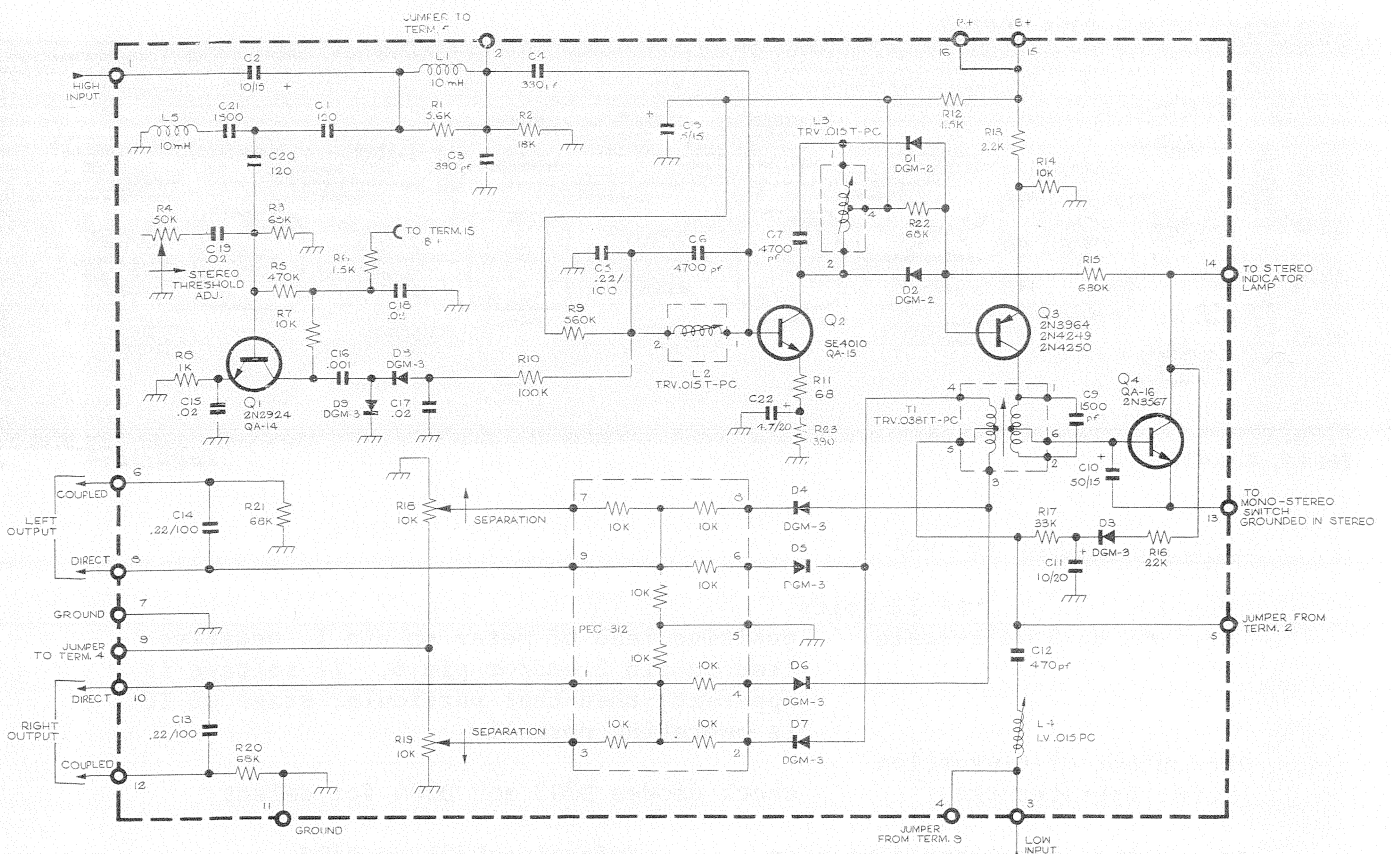

AUTOMATIC MULTIPLEX DEMODULATOR Z-PC-MX-14

- NOTES:
1. UNLESS OTHERWISE SPECIFIED: RESISTANCE IN OHMS $\pm 10\%$
 2. CAPACITANCE IN MFD'S RESISTORS $\frac{1}{4}$ WATT
 3. ARROWS ON POTENTIOMETERS INDICATE CW ROTATION

342-B/382-B PARTS PRICE LIST

<u>Part #</u>	<u>Description</u>	<u>Customer List</u>
A-DC-20	Dial Cord	\$1.75
A-FW-B	Flywheel Assembly	4.80
CETM-1000/30	Electrolytic Capacitor	2.45
CETM-1000/50	Electrolytic Capacitor	3.48
CMM- .22/250	Electrolytic Capacitor	1.50
F-AGX-2	Speaker Fuse	.24
F-SB-1½	Power Fuse	.45
J-3-ST-5	Phone Jack	.65
KN-001	Knob	.40
KN-002	Knob	.40
KN-005	Tuning Knob	.50
L-RC-2	Choke	.25
M-SS-11	Meter	5.95
N-342-B-1	Panel	14.40
N-D-FM-23	Dial Glass	2.94
QP-8	Power Transistor	6.00
QP-11	Power Transistor	3.84
RW2- .82	Wire Wound Transistor	.20
RW5-15-2X2	Stand Up Resistor	1.47
RCV-10K-PH	Potentiometer	1.00
SR-2-50	Rectifier	.80
SS-22-3/3A	Slide Switch	.40
SS-43	Slide Switch	.50
SPS-12-3	On-Off Switch	.48
SRW-115-2	Rotary Switch	5.75
TR-8-9	Power Transformer	18.00
V-PL-1819	Neon Lite Bulb	.40
V-PL-1847	Pilot Lite Bulb	.40
Z-FM-15	Front End	48.15
Z-PC-IF-4	IC Board	30.00
Z-PC-MX-14	Multiplex	26.56
Z-PC-TD-6	Driver Board	59.88
Z-PC-PS-6	Power Supply	11.40
Z-AM-FM-8	Front End	41.10