

SCHEMATIC DIAGRAM (TSR-580: FM/SW/MW/LW)

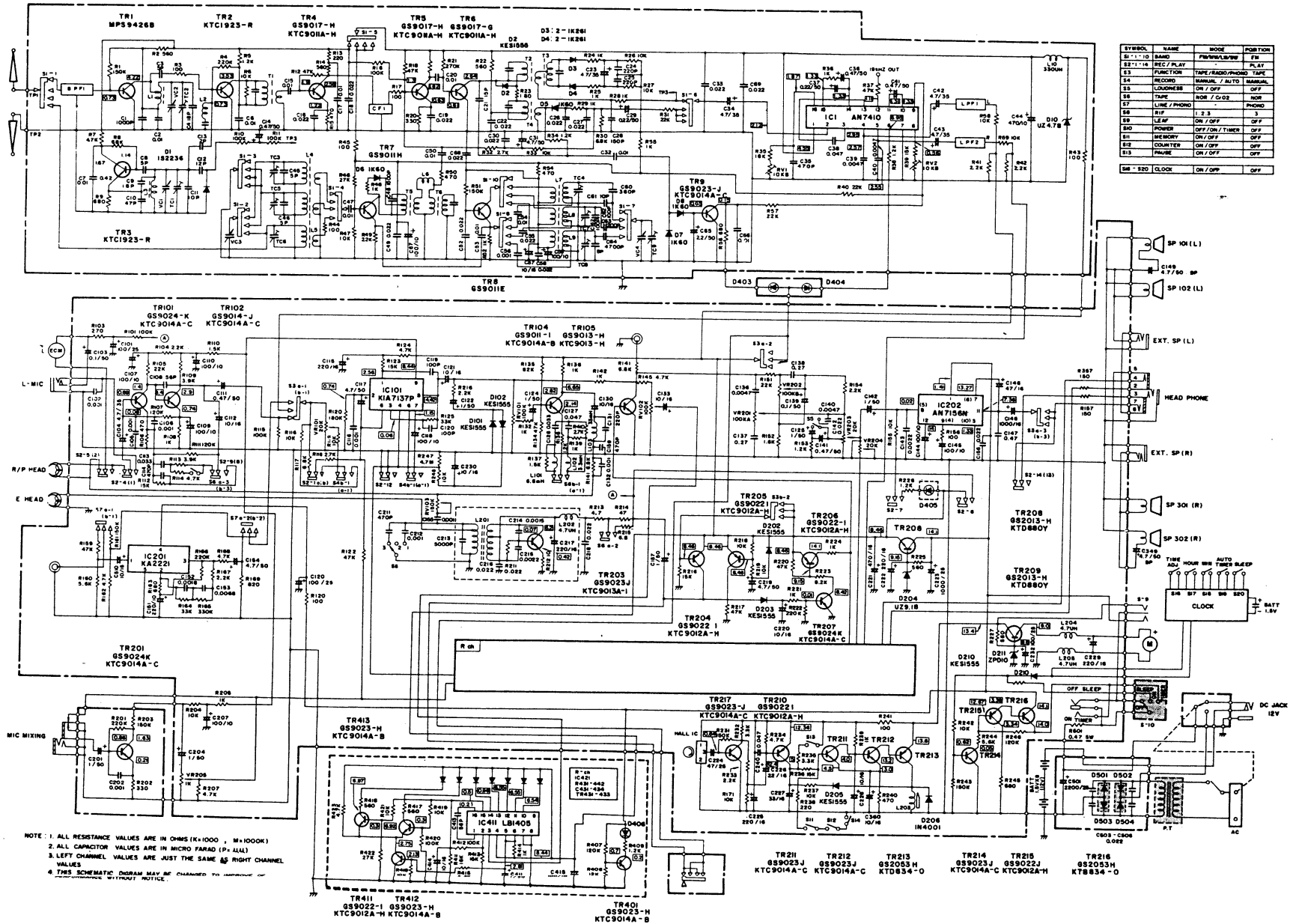

ELECTRICAL SERVICE PARTS LIST

SYMBOL NO.	PART NO.	DESCRIPTION	SYMBOL NO.	PART NO.	DESCRIPTION
INTEGRATED CIRCUITS					
IC1	668N061A	IC, AN7410	TR209	661N027A	TR, GS2013H
IC101, 301	668-605A	IC, KIA7137P	TR210	{ 661-030B	TR, GS9022I
IC201	{ 668-632A	IC, KA2221	TR211, 212	{ 665-702B	TR, KTC9012A-H
	{ 668N063A	IC, LA3161		{ 665-886D	TR, GS9023J
IC202	668N066A	IC, AN7156N	TR213	661N028A	TR, KTC9014A-C
IC411, 421	668-132A	IC, LB1405	TR214	{ 665-886D	TR, GS2053H
				{ 665-704B	TR, GS9023J
TRANSISTORS			TR215	{ 661N026A	TR, KTC9014A-C
TR1	662-601A	TR, MPS9426B		{ 665-702B	TR, GS9022J
TR 2, 3	665-819A	TR, KTC1923-R	TR216	661N028A	TR, GS9022I
TR4, 5	{ 661N007D	TR, GS9017H	TR217	{ 665-886D	TR, GS2053H
	{ 665-701B	TR, KTC9011A-H		{ 665-704B	TR, GS9023J
TR6, 7, 8	{ 661N007C	TR, GS9017G	TR401	{ 665-886B	TR, KTC9014A-C
	{ 665-701B	TR, KTC9011A-H		{ 665-704B	TR, GS9023H
TR9	{ 665-886D	TR, GS9023J	TR411, 431	{ 661-030B	TR, KTC9014A-C
	{ 665-704B	TR, KTC9014A-C		{ 665-702B	TR, GS9022I
TR101, 301	{ 661N025A	TR, GS9024K	TR412, 413	{ 665-886B	TR, KTC9012A-H
	{ 665-704B	TR, KTC9014A-C	432, 433	{ 665-704A	TR, GS9023H
TR102, 302	{ 661N004E	TR, GS9014J			TR, KTC9014A-B
	{ 665-704B	TR, KTC9014A-C	DIODES		
TR104, 304	{ 661N001F	TR, GS9011I	D1	654-618A	DIODE, 1S2236
	{ 665-704A	TR, KTC9014A-B	D2	652-015B	DIODE, KDS1555
TR105, 305	{ 661N003C	TR, GS9013H	D3, 4	651-001D	DIODE, FM2-1K261
	{ 665-703B	TR, KTC9013H	D5, 6, 7, 8	651-001C	DIODE, AM 1K60
TR201	{ 661N025A	TR, KS9024K	D10	654-622D	DIODE, UZ-4.7B
	{ 665-704B	TR, KTC9014A-C	D101, 102	652-015B	DIODE, KDS1555
TR203	{ 665-886D	TR, GS9023J	D202, 203	652-015B	DIODE, KDS1555
	{ 665-703C	TR, KTC9013A-I	D204	654-623F	DIODE, ZENER
TR204, 205, 206	{ 661-030B	TR, GS9022I	D205	652-015B	DIODE, KDS1555
	{ 665-702B	TR, KTC9012A-H	D206	652-005A	DIODE, 1N4001
TR207	{ 665-886D	TR, GS9023J	D210	652-015B	DIODE, KDS1555
	{ 665-704B	TR, KTC9014A-C	D211	654-612B	DIODE, ZENER ZPDIO
TR208	661N027B	TR, GS2013G			

SYMBOL NO.	PART NO.	DESCRIPTION
D401, 402	653-109A	LED, LN 05202P
D403	653-401B	LED, LN317RP-TUNING
D404, 405, 406	653-401A	LED, LN217RP-ST, REC, POWER
D501	652-021D	DIODE, M1-151R
D502	652-021C	DIODE, M1-151

SWITCHES

S1	556N045A	SWITCH-BAND
S2	552N073B	SWITCH-REC/PLAY
S3	556N044A	SWITCH-FUNCTION
S4	556N050B	SWITCH-REC MODE
S5	556N050C	SWITCH-LOUDNESS
S6	556N052A	SWITCH-Nor/CrO ₂
S7	552N077A	SWITCH-PHONO/LINE IN
S8	552-614A	SWITCH-RIF
S10	556-012A	SWITCH-POWER
S11	555N015B	SWITCH-MEMORY

COILS AND TRANSFORMERS

L1	635-020E	COIL, FM OSC
L2	635-602A	COIL, FM RF
L3	635-003B	COIL, FM OSC
L4	632N042B	COIL, MW/LW ANT (TSR-580)
	632N042A	COIL, MW/SW1 ANT (TSR-585)
L5	634N020F	COIL, SW ANT (TSR-580)
	634N020D	COIL, SW2 ANT (TSR-585)
L6	639-003L	COIL, PADDING 180μH
L7	634-015C	COIL, MW OSC
L8	634N037F	COIL, LW OSC (TSR-580)
	634N020B	COIL, SW1 OSC (TSR-585)
L9	634N020E	COIL, SW OSC (TSR-580)
	634N020C	COIL, SW2 OSC (TSR-585)
L10	636-006D	COIL, CHOKE 330μH

SYMBOL NO.	PART NO.	DESCRIPTION
L101, 301	639-602F	COIL, PEAKING 6.6 mH
L102, 302	639-003N	COIL, PADDING 3.3 mH
L103, 303	637-005B	COIL, PEAKING 33 mH
L201	634-036C	COIL, TAPE OSC
L202	639-003I	COIL, PADDING 4.7 μH
L204, 205	639-003I	COIL, PADDING 4.7 μH
T1	644-018F	TRANS, FM IF
T2	647-008C	DISCRIMINATOR
T3	647-008D	DISCRIMINATOR
T4	644-019C	TRANS, AM IF
T5	644-019D	TRANS, AM IF
T6	644-019G	TRANS, AM IF

VARIABLE RESISTORS

RV1	613N002F	VR, SEMI-FIXED 10KB
RV101, 301	613N002J	VR, SEMI-FIXED 100KB
RV103, 303	613N005H	VR, SEMI-FIXED 100KB
VR101, 301	611N053P	VR, 20KA-REC MODE
VR201	611N027G	VR, 100KA-TREBLE
VR202	611N072H	VR, 100KB-BASS
VR203	611N072F	VR, 20KA-VOLUME
VR204	611N089C	VR, 20KW-BALANCE
VR205	611N053P	VR, 20KA-MIX. MIC.

MISCELLANEOUS

VC1-4	622N048E	VARICON, POLY P2Z22BPT
BPF	616-011A	FILTER, BAND PASS
CF1	616-007A	FILTER, CERAMIC
LPF1, 2	616-009A	FILTER, LOW PASS
	572-042B	JACK-EXT. SP, MIC JACK
	572-034D	JACK-HEADPHONE
	572-002A	JACK-MIX. MIC.