



**STEREO CASSETTE DECK**  
**MODEL CS-702D**

<b>SECTION 1</b>	<b>SERVICE MANUAL</b> .....	<b>3</b>
<b>SECTION 2</b>	<b>PARTS LIST</b> .....	<b>23</b>
<b>SECTION 3</b>	<b>SCHEMATIC DIAGRAM</b> .....	<b>36</b>

---

---

SECTION 1

**SERVICE MANUAL**

TABLE OF CONTENTS

I.	TECHNICAL DATA .....	4
II.	DISMANTLING OF UNIT .....	5
III.	CONTROLS .....	6
IV.	PRINCIPAL PARTS LOCATION .....	7
V.	OPERATION OF AUTO STOP MECHANISM .....	8
VI.	MECHANISM ADJUSTMENT .....	10
	1. FLYWHEEL THRUST LOOSE PLAY ADJUSTMENT .....	10
	2. PINCH ROLLER PRESSURE MEASUREMENT .....	11
	3. ADJUSTMENT OF GAP BETWEEN THE PINCH ROLLER ARM AND STOPPER .....	11
	4. TAKE-UP TORQUE AT VARIOUS MODES .....	11
	5. TAPE SPEED ADJUSTMENT .....	11
VII.	HEAD ADJUSTMENT .....	11
	1. RECORDING/PLAYBACK HEAD AZIMUTH ALIGNMENT ADJUSTMENT .....	11
	2. HEAD ADJUSTMENT PRECAUTIONS .....	11
VIII.	AMPLIFIER ADJUSTMENT .....	12
IX.	DC RESISTANCE OF VARIOUS COILS .....	15
X.	CLASSIFICATION OF VARIOUS P.C BOARDS .....	15
	1. RELATION OF P.C BOARD TITLE AND IDENTIFICATION NUMBER .....	15
	2. COMPOSITION OF VARIOUS P.C. BOARDS .....	16

For basic adjustments, measuring methods, and operating principles, refer to GENERAL OPERATING PRINCIPLES AND ADJUSTMENTS.

## I. TECHNICAL DATA

TRACK SYSTEM	4 track 2 channel stereo system
TAPE	Philips type cassette tape
TAPE SPEED	1-7/8 ips
WOW AND FLUTTER	Less than 0.08% WRMS, Less than 0.2%
FREQUENCY RESPONSE	40 to 13,000 Hz $\pm$ 3 dB using LN tape 40 to 15,000 Hz $\pm$ 3 dB using CrO <sub>2</sub> (SA) tape
DISTORTION	Less than 1.5% using LN tape (1,000 Hz "0" VU) Less than 2.0% using CrO <sub>2</sub> (SA) tape (1,000 Hz "0" VU)
SIGNAL TO NOISE RATIO	Better than 50 dB using LN tape Better than 51 dB using CrO <sub>2</sub> (SA) tape (Measured via tape with peak recording level of +3 VU) Dolby NR Switch ON: Improves up to 10 dB above 5 kHz
ERASE RATIO	Better than 70 dB
BIAS FREQUENCY	85 kHz
HEADS	(2) One recording/playback head, one erase head
MOTOR	Electronically speed controlled DC motor
FF AND RWD TIME	120 seconds using a C-60 cassette tape
OUTPUT JACKS	Line (2): 410 mV ("0" VU), Required load impedance: More than 20 k ohms Phone (1): 50 mV/8 ohms
INPUT JACKS	Microphone (2): 0.3 mV/2.2 k ohms, Required microphone impedance: 600 ohms Line (2): 70 mV/100 k ohms
DIN JACK	Input: 0.3 mV/2.2 k ohms, Output: 410 mV Required load impedance: More than 20 k ohms
SEMI-CONDUCTORS	Transistors 18, Diodes 10, EETs 2, ICs 2
POWER REQUIREMENTS	CSA, UL and LA models: 120V, 60 Hz only CEE models: 220V, 50 Hz only Other models: 110V/120V/220V/240V, 50/60 Hz (Switchable)
DIMENSIONS	380 (W) x 157 (H) x 287 (D)mm (15 x 16.2 x 11.3")
WEIGHT	6.5 kg. (14.4 lbs)

\* For improvement purposes, specifications and design are subject to change without notice.

\* Noise reduction circuit made under license from Dolby Laboratories Inc. The word 'DOLBY' and the Double-D symbol are trademarks of Dolby Laboratories Inc.

## II. DISMANTLING OF UNIT

In case of trouble, etc. necessitating disassembly, please disassemble in the order shown in photographs. Reassemble in reverse order.

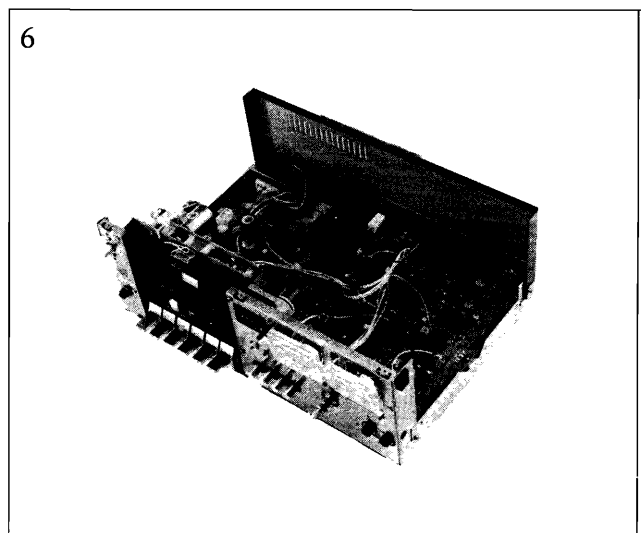
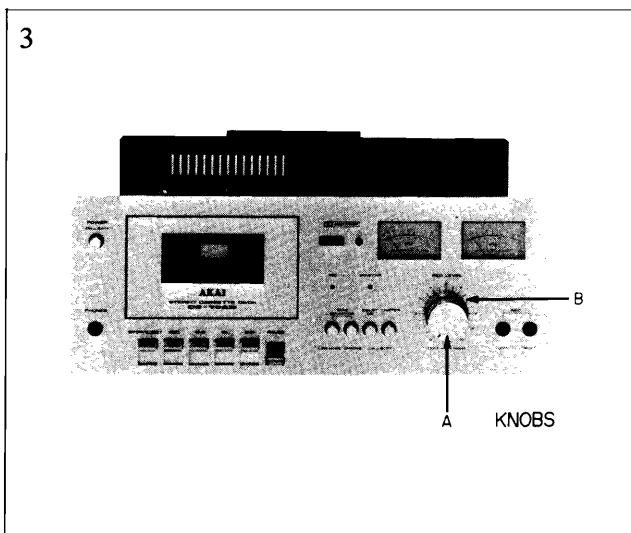
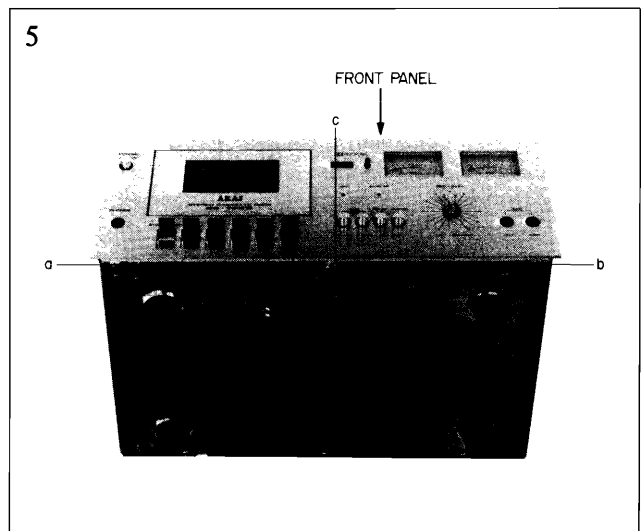
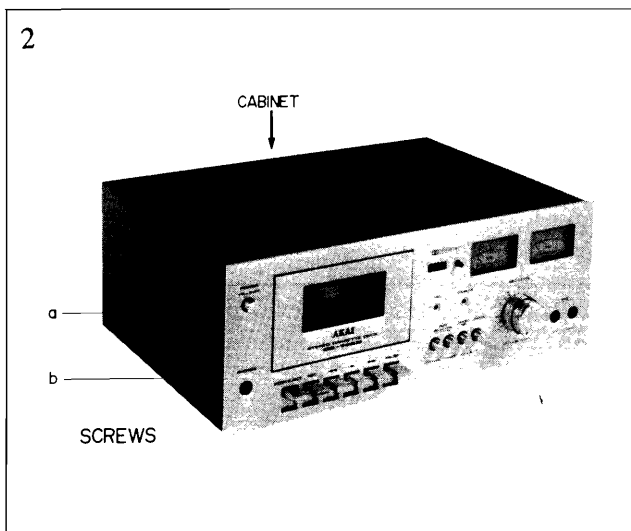
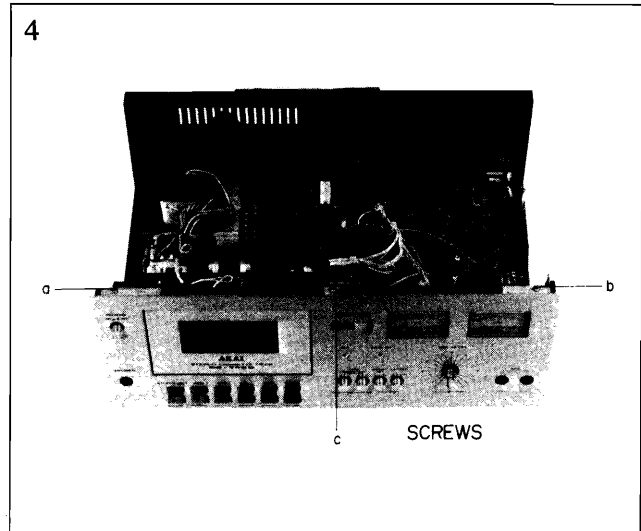
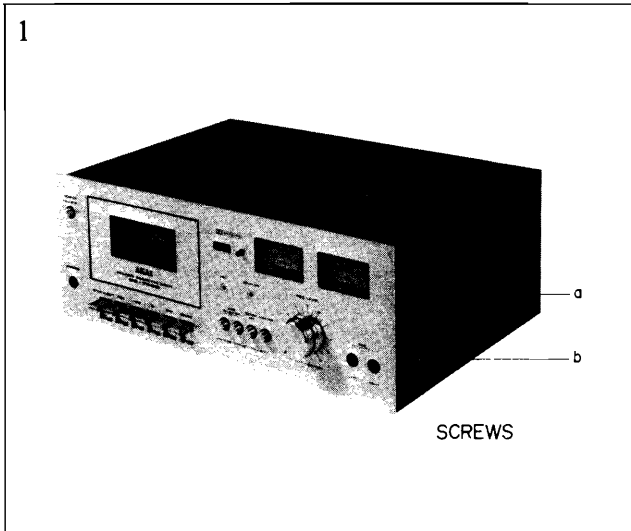

### III. CONTROLS

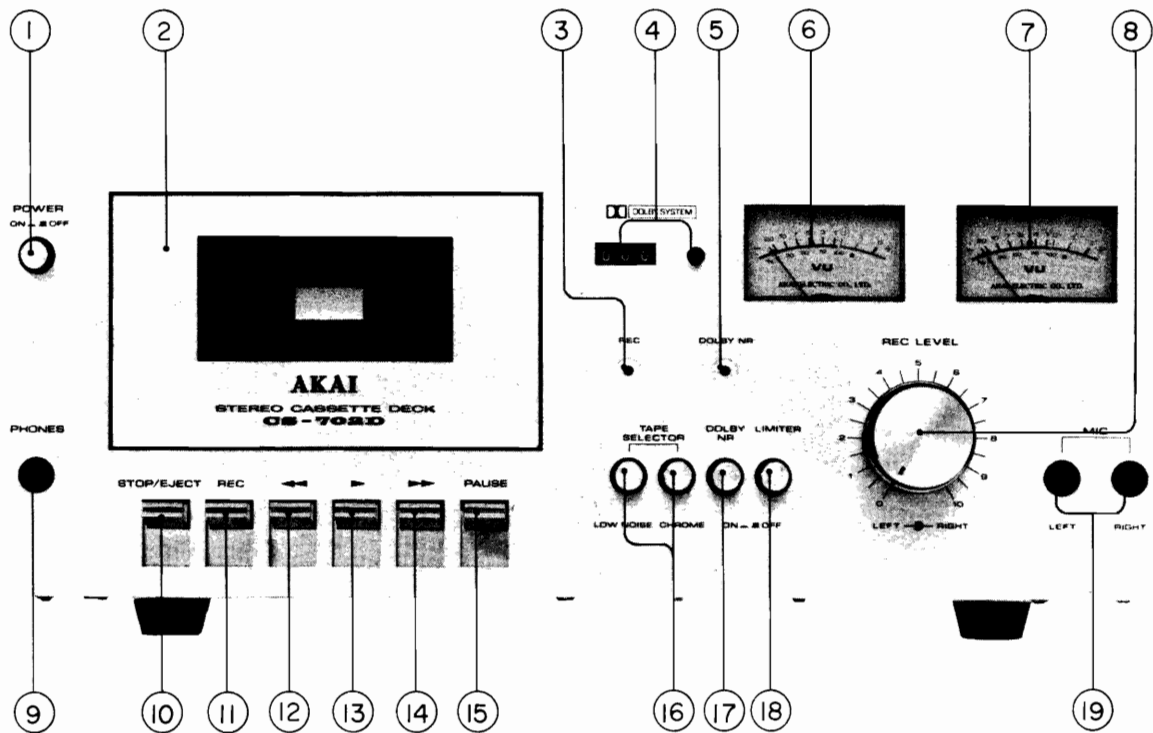

Fig. 1 Controls

1. POWER SWITCH
2. CASSETTE RECEPTACLE  
(with tape view window)
3. RECORDING INDICATOR LAMP
4. INDEX COUNTER AND RESET BUTTON
5. DOLBY N.R. INDICATOR LAMP
6. LEFT VU METER
7. RIGHT VU METER
8. RECORDING LEVEL CONTROLS  
(left and right)
9. HEADPHONE JACK
10. STOP/EJECT KEY
11. RECORDING (REC) KEY
12. REWIND KEY
13. PLAY KEY
14. FAST FORWARD KEY
15. PAUSE KEY
16. TAPE SELECTOR SWITCHES  
LOW NOISE CHROME
17. DOLBY N.R. SWITCH
18. LIMITER SWITCH
19. MICROPHONE JACKS  
(left and right)

# IV. PRINCIPAL PARTS LOCATION

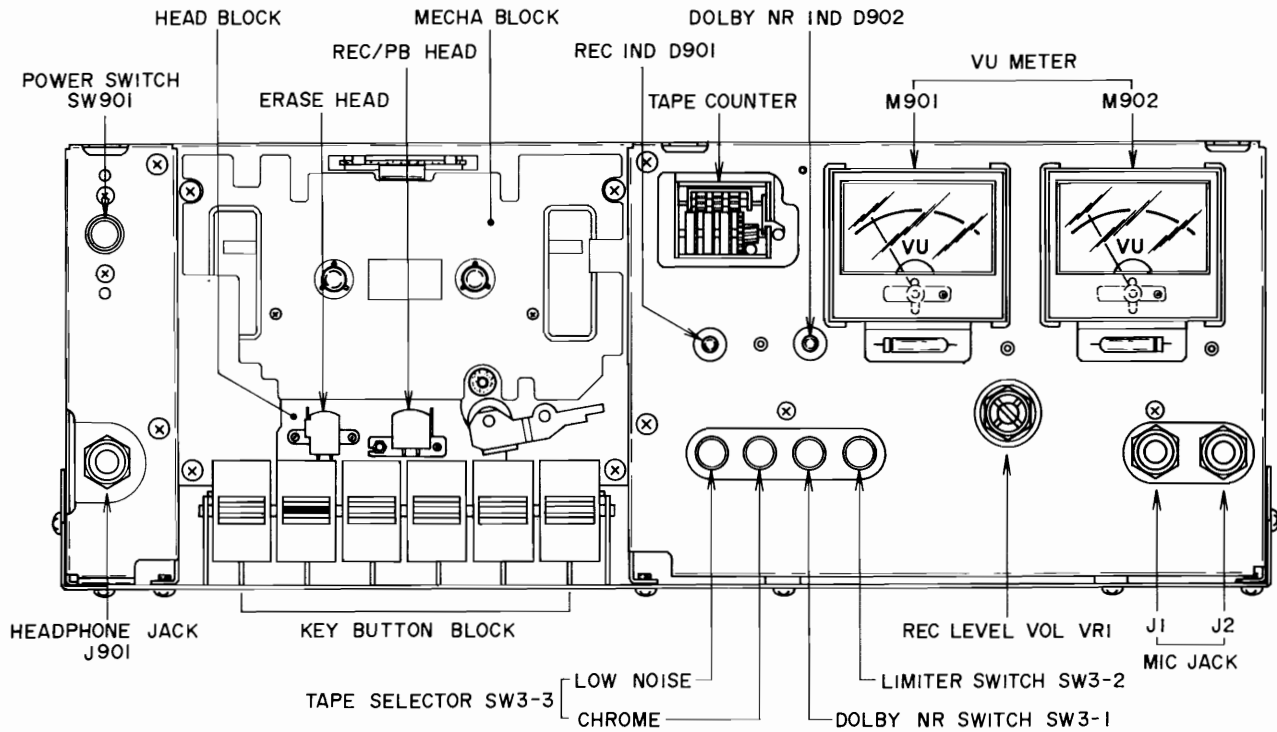

Fig. 2 Front View

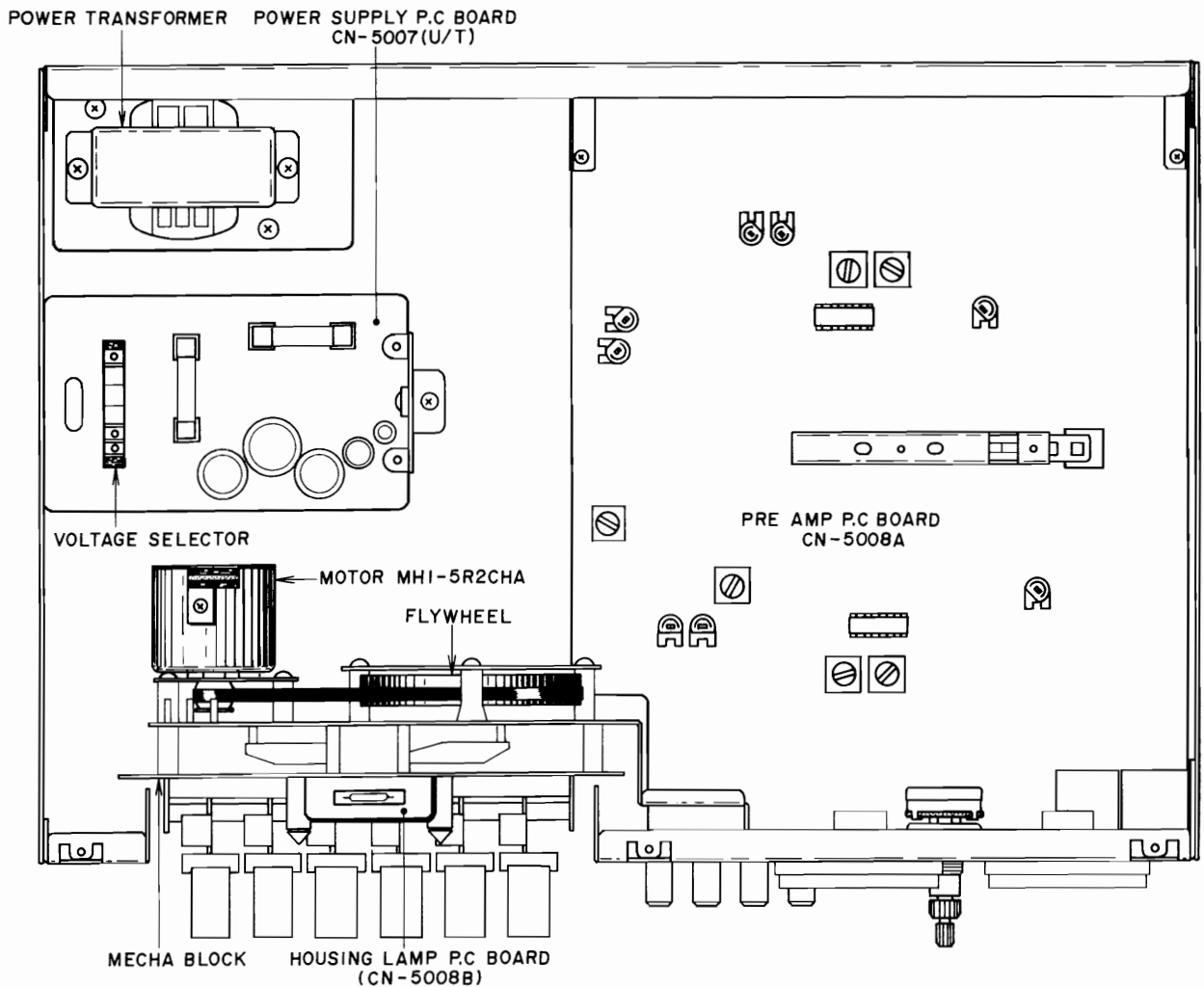

Fig. 3 Top View

# V. OPERATION OF AUTO STOP MECHANISM

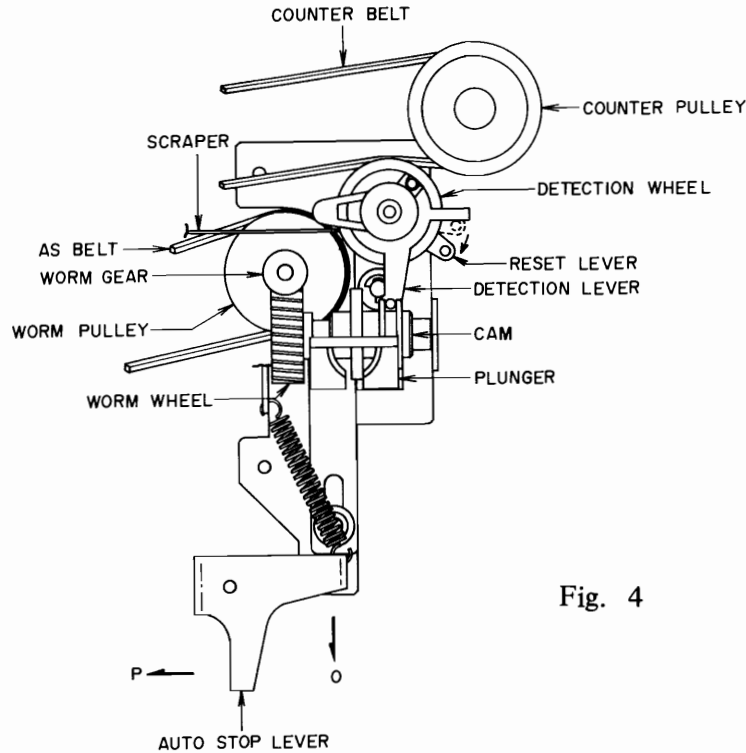

Fig. 4

1. When Play, Rewind or Fast Forward key is depressed, the lever functioning in combination with the depressed key causes the motor switch SW904 to go on, permitting the tape deck motor to start rotating.
2. At the same time, the lever functioning in combination with the depressed key allows the reset lever to move downward as illustrated in Fig. 4.
3. When the motor starts rotating, the worm pulley is driven by the AS belt as shown in Fig. 4, thereby rotating the worm gear to turn the cam. On the other hand, the counter belt permits the detection wheel to rotate.
4. Auto stop operation during Play mode.

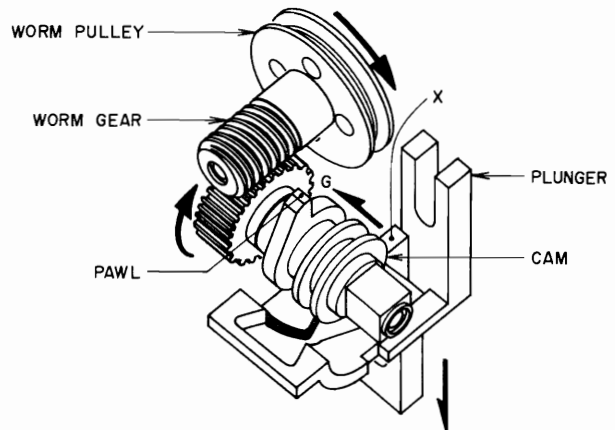

Fig. 6(a)

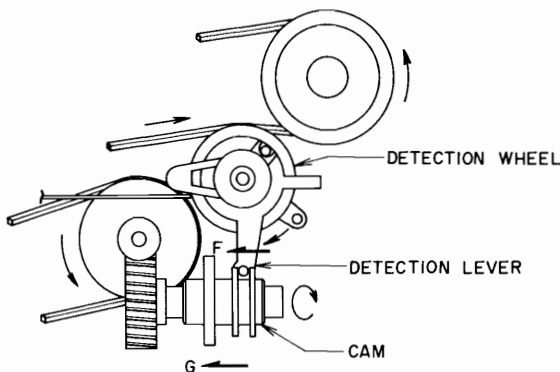

Fig. 5

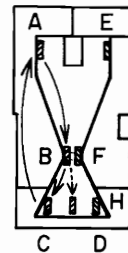

Fig. 6(b) Movement of the pawl mounted on the cam when viewing the plunger from above.

- 1) Because the detection wheel is turning clockwise as indicated in Fig. 5, friction between the detection wheel and the detection lever causes constant pressure to be exerted on the detection lever in the direction of the arrow F, while the direction lever exerts force F on the cam in the direction of the arrow G.



- 2) While the revolution of the worm pulley permits the worm gear and the cam to rotate, the pawl mounted on the cam as illustrated in Fig. 6 revolves inside the plunger (i.e. the part colored in red), while receiving force G as explained above.
- 3) Fig. 6(b) illustrates the motion of the pawl mounted on the cam with the plunger viewed from above. Since force is applied to the pawl in the direction of G as indicated in Fig. 5, the pawl rotates on the left hand of the plunger, in order of A, B and C.
- 4) When the tape transport stops, the detection wheel driven by the counter belt stops rotating and the force in the direction of the arrow G which was exerted on the cam as shown in Fig. 5 ceases.  
In this case, the motor continues rotating, keeping the worm pulley turning. Therefore, when the cam continues to rotate with the pawl shifted from A to B position, the pawl does not move in the direction of C but turns in the center of the plunger as shown in Fig. 6(b).
- 5) As the rotation of the cam in the center of the plunger proceeds further, the pawl of the cam engages with part X indicated in Fig. 6(a), thereby pushing the plunger downward.
- 6) Shifted in a downward direction, the plunger removes the auto stop lever in the direction of P as indicated in Fig. 4 to release the Play mode and to thus set the tape deck to the Stop mode.
5. Auto stop operation during Fast Forward mode is performed in the same way as during Play mode.
6. Auto stop operation during Rewind mode

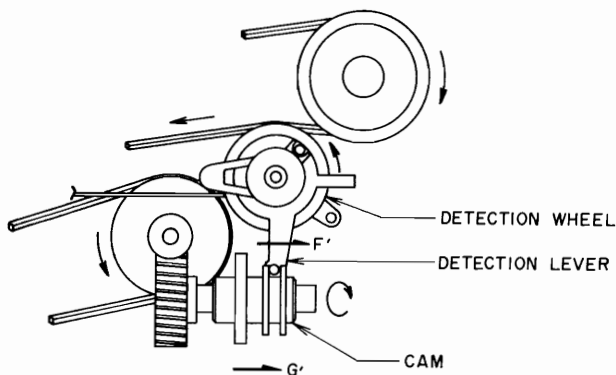

Fig. 7

- 1) Because the detection wheel is turning counter-clockwise as indicated in Fig. 7, friction between the detection wheel and the detection lever causes constant pressure to be exerted on the detection lever in the direction of arrow F', while the detection lever exerts force F' on the cam in the direction of arrow G'.
- In this case, since the direction of tape transport is opposite to that in the aforementioned operation during Play or Fast Forward mode, the auto stop operation is performed in exactly the opposite way.

- 2) The cam rotates, exerting force on the pawl of the cam in the direction of G' as indicated in Fig. 7 causing the pawl to rotate on the right hand of the plunger. The cycle of E, F and H positions are repeated as illustrated in Fig. 6(b).
- 3) When tape transport stops, the detection wheel driven by the counter belt ceases rotating, and the force in the direction of the arrow G' which was exerted on the cam as shown in Fig. 7 ceases. In this case, the motor continues rotating, keeping the worm pulley turning. Therefore, when the cam continues to rotate with the pawl shifted from E to F position, the pawl does not move in the direction of C but turns in the center of the plunger.
- 4) As the rotation of the cam in the center of the plunger proceeds further, the pawl of the cam engages with part X indicated in Fig. 6(a), thereby pushing the plunger downward.
- 5) Shifted in a downward direction, the plunger removes the auto stop lever in the direction of P as indicated in Fig. 4 to release the Rewind mode and to thus set the tape deck to the Stop mode.
7. Operation in the Pause mode

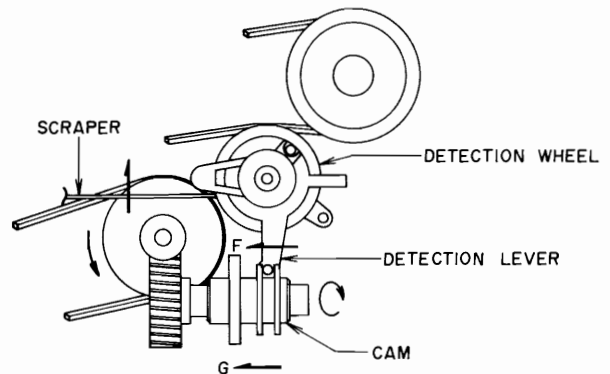

Fig. 8

- 1) When Pause key is depressed in the Play mode, tape transport stops, and the detection wheel ceases rotating. This sets the tape deck in the same condition as when the end of the tape is reached, so that the auto stop mechanism is actuated. However, depressing Pause key causes the scraper to push the detection lever in the direction of G as illustrated in Fig. 8. As a result, the cam is constantly pushed in the direction of G, permitting the auto stop mechanism to function in the same way as in the same way as in the Play or Fast Forward mode and thus preventing the auto stop operation from being executed.
- 2) If Pause Key is depressed in the Fast Forward or Rewind mode, the scraper permits the detection lever to push the cam in the direction of G. Therefore, the auto stop operation is not performed even when the tape transport is stopped.

## VI. MECHANISM ADJUSTMENT

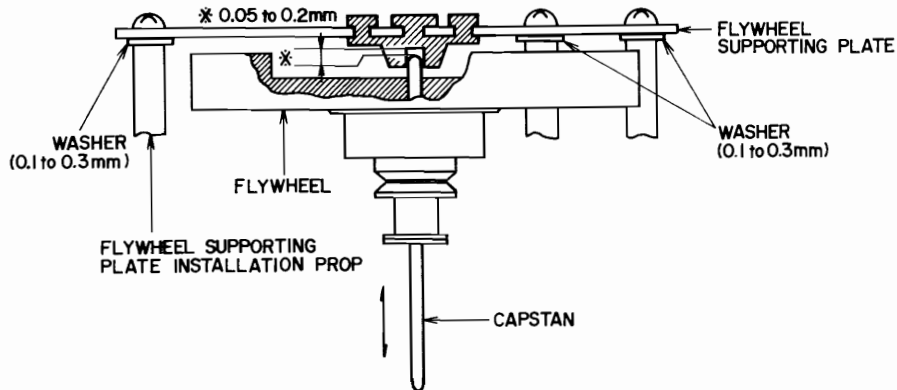

Fig. 9 Flywheel Thrust Loose Play Adjustment  
(Prior to serial No. 20317-0500)

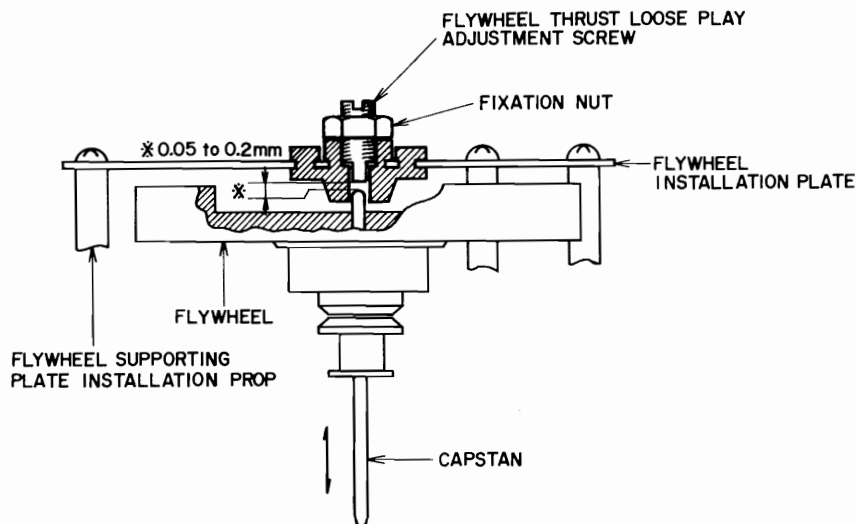

Fig. 10 Flywheel Thrust Loose Play Adjustment  
(from serial No. 20420-0001)

Note: Because flywheel loose play adjustment method differs according to serial no, make adjustment only after checking the serial number.

### 1. FLYWHEEL THRUST LOOSE PLAY ADJUSTMENT

- 1) Prior to Serial No. 20317-0500 (Refer to Fig. 9)  
Adjust by inserting 0.1 to 0.3 mm washers in the places designated in the figure so that when the flywheel is moved as indicated by the arrow marks, loose play is within 0.05 to 0.2 mm.  
\* When inserting washers, be sure to use washers of the same thickness and insert in all three places.
- 2) From Serial No. 20420-0001 (Refer to Fig. 10)  
Adjust flywheel thrust loose play adjustment screw so that when the flywheel is moved as indicated by the arrow marks, loose play is within 0.05 to 0.2 mm'  
\* Tighten fixation nut following adjustment.

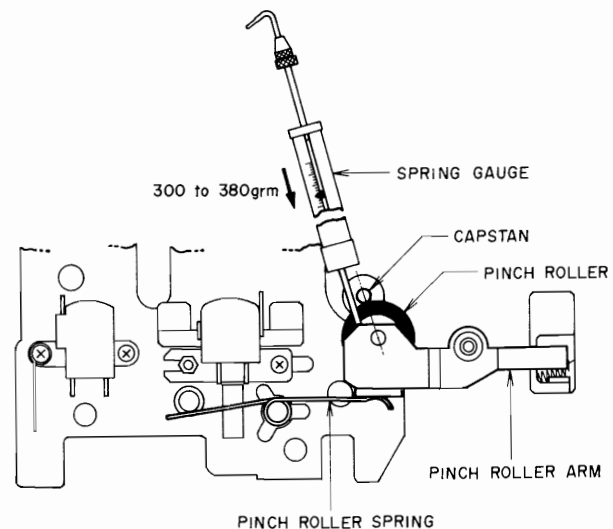

Fig. 11 Pinch Roller Pressure Measurement

## 2. PINCH ROLLER PRESSURE MEASUREMENT (Refer to Fig. 11)

At playback mode, with a 500g spring gauge, push the pinch roller arm downward in direction of the dotted line in the figure and gently release. Take a reading of the spring gauge scale just as the pinch roller contacts the capstan and begins to rotate.

Proper pinch roller pressure: 300 to 380 grams

If not within specifications, replace pinch roller spring.

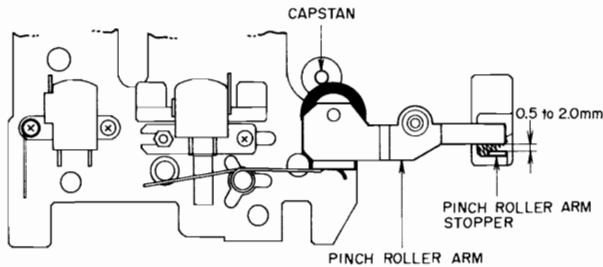

Fig. 12 Gap between pinch roller arm and stopper

## 3. ADJUSTMENT OF GAP BETWEEN THE PINCH ROLLER ARM AND STOPPER (Refer to Fig. 12)

Adjust by bending the pinch roller arm stopper so that a 0.5 to 2.0 mm gap is definitely obtained between the pinch roller arm and the pinch roller arm stopper when the deck is set to play mode.

## 4. TAKE-UP TORQUE AT VARIOUS MODES

Playback mode: 40 to 60 gram-cm

Fast Forward mode: 70 to 130 gram-cm

Rewind mode: 70 to 130 gram-cm

In case specified take-up torque cannot be attained,  
Playback mode: Replace Take-up reel table Block Comp.

Fast Forward

or Reqid mode: Replace entire supply reel assembly or Middle Lever Block Comp.

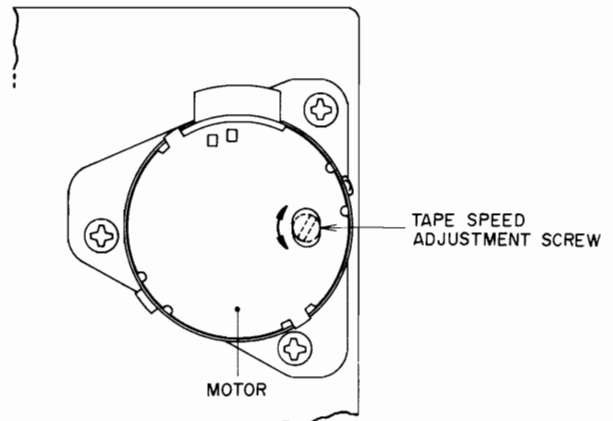

Fig. 13 Tape speed adjustment

## 5. TAPE SPEED ADJUSTMENT (Refer to Fig. 13)

Playback a 1,000 Hz pre-recorded test tape and adjust tape speed adjustment screw to obtain a tape speed of 1,000 Hz  $\pm 2\%$ .

# VII. HEAD ADJUSTMENT

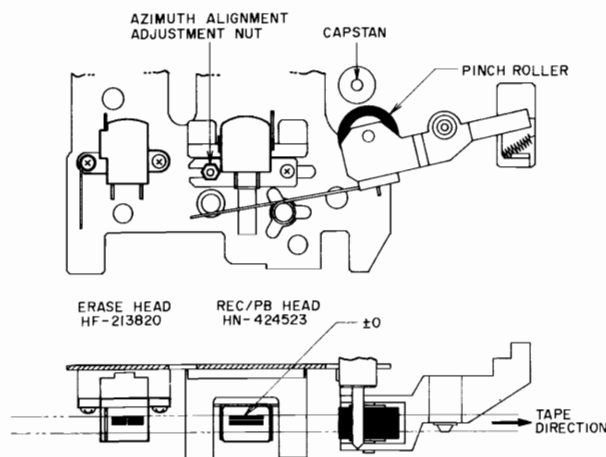

Fig. 14 Head Adjustment

## 1. RECORDING/PLAYBACK HEAD AZIMUTH ALIGNMENT ADJUSTMENT

Playback a 10 kHz pre-recorded azimuth alignment cassette test tape and adjust recording/playback head azimuth alignment adjustment nut to obtain maximum output.

## 2. HEAD ADJUSTMENT PRECAUTIONS

\* Be sure to clean the heads prior to adjustment.

\* As the use of a magnetized driver or other magnetized tools in the vicinity of the heads will cause the heads to become magnetized, use only demagnetized tools for head adjustment.

# VIII AMPLIFIER ADJUSTMENT

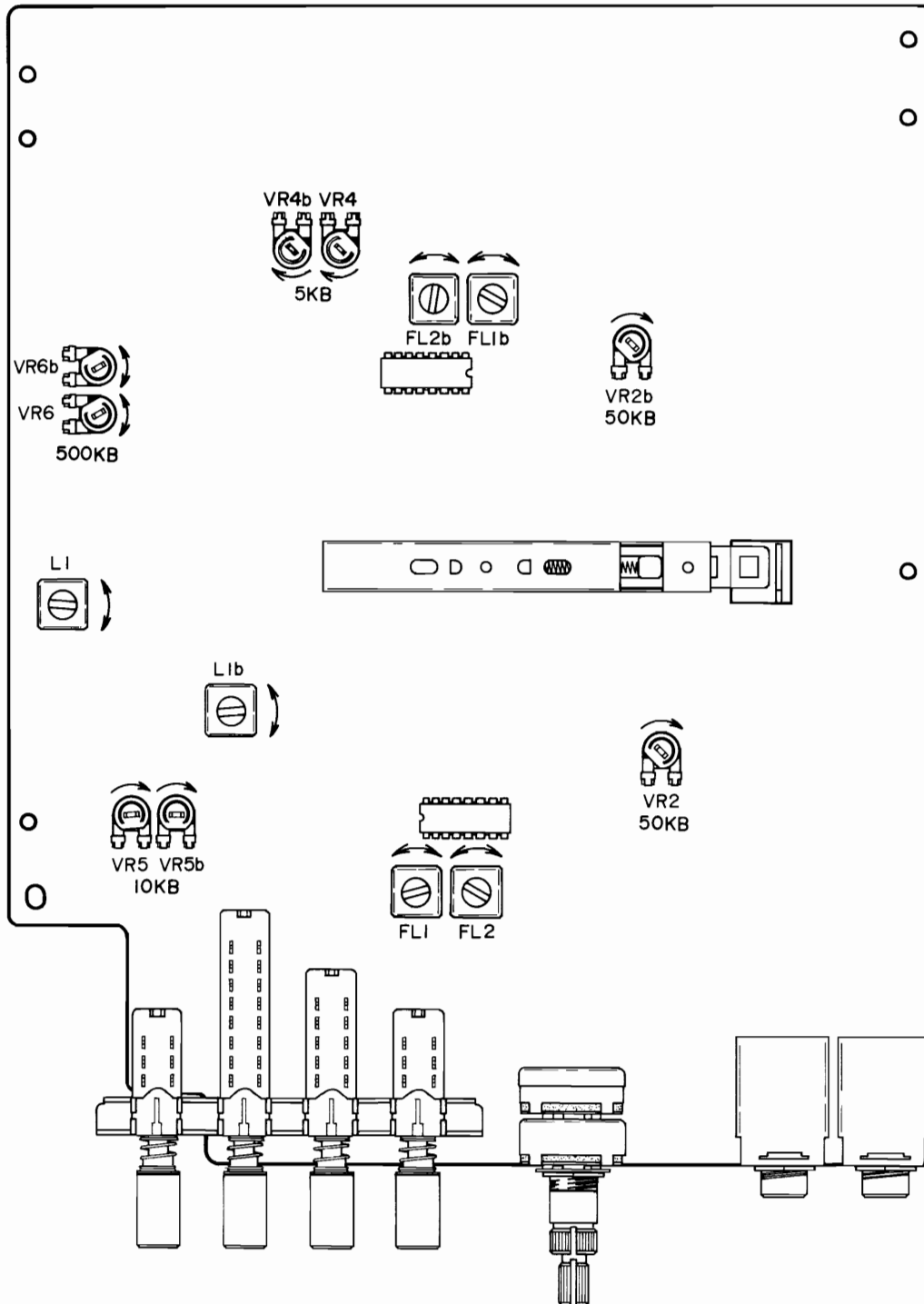

Fig. 15 Pre Amp P.C Board CN-5008A

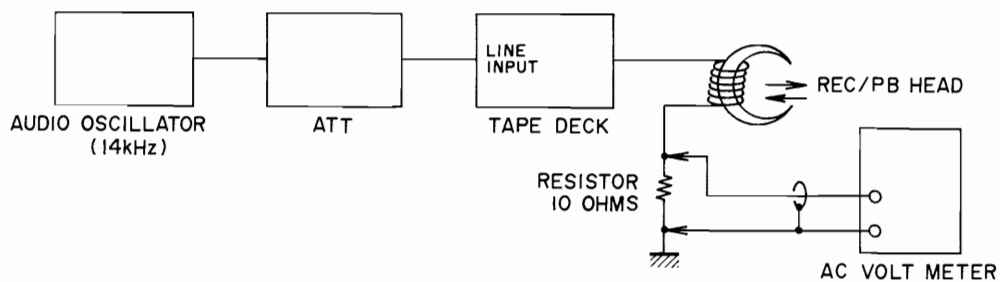
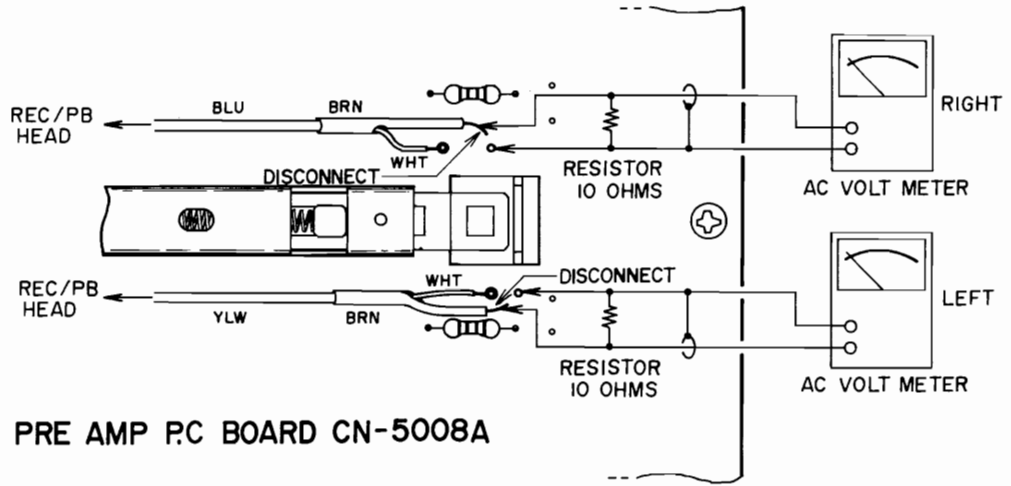
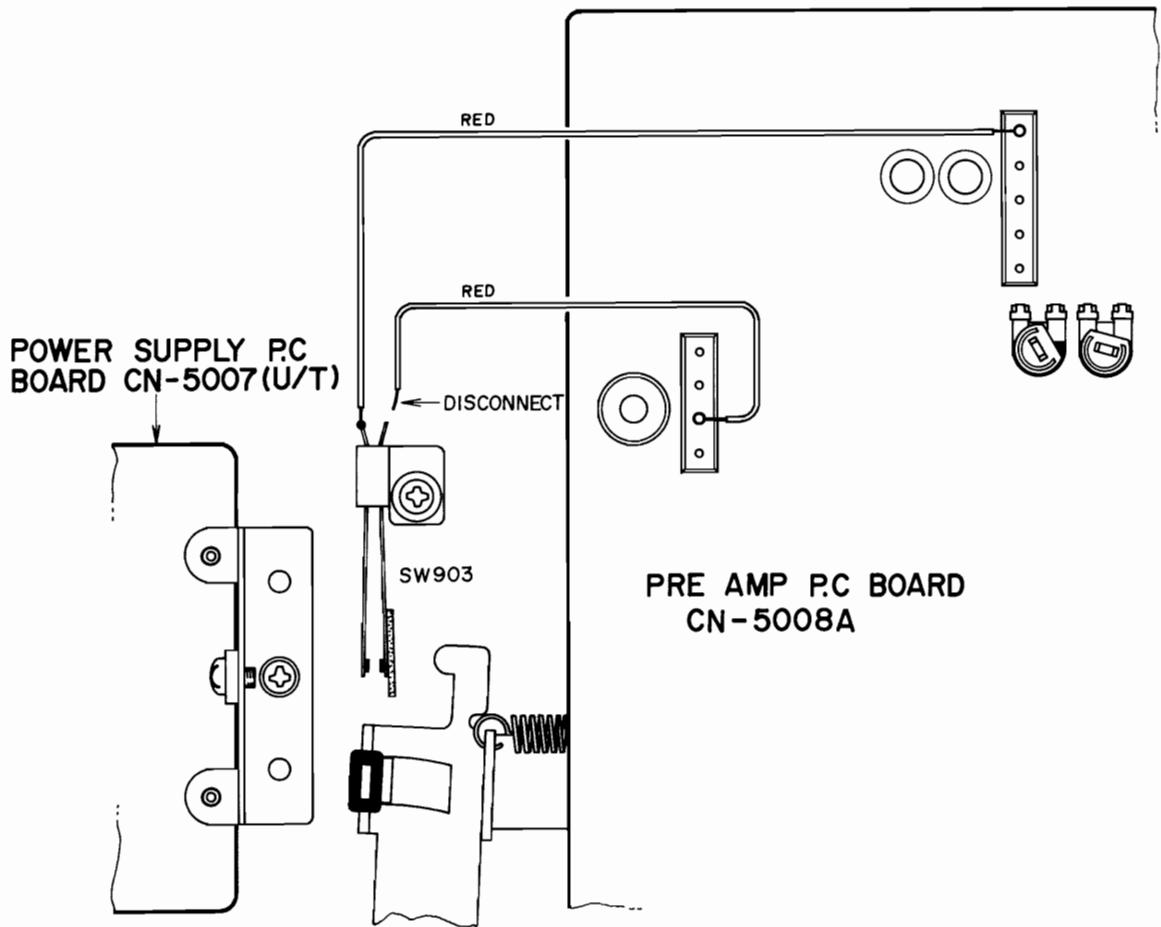

Fig. 16 Instrument Connections



(a)



(b)

Fig. 17 Rec Peaking Adjustment

Step	Adjustment Item	Test Tape Supply Signal	Mode	Adjustment Point	Result	Remarks
1	Playback level adjustment	333 Hz, 0 VU Test Tape	Play	VR2, 50 k $\Omega$	-5.5 $\pm$ 0.5dBm (410 mV)	
2	VU Meter Sensitivity adjustment	333 Hz, 0 VU Test Tape	Play	VR4, 5 k $\Omega$	0 VU indication	
3	Recording level adjustment	Low noise blank tape, 1,000 Hz, 0 VU recording	Rec/Play	VR5, 10 k $\Omega$	-5.5 $\pm$ 0.5dBm (410 mV)	Refer to Note 6)
4	Frequency response adjustment	Low noise blank tape, 1,000 Hz, 10,000 Hz, -20 VU recording	Rec/Play	VR6, 500 k $\Omega$	1,000 Hz to 10,000 Hz flat response	Refer to Note 6)
5	Rec peaking adjustment	14 kHz from an oscillator	Rec	L1 3.3 mH	Maximum AC voltmeter indication	Refer to Note 7) and Figs. 16, 17
6	Bias leak adjustment		Rec	FL2	Minimum AC voltmeter indication	
7	19 kHz filter adjustment	19 kHz from an oscillator	Rec	FI1	Minimum AC voltmeter indication	Refer to Note 8)

Chart 1

- NOTES:
- 1) Set Tape Selector to Low Noise.
  - 2) Set Dolby N.R. Switch to OFF.
  - 3) Set Limiter Switch to OFF.
  - 4) After Recording Level and Frequency Response Adjustments have been made with Low Noise Tape, confirm with Chrome tape only.
  - 5) Because each of these adjustments are vital to perfect Dolby N.R. circuit operation, be sure that they are carried out with as little error as possible.
  - 6) Use the following cassette measuring tape:  
Low Noise Tape: Fuji FL C-60  
Chrome Tape: TDK SA C-60, BASF Chromdioxid C-60
  - 7) Stop recording bias oscillator while making Rec Peaking Adjustment (Refer to Figs. 16, 17)
  - 8) Unless the core is moved intentionally this adjustment is not necessary.

## IX. DC RESISTANCE OF VARIOUS COILS

---

Part	Designation	DC Resistance
Recording/Playback Head	MH-424523	170 ohms $\pm$ 20%
Erase Head	HF-213822	4.5 ohms

Chart 2

## X. CLASSIFICATION OF VARIOUS P.C BOARDS

---

### 1. RELATION OF P.C BOARD TITLE AND IDENTIFICATION NUMBER

P.C Board	Number of P.C Board
Pre Amp P.C Board	CN-5008A
Housing Lamp P.C Board	CN-5008B
Headphone P.C Board	CN-5008C
Power Supply P.C Board (U/T)	CN-5007
Power Supply P.C Board (others)	CN-5006
VU Lamp P.C Board	CN-5012

Chart 3

## 2. COMPOSITION OF VARIOUS P.C BOARD

### 1) PRE AMP P.C BOARD CN-5008A & HEADPHONE P.C BOARD CN-5008C

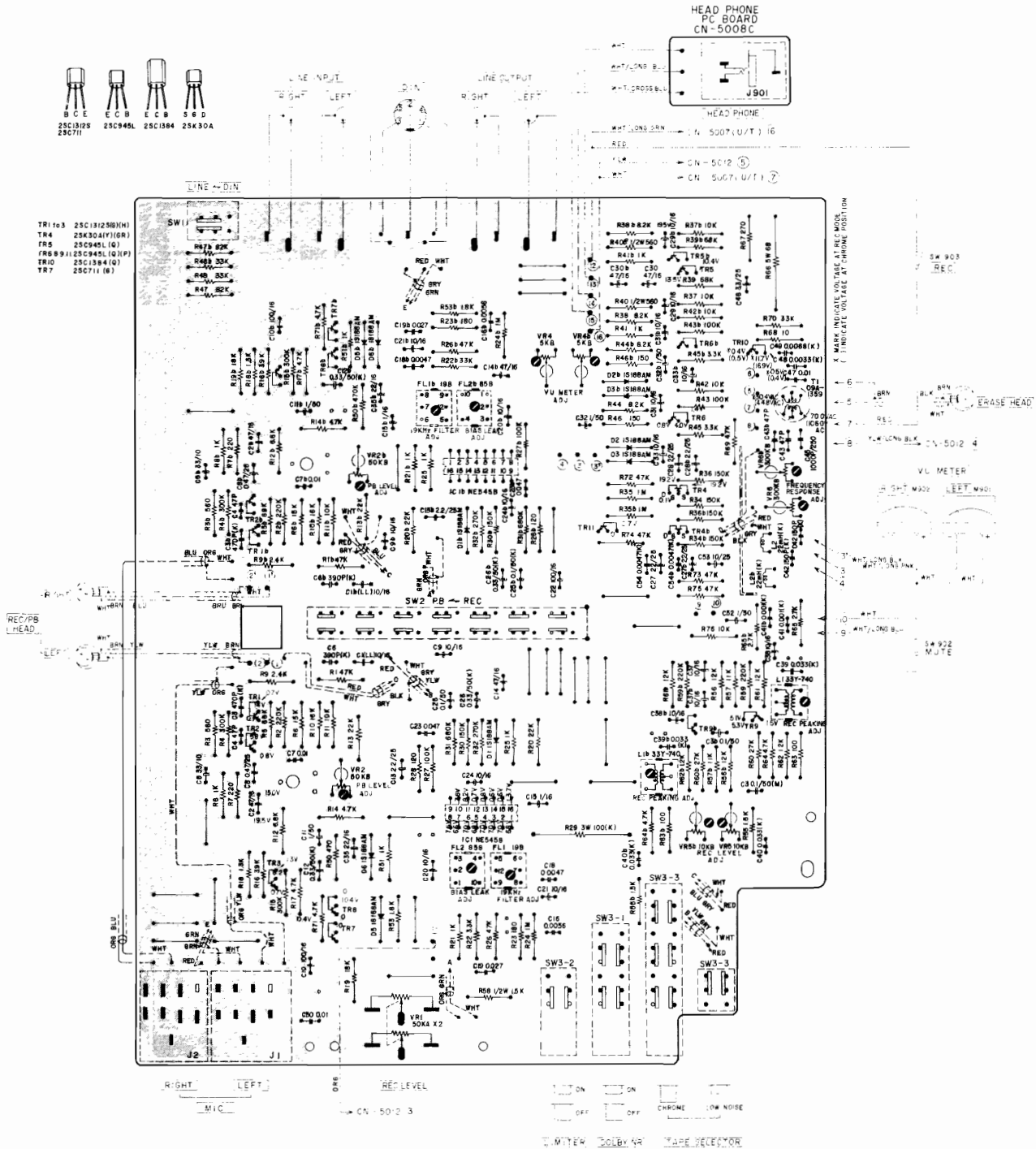



2) POWER SUPPLY P.C BOARD CN-5007 (U/T) &  
HOUSING LAMP P.C BOARD CN-5008B

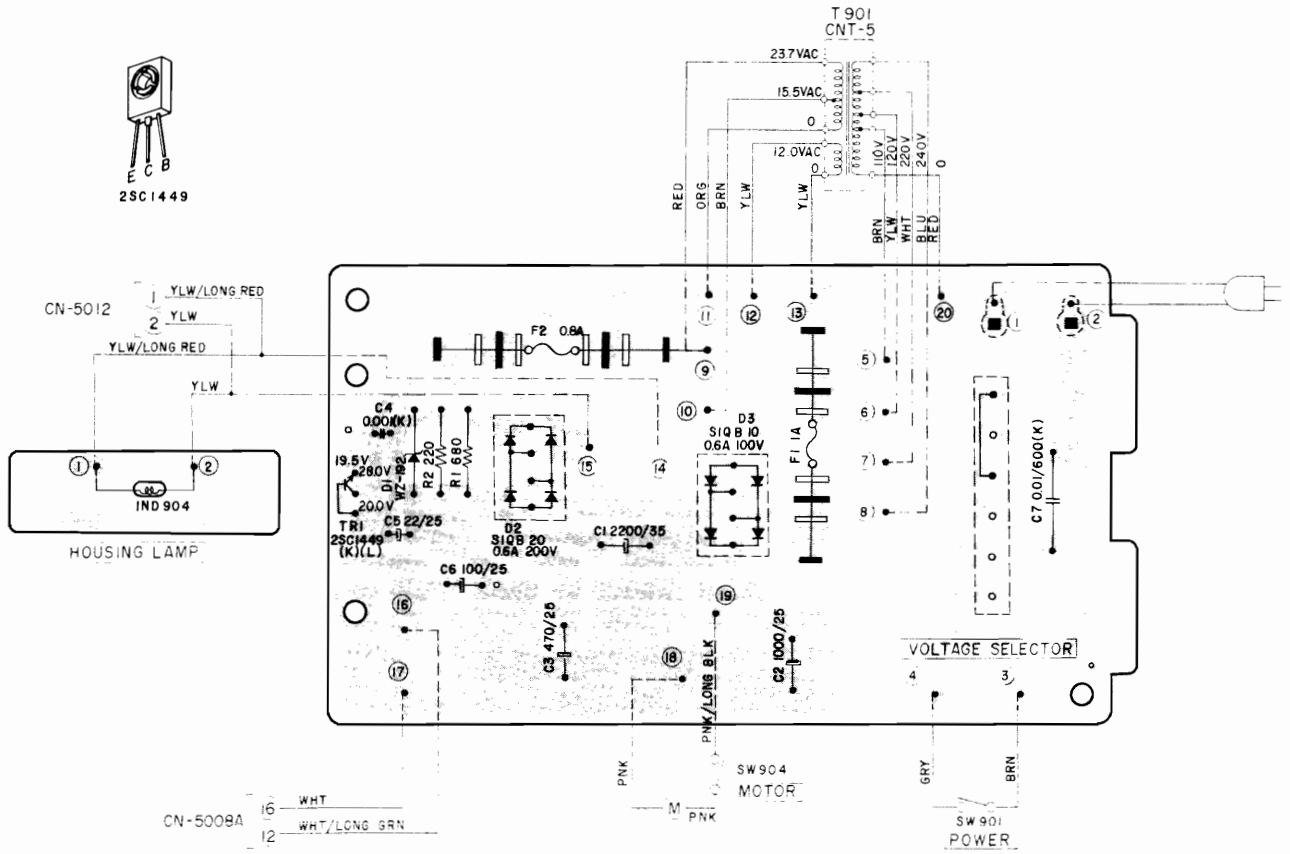

### 3) POWER SUPPLY P.C BOARD CN-5006 (JPN/CSA/AAL)

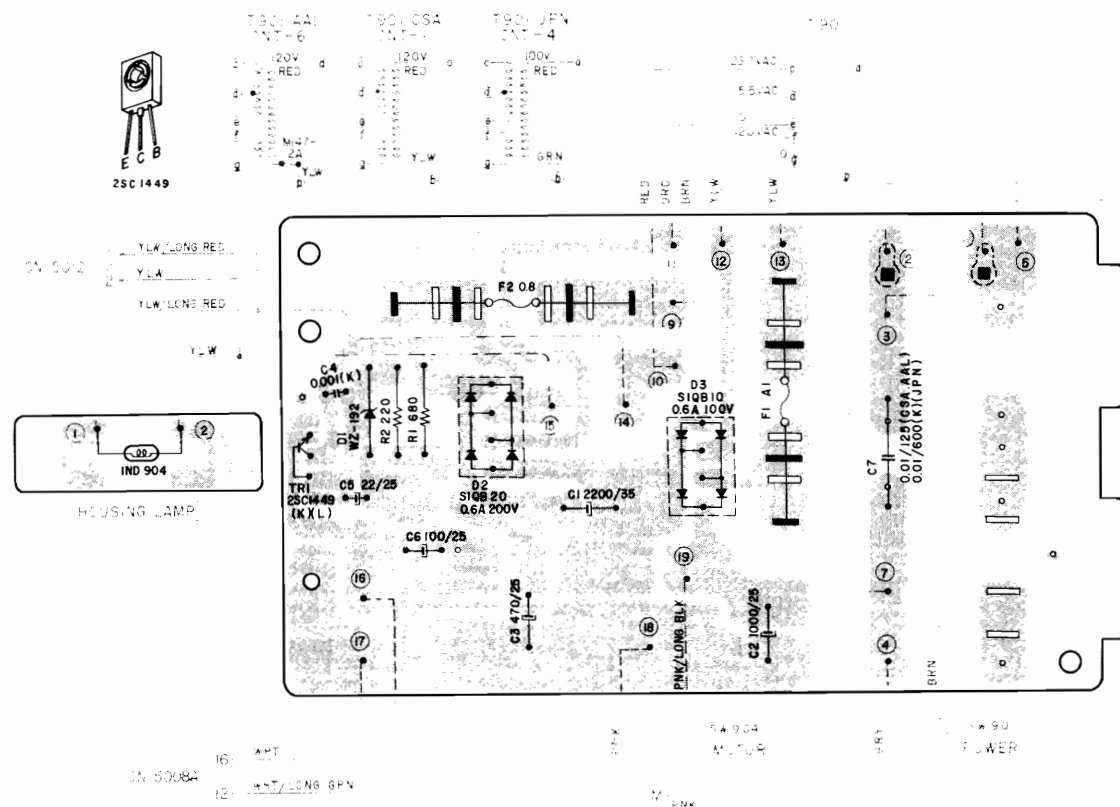

### 4) POWER SUPPLY P.C BOARD CN-5006 (CEE)

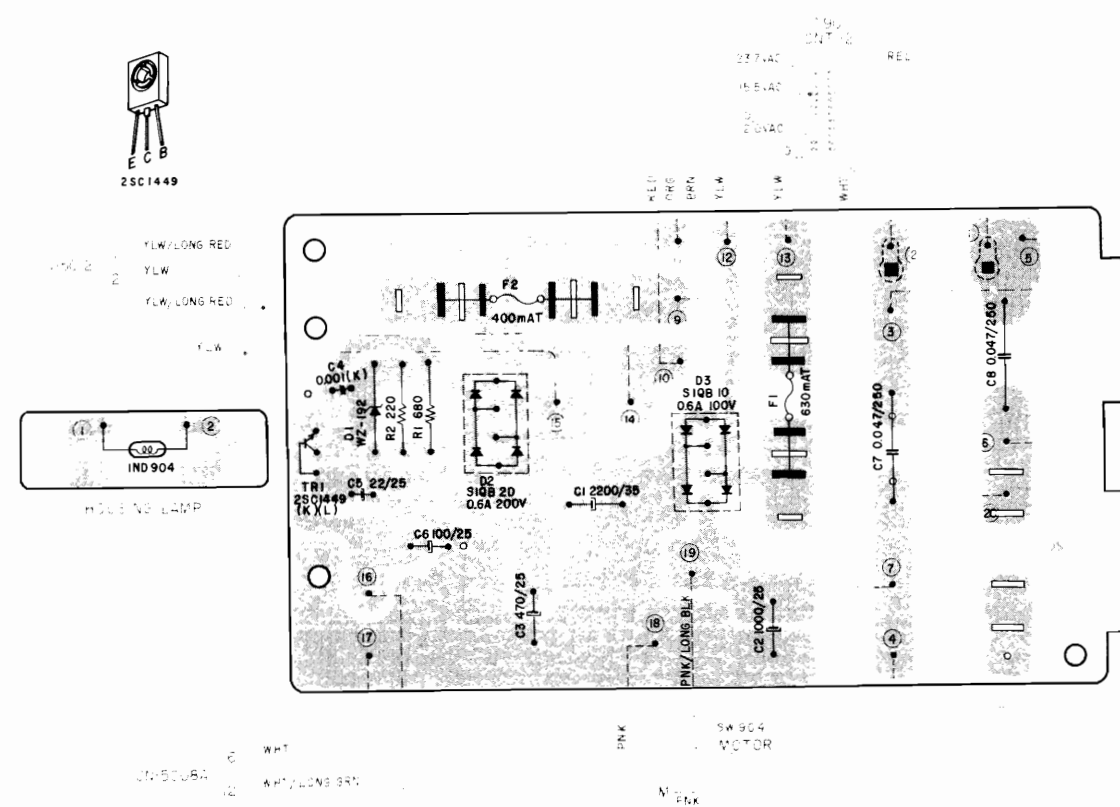









---

SECTION 2

**PARTS LIST**

TABLE OF CONTENTS

1.	RECOMMENDED SPARE PARTS LIST .....	25
2.	HEAD BASE BLOCK .....	26
3.	FLYWHEEL/MOTOR BLOCK .....	27
4.	MECHA FRAME BLOCK .....	28
5.	P.C BOARDS .....	30
	(1) PRE AMP P.C BOARD (CN-5008A) BLOCK .....	30
	(2) POWER SUPPLY P.C BOARD (CN-5007)(CN-5006) BLOCK. .	30
	(3) VU LAMP P.C BOARD (CN-5012) BLOCK .....	30
6.	AMP ASSEMBLY BLOCK .....	31
7.	FINAL ASSEMBLY BLOCK .....	33
8.	LIST OF INTERCHANGEABLE SEMICONDUCTORS .....	34
	INDEX .....	35

Resistor and Capacitor which is not listed in this parts list, please refer to  
COMMON LIST FOR SERVICE PARTS.

## HOW TO USE THIS PARTS LIST

1. This parts list is compiled by various individual blocks based on assembly process.
2. When ordering parts, please describe parts number, serial number, and model number in detail.
3. How to read list.

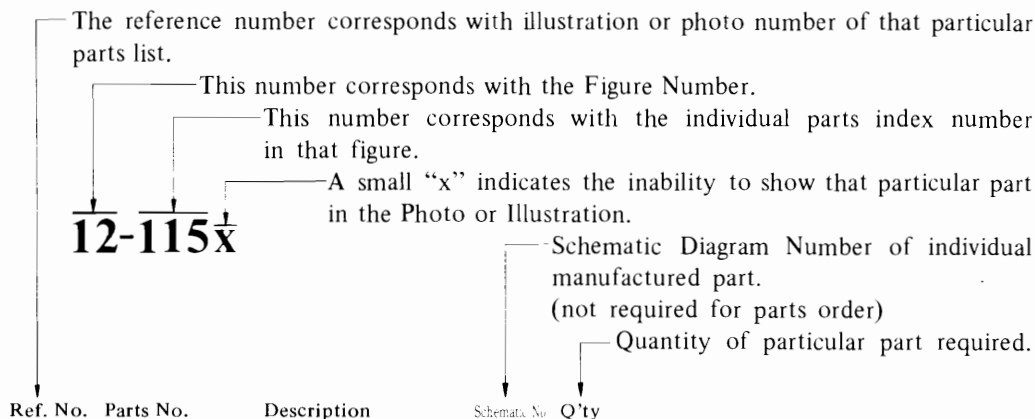

### FLYWHEEL BLOCK #13

12-115x	800425	Flywheel Block Assy. Comp.	RDG #13	1
12-116	244506	Flywheel Only	RD 233	1
12-117x	244754	Felt, Flywheel	RD 275	1
12-118	251324	Main Metal Case	RD 236	1
12-119	253080	Main Metal	RD 237	1

4. The symbol numbers shown on the P.C. Board list can be matched with the Composite Views of components of the Schematic Diagram or Service Manual.
5. The indications of Resistors and Capacitors in the photos of P.C. Board are being eliminated.
6. The shape of the parts and parts name, etc. can be confirmed by comparing them with the parts shown on the Electrical Parts Table of P.C. Board.
7. Both the kind of part and installation position can be determined by the Parts Number. To determine where a parts number is listed, utilize Parts Index at end of Parts List.  
It is necessary first of all to find the Parts Number. This can be accomplished by using the Reference Number listed at right of parts number in the Parts Index. (meaning of ref. no. outlined in Item 3 above).
8. Utilize separate "Price List for Parts" to determine unit price. The most simple method of finding parts Price is to utilize the reference number.

### CAUTION:

1. When placing an order for parts, be sure to list the parts no., model no., and description. There are instances in which if any of this information is omitted, parts cannot be shipped or the wrong parts will be delivered.
2. Please be careful not to make a mistake in the parts no. If the parts no. is in error, a part different from the one ordered may be delivered.
3. Because parts number and parts unit supply in the Preliminary Service Manual (Basic Parts List) may be partially changed, please use this parts list for all future reference.



## 1. RECOMMENDED SPARE PARTS LIST

Because, if the parts listed below are on hand, almost any repair can be accomplished, we suggest that you stock these Recommended Spare Parts Items.

Parts No.	Description	Note
BA274061	Power Supply P.C Board Comp. CN-5007	U/T
BA274116	Power Supply P.C Board Comp. CN-5006	JPN
BA274105	Power Supply P.C Board Comp. CN-5006	AAL
BA274094	Power Supply P.C Board Comp. CN-5006	CSA
BA274083	Power Supply P.C Board Comp. CN-5006	CEE
BA268492	Power Supply P.C Board Comp. CN-5006	BEAB
BA274004	Pre Amp P.C Board Comp. CN-5008A	
BD273870	Front Panel Block Comp.	
BD300297	Lid Case Comp.	
BF274217	Flywheel Block Comp.	
BL274263	Pinch Roller Arm Block Comp. CN-9708	
BL282510	Middle Lever Block Comp.	
BM302788	Motor Block Comp.	
BR282475	Take-up Reel Table Comp.	
BR282497	Supply Reel Table Comp.	
BT283004	Power Trans. CNT-1	CSA
BT283015	Power Trans. CNT-2	CEE
BT283026	Power Trans. CNT-3	BEAB
BT283037	Power Trans. CNT-4	JPN
BT283048	Power Trans. CNT-5	U/T
BT301773	Power Trans. CNT-6	AAL
BZ282881	Auto Stop Comp. CN-3014	
BD249377	LED GL-3AR1	D901 (CN-5012)
ED249581	Silicon Diode SIQB20 0.6A 200V	D2 (CN-5007/5006)
ED284095	Silicon Diode SIQB10 0.6A 100V	D3 (CN-5007/5006)
ED283138	LED GL-32PG	D902 (CN-5012)
ED498150	Zener Diode WZ-192	D1 (CN-5007/5006)
ED560913	Silicon Diode 1S2473VE	D4 (CN-5008A)
ED562386	Germanium Diode 1S188AM	D1to3, 5, 6 (CN-5008A)
EJ249232	Headphone Jack	J1 (CN-5008C)
EL283184	Lamp (Reed Type) 8V 100 mA	IND901, 902, 904
EO283050	Oscillator Coil 09A-1359	T1 (CN-5008A)
ER283105	Dolby Filter KM-10D1.9B	FL1 (CN-5008A)
ER283386	Dolby Filter KM-10D85B	FL2 (CN-5008A)
EM213175	VU Meter 190-1	(JPN) M901, 902
EM265116	VU Meter 190-1-PG	(Others) M901, 902
ES280258	Push SW. SDV1P TV-5	SW901
ES283072	Slide SW. SSC22LP	SW1 (CN-5008A)
ES283083	Slide SW. 140025	SW2 (CN-5008A)
ES283116	Push SW. CVE-42	SW3 (CN-5008A)
ES283151	Leaf SW. BSW-31PL	SW904
ES283173	Leaf SW. BSW-31PLC	SW902
ES592964	Leaf SW. BSW-1FTX	SW903
ES665807	Push SW. SDG-5P	SW901 (CEE)
ET241334	Transistor 2SC1384(Q)	TR10 (CN-5008A)
ET399846	Transistor 2SC945L(Q)	TR5 (CN-5008A)
ET399870	Transistor 2SC711(G)	TR7 (CN-5008A)
ET603257	Transistor 2SC1312S(G)(H)	TR1to3 (CN-5008A)
ET552870	FET 2SK30A(Y)(GR)	TR4 (CN-5008A)
ET639437	Transistor 2SC945L(Q)(P)	TR6 (CN-5008A)
EV283127	Volume 50 kAx2	VR1 (CN-5008A)
HE266466	ERASE HEAD HF-213820	
HP266477	REC/PB HEAD MH-424523	
MB282093	Capstan Belt	
MB282284	Counter Belt CN-1039	
MB283421	AS Belt CN-1059	
MC280260	Counter MP-390-211	
MR282767	Motor Pulley CN-7002	

## 2. ILLUSTRATION OF HEAD BASE BLOCK

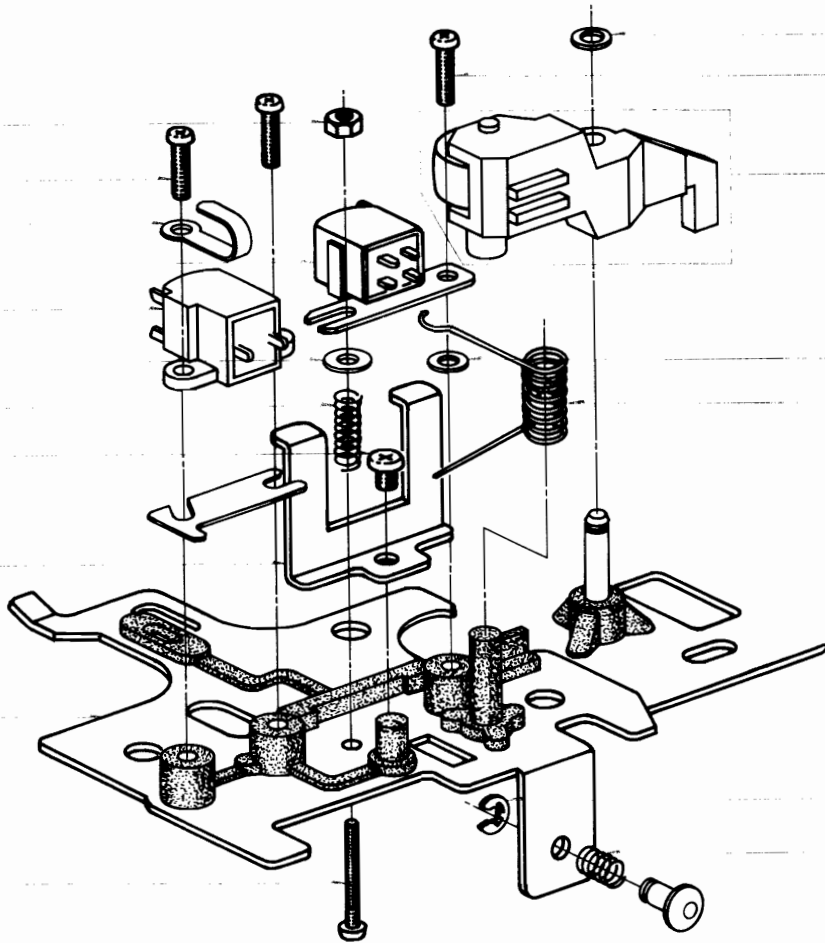

### 2.) HEAD BASE BLOCK

Ref. No.	Parts No.	Description	Schematic Q'ty No.	Ref. No.	Parts No.	Description	Schematic Q'ty No.
2-1x	BH274252	Head Base Block Comp.	1	2-23	MS282374	Pinch Roller Spring	CN-1053 1
2-2	BZ280304	Head Chassis Comp.	CN-0001 1	2-24	ZW282407	Push Washer (B)	CN-1056 1
2-3	TC282025	Safety Base	CN-0003 1	2-25	ZS523664	Tapping Screw #2, 3x10	3
2-4	ZS432674	Screw, pan head 3x3	1			(BR)	
2-5	HE266466	ERASE HEAD HF213820	37-2-8 1	2-26	ZS650013	Tapping Screw #1, 3x25	1
2-6	HZ301161	Head Wiring Hook	CN-0008 1			(BR)	
2-7	ZS300436	Tapping Screw #2, 2.3x8	2				
		(Bind)					
2-8	ZG282036	Adjust. Spring	CN-0004 1				
2-9	HR266477	REC/PB HEAD					
		MH424523	37-2-9 1				
2-10	ZW609311	Nut M2, #1	1				
2-11	ZW300888	Qasher D2.3x6x0.4t	1				
2-12	ZS522180	Tapping Screw #2, 2x8	1				
		(Pan)					
2-13	ZW300883	Washer D2.3x6x0.1t	1				
2-14x	ZW300884	Washer D2.3x6x0.15t	1				
2-15x	ZW300885	Washer D2.3x6x0.2t	1				
2-16x	ZW300886	Washer D2.3x6x0.25t	1				
2-17x	ZW300887	Washer D2.3x6x0.3t	1				
2-18	ZS300435	Screw, pan head 2x12	1				
2-19x	ZG298350	Spring (B)	CN-1068 1				
2-20	ZG282183	Spring	CN-1028 1				
2-21	ZW270088	'E' Ring 1.9M	6-1-9 1				
2-22	BZ274263	Pinch Roller Arm Block					
		Comp.	CN-9708 1				

When ordering parts, please describe Parts Number, Description, and Model Number in detail.

### 3. ILLUSTRATION OF FLYWHEEL/MOTOR BLOCK

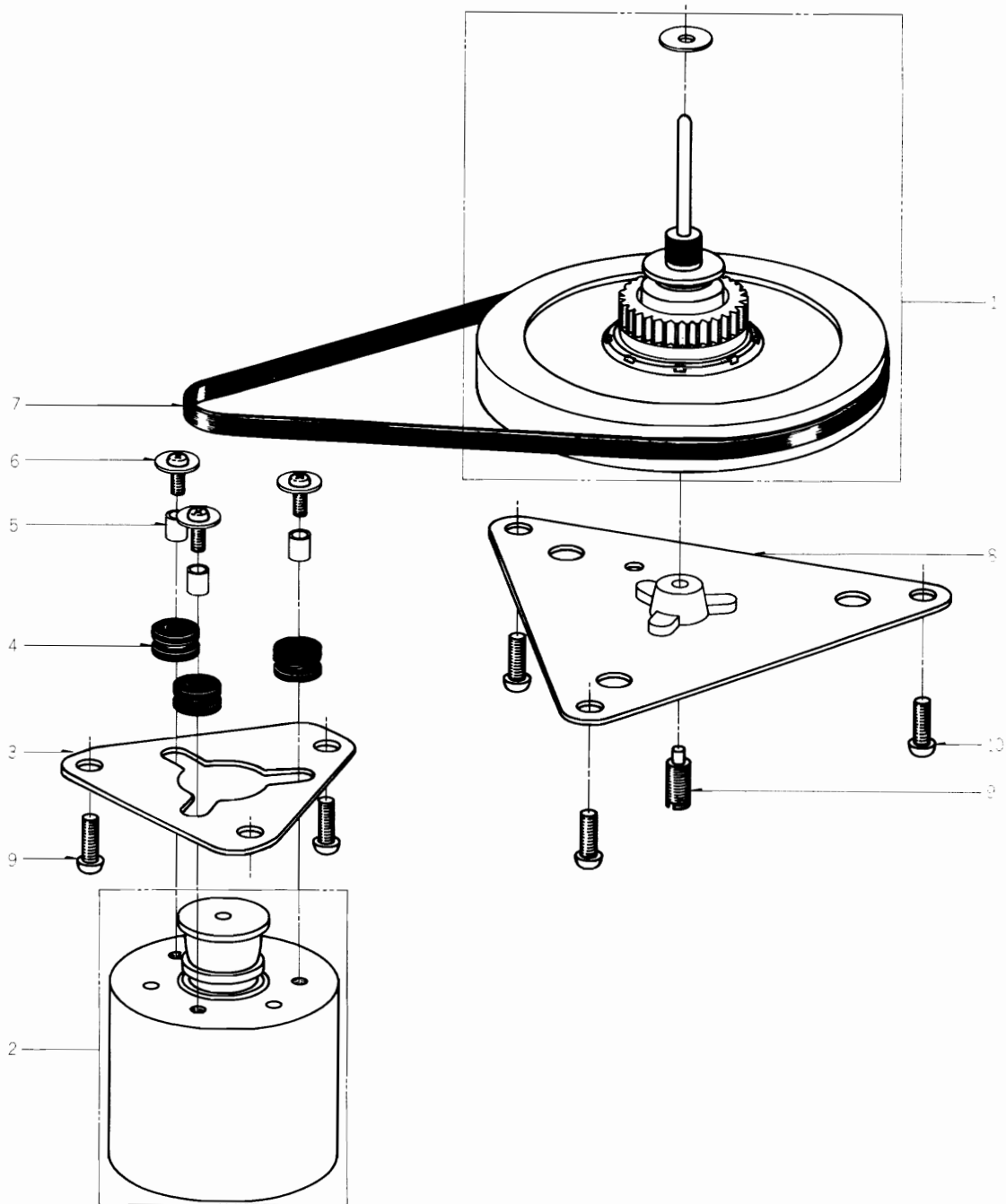

### 3.) FLYWHEEL/MOTOR BLOCK

Ref. No.	Parts No.	Description	Schematic No.	Q'ty
3-1	BF274217	Flywheel Block Comp.		1
3-2	BM302788	Motor Block Comp.		1
3-3	TC282756	Motor Mt. Plate	CN-7001	1
3-4	MB282778	Rubber Bush	CN-7003	3
3-5	ZW283195	Spacer 2.6x4	7-2-6	3
3-6	ZS296482	Screw, pan head 2.6x6 PW		3
3-7	MB282093	Capstan Belt	CN-1017	1
3-8	BZ280337	Flywheel Holderplate Comp.	CN-1018	1
3-9	ZS297628	Adjust Screw	CN-1069	1
3-10	ZS447840	Tapping Screw #2 3x8 (BR)		6

---

#### 4. ILLUSTRATION OF MECHA FRAME BLOCK

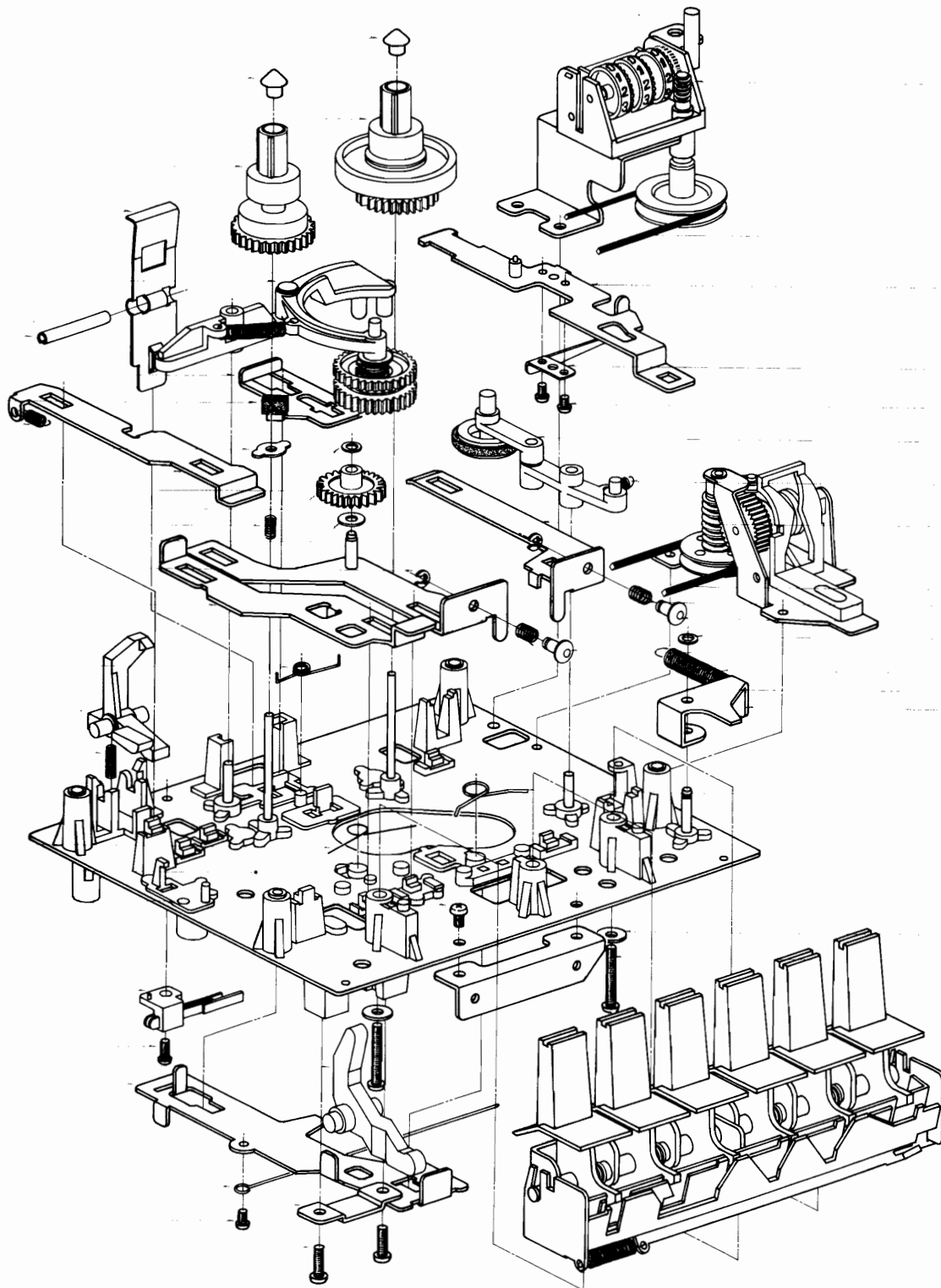

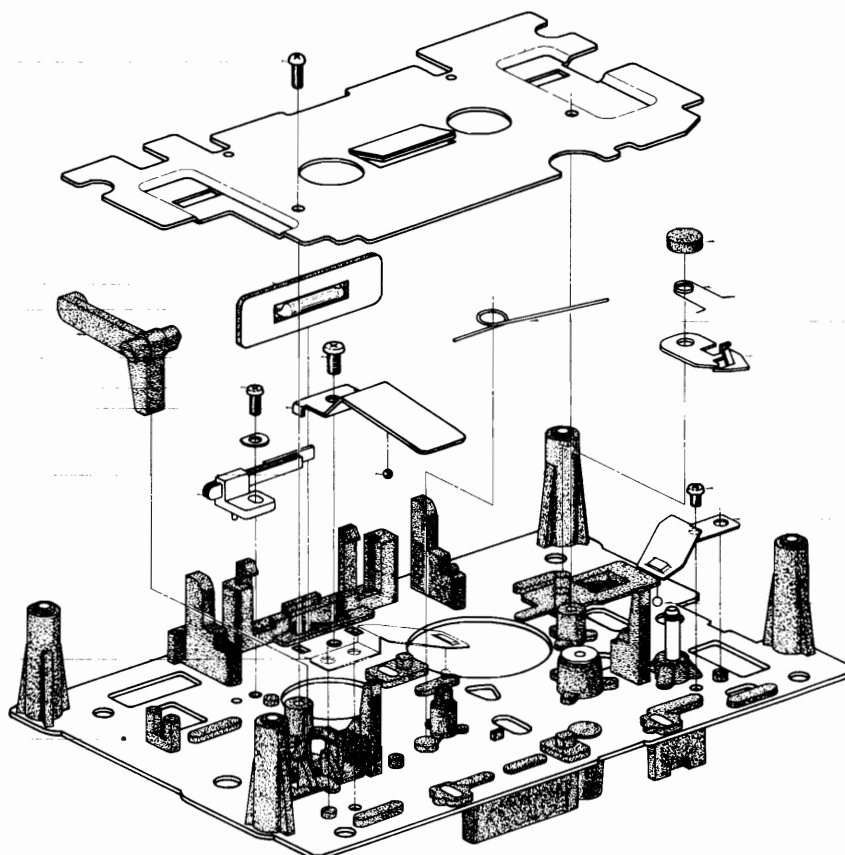

#### 4.) MECHA FRAME BLOCK

Ref. No.	Parts No.	Description	Schematic Q'ty No.	Ref. No.	Parts No.	Description	Schematic Q'ty No.
4-1	BZ280326	Chassis (A) Comp.	CN-1001	4-35	TC282194	F.F Slide	CN-1029
4-2	TC282047	Brake Slide (B)	CN-1012	4-36	BL282508	Take-up Lever Comp.	CN-2022
4-3	TC282238	Reset Spoke	CN-1034	4-37	MB283421	AS Belt	CN-1066
4-4	ZS417251	Screw, binding head 2.3x3	1	4-38	ZG282431	REC Safety Spring	CN-1059
4-5	ML282328	Rec Lever	CN-1043	4-39	ML282240	REC Safety Lever	CN-1035
4-6	MZ282330	Rec Lever Stopper	CN-1044	4-40	ZG282251	Cassette Stopping Spring	CN-1036
4-7	ZS447840	Tapping Screw #2 3x8 (BR)	2	4-41	MH284185	Spring Pin	1
4-8	ES283151	Leaf SW, BSW-31(PL)	25-10-25	4-42	ZG387178	Idler Tension Spring	CS-1106
4-9	ZS537085	Screw, binding head 2x5	1	4-43	TC268468	Pause Slide Part CN	CN-1031
4-10	MC280260	Counter MP-390-211	9-1-53	4-44	TC282227	Scraper	CN-1033
4-11x	ZS417216	Screw, pan head 3x4	5	4-45	ZS374646	Screw, pan head 2x2	1
4-12	BZ282881	Auto Stop Comp.	CN-3014	4-46	ML282273	Auto Stop Lever	CN-1038
4-13x	ZS432843	Screw, pan head 2.6x4	2	4-47	ZG606723	Spring T	KJ-2059
4-14	ZG282115	Brake Spring	CN-1021	4-48	BZ280315	Mecha Chassis (B) Comp.	CN-1004
4-15	TC282262	Brake Slide (A)	CN-1037	4-49	ML282295	Eject Lever	CN-1040
4-16	MB282104	Brake Rubber	CN-1020	4-50	ES283173	Leaf SW. BSW-3/PLC	25-10-26
4-17	ZG282464	Return Spring (B)	CN-1065	4-51	ZS537085	Screw, binding head 2x5	1
4-18	ZW282407	Push Washer (B)	CN-1056	4-52	EA283408	Housing Lamp P.C Board	CN-5008B
4-19	TC282161	RWD Wheel	CN-1026	4-53	EL283184	Lamp (Reed Type) 8V 100 mA	28-2-59
4-20	ZW694798	Washer (Teflon) D3.1x7x0.2t	1	4-54	TC515575	SW. Lock Cam B	CG-2301
4-21	ZW270088	'E' Ring 1.9M	6-1-9	4-55	ZG632553	Button Lock Spring C	CG-2303
4-22	ZG282183	Spring	CN-1028	4-56	TC282396	Cap	CN-1055
4-23	MS282172	Spring Shaft	CN-1027	4-57	MV357208	Steel Ball D2	6
4-24	ZG282418	Back Tension Spring	CN-1057	4-58	ZG282341	Head Return Spring	CN-1048
4-25	ZW282420	Spring Spot Facing Washer	CN-1058	4-59	ZG282352	Head Base Stopping Spring	CN-1049
4-26	BR282497	Supply Reel Table Comp.	CN-2021	4-60	ZS417216	Screw, pan head 3x4	3
4-27	MT282468	Reel Cap	CN-2008	4-61	BK282870	Keyboard Comp.	CN-3011
4-28	BL282510	Middle Lever Comp.	CN-2023	4-62	ZW550642	Washer (SPC) D3.1x7.9x0.5t	3
4-29	BR282475	Take-up Reel Table Comp.	CN-2001	4-63	ZS608253	Screw, pan head 3x20	3
4-30	MB282284	Counter Belt	CN-1039	4-64	ZS265307	Tapping Screw #2, 2.3x6 (Truss)	2
4-31	ZG282126	Return Spring	CN-1022	4-65x	ZW287458	Washer D3.3x6x0.3t	1
4-32	TC282137	Rec Slide	CN-1023	4-66	ZG300881	Head Retaining Spring (A)	CN-1070
4-33	ZG385986	Safety Lever Return Spring	CS-2539	4-67	ZG300882	Head Retaining Spring (B)	CN-1070
4-34	TC282205	Eject Slide	CN-1030	4-68	ZS201407	Screw, pan head 2.3x3	2

When ordering parts, please describe Parts Number, Description, and Model Number in detail.

## 5. P.C BOARDS

### (1) PRE AMP P.C BOARD (CN-5008A) BLOCK

Symbol No.	Parts No.	Description	Schematic No.	Q'ty
(1)-1	BA274004	Pre Amp P.C Board Comp. (CN-5008)		1
(1)-IC1	EI605013	IC NE545B	45-8-117	2
(1)-TR1to3	ET603257	Transistor 2SC1312S(G)(H)	45-1-182	6
(1)-TR4	ET552870	FET 2SK30A(Y)(GR)	45-12-4	2
(1)-TR5	ET399846	Transistor 2SC945L(Q)	45-1-85	2
(1)-TR6	ET639437	Transistor 2SC945L(Q)(P)	45-1-85	2
(1)-TR7	ET399870	Transistor 2SC711(G)	45-1-67	2
(1)-TR8,9	ET639437	Transistor 2SC945L(Q)(P)	45-1-85	4
(1)-TR10	ET241334	Transistor 2SC1384(Q)	45-1-173	1
(1)-TR11	ET603257	Transistor 2SC1312(G)(H)	45-1-182	1
(1)-D1to3	ED562386	Germanium Diode 1S188AM	45-3-24	6
(1)-D5,6	ED562386	Germanium Diode 1S188AM	45-3-24	4
(1)-VR2	EV464220	Semi-fixed/Vol. V8K4-1 50 k $\Omega$	36-10-266	2
(1)-VR4	EV464207	Semi-fixed/Vol. V8K4-1 5 k $\Omega$	36-10-266	2
(1)-VR5	EV520806	Semi-fixed/Vol. V8K4-1 10 k $\Omega$	36-10-266	2
(1)-VR6	EV300270	Semi-fixed/Vol. V8K4-1 300 k $\Omega$	36-10-266	2
(1)-T1	EO283050	OSC Coil 33Y-1007A	23-4-40	1
(1)-L1	EO692741	Ferri Inductor 33Y-740	23-1-254	2
(1)-L2	EP656943	Inductor 22MH(J)	23-1-245	2
(1)-FL1	ER283105	Dolby Filter FB-1802M	53-1-115	2
(1)-FL2	ER283386	Dolby Filter KM-10D85B	53-1-115	2
(1)-SW1	ES283072	Slide SW. SSC22LP	25-3-131	1
(1)-SW2	ES283083	Slide SW. 140025	25-3-132	1
(1)-2	MZ287471	Base Post BCC-5	42-1-101	1
(1)-3	EZ245924	Base Post BCC-4	42-1-101	1
(1)-4	MZ287460	Base Post BCC-3	42-1-101	1
(1)-5	MZ277482	Base Post BCC-2	42-1-101	4
(1)-6	TC297257	OSC Shield Plate (B)	CN-5024	1
(1)-R29	ER280710	Metal Oxide Film/R. 3W 100 ohms (J)	35-15-19	1
(1)-R66	ER538121	Cement/R. 5W 68 ohms (K)(Wire-wound Type)	35-16-3	1
(1)-C3	EC280383	Styrol/C. 470PF(K) 50WV (w/rubber)	24-11-12	2
(1)-C6	EC280361	Styrol/C. 390PF(K) 50WV (w/rubber)	24-11-12	2
(1)-C42	EC265421	Styrol/C. 150PF(K) 50WV (w/rubber)	24-11-12	2
(1)-C45	EC284152	Styrol/C. 1000PF(J) 250WV (w/rubber)	24-11-12	1

### (2) POWER SUPPLY P.C BOARD (CN-5007) BLOCK (CN-5006)

Symbol No.	Parts No.	Description	Schematic No.	Q'ty
(2)-1	BA274061	Power Supply P.C Board Comp. (CN-5007)		1
(2)-2	BA274116	Power Supply P.C Board Comp. (CN-5006)(JPN)		1
(2)-3	BA274105	Power Supply P.C Board Comp. (CN-5006) (AAL)		1
(2)-4	BA274049	Power Supply P.C Board Comp. (CN-5006) (CSA)		1
(2)-5	BA274083	Power Supply P.C Board Comp. (CN-5006) (CEE)		1
(2)-6	BA268492	Power Supply P.C Board Comp. (CN-5006) (BEAB)		1
(2)-TR1	ET649034	Transistor 2SC1449(K)(L)	45-1-214	1
(2)-D1	ED498150	Zener Diode WZ-192	45-6-67	1
(2)-D2	ED249581	Silicon Diode SIQB20 0.6A 200V (Red)	45-2-74	1
(2)-D3	ED284095	Silicon Diode SIQB20 0.6A 100V (Blk)	45-2-74	1
(2)-7	MZ283140	Voltage Charger 12M-60031 (U/T)	40-2-13	1
(2)-8	EZ282532	Heat-sink	CN-5005	1
(2)-9	ZS558101	Screw, pan head 3x6 w/washer		1
(2)-10	ZS379350	Screw, pan head 3x6		2
(2)-11	EJ514822	Fuse Holder, P.C Board S-N5051 (U/T, JPN, AAL, CSA)	40-1-28	4
(2)-12	EJ592503	Fuse Clip, P.C Board H0426 (CEE)	40-1-37	4
(2)-13	EJ592503	Fuse Clip, P.C Board H0426 (BEAB)	40-1-37	6
(2)-C7	EC699298	PE-9P Film/C. 0.1 $\mu$ F(K) 600WV (U/T, CEE)	24-3-8	1

### (3) VU LAMP P.C BOARD (CN-5012) BLOCK

Symbol No.	Parts No.	Description	Schematic No.	Q'ty
(3)-1	BA274050	VU Lamp P.C Board Comp. (CN-5012)		1
(3)-D901	ED249377	LED GL-3ARI	45-15-14	1
(3)-D902	ED283138	LED GL-32PG	45-15-15	1
(3)-IND901,902	EL283184	Lamp (Reed Type) 8V 100 mA	28-2-59	2
(3)-2	TC282554	Lamp Holder	CN-5013	2

## 6. ILLUSTRATION OF AMP ASSEMBLY BLOCK

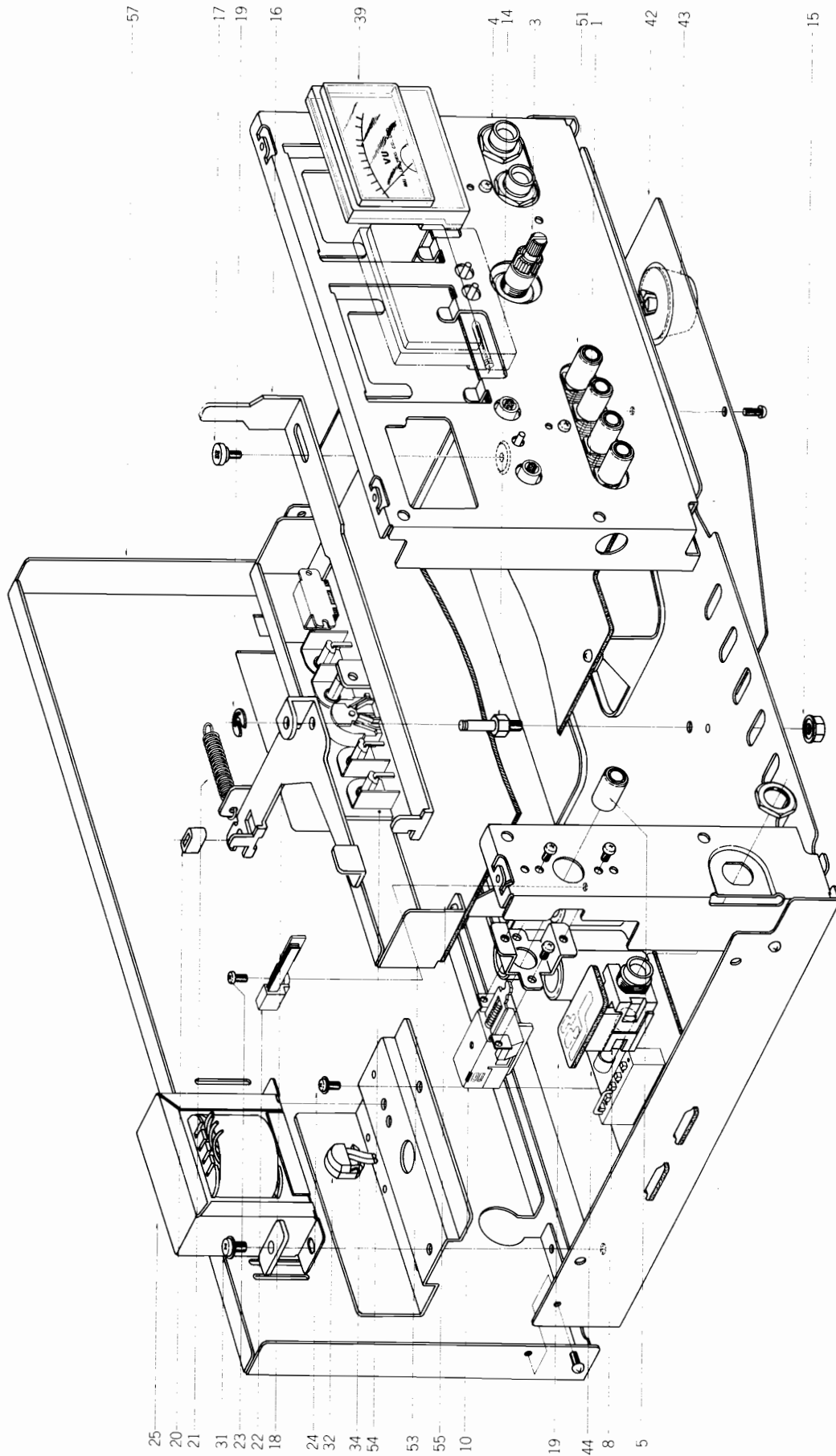

## 6.) AMP ASSEMBLY BLOCK

Ref. No.	Parts No.	Description	Schematic No.	Q'ty	Ref. No.	Parts No.	Description	Schematic No.	Q'ty
<b>VOL. RETAINING BASE BLOCK</b>					<b>PRE AMP BLOCK</b>				
6-1	ES283116	Push SW. CVE-42	25-5-242	1	6-53	TC282813	Jack Plate Mt. Base	CN-5021	1
6-2x	ZS323728	Screw, binding head 3x5		2	6-54	EJ283094	4P Pin Jack 1-01-0107-00	31-5-137	1
6-3	EV283127	Double axial 2 throw			6-55	ZS325495	Tapping Screw #2, 3x6 (BR)		4
		Vol. 50 kAx2	36-3-77	1					
6-4	EJ280293	Mic. Jack LJ255-1-16	31-2-77	2	6-56x	ZW273802	Toothed Lock Washer		2
<b>FRONT CHASSIS (L) BLOCK</b>									
6-5	SK631304	Push Button Knob 1 MY-2	91-5051	1	6-57	SP280247	Rear Panel (B)	CN-6019B1	1
6-6x	SB645232	Selector Button (CEE)	CA-6011	1	6-58	SP282835	Rear Panel (AAL)	CN-6019	1
6-7x	ZS422076	Screw, pan head 3x5		4					
6-8	EJ249232	Headphone Jack MU	31-2-77	1					
6-9	EA283410	Headphone P.C Board	CN-5008C	1					
6-10	ES293703	Push SW. SDVIP TV-5	25-5-254	1					
6-11x	ES665807	Push SW. SDG-5P (CEE)	25-5-182	1					
6-12x	ES280258	Push SW. SDVIP TV-5							
		(AAL)	25-5-243	1					
6-13x	ZS674537	Tapping Screw #2, 3x6 (BR) w/washer		1					
<b>AMP CHASSIS BLOCK</b>									
6-14	MH282587	REC Lever Prop	CN-5020	1					
6-15	ZW413267	Flange Nut M4		1					
6-16	TC282521	REC Slide	CN-5002	1					
6-17	ZS469710	MR Graduated Screw	MR-254	1					
6-18	ML282936	REC Lever	CN-5003	1					
6-19	ZW290283	'U' Ring 2.85M	6-1-1	1					
6-20	MB510164	Cussion Rubber	CG-7306	1					
6-21	ZG323763	REC. Lever Return Spring, MRA	MR-554	1					
6-22	ES301747	Leaf SW. BSW-1F TX-2	25-10-30	1					
6-23	ZS323728	Screw, binding head 3x5		1					
6-24	ZS201767	Screw, pan head 4x6 w/washer		2					
6-25	BT283048	Power Trans. CNT-5	38-4-470	1					
6-26x	BT283037	Power Trans. CNT-4 (JPN)	38-4-469	1					
6-27x	BT301773	Power Trans. CNT-6 (AAL)	38-4-501	1					
6-28x	BT283004	Power Trans. CNT-1 (CSA)	38-4-466	1					
6-29x	BT283015	Power Trans. CNT-2 (CEE)	38-4-467	1					
6-30x	BT283026	Power Trans. CNT-3 (BEAB)	38-4-468	1					
6-31	ZS558101	Screw, pan head 3x6 w/washer		2					
6-32	ZS631945	Strain Relief SR-4N-N	2-7-49	1					
6-33x	EJ692908	Strain Relief SR-5N-4 (BEAB)	2-7-60	1					
6-34	EW540123	AC Cord (CUL) 2.5M	26-3-20	1					
6-35x	EW557640	AC Cord (J) 2.5M	26-3-32	1					
6-36x	EW516475	AC Cord (CSA) 2.5M	26-3-45	1					
6-37x	EW604618	AC Cord (KMA) VM-0064	26-3-34	1					
6-38x	EW232244	AC Cord Basec 2 Core	26-3-46	1					
6-39	EM265116	VU Meter 190-1-PG	46-1-146	2					
6-40x	EM213175	VU Meter 190-1 (JPN)	46-1-142	2					
6-41x	ZS325495	Tapping Screw #2 3x6 (BR)		5					
6-42	SP300625	Lower Cover (B)	CN-6029	1					
6-43	SA300573	Rubber, Foot (8MM)	2-6-17	4					
	SA280282	Rubber, Foot (12MM)	2-6-16	4					
6-44	EF563681	Fuse 1A 250V (U/T, JPN)	39-1-50	1					
6-45x	EF575932	Fuse 0.8A 250V (U/T, JPN)	39-1-50	1					
6-46x	EF304626	Fuse ST-4 1A (AAL, CSA)	39-1-28	1					
6-47x	EF277424	Fuse ST-4 0.8A (AAL, CSA)	39-1-28	1					
6-48x	EF601942	Fuse 630MAT (SEMKO T Type) (CEE, BEAB)	39-1-53	1					
6-49x	EF668474	Fuse 400MAT (SEMKO T Type) (CEE, BEAB)	39-1-53	1					
6-50x	EF601942	Fuse 630MAT (SEMKO T Type) (BEAB)	39-1-53	1					
6-51	SK634410	Push Button Knob J TE	91-5051	4					
6-52x	ZS523664	Tapping Screw 2, 3x10 (BR)		2					

When ordering parts, please describe Parts Number, Description, and Model Number in detail.



## 7. PHOTO OF FINAL ASSEMBLY BLOCK



## 7.) FINAL ASSEMBLY BLOCK

Ref. No.	Parts No.	Description	Schematic Q'ty No.
<b>FRONT PANEL BLOCK</b>			
7-1	BD273870	Front Panel Block Comp.	1
7-2	SE282701	Escutcheon (A)	CN-6015 1
7-3x	TC282611	Stopper Holder	CN-6003 1
7-4x	MZ282633	Stopper	CN-6005 2
7-5x	ZS608275	Screw, pan head 3x5, w/washer	2
7-6x	TC281024	Pin Stand (L) Part CN	CN-6007 1
7-7x	TC281035	Pin Stand (R) Part CN	CN-6007 1
<b>FINAL ASSEMBLY BLOCK</b>			
7-8x	ZS608275	Screw, pan head 3x5, w/washer	6
7-9x	ZW259492	Washer (PBP) D3.1x8x0.3t	2
7-10x	TC282824	Lid Frame	CN-6010 1
7-11x	ZG282690	Set Spring	CN-6009 2
7-12x	ZS201407	Screw, pan head 2.3x3	2
7-13x	MB282778	Rubber Bush	CN-7003 2
7-14x	ZG282644	Lid Frame Spring (L)	CN-6006 1
7-15x	ZG282655	Lid Frame Spring (R)	CN-6006 1
7-16x	ZW290283	'U' Ring 2.85M	6-1-1 2
7-17	BD300297	Lid Case Comp. CN	1
7-18x	ZS325495	Tapping Screw #2 3x6 (BR)	12
7-19x	ZS523664	Tapping Screw #2 3x10 (BR)	4
7-20x	ZS327835	Screw, countersunk head 3x5	1
7-21x	ZW603797	Adjust. Washer (U) D4x13x0.5t	2
7-22x	ZW413190	Adjust. Washer (U) D4x13x0.8t	2
7-23x	ZW330423	Adjust. Washer (U) D4x13x0.25t	2
7-24	SK639977	Double Knob (Lower)	TY-6009 1
7-25	SK639988	Double Knob (Upper)	TY-6008 1
7-26	TC282925	Upper Cover	CN-6017 1
7-27x	TC301674	Upper Cover (B) (AAL)	CN-6017 1
7-28	ZS290553	Screw, binding head 4x8 (W=10)	4

## 8. LIST OF INTERCHANGEABLE SEMICONDUCTORS

As far as service is concerned, in case the original parts cannot be obtained, the interchangeable parts listed below can be substituted.

Original Parts			Interchangeable Parts	
Description	Parts No.	Utilizing P.C Board	Description	Parts No.
2SC711 (G)	ET399870	CN-5008A	2SC536 (G) (H) 2SC1647 (S) (E) (U)	ET403391 ET601312
2SC945L (Q)	ET399846	CN-5008A	2SC711 (E) (F) 2SC1647 (R) (S) (E)	ET453486 ET623733
2SC945L (Q) (P)	ET639437	CN-5008A	2SC711 (E) (F) 2SC1647 (R) (S) (E)	ET453486 ET623733
2SC1312S (G) (H)	ET603257	CN-5008A	2SC458LG (C) 2SC693U (F)	ET234854 ET315472
2SC1384 (Q)	ET241334	CN-5008A	2SC1211 (C) (D) 2SD400 (K)	ET430907 ET631877
2SC1449 (K) (L)	ET649034	CN-5007 (U/T) CN-5006 (Other)	2SD313 (E) (F)	ET452531
2SK30A (Y) (GR)	ET552870	CN-5008A		
NE545B	EI605013	CN-5008A		
SIQB20 0.6A 200V (RED)	ED249581	CN-5007 (U/T) CN-5006 (Other)	SIQB10 0.6A 100V (BLK)	ED284095
WZ-192	ED498150	CN-5007 (U/T) CN-5006 (Other)		
GL-3AR1	ED249377	CN-5012		
GC-3PG1	ED283138	CN-5012		
1S188AM	ED562386	CN-5008A	1N34A 1N60	ED417442 ED428264

# INDEX

Parts No.	Ref. No. & Symbol No.	Parts No.	Ref. No. & Symbol No.	Parts No.	Ref. No. & Symbol No.	Parts No.	Ref. No. & Symbol No.	Parts No.	Ref. No. & Symbol No.
BA268492	(2)-6	ET399846	(1)-TR5	TC301674	7-27x	ZW330423	7-23x		
BA274004	(1)-1	ET399870	(1)-TR7	TC515575	4-54	ZW413190	7-22x		
BA274050	(3)-1	ET552870	(1)-TR4	ZG282036	2-8	ZW413267	6-15		
BA274061	(2)-1	ET603257	(1)-TR1to3	ZG282115	4-14	ZW550642	4-62		
BA274083	(2)-5	ET603257	(1)-TR11	ZG282126	4-31	ZW603797	7-21x		
BA274094	(2)-4	ET639437	(1)-TR6	ZG282183	2-20	ZW609311	2-10		
BA274105	(2)-3	ET639437	(1)-TR8, 9	ZG282183	4-22	ZW694798	4-20		
BA274116	(2)-2	ET649034	(2)-TR1	ZG282251	4-40				
BD273870	7-1	EV283127	6-3	ZG282341	4-58				
BD300297	7-17	EV300270	(1)-VR6	ZG282352	4-59				
BF274217	3-1	EV464207	(1)-VR4	ZG282418	4-24				
BH274252	2-1x	EV464220	(1)-VR2	ZG282431	4-38				
BK282870	4-61	EV520806	(1)-VR5	ZG282464	4-17				
BL282508	4-36	EW232244	6-38x	ZG282644	7-14x				
BL282510	4-28	EW516475	6-36x	ZG282655	7-15x				
BM302788	3-2	EW540123	6-34	ZG282690	7-11x				
BR282475	4-29	EW557640	6-35x	ZG298350	2-19x				
BR282497	4-26	EW604618	6-37x	ZG300881	4-66				
BT283004	6-28x	EZ245924	(1)-3	ZG300882	4-67				
BT283015	6-29x	EZ282532	(2)-8	ZG323763	6-21				
BT283026	6-30x	EZ631945	6-32	ZG385986	4-33				
BT283037	6-26x	HE266466	2-5	ZG387178	4-42				
BT283048	6-25	HR266477	2-9	ZG606723	4-47				
BT301773	6-27x	HZ301161	2-6	ZG632553	4-55				
BZ274263	2-22	MB282093	3-7	ZS201407	4-68				
BZ280304	2-2	MB282104	4-16	ZS201407	7-12x				
BZ280315	4-48	MB282284	4-30	ZS201767	6-24				
BZ280326	4-1	MB282778	3-4	ZS265307	4-64				
BZ280337	3-8	MB282778	7-13x	ZS290553	7-28				
BZ282881	4-12	MB283421	4-37	ZS296482	3-6				
EA283408	4-52	MB510164	6-20	ZS297628	3-9				
EA283410	6-9	MC280260	4-10	ZS300435	2-18				
EC265421	(1)-C42	MH282587	6-14	ZS300436	2-7				
EC280361	(1)-C6	MH284185	4-41	ZS323728	6-2x				
EC280383	(1)-C3	ML282240	4-39	ZS323728	6-23				
EC284152	(1)-C45	ML282273	4-46	ZS325495	6-41x				
EC699298	(2)-C7	ML282295	4-49	ZS325495	6-55				
ED249377	(3)-D901	ML282328	4-5	ZS325495	7-18x				
ED249581	(2)-D2	ML282936	6-18	ZS327835	7-20x				
ED283138	(3)-D902	MS282172	4-23	ZS374646	4-45				
ED284095	(2)-D3	MS282374	2-23	ZS379350	(2)-10				
ED498150	(2)-D1	MT282486	4-27	ZS417216	4-11x				
ED562386	(1)-D1to3	MV357208	4-57	ZS417216	4-60				
ED562386	(1)-D5, 6	MZ282330	4-6	ZS417251	4-4				
EF277424	6-47x	MZ282633	7-4x	ZS422076	6-7x				
EF304626	6-46x	MZ283140	(2)-7	ZS432674	2-4				
EF563681	6-44	MZ287460	(1)-4	ZS432843	4-13x				
EF575932	6-45x	MZ287471	(1)-2	ZS447840	3-10				
EF601942	6-48x	MZ287482	(1)-5	ZS447840	4-7				
EF601942	6-50x	SA300573	6-43	ZS469710	6-17				
EF668474	6-49x	SB645232	6-6x	ZS522180	2-12				
EI605013	(1)-IC1	SE282701	7-2	ZS523664	2-25				
EJ249232	6-8	SK631304	6-5	ZS523664	6-52x				
EJ280293	6-4	SK634410	6-51	ZS523664	7-19x				
EJ283094	6-54	SK639977	7-24	ZS537085	4-9				
EJ514822	(2)-11	SK639988	7-25	ZS537085	4-51				
EJ592503	(2)-12	SP280247	6-57	ZS558101	(2)-9				
EJ592503	(2)-13	SP282835	6-58x	ZS558101	6-31				
EJ692908	6-33x	SP300625	6-42	ZS608253	4-63				
EL283184	4-53	TC268468	4-43	ZS608275	7-5x				
EL283184	(3)-IND901, 902	TC281024	7-6x	ZS608275	7-8x				
EM213175	6-40x	TC281035	7-7x	ZS650013	2-26				
EM265116	6-39	TC282025	2-3	ZS674537	6-13x				
EO283050	(1)-T1	TC282047	4-2	ZW259492	7-9x				
EO692741	(1)-L1	TC282137	4-32	ZW270088	2-21				
EP656943	(1)-L2	TC282161	4-19	ZW270088	4-21				
ER280710	(1)-R29	TC282194	4-35	ZW273802	6-56x				
ER283105	(1)-FL1	TC282205	4-34	ZW282407	2-24				
ER283386	(1)-FL2	TC282227	4-44	ZW282407	4-18				
ER538121	(1)-R66	TC282238	4-3	ZW282420	4-25				
ES280258	6-12x	TC282262	4-15	ZW283195	3-5				
ES283072	(1)-SW1	TC282396	4-56	ZW287458	4-65x				
ES283083	(1)-SW2	TC282521	6-16	ZW290283	6-19				
ES283116	6-1	TC282554	(3)-2	ZW290283	7-16x				
ES283151	4-8	TC282611	7-3x	ZW300883	2-13				
ES283173	4-50	TC282756	3-3	ZW300884	2-14x				
ES293703	6-10	TC282813	6-53	ZW300885	2-15x				
ES301747	6-22	TC282824	7-10x	ZW300886	2-16x				
ES665807	6-11x	TC282925	7-26	ZW300887	2-17x				
ET241334	(1)-TR10	TC297257	(1)-6	ZW300888	2-11				

---

SECTION 3

**SCHEMATIC DIAGRAM**

CS-702D SCHEMATIC DIAGRAM 1541206A

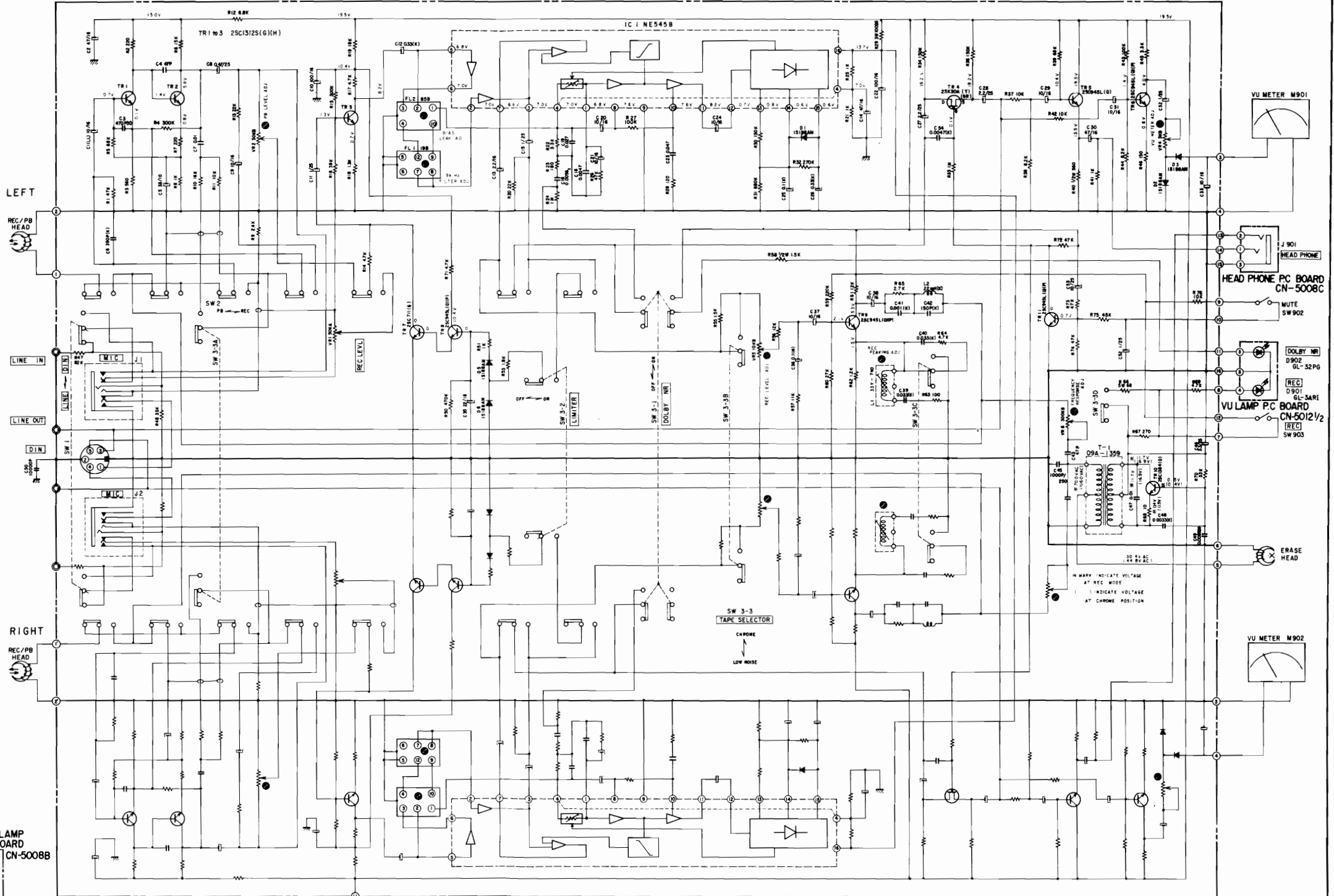
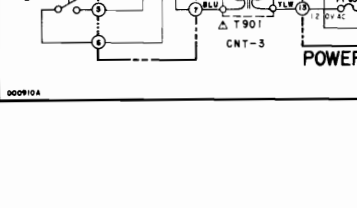
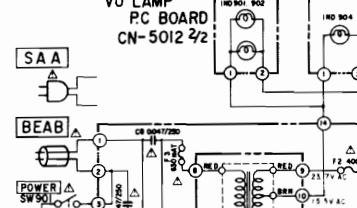
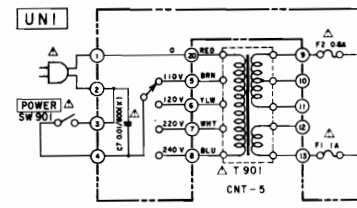
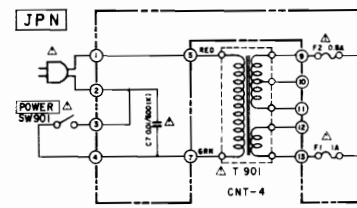
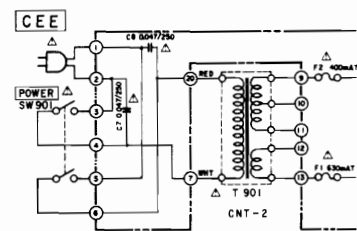
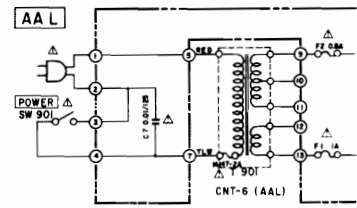
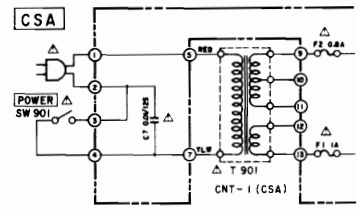

LEFT  
REC/PB HEAD

RIGHT  
REC/PB HEAD

LINE IN  
LINE OUT  
DIN

REC LEVEL  
REC LEVEL

REC LEVEL  
REC LEVEL

REC LEVEL  
REC LEVEL

REC LEVEL  
REC LEVEL

REC LEVEL  
REC LEVEL

REC LEVEL  
REC LEVEL

PRE AMP PC BOARD CN-5008A

HOUSING LAMP PC BOARD CN-5008B

VU LAMP PC BOARD CN-5012 2/2

POWER SUPPLY PC BOARD CN-5007 (UNI ONLY)  
CN-5006 (OTHERS)

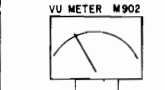
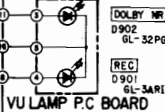
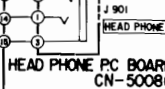
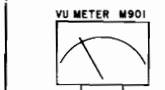

- NOTE
- UNLESS OTHERWISE SPECIFIED  
ALL RESISTORS IN OHMS 1/4W (J)  
ALL CAPACITORS IN  $\mu$ F 50 WV (J)  
P =  $\mu$ F
  - LL INDICATES LOW LEAKAGE CAPACITORS
  - TEMPERATURE FUSE IS INCLUDED IN THE  
POWER TRANSFORMER. FUSE CANNOT BE  
CHANGED SEPARATELY
  - POWER TRANSFORMER IS DIFFERENT ACCORDING  
TO AREA

WARNING:  $\Delta$  INDICATES SAFETY CRITICAL COMPONENTS FOR CONTINUED SAFETY. REPLACE SAFETY CRITICAL COMPONENTS ONLY WITH MANUFACTURER'S RECOMMENDED PARTS.

AVERTISSEMENT:  $\Delta$  IL INDIQUE LES COMPOSANTS CRITIQUES DE SURETE POUR MAINTENIR LE DEGRE DE SECURITE DE L'APPAREIL. NE REMPLACER LES COMPOSANTS DONT LE FONCTIONNEMENT EST CRITIQUES POUR LA SECURITE QUE PAR DES PIECES RECOMMANDEES PAR LE FABRICANT.

CS-702D  
SCHEMATIC DIAGRAM  
No. 1541206A