

INSTRUMENT CATHODE-RAY TUBE

14 cm-diagonal rectangular flat-faced direct-view storage tube with variable persistence and internal graticule, intended for oscilloscope applications.

QUICK REFERENCE DATA

Final accelerator voltage	$V_{g10}(\ell)$	8,5	kV
Display area (10 x 8 divisions of 9 mm)		90 x 72	mm^2
Deflection coefficient, horizontal vertical	M_x	9,5	V/div
	M_y	4,1	V/div
Writing speed		1	cm/ μ s

SCREEN

Metal backed phosphor

	Colour	Persistence (non-store mode)	Persistence (store mode)
L14-110GH/55	green	medium-short	variable

Useful screen dimensions min. 90 x 72 mm

Useful scan, horizontal min. 90 mm
 vertical min. 72 mm

Spot eccentricity in horizontal
 and vertical directions max. 6 mm

The scanned raster can be shifted and aligned with the internal graticule by means of correction coils fitted around the tube by the manufacturer.

HEATING

Writing section

Indirect by a.c. or d.c.; parallel supply

Heater voltage V_f 6,3 V

Heater current I_f 300 mA

Viewing section

Indirect by d.c.; parallel supply

Heater voltage $V_{f'}$ 6,3 V

Heater current $I_{f'}$ 300 mA

Heater voltage $V_{f''}$ 6,3 V

Heater current $I_{f''}$ 300 mA

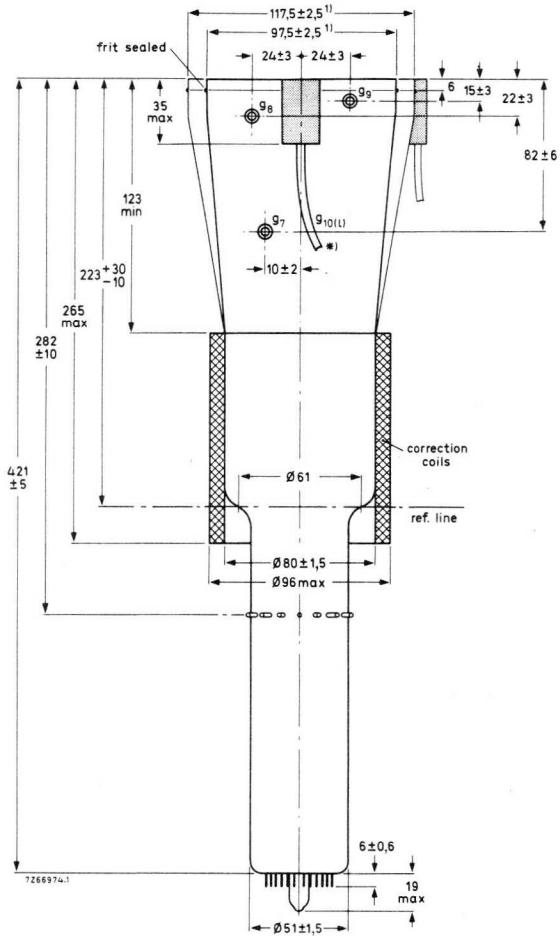

* min. length of cable: 420 mm

¹⁾ The bulge at the frit seal may increase the indicated max. values by not more than 3 mm.

MECHANICAL DATA

Dimensions in mm

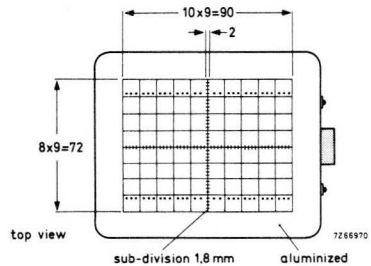
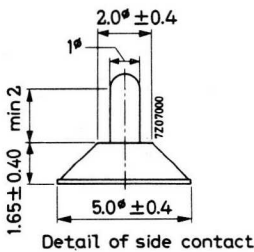
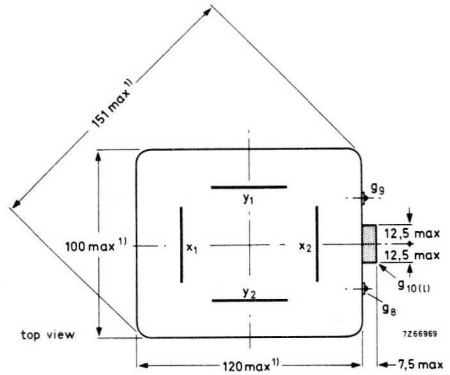
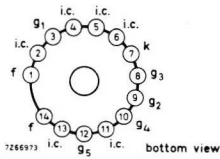
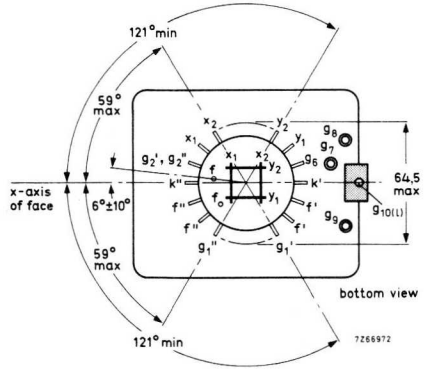
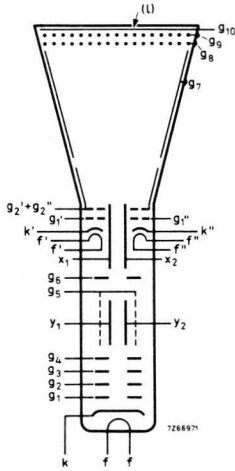

Colour of graticule: brown-black
 Line width 0,15 mm
 Dot diameter 0,3 mm

MECHANICAL DATA (continued)Mounting position: any

The tube should not be supported by the base alone and under no circumstances should the socket be allowed to support the tube.

The tags near the screen should not be subjected to mechanical stress.

Dimensions and connections

See also outline drawing

Overall length (socket included)	max.	445	mm
Face dimensions	max.	100 x 120	mm
<u>Net mass</u>	approx.	1,1	kg
<u>Base</u>		14 pin, all glass	
<u>Accessories</u>			
Socket (supplied with tube)	type	55566	
Side contact connector (14 required)	type	55561	

FOCUSING

electrostatic

DEFLECTION

double electrostatic

x-plates

symmetrical

y-plates

symmetrical

Angle between x and y traces

90 °

Angle between x-trace and x-axis of
the internal graticule

0 °

See also "Correction coils"

LINE WIDTH

Measured with the shrinking raster method in the centre of the screen under typical operating conditions, adjusted for optimum spot size at a beam current $I_b = 10 \mu A$ (measured against x-plates)

Line width at the centre of the screen	l.w.	0,35	mm
--	------	------	----

CAPACITANCES

x_1 to all other elements except x_2	$C_{x_1(x_2)}$	6	pF
x_2 to all other elements except x_1	$C_{x_2(x_1)}$	6	pF
y_1 to all other elements except y_2	$C_{y_1(y_2)}$	3	pF
y_2 to all other elements except y_1	$C_{y_2(y_1)}$	3	pF
x_1 to x_2	$C_{x_1x_2}$	2, 5	pF
y_1 to y_2	$C_{y_1y_2}$	2	pF
g_1 to all other elements	C_{g_1}	6	pF
g_1' to all other elements	$C_{g_1'}$	5, 5	pF
g_1'' to all other elements	$C_{g_1''}$	5, 5	pF
k to all other elements	C_k	5	pF
k' to all other elements	$C_{k'}$	5	pF
k'' to all other elements	$C_{k''}$	5	pF
g_7 to all other elements	C_{g_7}	30	pF
g_9 to all other elements	C_{g_9}	25	pF

TYPICAL OPERATION

Conditions

A. Writing section (voltages with respect to writing gun cathode k)

Final accelerator voltage	$V_{g10(l)}$	8500	V ¹⁾
Geometry control electrode voltage	V_{g6}	1500 ± 100	V
Deflection plate shield voltage	V_{g5}	1500	V ⁸⁾
Astigmatism control electrode voltage	V_{g4}	1500 ± 50	V
Focusing electrode voltage	V_{g3}	400 to 600	V
First accelerator voltage	V_{g2}	1500	V
Control grid voltage for visual extinction of focused spot	V_{g1}	-40 to -80	V

B. Viewing section (voltages with respect to viewing gun cathodes k' and k'')

Final accelerator voltage	$V_{g10(l)}$	7050	V ¹⁾
Backing electrode voltage, storage operation	V_{g9}	0 to 5	V
non-storage operation	V_{g9}	-35	V
Collector voltage	V_{g8}	150	V
Collimator voltage	V_{g7}	30 to 120	V ⁴⁾
First accelerator voltage	$V_{g2'}, g2''$	50	V ⁵⁾
Control grid voltage for cut-off	$V_{g1'}, V_{g1}''$	-30 to -70	V
Cathode current (each viewing gun)	$I_{k'}, I_{k}''$	0, 4	mA

Performance

Grid drive for 10 μ A beam current		≈ 25	V
Deflection coefficient, horizontal	M_x		9, 5 V/div
		max.	10, 5 V/div
vertical	M_y		4, 1 V/div
		max.	4, 4 V/div
Geometry distortion		see note 2	
Deviation of linearity of deflection		max.	2 % ³⁾
Useful scan, horizontal		min.	90 mm
		min.	72 mm
Writing speed in store mode		greater than 100	div/ms ⁶⁾
Storage time		greater than 1, 5	min ⁷⁾

LIMITING VALUES (Absolute max. rating system)**A. Writing section** (voltages with respect to writing gun cathode k)

Final accelerator voltage	$V_{g_{10}(\ell)}$	max. 9500 min. 7000	V V
Geometry control electrode voltage	V_{g_6}	max. 2100	V
Deflection plate shield voltage	V_{g_5}	max. 2000	V
Astigmatism control electrode voltage	V_{g_4}	max. 2100 min. 1200	V V
Focusing electrode voltage	V_{g_3}	max. 1000	V
First accelerator voltage	V_{g_2}	max. 2000 min. 1250	V V
Control grid voltage, positive	V_{g_1}	max. 0	V
negative	$-V_{g_1}$	max. 200	V
Cathode to heater voltage, positive	V_{kf}	max. 125	V
negative	$-V_{kf}$	max. 125	V
Voltage between astigmatism control electrode and any deflection plate	$V_{g_4/x}$ $V_{g_4/y}$	max. 500 max. 500	V V
Grid drive, average		max. 30	V

B. Viewing section (voltages with respect to viewing gun cathodes k' and k'' unless otherwise specified)

Final accelerator voltage	$V_{g_{10}(\ell)}$	max. 8000 min. 5500	V V
Backing electrode voltage, storage operation	V_{g_9}	max. 5 min. 0	V V
non-storage operation	$-V_{g_9}$	max. 50 min. 25	V V
Collector voltage	V_{g_8}	max. 180 min. 120	V V
Collimator voltage	V_{g_7}	max. 200 min. 0	V V
First accelerator voltage	$V_{g_2', g_2''}$	max. 60 min. 40	V V
Cathode to heater voltage, positive	$V_{k'f'}, V_{k''f''}$	max. 125	V
negative	$-V_{k'f'}, -V_{k''f''}$	max. 125	V
Control grid voltage, positive	$V_{g_1'}, V_{g_1''}$	max. 0	V
negative	$-V_{g_1'}, -V_{g_1''}$	max. 200	V

Notes

1. These values are valid at cut-off of both flood guns and the writing gun. The H.T. unit must be capable of supplying 0,5 mA. To protect the tube against excessive surge current during erasure, an adequately dimensioned RC-network must be connected in series with the screen terminal lead.

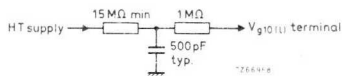

2. A graticule consisting of concentric rectangles of 88 mm x 70 mm and 86 mm x 68,5 mm is aligned with the electrical x-axis of the tube. With optimum corrections applied, a raster will fall between these rectangles.
3. The sensitivity at a deflection less than 75% of the useful scan will not differ from the sensitivity at a deflection of 25% of the useful scan by more than the indicated value.
4. The collimator electrode voltage should be adjusted for optimum uniformity of background illumination.
5. The voltage $V_{g2', g2''}$ should be equal to the mean x-plate potential.
6. The writing speed is defined as the maximum speed at which a written trace is just visible, starting from a background which is just black. The indicated value is guaranteed for the central 80% of the minimum screen area. In addition, in any corner not more than 4 square divisions fall outside the guaranteed area. The writing speed can be increased to approx. 1 cm/μs if some background is tolerated.
7. The storage time is defined as the time required for the brightness of the unwritten background to rise from just zero brightness (viewing-beam cut-off) to 10% of saturated brightness. At reduced intensity (by pulsing the flood beams) the storage time can be increased.
8. This voltage should be equal to the mean y-plate potential. The means x and y-plate potentials should be equal for optimum spot quality.

CORRECTION COILS

General

The L14-110GH/55 is provided with a coil unit (see Fig. 1) consisting of:

1. A pair of coils L3 and L4 which enable the angle between the x and y-traces at the centre of the screen to be made exactly 90° (orthogonality correction).
2. A pair of coils L1 and L2 for image rotation which enable the alignment of the x-trace with the x-lines of the graticule.

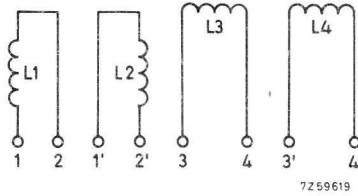

Fig. 1

Orthogonality (coils L₃ and L₄)

The current required under typical operating conditions without a mu-metal shield being used is max. 20 mA for complete correction of orthogonality. It will be 30% to 50% lower with shield, depending on the shield diameter. The resistance of the coil is approx. 225 Ω .

Image rotation (coils L₁ and L₂)

The image rotation coils are wound concentrically around the tube neck. Under typical operating conditions 22 A-turns are required for maximum rotation of 5°. Both coils have 850 turns. This means that a current of max. 12,5 mA per coil is required which can be obtained by using a 12 V supply when the coils are connected in series or a 6 V supply when they are in parallel.

Connecting the coils

The coils have been connected to 8 soldering tags according to Fig. 2.

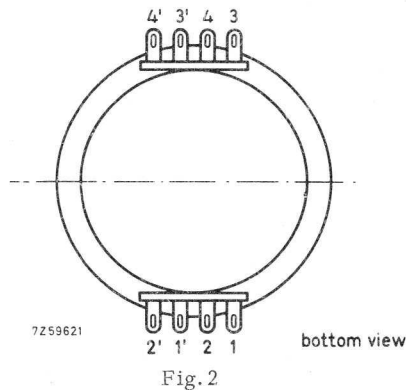

Fig. 2

With L₃ and L₄ connected in series according to Fig. 3 a current in the direction indicated will produce a clockwise rotation of the vertical trace and anti-clockwise rotation of the horizontal trace.

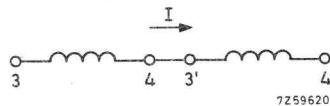

Fig. 3

OPERATING NOTES**Modes of operation**1 Store mode

a. Dynamic erasure (variable persistence)

Dynamic erasure can be achieved by applying erasing pulses of positive polarity to the backing electrode.

The pulse amplitude required is approximately 9 V (< 15 V) and the persistence of a stored display can be controlled by varying the duty factor of these pulses.

b. Static erasure

If no dynamic erasing pulses are applied, the storage time is limited by the potential shift of the storage layer due to landing of positive ions.

In order to erase a stored display, the backing electrode should first be connected to the collector electrode voltage and then returned to its original potential for about 100 ms; after that, an erasing pulse of positive polarity and a duration of not less than 300 ms should be applied. For the adjustment of the amplitude of this pulse see "Procedure of adjustment".

2 Non-store mode

For non-store operation, it is sufficient to make the backing electrode about 35 V negative with respect to the viewing gun cathodes. The viewing guns should not be switched off in this mode of operation since slight variations in raster geometry and deflection sensitivity might otherwise be caused. Care should be taken, especially when switching from store mode to non-store mode, that excessive writing beam current is avoided, as otherwise the storage layer may be damaged.

Procedure of adjustment

a. Adjust the cathode current of each viewing gun to 0,4 mA by means of its control grid voltage.

b. Adjustment of the erasing pulse amplitude (static erasure)

The pulse amplitude should be just sufficient to suppress any background illumination at the centre of the display area (this adjustment should be done under low ambient light conditions).

Data on storage time and maximum writing speed are based on erasure to "just black". A larger pulse amplitude (erasure to "blacker than black") yields a longer storage time at the expense of maximum writing speed. On the other hand, writing speed can be increased if some background illumination is tolerated.

To erase to "just black" the amplitude of this pulse is approximately 9 V.

c. Adjustment of the collimator voltage

With dynamic erasing pulses applied and a persistence control setting that yields a convenient background illumination intensity, the collimator voltage is adjusted for optimum background uniformity. This voltage will be approximately 80 V with respect to the viewing gun cathode potential. If this voltage is too high or too low, there is a decrease of intensity at the four corners or at the centres of the vertical edges of the display area respectively.

For a good erasure of the display, the collimator voltage should be as low as possible.