

For Service Manuals Contact
MAURITRON TECHNICAL SERVICES
8 Cherry Tree Rd, Chinnor
Oxon OX9 4QY
Tel:- 01844-351694 Fax:- 01844-352554
Email:- enquiries@mauritron.co.uk



®

DANGER



It is not possible to screen all high voltages, so care should be taken not to touch high voltage tags. Also where possible the instrument should be unplugged AND switched off during servicing. A BLEEDER PATH FOR THE EHT IS NOT PROVIDED, so after switching off and before touching any internal parts, the EHT should be discharged by temporarily shorting the appropriate points to chassis, (for instance the CRT cathode pin and PDA connector where applicable).



FOR SERVICING AND SPARES ENQUIRIES
SEE THE INFORMATION AT START OF SECTION 5.

TELEQUIPMENT is a registered trade mark of TEKTRONIX U.K. LTD.

TEKTRONIX U.K. LTD
313 Chase Road
Southgate,
London N14 6JJ
ENGLAND.

Telephone
01-882 6100
Telex: 262004
Cables:
TELEQUIPT LONDON N14

TEKTRONIX INC.,
P.O. Box 500
Beaverton,
Oregon (97005)
U.S.A.

Telephone:
(503) 644-0161
Telex: 36 0485
Cables:
TEKTRONIX

OSCILLOSCOPE TYPE D61A

INSTRUCTION MANUAL

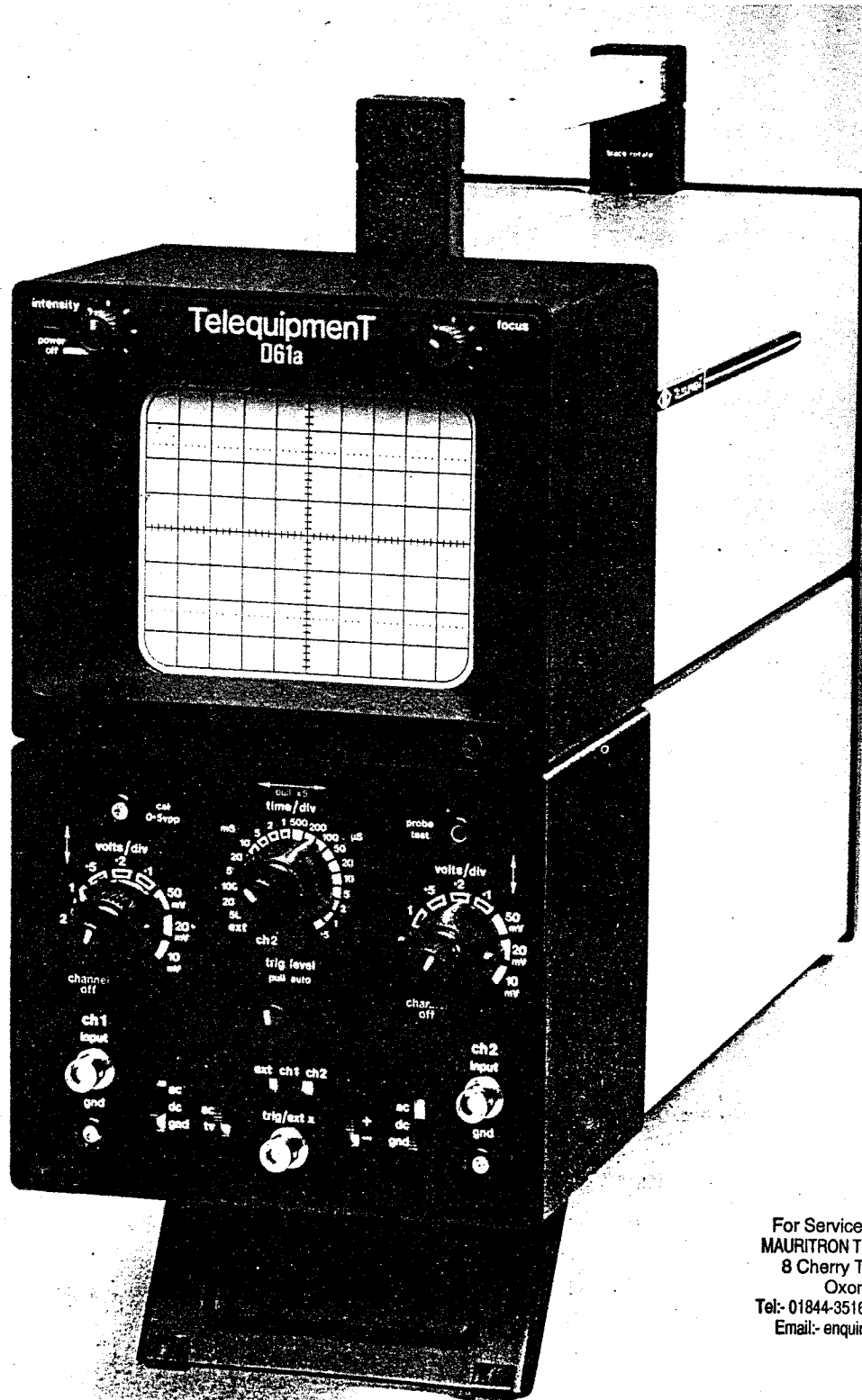

For Service Manuals Contact
MAURITRON TECHNICAL SERVICES
8 Cherry Tree Rd, Chinnor
Oxon OX9 4QY
Tel: 01844-351694 Fax: 01844-352554
Email: enquiries@mauritron.co.uk

INTRODUCTION

The D61A is a 10 MHz solid state dual trace oscilloscope using FET input circuitry for minimum drift and fast stabilization time. A CRT with 8 cm x 10 cm face provides a bright and clear display. The dual trace vertical amplifiers provide the facility for each channel to be displayed separately, alternately or chopped between channels. Channel 2 can be switched to become the horizontal amplifier to provide an X - Y display.

The design of this instrument is subject to continuous development and improvement, consequently this instrument may incorporate minor changes in detail from the information contained herein. This would, in the main, affect the Component List and Circuit Diagrams.

NOTICE TO OWNER

To obviate the risk of damage during transit and to facilitate packaging the owner is requested NOT to send the following items unless they are suspect, should this instrument be returned to TEKTRONIX for servicing.

Manual

Probes

Plug Assemblies

TELEQUIPMENT TYPE D61A OPERATING INSTRUCTIONS

To obtain a trace quickly and easily we suggest you try the following procedure.

1. Put all vertical slide switches up (↑).
2. Put the horizontal slide switch to CH1.
3. Pull the TRIG LEVEL control out.
4. Turn the ↓ (Vertical) and the ↔ (Horizontal) controls so that the Orange marks are vertical. Ensure that the horizontal position control (also X5 switch) is in.
5. Turn the INTENSITY control fully clockwise and allow the instrument to warm up.



D61A – Bruksanvisning

För å hjelpe Dem med førstegangsbruk av dette oscilloskop, anbefaler vi følgende fremgangsmåte:

1. Still alle glidevendere (slide switches) i øverste stilling.
2. Still den horisontale glidevender i stilling CH1.
3. Trekk Trig level-kontrollen ut.
4. Skru ↓ (vertikal) og ↔ (horisontal)-kontrollene, slik at orangemerker blir vertikale. Forsikre Dem om at den horisontale posisjonskontrollen er trykket inn, samt at også X5 er inne.
5. Skru Intensity-kontrollen helt til høyre og gi instrumentet tid til å varmes opp.
6. Still strålen slik at den kommer midt på skjermen ved hjelp av vertikal og horisontal-kontrollene.



BEDIENINGSVOORSCHRIFT TELEQUIPMENT D61A

De onderstaande procedure wordt geadviseerd bij het in gebruik nemen van deze oscilloscoop.

1. Plaats alle verticale schuifschakelaars in de bovenste stand.
2. Plaats de horizontale schuifschakelaar in de stand ch2.
3. Trek de triggerniveauschakelaar ("trig level") uit.
4. Draai de verticale (↓) en horizontale (↔) positieregelingen (buitenste knop van Volts/Div. en Time/Div. knoppen) totdat de orange markeringsstreepjes volledig in verticale stand zijn Controleer of de horizontale positieregeling (tevens 5x schakelaar) ingedrukt is.
5. Draai de intensiteitsregeling (links boven) geheel naar rechts (instrument is nu ingeschakeld) en laat het instrument opwarmen.



PLAQUETTE TELEQUIPMENT – MISE EN ROUTE D61A – CONSEILS DE MISE EN SERVICE

Afin de faciliter la mise en service de cet oscilloscope, nous vous recommandons de procéder comme suit:

1. Engager les commutateurs à glissière vers le haut.
2. Mettre le commutateur 'EXT/CH1/CH2' en position 'CH1'.
3. Tirer la commande 'Trig Level'.
4. Placer les réglages de position (↓) et (↔) à mi-course (repères orange verticaux). S'assurer que la commande de position horizontale (également expasseur X5) est enclenchée.
5. Tourner la commande 'Intensity' à fond vers la droite (intensité maximale) et laisser chauffer l'appareil quelques minutes.



BEDIENUNGSKARTE D61A

Diese Bedienungskarte soll bei der ersten Inbetriebnahme eine kleine "Hilfestellung" geben. Beachten Sie bitte die folgenden Punkte:

1. Setzen Sie alle vertikalen Kippschalter nach oben.
2. Stellen Sie den horizontalen Kippschalter auf CH1.
3. Ziehen Sie den Knopf TRIG LEVEL.
4. Stellen Sie die vertikalen und horizontalen Positionseinsteller so ein, dass die orangefarbenen Markierungsstriche senkrecht stehen.
5. Schalten Sie das Gerät ein, indem Sie den Drehknopf INTENSITY aus seiner Rasterstellung nach rechts bewegen. Warten Sie eine kurze Zeit (Aufwärmzeit).



ISTRUZIONI OPERATIVE DEL MODELLO D61A

Al fine di aiutarVi nel primo modo di impiego di questo oscilloscopio, suggeriamo di seguire la seguente procedura:

1. Porre tutti i commutatori a levetta in alto.
2. Porre il commutatore a levetta orizzontale su CH 1.
3. Tirare il comando livello di sincronismo.
4. Ruotare i comandi di posizione ↓ (verticale) ed ↔ (orizzontale) in modo che i riferimenti arancione siano a metà corsa. AssicurateVi che il comando di posizione orizzontale (che è anche commutatore X5) sia premuto.
5. Ruotare il comando Luminosità tutto in senso orario ed attendere alcuni minuti che lo strumento si riscaldi.



D61A Handledning

För ått hjälpa Er när Ni första gången ska använda Ert oscilloscope föreslår vi att Ni följer nedanstående punkter.

1. Ställ samtliga vertikala switchar i läge upp.
2. Ställ den horisontala switchen i läge CH1.
3. Drag ut ratten för TRIG LEVEL.
4. Vrid rattarna för vertikala ↓ och horisontala ↔ positionerna, så att den orange markeringen är lodrät (från centrum och uppåt). Kontrollera att ratten horisontala positionen är intryckt.
5. Vrid ratten INTENSITY max medurs och låt instrumentet varmas upp.



D61a START INSTRUKTION

For at lette forståelsen og første start af instrumentet, anbefaler vi nedenstående procedure:

1. Sæt alle lodrette omskiftere i deres øverste stilling.
2. Sæt den vandrette omskifter til kanal 1.
3. Træk TRIG LEVEL kontrol ud.
4. Drej positionskontrollerne for både vertikal og horisontal position således, at de orange mærker står lodret. Kontroller samtidig, at den horisontale positionskontrol er trykket ind.
5. Drej intensitetskontrollen helt med uret, og vent på at instrumentet varmer op.



INSTRUCCIONES DE FUNCIONAMIENTO DEL OSCILOSCOPIO D61A

Con el objeto de ayudarle a una fácil puesta en marcha de éste osciloscopio, nosotros le sugerimos es siguiente proceder:

1. Coloque todos los selectores deslizantes hacia arriba.
2. Coloque el selector de deslizamiento horizontal en CH1.
3. Saque hacia afuera el control de "Trig Level".
4. Gire los controles de posición vertical y horizontal para que las rayas naranjas estén colocadas en posición vertical. Asegúrese de que la Horizontal Position (también expensor X25) esté introducido hacia adentro.
5. Gire el control de intensidad totalmente hacia las agujas del reloj y permita que el instrumento alcance la temperatura necesaria.



INSTRUÇÕES DE OPERAÇÃO DO D61A

Procedimentos recomendados para a primeira operação deste osciloscópio:

1. Coloque na posição superior todos os comutadores de accionamento vertical.
2. Desloque o comutador de accionamento horizontal para CH1.
3. Accione para a posição mais saída todos os controles de nível de disparo (TRIGGER LEVEL).
4. Rode os controles vertical ↓ e horizontal ↔ de forma a que a marca laranja fique vertical. Assegure-se que o control de posição horizontal não está para fora (comutador X5).
5. Rode o controle de Intensidade para a posição máxima no sentido dos ponteiros do relógio e espere o aquecimento do equipamento.



7. Juster Intensity og Focus slik at De får en veldefinert stråle med passende intensitet.
8. Juster Trace Rotate (som er under håndtaket) slik at strålen blir horisontal.
9. Kople til det signal De ønsker å måle til CH1-inngangen. (Et passende signal er CAL Output, dvs. den innebyggede kalibrator).
10. Velg en passende følsomhet Volt/div. og Time/div., slik at De får en kurve som står stille med passende høyde og bredde.

6. Centralise trace with the \updownarrow (Vertical) and \leftrightarrow (Horizontal) position controls.
7. Adjust INTENSITY and FOCUS to obtain a well defined line of suitable intensity.
8. Adjust the TRACE ROTATE for a horizontal line.
9. Connect an input signal to CH1 input (a suitable signal is the CAL output). Switch VOLTS/DIV and TIME/DIV switches to give a locked display of a convenient signal amplitude and period. (These would be 0.1 V/div and 5 ms/div for the CAL output).

6. Centrer la trace à l'aide des commandes de position horizontale et verticale.
7. Régler les commandes d'intensité ('Intensity') et de focalisation ('Focus') pour obtenir une représentation satisfaisante.
8. Régler l'alignement horizontal de la trace à l'aide de la commande 'Trace Rotate' (située sous la poignée).
9. Connecter un signal à l'entrée Voie 1 ('CH1'), par exemple le signal 'CAL' et choisir un facteur de déflexion (Volts/Div) et la vitesse de balayage (Time/Div) permettant d'obtenir une représentation stable, d'amplitude et de largeur satisfaisantes (pour le signal 'CAL' régler à 0.1 V/Div et 5ms/Div).

6. Centraliseer de beide lijnen met behulp van de verticale en horizontale positieregelingen (buitenste knop van Volts/Div. en Time/Div. knoppen).
7. Draai de intensiteits- en focusregelingen totdat een gefocuseerde lijn van voldoende intensiteit is verkregen.
8. Indien noodzakelijk, de lijn afregelen met het duimwielje ("trace rotate") onder de draagbeugel.
9. Sluit een signaal aan op kanaal 1 (een bruikbaar signaal is dat van de calibrator). Kies nu de meest geschikte Volts/Div. en time/Div. standen voor een golfvorm van bruikbare amplitude en periode (voor het uitgangssignaal van de calibrator is dit 0.1V/div. en 5msec./div.)

6. Centrare sullo schermo il tracciato mediante i comandi verticale ed orizzontale.
7. Regolare i comandi di Luminosità e Fuoco per ottenere sullo schermo un tracciato ben definito.
8. Regolare il comando - levetta di rotazione della traccia (situato sotto la maniglia) per un corretto allineamento della stessa con il reticolo.
9. Applicare un segnale all'ingresso del canale CH1 (un segnale è disponibile all'uscita del calibratore). Agendo sui comandi Volt/DIV et Tempo/DIV, ottenere sullo schermo un tracciato stabile di ampiezza e durata desiderati. (Usare 0.1 V/DIV e 5 msec/DIV se si applica il segnale di uscita del calibratore).

6. Bringen Sie den Ablenkstrahl mit Hilfe der horizontalen und vertikalen Positionseinsteller ins Zentrum des Rasters.
7. Stellen Sie mit Hilfe der Bedienungselemente INTENSITY und FOCUS einen gut fokussierten Ablenkstrahl mit ausreichender Helligkeit ein.
8. Benutzen Sie, falls notwendig, das Justierelement TRACE ROTATE dazu, die Strahlspur parallel zu den horizontalen Rasterlinien auszurichten.
9. Schliessen Sie ein Signal an den Eingang CH1 INPUT und wählen Sie mit Hilfe der Stufenschalter VOLTS/DIV und TIME/DIV den entsprechenden Spannungs- und Zeitbereich.

6. Stil strålen med positionskontrollerne i midten af skærmen, både vertikalt og horisontalt.
7. Juster intensitet og focusering til et rimeligt lys og så skarp en stråle som muligt.
8. Juster trace rotate, så strålen følger de vandrette linier på skærmen. (Denne knap placeret under håndtaget).
9. Tilslut et signal til kanal 1 input (et brugbart signal kan f.eks. være CAL). Omskifterne Volt/Div. og Time/Div. drejes således, at man får et fastlåst og rimeligt billede både i amplitude og periode. (Dette vil eventuelt blive 0,1V/div. og 5ms/div., hvis man bruger CAL output).

6. Centrera strålarna på bildskärmen med vertikala och horisontala positionsrattarna.
7. Justera ljusstyrkan och skärpan i strålarna med rattarna INTENSITY och FOCUS till lämpligt värde.
8. Justera med spaken TRACE ROTATE som finns under borten delen av handtaget så att strålarna blir parallella med rutnätet.
9. Anslut signalen som ska mätas till ingången CH1 och ställ in storleken på signalen med omkopplaren VOLTS/DIV samt sveptiden med omkopplaren TIME/DIV.

6. Centralize o traço com os controles vertical e horizontal.
7. Ajuste a intensidade (INTENSITY) e a Focagem (FOCUS) de forma a obter um traço focado e com a intensidade conveniente.
8. Ajuste o controle de Rotação de Traço (TRACE ROTATE) (situado debaixo da pega de transporte) de forma a obter um traço horizontal.
9. Ligue um sinal à entrada CH1 (um sinal possível é a saída do calibrador CAL). Accione os comutadores VOLTS/DIV e TIME/DIV de forma a representar o sinal com as amplitudes e período convenientes (no caso de utilizar a saída CAL coloque os comutadores em 0,1 V/div e 5 m sec/div).

6. Centralice el trazo con los controles verticales y horizontales.
7. Ajuste los controles de intensidad y foco para obtener un perfecto enfoque y suficiente brillo del trazo.
8. Ajuste la rotación de trazo "Trace rotation" para conseguir la perfecta horizontalidad con respecto a la graticula de las trazas.
9. Conecte una cierta señal (una señal recomendable es la misma de calibración "CAL OUT") a la entrada del CH1 y seleccione los controles de Volts/div y Time/div en las posiciones correctas para conseguir la visualización y posible medida de la amplitud y tiempo. (Ello será cuando Vd. seleccione 0'1V/div y 5mseg/div con la señal de CAL).

ACCESSORIES AVAILABLE AS EXTRAS

The following accessories are available to enable customers to extend the use of their D61A.

Accessory	Part Number (for ordering)
Front protection cover	01-0617-00
Probe type TP1 (X1 attenuator)	
4.5 foot cable	010-0274-00
9.0 foot cable	010-0274-02
Probe type TP2 (X10 attenuator)	
4.5 foot cable	010-0270-00
6.0 foot cable	010-0270-02
10.0 foot cable	010-0270-03
Probe type TP5 (X1 – X10 attenuator)	010-0279-00

For Service Manuals Contact
MAURITRON TECHNICAL SERVICES
8 Cherry Tree Rd, Chinnor
Oxon OX9 4QY
Tel:- 01844-351694 Fax:- 01844-352554
Email:- enquiries@mauritron.co.uk

CONTENTS

SECTION	Page	SECTION	Page
1 SPECIFICATION		3 CIRCUIT DESCRIPTION	
Cathode Ray Tube (CRT)	1/1	Attenuator and Vertical input amplifier	3/1
Cooling	1/2	C.R.T. Circuit and Power Supply	3/2
Horizontal Deflection		Horizontal amplifier	3/2
External Horizontal amplifier	1/1	Vertical Output Amplifier	3/1
Sweep rates	1/1	Timebase, Unblanking and Bright line	
Outputs Front Panel		auto circuit	3/1
Calibrator	1/2	Trigger circuit	3/2
Probe test	1/2		
Power Supply		4 MAINTENANCE AND RE-CALIBRATION	
Consumption	1/2	Calibration Procedure	
Supply frequency	1/2	Astigmatism and Geometry	4/2
Supply voltages	1/2	Horizontal Amplifier	4/2
Size	1/2	Initial setting	4/1
Temperature limits	1/2	Internal calibrator	4/3
Trigger		Supply line voltages	4/1
Coupling	1/2	Trigger and sweep	4/3
Level	1/2	Vertical amplifier	4/2
Sensitivity	1/2	Introduction	
Source	1/2	Calibrator	4/1
Vertical Amplifier		General	4/1
Bandwidth	1/1	Tools and Equipment	4/1
Deflection factors	1/1	Mechanical	
Operating modes	1/1	Access to interior	4/1
X - Y	1/1	C.R.T. removal	4/1
Weight	1/2	Re-fitting C.R.T.	4/1
		Replacing intensity or focus controls	4/1
2 OPERATING INSTRUCTIONS		5 COMPONENT LIST	
Additional facilities — Use of		Electrical components	5/2
AC — TV	2/3	Mechanical parts	5/8
Slope	2/3		
Trigger source	2/3	6 CIRCUIT DIAGRAMS	
Trig level	2/3		Figure
Basic applications		Power Supply and C.R.T.	5
Correction-formula for fast		Printed Circuit Board PC156	7
rise time waveforms	2/5	Sweep Generator	4
Frequency measurement	2/4	Time/Div Switch)	
Instantaneous voltage measurement with		Volts/Div Switch)	6
reference to a DC voltage	2/4	Trig Input and Horizontal Amplifier	3
Instantaneous voltage measurement with		Volts/Div Switch and Vert Input amplifier	
reference to ground	2/4	CH1	1A
Monitor or display — Use as	2/3	CH2	1B
Peak to Peak voltage measurement	2/3	'Y' Amplifier	2
Rise time measurements	2/4	Pre Set Controls diagram)	
Voltage measurement between two		Printed Circuit boards) at end of chapter	
points on a waveform	2/4		
First time Operation			
Setting the controls	2/2		
Switch on	2/2		
Operation of Controls			
C.R.T.	2/1		
Horizontal	2/1		
Vertical	2/1		
Pre Operational check	2/1		

For Service Manuals Contact
MAURITRON TECHNICAL SERVICES
 8 Cherry Tree Rd, Chinnor
 Oxon OX9 4QY
 Tel:- 01844-351694 Fax:- 01844-352554
 Email:- enquiries@mauritron.co.uk

SECTION 1

SPECIFICATION

1.1 CATHODE RAY TUBE (CRT)

Display area	8 x 10 cm
Phosphor	P31
Standard	P7
Special order	
Overall accelerating potential	3.5 kV

For Service Manuals Contact
MAURITRON TECHNICAL SERVICES
 8 Cherry Tree Rd, Chinnor
 Oxon OX9 4QY
 Tel:- 01844-351694 Fax:- 01844-352554
 Email:- enquiries@mauritron.co.uk

1.2 VERTICAL AMPLIFIERS

Operating Modes	Channel 1 Channel 2 Channels 1 & 2 Alternate (at time/div speeds between 1 ms and 0.5 μ s) Chop (100 kHz approx. at time/div between 500 ms and 2 ms and on EXT X) X - Y
Bandwidth (-3 db)	
DC coupled	DC - 10 MHz
AC coupled	2 Hz - 10 MHz
Risetime	\leq 35 ns
Max. amplitude	8 div at low frequency decreasing to 5 div at 10 MHz.
X - Y	Vertical CH1 with CH2 input selected via TIME/DIV switch as horizontal amplifier
Bandwidth (-3 db)	DC - 1 MHz
Deflection factors	
Calibrated (9 ranges 1, 2 & 5 sequence)	10 mV/div - 5 V/div \pm 5%
Input impedance	1 M Ω and 35 pF in parallel
Maximum input	400 V peak

1.3 HORIZONTAL DEFLECTION

Sweep rates (19 ranges 1, 2 & 5 sequence)	
X1	500 ms - 0.5 μ s/div \pm 5%
X5	100 ms - 200 ns \pm 7%
	100 ns/div \pm 10%
External horizontal amplifier	
Bandwidth -3 db	2 Hz - 1 MHz
Deflection factor	200 mV/div approximately
Input impedance	1 M Ω and 15 pF in parallel

1.4 TRIGGER

Level	Variable or Variable limited with auto free running in absence of trigger signal
Coupling	AC or TV field for sweep ranges up to 100 μ s/div and TV line from 50 μ s/div to 0.5 μ s/div
Source	CH1, CH2 or external. All positive or negative
Sensitivity	
Internal	
40 Hz - 1 MHz	0.5 div minimum amplitude required becoming 1 div at 10 MHz
External	
40 Hz - 1 MHz	100 mV minimum amplitude required
1 MHz - 10 MHz	1 V minimum amplitude required

1.5 OUTPUTS FRONT PANEL

Calibrator peak to peak	500 mV squarewave $\pm 2\%$ at supply frequency.
Probe test	2.5 V approximately rectangular pulse at sweep repetition rate and sweep width.

1.6 POWER SUPPLY

Supply Voltages	The instrument will operate at any selected one of the following voltages 107 V $\pm 10\%$ 117 V $\pm 10\%$ 214 V $\pm 10\%$ 234 V $\pm 10\%$
Supply frequency	48 - 440 Hz
Consumption	25 VA

1.7 SIZE

Height	280 mm
Width	160 mm
Depth	420 mm

1.8 WEIGHT

8 kgs

1.9 COOLING

Convection

1.10 TEMPERATURE LIMITS, ambient

Operating	- 15 to +40° C
Non-operating	- 25 to +70° C

SECTION 2

OPERATING INSTRUCTIONS

2.1 PRE OPERATIONAL CHECK

2.1.1 GENERAL

Although this instrument is robust and is subjected to stringent checks before leaving our factory, it should be checked externally for possible damage. In the case of damage contact the carriers and your local Tektronix field office immediately.

Before switching the instrument on it is generally recommended that this section of the manual is read right through and that some time be spent in becoming familiar with the controls but experienced oscilloscope users might find the instructions in paragraph 2.4 rather laborious so it is left to the individual user to decide what to omit reading.

The D61A relies on convection cooling and care should be taken to see that external air circulation is not restricted.

2.1.2 SUPPLY VOLTAGE ADJUSTMENT

Before operating the instrument it is necessary to adjust for the available ac supply by means of the voltage selector plug, on the rear panel. Provision is made for selecting 107V, 117V, 214V and 234V. The plug should be set to the nearest voltage to the available supply which should be within 10% of the tapping selected. The selector is set by pulling out the plug and rotating until the selected voltage is opposite the indicator mark. The plug should then be pushed back into the socket.

2.1.3 SUPPLY FUSE

The fuse holder is situated on the printed circuit board inside the rear cover and if it is necessary to change the supply tapping then the fuse should be checked for correct rating. For operation on 107V or 117V a 500mA fuse should be fitted and on 214V or 234V the fuse should be 250mA. To gain access to the fuse holder it is necessary to remove the rear cover (see paragraph 4.2.1).

BEFORE REMOVING THE REAR COVER DISCONNECT THE INSTRUMENT FROM THE SUPPLY

2.1.4 SUPPLY CABLE (OR POWER CORD)

One of two types of supply cable will be fitted to the instrument. For the American continent a lead with a moulded three pin plug will be supplied. For the rest of the world the three core lead has short tails left for connecting to a plug top suitable for connection to the local supply system. The cores of this cable are colour coded as follows.

LINE	Brown
NEUTRAL	Blue
EARTH	Green/Yellow

For safety reasons it is important that the earth wire is connected and if an extension lead is used it is essential that there is earth continuity.

2.2 OPERATION OF CONTROLS

2.2.1 C.R.T. INTENSITY

Varies the display intensity. An instrument ON/OFF switch is fitted to this control.

FOCUS

Controls the display definition.

TRACE ROTATION

This control is fitted on top of the instrument under the rear handle end piece. It allows the trace to be aligned with the horizontal graticule lines.

2.2.2 VERTICAL VOLTS/DIVISION

Provides attenuation of the input signal in 9 calibrated steps. In the X - Y mode, CH1 provides the vertical input and CH2 the horizontal input.

POSITION

Moves the respective trace in the Y or vertical axis. A channel ON/OFF switch is fitted to this control.

AC/DC/GND

This selects the input coupling. In the AC position a capacitor is in series with the input, whilst in the DC position the signal is coupled directly to the attenuator. In the GND position the input is disconnected and the amplifier input is grounded. This allows a 0 V dc level to be established.

2.2.3 TRIG (Pick off)

The slide switch is used to select channel 1, channel 2 or an external source to provide a triggering pulse (see 2.2.4 below).

2.2.4 HORIZONTAL TIME DIVISION

Selects the sweep speed, there being 19 calibrated steps in the range 500 ms/division to 0.5 μ s/division. Also EXT X or CH2 (X - Y) MODE can be selected. On EXT X and sweep speeds between 500 ms/division and 2 ms/division the display chops between channels at approximately 100 kHz/sec. On sweeps speeds between 1 ms/division and 0.5 μ s/division the display alternates between channels.

X5

When the X5 switch is pulled out the sweep speeds are magnified by a factor of 5 and therefore the sweep range becomes 100 ms/division to 100 ns/division.

POSITION

The X POSITION control uses the

same knob as the speed magnifier. When it is rotated it moves the trace in an X or horizontal axis.

AC/TV

Triggering is normally AC coupled but when TV is selected triggering is from a TV field at sweep speeds of 0.5 s/division to 0.1 ms/division and from a TV line at sweep speed of 50 μ s/division to 0.5 μ s/division.

EXT-CH1-CH2

Enables the sweep to be triggered either externally or internally from either channel of vertical amplifier.

+ -

This switch allows triggering on a positive or negative slope of an input waveform. On the TV position + refers to a positive going picture signal and - to a negative going picture signal.

TRIG LEVEL

The level control selects the voltage level of the input waveform at which the sweep starts. With the knob pulled out the AUTO position is selected. In this position the range of level control is restricted to a total of 2.5 divisions. In the absence of an adequate trigger signal the sweep generator free runs providing a stable reference trace.

2.3 INPUT AND OUTPUT SOCKETS

CH1 } INPUT
CH2 }

These sockets connect the input signal to the respective vertical amplifiers.

TRIG/EXT X

The socket connects either a triggering or EXT X signal to the trigger or horizontal circuits, dependant on the TIME/DIV switch position.

Z MOD

Situated on the rear panel and connected via an isolating capacitor to the grid of the CRT. A positive going signal is necessary to intensify the trace with 10 V amplitude providing a good contrast. A negative going signal of similar amplitude will blank the trace.

CAL

A squarewave of 500 mV amplitude at supply frequency is provided at this socket to allow for the checking of the calibration of the Vertical channels or for triggering the sweep at supply frequency.

PROBE TEST & probe compensation

Provides a rectangular pulse at timebase frequency to facilitate the setting up of probes. To set up the probe compensation operate as follows:-

1. Connect the probe to the input socket of the channel with which it is to be used and set the EXT-CH1-CH2 switch to the other channel.
2. The TRIG LEVEL control should be turned fully anti-clockwise and pulled out to the AUTO position.
3. The TIME/DIVISION control should be set to 500 μ s/division.

For Service Manuals Contact
MAURITRON TECHNICAL SERVICES
8 Cherry Tree Rd, Chinnor
Oxon OX9 4QY
Tel: 01844-351694 Fax: 01844-352554
Email: enquiries@mauritron.co.uk

4. The appropriate VOLTS/DIVISION control should be set to 0.05 V/division.
5. The probe tip should be applied to the PROBE TEST socket and the probe trimmer adjusted so that the leading corner of the display is free from under or over shoot. The illustration below shows three conditions:
 - (a) over compensated;
 - (b) correctly compensated;
 - (c) under compensated.

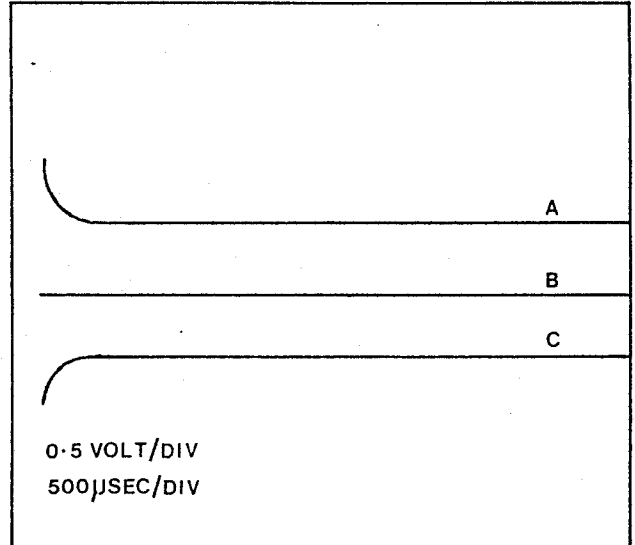

GND

This is connected to the chassis of the instrument.

2.4 FIRST TIME OPERATION

2.4.1 SETTING THE CONTROLS

Set the front panel controls as follows:-

INTENSITY	fully anti-clockwise - OFF
FOCUS	Central
CH1 } VOLTS/DIV	0.1 V
CH2 } AC-DC-GND	DC
CH1 Y POSITION	Central
CH2 Y POSITION	Fully anti-clockwise (should click off)
EXT/CH1/CH2	CH1
TIME/DIV	10 ms
POSITION	in and central
TRIG LEVEL	in and central
AC-TV	AC
+ -	+

Connect the CAL 0.5V socket (4mm) to input socket 1. For this operation a lead of 75 Ω Co-axial cable is required with a BNC plug at one end and a 4 mm plug at the other. It should be possible to construct such a lead using locally available parts but in case of difficulty contact your local TEKTRONIX field office.

2.4.2 SWITCH ON

1. Switch on by turning the INTENSITY control clockwise.
2. Allow a short while for a trace to appear.
3. Centralize the trace using the X and Y (CH1) POSITION controls.
4. Adjust the INTENSITY control so that the trace is at a suitable viewing intensity.
5. Adjust the FOCUS control for the sharpest obtainable trace.
6. Adjust the CH1 Y POSITION control so that the lower edge of the trace is level with one of the three lower graticule lines.
7. Observe that the overall waveform occupies 5 full vertical divisions of the graticule.
8. Switch CH1 VOLTS/DIV switch to 0.2 V.
9. Observe now that the trace will only occupy 2½ vertical division of the graticule.
10. Disconnect the input from CH1 INPUT leaving only a reference trace, which can be aligned with the graticule lines by using the TRACE ROTATION control, which is the lever sticking out of the top of the instrument, under the rear handle end piece.
11. Connect the input plug to CH2 INPUT.
12. Set the EXT-CH1-CH2 switch to CH2.
13. Switch on CH2 by rotating CH2 Y POSITION control clockwise until a click is heard. Further rotation will move the trace up the screen.
14. Set the lower edge of the trace to a suitable reference line and observe that the trace occupies 5 full vertical divisions.
15. Turn the CH1 POSITION control fully anti-clockwise to the OFF position and note that CH2 trace brightness increases. Leave CH1 off.
16. By now the user will be conversant with the operation of the Y or vertical controls so now they should turn to the sweep controls. By turning the TIME/DIV control anti-clockwise in steps as far as it will go, it should be noticed that the sweep speed decreases.
17. Set the TIME/DIV knob to 1 ms and observe the number of cycles.
18. Set the TIME/DIV knob to 10 ms and note that more cycles of the waveform should be seen.
19. Pull out the X5 control and observe that the display should be double that in 17 above.

2.5 USE OF ADDITIONAL FACILITIES

2.5.1 TRIGGER SOURCE

We have been using the control in the INT position but it is possible to trigger from an external signal by plugging the signal into the TRIG/EXT X socket. The EXT-CH1-CH2 switch should be set to EXT.

2.5.2 SLOPE (+ or -)

The + - switch allows triggering from a positive (+) going or negative (-) going portion of the trigger signal. This is important when it is only required to observe a portion of a waveform but where several cycles of a waveform are displayed the setting is often unimportant.

2.5.3 AC-TV

For the inspection or measurement of most waveforms the AC-TV control is used in the AC position. For the inspection of TV field or TV line waveforms the switch should be set to TV, and the + - switch to + for positive going picture signals or - for negative going picture signals. For TV field waveforms sweep ranges of 0.5 sec/div to 0.1 ms/div should be used. For TV line waveforms sweep ranges of 50 µs/div to 0.5 µs/div are required. In the TV position the Level control is inoperative but the Auto position still gives a trace in the absence of a TV signal of sufficient amplitude to trigger the oscilloscope.

2.5.4 TRIG LEVEL

There are two modes of LEVEL control operation. In the normal (control IN) position the triggering point can be varied over the whole of the waveform to a maximum of 8 divisions for a symmetrical waveform.

In the AUTO position (control OUT) level control is restricted to approximately 2½ divisions, and the timebase

free runs in the absence of a trigger signal.

2.6 BASIC APPLICATIONS

The following are typical applications of oscilloscope type D61A. Only outline procedures are given to allow the user to adapt the method to individual requirements. Familiarity with the controls of the instrument as outlined in 2.2, 2.3 and 2.4 should allow these basic techniques to be applied to a wide variety of uses.

2.6.1 USE AS A MONITOR OR DISPLAY

One of the most frequent uses of an oscilloscope is as a monitor or display. By correct adjustment of the X and Y controls it is possible to display many cycles or a fraction of one cycle of a repetitive waveform. Generally it is desirable to limit the display to the centre 6 divisions vertically and in the case of a repetitive waveform to display 1 to 8 cycles within the centre 8 divisions horizontally. It is possible to use the D61A instrument in this way to inspect a waveform for slope, over or undershoot and ringing. Where it is required to compare two waveforms, such as the waveforms entering and leaving a device, it is possible to feed the two waveforms to the two channels and display them either vertically one above the other, or superimposed.

2.6.2 PEAK TO PEAK VOLTAGE MEASUREMENT

AC - Symmetrical waveform

1. Connect the waveform to be measured to CH1 or CH2 INPUT.
2. Set the appropriate VOLTS/DIV switch to display about 5 or 6 divisions of the waveform.
3. Set the AC-DC-GND switch to AC.
4. Set the TIME/DIV switch to display several cycles of the waveform.
5. Use the Y POSITION control to set the lower edge of the waveform on one of the lower graticule lines and so that the top edge of the waveform is in the graticule area.
6. Measure the vertical amplitude (div) of the signal on the screen.
7. Multiply the amplitude in 6 above by the VOLTS/DIV setting and by the attenuation factor of any probe used.

EXAMPLE

Assume a vertical deflection of 5.3 division using a X10 attenuation probe and a VOLTS/DIV setting of 0.05 Volts per division.

$$\therefore \text{Peak to Peak Voltage} =$$

$$\text{Vertical deflection} \times \text{VOLTS/DIV (Setting)} \times \text{Attenuator factor (probe)}$$

for our example

$$\text{Peak to Peak voltage} = 5.3 \times 0.05 \times 10$$

$$\therefore \text{Peak to Peak voltage} = 2.65 \text{ Volts.}$$

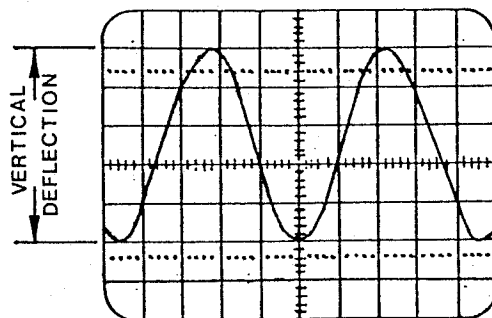

Measuring Peak to Peak Voltage of a Waveform

2.6.3 VOLTAGE MEASUREMENT BETWEEN TWO POINTS ON A WAVEFORM

Proceed as in 2.6.2 above substituting the two measurement points for the peaks and setting the lower point on one of the lower graticule lines.

2.6.4 INSTANTANEOUS VOLTAGE MEASUREMENT WITH REFERENCE TO GROUND

To make a measurement of the DC level at a specified point on a waveform use the following procedure.

1. Set the AC/DC/GND switch of the selected channel to DC.
2. Set the EXT/CH1/CH2 switch to the channel selected.
3. Pull the TRIG LEVEL control out to the AUTO position.
4. Connect the waveform to be measured to the INPUT of the selected channel.
5. If the waveform is repetitive use the TIME/DIV and X POSITION (\leftrightarrow) controls to display at least one cycle.
6. Switch the AC/DC/GND switch of the channel in use to GND.
7. Set the trace to the lowest graticule line or other suitable reference line, using the Y POSITION control, if the point to be measured is positive. Set to highest or other suitable graticule line if the point to be measured is negative. AFTER THIS DO NOT ADJUST THE Y POSITION CONTROL.
8. Set AC/DC/GND switch to DC.
9. Measure the distance in divisions from the reference line to the point to be measured.
10. Establish the polarity of the measured voltage. If the measurement point is above the reference line the voltage is positive. If the measurement point is under the reference line it is negative.
11. Multiply the estimate in (9) above by the VOLTS/DIV switch setting and any probe attenuation factor.

EXAMPLE

Assume that the vertical distance measured is +2.7 divisions with a VOLTS/DIV setting of 200 mV and the probe attenuation factor is X1

$$\begin{aligned} \therefore \text{Instantaneous voltage} &= \\ \text{Vertical distance} \times \text{Polarity} \times \text{VOLTS/DIV} \times \text{Probe Attenuator factor} & \end{aligned}$$

For the values given
Instantaneous voltage = $2.7 \times 1 \times 0.2 \times 1$

$$\therefore \text{Instantaneous Voltage} = 0.54 \text{ Volts}$$

2.6.5 INSTANTANEOUS VOLTAGE MEASUREMENT WITH REFERENCE TO A DC VOLTAGE

Proceed as in 2.6.4 but in step (6) set the switch to DC and feed in the reference voltage to the input. Step 8 will be to remove the reference voltage.

2.6.6 TIME DURATION MEASUREMENT

1. Connect the waveform to be measured, to CH1 or CH2 INPUT.
2. Set the VOLTS/DIV switch to display a suitable vertical amplitude of the waveform.
3. Set the TIME/DIV and Level controls to display the appropriate portion of the waveform to be measured over the maximum number of horizontal graticule divisions possible, keeping well inside the graticule limits.
4. Use the Y POSITION control to move the trace so that the measurement points are on the horizontal centre line.
5. The X POSITION control is used to move the start of the measurement period to a convenient reference point.
6. Measure the distance (divs) between the measure-

ment points.

7. Multiply the measurement in 6 above by the setting of the TIME/DIV switch and if the X5 control is used to divide by 5. This gives the time duration

EXAMPLE

If the distance between the points is 2.5 divisions with the TIME/DIV control on 0.2 ms/div and the magnifier is not used.

$$\text{Time duration} = \text{horizontal distance (divisions)} \times \text{TIME/DIV setting}$$

$$\therefore \text{Time duration} = 2.5 \times 0.2 \text{ ms}$$

$$\therefore \text{Time duration} = 0.5 \text{ ms}$$

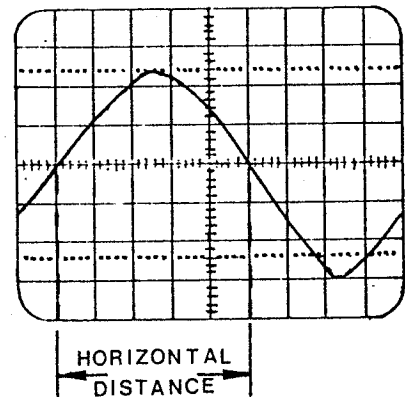

Measuring the Time Duration between points on a Waveform

2.6.7 FREQUENCY MEASUREMENT

The time duration technique shown in 2.6.6 can be used to establish the frequency of a periodically recurrent waveform. The start of two adjacent cycles is taken as the measurement points and the time duration between these points established. The frequency is the reciprocal of the time duration.

EXAMPLE

If one cycle occupies 5 divisions with the time division control on 0.2 ms/div and the X5 magnifier is used.

$$\text{Time duration} = \frac{\text{Horizontal Distance}}{\text{Magnification}} \times \text{TIME/DIV (setting)}$$

for the example

$$\begin{aligned} \text{Time duration} &= \frac{5 \times 0.2 \text{ ms}}{5} \\ &= 0.2 \text{ ms} \end{aligned}$$

$$\begin{aligned} \text{Frequency} &= \frac{1}{\text{Time duration}} \\ &= \frac{1}{0.2 \times 10^{-3}} \\ &= 5 \text{ kHz} \end{aligned}$$

2.6.8 RISE TIME MEASUREMENTS

Rise time measurements employ the same basic techniques as time duration measurements. Rise time t_r is the time required by the leading edge of a waveform to rise from 10% to 90% of the waveform amplitude. The procedure is as follows:—

1. Connect the waveform to either input
2. Set the AC/DC/GND switch of the channel being

3. used to the appropriate position.
4. Set the appropriate VOLTS/DIV switch to display 4 to 8 divisions amplitude
5. Centre the display about the centre horizontal line.
6. Set the trigger controls to obtain a stable display.
7. Set the TIME/DIV switch so that the 10% and 90% points of the waveform lie within the centre 8 divisions horizontally.
8. Determine the 10% point of the waveform and use the X and Y position controls to set this point to a convenient graticule point.
9. Determine the 90% point and estimate the horizontal distance in graticule divisions between the 10% and 90% points of the waveform.
10. Multiply the distance obtained in (8) by the setting of the time divisions switch. If the sweep magnifier is used divide the result by 5. If the result is close to the rise time of the instrument it is necessary to apply a correction factor (See below).

EXAMPLE

Assume that the horizontal distance between the 10% and 90% points is 5 divisions and the TIME/DIV switch is set to 100 ms and the sweep magnifier is used.

$$\text{Rise time} = \frac{\text{horizontal distance (divs)} \times \text{TIME/DIV setting}}{\text{sweep magnification}}$$

for the example

$$\text{Rise time} = \frac{5 \times 100 \mu\text{s}}{5}$$

$$\therefore \text{Rise time} = 100 \mu\text{s}$$

2.6.9 CORRECTION FORMULA FOR FAST RISE TIME WAVEFORMS

When the rise time of the oscilloscope is of the same order as the rise time of the waveform being measured it is necessary to apply a correction formula as follows:-

$$\text{Actual Rise time (tra)} = \sqrt{\left(\text{Measured Rise time (trm)}\right)^2 - \left(\text{Oscilloscope Rise time (tro)}\right)^2}$$

EXAMPLE

Assume the rise time found by the method given in 2.6.8 is 53.2 ns. The oscilloscope rise time is approximately 35 ns. Applying the formula

$$\begin{aligned} \text{Actual rise time} &= \sqrt{(53.2)^2 - (35)^2} \\ &= \sqrt{2830.24 - 1225} \\ &= \sqrt{1605.24} \\ &\cong 40 \text{ ns} \end{aligned}$$

NOTE It should not be necessary to apply the correction to waveforms having a rise time greater than 150 ns. Also the quoted rise time is the maximum figure and the actual rise time could be considerably better than this. This would mean that a calculated rise time would be in error. If it is necessary to work to great accuracy it would be necessary to measure the bandwidth of the instrument and calculate the rise time as follows:-

$$\text{Rise time} = \frac{0.350}{\text{Bandwidth (MHz)}} \text{ ns}$$

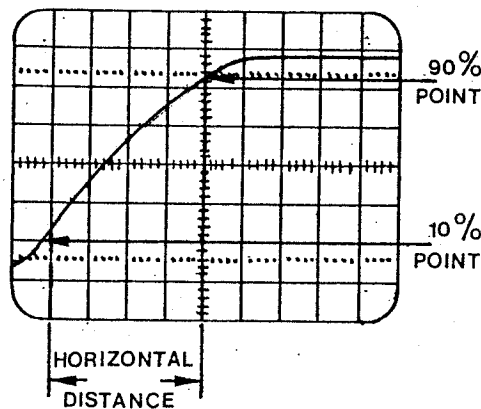

Measuring Rise Time.

For Service Manuals Contact
MAURITRON TECHNICAL SERVICES
 8 Cherry Tree Rd, Chinnor
 Oxon OX9 4QY
 Tel:- 01844-351694 Fax:- 01844-352554
 Email:- enquiries@mauritron.co.uk

SECTION 3

CIRCUIT DESCRIPTION

3.0 ATTENUATOR AND VERTICAL INPUT AMPLIFIER Figures 1A & 1B.

CH1 and CH2 are identical and the following description covers both channels.

The input to the attenuator is connected via C901 to the input socket SK901 on AC, directly to the input socket on DC or to ground on GND. The capacity compensated attenuator is switched by S902 wafer 1 in steps of 100, 10 and 1 and the output is fed to the gate of TR601 via C601 and R602 which, together with D601, protect the input against overloads up to ± 400 V. TR601 is a F.E.T. source follower whose output DC level is adjusted to zero by R604 and R608. The output is then attenuated in steps of 5, 2 and 1 selected by S902 wafer 2 F and fed to the base of TR603 which together with TR604 forms a longtailed pair. The diodes D602 and D603 in the emitters increase the signal handling capacity without affecting the change in gain which remains directly proportional to current and, therefore, to supply voltage. This compensates for the CRT sensitivity which is inversely proportional to supply voltage and hence the overall vertical sensitivity remains independent of supply voltage. Vertical shift is fed to the base of TR604. The gain of the channel is set up by R613 which controls the total stage emitter current. The collector currents of TR603 and TR604 pass through thermal compensating networks R611, C602 and R614, C603 and also through grounded base stage TR602 to the output stages. TR602 isolates the channel switching waveforms from the input circuit.

3.1 VERTICAL OUTPUT AMPLIFIER

Figure 2

The collector currents of the selected channel pass through diodes D637 and D638 for Channel 1, or D642 and D643 for Channel 2, to the bases of shunt feedback stages TR633 and TR636. The output of TR633 and TR636 are fed to the bases of TR634 and TR635, a longtailed pair whose collectors feed the Y plates of the CRT. C641 and R671 in the emitter circuit are adjusted for the best pulse response and TH631 compensates for the temperature coefficient of the input stages. The appropriate channel is selected either manually by S631 and S632 which are ganged to the vertical shift controls, or automatically by the Chop/Alternate circuit TR631 and TR632. On EXT X and Time/Div speeds of 2 ms/div and slower, TR631 and TR632 operate as a free-running multivibrator at a frequency of approx. 100 kHz. When TR632 conducts D635 and D636 conduct and turn off D637 and D638 thus disconnecting Channel 1. Conversely when TR631 conducts D639 and D641 conduct and turn off D642 and D643 thus disconnecting Channel 2. C632 and C634 feed pulses to the unblanking amplifier to blank out the trace during the transitions. On Time/Div speeds above 2 ms/div, TR631 and TR632 operate as a bistable whose state is changed at the end of each time base sweep by an edge from the emitter of TR34. The network L631, C640, R640 in CH1 and L632, C649, R669 in CH2 delay the transitions until the trace is blanked. The vertical output amplifier current supplies the +13 V line which is decoupled by C645 and also the +7.5 V line which is stabilized by zener diode D644. The +7.5 V is used as a reference for the -7.5 V line which is a shunt stabilizer circuit consisting of TR637, R659, R666, R667 and R668. R658 compensates for variations in the -13 V line and reduces the effect of supply voltage variations on the -7.5 V line.

3.2 TRIGGER CIRCUIT Figures 3 & 4

This consists of a longtailed pair TR23 and TR25 similar to the Vertical Amplifier input stage but with temperature compensation in its emitter circuit. On the CH2 position the input is connected to CH2 and EXT X position via C20, C21 and R23 to the TRIG/EXT X socket. On all other positions of the Time/Div switch the input is connected to S20 which selects either the EXT TRIG socket, CH1 or CH2 signal. The output from the appropriate collector, selected either by the Polarity switch S21 or the Time/Div switch S1, is connected via diode D27 or D31 to the emitter of common base stage TR26. The collector of TR26 is connected via D54, D33 and D34 to the input of the Horizontal Amplifier on CH2 and EXT X positions of the Time/Div switch S1. On other positions of the Time/Div switch the collector of TR26 is AC coupled via D32 to the base of TR21, a shunt feedback stage.

On the AC position of S22 the output of TR21 is connected via diodes D58 and D59, which limit the voltage swing, to the input of the Schmitt trigger circuit TR22 and TR24. The Level control R21 allows the mean DC level of the output of TR21 to be varied so that any portion of the trigger signal can be set at the triggering level of the Schmitt. When the Level control is in the Auto position the range of the Level control is restricted by the addition of R20 in series with R22. This reduces the Level control range from more than 10 divisions to approximately 2.5 divisions. On the TV position of S22 the output of TR21 is connected via diode D57 to the sync separator TR38 which conducts only during the sync pulses and is cut off during the video signal. On Time/Div speeds of 100 μ s and slower the output of TR23 is integrated by R129 and C63. This gives a waveform where the field pulses are of greater amplitude than the line pulses and are fed via TR25 to the input of the Schmitt trigger circuit. On Time/Div speeds of 50 μ s and faster C63 is disconnected from ground by cutting off diode D56. The line and field pulses are then of equal amplitude and are fed via TR39 to the input of the Schmitt trigger circuit. On TV diodes D58 and D59 are cut off and the Level control is disconnected by switching R22 to -13V. The Schmitt trigger circuit TR22 and TR24 provides a constant amplitude trigger signal at the collector of TR24 to the timebase and bright-line auto circuit.

TR30 provides a positive going gating pulse to the base of TR24 to inhibit the Schmitt trigger circuit during the timebase sweep. This prevents trigger pulses being produced during the sweep and breaking through into the Vertical Amplifier. To prevent the triggering pulses which are produced by the gating waveform being fed to the bright-line AUTO circuit a negative differentiated pulse is fed from the collector of TR30 to the anode of D43 cutting it off before the arrival of the positive trigger pulse. The trigger pulse is thus prevented from reaching the bright-line circuit, triggering it and interrupting the free running of the timebase. The gating is removed on timebase speeds below 1 ms/div by removing the HT supply to TR30 by means of S1 - 2F.

3.3. TIMEBASE, UNBLANKING AND BRIGHT LINE AUTO CIRCUIT Figure 4

3.3.1 The differentiated positive pulse from the trigger circuit is fed via D36 to the base of TR27 which together with TR29 forms a bistable. The positive pulse turns on TR27 which in turn cuts off the clamping transistor TR34. The timebase, a F.E.T. Miller circuit, then runs up linearly charging up the hold-off capacitor via D47 and resetting the bistable via R114. When TR27 cuts off, TR34 con-

ducts and discharges the timing capacitor until D45 conducts and reduces the current in TR34 to the value required by the timing resistor. At this point the flyback stops. During the flyback the hold-off capacitor discharges through R114 until D48 conducts. At this point the action is complete and the timebase can be triggered by the next triggering pulse.

3.3.2 If the Trig level control is in the Auto position and no trigger pulses are present, TR34 and D49 conduct and reduce the potential at the anode of D48. This allows the hold-off capacitor to discharge further and re-trigger the bistable. The timebase then free-runs. If trigger pulses are present at the anode of D43 the positive pulses trigger the monostable TR32 and TR35. When triggered at frequencies above about 10 Hz the average collector current of TR35 is low and D49 is cut off returning the timebase to the normal triggered condition.

3.3.3 The collector current of TR29 which is cut off during the sweep is fed to the input of TR28. The collector of TR28 goes negative at the beginning of the sweep until diode D38 conducts and clamps the collector potential at about 3 V, thus unblanking the sweep. When TR29 conducts at the end of the sweep TR28 collector goes positive blanking the trace. On chop positions of the sweep negative edges from the chop circuit are fed to the base of TR28 to blank the trace during the transitions.

3.4 HORIZONTAL AMPLIFIER Figure 3

This consists of a shunt feedback stage TR31 with switched feedback resistors to give X5 expansion. The sweep and horizontal shift currents are mixed at the input of the shunt feedback stage and the output is fed to a longtailed pair, TR33 and TR37, which feeds the horizontal deflection plates of the CRT. D44 clamps the collector of TR33 and prevents it from bottoming.

On the EXT X and CH2 positions of the Time/Div switch the input of TR31 is switched to the collector of TR26 via D33, D34 and D54 and the X5 feedback resistor is shorted out by diodes D33, D34, D35 and D37. The trace is then deflected horizontally via the EXT X socket or from Channel 2. On these positions the gate of TR36

is connected to the cathode of D47 which clamps the output of the timebase at about +1 V and turns off TR29 thus unblanking the trace.

3.5 CRT CIRCUIT AND POWER SUPPLY

Figure 5

The supply voltage is fed via the power ON/OFF switch S401, the fuse FS401 and the voltage selector SK401 to the appropriate primary tapping on T401.

3.5.1 The -13 V line is obtained from a full wave rectifier circuit consisting of D405, D406, C402 and R403.

3.5.2 The +117 V line is obtained from a bridge rectifier D401, D402, D403 and D404 with reservoir capacitor C403 and smoothed by R406 and C408 to provide the +110 V line and by R407 and C406 to provide the +80 V line.

3.5.3 The -1050 V line is obtained from a half wave rectifier circuit consisting of D407, D409, C411 and C412.

3.5.4 The +2500 V line is obtained from a voltage doubler circuit consisting of D408, D409, C401 and C404.

3.5.5 The calibrator circuit provides a 0.5 V squarewave at supply frequency. It is produced by a diode switching circuit in which a current derived from the stabilized -7.5 V line is passed through D413 and R408 during negative half cycles of the AC voltage from the 13 V transformer winding. On positive half cycles D413 is cut off and the current passes through D412 and R402. The output voltage is set by R405. The temperature coefficient of the diode D413 is compensated for by the negative coefficient of the output resistor R408 giving an output voltage which is nominally independent of temperature.

3.5.6 The grid voltage of the CRT is derived from a zener diode connected between the CRT cathode and the -1050 V supply. The voltage is varied by the intensity control R301. The intensity of the trace may be varied by signals fed via the Z Mod socket SK301 and C301 to the grid of the CRT.

For Service Manuals Contact
MAURITRON TECHNICAL SERVICES
8 Cherry Tree Rd, Chinnor
Oxon OX9 4QY
Tel: 01844-351694 Fax: 01844-352554
Email: enquiries@mauritron.co.uk

SECTION 4

MAINTENANCE AND RE-CALIBRATION

Care must be taken not to touch high voltage tags. The instrument **MUST BE UNPLUGGED** when removing the case, removing or replacing the tube, or other components and where possible during other servicing.

4.1 INTRODUCTION

4.1.1 GENERAL

The solid state design of the instrument makes frequent adjustment of the internal preset components unnecessary. The appropriate part of the re-calibration procedure should be carried out, whenever the instrument fails to meet its specification, or whenever a defective component is replaced. Section 3 should be helpful in deciding which part of the circuit requires adjustment.

4.1.2 CALIBRATOR

The internal 0.5 V calibration signal allows the accuracy of the vertical amplifier system to be checked. The calibration signal which is at supply frequency can also be used to check the sweep speed to the accuracy of the supply frequency.

4.1.3 TOOLS AND EQUIPMENT

To carry out the whole calibration procedure, the following tools and equipment are required:—

Low-capacitance trimming tool (for preset capacitors).

Small screwdriver (for preset potentiometers).

Amplitude Calibrator, providing 1 kHz squarewave, amplitude 50 mV, amplitude accuracy within 0.25%.

Time-mark Generator, providing markers of 1 ms, 1 μ s and preferably, 0.5 μ s. Accuracy within 0.1%.

Squarewave Generator, providing outputs of 1 kHz and 10 kHz, 50 mV to 50 V.

Squarewave Generator, providing outputs of 10 kHz, 100 kHz and 1 MHz with rise-time less than 10 ns.

Coaxial cable and terminating resistor for the above.

Monitor Oscilloscope, complete with X10 passive probe, and having a sweep output socket.

Passive Probe, X10 attenuation, suitable for input capacities of 25 to 35 pF.

Test Meter, 20,000 Ω /volt or higher, accuracy within 2% 2.5 V DC to 2500 V DC.

Sinewave Generator, 1 kHz, 10 kHz and 50 kHz.

Coaxial leads allowing the same signal to be connected to Channel 1, Channel 2 and the EXT socket.

4.2 MECHANICAL

4.2.1 ACCESS TO INTERIOR

NOTE: UNPLUG INSTRUMENT FROM SUPPLY BEFORE REMOVING COVERS

The cabinet covers are removed as follows:—

1. The back cover is removed by undoing and removing the three fixing screws and pulling the cover off.

2. The lower side panels can then be slid backwards out of position.

To re-fit the covers it is necessary to slide the lower covers into position taking care that the slot on the lower edge engages with the raised portion of the lower panel bezel, and that the lug at the top is engaged. The rear cover should be slid into position and the three screws inserted.

4.2.2 CRT REMOVAL

1. Disconnect the instrument from the ac supply.
2. Remove the covers as shown in 4.2.1 above.
3. Short point k on the Printed Circuit board to chassis via a 1 M Ω resistor and keep the short in place for

about 1 minute to discharge any residual high voltage.

4. Remove the INTENSITY and FOCUS knobs.
5. Remove the felt washers and the panel bearing the name TELEQUIPMENT.
6. Remove the 4 screws fixing the plastic bezel surrounding the tube face and pull off the bezel and graticule.
7. Slide off the black section of the upper case by moving forward.
8. Spring down the ends of the springy copper strip above the tube and slide the strip out.
9. Pull off the tube base (at the rear of the tube) using the loop provided.
10. Loosen the screws holding the clamps which fix the rear tube screen to the plastic moulding and slide these clamps off.
11. Slide the tube gently forward easing the mumetal past the lower support and chassis edge until the PDA cap is clear of the chassis.
12. Remove the PDA cap by pulling out and then slide the tube right out of the instrument.

4.2.3 RE-FITTING CRT

The procedure for re-fitting is the reverse of 4.2.2 above. Care must be taken in easing the front of the mumetal screen past the chassis edge, and in keeping the PDA cap clear of the chassis front.

4.2.4 REPLACING INTENSITY OR FOCUS CONTROLS

If it is required to replace either of these controls it is necessary to remove the C.R.T. as above to allow enough room to get to the extension spindles and fixing nuts.

4.3 CALIBRATION PROCEDURE

4.3.1 INITIAL SETTING

1. Remove side covers, reference Para 4.2.1. Connect to a suitable A.C. power source and switch the instrument on.
2. Set the front panel controls as follows:—

AC-DC-GND)	GND
VOLTS/DIV)	CH1 & 0.01
POSITION)	CH2 Mid-position
TIME/DIV)	1 ms
Horizontal POSITION	Mid-position, push in
TRIG LEVEL	Mid-position, out (AUTO)
±	+
EXT-CH1-CH2	EXT
AC-TV	AC
FOCUS)	Adjust for well defined
INTENSITY)	low brilliance trace

4.3.2 SUPPLY LINE VOLTAGES (R668)

D.C. supply line voltages should normally lie within the prescribed limits when A.C. power source voltage coincides with the setting of the line voltage selector on the rear of the instrument.

The -7.5 V line is adjustable by means of R668, It should normally only require re-setting when TR637 has been replaced. Note however, that any adjustment of this line necessitates the carrying out of the entire Calibration Procedure as detailed in this Section.

Supply Line	Test Point	Limits
- 7.5V	CH1 POSITION potentiometer violet-blue wire	-7.3V to -7.7V
+ 7.5V	CH1 POSITION potentiometer orange-white wire	+7.1V to +7.9V
- 13V	Horizontal POSITION potentiometer mauve-white wire	-12.4V to -13.6V
+ 13V	Test Point 3	+11.9V to +12.1V
+ 80V	Test Point 22	+75V to +85V
+ 110V	Test Point 29	+107V to +117V
-1050V	Test Point 156/7	-1060V to -1160V
+2500V	Test Point 156/K	+2400V to +2500V

4.3.3 ASTIGMATISM AND GEOMETRY (R305 and R307)

1. Set TIME/DIV to 100 μ s and display a 10 kHz sinewave signal on one channel only at 6 divisions vertical amplitude.
2. Adjust FOCUS and R305 (Astigmatism) for best definition of display. Leave 10 kHz signal connected.
3. Set TIME/DIV to 1 ms.
4. Select AUTO and ensure that no signal is connected to EXT.
5. Set EXT-CH1-CH2 switch to EXT so that display becomes an unsynchronised raster.
6. Adjust R307 so that the raster becomes as nearly as possible rectangular.
7. Disconnect 10 kHz signal.

4.3.4 VERTICAL AMPLIFIER

4.3.4.1 CHANNEL 1 VOLTS/DIV BALANCE (R604 AND R608)

1. Check that Channel 1 input switch is set to GND and VOLTS/DIV to 0.01
2. Turn Channel 1 on, Channel 2 off.
3. Connect test meter between test point C3 and chassis.
4. Adjust R604 for zero reading. It should normally be necessary to adjust R604 only when TR601 has been replaced. After adjustment of R604, R613 must be checked and re-adjusted if necessary. See para 4.3.4.5. Disconnect test meter.
5. Switch Channel 1 VOLTS/DIV between 0.01, 0.02 and 0.05 positions. Adjust R608 to eliminate vertical movement of the trace.

4.3.4.2 CHANNEL 1 POSITION BALANCE (R618)

1. Connect test meter between Channel 1 POSITION potentiometer moving contact (red-blue wire) and chassis.
2. Adjust POSITION for zero reading.
3. Adjust R618 to bring the trace to the centre of the screen.
4. Disconnect test meter.

4.3.4.3 CHANNEL 2 VOLTS/DIV BALANCE (R704 AND R708)

1. Check that Channel 2 input switch is set to GND and VOLTS/DIV to 0.01.
2. Turn Channel 2 on and Channel 1 off.
3. Connect test meter between test point C33 and the chassis.
4. Adjust R704 for zero reading. It should normally be necessary to adjust R704 only when TR701 has been replaced. After adjustment of R704, R713 must be checked and re-adjusted if necessary. See para 4.3.4.6.
5. Disconnect test meter.
6. Switch Channel 2 VOLTS/DIV between 0.01, 0.02 and 0.05 positions. Adjust R708 to eliminate vertical movement of the trace.

4.3.4.4 CHANNEL 2 POSITION BALANCE (R718)

1. Connect test meter between Channel 2 POSITION potentiometer moving contact (red-blue wire) and chassis.
2. Adjust POSITION for zero meter reading.
3. Adjust R718 to bring the trace to the center of the screen.
4. Disconnect test meter.

4.3.4.5 CHANNEL 1 GAIN (R613)

1. Set Channel 1 VOLTS/DIV to 0.01 and Amplitude Calibrator output to 50 mV.
2. Display Amplitude Calibrator output on Channel 1.
3. Adjust the amplitude of the display to exactly 5 divisions with R613.
4. Disconnect Amplitude Calibrator.

4.3.4.6 CHANNEL 2 GAIN (R713)

1. Set Channel 2 VOLTS/DIV to 0.01 and Amplitude Calibrator output to 50 mV.
2. Display Amplitude Calibrator output on Channel 2.
3. Adjust the amplitude of the display to exactly 5 divisions with R713.
4. Disconnect Amplitude Calibrator.

4.3.4.7 PULSE RESPONSE (C641, R671 and R653)

1. Set both VOLTS/DIV to 0.01.
2. Display a 1 MHz squarewave signal simultaneously on both channels. (Ensure that the co-axial cable connecting the signal to the instrument is correctly terminated).
3. Adjust C641 and R671 to optimise squarewave response on both channels. If the response of the channels is not exactly the same, adjust for best compromise.
4. Adjust R653 to minimize the change in squarewave response occurring when either POSITION control is adjusted.
5. Disconnect squarewave signal.

4.3.4.8 ATTENUATORS (C902, C903, C904 and C905).

Channel 1 and Channel 2 attenuators and input selector circuits are electrically identical. Corresponding components in these parts of the two channels carry the same component references.

1. Set Channel 1 input switch to D.C.
2. Display a 10 kHz squarewave of 0.5 V amplitude on Channel 1, using the 0.1 VOLTS/DIV position of the attenuator.
3. Adjust C905 for the best response (square corner without overshoot or undershoot).
4. Set Channel 1 attenuator to 1 VOLTS/DIV and increase the amplitude of the squarewave to 5V.
5. Adjust C904 for the best response.
6. Disconnect squarewave signal.
7. Connect a X10 passive probe to the input of Channel 1.
8. Set the Channel 1 VOLTS/DIV to 0.01.
9. Display a 1 kHz squarewave of 0.5 V amplitude via the probe.
10. Adjust the probe compensation for the best squarewave response.
11. Set VOLTS/DIV to 0.1 and increase the amplitude of the squarewave to 5 V.
12. Without altering the probe compensation, adjust C903 for the best squarewave response.
13. Set VOLTS/DIV to 1 and increase the amplitude of the squarewave to 50 V.
14. Adjust C902 for the best squarewave response.
15. Disconnect signal and probe.
16. Repeat Ops 1 to 15 for Channel 2.

4.3.5 HORIZONTAL AMPLIFIER

4.3.5.1 OUTPUT STAGE BALANCE (R108 and R113)

1. With TIME/DIV set to 2 ms display a 1 kHz signal (sinewave or squarewave) on Channel 1.
2. Adjust the horizontal POSITION control to the point where the lefthand end of the trace does not move when the X5 switch is operated.
3. Without re-adjusting the POSITION control, bring

the left-hand end of the trace to the centre vertical graticule line by adjustment of R113.

4. Position the trace centrally on the screen with the horizontal POSITION control.
5. Adjust R108 for the best horizontal linearity at the right and left-hand extremities of the CRT screen.

4.3.5.2 PRE-AMPLIFIER BALANCE (R37, R49 AND R80)

1. Set TIME/DIV to 2 ms.
2. Short tag C2 or the top lead of C20 to ground.
3. Set EXT-CH1-CH2 switch to EXT.
4. Connect test meter between test point (H-) and Chassis (+).
5. Adjust R49 so that the test meter reading is independent of the position of the \pm switch.
6. Disconnect the test meter.
7. Set TIME/DIV to 1 ms.
8. Adjust the left-hand end of the trace to the left-hand edge of the graticule by means of the POSITION control.
9. Turn TIME/DIV to CH2 and bring the spot to the centre vertical graticule line by adjusting R80.
10. Set TIME/DIV to EXT X.
11. Bring the spot to the central graticule line by adjusting R37.

4.3.5.3 CHANNEL 2 HORIZONTAL GAIN (R104)

1. Set TIME/DIV to CH2.
2. Set the output of the Amplitude Calibrator to 50 mV and connect to the input of Channel 2.
3. Set Channel 1 input switch to GND and channel 2 input switch to A.C.
4. Set Channel 2 VOLTS/DIV to 0.01.
5. Set horizontal deflection to exactly 5 division with R104.
6. Disconnect Calibrator.

4.3.6 TRIGGER AND SWEEP

4.3.6.1 TRIGGER SENSITIVITY (R31)

1. Set CH1 and CH2 VOLTS/DIV to 1 V and both channels on.
2. Feed 0.5 V 50 Hz squarewave to both INPUTS.
3. Set both AC-DC-GND switches to DC.
4. Set TIME/DIV to 2 ms.
5. Push TRIG LEVEL in with TRIG switches set to CH1 and +.
6. Adjust LEVEL for a triggered trace.
7. Turn R31 anti-clockwise until multi-triggering takes place. Note setting of R31.
8. Remove the 50 Hz input signal.
9. Feed 0.25 V 10 kHz signal to both INPUTS.
10. Set TIME/DIV to 100 μ s.
11. Turn R31 clockwise adjusting the LEVEL control if necessary to maintain triggering until a position is reached at which triggering can not be obtained or, the pot is fully clockwise. Note setting of R31.
12. Adjust R31 to halfway between the two positions previously noted.

13. Remove the 10 kHz input signal.
14. Feed a 1 div amplitude 10 MHz sinewave to CH1 and check that a locked trace can be obtained by adjustment of the LEVEL control on both +ve and -ve. If not turn R31 anti-clockwise sufficient to obtain a locked trace but not as far as in 7 above.
15. Repeat 14 on CH2 both +ve and -ve.

4.3.6.2 SWEEP STABILITY (R74)

1. Remove CAL signal.
2. Apply a 1 kHz signal.
3. Set TIME/DIV to 1 ms.
4. Bring the RH end of the trace on to the screen using the X POSITION control.
5. Adjust R74 anti-clockwise until the trace disappears noting the position of the end of the trace at that instant.
6. Turn R74 clockwise until the timebase starts to free run again noting the position of the end of the trace.
7. Re-adjust R74 to bring the RH end of the trace half way between the two positions previously noted.

4.3.6.3 1ms/DIV SWEEP ACCURACY (R89)

This adjustment should not be performed until any necessary adjustments have been made to R104. See para. 4.3.5.3.

1. Set TIME/DIV to 1 ms.
2. Display 1 ms markers from the Time Marker Generator on Channel 1.
3. Adjust R89 so that markers are exactly one major division apart over the centre 8 divisions. Leave Time Marker Generator connected.

4.3.6.4 SWEEP LENGTH (R77)

Adjust sweep length to 10.5 divisions with R77. Leave Time Marker Generator connected.

4.3.6.5 0.5 μ s/DIV SWEEP ACCURACY (C2)

1. Set Time Marker Generator to 0.5 μ s.
2. Set TIME/DIV to 0.5 μ s.
3. Adjust C2 (mounted on TIME/DIV switch) so that one marker occurs for each major division over the centre 8 divisions. (Alternatively, set Time Marker Generator to 1 μ s and adjust for one marker every 2 divisions).
4. Disconnect Time Marker Generator.

4.3.7. INTERNAL CALIBRATOR (R405)

1. Set Channel 1 input switch to DC.
2. Set VOLTS/DIV switch to 0.1 V.
3. Display a 0.5 V 1 kHz signal from the Amplitude Calibrator and adjust R613 for exactly 5 divisions vertical deflection.
4. Remove Amplitude Calibrator signal and connect the internal calibrator signal to Channel 1.
5. Adjust the amplitude of the displayed signal to exactly 5 divisions with R405.

For Service Manuals Contact
MAURITRON TECHNICAL SERVICES
8 Cherry Tree Rd, Chinnor
Oxon OX9 4QY
Tel:- 01844-351694 Fax:- 01844-352554
Email:- enquiries@mauritron.co.uk

SECTION 5

COMPONENT LIST

For Service Manuals Contact
MAURITRON TECHNICAL SERVICES
 8 Cherry Tree Rd, Chinnor
 Oxon OX9 4QY
Tel: 01844-351694 Fax: 01844-352554
Email: enquiries@mauritron.co.uk

Values of resistors are stated in ohms or multiples of ohms; ratings at 70°C are in watts or sub-multiples of watts. Values of capacitors are stated in sub-multiples of farads; ratings at 70°C are in volts or kilovolts.

Whenever possible, exact replacements for components should be used, although locally available alternatives may be satisfactory for standard components.

Any order for replacement parts should include:

- | | |
|--------------------------------|--------------------------|
| 1. Instrument type | 4. Component part number |
| 2. Instrument serial number | 5. Component value |
| 3. Component circuit reference | |

CIRCUIT REFERENCE BLOCKS

The table below gives the blocks of circuit references, so that the reader can relate the items listed in this chapter and their location in the circuitry and printed circuit boards in Section 6.

Circuit Reference		Circuit	Fig.
From	To		
1	300))	Trig Input & Horizontal Amplifier Sweep Generator Time/Div Switch	3 4 2, 3 4 and 6
301 401	400) 600)	CRT) Power Supply)	5
))))	Volts/Div Switch and Vertical Input Amplifier CH1 Volts/Div Switch and Vertical Input Amplifier CH2	1 A 1 B
601	1000))))	Y Amplifier Volts/Div Switches	2 1A, 1B and 6

ABBREVIATIONS

BM Button mica	CMP Cermet preset	PS Polystyrene
C Carbon	E Electrolytic	Se Selenium
CP Carbon preset	Ge Germanium	Si Silicon
CV Carbon variable	MF Metal Film	SM Silver mica
CER Ceramic	MO Metal oxide	WW Wire-wound
CT Ceramic Trimmer	PE Polyester	WWP Wire-wound preset
CM Cermet thick film	PP Polypropylene	WWW Wire-wound variable

TEKTRONIX U.K. LIMITED

36 - 38 Coldharbour Lane, Harpenden, Hertfordshire, England

Telephone: Harpenden 63141

Telex: 25559.

All requests for repairs or replacement parts should be directed to the Tektronix Field Office or representative in your area. This procedure will assure you the fastest possible service. In the UK enquiries should be made to Harpenden.

CIR REF	PART NUMBER	VALUE F	DESCRIPTION		
			TYPE	TOL %	RATING V
C1	285-0866-00	10 p	PS	1 p	350
C2	281-0137-00	6-30 p	CT		350
C3	285-0943-00	1.0 μ	PC	1	63
C4	285-0942-00	10 n	PS		125
C5	285-1057-00	50 p	PS	1 p	350
C6	285-0791-00	470 n	PE	10	125
C7	285-0792-00	4.7 n	PE	20	125
C20	281-0696-00	0.75 p	CER	0.1 p	500
C21	285-0773-00	100 n	PE	20	400
(1719) C23	290-0780-00	10 μ	E		25
(1719) C24	281-0802-00	6.8 p	CER	0.25 p	400
(1719) C29	285-0869-00	47 p	PS	2 p	350
(1719) C30	281-0710-00	10 n	CER		250
C31	285-0990-00	1.0 μ	PE		160
C32	285-0854-00	100 p	PS	2 p	350
(1719) C37	285-0982-00	82 p	PS	1 p	350
C38	290-0664-00	4.7 μ	E		160
(1703) C39	285-0776-00	27 p	PS	1 p	350
(1703) C41	285-0779-00	470 n	PE	20	100
C43	290-0625-00	4.7 μ	E		160
C44	285-0887-00	1.5 n	PS	5	125
(1703) C45	281-0676-00	2.2 p	CER	0.1 p	500
C46	281-0710-00	10 n	CER		250
C48	285-0866-00	10 p	PS	1 p	350
C49	281-0710-00	10 n	CER		250
C50	281-0710-00	10 n	CER		250
C51	281-0710-00	10 n	CER		250
C52	281-0734-00	100 n	CER		30
C53	281-0710-00	10 n	CER		250
C54	285-0867-00	20 p	PS	1 p	350
C55	285-0869-00	47 p	PS	2 p	350
C56	290-0664-00	4.7 μ	E		160
C57	281-0710-00	10 n	CER		250
C58	290-0669-00	330 μ	E		16
C59	285-0915-00	100 n	PE	20	100
(1670) C61	281-0710-00	10 n	CER		250
C62	285-0915-00	100 n	PE	20	100
C63	285-1054-00	270 p	PS	1	350
C64	285-0869-00	47 p	PS	2 p	350
C65	281-0731-00	5.6 p	CER	0.5 p	750
C301	281-0677-00	10 n	CER		2 k
C302	281-0710-00	10 n	CER		250
C303	281-0710-00	10 n	CER		250
C304	285-0788-00	100 n	PE	10	125
C401	281-0706-00	30 n	CER		1.5 k
C402	290-0659-00	2.2/2.2 m	E		16
C403	290-0673-00	330 μ	E		160
C404	281-0681-00	10 n	CER		4 k
C405	285-0874-00	470 p	PS	5	125
C406	290-0660-00	100 μ	E		100
C407	281-0681-00	10 n	CER		4 kV
C408	290-0673-00	330 μ	E		160

CIR REF	PART NUMBER	VALUE F	DESCRIPTION		
			TYPE	TOL %	RATING V
C409	290-0540-00	15 μ	E		450
C411	290-0540-00	15 μ	E		450
C412	290-0540-00	15 μ	E		450
C601	285-1058-00	10 n	PE	20	400
C602	285-0850-00	1 n	PS	5	125
C603	285-0847-00	560 p	PS	5	125
C630	285-0810-00	820 p	PS	5	125
C631	285-0854-00	100 p	PS	2 p	350
C632	285-1063-00	390 p	PS	5	160
C633	285-1015-00	4.7 n	PE	20	160
C634	285-1063-00	390 p	PS	5	160
C635	285-0872-00	180 p	PS	2	350
C636	281-0710-00	10 n	CER		250
C637	285-0854-00	100 p	PS	2 p	350
C638	281-0678-00	3 p	CER	0.1 p	500
C639	285-0810-00	820 p	PS	5	125
C640	285-0760-00	330 p	PS	5	125
C641	281-0157-00	5.5-65.5p	PP		500
C642	285-0872-00	100 p	PS	2	350
C643	285-0915-00	100 n	PE	20	100
C644	281-0678-00	3 p	CER	0.1 p	500
C645	290-0579-00	1 m	E		16
C646	290-0663-00	470 μ	E		10
C647	290-0627-00	22 μ	E		40
C648	290-0663-00	470 μ	E		10
C649	285-0760-00	330 p	PS	5	125
C652	285-0872-01	180 p	PS	2	350
C653	281-0710-00	10 n	CER		250
C654	281-0710-00	10 n	CER		250
C701	285-1058-00	10 n	PE	20	400
C702	285-0850-00	1 n	PS	5	125
C703	285-0847-00	560 p	PS	5	125
C704	281-0710-00	10 n	CER		250
*C901	285-0772-00	100 n	PE	10	400
C902	281-0137-00	6-30 p	CT		350
C903	281-0137-00	6-30 p	CT		350
C904	281-0137-00	6-30p	CT		350
C905	281-0137-00	6-30p	CT		350
C906	285-0854-00	100 p	PS	2	350
C907	285-0850-00	1 n	PS	5	125

CIR REF	PART NUMBER	VALUE	DESCRIPTION	TYPE	TOL %	RATING
D24	152-0062-01	75 V	1N914	Si		50 mA
D25	152-0062-01	75 V	1N914	Si		50 mA
D26	152-0062-01	75 V	1N914	Si		50 mA
D27	152-0062-01	75 V	1N914	Si		50 mA
D28	152-0062-01	75 V	1N914	Si		50 mA
D29	152-0062-01	75 V	1N914	Si		50 mA
D30	152-0062-01	75 V	1N914	Si		50 mA
D31	152-0062-01	75 V	1N914	Si		50 mA
D32	152-0062-01	75 V	1N914	Si		50 mA
D33	152-0062-01	75 V	1N914	Si		50 mA
D34	152-0062-01	75 V	1N914	Si		50 mA
D35	152-0062-01	75 V	1N914	Si		50 mA
D36	152-0062-01	75 V	1N914	Si		50 mA
D37	152-0062-01	75 V	1N914	Si		50 mA
D38	152-0062-01	75 V	1N914	Si		50 mA
D39	152-0062-01	75 V	1N914	Si		50 mA
D40	152-0062-01	75 V	1N914	Si		50 mA
D41	152-0062-01	75 V	1N914	Si		50 mA
D42	152-0062-01	75 V	1N914	Si		50 mA
D43	152-0062-01	75 V	1N914	Si		50 mA
D44	152-0062-01	75 V	1N914	Si		50 mA
D45	152-0062-02	75 V	1N4148T	Si		50 mA
D46	152-0062-01	75 V	1N914	Si		50 mA
D47	152-0062-01	75 V	1N914	Si		50 mA
D48	152-0062-01	75 V	1N914	Si		50 mA
D49	152-0062-01	75 V	1N914	Si		50 mA
D50	152-0062-01	75 V	1N4148	Si		50 mA
D51	152-0062-01	75 V	1N914	Si		50 mA (1659)
D52	152-0062-01	75 V	1N914	Si		50 mA
D53	152-0062-01	75 V	1N914	Si		50 mA
D54	152-0062-01	75 V	1N914	Si		50 mA
D55	152-0062-01	75 V	1N914	Si		50 mA
D57	152-0062-01	75 V	1N914	Si		50 mA
D58	152-0062-01	75 V	1N914	Si		50 mA
D59	152-0062-01	75 V	1N914	Si		50 mA
D61	152-0062-01	75 V	1N914	Si		50 mA
D62	152-0062-01	75 V	1N914	Si		50 mA
<p>For Service Manuals Contact MAURITRON TECHNICAL SERVICES 8 Cherry Tree Rd, Chinnor Oxon OX9 4QY Tel: 01844-351694 Fax: 01844-352554 Email: enquiries@mauritron.co.uk</p>						
D301	152-0610-00	82 V	Zener	Si	5	770 mW
D401	152-0566-00	200 V	SD2	Si		1 A
D402	152-0566-00	200 V	SD2	Si		1 A
D403	152-0566-00	200 V	SD2	Si		1 A
D404	152-0566-00	200 V	SD2	Si		1 A
D405	152-0339-00	50 V	1N4001	Si		500 mA
D406	152-0339-00	50 V	1N4001	Si		500 mA
D407	152-0567-00	3 kV	SCM30	Si		
D408	152-0567-00	3 kV	SCM30	Si		
D409	152-0567-00	3 kV	SCM30	Si		
D411	152-0062-01	75 V	1N914	Si		50 mA
D412	152-0062-01	75 V	1N914	Si		50 mA
D413	152-0062-01	75 V	1N914	Si		50 mA
D601	152-0483-00	10 V	C1104	Si		50 mA
D602	152-0062-02	65 V	1N4148T	Si		50 mA
D603	152-0062-02	75 V	1N4148T	Si		50 mA

CIR REF	PART NUMBER	VALUE	DESCRIPTION	TYPE	TOL %	RATING
D631	152-0062-01	75 V	1N914	Si		50 mA
D632	152-0062-01	75 V	1N914	Si		50 mA
D633	152-0062-01	75 V	1N914	Si		50 mA
D634	152-0062-01	75 V	1N914	Si		50 mA
D635	152-0614-00	75 V	1N4448	Si		50 mA
D636	152-0614-00	75 V	1N4448	Si		50 mA
D637	152-0614-00	75 V	1N4448	Si		50 mA
D638	152-0614-00	75 V	1N4448	Si		50 mA
D639	152-0614-00	75 V	1N4448	Si		50 mA
D641	152-0614-00	75 V	1N4448	Si		50 mA
D642	152-0614-00	75 V	1N4448	Si		50 mA
D643	152-0614-00	75 V	1N4448	Si		50 mA
D644	152-0347-00	7.5 V	Zener	Si	5	330 mW
D645	152-0062-01	75 V	1N914	Si		50 mA
D646	152-0062-01	75 V	1N914	Si		50 mA
D701	152-0483-00	10 V	C1104	Si		50 mA
D702	152-0062-02	75 V	1N4148T	Si		50 mA
D703	152-0062-02	75 V	1N4148T	Si		50 mA

For Service Manuals Contact
MAURITRON TECHNICAL SERVICES
8 Cherry Tree Rd, Chinnor
Oxon OX9 4QY
Tel:- 01844-351694 Fax:- 01844-352554
Email:- enquiries@mauritron.co.uk

CIR REF	PART NUMBER	VALUE	DESCRIPTION
FB21	276-0597-00		Ferrite bead FX115
FB22	276-0597-00		Ferrite bead FX115
FB23	276-0597-00		Ferrite bead FX115
FS401 or	159-0077-00 159-0079-00	250 mA 500 mA	Fuse Delay 1.25" 200-240V Fuse Delay 1.25" 100-120V
L21	108-0483-00	16 µH	Fixed Inductor
L22	108-0780-00	53 µH	Fixed Inductor
L631	108-0482-00	160 µH	Fixed Inductor
L632	108-0482-00	160 µH	Fixed Inductor
CIR REF	PART NUMBER	VALUE	DESCRIPTION
		Ohms	TYPE TOL RATING
			% W
R1	325-0175-00	2.37M	MF 1 1
R2	325-0174-00	787 K	MF 1 500 m
R3	325-0173-00	392 k	MF 1 250 m
R4	325-0172-00	237 k	MF 1 250 m
R5	325-0171-00	78.7 k	MF 1 250 m
R6	325-0171-00	78.7 k	MF 1 250 m
R19	317-0334-01	330 k	C 5 125 m
R20	317-0154-01	150 k	C 5 125 m
R21	311-1734-00	47 k	CV 20 150 m

CIR REF	PART NUMBER	VALUE	DESCRIPTION	TOL %	RATING W
R22	317-0473-01	47 k	C	5	125 m
R23	317-0914-01	910 k	C	5	125 m
R24	317-0154-01	150 k	C	5	125 m
R25	317-0332-01	3.3 k	C	5	125 m
R26	317-0433-01	43 k	C	5	125 m (1670)
R27	317-0332-01	3.3 k	C	5	125 m
R28	317-0392-01	3.9 k	C	5	125 m
R29	317-0162-01	1.6 k	C	5	125 m
R30	317-0561-01	560 k	C	5	125 m
R31	311-1503-00	100	C	20	75 m
R32	317-0333-01	33 k	C	5	125 m (1719) (1719)
R34	317-0682-01	6.8 k	C	5	125 m
R35	317-0392-01	3.9 k	C	5	125 m
R36	317-0103-01	10 k	C	5	125 m
R37	311-1858-00	100 k	CP	20	75 m (1719)
R38	317-0330-01	33	C	5	125 m
R41	317-0561-01	560	C	5	125 m
R42	317-0680-01	68	C	5	125 m
R44	317-0682-01	6.8 k	C	5	125 m (1719)
R46	317-0221-00	220	C	5	125 m
R48	317-0183-01	18 k	C	5	125 m
R49	311-1512-00	22 k	CP	20	75 m
R51	317-0103-01	10 k	C	5	125 m
R52	317-0512-01	5.1 k	C	5	125 m

CIR REF	PART NUMBER	VALUE Ohms	DESCRIPTION		
			TYPE	TOL %	RATING W
R53	317-0682-01	6.8 k	C	5	125 m
R54	317-0393-01	39 k	C	5	125 m
R55	317-0682-01	6.8 k	C	5	125 m
R56	317-0183-01	18 k	C	5	125 m
R57	317-0822-01	8.2 k	C	5	125 m
R58	317-0273-01	27 k	C	5	125 m
R59	317-0512-01	5.1 k	C	5	125 m
R60	317-0100-01	10	C	5	125 m
R61	317-0332-01	3.3 k	C	5	125 m
R62	317-0243-01	24 k	C	5	125 m
R63	317-0104-01	100 k	C	5	125 m
R64	317-0222-01	2.2 k	C	5	125 m
R65	317-0123-01	12 k	C	5	125 m
R66	317-0183-01	18 k	C	5	125 m
R67	303-0113-01	11 k	C	5	1
R68	321-0306-48	15 k	MF	1	125 m
R69	311-1525-00	22 k	CV	20	250 m
R70	317-0470-01	47	C	5	125 m
R72	317-0302-01	3 k	C	5	125 m
R73	317-0203-01	20 k	C	5	125 m
R74	311-1510-00	10 k	CP	20	75 m
R75	317-0123-01	12 k	C	5	125 m
R76	317-0222-01	2.2 k	C	5	125 m
R77	311-1510-00	10 k	CP	20	75 m
R78	317-0103-01	10 k	C	5	125 m
R79	315-0393-02	39 k	C	5	250 m
R80	311-1511-00	15 k	CP	20	75 m
R81	317-0102-01	1 k	C	5	125 m
R82	321-1257-48	4.7 k	MF	1	125 m
R83	317-0183-01	18 k	C	5	125 m
R84	317-0153-01	15 k	C	5	125 m
R85	317-0332-01	3.3 k	C	5	125 m
R86	317-0103-01	10 k	C	5	125 m
R87	317-0334-01	330 k	C	5	125 m
R88	317-0512-01	5.1 k	C	5	125 m
R89	311-1512-00	22 k	CP	20	75 m
R90	317-0151-01	150	C	5	125 m
R91	317-0432-01	4.3 k	C	5	125 m
R92	307-0143-00	5.6 k	MO	5	1.5
R93	315-0122-02	1.2 k	C	5	250 m
R94	317-0431-01	430	C	5	125 m
R95	317-0274-01	270 k	C	5	125 m
R96	317-0224-01	220 k	C	5	125 m
R97	317-0822-01	8.2 k	C	5	125 m
R98	317-0101-01	100	C	5	125 m
R99	317-0203-01	20 k	C	5	125 m
R101	317-0471-01	470	C	5	125 m
R102	317-0564-01	560 k	C	5	125 m
R104	311-1505-00	220	CP	20	75 m
R105	301-0203-01	20 k	C	5	500 m
R107	315-0122-02	1.2 k	C	5	250 m
R108	311-1507-00	1 k	CP	20	75 m
R109	307-0143-00	5.6 k	MO	5	1.5
R111	301-0223-01	22 k	C	5	500 m
R112	317-0561-01	560	C	5	125 m
R113	311-1532-00	330	CP	20	75 m
R114	317-0473-01	47 k	C	5	125 m
R115	317-0103-01	10 k	C	5	125 m
R116	317-0223-01	22 k	C	5	125 m
R117	317-0391-01	390	C	5	125 m
R118	317-0123-01	12 k	C	5	125 m
R119	317-0100-01	10	C	5	125 m
R120	317-0183-01	18 k	C	5	125 m
R121	317-0434-01	430 k	C	5	125 m
R122	317-0564-01	560 k	C	5	125 m
R123	317-0303-01	30 k	C	5	125 m
R124	317-0562-01	5.6 k	C	5	125 m
R125	317-0100-01	10	C	5	125 m
R126	317-0100-01	10	C	5	125 m
R127	317-0203-01	20 k	C	5	125 m
R128	316-0335-02	3.3 M	C	10	250 m
R129	317-0104-01	100 k	C	5	125 m
R130	317-0154-01	150 k	C	5	125 m

CIR REF	PART NUMBER	VALUE Ohms	DESCRIPTION		
			TYPE	TOL %	RATING W
R131	317-0822-01	8.2 k	C	5	125 m
R132	317-0123-01	12 k	C	5	125 m
R133	317-0684-01	680 k	C	5	125 m
R134	317-0822-01	8.2 k	C	5	125 m
R135	317-0332-01	3.3 k	C	5	125 m
R136	317-0333-01	33 k	C	5	125 m
R137	317-0393-01	39 k	C	5	125 m
R138	317-0823-01	82 k	C	5	125 m
R139	317-0104-01	100 k	C	5	125 m
R301	311-1020-00	1 M	CV	20	250 m
R302	316-0155-01	1.5 M	C	10	250 m
R303	311-1516-00	1 M	CV	20	250 m
R304	317-0394-01	390 k	C	5	125 m
R305	311-1514-00	220 k	CP	20	75 m
R306	317-0105-01	1 M	C	5	125 m
R307	311-1514-00	220 k	CP	20	75 m
R308	316-0106-01	10 M	C	10	250 m
R309	315-0222-01	2.2 k	C	5	250 m
R400	317-0273-01	27 k	C	5	125 m (169)
R401	316-0273-01	27 k	C	10	250 m
R402	317-0103-01	10 k	C	5	125 m
R403	317-0220-01	22	C	5	125 m
R404	321-1325-48	24 k	MF	1	125 m
R405	311-1510-00	10 k	CP	20	75 m
R406	301-0201-01	200	C	5	500 m
R407	308-0753-00	620	WW	5	3
R408	317-0222-01	2.2 k	C	5	125 m
R601	321-0481-48	1 M	MF	1	125 m
R602	317-0104-01	100 k	C	5	125 m
R603	317-0101-01	100	C	5	125 m
R604	311-1504-00	150	CP	20	75 m
R605	317-0132-01	1.3 k	C	5	125 m
R608	311-1510-00	10 k	CP	20	75 m
R611	317-0562-00	5.6 k	C	5	125 m
R612	317-0432-01	4.3 k	C	5	125 m
R613	311-1509-00	4.7 k	CP	20	75 m
R614	317-0123-01	12 k	C	5	125 m
R615	317-0223-01	22 k	C	5	125 m
R616	317-0223-01	22 k	C	5	125 m
R617	317-0181-01	180	C	5	125 m
R618	311-1512-00	22 k	CP	20	75 m
R619	311-1526-00	22 k	CV	20	250 m
R621	317-0223-01	22 k	C	5	125 m
R631	317-0184-01	180 k	C	5	125 m
R632	317-0103-01	10 k	C	5	125 m
R633	317-0223-01	22 k	C	5	125 m
R634	317-0203-01	20 k	C	5	125 m
R635	317-0331-01	330	C	5	125 m
R636	315-0103-01	10 k	C	5	250 m
R637	317-0122-01	1.2 k	C	5	125 m
R638	317-0123-01	12 k	C	5	125 m
R639	317-0203-01	20 k	C	5	125 m
R640	317-0681-01	680	C	5	125 m
R641	317-0331-01	330	C	5	125 m

CIR REF	PART NUMBER	VALUE Ohms	DESCRIPTION		
			TYPE	TOL %	RATING W
R642	317-0184-01	180 k	C	5	125 m
R643	317-0103-01	10 k	C	5	125 m
R644	317-0223-01	22 k	C	5	125 m
R645	317-0302-01	3 k	C	5	125 m
R647	315-0103-01	10 k	C	5	250 m
R648	317-0682-01	6.8 k	C	5	125 m
R649	307-0407-00	1.3 k	MO	5	1.5
R651	315-0911-01	910	C	5	250 m
R652	317-0560-01	56	C	5	125 m
R653	311-1507-00	1 k	CP	20	75 m
R654	317-0330-01	33	C	5	125 m
R655	307-0407-00	1.3 k	MO	5	1.5
R656	315-0911-01	910	C	5	250 m
R657	317-0682-01	6.8 k	C	5	125 m
R658	317-0683-01	68 k	C	5	125 m
R659	315-0181-01	180	C	5	250 m
R661	315-0103-01	10 k	C	5	250 m
R663	317-0162-01	1.6 k	C	5	125 m
R664	317-0302-01	3 k	C	5	125 m
R665	317-0271-01	270	C	5	125 m
R666	317-0752-01	7.5 k	C	5	125 m
R667	317-0682-01	6.8 k	C	5	125 m
R668	311-1508-00	2.2 k	CP	20	75 m
R669	317-0681-01	680	C	5	125 m
R671	311-1532-00	330	CP	20	75 m
R672	317-0274-01	270 k	C	5	125 m
R673	317-0123-01	12 k	C	5	125 m
R674	317-0274-01	270 k	C	5	125 m
R701	321-0481-48	1 M	MF	1	125 m
R702	317-0104-01	100 k	C	5	125 m
R703	317-0101-01	100	C	5	125 m
R704	311-1504-00	150	CP	20	75 m
R705	317-0132-01	1.3 k	C	5	125 m
R708	311-1510-00	10 k	CP	20	75 m
R711	317-0562-01	5.6 k	C	5	125 m
R712	317-0432-01	4.3 k	C	5	125 m
R713	311-1509-00	4.7 k	CP	20	75 m
R714	317-0123-01	12 k	C	5	125 m
R715	317-0223-01	22 k	C	5	125 m
R716	317-0223-01	22 k	C	5	125 m
R717	317-0181-01	180	C	5	125 m
R718	311-1512-00	22 k	CP	20	75 m
R719	311-1526-00	22 k	CV	20	250 m
R721	317-0223-01	22 k	C	5	125 m
R722	317-0223-01	22 k	C	5	125 m
*R900	317-0180-01	18	C	5	125 m
*R901	321-0989-48	990 k	MF	1	125 m
*R902	321-0988-48	900 k	MF	1	125 m
*R903	321-1389-48	111 k	MF	1	125 m
*R904	321-1289-48	10.1 k	MF	1	125 m
*R905	325-0141-00	162	MF	1	250 m
*R906	321-0843-48	270	MF	1	125 m
*R907	321-0101-48	110	MF	1	125 m
*R908	317-0750-01	75	C	5	125 m
*R909	317-0622-01	6.2 k	C	5	125 m
*R911	307-0382-00	7.5	C	5	125 m

CIR REF	PART NUMBER	VALUE Ohms	DESCRIPTION		
			TYPE	TOL %	RATING W
S1	260-1535-00				Rotary Time/Div
S20	260-1307-01				Slide EXT-CH1-CH2
S21	260-1307-01				Slide + -
S22	260-1307-01				Slide AC - TV
S23	with R69				Push-Pull X1 - X5
S24	with R21				Push-Pull AUTO
S401	with R301				Power On/Off
S631	with R719				Rotary CH2 - Off
S632	with R619				Rotary CH1 - Off
*S901	260-1307-01				Slide AC GND DC
*S902	260-1534-01				Rotary Volts/Div
SK21	131-1654-00				Socket Ext X TRIG
SK22	136-0542-00				Socket Probe Test
SK301	136-0542-00				Socket Z Mod
SK401	136-0541-02				Volt Selector
SK402	131-0542-00				CAL 0.5 V PP
*SK901	131-1654-00				Socket Input
*SK902	136-0542-00				Socket Gnd.
T401	120-1018-00				Transformer (Power)
TH20	307-1081-00	4.7 k			VA1109 500 m (1631)
TH21	307-0408-00	50 Ω			VA1034 20 500 m
TH631	307-0408-00	50 Ω			VA2034 20 500 m

*Two per instrument (CH1 and CH2)

CIR REF	PART NUMBER	DESCRIPTION		TYPE
TR21	151-0127-02	BSX20	Si	NPN
TR22	151-0320-00	MPS6518	Si	PNP
TR23	151-0317-01	BC109C	Si	NPN
TR24	151-0320-00	MPS6518	Si	PNP
TR25	151-0326-01	BC107	Si	NPN
TR26	151-0320-00	MPS6518	Si	PNP
TR27	151-0326-01	BC107	Si	NPN
TR28	151-0525-00	FRB749	Si	NPN
TR29	151-0326-01	BC107	Si	NPN
TR30	151-0326-01	BC107	Si	NPN
TR31	151-0242-00	2N3904	Si	NPN
TR32	151-0326-01	BC107	Si	NPN
(1631) TR33	151-0257-03	FRB749	Si	NPN
TR34	151-0320-00	MPS6518	Si	PNP
TR35	151-0326-01	BC107	Si	NPN
TR36	151-1076-01	F.E.T. TEL. SPEC	Si	N.Channel
TR37	151-0525-00	FRB749	Si	PNP
TR38	151-0320-01	MPS6518	Si	NPN
TR39	151-0317-01	BC109C	Si	NPN
TR601	151-1076-00	F.E.T. TEL. SPEC.	Si	N.Channel
TR602	151-0326-01	BC107	Si	NPN
TR603	151-0317-01	BC109C	Si	NPN
TR604	151-0326-01	BC107	Si	NPN
TR631	151-0320-00	MPS6518	Si	PNP
TR632	151-0320-00	MPS6518	Si	PNP
TR633	151-0127-02	BSX20	Si	NPN
TR634	151-0310-00	TEL. SPEC	Si	NPN
TR635	151-0310-00	TEL. SPEC	Si	NPN
TR636	151-0127-02	BSX20	Si	NPN
TR637	151-0401-00	BC263C	Si	PNP
TR701	151-1076-00	F.E.T. TEL. SPEC	Si	N.Channel
TR702	151-0326-01	BC107	Si	NPN
TR703	151-0317-01	BC109C	Si	NPN
TR704	151-0326-01	BC107	Si	NPN
V301	154-0693-00 or 154-0693-01	CRT G.E.C. Type 1324Y P31 CRT G.E.C. Type 1346Y P7		
V401	150-0178-00 <i>NLA MAR86</i>	Lamp Neon Power On		

For Service Manuals Contact
MAURITRON TECHNICAL SERVICES
8 Cherry Tree Rd, Chinnor
Oxon OX9 4QY
Tel:- 01844-351694 Fax:- 01844-352554
Email:- enquiries@mauritron.co.uk

MECHANICAL PARTS

For the positions of the Mechanical Parts see the exploded drawing opposite

DRAWING	PART NUMBER	DESCRIPTION	DRAWING	PART NUMBER	DESCRIPTION	
1	366-1636-00	Knob Assembly	58	348-0483-00	Foot	
2	366-1665-01	Knob Assembly	(376-0177-00	Coupling	
3	366-1657-02	Knob Assembly	(213-0248-00	Screw M3 x 3mm (2)	
4	366-0389-02	Knob Assembly	60	384-1142-19	Extension shaft	
			61	161-0059-01	Power Cable (UK)	
			62	161-0051-01	Power Cable (USA)	
7	333-2117-03	Front Panel (upper)				
8	333-2118-03	Front Panel (lower)	64	334-2752-00	Mod record label	
9	200-1926-01	Front Bezel (upper)	65	220-0727-00	Spire clip	
10	100-1927-01	Front Bezel (lower)	66	385-0196-00	Spacer 6 BA x 11/16"	
			67	129-0189-00	Post	
12	331-0407-01	Graticule (blue)	68	210-0297-01	Solder tag 4 BA	
or	331-0407-03	Graticule (amber for P7 tube)	69	252-0610-00	PVC insulation (8½")	
13	386-3482-01	CRT Front support	70	348-0489-00	Ring grommet	
14	343-0608-00	Spring clamp for CRT	71	348-0162-00	Grommet 3/8" ID	
15	344-0293-00	Spring clamp for CRT	72	348-0161-00	Grommet 5/32" ID	
16	386-3488-02	CRT support shield (rear)	1712			
17	252-0675-00	Foam brushed nylon	74	337-1834-00	Shield (electrical)	
18	385-0220-03	Spacer	75	381-0369-01	Bar - Transformer mounting	
19	200-1995-00	Guard	76	348-0488-00	Grommet 5/16" ID	
			77	343-0180-00	Cable cleat	
			78	210-0318-00	Solder Tag, 8 BA	
22	220-0783-01	Special nut	1712			
23	337-2280-02	CRT gun shield	79	210-0297-00	Solder Tag, 6 BA	
24	337-1835-00	CRT shield	80	213-0448-00	Screw 8 BA x CH HD x 1/4"	
25	348-0487-00	Ring grommet	81	213-0393-00	Screw 6 BA PAN HD x 1/4"	
26	258-0456-00	Copper strip (4")	82	213-0394-00	Screw 6 BA PAN HD x 5/16"	
27	252-0608-00	Foam Rubber (18")	83	213-0688-00	Screw 6 BA PAN HD x 1/4"	
28	253-0108-00	PVC Tape (100")				
29	348-0458-01	CRT buffer				
31	101-0029-02	Trim top	1732			
32	390-0533-01	Cabinet side (RH)	1732			
33	390-0535-01	Cabinet side (LH)	1732	89	213-0472-00	Screw 4 BA CSK HD x 3/4"
34	390-0509-01	Cabinet Rear		91	213-0593-00	Screw 4 BA HEX HD x 1/2"
35	334-2668-00	Rear label		92	213-0602-01	Screw 4 BA HEX HD x 3/4"
36	334-2968-00	Warning marker Ident.		93	213-0495-01	Screw 2 BA PAN HD x 1/4"
37	343-0609-00	Handle end		94	213-0540-01	Screw 2 BA PAN HD x 1/4"
38	343-0609-00	Bracket		95	213-0550-01	Screw 2 BA PAN HD x 2"
39	407-1768-00	Bracket (plain)		96	213-0602-01	Screw 4 BA HEX HD x 3/4"
				97	213-0356-00	Screw Self Tap No 2 CSK HD x 3/8"
41	367-0217-00	Handle		98	213-0388-00	Screw 4 BA PAN HD x 1/4"
42	381 0368-00	Bar, stiffener		99	213-0381-00	Screw Self Tap No 6 PAN HD x 3/8"
				100	213-0729-00	Screw Self Tap No 6 CSK HD x 3/4"
44	348-0504-00	Flip stand		101	210-1208-00	Washer 6 BA crinkle
				102	210-1210-00	Washer 6 BA shakeproof
46	101-0037-00	Trim Top Moulding	1732	103	210-1209-00	Washer 6 BA plain
47	101-0038-00	Trim Top R/H Moulding	1732	104	210-1223-00	Washer 6 BA spring
48	101-0039-00	Trim Top L/H Moulding	1732			
52	334-2669-01	Name plate (R hand)	1732	110	210-1222-00	Washer 4 BA spring
53	334-2670-01	Name plate (L hand)	1732			
54	200-2040-01	Cover, electrical		112	210-3051-00	Washer 3/8" ID plain
55	386-3489-00	Support strap		113	210-1165-00	Washer 3/8" ID shakeproof
56	342-0323-01	Insulator cover		114	210-1238-00	Washer 5/16" ID shakeproof
57	210-1247-00	Felt washer		115	220-0716-00	Nut 6 BA full.

For Service Manuals Contact
MAURITRON TECHNICAL SERVICES
8 Cherry Tree Rd, Chinnor
Oxon OX9 4QY
Tel: 01844-351694 Fax: 01844-352554
Email: enquiries@mauritron.co.uk

SECTION 6

CIRCUIT DIAGRAMS

To minimise the risk of misinterpretation of component values on circuit diagrams, the decimal point has been replaced by the multiplier or sub-multiplier of the basic unit. For instance, 2.2 megohms is shown as 2M2 and 1.8 picofarads is shown as 1p8.

To aid the reader further, in addition to the block Circuit Reference Table in Section 5.1, to locate a component in the circuit diagrams, a table is provided at the top, in which the circuit reference will appear, where practicable, directly above the component being sought.

FOR RELATED CIRCUITS SEE FIG'S 3 & 4

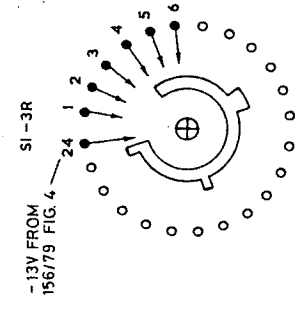
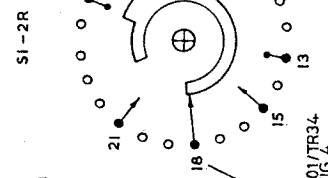
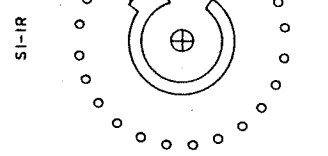
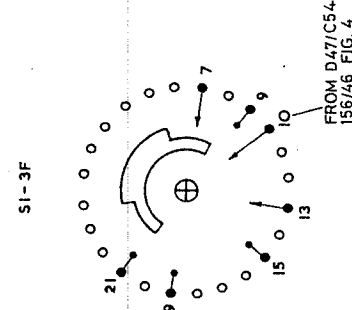
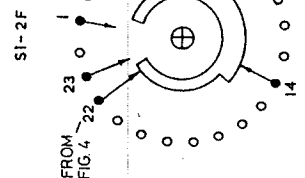
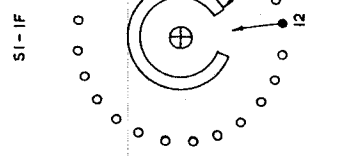

FOR RELATED CIRCUITS SEE FIG'S 1A & 1B

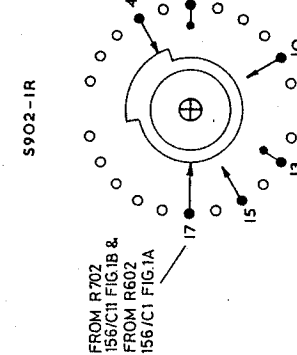
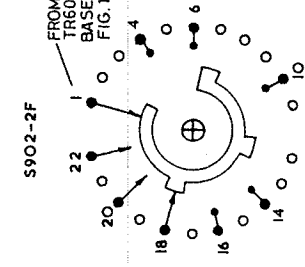
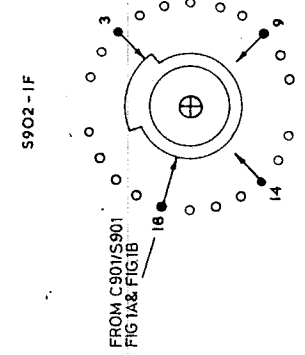

For Service Manuals Contact
MAURITRON TECHNICAL SERVICES
 8 Cherry Tree Rd, Chinnor
 Oxon OX9 4QY
 Tel:- 01844-351694 Fax:- 01844-352554
 Email:- enquiries@mauritron.co.uk

NOTES.
 1. SWITCH IS SHOWN IN FULLY ANTICLOCKWISE POSITION
 2. No.OF POSITIONS 21

NOTES.
 1. SWITCH IS SHOWN IN FULLY ANTICLOCKWISE POSITION
 2. No.OF POSITIONS 9

TIME/DIV. SWITCH D61A

VOLTS/DIV. SWITCH

FIG. 6

RESISTORS	901	902	903	904	911	701	702	703	704	905	711	712	713	714	715	716	717	718	719
CAPACITORS	901	902	903	904	905	701	702	703	704	906	702	703	704	705	907	908	909	910	911
MISC	901	902	903	904	905	701	702	703	704	906	702	703	704	705	907	908	909	910	911

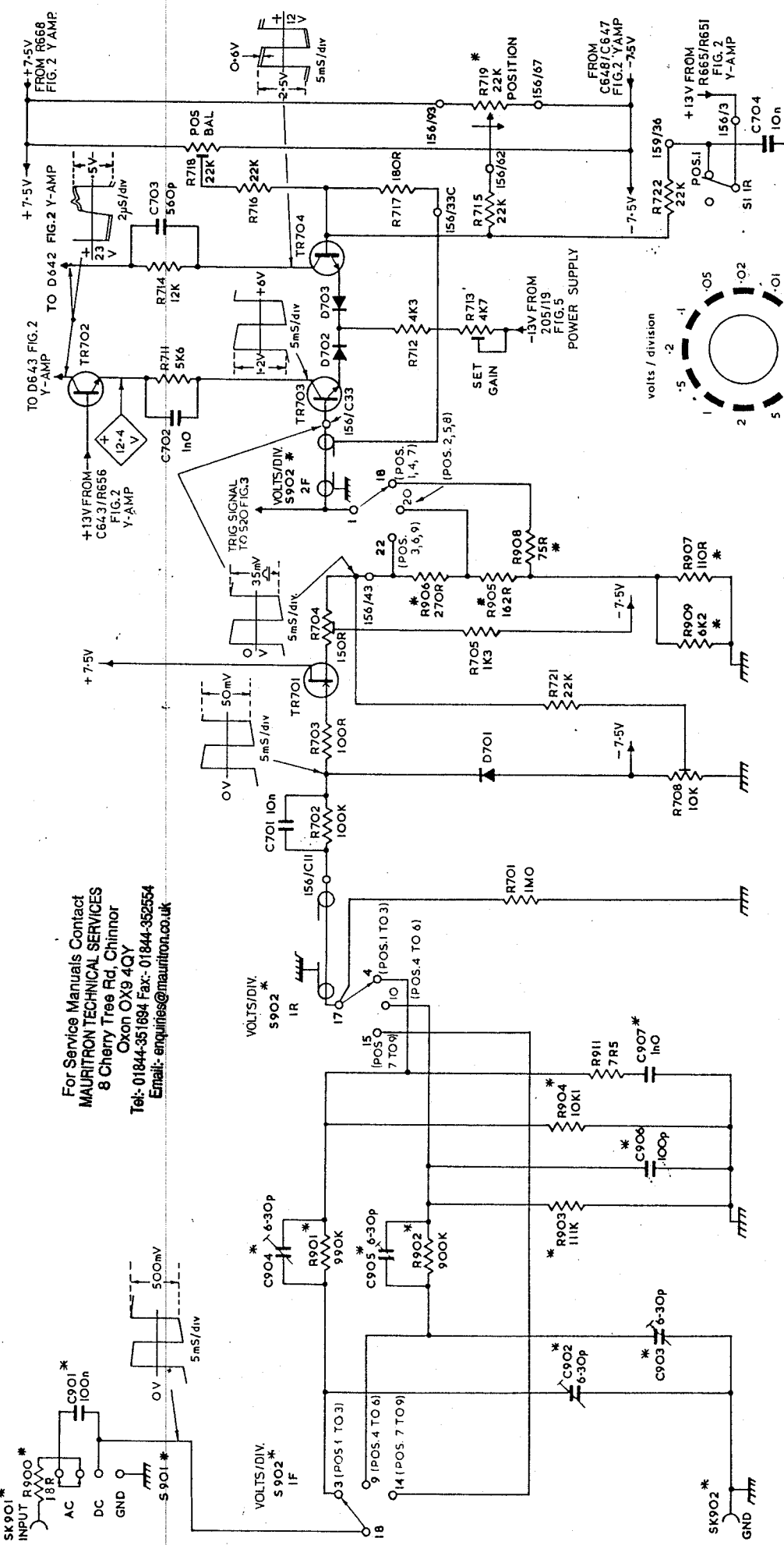

For Service Manuals Contact
MAURITRON TECHNICAL SERVICES
 8 Cherry Tree Rd, Chinnor
 Oxon OX9 4QY
 Tel: 01844-351894 Fax: 01844-352554
 Email: enquiries@maurtron.co.uk

- NOTES
1. 156/IC1 DENOTES PC BOARD/EYELET OR TERMINAL No. CONNECTION
 2. * DENOTES COMPONENTS NOT MOUNTED ON PC BOARD
 3. SWITCH IS SHOWN IN FULLY ANTICLOCKWISE POSITION.
 4. ALL WAVEFORMS MEASURED WITH CAL WAVEFORM FED TO BOTH CHANNELS VOLTS/DIV SET TO 0.1 TRIG SELECTOR TO CH.1 AND TIME / DIV. TO 2ms

VOLTS / DIV. SWITCH. & VERT. INPUT AMPLIFIER CH.2 D61A
 FIG.1B

FRONT PANEL MARKING

TEKTRONIX (UK) LIMITEDD61A(3)
A/L 1

INSTRUMENT TYPE D61A	ISSUE NO 3	AMENDMENT LIST 1	DATE 26-10-76
Description of Amendment			Effective from Serial Number
<p>(1) Page 4/1 Para 4.3.2 Lines 8 to 10. CHANGE to read -</p> <p>If the movement of the trace is greater than 1 div when the mains voltage is adjusted to $\pm 10\%$ of nominal, use the following procedure:-</p> <ol style="list-style-type: none"> 1. Set the Test Meter to a range suitable for measuring 10 V d.c. 2. Connect the negative test lead to test point 67 and the positive test lead to chassis. 3. Set CH1 & CH2 AC-DC-GND to GND. 4. Adjust R668 for a meter reading of 7.5 V approximately. 5. Re-check the trace movement for $\pm 10\%$ variation. 6. If the specification cannot be met, raise or lower the voltage setting which must remain within the limits of 7 V to 7.7 V. 7. If R668 is altered, the Vertical Amplifier Balance procedures in 4.3.4 must be re-checked. 			<p>For Service Manuals Contact MAURITRON TECHNICAL SERVICES 8 Cherry Tree Rd, Chinnor Oxon OX9 4QY Tel: 01844-351694 Fax: 01844-352554 Email: enquiries@mauritron.co.uk</p> <p>All Manuals</p>
<p>(2) Page 5/1 Abbreviation for Wire-wound variable should read WWV.</p>			All Manuals
<p>(3) Page 5/2</p> <p>C404 - CHANGE to read 281-0837-00, 20n 20% 5k) C407 - DELETE)</p> <p>C601 - CHANGE to read 285-1017-00) C902 - CHANGE to read 281-0745-00, 4p7, CER, 0.5% 400V) C903 - CHANGE to read 281-0154-00, 2-10p, PPT 400V) C904 - CHANGE to read 281-0154-00, 2-10p, PPT 400V) C905 - CHANGE to read 281-0156-00, 1p4-5p5, PPT 400V) C906 - CHANGE to read 285-0869-00, 47p) C907 - CHANGE to read 281-0157-00, 5p5-65p, PPT 400V) C908 - ADD 285-0870-00, 120p, PS, 2% 350V)</p>			<p>621251</p> <p>599101</p>

RESISTORS	611	612	613	614	616	615	618	711	712	713	714	715	716	717	718
CAPACITORS	602	603						702	703						
MISC	TR 602	TR 603	D 602	D 603	TR 604			TR 702	TR 703	D 702	D 703	TR 704	SI-1R		704

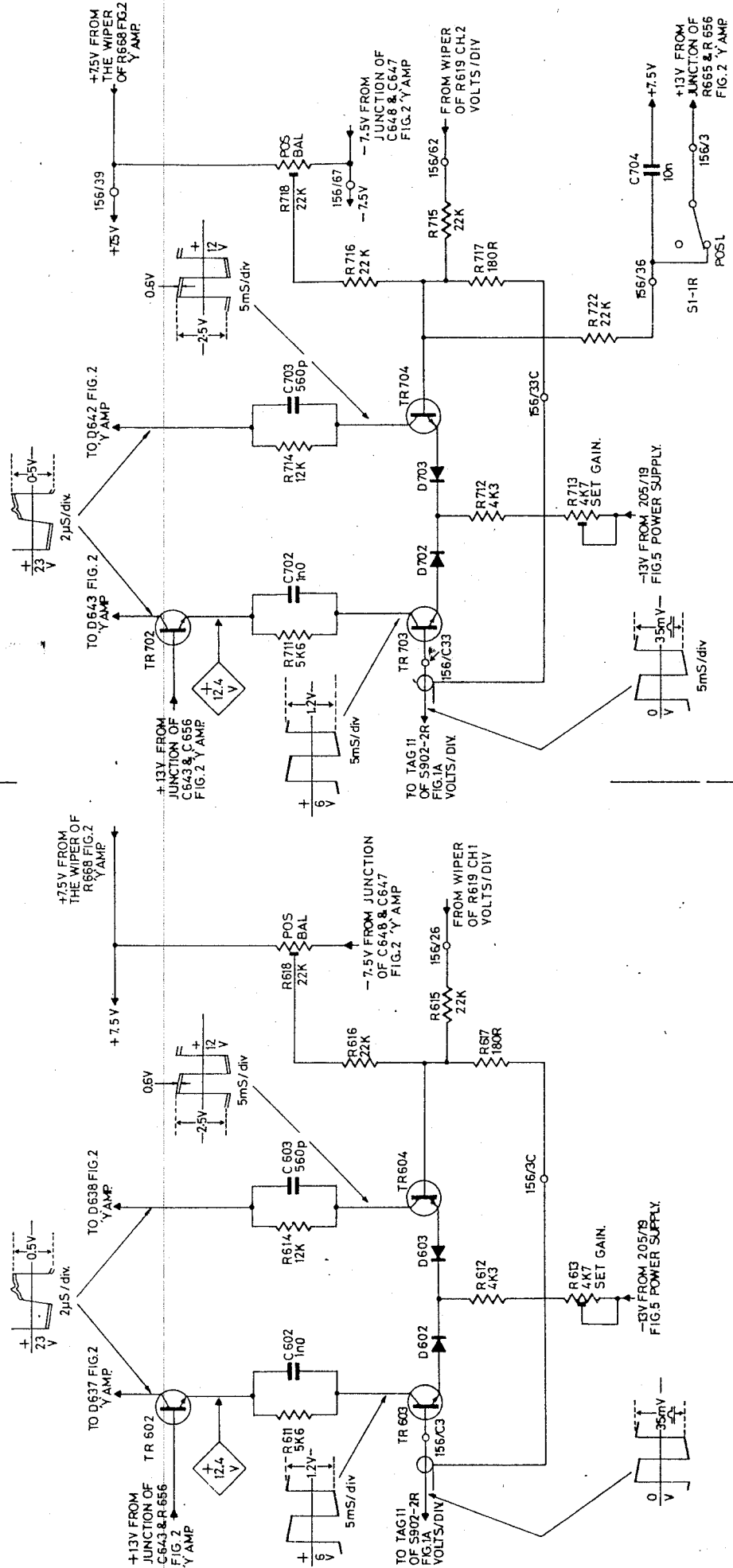

NOTES:
 1. * DENOTES COMPONENTS NOT MOUNTED ON P.C. BOARD.
 2. 156/26 DENOTES P.C. BOARD/EYELET OR TERMINAL NO. CONNECTION.
 3. ALL WAVEFORMS MEASURED WITH CAL WAVEFORM FED TO BOTH CHANNELS VOLTS/DIV SET TO Q1 TRIG SELECTOR TO CH1 AND TIME/DIV TO 2ms.

VERT INPUT AMPLIFIER CH.1 D61A
 FIG.1B P.C.156 MK2

VERT INPUT AMPLIFIER CH.2 D61A
 FIG.1B P.C.156 MK2

RESISTORS	900	901	902	903	904	905	906	907	908	601	602	603	604	605	621	606	607	608	609	610	619
CAPACITORS	901	902	903	904	905	906	907	908	909	910	911	912	913	914	915	916	917	918	919	920	921
MISC	901	902	903	904	905	906	907	908	909	910	911	912	913	914	915	916	917	918	919	920	921
SK 901-902	S 901	S 902	S 903	S 904	S 905	S 906	S 907	S 908	S 909	S 910	S 911	S 912	S 913	S 914	S 915	S 916	S 917	S 918	S 919	S 920	S 921

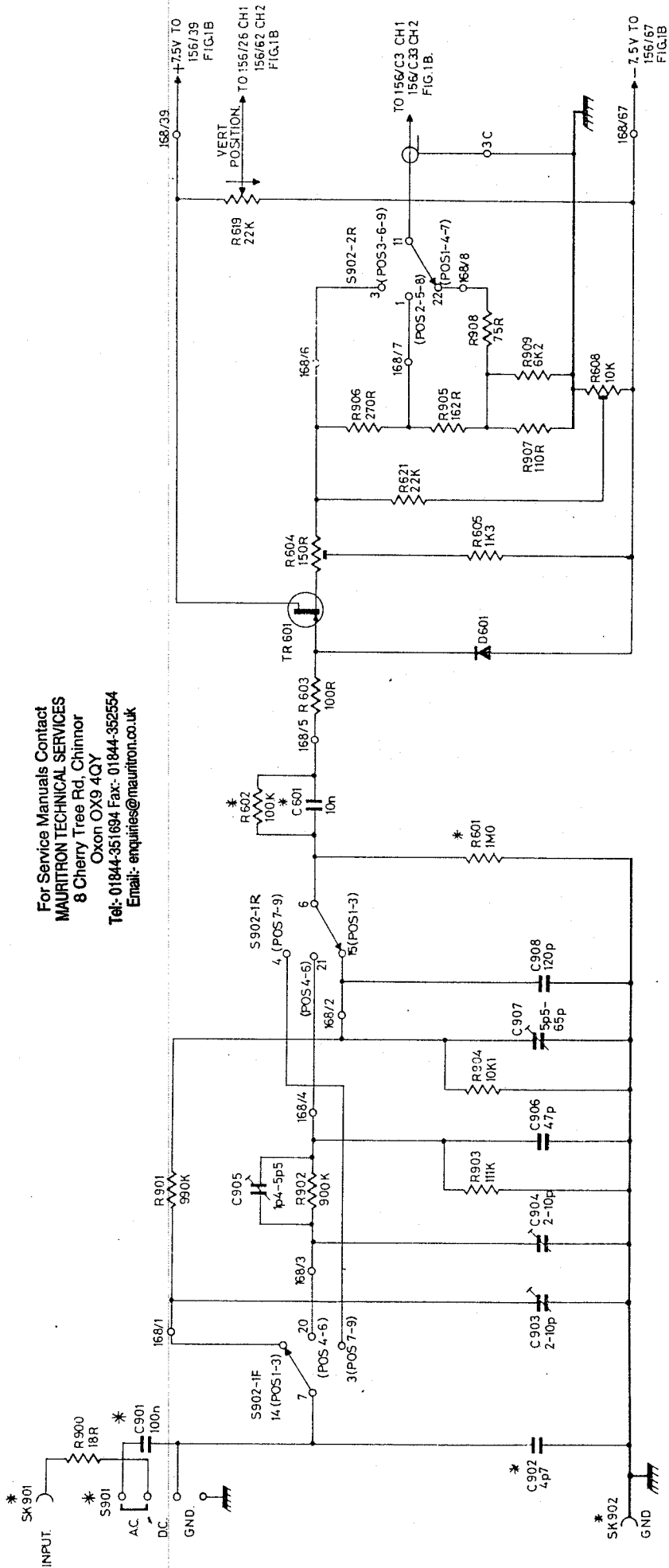

For Service Manuals Contact
MAURITRON TECHNICAL SERVICES
 8 Cherry Tree Rd, Chinnor
 Oxon OX9 4QY
 Tel: 01844-351694 Fax: 01844-352554
 Email: enquiries@mauritron.co.uk

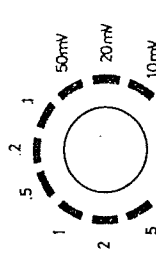

VOLTS / DIV SWITCH CH1 - CH2 INPUT STAGES P.C.168 D61A, FIG.1A. MK2

- NOTES.
1. 168/1 DENOTES P.C. BOARD/EYELET OR TERMINAL NO CONNECTION.
 2. * DENOTES COMPONENTS NOT MOUNTED ON P.C. BOARD.
 3. SWITCH IS SHOWN IN FULLY ANTICLOCKWISE POSITION.

FRONT PANEL MARKING.

PC156

R305

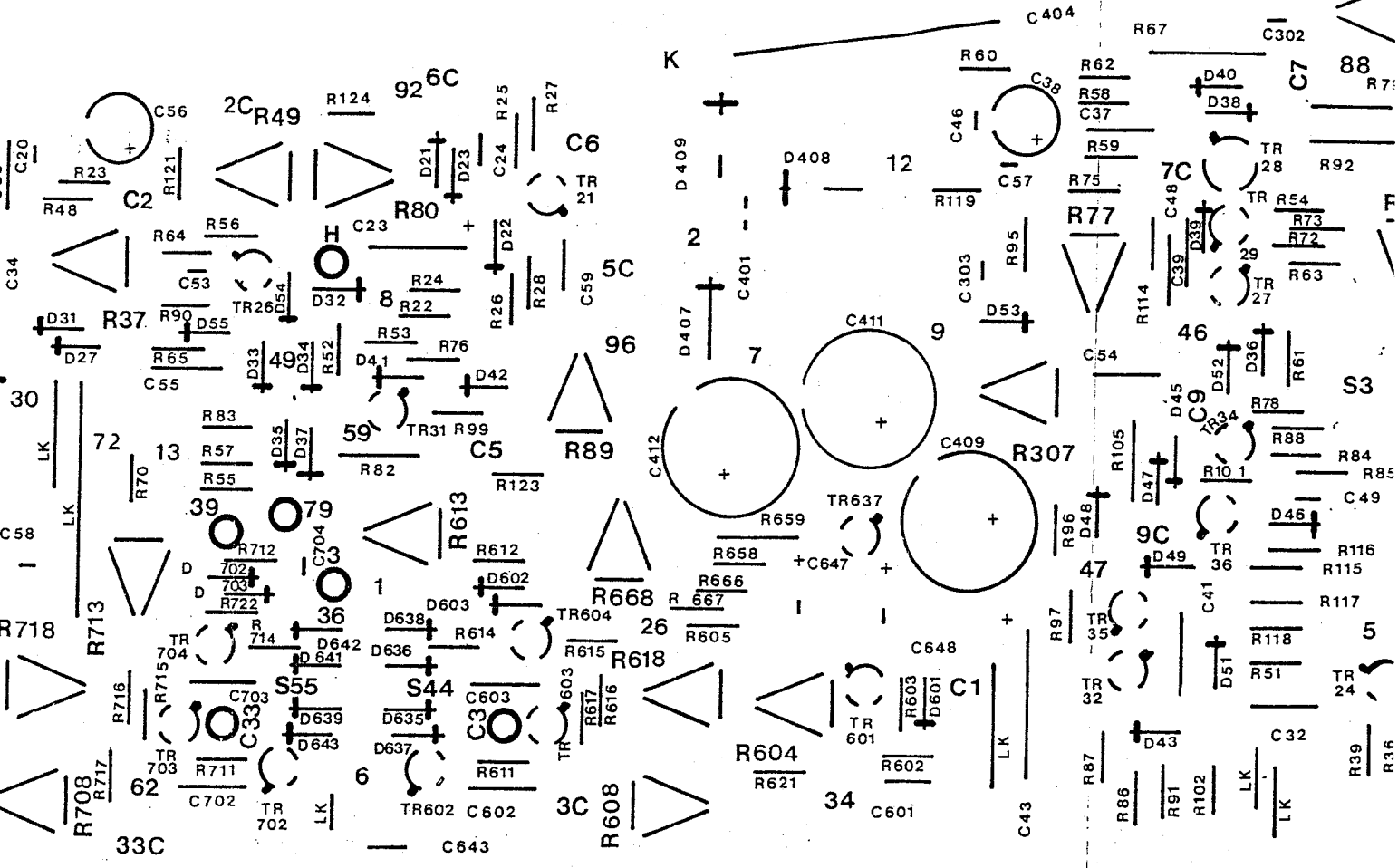

PC 226

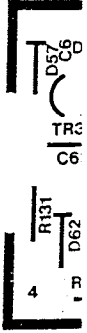

Note. C2 is mounted on TIME/DIV switch.

PRE-SET CONTROLS

PC.156

For Service Manuals Contact
MAURITRON TECHNICAL SERVICES
8 Cherry Tree Rd, Chinnor
Oxon OX9 4QY
Tel:- 01844-351694 Fax:- 01844-352554
Email:- enquiries@mauritron.co.uk

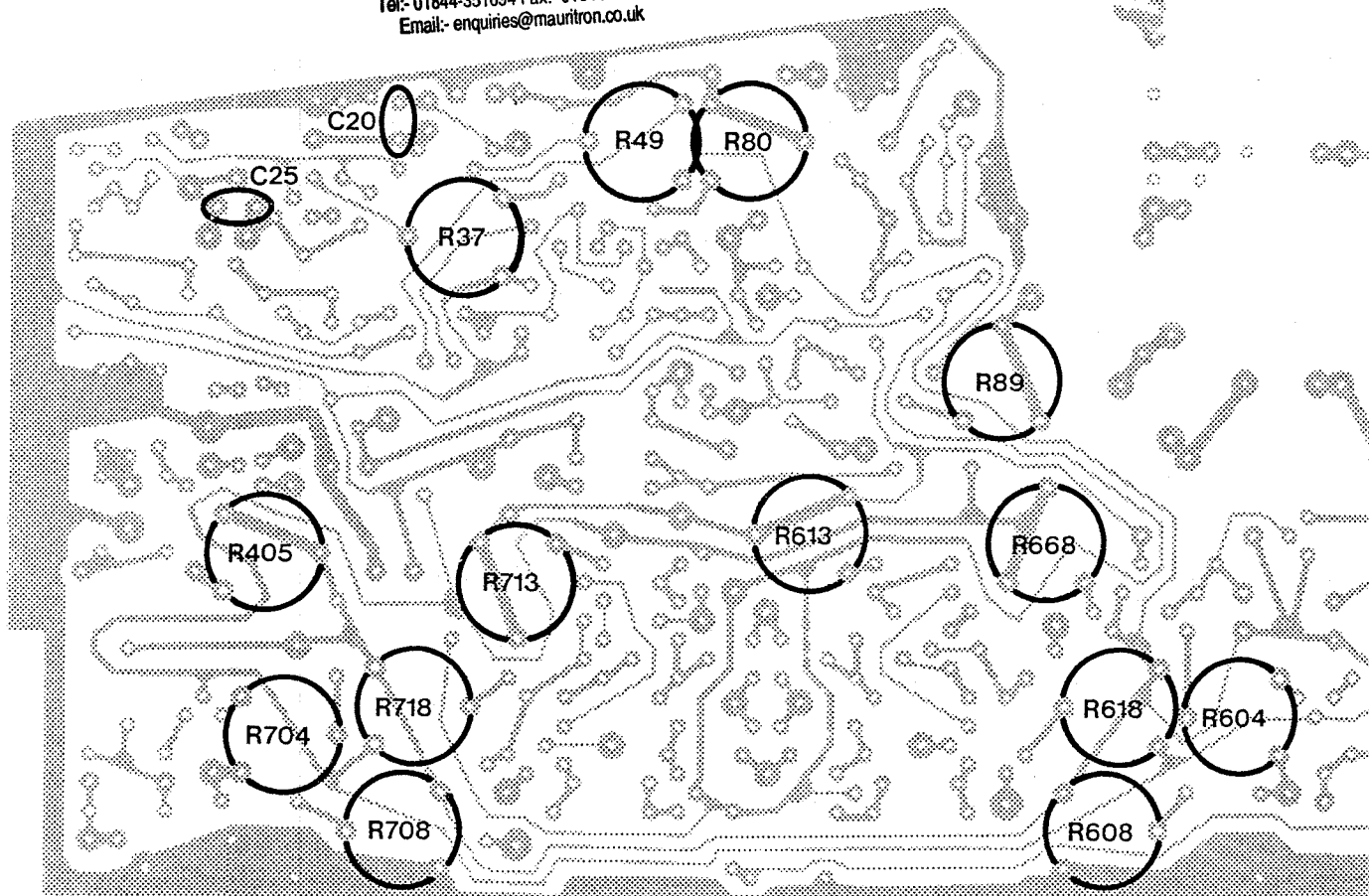

CH1

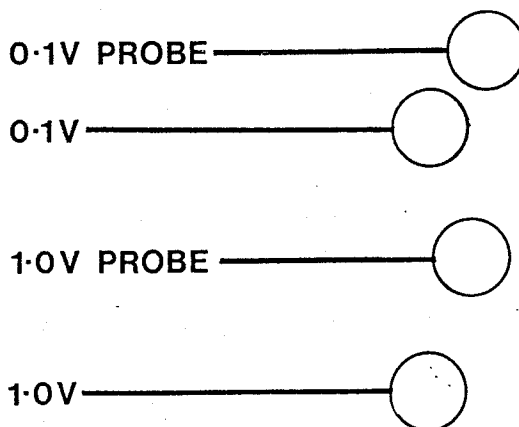

ATTENUATOR TRIM

switch.

PRE-SET CONTROLS

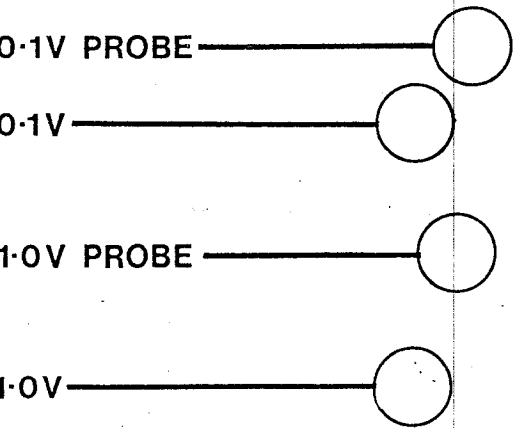
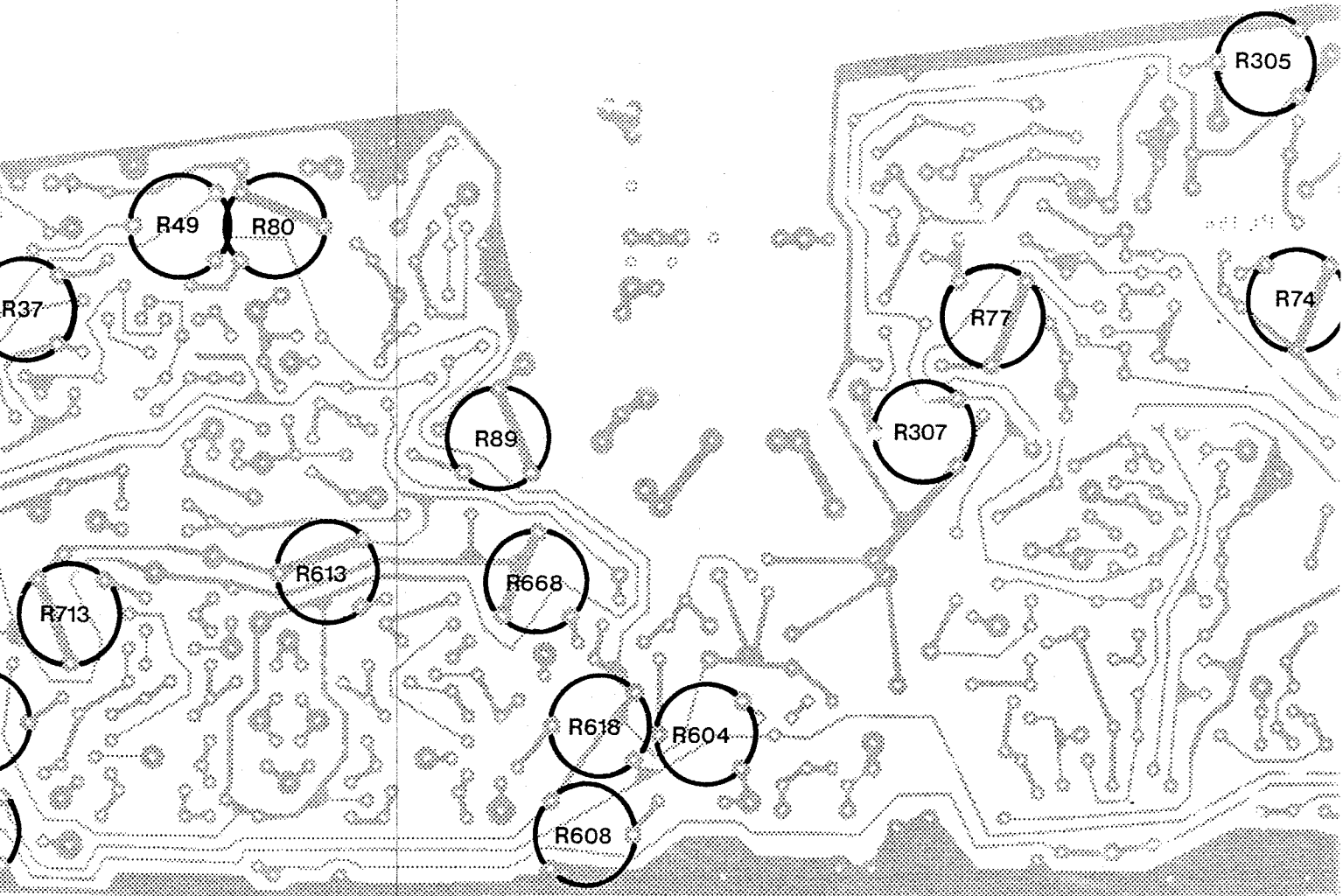

ATTENUATOR TRIMMER POSITIONS

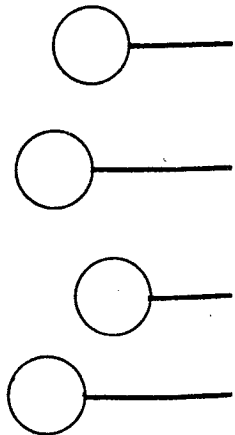

For Service Manuals Contact
MAURITRON TECHNICAL SERVICES
8 Cherry Tree Rd, Chinnor
Oxon OX9 4QY
Tel:- 01844-351694 Fax:- 01844-352554
Email:- enquiries@mauritron.co.uk

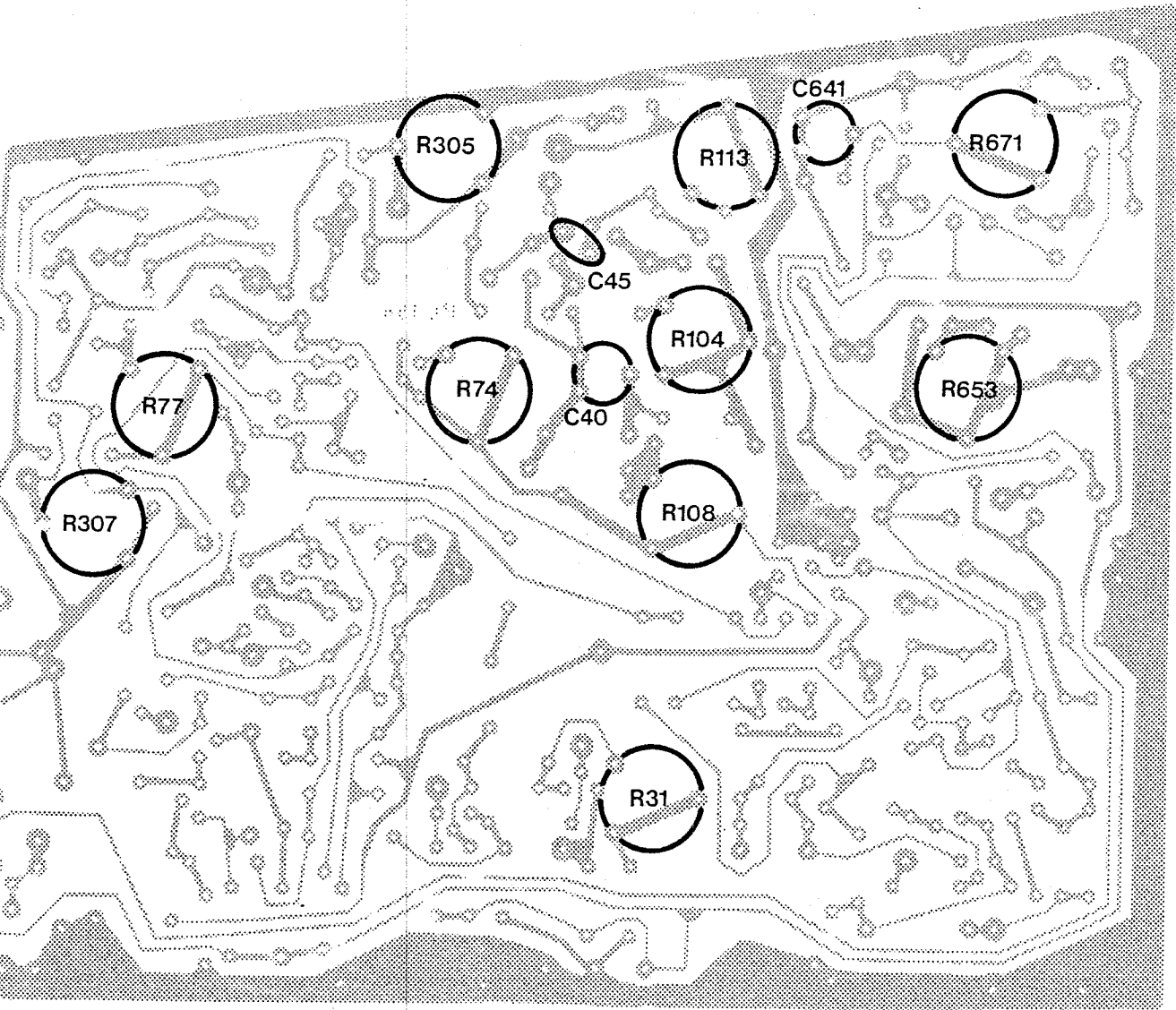

PROBE POSITIONS

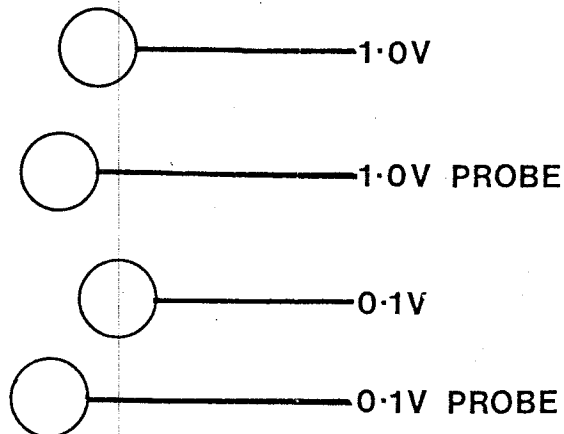

CH 2

a

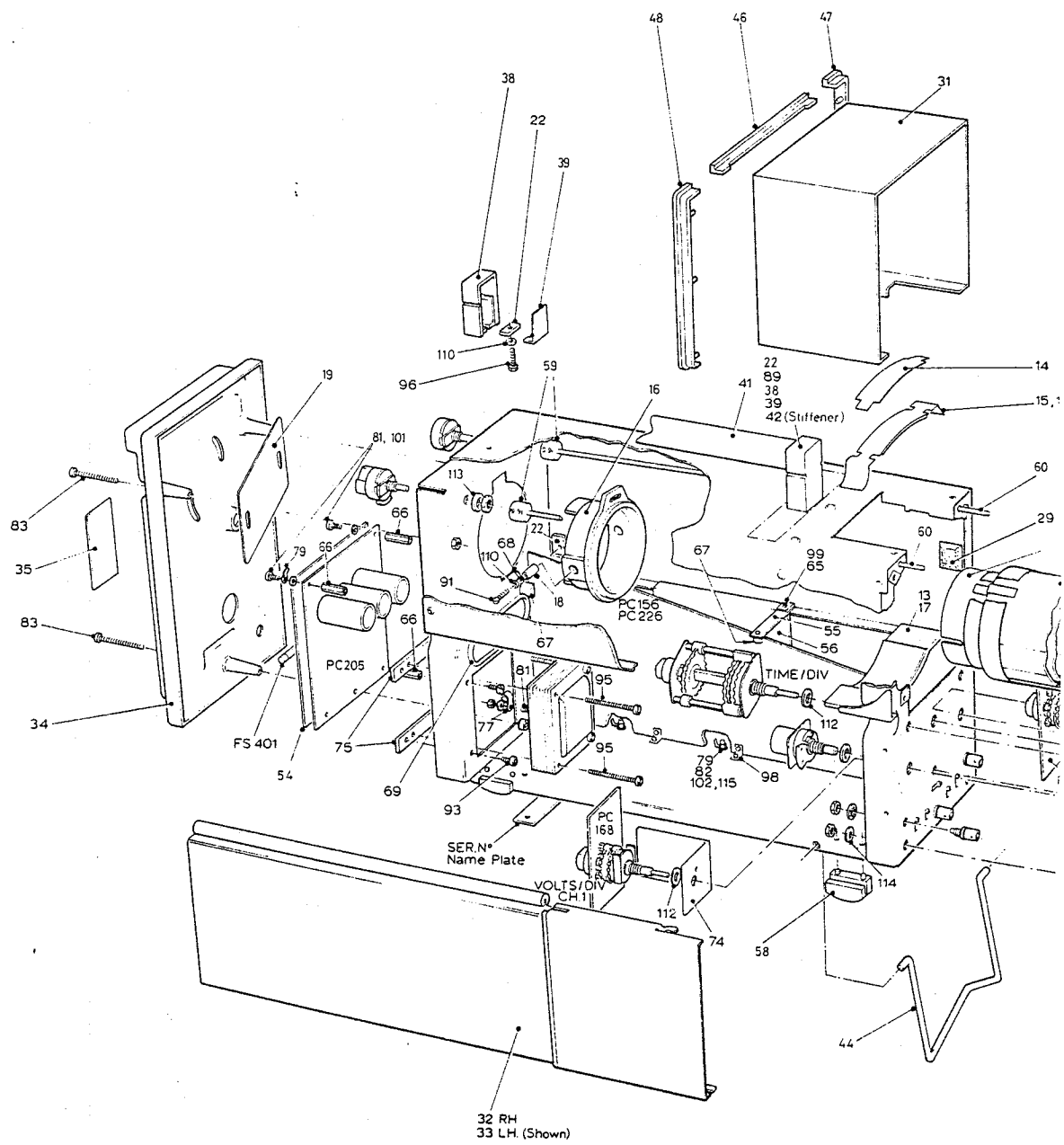

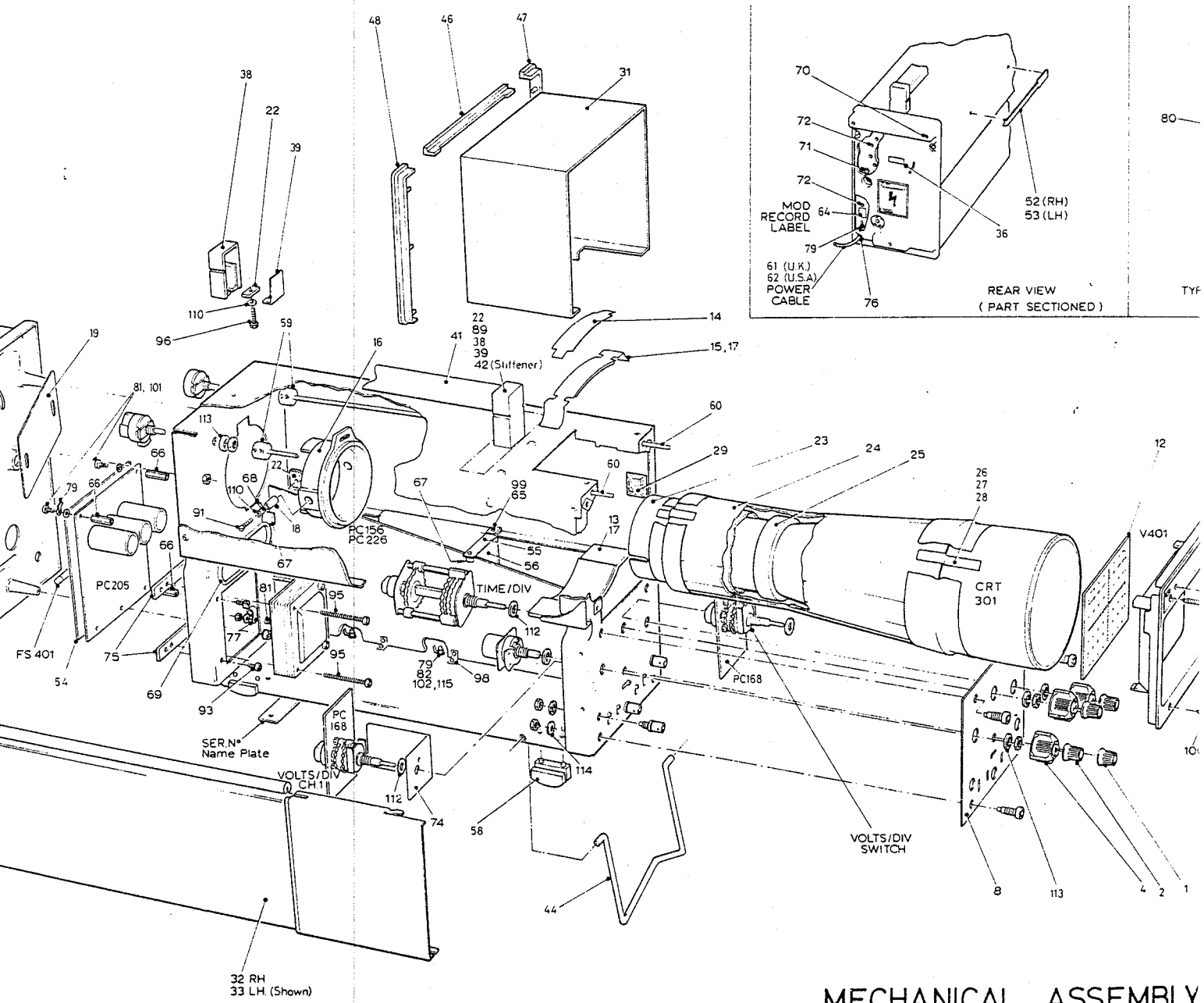

MECHANICAL ASSEMBLY D61A

For Service Manuals Contact
MAURITRON TECHNICAL SERVICES
 8 Cherry Tree Rd, Chinnor
 Oxon OX9 4QY
 Tel: 01844-351694 Fax: 01844-352554
 Email: enquiries@mauritron.co.uk

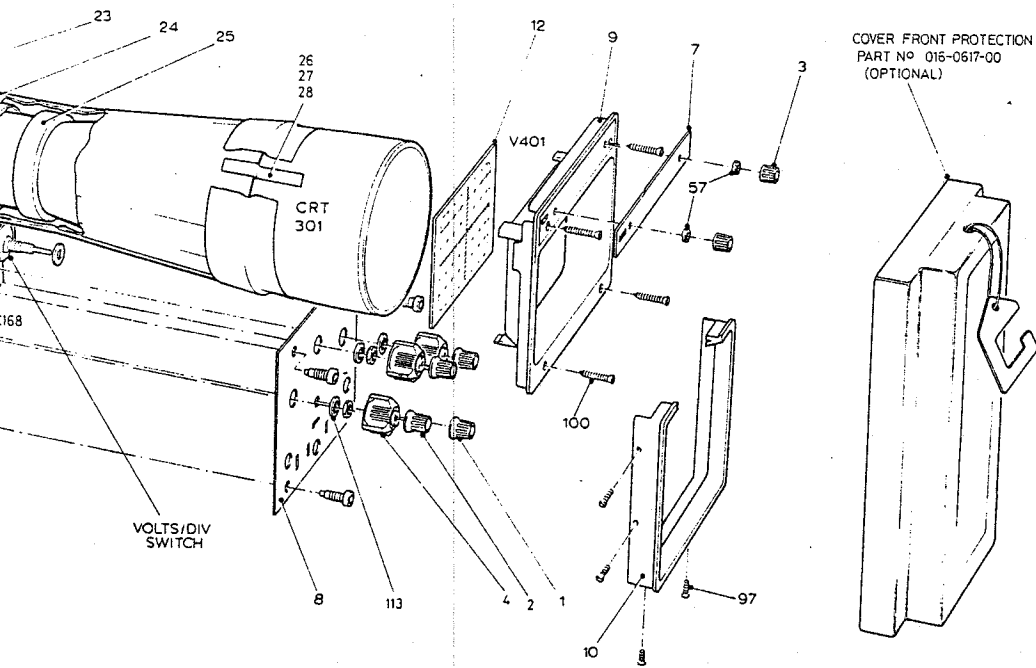
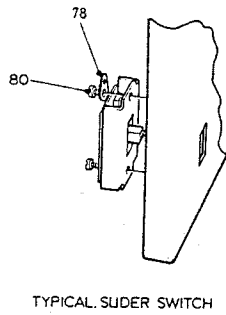
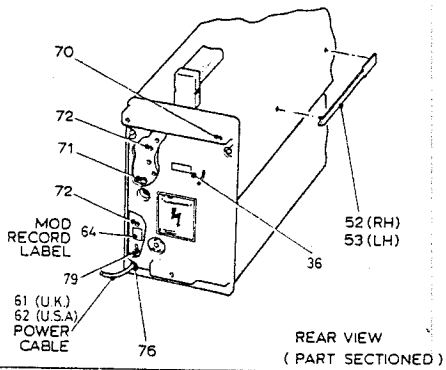

MECHANICAL ASSEMBLY
D61A

B

For Service Manuals Contact
MAURITRON TECHNICAL SERVICES
 8 Cherry Tree Rd, Chinnor
 Oxon OX9 4QY
 Tel:- 01844-351694 Fax:- 01844-352554
 Email:- enquiries@mauritron.co.uk

RESISTORS	669	631 632	672 673	634	644	633	639	642 643	640
			635		636 637		641	674 638	
CAPACITORS	631	649	630 635	632	633	634	652 639	640	637 653
									636
MISC.		L632 SI-2F S631 D632	TR631	D645 D631	D633	TR632 SI-2F D646	L631 D634		S632

For Service Manuals Contact
MAURITRON TECHNICAL SERVICES
 8 Cherry Tree Rd, Chinnor
 Oxon OX9 4QY
 Tel: 01844-351694 Fax: 01844-352554
 Email: enquiries@mauritron.co.uk

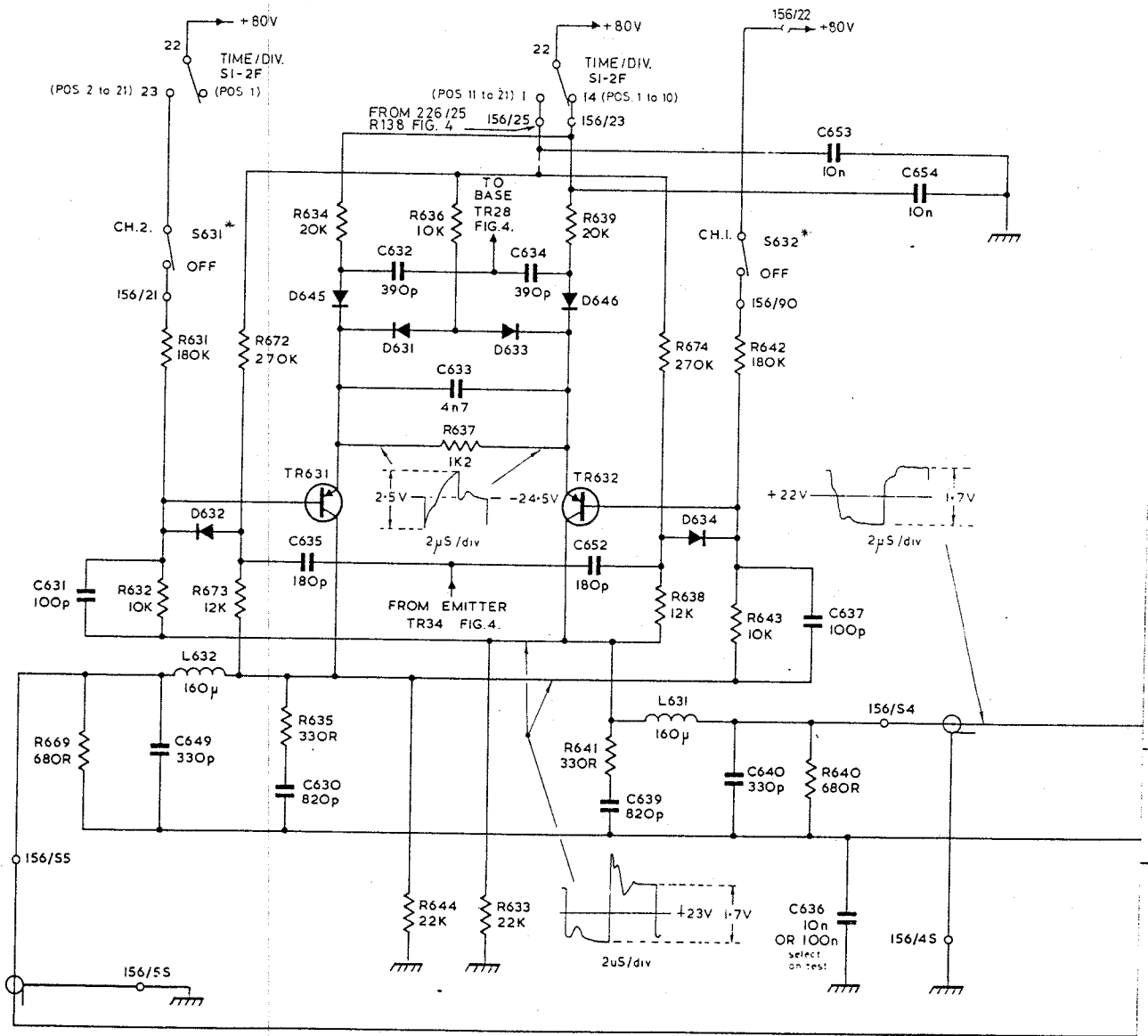

- NOTES.
- * DENOTES COMPONENTS NOT MOUNTED ON P.C. BOARD.
 - 156/55 DENOTES P.C. BOARD/EYELET OR TERMINAL No. CONNECTION.
 - ALL WAVEFORMS MEASURED WITH CAL WAVEFORM FED TO BOTH CHANNELS VOLTS / DIV SET TO 0.1 TRIG SELECTOR TO CH.1 AND TIME / DIV TO 2ns.

639 641 642 640
643
674 638
652 639 640 637 654
653 636
TR632 L631
-2F D634
D646 5632

664 661 647 649 645 651
653 663 648
645 64
64
TR636 TR633 TR634
D635 D638 D643 D641
D637 D636 D639 D642

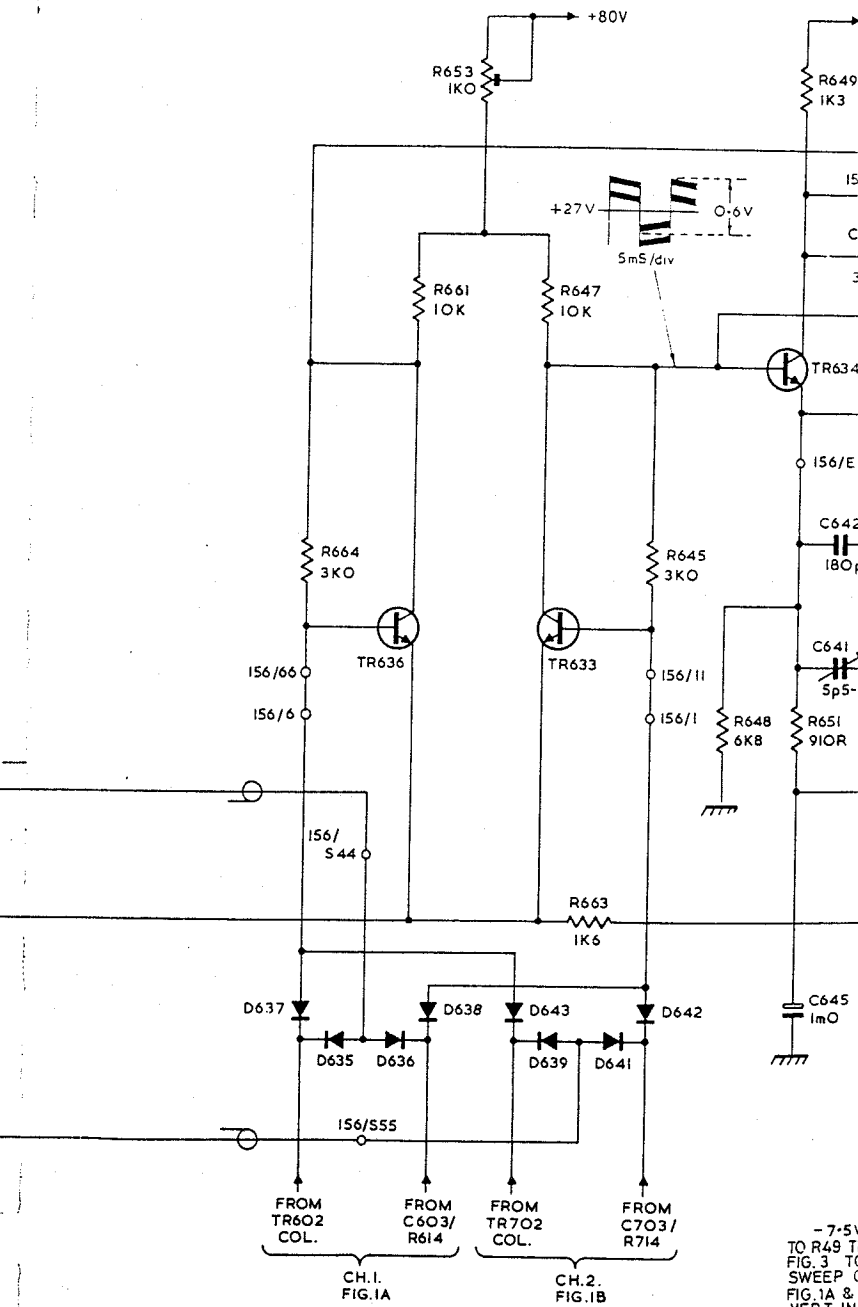
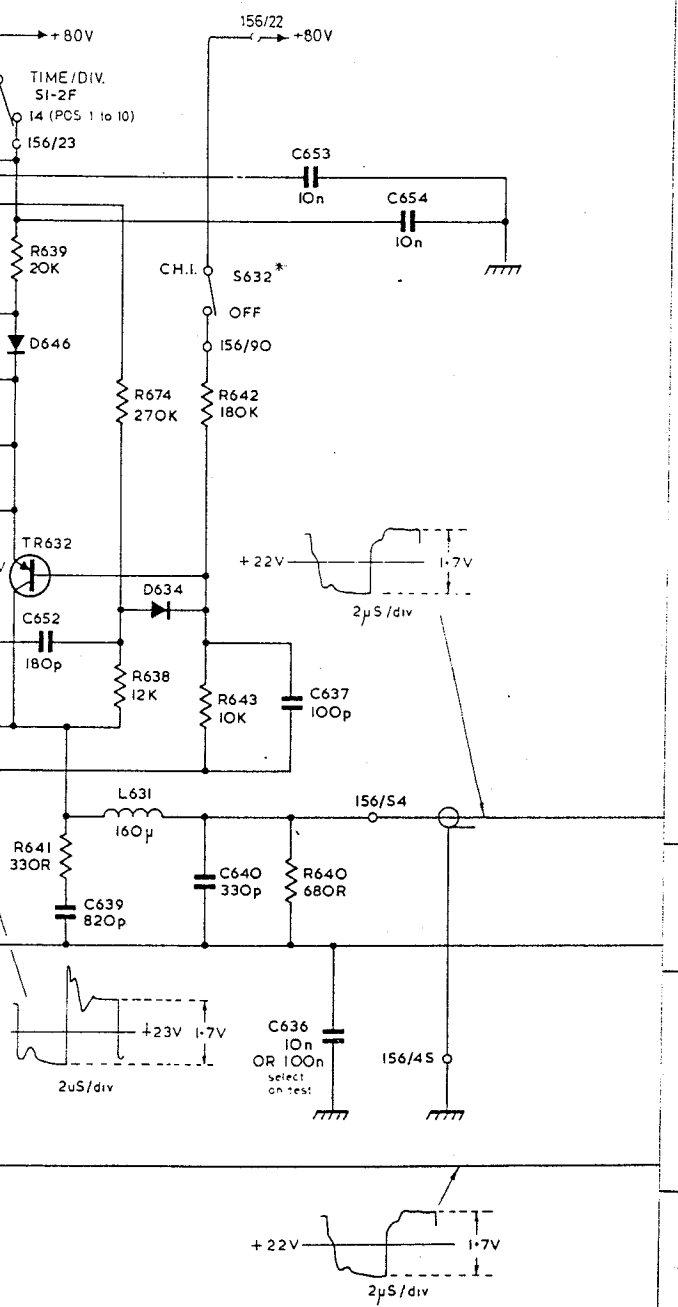

P.C. BOARD.
MINIMAL No. CONNECTION.
M FED TO BOTH CHANNELS
I AND TIME /DIV TO 2ms.

-7.5V
TO R49 TR
FIG. 3 TC
SWEEP C
FIG. 1A &
VERT IN:

'Y' AMPLIFIER - I
FIG. 2.

664	661	653	647	645	648	649	652	654	655	657	659
			663			651		658	656		
							671		668		
							665		667		
									666		
						645	638	647	644		
						642	646				
						641	648				643
	TR636	TR633				TR634		TH631	TR635		
D635	D638	D643	D641								
D637	D636	D639	D642						TR637		
								D644			

For Service Manuals Contact
MAURITRON TECHNICAL SERVICES
 8 Cherry Tree Rd, Chinnor
 Oxon OX9 4QY
 Tel:- 01844-351894 Fax:- 01844-352554
 Email:- enquiries@mauritron.co.uk

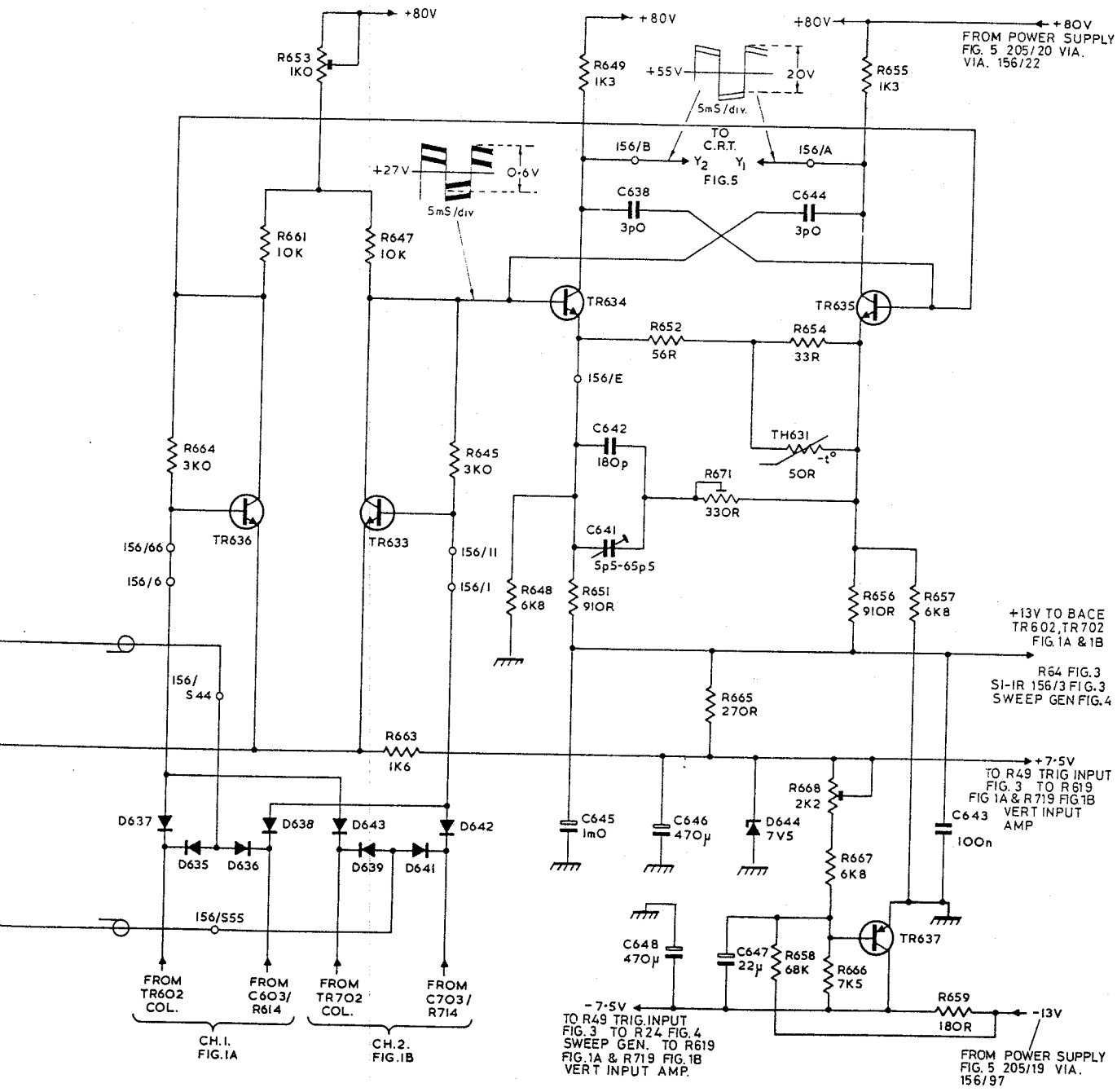

'Y' AMPLIFIER - D61A
 FIG. 2.

RESISTORS	23	37	32	34	38	44	46	48	49
	120	121	122	125		126	52		
CAPACITORS	21	3	20				51		
								30	
MISC.	TH20			FB23	TR23	TH21	TR25		D31
	SK21	S20	SI-IF	SI-IR	S21	D24	D26	D27	D28
						D25	D29		

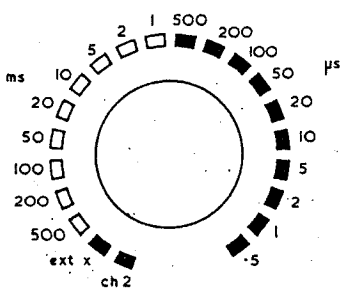
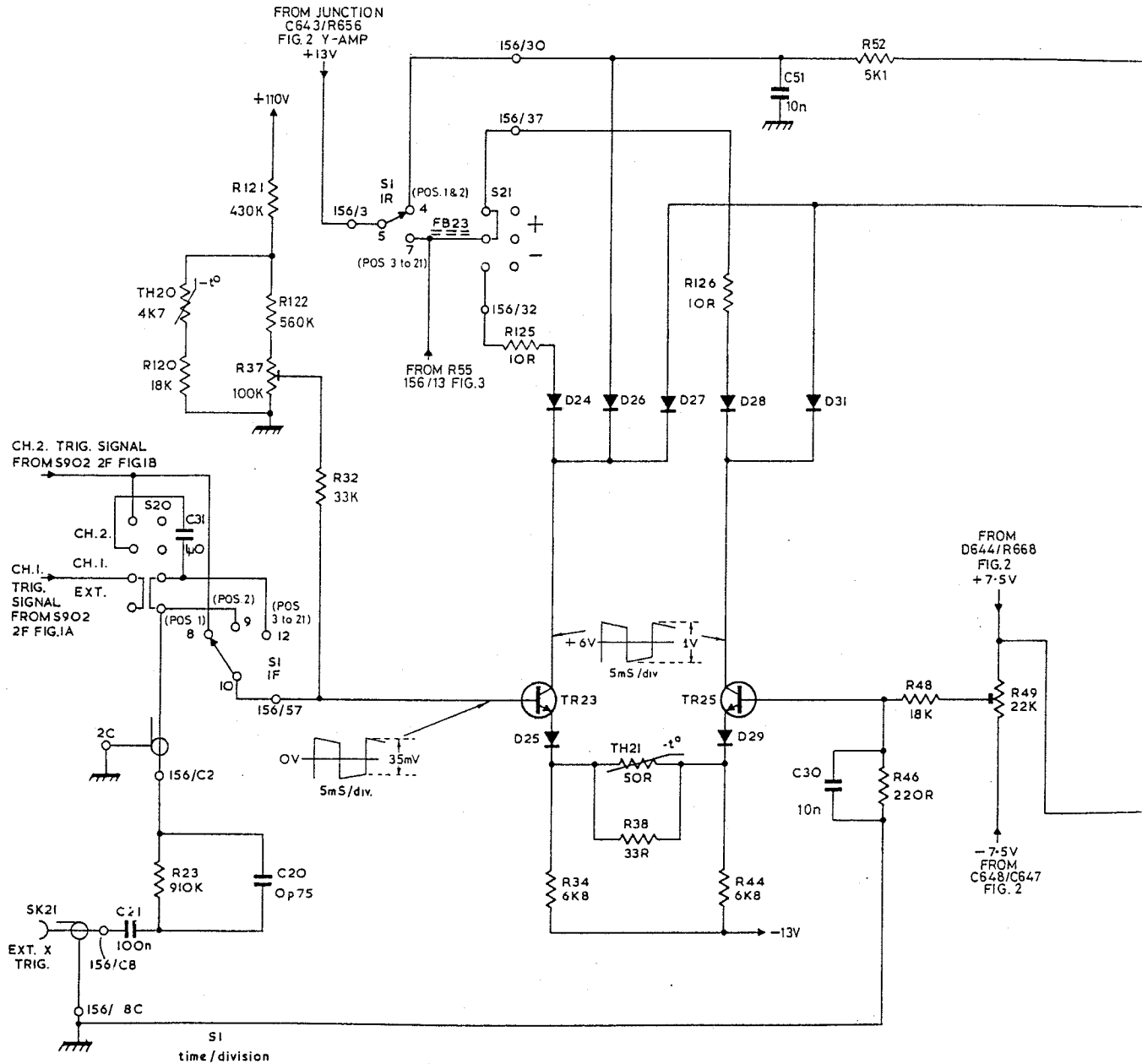

FRONT PANEL MARKING

NOTES.

- * DENOTES COMPONENTS NOT MOUNTED ON P.C. BOARD.
- 156/C8 DENOTES P.C. BOARD/EYELET OR TERMINAL No. CONNECT!
- SWITCH SHOWN IN FULLY ANTI-CLOCKWISE POSITION.
- FOR SI SWITCH WAFERS SEE FIG.6.
- ALL WAVEFORMS MEASURED WITH CAL WAVEFORM FED TO BOTH CHANNELS VOLTS/DIV. TO 0-1 TRIG SELECTOR TO CH.1 AND TIME/DIV TO 2mS.

53	80 56 57	55 83	66	68 64 65	99 89	76	82	79 81	92 93 94	104	109 107 108	111 112 113
123		56	55 58	53	70				98		45	44
D32	TR26 D54 D33 D35	D55 D34 D37	S23	D41 TR31 D42				TR33 D44			TR37	

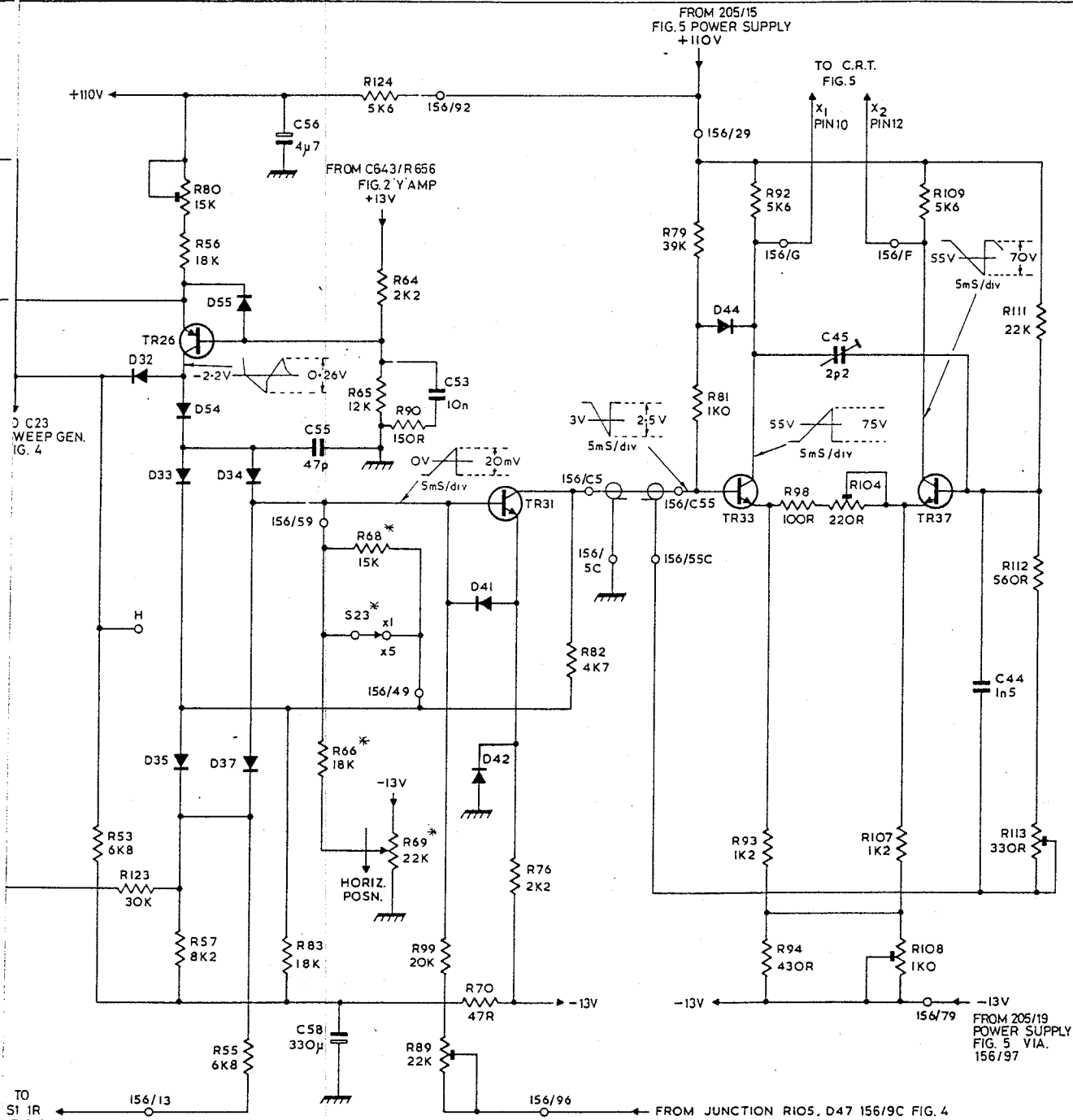

TRIG INPUT & HORIZONTAL AMP D61A
FIG. 3.

84	88	6	72	IO1	IO5	114	95	115	IO2	96	97	91	54	86
85		5					75	116					62	87
	61	4	77				73	117					58	67
	78	3					74	118					59	
	63	2											60	119
52		1												
		39												
D36	D52	D53	SI-2R	SI-3R	D46	SI-3F	D48	D51	D49				D40	
SK22	D45				TR36	D47							D38	D43
TR34	TR27				D39		TR29		TR35	D50	TR32		TR28	

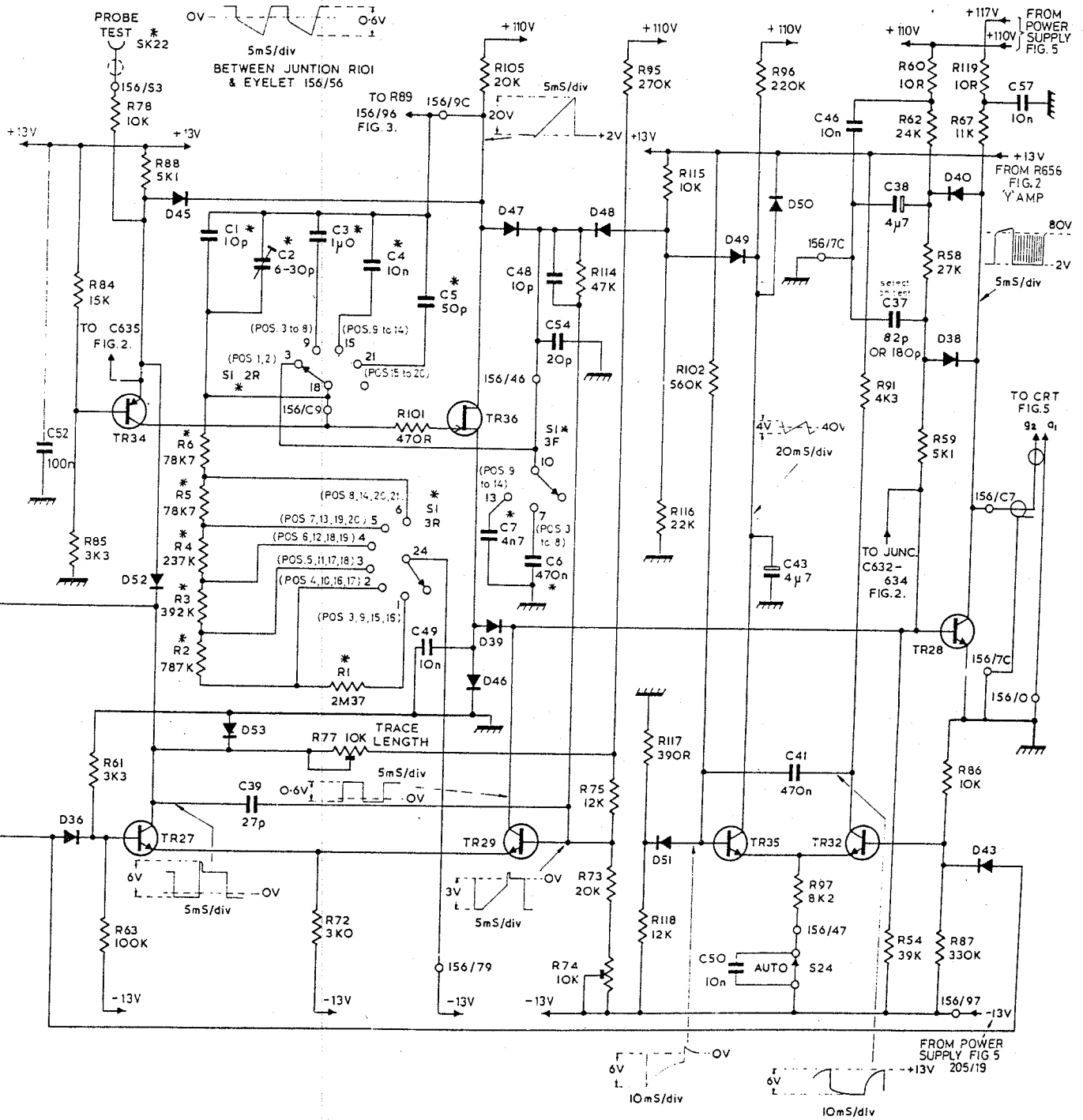

SWEEP GENERATOR D61A
FIG. 4.

For Service Manuals Contact
MAURITRON TECHNICAL SERVICES
8 Cherry Tree Rd, Chinnor
Oxon OX9 4QY
Tel: 01844-351694 Fax: 01844-352554
Email: enquiries@mauritron.co.uk

RESISTORS				402	403	404	400	406		
						405		407		
								408		
									401	
CAPACITORS				401	402	403	404	405	406	408
MISC.							407			
	S401	FS401	SK401	T401	D401	D402	D408	D409	D413	SK402
					D404	D403	D411	D412	V401	
					D405	D406	D407			

NOTE
C407 IS ONLY FITTED WHEN HUM IS VISIBLE AT ENDS OF TRACE ON 2ms DIV WITH 1ms MARKERS.

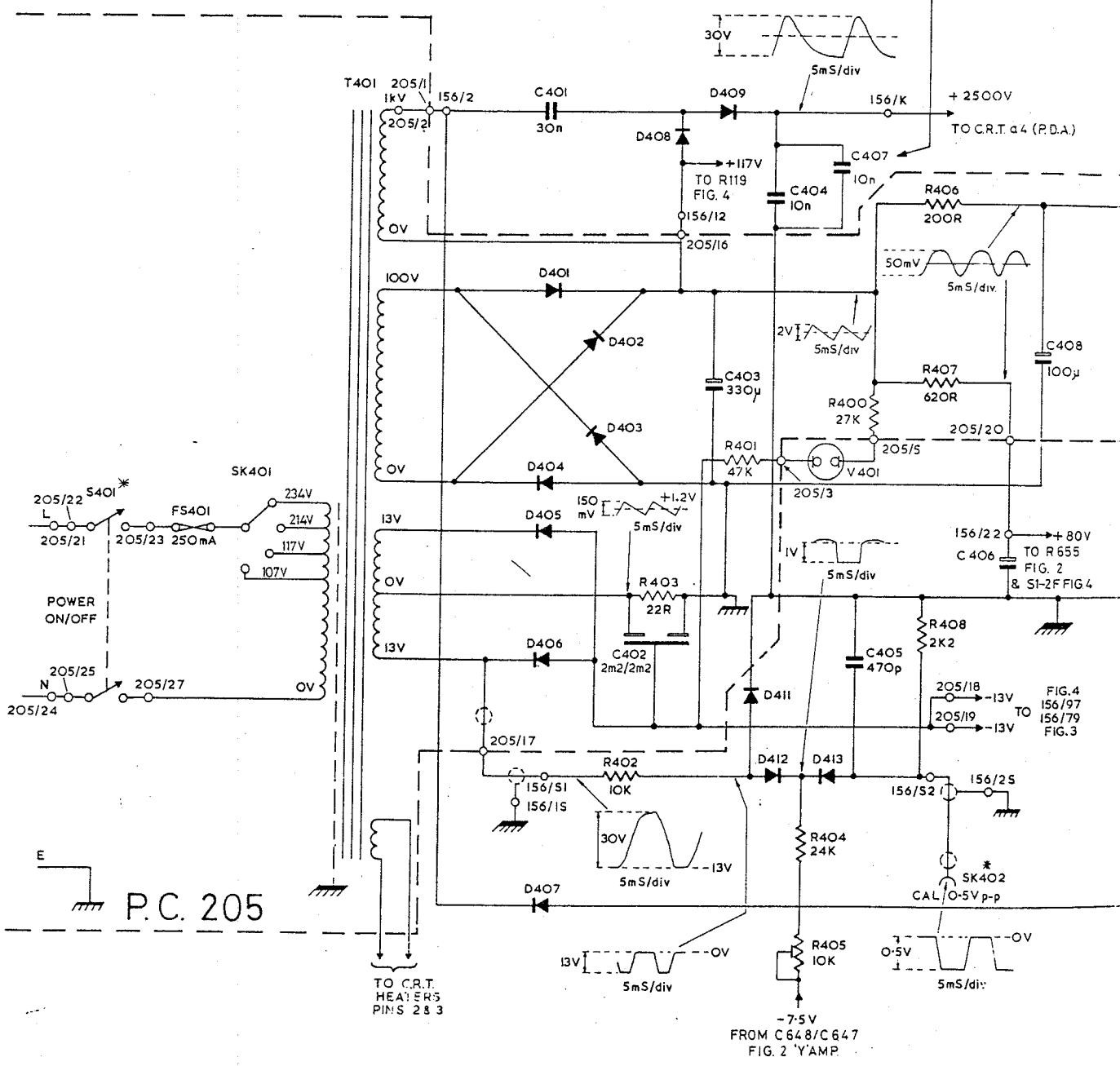

- NOTES.
- * DENOTES COMPONENTS NOT MOUNTED ON P.C. BOARD.
 - 156/2 DENOTES P.C. BOARD/EYELET OR TERMINAL No. CONNECTION
 - ALL WAVEFORMS MEASURED WITH CAL. WAVEFORM FED TO BOTH CHANNELS. VOLTS/DIV. SET TO 0.1, AND TRIG. SELECTOR TO CH.I. AND TIME/DIV. TO 2ms.

For Service Manuals Contact
MAURITRON TECHNICAL SERVICES
 8 Cherry Tree Rd, Chinnor
 Oxon OX9 4QY
 Tel: 01844-351694 Fax: 01844-352554
 Email: enquiries@mauritron.co.uk

402	403	404	400	406		401	301	305
		405		407			302	300
	401						303	
401	402	403	404	405	406	408	304	
			407					
D401	D402	D408	D409	D411	D413	SK402		304
D404	D403		D412	V401				
D405								
D406	D407							

NOTE
C407 IS ONLY FITTED WHEN HUM IS VISIBLE AT ENDS OF TRACE ON 2mS DIV WITH 1mS MARKERS.

For Service Manuals Contact
MAURITRON TECHNICAL SERVICES
8 Cherry Tree Rd, Chinnor
Oxon OX9 4QY
Tel: 01844-351694 Fax: 01844-352554
Email: enquiries@mauritron.co.uk

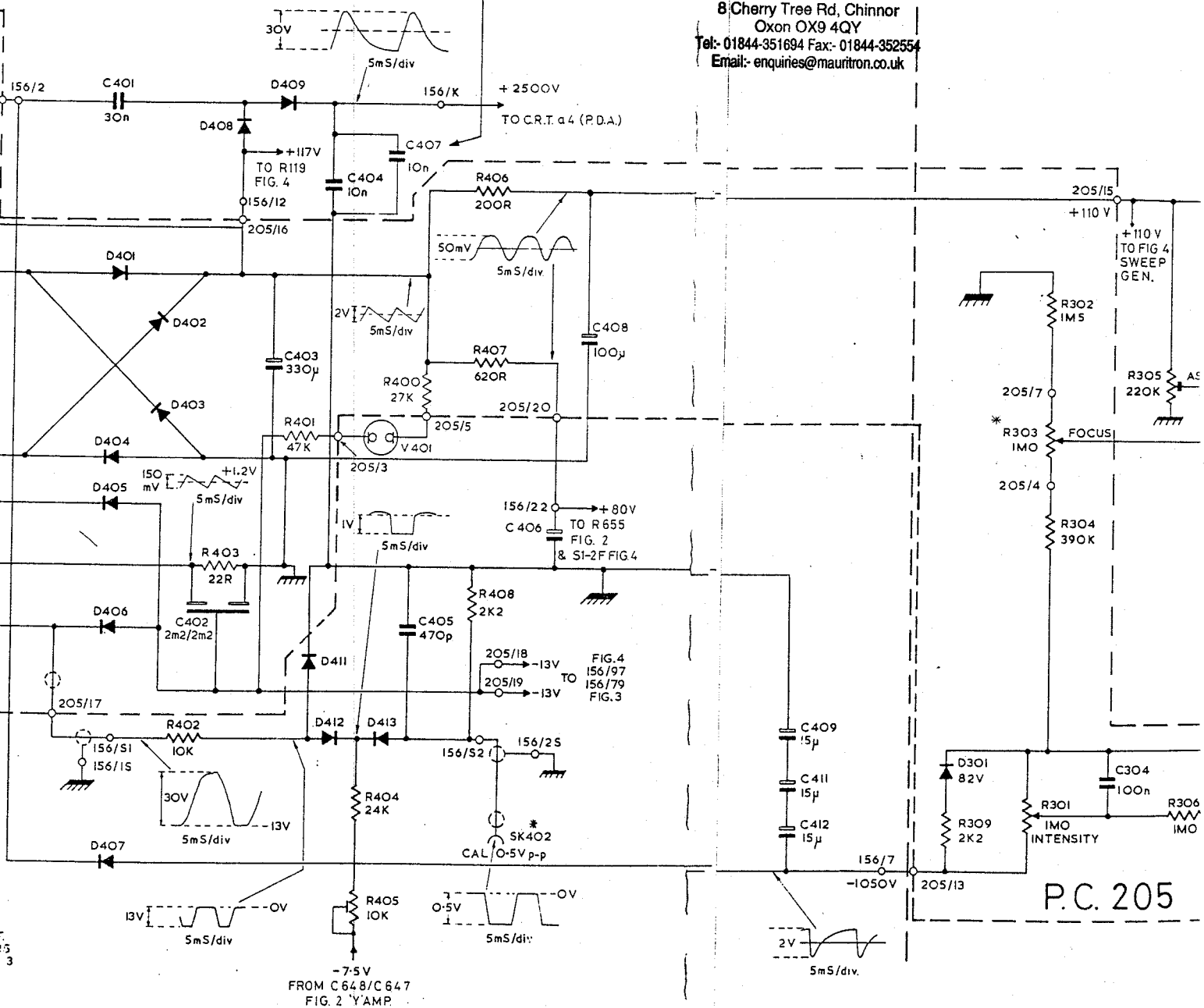

MOUNTED ON P.C. BOARD.
YELET OR TERMINAL No. CONNECTION
TH CAL. WAVEFORM FED TO BOTH
O-1, AND TRIG. SELECTOR TO CH.1.

POWER SUPPLY
FIG. 5

401	301 302 303 304	305 306	307 308
409 411 412	309	304	302 301
V401	D301	SK301	V301

For Service Manuals Contact
MAURITRON TECHNICAL SERVICES
 8 Cherry Tree Rd, Chinnor
 Oxon OX9 4QY
 Tel:- 01844-351694 Fax:- 01844-352554
 Email:- enquiries@mauritron.co.uk

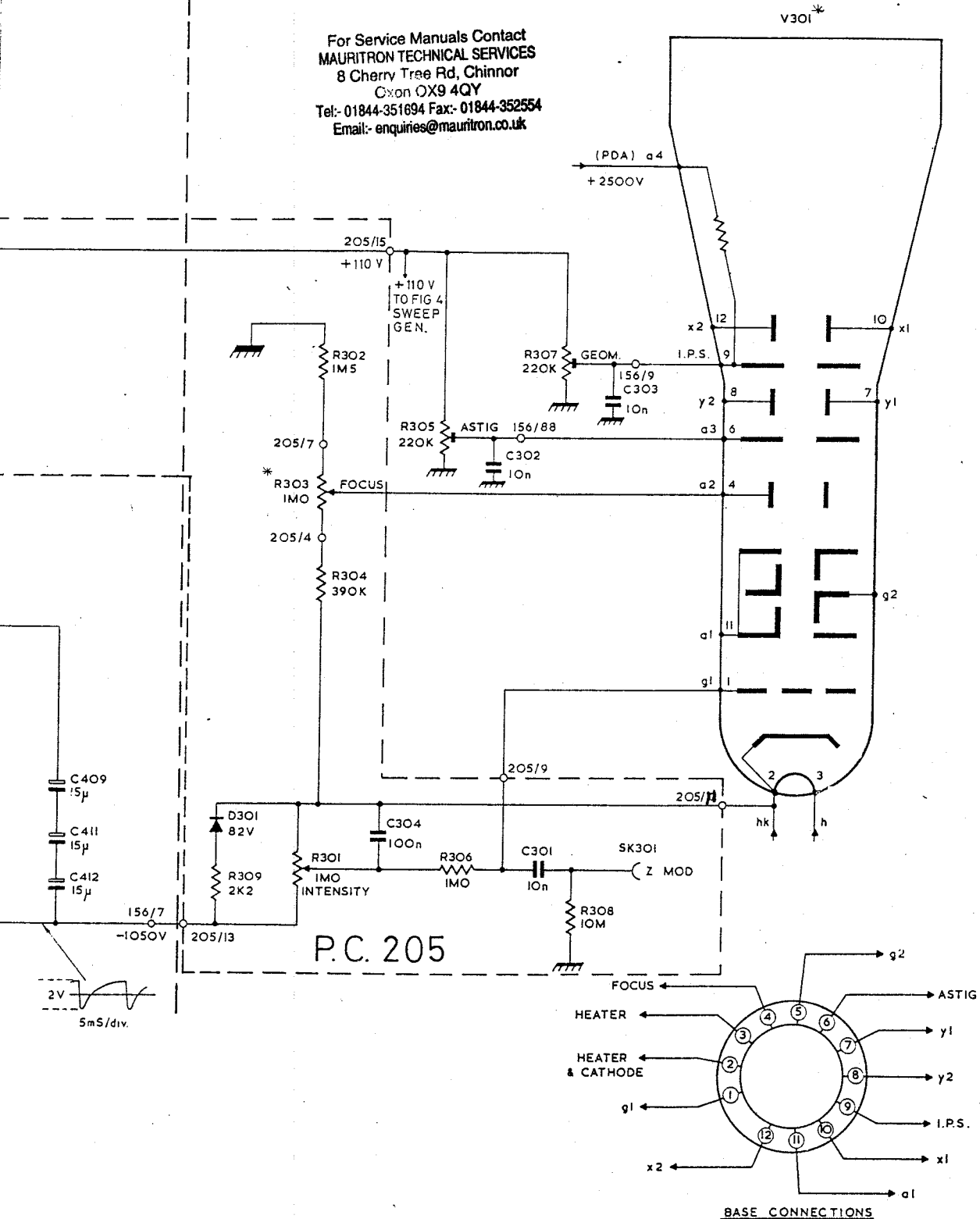

POWER SUPPLY & C.R.T. — D61A
 FIG. 5