

44

Accuphase

STEREO POWER AMPLIFIER P-300

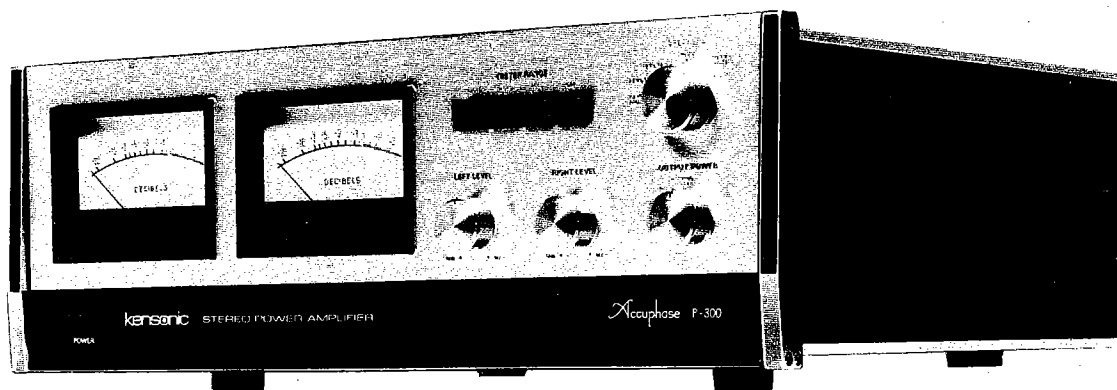

Service Information

STARTING WITH SERIAL NO. H3Y101

TABLE OF CONTENTS

BLOCK DIAGRAM	1
EXTERNAL VIEW	2
INTERNAL VIEW	3
EXPLODED VIEW	4
MISCELLANEOUS	6
CIRCUIT DESCRIPTION	7
MAIN DRIVE AMP. ASSEMBLY	10
PROTECTION CIRCUIT ASSEMBLY	12
POWER SUPPLY ASSEMBLY	14
POWER AMP. ASSEMBLY	15
PUSH BUTTON SWITCH ASSEMBLY	15
HOW TO REPLACE POWER TRANSISTORS	16
RESISTOR COLOR CODE	17
TRANSISTOR LEADS	18
SCHEMATIC DIAGRAM	19
SPECIFICATIONS	21

BLOCK DIAGRAM

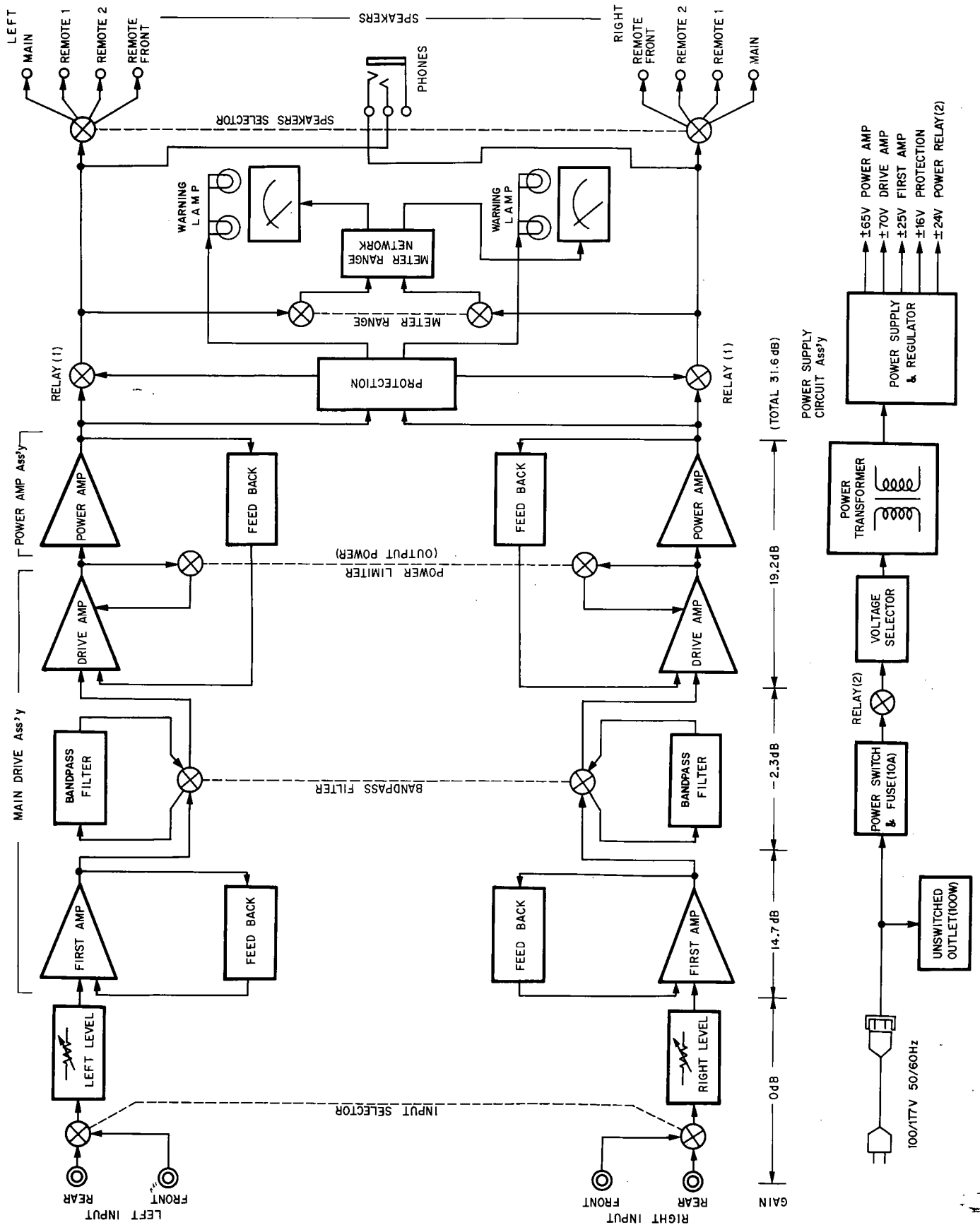

EXTERNAL VIEW

FRONT

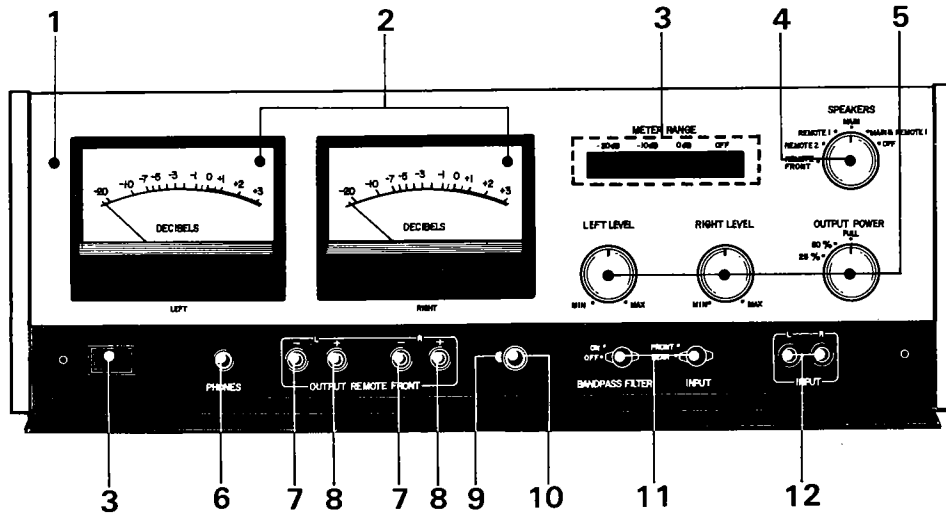

REAR

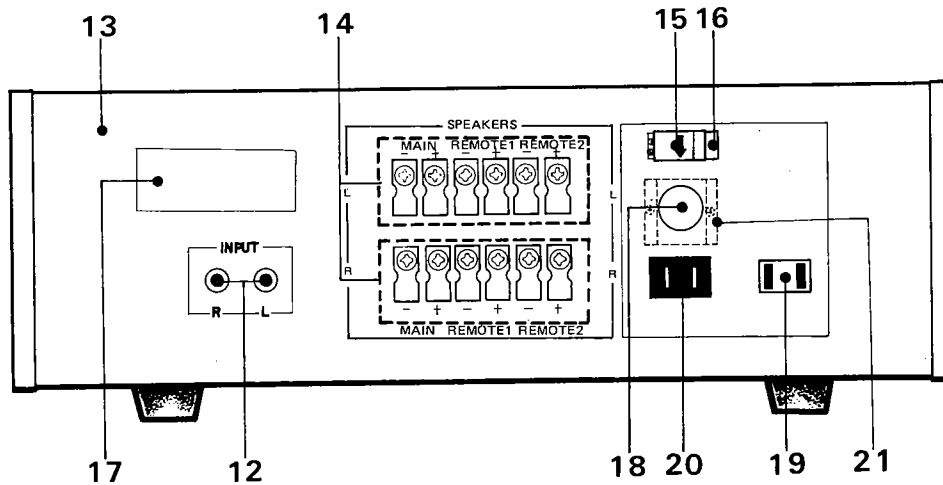

PARTS LIST

Ref. No.	Description	Part No.	Remarks
1	Front Panel Assembly	130-0002-02	
2	Power Meter	178-2001-00	
3	Push button	389-5001-04	
4	Knob	381-3001-04	
5	Knob	381-2601-04	
6	Headphone Jack	302-1201-00	
7	Banana Jack	302-5001-00	Black
8	Banana Jack	302-5021-00	Red
9	Push button	389-1202-04	with Magnet
10	Magnet	271-0001-00	with Push button
11	Knob	384-1101-04	
12	PinJack	302-0201-00	2-pin
13	Back Panel	135-0002-02	
14	Speaker Terminal	313-5061-00	for out put
15	Voltage Selector Plug	301-4001-00	
16	Voltage Selector Fixed Bracket	248-0001-04	
17	Set Name Plate	180-0002-04	
18	FuseHolder	306-0501-00	for MAIN fuse
19	AC Outlet	305-1201-00	
20	AC Connector Plug	301-3201-00	
21	Fuse Holder Cover	253-0001-04	

INTERNAL VIEW

TOP SIDE

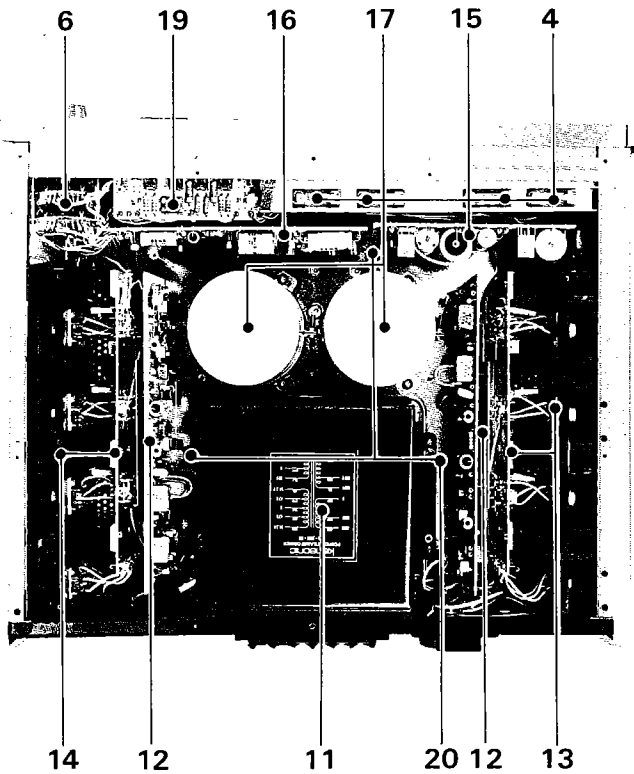

BOTTOM SIDE

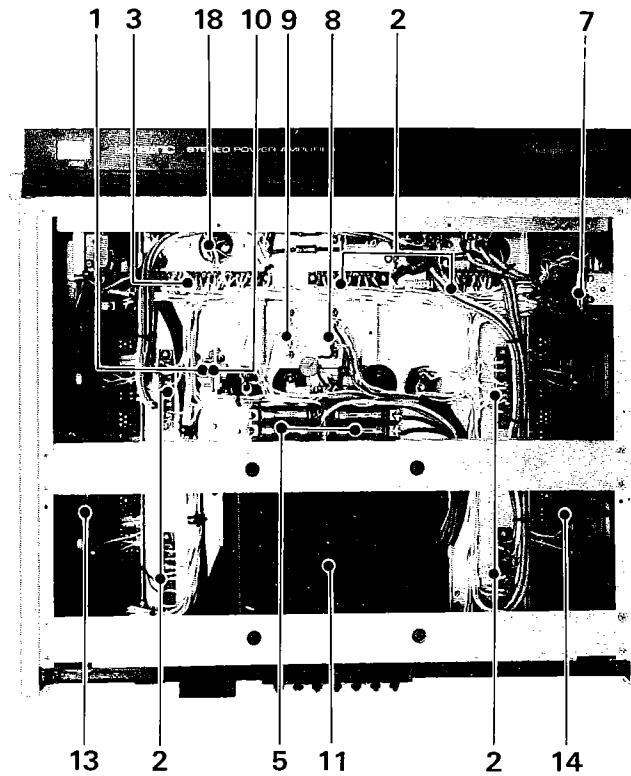

PARTS LIST

Ref. No.	Description	Part No.	Remarks
1	Transistor Socket	300-0101-00	for 2SD130
2	Printed Circuit Board Connector	303-1001-00	10-pin
3	Printed Circuit Board Connector	303-1801-00	18-pin
4	Fuse Holder	306-1001-00	for Pilot Lamps
5	Fuse Holder	306-1501-00	
6	Rotary Switch	335-6001-00	SPEAKERS
7	Relay	362-2201-00	for Protection
8	Silicon Diode	SG-5T (+)	Red: for Rectifier
9	Silicon Diode	SG-5T (-)	Black: for Rectifier
10	Transistor NPN	2SD130	
11	Power Transformer	510-2001-00	
12	Main Drive Assembly	710-0001-00	
13	Power AMP. Assembly (L)	717-0001-00	
14	Power AMP. Assembly (R)	717-0002-00	
15	Power Supply Assembly	719-0002-00	
16	Protection Circuit Assembly	720-0001-00	
17	Electrolytic Capacitor 40000 μ F 63WV	CE33W1J403	C1, 2
18	Electrolytic Capacitor 2200 μ F 35WV	CE62W1V222LG	C5
19	Push button Assembly	716-0004-00	for METER RANGE
20	Hexa Head Boss	251-6951 14	

EXPLODED VIEW

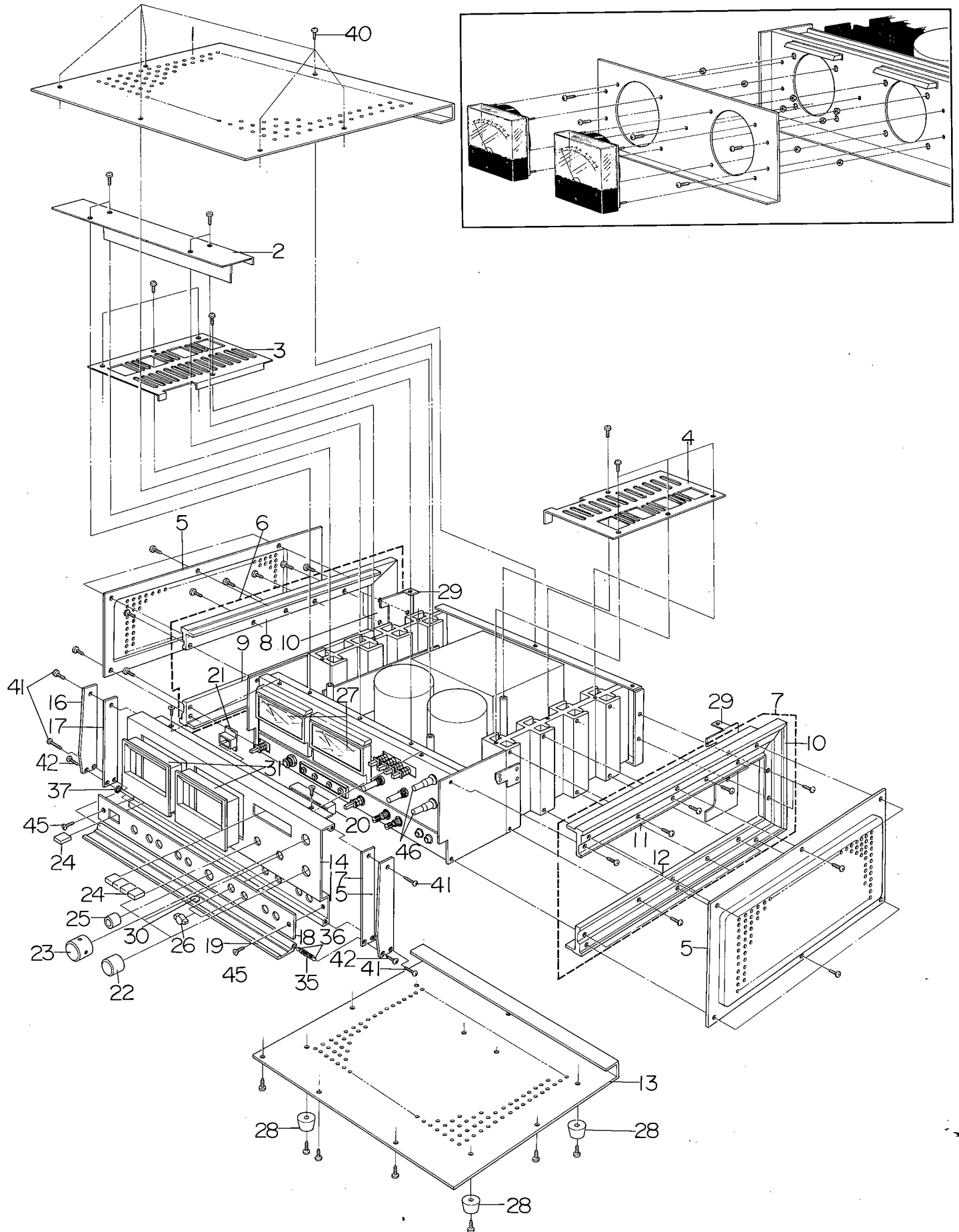

PARTS LIST

Ref. No.	Description	Part No.	Remarks
1	Top Plate	150-0002-02	for Upper Side
2	Shield Cover	230-0004-02	for Sub Chassis
3	Shield Cover (L)	231-0002-00	for Left Side POWER AMP
4	Shield Cover (R)	231-0003-00	for Right Side POWER AMP
5	Side Plate	151-0002-02	for Both Side
6	Frame Assembly (L)	112-0001-12	for Left Side
7	Frame Assembly (R)	112-0002-12	for Right Side
8	Frame A	112-1001-13	Frame Assembly (L): □ for Upper
9	Frame B	112-1002-13	Frame Assembly (L): Bottom □ for Bottom
10	Frame C	112-1003-04	Frame Assembly (L) (R): □ for Rear
11	Frame D	112-1004-13	Frame Assembly (R): Upper □ for Upper
12	Frame E	112-1005-13	Frame Assembly (R): Bottom □ for Bottom
13	Bottom Plate	155-0002-02	
14	Front Panel	131-0002-02	Front Panel Assembly:
15	Panel End Cap (R)	132-0002-00	Front Panel Assembly: □ for Right Side
16	Panel End Cap (L)	132-0001-00	Front Panel Assembly: □ for Left Side
17	Panel End Spacer	250-1001-14	Front Panel Assembly:
18	Panel Name Plate	180-1002-13	Front Panel Assembly:
19	Sub Panel	134-0002-12	Front Panel Assembly:
20	Push button Frame	113-0003-03	Front Panel Assembly:
21	Push button Frame	113-0002-04	for METER RANGE Front Panel Assembly:
22	Knob	381-2601-04	for POWER Switch
23	Knob	381-3001-04	for LEVER (R), (L), OUTPUT POWER
24	Push button	389-5001-04	for SPEAKER
25	Push button	389-1201-04	METER RANGE, POWER Switch
26	Knob	384-1101-04	for Sub Panel Magnet Opener
27	Power Meter	178-2001-00	for INPUT, BANDPASS FILTER
28	Rubber Foot	238-0001-04	
29	Frame Fixed Plate	244-0001-04	Frame Assembly (L) (R):
30	Catcher	272-0001-04	Front Panel Assembly:
31	Meter Frame	113-0004-03	Catch for Sub Panel Magnet Opener
35	Coil Spring	285-1001-04	Front Panel Assembly:
36	Ball Bearing	220-0301-00	Front Panel Assembly:
37	Nylon Washer	673-1031-50	Front Panel Assembly:
40	Binding Head B type Selftapping Screw	614-0306-02	3x6mm: Fixed for TOP, SIDE, BOTTOM, Plates
41	Pan Head B type Selftapping Screw	610-0314-01	Front Panel Assembly: 3x14mm Fixed for Panel End Cap Rear Side
42	Pan Head ISO Metric Screw	615-0312-01	Front Panel Assembly: 3x12mm Fixed for Panel End Cap Front Side
43	Binding Head ISO Metric Screw	600-0306-02	3x6mm: Fixed for Shield Cover with Hexa Head Boss
45	Binding Head B type Selftapping Screw	614-0310-00	3x10mm: Fixed for Front Panel Assembly
46	Shaft	203-5001-04	SPEAKERS, OUTPUT POWER

MISCELLANEOUS

PARTS LIST

Ref. No.	Description	Part No.	Remarks
	Rubber Sheet	250-2003-04	for Power Supply Relay (362-2202-00)
	Screw Cover	254-0301-00	for 3mm
	Screw Cover	254-0401-00	for 4mm
	Voltage Selector Jack	302-4001-00	
	Fuse 2A	310-0201-00	
	Fuse 10A SLO-BLO	310-9901-00	for MAIN fuse (at 100V, 120V)
	Fuse 5A SLO-BLO	310-1501-00	for MAIN fuse (at 220V, 240V)
	Rotary Switch	333-3001-00	OUTPUT POWER
	Relay	362-2202-00	for Power Supply
	Insulator Washer	318-1102-00	for SG-5T
	Carbon Film Resistor 75Ω ±5% 1/2W	RD142HA750J	R14, 15
	Carbon Film Resistor 1.1kΩ ±5% 1/2W	RD142HA112J	R7, 8
	Carbon Film Resistor 2.2kΩ ±5% 1/2W	RD142HA222J	R9, 10
	Carbon Film Resistor 1.8kΩ ±5% 1/2W	RD142HA182J	R3, 4
	Carbon Film Resistor 6.8kΩ ±5% 1/2W	RD142HA682J	R5, 6
	Carbon Film Resistor 15kΩ ±5% 1/2W	RD142HA153J	R1, 2
	Oxide Metal Film Resistor 1kΩ ± 2W	RS143DA102JG	R11, 12
	Cement Coated Wire Wound Resistor 3.3Ω ±5% 20W	RW984DG3ROJ	R13
	Electrolytic Capacitor 33μF 35WV	CE02WIV330	C7, 8
	Ceramic Capacitor 0.01μF +100%, -0% 50WV	CK45E2H103P	C3, 4, 15, 16
	Ceramic Capacitor 680pF ±10% 50WV	CK45B1H681K	C13, 14
	Mylar Film Capacitor 0.01μF ±20% 250WV	CQ93M2E103MUL	C6
	Mica Capacitor 200pF ±5% 100WV	CM93D2A201J	C9, 10
	Mica Capacitor 1500pF ±5% 100WV	CM93D2A152J	C11, 12
	Transistor Insulator	318-0101-00	for 2SD130
	Transistor Insulator	318-0001-00	for SG-5T
	Power Supply Cord	680-1201-00	
	Variable Resistor 200KΩ	573-1101-00	for LEVEL (L) (R)
	Rotary Switch	332-2001-00	for BAND PASS FILTER, INPUT
	Push button Switch	354-1201-00	for Sub Panel Opener
	Push button Switch	354-1002-00	for Power Switch

PARTS LIST

Ref. No.	Description	Part No.	Remarks
1	Top Plate	150-0002-02	for Upper Side
2	Shield Cover	230-0004-02	for Sub Chassis
3	Shield Cover (L)	231-0002-00	for Left Side POWER AMP
4	Shield Cover (R)	231-0003-00	for Right Side POWER AMP
5	Side Plate	151-0002-02	for Both Side
6	Frame Assembly (L)	112-0001-12	for Left Side
7	Frame Assembly (R)	112-0002-12	for Right Side
8	Frame A	112-1001-13	Frame Assembly (L): □ for Upper
9	Frame B	112-1002-13	Frame Assembly (L): Bottom □ for Bottom
10	Frame C	112-1003-04	Frame Assembly (L) (R): □ for Rear
11	Frame D	112-1004-13	Frame Assembly (R): Upper □ for Upper
12	Frame E	112-1005-13	Frame Assembly (R): Bottom □ for Bottom
13	Bottom Plate	155-0002-02	
14	Front Panel	131-0002-02	Front Panel Assembly:
15	Panel End Cap (R)	132-0002-00	Front Panel Assembly: □ for Right Side
16	Panel End Cap (L)	132-0001-00	Front Panel Assembly: □ for Left Side
17	Panel End Spacer	250-1001-14	Front Panel Assembly:
18	Panel Name Plate	180-1002-13	Front Panel Assembly:
19	Sub Panel	134-0002-12	Front Panel Assembly:
20	Push button Frame	113-0003-03	Front Panel Assembly:
21	Push button Frame	113-0002-04	for METER RANGE Front Panel Assembly:
22	Knob	381-2601-04	for POWER Switch
23	Knob	381-3001-04	for LEVER (R), (L), OUTPUT POWER
24	Push button	389-5001-04	for SPEAKER
25	Push button	389-1201-04	METER RANGE, POWER Switch
26	Knob	384-1101-04	for Sub Panel Magnet Opener
27	Power Meter	178-2001-00	for INPUT, BANDPASS FILTER
28	Rubber Foot	238-0001-04	
29	Frame Fixed Plate	244-0001-04	Frame Assembly (L) (R):
30	Catcher	272-0001-04	Front Panel Assembly: Catch for Sub Panel Magnet Opener
31	Meter Frame	113-0004-03	Front Panel Assembly:
35	Coil Spring	285-1001-04	Front Panel Assembly:
36	Ball Bearing	220-0301-00	Front Panel Assembly:
37	Nylon Washer	673-1031-50	Front Panel Assembly:
40	Binding Head B type Selftapping Screw	614-0306-02	3x6mm: Fixed for TOP, SIDE, BOTTOM, Plates
41	Pan Head B type Selftapping Screw	610-0314-01	Front Panel Assembly: 3x14mm Fixed for Panel End Cap Rear Side
42	Pan Head ISO Metric Screw	615-0312-01	Front Panel Assembly: 3x12mm Fixed for Panel End Cap Front Side
43	Binding Head ISO Metric Screw	600-0306-02	3x6mm: Fixed for Shield Cover with Hexa Head Boss
45	Binding Head B type Selftapping Screw	614-0310-00	3x10mm: Fixed for Front Panel Assembly
46	Shaft	203-5001-04	SPEAKERS, OUTPUT POWER

CIRCUIT DESCRIPTION

The bias current of a power amplifier must be stable under all operating conditions.

This is particularly so in the case of power amplifiers whose every stage is direct-coupled since instability in any one stage will adversely affect current flow in the final output stage. Good stability is ensured in this power amplifier with the following methods.

1. A fixed voltage is applied with a constant voltage power supply to the emitters of Q9, Q10, Q11 and Q12 that make up the first stage differential amplifier circuit. In addition silicon diodes D1, D2, D3 and D4 are inserted in the collector circuit to stabilize the current of the following stage for Q13 to Q15 and Q14 to Q16 where Darlington amplification is employed.
2. Heat compensation is provided to assure constant current drive to the final stage with a silicon varistor D5 (STV-3H which is mounted beneath the power transistor heat sink), a thermistor (TH1 connected to Q15 2SA762), and potentiometer VR2 that are all

employed between the collectors of Q15 and Q16. The bias current for the final stage is the sum total requirement of the triple push-pull circuit and is set at 50 – 100mA. Power consumption during no signal condition is limited to this small current drain and so creates hardly any heat. If the amplifier is operated continuously at an average power output of 20 watts, both sides of the upper panels should heat up to about 40 degrees centigrade (about 104 degrees fahr.). If the amplifier is operated continuously at full power to deliver a single frequency signal, it may heat up as high as 70 degrees centigrade (160 degrees fahr.). If only one side of this amplifier heats up, bias current adjustment should be made, as explained on the following page, after the heat compensating elements have first been checked and found in order. Bias current adjustment is also necessary when the Main Drive Assembly printed-circuit board or the power transistors are replaced.

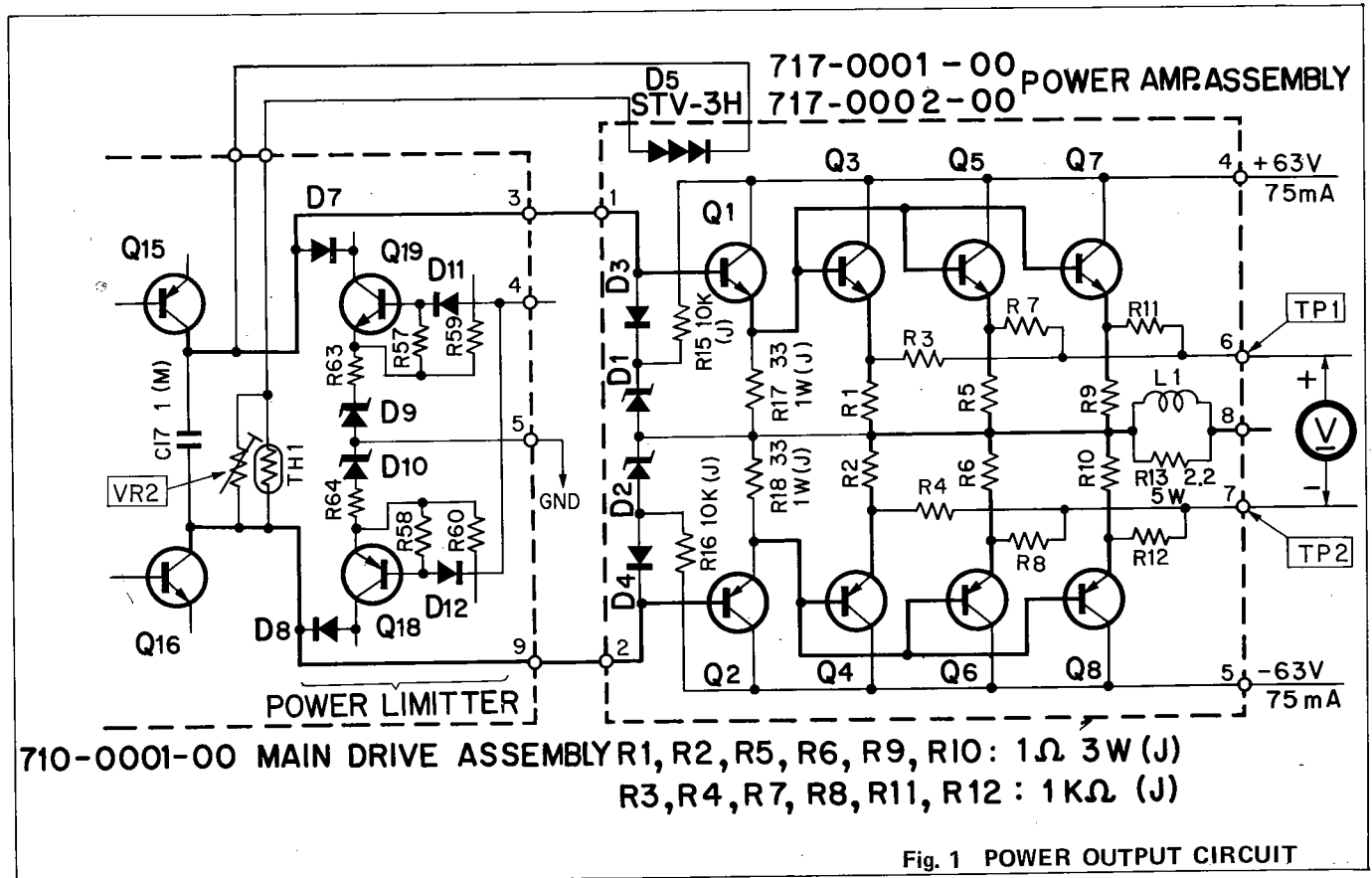

3. POWER LEVEL METER ADJUSTMENT

The power level meter on this amplifier is adjusted to indicate 0dB when the amplifier produces an output of 150W at 8 ohm load. It can be readjusted as follows if it is suspected that meter indications may be abnormal.

1. Connect an 8 ohm 150 watts dummy load and VTVM to an open speaker terminal.
2. Feed a 1 kHz signal, and set LEVEL control to maximum position to get an output of 150 watts (34.64V).
3. With METER RANGE switch set at "0dB" position, adjust VR1 (left channel) and VR2 (right channel) (see Fig. 2, top two adjustments) so that the Power Level meter indicates 0dB.

4. PROTECTION CIRCUIT ADJUSTMENT

The protection circuits in this power amplifier can be divided into ASO (Area of Safety Operation) detector circuit, abnormal load impedance detector circuit (for detection of speaker short circuit), abnormal output terminal DC voltage detector circuit, load short circuit relay switch control circuit and warning signal circuit. Of these, the abnormal load impedance detector circuit is adjustable, which should be done as follows whenever the printed-board circuit is replaced;

1. Turn the power switch OFF and connect a 1.5 ohm resistor to an unused SPEAKER terminal and set the SPEAKERS switch to that speaker terminal position.
2. Turn the Protection Assembly (VR1) (Fig. 2, upper side control) to full clockwise position.
3. Turn AC power switch ON. Confirm that the meter lamp starts to blink on and off continuously under this condition.
4. Back (VR1) slowly in counterclockwise direction until blinking stops.
5. Turn OFF AC power switch, and then change the 1.5 ohm resistor that is bridging the output terminal to a 1 ohm resistor.
6. Turn AC power switch ON again. Confirm that the meter lamp again starts to blink continuously.

Note: This adjustment ensures that the relay in the load circuit will open up to protect the power transistors if AC power is turned on when the load impedance is less than about 1 ohm (practically a near-short or short circuit).

MAIN DRIVE AMP. ASSEMBLY (710-0001-00)

PRINTED CIRCUIT BOARD

*Printed circuit board as seen from the reverse side.

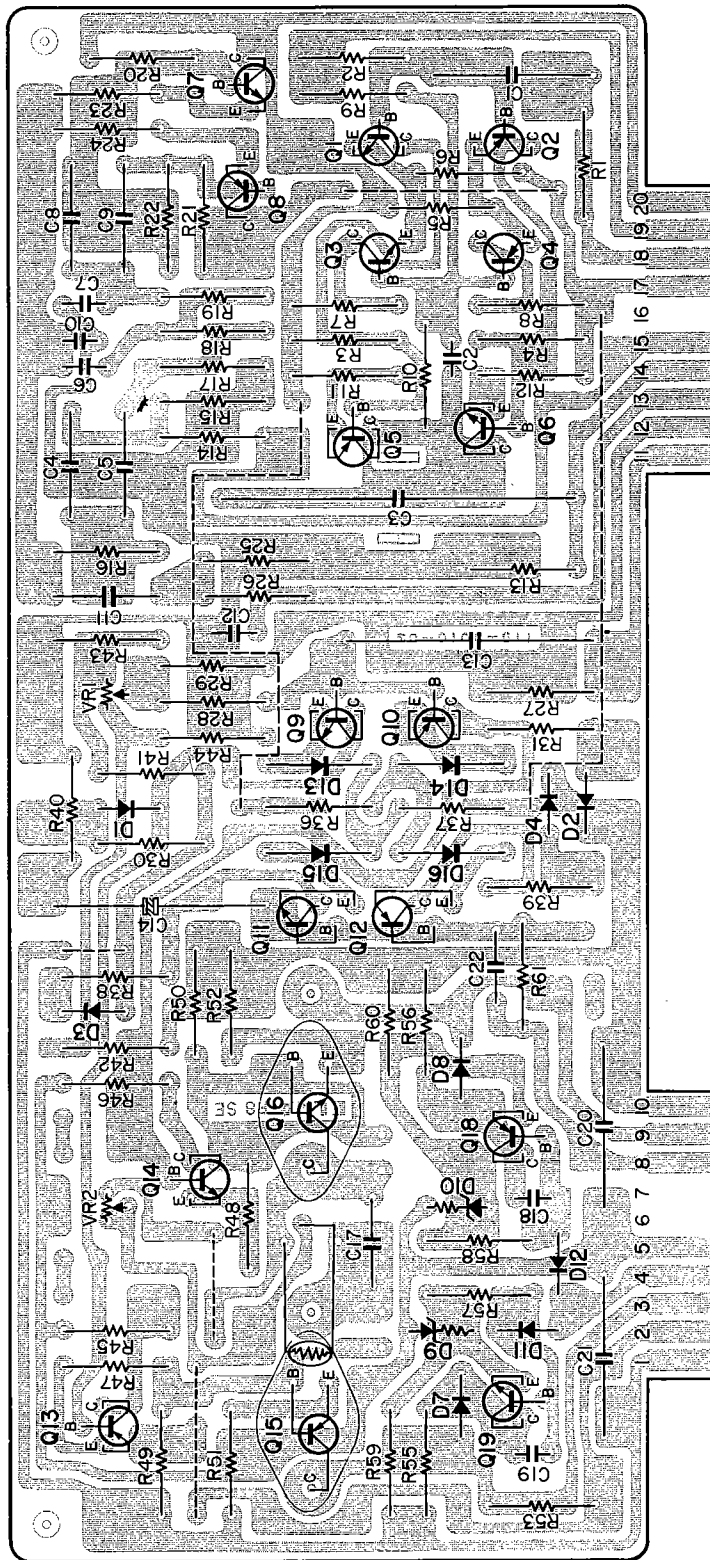

1. BIAS CURRENT ADJUSTMENT

This amplifier is equipped with testing points TP1 and TP2 as shown in Fig. 2 for bias current adjustment. This current is calculated from the voltage that is measured across these test points, as follows:

1. After the amplifier has been serviced and restored to normal, connect speakers or dummy loads to it. If there is an input signal, set the LEVEL controls to MIN position.
2. Connect a volt-ohm-multitester or voltmeter with an interior impedance of more than $100K\Omega/V$ and full scale range of 0.3V across TP1 (+) and TP2 (-).
3. Adjust Main Drive Assembly **VR2** (see Fig. 2) so that the meter indicates 0.07V which represents a current flow of about 100mA. (Turning VR2 in counterclockwise direction increases the current flow.)
4. Adjust **VR2** for the opposite channel in the same manner.
5. Feed signal into the amplifier to confirm that is operating normally.
6. Let amplifier warm up thoroughly with a one watt output for approximately 15 minutes.
7. Now cut the input signal, connect the voltmeter again to the test points and adjust VR2 so that the meter indicates 0.05V which represents about 75mA.

Note 1: The Power Level Meter will deflect even under no signal conditions if the center voltage is not correctly at "0" potential. In such a case, switch off the load (set SPEAKERS switch to OFF position) and adjust the center voltage first, as explained in the following paragraph, before attempting to make this bias adjustment.

Note 2: Bias current above is calculated as follows:
 $I = V/R$
where V is the voltmeter reading,
and R is 0.67 ohms (the resistance of the power transistor emitter resistor).

2. VOLTAGE ADJUSTMENT

The output terminals of a direct coupled, positive-negative dual power supply type amplifier should be at "0" electric potential in terms of DC. This voltage can be kept to within ± 200 mV with an ordinary circuit design, which does not employ the aid of a voltage adjustment circuit. However, this power amplifier is equipped with such an adjustment circuit to ensure further stability.

Its adjustment is made as follows.

1. Connect the same type of voltmeter that was used for bias adjustment across unloaded speaker terminal and set the SPEAKERS switch to the corresponding position.
2. Switch power ON and, under no signal conditions adjust **VR1** of the Main Drive Assembly (see Fig. 2) so that the meter indicates 0 volts.

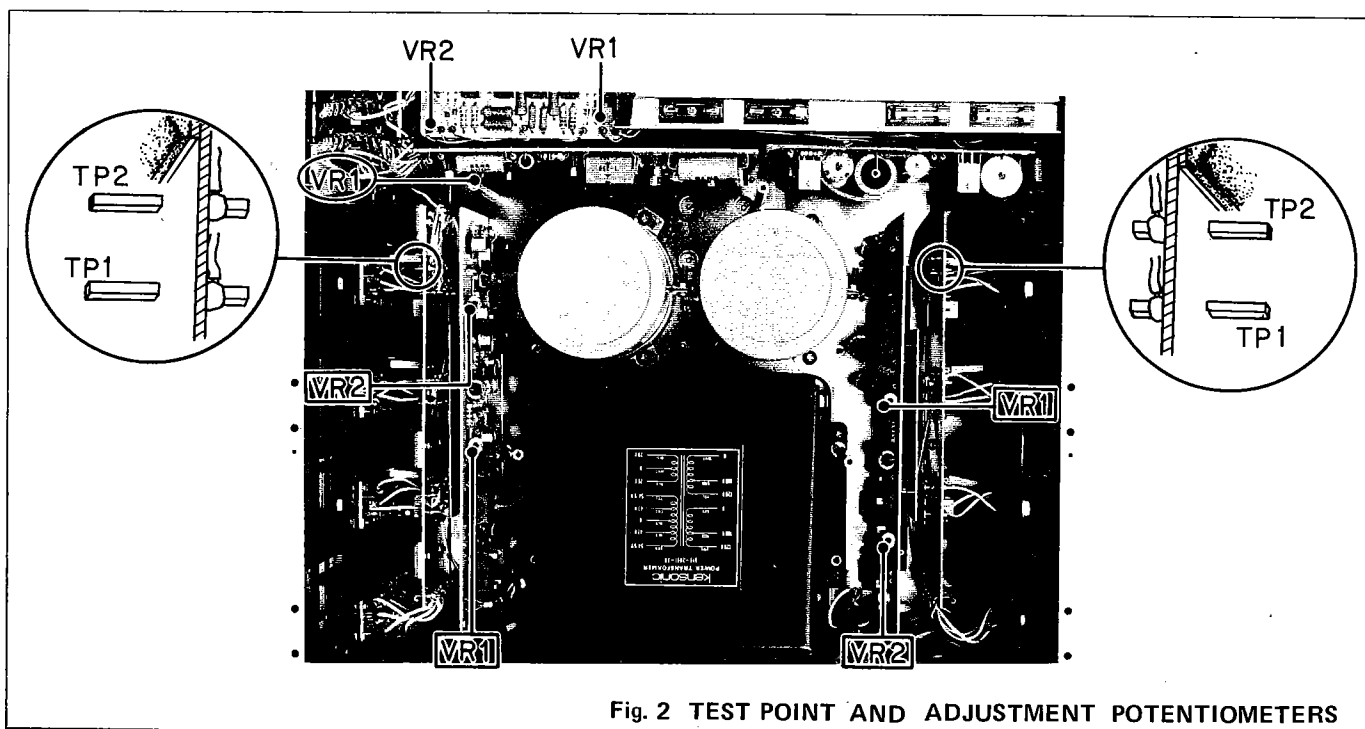

Fig. 2 TEST POINT AND ADJUSTMENT POTENTIOMETERS

CIRCUIT DESCRIPTION

The bias current of a power amplifier must be stable under all operating conditions.

This is particularly so in the case of power amplifiers whose every stage is direct-coupled since instability in any one stage will adversely affect current flow in the final output stage. Good stability is ensured in this power amplifier with the following methods.

1. A fixed voltage is applied with a constant voltage power supply to the emitters of Q9, Q10, Q11 and Q12 that make up the first stage differential amplifier circuit. In addition silicon diodes D1, D2, D3 and D4 are inserted in the collector circuit to stabilize the current of the following stage for Q13 to Q15 and Q14 to Q16 where Darlington amplification is employed.
2. Heat compensation is provided to assure constant current drive to the final stage with a silicon varistor D5 (STV-3H which is mounted beneath the power transistor heat sink), a thermistor (TH1 connected to Q15 2SA762), and potentiometer VR2 that are all

employed between the collectors of Q15 and Q16. The bias current for the final stage is the sum total requirement of the triple push-pull circuit and is set at 50 – 100mA. Power consumption during no signal condition is limited to this small current drain and so creates hardly any heat. If the amplifier is operated continuously at an average power output of 20 watts, both sides of the upper panels should heat up to about 40 degrees centigrade (about 104 degrees fahr.). If the amplifier is operated continuously at full power to deliver a single frequency signal, it may heat up as high as 70 degrees centigrade (160 degrees fahr.). If only one side of this amplifier heats up, bias current adjustment should be made, as explained on the following page, after the heat compensating elements have first been checked and found in order. Bias current adjustment is also necessary when the Main Drive Assembly printed-circuit board or the power transistors are replaced.

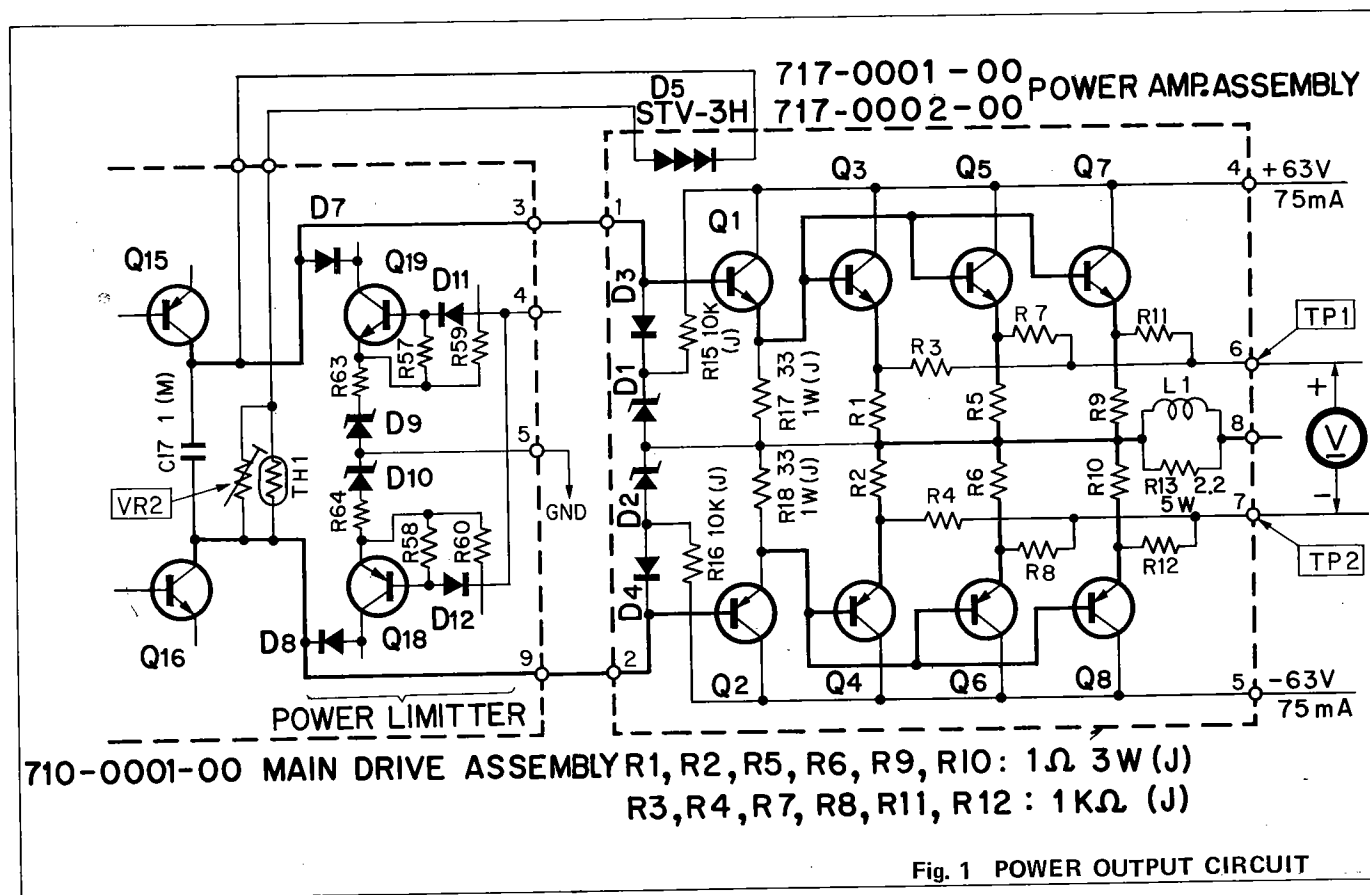

PARTS LIST

Ref. No.	Description	Part No.	Remarks
D11, 12	Heatsink	240-2001-00	for Q18, 19
D1, 2, 3, 4, 13, 14,	Transistor Spacer	250-0001-00	for Q9, 10, 11, 12, 13, 18, 19
15, 16	Silicon Diode	1S1553	
D7, 8	Silicon Diode	1S1555	
D9, 10	Silicon Diode	1S2091BL	
Q10, 12	Zener Diode	XZ-060	
Q13, 18	Transistor PNP	2SA497Y	
Q15	Transistor PNP	2SA497O	
Q8	Transistor PNP	2SA762-2-2	
Q2, 4, 5	Transistor PNP	2SA776GR	
Q9, 11	Transistor PNP	2SA776AGR	
Q14, 19	Transistor PNP	2SA497Y	
Q7	Transistor NPN	2SC497O	
Q1, 3, 6	Transistor NPN	2SC1416GR	
Q16	Transistor NPN	2SC1416AGR	
VR2	Potentiometer 200Ω	2SC1431-2-2	
VR1	Potentiometer 5kΩ	581-0221-00	
R47, 48, 63, 64	Carbon Film Resistor 10Ω ±5% 1/2W	581-0532-00	
R45, 46	Carbon Film Resistor 100Ω ±5% 1/2W	RD142HA100J	
R23, 24	Carbon Film Resistor 220Ω ±5% 1/2W	RD142HA101J	
R14	Carbon Film Resistor 390Ω ±5% 1/2W	RD142HA221J	
R11, 12, 49, 50,	Carbon Film Resistor 1kΩ ±5% 1/2W	RD142HA391J	
43, 44, 29	Carbon Film Resistor 1.5kΩ ±5% 1/2W	RD142HA102J	
R30, 31, 38, 39	Carbon Film Resistor 3.3kΩ ±5% 1/2W	RD142HA152J	
R1	Carbon Film Resistor 6.2kΩ ±5% 1/2W	RD142HA332J	
R9	Carbon Film Resistor 5.6kΩ ±5% 1/2W	RD142HA622J	
R18, 19, 26	Carbon Film Resistor 8.2kΩ ±5% 1/2W	RD142HA562J	
R40	Carbon Film Resistor 9.1kΩ ±5% 1/2W	RD142HA822J	
R36, 37	Carbon Film Resistor 22kΩ ±5% 1/2W	RD142HA912J	
R16, 55, 56, 59,	Carbon Film Resistor 33kΩ ±5% 1/2W	RD142HA223J	
60	Carbon Film Resistor 47kΩ ±5% 1/2W	RD142HA333J	
R10, 41, 42	Carbon Film Resistor 56kΩ ±5% 1/2W	RD142HA473J	
R22	Carbon Film Resistor 100kΩ ±5% 1/2W	RD142HA563J	
R28, 61	Carbon Film Resistor 150kΩ ±5% 1/2W	RD142HA104J	
R57, 58	Carbon Film Resistor 180kΩ ±5% 1/2W	RD142HA154J	
R17	Carbon Film Resistor 620kΩ ±5% 1/2W	RD142HA184J	
R25	Carbon Film Resistor 1MΩ ±5% 1/2W	RD142HA624J	
R20, 21	Metal Film Resistor 1kΩ ±5% 1/2W	RD142HA105J	
R13, 15, 27	Metal Film Resistor 62kΩ ±5% 1/2W	RN142HA113JO	
R3, 4, 7, 8	Metal Film Resistor 270kΩ ±5% 1/2W	RN142HA623JO	
R5, 6	Oxide Metal Film Resistor 100Ω ±5% 1W	RN142HA274JO	
R2	Bipolar Electrolytic Capacitor 47μF 16WV	RS143AA101JG	
R51, 52	Ceramic Capacitor 47pF ±10% 50WV	CE02D1C470(BP)	
C14	Ceramic Capacitor 1pF ±0.25% 500WV	CC45SL1H470K	
C10	Mica Capacitor 10pF ±5% 100WV	CC45SL2H010C	
C18, 19	Mica Capacitor 470pF ±5% 100WV	CM93D2A100J	
C2, 22	Mylar Film Capacitor 0.001μF ±5% 50WV	CM93D2A471J	
C7	Mylar Film Capacitor 0.0022μF ±5% 50WV	CQ93M1H102J	
C12	Mylar Film Capacitor 0.22μF ±5% 50WV	CQ93M1H222J	
C6	Metallized Film Capacitor 0.1μF ±20% 250WV	CQ93M1H224J	
C4, 5, 8, 9, 11	Metallized Film Capacitor 2.2μF ±20% 250WV	CQ93M2E104M	
C17, 20, 21	Metallized Film Capacitor 4.7μF ±20% 250WV	CQ91M2E225M	
C13	Metallized Film Capacitor 1μF ±20% 250WV	CQ91M2E457M	
C3	Capacitor 1μF ±20% 250WV	CQ93M2E105M	
C1	Capacitor	639-2031-01	for 2SA762-22, 2SC1431-2-2
TH1	Toothed Washer	5TP-31L	
	Thermistor		

PROTECTION CIRCUIT ASSEMBLY (720-0001-00)

PRINTED CIRCUIT BOARD

*Printed circuit board as seen from the reverse side.

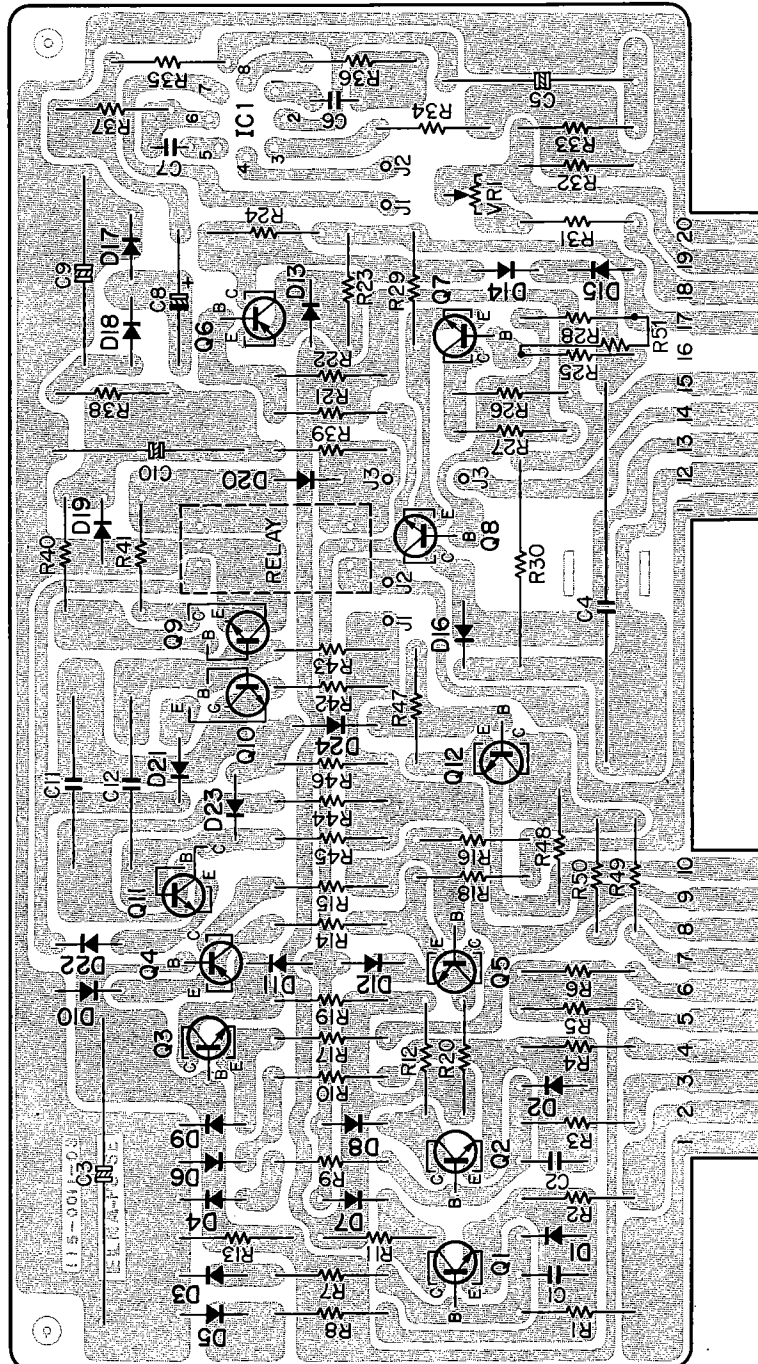

PARTS LIST

Ref. No.	Description	Part No.	Remarks
Relay	Heatsink	240-2001-00	for Q12
D3, 4, 5, 6, 11, 12, 15	Reed Relay	363-2201-00	
D1, 2, 9, 10, 13, 14, 17, 18, 19, 20, 21, 22, 23, 24	Silicon Diode	1S1553	
D7, 8, 16	Silicon Diode	1S1555	
Q6	Silicon Diode	1S2091-BL	
Q4	Transistor PNP	2SA497 RO or Y	
Q12	Transistor PNP	2SA776GR	
Q8	Transistor NPN	2SA485Y	
Q7	Transistor NPN	2SC497O or Y	
Q9, 10, 11	Transistor NPN	2SC1416BL	
Q1, 2, 3, 5	Transistor NPN	2SC1416GR or BL	
IC1	Transistor NPN	2SC1452G or B	
VR1	IC	TA7502M	
R18	Potentiometer 47kΩ B	581-0541-00	
R29	Carbon Film Resistor 10Ω ±5% 1/2W	RD142HA100J	
R41	Carbon Film Resistor 22Ω ±5% 1/2W	RD142HA220J	
R37	Carbon Film Resistor 24Ω ±5% 1/2W	RD142HA240J	
R33	Carbon Film Resistor 33Ω ±5% 1/2W	RD142HA330J	
R40	Carbon Film Resistor 560Ω ±5% 1/2W	RD142HA561J	
R46	Carbon Film Resistor 1kΩ ±5% 1/2W	RD142HA102J	
R36	Carbon Film Resistor 1.2kΩ ±5% 1/2W	RD142HA122J	
R14, 16, 17	Carbon Film Resistor 1.5kΩ ±5% 1/2W	RD142HA152J	
R22	Carbon Film Resistor 2.2kΩ ±5% 1/2W	RD142HA222J	
R26	Carbon Film Resistor 3.3kΩ ±5% 1/2W	RD142HA332J	
R13, 15, 31, 38	Carbon Film Resistor 5.6kΩ ±5% 1/2W	RD142HA562J	
R5, 6	Carbon Film Resistor 10kΩ ±5% 1/2W	RD142HA103J	
R7, 8, 9, 10, 11, 12, 19, 20, 21, 22, 23, 24, 27, 28, 42, 45, 47	Carbon Film Resistor 7.5kΩ ±5% 1/2W	RD142HA752J	
R39	Carbon Film Resistor 22kΩ ±5% 1/2W	RD142HA223J	
R34, 35	Carbon Film Resistor 100kΩ ±5% 1/2W	RD142HA104J	
R43, 44	Carbon Film Resistor 560kΩ ±5% 1/2W	RD142HA564J	
R25, 51	Carbon Film Resistor 330kΩ ±5% 1/2W	RD142HA334J	
R49, 50	Carbon Film Resistor 470kΩ ±5% 1/2W	RD142HA474J	
R32	Metal Film Resistor 5.6Ω ±5% 1W	RN143AA5R6JX	
R48	Metal Film Resistor 10Ω ±5% 1W	RN143AA100J	
R1, 2, 3, 4	Oxide Metal Film Resistor 100Ω ±5% 1W	RS143AA101JG	
R30	Oxide Metal Film Resistor 1kΩ ±5% 1W	RS143AA102JG	
C8	Oxide Metal Film Resistor 470Ω ±5% 3.16W	RS143FA471JG	
C3	Bipolar Electrolytic Capacitor 3.3μF 35WV	CE02W1V3R3	
C5, 10	Bipolar Electrolytic Capacitor 220μF 10WV	CE02D1A221(BP)	
C9	Bipolar Electrolytic Capacitor 10μF 25WV	CE02D1E100(BP)	
C7	Bipolar Electrolytic Capacitor 3.3μF 50WV	CE02D1H3R3(BP)	
C6	Ceramic Capacitor 220pF ±10% 50WV	CC45SL1H221K	
C1, 2	Mylar Film Capacitor 0.0047μF ±20% 50WV	CQ93M1H472M	
C4	Mylar Film Capacitor 0.047μF ±5% 50WV	CQ93M1H473J	
C11, 12	Metallized Film Capacitor 3.3μF ±20% 250WV	CQ91M2E335M	
	Metallized Film Capacitor 1μF ±20% 250WV	CQ93M2E105M	

POWER SUPPLY ASSEMBLY (719-0002-00)

PRINTED CIRCUIT BOARD

*Printed circuit board as seen from the reverse side.

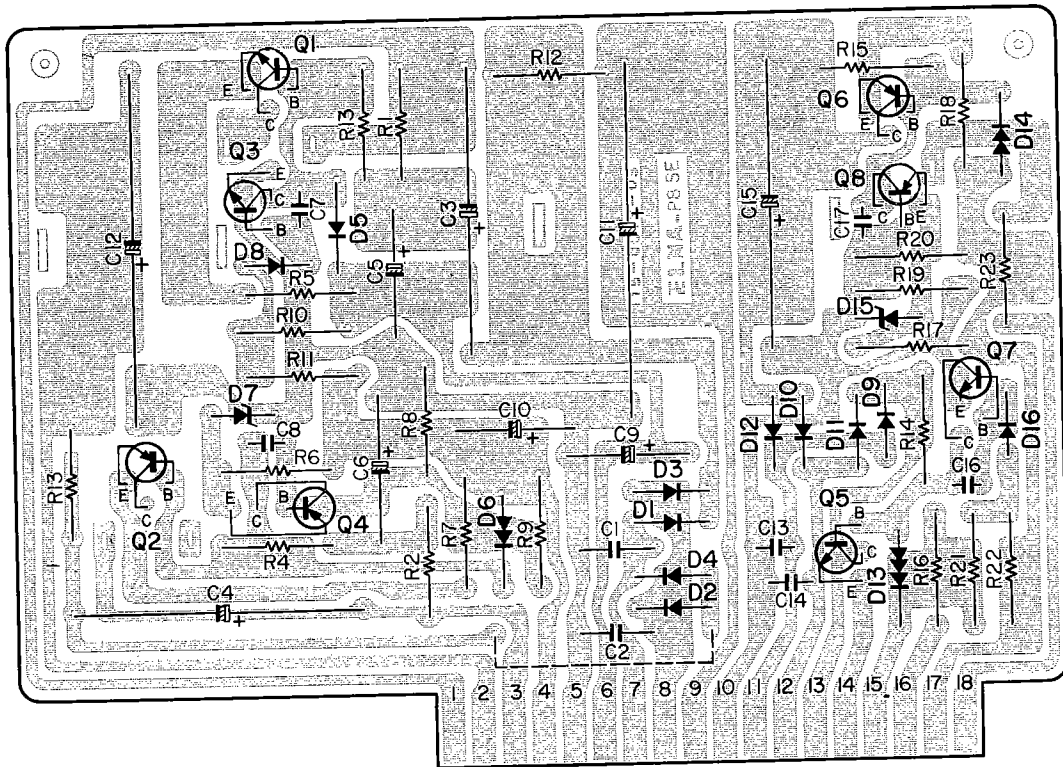

PARTS LIST

Ref. No.	Description	Part No.	Remarks
	Heatsink	240-1002-04	Q1, 2, 6
D9, 10, 11, 12	Silicon Diode	1BZ061	
D1, 2, 3, 4	Silicon Diode	1GZ061	
D8, 16	Silicon Diode	1S1555	
D5, 6, 14	Silicon Varistor	SV-02	
D13	Silicon Varistor	SV-03	
D7, 15	Zener Diode	XZ-060	
Q2	Transistor PNP	2SA4890 or Y	
Q4	Transistor PNP	2SA6610 or Y	
Q8	Transistor PNP	2SA776GR or BL	
Q6	Transistor PNP	2SB4350 or Y	
Q1	Transistor NPN	2SC7890 or Y	
Q3, 5	Transistor NPN	2SC11660 or Y	
Q7	Transistor NPN	2SC1416GR or BL	
R8, 10, 19, 21	Carbon Film Resistor 10kΩ ±2% 1/2W	RD142HA1002G	
R11	Carbon Film Resistor 11kΩ ±2% 1/2W	RD142HA1102G	
R22	Carbon Film Resistor 11.3kΩ ±2% 1/2W	RD142HA1132G	
R20	Carbon Film Resistor 14.0kΩ ±2% 1/2W	RD142HA1402G	
R9	Carbon Film Resistor 28.0kΩ ±2% 1/2W	RD142HA2802G	
R18	Carbon Film Resistor 15Ω ±5% 1/2W	RD142HA150J	
R5, 7	Carbon Film Resistor 20Ω ±5% 1/2W	RD142HA200J	
R23	Carbon Film Resistor 33Ω ±5% 1/2W	RD142HA330J	
R14	Carbon Film Resistor 2.2kΩ ±5% 1/2W	RD142HA222J	
R17	Carbon Film Resistor 1.2kΩ ±5% 1/2W	RD142HA122J	
R6	Carbon Film Resistor 4.7kΩ ±5% 1/2W	RD142HA472J	
R15	Carbon Film Resistor 3.3kΩ ±5% 1/2W	RD142HA332J	
R1, 2, 3, 4	Carbon Film Resistor 5.6kΩ ±5% 1/2W	RD142HA562J	
R16	Metal Film Resistor 0.24Ω ±5% 1W	RN143AAR24JX	
R12, 13	Oxide Metal Film Resistor 100Ω ±5% 1W	RS143AA101J	
C3, 4	Electrolytic Capacitor 1000μF 10WV	CE02W1A102	
C9, 10	Electrolytic Capacitor 10μF 35WV	CE02W1V100	
C15	Electrolytic Capacitor 470μF 35WV	CE02W1V471	
C5	Electrolytic Capacitor 4.7μF 50WV	CE02W1H4R7	
C6	Electrolytic Capacitor 10μF 50WV	CE02W1H100	

HOW TO REPLACE POWER TRANSISTORS

POWER TRANSISTOR REPLACEMENT SHOULD BE DONE WITH THE FOLLOWING PROCEDURE.

1. Remove the screws which hold the side cabinet plate and remove the plate.
2. Remove the screw which hold power transistor and remove the defective power transistor.
3. Spread silicon grease on both fuses of power transistor insulator before replacement.
4. Fix the power transistor firmly with the screws on the heat sink.
5. Check the power transistor is not in contact with the heat sink.
6. Fix side cabinet plate with the screws.

*The power transistor used in the P-300 is singled out for high V_{ceo}.

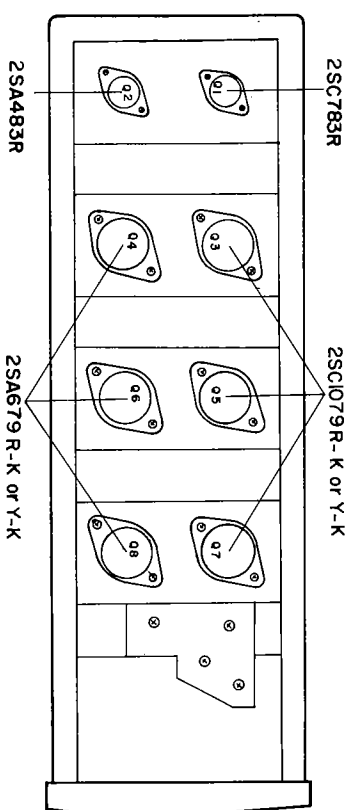

Ref. No.	Description	Part No.	Remarks
C11, 12 C7, 8, 13, 14, 16, 17	Electrolytic Capacitor 330 μ F 80WV Ceramic Capacitor 0.01 μ F +80%, -20% Ceramic Capacitor 0.01 μ F +100%, -0% 50WV 500WV	CE02W1K331 CK45F1H103Z CK45F2H103P	
C1, 2			

POWER AMP. ASSEMBLY (717-0001-00, 717-0002-00)

PARTS LIST

Ref. No.	Description	Part No.	Remarks
D3, 4	Transistor Socket Transistor Socket Silicon Diode	300-0001-00 300-0101-00 1S2091-BL	for 2SA697R, 2SC1079R for 2SA483, 2SC783R
D1, 2	Zener Diode	CZ-057	
O4, 6, 8	Transistor PNP	2SA679R-K or Y-K	
O1	Transistor NPN	2SC783-R	
O2	Transistor PNP	2SA483R	
O3, 5, 7	Transistor NPN	2SC1079R-K or Y-K	
D5	Silicon Varistor	STV-3H	
L1	Choke Coil 2 μ H	706-0001-00	
R3, 4, 7, 8, 11, 12	Carbon Film Resistor 1k Ω	RD142HA102J	
R15, 16	Carbon Film Resistor 10k Ω	RD142HA103J	
R17, 18	Oxide metal Film Resistor	RS143AA330JG	
R1, 2, 5, 6, 9, 10	Cement Coated Metal Plate Resistor 33 Ω	RW993F1R0J	
R13	Cement Coated Wire Wound Resistor 1 Ω	RW993H2R2J	
R14	Cement Coated Wire Wound Resistor 2.2 Ω	RW983H100J	
C5	Metalized Film Capacitor 0.1 μ F \pm 20% 250WV	CO93M2E104M	
C6	Ceramic Capacitor 0.01 μ F 500WV Transistor Insulator	CK45E2H103P 318-0001-00 318-0101-00	for 2SC1079, 2SA679 for 2SA483, 2SC783

PUSH BUTTON SWITCH ASSEMBLY (716-0004-00)

PARTS LIST

Ref. No.	Description	Part No.	Remarks
D1, 2, 3, 4, 5, 6, 7, 8	Push button Switch	354-4001-00	
VR1, 2	Germanium Diode Potentiometer	1N60 580-0531-00	
R1, 2	Carbon Film Resistor 200 Ω	RD142HA201J	
R7, 8	Carbon Film Resistor 220 Ω	RD142HA221J	
R11, 12	Carbon Film Resistor 2.2k Ω	RD142HA222J	
R9, 10	Oxide Metal Film Resistor	RS143AA301JG	
R5, 6	Oxide Metal Film Resistor 330 Ω \pm 5% 1W	RS143AA202JG	
R3, 4	Oxide Metal Film Resistor 2k Ω \pm 5% 1W	RS143DA681JG	
	Oxide Metal Film Resistor 680 Ω \pm 5% 2W	CE02W1V100	
C1, 2	Electrolytic Capacitor 10 μ F 35WV		

RESISTOR COLOR CODE

4 COLOR CODE RESISTOR

COLOR (Meaning)	1st (Value)	2nd (Value)	3rd (Multiplier)	4th (Tolerance)	Remarks
Black	0	0	10 ⁰		
Brown	1	1	10 ¹	± 1%	
Red	2	2	10 ²	± 2%	
Orange	3	3	10 ³		
Yellow	4	4	10 ⁴		
Green	5	5	10 ⁵		
Blue	6	6	10 ⁶		
Purple	7	7	10 ⁷		
Grey	8	8	10 ⁸		
White	9	9	10 ⁹		
Gold	—	—	10 ⁻¹	± 5%	
Silver	—	—	10 ⁻²	± 10%	
Non-Color	—	—	—	± 20%	

5 COLOR CODE RESISTOR

COLOR (Meaning)	1st (Value)	2nd (Value)	3rd (Value)	4th (Multiplier)	5th (Tolerance)	Remarks
Black	0	0	0	10 ⁰		
Brown	1	1	1	10 ¹	± 1%	
Red	2	2	2	10 ²	± 2%	
Orange	3	3	3	10 ³		
Yellow	4	4	4	10 ⁴		
Green	5	5	5	10 ⁵		
Blue	6	6	6	10 ⁶		
Purple	7	7	7	10 ⁷		
Grey	8	8	8	10 ⁸		
White	9	9	9	10 ⁹		
Gold	—	—	—	10 ⁻¹	± 5%	
Silver	—	—	—	10 ⁻²	± 10%	
Non-Color	—	—	—	—	± 20%	

EXAMPLE

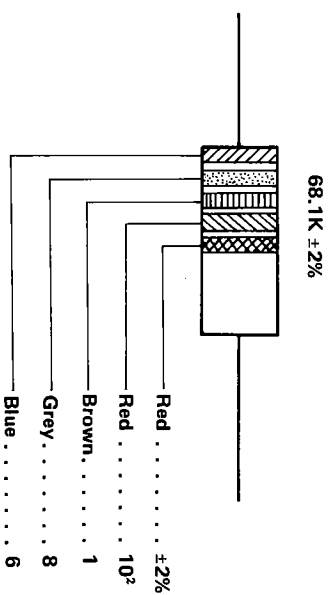

TRANSISTOR LEADS

MAIN DRIVE AMP. ASSEMBLY

REF. NO.	DESCRIPTION	PICTURE 1
Q ₁ Q ₃ Q ₆ Q ₇	2SC1416 GR	B
Q ₂ Q ₄ Q ₅ Q ₈	2SA776 GR	
Q ₁₀ Q ₁₂	2SA497 Y	D
Q ₉ Q ₁₁	2SC497 Y	
Q ₁₃ Q ₁₈	2SA497 O	
Q ₁₄ Q ₁₉	2SC497 O	
Q ₁₅	2SA 762-2-2	C
Q ₁₆	2SC1431-2-2	

POWER AMP. ASSEMBLY

REF. NO.	DESCRIPTION	PICTURE 1
Q ₁	2SC783 R	C
Q ₂	2SA483 R	
Q ₃ Q ₅ Q ₇	2SC1079 R-K or Y-K	
Q ₄ Q ₆ Q ₈	2SA679 R-K or Y-K	

PROTECTION CIRCUIT ASSEMBLY

REF. NO.	DESCRIPTION	PICTURE 1
Q ₁ Q ₂ Q ₃ Q ₅	2SC1452 G or R	F
Q ₆	2SA497 O or Y	D
Q ₈	2SC497 O or Y	
Q ₄	2SA776 GR	B
Q ₇	2SC1416 BL	
Q ₉ Q ₁₀ Q ₁₁	2SC1416 GR or BL	

MAIN CHASSIS

REF. NO.	DESCRIPTION	PICTURE 1
Q ₁	2SD130	C

Use of transistors other than specified will adversely affect performance and should be avoided.

POWER SUPPLY ASSEMBLY

REF. NO.	DESCRIPTION	PICTURE 1
Q ₁	2SC789 O or Y	A
Q ₂	2SA489 O or Y	
Q ₆	2SB435 O or Y	E
Q ₃ Q ₅	2SC1166 O or Y	
Q ₄	2SA661 O or Y	
Q ₇	2SC1416 BR or BL	
Q ₈	2SA776 BR or BL	B

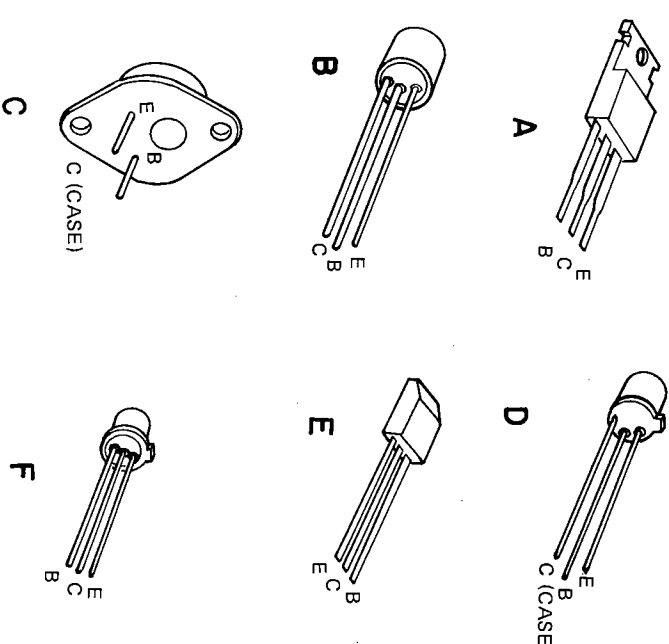

THE MARK OF CAPACITOR AND RESISTORS ON THE SCHEMATIC DIAGRAM

- : CERAMIC CAPACITORS
 - ⊖: MICA CAPACITORS
 - ⊗: TANTALUM SOLID CAPACITORS
 - : METALLIZED FILM CAPACITOR
 - ⊕: POLYSTYRENE FILM CAPACITORS
 - ⊙: MYLAR FILM CAPACITORS
 - : METAL FILM RESISTORS
 - : OXED METAL FILM RESISTORS
 - ⊠: CEMENT COATED WIRE WOUND RESISTORS
 - ⊞: CEMENT COATED METAL PLATE RESISTORS
- Unless other wise specified: Capacitors are ELECTROLYT-IC Types: Resistors are CARBON FILM Types, 1/2 watt, and ±5% tolerance.

Indicated values of parts in the schematic diagram may be changed in case of performance improvement.

SCHEMATIC DIAGRAM

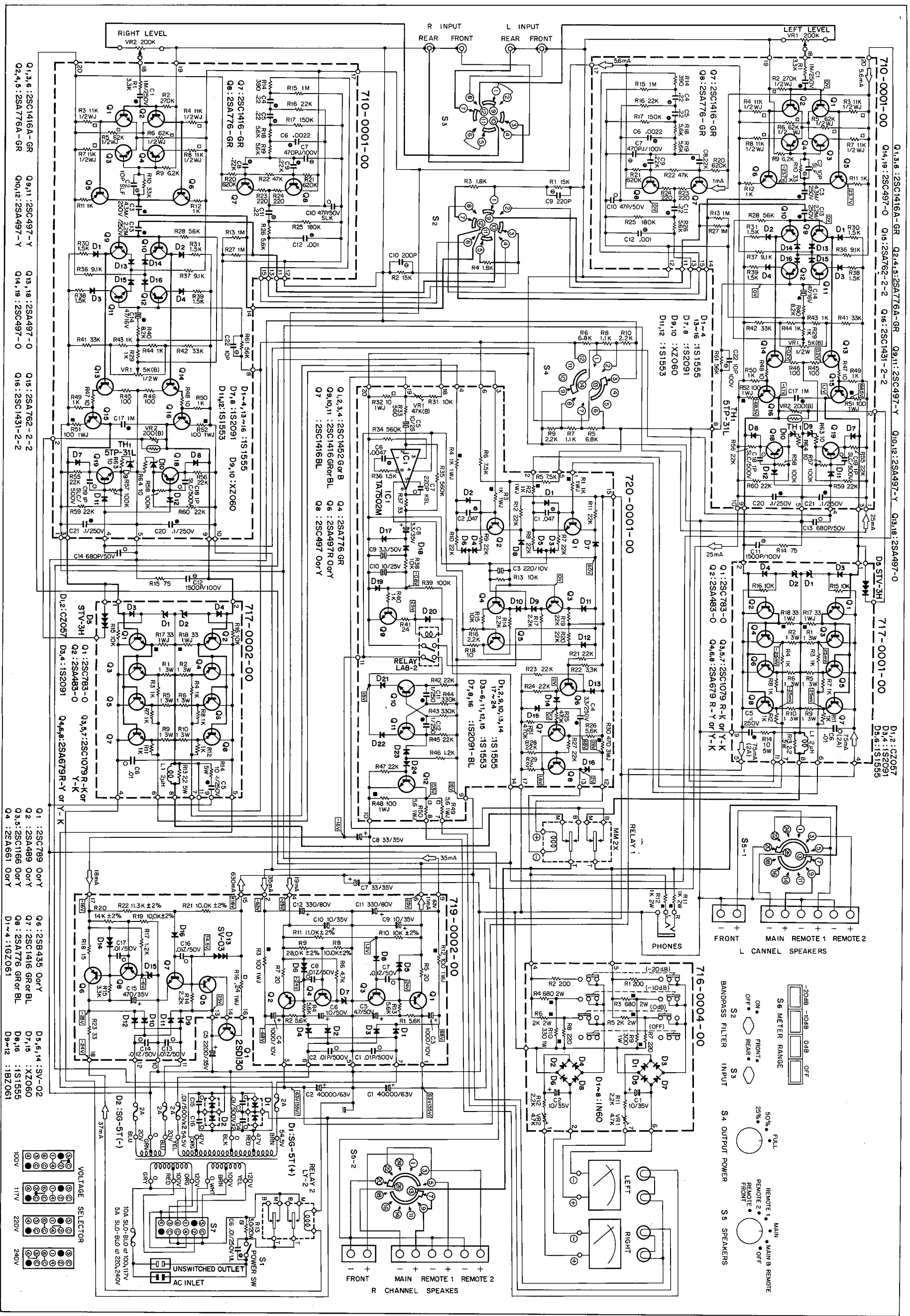

SPECIFICATIONS

PERFORMANCE GUARANTEE:

Products of Kenosonic guarantee specifications stated.

POWER OUTPUT:

200 RMS Watts continuous per channel into 4 ohms.
150 RMS Watts continuous per channel into 8 ohms.
75 RMS Watts continuous per channel into 16 ohms.
(with both channels operating simultaneously at any frequency from 20 Hz to 20,000 Hz).

HARMONIC DISTORTION:

will not exceed 0.1% at rated power output.
will not exceed 0.05% at half of rated output.
will not exceed 0.1% at 50 mW.
(at any frequency from 20 Hz to 20,000 Hz).

INTERMODULATION DISTORTION:

will not exceed 0.1% at rated output for any combination of frequencies between 20 Hz and 20,000 Hz.

FREQUENCY RESPONSE:

20 Hz to 20,000 Hz +0, -0.2 dB at rated power output.

DAMPING FACTOR:

40 at 4 ohms load.
20 at 8 ohms load.
(at any frequency from 20 Hz to 20,000 Hz).

INPUT SENSITIVITY AND IMPEDANCE:

1.0 volts, 100 K ohms, for rated output at the maximum level control.

HUM AND NOISE:

100 dB below rated output.

POWER LEVEL METER:

Meter is calibrated to read 0 dB when amplifier produces 150 watts (8 ohms load).

METER RANGE switch is provided to increase meter sensitivity by 10 dB or 20 dB.

OUTPUT LOAD IMPEDANCE:

4, 8 and 16 ohms.

AUDIO BANDPASS FILTER:

Cutoff frequency: LOW, 17 Hz, 18 dB/oct, HIGH, 24,000 Hz 18 dB/oct.

POWER LIMITER:

Full power output, 50% rated power output and 25% rated power output with front panel switching

POWER REQUIREMENT:

Voltage selector for 100V, 117V, 220V, 240V 50/60 Hz operation.

Consumption: 100 Watts at zero signal output.
510 Watts at rated output (8 ohms load).

SEMICONDUCTOR COMPLEMENT:

73 Transistors, 1 IC, 88 Diodes, 2 Thermistors.

DIMENSIONS:

17 1/2 inches (445 mm) wide, by 6 inches (152 mm) high, 14 inches (355 mm) deep.

WEIGHT:

55 pounds (25 kg.) net, 64.5 pounds (29.3 kg.) in shipping carton.

 Accuphase

KENSONIC LABORATORY INC.
2124-6 MOTOISHOKAWA-CHO,
MIDORIKU, YOKOHAMA, JAPAN