

INSTRUCTION MANUAL
FOR
AIRCRAFT RECEIVER EQUIPMENT



Type RA-1B, RA-1I and RA-1J

BRITISH AIRWAYS
BRISTOL.

ref 17/2
RADIO SERVICE SUPTS. OFFICE.

BENDIX RADIO CORPORATION
SUBSIDIARY OF BENDIX AVIATION CORPORATION
U. S. A.

INSTRUCTION BOOK
for
MODELS RA-1B, RA-II AND RA-1J
AIRCRAFT RECEIVER EQUIPMENT

WARRANTY

The Bendix Radio Corporation warrants each equipment manufactured by it to be free of defects in material and workmanship under the normal use and service for which the equipments are intended. The obligation of the Corporation is limited to making good at its factory any part or parts thereof, which shall, within ninety (90) days after delivery to the original purchaser, be returned to the Corporation with transportation charges prepaid, and which its examination shall disclose, to its satisfaction, to have been thus defective. The Corporation makes no warranty of vacuum tubes or their operation; further, this warranty does not apply to any defect in materials that cannot be discovered by ordinary factory inspection. This warranty is in lieu of all other warranties expressed or implied, and does not apply to any products of the Corporation which have been repaired or altered, or have been subject to misuse or abuse. The Corporation is not liable for any damage or personal injury resulting directly or indirectly from the design, material, workmanship, or installation of any of its products, and neither assumes nor authorizes any other person to assume for it any other liability in connection with the sale of its equipments.

BENDIX RADIO CORPORATION

Baltimore, Maryland

U. S. A.

TABLE OF CONTENTS

	<i>Page</i>
1. INTRODUCTION	
1-1. Function	1
1-2. Composition	1
1-3. Electrical Characteristics	2
1-4. Additional Equipment Required	4
1-5. Antenna Requirements	4
1-6. Power Requirements	5
1-7. Similar Receiver Equipment	5
2. DESCRIPTION	
2-1. Electrical Theory	5
2-2. Circuit Details	7
2-3. Power Supply	8
2-4. Construction	9
2-5. Remote Control	10
3. INSTALLATION	
3-1. General Installation Inspection	10
3-2. Bonding and Shielding	12
3-3. Location and Mounting of Receiver Equipment	12
3-4. Cable Connections	13
4. OPERATION	
4-1. Initial Tests and Adjustments	13
4-2. Phone Reception From the Local Position	13
4-3. CW Reception From the Local Position	14
4-4. Remote Function When Control is at the Local Position	14
4-5. Phone and CW Reception From the Remote Position	14
4-6. Local Functions With Control at Remote Position	14
5. MAINTENANCE	
5-1. Routine Inspection	14
5-2. Location and Remedy of Faults	16
5-3. Service Data	18
6. MATERIAL LISTS	
6-1. Type RA-1B Receiver	23
6-2. Type RA-1I Receiver	28
6-3. Type RA-1J Receiver	28
6-4. Type MR-1B Remote Control Unit	29
6-5. Type MR-1I Remote Control Unit	29
6-6. Type MR-1J Remote Control Unit	30
6-7. Type MP-5B Power Supply	30
6-8. Type MP-5A24 Power Supply	30

ILLUSTRATIONS

- Fig. 1 - Type RA-1B Aircraft Radio Receiver Equipment
- Fig. 2 - Type RA-1B Aircraft Receiver (Rear Oblique View)
- Fig. 3 - Type RA-1B Aircraft Receiver (Top View)
- Fig. 4 - Type RA-1B Aircraft Receiver (Bottom View)
- Fig. 5 - Type RA-1B Aircraft Receiver (Front Oblique View)
- Fig. 6 - Type MP-5B or MP-5A24 Dynamotor Filter Unit
- Fig. 7 - Type MR-1B Remote Control Unit
- Fig. 8 - Diagram of External Connections
- Fig. 9 - Type RA-1B Receiver Unit, Outline Drawing
- Fig. 10 - Type MR-38A Shock Mounting, Outline Drawing
- Fig. 11 - Type MR-1B Remote Control Unit, Outline Drawing
- Fig. 12 - Dynamotor Base Plate, Outline Drawing
- Fig. 13 - Remote Control Base Plate, Outline Drawing
- Fig. 14 - Type MP-5B or MP-5A24, Outline Drawing
- Fig. 15 - Schematic Diagram
- Fig. 16 - Type RA-1B Receiver, Block Diagram

INSTRUCTION BOOK
for
MODEL RA-1B, RA-11 AND RA-1J
AIRCRAFT RECEIVER EQUIPMENT

I. INTRODUCTION

I-1. FUNCTION

The Bendix Type RA-1B Receiver is a communication receiver designed for use in aircraft. It may be employed for the reception of continuous wave telegraph or radio telephone signals within frequency ranges of 0.15 to 1.5 megacycles (2000 to 200 meters) and 1.8 to 15.0 megacycles (166 to 20 meters). Three bands are used to give full coverage in each frequency range.

Aural direction finding and loop antenna reception may be obtained over a frequency range from 0.2 to 1.5 megacycles by using the receivers in conjunction with the Bendix Direction Finding Equipment.

The receiver is designed to be operated locally, using the controls mounted on its front panel, or from any remote point within the airplane through the use of Bendix Type MR-1B Remote Control Unit which includes duplicate operating controls.

The receiver may be operated from either a 12- or 24-volt storage battery supply, jumper connections being provided at a terminal board in the receiver chassis to permit arranging the circuit for 12- or 24-volt operation. The receiver will be supplied with the circuit arranged for 12-volt operation unless otherwise specified. As the power supply unit cannot be converted it is necessary to use the 12-volt (MP-5B) or 24-volt (MP-5A24) Dynamotor-Filter unit as required.

I-2. COMPOSITION

A Type RA-1B Receiver installation includes the following equipment:

<i>Item</i>	<i>Quantity</i>	<i>Description</i>	<i>Weight-lbs.</i>
A	1	Type RA-1B Receiver with cable plugs, with tubes (1-6K6G; 5-6K7G; 1-6R7G; 1-6L7G)	25.1
B	1	Type MR-38A Shockproof Mounting Base	1.4
C	1	Type MR-1B Remote Control Unit with Cable Plug	4.25
D	1	Type MP-5B Power Supply for 12/14-volt operation or	
	1	Type MP-5A24 Power Supply for 24/28-volt operation, with cable plugs.	8.9
E	1	Type AF6372 Shielded cable assembly, 2-conductor, 5 ft. long, not wired to plug. (Power Supply to ship's master switch.) Part number of the cable only is QB7633.	
F	1	Type AF9355 Shielded cable assembly, 8-conductor, 15 ft. long, not wired to plugs, (Receiver to Remote Control Unit.) Part number of cable only is B7553.	

Item	Quantity	Description	Weight-lbs.
G	1	Type AF9353 Shielded cable assembly, 6-conductor, 15 ft. long, not wired to plugs. (Power Supply Unit to Receiver.) Part number of cable only is B7544.	
H	2	Type QB15460 Flexible Tuning Shafts, 15 ft. long, all fittings are supplied but are attached to one end only.	
I	1	Instruction Book	

NOTE: Unless otherwise specified by customer, the tuning shafts and cables will be supplied in the above mentioned lengths.

The dimensions of the equipment are:

	Width	Height	Depth
Receiver with shockmount	9 13/16"	8 7/8"	16 1/8"
Remote Control Unit	9 3/4"	7 1/8"	3 1/4"
Power Supply	4 3/8"	7 1/2"	7 3/8"

1-3. ELECTRICAL CHARACTERISTICS

1-3-1. FREQUENCY BANDS

The frequency ranges covered by the receiver are divided into six operating bands, the end limits of which are as follows:

Band 115	to	.315 mc.
Band 2315	to	.680 mc.
Band 3680	to	1.5 mc.
Band 4	1.8	to	3.7 mc.
Band 5	3.7	to	7.5 mc.
Band 6	7.5	to	15.0 mc.

Extension of each tuning range beyond the nominal band limit provides an overlap of approximately 2%.

1-3-2. SENSITIVITY

The CW sensitivity of the receiver is 2 microvolts for a 50-milliwatt output when the volume control is adjusted to give a noise output of 5 milliwatts with no carrier input.

The MCW sensitivity of the receiver is 4 microvolts on Bands 4, 5 or 6 and is 5 microvolts or better on Bands 1, 2 or 3 for the standard output of 50 milliwatts into a 300-ohm load, with a signal to noise ratio of at least 4 to 1, and an input signal 30% modulated at 400 CPS.

1-3-3. SELECTIVITY

The selectivity of the receiver is indicated by the ratio of the input voltage off resonance to the input voltage at resonance, at given band width; and is observed by varying the input voltage to maintain a constant output level for frequencies off resonance. The selectivity of the Type RA-1B Receiver at representative frequencies follows:

Input Voltage	Total Band Width For Reference Frequencies		
	150 kc.	700 kc.	3000 kc.
10 times	7 kc.	15 kc.	18 kc.
100 times	13 kc.	24 kc.	28 kc.
1000 times	20 kc.	32 kc.	40 kc.

1-3-4. IMAGE REJECTION

The discrimination against image frequencies over the various ranges of the receiver is given in the following table:

Band	Frequency	Minimum Ratio
1315 mc.	200,000
2680 mc.	90,000
3	1.50 mc.	35,000
4	3.70 mc.	7,000
5	7.50 mc.	2,000
6	15.00 mc.	1,000

NOTE: As the frequency specified in each band is that at which the image rejection is poorest, considerably better minimum ratios will be assured for all other frequencies.

1-3-5. RESONANCE STABILITY

The resonance stability of the Type RA-1B Receiver is such that the signal variation through the 1.8 to 15.0 megacycle range will not exceed 1/4 of 1% of the signal frequency in kilocycles, and it will not exceed 1/2 of 1% of the signal frequency in kilocycles through the .15 to 1.5 megacycle range. These ratings will be obtained under the following conditions:

- A. Any 20°C temperature variations between the limits of -20° and +50°C.
- B. Humidity variation between zero and 100%.
- C. Battery voltage variation of 15%.
- D. Normal vibration as encountered in aircraft.
- E. Manipulation of the sensitivity control from maximum to minimum.

1-3-6. OVERALL FIDELITY

The overall fidelity characteristic of the Type RA-1B Receiver as measured from the antenna to the output terminals varies, on the different bands, due to the selectivity requirements in the range of 150 to 500 kilocycles.

On Band 1, .150 to .315 megacycles the output varies plus or minus 6 DB over the range of 200 to 1500 cycles per second, 2000 cycles per second is attenuated approximately 15 DB below the level at 1000 cycles per second.

On Bands 2 and 3, .315 to 1.500 megacycles the output varies plus or minus 8 DB over the range of 200 to 2000 cycles per second.

On Bands 4, 5 and 6, 1.800 to 15.00 megacycles the output varies plus or minus 6 DB over the range of 200 to 3000 cycles per second.

1-3-7. POWER OUTPUT

The output circuit of the Type RA-1B Receiver is designed for a 300-ohm load and will deliver over 500 milliwatts output at not over ten percent distortion when properly loaded. The maximum possible output is 1.5 watts.

1-4. ADDITIONAL EQUIPMENT REQUIRED

The following additional equipment will be required to effect satisfactory operation of the equipment.

<i>Item</i>	<i>Quantity</i>	<i>Description</i>
A	2	Type MR-8A Headphone Receiver or equivalent 500 ohm, head band type
B	1	Antenna-ground system (see Section 1-5)
C	1	Primary power source (see Section 1-6)

1-5. ANTENNA REQUIREMENTS

The Type RA-1B Receiver may be operated with a separate receiving antenna, or it may be operated with the transmitting antenna through the break-in relay contained in the transmitter. Provisions are included in the receiver for the use of a fixed or trailing antenna and the applicable Bendix Direction Finder Amplifier. Convenient selection by means of a three-position antenna switch (S15) marked DF, TA, and FA (Direction Finder Amplifier, Trailing Antenna, Fixed Antenna) facilitates rapid selection of whichever antenna connection is desired. The knob marked ANTENNA SWITCH selects the source of signal input to the receiver. When the airplane's fixed antenna is connected to binding post A, the antenna switch is set at FA, and the antenna is then connected directly to the receiver input. When the trailing wire antenna is connected to A, the antenna switch S15 is set at TA, and the trailing wire is connected to the receiver input through a fixed series condenser which serves to compensate for the varying characteristics of the trailing wire antenna. With the antenna switch set at DF, the input of the receiver is connected to the output of the Direction Finder Amplifier and terminal A is grounded by the antenna selector switch. In series with the antenna and the primary of the antenna coil assembly, through the band switch S1, is a small variable antenna trimmer condenser C81 which compensates for antennas of differing capacities.

When using a separate antenna for the receiver, the choice of location is governed by proximity to a suitable location for the receiving antenna lead-in. The best results cannot be obtained at any frequency if the lead to the receiving antenna is run around the interior of the fuselage for several feet before connecting to the antenna binding post. This is particularly harmful at high frequencies where dielectric losses are greater. A receiving antenna suitable for the entire frequency range of the receiver will not have a large capacity. Additional capacity to the fuselage between the lead-in insulator and the antenna binding post shunts the receiver and may seriously reduce the signal energy reaching it. The ideal installation would have the receiver connected to the antenna lead-in by means of a single insulated conductor suspended in air throughout its length. Conductors of #16 and #18 B & S gauge are suitable for radio receiving antenna connection inside the airplane. This lead should not be located so that it is likely to be struck or subjected to stress involving the tensile strength of the wire. If it is necessary that this lead be longer than one foot or support is required along its length, every effort should be made to space it away from metal structural members by at least one-half inch. Glass or porcelain stand-off insulators are ideal for this purpose, however, if they are not available, it is preferable to use dry wooden blocks impregnated with paraffin wax as spacers rather than to secure this conductor directly to metal members.

When the transmitting antenna is used in conjunction with the break-in relay for receiving, the wire connecting binding post A on the receiver and the RECEIVER binding post on the transmitter should be made as short and as direct as circumstances permit; care should be taken to prevent its coming into proximity with metallic bodies wherever possible.

In all cases the antenna leads must have slack, this eliminates any possibility of vibration being transferred to the receiver through the leads.

The ground binding post G should be connected by a heavy flexible wire to the nearest metal member of the fuselage using a firm clean joint, preferably soldered. This ground lead must be short, not exceeding a foot in length.

1-6. POWER REQUIREMENTS

For 12-volt operation the receiver filament current is 1.5 amperes and the type MP-5B power supply requires approximately 3 amperes. Receiver filament current of 0.8 amperes and approximately 1.5 amperes current for the type MP-5A24 power supply will be required for 24-volt operation. The total plate current for the receiver is approximately 70 milliamperes at 225 volts.

1-7. SIMILAR RECEIVER EQUIPMENT

1-7-1. TYPE RA-1I RECEIVER

When it is desirable to have a high-impedance output receiver, the Bendix Type RA-1I Receiver may be obtained. This unit is identical to the Type RA-1B Receiver except for the local dual volume sensitivity control (R39, R40) and the audio output transformer T1.

The Bendix Type MR-1I Remote Control Unit used in conjunction with the Type RA-1I Receiver differs only in the remote dual volume sensitivity control (R41, R42) used.

A 4000-ohm high impedance headset such as the Bendix Type MR-48A is required when using this equipment.

An additional parts list (Section 6-5) has been added to give information necessary when referring to the Type RA-1I Receiver Equipment.

1-7-2. TYPE RA-1J RECEIVER

The Bendix Type RA-1J Receiver is similar to the Type RA-1B Receiver except for the frequency ranges of the bands 4, 5, 6, and the values of the tuning components.

The calibrated end limits of each band are given below:

Band 1150 to	.315 mc.
Band 2315 to	.680 mc.
Band 3680 to	1.500 mc.
Band 4	2.500 to	5.000 mc.
Band 5	5.000 to	10.000 mc.
Band 6	10.000 to	20.000 mc.

The Bendix Type MR-1J Remote Control Unit used in conjunction with the Type RA-1J Receiver has its dials and dial mask marked to correspond with the receiver markings. An additional parts list (see Section 6-6) has been added to give information necessary when referring to the Type RA-1J Receiver.

2. DESCRIPTION

2-1. ELECTRICAL THEORY

The Type RA-1B Receiver follows conventional superheterodyne design. The basic principle involves the use of a fixed frequency amplifier, usually tuned to some intermediate radio frequency, hence the term IF amplifier. In the case of the Type RA-1B Receiver, this frequency is 1630 Kcs. All desired signals are tuned by means of a variable tuning control and are subsequently heterodyned or converted to the fixed amplifier frequency. After passing through the IF amplifier, the converted signal is detected or rectified in the second detector, and the audio components, which carry the desired intelligence or message, are amplified and fed into head

telephones.

The three main tuning condensers (antenna coupling transformers, RF amplifier transformer, and heterodyne oscillator) are ganged together for uni-control tuning, and their associated inductances and capacities are so chosen as to automatically maintain a constant difference of 1630 Kcs between the signal and heterodyne oscillator frequencies. Thus, for a 1000 Kcs signal, the RF amplifier and 1st detector are tuned to 1000 Kcs and the heterodyne oscillator is automatically set to 1000 plus 1630, or 2630 Kcs.

To illustrate the complete operation, assume, for example, that the receiver is tuned to an incoming signal of 1000 Kcs. In passing from the antenna to the grid of the first detector, the incoming signal will then be amplified through the RF amplifier tube and its associated tuned input and output transformers; whereas, signals of other frequencies will be amplified only slightly or not at all. The first detector will also have injected into it a second voltage originating in the heterodyne oscillator, which will have a frequency of 2630 Kcs, and the resultant of these two frequencies will appear in the output of the first detector. There will be two new frequencies in addition to the initial frequencies, namely: 1630 and 3630 Kcs, the difference between, and the sum of the original frequencies. The appearance of these new frequencies is a phenomenon of heterodyning which is similar to the beat obtained at audio frequencies when two tones of different pitch are sounded simultaneously.

The four frequencies (1000, 2630, 1630 and 3630 Kcs) are fed to the input of the 1st IF amplifier, which is tuned by a filter network to a band comprised of 1630 Kcs, plus and minus a few kilocycles. Consequently, the 1630 Kcs component is selected and amplified, while the other three are rejected, i.e., not amplified. This selection and amplification process is carried on further in the 2nd IF amplifier with its associated IF filters.

Simultaneously with the 1630-Kcs IF signal voltage, a 1631-Kcs CW oscillator voltage may be applied to the control grid of the 2nd IF amplifier tube through a coupling capacitor. These two voltages are amplified, passed through the final IF filters, and fed into the signal diode section of the 2nd detector tube. The output of the signal diode will then contain two frequencies 3261 Kcs and 1 kilocycle. The higher component will be filtered out by the resistance-capacitance filter associated with the signal diode circuit and the IF filter which couples the 2nd IF amplifier tube with the signal diode, or 2nd detector. The signal feed to the AF amplifier will be at 1 kilocycle. This produces an audible beat frequency signal which passes through the audio amplifier circuits and is fed to the head telephones.

The description above is for typical reception of unmodulated (CW) signals. When modulated continuous waves are being received, the CW oscillator is shut off. In this case, the amplitude modulation of the carrier at an audible frequency produces the audio signal which is heard in the output.

Automatic volume control is obtained from the second diode section in the 2nd detector tube. A portion of the 1630-Kcs output from the 2nd IF amplifier is rectified by this diode, suitably filtered by a resistance-capacitance filter, and applied to the control grid circuits of the RF amplifier, 1st detector, and 1st IF amplifier tubes through decoupling filters. Variations of incoming signal intensity result in corresponding changes of rectified voltage in the AVC diode circuit. These variations are transmitted to the above named control grids and serve to reduce the overall gain or sensitivity of the receiver when the incoming signal increases in amplitude, and vice versa, thus maintaining the output at a substantially constant level. This level may be adjusted by the potentiometer section of the dual volume control which determines the AF voltage applied to the grid of the output power tube.

Manual volume control is obtained by setting the AVC switch in the off position, thus substantially grounding the control voltage from the AVC diode. Control of volume is then accomplished by replacing the AVC voltage variation with that from the IR drop across a manually operated control which varies the cathode bias on the RF amplifier, 1st detector and 1st IF amplifier tubes.

2-2. CIRCUIT DETAILS

2-2-1. PANEL AND CONTROLS

The front panel of the receiver bears all the controls required for its operation. Viewing it from the front, one may note, in the upper left hand corner, three binding posts for connecting the antenna to Post A, Direction Finder (if used) to post DF, and post G to ground. Immediately to the right of these is the rotary antenna switch S15 which permits changing the receiver input for use with a direction finder DF, trailing antenna TA or fixed antenna FA, depending upon which type of antenna is connected to the binding posts. The antenna compensating condenser C81, is located at the right of the antenna switch. By turning the spring dust cover to one side, the condenser can be adjusted with a screw driver. Below the antenna switch is a projecting gear case, having an external knob marked TUNING. It contains a bevel-gear arrangement that permits the mechanical linkage of a remote control unit to the receiver. The TUNING control drives a precision, spring-loaded, worm gear which in turn drives the gang tuning condenser (C1.1, C1.2 and C1.3). The BAND SELECTOR located to the right of the tuning control has a similarly arranged mechanism, this has the external knob marked BAND SELECTOR. Along the bottom of the front panel, in succession from left to right, are the telephone jack J1, marked PHONES, the automatic volume control switch S8, marked A.V.C. OFF-ON, the CW switch S10, marked C.W. OFF-ON, the power switch S11 marked POWER OFF-ON, that operates the starting relay H1, a six-contact plug receptacle PL3 that receives the power cable from the dynamotor-filter unit and an eight-contact plug receptacle PL1 which connects to the remote control unit. Below and to the right of the band selector gear case are four pin jack terminals used for testing, G is the common terminal, B+ connects to the plate voltage bus, A+ connects to the heater voltage bus and AUDIO connects to the secondary highside of the output transformer. In the upper right corner is the VOLUME control (R39-R40). To the left of the volume control is the LOCAL-REMOTE transfer switch (S9). At the top center of the panel is the port through which the dial and dial mask are observed. A pilot light DL1 is enclosed in a small reflector case to the right of the dial port. Pilot lights may be changed by unfastening two screws which hold the cover in place. The case and front panel of the receiver are finished in a black wrinkle-enamel and all markings on the panel are engraved.

2-2-2. RF AMPLIFIER CIRCUITS

The input energy is taken from a fixed antenna, a trailing antenna, or a direction finder amplifier; choice of any one source is had by operation of the ANTENNA SWITCH. This energy is fed into the tuned antenna circuit coils L1 to L6 and their associated trimmer condensers, located in the ANTenna shield can.

The energy from the tuned antenna circuit is then fed into the radio frequency amplifier tube V1, which is a 6K7G triple-grid RF amplifier. This amplifier voltage then goes to the tuned circuits in the RF shield can, L7 to L12 and their associated trimmer condensers. The signal is then introduced into the first detector tube V3 (mixer stage).

The output of the heterodyne oscillator circuit, tuned 1630 kilocycles higher in frequency than the frequency of the desired signal, is injected into the mixer stage. This heterodyne oscillator circuit consists of a 6K7G oscillator tube V2 and the tuned circuits mounted in the OSCillator shield can, coils L13 to L18 and their associated padder and trimmer condensers.

Frequency conversion is accomplished by the heterodyne process, the tuned and amplified signal and the output of the heterodyne oscillator are simultaneously detected in the first detector (mixer) tube V3 whose output circuit FL1 is tuned to the intermediate frequency of 1630 Kcs. The first detector tube V3 (6L7G) has two separate control grids which are shielded from each other; use of this tube reduces the undesirable coupling effects between the oscillator and signal circuits to a minimum. The tuned circuits FL1 comprise a conventional 1630 Kcs, double-tuned, IF transformer.

2-2-3. IF AMPLIFIER CIRCUITS

Output of the first detector (mixer) tube V3 is fed through the tuned IF transformer FL1 to the first intermediate frequency amplifier tube V4. The transformer FL1 being tuned to 1630 Kcs passes signal energy of this frequency and attenuates all other frequencies. After amplification in the tube V4 the signal is fed through another tuned IF transformer FL2, that further attenuates undesired frequencies, into the second IF amplifier tube V5.

Provision has been made in the IF transformer FL2 to couple the output of the continuous wave beat frequency oscillator (CW Osc.). The CW oscillator tube V8 is a 6K7G operating at very low voltage. This oscillator is tuned to 1631 Kcs by the coil L27 and its associated condensers located in the CW, BFO shield can.

The second intermediate frequency stage consists of the IF amplifier tube V5 (6K7G) and a tuned circuit FL3. The output of V4 is amplified in the second IF amplifier tube V5; whenever the beat frequency oscillator tube V8 is used, its output is also amplified in the tube V5; the signal is then fed through the tuned IF transformer FL3 to the second detector tube V6. Transformer FL3 further attenuates signals of any undesired frequencies.

2-2-4. AVC AND AUDIO CIRCUITS

The duplex-diode triode tube V6 (6R7G) is used as a combined detector, audio amplifier, and automatic volume control tube. The signal input from FL3 is rectified in the diode portion of the tube and because of the current flow in the diode circuit a voltage is developed across the resistors R23 and R24, (see the schematic diagram). The audio voltage developed across resistor R24 is bypassed to eliminate the radio frequency component and is then applied to the grid of the triode section of the tube. This triode section amplifies the audio frequency signal. The rectified voltage developed across the resistors R23 and R24 is filtered and used to vary the bias on the tubes V1, V3 and V4. Any change in signal strength at the detector will cause a change in the DC bias voltage of the RF and IF tubes thus limiting the gain and acting to hold the signal level at the detector to a constant value. The output of the detector V6 is amplified in the audio output amplifier tube V7 (6K6G), and the audio output for headphones is obtained from transformer T1 in the plate circuit of the tube V7.

2-2-5. SENSITIVITY CONTROL CIRCUITS

When using AVC the receiver sensitivity is fixed. The receiver output is varied by rotating the dual volume control (R39 and R40). The potentiometer R40 is shunted across the secondary of the output transformer T1 to provide a means of varying the voltage delivered to the headphone jacks.

When AVC is not used the variable resistor R39 changes the cathode bias thus lowering the receiver sensitivity.

2-3. POWER SUPPLY

2-3-1. GENERAL, 12- OR 24-VOLT OPERATION

The Type RA-1B Receiver can be operated from either a 12- or 24-volt storage

battery supply.

- A. 12-volt operation requires the use of a Type MP-5B (12-volt) Dynamotor-Filter Unit; also, on the numbered terminal board located under the chassis, terminals 1 and 2 must be connected, terminals 3, 4 and 5 must be connected, terminals 6, 7 and 8 must be connected.
- B. 24-volt operation requires the use of a Type MP-5A24 (24-volt) Dynamotor-Filter Unit; also, on the numbered terminal board located under the chassis only the terminals 2 and 3 shall be connected.

It is not necessary to change pilot lights when changing from 12-volt to 24-volt operation as the dropping resistors R43.3 and R43.4 are in the circuit when the jumper is removed from connections 6, 7 and 8 of the terminal board.

The Schematic Diagram, Figure 15, shows the locations of the fuse. For 12/14-volt operation the fuse is a 10-ampere, 25-volt Littelfuse located in the primary lead of the power supply. For 24/28-volt operation the fuse is located in the high voltage lead of the dynamotor output. This fuse is a one-eighth ampere, 500-volt Littelfuse.

The Type MR-1B Remote Control Unit does not have to be changed when it is used with either 12- or 24-volt installations. The Type MP-5B and MP-5A24 Dynamotor-Filter Units are ruggedly constructed machines designed especially for aviation service. Each unit is mounted securely on top of a chassis that contains all of the necessary component parts required for its proper operation.

2-3-2. EXTERNAL CONNECTIONS

At one end of the filter box are four plug receptacles that provide for the convenient connection of the power cables incidental to the use of the dynamotor. The upper left plug receptacle PL7 receives the low voltage input from the airplane storage battery. The upper right plug receptacle PL4 receives the power cable from the receiver. The lower right plug receptacle PL5 supplies potentials suitable for use with Bendix Direction Finder Amplifiers. The lower left plug receptacle PL6 provides potentials for any of the various Bendix Interphone systems. These systems can be installed to provide as many positions as desired. The interphone ON-OFF switches operate independent of the receiver ON-OFF switch.

A PROTECTIVE FUSE (F1), is mounted in the dynamotor so that it is readily accessible from the terminal end of the dynamotor mounting box, and may be removed for inspection or replacement by removing the small knob provided for this purpose.

2-4. CONSTRUCTION

2-4-1. RECEIVER

2-4-1-1. GENERAL

The Type RA-1B Receiver is designed for dependable operation under severe and adverse service conditions, as all of its component parts are constructed to withstand any degree of vibration, temperature or humidity change encountered in the course of normal flight operation. The metal from which the equipment is fabricated is selected to withstand corrosion.

2-4-1-2. TYPE OF CONSTRUCTION

The chassis-case form of construction has been used. All controls are located on the front panel enabling the chassis to be withdrawn from its case for inspection or replacement of tubes without the inconvenience of disconnecting the cables or the flexible tuning shafts. The chassis is held in place in its case by three thumb screws, two of which are mounted along the top edge of the front panel, and the third is mounted at the center of the bottom edge. All tuning coils and their associated trimmer and padder condensers are mounted in aluminum shield cans, (See

Figure 3.) One can is used for each stage. The tuned circuits are connected to switch sections which are turned by the BAND SELECTOR knob. Whenever possible, resistors and bypass condensers are soldered to lugs mounted on bakelite boards; this practice facilitates replacement of parts and provides rigid support.

2-5. REMOTE CONTROL

2-5-1. TYPE MR-1B REMOTE CONTROL UNIT

The Type MR-1B Remote Control Unit, (Figure 1), is designed to work in conjunction with the Type RA-1B Aircraft Receiver, and is constructed to meet the same service requirements. All external connections are on the right end. All couplings for the flexible tuning shaft, and flexible band selector shaft are held in place by threaded fittings. Midway between the flexible shaft couplings is the eight-contact terminal receptacle (PL2) to which the receiver control cable connects.

2-5-2. DESCRIPTION OF CONTROLS

The Type MR-1B Remote Control (Figure 1) contains all of the operating controls found on the Type RA-1B Receiver panel except the antenna switch S15 and the local-remote transfer switch S9. In the upper left corner of the remote control panel is a telephone jack J2 marked PHONES, directly below is the VOLUME control (R41-R42); C.W. ON-OFF switch (S13), A.V.C. ON-OFF switch (S12), POWER ON-OFF switch (S14). To the right of the power switch is a second telephone jack J3, marked PHONES. In the top center of the MR-1B panel is the dial port marked FREQUENCY. The tuning dial and dial mask, seen through the dial port, have the same scales and band markings as the receiver. This dial port is illuminated by a dial light DL2 that is housed in a removable reflector. Near the right edge of the panel are the TUNING and BAND SELECTOR crank handles. These cranks connect through mechanical linkage to the corresponding receiver drives.

Operating control is transferred from the receiver to the remote control unit by turning the LOCAL-REMOTE switch located on the receiver. The circuits of the Type MR-1B Remote Control Unit are so arranged that the PHONE jacks J2 and J3 are connected to the output of the receiver regardless of the position of the LOCAL-REMOTE switch S9. Headphones may be used simultaneously at the receiver and remote locations; a listener at the location which does not have control may regulate the audio level in his phones by adjustment of the volume control, providing that the AVC switch at the location is in the ON position.

3. INSTALLATION

3-1. GENERAL INSTALLATION INSPECTION

Prior to the installation of any equipment a thorough visual and, if possible, electrical inspection of all parts should be made. A typical inspection procedure is given below:

3-1-1. MECHANICAL AND VISUAL INSPECTION

- A. Receiver Unit. Remove the receiver from its case. Observe whether any wires have broken or become loose and check all ceramic parts for cracks or breakage. If the receiver appears dusty, dry compressed air may be used to blow out this dust. A hand bellows may be used for this purpose. The use of extreme high pressure is objectionable as it may impose undue strains on some of the more delicate parts. Carefully inspect all exposed connections for short-circuits that may be caused by foreign materials, or misplacement of parts. Feel all parts to determine if any have become loose, especially see if all tubes are properly seated and making good contacts in their respective sockets. Manipulate all controls through their entire range of motion, noting any irregularities re-

quiring correction. The receiver must be locked in its case by the three knurled lock screws. The case must be locked and safety wired on its shockmount, after ascertaining that all the metallic pivots on the rubber shock absorbers have penetrated into their respective holes before trying to close the snap-slides.

- B. Remote Control Unit. The general procedure of inspection of the remote control unit is similar to that outlined for the receiver unit.
- C. Dynamotor-Filter Unit. The dynamotor relay should be checked for improper alignment of contacts, pitted or corroded contacts, and improper spring tension. The protective fuse should make good contacts in its holder, also, the fuse must be of the correct value. The dynamotor should not be taken apart by anyone not familiar with its mechanism. (See Sec. 5-1-1.) All cables must be firmly locked in their respective receptacles by the small spring tips on all electrical cable plugs, and by the threaded collars in the case of the mechanical cables.

3-1-2. ELECTRICAL PERFORMANCE

After all units have been inspected and are properly connected, the equipment should be tested for electrical performance. The following procedure is typical of installation performance checks.

- A. Set the LOCAL-REMOTE switch to LOCAL.
- B. Turn POWER switch on the receiver to ON.
- C. Plug a telephone headset into PHONES jack on receiver.
- D. Adjust VOLUME control to maximum.
- E. Turn BAND SELECTOR control on receiver to any band.
- F. Turn CW switch to OFF.
- G. Operate TUNING control until a signal is heard, at which time the antenna compensating condenser C81 should be adjusted. Turn the small snap cover and, with an insulated screwdriver, adjust condenser until maximum signal output is obtained. The cover must be turned to close the adjustment opening.
- H. Turn AVC switch to ON.
- I. Vary the VOLUME control and note if smooth reduction of volume is obtained.
- J. Turn the AVC switch to OFF and again vary the VOLUME control while noting if smooth reduction of volume is obtained.
- K. Turn the CW switch to ON and note if beat is heard in the headphones.
- L. Turn LOCAL-REMOTE switch to REMOTE and repeat all checks in this position.
- M. Check remote dial against the receiver dial, making certain that they are properly aligned; all readings should be identical.

It will be noted that at either remote or receiver positions, with the AVC switch ON, the VOLUME control functions to control the headphone volume at its position regardless of the position of LOCAL-REMOTE switch. The circuits are arranged in this manner so that, if the local operator should have control of the receiver, the pilot at the remote position may control the volume in his headphones by turning the AVC switch to ON. This may be done without affecting any of the local operator's controls. The controls should be checked to see if they operate in this manner.

Tune in several stations on each band at both the local and remote positions while

making the above checks to assure correct operation of the equipment.

The above checks will indicate proper connection and operation of the receiving equipment. To check overall performance of the installation, tune in a weak station in any band and turn airplane's motors up to at least 1200 RPM, noting in headphones if any interference is introduced. Repeat this check on each band. Operate the battery-charging generator-field switch with motors turning 1200 RPM to be sure that no interference originates in the generator. If any interference is caused by either motors or generators, bonding and shielding must be examined and corrected.

3-2. BONDING AND SHIELDING

Before the Type RA-1B Receiver Equipment is installed, the aircraft engine, charging generator, ignition system and all electrical accessories must be completely bonded and shielded, if satisfactory radio results are to be obtained.

As the ultimate sensitivity of any aircraft receiving installation is limited by the magnitude of the local interference caused by ignition noises, etc., rather than by the sensitivity of the receiver, it is necessary if reception of weak signals is desired that the interfering signal be reduced to the lowest possible value by proper bonding and shielding.

A test to determine the completeness of bonding and shielding would be: With the airplane in flight or with the engine turning up at least 1200 RPM on the ground in clear weather when atmospheric static is negligible and the receiver volume control set at maximum, negligible sound should be audible in the telephone receivers over that which is heard with the engine not running. If the airplane is maintained in a well bonded and shielded condition, extremely long distance ranges of reception will be obtained by the Type RA-1B Receiver.

3-3. LOCATION AND MOUNTING OF RECEIVING EQUIPMENT

The receiver shockproof mounting base (Figure 10) should be attached to a plane surface at a location in the airplane that has been chosen for both the shortest practicable lead to the receiver antenna binding post and convenient access to the main tuning controls on the front panel. When determining this location, care must be taken to choose one that permits the receiver to vibrate freely in all directions without striking any other equipment or portion of the airplane. After these requirements have been met, and the mounting base has been permanently secured, the receiver should be attached to it by means of snapslides associated with the mounting brackets on the under side of the case. The snapslides must all be firmly engaged on their respective studs and securely closed.

The Type MP-5B or MP-5A24 Dynamotor-Filter Unit (Figure 14) should be located in such a position that the battery leads are kept as short as possible, and the longitudinal plane of the dynamotor shaft be as near parallel to the airplane line of flight as possible; also, consideration should be given to the placement of the connecting cables and the necessity for occasional removal for inspection of the dynamotor-filter unit. The mounting plate (Figure 12) should be permanently fastened in the location selected and the dynamotor-filter unit attached to it by means of the four snapslides provided for this purpose.

The remote control unit (Figure 11) must be so located that all controls are readily available to the pilot. The dial must be easily seen by the pilot when in flight. Care should be used in locating the remote control and receiver units so that no sharp bends will be required in the mechanical cables used for tuning and band switching. The remote control mounting base (Figure 13) should be securely fastened at the chosen location and the remote control unit attached to it, using the snapslides to hold the unit in place.

3-4. CABLE CONNECTIONS

The electrical connections of the Type RA-1B Receiver Equipment (Figure 8) are made by selecting first the battery cable, from one end of which project two wires marked to indicate their polarity. These are connected to the terminals of the storage battery voltage supply line. The plug at the opposite end of the battery cable is inserted in the two-contact receptacle PL7 on the base of the dynamotor-filter unit. The Type RA-1B Receiver is connected to the dynamotor through the power cable, one end of which plugs into the six-contact receptacle PL4 on the dynamotor base; the other end is inserted into the six-contact receptacle PL3 on the front panel of the receiver. The Type MR-1B Remote Control Unit is connected to the receiver electrically by the control cable which runs from the eight-contact receptacle PL2 on the side of the remote control unit to a similar eight-contact receptacle PL1 on the front panel of the receiver.

The TUNING and BAND SELECTOR controls on the remote control unit are mechanically linked to the corresponding TUNING and BAND SELECTOR controls on the receiver by two flexible mechanical shafts. The ends of these shafts terminate with spline joints and are securely held in place by threaded collars.

Before connecting the flexible mechanical shafts to the TUNING and BAND SELECTOR controls, the remote and local controls must be set to corresponding positions. Set the TUNING controls of the receiver and remote controls to read zero. Set the BAND SELECTOR control of both units so that the index line of each is in the center of the port for Band 1. The flexible mechanical shafts may then be connected by engaging the female fittings at the ends of each shaft with the proper male couplings on the receiver and remote control unit and securing the coupling nuts.

4. OPERATION

4-1. INITIAL TESTS AND ADJUSTMENTS

Prior to each flight the Type RA-1B Receiver should be checked for performance. This check should include, from both local and remote control points, a listening test on each band to determine:

- A. PHONE reception.
- B. CW reception.
- C. AVC action.
- D. MVC action.
- E. VOLUME control.
- F. TUNING.
- G. BAND SELECTION.
- H. LOCAL-REMOTE operation.

Any other equipment used in connection with this receiver, such as, a direction finder, interphone system, etc., should also be checked at this time. It must be determined which position is to have control during flight so that LOCAL-REMOTE switch on the receiver may be set to the correct position.

4-2. PHONE RECEPTION FROM THE LOCAL POSITION

- A. Turn ANTENNA SWITCH to TA for use of receiver with a trailing antenna, turn ANTENNA SWITCH to FA for use with fixed antenna.

- B. Turn CW switch to OFF.
- C. Turn LOCAL-REMOTE switch to LOCAL.
- D. AVC switch may be ON or OFF as desired.
- E. Turn POWER switch to ON and allow receiver about fifteen seconds to warm up.
- F. Turn BAND SELECTOR knob until the desired band is selected. (The dial mask gives band number and frequency limits.)
- G. Turn the TUNING knob until the desired frequency is obtained. (The scale, marked in frequency, is to be used when setting the receiver to a station whose frequency is known.) When stations have been previously logged on the linear scale, turn the tuning knob until the dial scale is on its logged number, then turn the TUNING knob in a clockwise direction until its scale (0-100) is on its logged number; this latter method allows exact resetting of the receiver.
- H. With the AVC switch OFF, strong signals may cause overloading of the audio circuits; the VOLUME control should be reduced to give the desired output level in the headphones.

4-3. CW RECEPTION FROM THE LOCAL POSITION

The only changes to the above procedure are:

- B. Turn CW switch to ON.
- D. AVC switch must be OFF.

4-4. REMOTE FUNCTIONS WHEN CONTROL IS AT THE LOCAL POSITION

When the LOCAL-REMOTE switch is at LOCAL, a listener at the remote point can vary the TUNING and BAND selection. The listener is able to vary his headphone VOLUME, provided his AVC switch is ON.

4-5. PHONE AND CW RECEPTION FROM THE REMOTE POSITION

All controls at the REMOTE position are duplicates of those at the local position except the ANTENNA SWITCH and LOCAL-REMOTE switch. It is necessary to set the ANTENNA SWITCH to the proper type of antenna connection, and the LOCAL-REMOTE switch must be turned to REMOTE before operating from the remote position.

4-6. LOCAL FUNCTIONS WITH CONTROL AT REMOTE POSITION

The listener at the local position may change the type of antenna being used by turning the ANTENNA SWITCH, he may return full control of the receiver to his position by turning LOCAL-REMOTE switch to LOCAL, he may vary the TUNING and BAND SELECTOR controls, and he may control the headphone VOLUME at his position if his AVC switch is ON, even though control is at the REMOTE position.

5. MAINTENANCE

5-1. ROUTINE INSPECTIONS

Regular inspections should be made preceding each flight.

- A. All interconnecting cables should be checked to see that they are securely locked in their receptacles. The snapslides fastening the receiver, dynamotor and the remote control units should be locked in place with safety wires.
- B. Check the airplane battery with a hydrometer.
- C. Check the operation of the voltage regulator of the charging generator, adjusting, if necessary, to insure consistent operation of the generators at 14 volts to 15 volts.

- D. Clean the antenna insulators, especially any which may be exposed to the engine exhaust or propeller blast.
- E. Check connections of lead-in wire, both at antenna and at receiver ends.
- F. If the receiver is functioning properly with the dynamotor background noise at a suitably low level, do not disturb the dynamotor unit.

Each inspection should include a listening test made on at least one point in each band of the receiver. The operation of all controls should also be checked. (See Section 3-1.) Any major trouble should be apparent from these tests. After each 500 hours of use, the equipment should be completely overhauled.

The receiver should be checked as in Installation Inspection, Section 3-1, in addition the tubes should be tested, all voltages checked to the values given in Section 5-3-1, and the general performance compared to the figures given in Electrical Characteristics, Section 3-1. Any defective parts should be replaced.

If realignment is necessary, it should be done by competent personnel, using the equipment and methods listed in Section 5-3-2.

The remote control unit should be checked for tightness and performance.

5-1-1. LUBRICATION OF DYNAMOTOR

The dynamotor-filter unit consists of a mounting box and the dynamotor. The relay H1 in the mounting box should be checked to see if the points are misaligned or pitted, and the spring tension should also be checked. The dynamotor will require lubrication every 500 hours of operation. At this time, it should be cleaned and inspected for wear. If a major overhaul is required, the dynamotor should be sent to a shop equipped to service such units. A recommended lubricant is Royco No. 6A grease; supplied by Royal Engineering Company, East Hanover, New Jersey.

The following precautions should be observed during inspection and assembly of the dynamotor unit:

- A. Bearings should be properly lubricated and free from grit.
- B. Commutators must be smooth and free from dirt and grease.
- C. All mica between commutator bars must be undercut.
- D. Brushes must fit freely in their boxes without excessive side play.
- E. Brushes and brush rigging must be clean.
- F. Brushes should be installed in same position in box as before disassembly.
- G. Brush leads should be shaped so that wire is parallel to brush travel.
- H. Brush springs must have required spring tension.
- I. Armature must be installed with low voltage commutator at the low voltage head.
- J. Pole shoes, if removed, should be replaced in their exact former position.
- K. All spacers and washers must be correctly located.
- L. End cover felts must be in their proper position.
- M. End covers should be tight.
- N. All wiring must be connected as per schematic diagram.
- O. Replace all locking devices and safety wire.

The dynamotor should then be "run in" unloaded using a fully charged 12-volt battery, a "run in" time of approximately two to four hours should be sufficient to obtain proper seating of brushes. After this, the dynamotor may be checked for output at full load.

5-2. LOCATION AND REMEDY OF FAULTS

5-2-1. GENERAL

The location of open and short circuit faults will be facilitated if, instead of testing at random points, an orderly procedure is followed. Using the schematic diagram for guidance, test one portion of a circuit at a time, and successively check each element contained in that portion for open circuits, short circuits, and grounds by measuring the resistance from point to point with an ohmmeter. If the measured values of resistance are normal, as compared with the resistance chart in Section 5-3-1, that particular portion of the circuit is probably not at fault and needs no further attention. The identifying symbols of all components are given on the diagrams and their normal values can be determined by reference to Section 6.

The following table lists the average signal input required at the grid of each of the amplifier tubes to produce a standard output of 50 milliwatts into a 300-ohm load. In making these comparison measurements, the signal generator output should be connected from grid to ground. In the case of RF and IF amplifier tubes, the grid clip is removed and a 0.5 megohm resistor is shunted from grid to ground. A 0.01 Mfd coupling condenser is used between the signal generator and grid. The grid of the heterodyne oscillator tube V2 should be shorted to ground while testing the IF amplifier. When checking AF amplifier operation, it is not necessary to break the normal grid connection to the tube. The connection to the grid of V6 may be made to the cap of the tube through a 0.1 Mfd coupling condenser with the clip in place. To introduce signal voltage to the grid of V7, it will be necessary to connect the signal generator output across R37 on the underside of the chassis. All measurements should be made with AVC OFF, and the volume control at its maximum clockwise position. For RF measurements, a signal of the specified frequency modulated 30% at 400 CPS should be used. A 400-cycle signal source is used in making AF measurements.

<i>tube</i>	<i>Band</i>	<i>Frequency</i>	<i>Input Microvolts for Standard Output of 50 MW</i>
V1	1	.15 mc.	3.0
V1	2	.315 mc.	3.0
V1	3	.680 mc.	4.0
V1	4	1.80 mc.	3.0
V1	5	3.70 mc.	3.0
V1	6	7.50 mc.	5.0
V3	IF	1.630 mc.	75
V4	IF	1.630 mc.	1,500
V5	IF	1.630 mc.	75,000
V6	AF	400 CPS	.2 Volts
V7	AF	400 CPS	3.0 Volts

By comparing the receiver performance with these data, the location of operational faults will be greatly facilitated. It is recommended that the stages be checked in reverse order; i.e., V7 through V1.

Should it become necessary to remove either the tuning or band selector knobs, take out the 6-32 holding screw in the center of the knob and replace with an 8-32 brass

screw. The knob is tapped for an 8-32 screw and the shaft is tapped for a 6-32 screw; therefore, the end of the 8-32 screw will press against the end of the shaft and force the knob off without any danger of springing the shaft.

CAUTION: During the assembly of the condenser and drive mechanism to the receiver chassis and panel, all screws (including shaft-coupling set-screws) are tightened while the condenser is connected to a capacity measuring instrument. Any change in the condenser capacity due to torsional strains, etc., is noted and corrected while the assembly screws are being tightened. Do not loosen any screws involving the condenser drive assembly unless it becomes absolutely necessary, as the receiver will have to be recalibrated following any such changes.

The heterodyne oscillator coil assembly has also been very carefully assembled and adjusted, and any work done on or in it will necessitate recalibrating the receiver.

5-2-2. NO SIGNAL OR WEAK SIGNAL

With no signal or very weak signal, in any position of the tuning dial or band selector switch, the following checks may be made to determine the trouble.

- A. Turn the POWER switch to ON.
- B. Plug phones in the receiver jack marked PHONES to eliminate the possibility of trouble in the remote unit.
- C. Turn the LOCAL-REMOTE switch to LOCAL.
- D. Turn the VOLUME control to maximum.
- E. Check the PROTECTIVE FUSE in the dynamotor.
- F. Try the ANTENNA switch on its three positions to check its operation.
- G. Check antenna connections for an open or shorted condition.
- H. Measure the filament and plate supply voltages at the panel jacks marked A+ and B+.
- I. Listen for audio output through the pin jack marked AUDIO to eliminate the phone jacks and volume control. Be sure that all tubes are lighted, and that the grid clips are connected securely to the grid caps.
- J. Removal of the grid clip on V6 will cause a click to be heard in the headphones, if the audio stages of the receiver are functioning. If this click is absent, check the audio tubes V6 and V7. If this does not expose the trouble, check the voltages in the tube sockets. (See Section 5-3-1-1.)
- K. Tap the grid of the second IF amplifier V5. A sharp click should be heard if the receiver is functioning following that tube. If a click is not heard, check the tube and the voltages at that tube socket (see Section 5-3-1-1). This check may be repeated on tubes V4 and V3. Check the operation of the high frequency oscillator by connecting a voltmeter to the screen of the tube V2, and note if the voltage (approx. 85 volts) drops when your finger is placed on the grid cap. If the voltage does not vary, the high frequency oscillator coil can should be checked. Remove the antenna and connect a short piece of insulated wire to it. Wrap the insulated wire around the lug on the front of the antenna coil can and note any change in output. If the signal increases, the antenna switch assembly should be checked.
- L. Wrap the insulated antenna wire around the grid clip of tube V1 and note any change in output. If the signal increases the antenna can assembly should be checked.
- M. Wrap the insulated antenna wire around the grid clip of tube V3 and note any change in output. If the signal increases check vacuum tube V1.
- N. Check the voltages at the tube socket of V1.

O. Check the RF can assembly.

5-2-3. INTERMITTENT OR NOISY OPERATION

- A. Check all electrical plugs for good contact.
- B. Check for loose or shorted antenna connection.
- C. Check headphone cord for open circuit while being moved about.
- D. Make sure all tubes are pushed all the way in their sockets.
- E. Check all grid clips.
- F. Check all tube shields.
- G. Make certain that no section of the ganged tuning condenser is shorting.
- H. Tap all tubes IF filters and RF can assemblies for intermittent contacts.
- I. Inspect and tap all parts on the lower side of chassis for mechanical rigidity.

5-3. SERVICING DATA

5-3-1. RESISTANCE - VOLTAGE ANALYSIS

5-3-1-1. TUBE SOCKET VOLTAGES

All measurements are made to ground. The AVC is turned off and the volume control set to its maximum clockwise position. Variations $\pm 10\%$ are normal and do not affect the operation of the receiver. The measurements shown below were made with a 1000-ohm per volt meter, Weston Model 697, or equivalent. Inasmuch as it is impractical to use the same meter range for all measurement, the meter ranges have arbitrarily been designated for purposes of tabulation as follows:

A	0-7.5	C	0-150
B	0-15	D	0-750

In the table, all voltages are followed by the reference letter of the range used in making the measurement.

Tube	Socket Terminal and Corresponding Tube Elements						
	1	2 to 7	3	4	5	6	8
V1-RF Amp:	0	6.2 (A)	205 (D)	70 (C)	2.6 (A)	.	2.6 (A)
V2-HF Osc:	0	6.5 "	170 "	85 "	0	.	0
V3-1st Det:	0	6.2 "	210 "	98 "	0	.	5.55 "
V4-1st IF:	0	6.3 "	205 "	70 "	2.75 "	.	2.75 "
V5-2nd IF:	0	6.3 "	187 "	70 "	2.5 "	.	2.5 "
V6-2nd Det:	0	6.2 "	47 (C)	0	0	.	0
V7-2nd Audio:	0	6.3 "	205 "	213 (D)	0	.	15.0 (C)
V8-CW Osc:	0	6.1 "	2.7 (B)	2.7 (B)	0	.	1.8 (A)

Tip jacks; A+ to G: 14 (C), B+ to G: 220 (D)

5-3-1-2. RESISTOR VOLTAGE DROP MEASUREMENTS

The following tabulation lists the average voltage drop across the various resistors located on the underside of the chassis. The indicated voltage is the normal

expected drop across the particular resistor with a battery potential of 14 volts, and with the volume control full on, AVC off and CW oscillator off. Variations of $\pm 10\%$ from the tabulated voltages may be considered normal.

The system of indicating the meter range used in taking the measurements is the same as that adopted in Section 5-3-1-1. Here as well, the various ranges are arbitrarily designated as follows:

A 0-7.5	C 0-150
B 0-15	D 0-750

The reference letter of the scale follows each indicated voltage.

<i>Symbol Voltage</i>	<i>Symbol Voltage</i>	<i>Symbol Voltage</i>
R1 0	R7 0	R12 95. (C)
R2 2.25 (A)	R8 68. (C)	R13 1.25 (A)
R3 2.6 (A)	R9 41. (C)	R14 0
R4 3.85 (A)	R10 84. (C)	R15 2.4 (A)
R5 0	R11 5.5 (A)	R16 2.9 (A)
R17 3.5 (A)	R29 0	R39 0
R18 2.35 (A)	R30 0	R40 0
R19 2.95 (A)		R43.1 12.2 (B)
R20 19. (C)	R32 2.7 (B)	R43.2 6.1 (A)
R21 62. (C)	R33 1.15 (A)	R44.1 0
R22 115. (C)	R34 91. (C)	R44.2 11.5 (B)
R23 0	*R35 .15 Neg. (A)	R45 0
R24 0	R37 0	
R26 142. (C)	R38 15. (C)	

*C.W. Switch On

5-3-1-3. POINT-TO-POINT RESISTANCE MEASUREMENTS

The following table indicates the average resistance to be expected when measured from the terminals of the various tube sockets to ground with the Weston Model 697 Selective Set Servicer. The power cable should be connected between the receiver and receiver dynamotor but the filament power switch must be turned off. The AVC and CW switches should be off and the volume control turned to its maximum clockwise position.

<i>Tube</i>	<i>Socket Terminals</i>							
	1	2	3	4	5	6	7	8
V1	0	5.5 (A)	1,550 (B)	14,500 (B)	500 (B)	.	4.8 (A)	500 (B)
V2	0	0	5,300 (B)	18,000 (B)	0	.	3.9 (A)	0
V3	0	5.0 (A)	1,500 (B)	24,000 (B)	45,000 (B)	.	3.9 (A)	1,000 (B)
V4	0	1.3 (A)	1,400 (B)	14,200 (B)	500 (B)	.	4.8 (A)	500 (B)
V5	0	3.2 (A)	5,400 (B)	14,000 (B)	500 (B)	.	1.5 (A)	500 (B)
V6	0	2.0 (A)	45,000 (B)	500,000 (B)	500,000 (B)	.	4.0 (A)	0
V7	0	0	890 (B)	500 (B)	1 Meg (B)	.	2.0 (A)	750 (B)
V8	0	4.2 (A)	200,000 (B)	80,000 (B)	0	.	4.2 (A)	*

J4 Test jack - ground	0
J5 Test jack - audio	° 17 (A)
J6 Test jack - A+	1.5 (A)
J7 Test jack - B+	500 (A)
*C.W. Switch Off.	No Connection
	° No Load
C.W. Switch On.	0 Ohms
	(A) X10 Scale
	(B) X100 Scale

5-3-2. TRIMMER ALIGNMENT

WARNING: DO NOT CHANGE THE SETTING OF ANY TRIMMER CAPACITOR UNLESS THE NEED OF SUCH ADJUSTMENT IS DEFINITELY ESTABLISHED. NO ADJUSTMENT SHOULD BE MADE, IN ANY CASE, UNTIL THE FOLLOWING INSTRUCTIONS ARE CAREFULLY READ AND THE PROPER PROCEDURE THOROUGHLY UNDERSTOOD.

5-3-2-1. GENERAL

Should it become necessary to realign the receiver, it should be permitted to warm up for fifteen minutes before any adjustments are made.

The shielding compartments of the antenna, RF and oscillator stages (Figure 3) are provided with cover slides which protect the coils and trimmer condensers from dust. Loosening the two screws in each cover plate permits sliding the plate along to expose the condenser shafts for adjustment.

A signal generator with a low-impedance output and a 300-ohm output meter are necessary to align the Type RA-1B Receiver. A high-impedance headset may be placed in parallel with the output meter for monitoring. The signal generator must be capable of delivering the following frequencies with precision:

.150 Mcs	1.800 Mcs
.315 Mcs	3.700 Mcs
.680 Mcs	7.500 Mcs
1.500 Mcs	15.00 Mcs
1.630 Mcs	

5-3-2-2. IF AMPLIFIER ALIGNMENT

Remove the RF grid clip from the converter tube V3. Connect an 0.5 megohm resistor from the grid of V3 to ground. Connect the shield of the signal generator output cable to the tube shield can and connect the high potential lead from the generator to the grid of V3 through a 0.01 Mfd condenser.

- A. Short the grid of the oscillator V2 to ground.
- B. Turn the VOLUME control to maximum.
- C. Turn the LOCAL-REMOTE switch to LOCAL.
- D. TURN THE A.V.C. switch to OFF.
- E. Turn the C.W. switch to OFF.
- F. Plug the output meter into the receiver jack marked PHONES.
- G. Set the signal generator accurately at 1.630 Mcs with 30% modulation at 400 CPS.
- H. Adjust the trimmer condensers C54, C58, C59, C60, C62, and C63 on intermediate frequency transformers FL1, FL2 and FL3 for maximum output as indicated by the output meter, (Figures 2 and 5.) Keep the signal from the generator as low as possible at all times. Vary the signal generator frequency and set for maximum on the output meter. Read the signal generator frequency, and, if it is not 1630

Kcs, repeat the previously described alignment of intermediate frequency transformers FL1, FL2, and FL3 with the generator accurately reset at 1630 Kcs.

- I. The input at resonance should be approximately 50 microvolts for an output of 50 milliwatts into a 300-ohm load; the total IF band width at 1000 times the resonant input is 45 Kcs or less.

While the signal generator is at exactly 1.630 Mcs turn off the modulation and turn the C.W. switch to ON. Adjust C71 on the CW oscillator can (Figure 5) for zero beat in the phones. The CW oscillator tube will then oscillate at the exact IF frequency and the zero beat method of aligning the oscillator stage can be employed. After completion of alignment, the CW oscillator should be readjusted to 1.631 Mcs for the 1000 cycle per second difference frequency.

5-3-2-3. HF OSCILLATOR ALIGNMENT

Connect the low potential lead from the signal generator to the ground post G of the receiver.

Connect the high potential lead from the signal generator to a 100 Mmf condenser which in turn is connected to the antenna post A on the receiver.

- A. Turn the ANTENNA SWITCH to FA.
- B. Turn the A.V.C. switch to OFF.
- C. Turn the C.W. switch to ON.
- D. Turn the VOLUME control knob to maximum.
- E. Turn the LOCAL-REMOTE switch to LOCAL.
- F. Turn the BAND SELECTOR switch of the receiver to BAND 1.
- G. Turn the TUNING knob of the receiver so that the MEGACYCLES dial reads .315 Mcs on the calibrated scale.
- H. Log the setting of the linear scale and TUNING knob so that it can be reset with precision.
- I. Turn the spring dust cover to one side and adjust the antenna compensating condenser C81 (Figure 2) for maximum capacity.
- J. Set the signal generator to give approximately 50-microvolt unmodulated output at exactly .315 Mcs.
- K. Adjust the oscillator trimmer condenser C35 on Band 1 for zero beat in the headphones.
- L. Set the signal generator to exactly .150 Mcs.
- M. Turn the TUNING knob of the receiver so that the MEGACYCLES dial reads .150 Mcs on the calibrated scale, and log the setting.
- N. Adjust the oscillator padder condenser C41 for zero beat. (Use a non-metallic screw driver.)
- O. Reset the signal generator to .315 Mcs.
- P. Retune the receiver to .315 Mcs by means of the logged setting.
- Q. Readjust trimmer condenser C35 for zero beat.

These adjustments at the ends of the band must be repeated until the last adjustment when checked does not have to be altered.

The above procedure has been described for aligning the oscillator on Band 1. The same procedure may be used on the other bands. The following tables lists the trimmer and padder condenser numbers to be used with the various bands at the end fre-

quencies. (See Figures 3 and 5.)

Band No.	HIGH FREQ. END OF BAND		LOW FREQ. END OF BAND	
	Freq. Mcs	Trimmer Cond. No.	Freq. Mcs	Trimmer Cond. No.
1	.315	C35	.150	C41
2	.680	C36	.315	C42
3	1.500	C37	.680	C43
4	3.700	C38	1.800	C44
5	7.500	C39	3.700	C45
6	15.000	C40	7.500	C46

5-3-2-4. ANTENNA AND RF STAGE ALIGNMENT

Connect the signal generator to the receiver as in Section 5-2-1 and adjust the receiver controls as for alignment of the HF oscillator, except that the C.W. switch should be turned to OFF.

- A. Adjust the signal generator to 30% modulation at 400 CPS.
- B. Set the signal generator at exactly .315 Mcs.
- C. Turn BAND SELECTOR switch to BAND 1.
- D. Tune the receiver to .315 Mcs.
- E. Adjust signal voltage to obtain a receiver output of approximately 50 milliwatts.
- F. Adjust RF trimmer condenser C29 for maximum indication of output meter.
- G. Adjust antenna trimmer condenser C16 for maximum indication of output meter.
- H. Decrease the signal generator output voltage as trimmers are adjusted to keep output of receiver at 50 milliwatts or less.
- I. Final adjustments should be made using a signal generator output of five microvolts. The receiver sensitivity control should be decreased as necessary to keep the receiver output at approximately 50 milliwatts.

The above procedure describes the adjustments necessary to align the antenna and RF stages on BAND 1.

Repeat the above procedure at the high frequency ends of the remaining bands, using the frequencies and adjusting the trimmer condensers listed in the table below: (See Figure 3).

Band No.	Freq. Mcs	Antenna Trimmer	RF Trimmer
1	.315	C16	C29
2	.680	C17	C30
3	1.500	C18	C31
4	3.700	C19	C32
5	7.500	C20	C33
6	15.000	C21	C34

RA 1B receiver 17287 ✓
 MP 5B power unit 17288 ✓

6. MATERIAL LISTS

6-1. TYPE RA-1B RECEIVING EQUIPMENT

Symbol	Function	Description	Mfr's Type No.	Mfr.	Bendix Number
CAPACITORS					
C1.1	Antenna Tuning	1st Sec. 348 Mmf Max.			
C1.2	RF Tuning	3 Gang 2nd Sec. 241 Mmf Max.		2	QE15189
C1.3	Osc. Tuning	3rd Sec. 241 Mmf Max.			
C2.1	V4 Grid Return Bypass				
C2.2	V3 Plate Bypass	3 x .1 Mfd 400V DCW Oil-paper	A206-2	3	A206-2 17
C2.3	V1 Screen Bypass				
C3.1	V1 Cathode Bypass				
C3.2	V3 Screen Bypass	3 x .1 Mfd 400V DCW Oil-paper	A205-2	3	A205-2 17
C3.3	V3 Cathode Bypass				
C4.1	V3 Grid Return Bypass				
C4.2	V2 Screen Bypass	Same as C3			
C4.3	V2 Plate Bypass				
C5.1	V4 Cathode Bypass				
C5.2	V4 Screen Bypass	Same as C2			
C5.3	V3 Screen Bypass				
C6.1	V4 Plate Bypass				
C6.2	V5 Cathode Bypass	Same as C2			
C6.3	V5 Screen Bypass				
C7	V1 Grid Return Bypass	.1 Mfd 400V DCW Oil-paper	A204-1	3	A204-1 17
C9.1	V1 Plate Bypass				
C9.2	B + Supply Bypass	Same as C3			
C9.3	Screen Supply Bypass				
C10.1	V8 Plate Bypass				
C10.2	AVC Filter	Same as C3			
C10.3	V5 Plate Bypass				
C11	V7 Cathode Bypass	1.0 Mfd 100V DCW, Paper	VC 1541	3	B4991 17
C12	Antenna Coupling Band 1	10 Mmf $\pm 10\%$, 500V DCW Mica	1468 with XM262 4 Case		C56315-100
C13	Antenna Coupling Band 2	Same as C12			
C14	Antenna Coupling Band 3	5 Mmf $\pm 10\%$, 500V DCW Mica	1468 with XM262 4 Case		C56315-050
C15	Antenna Coupling Band 4	Same as C12			
C16	Antenna Trimmer Band 1	50 Mmf Var. Spec. Invar. Silver Plated	APC	5	B7175-15
C17	Antenna Trimmer Band 2	Same as C16			
C18	Antenna Trimmer Band 3	Same as C16			
C19	Antenna Trimmer Band 4	75 Mmf Var. Spec. Invar. Silver Plated	APC	5	B7175-16
C20	Antenna Trimmer Band 5	Same as C19			

Symbol	Function	Description	Mfr's Type No.	Mfr.	Bendix Number
CAPACITORS (Cont'd)					
C21	Antenna Trimmer Band 6	100 Mmf Var. Spec. Invar. Silver Plated	APC	5	B7175-17
C22	RF Primary Shunting Band 1	500 Mmf $\pm 10\%$, 500V DCW, Mica	1468 with XM262 Case	4	C56315-501 17296 ✓
C23	RF Primary Shunting Band 2	70 Mmf $\pm 5\%$ 500V DCW Mica	1468 with XM262 Case	4	C56314-700 17297 ✓
C24	RF Primary Shunting Band 3	15 Mmf $\pm 10\%$, 500V DCW Mica	1468 with XM262 Case	4	C56315-150 17298 ✓
C25	RF Coupling Band 4	Same as C12	.	.	.
C26	RF Coupling Band 5	Same as C14	.	.	.
C27	RF Coupling Band 6	Same as C14	.	.	.
C28	Antenna Coupling Band 5	Same as C12	.	.	.
C29	RF Trimmer Band 1	25 Mmf Var. Invar. Silver Plated	APC	5	B7175-13 17299 ✓
C30	RF Trimmer Band 2	Same as C29	.	.	.
C31	RF Trimmer Band 3	Same as C29	.	.	.
C32	RF Trimmer Band 4	Same as C16	.	.	.
C33	RF Trimmer Band 5	Same as C16	.	.	.
C34	RF Trimmer Band 6	Same as C16	.	.	.
C35	Osc. Trimmer Band 1	Same as C19	.	.	.
C36	Osc. Trimmer Band 2	Same as C16	.	.	.
C37	Osc. Trimmer Band 3	Same as C16	.	.	.
C38	Osc. Trimmer Band 4	Same as C29	.	.	.
C39	Osc. Trimmer Band 5	Same as C29	.	.	.
C40	Osc. Trimmer Band 6	Same as C29	.	.	.
C41	Osc. Padder Band 1	Same as C19	.	.	.
C42	Osc. Padder Band 2	Same as C21	.	.	.
C43	Osc. Padder Band 3	Same as C19	.	.	.
C44	Osc. Padder Band 4	Same as C19	.	.	.
C45	Osc. Padder Band 5	Same as C21	.	.	.
C46	Osc. Padder Band 6	Same as C21	.	.	.
C47	Osc. Padder Band 3	110 Mmf $\pm 2 \frac{1}{2}\%$, 500V DCW Mica	1467 with XM262 Case	4	B15530-37P 17754 ✓
C48	Osc. Padder Band 4	300 Mmf $\pm 2 \frac{1}{2}\%$, 500V DCW Mica	1467 with XM262 Case	4	B15530-16P 17755 ✓
C49	Osc. Padder Band 5	580 Mmf $\pm 2 \frac{1}{2}\%$, 500V DCW Mica	1467 with XM262 Case	4	B15530-38P 17757 ✓
C50	Osc. Padder Band 6	1110 Mmf $\pm 2 \frac{1}{2}\%$, 500V DCW Mica	1467 with XM262 Case	4	B15530-39P 17759 ✓
C51	V2 Grid Coupling	100 Mmf $\pm 10\%$, 500V DCW Mica	1468 with XM262 Case	4	C56315-101 17760 ✓
C52	Osc. Coupling	25 Mmf $\pm 10\%$, 500V DCW Mica	1468 with XM262 Case	4	C56315-250 17761 ✓
C54	1st IF Plate Trimmer				
C58	1st IF Grid Trimmer	110-150 Mmf Dual Var.	APC 2556	5	B7066 17762 ✓

Symbol	Function	Description	Mfr's. Type No.	Mfr.	Bendix Number
CAPACITORS (Cont'd)					
C59	2nd IF Plate Trimmer	Same as C54	.	.	.
C60	2nd IF Grid Trimmer		.	.	.
C61	CW Osc. Coupling	1.5 Mmf <u>+50%</u> Mica	P120K10	6	B7003-20M 17765
C62	3rd IF Plate Trimmer	Same as C54	.	.	.
C63	3rd IF Grid Trimmer		.	.	.
C64	3rd IF Coupling	Same as C61	.	.	.
C65	V6 Diode Load Bypass	150 Mmf <u>+10%</u> , 500V DCW Mica	1468 with XM262 Case	4	C56315-151 1776
C67	V6 Grid Bypass	Same as C65	.	.	.
C68	V6 Plate Bypass	230 Mmf <u>+10%</u> , 500V DCW Mica	1468 with XM262 Case	4	C56315-251
C69	V7 Grid Coupling	.01 Mfd <u>+10%</u> , 500V DCW Mica	1467 with XM262 Case	4	C56312-108 17766
C70	CW Osc. Cathode Return Bypass	Same as C69	.	.	.
C71	CW Osc. Tuning	Same as C19	.	.	.
C72	CW Osc. Fixed Tuning	500 Mmf <u>+3%</u> Mica	2R (red case)	3	B15310-10F
C73	CW Osc. Grid	100 Mmf <u>+10%</u> Mica	.	6	B7003-7F
C80	Trailing Wire Antenna	Same as C65	.	.	.
C81	Antenna Series Trimmer	100 Mmf Var. Brass Plates	APC	5	A10620-1
C82	Antenna Series Coupling	Same as C65	.	.	.
C83	Shunt, Sec. T1	Same as C69	.	.	.

INDICATOR LAMP

DL1	Dial Light	14-16 V Bayonet Base	T- 3 1/4	10	A13244
-----	------------	----------------------	----------	----	--------

INDUCTORS

L1	Antenna Band 1	.	.	1	AB11864
L2	Antenna Band 2	.	.	1	AB11865
L3	Antenna Band 3	.	.	1	AB11866
L4	Antenna Band 4	.	.	1	AB6772
L5	Antenna Band 5,	.	.	1	AB6773
L6	Antenna Band 6	.	.	1	AB6774
L7	RF Band 1	.	.	1	AB6776
L8	RF Band 2	.	.	1	AB6777
L9	RF Band 3	.	.	1	AB6778
L10	RF Band 4	.	.	1	AB6779
L11	RF Band 5	.	.	1	AB6780
L12	RF Band 6	.	.	1	AB6781
L13	Heterodyne Osc. Band 1	.	.	1	AB6783-1
L14	Heterodyne Osc. Band 2	.	.	1	AB6783-2
L15	Heterodyne Osc. Band 3	.	.	1	AB6783-3
L16	Heterodyne Osc. Band 4	.	.	1	AB11676
L17	Heterodyne Osc. Band 5	.	.	1	AB6784

Symbol	Function	Description	Mfr's. Type No.	Mfr.	Bendix Number
INDUCTORS (Cont'd)					
L18	Heterodyne Osc. Band 6	.	.	1	AB6785
L19	IF Filter *FL1 Primary	.	.	1	A27818
L22	IF Filter *FL1 Secondary	.	.	1	A27818
L23	IF Transformer *FL2 Pri.	Same as L19-22	.	.	.
L24	IF Transformer *FL2 Sec.
L25	IF Transformer *FL3 Pri.	Same as L19-22	.	.	.
L26	IF Transformer *FL3 Sec.
L27	CW Osc.	.	17789✓	1	A27822-1
PLUGS					
PL1	For Remote Control	8 Contact Plug Board	.	1	AA296-1
PL3	Power Cable, Dynamotor	6 Contact Plug Board	.	1	AA309-1
CCF1	For Remote Control	8 Prong, 90° Female. 655 wire hole	.	1	AA12468-1
CCF3	Power Cable, Dynamotor	6 Prong, 90° Female .550 wire hole	.	1	AA11845-1
RECEPTACLES					
J1	Local Telephone Jack	Single Circuit	TC-60	16	A3098
J4	Test Jack - Ground	Tip Jack	419A	8	A4509
J5	Test Jack - Audio	Same as J4	.	.	.
J6	Test Jack - A+	Same as J4	.	.	.
J7	Test Jack - B+	Same as J4	.	.	.
RESISTORS					
R1	V1 Grid Decoupling	50,000 ohms, 1/4W, ±10%, Ceramic	17770✓	6	A18151-503
R2	V1 Cathode Initial Bias	500 ohms, 1/4W, ±10%, Ceramic	17771✓	6	A18151-501
R3	V1 Screen Decoupling	5,000 ohms, 1/4W, ±10%, Ceramic	17773✓	6	A18151-502
R4	V1 Plate Decoupling	1,000 ohms, 1/4W, ±10%, Ceramic	17774✓	6	A18151-102
R5	V3 Grid Decoupling	Same as R1	.	.	.
R6	V2 Grid Leak	Same as R1	.	.	.
R7	V3 Grid Return	Same as R1	.	.	.
R8	V2 Screen Decoupling	25,000 ohms, 1/4W, ±10%, Ceramic	17775	6	A18151-253
R9	V2 Plate Decoupling	Same as R3	.	.	.
R10	V2 Screen Decoupling	Same as R1	.	.	.
R11	V3 Cathode Initial Bias	Same as R4	.	.	.
R12	V3 Screen Decoupling	Same as R8	.	.	.
R13	V3 Plate Decoupling	Same as R4	.	.	.
R14	V4 Grid Decoupling	Same as R1	.	.	.
R15	V4 Cathode Initial Bias	Same as R2	.	.	.
R16	V4 Screen Decoupling	Same as R3	.	.	.
R17	V4 Plate Decoupling	Same as R4	.	.	.
R18	V5 Cathode Initial Bias	Same as R2	.	.	.

Symbol	Function	Description	Mfr's. Type No.	Mfr.	Bendix Number	
RESISTORS (Cont'd)						
R19	V5 Screen Decoupling	Same as R3	.	.	.	
R20	V5 Plate Decoupling	Same as R4	.	.	.	
R21	V1, V4, V5 Screen Voltage Divider	20,000 ohms, 2W $\pm 5\%$, Ceramic	.	7	A4516-1 (17	
R22						
R23	V6 Diode Load	700,000 ohms, 1/4W, $\pm 10\%$, Ceramic	. 17778 ✓	6	A18151-700	
R24	V6 Diode Load	300,000 ohms, 1/4W, $\pm 10\%$, Ceramic	. 17779 ✓	6	A18151-304	
R26	V6 Plate Load	Same as R1	.	.	.	
R29	V6 Diode Filter	1 Megohm 1/4W, $\pm 10\%$, Ceramic	. 17780 ✓	6	A18151-105	
R30	AVC Overload Limiting	Same as R1	.	.	.	
R32	V8 Plate Bleeder	100,000 ohms, 1/4W, $\pm 10\%$, Ceramic	. 17781 ✓	6	A18151-104	
R33	V8 Plate Bleeder	500,000 ohms, 1/4W, $\pm 10\%$, Ceramic	. 17782 ✓	6	A18151-504	
R34	V8 Plate Bleeder	Same as R33	.	.	.	
R35	V8 Grid Leak	Same as R32	.	.	.	
R37	V7 Grid Return	Same as R29	.	.	.	
R38	V7 Cathode Bias	750 ohms, 1/2W, $\pm 10\%$, Ceramic	. 17783 ✓	6	A18150-751	
R39	Dual Volume Sensitivity Control	10,000 ohms, maximum Curve E	} 17784 ✓	7	A27811	
R40		2,000 ohms, maximum Curve B				
R43.1	Filament Current Compensating	126 ohms, $\pm 5\%$	} 17786 ✓	MW-2	7	QB15190-3
R43.2		Plus 63 ohms, $\pm 5\%$				
R44.1	Dial Light Dropping	120 ohms, $\pm 5\%$	} 17788 ✓	MW-2	7	QB15190-1
R44.2		Plus 120 ohms, $\pm 5\%$				
R45	Audio Load	Same as R2	.	6	.	
R47	Static Drain	Same as R33	.	6	.	
SWITCHES						
S1	Antenna Primary Selector	6 Position - 1 Pole	RN	8	A26020	
S2	Antenna Grid Selector	Same as S1	.	.	.	
S3	RF Primary Selector	Same as S1	.	.	.	
S4	RF Grid Selector	Same as S1	.	.	.	
S5	Osc. Tuning Condenser	Same as S1	.	.	.	
S6	Osc. Coil Selector	Same as S1	.	.	.	
S7	Osc. Cathode	Same as S1	.	.	.	
S8	Local AVC On-Off	DPDT 7/8" Shank	.	14	A3142-1	
S9	Local-remote	4 PDT	3100J	8	A4506	
S10	Local CW On-Off	SPDT, 7/8" Shank	.	14	A3141-1	

Symbol	Function	Description	Mfr's. Type No.	Mfr.	Bendix Number
SWITCHES (Cont'd)					
S11	Local Power On-Off	Same as S10	.	.	.
S15	Antenna Selector	Two Pole Three Position	.	8	A3528
TRANSFORMER					
T1	Audio Output	260 ohms, Impedance 17794✓	.	11	QE15206-1
VACUUM TUBES					
V1	RF Amplifier	Super-Control Pentode	6K7G	12	.
V2	Heterodyne Oscillator	Same as V1	.	.	.
V3	Converter	Pentagrid Mixer	6L7G	12	.
V4	1st IF Amplifier	Same as V1	.	.	.
V5	2nd IF Amplifier	Same as V1	.	.	.
V6	2nd Detector	Duplex-Diode Triode	6R7G	12	.
V7	Audio Output	Power Amplifier Pentode	6K6G	12	.
V8	CW Oscillator	Same as V1	.	.	.

6-2. TYPE RA-II RECEIVER

The RA-II Receiver uses the same parts as an RA-1B except for the following:

CAPACITOR

C83	Shunt, Sec. T1	.001 Mfd $\pm 10\%$ 500V DCW Mica	1467	4	C56312-102
-----	----------------	-----------------------------------	------	---	------------

RESISTORS

R39	Local, dual volume	Rear, 10,000 ohms, Curve E	Dual Type CP	7	A2782
R40	Sensitivity control	Front, 25,000 ohms, Curve B	.	.	.
R45	Audio load	4000 ohms, 1/4W $\pm 10\%$ Ceramic	.	6	A18151-402

TRANSFORMER

T1	Audio Output Transformer	3500 ohms, Impedance 15854✓	Special	11	A27010
----	--------------------------	-----------------------------	---------	----	--------

6-3. TYPE RA-1J RECEIVER

The RA-1J Receiver uses the same parts as an RA-1B except for the following:

CAPACITORS

C15	Antenna Coupling Band 4	5 Mmf $\pm 10\%$, 500V DCW Mica	1468 with XM262 case	4	C56315-050
✓C48	Heterodyne Osc Padder Band 4	420 Mmf ± 2 1/2%, 500V DCW Mica	1467 with XM262 case	4	B15530-47P
✓C49	Heterodyne Osc Padder Band 5	810 Mmf ± 2 1/2%, 500V DCW Mica	1467 with XM262 case	4	B15530-48P
✓C50	Heterodyne Osc Padder Band 6	1420 Mmf ± 2 1/2%, 500V DCW Mica	1467 with XM262 case	4	B15530-49P

Capacitors C25, C26, C27 and C28 not used.

INDUCTORS

L4	Antenna Band 4	.	.	1	B13688
L5	Antenna Band 5	.	.	1	B13689

Symbol	Function	Description	Mfr's. Type No.	Mfr.	Bendix Number
INDUCTORS (Cont'd)					
L6	Antenna Band 6	.	.	1	B13690
L10	RF Band 4	.	.	1	B13694
L11	RF Band 5	.	.	1	B13695
L12	RF Band 6	.	.	1	B13696
L16	Heterodyne Osc Band 4	.	.	1	B13700
L17	Heterodyne Osc Band 5	.	.	1	B13701
L18	Heterodyne Osc Band 6	.	.	1	B13702

RESISTORS

R2	V1 Cathode Initial Bias	300 ohms, 1/4W $\pm 10\%$ Ceramic	.	6	A18151-301
R8	V2 Screen Decoupling	20,000 ohms, 1/4W $\pm 10\%$ Ceramic	.	6	A18151-203
R9	V2 Plate Decoupling	Same as R4 in RA-1B	.	.	.
R11	V3 Cathode Initial Bias	Same as R2 in RA-1B	.	.	.

VACUUM TUBE

V2	Heterodyne Oscillator	Triple - Grid Pentode	6J7G	12	.
----	-----------------------	-----------------------	------	----	---

6-4. TYPE MR-1B REMOTE CONTROL UNIT

INDICATOR LAMP

DL2	Dial Lamp	Same as DL1	.	.	.
-----	-----------	-------------	---	---	---

PLUGS

PL2	Remote Control Cable	Same as PL1	.	.	.
CCF2	Remote Control Cable	8 Prong, Straight, Female .655 Wire Hole	.	1	AA12443

RECEPTACLES

J2	Telephone Jack	Same as J1	.	.	.
J3	Telephone Jack	Same as J1	.	.	.

RESISTORS

R41	Dual Volume, Sensitivity	Same as R39-R40	.	.	.
R42	Control		.	.	.
R46	Audio Load	Same as R45	.	.	.

SWITCHES

S12	AVC On-Off	Same as S8	.	.	.
S13	CW On-Off	Same as S10	.	.	.
S14	Power On-Off	Same as S10	.	.	.

6-5. TYPE MR-1I REMOTE CONTROL UNIT

The Mr-1I Remote Control Unit uses the same parts as an MR-1B except for the following:

RESISTORS

R41	Dual Volume, Sensitivity		.	.	.
R42	Control	Same as R39-R40 in RA-1I	.	.	.
R46	Audio Load	Same as R45 in RA-1I	.	.	.

Symbol	Function	Description	Mfr's. Type No.	Mfr.	Bendix Number
--------	----------	-------------	--------------------	------	------------------

6-6. TYPE MR-1J REMOTE CONTROL UNIT

The MR-1J Remote Control Unit uses the same electrical parts as the MR-1B.

6-7. TYPE MP-5B POWER SUPPLY

CAPACITORS

C74	LV Filter				
C75	HV Filter	3 x .8 Mfd 500V DCW, Paper	17769	VC-368	3 A4532
C76	HV Filter				
C77	LV Noise Filter	Same as C69	.	.	.
C78	LV Noise Filter	Same as C69	.	.	.
C79	Dynamotor Brush Input	Same as C69	.	.	.

PLUGS

CCF4	Power Supply Cable	6 Prong, Straight, Female	.	1	AA11846
CCF7	Battery Supply Cable	2 Prong, Straight	.	1	AA12467-1

DYNAMOTORS

DYN	Power Supply	14V, 3A Input; 230V, .1A output	PS150	15853 ✓ 18	QE10309
.	LV Positive Brush	.	.	18	B15512
.	LV Negative Brush	.	.	18	B15513
.	HV Positive Brush	.	.	18	B15514
.	HV Negative Brush	.	.	18	B15515

FUSE

F1	Dynamotor Input	10A, 25V	3AG-1081	17	B3535-6
----	-----------------	----------	----------	----	---------

RELAY

H1	Dynamotor Control	2 Pole 8-16V DC, Normally Open	17799 ✓ 1204	15	B4894-1
----	-------------------	--------------------------------	--------------	----	---------

INDUCTORS

L28	RF Input Choke	.	17790 ✓	1	AB655
L29	HV Filter Choke	6 Henries .080A, 160 ohms DC Resistance	17791 ✓ 3236A	9	A13111-1

RECEPTACLES

PL4	Receiver Power Supply	Same as PL3	.	.	.
PL5	Direction Finder Supply	5 Contact Plug Board	.	1	AA306-1
PL6	Interphone Power Supply	Same as PL5	.	.	.
PL7	Battery Supply	2 Prong Plug Board	.	1	AA310-1

6-8. TYPE MP-5A24 POWER SUPPLY

The Type MP-5A24 Power Supply uses the same parts as an MP-5B except for the following:

DYNAMOTOR

DYN	Power Supply	28V, 1.55A Input; 230V, .1A output	PS150	18	QE10309-1
-----	--------------	------------------------------------	-------	----	-----------

FUSE

F1	Dynamotor Output	1/8A, 500V	3AG-1044	17	B3532-21
----	------------------	------------	----------	----	----------

RELAY

H1	Dynamotor Control	16-30V DC, Normally Open	1204	15	B4894-1
----	-------------------	--------------------------	------	----	---------

7. ADDRESSES OF MANUFACTURERS

1. Bendix Radio Corp.,
920 E. Fort Avenue,
Baltimore, Maryland.
2. Radio Condenser Co.,
Camden, N. J.
3. Cornell-Dubilier Electric Corp.,
1006 Hamilton Blvd.,
South Plainfield, N. J.
4. Aerovox Corp.,
New Bedford, Mass.
5. Hammarlund Mfg. Co., Inc.,
424 West 33rd Street,
New York, N. Y.
6. Erie Resistor Co.,
644 W. 12th Street,
Erie, Pa.
7. International Resistor Corp.,
401 N. Broad Street,
Philadelphia, Pa.
8. Yaxley Mfg. Co.,
Div. of P. R. Mallory Co., Inc.,
3029 E. Washington Street,
Indianapolis, Indiana.
9. Chicago Transformer Co.,
3501 Addison Street,
Chicago, Illinois.
10. General Electric Co.,
Nela Park,
Cleveland, Ohio.
11. Raytheon Mfg. Co.,
190 Willow Street,
Waltham, Mass.
12. R.C.A. Radiotron Div.,
R.C.A. Mfg. Co., Inc.,
401 Bergen Street,
Harrison, N. J.
13. A. J. Ulmer,
90 West Broadway,
New York, N. Y.
14. Hart & Hegeman Division,
Arrow-Hart & Hegeman Electric Co.,
3201 Arch Street,
Philadelphia, Pa.
15. Leach Relay Co.,
5915 Avalon Blvd.,
Los Angeles, Calif.
16. Telephonics Corp.,
350 W. 35th Street,
New York, N. Y.
17. Littelfuse, Inc.,
4757 Ravenswood Avenue,
Chicago, Illinois.
18. Pioneer Gen-E-Motor Corp.,
466 W. Superior Street,
Chicago, Illinois.

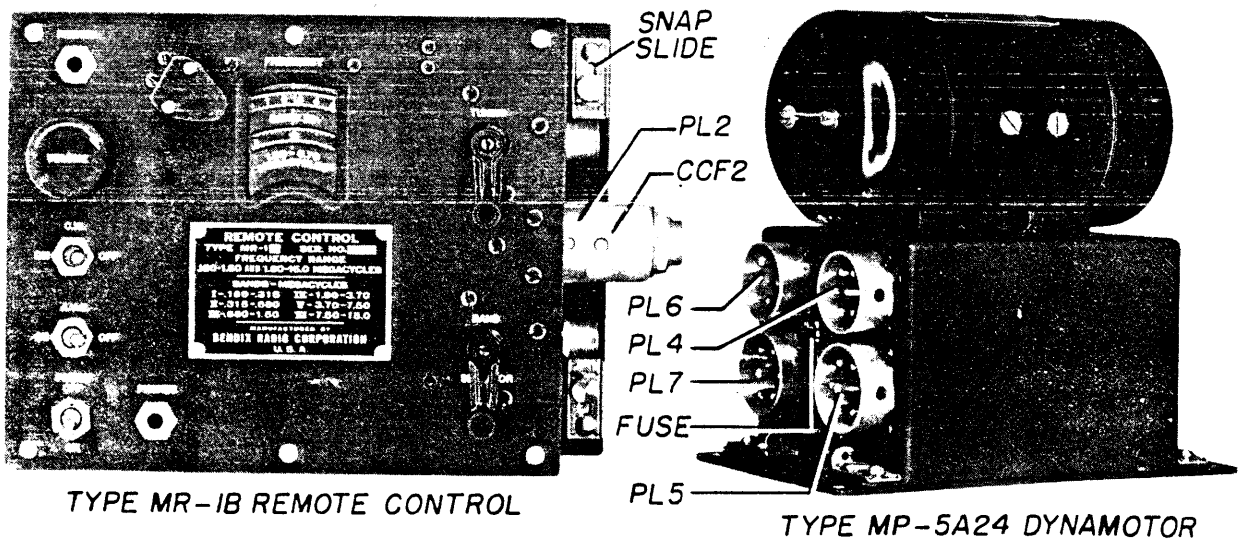
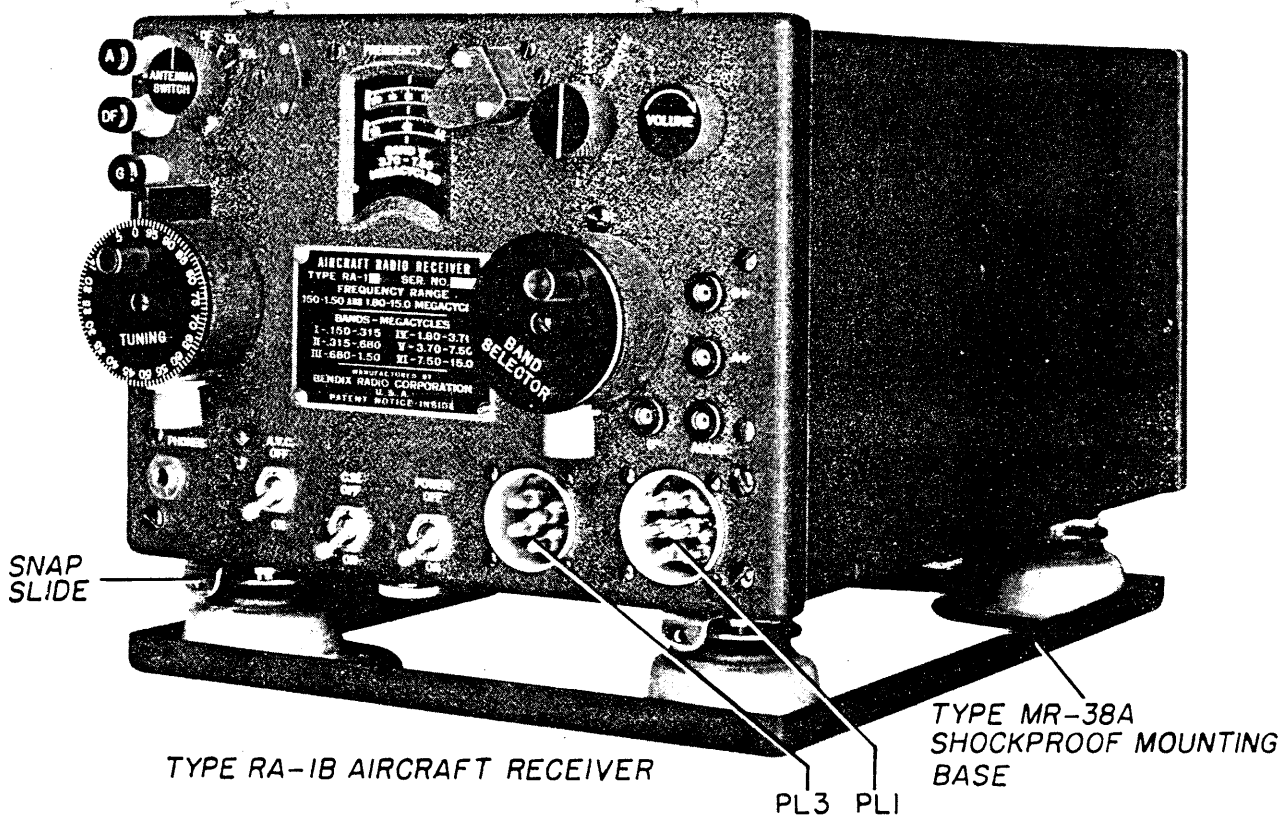

FIG. 1—TYPE RA-1B AIRCRAFT RADIO RECEIVER EQUIPMENT

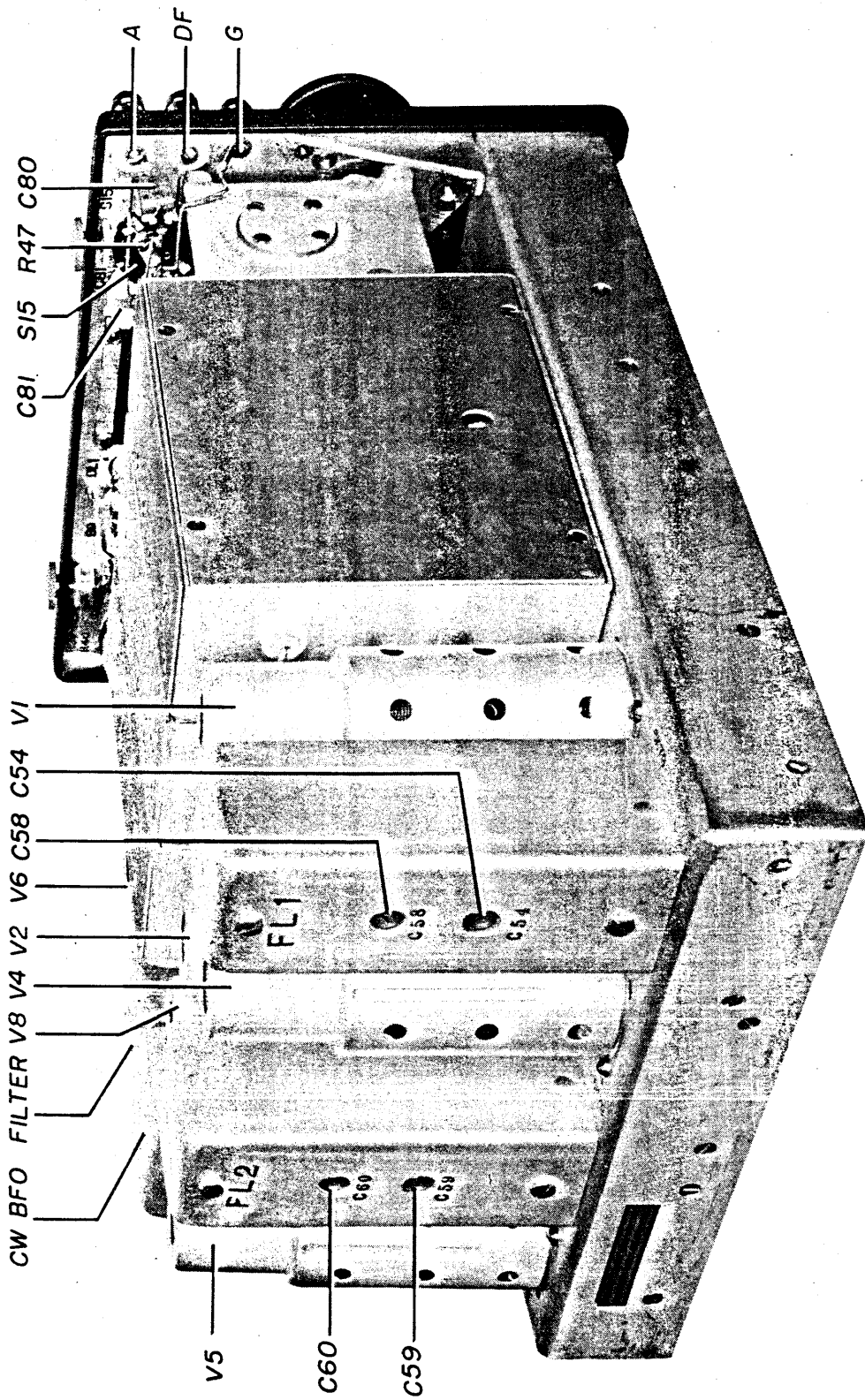

FIG. 2-TYPE RA-1B AIRCRAFT RECEIVER (REAR OBLIQUE VIEW)

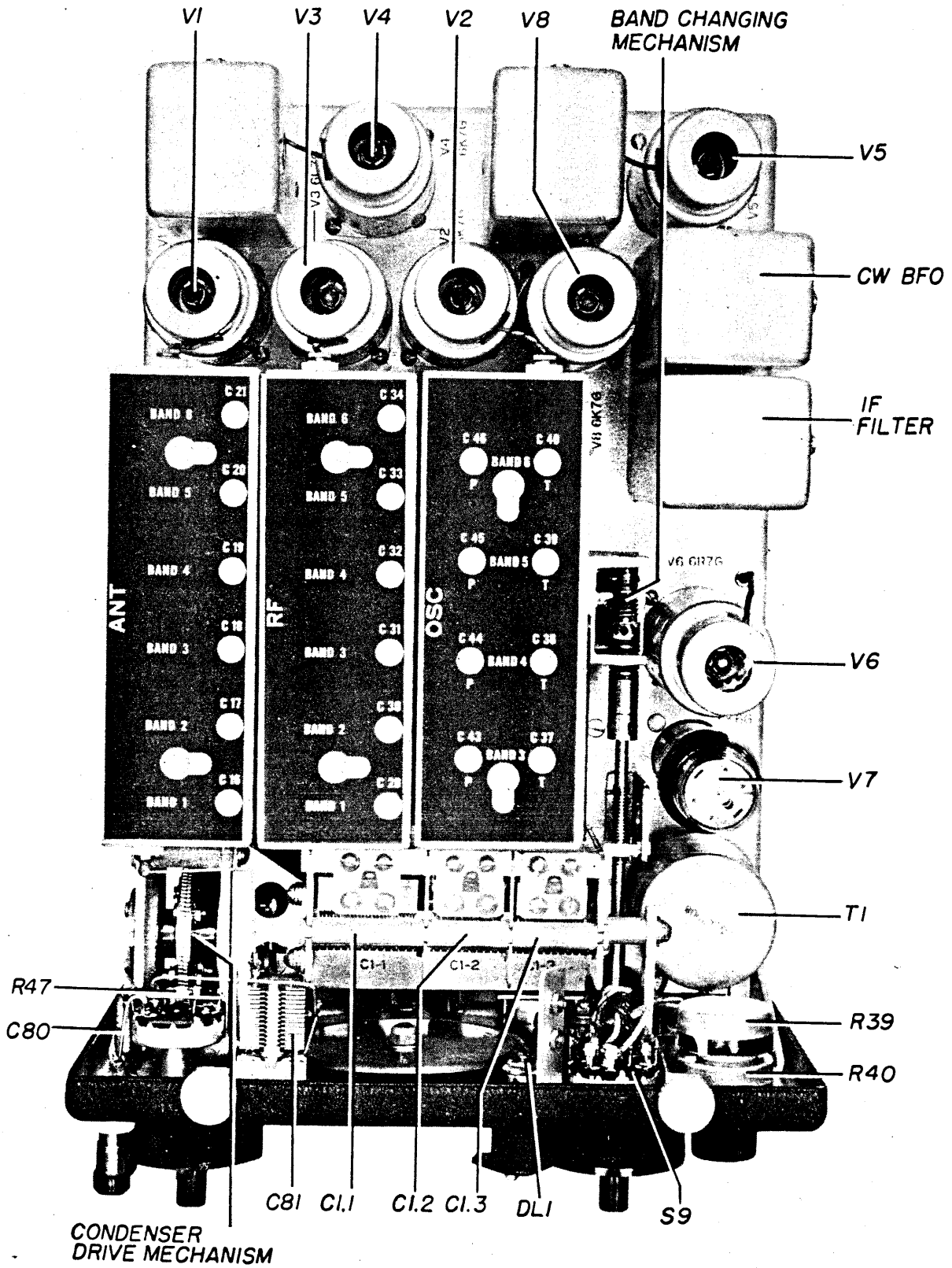

FIG.3-TYPE RA-1B AIRCRAFT RECEIVER (TOP VIEW)

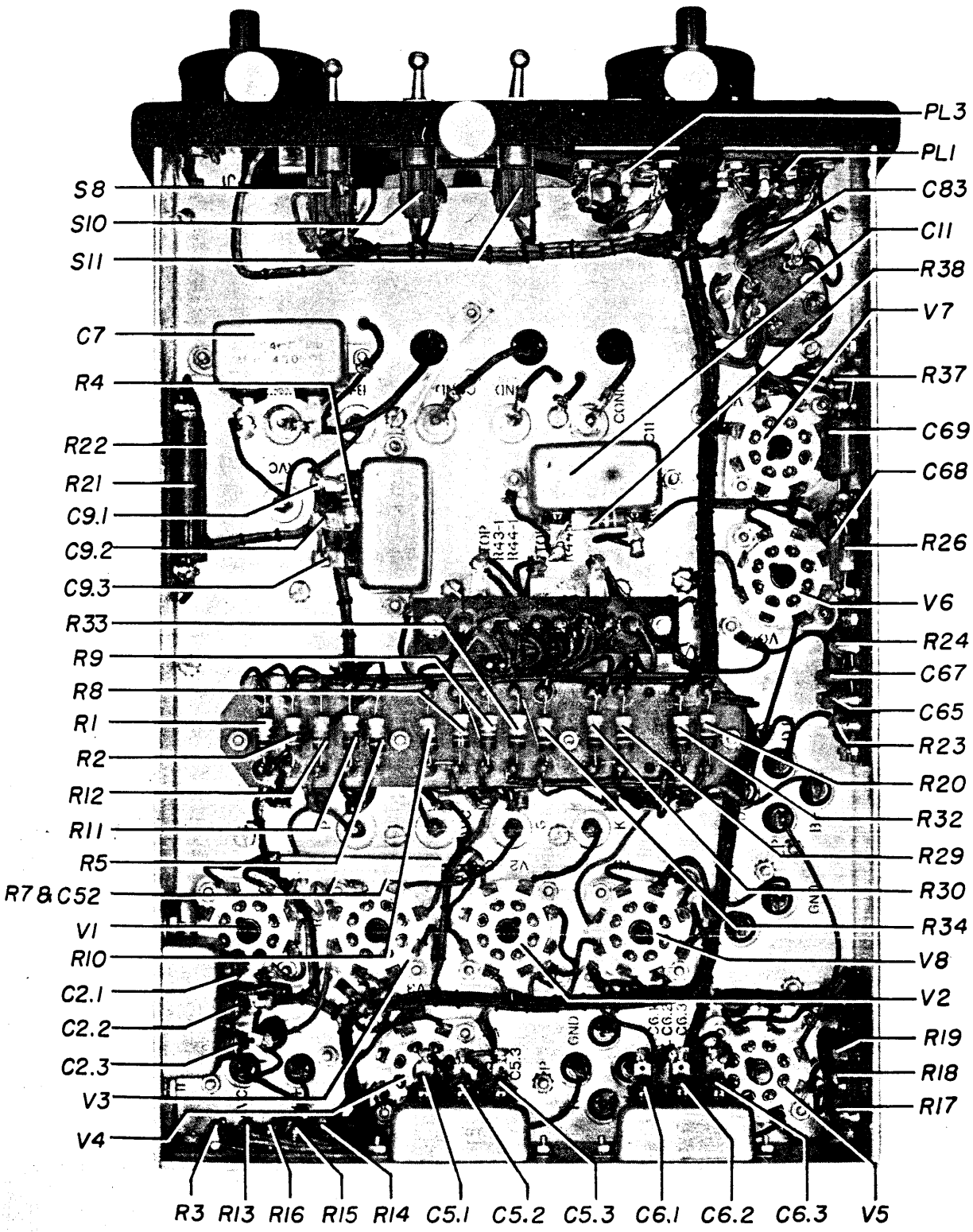

FIG. 4 - TYPE RA-1B AIRCRAFT RECEIVER (BOTTOM VIEW)

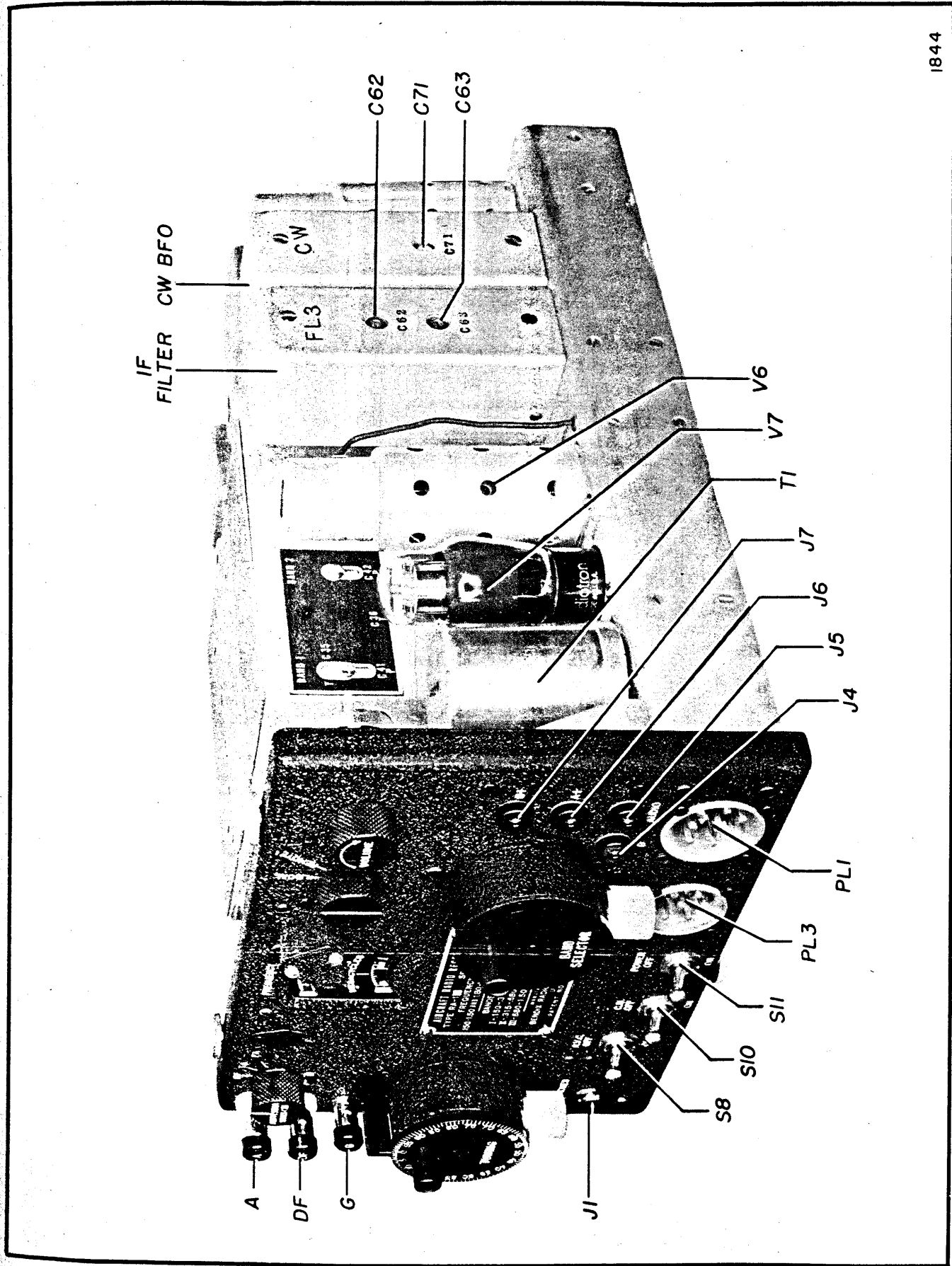

FIG.5-TYPE RA-1B AIRCRAFT RECEIVER (FRONT OBLIQUE VIEW)

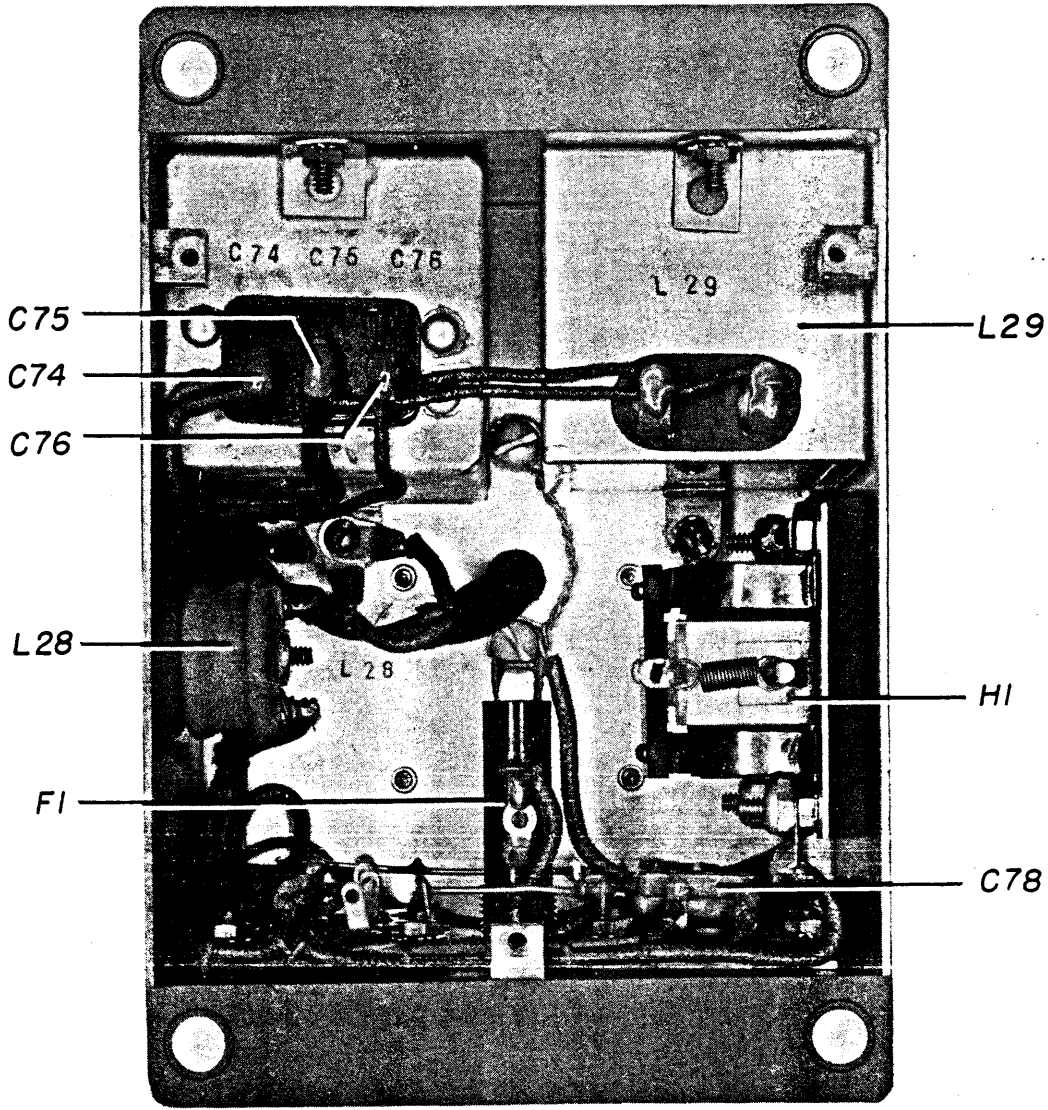

FIG. 6- TYPE MP-5B OR MP-5A24 DYNAMOTOR FILTER UNIT

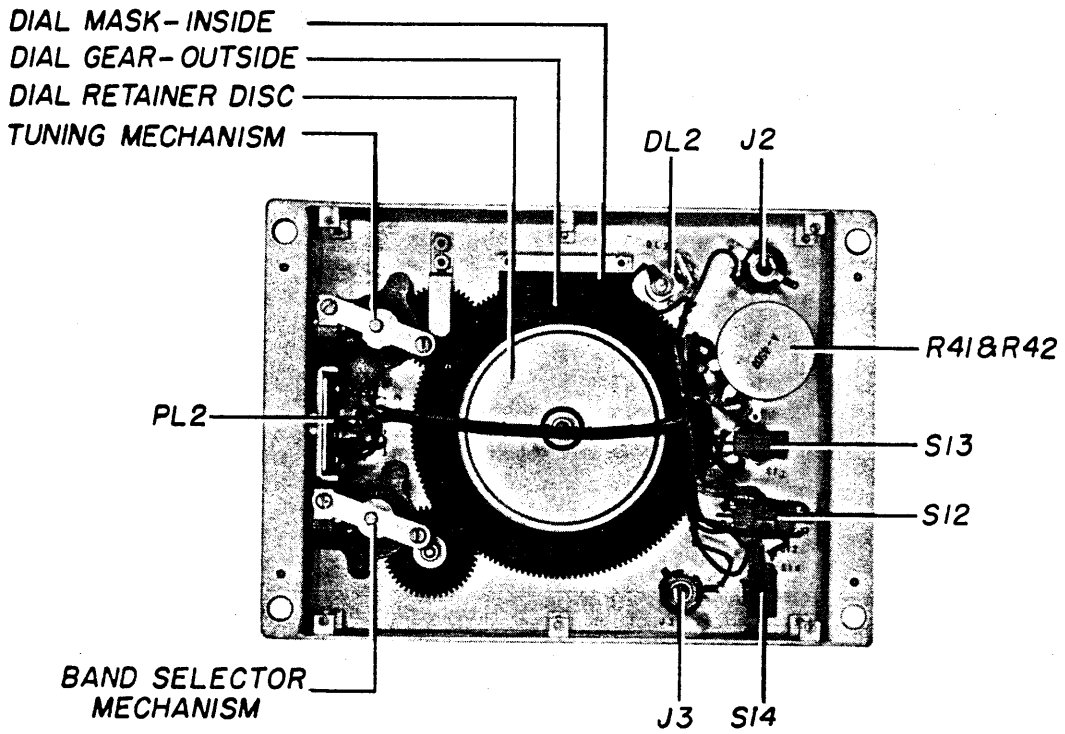
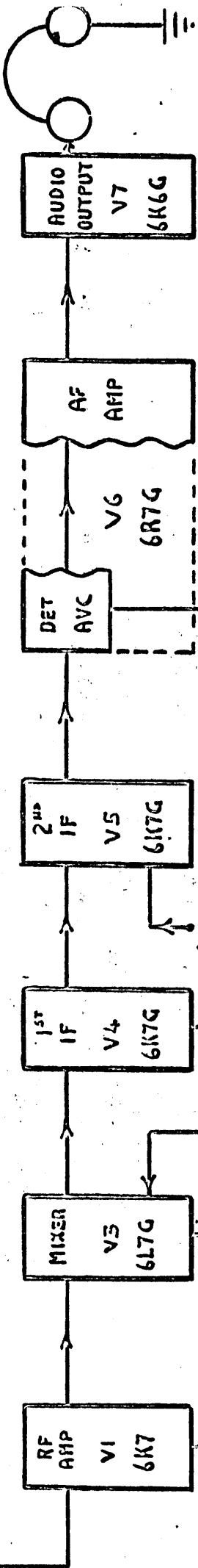
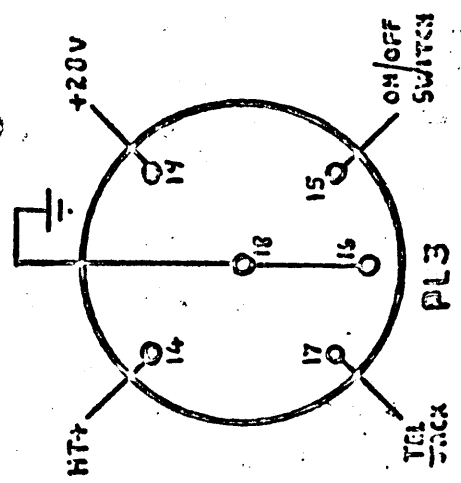
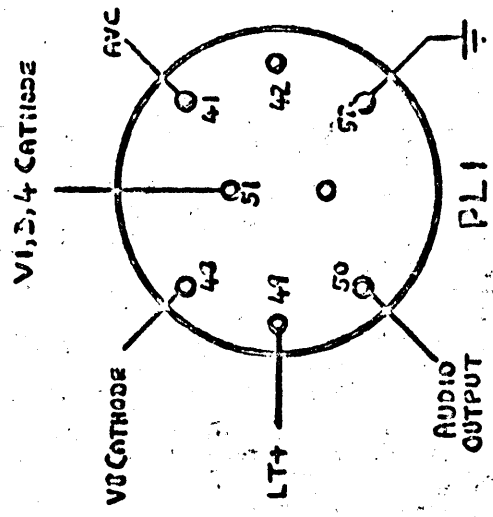

FIG.7- TYPE MR - 1B REMOTE CONTROL UNIT



CON 749 ALL TYPES AUX. RX. RAIB-J



DRAWN BY: [initials]
CHECKED BY: [initials]

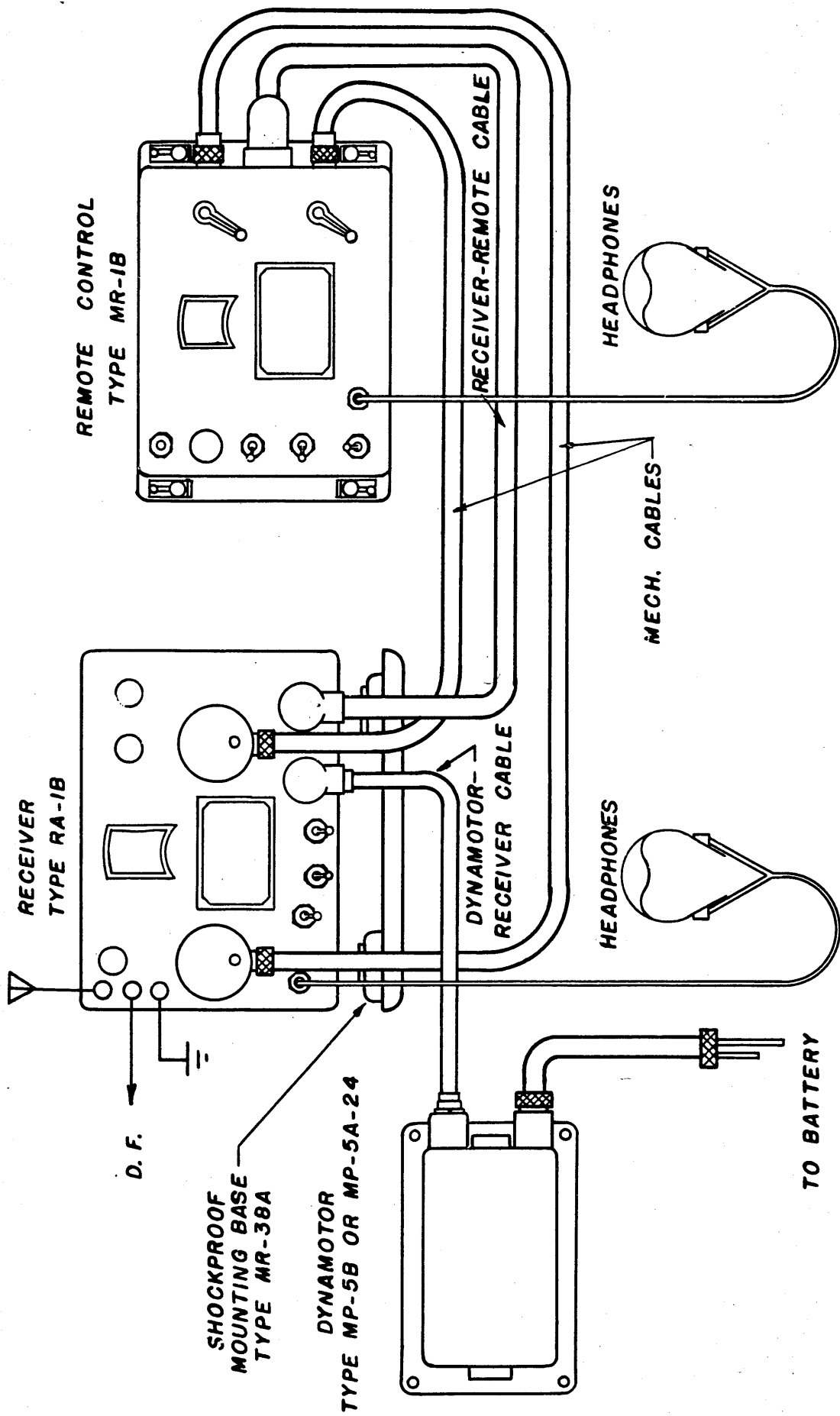

FIG. 8 DIAGRAM OF EXTERNAL CONNECTIONS

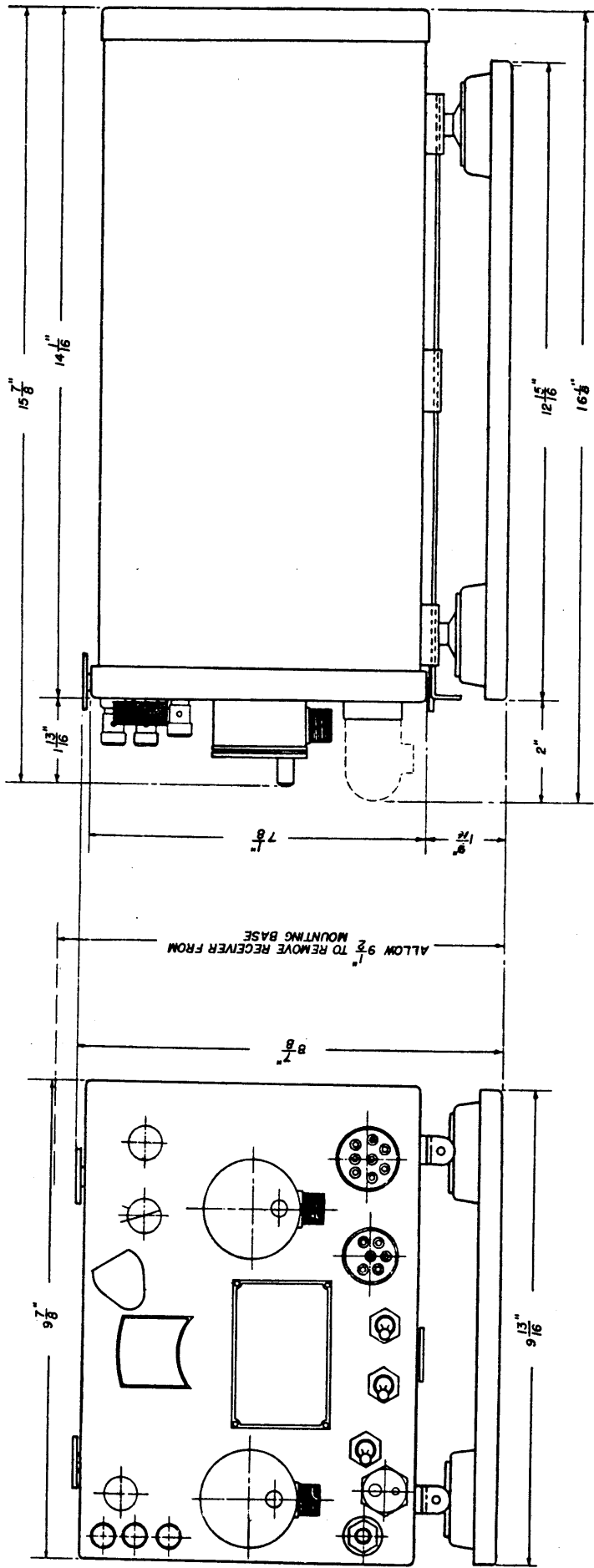

FIG. 9 - TYPE RA-1B RECEIVER UNIT OUTLINE DRAWING

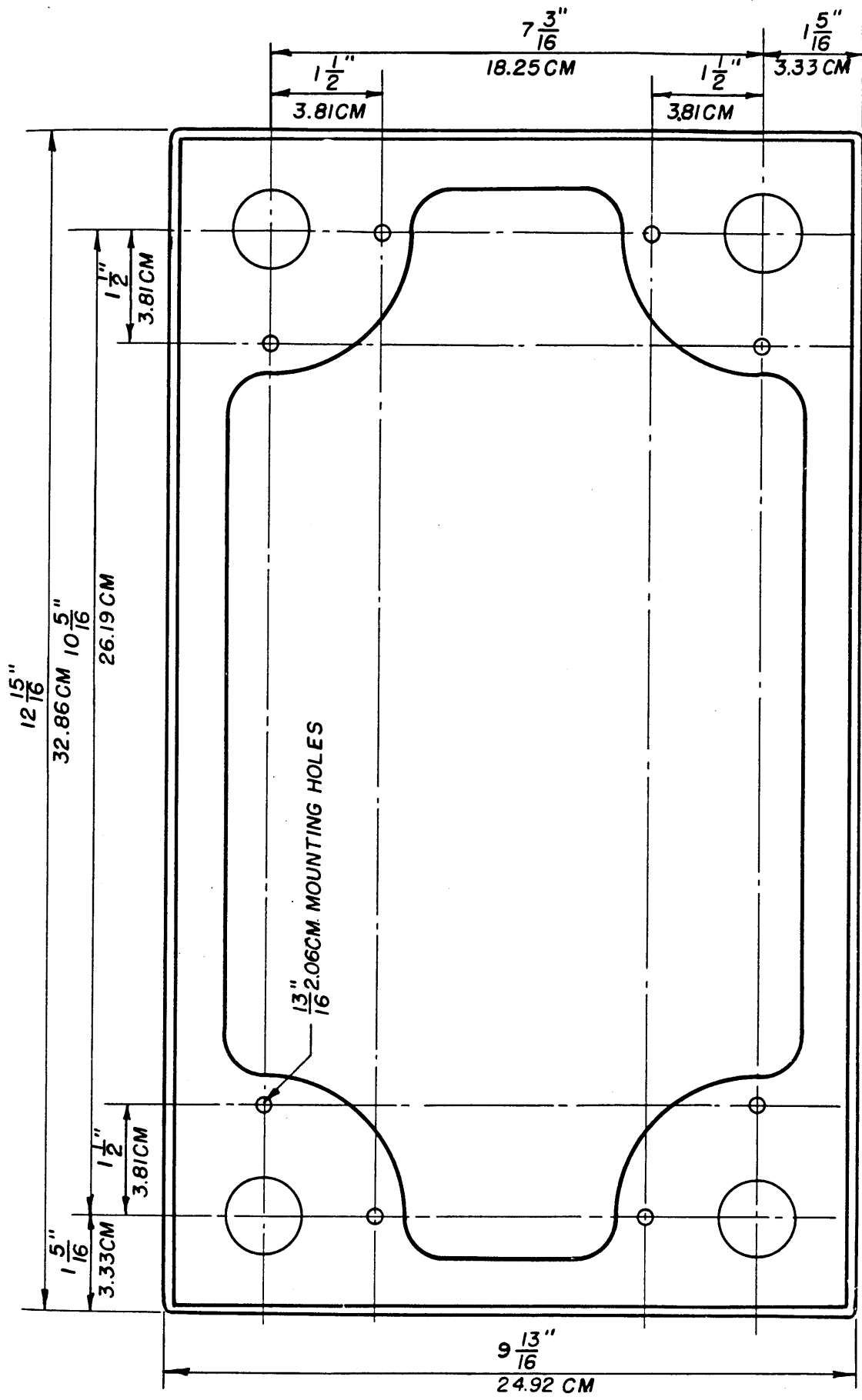

FIG.10-TYPE MR-38A SHOCK MOUNTING OUTLINE DRAWING

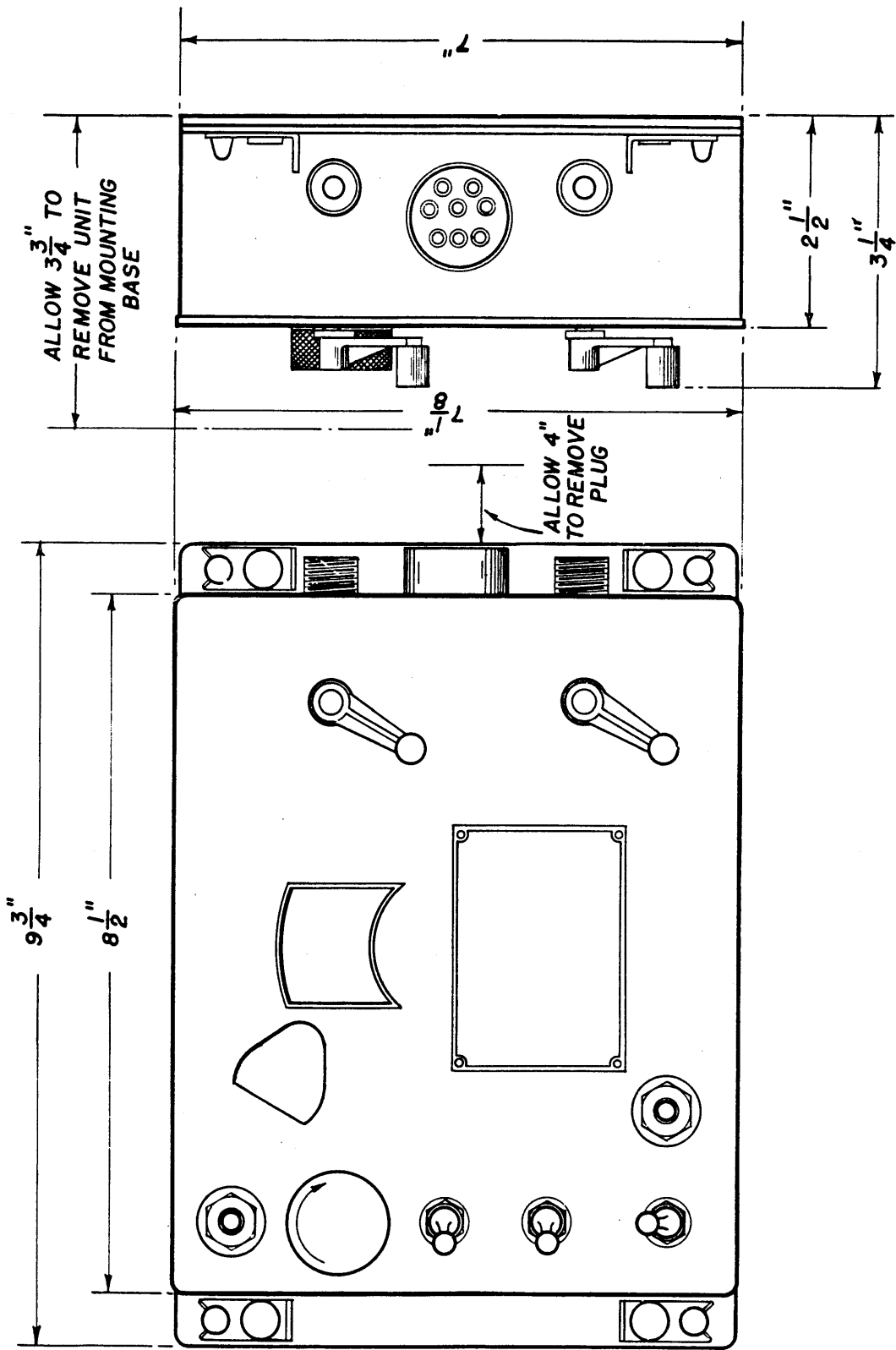

FIG.11-TYPE MR-IB REMOTE CONTROL UNIT OUTLINE DRAWING

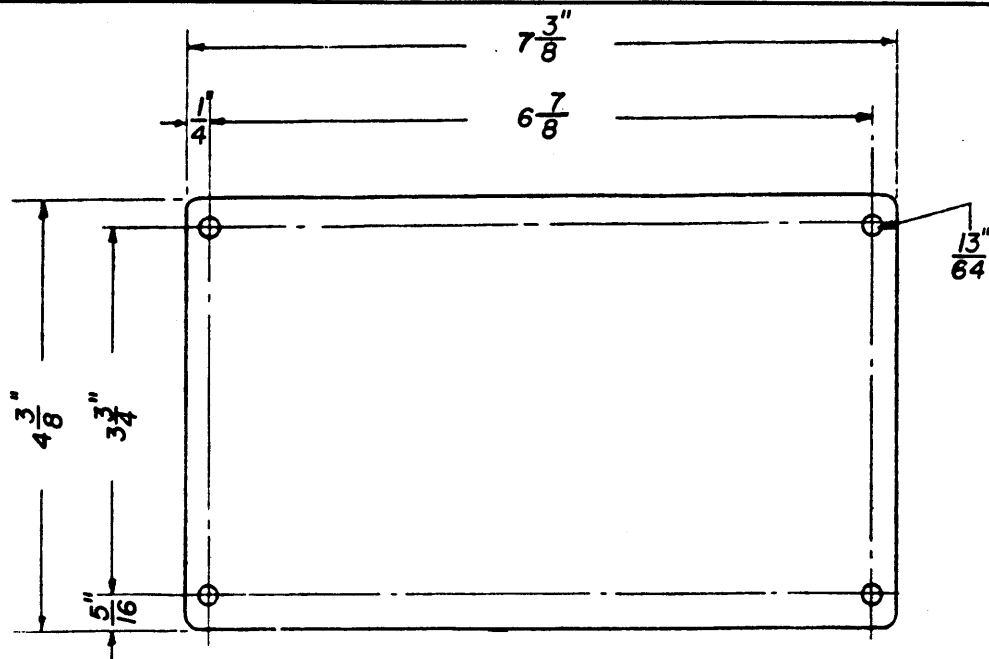

FIG.12 DYNAMOTOR BASE PLATE OUTLINE DIMENSIONS

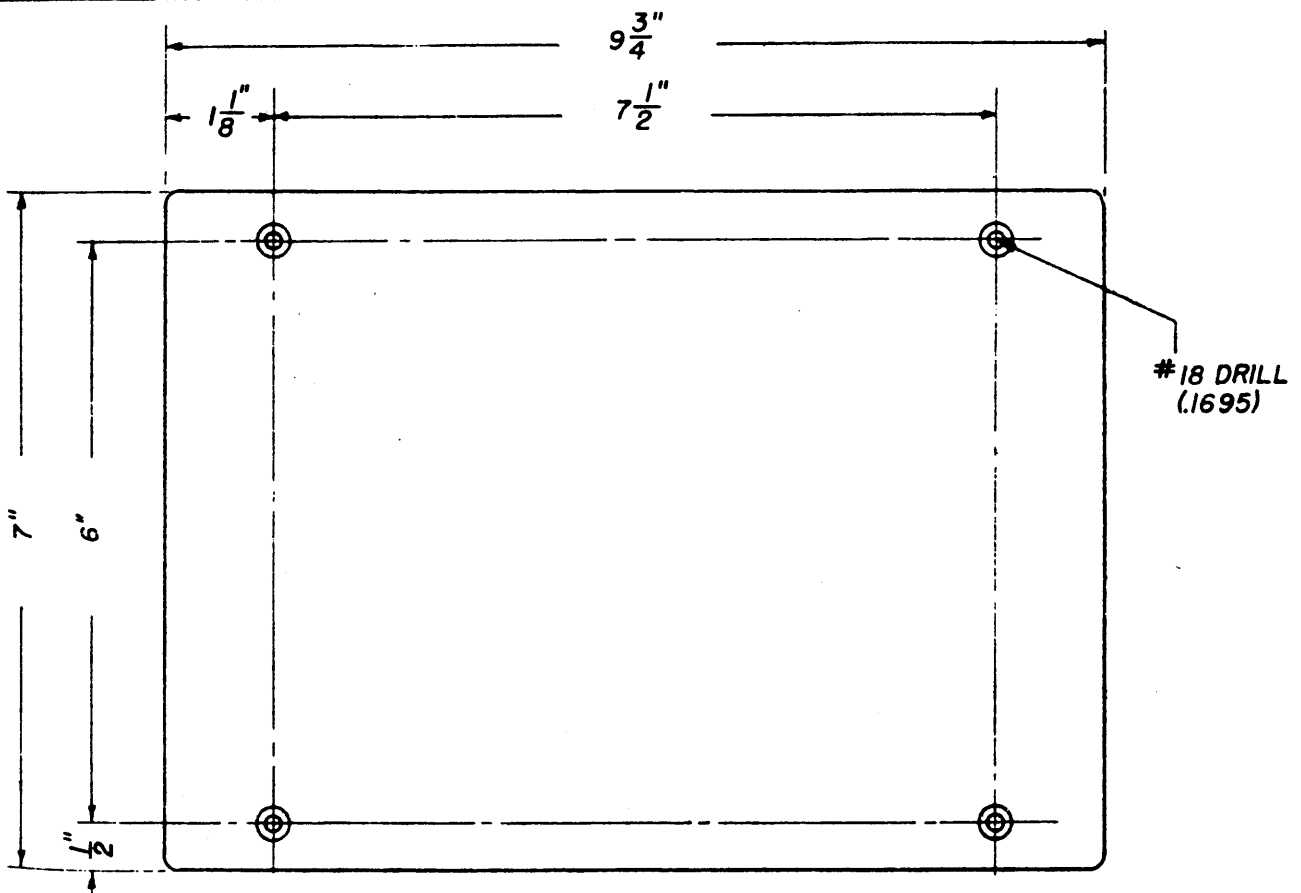

FIG.13 REMOTE CONTROL BASE PLATE OUTLINE DIMENSIONS

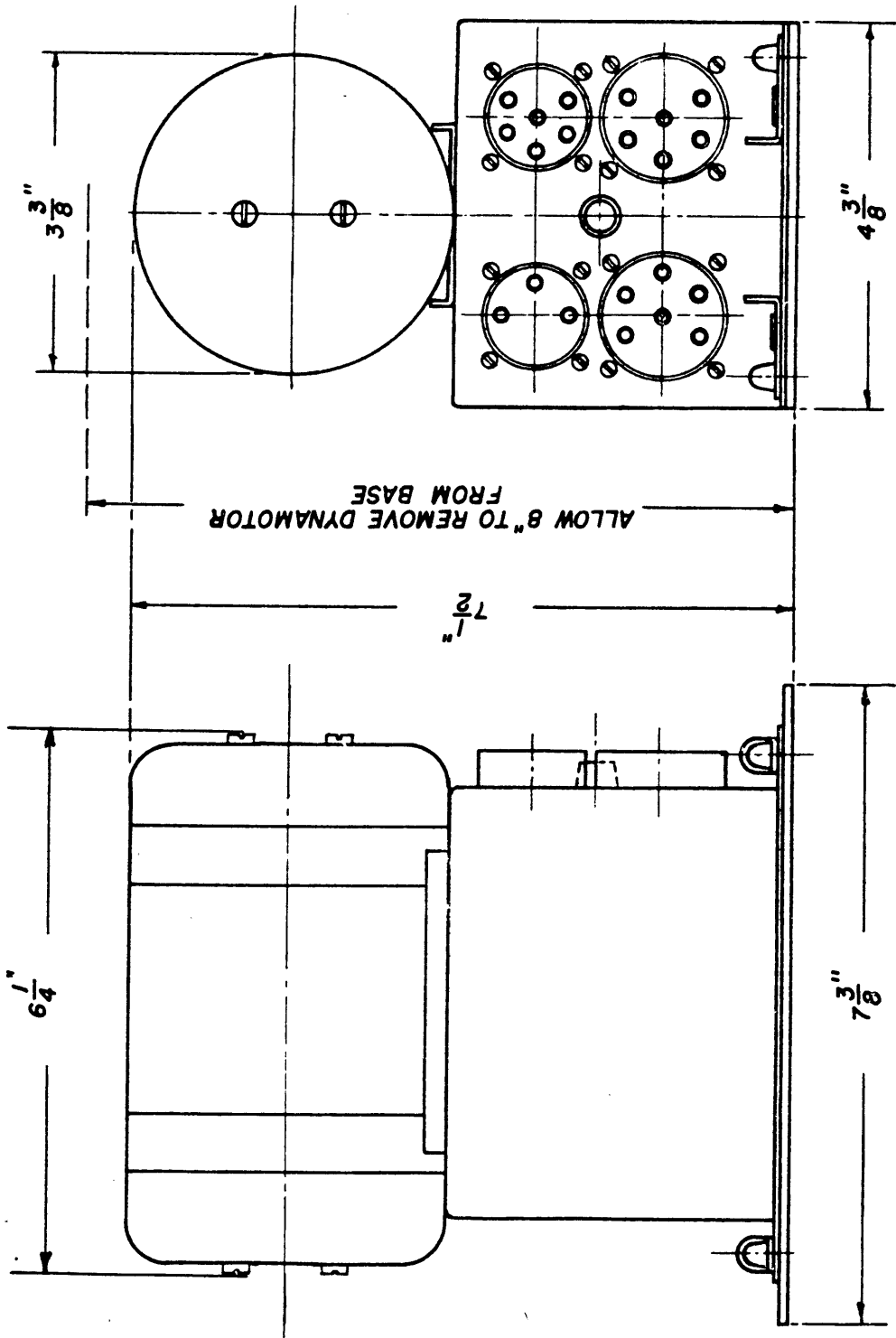
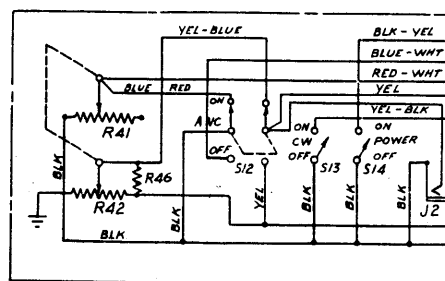
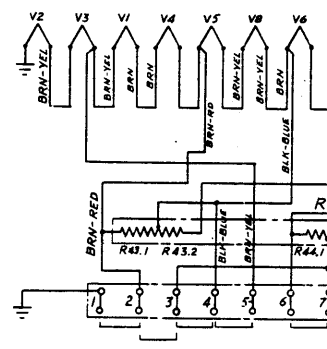
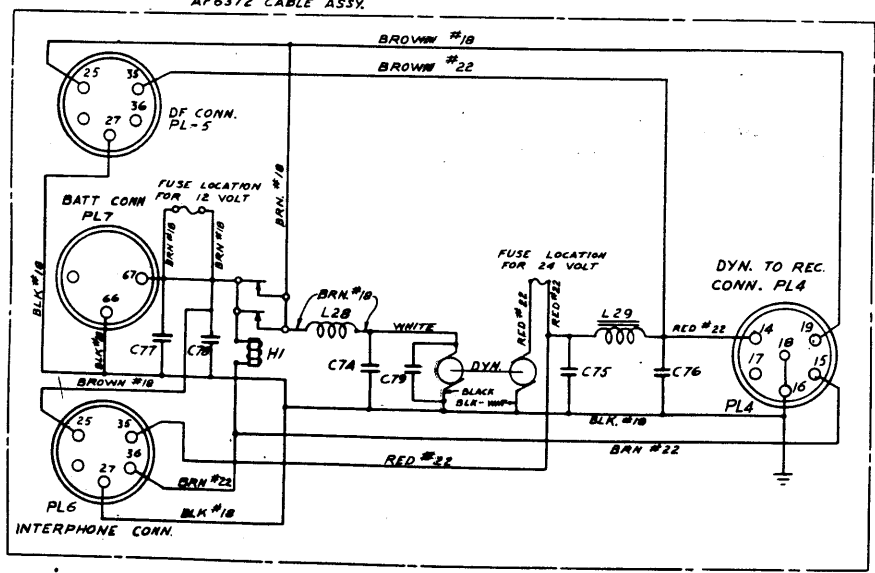
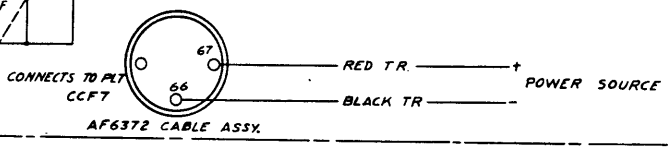
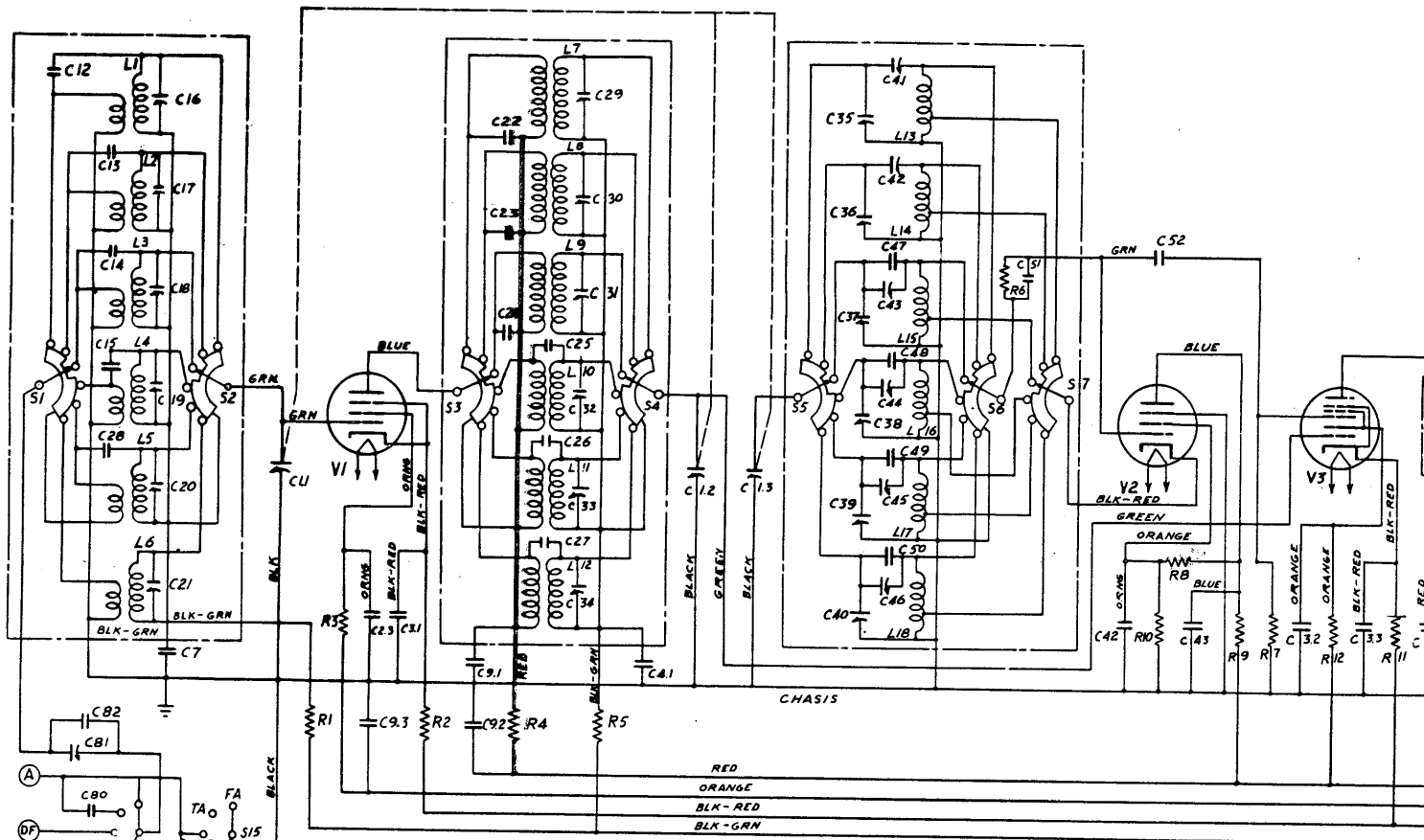

FIG.14-TYPE MP-5B OR MP-5A24 OUTLINE DRAWING



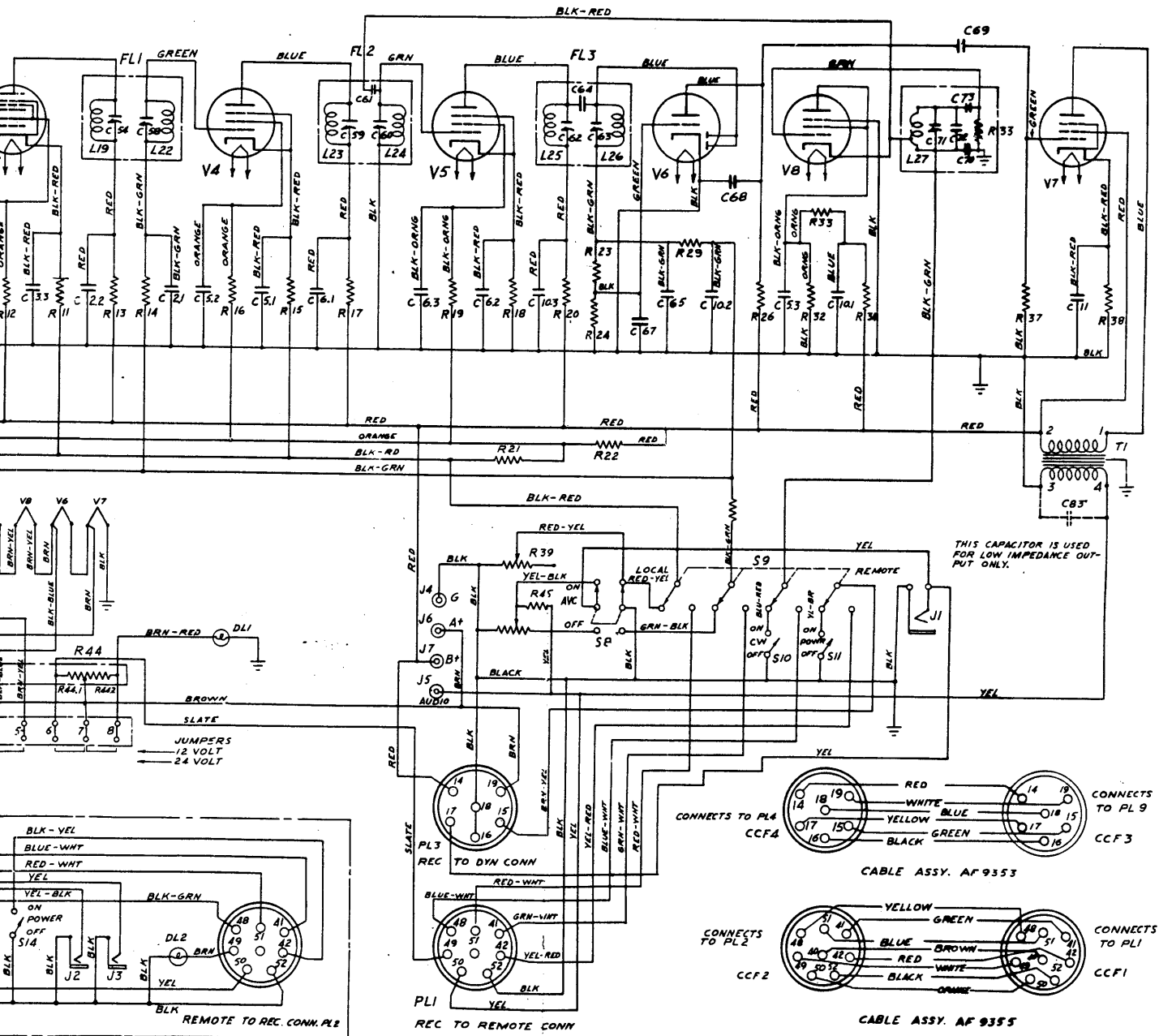
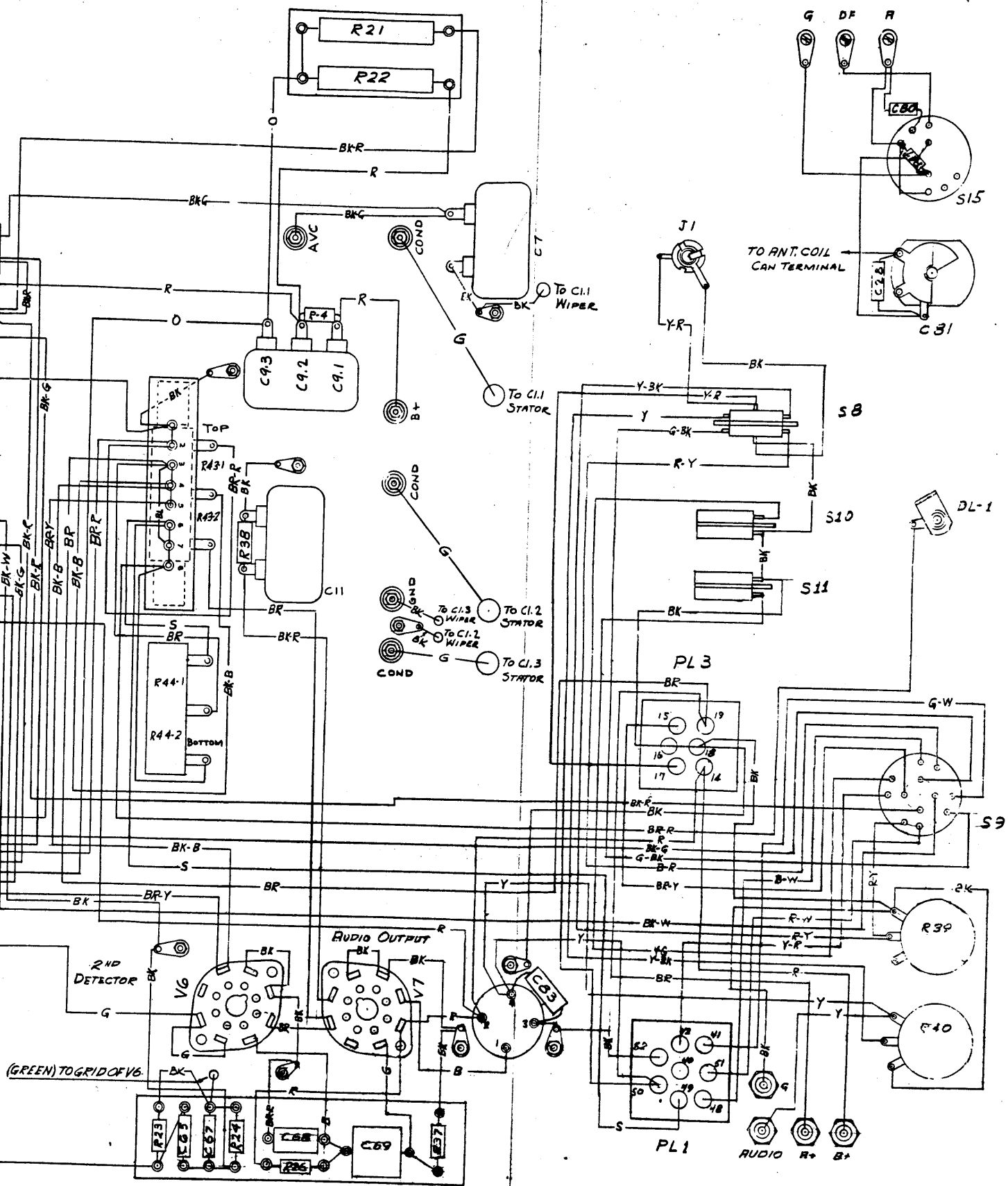
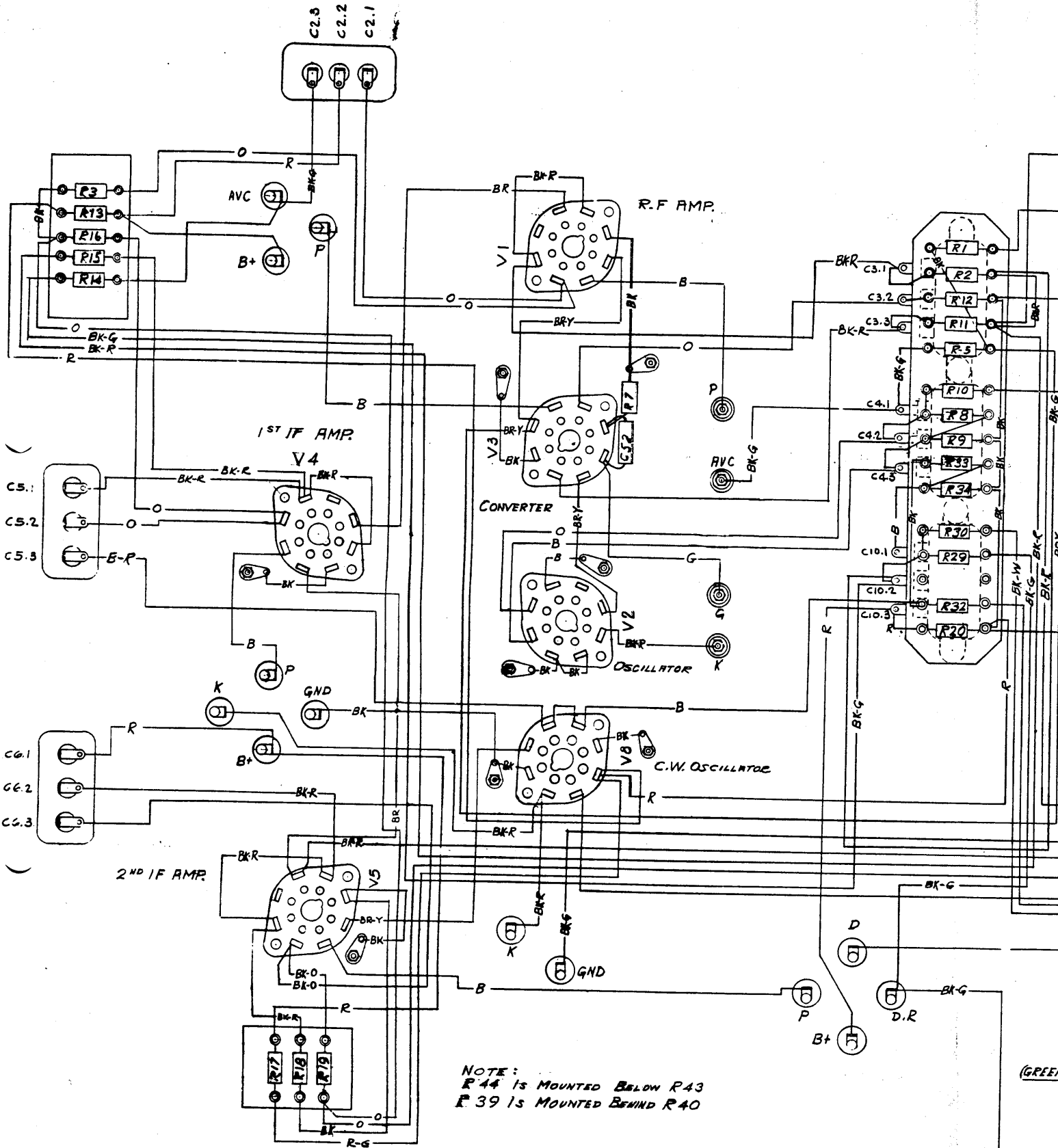

FIG.15-TYPE RA-1B RECEIVER UNIT SCHEMATIC DIAGRAM



TYPE RA-1B RECEIVER WIRING DIAGRAM



NOTE:
 R 44 IS MOUNTED BELOW R 43
 R 39 IS MOUNTED BEHIND R 40

NOTE:
 FOR 12 VOLT OPERATION CONNECT
 TERMINALS 1&2, 3&4&5, 6&7&8
 FOR 24 VOLT OPERATION CONNECT
 TERMINALS 2&3 ONLY.
 JUMPER SHOWN FOR 12 V. OPERATION

(GREEN)

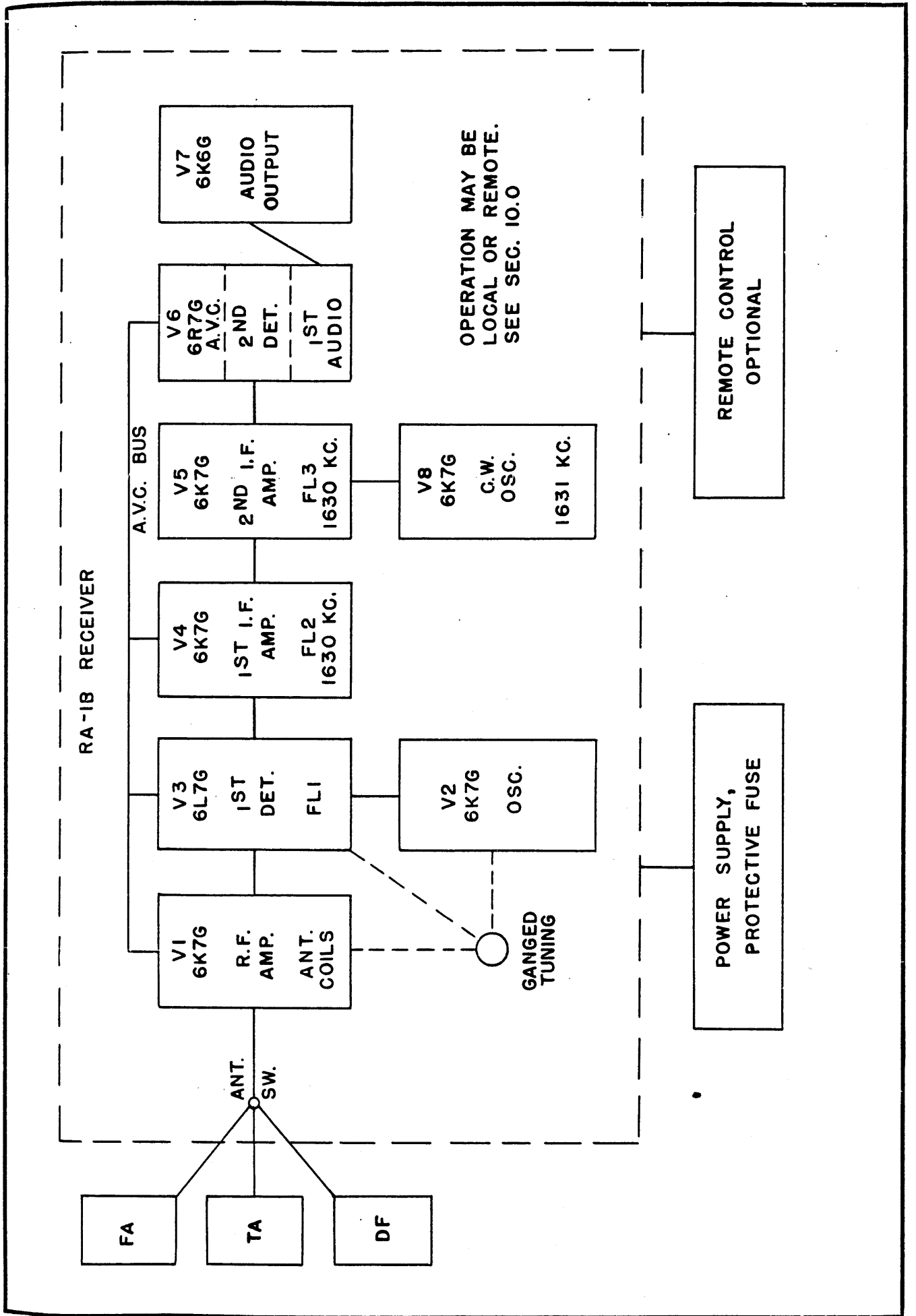

FIG. 16 BLOCK DIAGRAM OF RA-1B RECEIVER FUNCTIONS