

SERVICE MANUAL MANUEL D'ENTRETIEN WARTUNGSHANDBUCH



HITA-02938

C1421R/T PAL-I
CP1421R/T PAL-B/G
CL1421R/T P/SECAM-L
CP2021R/T PAL-B/G
C2121R/T PAL-I
CP2121R/T PAL-BG
CL2121R/T P/SECAM-L

CAUTION :

Before servicing this chassis, it is important that the service technician read the "Safety Precautions" and "Product Safety Notices" in this service manual.

ATTENTION :

Avant d'effectuer l'entretien du châssis, le technicien doit lire les "Précautions de sécurité" et les "Notices de sécurité du produit" présentés dans le présent manuel.

VORSICHT :

Vor Öffnen des Gehäuses hat der Service – Ingenieur die "Sicherheitshinweise" und "Hinweise zur Produktsicherheit" in diesem Wartungshandbuch zu lesen.

Data contained within this Service manual is subject to alteration for improvement.

Les données fournies dans le présent manuel d'entretien peuvent faire l'objet de modifications en vue de perfectionner le produit.

Die in diesem Wartungshandbuch enthaltenen Spezifikationen können sich zwecks Verbesserungen ändern.

TECHNICAL SPECIFICATIONS

TV Standard625 lines,
STANDARD I (UK)
B/G/H, L/L', (Export)

Channel coverageUHF Channels (UK)
UHF/VHF Hyper band (Export)

Aerial input impedance75 ohm
unbalanced

Programme Selectors ...Channel UP/DOWN
buttons with 70 programme
remote control
CH direct input

Power Consumption

142139W
202149W
212149W

Picture tubes

142137 cm type
202151 cm type
212155 cm type

Mains Voltage220V/240V 50 Hz

FuseF4AH 4.0A Type

FocusingElectro static

SPECIFICATIONS TECHNIQUES

Standard TV625 lignes,
STANDARD : R-U
B/G/H L/L': (Export)

Couverture de canaux ...Canaux UHF (R-U)
UHF/VHF Band hyper (Export)

Impédance d'entrée d'antenne75 ohm
non équilibré

Sélecteurs de programmesTouches de
sélection de canaux UP/DOWN (HAUT/BAS)
avec 70 programmes
Télécommande
Entrée directe canal (CH)

Consommation propre

142139W
202149W
212149W

Tubes-images

1421type 37 cm
2021type 51 cm
2121type 55 cm

Tension secteur220V/240V/50 Hz

FusibleType F4AH 4.0A

Mise au pointElectrostatique

TECHNISCHE DATEN

Fernsehnorm625 Zeilen,
Fernsehnorm I (nur GB)
Fernsehnorm B/G/H, L/L

KanäleUHF-Bereich (GB)
UHF-/VHF-/Hyperband-Bereich (Export)

Antenneneingangsimpedanz75 Ohm
unsymmetrisch

SenderwahlAUF/AB-Taste
auf Fernbedienung für 70 Sender
Senderdirekteingabe

Leistungsaufnahme

142139W
202149W
212149W

Bildröhre

142137 cm
202151 cm
212155 cm

Netzspannung220V-240V, 50Hz

SicherungF4AH4 0A

FokussierungElektrostatisch

HITACHI SERVICE MANUAL

MANUEL D'ENTRETIEN

WARTUNGSHANDBUCH

	INDEX	SOMMAIRE	INHALTSVERZETCHNIS
	English	Français	Deutsch
Safety instruction Précautions de sécurité Sicherheitshinweise	2-UK	2-F	2-D
TV operation supplement Supplément sur le fonctionnement du téléviseur Ergänzung zur TV-betriebsanleitung	3-UK	3-F	3-D
Identification of functions on remote control Description des commandes de la télécommande Übersicht über die bedienelemente auf der fernbedienung	4-UK	4-F	4-D
Tuning in the TV channels Programmation des canaux TV Einstellen der TV-Kanäle	5-UK	5-F	5-D
Connecting external equipment Connexion de périphériques Anschluss externer geräte	7-UK	7-F	7-D
Circuit description Description des circuits Schaltkreisbeschreibung	8-UK	8-F	8-D
Alignment instructions Instructions d'alignement Ausrichtungsinformationen	16-UK	16-F	16-D

Common information

Block diagram	19
Printed circuit board	20
Schematic diagram	21
Wave forms	22
Electrical parts list	23
Difference of parts for CRT	35
Difference of parts for system	36
Difference of parts for option	37
Mechanical exploded view and part list	38

SAFETY PRECAUTIONS

WARNING : The following precautions should be observed.

1. Do not install, remove, or handle the picture tube in any manner unless shatter proof goggles are worn. People not so equipped should be kept away while picture tubes are handled. Keep the picture tube away from the body while handling.
2. When service is required, an isolation transformer should be inserted between the power line and the receiver before any service is performed on the chassis.
3. When replacing the chassis in the cabinet, ensure all the protective devices are put back in place.
4. When service is required, observe the original lead dressing. Extra precautions should be taken to ensure correct lead dressing in the high voltage circuit area.
5. Always use the manufacturer's replacement component. Always replace original spacers and maintain lead lengths. Especially critical components are indicated as \triangle on the parts list and should not be replaced by other makes. Furthermore, where a short circuit has occurred, replace those components that indicate evidence of overheating.
6. Before returning a serviced receiver to the customer, the service technician must thoroughly test the unit to be certain that it is completely safe to operate without danger of electrical shock, and be sure that no protective device built into the instrument by the manufacturer has become defective, or inadvertently damaged during servicing.

Therefore, the following checks are recommended for the continued protection of the customers and service technicians.

INSULATION

Insulation resistance should not be less than 10M ohms at 500V DC between the main poles and any accessible metal parts.

Also, no flashover or breakdown should occur during the dielectric strength test, applying 3kV AC or 4.25kV DC for two seconds between the main poles and accessible metal parts.

HIGH VOLTAGE

High voltage should always be kept at the rated value of the chassis and no higher, Operating at higher voltages may cause a failure of the picture tube or high voltage supply, and also, under certain circumstances could produce X-radiation levels moderately in excess of design levels. The high voltage must not, under any circum-

stances, exceed 29kV on the chassis.

X-RADIATION

TUBES : The primary source of X-radiation in this receiver is the picture tube. The tube utilised for the above mentioned function in this chassis is specially constructed to limit X-radiation.

For continued X-radiation protection, replace tube with the same type as the original HITACHI approved type.

PRODUCT SAFETY NOTICE

Many electrical and mechanical parts in HITACHI television receivers have special safety related characteristics. These characteristics are often not evident from visual inspection nor can the protection afforded by them necessarily be obtained by using replacement components rated for higher voltage, wattage, etc. Replacement parts which have these special safety characteristics are identified by marking with a \triangle on the schematics and the replacement parts list contained in this service manual.

The use of a substitute replacement component which does not have the same safety characteristics as the HITACHI recommended replacement one, shown in the parts list of this service manual, may create electrical shock, fire, X-radiation, or other hazards.

Product Safety is continuously under review, and new instructions are issued from time to time. For the latest information, always consult the current HITACHI service manual. A subscription to, or additional copies of HITACHI service manuals may be obtained at a nominal charge from your HITACHI SALES CORPORATION.

CE MARK

Some of these models may contain the CE mark on the rating plate.

This illustrates that the T.V contains parts that have been specifically approved to provide electromagnetic compatibility to designated levels.

Therefore, when replacing any part in this T.V., please use only the correct part itemized in the parts list of this service manual to ensure this standard is maintained.

Also, take care to replace lead dressing to its original state, as this can also have a bearing on the electromagnetic radiation/immunity.

TUBE DISCHARGE

The line output stage can develop voltages in excess of 25kV; if the E.H.T. cap is required to be removed, discharge the anode to chassis via a high value resistor, prior to its removal from the tube.

TV OPERATION SUPPLEMENT

**The following pages
are extracted from the
Customer Operating Guide
to assist Service Engineers
in TV set up**

IDENTIFICATION OF FUNCTIONS ON REMOTE CONTROL

The Remote Control is designed for both TVs with and without teletext. Consequently, some of keys have multiple functions as follows :

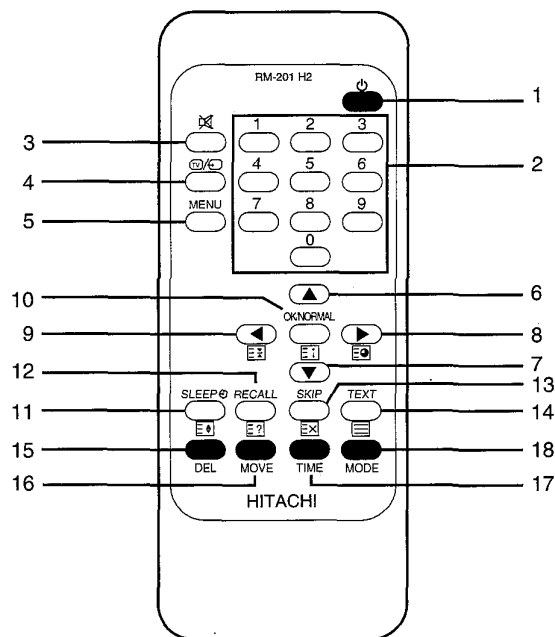

TV mode (without teletext)

- 1. TV ON/OFF (Stand-by mode)
- 2. **0-9** Channel selector
- 3. Mute (Switches off the sound)
- 4. TV/Audio-video selector
- 5. **MENU** Display ON/OFF
- 6. Program up
- 7. Program down
- 8. Volume up
- 9. Volume down
- 10. **OK**
- 10. **NORMAL** Picture selection
- 11. **SLEEP** TV auto-off-time selection
- 12. **RECALL** Information watching channel
- 13. **SKIP** (EDIT Menu)
- 15. **DEL** (EDIT Menu)
- 16. **MOVE** (EDIT Menu)

Menu mode

- 6. Cursor up
- 7. Cursor down
- 8. Cursor right
- 9. Cursor left
- 10. Menu selection
- 13. Skipping channel
- 15. Deleting channel
- 16. Moving channel order

TELETEXT mode

- 14. TEXT ON/OFF (return to TV mode)
- 1. TV ON/OFF (Stand-by mode)
- 2. **0-9** Teletext page selector
- 3. Mute
- 4. Not used
- 5. **MENU** For volume & brightness control
- 6. Teletext page up
- 7. Teletext page down
- 8. Teletext subpage
- 9. Teletext holding
- 10. Index page
- 11. Doubling teletext character size
- 12. Revealing hidden answer
- 13. Temporary cancelation of teletext
- 17. **TIME** TIME display on screen
- 18. **MODE** Not used

Colour buttons have dual functions :

Easy page access
in FASTEXT

- 15. Red
- 16. Green
- 17. Yellow
- 18. Blue

Menu mode 5

- 15. Volume down
- 16. Volume up
- 17. Bright down
- 18. Bright up

NB : Teletext mode operations are only applicable to TVs with teletext.
Models : C1421T/C2121T.

TUNING IN THE TV CHANNELS

AUTOMATIC TUNING SYSTEM

■ MAIN MENU

Press the **MENU** button to call up the **MAIN MENU** on the TV screen, The **MAIN MENU** consists of 5 sub-menus: **PICTURE, TIMER, LANGUAGE, PRESET** and **EDIT**.



■ LANGUAGE SELECTION

Select the **LANGUAGE** you require on the **MAIN MENU** by placing the cursor on **LANGUAGE** with the **UP/DOWN** buttons and pressing the **OK** button. You can choose the language you require with the **UP/DOWN** buttons.



Press the **MENU** button to return to the **MAIN MENU**.

Press the **MENU** button again to exit the **MAIN MENU**.

■ AUTOMATIC TUNING SYSTEM

Select the **PRESET** menu on the **MAIN MENU** and press the **OK** button.



Place the cursor to "  " with the **RIGHT** button and then press the **OK** button

If your TV is equipped for teletext (C1421T/C2121T), The country menu will be displayed for your selection by use of the **UP/DOWN** buttons.

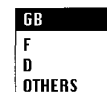

Press and hold down the **OK** button until the **AUTO-SEARCH** tuning screen appears above the **PRESET** menu. The cursor will move automatically from left to right, searching for all available TV stations in your area. Please wait approximately 3 minutes until the **EDIT** menu appears on the screen.



EDIT

The **EDIT** menu shows you the programme position assignment. When using this **AUTO-SEARCH** method, the broadcasts may not be found and stored in the order you desired. For example, BBC1 may not be allocated to programme number 01, and BBC2 may not be allocated to programme number 02, etc. The **EDIT** menu enables you to change the programme position assignment according to your personal preference.

■ SKIPPING THE CHANNELS

You can select **SKIP "YES"** or **"NO"** with the **SKIP** button. A programme marked with **SKIP "YES"** is skipped when changing channel using the **UP/DOWN** button. A skipped programme number selected by **NUMBER** button 0..9 will be displayed in red.

EDIT					
P	SKIP	P	SKIP		
00	----	NO	05	----	NO
01	----	NO	06	----	YES
02	----	NO	07	----	NO
03	----	NO	08	----	NO
04	----	NO	09	----	NO

■ DELETE PROGRAMME POSITION DATA

Position the cursor to the programme number to be deleted with the **UP/DOWN, LEFT/RIGHT** buttons. Press the **DEL** button. While this is being carried out the **"DELETE Prog. No"** appears and the **"deleted"** programme is moved to the programme No. 69 with **SKIP** changed to **"YES"**. The programme located in programme No. 69 will move to programme No. 68.

EDIT					
P	SKIP	P	SKIP		
00	----	NO	05	----	NO
01	----	NO	06	----	NO
02	----	NO	07	----	NO
03	----	NO	08	----	NO
04	----	NO	09	----	NO

DELETE 01

TUNING IN THE TV CHANNELS

■ CHANGING THE ORDER OF THE CHANNELS

Position the cursor to the programme number you want to move and press the MOVE button. The "MOVE Prog. No." will appear. Position the cursor to the programme number to be exchanged and press MOVE button.

Two programmes will be exchanged.

■ ENTERING A STATION NAME, CHANGING THE PROGRAMME NUMBER AND COPYING A PROGRAMME

You can go to the PRESET menu directly to enter a station name, change a programme number and copying one programme to another programme No. by pressing the OK button. Refer to the MANUAL CHANNEL SETTING.

EDIT					
P		SKIP	P		SKIP
00	ARD	NO	05	RTL2	NO
01	ZDF	NO	06	----	NO
02	BR3	NO	07	----	NO
03	SAT1	NO	08	----	NO
04	PR07	NO	09	----	NO

MOVE 02

MANUAL CHANNEL SETTING

Select the PRESET menu on the MAIN MENU.

Press the NUMBERED buttons 0..9 or UP/DOWN buttons to select a programme number you want. The screen will change according to the selected programme number.

■ SEARCHING A CHANNEL

Locate a cursor to " " with LEFT/RIGHT button and then press the UP or DOWN button. The SEARCH tuning screen will appear and the cursor will move from left to right or vice versa.

After searching a station, the tuning screen will disappear. To stop searching, press the MENU button.

■ FINE TUNING

If you are unable to get a good picture or sound by performing SEARCH function, it is possible to adjust the fine tuning.

Move the cursor to " " and press UP or DOWN button to activate fine tuning UP or DOWN. It only operates whilst the UP or DOWN button is being pressed.

■ ENTERING A STATION NAME

To select a station from the station name list. Move the cursor to " - - - - " on the PRESET menu, then select a station name from the list using the UP/DOWN buttons and press the OK button. If you want to delete a station name, select "...". If you cannot find the desired name in the list, you can enter your own. To do so, move the cursor to the right and press OK button.

Using the UP/DOWN button, select the desired letter, number or blank.

Press the RIGHT button to select the next position.

Press the OK button complete this procedure.

■ TO STORE A PROGRAMME IN MEMORY

Move the cursor to the extreme right of the display with the LEFT/RIGHT buttons. Select the programme number that you want store the currently displayed programme, with station name and fine tuning data in memory using the UP/DOWN or 0..9 buttons. Press the OK button. The colour of "P- -" will change into green for a second and then back into red.

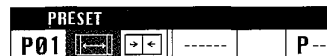

CONNECTING EXTERNAL EQUIPMENT

■ HEAD PHONE SOCKET

When you insert a headphone plug (3.5mm stereo) into the headphone socket, the sound from the speaker will automatically be muted.

■ FRONT AV SOCKET

Connect the **AV (AUDIO/VIDEO)** socket with an appropriate cable to the corresponding socket of the external equipment.

Select AV mode by pressing the AV button ().

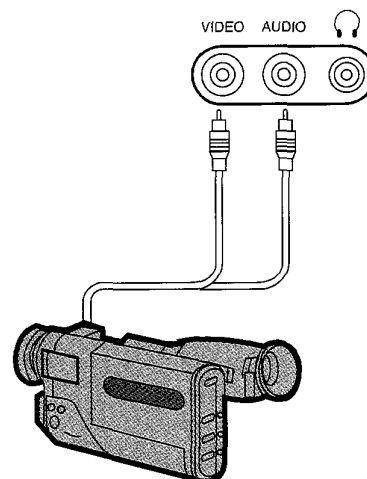

Press the AV button twice to return to the TV mode.



■ SCART SOCKET

This is used to connect : a VCR, a PAY-TV decoder, a Camcorder and a video game console.

In most cases, the set changes automatically to AV mode, when the VCR connected is in play back mode.

If not, press the **AV** button () on the remote control or on the front of the set. The **AV** symbol () will be displayed on the screen with the current TV programme number. In AV mode, you can change the TV programme number with the **UP/DOWN** button or the **NUMBERED** buttons 0..9.

If external equipment has an S-VHS signal output, you can also receive the S-VHS signal with an appropriate cable (e.g. with an S-VHS plug to Scart plug) by selecting S-VHS mode with the **AV** button ().

NB. It is not possible to control any of the functions except the volume control and mute function in the RGB mode. External equipment must be switched off to return to the TV mode.

NB. If equipment is connected to the front **AV SOCKET** and the **SCART SOCKET**, only one piece of equipment can be used.

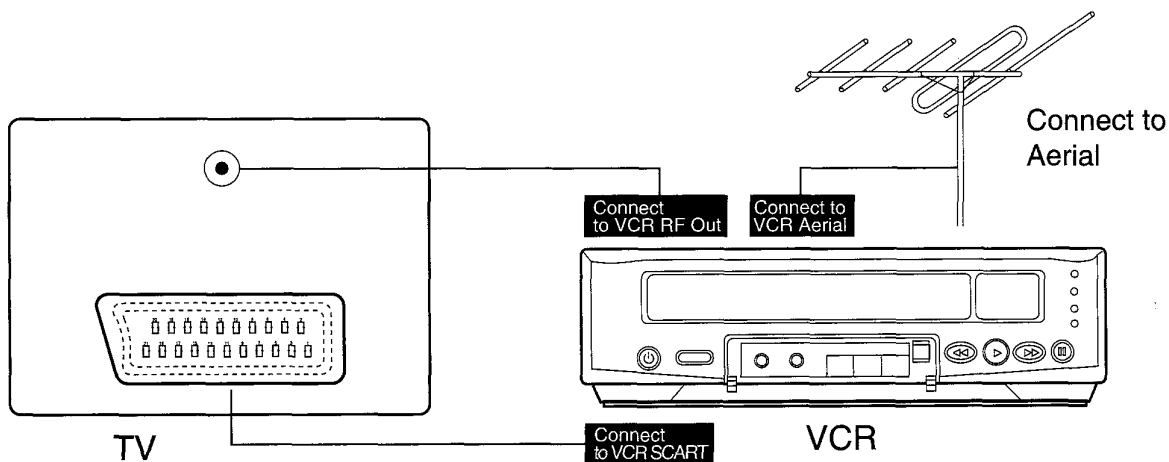

■ Circuit Description

Vision IF amplifier, AFC, video demodulator

The IF signal from the tuner is fed through a SAW filter to the differential IF input (pin 48 and 49). The first IF stage consists of 3 AC-coupled amplifiers with a total gain control range of over 66 dB. The reference carrier for the video demodulator is obtained by a PLL carrier regenerator (eliminating notch filter compromises, as in reference tuned circuits for passive carrier regeneration). Only an oscillator coil is needed (pin 3 and 4) that can be aligned via I2C-bus to the double IF frequency.

The AFC information is derived from the VCO control voltage of the IF-PLL and can be read via I2C-bus.

Bit AFB toggles when the picture carrier is exactly at the desired IF frequency (= half the aligned IF-PLL frequency).

AFA is active in a window around this point.

For fast search-tuning applications this window can be increased by a factor 3 (AFW bit).

Tuner A.G.C.

The automatic gain control (A.G.C.) circuit operates on top sync level at negative modulated signals or on peak white level at positive modulation, selected by MOD bit.

The tuner A.G.C. is controlled via pin 54.

The tuner A.G.C. take over point (T.O.P.) can be set over a wide range: 0.8 mVrms .. 80 mVrms IF input signal amplitude.

The tuner AGC output may have to operate above Vcc of TDA8374.

Therefore pin 54 is an open collector output, that can operate from 0.3 up to Vcc+ 1 Volt (at > 2 mA sink current)

PLL sound demodulator

The IF-video output at pin 6 (2Vpp) is fed through a sound bandpass filter and connected to the intercarrier sound IF input pin 1.

An alignment free PLL tunes itself to the sound carrier and demodulates it.

The non volume-controlled front-end audio signal can be obtained from the deemphasis pin 55 (amplitude 300 mVeff).

Source select switch

TDA8374 input switch can select one of the following sources ;

- pin 13 front-end : CVBS I int
- pin 17 : CVBS 2 ext
- pin 11, pin 10 : Y s-vhs, C s-vhs

Selected signal is available at the CVBS output pin 38, in case of Y/C input Y+C are added.

It drives teletext and the TDA8395 SECAM add-on.

For S-VHS applications, the Y,C input can be selected, independent of the CVBS source switch.

TDA8374 Y,C inputs are selected, while the source switch outputs CVBS I int or CVBS 2 ext on CVBS out.

Horizontal synchronization and protection

The synchronization separator adapts its slicing level in the middle between top-sync and black level of the CVBS signal.

The separated synchronization pulses are fed to the first phase detector and to the coincidence detector.

The ϕ -1 loop gain is determined by the components at pin 43 (C+RC).

The coincidence detector detects whether the horizontal line oscillator is synchronized to the incoming video.

The line oscillator is a VCO-type, running at twice the line frequency.

It is calibrated with the X-tal oscillator frequency of the colour decoder and has a maximum deviation of 2% of the nominal frequency, so no alignment is needed.

Calibration is done at start up (the TDA8374 must first know what colour X-tals are connected, bits XA and XB) and after synchronization loss (ϕ -1 coincidence detector "Sync Locked" bit SL).

The second phase detector ϕ -2 locks the phase of the horizontal driver pulses at output pin 40 to the horizontal flyback pulse at input pin 41 .

This compensates for the storage time of the horizontal deflection transistor.
 The ϕ - 2 loop filter (C) is externally connected to pin 42.
 The horizontal phase can be given a static off set via I2C-bus (HSH "horizontal shift")
 A dynamic correction is possible by current feedback into the ϕ - 2 loop filter capacitor.

To protect the horizontal deflection transistor, the horizontal drive is switched off immediately when a power failure (" Power-On Reset " bit POR) is detected.
 The power failure may have corrupted the contents of the internal data registers, so the TDA8374 should be started up again.

The TDA8374 has a separate supply input (pin 37) that is only used as a clean supply voltage for the horizontal oscillator circuits.

Vertical synchronization

The vertical sawtooth generator drives the vertical output.
 It uses an external capacitor at pin 51 and a current reference resistor at pin 52.
 The TDA8374 vertical drive has differential current outputs for DC-coupled vertical output stage, like the TDA8356 .
 At TDA8356 input pins 1 and 2 this current is converted into a drive voltage via a resistor

Geometry processing

With the TDA8374 it is possible to implement automatic geometry alignment, because all parameters are adjusted via the I2C bus.

The deflection processor of the TDA8374 offers the following five controls;

- Horizontal shift
- Vertical slope.
- Vertical amplitude
- Vertical S-correction
- vertical shift

Colour decoder

The colour decoder contains an alignment-free X-tal oscillator, a dual killer circuit and colour difference demodulators.
 Together with the TDA8395 SECAM add-on a multi standard PAL/SECAM/NTSC decoder can be built with automatic recognition.

Which standard can be decoded depends on the external Xtals used.

Two Xtal pins (34 and 36) are present so normally no external switching is required.

The I.C. must be told which X-tals are connected (bits XA and XB).

This is important, because the X-tal frequency of the colour decoder is also used to calibrate many internal circuits.

The burst phase detector locks the Xtal oscillator with the chroma burst signal.

The phase detector operates during the burst key period only, to prevent disturbance of the PLL by the chroma signal.

Two gain modes provide:

- Good catching range when the PLL is not Locked.
- Low ripple voltage and good noise immunity once the PLL has locked

The killer circuit switches-off the R-Y and B-Y demodulators at very low input signal conditions (chroma burst amplitude).

A hysteresis prevents on/off switching at low, noisy signals.

Color standard	pin34	pin35	XA	XB
PAL4.43/SECAM + NTSC-4.43	none	4.43	1	0
PAL4.43/SECAM + NTSC-M	3.58	4.43	1	1

Integrated video filters

The TDA8374 has alignment-free internal luminance delay, chroma bandpass and chroma trap.

They are implemented as gyrator circuits tuned by tracking to the frequency of the chroma Xtal oscillator.

The chroma trap in the Y signal path is by-passed when Y/C input is selected (S-VHS).

For SECAM an extra luminance delay is built-in, for correct delay of the luminance signal.

RGB output and black current stabilization

The colour difference signals (R-Y, B-Y) are matrixed with the luminance signal (Y) to obtain the RGBout output signals (pins 21,20,29).

In the TDA8374 the matrix type automatically adapts to the decoded standard (NTSC,PAL).

Linear amplifiers are used to interface external RGB in signals (pins 24,25,26) from the SCART connector.

These signals overrule the internal RGB signals when the data insertion pin 26 (FBI) is switched to a level between 1.0V and 3.0V.

The contrast and brightness control and the peak white limiter operate on both internal and external RGB signals R,G and B each have their own, independent gain control to compensate for the difference in phosphor efficiencies of the picture tube: so called "white point" adjustment.

The nominal amplitude is about 2V black to white, at nominal input signals and control settings.

TDA8374 has a black current stabilization loop, that automatically adjust the black level to the cut-off voltage of the picture tubes three gun cathodes.

Since no current is flowing when the voltage of the cathode is equal to the cut-off voltage of the tube, the loop stabilizes at a very small gun current.

This "black current" of the three guns is measured internally and compared with a reference current, to adjust the black level of RGBout.

The black level loop is active during 4 lines at the end of the vertical blanking.

In the first line the leakage current is measured (max. acceptable 100 μA).

In the next three lines the black levels of the three guns are adjusted.

The nominal value of the 'black current' is 10 μA .

The ratio of the 'black currents' for the 3 guns tracks automatically with the white point adjustment, so the back-ground colour is the same as the adjusted white point.

At switch-on of the TV receiver the black current stabilization circuit is not yet active and RGBout are blanked.

Before the first measurement pulses appear, 0.5 sec delay ensures that the vertical deflection is active, so the pulses will not be visible on the screen.

During the measuring lines RGBout will supply 4V pulses to the video output stages.

The TDA8374 waits until the black current feedback input (pin 18) exceeds 200 μA , which indicates that the picture tube has warmed up.

Then the black current stabilization circuit is active.

After a waiting time of about 1.0 sec, the blanking of RGBout is released.

Tuning

The AFC information of the TDA8374 is not available as an analogue voltage.

Automatic following (=frequency tracking, AFC) can be done via the I2C-bus by software.

The TDA8374 AFC window is typically 80 kHz wide.

This value is made higher than the 62.5 kHz tuning step, to prevent an automatic following loop from continuously adapting the tuning frequency..

With this AFC window (± 40 kHz) the maximum tuning error is less than 62.5 kHz.

For high speed search-tuning-algorithms, the AFC window can be widened to 240 kHz via bit AFW.

TDA8395 SECAM decoder

The TDA8395 is an alignment-free SECAM colour decoder, including a Cloche filter, demodulator and line identification circuit.

The Cloche filter is a gyrator-capacitor type.

Its frequency is calibrated in the vertical retrace period.

The calibration reference(pin 1) is obtained from the TDA8374 colour X-tal oscillator (pin 33).

Pin 7 is a decoupling for the Cloche reference.

The voltage change at this pin due to leakage currents should be lower than 10 mV, during field scan, resulting in a capacitor of minimal 100 nF.

Pin 8 is the reference capacitor for the PLL.

The voltage variation during field scan at this pin should be lower than 2 mV , resulting in a capacitor of 220 nF.

The sandcastle input (pin 15) is connected to TDA8374 pin 41 and is used for generation of the blanking periods and provides clock information for the identification circuit.

The CVBS source select output (TDA8374 pin 38) supplies SECAM chroma to pin 16 of the TDA8395.

This is demodulated by a PLL demodulator, that uses the reference frequency at pin 1 and a bandgap reference to obtain the desired demodulation characteristic.

If the digital line identification in the TDA8395 detects SECAM, pin 1 will sink a current of 150 μ A out of TDA8374 SECAMref pin 33.

When the TDA8374 has not detected PAL or NTSC, it will respond by increasing the voltage at pin 33 from 1.5V to 5V.

Now the TDA8374 colour difference outputs pin 30 and 29 are made high-ohmic and the TDA8395 output pin 9 and 10 are switched on.

These outputs will be disconnected and high-ohmic when no SECAM is detected for two frame periods, the decoder will be initialized before trying again.

SECAM-L and -L' application

For SECAM-L and L' the TDA8374 has to be switched to positive modulation via I2C-bus bit MOD.

SECAM-L' signals only occur in VHF band I and have their picture and sound carrier interchanged, compared to SECAM-L/PAL channels.

For SECAM-L' the IF picture carrier is situated at 34.2 MHz and the AM-sound carrier at 40.7MHz.

Therefore the IF-PLL reference has to be tuned away from 38.9 to 34.2 MHz.

This can be done via I2C-bus sub-address 15hex (IF-PLL).

The AM sound output is inserted at TDA8374 external audio input pin via the SCART plug.

When bit MOD selects positive modulation for SECAM-L/L', the TDA8374 automatically switches to external audio.

Base band delay line TDA4665

TDA4665 is an integrated double baseband delay line of 64 μ S

It couples to the TDA8374 and TDA8395 without any switches or alignments.

The TDA4665 consist of two main blocks:

- Two delay lines of 64 sec in switched capacitor technique
- Internal clock generation of 3 MHz, line locked to the sandcastle pulse

The TDA4665 operates according to the mode demanded by the colour transmission standard:

- For PAL it operates as geometric adder to satisfy the PAL demodulation requirements
- In NTSC mode it reduces cross-colour interference (comb-filtering)
- For SECAM it repeats the colour difference signal on consecutive horizontal scan lines.

A sandcastle pulse is connected to pin 5.

The top pulse voltage (should not exceed 5 V) can be directly coupled to the 5 V sandcastle output of the TDA8374.

The R-Y and B-Y colour difference signals (from TDA8374 pins 30 and 29) are AC-coupled and clamped by the input stages at pins 16 and 14.

An internal 6 MHz Current controlled oscillator is line locked via a PLL to the sandcastle pulse at pin 5.

This clock drives the delay lines to obtain the required 64 μsec .

Sample and hold low pass filters suppress the clock signal.

The original and the delayed signals are added, buffered and fed to the output pins 11 and 12.

These are AC-coupled to the R-Y and B-Y colour difference input pin 32 and 31 of TDA8374.

The TDA4665 needs a 5 V supply voltage on pin 1 for the digital part and on pin 9 for the analog part.

TDA8356 vertical deflection.

The TDA8356 is a vertical deflection circuit.

It can be used in 90 degree deflection systems with frame frequencies from 50 up to 120 Hz

With its bridge configuration the deflection output can be DC coupled with few external components.

Only a supply voltage for the scan and a second supply for the flyback are needed.

The TDA8356 can drive max.2A.

The vertical drive currents of TDA8374 pins 47 and 46 are connected to input pins 1 and 2 of the TDA8356.

The currents are converted into a voltage by a resistor between pins 1 and 2.

Pin2 is on a fixed DC level (internal bias voltage) and on pin 1 the drive voltage can be measured (typical 1.8 Vpp).

The drive voltage is amplified by 'A' and fed to two amplifiers 'B' and 'C', one is inverting and the other is a non inverting amplifier.

The outputs (pins 4 and 7) are connected to the series connection of the vertical deflection coil and feedback resistor .

The voltage across feed back resistor is fed via pin 9 to correction amplifier 'D', to obtain a deflection current which is proportional to the drive voltage.

The supply voltage for the TDA8356 is 16V at pin 3.

The flyback generator has a separate supply voltage of 45V on pin 6.

The guard pulse is useful to synchronize OSD.

Horizontal deflection

The circuit contains horizontal drive, line output transformer.

The horizontal driver pulses from the TDA8374 are amplified in the horizontal drive circuit, to get sufficient base-drive current for the high voltage switching transistor Q401.

During the horizontal scan period(=52 μs) Q401 will conduct, and a sawtooth current flows from +110/123V through the primary winding of the FBT to ground.

After this time Q401 is switched off and the energy stored in the FBT during the scan period will be transformed to the flyback capacitor C410.

This energy transfer will take place in a cosine shape because the primary of the FBT and C410 form a resonant circuit. The time the energy is transferred from FBT to C410 and back to the FBT, is called the flyback time and will take place in about 12 μs .

The flyback peak voltage is about 8 times the scan voltage.

In series with the horizontal deflection coil there is a (damped) linearity corrector coil.

During the scan there is some loss in the resistance of the deflection coil.

In the first part of a line the linearity corrector stores some energy in a permanent magnet until it is saturated.

This improves the linearity of the horizontal scan speed.

The required S correction for the picture tube can be adjusted with the value of C411.

The beam current limiting information (BeamCurr) is derived from the foot of the H.V winding of the FBT.

This is connected via a resistor to +8V.

As the beam current increases, the voltage on line BeamCurr decreases.

BeamCurr is damped by a integration filter before it is fed back to TDA8374 pin 22.

The TDA8374 will decrease the contrast (and eventually the brightness) to limit the average beam current.

Video amplifiers

Three TDA6106Q integrated video amplifiers drive cathodes of the picture tube directly.

They are protected against CRT flashover discharges and ESD (electro static discharge).

The three video amplifiers, have a beam current output in black, used by the TDA8374 black current loop to control the black level on the cathodes.

The outputs can be connected together because the black current loop sequentially controls the black level for each cathode.

The amplification of the TDA6106Q is set by the resistors between pin 3 and 9 and between pin 3 (negative-input) and the TDA8374 output.

There is no alignment any more on the CPT panel, because of the automatic black current stabilization and because the white point adjustment can be done in the TDA8374 via I2C bus.

Power Supply STR-S5707

(1) VIN terminal, start-up circuit

The start-up circuit is to start and stop the operation of the control IC by detecting the voltage appearing at the VIN terminal (pin-9).

At start up of the power supply, when a voltage at the VIN terminal reaches to 8V (typical) by charging up C807 by the function of the start-up resistor, R803, the control circuit starts operating by the function of the start-up circuit.

After the control circuit starts its operation, power source is obtained by smoothing voltage appearing at winding of pin6-7 of T801.

(2) Oscillator, F/B terminal voltage (Pin 7)

An oscillator generates pulse signals which turns the power transistor on and off by making use of charge and discharge of C1 and C2 incorporated in the Hybrid IC.

Constant voltage control of the switched-mode power supply is performed by changing both ON-time and OFF-time except when the load is light (e.g. remote control stand-by mode of TVs).

The ON-time is controlled by changing a current charged by C1, which is as the result of that the detection winding of pin5-7 of T801, which detects a change of voltage on the secondary side, connected to the sensing terminal (Pin 7) has the current in accordance with an output signal from an output voltage detection circuit (an error amplifier) built in.

As the AC input voltage to the power supply becomes higher and the load current reduces, the current flowing to the SENS terminal becomes larger, and the ON-time becomes shorter.

(3) Function of INH terminal (Pin 6), control of OFF-time

Signal to the INH terminal is used as inputs to COMP.1 and COMP.2 inside of the control IC.

A threshold voltage of COMP.1, VTH1 is set at 0.75V ($T_a=25^\circ$) and an input signal to a drive circuit becomes almost 0V (the power transistor is in OFF mode) when a voltage at the INH terminal reaches the VTH1.

A threshold voltage of COMP.2, VTH2, is set at 1.5V ($T_a=25^\circ$).

When the INH terminal voltage reaches VTH2, an output from COMP.2 reverses (the power transistor is in on mode).

*Quasi-resonant operation

By inputting the voltage of winding of pin6-7 of T801 which is synchronized with the energy discharge time of a secondary winding, pin14(or 15)-16 of T801, to the INH terminal through D805 and R809, quasi-resonant operation can be achieved.

When the power transistor turns off and a voltage higher than VTH2 is applied to the INH terminal, C3 immediately discharges and then starts charging again.

Even after the discharge of energy of a secondary winding is completed, VINH does not immediately increase. When it gets lower than VTH1, the transistor turns on.

* Stand-By Mode

While being in remote control stand-by mode, the output voltage to the secondary side is kept on and the power transistor operates in class A mode.

By connecting INH terminal (Pin 6) to the GND, the OFF-time of the power transistor is fixed at set time (T_{OFF} = 50μsec at T_a = 25 °C) of the built-in oscillator, and only ON-time changes depending on input and output conditions of the power supply.

Therefore, it enables to hold an oscillation frequency in light mode below 20KHz (typical).

(4) Drive circuit

The STR-S5707 applies the proportional drive system in order to minimize turn-on and saturation loss, and storage time.

(5) OCP (over-current protection) function

Over-current protection is performed pulse by pulse by directly detecting collector current of the power transistor. Detecting voltage is set to -1V below a reference point of GND (ground).

(6) Latch circuit

It is a circuit which sustains an output from the oscillator low and stops operation of the power supply when over-voltage protection (OVP) circuit and thermal shutdown (TSD) circuit are in operation.

As the sustaining current of the latch circuit is 500 μA maximum when VIN terminal voltage is 4V, the power supply circuit sustains the off state as long as current of 500 μA minimum flows to VIN terminal from a start-up resistor.

In order to prevent a malfunction to be caused by a noise and so on, delay time is provided by C1 incorporated in the IC and, therefore, the latch circuit operates when the OVP or TSD circuit is in operation, or an external signal input is provided for about 10 μsec or longer.

In addition, even after the latch circuit starts operating, the constant voltage regulator (Reg) circuit is in operation and the circuit current is at high level.

As a result, VIN terminal voltage rapidly decreases.

When VIN terminal voltage becomes lower than the shutdown voltage, VIN(OFF) (4.9V typical), it starts increasing as the circuit current is below 500 μA.

When it reaches the ON-state voltage, VIN (ON) (8V typical), VIN terminal voltage starts decreasing because the circuit current increases again.

When the latch circuit is on, VIN terminal voltage increases and decreases within the range from 4.9V typical to 8V typical and is prevented from abnormally rising.

Cancellation of the latch is done by decreasing VIN terminal voltage below 3.3V.

The power supply can be restarted after disconnecting an AC input to the power supply once.

(7) Thermal shutdown circuit

It is a circuit to trigger the latch circuit when the frame temperature of the IC exceeds 150°C (typical).

Although the temperature is actually sensed at the control chip, it works against overheating of the power transistor as the power transistor and the control IC are mounted on the same lead frame

(8) Over-voltage protection circuit

It is a circuit to trigger the latch circuit when VIN terminal voltage exceeds 11V (typical).

Although it basically functions as protection of VIN terminal against over-voltage, since VIN terminal is usually supplied from the drive winding of the transformer and the voltage is proportional to the output voltage, it also functions against the over voltage of the secondary output which occurs when the control circuit becomes defective or in some other circumstances.

Alignment Instructions

1. AFT

1.1 Standard B/G,D/K,I and L

- 1) Set a Signal Generator with
 - RF FREQUENCY = 38.9 MHz,
 - RF OUTPUT LEVEL = 80 ± 5 dBuV
 - System = PAL / SECAM - B/G, D/K, I
- 2) Connect the Signal Generator RF Output to P101 (Tuner IF Output).
There must be no signal input to the tuner.
- 3) Press the "AFT" KEY and wait until the TV screen display "AFT OK".

1.2 Standard SECAM-L' (France VHF-Low)

- * Above mentioned "1.1" adjustment has to be done in advance.
- 1) Set a Signal Generator with
 - RF FREQUENCY = 34.2 MHz,
 - RF OUTPUT LEVEL = 80 ± 5 dBuV
 - System = SECAM - L'
 - 2) Connect the Signal Generator RF Output to P101 (Tuner IF Output).
There must be no signal input to the tuner.
 - 3) Press the "L' AFT" KEY and wait until the TV screen display "L AFT OK".

2. AGC

- 1) Set a Pattern Generator with RF LEVEL 63 ± 2 dBuV .
- 2) Connect a OSCILLOSCOPE PROBE to P101 (TUNER AGC INPUT).
- 3) Adjust AGC UP/DOWN KEY the voltage drop 1V dc over below its maximum voltage.

* Alternative Method

- 1) Set a Pattern Generator with
 - RF LEVEL 80 ± 5 dBuV
 - PAL CROSSHATCH
(without SOUND CARRIER)
- 2) Connect a OSCILLOSCOPE
(Bandwidth ≥ 100 MHz) PROBE
to P101 (TUNER IF OUTPUT).
- 3) Use AGC UP/DOWN KEY to obtain
an envelop amplitude $200 + 50$ mVp-p.

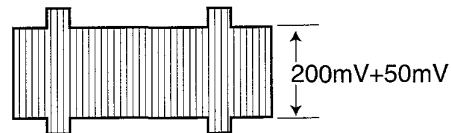

3. SCREEN

- 1) Apply a COLOUR BAR pattern signal.
- 2) Set the CONTRAST, BRIGHTNESS to MAX, COLOUR to MIN.
- 3) Set the R,G,B LEVEL to CENTER (31/63) with R,G,B UP/DOWN KEY.
- 4) Connect a OSCILLOSCOPE PROBE to P906 (CRT CATHODE R, G, B).
- 5) Adjust the SCREEN VOLUME on FBT such that the highest black level voltage 160 ± 5 Vdc (20", 21"), 130 ± 5 Vdc (14").

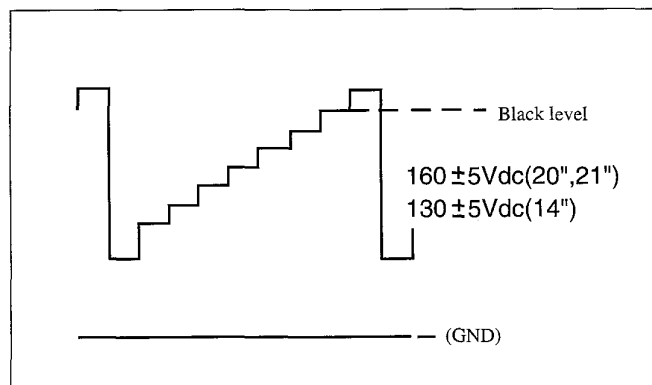

4. WHITE BALANCE

- 1) Set the TV to NOR I mode.
- 2) Set the R,G,B LEVEL to CENTER with R,G,B UP/DOWN KEY .
- 3) Adjust the R,G,B UP/DOWN KEY of the other colour which did not appear on the screen to obtain WHITE.

5. FOCUS

- 1) Apply a RETMA PATTERN signal.
- 2) Adjust the FOCUS VOLUME on FBT to obtain optimal resolution.

6. GEOMETRY

6.1 VERTICAL CENTER

- 1) Set the TV to NOR I mode.
- 2) Pressing the V-SIZE UP/DOWN KEY, the lower half of the screen is blanked.
- 3) Adjust the border line of blanked picture coincident with the mechanical center marks of the CRT using the V-SIZE UP/DOWN KEY.

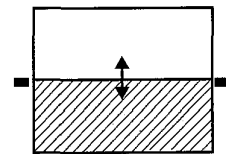

6.2 VERTICAL SIZE

- * The VERTICAL CENTER adjustment has to be done in advance.
- 1) Apply a RETMA PATTERN signal.
 - 2) Set the TV to NOR I mode.
 - 3) Adjust the upper part of the picture with the V-SIZE UP/DOWN keys.

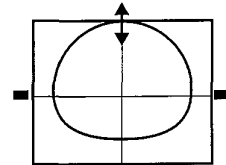

6.3 VERTICAL SLOPE

- * The VERTICAL SIZE adjustment has to be done in advance.
- 1) Apply a RETMA PATTERN signal.
 - 2) Adjust the lower part of the picture with the V-SLOPE UP/DOWN keys.

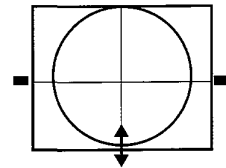

6.4 VERTICAL S-CORRECTION

- 1) Apply a CROSSHATCH PATTERN signal.
- 2) Adjust the S-COR UP/DOWN KEY to obtain the same distance between horizontal lines.

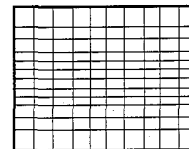

6.5 HORIZONTAL CENTER

- 1) Apply a RETMA PATTERN signal.
- 2) Adjust picture centering with CENTER LEFT/RIGHT keys.

If EEPROM (I703) has been changed ;

- Option data has to be changed and
- all alignment function has to be readjusted .

* Option

	Initial state (Blank EEPROM)	P/SECAM-L (FRANCE)	PAL-I (U.K)	PAL-B/G (CONTINENTAL)
AV	AV2	AV2	AV2	AV2
BAND	3 BAND	3 BAND	1 BAND	3 BAND
FRANCE	OFF	ON	OFF	OFF
ATS	ON	ON	ON	ON

* The initial state of adjustment are as follows;

- V-Center, V-Slope V-Size, H-Center, R, G, B, AFT = Center (30/64 - 33/64)
- S-Correction = 00/64
- AGC = 10/64

*Service Remocon (R-30SVC)

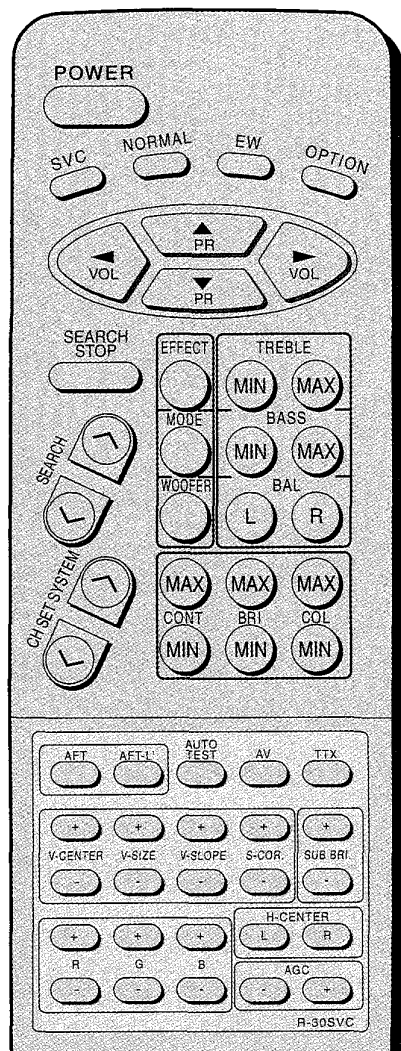

■ BLOCK DIAGRAM

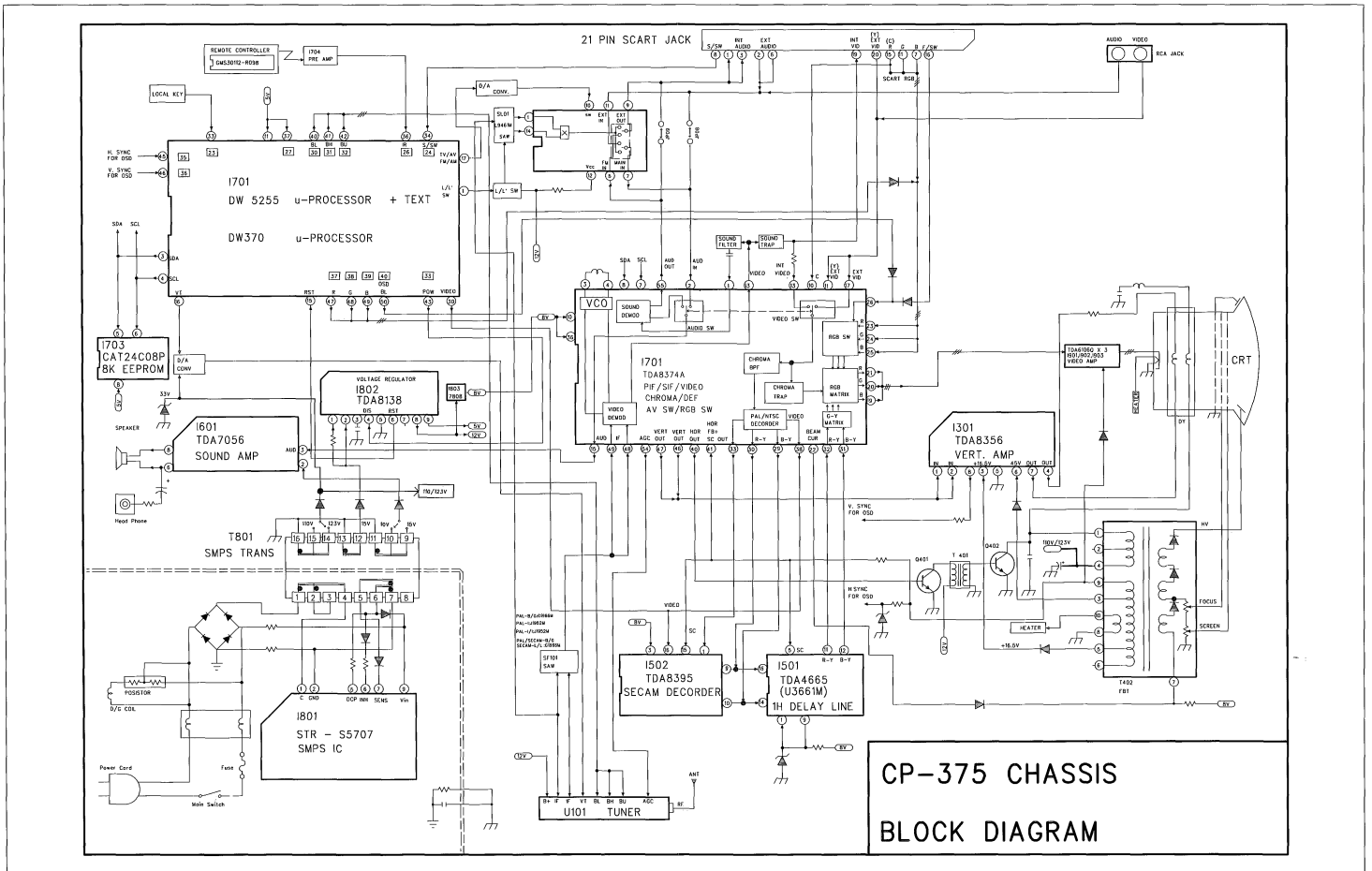

■ PRINTED CIRCUIT BOARD

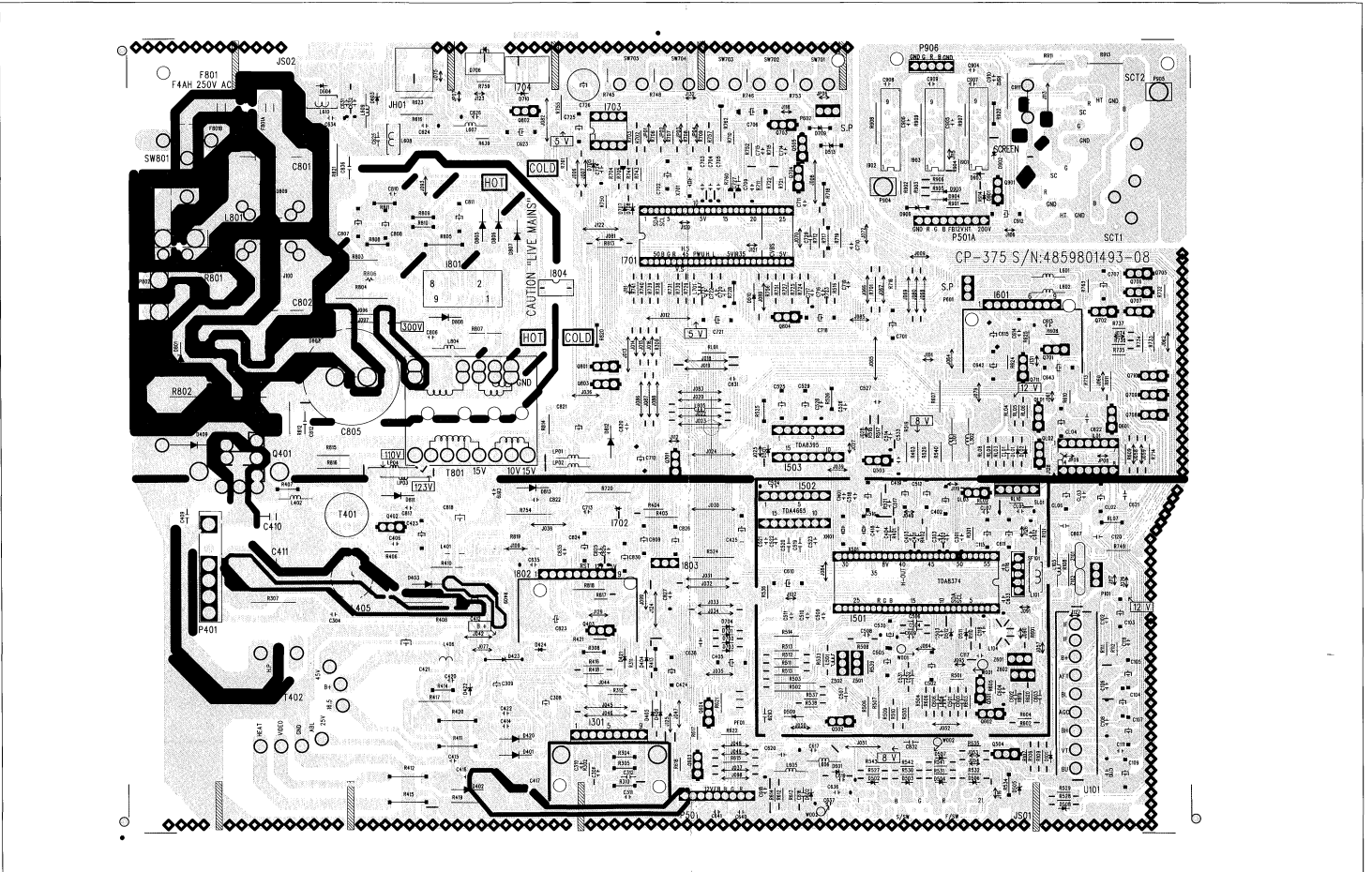

■ CP-375 CHASSIS SCHEMATIC DIAGRAM(HITACHI)

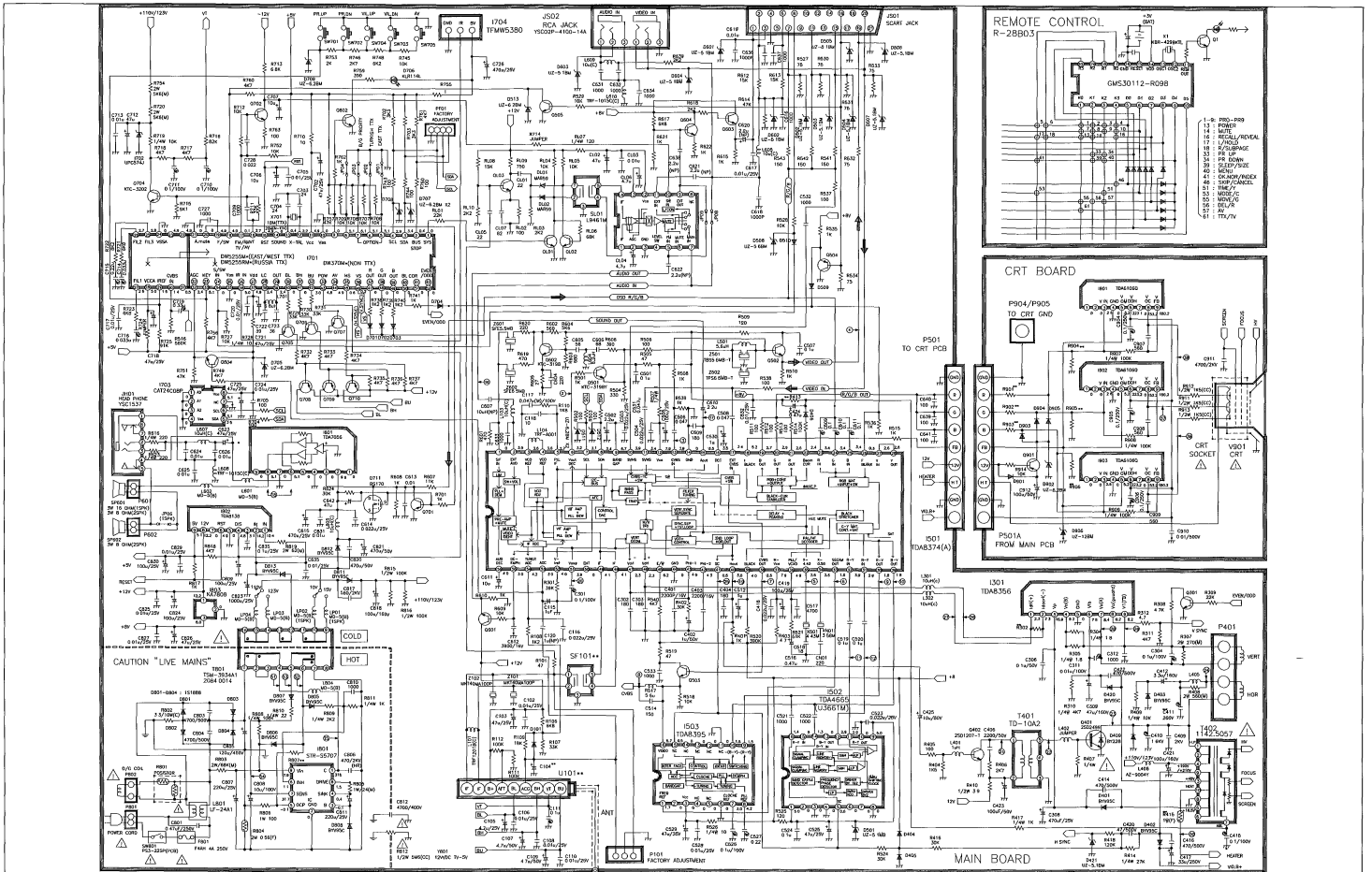

WAVE FORMS

SCHEMATIC DIAGRAM

CHASSIS : CP-375
(HITACHI)

- * PAL - B/G
- * PAL/SECAM - B/G, SECAM - L
- * PAL - I

NOTES :

- 1 ALL RESISTORS ARE 1/8W UNLESS OTHERWISE NOTED
- 2 CAPACITANCE VALUES 1 AND ABOVE ARE IN μ F EXCEPT AS INDICATED
- 3 INDUCTOR VALUES ARE IN μ H EXCEPT AS INDICATED
- 4 ALL DIODES ARE 1N4148 EXCEPT AS INDICATED
- 5 ALL NPN TRANSISTORS ARE KTC3198Y ALL PNP TRANSISTORS ARE KTA1266Y EXCEPT AS INDICATED
- 6 ALL THE DC VOLTAGES IN EACH POINT ARE MEASURED WITH DIGITAL VOLTMETER UNDER THE STANDARD PAL COLOR BAR SIGNAL INPUT (5 CHANNELS) AND ALL CONTROLS SET TO THE MAXIMUM POSITION AT NOMINAL LINE VOLTAGE AC 230V 50Hz
- 7 SINCE THIS SCHEMATIC DIAGRAM IS A STANDARD ONE THE CIRCUIT AND CIRCUIT COMPONENTS MAY BE SUBJECT TO CHANGE FOR IMPROVEMENT WITHOUT ANY NOTICE

SAFETY CAUTION :

BEFORE SERVICING THIS CHASSIS IT IS IMPORTANT THAT THE SERVICE TECHNICIAN READ FOLLOW THE "X-RAY RADIATION PRECAUTION "SAFETY PRECAUTION" AND "PRODUCT SAFETY NOTICE" IN THE SERVICE MANUAL.

PRODUCT SAFETY NOTE :

COMPONENTS MARKED WITH Δ ARE IMPORTANT FOR MAINTAINING THE SAFETY OF THE SET AND SHOULD BE REPLACED ONLY WITH TYPES IDENTICAL TO THE ORIGINAL OR SPECIFIED ONE IN THE PARTS LIST
DON'T DEGRADE THE SAFETY OF THE SET THROUGH IMPROPER SERVICING

WAVE FORMS

VIDEO : 8 STEP PAL COLOR BAR 87.5% AM
AUDIO : 1KHz SINE WAVE 60% FM

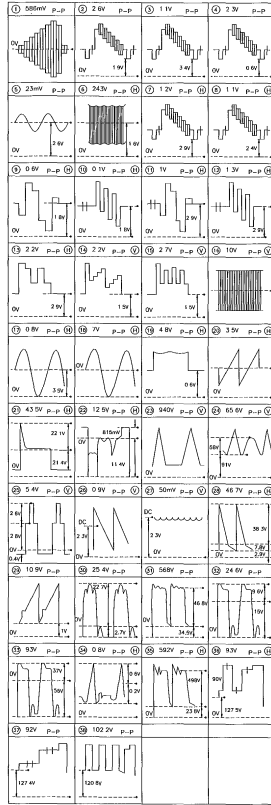

DIFFERENT PART FOR SYSTEM

NO	LOC	NAME	P-B/G	P-I	P/SECAM-L
1	PA01	POWER CORD	DA4232	DA3222	DA4232
2	LA01	TUNING	S3334AC	DT2-1117D	S3334AC
3	ST01	SIM FILTER	C1905W	JT922M	C1905W
4	Z801	CENA FILTER	TP55 5AB	TP54 0MB	TP55 5AB
5	Z801	CENA FILTER	SF3H 5ACB	SET4 0MB	SF3H5 5ACB
6	Z802	CENA FILTER	---	---	---
7	501	IC VCD	TD48374A	TD48374A	TD48374
8	505	IC SECAM	---	---	---
9	0705	TR	KTC3198C	---	KTC3198Y
10	Q106	TR	KTA1266Y	---	KTA1266Y
11	Q106	TR	KTA1266Y	---	KTA1266Y
12	Q109	TR	KTA1266Y	---	KTA1266Y
13	R929	R C-FILM	33K	---	33K
14	R920	R C-FILM	33K	---	33K
15	R932	R C-FILM	4.7K	---	4.7K
16	R933	R C-FILM	4.7K	---	4.7K
17	R935	R C-FILM	4.7K	---	4.7K
18	R937	R C-FILM	4.7K	---	4.7K
19	R938	R C-FILM	4.7K	---	4.7K
20	C105	C ELECTRO	50V 4.7u	---	50V 4.7u
21	C106	C ELECTRO	25V 0.01u	---	25V 0.01u
22	C107	C ELECTRO	50V 4.7u	---	50V 4.7u
23	C108	C CERA	25V 0.01u	---	25V 0.01u
24	Z101	CENA FILTER	---	---	MKT40M100P
25	Z102	CENA FILTER	---	---	MKT40M100P
26	LA01	IC AM DEMOD	---	---	S918225
27	SA01	SIM FILTER	---	---	L4615W
28	QA01	TR	---	---	KTC 3198Y
29	QA02	TR	---	---	KTC 3198Y
30	QA03	TR	---	---	KTC 3198Y
31	QA04	TR	---	---	KTC 3198Y
32	SA01	DIODE	---	---	MA959
33	CA01	DIODE	---	---	MA959
34	RL01	R C-FILM	---	---	22K
35	RL02	R C-FILM	---	---	10K
36	RL03	R C-FILM	---	---	2.2K
37	RL04	R C-FILM	---	---	10K
38	RL05	R C-FILM	---	---	10K
39	RL06	R C-FILM	---	---	60K
40	RL07	R C-FILM	---	---	1.74W 120
41	RL08	R C-FILM	---	---	15K
42	RL09	R C-FILM	---	---	750
43	RL10	R C-FILM	---	---	2.2K
44	RT11	R C-FILM	---	---	47
45	RT12	R C-FILM	---	---	10K
46	RT13	R C-FILM	---	---	6.8K
47	RT14	R C-FILM	---	---	10K
48	RT15	R C-FILM	---	---	100
49	CA01	C CERA	---	---	50V 22
50	CL02	C ELECTRO	---	---	50V 47u
51	CL03	C CERA	---	---	50V 0.01u
52	CL04	C ELECTRO	---	---	50V 4.7u
53	CL05	C CERA	---	---	50V 22
54	CL06	C ELECTRO	---	---	50V 4.7u
55	CL07	C CERA	---	---	50V 82
56	CT07	C ELECTRO	---	---	50V 10u
57	CT08	C CERA	---	---	50V 0.022u
58	JR08	WIRE COPPER	---	---	WIRE COPPER
59	JR09	WIRE COPPER	---	---	WIRE COPPER
60	JR10	WIRE COPPER	---	---	WIRE COPPER

DIFFERENT PARTS FOR CRT

NO	LOC	14"	20"	21"
1	CR1	CR14	CR20	CR21
2	SC11	SC14	SC20	SC21
3	SC12	---	---	---
4	B/C/OIL	DC-1450	DC-1450	DC-2050
5	JF04	MD-5	MD-5	MD-5
6	L103	L-125	L-102	L-125
7	L105	L-125	L-102	L-125
8	C409	20V 470	20V 470	20V 470
9	C410	1.6KV 7500	1.6KV 7500	1.6KV 7500
10	C411	200V 0.47	200V 0.51	200V 0.51
11	R302	1/8W 1.8K	1/8W 1.8K	1/8W 2.2K
12	R413	1/4W 150K	1/4W 150K	1/4W 82K
13	R410	1W 1.2K A	1W 0.47K	1W 2.0K A
14	R807	1W 2.4K	1W 2.4K	1W 2.7K
15	R801-3	1/8W 3K	1/8W 2.4K	1/8W 2K
16	R804-6	1/8W 2K	1/8W 2K	1/8W 1.6K
17	PA01	YF500-05	YF500-06	YF500-06
18	PA01A	YF500-05	YF500-06	YF500-06
19	Z113	1401H-1015-1P	1401H-1015-1P	1401H-1015-1P
20				
21				
22				

DIFFERENCE OF PARTS FOR OPTION

- TELETEXT OPTION

OPTION	WEST EUROPE TELETEXT	NON-TELETEXT
WEST EUROPE TELETEXT	DM3359A	DM3359A
NON-TELETEXT	DM370A	DM370A

- ANTENNA OPTION

MODEL	NAME	REMARK
PAL-B/G, P/SECAM-L	PH-PA-003	ROD ANTENNA
PAL-I	PH-PA-006	LOOP ANTENNA

CAPACITOR

ELECTRO	
CERAMIC	
CERAMIC CH	
TANTAL	
ELECTRO NONPOLAR	
MYLAR	

COIL

FEARING	
CHOKE	
BEAD	

RESISTOR

CARBON FILM	
M-CODE FILM	
CARBON COMP	
FUSIBLE	
CEMENT	

Electrical Parts List



Components marked with this symbol must only be replaced by a component having identical physical characteristics.

MODEL : CP1421T (PAL-B/G model with Teletext)

LOC.	PART-CODE	PART-NAME	PART-DESCRIPTION	REMARK
ZZ100	DE48B3228B03	TRANSMITTER REMOCON	R-28B03	
00030	DE47P7500001	BATTERY	AAM 1.5V	
ZZ131	DE58G0000084	COIL DEGAUSSING	DC-1450	△
ZZ132	DE48519A4610	CRT GROUND AS	1401H-1015-1P	
V901	DE4859605142	CRT	A34JLL90X01 (P38)	△
PA601	DE4850703S03	CONN AS	YH025-03+YST025+ULW=200	
SP01	DE4858306810	SPEAKER	3W 16 OHM F2035C03-3	
C102	DECCZF1E103Z	C CERA	25V F 0.01MF Z (AXIAL)	
C103	DECEXF1E470V	C ELECTRO	25V RSS 47MF (5X11) TP	
C104	DECEXF1H479V	C ELECTRO	50V RSS 4.7MF (5X11) TP	
C105	DECEXF1H479V	C ELECTRO	50V RSS 4.7MF (5X11) TP	
C106	DECCZF1E103Z	C CERA	25V F 0.01MF Z (AXIAL)	
C107	DECEXF1H479V	C ELECTRO	50V RSS 4 7MF (5X11) TP	
C108	DECCZF1E103Z	C CERA	25V F 0.01MF Z (AXIAL)	
C109	DECEXF1H479V	C ELECTRO	50V RSS 4.7MF (5X11) TP	
C110	DECCZF1E103Z	C CERA	25V F 0.01MF Z (AXIAL)	
C111	DECMXM2A104J	C MYLAR	100V 0.1MF J (TP)	
C115	DECEXF1H109V	C ELECTRO	50V RSS 1MF (5X11) TP	
C116	DECCZF1E223Z	C CERA	25V F 0.022MF Z (AXIAL)	
C117	DECMXM2A473J	C MYLAR	100V 0 047MF J (TP)	
C118	DECZCH1H100J	C CERA	50V CH 10PF J (AXIAL)	
C120	DECEXD1H109F	C ELECTRO	50V RND 1MF (5X11) TP	
C301	DECMXB2A104J	C MYLAR	100V EU 0.1MF J (TP)	
C302	DECCZB1H181K	C CERA	50V B 180PF K (AXIAL)	
C303	DECCZB1H181K	C CERA	50V B 180PF K (AXIAL)	
C304	DECMXM2A104J	C MYLAR	100V 0.1MF J (TP)	
C306	DECBXF1H104Z	C CERA SEMI	50V F 0 1MF Z (TAPPING)	
C308	DECEXF1E471V	C ELECTRO	25V RSS 470MF (10X16) TP	
C309	DECEXF2A470V	C ELECTRO	100V RSS 47MF (10X16) TP	
C311	DECMXM2A103J	C MYLAR	100V 0 01MF J (TP)	
C312	DECCZB1H102K	C CERA	50V B 1000PF K (AXIAL)	
C401	DECBZR1C472M	C CERA	16V Y5R 4700PF M (AXIAL)	
C402	DECEXF1H109V	C ELECTRO	50V RSS 1MF (5X11) TP	
C403	DECBZR1C222M	C CERA	16V Y5R 2200PF M (AXIAL)	
C404	DECCZB1H181K	C CERA	50V B 180PF K (AXIAL)	
C406	DECCXB1H222K	C CERA	50V B 2200PF K (TAPPING)	
C409	DECCXB3D471K	C CERA	2KV B 470PF K (TAPPING)	△
C410	DECMYH3C752J	C MYLAR	1.6KV BUP 7500PF J	△
C411	DECMYE2D474J	C MYLAR	200V PU 0 47MF J	△
C412	DECEXF2C339V	C ELECTRO	160V RSS 3.3MF (8X16) TP	
C414	DECCXB2H471K	C CERA	500V B 470PF K (TAPPING)	
C415	DECMXM2A104J	C MYLAR	100V 0.1MF J (TP)	
C416	DECCXB2H471K	C CERA	500V B 470PF K (TAPPING)	
C417	DECEXF2E330V	C ELECTRO	250V RSS 33MF (13X25) TP	
C418	DECCZF1E223Z	C CERA	25V F 0 022MF Z (AXIAL)	
C419	DECEXF1C101V	C ELECTRO	16V RSS 100MF (6 3X11) TP	
C420	DECXSL2H470J	C CERA	500V SL 47PF J (TAPPING)	
C421	DECEXF2C101V	C ELECTRO	160V RSS 100MF (16X25) TP	



LOC.	PART-CODE	PART-NAME	PART-DESCRIPTION	REMARK
C422	DECCXB2H471K	C CERA	500V B 470PF K (TAPPING)	
C423	DECEXF1E101V	C ELECTRO	25V RSS 100MF (6.3X11) TP	
C424	DECEXF1H478V	C ELECTRO	50V RSS 0.47MF (5X11) TP	
C425	DECEXF1H100V	C ELECTRO	50V RSS 10MF (5X11) TP	
C501	DECBZF1H104Z	C CERA SEMI	50V F 0.1MF Z (AXIAL)	
C502	DECEXF1H229V	C ELECTRO	50V RSS 2.2MF (5X11) TP	
C503	DECCZF1E223Z	C CERA	25V F 0.022MF Z (AXIAL)	
C504	DECCZF1E223Z	C CERA	25V F 0.022MF Z (AXIAL)	
C505	DECEXF1C101V	C ELECTRO	16V RSS 100MF (6.3X11) TP	
C506	DECCZF1H473Z	C CERA	50V F 0.047MF Z (AXIAL)	
C507	DECBZF1H104Z	C CERA SEMI	50V F 0.1MF Z (AXIAL)	
C508	DECCZF1H473Z	C CERA	50V F 0.047MF Z (AXIAL)	
C509	DECMXM2A104J	C MYLAR	100V 0.1MF J (TP)	
C510	DECMXM2A104J	C MYLAR	100V 0.1MF J (TP)	
C511	DECMXM2A104J	C MYLAR	100V 0.1MF J (TP)	
C512	DECEXF1H109V	C ELECTRO	50V RSS 1MF (5X11) TP	
C514	DECCZB1H151K	C CERA	50V B 150PF K (AXIAL)	
C516	DECEXF1H478V	C ELECTRO	50V RSS 0.47MF (5X11) TP	
C517	DECBZR1C472M	C CERA	16V Y5R 4700PF M (AXIAL)	
C518	DECZCH1H180J	C CERA	50V CH 18PF J (AXIAL)	
C519	DECBZF1H104Z	C CERA SEMI	50V F 0.1MF Z (AXIAL)	
C520	DECBZF1H104Z	C CERA SEMI	50V F 0.1MF Z (AXIAL)	
C521	DECCZB1H102K	C CERA	50V B 1000PF K (AXIAL)	
C522	DECCZB1H102K	C CERA	50V B 1000PF K (AXIAL)	
C523	DECCZF1E223Z	C CERA	25V F 0.022MF Z (AXIAL)	
C524	DECBZF1H104Z	C CERA SEMI	50V F 0.1MF Z (AXIAL)	
C525	DECEXF1C470V	C ELECTRO	16V RSS 47MF (5X11) TP	
C526	DECMXM2A104J	C MYLAR	100V 0.1MF J (TP)	
C527	DECMXB1H224J	C MYLAR	50V EU 0.22MF J (TP)	
C528	DECCZF1E103Z	C CERA	25V F 0.01MF Z (AXIAL)	
C529	DECEXF1C470V	C ELECTRO	16V RSS 47MF (5X11) TP	
C530	DECEXF1H109V	C ELECTRO	50V RSS 1MF (5X11) TP	
C531	DECCZF1H473Z	C CERA	50V F 0.047MF Z (AXIAL)	
C532	DECCZB1H102K	C CERA	50V B 1000PF K (AXIAL)	
C533	DECCZB1H102K	C CERA	50V B 1000PF K (AXIAL)	
C604	DECCZB1H221K	C CERA	50V B 220PF K (AXIAL)	
C605	DECZSL1H560J	C CERA	50V SL 56PF J (AXIAL)	
C606	DECZSL1H680J	C CERA	50V SL 68PF J (AXIAL)	
C607	DECEXD1H100F	C ELECTRO	50V RND 10MF (8X11.5) TP	
C609	DECCZB1H181K	C CERA	50V B 180PF K (AXIAL)	
C610	DECEXF1H229V	C ELECTRO	50V RSS 2.2MF (5X11) TP	
C611	DECEXF1H100V	C ELECTRO	50V RSS 10MF (5X11) TP	
C612	DECBZR1C392M	C CERA	16V Y5R 3900PF M (AXIAL)	
C613	DECCZF1E103Z	C CERA	25V F 0.01MF Z (AXIAL)	
C614	DECCZF1E223Z	C CERA	25V F 0.022MF Z (AXIAL)	
C615	DECEXF1E471V	C ELECTRO	25V RSS 470MF (10X16) TP	
C616	DECCZB1H102K	C CERA	50V B 1000PF K (AXIAL)	
C617	DECCZF1E103Z	C CERA	25V F 0.01MF Z (AXIAL)	
C618	DECCZB1H102K	C CERA	50V B 1000PF K (AXIAL)	
C619	DECCZF1E103Z	C CERA	25V F 0.01MF Z (AXIAL)	
C620	DECEXD1H229F	C ELECTRO	50V RND 2.2MF (5X11) TP	
C621	DECEXD1H229F	C ELECTRO	50V RND 2.2MF (5X11) TP	
C622	DECEXD1H229F	C ELECTRO	50V RND 2.2MF (5X11) TP	

LOC.	PART-CODE	PART-NAME	PART-DESCRIPTION	REMARK
C623	DECEXF1E470V	C ELECTRO	25V RSS 47MF (5X11) TP	
C624	DECCZF1E103Z	C CERA	25V F 0 01MF Z (AXIAL)	
C625	DECCZF1E103Z	C CERA	25V F 0.01MF Z (AXIAL)	
C626	DECCZF1E103Z	C CERA	25V F 0 01MF Z (AXIAL)	
C631	DECCZB1H102K	C CERA	50V B 1000PF K (AXIAL)	
C632	DECCZB1H102K	C CERA	50V B 1000PF K (AXIAL)	
C633	DECCZB1H102K	C CERA	50V B 1000PF K (AXIAL)	
C634	DECCZB1H102K	C CERA	50V B 1000PF K (AXIAL)	
C635	DECCZF1E103Z	C CERA	25V F 0 01MF Z (AXIAL)	
C636	DECCZB1H102K	C CERA	50V B 1000PF K (AXIAL)	
C637	DECCZB1H102K	C CERA	50V B 1000PF K (AXIAL)	
C638	DECEXD1H229F	C ELECTRO	50V RND 2.2MF (5X11) TP	
C639	DECCZB1H101K	C CERA	50V B 100PF K (AXIAL)	
C640	DECCZB1H101K	C CERA	50V B 100PF K (AXIAL)	
C641	DECCZB1H101K	C CERA	50V B 100PF K (AXIAL)	
C642	DECEXF1E470V	C ELECTRO	25V RSS 47MF (5X11) TP	
C702	DECEXF1C470V	C ELECTRO	16V RSS 47MF (5X11) TP	
C703	DECZSL1H240J	C CERA	50V SL 24PF J (AXIAL)	
C704	DECZSL1H240J	C CERA	50V SL 24PF J (AXIAL)	
C705	DECCZF1E103Z	C CERA	25V F 0.01MF Z (AXIAL)	
C706	DECEXF1H100V	C ELECTRO	50V RSS 10MF (5X11) TP	
C709	DECCZB1H102K	C CERA	50V B 1000PF K (AXIAL)	
C710	DECMXM2A104J	C MYLAR	100V 0.1MF J (TP)	
C711	DECMXM2A104J	C MYLAR	100V 0 1MF J (TP)	
C712	DECEXF1H470V	C ELECTRO	50V RSS 47MF (6 3X11) TP	
C713	DECCXF1H103Z	C CERA	50V F 0 01MF Z (TAPPING)	
C714	DECMXB1H333J	C MYLAR	50V EU 0 033MF J (TP)	
C715	DECMXB1H224J	C MYLAR	50V EU 0 22MF J (TP)	
C716	DECMXB1H333J	C MYLAR	50V EU 0.033MF J (TP)	
C717	DECCZF1E103Z	C CERA	25V F 0 01MF Z (AXIAL)	
C718	DECEXF1C470V	C ELECTRO	16V RSS 47MF (5X11) TP	
C719	DECMXB1H334J	C MYLAR	50V EU 0.33MF J (TP)	
C720	DECCZF1E103Z	C CERA	25V F 0.01MF Z (AXIAL)	
C721	DECEXF1C470V	C ELECTRO	16V RSS 47MF (5X11) TP	
C722	DECXCH1H390J	C CERA	50V CH 39PF J (TAPPING)	
C723	DECXCH1H360J	C CERA	50V CH 36PF J (TAPPING)	
C724	DECCZF1E103Z	C CERA	25V F 0 01MF Z (AXIAL)	
C725	DECEXF1C470V	C ELECTRO	16V RSS 47MF (5X11) TP	
C726	DECEXF1C102V	C ELECTRO	16V RSS 1000MF (10X20) TP	
C727	DECCZB1H102K	C CERA	50V B 1000PF K (AXIAL)	
C801	DECL1JB3474K	C LINE ACROSS	AC250V 0.47MF U/C/SNDF/SV	△
C802	DECL1JB3474K	C LINE ACROSS	AC250V 0.47MF U/C/SNDF/SV	△
C803	DECCXE2H472P	C CERA	500V E 4700PF P (TAPPING)	△
C804	DECCXE2H472P	C CERA	500V E 4700PF P (TAPPING)	△
C805	DECEYM2G121T	C ELECTRO	400V LWF 120MF (25X50)	△
C806	DECCYR3D471K	C CERA	HIKR 2KV 470PF K 125C	△
C807	DECEXF1E221V	C ELECTRO	25V RSS 220MF (8X11.5) TP	
C808	DECEXF2A100V	C ELECTRO	100V RSS 10MF (6.3X11) TP	
C809	DECEXF1C101V	C ELECTRO	16V RSS 100MF (6.3X11) TP	
C810	DECCZB1H102K	C CERA	50V B 1000PF K (AXIAL)	
C811	DECEXF1E221V	C ELECTRO	25V RSS 220MF (8X11.5) TP	
C812	DECH1FFE472M	C CERA AC	4.0KV 4700PF M KD AC250V	
C817	DECCYB3D561K	C CERA	2KV B 560PF K	△

LOC.	PART-CODE	PART-NAME	PART-DESCRIPTION	REMARK
C818	DECEXF2C101V	C ELECTRO	160V RSS 100MF (16X25) TP	
C821	DECEXF1E471V	C ELECTRO	25V RSS 470MF (10X16) TP	
C823	DECEXF1E102C	C ELECTRO	25V RUS 1000MF (13X20) TP	
C824	DECEXF1E101C	C ELECTRO	25V RUS 100MF (6.3X11) TP	
C825	DECCZF1E103Z	C CERA	25V F 0.01MF Z (AXIAL)	
C826	DECEXF1C470C	C ELECTRO	16V RUS 47MF (5X11) TP	
C827	DECCZF1E103Z	C CERA	25V F 0.01MF Z (AXIAL)	
C829	DECCZF1E103Z	C CERA	25V F 0.01MF Z (AXIAL)	
C830	DECEXF1C101C	C ELECTRO	16V RUS 100MF (6.3X11) TP	
C831	DECCXF1H103Z	C CERA	50V F 0.01MF Z (TAPPING)	
C832	DECCZF1E103Z	C CERA	25V F 0.01MF Z (AXIAL)	
C835	DECCZF1H104Z	C CERA SEMI	50V F 0.1MF Z (AXIAL)	
C904	DECMXL2E104K	C MYLAR	250V MEU 0.1MF K	
C905	DECMXL2E104K	C MYLAR	250V MEU 0.1MF K	
C906	DECMXL2E104K	C MYLAR	250V MEU 0.1MF K	
C907	DECCXB1H561K	C CERA	50V B 560PF K (TAPPING)	
C908	DECCXB1H561K	C CERA	50V B 560PF K (TAPPING)	
C909	DECCXB1H561K	C CERA	50V B 560PF K (TAPPING)	
C910	DECCXF2H103Z	C CERA	HIKF 500V 0.01MF Z	
C911	DECCYB3D472K	C CERA	2KV B 4700PF K	
C912	DECEXF1E101V	C ELECTRO	25V RSS 100MF (6.3X11) TP	
D101	DED1N4148—	DIODE	1N4148 (TAPPING)	
D401	DEDBYV95C—	DIODE	BYV95C (TAPPING)	△
D402	DEDBYV95C—	DIODE	BYV95C (TAPPING)	△
D403	DEDBYV95C—	DIODE	BYV95C (TAPPING)	△
D404	DED1N4148—	DIODE	1N4148 (TAPPING)	
D405	DED1N4148—	DIODE	1N4148 (TAPPING)	
D406	DED1N4148—	DIODE	1N4148 (TAPPING)	
D409	DEDBY228—	DIODE	BY228 (TAPPING)	△
D420	DEDBYV95C—	DIODE	BYV95C (TAPPING)	△
D421	DEDUZ5R1BM—	DIODE ZENER	UZ-5 1BM	
D501	DEDUZ5R1BM—	DIODE ZENER	UZ-5 1BM	
D502	DEDUZ5R1BM—	DIODE ZENER	UZ-5.1BM	
D503	DEDUZ5R1BM—	DIODE ZENER	UZ-5.1BM	
D504	DEDUZ5R1BM—	DIODE ZENER	UZ-5.1BM	
D505	DEDUZ5R1BM—	DIODE ZENER	UZ-5 1BM	
D506	DEDUZ5R1BM—	DIODE ZENER	UZ-5.1BM	
D507	DEDUZ5R1BM—	DIODE ZENER	UZ-5.1BM	
D508	DEDMTZ5R6B—	DIODE ZENER	MTZ 5 6-B (TAPPING)	
D509	DED1N4148—	DIODE	1N4148 (TAPPING)	
D510	DED1N4148—	DIODE	1N4148 (TAPPING)	
D511	DEDUZ6R2BM—	DIODE ZENER	UZ-6.2BM 6.2V	
D512	DEDUZ6R2BM—	DIODE ZENER	UZ-6.2BM 6.2V	
D513	DEDUZ6R2BM—	DIODE ZENER	UZ-6.2BM 6.2V	
D601	DEDUZ5R1BM—	DIODE ZENER	UZ-5 1BM	
D602	DEDUZ5R1BM—	DIODE ZENER	UZ-5 1BM	
D603	DEDUZ5R1BM—	DIODE ZENER	UZ-5.1BM	
D604	DEDUZ5R1BM—	DIODE ZENER	UZ-5 1BM	
D701	DED1N4148—	DIODE	1N4148 (TAPPING)	
D702	DED1N4148—	DIODE	1N4148 (TAPPING)	
D703	DED1N4148—	DIODE	1N4148 (TAPPING)	
D704	DED1N4148—	DIODE	1N4148 (TAPPING)	
D705	DEDUZ6R2BM—	DIODE ZENER	UZ-6.2BM 6.2V	

LOC.	PART-CODE	PART-NAME	PART-DESCRIPTION	REMARK
D706	DEDKLR114L—	LED	KLR114L	
D707	DEDUZ6R2BM—	DIODE ZENER	UZ-6 2BM 6.2V	
D708	DEDUZ6R2BM—	DIODE ZENER	UZ-6.2BM 6.2V	
D709	DEDUZ6R2BM—	DIODE ZENER	UZ-6.2BM 6.2V	
D801	DED1S1888—	DIODE	1S1888 (TAPPING)	△
D802	DED1S1888—	DIODE	1S1888 (TAPPING)	△
D803	DED1S1888—	DIODE	1S1888 (TAPPING)	△
D804	DED1S1888—	DIODE	1S1888 (TAPPING)	△
D805	DEDBYV95C—	DIODE	BYV95C (TAPPING)	△
D806	DEDBYV95C—	DIODE	BYV95C (TAPPING)	△
D807	DEDBYV95C—	DIODE	BYV95C (TAPPING)	△
D808	DEDBYV95C—	DIODE	BYV95C (TAPPING)	△
D811	DEDBYV95C—	DIODE	BYV95C (TAPPING)	△
D812	DEDBYV95C—	DIODE	BYV95C (TAPPING)	△
D813	DEDBYV95C—	DIODE	BYV95C (TAPPING)	△
D901	DED1N4148—	DIODE	1N4148 (TAPPING)	
D902	DEDUZ6R2BM—	DIODE ZENER	UZ-6.2BM 6.2V	
D903	DED1N4148—	DIODE	1N4148 (TAPPING)	
D904	DED1N4148—	DIODE	1N4148 (TAPPING)	
D905	DED1N4148—	DIODE	1N4148 (TAPPING)	
D906	DEDMTZ12C—	DIODE ZENER	MTZ-12C	
F801	DE5FSCB4022R	FUSE CERA	SEMKO F4AH 4A 250V MF51	△
F801A	DE4857415001	CLIP FUSE	PFC5000-0702	△
F801B	DE4857415001	CLIP FUSE	PFC5000-0702	△
I301	DE1TDA8356—	IC VERTICAL	TDA8356	
I301A	DE4857024617	HEAT SINK	AL EX	
I301B	DE7174300811	SCREW TAPPTITE	TT2 RND 3X8 MFZN	
I501	DE1TDA8374A-	IC VCD	TDA8374A	
I502	DE1TDA4665V4	IC DELAY	TDA4665/V4	
I601	DE1TDA7056—	IC	TDA7056	
I701	DE1DW5255M4-	IC MICOM	DW5255M4	
I702	DE1UPC574J—	IC	UPC574J	
I703	DE124LC08B—	IC MEMORY	24LC08B	
I704	DE1TFMW5380-	IC PREAMP	TFMW5380	
I801	DE1STRS5707-	IC POWER	STR-S5707	△
I802	DE1TDA8138—	IC REGULATOR	TDA8138	
I802A	DE4857025401	HEAT SINK	A1050P-H24 T2	
I802B	DE7174300811	SCREW TAPPTITE	TT2 RND 3X8 MFZN	
I803	DE1KA7808—	IC REGULATOR	KA7808	
I901	DE1TDA6106Q-	IC AMP	TDA6106Q	
I902	DE1TDA6106Q-	IC AMP	TDA6106Q	
I903	DE1TDA6106Q-	IC AMP	TDA6106Q	
J006	DE85801065GY	WIRE COPPER	AWG22 1/0.65 TIN COATING	
J007	DE85801065GY	WIRE COPPER	AWG22 1/0.65 TIN COATING	
J008	DE85801065GY	WIRE COPPER	AWG22 1/0 65 TIN COATING	
J009	DE85801065GY	WIRE COPPER	AWG22 1/0.65 TIN COATING	
J012	DE85801065GY	WIRE COPPER	AWG22 1/0 65 TIN COATING	
J013	DE85801065GY	WIRE COPPER	AWG22 1/0 65 TIN COATING	
J014	DE85801065GY	WIRE COPPER	AWG22 1/0.65 TIN COATING	
J015	DE85801065GY	WIRE COPPER	AWG22 1/0.65 TIN COATING	
J016	DE85801065GY	WIRE COPPER	AWG22 1/0.65 TIN COATING	
J018	DE85801065GY	WIRE COPPER	AWG22 1/0 65 TIN COATING	
J019	DE85801065GY	WIRE COPPER	AWG22 1/0.65 TIN COATING	

LOC.	PART-CODE	PART-NAME	PART-DESCRIPTION	REMARK
J020	DE85801065GY	WIRE COPPER	AWG22 1/0.65 TIN COATING	
J022	DE85801065GY	WIRE COPPER	AWG22 1/0.65 TIN COATING	
J023	DE85801065GY	WIRE COPPER	AWG22 1/0 65 TIN COATING	
J024	DE85801065GY	WIRE COPPER	AWG22 1/0.65 TIN COATING	
J025	DE85801065GY	WIRE COPPER	AWG22 1/0.65 TIN COATING	
J027	DE85801065GY	WIRE COPPER	AWG22 1/0.65 TIN COATING	
J028	DE85801065GY	WIRE COPPER	AWG22 1/0.65 TIN COATING	
J030	DE85801065GY	WIRE COPPER	AWG22 1/0.65 TIN COATING	
J031	DE85801065GY	WIRE COPPER	AWG22 1/0.65 TIN COATING	
J032	DE85801065GY	WIRE COPPER	AWG22 1/0.65 TIN COATING	
J033	DE85801065GY	WIRE COPPER	AWG22 1/0.65 TIN COATING	
J034	DE85801065GY	WIRE COPPER	AWG22 1/0.65 TIN COATING	
J035	DE85801065GY	WIRE COPPER	AWG22 1/0 65 TIN COATING	
J036	DE85801065GY	WIRE COPPER	AWG22 1/0 65 TIN COATING	
J037	DE85801065GY	WIRE COPPER	AWG22 1/0.65 TIN COATING	
J038	DE85801065GY	WIRE COPPER	AWG22 1/0.65 TIN COATING	
J039	DE85801065GY	WIRE COPPER	AWG22 1/0.65 TIN COATING	
J040	DE85801065GY	WIRE COPPER	AWG22 1/0 65 TIN COATING	
J042	DE85801065GY	WIRE COPPER	AWG22 1/0.65 TIN COATING	
J044	DE85801065GY	WIRE COPPER	AWG22 1/0 65 TIN COATING	
J045	DE85801065GY	WIRE COPPER	AWG22 1/0.65 TIN COATING	
J046	DE85801065GY	WIRE COPPER	AWG22 1/0.65 TIN COATING	
J047	DE85801065GY	WIRE COPPER	AWG22 1/0.65 TIN COATING	
J048	DE85801065GY	WIRE COPPER	AWG22 1/0.65 TIN COATING	
J049	DE85801065GY	WIRE COPPER	AWG22 1/0.65 TIN COATING	
J050	DE85801065GY	WIRE COPPER	AWG22 1/0.65 TIN COATING	
J051	DE85801065GY	WIRE COPPER	AWG22 1/0.65 TIN COATING	
J052	DE85801065GY	WIRE COPPER	AWG22 1/0.65 TIN COATING	
J053	DE85801065GY	WIRE COPPER	AWG22 1/0.65 TIN COATING	
J054	DE85801065GY	WIRE COPPER	AWG22 1/0.65 TIN COATING	
J057	DE85801065GY	WIRE COPPER	AWG22 1/0.65 TIN COATING	
J058	DE85801065GY	WIRE COPPER	AWG22 1/0.65 TIN COATING	
J059	DE85801065GY	WIRE COPPER	AWG22 1/0.65 TIN COATING	
J060	DE85801065GY	WIRE COPPER	AWG22 1/0.65 TIN COATING	
J061	DE85801065GY	WIRE COPPER	AWG22 1/0.65 TIN COATING	
J062	DE85801065GY	WIRE COPPER	AWG22 1/0.65 TIN COATING	
J063	DE85801065GY	WIRE COPPER	AWG22 1/0.65 TIN COATING	
J064	DE85801065GY	WIRE COPPER	AWG22 1/0.65 TIN COATING	
J065	DE85801065GY	WIRE COPPER	AWG22 1/0.65 TIN COATING	
J066	DE85801065GY	WIRE COPPER	AWG22 1/0 65 TIN COATING	
J067	DE85801065GY	WIRE COPPER	AWG22 1/0 65 TIN COATING	
J068	DE85801065GY	WIRE COPPER	AWG22 1/0.65 TIN COATING	
J069	DE85801065GY	WIRE COPPER	AWG22 1/0.65 TIN COATING	
J070	DE85801065GY	WIRE COPPER	AWG22 1/0.65 TIN COATING	
J072	DE85801065GY	WIRE COPPER	AWG22 1/0.65 TIN COATING	
J074	DE85801065GY	WIRE COPPER	AWG22 1/0.65 TIN COATING	
J075	DE85801065GY	WIRE COPPER	AWG22 1/0.65 TIN COATING	
J076	DE85801065GY	WIRE COPPER	AWG22 1/0.65 TIN COATING	
J077	DE85801065GY	WIRE COPPER	AWG22 1/0.65 TIN COATING	
J080	DE85801065GY	WIRE COPPER	AWG22 1/0.65 TIN COATING	
J081	DE85801065GY	WIRE COPPER	AWG22 1/0.65 TIN COATING	
J082	DE85801065GY	WIRE COPPER	AWG22 1/0.65 TIN COATING	
J083	DE85801065GY	WIRE COPPER	AWG22 1/0.65 TIN COATING	

LOC.	PART-CODE	PART-NAME	PART-DESCRIPTION	REMARK
J084	DE85801065GY	WIRE COPPER	AWG22 1/0 65 TIN COATING	
J085	DE85801065GY	WIRE COPPER	AWG22 1/0.65 TIN COATING	
J086	DE85801065GY	WIRE COPPER	AWG22 1/0 65 TIN COATING	
J087	DE85801065GY	WIRE COPPER	AWG22 1/0.65 TIN COATING	
J088	DE85801065GY	WIRE COPPER	AWG22 1/0.65 TIN COATING	
J089	DE85801065GY	WIRE COPPER	AWG22 1/0.65 TIN COATING	
J090	DE85801065GY	WIRE COPPER	AWG22 1/0.65 TIN COATING	
J091	DE85801065GY	WIRE COPPER	AWG22 1/0.65 TIN COATING	
J093	DE85801065GY	WIRE COPPER	AWG22 1/0 65 TIN COATING	
J094	DE85801065GY	WIRE COPPER	AWG22 1/0.65 TIN COATING	
J095	DE85801065GY	WIRE COPPER	AWG22 1/0.65 TIN COATING	
J096	DE85801065GY	WIRE COPPER	AWG22 1/0.65 TIN COATING	
J097	DE85801065GY	WIRE COPPER	AWG22 1/0.65 TIN COATING	
J098	DE85801065GY	WIRE COPPER	AWG22 1/0.65 TIN COATING	
J099	DE85801065GY	WIRE COPPER	AWG22 1/0.65 TIN COATING	
J100	DE85801065GY	WIRE COPPER	AWG22 1/0.65 TIN COATING	
J101	DE85801065GY	WIRE COPPER	AWG22 1/0.65 TIN COATING	
J102	DE85801065GY	WIRE COPPER	AWG22 1/0.65 TIN COATING	
J106	DE85801065GY	WIRE COPPER	AWG22 1/0.65 TIN COATING	
J109	DE85801065GY	WIRE COPPER	AWG22 1/0 65 TIN COATING	
J111	DE85801065GY	WIRE COPPER	AWG22 1/0.65 TIN COATING	
J112	DE85801065GY	WIRE COPPER	AWG22 1/0 65 TIN COATING	
J113	DE85801065GY	WIRE COPPER	AWG22 1/0.65 TIN COATING	
J115	DE85801065GY	WIRE COPPER	AWG22 1/0.65 TIN COATING	
J116	DE85801065GY	WIRE COPPER	AWG22 1/0.65 TIN COATING	
J117	DE85801065GY	WIRE COPPER	AWG22 1/0.65 TIN COATING	
J118	DE85801065GY	WIRE COPPER	AWG22 1/0.65 TIN COATING	
J119	DE85801065GY	WIRE COPPER	AWG22 1/0.65 TIN COATING	
J123	DE85801065GY	WIRE COPPER	AWG22 1/0 65 TIN COATING	
J124	DE85801065GY	WIRE COPPER	AWG22 1/0.65 TIN COATING	
J125	DE85801065GY	WIRE COPPER	AWG22 1/0 65 TIN COATING	
J126	DE85801065GY	WIRE COPPER	AWG22 1/0.65 TIN COATING	
J127	DE85801065GY	WIRE COPPER	AWG22 1/0 65 TIN COATING	
J128	DE85801065GY	WIRE COPPER	AWG22 1/0 65 TIN COATING	
J131	DE85801065GY	WIRE COPPER	AWG22 1/0 65 TIN COATING	
JH01	DE4859102130	JACK EARPHONE	YSC-1537	
JP06	DE85801065GY	WIRE COPPER	AWG22 1/0.65 TIN COATING	
JP08	DE85801065GY	WIRE COPPER	AWG22 1/0.65 TIN COATING	
JP09	DE85801065GY	WIRE COPPER	AWG22 1/0.65 TIN COATING	
JS01	DE4859200401	SOCKET RGB	SR-21A1 (ANGLE TYPE)	
JS02	DE4859108350	JACK PIN BOARD	YSC02P-4100-14A	
L101	DE58C9780027	COIL CHOKE	TRF-1201B (0.97 UH)	
L103	DE5CPZ100K04	COIL PEAKING	10UH 10.5MM K (LAL04TB)	
L104	DE58E0000S37	COIL AFT	TRF-A001	
L301	DE5CPZ100K04	COIL PEAKING	10UH 10 5MM K (LAL04TB)	
L302	DE5CPZ100K04	COIL PEAKING	10UH 10.5MM K (LAL04TB)	
L401	DE5CPZ109M02	COIL PEAKING	1UH M (AXIAL 3.5MM)	
L402	DE85801065GY	WIRE COPPER	AWG22 1/0 65 TIN COATING	
L405	DE58H0000018	COIL H-LINEARITY	L-125 (125UH)	
L406	DE58C9430599	COIL CHOKE	AZ-9004Y(94MH)	
L501	DE5CPZ569K02	COIL PEAKING	5 6UH K (AXIAL 3 5MM)	
L601	DE5MC0000100	COIL BEAD	MD-5 (HC-3550)	
L602	DE5MC0000100	COIL BEAD	MD-5 (HC-3550)	

LOC.	PART-CODE	PART-NAME	PART-DESCRIPTION	REMARK
L604	DE5CPZ829K02	COIL PEAKING	8.2UH K (AXIAL 3.5MM)	
L605	DE5CPZ100K04	COIL PEAKING	10UH 10.5MM K (LAL04TB)	
L606	DE5CPZ100K04	COIL PEAKING	10UH 10 5MM K (LAL04TB)	
L607	DE5CPZ100K04	COIL PEAKING	10UH 10 5MM K (LAL04TB)	
L608	DE58C6R8J067	COIL CHOKE	TRF-1015C (6.8UH J)	
L609	DE5CPZ100K04	COIL PEAKING	10UH 10.5MM K (LAL04TB)	
L610	DE58C6R8J067	COIL CHOKE	TRF-1015C (6 8UH J)	
L701	DE5CPZ689K02	COIL PEAKING	6 8UH K (AXIAL 3.5MM)	
L801	DE5PLF24A1—	FILTER LINE	LF-24A1	△
L804	DE5MC0000100	COIL BEAD	MD-5 (HC-3550)	
L805	DE5CPZ100K04	COIL PEAKING	10UH 10.5MM K (LAL04TB)	
LP02	DE5MC0000100	COIL BEAD	MD-5 (HC-3550)	
LP03	DE5MC0000100	COIL BEAD	MD-5 (HC-3550)	
M681	DE4856818300	CLAMP WIRE	PH-WL-5034	
M721	DE4857235802	SHIELD CASE	"SPTH-C ("B+C") HOLE"	
P101	DE485923162S	CONN WAFER	YW025-03 (STICK)	
P401	DE4859240020	CONN WAFER	YFW500-05	
P501	DE485923522S	CONN WAFER	YW025-09 (STICK)	
P501A	DE4850709S02	CONN AS	YH025-09+YST025+ULW=300	
P601	DE485923162S	CONN WAFER	YW025-03 (STICK)	
P801	DE4859242220	CONN WAFER	YFW800-02	
P802	DE4859242220	CONN WAFER	YFW800-02	
P904	DE4859262120	CONN WAFER	YFW800-01	
PWC1	DE4859903110	CORD POWER AS	CW4232+BL102NG+TUBE=2500	△
Q301	DETKTC3198Y-	TR	KTC3198Y	
Q401	DET2SD2499—	TR	2SD2499	△
Q402	DET2SD1207T-	TR	2SD1207-T (TAPPING)	△
Q501	DETKTC3198Y-	TR	KTC3198Y	
Q502	DETKTC3198Y-	TR	KTC3198Y	
Q503	DETKTC3198Y-	TR	KTC3198Y	
Q504	DETKTA1266Y-	TR	KTA1266Y (TP)	
Q505	DETKTC3198Y-	TR	KTC3198Y	
Q601	DETKTC3198Y-	TR	KTC3198Y	
Q602	DETKTC3198Y-	TR	KTC3198Y	
Q603	DETKTC3198Y-	TR	KTC3198Y	
Q604	DETKTC3198Y-	TR	KTC3198Y	
Q701	DETKTA1266Y-	TR	KTA1266Y (TP)	
Q704	DETKTC3202Y-	TR	KTC3202Y (TP)	
Q705	DETKTC3198Y-	TR	KTC3198Y	
Q706	DETKTC3198Y-	TR	KTC3198Y	
Q707	DETKTC3198Y-	TR	KTC3198Y	
Q708	DETKTA1266Y-	TR	KTA1266Y (TP)	
Q709	DETKTA1266Y-	TR	KTA1266Y (TP)	
Q710	DETKTA1266Y-	TR	KTA1266Y (TP)	
Q711	DETBS170—	FET	BS170	
Q801	DETKTC3198Y-	TR	KTC3198Y	
Q802	DETKTC3198Y-	TR	KTC3198Y	
Q803	DETKTC3198Y-	TR	KTC3198Y	
Q804	DETKTC3198Y-	TR	KTC3198Y	
Q901	DETKTA1266Y-	TR	KTA1266Y (TP)	
R106	DERD-AZ682J-	R CARBON FILM	1/6 6.8K OHM J	
R107	DERD-AZ333J-	R CARBON FILM	1/6 33K OHM J	
R108	DERD-AZ122J-	R CARBON FILM	1/6 1 2K OHM J	

LOC.	PART-CODE	PART-NAME	PART-DESCRIPTION	REMARK
R109	DERD-AZ183J-	R CARBON FILM	1/6 18K OHM J	
R110	DERD-AZ182J-	R CARBON FILM	1/6 1 8K OHM J	
R111	DERD-AZ104J-	R CARBON FILM	1/6 100K OHM J	
R112	DERD-AZ104J-	R CARBON FILM	1/6 100K OHM J	
R301	DERD-AZ393J-	R CARBON FILM	1/6 39K OHM J	
R302	DERD-AZ182J-	R CARBON FILM	1/6 1.8K OHM J	
R304	DERD-4Z189J-	R CARBON FILM	1/4 1.8 OHM J	
R305	DERD-4Z189J-	R CARBON FILM	1/4 1.8 OHM J	
R307	DERS02Z271J-	R M-OXIDE FILM	2W 270 OHM J (TAPPING)	
R308	DERD-AZ472J-	R CARBON FILM	1/6 4.7K OHM J	
R309	DERD-AZ223J-	R CARBON FILM	1/6 22K OHM J	
R310	DERD-4Z473J-	R CARBON FILM	1/4 47K OHM J	
R311	DERD-AZ472J-	R CARBON FILM	1/6 4.7K OHM J	
R312	DERD-AZ479J-	R CARBON FILM	1/6 4 7 OHM J	
R401	DERD-AZ102J-	R CARBON FILM	1/6 1K OHM J	
R402	DERD-AZ303J-	R CARBON FILM	1/6 30K OHM J	
R403	DERD-AZ479J-	R CARBON FILM	1/6 4.7 OHM J	
R404	DERD-AZ152J-	R CARBON FILM	1/6 1.5K OHM J	
R405	DERD-AZ101J-	R CARBON FILM	1/6 100 OHM J	
R406	DERD-AZ272J-	R CARBON FILM	1/6 2 7K OHM J	
R408	DERS02Z561J-	R M-OXIDE FILM	2W 560 OHM J (TAPPING)	
R409	DERD-4Z103J-	R CARBON FILM	1/4 10K OHM J	
R410	DERD-2Z399J-	R CARBON FILM	1/2 3.9 OHM J	
R411	DE85801065GY	WIRE COPPER	AWG22 1/0.65 TIN COATING	
R412	DE85801065GY	WIRE COPPER	AWG22 1/0 65 TIN COATING	
R413	DERD-4Z124J-	R CARBON FILM	1/4 120K OHM J	
R414	DERD-4Z273J-	R CARBON FILM	1/4 27K OHM J	
R415	DERF01Z129JA	R FUSIBLE	1W 1.2 OHM J A CURVE	△
R416	DERD-AZ303J-	R CARBON FILM	1/6 30K OHM J	
R417	DERD-4Z102J-	R CARBON FILM	1/4 1K OHM J	
R418	DERD-AZ124J-	R CARBON FILM	1/6 120K OHM J	
R420	DE85801065GY	WIRE COPPER	AWG22 1/0 65 TIN COATING	
R501	DERD-AZ102J-	R CARBON FILM	1/6 1K OHM J	
R502	DERD-AZ101J-	R CARBON FILM	1/6 100 OHM J	
R503	DERD-AZ101J-	R CARBON FILM	1/6 100 OHM J	
R504	DERD-AZ331J-	R CARBON FILM	1/6 330 OHM J	
R505	DERD-AZ470J-	R CARBON FILM	1/6 47 OHM J	
R506	DERD-AZ101J-	R CARBON FILM	1/6 100 OHM J	
R507	DERD-4Z109J-	R CARBON FILM	1/4 1 OHM J	
R508	DERD-AZ102J-	R CARBON FILM	1/6 1K OHM J	
R509	DERD-AZ121J-	R CARBON FILM	1/6 120 OHM J	
R510	DERD-AZ102J-	R CARBON FILM	1/6 1K OHM J	
R511	DERD-AZ101J-	R CARBON FILM	1/6 100 OHM J	
R512	DERD-AZ101J-	R CARBON FILM	1/6 100 OHM J	
R513	DERD-AZ101J-	R CARBON FILM	1/6 100 OHM J	
R514	DERD-AZ104J-	R CARBON FILM	1/6 100K OHM J	
R515	DERD-AZ102J-	R CARBON FILM	1/6 1K OHM J	
R516	DERD-AZ564J-	R CARBON FILM	1/6 560K OHM J	
R517	DE5CPZ569K02	COIL PEAKING	5 6UH K (AXIAL 3 5MM)	
R518	DERD-AZ103J-	R CARBON FILM	1/6 10K OHM J	
R519	DERD-AZ470J-	R CARBON FILM	1/6 47 OHM J	
R520	DERD-AZ394J-	R CARBON FILM	1/6 390K OHM J	
R521	DERD-AZ513J-	R CARBON FILM	1/6 51K OHM J	

LOC.	PART-CODE	PART-NAME	PART-DESCRIPTION	REMARK
R524	DERD-AZ303J-	R CARBON FILM	1/6 30K OHM J	
R525	DERD-AZ121J-	R CARBON FILM	1/6 120 OHM J	
R526	DERD-4Z100J-	R CARBON FILM	1/4 10 OHM J	
R527	DERD-AZ750J-	R CARBON FILM	1/6 75 OHM J	
R528	DERD-AZ103J-	R CARBON FILM	1/6 10K OHM J	
R529	DERD-AZ103J-	R CARBON FILM	1/6 10K OHM J	
R530	DERD-AZ750J-	R CARBON FILM	1/6 75 OHM J	
R531	DERD-AZ750J-	R CARBON FILM	1/6 75 OHM J	
R532	DERD-AZ750J-	R CARBON FILM	1/6 75 OHM J	
R533	DERD-AZ750J-	R CARBON FILM	1/6 75 OHM J	
R534	DERD-AZ750J-	R CARBON FILM	1/6 75 OHM J	
R535	DERD-AZ102J-	R CARBON FILM	1/6 1K OHM J	
R536	DERD-AZ102J-	R CARBON FILM	1/6 1K OHM J	
R537	DERD-AZ101J-	R CARBON FILM	1/6 100 OHM J	
R538	DERD-AZ101J-	R CARBON FILM	1/6 100 OHM J	
R539	DERD-AZ102J-	R CARBON FILM	1/6 1K OHM J	
R540	DERD-AZ472J-	R CARBON FILM	1/6 4 7K OHM J	
R541	DERD-AZ151J-	R CARBON FILM	1/6 150 OHM J	
R542	DERD-AZ151J-	R CARBON FILM	1/6 150 OHM J	
R543	DERD-AZ151J-	R CARBON FILM	1/6 150 OHM J	
R601	DERD-AZ471J-	R CARBON FILM	1/6 470 OHM J	
R602	DERD-AZ561J-	R CARBON FILM	1/6 560 OHM J	
R603	DERD-AZ681J-	R CARBON FILM	1/6 680 OHM J	
R604	DERD-AZ562J-	R CARBON FILM	1/6 5 6K OHM J	
R605	DERD-AZ270J-	R CARBON FILM	1/6 27 OHM J	
R606	DERD-AZ391J-	R CARBON FILM	1/6 390 OHM J	
R607	DERD-AZ113J-	R CARBON FILM	1/6 11K OHM J	
R608	DERD-AZ102J-	R CARBON FILM	1/6 1K OHM J	
R609	DERD-AZ103J-	R CARBON FILM	1/6 10K OHM J	
R610	DERD-AZ102J-	R CARBON FILM	1/6 1K OHM J	
R611	DE85801065GY	WIRE COPPER	AWG22 1/0.65 TIN COATING	
R612	DERD-AZ153J-	R CARBON FILM	1/6 15K OHM J	
R613	DERD-AZ153J-	R CARBON FILM	1/6 15K OHM J	
R614	DERD-AZ473J-	R CARBON FILM	1/6 47K OHM J	
R615	DERD-AZ102J-	R CARBON FILM	1/6 1K OHM J	
R616	DERD-4Z221J-	R CARBON FILM	1/4 220 OHM J	
R617	DERD-AZ682J-	R CARBON FILM	1/6 6.8K OHM J	
R618	DERD-AZ222J-	R CARBON FILM	1/6 2.2K OHM J	
R619	DERD-AZ471J-	R CARBON FILM	1/6 470 OHM J	
R620	DERD-AZ221J-	R CARBON FILM	1/6 220 OHM J	
R621	DERD-AZ102J-	R CARBON FILM	1/6 1K OHM J	
R622	DERD-AZ102J-	R CARBON FILM	1/6 1K OHM J	
R623	DERD-4Z221J-	R CARBON FILM	1/4 220 OHM J	
R624	DERD-AZ303J-	R CARBON FILM	1/6 30K OHM J	
R639	DERD-AZ222J-	R CARBON FILM	1/6 2.2K OHM J	
R701	DERD-AZ102J-	R CARBON FILM	1/6 1K OHM J	
R702	DERD-AZ332J-	R CARBON FILM	1/6 3 3K OHM J	
R703	DERD-AZ332J-	R CARBON FILM	1/6 3 3K OHM J	
R704	DERD-AZ101J-	R CARBON FILM	1/6 100 OHM J	
R705	DERD-AZ101J-	R CARBON FILM	1/6 100 OHM J	
R706	DERD-AZ103J-	R CARBON FILM	1/6 10K OHM J	
R707	DERD-AZ103J-	R CARBON FILM	1/6 10K OHM J	
R708	DERD-AZ103J-	R CARBON FILM	1/6 10K OHM J	

LOC.	PART-CODE	PART-NAME	PART-DESCRIPTION	REMARK
R709	DERD-AZ103J-	R CARBON FILM	1/6 10K OHM J	
R710	DERD-AZ100J-	R CARBON FILM	1/6 10 OHM J	
R711	DERD-AZ333J-	R CARBON FILM	1/6 33K OHM J	
R714	DE85801065GY	WIRE COPPER	AWG22 1/0.65 TIN COATING	
R715	DERD-AZ912J-	R CARBON FILM	1/6 9 1K OHM J	
R716	DERD-AZ823J-	R CARBON FILM	1/6 82K OHM J	
R717	DERD-AZ472J-	R CARBON FILM	1/6 4.7K OHM J	
R718	DERD-AZ472J-	R CARBON FILM	1/6 4.7K OHM J	
R719	DERD-4Z103J-	R CARBON FILM	1/4 10K OHM J	
R720	DERS02Z562J-	R M-OXIDE FILM	2W 5.6K OHM J (TAPPING)	
R721	DERD-AZ682J-	R CARBON FILM	1/6 6.8K OHM J	
R722	DERD-AZ822J-	R CARBON FILM	1/6 8.2K OHM J	
R723	DERD-AZ682J-	R CARBON FILM	1/6 6 8K OHM J	
R724	DE85801065GY	WIRE COPPER	AWG22 1/0 65 TIN COATING	
R725	DERD-AZ913J-	R CARBON FILM	1/6 91K OHM J	
R727	DERD-AZ103J-	R CARBON FILM	1/6 10K OHM J	
R728	DERD-4Z100J-	R CARBON FILM	1/4 10 OHM J	
R729	DERD-AZ333J-	R CARBON FILM	1/6 33K OHM J	
R730	DERD-AZ333J-	R CARBON FILM	1/6 33K OHM J	
R731	DERD-AZ333J-	R CARBON FILM	1/6 33K OHM J	
R732	DERD-AZ472J-	R CARBON FILM	1/6 4.7K OHM J	
R733	DERD-AZ472J-	R CARBON FILM	1/6 4 7K OHM J	
R734	DERD-AZ472J-	R CARBON FILM	1/6 4.7K OHM J	
R735	DERD-AZ472J-	R CARBON FILM	1/6 4.7K OHM J	
R736	DERD-AZ472J-	R CARBON FILM	1/6 4 7K OHM J	
R737	DERD-AZ472J-	R CARBON FILM	1/6 4.7K OHM J	
R738	DERD-AZ122J-	R CARBON FILM	1/6 1.2K OHM J	
R739	DERD-AZ122J-	R CARBON FILM	1/6 1.2K OHM J	
R740	DERD-AZ122J-	R CARBON FILM	1/6 1.2K OHM J	
R741	DERD-AZ102J-	R CARBON FILM	1/6 1K OHM J	
R743	DERD-AZ101J-	R CARBON FILM	1/6 100 OHM J	
R744	DERD-AZ101J-	R CARBON FILM	1/6 100 OHM J	
R745	DERD-AZ103J-	R CARBON FILM	1/6 10K OHM J	
R746	DERD-AZ272J-	R CARBON FILM	1/6 2.7K OHM J	
R748	DERD-AZ622J-	R CARBON FILM	1/6 6 2K OHM J	
R749	DERD-AZ472J-	R CARBON FILM	1/6 4.7K OHM J	
R750	DERD-AZ101J-	R CARBON FILM	1/6 100 OHM J	
R751	DERD-AZ473J-	R CARBON FILM	1/6 47K OHM J	
R753	DERD-AZ202J-	R CARBON FILM	1/6 2K OHM J	
R754	DERS02Z562J-	R M-OXIDE FILM	2W 5 6K OHM J (TAPPING)	
R755	DERD-AZ109J-	R CARBON FILM	1/6 1 OHM J	
R756	DERD-AZ472J-	R CARBON FILM	1/6 4.7K OHM J	
R757	DERD-AZ473J-	R CARBON FILM	1/6 47K OHM J	
R759	DERD-AZ391J-	R CARBON FILM	1/6 390 OHM J	
R760	DERD-AZ472J-	R CARBON FILM	1/6 4.7K OHM J	
R761	DERD-AZ472J-	R CARBON FILM	1/6 4.7K OHM J	
R762	DERD-AZ102J-	R CARBON FILM	1/6 1K OHM J	
R801	DEDEC180M290	POSISTOR	ECPC180M290	△
R802	DERX10B339JN	R CEMENT	10W 3.3 OHM J BENCH 4P	△
R803	DERS02Z683J-	R M-OXIDE FILM	2W 68K OHM J (TAPPING)	
R804	DERF02Z568J-	R FUSIBLE	2W 0 56 OHM J (TAPPING)	△
R805	DERS01Z240J-	R M-OXIDE FILM	1W 24 OHM J (TAPPING)	
R806	DERN01B101JS	R METAL FILM	1W 100 OHM J SMALL	

LOC.	PART-CODE	PART-NAME	PART-DESCRIPTION	REMARK
R807	DERS01Z242J-	R M-OXIDE FILM	1W 2.4K OHM J (TAPPING)	
R808	DERD-4Z104J-	R CARBON FILM	1/4 100K OHM J	
R809	DERD-4Z222J-	R CARBON FILM	1/4 2.2K OHM J	
R810	DERD-4Z220J-	R CARBON FILM	1/4 22 OHM J	
R811	DERD-4Z102J-	R CARBON FILM	1/4 1K OHM J	
R812	DERC-2Z565J-	R CARBON COMP	1/2 5 6M OHM J	
R813	DERD-AZ473J-	R CARBON FILM	1/6 47K OHM J	
R814	DERD-4Z242J-	R CARBON FILM	1/4 2.4K OHM J	
R815	DERD-2Z104J-	R CARBON FILM	1/2 100K OHM J	
R816	DERD-2Z104J-	R CARBON FILM	1/2 100K OHM J	
R817	DERD-4Z102J-	R CARBON FILM	1/6 1K OHM J	
R818	DERD-AZ472J-	R CARBON FILM	1/6 4.7K OHM J	
R819	DERS02Z620J-	R M-OXIDE FILM	2W 62 OHM J (TAPPING)	
R820	DERD-AZ103J-	R CARBON FILM	1/6 10K OHM J	
R901	DERD-AZ302J-	R CARBON FILM	1/6 3K OHM J	
R902	DERD-AZ302J-	R CARBON FILM	1/6 3K OHM J	
R903	DERD-AZ302J-	R CARBON FILM	1/6 3K OHM J	
R904	DERD-AZ202J-	R CARBON FILM	1/6 2K OHM J	
R905	DERD-AZ202J-	R CARBON FILM	1/6 2K OHM J	
R906	DERD-AZ202J-	R CARBON FILM	1/6 2K OHM J	
R907	DERD-4Z104J-	R CARBON FILM	1/4 100K OHM J	
R908	DERD-4Z104J-	R CARBON FILM	1/4 100K OHM J	
R909	DERD-4Z104J-	R CARBON FILM	1/4 100K OHM J	
R911	DERC-2Z152J-	R CARBON COMP	1/2 1.5K OHM J	
R912	DERC-2Z152J-	R CARBON COMP	1/2 1.5K OHM J	
R913	DERC-2Z152J-	R CARBON COMP	1/2 1.5K OHM J	
R914	DERD-AZ103J-	R CARBON FILM	1/6 10K OHM J	
R920	DE85801065GY	WIRE COPPER	AWG22 1/0.65 TIN COATING	
SCT1	DE4859303030	SOCKET CRT	ISMM03S	△
SF101	DE5PG1966M—	FILTER SAW	G1966M	
SW701	DE5S50101090	SW TACT	SKHV17910A	
SW702	DE5S50101090	SW TACT	SKHV17910A	
SW703	DE5S50101090	SW TACT	SKHV17910A	
SW704	DE5S50101090	SW TACT	SKHV17910A	
SW705	DE5S50101090	SW TACT	SKHV17910A	
SW801	DE5S40101143	SW PUSH	PS3-22SP (P.C.B)	△
T401	DE50D10A2—	TRANS DRIVE	TD-10A2	△
T402	DE50H0000177	FBT	HST1142.5057	△
T801	DE50M3934A1-	TRANS SMPS	TSM-3934A1	△
U101	DE4859714430	TUNER VARACTOR	3303KHC-3X1289	
X501	DE5XE4R4336E	CRYSTAL QUARTZ	HC-49/U 4.433619MHZ 30PPM	
X701	DE5XE18R000E	CRYSTAL QUARTZ	HC-49/U 18.000MHZ 30PPM	
Z501	DE5PXPS5R5MB	FILTER CERA	TPS5 5MB-TF21 (TP)	
Z601	DE5PXF5H5R5M	FILTER CERA	SFSH5.5MCB-TF21 (TP)	
*	DE48B1530SVC	SERVICE REMOCON	R-30SVC	

Difference of Parts for CRT

NO.	LOC.	NAME	14" Orion	14" Thomson	14" Philips	20" Orion	20" Thomson	21" Thomson	21" Philips
1	V901	CRT BARE	A34JLL90X01 4859605142	A34EFU13X01 4859606640	A34EAC01X06 4859606240	A48JLL90X02 4859604162	A48EEV33X01 4859611260	A51EBV13X09 4859621760	A51EAL55X01 4859607660
2	SCT1	SOCKET CRT	ISMM03S 4859303030	--	ISMM03S 4859303030	ISMM03S 4859303030	--	--	--
3	SCT2	SOCKET CRT	--	ISHS09S 4859302930	--	--	ISHS09S 4859302930	ISHS09S 4859302930	ISHS09S 4859302930
4	LP03	COIL BEAD	MD-5 5MC0000100	--	--	MD-5 5MC0000100	--	MD-5 5MC0000100	MD-5 5MC0000100
5	LP04	COIL BEAD	--	MD-5 5MC0000100	MD-5 5MC0000100	--	MD-5 5MC0000100	--	--
6	L405	COIL H-LIN.	L-125 58H0000018	L-102 58H0000016	L-102 58H0000016	L-102 58H0000016	L-76 58H0000020	L-125 58H0000018	L-102 58H0000016
7	C410	C MYLAR	1.6KV 7500 CMYH3C752J	1.6KV 6200 CMYH3C622J	1.6KV 6200 CMYH3C622J	1.6KV 7500 CMYH3C752J	1.6KV 7200 CMYH3C722J	1.6KV 6900 CMYH3C692J	1.6KV 7500 CMYH3C752J
8	C409	C CERA	2KV 470 CCXB3D471K	2KV 470 CCXB3D471K	2KV 470 CCXB3D471K	2KV 470 CCXB3D471K	2KV 220 CCXB3D221K	2KV 470 CCXB3D471K	2KV 470 CCXB3D471K
9	C411	C MYLAR	200V 0.47 CMYE2D474J	250V 0.68 J CMYT2E684J	200V 0.51 CMYE2D514J	200V 0.36 CMYE2D364J	200V 0.39 CMYE2D394J	200V 0.51 CMYE2D514J	200V 0.51 CMYE2D514J
10	R413	R C-FILM	1/4W 120K RD-4Z124J-	1/4W 150K RD-4Z154J	1/4W 150K RD-4Z154J	1/4W 68K RD-4Z683J	1/4W 82K RD-4Z823J	1/4W 68K RD-4Z683J	1/4W 68K RD-4Z683J
11	R415	R FUSIBLE	1W 1.2 A (F) RF01Z129JA	1W 0.18 (F) RF01Z188J-	1W 0.47 (F) RF01Z478J-	1W 2.4 A (F) RF01Z249JA	1W 0.47 (F) RF01Z478J-	1W 1.2 A (F) RF01Z129JA	1W 3 A (F) RF01Z309JA
12	R302	R C-FILM	1/6W 1.8K RD-AZ182J-	1/6W 2.2K RD-AZ222J	1/6W 1.8K RD-AZ182J-	1/6W 2.2K RD-AZ222J	1/6W 2.2K RD-AZ222J	1/6W 2.2K RD-AZ222J	1/6W 2.7K RD-AZ272J
13	R901-3	R C-FILM	1/6W 3K RD-AZ302J-	1/6W 2.4K RD-AZ242J-	1/6W 2.4K RD-AZ242J-	1/6W 2K RD-AZ202J-	1/6W 2K RD-AZ202J-	1/6W 2K RD-AZ202J-	1/6W 2K RD-AZ202J-
14	R904-6	R C-FILM	1/6W 2K RD-AZ202J-	1/6W 2K RD-AZ202J-	1/6W 2K RD-AZ202J-	1/6W 1.6K RD-AZ162J-	1/6W 1.6K RD-AZ162J-	1/6W 1.6K RD-AZ162J-	1/6W 1.6K RD-AZ162J-
15	R807	R C-FILM	1W 2.4K RS01Z242J-	1W 2.4K RS01Z242J-	1W 2.4K RS01Z242J-	1W 2.7K RS01Z272J-	1W 2.7K RS01Z272J-	1W 2.7K RS01Z272J-	1W 2.7K RS01Z272J-
16	P401	CONN WAFER	YFW500-05 4859240020	YFW500-06 4859240120	YFW500-06 4859240120	YFW500-05 4859240020	YFW500-06 4859240120	YFW500-06 4859240120	YFW500-06 4859240120
17	P401A	CONN AS	--	35135/0620 +35179 +ULW=350 4850706S20	35135/0620 +35179 +ULW=350 4850706S20	--	ODY-2109 4850706057	ODY-2109 4850706057	ODY-2109 4850706057
18	ZZ131	COIL DEGAUSS	DC1450 58G0000084	DC1450 58G0000084	DC1450 58G0000084	DC2050 58G0000086	DC2050 58G0000086	DC2070 58G0000074	DC2070 58G0000074
20	ZZ132	CRT GND AS	1401H-1015-1P 48519A4610	1401H-1015-1P 48519A4610	1401H-1015-1P 48519A4610	2001H-1015-1P 48519A5010	2001H-1015-1P 48519A5010	2101H-1015-1P 48519A5210	2101H-1015-1P 48519A5210



Difference of Parts for System

NO.	LOC.	NAME	PAL-B/G	PAL-I	P/SECAM-L
1	PWC1	POWER CORD AS	CW4232 DE4859903110	CW3222 DE4859905110	CW4232 DE4859903110
2	SF101	SAW FILTER	G1966M DE5PG1966M--	J1952M DE5PJ1952M-	G1966M DE5PG1966M--
3	Z501	CERA FILTER	TPS5 5MB-TF21 DE5PXPS5R5MB	TPS6 0MB DE5PTPS60MB-	TPS5.5MB-TF21 DE5PXPS5R5MB
4	Z601	CERA. FILTER	SFSH5.5MCB-TF21 DE5PXF5H5R5M	SFSH6 0MCB-TF21 DE5PXF5H6R0M	SFSH5 5MCB-TF21 DE5PXF5H5R5M
5	I503	IC SECAM	-	-	TDA8395 DE1TDA8395--
6	Q705-706	TR	KTC3198Y DETKTC3198Y-	-	KTC3198Y DETKTC3198Y-
7	Q708-709	TR	KTA1266Y- DETKTA1266Y-	-	KTA1266Y DETKTA1266Y-
8	R729-730	R C-FILM	1/6W 33K DERD-AZ333J-	-	1/6W 33K DERD-AZ333J-
9	R732-733	R C-FILM	1/6W 4 7K DERD-AZ472J-	-	1/6W 4 7K DERD-AZ472J-
10	R736-737	R C-FILM	1/6W 4 7K DERD-AZ472J-	-	1/6W 4 7K DERD-AZ472J-
11	C105,107	C ELECTRO	50V 4.7μ DECEXF1H479V	-	50V 4 7μ DECEXF1H479V
12	C106, 108	C CERA	50V 0 01μ DECCZF1E103Z	-	50V 0 01μ DECCZF1E103Z
13	U101	TUNER	3303KHC DE4859714430	DT2-IV17D DE4859716130	3303KHC DE4859714430
14	Z101-102	CERA, FILTER	-	-	MKT40MA100P DE5PMKT40MA-
15	IL01	IC AM DEMOD.	-	-	STV8225 DE1STV8225--
16	SL01	SAW FILTER	-	-	L9461M DE5PL9461M--
17	QL01	TR	-	-	KTC3198Y DEDTKTC3198Y
18	QL02	TR	-	-	KTC3198Y DEDTKTC3198Y
19	QL03	TR	-	-	KTC3197 DETKTC3197--
20	Q702	TR	-	-	KTC3198Y DEDTKTC3198Y
21	DL01-02	DIODE	-	-	1S2186 DED1S2186---
22	RL01	R C-FILTER	-	-	1/6W 22K DERD-AZ223J-
23	RL02	R C-FILTER	-	-	1/6W 100 DERD-AZ101J-
24	RL03	R C-FILTER	-	-	1/6W 2 2K DERD-AZ222J-
25	RL04	R C-FILTER	-	-	1/6W 10K DERD-AZ103J-
26	RL05	R C-FILTER	-	-	1/6W 10K DERD-AZ103J-
27	RL06	R C-FILTER	-	-	1/6W 68K DERD-AZ683J-
28	RL07	R C-FILTER	-	-	1/4W 120 DERD-4Z121J-
29	RL08	R C-FILTER	-	-	1/6W 15K DERD-AZ153J-
30	RL09	R C-FILTER	-	-	1/6W 750 DERD-AZ751J-

Difference of Parts for System

NO	LOC	NAME	PAL-B/G	PAL-I	P/SECAM-L
31	RL01	R C-FILM	-	-	1/6W 2 2K DERD-AZ222J-
32	R101	R C-FILM	-	-	1/6W 47 DERD-AZ470J-
33	R712	R C-FILM	-	-	1/6W 10K DERD-AZ103J-
34	R713	R C-FILM	-	-	1/6W 6 8K DERD-AZ682J-
35	R752	R C-FILM	-	-	1/6W 10K DERD-AZ103J-
36	R763	R C-FILM	-	-	1/6W 100 DERD-4Z101J-
37	CL07	C CERA	-	-	50V 82 DECCZB1H820K
38	CL01	C CERA	-	-	50V CH 22 DECZCH1H220J
39	CL02	C ELECTRO	-	-	50V 47μ DECEXF1H470V
40	CL03	C CERA	-	-	50V 0.01μ DECCZF1E103Z
41	CL04	C ELECTRO	-	-	50V 4 7μ DECEXF1H479V
42	CL05	C CERA	-	-	50V CH 22 DECZCH1H220J
43	CL06	C ELECTRO	-	-	50V 4 7μ DECEXF1H479V
44	C707	C ELECTRO	-	-	50V 10μ DECEXF1H100V
45	C728	C CERA	-	-	25V 0 022μF DECCZF1E223Z
46	JP08-09	WIRE COPPER	WIRE COPPER DE85801065GY	WIRE COPPER DE85801065GY	-
47	I501	TDA8374A	TDA8374A DE1TDA8374A-	TDA8374A DE1TDA8374A-	TDA8374A DE1TDA8374A--
48	C104	C ELECTRO	50V 4.7μ DECEXF1H479V	50V 4 7μ DECEXF1H479V	50V 33μ DECEXF1H330V

Difference of parts for Option

-Teletext option

OPTION	I701 (IC MICOM)	X701 (X-TAL)	C719 (C MYLAR)
West Europe Teletext	DW5255M* DE1DW5255M*-	HC-49U 18MHz DE5XE18R000E	50V EU 0 33μF DECMXB1H334J
Non-Teletext	DW370M* DE1DW370M*-	HC-49U 20MHz DE5XE20R000E	- -

-Antenna option

MODEL	NAME	REMARK
PAL-B/G, P/SECAM-L	PH-RM-003 DE4850A02910	Rod Antenna
PAL-I	PH-RM-006 DE4850A01220	Loop Antenna

MECHANICAL EXPLODED VIEWS AND PART LIST

1421

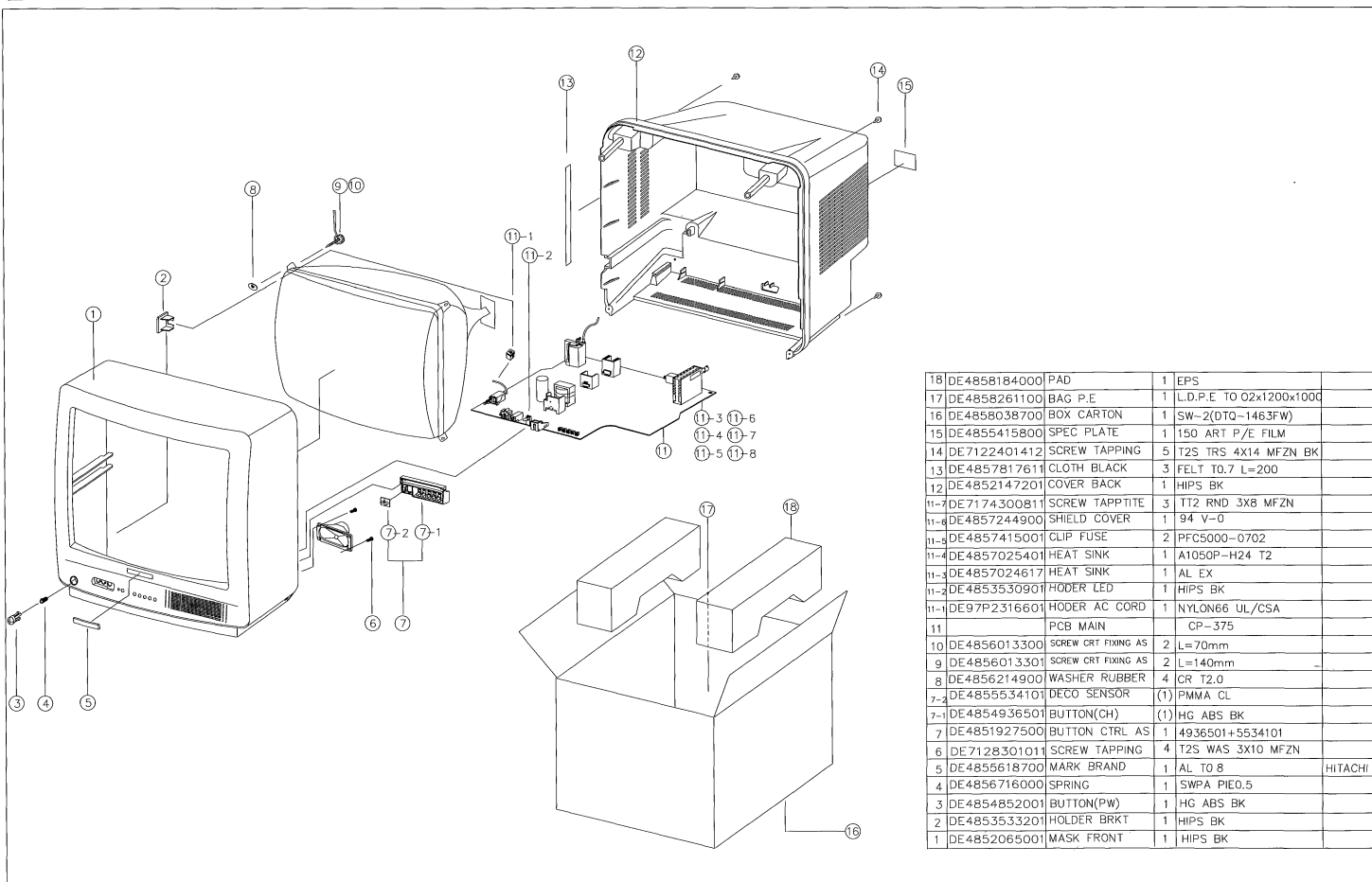

18	DE4858184000	PAD	1	EPS	
17	DE4858261100	BAG P.E	1	L.D.P.E TO O2x1200x1000	
16	DE4858038700	BOX CARTON	1	SW-2(DTQ-1463FW)	
15	DE4855415800	SPEC PLATE	1	150 ART P/E FILM	
14	DE7122401412	SCREW TAPPING	5	T2S TRS 4X14 MFZN BK	
13	DE4857817611	CLOTH BLACK	3	FELT T0.7 L=200	
12	DE4852147201	COVER BACK	1	HIPS BK	
11-7	DE7174300811	SCREW TAPP TITE	3	TT2 RND 3X8 MFZN	
11-6	DE4857244900	SHIELD COVER	1	94 V-0	
11-5	DE4857415001	CLIP FUSE	2	PFC5000-0702	
11-4	DE4857025401	HEAT SINK	1	A1050P-H24 T2	
11-3	DE4857024617	HEAT SINK	1	AL EX	
11-2	DE4853530901	HOODER LED	1	HIPS BK	
11-1	DE97P2316601	HOODER AC CORD	1	NYLON66 UL/CSA	
11		PCB MAIN		CP-375	
10	DE4856013300	SCREW CRT FIXING AS	2	L=70mm	
9	DE4856013301	SCREW CRT FIXING AS	2	L=140mm	
8	DE4856214900	WASHER RUBBER	4	CR T2.0	
7-2	DE4855534101	DECO SENSOR	(1)	PMMA CL	
7-1	DE4854936501	BUTTON(CH)	(1)	HG ABS BK	
7	DE4851927500	BUTTON CTRL AS	1	4936501+5534101	
6	DE7128301011	SCREW TAPPING	4	T2S WAS 3X10 MFZN	
5	DE4855618700	MARK BRAND	1	AL TO 8	HITACHI
4	DE4856716000	SPRING	1	SWPA PIE0.5	
3	DE4854852001	BUTTON(PW)	1	HG ABS BK	
2	DE4853533201	HOLDER BRKT	1	HIPS BK	
1	DE4852065001	MASK FRONT	1	HIPS BK	

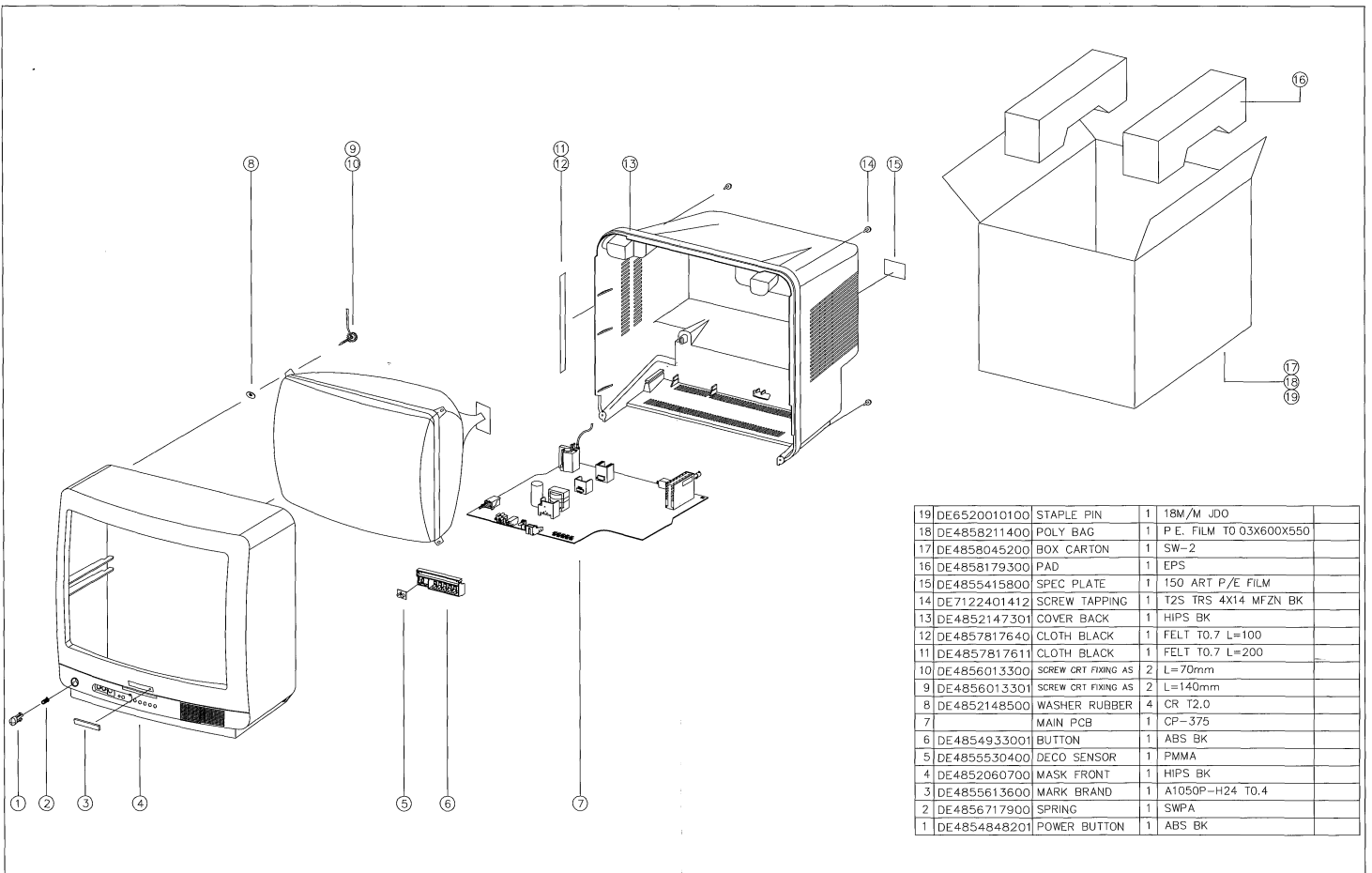

19	DE6520010100	STAPLE PIN	1	18M/M JDO	
18	DE4858211400	POLY BAG	1	P. E. FILM TO 03X600X550	
17	DE4858045200	BOX CARTON	1	SW-2	
16	DE4858179300	PAD	1	EPS	
15	DE4855415800	SPEC PLATE	1	150 ART P/E FILM	
14	DE7122401412	SCREW TAPPING	1	T25 TRS 4X14 MFZN BK	
13	DE4852147301	COVER BACK	1	HIPS BK	
12	DE4857817640	CLOTH BLACK	1	FELT T0.7 L=100	
11	DE4857817611	CLOTH BLACK	1	FELT T0.7 L=200	
10	DE4856013300	SCREW CRT FIXING AS	2	L=70mm	
9	DE4856013301	SCREW CRT FIXING AS	2	L=140mm	
8	DE4852148500	WASHER RUBBER	4	CR T2.0	
7		MAIN PCB	1	CP-375	
6	DE4854933001	BUTTON	1	ABS BK	
5	DE4855530400	DECO SENSOR	1	PMMA	
4	DE4852060700	MASK FRONT	1	HIPS BK	
3	DE4855613600	MARK BRAND	1	A1050P-H24 T0.4	
2	DE4856717900	SPRING	1	SWPA	
1	DE4854848201	POWER BUTTON	1	ABS BK	

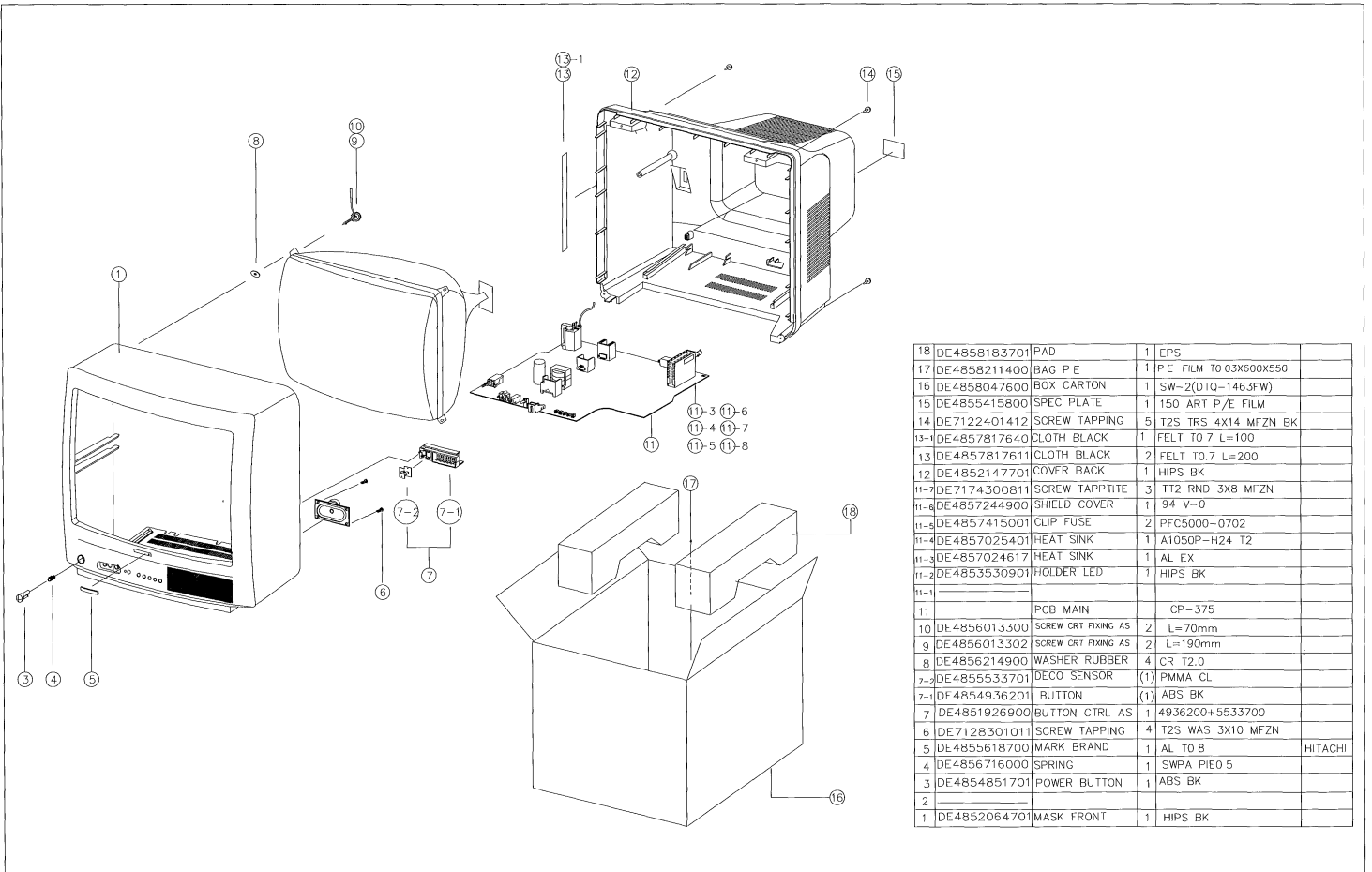

18	DE4858183701	PAD	1	EPS	
17	DE4858211400	BAG P E	1	P E FILM TO 03X600X550	
16	DE4858047600	BOX CARTON	1	SW-2(OTQ-1463FW)	
15	DE4855415800	SPEC PLATE	1	150 ART P/E FILM	
14	DE7122401412	SCREW TAPPING	5	T2S TRS 4X14 MFZN BK	
13-1	DE4857817640	CLOTH BLACK	1	FELT TO 7 L=100	
13	DE4857817611	CLOTH BLACK	2	FELT TO.7 L=200	
12	DE4852147701	COVER BACK	1	HIPS BK	
11-7	DE7174300811	SCREW TAPP TITE	3	TT2 RND 3X8 MFZN	
11-6	DE4857244900	SHIELD COVER	1	94 V-0	
11-5	DE4857415001	CLIP FUSE	2	PFC5000-0702	
11-4	DE4857025401	HEAT SINK	1	A1050P-H24 T2	
11-3	DE4857024617	HEAT SINK	1	AL EX	
11-2	DE4853530901	HOLDER LED	1	HIPS BK	
11-1					
11		PCB MAIN		CP-375	
10	DE4856013300	SCREW CRT FIXING AS	2	L=70mm	
9	DE4856013302	SCREW CRT FIXING AS	2	L=190mm	
8	DE4856214900	WASHER RUBBER	4	CR T2.0	
7-2	DE4855533701	DECO SENSOR	(1)	PMMA CL	
7-1	DE4854936201	BUTTON	(1)	ABS BK	
7	DE4851926900	BUTTON CTRL AS	1	4936200+5533700	
6	DE7128301011	SCREW TAPPING	4	T2S WAS 3X10 MFZN	
5	DE4856187000	MARK BRAND	1	AL TO 8	HITACHI
4	DE4856716000	SPRING	1	SWPA PIE0.5	
3	DE4854851701	POWER BUTTON	1	ABS BK	
2					
1	DE4852064701	MASK FRONT	1	HIPS BK	

HITACHI

HITACHI LTD. TOKYO JAPAN
International Sales Division,
THE HITACHI ATAGO BLDG.
No. 15 -12 Nishi-Shinbashi, 2 - Chome,
Minato-Ku, Tokyo 105, Japan
Tel. Tokyo 3 32581111

HITACHI SALES EUROPA GmbH
Am Seestern 18,
40547 Düsseldorf,
Germany
Tel. 0211 5291 50

HITACHI SALES (HELLAS) S.A.
91, Falirou Street, 117-41 Athens,
Greece
Tel. 92 42-620-4

HITACHI HOME ELECTRONICS (EUROPE) Ltd.
Hitachi House, Station Road, Hayes,
Middlesex UB3 4DR,
England
Tel. 0181 849 2000

HITACHI SALES IBERICA, S.A.
Gran Via Carlos Tercero.101,1 -1
Barcelona 08028
Tel. 3- 330.86.52

HITACHI FRANCE (RADIO-T.V.-ELECTRO-MENAGER) S.A.
4, allée des Sorbiers,
Parc d'active de Chêne,
69671 BRON Cedex,
France
Tel. 72 14-29-70

HITACHI HOME ELECTRONICS NORDIC
Domnarvsgatan 29 Lunda, Box 62
S-163 91 Spanga,
Sweden
Tel. 08 621 8250

**Scan & PDF-Design: Schaltungsdienst
Lange oHG
Verlag technische Druckschriften**

**Zehrendorfer Straße 11
D-12277 Berlin**

<http://www.schaltungsdienst.com>