

SERVICE MANUAL

MINI B/W TELEVISION
WITH AM/FM RADIO &
DIGITAL ALARM CLOCK



SANYO

TPM 2170

(KUW)

CAR CORD - N.L.A.

BATTERY PACK - ~~N.L.A.~~



AC ADAPT. - 1110 9131 16800

MAG. LENS - MLH 2500B









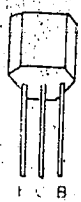

SPECIFICATIONS BATTERY LID - N.L.A.

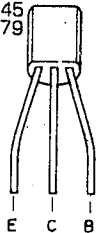
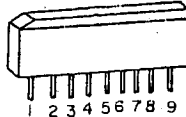
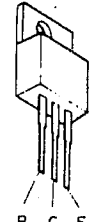
Television System	"I" "G" "B" type, 625 lines/frame, 25 frames/sec., 50 fields/sec.
Frequency Range	"M" type, 525 lines/frame, 30 frames/sec., 60 fields/sec.
Antenna Input Impedance	VHF Channels 2 - 12(EUR-system)
	2 - 13(US-system)
Intermediate Frequency	UHF Channels 21 - 69(UK, EUR-system)
	14 - 83(US-system)
Picture Tube	AM 530 - 1,605 KHz
	FM 87.5 - 108 MHz
Semiconductors	75 ohm
	TV: Picture 38.9 MHz
Loudspeaker	Sound 32.9 MHz(UK)/33.4 MHz(EUR)/34.4 MHz(US)
	Radio: AM 460 KHz
Sound output	FM 10.7 MHz
	2-inch diagonal, 40 degrees deflection, C205P4 or E2225
Power Source	IC 5
	Transistor 45
Power Consumption	Diode 66
	45mm round type, 16 ohm
Dimensions	150mW (10% distortion) 200mW Max
	DC 9V (AC adaptor 110-120/220-240V 50/60Hz)
Weight	Rechargeable battery pack (option)
	DC adaptor (option)/5 "AA" cells (option)
	DC 2.5W
	131mm (W) x 51mm (H) x 157mm (D) approx. (without handle)
	0.8Kg approx.

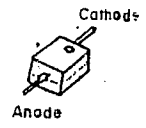
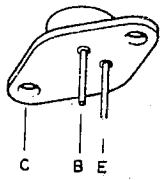
NOTE: Specifications are subject to change without notice.

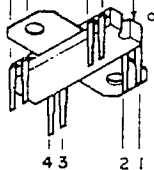
WM4413

TERMINAL VIEW

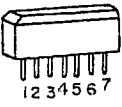
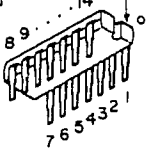
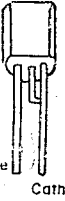
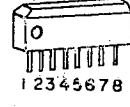
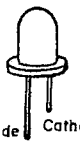
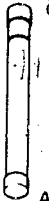
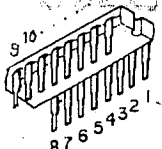
<p>2SC668</p>  <p>E C B</p>	<p>2SD612 2SD826</p>  <p>E C B</p>	<p>TO-92</p> <p>2SA608 2SD545 2SA1048 2SD879 2SB598 2SC2210 2SC2236 2SC2264 2SC2057 2SC2458 2SC2668 2SC2667 2SC536 2SC945 2SC930</p>  <p>E C B</p>	<p>LA3210 TA7137P LA4140</p>  <p>1 2 3 4 5 6 7 8 9</p>	<p>TO-220AB</p> <p>2SB511 2SC1507 2SC1520 2SC1755 2SC1756 2SD313 2SD325 2SD386 2SB507</p>  <p>B C E</p>
<p>2SC983 2SC1941</p>  <p>E C B</p>	<p>MA56</p>  <p>Anode Cathode</p>	<p>TO-3 & 66</p> <p>2SB375 2SC1295 2SC1046 2SC1050 2SD575</p>  <p>C B E</p>	<p>2SC2057</p>  <p>B E C</p>	<p>LA4030P</p>  <p>5 6 7 8 4 3 2 1 Mark</p>
<p>HFSD 1C/HF 1C</p>  <p>Anode Cathode</p>	<p>1JZ61 1R5TH61 ERC27-13 W09C W03A</p>  <p>Anode Cathode</p>	<p>IS553 IS188 IS1834 IS2076 BZ-110 ERB24-02D ERB24-04D ERB24-06D RD7.5E RD11F SIB01-02 SM-1-02FR WZ-075 WZ-063</p> <p>RDS.IEB</p>  <p>Anode Cathode</p>	<p>TA7140P</p>  <p>1 2 3 4 5 6 7</p>	<p>LA3301-HA11229 CA3065 TC4081BP LA1363 LA1365 SN76666 LA1201</p>  <p>8 9 10 11 12 13 14 7 6 5 4 3 2 1 Mark</p>
<p>μPC574J L5630 SVC303 SVC201</p>  <p>Anode Cathode</p>	<p>LA3160</p>  <p>1 2 3 4 5 6 7 8</p>	<p>SLP-131B</p>  <p>Anode Cathode</p>	<p>EDMF 15B EDMF 20B EDMF 25B RF03E14</p>  <p>Anode Cathode</p>	<p>μPC1018C</p>  <p>9 10 11 12 13 14 8 7 6 5 4 3 2 1</p>

E : Emitter C : Collector B : Base S : Shield

CONTROLS AND TERMINAL IDENTIFICATION

1 Light button (LIGHT)

Push this switch to illuminate the LCD clock display.

2 Mode Select button (MODE SELECT)

See Owner's Manual page 5.

3 Aerial

Use this aerial to receive TV (VHF, UHF) and FM radio broadcast.

4 Time Advance button (TIME ADVANCE)

See Owner's Manual page 5.

5 Time Set switch (TIME SET)

See Owner's Manual page 5.

6 Timer Select switch (TIMER SELECT)

Set the selector to wake up with Buzzer, Radio or TV.

7 External Aerial jack (EXT ANT)

Connect the Aerial Adaptor (optional) to this jack to use an external aerial.

8 Earphone jack (EAR)

For private listening, plug the earphone (supplied) into the jack.

9 TV Select switch (TV SELECT)

Set this switch to desired channel band.

10 TV-Radio Select switch (TV-RADIO SELECT)

Select your desired function, TV or Radio (AM or FM).

11 Volume control (VOLUME)

Adjust to obtain your required output volume.

12 Tuning knob

Use to tune to your desired channel or station and obtain vivid picture and clear sound.

13 Main switch

Turns the power ON or OFF or to Timer function. When recharging the rechargeable battery pack (supplied), plug in the AC Adaptor packed with the set and turn this switch to OFF(charge) or TIMER position.

14 TV System switch (TV SYSTEM)

Set this switch to desired television system.

15 Contrast control (CONTRAST)

Adjust this control to obtain proper balance between black and white elements of the picture.

16 Brightness control (BRIGHT)

Adjust this control to obtain desired brilliance of the picture.

Vertical Hold control (V-HOLD)

Adjust this control to stop up or down movement of the picture.

18 Battery Compartment

Remove the lid by pushing to the direction of arrow and install dry cells or rechargeable battery pack.

19 External Power jack (DC IN 9V)

To use the set on AC 110-120/220-240-volt or external DC 12-volt, plug the AC Adaptor or Car Battery Cord Model MDC-53B (optional) into this jack.

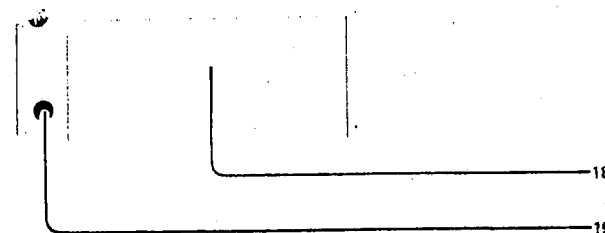
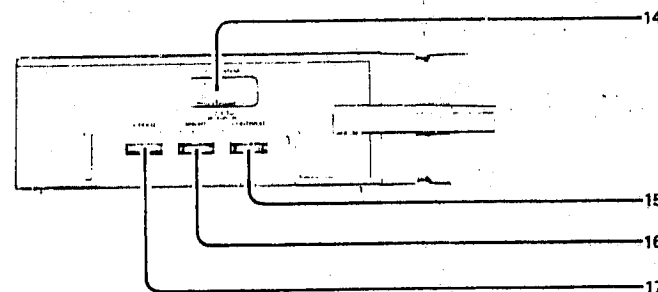
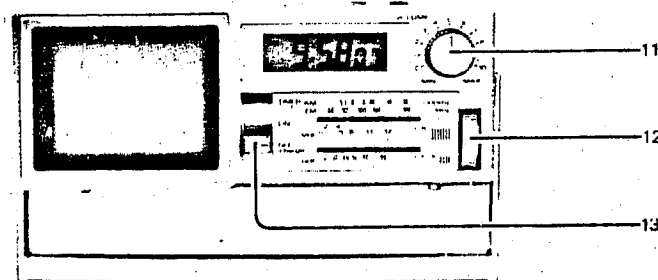
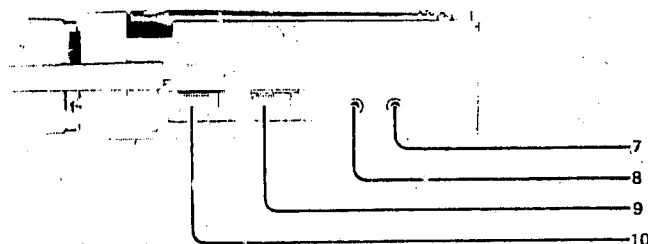
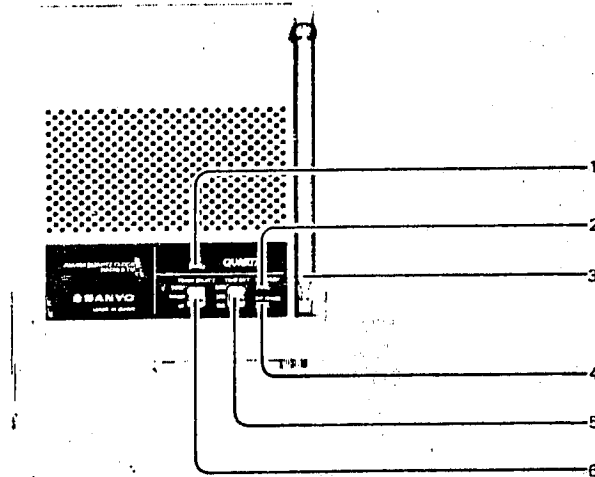

MECHANICAL DISASSEMBLIES

CABINET TOP REMOVAL

1. Place the TV set upside down on a soft surface.
2. Remove three screws as indicated in Figure 1.
3. Open the battery compartment lid of the rear of the TV set by sliding it in the direction as indicated in Figure 2.
4. Push the two hooks in the direction of the arrow as indicated in Figure 3, and lift the Cabinet Top away from TV set. (NOTE: Be careful of the Rod Antenna and Handle, when you lift the Cabinet Top).

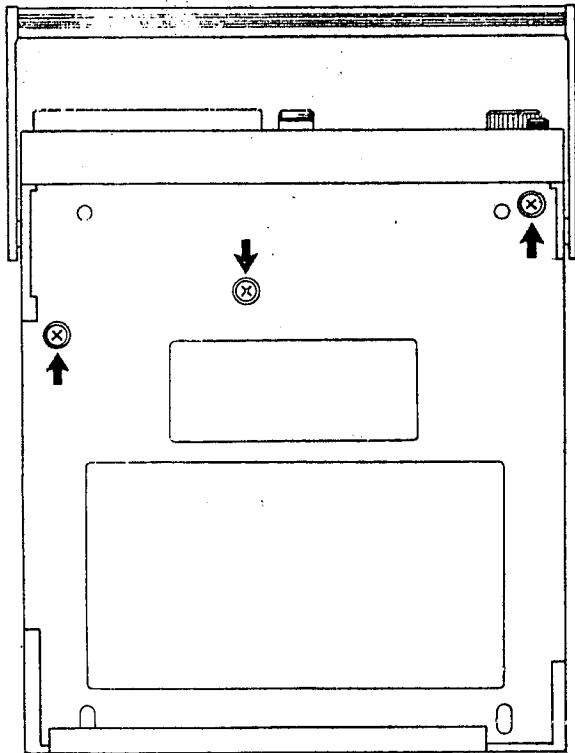
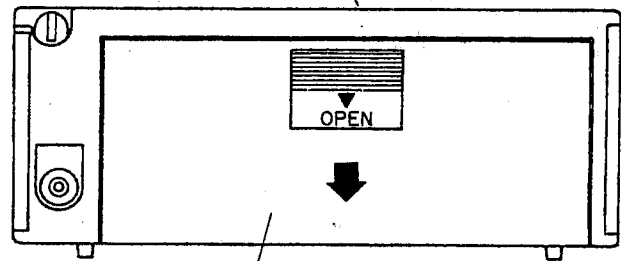

Figure 1



Battery compartment lid

Figure 2

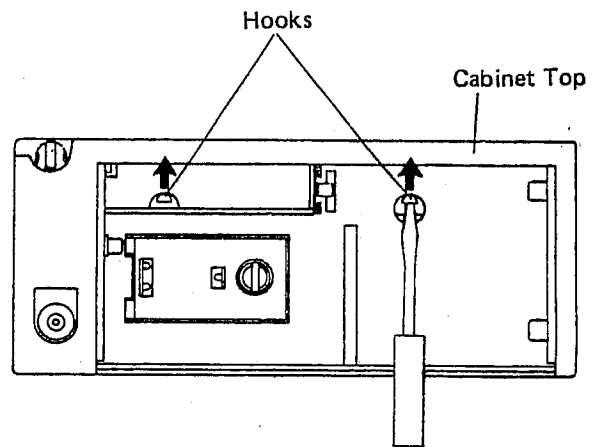

Figure 3

RADIO P.C.B. REMOVAL

1. Remove Cabinet Top (Refer to CABINET TOP REMOVAL).
2. Take out two knobs (TV-RADIO SELECT, TV SELECT).
3. Remove three screws as indicated in Figure 4.
4. Pull out the Side Panel in the direction (A) as indicated in Figure 4.
5. Pull out the Cabinet Front in the direction (B) as indicated in Figure 4.
6. Take out the 3P socket from the TV P.C.B. as indicated in Figure 5.
7. Lift the Radio P.C.B. and Cabinet Front in the direction of the arrow as indicated in Figure 5.
(NOTE: Keep the leads P4(Green), P5(Black) and Volume(Gray) as far as possible from the SF101, when assembling after servicing so that the leads does not pick up any oscillation).

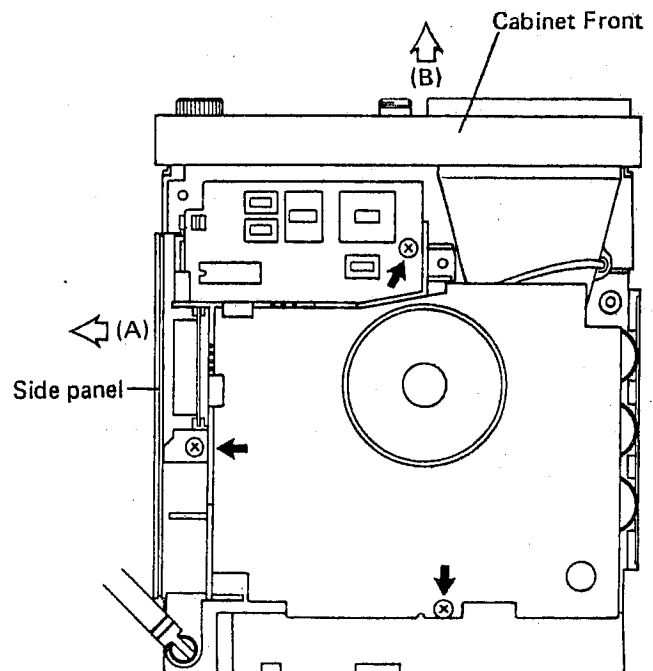

Figure 4

TV P.C.B. REMOVAL

1. Remove the Cabinet Top and Radio P.C.B. by following the instructions for them.
2. Slightly pull the TV P.C.B. in the direction (A) and lift it in the direction (B) of the arrow as indicated in Figure 5. Then, the TV P.C.B. will be removed.

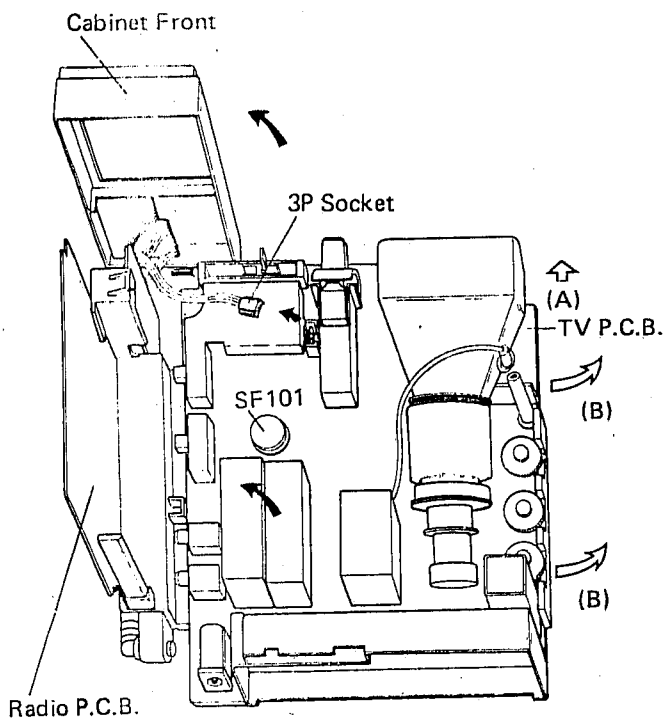

Figure 5

NOTE: When assembling after servicing.

Dress all the leads on Radio P.C.B. to keep away from IC LA4140. Also dress all the leads on TV P.C.B. so that the leads do not cross over to Horizontal Output Trans.

PICTURE TUBE REMOVAL

1. Remove the Cabinet Top and Radio P.C.B. by following the instructions for them.
2. Remove the anode cap and the picture tube socket. Then, slightly loosen the screw securing the Deflection Yoke.
3. Pull the picture tube toward you.
(The Safety Shield can be removed under this condition. However, insert the Safety Shield into the CRT when the CRT is mounted. Be sure there is no accumulation of dust between the picture tube face and the Safety Shield when reinstalling.)
4. After picture tube removal. Place section (A) of the Cabinet Top on Anode Cap of the picture tube, when Cabinet Top assembling as illustrated in Figure 6.

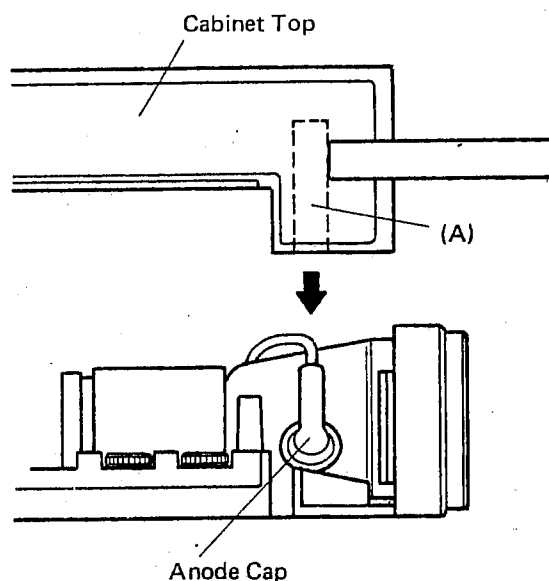

Figure 6

SPEAKER REMOVAL

When you have replaced the Speaker, Do not forget the lead (Black) roll on magnet of the Speaker and apply plenty of cemedine adhesive around the lead as illustrated in Figure 7.

(REASON: To prevent picture distortion when sound maximum).

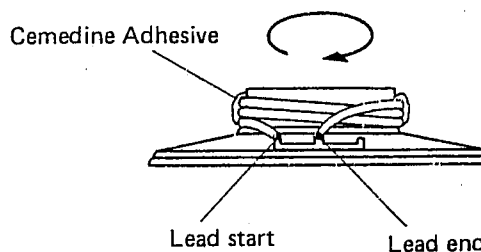

Figure 7

**IMPORTANT NOTICE FOR SERVICE
PERSONNEL BEFORE SERVICING**

PLEASE READ BEFORE ATTEMPTING SERVICE

- 1 The AC power line voltage must be kept within $\pm 10\%$ of the rated voltage.
- 2 DO NOT DISCHARGE, ARC, OR MEASURE HIGH VOLTAGE WHEN HIGH VOLTAGE LEAD IS CONNECTED TO CRT. DISCHARGE 2ND ANODE OF CRT ONLY AFTER HIGH VOLTAGE LEAD HAS BEEN DISCONNECTED. DO NOT DISCHARGE HIGH VOLTAGE LEAD AT ANY TIME, DAMAGE TO TRANSISTORS MAY RESULT.
- 3 While the receiver is in operation, do not attempt to connect or disconnect any wires.
- 4 Disconnect all power before attempting any repairs.
- 5 When the power is on, do not attempt to short any portion of the circuit. This shorting may cause damage to the transistors in the receiver.
- 6 When adjusting Horizontal Oscillator Frequency, do not vary this frequency more than ± 800 Hz from 15,750 Hz center frequency: 800 Hz equals 13 bars.

TELEVISION ADJUSTMENT

PICTURE FOCUS (See Fig. 8)

Adjust focus - VR (FP601) to obtain the best focus. While the adjustment, do not disconnect the picture tube coating earth.

DEFLECTION YOKE AND CENTERING RINGS

- 1 Turn the receiver on and disconnect the antenna.
- 2 Loosen the Deflection Yoke Clamp, and carefully move the yoke on the neck of the picture tube as far forward as possible. Rotate the yoke until the top and bottom edges of the raster are straight. Tighten the clamp.
- 3 Center the raster and eliminate shaded corners by rotating the centering rings until the best effect is obtained.

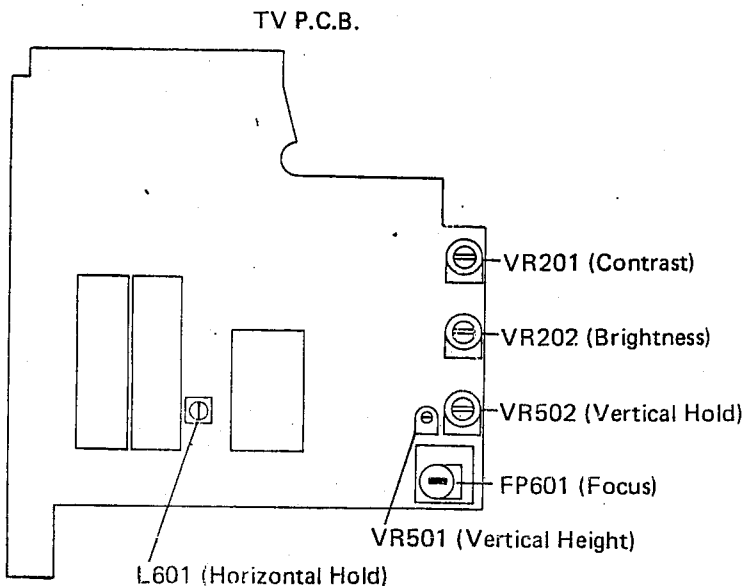

Figure 8

VERTICAL HEIGHT (See Fig. 8)

- 1 Adjust the Height control (VR501) to obtain proper picture height.
- 2 Rotate V - Hold control (VR502) completely clockwise or counterclockwise to confirm the picture rolls up or down at both extreme positions.

HORIZONTAL HOLD CONTROL (See Fig. 8)

Adjust the H - Hold control (L601) to corrects any slanting of the picture.

SOUND IF ALIGNMENT PROCEDURE (See Fig. 9)

- 1 Set the TV System switch to UK position (SW01).
- 2 Set the Signal Generator to 6.0MHz, FM 1KHz \pm 15KHz dev. and Sig. Gen. output 110db.
- 3 Connect the Signal Generator through 4700pF to P4,VTVM to Q (R305) respectively.
- 4 Set the TV Tuning Knob to unused channel.
- 5 Adjust T301 for maximum reading on VTVM.
- 6 Set the Signal Generator to 6.0MHz, AM 1KHz \pm 30%dev, and Sig. Gen. output 40db \pm 10db for maximum reading on VTVM, then adjust T301 for minimum reading on VTVM.
- 7 Set the TV System switch to EUR position (SW01).
- 8 Set the Signal Generator to 5.5MHz, AM 1KHz \pm 30%dev, and Sig. Gen. output 40db \pm 10db for maximum reading on VTVM, then adjust CT302 for minimum reading on VTVM.
- 9 Set the TV System switch to US position (SW01).
- 10 Set the Signal Generator to 4.5MHz, AM 1KHz \pm 30%dev, and Sig. Gen. output 40db \pm 10db for maximum reading on VTVM, then adjust CT301 for minimum reading on VTVM.

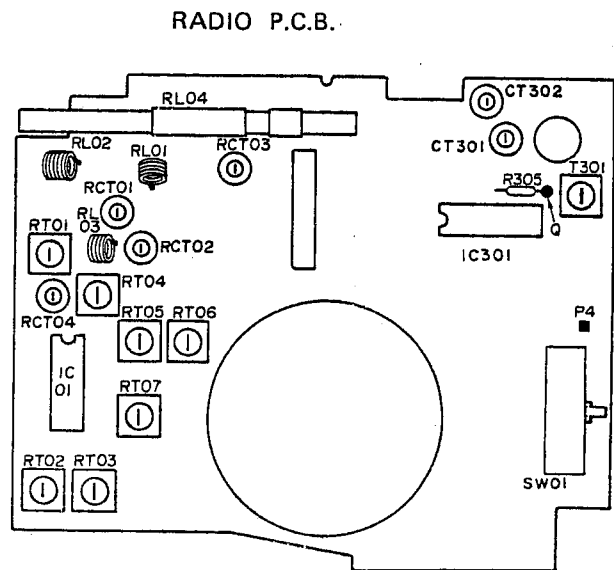

Figure 9

HANDLING AND REPAIRING OF LCD QUARTZ CLOCK P.C.B.

HANDLING OF LCD QUARTZ CLOCK P.C.B. (MODULE & CONTROL UNIT)

1. LCD Quartz Clock uses C-MOS LSI and C-MOS IC. These LSI and IC are very sensitive to static electricity and can be easily damaged by the static electricity. Therefore, give a proper protection to the Clock P.C.B. when handling it.
2. As LCD is very weak against ultraviolet rays, do not expose the watch to direct sunlight or extremely hot temperatures.
3. The polarized plate is attached on the surface of LCD to make letter contrasts. As the plate can easily be scratched, pay due caution when handling it.
4. Strong shock on the surface of LCD will cause defective electrical contacts and time display.
5. After attaching LCD to the unit, wipe the surface of LCD clean with a soft cloth to prevent it from electrification.
6. Do not touch the P.C.B. pattern directly. Hold the both ends of the P.C.B.

MODUL UNIT P.C.B.

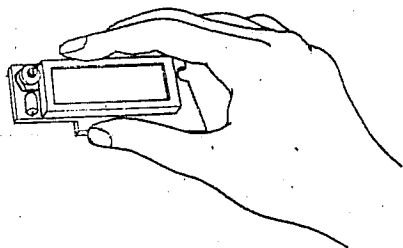

LCD QUARTZ CLOCK P.C.B. STORAGE

1. Store the watch in an ambient temperature of 0°C – 50°C and low humidity. Also keep it in a dark place.
2. Do not unwrap the package of the parts before use.
3. Completed LCD Quartz Clock P.C.B. and LCD Quartz Clock Control Unit are prepared as repair parts.

NOTES ON CLOCK P.C.B. REPAIR

1. Spread the conductive sheet on the worktable and ground it. Perform the repair work on the table.

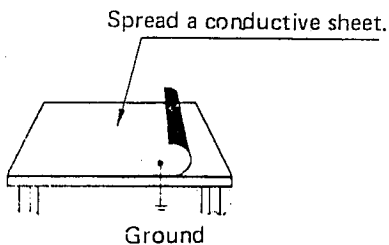

2. Use a soldering iron for IC (Insulation resistance: 300M-ohm) or ground the ordinary soldering iron to prevent alternate current leakage.
3. When performing a repair work, wear the grounded

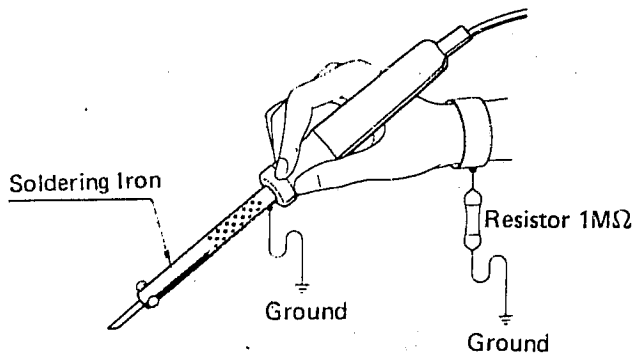

conductive bracelet with 1M-ohm resistor.

4. Ground the meter body to avoid electrification.
5. Do not use the resistance range at the measurement by the tester.
6. Take out the five dry batteries and a silver oxide battery. Then, remove the LCD Quartz Clock P.C.B. following the disassembly method.
7. Discharge the electric potential by shorting the +B line and -B line in the Clock Control Unit. Then, ground the +B line.

CONTROL UNIT P.C.B.

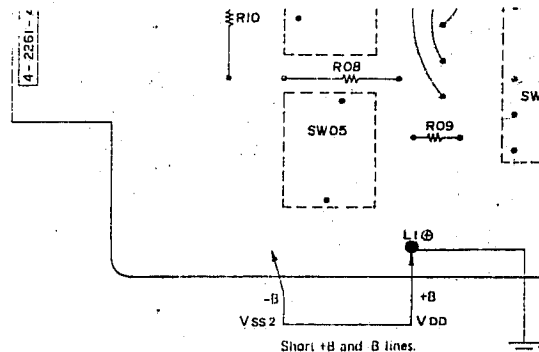

REPAIR OF LCD QUARTZ WATCH

- Before repair work, check to see that the silver oxide battery is correctly set in the battery holder and that the leads connected to the Watch P.C.B. are not broken.
- When any trouble on the watch display is caused, replace the completed LCD Quartz Clock P.C.B. or the LCD Quartz Control Unit with a new one.
- Replace them when the following troubles appear.
 1. LCD display does not appear when the battery is replaced with a new one.
 2. A part of the digital display is missing as illustrated.

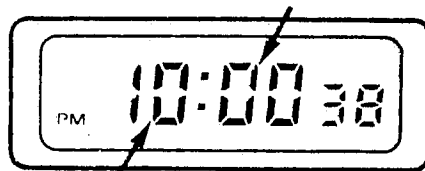

3. Time display is skipped over as illustrated.



AM RADIO ALIGNMENT PROCEDURE

CONNECTION OF THE MEASURING INSTRUMENTS

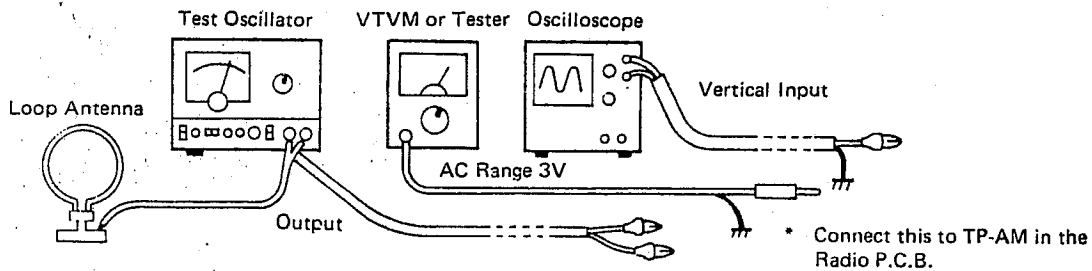

* Bring the output cord of the test oscillator close to the Bar Antenna.

PRELIMINARIES

- 1 Oscilloscope is set to prevent the waveform from saturating and to obtain peak value.
- 2 Set the VTVM to the 3V, AC range.
- 3 Modulate the test oscillator at 1KHz and set the degree of modulation to approximately 30% if the modulation degree is variable.

AM IF ADJUSTMENT (460KHz Adjustment)

- 1 Set the test oscillator to 460KHz.
 - 2 Adjust the cores of IFT, RT05, RT06 and RT07 for maximum reading on VTVM. (Repeat the adjustment two or three times.)
- * Keep the output of the test oscillator as low as possible. Check to see that the waveform is not saturated by using the oscilloscope.

AM TRACKING ADJUSTMENT

- 1 Remove the paraffin fastening the coil of the bar antenna (RL04), so that the coil can be moved.
 - 2 Set the test oscillator and the Radio Dial to 600KHz.
 - 3 Move the coil of the bar antenna for maximum oscilloscope waveform and VTVM indication.
* After adjustment, fasten the coil with paraffin.
 - 4 Set the test oscillator and the Radio Dial to 1400KHz.
 - 5 Adjust the trimmer capacitor (RCT03) of the variable capacitor for maximum oscilloscope waveform and VTVM indication.
- * Repeat the AM frequency range and AM tracking adjustments two or three times.

AM FREQUENCY RANGE ADJUSTMENT

(Adjustment to cover 530KHz - 1605KHz)

- 1 Set the test oscillator to 505KHz.
- 2 Turn the Radio Tuning Knob to the lower frequency (Tuning Capacitor plates fully meshed).
- 3 Adjust the core of RT04 for maximum oscilloscope waveform and VTVM indication.
- 4 Set the test oscillator to 1650KHz.
- 5 Turn the Radio Tuning Knob to the highest frequency (Tuning Capacitor plates fully open).
- 6 Adjust the trimmer capacitor (RCT04) of the variable capacitor for maximum oscilloscope waveform and VTVM indication.

RADIO CHASSIS TOP VIEW

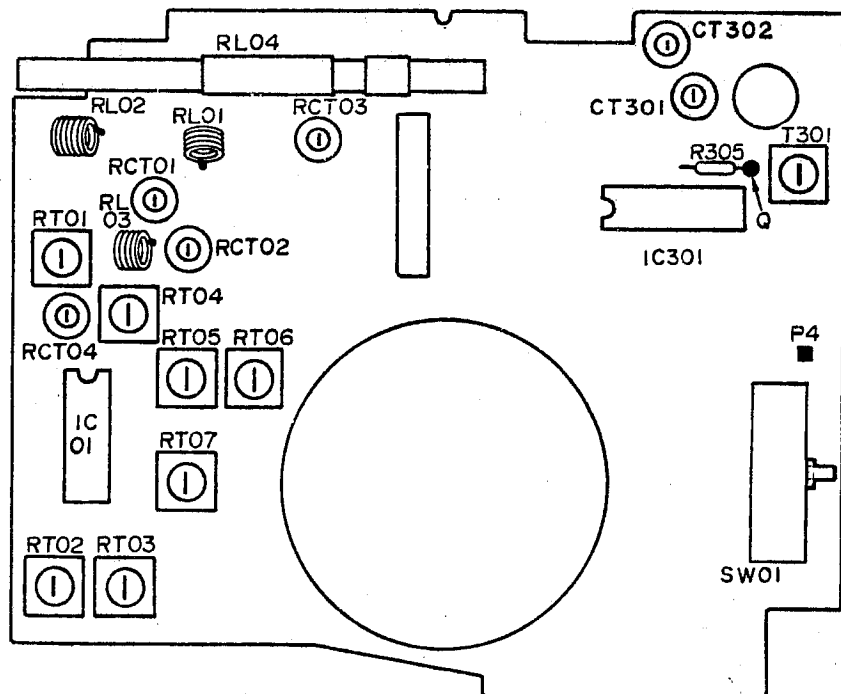

FM RADIO ALIGNMENT PROCEDURE

CONNECTION OF THE MEASURING INSTRUMENTS

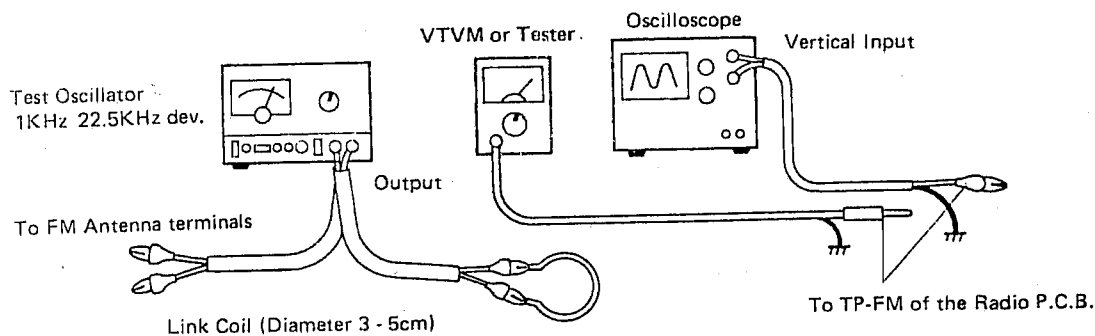

PRELIMINARIES

- 1 Set the VTVM to the 3V, AC range.
- 2 Make a link coil of diameter 3 - 5cm(2") as illustrated for the test oscillator output and set it on Q02 or RL02 when FM IF adjustments are performed. Connect the oscillator output to the FM antenna terminals for some other adjustments.

FM IF ADJUSTMENT (10.7MHz Adjustment)

- 1 Set the link coil on RL02.
- 2 Set the test oscillator to 10.7MHz and adjust IFT RT02 for maximum on the VTVM.
- 3 Minimize the test oscillator output as much as possible and adjust IFT RT01, RT02 and RL02 for maximum on the VTVM.
 - * Repeat the adjustment two or three times.
- 4 Adjust IFT RT03 for maximum on the VTVM.
- 5 Check to see that the indications of VTVM is identical. If not, repeat steps 2 - 4.

FM FREQUENCY RANGE ADJUSTMENT

(Adjustment to cover 87.5MHz - 108MHz)

- 1 Set the test oscillator to 87.25MHz and connect it to the FM terminals.
- 2 Turn the Radio Tuning Knob to the lower frequency (Tuning Capacitor plates fully meshed).
- 3 Adjust RL03 for maximum indication on the oscilloscope and VTVM.
 - * After adjustment, secure RL03 with paraffin.
- 4 Set the test oscillator to 108.40MHz and turn the Radio Tuning Knob to the higher frequency (Tuning Capacitor plates fully open).
- 5 Adjust the trimmer capacitor RCT02 on the variable capacitor for maximum indication on the oscilloscope and VTVM.

FM TRACKING ADJUSTMENT

- 1 Set the test oscillator to 90.0MHz and connect the output to the FM antenna terminals.
- 2 Set the Radio Dial to 90.0MHz and adjust RL01 and RL02 for maximum.
 - * After adjustment, secure RL01 and RL02 with paraffin.
- 3 Set the test oscillator and the Radio Dial to 105.0MHz.
- 4 Adjust the trimmer capacitor RCT01 of the variable capacitor for maximum oscilloscope waveform and VTVM indication.
 - * Repeat the FM Frequency range and FM tracking adjustments two or three times.

SCHEMATIC DIAGRAM (TUNER)

VHF TUNER
4-1151-07740

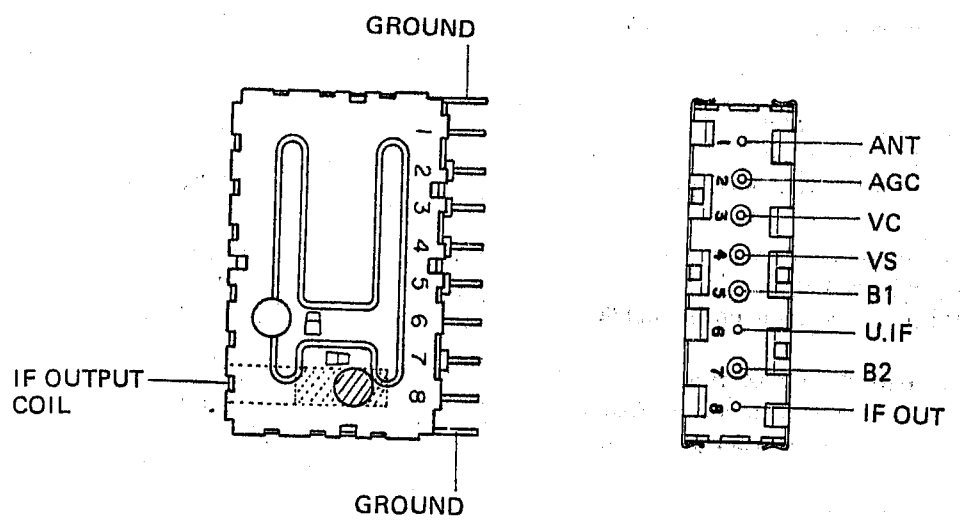
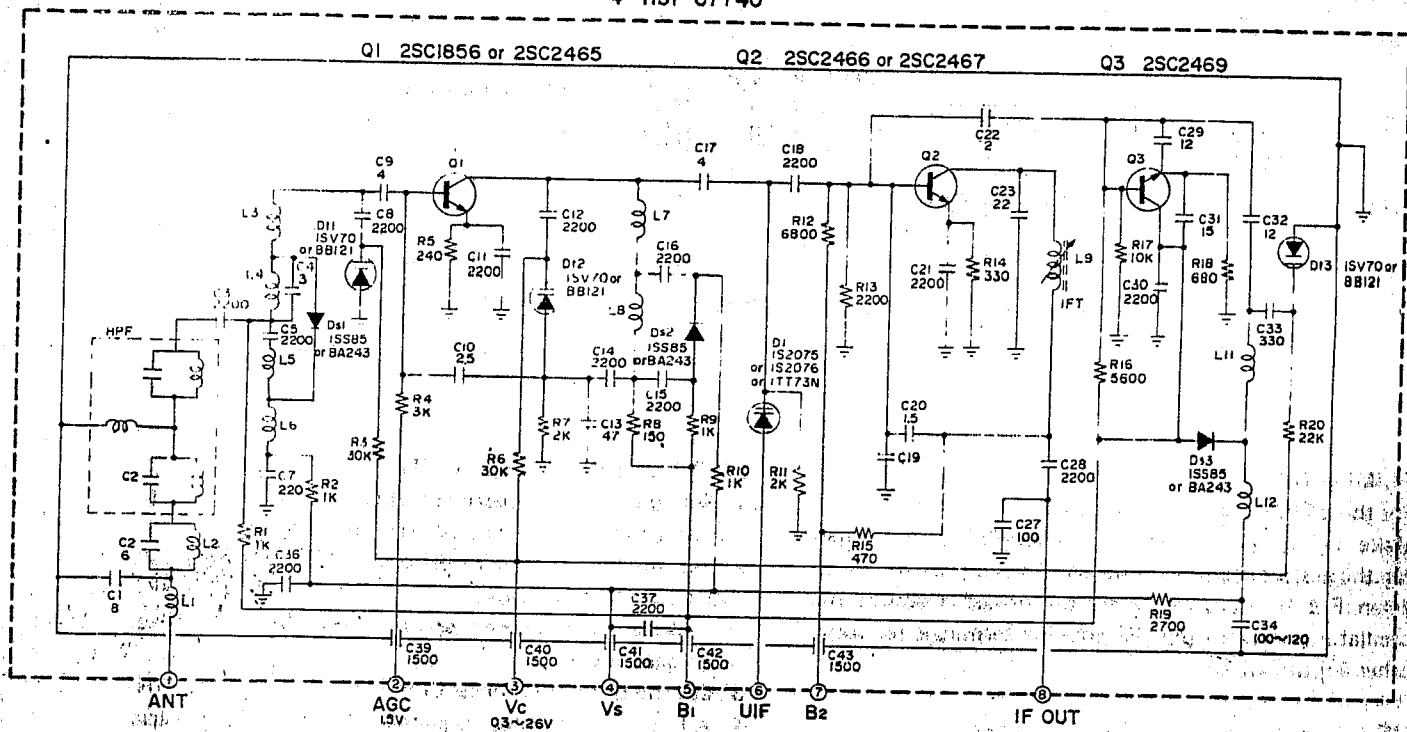

PICTORIAL OF VHF TUNER

UHF TUNER
4-1151-46540

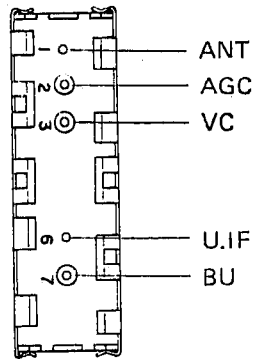
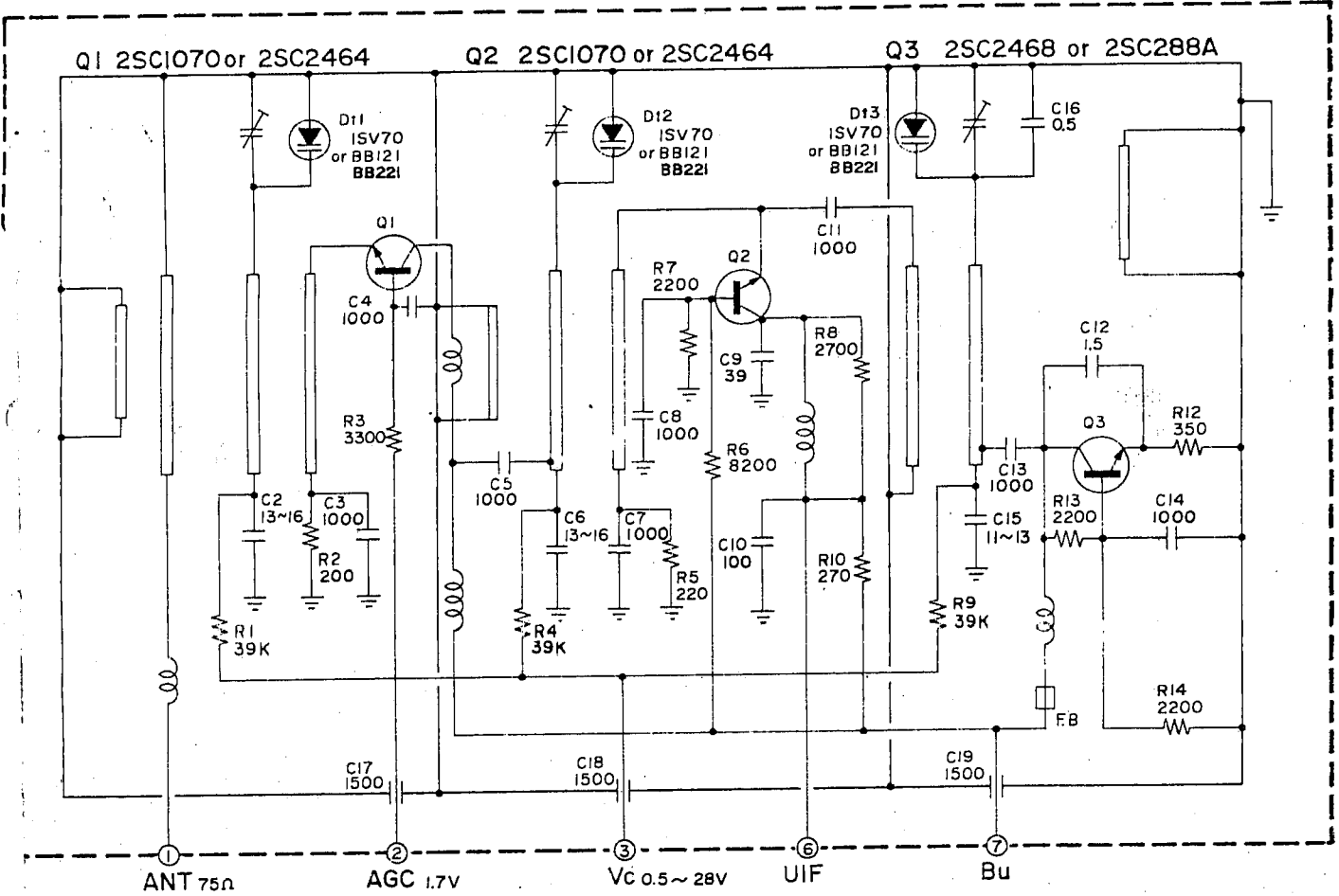

PICTORIAL OF UHF TUNER

REPLACEMENT PARTS LIST

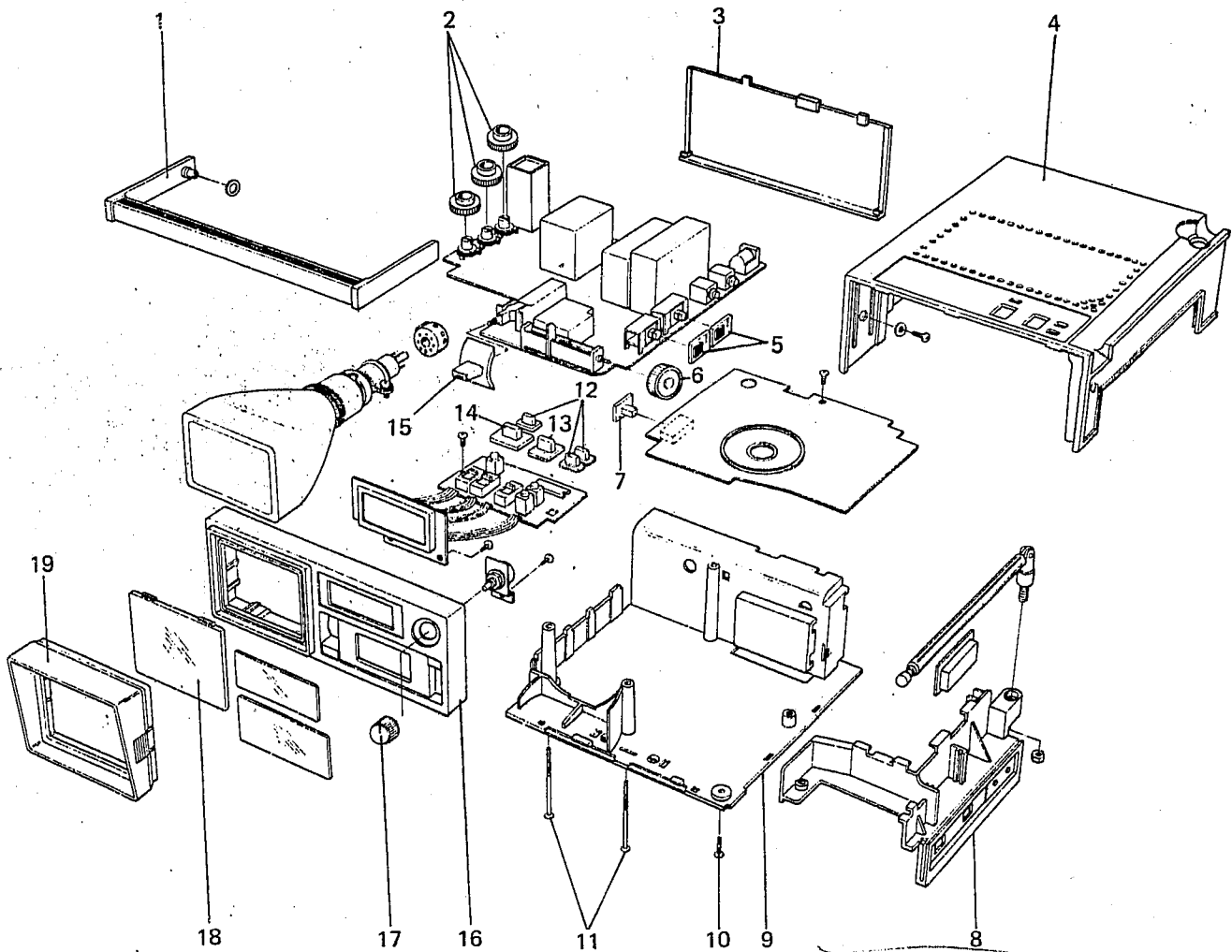

N.L.A.

Key No.	Parts No.	Description	Q'ty
1	111 0 1711 07170	HANDLE ASSY-TMF	1
2	111 2 1641 24770	TV CONTROL KNOB-TMF	3
3	111 2 1161 18872	BATTERY COVER-TMF-A1	1
4	111 0 1161 16973	CAB TOP ASSY-TMF-A2	1
5	111 2 1641 25070	SELECT KNOB-TMF	2
6	111 2 1631 18270	TUNING KNOB-TMF	1
7	111 2 1641 24970	E/A SELECT KNOB-TMF	1
8	111 2 1241 12072	SIDE PANEL-TMF-A1	1
9	111 0 1161 17075	CAB BOT ASSY-TMF-A4	1
10	111 2 4211 15270	BTP, 3.0x12, C2	1
11	111 2 4211 15070	SUS BTP 3.0x40	2
12	111 2 1641 24470	TIME SET BUTTON-TMF	3
13	111 2 1641 24570	TIMER SW KNOB-TMF	1
14	111 2 1641 25170	TIMER SW KNOB-TMF-B	1
15	111 2 1641 24870	POWER SW KNOB-TMF	1
16	111 0 1121 10573	CAB FR ASSY-TMF-A2	1
17	111 2 1641 24670	VOLUME KNOB-TMF	1
18	111 2 1141 15270	SAFETY SHIELD-TMF	1
19	111 2 6151 10370	HOOD-TMF	1

PARTS LIST

Schematic Location	Parts No.	Description	Q'ty	Schematic Location	Parts No.	Description	Q'ty
CHASSIS PARTS							
	111 2 5291 12670	CLO PCB HOLDER-TMF	1	SW02	4 2311 10670	LEVER SWITCH	1
	111 2 6111 27570	TV SHIELD CASE-TMF	1		4 2351 05770	CRT SOCKET	1
	111 2 6111 27670	TV SHLD CASE TOP-TMF	1		4 2351 74570	1P DC JACK-E	1
	111 2 6111 27770	TV SHLD CASE BOT-TMF	1		4 2361 14570	3P M MICRO PLUG	2
	111 2 6211 24370	RADIATOR PLATE-TMF	1		4 2361 14670	1P MICRO PLUG	6
	111 2 6231 15670	CRT EARTH TIP-TMF	1		4 2441 06570	ROD ANTENNA <i>N.L.A.</i>	1
	111 2 7311 34370	TV PCB INS SHEET-TMF	1	P2	111 0 9081 01011	1P MICRO SOCKET ASSY	1
				P7	111 0 9081 01012	1P MICRO SOCKET ASSY	1
				P8	111 0 9081 01013	1P MICRO SOCKET ASSY	1
				P10,11	111 0 9081 01019	1P MICRO SOCKET ASSY	2
				P12,13	111 0 9081 01020	1P MICRO SOCKET ASSY	2
					111 0 9081 03037	3P NI-CD PLUG ASSY	1
PACKING MATERIALS							
	111 6 1131 21472	OUT CORR CASE-TMF-JC	1	VARIABLE RESISTORS			
	111 6 1411 12272	IND CASE-TMF-JC	1	VR001	4 2221 33770	TUNING VR B-100K	1
	111 6 2511 19670	IND POLY COVER-MBA	1	VR201	4 2221 33870	9CVFR9B-5K	1
	111 6 3111 55170	TOP INNER CUSH-TMF-C	1	VR202	4 2221 33970	9CVFR9B-200K	1
	111 6 3111 55270	BOT INNER CUSH-TMF-C	1	VR501	4 2221 34170	6CVFRB-2M	1
	111 6 3911 11070	TOP PAD-TMF. J	2	VR502	4 2221 34070	9CVFR9B-2M	1
ACCESSORIES AND LABELS				CAPACITORS			
	4 6611 00270	S-OXIDE BAT G12	1	C001	C1EYDK102C--	CERAMIC 1000P C 25V	1
	111 0 1771 10170	SHOULDER BELT ASSY	1	C002	C1EYDK102C--	CERAMIC 1000P C 25V	1
	111 0 6151 10170	HOOD ASSY-TMF	1	C003	COJRE-476A--	ELECT 47M 6.3V	1
	111 0 9021 04170	CONVERSION PLUG ASSY	1	C101	C1HYDK102W--	CERAMIC 1000P W 50V	1
	4645 111 0 9131 15000	AC ADAPTOR ASSY	1	C102	C1HCDJ680RH-	CERAMIC 68P RH 50V	1
	111 2 1811 10472	CARRING CASE-TMF-C	1	C103	C1HYDK102W--	CERAMIC 1000P W 50V	1
	111 6 2701 14304	PM ASSY TMF-E	1	C104	C1HYDK102W--	CERAMIC 1000P W 50V	1
	111 6 2711 05870	ENVELOPE-SR-C	(1)	C105	C1HYDK102W--	CERAMIC 1000P W 50V	1
	111 6 4111 97874	INST MANUAL-TMF-E	(1)	C106	C1HCDJ390RH-	CERAMIC 39P RH 50V	1
	111 6 4211 26065	SCHEMATIC DIAG-9J	(1)	C107	C1HYDK102W--	CERAMIC 1000P W 50V	1
	111 0 9121 06370	EARPHONE	(1)	C108	C1HCDJ820RH-	CERAMIC 82P RH 50V	1
	111 6 2711 05870	ENVELOPE-SR-C	1	C109	C1HYDK102W--	CERAMIC 1000P W 50V	1
	111 6 4551 18770	SERIAL NO LABEL-TJP	2	C110	C1HCDJ820RH-	CERAMIC 82P RH 50V	1
SCREWS-CABINET							
	101 3 1102 60401	SNB . 2.6X 4.Z1	2	C111	C1HCDD100RH-	CERAMIC 10P RH 50V	1
	102 3 2203 00601	SBT . 3.0X 6.Z1	2	C112	C1HCDD100RH-	CERAMIC 10P RH 50V	1
	102 3 2203 00802	SBT . 3.0X 8.Z1	3	C113	C1HCDD100RH-	CERAMIC 10P RH 50V	1
	102 3 2203 01001	SBT . 3.0X 10.Z1	1	C114	C1EYDK473C--	CERAMIC 0.047M C 25V	1
	104 3 1103 00005	ZRN 1. 3.0.	1	C115	C1EYDK473C--	CERAMIC 0.047M C 25V	1
	111 2 4211 15070	SUS BTP 2.3.0X40	2	C116	C1EYDK473C--	CERAMIC 0.047M C 25V	1
	111 2 4211 15270	BTP 2.3.0X12.C2	1	C117	COJRE-227A--	ELECT 220M 6.3V	1
SCREWS-CHASSIS							
	101 3 1103 00802	SNB . 3.0X 8.Z1	1	C118	C1CRE-106A--	ELECT 10M 16V	1
	102 3 2203 00802	SBT . 3.0X 8.Z1	2	C119	C1HRE-105A--	ELECT 1M 50V	1
	104 3 1103 00006	SRN 1. 3.0.	1	C120	COJRE-476A--	ELECT 47M 6.3V	1
	111 3 1103 00803	SBW . 3.0X 8.0X05Z1	1	C121	C1EYDK473C--	CERAMIC 0.047M C 25V	1
ELECTRICAL PARTS							
	4 1151 07740	VHF TUNER	1	C122	C1EYDK473C--	CERAMIC 0.047M C 25V	1
	4 1151 46540	UHF TUNER	1	C123	C1HRE-105A--	ELECT 1M 50V	1
	4 1511 09370	SPEAKER	1	C124	C1HYDP103Z--	CERAMIC 10000P Z 50V	1
	4 2531 12570	U-V FILTER	1	C125	C1HYDP103Z--	CERAMIC 10000P Z 50V	1
	4 9541 00170	LCD CLOCK DQ436	1	C126	C1EYDK473C--	CERAMIC 0.047M C 25V	1
	111 0 9061 42870	CLOCK CONTROL UNIT	1	C127	C1EYDK473C--	CERAMIC 0.047M C 25V	1
	111 0 9061 43371	OSC BLOCK UNIT	1	C202	COJTDMA476A--	TANTAL 47M 6.3V	1
FP601	4 1911 06070	FOCUS PACK	1	C203	C1HYDK471W--	CERAMIC 470P W 50V	1
L001	4 2531 12870	FILTER COIL 0.33UH	1	C204	COJRE-107A--	ELECT 100M 6.3V	1
L101	4 2531 15170	FILTER COIL 0.56UH	1	C205	C1HDRK104C--	M-CERAMIC 0.1M 50V	1
L102	4 2531 15470	FILTER COIL 1.2UH	1	C401	C1HRE-105A--	ELECT 1M 50V	1
L103	4 2531 13470	FILTER COIL 39MHZ	1	C402	C1EYDK223C--	CERAMIC 0.022M C 25V	1
L104	4 2531 13570	FILTER COIL 78MHZ	1	C403	C1EYDK223C--	CERAMIC 0.022M C 25V	1
L105	4 2721 02209	PEAKING COIL 220	1	C501	C1EYDK473C--	CERAMIC 0.047M C 25V	1
L106	4 2531 15870	FILTER COIL 0.56UH	1	C502	C1VTDK224A--	TANTAL 0.22M 35V	1
L201	4 2531 15770	FILTER COIL 2.2UH	1	C503	C1HDRK104C--	M-CERAMIC 0.1M 50V	1
L601	4 2731 06070	HORIZ OSC COIL	1	C504	C1HRE-105A--	ELECT 1M 50V	1
L602	4 2761 49870	DEFLECTION YOKE	1	C505	C1EYDK223C--	CERAMIC 0.022M C 25V	1
SF101	4 2531 12423	SAW FILTER	1	C506	C1HYDK102W--	CERAMIC 1000P W 50V	1
T601	4 2751 48800	FLYBACK TRANS	1	C507	C1HYDK561W--	CERAMIC 560P W 50V	1
X201	4 2531 10570	CERAMIC TRAP 4.5M	1	C508	C1HDRK104C--	M-CERAMIC 0.1M 50V	1
X202	4 2531 10670	CERAMIC TRAP 5.5M	1	C509	COJRE-477A--	ELECT 470M 6.3V	1
SMALL PARTS							
	4 2261 42671	PC BOARD 9JC-P	1	C510	COJRE-476A--	ELECT 47M 6.3V	1
	4 2261 43771	PC BOARD 9JC-U	1	C512	C1HDRK823C--	M-CERAMIC 0.082M 50V	1
SW03,04	4 2311 10370	SLIDE SWITCH	2	C513	C1HDRK154C--	M-CERAMIC 0.15M 50V	1
				C514	C1HDRK154C--	M-CERAMIC 0.15M 50V	1
				C515	COJRE-108A--	ELECT 1000M 6.3V	1
				C516	C1HDRK823C--	M-CERAMIC 0.082M 50V	1
				C601	C1EYDK332C--	CERAMIC 3300P C 25V	1
				C602	C1HFRK472A--	MYLAR 0.0047M 50V	1
				C603	C1HFRK472A--	MYLAR 0.0047M 50V	1

- NOTICE: 1. Parts orders must contain Model Number, Parts Number and Description.
 2. Ordering quantity of resistors must be multiple of 10pcs.
 3. Component parts indicated by parentheses in the column Q'ty are not available.

PARTS LIST

Schematic Location	Parts No.	Description	Q'ty	Schematic Location	Parts No.	Description	Q'ty
C604	C1HDK104C--	M-CERAMIC 0.1M 50V	1	R407	R2BSUJ123A	CARBON 12K 1/8WJ	1
C605	C1ERE-475A--	ELECT 4.7M 25V	1	R501	R2ESPJ5R6A	CARBON 5.6 1/4WJ	1
C606	C1HFRJ183A--	MYLAR 0.018M 50V	1	R502	R2BSUJ472A	CARBON 4.7K 1/8WJ	1
C607	C1HDK104C--	M-CERAMIC 0.1M 50V	1	R503	R2BSPJ124A	CARBON 120K 1/8WJ	1
C608	COJRE-476A--	ELECT 47M 6.3V	1	R504	R2BSPJ334A	CARBON 330K 1/8WJ	1
C609	C1CRE-106A--	ELECT 10M 16V	1	R505	R2BSUJ101A	CARBON 100 1/8WJ	1
C610	C2AGRJ273A--	POLYPR 0.027M 100V	1	R506	R2BSPJ394A	CARBON 390K 1/8WJ	1
C611	C2HYDK102W--	CERAMIC 1000P W 500V	1	R507	R2BSPJ105A	CARBON 1M 1/8WJ	1
C612	COJRE-477A--	ELECT 470M 6.3V	1	R508	R2BSPJ104A	CARBON 100K 1/8WJ	1
C613	C1HRE-475A--	ELECT 4.7M 50V	1	R509	R2BSPJ394A	CARBON 390K 1/8WJ	1
C614	C1ERE-475A--	ELECT 4.7M 25V	1	R510	R2BSPJ124A	CARBON 120K 1/8WJ	1
C615	C1HRE-105A--	ELECT 1M 50V	1	R511	R2BSPJ823A	CARBON 82K 1/8WJ	1
C616	C1HFRK473A--	MYLAR 0.047M 50V	1	R512	R2BSPJ333A	CARBON 33K 1/8WJ	1
C617	C1HFRK223A--	MYLAR 0.022M 50V	1	R513	R2BSPJ220A	CARBON 22 1/8WJ	1
C620	C1HYDK561W--	CERAMIC 560P W 50V	1	R514	R2BSUJ562A	CARBON 5.6K 1/8WJ	1
C621	C3AKDP472Z--	CERAMIC 4700P Z 1KV	1	R515	R2BSUJ221A	CARBON 220 1/8WJ	1
C701	C1CRE-106A--	ELECT 10M 16V	1	R516	R2BSUJ224A	CARBON 220K 1/8WJ	1
C702	C1EYDK473C--	CERAMIC 0.047M C 25V	1	R517	R2BSUJ184A	CARBON 180K 1/8WJ	1
C703	C1EYDK473C--	CERAMIC 0.047M C 25V	1	R518	R2BSUJ473A	CARBON 47K 1/8WJ	1
C704	C1CRE-476A--	ELECT 47M 16V	1	R519	R2BSUJ2R2A	CARBON 2.2 1/8WJ	1
				R520	R2BSUJ8R2A	CARBON 8.2 1/8WJ	1
				R521	R2BSUJ473A	CARBON 47K 1/8WJ	1
				R522	R2BSUJ220A	CARBON 22 1/8WJ	1
				R523	R2BSPJ824A	CARBON 820K 1/8WJ	1
				R601	R2BSUJ561A	CARBON 560 1/8WJ	1
				R602	R2BSUJ103A	CARBON 10K 1/8WJ	1
				R603	R2BSUJ392A	CARBON 3.9K 1/8WJ	1
				R604	R2BSUJ102A	CARBON 1K 1/8WJ	1
				R605	R2BSUJ222A	CARBON 2.2K 1/8WJ	1
				R606	R2BSUJ472A	CARBON 4.7K 1/8WJ	1
				R607	R2BSUJ183A	CARBON 18K 1/8WJ	1
				R608	R2BSUJ390A	CARBON 39 1/8WJ	1
				R609	R2BSUJ121A	CARBON 120 1/8WJ	1
				R610	R2BSPJ471A	CARBON 470 1/8WJ	1
				R611	R2BSUJ101A	CARBON 100 1/8WJ	1
				R612	R2BSUJ821A	CARBON 820 1/8WJ	1
				R613	R2BSUJ100A	CARBON 10 1/8WJ	1
				R614	R2BSPJ183A	CARBON 18K 1/8WJ	1
				R615	R2BSPJ472A	CARBON 4.7K 1/8WJ	1
				R616	R2BSUJ472A	CARBON 4.7K 1/8WJ	1
				R617	R2BSUJ471A	CARBON 470 1/8WJ	1
				R618	R2BSUJ182A	CARBON 1.8K 1/8WJ	1
				R619	R2BSPJ564A	CARBON 560K 1/8WJ	1
				R701	R2HCPK101A	SOLID 100 1/2WK	1
				R702	R2BSPJ222A	CARBON 2.2K 1/8WJ	1
				R703	R2BSPJ122A	CARBON 1.2K 1/8WJ	1
				R705	R2BSUJ221A	CARBON 220 1/8WJ	1
FIXED RESISTORS				TUBES AND SEMICONDUCTORS			
R001	R2BSUJ222A	CARBON 2.2K 1/8WJ	1	D001	4 2021 18770	SI DIODE MA56	1
R002	R2BSUJ472A	CARBON 4.7K 1/8WJ	1	D101	4 2021 07470	SI DIODE 1S2076	1
R003	R2BSUJ222A	CARBON 2.2K 1/8WJ	1	D102	4 2021 07470	SI DIODE 1S2076	1
R101	R2BSUJ123A	CARBON 12K 1/8WJ	1	D103	4 2020 03500	GE DIODE 1S188TV	1
R102	R2BSUJ272A	CARBON 2.7K 1/8WJ	1	D104	4 2020 03500	GE DIODE 1S188TV	1
R104	R2BSUJ221A	CARBON 220 1/8WJ	1	D501	4 2021 07470	SI DIODE 1S2076	1
R105	R2BSUJ561A	CARBON 560 1/8WJ	1	D502	4 2021 07470	SI DIODE 1S2076	1
R106	R2BSUJ101A	CARBON 100 1/8WJ	1	D503	4 2021 07470	SI DIODE 1S2076	1
R107	R2BSUJ123A	CARBON 12K 1/8WJ	1	D601	4 2020 03500	GE DIODE 1S188TV	1
R108	R2BSUJ272A	CARBON 2.7K 1/8WJ	1	D602	4 2020 03500	GE DIODE 1S188TV	1
R109	R2BSUJ221A	CARBON 220 1/8WJ	1	D603	4 2020 03500	GE DIODE 1S188TV	1
R110	R2BSUJ682A	CARBON 6.8K 1/8WJ	1	D604	4 2021 17370	SI DIODE W09C	1
R111	R2BSUJ152A	CARBON 1.5K 1/8WJ	1	D605	4 2021 07670	SI DIODE 1S2076A	1
R112	R2BSPJ121A	CARBON 120 1/8WJ	1	D606	4 2021 07670	SI DIODE 1S2076A	1
R113	R2BSUJ123A	CARBON 12K 1/8WJ	1	D607	4 2021 07470	SI DIODE 1S2076	1
R114	R2BSUJ222A	CARBON 2.2K 1/8WJ	1	D608	4 2021 20770	ZE DIODE RD4.3E	1
R115	R2BSUJ271A	CARBON 270 1/8WJ	1	D701	4 2020 03500	GE DIODE 1S188TV	1
R116	R2BSUJ182A	CARBON 1.8K 1/8WJ	1	D702	4 2021 21170	ZE DIODE RD7.5EB2	1
R117	R2BSUJ182A	CARBON 1.8K 1/8WJ	1	D703	4 2021 07470	SI DIODE 1S2076	1
R118	R2BSUJ101A	CARBON 100 1/8WJ	1	D704	4 2021 07470	SI DIODE 1S2076	1
R119	R2BSUJ682A	CARBON 6.8K 1/8WJ	1	D705	4 2021 07470	SI DIODE 1S2076	1
R120	R2BSUJ2R2A	CARBON 2.2 1/8WJ	1	IC601	4 2021 10970	IC ZE DIODE UPC574J	1
R121	R2BSUJ152A	CARBON 1.5K 1/8WJ	1	Q101	TG2SC930SPE--	SI TR 2SC930SP	1
R122	R2BSUJ271A	CARBON 270 1/8WJ	1	Q102	TG2SC2057-E1-	SI TR 2SC2057	1
R123	R2BSUJ152A	CARBON 1.5K 1/8WJ	1	Q103	TG2SC930SPE--	SI TR 2SC930SP	1
R124	R2BSUJ183A	CARBON 18K 1/8WJ	1	Q104	TG2SC930SPE--	SI TR 2SC930SP	1
R125	R2BSUJ823A	CARBON 82K 1/8WJ	1				
R126	R2BSUJ332A	CARBON 3.3K 1/8WJ	1				
R127	R2BSUJ821A	CARBON 820 1/8WJ	1				
R128	R2BSUJ223A	CARBON 22K 1/8WJ	1				
R129	R2BSUJ332A	CARBON 3.3K 1/8WJ	1				
R130	R2BSUJ102A	CARBON 1K 1/8WJ	1				
R131	R2BSUJ821A	CARBON 820 1/8WJ	1				
R132	R2BSUJ102A	CARBON 1K 1/8WJ	1				
R201	R2BSUJ220A	CARBON 22 1/8WJ	1				
R202	R2BSUJ821A	CARBON 820 1/8WJ	1				
R203	R2BSUJ820A	CARBON 82 1/8WJ	1				
R204	R2BSPJ682A	CARBON 6.8K 1/8WJ	1				
R205	R2BSPJ392A	CARBON 3.9K 1/8WJ	1				
R206	R2BSPJ122A	CARBON 1.2K 1/8WJ	1				
R207	R2BSUJ102A	CARBON 1K 1/8WJ	1				
R208	R2BSPJ123A	CARBON 12K 1/8WJ	1				
R209	R2BSUJ561A	CARBON 560 1/8WJ	1				
R210	R2BSPJ222A	CARBON 2.2K 1/8WJ	1				
R211	R2BSUJ224A	CARBON 220K 1/8WJ	1				
R212	R2ESPJ225A	CARBON 2.2M 1/4WJ	1				
R213	R2BSUJ222A	CARBON 2.2K 1/8WJ	1				
R401	R2BSUJ101A	CARBON 100 1/8WJ	1				
R402	R2BSUJ561A	CARBON 560 1/8WJ	1				
R403	R2BSUJ224A	CARBON 220K 1/8WJ	1				
R404	R2BSUJ473A	CARBON 47K 1/8WJ	1				
R405	R2BSUJ681A	CARBON 680 1/8WJ	1				
R406	R2BSUJ472A	CARBON 4.7K 1/8WJ	1				

NOTICE:

- Parts orders must contain Model Number, Parts Number and Description.
- Ordering quantity of resistors must be multiple of 10pcs.
- Component parts indicated by parentheses in the column Q'ty are not available.

PARTS LIST

Schematic Location	Parts No.	Description	Q'ty	Schematic Location	Parts No.	Description	Q'ty
Q105	TG2SC930SPE--	SI TR 2SC930SP	1	C325	C1EYDK472C--	CERAMIC 4700P C 25V	1
Q106	TG2SA608SPF--	SI TR 2SA608SP	1	C326	C1EYDK473C--	CERAMIC 0.047M C 25V	1
Q107	TG2SC536SPE--	SI TR 2SC536SP	1	C327	C1HCDK330RH-	CERAMIC 33P RH 50V	1
Q108	TG2SA608SPF--	SI TR 2SA608SP	1	C328	C1HCDC2R0RH-	CERAMIC 2P RH 50V	1
Q201	TG2SC536SP---	SI TR 2SC536SP	1	C329	C1EYDK223C--	CERAMIC 0.022M C 25V	1
or	TT2SC2458-GR-	SI TR 2SC2458	1	C330	C1EYDK223C--	CERAMIC 0.022M C 25V	1
or	TT2SC2458-Y--	SI TR 2SC2458	1	C331	C1EYDK472C--	CERAMIC 4700P C 25V	1
Q202	TG2SC536SP---	SI TR 2SC536SP	1	D301	4 2021 20970	SI DIODE W03A	1
or	TT2SC2458-GR-	SI TR 2SC2458	1	D302	4 2021 20870	ZE DIODE RD5.6EB1	1
or	TT2SC2458-Y--	SI TR 2SC2458	1	D303	4 2021 07470	SI DIODE 1S2076	1
Q203	TN2SC945--P--	SI TR 2SC945	1	D304	4 2021 07470	SI DIODE 1S2076	1
or	TN2SC945--Q--	SI TR 2SC945	1	D305	4 2021 07470	SI DIODE 1S2076	1
Q401	TG2SA608SPE--	SI TR 2SA608SP	1	D306	4 2021 07470	SI DIODE 1S2076	1
Q501	TG2SC536--F--	SI TR 2SC536	1	D307	4 2021 07470	SI DIODE 1S2076	1
Q502	TG2SC536SPF--	SI TR 2SC536SP	1	IC301	4 2061 09670	IC-HA11229	1
or	TT2SC2458-GR-	SI TR 2SC2458	1	IC302	4 2061 09770	IC-LA4140	1
Q503	TG2SC536SPF--	SI TR 2SC536SP	1	L301	4 2721 02209	PEAKING COIL 220	1
or	TT2SC2458-GR-	SI TR 2SC2458	1	L302	4 2591 05370	FM PHASE COIL 68UH	1
Q504	TG2SC536SPF--	SI TR 2SC536SP	1	L303	4 2721 02209	PEAKING COIL 220	1
or	TG2SC536SPG--	SI TR 2SC536SP	1	Q301	TT2SC2236----	SI TR 2SC2236	1
or	TT2SC2458-BL-	SI TR 2SC2458	1	RBPFF1	4 2531 12770	FM BAND PASS FILTER	1
or	TT2SC2458-GR-	SI TR 2SC2458	1	RCF1	4 2531 11871	CERAMIC FILTER 10.7M	1
Q505	TG2SD545--F--	SI TR 2SD545	1	RCT1	4 2241 04770	TRIMMER CAP 7P MAX	1
Q506	TG2SB598--F--	SI TR 2SB598	1	RCT2	4 2241 04570	TRIMMER CAP 20P MAX	1
Q507	TG2SC536SPF--	SI TR 2SC536SP	1	RCT3	4 2241 04770	TRIMMER CAP 7P MAX	1
or	TG2SC536SPG--	SI TR 2SC536SP	1	RCT4	4 2241 04770	TRIMMER CAP 7P MAX	1
or	TT2SC2458-GR-	SI TR 2SC2458	1	RC01	C1EYDK472C--	CERAMIC 4700P C 25V	1
Q601	TG2SC536--F--	SI TR 2SC536	1	RC02	C1EYDK223C--	CERAMIC 0.022M C 25V	1
Q602	TG2SC536SPF--	SI TR 2SC536SP	1	RC03	C1EYDK103C--	CERAMIC 0.01M C 25V	1
or	TG2SC536SPG--	SI TR 2SC536SP	1	RC04	C1EYDK223C--	CERAMIC 0.022M C 25V	1
or	TT2SC2458-GR-	SI TR 2SC2458	1	RC05	C1HCDC2R0RH-	CERAMIC 2P RH 50V	1
Q603	TN2SC2264----	SI TR 2SC2264	1	RC07	C1HCDD5R0RH-	CERAMIC 5P RH 50V	1
Q701	TG2SD826-----	SI TR 2SD826	1	RC08	C1HCDC2R0RH-	CERAMIC 2P RH 50V	1
Q702	TG2SC536SPF--	SI TR 2SC536SP	1	RC09	C1HCDC2R0RH-	CERAMIC 22P RH 50V	1
or	TG2SC536SPG--	SI TR 2SC536SP	1	RC10	C1HYDK221W--	CERAMIC 220P W 50V	1
or	TT2SC2458-GR-	SI TR 2SC2458	1	RC11	C1EYDK103C--	CERAMIC 0.01M C 25V	1
TH101	4 2041 05370	THERMISTOR SDT-35	1	RC12	C1EYDK223C--	CERAMIC 0.022M C 25V	1
TH501	4 2041 04870	THERMISTOR SDT-1000	1	RC13	C1HRE-105A--	ELECT 1M 50V	1
TH502	4 2041 05470	THERMISTOR SDT-02	1	RC14	C1EYDK223C--	CERAMIC 0.022M C 25V	1
TH601	4 2041 04770	THERMISTOR SDT-100	1	RC15	C1EYDK223C--	CERAMIC 0.022M C 25V	1
V201	QEME2225----S	CRT E2225	1	RC16	C1EYDK223C--	CERAMIC 0.022M C 25V	1
or	QNMC205P4----S	CRT C205P4	1	RC17	C1HCDC2R0RH-	CERAMIC 2P RH 50V	1
ELECTRICAL PARTS (RADIO/TV SIF)							
111	0 9181 00472	RADIO ASSY	1	RC18	C1HCDC2R0RH-	CERAMIC 22P RH 50V	1
111	0 9061 42772	RADIO PCB ASSY	1	RC19	C1HCDC150RH-	CERAMIC 15P RH 50V	1
4	2261 42772	PC BOARD 9JC-R2	1	RC20	C1HCDC160RH-	CERAMIC 15P RH 50V	1
4	2361 14670	1P MICRO PLUG	7	RC21	C1EYDK223C--	CERAMIC 0.022M C 25V	1
111	2 3551 26370	VR MTG BRKT-TMF	1	RC22	C1HCDD100RH-	CERAMIC 10P RH 50V	1
CT301	4 2241 04570	TRIMMER CAP 20P MAX	1	RC23	C1EYDK103C--	CERAMIC 0.01M C 25V	1
CT302	4 2241 04570	TRIMMER CAP 20P MAX	1	RC24	C1HCDC6R0RH-	CERAMIC 6P RH 50V	1
C301	C1EYDK223C--	CERAMIC 0.022M C 25V	1	RC25	C1EYDK223C--	CERAMIC 0.022M C 25V	1
C302	COJRE-476A--	ELECT 47M 6.3V	1	RC26	C1EYDK103C--	CERAMIC 0.01M C 25V	1
C303	COJTD476A--	TANTAL 47M 6.3V	1	RC27	C1ERE-475A--	ELECT 4.7M 25V	1
C304	C1ERE-475A--	ELECT 4.7M 25V	1	RC28	C1HYDK221W--	CERAMIC 220P W 50V	1
C305	C1EYDK473C--	CERAMIC 0.047M C 25V	1	RC29	C1HYDK221W--	CERAMIC 220P W 50V	1
C306	C1EYDK103C--	CERAMIC 0.01M C 25V	1	RC30	C1EYDK223C--	CERAMIC 0.022M C 25V	1
C307	C1EYDK103C--	CERAMIC 0.01M C 25V	1	RC31	C1HRE-474A--	ELECT 0.47M 50V	1
C308	C1EYDK473C--	CERAMIC 0.047M C 25V	1	RC32	C1EYDK223C--	CERAMIC 0.022M C 25V	1
C309	C1EYDK103C--	CERAMIC 0.01M C 25V	1	RC33	C1ERE-475A--	ELECT 4.7M 25V	1
C310	C1EYDK473C--	CERAMIC 0.047M C 25V	1	RC34	C1EYDK223C--	CERAMIC 0.022M C 25V	1
C311	C1ETDM105A--	TANTAL 1M 25V	1	RC36	COJRE-107A--	ELECT 100M 6.3V	1
C312	C1HCDC330RH-	CERAMIC 33P RH 50V	1	RC37	C1EYDK223C--	CERAMIC 0.022M C 25V	1
C313	C1HYDK221W--	CERAMIC 220P W 50V	1	RC38	C1HCDC2R0RH-	CERAMIC 2P RH 50V	1
C314	C1EYDK473C--	CERAMIC 0.047M C 25V	1	RC39	C1EYDK103C--	CERAMIC 0.01M C 25V	1
C315	COJRE-107A--	ELECT 100M 6.3V	1	RC41	C1EYDK223C--	CERAMIC 0.022M C 25V	1
C316	C1CRE-106A--	ELECT 10M 16V	1	RC42	COJTD476A--	TANTAL 47M 6.3V	1
C317	C1EYDK222C--	CERAMIC 2200P C 25V	1	RC43	C1EYDK102C--	CERAMIC 1000P C 25V	1
C318	C1EYDK103C--	CERAMIC 0.01M C 25V	1	RC44	C1EYDK223C--	CERAMIC 0.022M C 25V	1
C319	COJRE-476A--	ELECT 47M 6.3V	1	RC45	C1HSEJ331A--	STYROL 330P 50V	1
C320	C1HFRK683A--	MYLAR 0.068M 50V	1	RC46	C1HCDC2R0RH-	CERAMIC 2P RH 50V	1
C321	COJRE-477A--	ELECT 470M 6.3V	1	RC47	C1EYDK103C--	CERAMIC 0.01M C 25V	1
C322	COJRE-107A--	ELECT 100M 6.3V	1	RC48	C1EYDK473C--	CERAMIC 0.047M C 25V	1
C323	C1EYDK473C--	CERAMIC 0.047M C 25V	1	RC49	C1ARE-106A--	ELECT 10M 10V	1
C324	COJTD476A--	TANTAL 47M 6.3V	1	RC50	C1EYDK223C--	CERAMIC 0.022M C 25V	1
				RC51	C1ARE-226A--	ELECT 22M 10V	1
				RC52	C1EYDK103C--	CERAMIC 0.01M C 25V	1

- NOTICE:**
1. Parts orders must contain Model Number, Parts Number and Description.
 2. Ordering quantity of resistors must be multiple of 10pcs.
 3. Component parts indicated by parentheses in the column Q'ty are not available.

PARTS LIST

Schematic Location	Parts No.	Description	Q'ty	Schematic Location	Parts No.	Description	Q'ty
RC53	C1ERE-476A--	ELECT 47M 25V	1	RR42	R2BSPJ104A	CARBON 100K 1/8WJ	1
RC54	C1EYDK103C--	CERAMIC 0.01M C 25V	1	RR43	R2BSPJ474A	CARBON 470K 1/8WJ	1
RC55	C1EYDK223C--	CERAMIC 0.022M C 25V	1	RT01	4 2561 08970	FM IF TRANS	1
RC56	C1HDIKK683C--	M-CERAMIC 0.068M 50V	1	RT02	4 2561 09070	FM IF TRANS	1
RC57	C1EYDK472C--	CERAMIC 4700P C 25V	1	RT03	4 2561 09170	FM IF TRANS	1
RC58	C1HYDP103Z--	CERAMIC 10000P Z 50V	1	RT04	4 2561 09270	AM OSC TRANS	1
RD01	4 2021 18770	SI DIODE MA56	1	RT05	4 2561 09370	AM IF TRANS	1
RD03	4 2021 20370	VARACTOR DI SVC201	1	RT06	4 2561 09470	AM IF TRANS	1
RD04	4 2021 07470	SI DIODE 1S2076	1	RT07	4 2561 09570	AM IF TRANS	1
RD05	4 2021 20370	VARACTOR DI SVC201	1	R301	R2BSPJ680A	CARBON 68 1/8WJ	1
RD06	4 2021 15370	VARACTOR DIODE 1S553	1	R302	R2BSPJ472A	CARBON 4.7K 1/8WJ	1
RD07	4 2021 15270	GE DIODE 1S188FM	1	R303	R2BSUJ223A	CARBON 22K 1/8WJ	1
RD08	4 2021 15270	GE DIODE 1S188FM	1	R304	R2BSPJ102A	CARBON 1K 1/8WJ	1
RD09	4 2021 20470	VARACTOR DI SVC303	1	R305	R2BSPJ822A	CARBON 8.2K 1/8WJ	1
RD10	4 2021 20470	VARACTOR DI SVC303	1	R306	R2BSPJ102A	CARBON 1K 1/8WJ	1
RD11	4 2021 15270	GE DIODE 1S188FM	1	R307	R2BSPJ151A	CARBON 150 1/8WJ	1
RD12	4 2021 20170	ZE DIODE RD10EB3	1	R309	R2BSUJ821A	CARBON 820 1/8WJ	1
RD13	4 2021 07470	SI DIODE 1S2076	1	R311	R2BSPJ123A	CARBON 12K 1/8WJ	1
RD14	4 2021 07470	SI DIODE 1S2076	1	R312	R2BSPJ472A	CARBON 4.7K 1/8WJ	1
RD15	4 2021 07470	SI DIODE 1S2076	1	R313	R2BSPJ472A	CARBON 4.7K 1/8WJ	1
RD19	4 2021 07470	SI DIODE 1S2076	1	R314	R2BSPJ472A	CARBON 4.7K 1/8WJ	1
RD20	4 2021 07470	SI DIODE 1S2076	1	R315	H2BSPJ472A	CARBON 4.7K 1/8WJ	1
RL01	4 2061 08970	IC-UPC1018C	1	R316	R2BSPJ472A	CARBON 4.7K 1/8WJ	1
RL02	4 2591 05070	FM RF COIL	1	R317	R2BSPJ472A	CARBON 4.7K 1/8WJ	1
RL03	4 2591 05270	FM TRAP COIL	1	SW01	4 2311 10370	SLIDE SWITCH	1
RL04	4 2581 04770	FM OSC COIL	1	T301	4 2561 94370	QUADRATURE COIL	1
RL05	4 2571 04870	BAR ANTENNA	1	VR301	4 2221 34870	12FRN10FB-10K	1
RL06	4 2721 00689	PEAKING COIL 68	1	X301	4 2531 10970	CERAMIC FILTER 4.5M	1
RQ01	TG2SC668--D--	SI TR 2SC668	1	X302	4 2531 11070	CERAMIC FILTER 5.5M	1
or	TG2SC668--E--	SI TR 2SC668	1	X303	4 2531 11170	CERAMIC FILTER 6.0M	1
RQ02	TG2SC668--D--	SI TR 2SC668	1	P1	111 0 9081 01014	1P MICRO SOCKET ASSY	1
or	TG2SC668--E--	SI TR 2SC668	1	P3	111 0 9081 01015	1P MICRO SOCKET ASSY	1
or	TT2SC2668----	SI TR 2SC2668	1	P5	111 0 9081 01016	1P MICRO SOCKET ASSY	1
RQ03	TG2SC930SP----	SI TR 2SC930SP	1	P6	111 0 9081 01017	1P MICRO SOCKET ASSY	1
or	TT2SC2669----	SI TR 2SC2669	1	P4	111 0 9081 01021	1P MICRO SOCKET ASSY	1
RQ04	TG2SC2210----	SI TR 2SC2210	1		111 0 9081 03036	3P M MICRO SOCKET AY	1
RR01	R2BSUJ472A	CARBON 4.7K 1/8WJ	1		111 9 1800 00750	SHIELD WIRE TMF-JPN	1
RR02	R2BSUJ154A	CARBON 150K 1/8WJ	1		111 2 6111 28270	RADIO SHLD PLATE-TMF	1
RR03	R2BSUJ393A	CARBON 39K 1/8WJ	1				
RR04	R2BSUJ102A	CARBON 1K 1/8WJ	1				
RR05	R2BSUJ221A	CARBON 220 1/8WJ	1				
RR06	R2BSUJ124A	CARBON 120K 1/8WJ	1				
RR07	R2BSUJ101A	CARBON 100 1/8WJ	1				
RR08	R2BSUJ223A	CARBON 22K 1/8WJ	1				
RR09	R2BSUJ223A	CARBON 22K 1/8WJ	1				
RR10	R2BSUJ152A	CARBON 1.5K 1/8WJ	1				
RR11	R2BSUJ101A	CARBON 100 1/8WJ	1				
RR12	R2BSUJ124A	CARBON 120K 1/8WJ	1				
RR13	R2BSUJ103A	CARBON 10K 1/8WJ	1				
RR14	R2BSUJ223A	CARBON 22K 1/8WJ	1				
RR15	R2BSUJ221A	CARBON 220 1/8WJ	1				
RR16	R2BSUJ182A	CARBON 1.8K 1/8WJ	1				
RR17	R2BSUJ334A	CARBON 330K 1/8WJ	1				
RR18	R2BSUJ471A	CARBON 470 1/8WJ	1				
RR19	R2BSUJ102A	CARBON 1K 1/8WJ	1				
RR20	R2BSUJ102A	CARBON 1K 1/8WJ	1				
RR21	R2BSUJ472A	CARBON 4.7K 1/8WJ	1				
RR22	R2BSUJ472A	CARBON 4.7K 1/8WJ	1				
RR23	R2BSUJ563A	CARBON 56K 1/8WJ	1				
RR24	R2BSUJ334A	CARBON 330K 1/8WJ	1				
RR25	R2BSUJ100A	CARBON 10 1/8WJ	1				
RR26	R2BSUJ470A	CARBON 47 1/8WJ	1				
RR27	R2BSUJ124A	CARBON 120K 1/8WJ	1				
RR28	R2BSUJ223A	CARBON 22K 1/8WJ	1				
RR29	R2BSUJ182A	CARBON 1.8K 1/8WJ	1				
RR30	R2BSUJ822A	CARBON 8.2K 1/8WJ	1				
RR31	R2BSUJ391A	CARBON 390 1/8WJ	1				
RR32	R2BSUJ124A	CARBON 120K 1/8WJ	1				
RR33	R2BSUJ103A	CARBON 10K 1/8WJ	1				
RR35	R2BSUJ562A	CARBON 5.6K 1/8WJ	1				
RR36	R2BSUJ273A	CARBON 27K 1/8WJ	1				
RR37	R2BSUJ222A	CARBON 2.2K 1/8WJ	1				
RR38	R2BSUJ472A	CARBON 4.7K 1/8WJ	1				
RR39	R2BSPJ102A	CARBON 1K 1/8WJ	1				
RR40	R2BSPJ105A	CARBON 1M 1/8WJ	1				
RR41	R2BSPJ274A	CARBON 270K 1/8WJ	1				

- NOTICE:**
1. Parts orders must contain Model Number, Parts Number and Description.
 2. Ordering quantity of resistors must be multiple of 10pcs.
 3. Component parts indicated by parentheses in the column Q'ty are not available.

CIRCUIT BOARD DIAGRAM (RADIO)

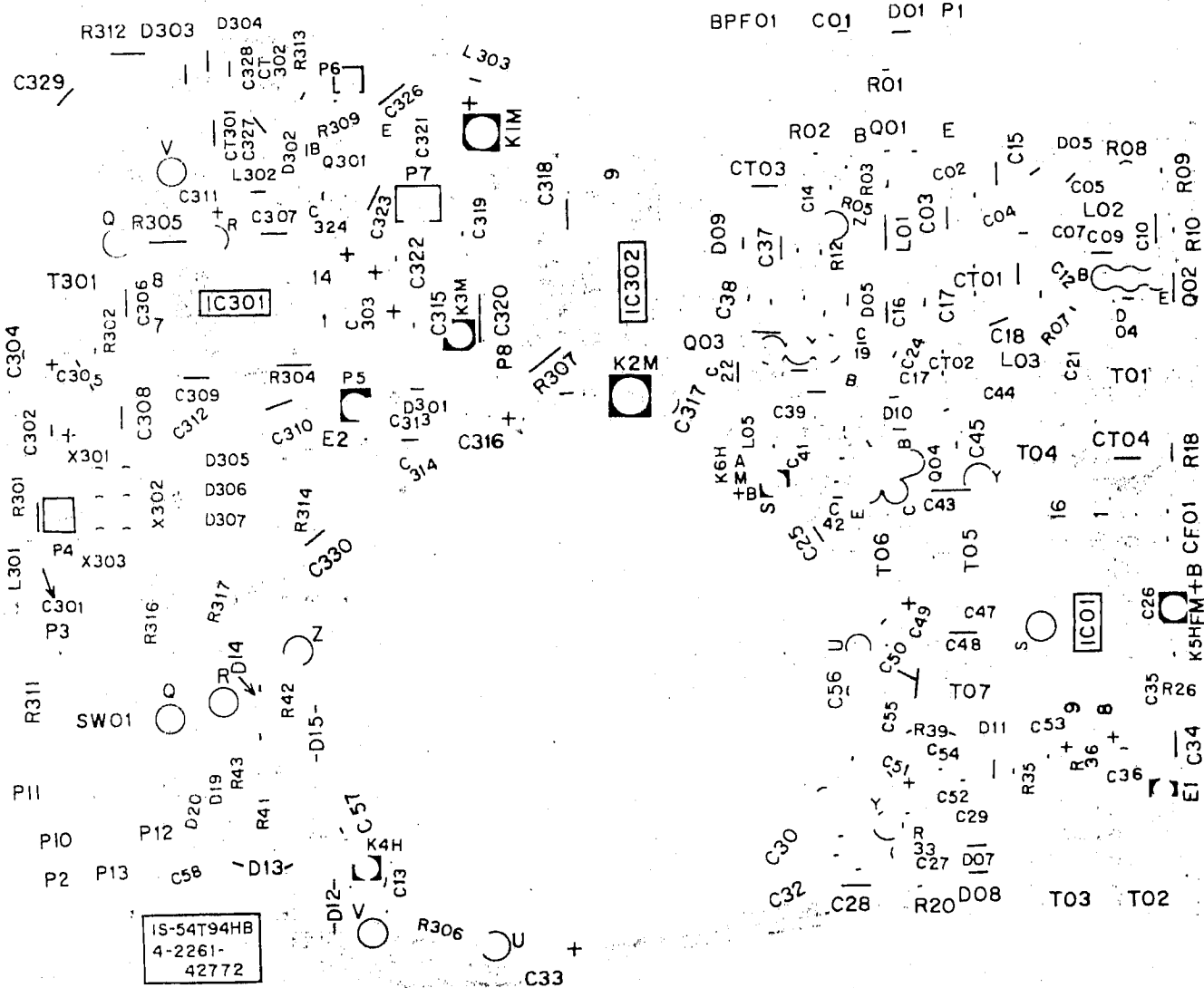

OSC BLOCK P.C.B.

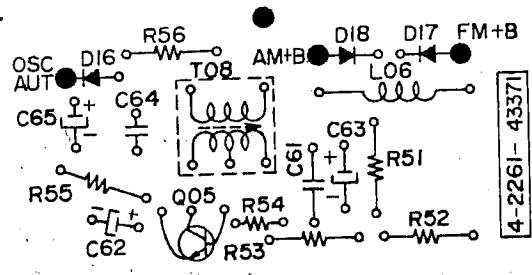

CIRCUIT BOARD DIAGRAM (RADIO)

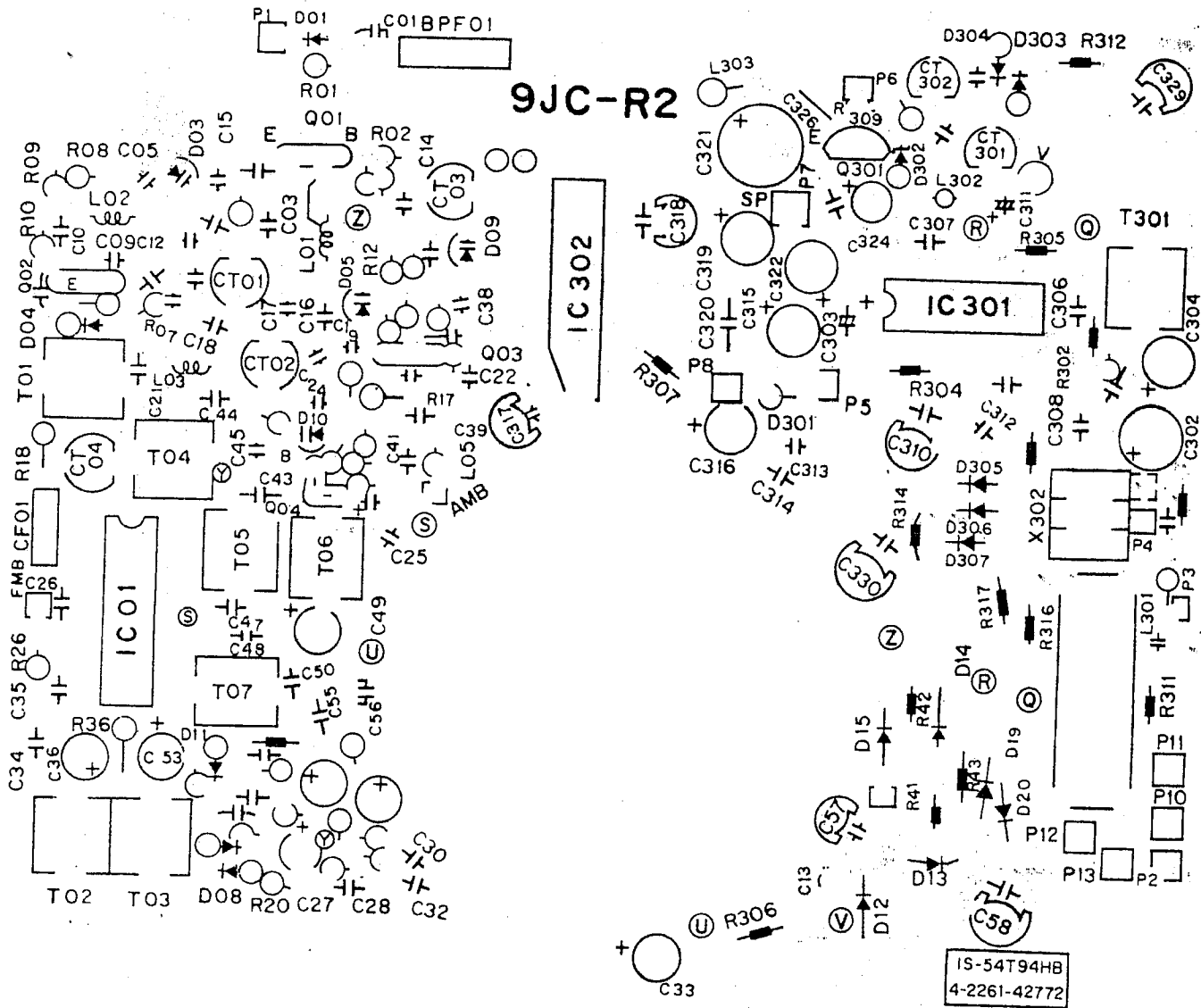

OSC BLOCK P.C.B.

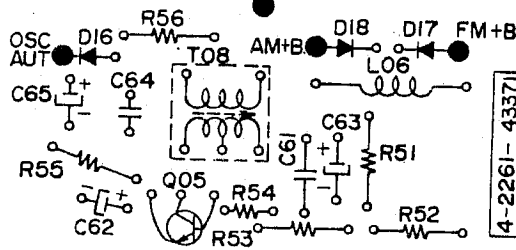

SCHEMATIC DIAGRAM (RADIO)

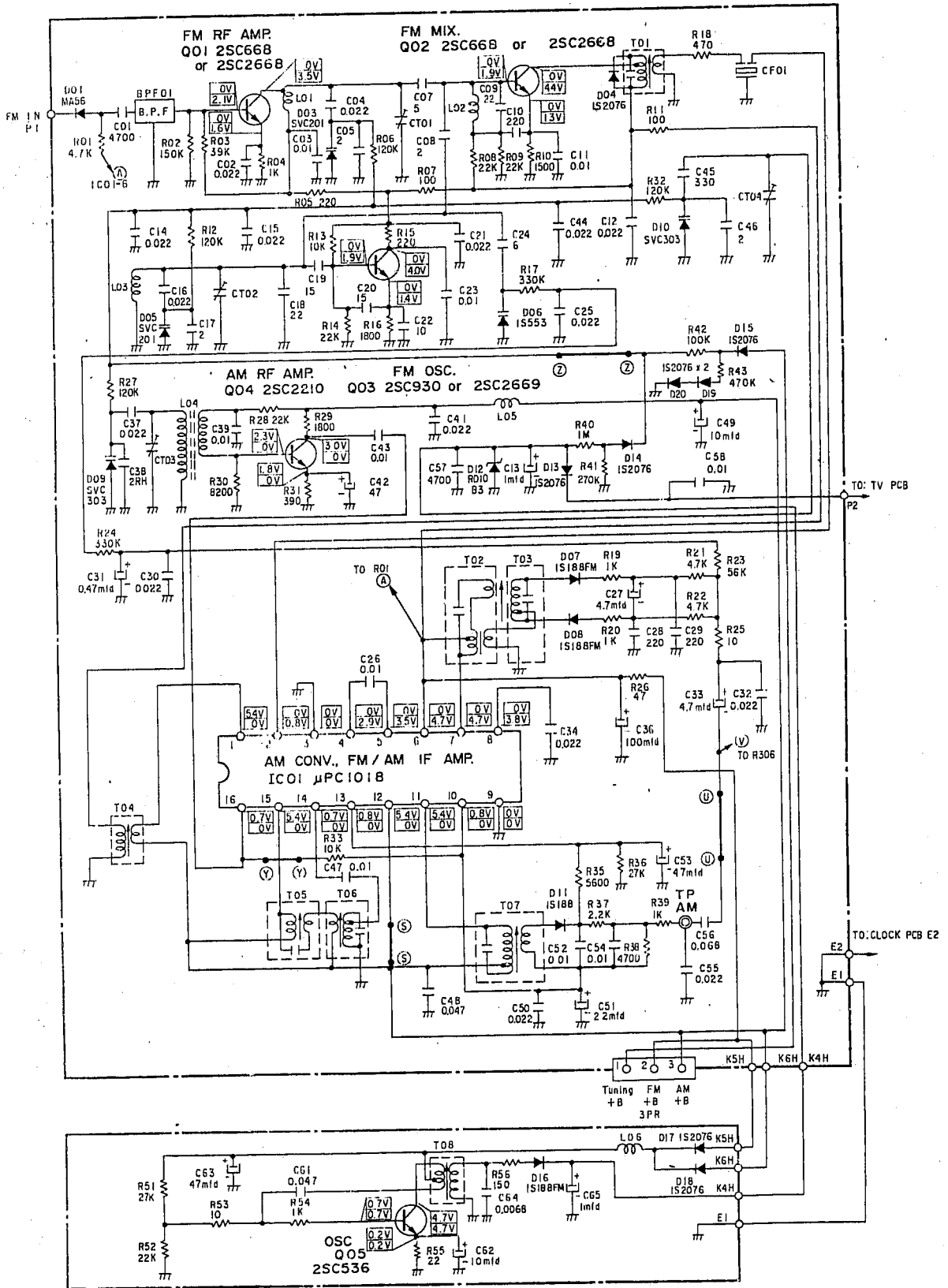

NOTE

- AM voltage reading
- FM voltage reading

CIRCUIT BOARD DIAGRAM (CLOCK CONTROL)

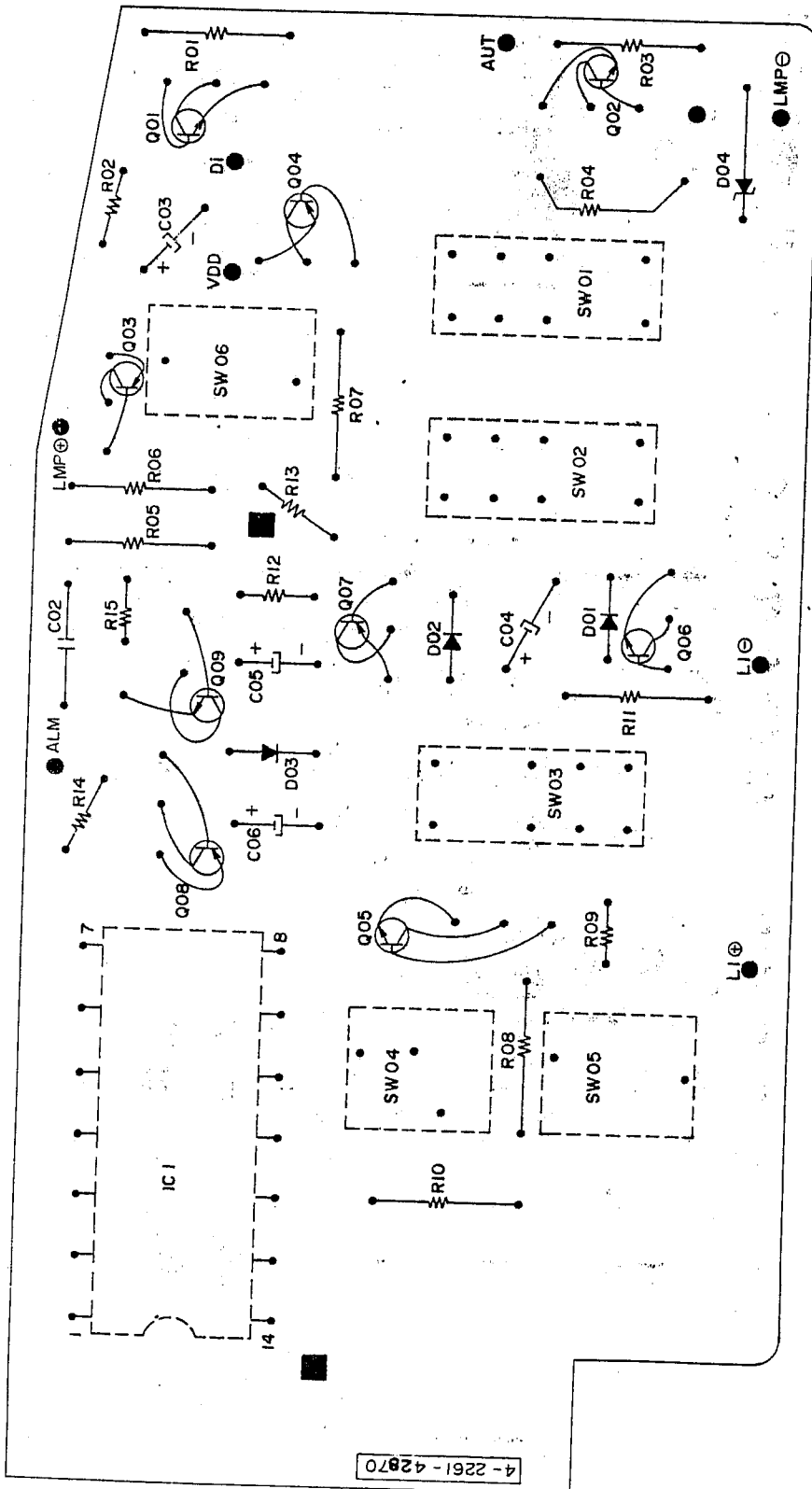

SCHEMATIC DIAGRAM (CLOCK)

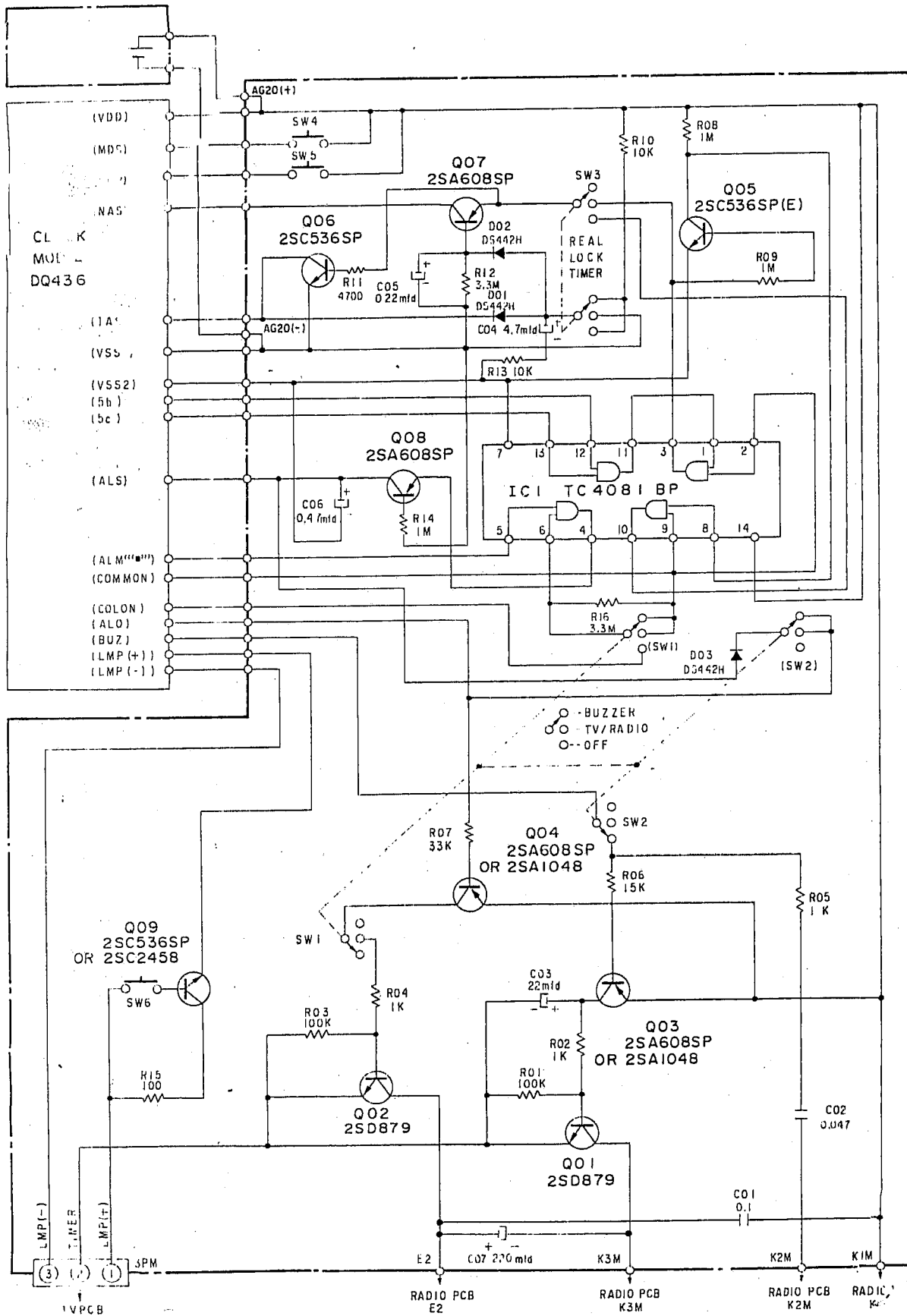

CIRCUIT BOARD DIAGRAM (TV)

