

Service Manual

TV / VCR Combination

CHASSIS : CP-062

MODEL : DVT-14/20H1(T)F DVT-14/20H2(T)F
 DVT-14/20H1(T)P DVT-14/20H2(T)P
 DVT-14/20H1(T)D DVT-14/20H2(T)D
 DVT-14H2(T)FG/(T)PG DVT-14H2(T)FB/(T)PB



SPECIFICATIONS

ITEMS	MODEL	DVT-14/20H1(T)F, DVT-14/20H2(T)F, DVT-14/20H1(T)P, DVT-14/20H2(T)P, DVT-14/20H1(T)D, DVT-14/20H2(T)D, DVT-14H2(T)FG/(T)PG, DVT-14H2(T)FB/(T)PB	REMARK
TV SECTION	STANDARD	PAL-B/G(F MODEL), PAL-I/II(P MODEL), PAL/SECAM-B/G, D/K (D MODEL)	
	SCREEN SIZE	14": A34JLL90X01, A34AGT13X, A33LPE02X01, A34EAC01X06, 20": A48JLL90X01, A48LPE01X01, A48EAX33X01	
	MAIN VOLTAGE	220V~240V AC, 50Hz	
	POWER CONSUMPTION	STAND BY MODE : BELOW 5 Watts OPERATION MODE : 14" = 59Watts, 20" = 65Watts	
	SOUND OUTPUT	1Wmin(14"), 1.2 Wmin(20")(at 60% mod., 10% THD)	
	SPEAKER	3Watts 8 Ohm	
	ANTENNA IMPEDANCE	75 Ohm unbalanced input	
	TUNING SYSTEM	FVS(FREQUENCY SYNTHESIS) TUNING	
	TUNER	VHF-L: E2-S7, VHF-H:S8-S36, UHF:S37-E69(PAL-I = UHF ONLY)	
	NUMBER OF PROGRAM	70 PROGRAM	
	AUX. TERMINAL	SCART JACK (REAR)	
	REMOTE CONTROLLER	R-46C with 2 "AAA" type batteries	
	OTHER FEATURE	ON SCREEN DISPLAY, SLEEP TIMER, WAKE UP TIMER FULL AUTO SEARCH, MANUAL/FINE TUNING CHILD LOCK, AUTO REPEAT PICTURE TYPE SELECTION(NORMAL 1/2, FAVOURITE) INDEX SEARCH, TV/AV	
VIDEO SECTION	SINGLE SYSTEM	PAL/SECAM colour and CCIR mono chrome signals, 625lines/50fields.	
	RECORDING SYSTEM	Rotary 2-Head herical Scan with a slant double azimuth combination video head	
	INPUT	1Vp-p, 75 ohms, unbalanced	
	OUTPUT	1Vp-p, 75 ohms, unbalanced	
	SIGNAL TO NOISE RATIO	45dB with NETTETE IMAGE control at center position.	
	HORIZONTAL RESOLUTION	240lines with NETTETE IMAGE control at center posion	
AUDIO	RECORDING SYSTEM	LONGITUDINAL TRACK	
	INPUT	-3.8dBm(500m Vrms), more than 47 Kohms, unbalanced	
	OUTPUT	-3.8dBm(500mVrms), less than 1Kohm, unbalanced	
	FREQUENCY RANGE	100Hz to 8KHZ	
	SIGNAL TO NOISE RADIO	40dB(more than)	
GENERAL	TEMPERATRE	5°C to 35°C(operating), -20°C to 60° C(storage temperature)	
	FORMAT	standard	
	TAPE WIDTH	12.65mm	
	TAPE SPEED	SP : 23.39mm/sec, LP : 11.70mm/sec	
	MAX. RECORDING TIME	SP :240min. win E-240 video cassette	
	WITH FULLSIZE CASSETTE	LP :480min. with E-240 video cassette	

✓ Caution

: In this Manual, some parts can be changed for improving, their performance without notice in the parts list. So, if you need the latest parts information, please refer to PPL(Parts Price List) in Service Information Center (<http://svc.dwe.co.kr>).

TABLE OF CONTENTS

SAFETY INSTRUCTION	2
SPECIFICATION	3
CIRCUIT BLOCK DIAGRAM	4
ALIGNMENT INSTRUCTIONS.....	5
SERVICE REMOCON DIAGRAM	8
SCHEMATIC DIAGRAM	11
EXPLODED VIEW	13
PRINTED CIRCUIT BOARD.....	15
SERVICE PARTS LIST	16
Different parts list for size	27
The different parts list for system	29

APPENDIX (Appendix is provided only by internet [<http://svc.dwe.co.kr>])

CIRCUIT DESCRIPTION	1
---------------------------	---

SAFETY INSTRUCTION

WARNING : BEFORE SERVICING THIS CHASSIS, READ THE "X-RAY RADIATION PRECAUTION", "SAFETY PRECAUTION" AND "PRODUCTION SAFETY NOTICE" BELOW.

X-RAY RADIATION PRECAUTION

1. Excessive high voltage can produce potentially hazardous X-RAY RADIATION. To avoid such hazards, the high voltage must not exceed the specified limit. The nominal value of the high voltage of this receiver is 23-25KV(14"),25-28KV(20") at max. beam current. The high voltage must not, under any circumstances, exceed 26KV (14"),30KV (20"). Each time a receiver requires servicing, the high voltage should be checked. It is recommended the reading of the high voltage be recorded as a part of the service records, It is important to use an accurate and reliable high voltage meter.
2. The only source of X-RAY radiation in this TV receiver is the picture tube. For continuous X-RAY RADIATION protection, the replacement tube must be exactly the same type tube as specified in the parts list.

SAFETY PRECAUTION

1. Potentials of high voltage are present when this receiver is operating. Operation of the receiver outside the cabinet or with the back board removed involves a shock hazard from the receiver.
 - 1) Servicing should not be attempted by anyone who is not thoroughly familiar with the precautions necessary when working on high voltage equipment.
 - 2) Always discharge the picture tube before handling the tube. The picture tube is highly evacuated and if broken, glass fragments will be violently expelled.
2. If any fuse in this TV receiver is blown, replace it with the FUSE specified in the Replacement Parts list.
3. When replacing a high wattage resistor (metal oxide film resistor) in circuit board, keep the resistor 10mm away from circuit board.
4. Keep wires away from high voltage or high temperature components.
5. This receiver must operate under AC260 volts, 50Hz. NEVER connect to DC supply or any other power or frequency.

PRODUCT SAFETY NOTICE

Many electrical and mechanical parts in this have special safety-related characteristics.

These characteristics are often passed unnoticed by a visual inspection and the X-RAY RADIATION protection afforded by them cannot necessarily be obtained by using replacement components rated for higher voltage, wattage, etc. Replacement parts which have these special safety characteristics are identified in this manual and its supplements, electrical components having such features are identified by designated symbol on the parts list.

Before replacing any of these components, read the parts list in this manual carefully.

The use of substitute replacement parts which do not have the same safety characteristics as specified in the parts list may create X-RAY Radiation.

SPECIFICATION

ITEMS		MODEL	DVT-14/20H1(T)F, DVT-14/20H2(T)F, DVT-14/20H1(T)P, DVT-14/20H2(T)P, DVT-14/20H1(T)D, DVT-14/20H2(T)D, DVT-14H2(T)FG(T)PG, DVT-14H2(T)FB(T)PB	REMARK
TV SECTION	STANDARD		PAL-B/G(F MODEL) PAL-I/II(P MODEL) PAL/SECAM-B/G, D/K (D MODEL)	
	SCREEN SIZE		14": A34JLL90X01, A34AGT13X, A33LPE02X01, A34EAC01X06 20": A48JLL90X01, A48LPE01X01, A48EAX33X01	
	MAIN VOLTAGE		220V-240V AC, 50Hz	
	POWER CONSUMPTION		STAND BY MODE : BELOW 5 Watts OPERATION MODE : 14" = 59Watts, 20" = 65Watts	
	SOUND OUTPUT		1Wmin(14"), 1.2 Wmin(20")(at 60% mod., 10% THD)	
	SPEAKER		3Watts 8 Ohm	
	ANTENNA IMPEDANCE		75 Ohm unbalanced input	
	TUNING SYSTEM		FVS(FREQUENCY SYNTHESIS) TUNING	
	TUNER		VHF-L: E2-S7 VHF-H:S8-S36 UHF:S37-E69(PAL-I = UHF ONLY)	
	NUMBER OF PROGRAM		70 PROGRAM	
	AUX. TERMINAL		SCART JACK (REAR)	
	REMOTE CONTROLLER		R-46C with 2 "AAA" type batteries	
	OTHER FEATURE		ON SCREEN DISPLAY, SLEEP TIMER, WAKE UP TIMER FULL AUTO SEARCH, MANUAL/FINE TUNING CHILD LOCK AUTO REPEAT PICTURE TYPE SELECTION(NORMAL 1/2, FAVOURITE) INDEX SEARCH, TV/AV	
VIDEO SECTION	SINGLE SYSTEM		PAL/SECAM colour and CCIR mono chrome signals, 625lines/50fields.	
	RECORDING SYSTEM		Rotary 2-Head herical Scan with a slant double azimuth combination video head	
	INPUT		1Vp-p, 75 ohms, unbalanced	
	OUTPUT		1Vp-p, 75 ohms, unbalanced	
	SIGNAL TO NOISE RATIO		45dB with NETTETE IMAGE control at center position.	
	HORIZONTAL RESOLUTION		240lines with NETTETE IMAGE control at center posion	
AUDIO	RECORDING SYSTEM		LONGITUDINAL TRACK	
	INPUT		-3.8dBm(500m Vrms), more than 47 Kohms, unbalanced	
	OUTPUT		-3.8dBm(500mVrms), less than 1Kohm, unbalanced	
	FREQUENCY RANGE		100Hz to 8KHZ	
	SIGNAL TO NOISE RADIO		40dB(more than)	
GENERAL	TEMPERATRE		5°C to 35°C(operating) -20°C to 60°C(storage temperature)	
	FORMAT		standard	
	TAPE WIDTH		12.65mm	
	TAPE SPEED		SP : 23.39mm/sec LP : 11.70mm/sec	
	MAX. RECORDING TIME WITH FULLSIZE CASSETTE		SP :240min. win E-240 video cassette LP :480min. with E-240 video cassette	

NOTE

Design and specifications can be subjected to change without notice.

CIRCUIT BLOCK DIAGRAM

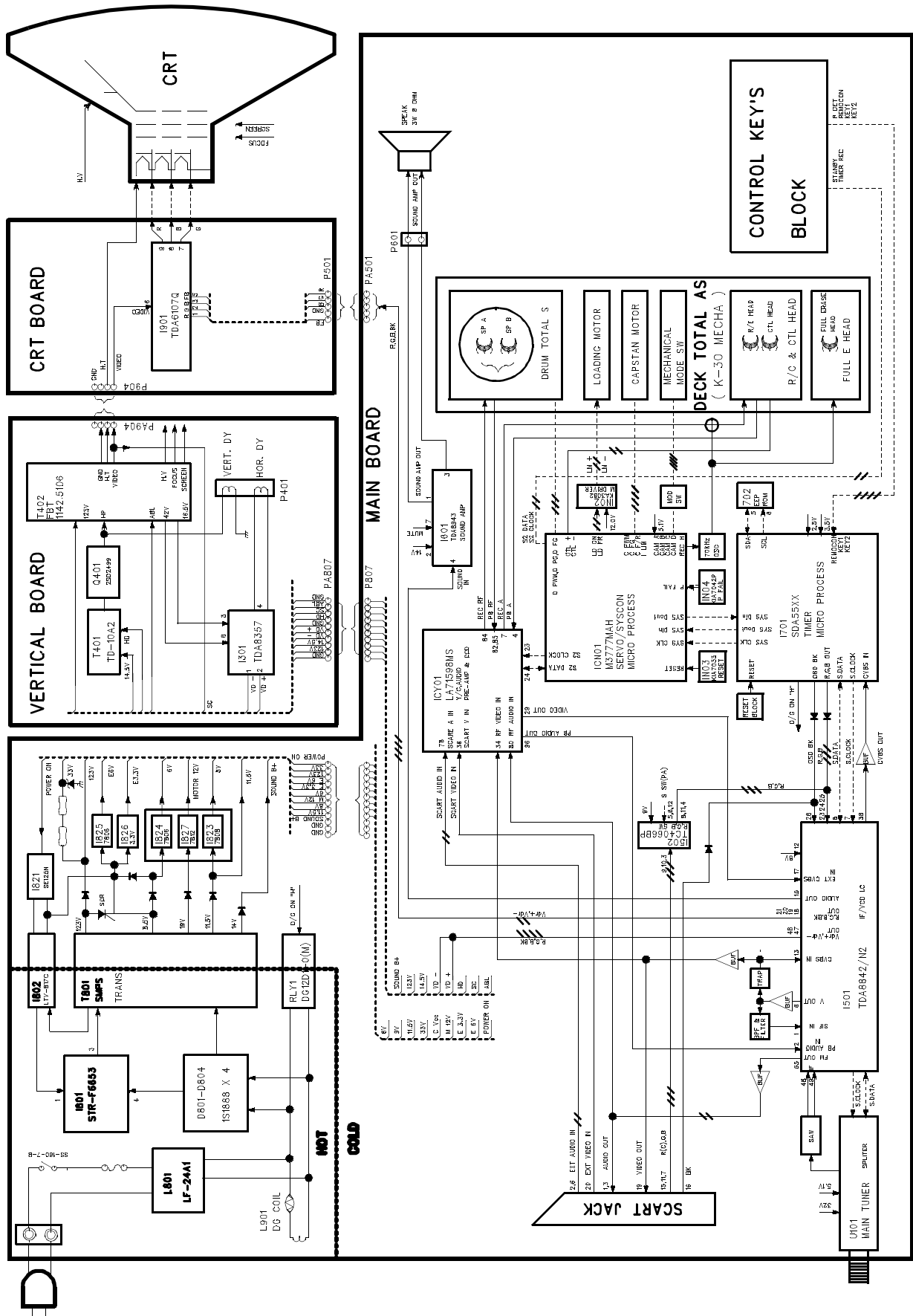

ALIGNMENT INSTRUCTIONS

1. MAIN TUNER AGC

- 1) Set a Pattern Generator with RF level 62 ± 2 dBuV, 210.25 MHz.
- 2) Connect a OSCILLOSCOPE PROBE to P101 (TUNER AGC INPUT).
- 3) Adjust AGC UP/DOWN KEY the voltage drop about 1V DC over below its maximum voltage.

2. SCREEN

- 1) Apply a COLOR BAR PATTERN SIGNAL.
 - 2) Press the "SCREEN" KEY .
 - 3) Connect a OSCILLOSCOPE PROBE to P901 (CRT CATHODE R,G,B)
 - 4) Adjust the screen volume on FBT such that the highest black level voltage $120V \pm 5Vdc$.
- * Another methode
- 1) Press "AV Key" in condition of AV no signal.
 - 2) Press the "SCREEN" KEY .
 - 3) Connect a OSCILLOSCOPE PROBE to P901 (CRT CATHODE R,G,B)
 - 4) Adjust the screen volume on FBT such that the highest black level voltage $140 V \pm 5Vdc$.

3. WHITE BALANCE

- 1) Apply a COLOR BAR PATTERN SIGNAL.
- 2) Adjust the R,G,B UP/DOWN KEY of the other color which did not appear on the screen to obtain WHITE.

4. FOCUS

- 1) Apply a RETMA PATTERN SIGNAL.
- 2) Adjust the FOCUS VOLUME on FBT to obtain optimal resolution.

5. GEOMETRY

5.1 S-CORRECTION

- 1) Apply a CROSSHATCH PATTERN SIGNAL.
- 2) Adjust the S-CORR UP/DOWN KEY obtain the same distance between horizontal lines.

5.2 VERTICAL SLOPE

- 1) Apply a RETMA PATTERN SIGNAL.
- 2) Pressing the V-SLOPE +/- KEY, the lower half of the screen is blanked.
- 3) Adjust the border line of blanked picture coincident with the center marks of the patte using the V-SLOPE +/- KEY.

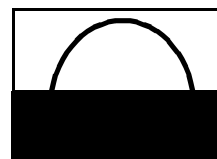

5.3 VERTICAL CENTER

- 1) Apply a RETMA PATTERN SIGNAL.
- 2) Adjust the center line of pattern coincident with the mechanical center marks of the CRT using the V-CENTER +/- KEY.

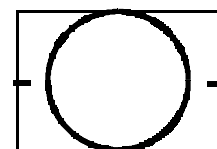

5.4 VERTICAL SIZE

- * The V-CENTER adjustment has to be done in advance.
- 1) Apply a RETMA PATTERN SIGNAL.
 - 2) Adjust the uppertime of the pattern coincident with the mechanical center marks of the CRT using the V-SIZE +/- KEY.

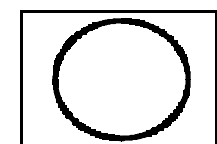

5.5 HORIZONTAL CENTER

- 1) Apply a RETMA PATTERN SIGNAL.
- 2) Adjust picture centering with H-CENTER +/- KEY.

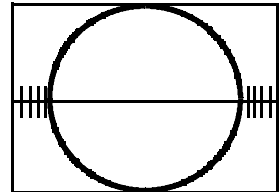

6. DECK ADJUSTMENT

6-1. X-POSITION AND P2,P3 ADJUSTMENT

1) Adjust point : X-POSITION

Checking point : oscilloscope ch1 = H/SW (PY03 #2)

oscilloscope ch2 = PB ENVE (PY03 #4)

Triggering : CH1

Measuring Equipment : oscilloscope, path jig

Mode : PLAYBACK, ATK OFF

Test tape : DP-2 (6KHz)

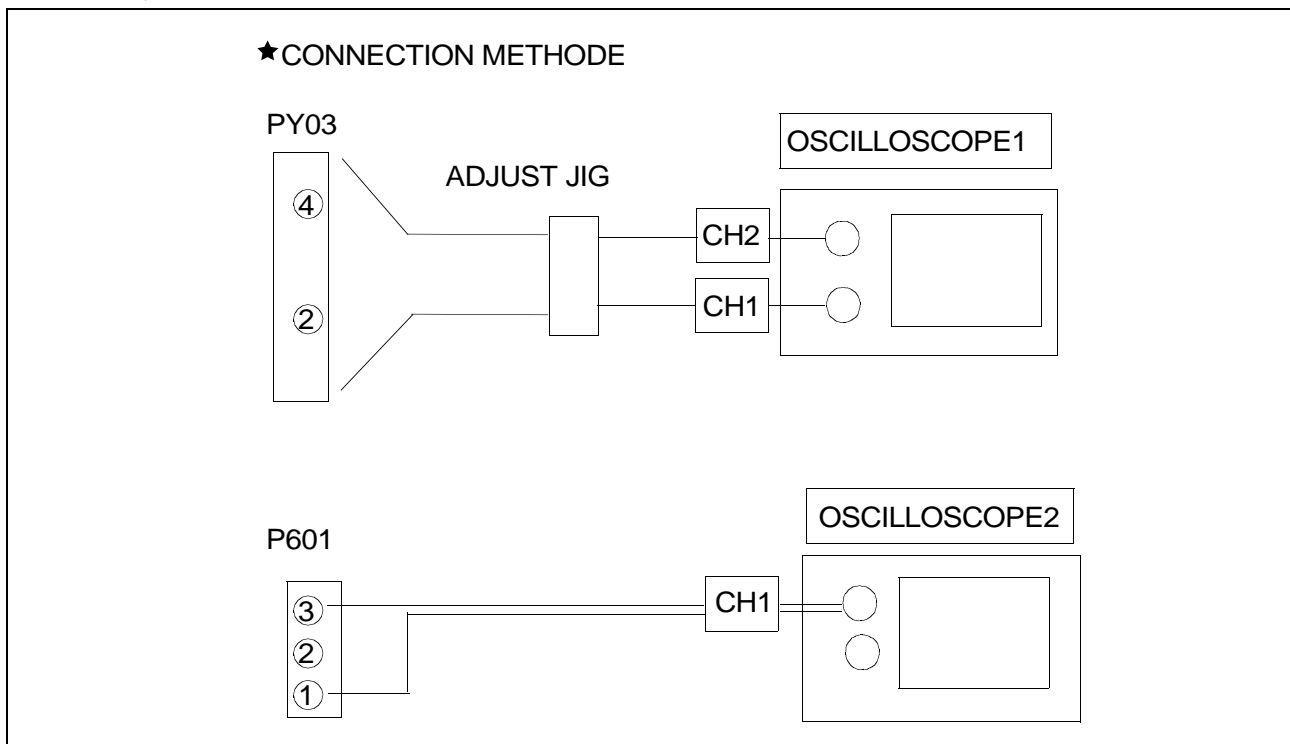

* Adjustment Procedure

- 1) Connect the PATH JIG to PY03 after Test tape PLAYBACK
- 2) Insert the DP-2 TAPE. (Auto playback)
- 3) Pressing the "ATK OFF" KEY.
- 4) Adjust the waveform of PB ENVE to maximum (figure 1) using X-position VR.
- 5) Adjust IN/OUTPUT GUIDE until the exact waveform appear as bellow figure 2.



max.
(figure 1)

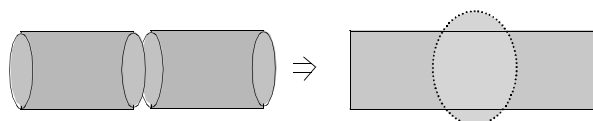

(figure 2)

ALIGNMENT INSTRUCTIONS

6-2. AUTO PG ADJUSTMENT

- 1) After adjustment of 6-1. Press the " REC." button.
- 2) Eject the Test tape.

6-3. AZIMUTH ADJUSTMENT

- 1) Adjust point : AZIMUTH SCREW

Checking point : SOUND OUTPUT (P601)

Measuring Equipment : oscilloscope or audio level meter.

Mode : PLAYBACK

Test tape : DP-2 (6KHz)

* Adjustment Procedure

- 1) Connect the measuring equipment to the AUDIO OUTPUT (P601) terminal.
- 2) After test tape playback, adjust the output level maximally by varying the azimuth screw.
- 3) Fix the azimuth screw with locking paint.

* If EEPROM (I702) has been changed :

- Option data has to be changed and
- all alignment function has to be readjusted.

SERVICE REMOCON

1. DIAGRAM

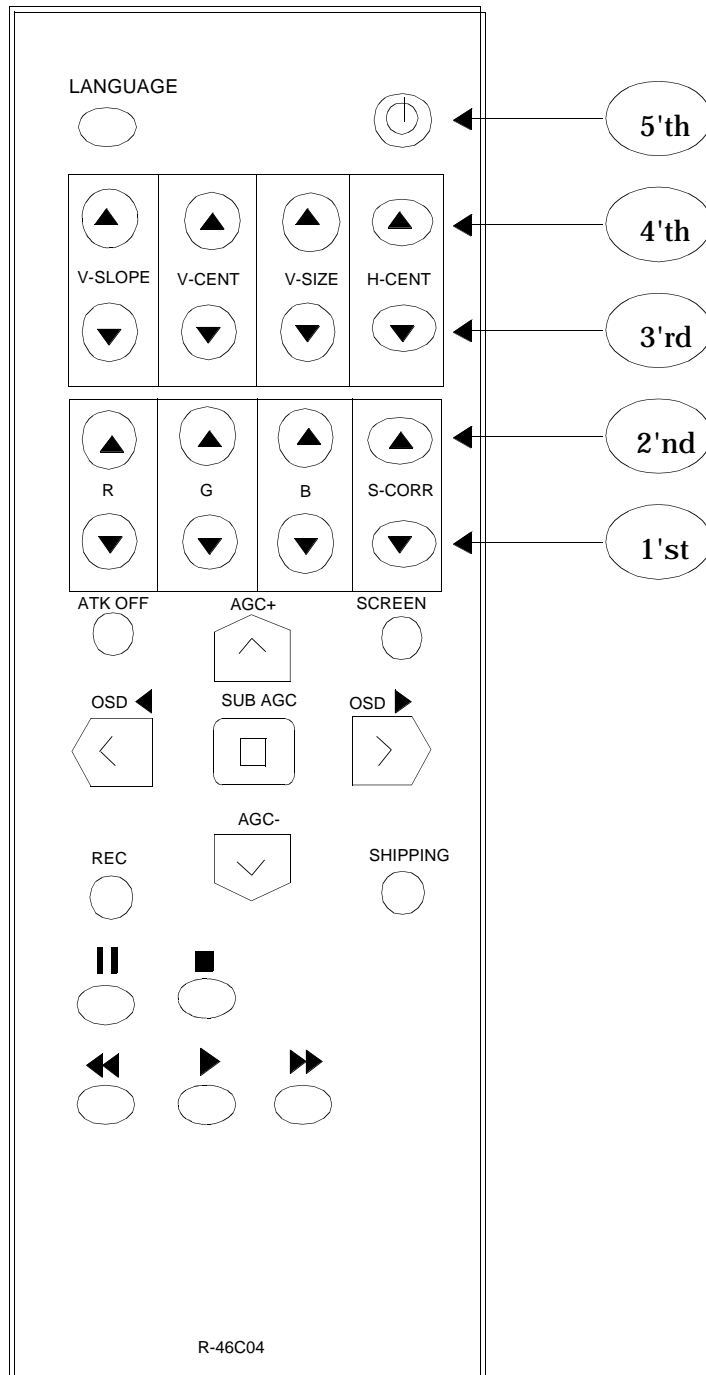

★ To enter the "SERVICE MODE"
 Press NORMAL-> AV->SLEEP->CLEAR->POWER buttons in regular sequency
 within 10seconds using USER REMOCON after setting ST-BY.

2. HOW TO CHECK TV SECTION WITHOUT VCR DECK

If you want to check TV section without DECK mechanism, then please perform in this order.

1. Pull out the power cord.
2. Remove the VCR DECK mechanism.
3. Supply the main power. (Main sw on)
4. Wait for about 10 seconds. (You can see the light of power LED if the TV is normal.
5. Turn on the TV using the remocon. (You can see the OSD "EMERGENCY")
6. Check the TV section.

3. Refer to general adjustment

1. S-CORR +/- (S-CORRECTION)

Press this button to adjust the same distance between horizontal lines on screen of crosshatch pattern.

2. V-SLOPE +/- (VERTICAL SLOPE)

Press this button to adjust the border line of blanked picture coincident with the center marks of the pattern.

3. V-CENT +/- (VERTICAL CENTER)

Press this button to adjust the center line of the pattern coincident with the mechanical center marks of the CRT on screen of RETMA pattern.

4. V-SIZE +/- (VERTICAL SIZE)

Press this button to adjust the upperside of the pattern coincident with the mechanical center marks the CRT on screen of RETMA pattern.

5. H-CENT +/- (HORIZONTAL CENTER)

Press this button to adjust picture centering with H-center on screen of RETMA pattern.

6. R,G,B +/- (WHITE BALANCE)

The screen is become WHITE adjust R,G,B level by this button.

7. ATK OFF (Auto tracking off)

Press this button to adjust X-Position adjustment.

Front panel's LED's are lighted up if you press this button.

Press the PB button.

ATK OFF: ●● (RED, RED)

ATK MAX : ●● (BLINK, OFF)

ATK MIN : ○● (OFF, BLINK)

ATK ON : ●● (BLINK,BLINK) ; LEFT LED = ST-BY, RIGHT LED = REC/T.REC"

8. REC

Press this button to adjust AUTO PG.

9. SCREEN

Press this button to adjust the screen volume on FBT.

10. SHIP (SHIPPING CONDITIONS)

Press this button to set the SHIPPING CONDITIONS.

11. SUB AGC (Only 2-TUNER Model)

Press this button to adjust SUB TUNER AGC.

Press once : picture is displayed colour pattern.

Press once more : picture is displayed black/white pattern.

12. AGC +/-

Press this button to adjust MAIN TUNER AGC.

SERVICE REMOCON

13. STILL

Press this button to enter the PAUSE/STILL mode.

14. STOP

Press this button to enter the STOP mode.

15. REW/REV

Press this button to enter the REW/REV mode.

16. PLAYBACK

Press this button to enter the PLAYBACK mode.

17. FF/CUE

Press this button to enter the FF/CUE mode.

18. LANGUAGE

Press this button to enter the LANGUAGE SELECTION mode.

You can select the language by AGC+(moving up) and AGC-(moving down) buttons.

19. OSD ◀ ▶

Press this button to adjust the OSD H-Position.

* If you forget your " child lock secret No. "

-> 1. Enter the SERVICE MODE.

2. POWER OFF/ON

SCHEMATIC DIAGRAM

CP-062 CHASSIS MAIN SCHEMATIC DIAGRAM

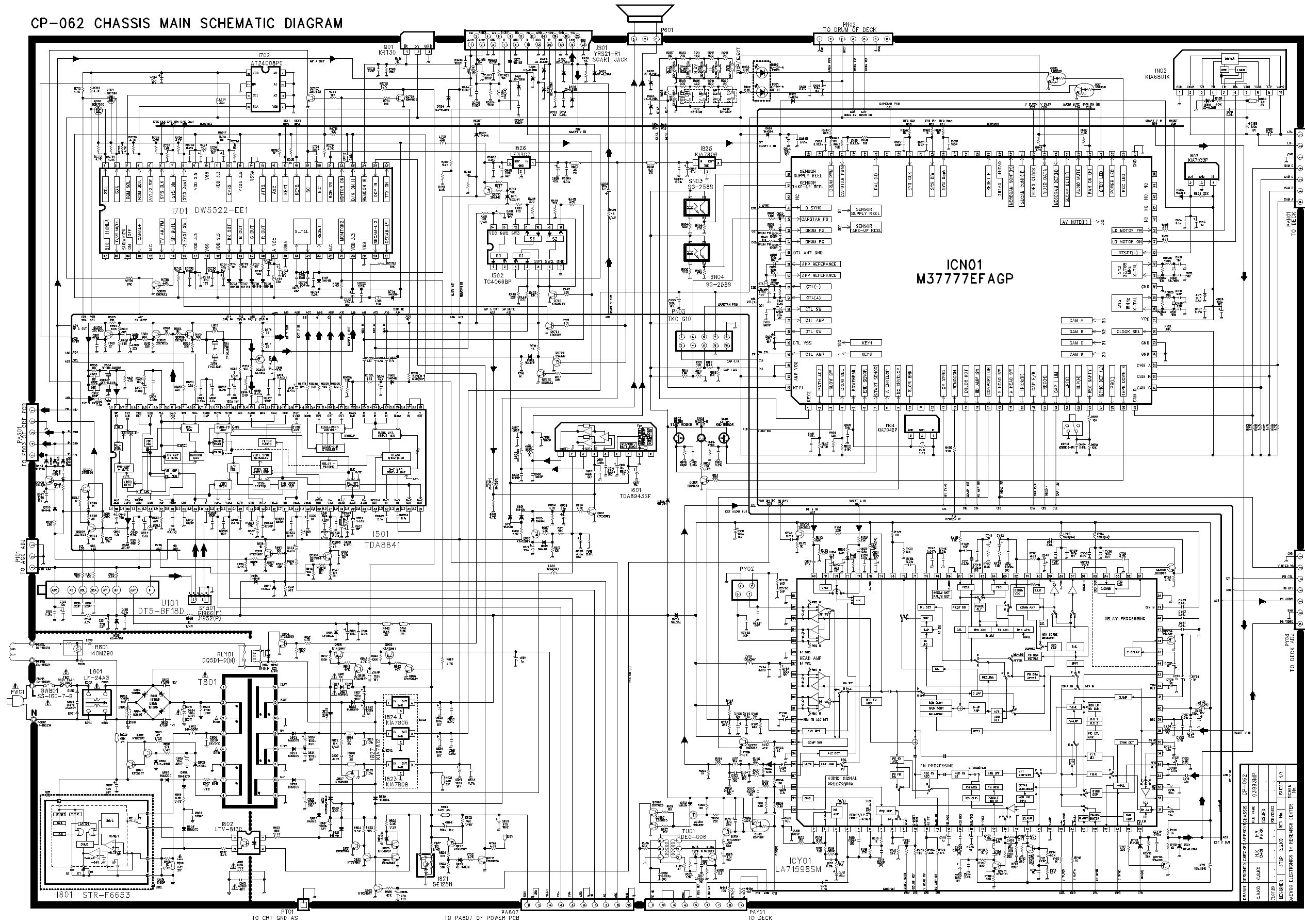

DIFFERENT PARTS FOR SIZE

NO	LOC	PART	14"	20"	NO	LOC	PART	14"	20"
1	C41B	C MYLAR	200V 0.62MF	200V 0.51MF	17				
2	C42E	C MYLAR	1.6KV 7200PF	1.6KV 6900PF	18				
3	L401	COIL H-LINEARITY	L-125(N.C)	L-102(N.C)	19				
4	R401	R H-OXIDE FILM	1W 2.0	1W 3.0	20				
5	R52S	R CARBON FILM	1/6W 8.2K	1/6W 5.6K	21				
6	R57S	R CARBON FILM	1/6W 5.6K	1/6W 18K	22				
7	P4E01	CONNECTOR	3PIN 300MM	3PIN 600MM	23				
8	VD1	COL DY	DDY-MH401	DDY-M2002	24				
9	V901	CRT BARE	A34JLL90X	A48JLL90X(W)	25				
10	ZZ131	CRT GROUND NET	1401S-101S-1P	2001H-101S-1P	26				
11	ZZ132	COIL DEGAUSSING	DC-1480	DC-205F	27				
12					28				
13					29				
14					30				
15					31				
16					32				

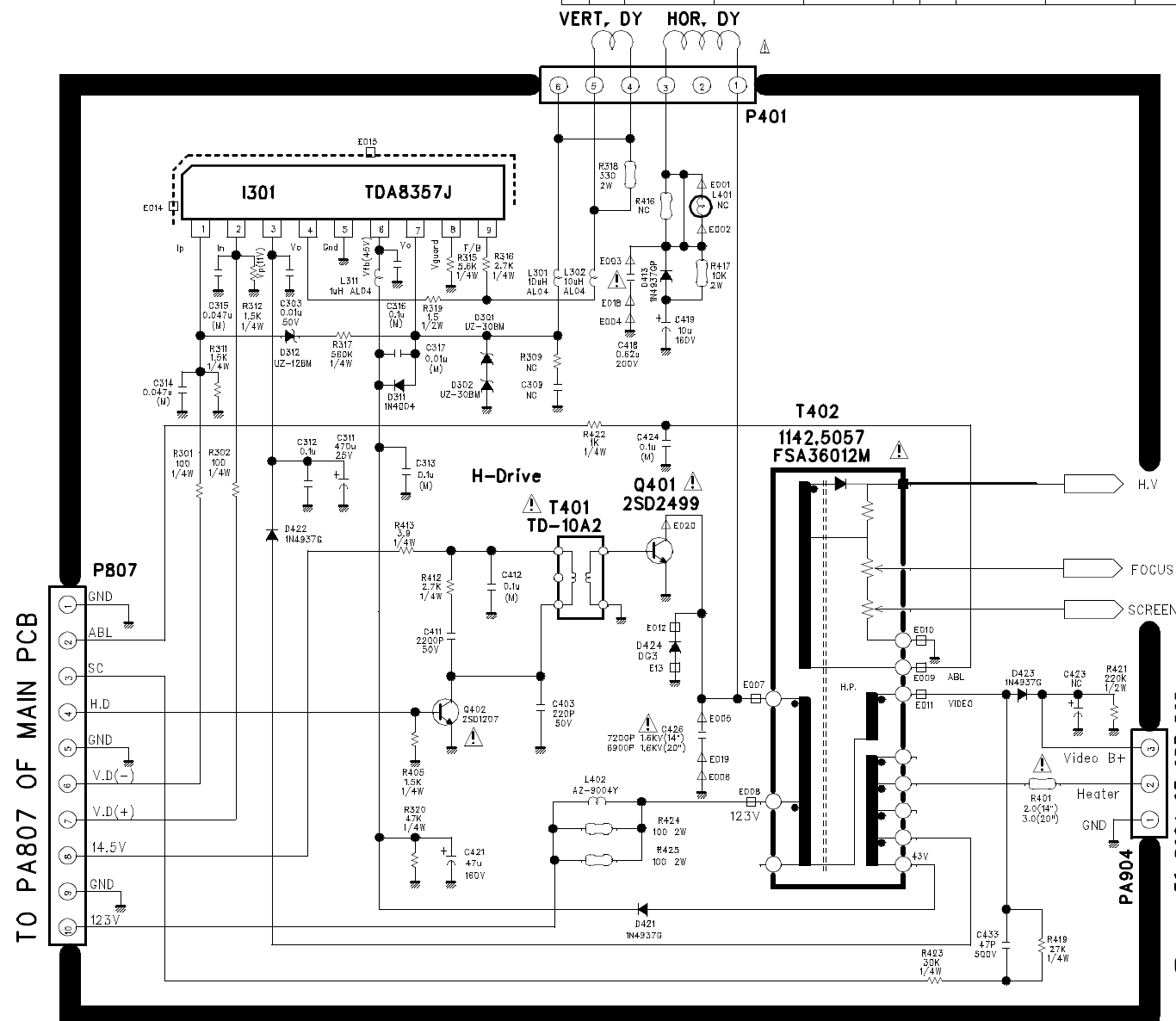

SAFETY CAUTION :
 BEFORE SERVICING THIS CHASSIS IT IS IMPORTANT THAT THE SERVICE TECHNICIAN READ AND FOLLOW THE "X-RAY RADIATION PRECAUTION. "SAFETY PRECAUTIONS" AND "PRODUCT SAFETY NOTICE" IN THE SERVICE MANUAL.

PRODUCT SAFETY NOTE :
 COMPONENTS MARKED WITH ⚠ ARE IMPORTANT FOR MAINTAINING THE SAFETY OF THE SET AND SHOULD BE REPLACED ONLY WITH TYPES IDENTICAL TO THOSE IN THE ORIGINAL OR SPECIFIED ONE IN THE PARTS LIST.
 DON'T DEGRADE THE SAFETY OF THE SET THROUGH IMPROPER SERVICING.

DRAWN	DESIGNED	CHECKED	APPROVED	CHASSIS	CP-062
C.S.KO	C.S.KO	H.K CHOI	H.R PARK	FILE NAME	13211MP
00.07.20				ISSUED	
				REVISED	
DESIGNER	3T2P	C.S.KO	REV No.	SHEET	1/1
DAEWOO ELECTRONICS TV RESEARCH CENTER				SCHEM No.	

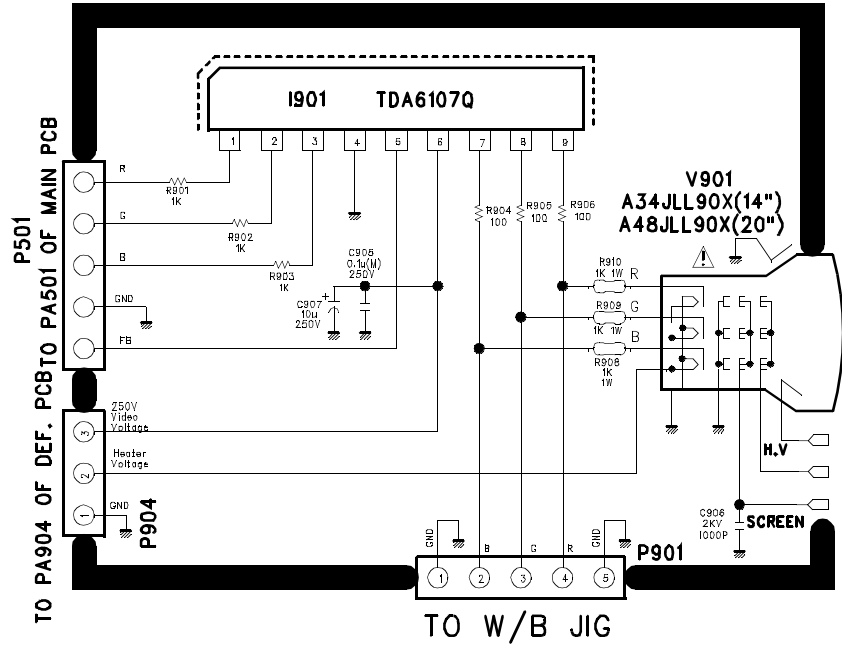

CP-062 DEF./CRT PART CIRCUIT

EXPLODED VIEW

1. DVT-14H1F

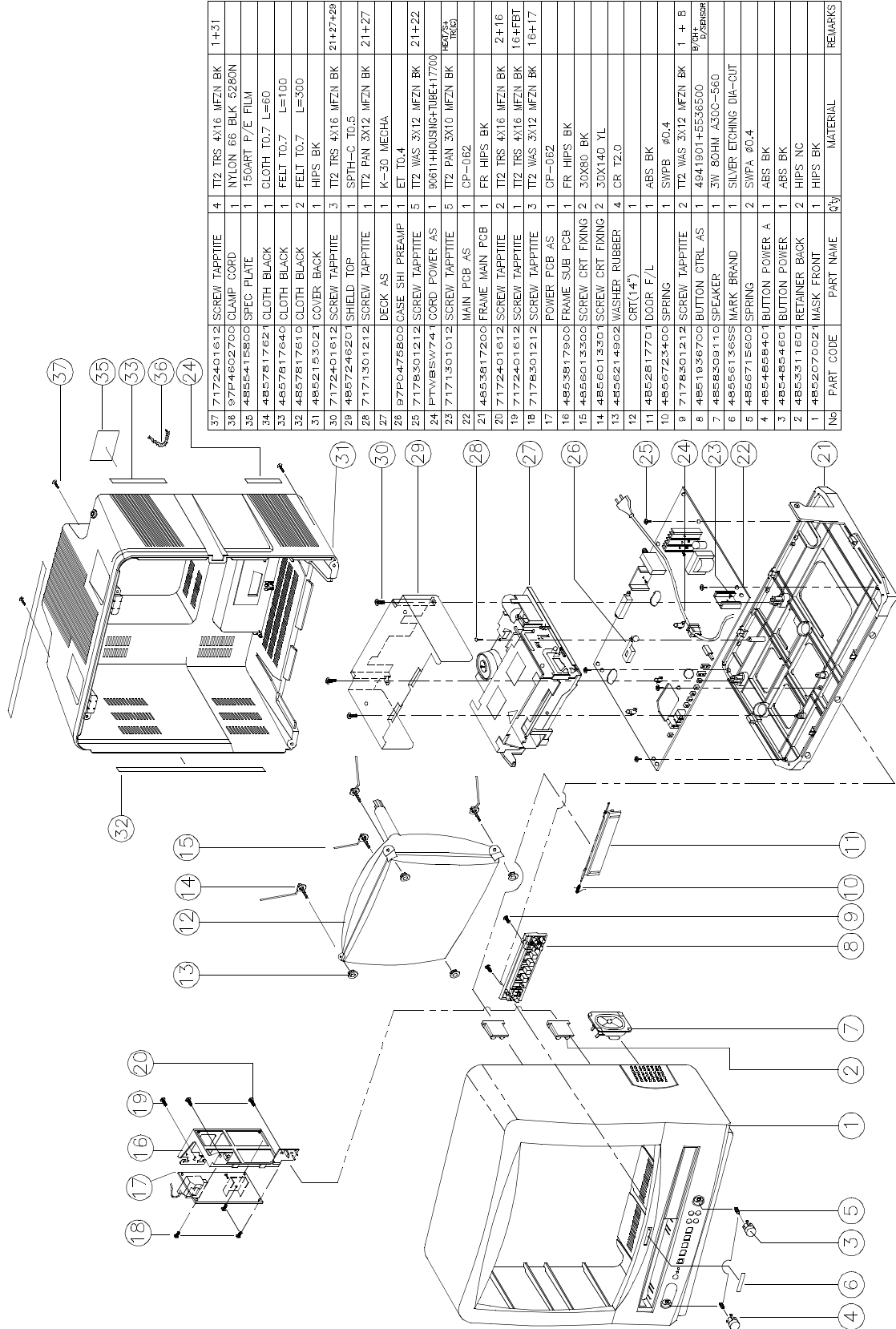

NO	PART CODE	PART NAME	QTY	MATERIAL	REMARKS
37	7172401612	SCREW TAPPTITE	4	T12 TRS 4X16 MFZN BK	1+31
36	97E4692700	CLAMP CORD	1	NYLON 66 BLK 5260N	
35	4855415800	SPEC PLATE	1	150ART P/E FILM	
34	4857817621	CLOTH BLACK	1	CLOTH T0.7 L=60	
33	4857817640	CLOTH BLACK	1	FELT T0.7 L=100	
32	4857817610	CLOTH BLACK	2	FELT T0.7 L=300	
31	4852153021	COVER BACK	1	HIPS BK	
30	7172401612	SCREW TAPPTITE	3	T12 TRS 4X16 MFZN BK	21+27+29
29	4857249201	SHIELD TOP	1	SPFH-C T0.5	
28	7171301012	SCREW TAPPTITE	1	T12 PAN 3X12 MFZN BK	21+27
27	97P0475800	DECK AS	1	K-30. MECHA	
26	97P0475800	CASE SHI PREAMP	1	ET T0.4	
25	7178301212	SCREW TAPPTITE	5	T12 WAS 3X12 MFZN BK	21+22
24	PTVBSW741	CORD POWER AS	1	90611+HOUSING+TUBE+17700	
23	7171301012	SCREW TAPPTITE	5	T12 PAN 3X10 MFZN BK	HEAT/SK TRIG1
22		MAIN PCB AS	1	CP-062	
21	4853617200	FRAME MAIN PCB	1	FR HIPS BK	
20	7172401612	SCREW TAPPTITE	2	T12 TRS 4X16 MFZN BK	2+16
19	7172401612	SCREW TAPPTITE	1	T12 TRS 4X16 MFZN BK	16+FEET
18	7178301212	SCREW TAPPTITE	3	T12 WAS 3X12 MFZN BK	16+17
17		POWER PCB AS	1	CP-062	
16	4853617900	FRAME SUB PCB	1	FR HIPS BK	
15	4856013300	SCREW CRT FIXING	2	30X80 BK	
14	4856013301	SCREW CRT FIXING	2	30X140 YL	
13	4856214902	WASHER RUBBER	4	CR T2.0	
12		CRT(14")	1		
11	4852817701	DOOR F/L	1	ABS BK	
10	4856723400	SPRING	1	SWPB 40.4	
9	7178301212	SCREW TAPPTITE	2	T12 WAS 3X12 MFZN BK	1 + B
8	48518336700	BUTTON CTRL AS	1	4941901+5536500	B/CNT/REVERSE
7	4856309110	SPEAKER	1	3W 80HM 4300-560	
6	4856613688	MARK BRAND	1	SILVER ETCHING DIA-CUT	
5	4856715600	SPRING	2	SWPA 0.4	
4	4854559940	BUTTON POWER A	1	ABS BK	
3	4854554601	BUTTON POWER B	1	ABS BK	
2	4853311601	RETAINER BACK	2	HIPS NC	
1	485207002	MASK FRONT	1	HIPS BK	
NO	PART CODE	PART NAME	QTY	MATERIAL	REMARKS

2. DVT-20H1F

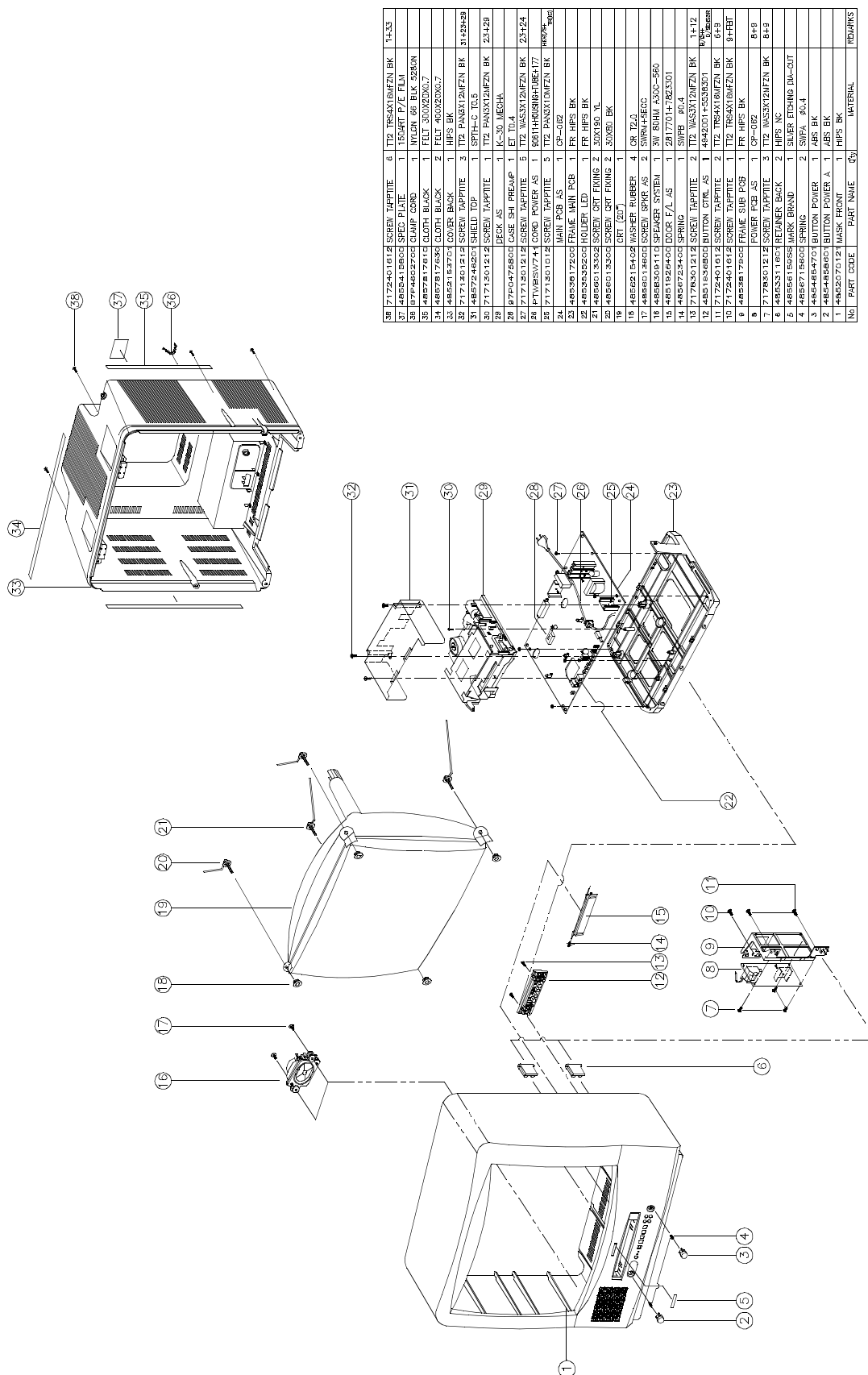

38	71724401814	SCREW TAPPTITE	6	T2 TRSAX18M1FZN BK	14-33
37	4858418800	SPEC PLATE	1	150MM P/E FILM	
36	87444022200	CLAMP CARD	1	NYLON 66 BLK 428MM	
35	44557817610	CLOTH BLACK	1	FELT 300X200X0.7	
34	44627817685	CLOTH BLACK	2	FELT 400X200X0.7	
33	44628182700	COVER BACK	1	HIPS BK	
32	71713016114	SCREW TAPPTITE	3	T2 PANX12M1FZN BK	31429498
31	48572448200	SHIELD TOP	1	SPTH-C T0.5	
30	71713016114	SCREW TAPPTITE	1	T2 PANX12M1FZN BK	234291
29	87444022200	CASE SHI PREAMP	1	K-30 MESH	
28	71713016114	SCREW TAPPTITE	5	ET T0.4	
27	44557817685	CLOTH BLACK	1	T2 WASX12M1FZN BK	23124
26	44557817685	CLOTH BLACK	1	100THRU08H08H17	
25	71713016114	SCREW TAPPTITE	5	T2 PANX10M1FZN BK	16098
24	44557817685	CLOTH BLACK	1	CP-002	
23	44557817685	CLOTH BLACK	1	FR HIPS BK	
22	44557817685	CLOTH BLACK	1	FR HIPS BK	
21	44557817685	CLOTH BLACK	1	FR HIPS BK	
20	44557817685	CLOTH BLACK	1	FR HIPS BK	
19	44557817685	CLOTH BLACK	1	FR HIPS BK	
18	44557817685	CLOTH BLACK	1	FR HIPS BK	
17	44557817685	CLOTH BLACK	1	FR HIPS BK	
16	44557817685	CLOTH BLACK	1	FR HIPS BK	
15	44557817685	CLOTH BLACK	1	FR HIPS BK	
14	44557817685	CLOTH BLACK	1	FR HIPS BK	
13	44557817685	CLOTH BLACK	1	FR HIPS BK	
12	44557817685	CLOTH BLACK	1	FR HIPS BK	
11	44557817685	CLOTH BLACK	1	FR HIPS BK	
10	44557817685	CLOTH BLACK	1	FR HIPS BK	
9	44557817685	CLOTH BLACK	1	FR HIPS BK	
8	44557817685	CLOTH BLACK	1	FR HIPS BK	
7	44557817685	CLOTH BLACK	1	FR HIPS BK	
6	44557817685	CLOTH BLACK	1	FR HIPS BK	
5	44557817685	CLOTH BLACK	1	FR HIPS BK	
4	44557817685	CLOTH BLACK	1	FR HIPS BK	
3	44557817685	CLOTH BLACK	1	FR HIPS BK	
2	44557817685	CLOTH BLACK	1	FR HIPS BK	
1	44557817685	CLOTH BLACK	1	FR HIPS BK	
NO	PART CODE	PART NAME	QTY	MATERIAL	REMARKS

SERVICE PARTS LIST

CAUTION

"△" is safety component, so it must be used the same component.
 "Ⓜ" is recomendable part for stock.

✓ **Caution:** In this Service Manual, some parts can be changed for improving, their performance without notice in the parts list. So, if you need the latest parts information, please refer to PPL(Parts Price List) in Service information Center(<http://svc.dwe.co.kr>)

LOC	PART CODE	PART NAME	DESCRIPTION	REMARK	LOC	PART CODE	PART NAME	DESCRIPTION	REMARK
ZZ100	48B446C04	TRANSMITTER REMOCON	R-46C04 (AAA)	Ⓜ	M561	4855613600	MARK BRAND	COPPER T0.4	
ZZ110	PTACPWA643	ACCESSORY AS	DVT-14H1F		ZZ200	PTFMSJA643	MASK FRONT AS	DVT-14H1F	Ⓜ
10	4850Q00910	BATTERY	R03/NN		M201	4852070021	MASK FRONT	HIPS BK	
20	4850A03310	ANT ROD	PH-RM-008A		M331	4853311601	RETAINER BACK	HIPS NC	
M821	4858213800	BAG INSTRUCTION	L.D.P.E T0.05X250X400		ZZ210	PTSPPPWA643	SPEAKER AS	DVT-14H1F	Ⓜ
ZZ120	PTBCSHA643	COVER BACK AS	DVT-14H1F	Ⓜ	PA601	4850703551	CONNECTOR	YH025-03+35098+ULW=300	
M211	4852153021	COVER BACK	HIPS BK		SP01	4858314310	SPEAKER	SP-5070A01 3W 8 OHM	Ⓜ
M541	4855415800	SPEC PLATE	150ART P/E FILM (C/TV)		ZZ290	PTMPMSA643	PCB MAIN MANUAL AS	DVT-14H1F	Ⓜ
M781	4857817610	CLOTH BLACK	FELT 300X20X0.7		C801	CL1JB3474K	C LINE ACROSS	AC250V 0.47MF U/C/SNDF/S	
M782	4857817640	CLOTH BLACK	FELT 100X20X0.7		C804	CEYN2G101P	C ELECTRO	400V LHS 100MF (22X30)	△
M783	4857817621	CLOTH BLACK	CLOTH T0.7 L=60		C806	CCYR3D471K	C CERA	2KV R 470PF K 125 DE0907	
ZZ130	PTPKCPA643	PACKING AS	DVT-14H1F		C810	CH1AFE472M	C CERA AC	4KV 4700PF M KX DE1610	△
M801	4858042700	BOX CARTON	SW-3		D821	DRGP30J---	DIODE	RGP30J	△
M801A	6520010100	STAPLE PIN	18MM J D O		DN03	DS15312H--	LED IR	SI5312-H	
M811	4858189400	PAD	EPS 14H1		DN03A	97P2339600	HOLDER IR	ABS	
M822	4858215700	BAG PE	PE FOAM 10.5x1000X950		DQ01	DLH2PR----	LED BLOCK	LH-2P-R	
ZZ131	48519A4710	CRT GROUND NET	1401S-1015-1P		DQ02	DLH2PR----	LED BLOCK	LH-2P-R	
ZZ132	58G0000084	COIL DEGAUSSING	DC-1450	△	F801	5FSCB4022R	FUSE CERA	SEMKO F4AH 4A 250V MF51	△
ZZ140	PTCACAA643	CABINET AS	DVT-14H1F		I501	1TDA8841--	IC VIDEO	TDA8841	Ⓜ
CRT1	PTRTPWA643	CRT AS	DVT-14H1F	Ⓜ	I502	1TC4066BP-	IC	TC 4066BP	Ⓜ
V01	58D1000046	COIL DY	ODY-M1401		I601	PTM2SW5400	HEAT SINK ASS'Y	1TDA8943SF + 7174300811	
V02	48A96R004-	RUBBER WEDGE	HMR 28 SR (10X54)		1	1TDA8943SF	IC AUDIO AMP	TDA8943SF	
V03	4850PM001-	MAGNET CP	NY-225 (MINI NECK)		0000A	4857025400	HEAT SINK	A1050P-H24 T2.0	
V04	2TC26019BE	TAPE CLOTH	19X30 BEIGE		0000B	7174300811	SCREW TAPPTITE	TT2 RND 3X8 MFZN	
V05	2224050033	BOND SILICON	RTV 252		I701	1SDA555XFL	IC MICOM OTP	SDA555XFL	Ⓜ
V901	48A96414P1	CRT BARE	A34JLL90X	△	I702	1AT24C08PC	IC	AT24C08-10PC	Ⓜ
M191	4851936700	BUTTON CTRL	4941901+5536500	Ⓜ	I801	PTG2SW7701	HEAT SINK ASS'Y	1STRF6653- + 7174300811	
M191A	7178301212	SCREW TAPPTITE	TT2 WAS 3X12 MFZN BK		1	1STRF6653-	IC SMPS	STR-F6653	
M201A	4856013300	SCREW CRT FIXING	30X80 BK		0000A	4857027701	HEAT SINK	AL EX	
M201B	4856013301	SCREW CRT FIXING	30X140 YL		0000B	7174300811	SCREW TAPPTITE	TT2 RND 3X8 MFZN	
M201C	4856214902	WASHER RUBBER	CR T2.0		I802	1LTV817C--	IC PHOTO COUPLER	LTV-817C	Ⓜ
M211A	7172401612	SCREW TAPPTITE	TT2 TRS 4X16 MFZN BK		I821	1SE125N---	IC	SE125N	Ⓜ
M281	4852817720	DOOR F/L	ABS BK SILK		I822	TX0202DA--	THYRISTOR	X0202DA1BA2	
M281A	4856723400	SPRING	SWPB 0.4		I823	PTB3SW1201	HEAT SINK ASS'Y	1K1A7808/06/P1+7174300811	Ⓜ
M351	4853535600	HOLDER CORD	NYROLN 66		I823	1K1A7808P1	IC REGULATOR	KIA7808API	
M382A	7172401612	SCREW TAPPTITE	TT2 TRS 4X16 MFZN BK		I823A	4857031201	HEAT SINK	AL 6063S	
M481	4854854601	BUTTON POWER	ABS BK	Ⓜ	I823B	7174300811	SCREW TAPPTITE	TT2 RND 3X8 MFZN	
M481A	4856715600	SPRING	SWPA PIE 0.4		I824	1K1A7806P1	IC REGULATOR	KIA7806API	Ⓜ
M482	4854858401	BUTTON POWER A	ABS BK		I827	1K1A7812P1	IC REGULATOR	KIA7812API	Ⓜ
M482A	4856715600	SPRING	SWPA PIE 0.4		I825	1K1A7806P1	IC REGULATOR	KIA7806API	Ⓜ

SERVICE PARTS LIST

LOC	PART CODE	PART NAME	DESCRIPTION	REMARK	LOC	PART CODE	PART NAME	DESCRIPTION	REMARK
I826	1LE33CZ---	IC REGULATOR	1E33CZ	Ⓡ	TU01	5800000032	COIL OSC	DE0-006	
I901	PTB3SW1300	HEAT SINK ASS'Y	1TDA6107Q- + 7174301011		U101	4859719930	TUNER VARACTOR	DT5-BF18D	Ⓡ
1	1TDA6107Q-	IC VIDEO	TDA6107Q	Ⓡ	X701	5XE6R0000C	CRYSTAL QUARTZ	HC-49/U 6.0000 MHZ 20PPM	
0000A	4857031300	HEAT SINK	A1050P-H24 T1.6		XN01	5XJ16R000E	CRYSTAL QUARTZ	HC-49S 16.000000MHZ 30PPM	
0000B	7174301011	SCREW TAPPTITE	TT2 RND 3X10 MFZN		XN02	5XYR03276C	CRYSTAL QUARTZ	C-001R 32.768000KHZ 20PPM	
IN02	1K1A6801K-	IC MOTOR DRIVER	KIA6801K		Z503	5PYXT5R5MB	FILTER CERA	XT 5.5MB	
IQ01	1KRT30----	IC PREAMP	KRT30	Ⓡ	ZZ200	PTMPJ2A643	PCB CHIP MOUNT B A	DVT-14H1F	
JS01	4859200401	SOCKET RGB	YRS21-R1		CC501	HCQK221JCA	C CHIP CERA	50V CH 220PF J 2012	
L801	5PLF24A1--	FILTER LINE	LF-24A1	⚠	CC512	HCBK103KCA	C CHIP CERA	50V X7R 0.01MF K 2012	
M193	4851942300	DECK AS	DRP-9200N		CC517	HCQK181JCA	C CHIP CERA	50V CH 180PF J 2012	
M351	97P0475800	CASE SHI PREAMP	ET T0.4		CC520	HCFK104ZCA	C CHIP CERA	50V Y5V 0.1MF Z 2012	
M353	4853535500	HOLDER CORD	NYROLN 66		CC521	HCFK104ZCA	C CHIP CERA	50V Y5V 0.1MF Z 2012	
M381	4853817200	FRAME MAIN PCB	FR HIPS BK		CC522	HCFK104ZCA	C CHIP CERA	50V Y5V 0.1MF Z 2012	
M381A	7178301212	SCREW TAPPTITE	TT2 WAS 3X12 MFZN BK		CC524	HCFK104ZCA	C CHIP CERA	50V Y5V 0.1MF Z 2012	
M391	4853948400	BRKT EARTH	C5212P-1/2M T0.15		CC525	HCFK104ZCA	C CHIP CERA	50V Y5V 0.1MF Z 2012	
M721	4857246201	SHIELD TOP	SPTH-C T0.5		CC530	HCBK103KCA	C CHIP CERA	50V X7R 0.01MF K 2012	
M721A	7172401612	SCREW TAPPTITE	TT2 TRS 4X16 MFZN BK		CC533	HCQK181JCA	C CHIP CERA	50V CH 180PF J 2012	
M721B	7171301212	SCREW TAPTITE	TT2 PAN 3X12 MFZN BK		CC535	HCBK332KCA	C CHIP CERA	50V X7R 3300PF K 2012	
P801	4859287320	CONN WAFER	MKS2822-6-10-202		CC536	HCBK472KCA	C CHIP CERA	50V X7R 4700PF K 2012	
P901	4859289920	CONN WAFER	YFW254-05S		CC538	HCQK181JCA	C CHIP CERA	50V CH 180PF J 2012	
PA501	4850705S04	CONNECTOR	YH025-05+YST025+ULW=400		CC539	HCQK181JCA	C CHIP CERA	50V CH 180PF J 2012	
PA807	4850710V03	CONNECTOR	YH025-10+YST025+ULW=400		CC703	HCBK103KCA	C CHIP CERA	50V X7R 0.01MF K 2012	
PAN01	4850707V04	CONNECTOR	60-8283-3078-45+ULW=200		CC712	HCBK103KCA	C CHIP CERA	50V X7R 0.01MF K 2012	
PAY01	4850706N07	CONNECTOR	60-8283-3068-45+USW=250		CC713	HCQK221JCA	C CHIP CERA	50V CH 220PF J 2012	
PN02	4859292320	CONN WAFER	GF120-07S-TS		CC722	HCBK103KCA	C CHIP CERA	50V X7R 0.01MF K 2012	
PN02A	4859200170	CONN FFC	K-7X100-0.25		CC724	HCBK103KCA	C CHIP CERA	50V X7R 0.01MF K 2012	
PN03	4859278220	CONN WAFER	TKC-G10P-A1		CC726	HCQK330JCA	C CHIP CERA	50V CH 33PF J 2012	
PWC1	PTWBSW7410	CORD POWER ASS'Y	906111+HOUSING+TUBE+177	⚠	CC727	HCQK330JCA	C CHIP CERA	50V CH 33PF J 2012	
PW000	4859906111	CORD POWER	M5206+H03VVH2-F=2250		CC728	HCBK103KCA	C CHIP CERA	50V X7R 0.01MF K 2012	
PW001	4857417700	TERM CLAMP	PT-01-T3		CC730	HCBK103KCA	C CHIP CERA	50V X7R 0.01MF K 2012	
PY02	4859292220	CONN WAFER	GF120-04S-TS-R		CC732	HCBK103KCA	C CHIP CERA	50V X7R 0.01MF K 2012	
R801	DEC140M290	POSISTOR	ECPC140M290	⚠	CC862	HCBK103KCA	C CHIP CERA	50V X7R 0.01MF K 2012	
R802	RX10T339J-	R CEMENT	10W 3.3 OHM J TRIPOD		CC863	HCBK103KCA	C CHIP CERA	50V X7R 0.01MF K 2012	
RLY1	5SC0101338	SW RELAY	DO5D1-0(M)/GJ-SS-105LM	Ⓡ	CC864	HCBK103KCA	C CHIP CERA	50V X7R 0.01MF K 2012	
SCT01	4859303430	SOCKET CRT	PCS633A	Ⓡ	CC865	HCBK103KCA	C CHIP CERA	50V X7R 0.01MF K 2012	
SF501	5PG1966M--	FILTER SAW	G1966M		CCA03	HCBK102KCA	C CHIP CERA	50V X7R 1000PF K 2012	
SG01	4SG0D00103	SPARK GAP	S-23 900V-1.5KV		CCA05	HCBK102KCA	C CHIP CERA	50V X7R 1000PF K 2012	
SN01	TST5811---	TR PHOTO	ST-5811		CCA06	HCBK102KCA	C CHIP CERA	50V X7R 1000PF K 2012	
SN01A	97P2343500	HOLDER TR	ABS FR		CCA07	HCBK102KCA	C CHIP CERA	50V X7R 1000PF K 2012	
SN02	TST5811---	TR PHOTO	ST-5811		CCA20	HCBK102KCA	C CHIP CERA	50V X7R 1000PF K 2012	
SN02A	97P2343500	HOLDER TR	ABS FR		CCY15	HCBK103KCA	C CHIP CERA	50V X7R 0.01MF K 2012	
SN03	4850S00001	SENSOR REEL	SG-258S		CCY34	HCBK103KCA	C CHIP CERA	50V X7R 0.01MF K 2012	
SN04	4850S00001	SENSOR REEL	SG-258S		CCY50	HCQK510JCA	C CHIP CERA	50V CH 51PF J 2012	
SW10	5S50202002	SW TACT	KPT-2105A 2C-2P		CCY51	HCQK300JCA	C CHIP CERA	50V CH 30PF J 2012	
SW12	5S50202002	SW TACT	KPT-2105A 2C-2P		CCY52	HCQK300JCA	C CHIP CERA	50V CH 30PF J 2012	
SW801	5S40101146	SW POWER PUSH	SS-160-7-B		ICN01	1M37777EFQ	IC CHIP MICOM	M37777EFAGP	
SWN01	5SN0101Z20	SW DETECT	JDS1105-6X		ICY01	1LA71598MQ	IC CHIP Y/C	LA71598SM	

SERVICE PARTS LIST

LOC	PART CODE	PART NAME	DESCRIPTION	REMARK	LOC	PART CODE	PART NAME	DESCRIPTION	REMARK
QC501	T2SC1623T2	TR CHIP	2SC1623-L6/T2B		RCA04	HRFT154JCA	R CHIP	1/10 150K OHM J 2012	
QC502	T2SC1623T2	TR CHIP	2SC1623-L6/T2B		RCA05	HRFT153JCA	R CHIP	1/10 15K OHM J 2012	
QC503	T2SA812T2B	TR CHIP	2SA812-T2B		RCN22	HRFT105JCA	R CHIP	1/10 1M OHM J 2012	
QC504	T2SC1623T2	TR CHIP	2SC1623-L6/T2B		RCN23	HRFT511JCA	R CHIP	1/10 510 OHM J 2012	
QC505	T2SC1623T2	TR CHIP	2SC1623-L6/T2B		RCN25	HRFT106JCA	R CHIP	1/10 10M OHM J 2012	
QC506	T2SA812T2B	TR CHIP	2SA812-T2B		RCN26	HRFT104JCA	R CHIP	1/10 100K OHM J 2012	
QC508	T2SC1623T2	TR CHIP	2SC1623-L6/T2B		RCY18	HRFT563JCA	R CHIP	1/10 56K OHM J 2012	
QC605	T2SC1623T2	TR CHIP	2SC1623-L6/T2B		RCY50	HRFT511JCA	R CHIP	1/10 510 OHM J 2012	
QC702	T2SC1623T2	TR CHIP	2SC1623-L6/T2B		ZZ200	PTMPJ0A643	PCB MAIN (RHU) AS	DVT-14H1F	
QC703	T2SA812T2B	TR CHIP	2SA812-T2B		C620	CEXF1E331V	C ELECTRO	25V RSS 330MF (10X12.5)TP	
QC704	T2SC1623T2	TR CHIP	2SC1623-L6/T2B		C805	CEXF2W100V	C ELECTRO	450V RSS 10MF (13X20) TP	
QC707	T2SC1623T2	TR CHIP	2SC1623-L6/T2B		C821	CEXF2C101V	C ELECTRO	160V RSS 100MF (16X25) TP	
QC708	T2SC1623T2	TR CHIP	2SC1623-L6/T2B		C822	CEXF1C102V	C ELECTRO	16V RSS 1000MF (10X20) TP	
QC710	T2SA812T2B	TR CHIP	2SA812-T2B		C823	CEXF1E102V	C ELECTRO	25V RSS 1000MF (13X20) TP	
QC711	T2SC1623T2	TR CHIP	2SC1623-L6/T2B		C824	CEXF1C102V	C ELECTRO	16V RSS 1000MF (10X20) TP	
QCN01	T2SC1623T2	TR CHIP	2SC1623-L6/T2B		C825	CEXF1E102V	C ELECTRO	25V RSS 1000MF (13X20) TP	
QCU05	T2SA812T2B	TR CHIP	2SA812-T2B		C837	CEXF1V102V	C ELECTRO	35V RSS 1000MF (13X25) TP	
QCU06	T2SC1623T2	TR CHIP	2SC1623-L6/T2B		C850	CEXF2C470V	C ELECTRO	160V RSS 47MF (13X25) TP	
QCU07	T2SC1623T2	TR CHIP	2SC1623-L6/T2B		C906	CCXB3D102K	C CERA	2KV B 1000PF K (TAPPING)	
QCY01	TKTC3121-B	TR CHIP	KTC3121-B		CN28	CEXF1A471V	C ELECTRO	10V RSS 470MF (8X11.5) TP	
QCY02	T2SC1623T2	TR CHIP	2SC1623-L6/T2B		ZZ200	PTMPJBA643	PCB MAIN M-10 AS	DVT-14H1F	
QCY03	T2SA812T2B	TR CHIP	2SA812-T2B		10	2TM18006BE	TAPE MASKING	6.2X500	
QCY04	T2SA812T2B	TR CHIP	2SA812-T2B		E001	4856310300	EYE LET	BSR T0.2 (R1.6)	
QCY05	T2SC1623T2	TR CHIP	2SC1623-L6/T2B		E002	4856310300	EYE LET	BSR T0.2 (R1.6)	
QCY06	T2SC1623T2	TR CHIP	2SC1623-L6/T2B		E003	4856310300	EYE LET	BSR T0.2 (R1.6)	
QCY50	T2SC1623T2	TR CHIP	2SC1623-L6/T2B		E004	4856310300	EYE LET	BSR T0.2 (R1.6)	
RC510	HRFT221JCA	R CHIP	1/10 220 OHM J 2012		E005	4856310300	EYE LET	BSR T0.2 (R1.6)	
RC511	HRFT221JCA	R CHIP	1/10 220 OHM J 2012		E006	4856310300	EYE LET	BSR T0.2 (R1.6)	
RC514	HRFT241JCA	R CHIP	1/10 240 OHM J 2012		E007	4856310300	EYE LET	BSR T0.2 (R1.6)	
RC519	HRFT103JCA	R CHIP	1/10 10K OHM J 2012		E008	4856310300	EYE LET	BSR T0.2 (R1.6)	
RC520	HRFT101JCA	R CHIP	1/10 100 OHM J 2012		E009	4856310300	EYE LET	BSR T0.2 (R1.6)	
RC521	HRFT101JCA	R CHIP	1/10 100 OHM J 2012		E010	4856310600	EYE LET	BSR T0.2 (R2.3)	
RC522	HRFT101JCA	R CHIP	1/10 100 OHM J 2012		E011	4856310600	EYE LET	BSR T0.2 (R2.3)	
RC523	HRFT753JCA	R CHIP	1/10 75K OHM J 2012		E012	4856310600	EYE LET	BSR T0.2 (R2.3)	
RC524	HRFT182JCA	R CHIP	1/10 1.8K OHM J 2012		E015	4856310600	EYE LET	BSR T0.2 (R2.3)	
RC526	HRFT104JCA	R CHIP	1/10 100K OHM J 2012		E016	4856310600	EYE LET	BSR T0.2 (R2.3)	
RC529	HRFT153JCA	R CHIP	1/10 15K OHM J 2012		E017	4856310600	EYE LET	BSR T0.2 (R2.3)	
RC701	HRFT472JCA	R CHIP	1/10 4.7K OHM J 2012		E018	4856310300	EYE LET	BSR T0.2 (R1.6)	
RC702	HRFT472JCA	R CHIP	1/10 4.7K OHM J 2012		E019	4856310300	EYE LET	BSR T0.2 (R1.6)	
RC703	HRFT472JCA	R CHIP	1/10 4.7K OHM J 2012		E020	4856310300	EYE LET	BSR T0.2 (R1.6)	
RC704	HRFT472JCA	R CHIP	1/10 4.7K OHM J 2012		E021	4856310600	EYE LET	BSR T0.2 (R2.3)	
RC714	HRFT472JCA	R CHIP	1/10 4.7K OHM J 2012		E022	4856310600	EYE LET	BSR T0.2 (R2.3)	
RC715	HRFT103JCA	R CHIP	1/10 10K OHM J 2012		E023	4856310600	EYE LET	BSR T0.2 (R2.3)	
RC732	HRFT472JCA	R CHIP	1/10 4.7K OHM J 2012		P101	485923162S	CONN WAFER	YW025-03 (STICK)	
RC780	HRFT223JCA	R CHIP	1/10 22K OHM J 2012		P501	485923182S	CONN WAFER	YW025-05 (STICK)	
RC781	HRFT103JCA	R CHIP	1/10 10K OHM J 2012		P601	485923162S	CONN WAFER	YW025-03 (STICK)	
RCA03	HRFT153JCA	R CHIP	1/10 15K OHM J 2012		P802A	4857417500	TERM PIN	DA-IB0214(D2.3/DY PIN)	

SERVICE PARTS LIST

LOC	PART CODE	PART NAME	DESCRIPTION	REMARK	LOC	PART CODE	PART NAME	DESCRIPTION	REMARK
P802B	4857417500	TERM PIN	DA-IB0214(D2.3/DY PIN)		C811	CEXF1H109V	C ELECTRO	50V RSS 1MF (5X11) TP	
P904	485923162S	CONN WAFER	YW025-03 (STICK)		C838	CEXF1E470V	C ELECTRO	25V RSS 47MF (5X11) TP	
PY03	485923202S	CONN WAFER	YW025-07 (STICK)		C842	CEXF1C101V	C ELECTRO	16V RSS 100MF (6.3X11) TP	
R809	RS02Z228JS	R M-OXIDE FILM	2W 0.22 OHM J SMALL	!	C843	CEXF1C101V	C ELECTRO	16V RSS 100MF (6.3X11) TP	
R832	RS02Z828JS	R M-OXIDE FILM	2W 0.82 OHM J SMALL		C844	CEXF1C101V	C ELECTRO	16V RSS 100MF (6.3X11) TP	
ZZ200	PTMPJRA643	PCB MAIN RADIAL AS	DVT-14H1F		C845	CEXF1C101V	C ELECTRO	16V RSS 100MF (6.3X11) TP	
C102	CEXF1H100V	C ELECTRO	50V RSS 10MF (5X11) TP		C846	CEXF1C101V	C ELECTRO	16V RSS 100MF (6.3X11) TP	
C105	CEXF1H101V	C ELECTRO	50V RSS 100MF (8X11.5) TP		C849	CEXF1C101V	C ELECTRO	16V RSS 100MF (6.3X11) TP	
C121	CEXF1E470V	C ELECTRO	25V RSS 47MF (5X11) TP		C851	CEXF1C101V	C ELECTRO	16V RSS 100MF (6.3X11) TP	
C507	CEXF1H228V	C ELECTRO	50V RSS 0.22MF (5X11) TP		C857	CEXF1H470V	C ELECTRO	50V RSS 47MF (6.3X11) TP	
C509	CEXF1H229A	C ELECTRO	50V RSM 2.2MF (4X7) TP		C858	CEXF1H470V	C ELECTRO	50V RSS 47MF (6.3X11) TP	
C511	CEXF1C101A	C ELECTRO	16V RSM 100MF (6.3X7) TP		C905	CMXL2E104K	C MYLAR	250V MEU 0.1MF K	
C515	CEXF1H478A	C ELECTRO	50V RSM 0.47MF 4X7		CA01	CEXF1C101A	C ELECTRO	16V RSM 100MF (6.3X7) TP	
C516	CEXF1H229A	C ELECTRO	50V RSM 2.2MF (4X7) TP		CA24	CEXF1C101A	C ELECTRO	16V RSM 100MF (6.3X7) TP	
C518	CMXM2A104J	C MYLAR	100V 0.1MF J (TP)		CN05	CEXF1C101V	C ELECTRO	16V RSS 100MF (6.3X11) TP	
C519	CEXF1H478A	C ELECTRO	50V RSM 0.47MF 4X7		CN08	CEXF1C101A	C ELECTRO	16V RSM 100MF (6.3X7) TP	
C523	CEXF1H220V	C ELECTRO	50V RSS 22MF (5X11) TP		CN09	CXCH1H220J	C CERA	50V CH 22PF J (TAPPING)	
C527	CXCH1H150J	C CERA	50V CH 15PF J (TAPPING)		CN10	CXCH1H220J	C CERA	50V CH 22PF J (TAPPING)	
C528	CEXF1H478A	C ELECTRO	50V RSM 0.47MF 4X7		CN11	CDXF0H104K	C SUPER	5.5V 0.1F F (TAPPING)	
C531	CEXF1C101A	C ELECTRO	16V RSM 100MF (6.3X7) TP		CN12	CXCH1H180J	C CERA	50V CH 18PF J (TAPPING)	
C532	CEXF1H109A	C ELECTRO	50V RSM 1MF (4X7) TP		CN13	CXCH1H180J	C CERA	50V CH 18PF J (TAPPING)	
C534	CEXF1H478A	C ELECTRO	50V RSM 0.47MF 4X7		CN15	CEXF1H109A	C ELECTRO	50V RSM 1MF (4X7) TP	
C537	CEXF1H109A	C ELECTRO	50V RSM 1MF (4X7) TP		CN18	CEXF1C101V	C ELECTRO	16V RSS 100MF (6.3X11) TP	
C541	CMXM2A104J	C MYLAR	100V 0.1MF J (TP)		CN26	CEXF1C101A	C ELECTRO	16V RSM 100MF (6.3X7) TP	
C542	CEXD1H109F	C ELECTRO	50V RND 1MF (5X11) TP		CN27	CEXF1C101A	C ELECTRO	16V RSM 100MF (6.3X7) TP	
C544	CEXF1H229A	C ELECTRO	50V RSM 2.2MF (4X7) TP		CN29	CEXF1C470A	C ELECTRO	16V RSM 47MF (5X7) TP	
C545	CEXF1C100A	C ELECTRO	16V RSM 10MF 5X7		CN31	CEXF1C470A	C ELECTRO	16V RSM 47MF (5X7) TP	
C547	CEXF1C101A	C ELECTRO	16V RSM 100MF (6.3X7) TP		CN33	CEXF1C101A	C ELECTRO	16V RSM 100MF (6.3X7) TP	
C549	CEXF1H478A	C ELECTRO	50V RSM 0.47MF 4X7		CU02	CMXM2A103J	C MYLAR	100V 0.01MF J (TP)	
C551	CEXF1C101A	C ELECTRO	16V RSM 100MF (6.3X7) TP		CU03	CMXM2A473J	C MYLAR	100V 0.047MF J (TP)	
C609	CEXF1H220V	C ELECTRO	50V RSS 22MF (5X11) TP		CU04	CMXM2A104J	C MYLAR	100V 0.1MF J (TP)	
C613	CMXM2A224J	C MYLAR	100V 0.22MF J		CU05	CEXF1H479A	C ELECTRO	50V RSM 4.7MF 4X7	
C614	CEXF1H100V	C ELECTRO	50V RSS 10MF (5X11) TP		CU07	CMXM2A822J	C MYLAR	100V 8200PF J (TP)	
C615	CEXF1C220A	C ELECTRO	16V RSM 22MF (5X7)		CU10	CEXF1E470V	C ELECTRO	25V RSS 47MF (5X11) TP	
C617	CEXF1H478A	C ELECTRO	50V RSM 0.47MF 4X7		CU12	CEXF1C220A	C ELECTRO	16V RSM 22MF (5X7)	
C619	CMXM2A224J	C MYLAR	100V 0.22MF J		CU13	CEXF1H479A	C ELECTRO	50V RSM 4.7MF 4X7	
C702	CEXF1C470A	C ELECTRO	16V RSM 47MF (5X7) TP		CU14	CMXM2A272J	C MYLAR	100V 2700PF J (TP)	
C704	CEXF1C470A	C ELECTRO	16V RSM 47MF (5X7) TP		CU15	CMXM2A122J	C MYLAR	100V 1200PF J (TP)	
C706	CEXF1C470A	C ELECTRO	16V RSM 47MF (5X7) TP		CU16	CMXM2A103J	C MYLAR	100V 0.01MF J (TP)	
C723	CEXF1C470A	C ELECTRO	16V RSM 47MF (5X7) TP		CU17	CMXM2A333J	C MYLAR	100V 0.033MF J (TP)	
C729	CEXF1C470A	C ELECTRO	16V RSM 47MF (5X7) TP		CU18	CEXF1E470V	C ELECTRO	25V RSS 47MF (5X11) TP	
C731	CEXF1C470A	C ELECTRO	16V RSM 47MF (5X7) TP		CU19	CMXM2A223J	C MYLAR	100V 0.022MF J TP	
C733	CEXF1C470A	C ELECTRO	16V RSM 47MF (5X7) TP		CU21	CEXF1C101V	C ELECTRO	16V RSS 100MF (6.3X11) TP	
C802	CCXF3A472Z	C CERA	1KV F 4700PF Z (T)		CU23	CEXF1C220A	C ELECTRO	16V RSM 22MF (5X7)	
C803	CCXF3A472Z	C CERA	1KV F 4700PF Z (T)		CU24	CEXF1C470A	C ELECTRO	16V RSM 47MF (5X7) TP	
C807	CEXF1E470V	C ELECTRO	25V RSS 47MF (5X11) TP		CY01	CEXF1H109A	C ELECTRO	50V RSM 1MF (4X7) TP	
C809	CCXB1H152K	C CERA	50V B 1500PF K (TAPPING)		CY02	CMXM2A473J	C MYLAR	100V 0.047MF J (TP)	

SERVICE PARTS LIST

LOC	PART CODE	PART NAME	DESCRIPTION	REMARK	LOC	PART CODE	PART NAME	DESCRIPTION	REMARK
CY03	CEXF1H109A	C ELECTRO	50V RSM 1MF (4X7) TP		Q835	TKTA1266Y-	TR	KTA1266Y (TP)	
CY05	CEXF1C101A	C ELECTRO	16V RSM 100MF (6.3X7) TP		Q836	TKTC3198Y-	TR	KTC3198Y	
CY08	CXCH1H509D	C CERA	50V CH 5PF D (TAPPING)		Q837	TKTC3198Y-	TR	KTC3198Y	
CY10	CEXF1H479A	C ELECTRO	50V RSM 4.7MF 4X7		QQ01	TKSR1001--	TR	KSR1001	
CY16	CEXF1C101A	C ELECTRO	16V RSM 100MF (6.3X7) TP		QQ02	TKSR1001--	TR	KSR1001	
CY17	CEXF1C100A	C ELECTRO	16V RSM 10MF 5X7		QU02	TKSR1001--	TR	KSR1001	
CY18	CEXF1C220A	C ELECTRO	16V RSM 22MF (5X7)		QU03	TKTA1266Y-	TR	KTA1266Y (TP)	
CY21	CEXF1H109A	C ELECTRO	50V RSM 1MF (4X7) TP		QU04	TKTC3202Y-	TR	KTC3202Y (TP)	
CY24	CEXF1C470A	C ELECTRO	16V RSM 47MF (5X7) TP		R803	RN02B683JS	R METAL FILM	2W 68K OHM J SMALL	
CY26	CEXF1C101A	C ELECTRO	16V RSM 100MF (6.3X7) TP		R831	RN02B473JS	R METAL FILM	2W 47K OHM J SMALL	
CY28	CEXF1C100A	C ELECTRO	16V RSM 10MF 5X7		R836	RN02B229JS	R METAL FILM	2W 2.2 OHM J SMALL	
CY29	CEXF1H109A	C ELECTRO	50V RSM 1MF (4X7) TP		R837	RN02B360JS	R METAL FILM	2W 36 OHM J SMALL	
CY30	CEXF1H109A	C ELECTRO	50V RSM 1MF (4X7) TP		R841	RN02B562JS	R METAL FILM	2W 5.6K OHM J SMALL	
CY36	CEXF1C101A	C ELECTRO	16V RSM 100MF (6.3X7) TP		R842	RN02B562JS	R METAL FILM	2W 5.6K OHM J SMALL	
CY38	CEXF1C101A	C ELECTRO	16V RSM 100MF (6.3X7) TP		R856	RN02B229JS	R METAL FILM	2W 2.2 OHM J SMALL	
CY40	CEXF1H109A	C ELECTRO	50V RSM 1MF (4X7) TP		R859	RN02B229JS	R METAL FILM	2W 2.2 OHM J SMALL	
CY42	CEXF1H109A	C ELECTRO	50V RSM 1MF (4X7) TP		R908	RN01B102JS	R METAL FILM	1W 1K OHM J SMALL	
CY44	CEXF1H109A	C ELECTRO	50V RSM 1MF (4X7) TP		R909	RN01B102JS	R METAL FILM	1W 1K OHM J SMALL	
CY45	CMXM2A223J	C MYLAR	100V 0.022MF J TP		R910	RN01B102JS	R METAL FILM	1W 1K OHM J SMALL	
CY53	CEXF1C101A	C ELECTRO	16V RSM 100MF (6.3X7) TP		RN30	RN02B399JS	R METAL FILM	2W 3.9 OHM J SMALL	
CY58	CEXF1C100A	C ELECTRO	16V RSM 10MF 5X7		SW01	5S50101090	SW TACT	THVH472GCA	
CY59	CEXF1H109A	C ELECTRO	50V RSM 1MF (4X7) TP		SW02	5S50101090	SW TACT	THVH472GCA	
CY61	CMXM2A223J	C MYLAR	100V 0.022MF J TP		SW03	5S50101090	SW TACT	THVH472GCA	
CY62	CXCH1H150J	C CERA	50V CH 15PF J (TAPPING)		SW04	5S50101090	SW TACT	THVH472GCA	
D105	1UPC574J--	IC	UPC574J		SW07	5S50101090	SW TACT	THVH472GCA	
F801A	4857415001	CLIP FUSE	PFC5000-0702		SW08	5S50101090	SW TACT	THVH472GCA	
F801B	4857415001	CLIP FUSE	PFC5000-0702		X502	5XEX4R436C	CRYSTAL QUARTZ	HC-49U 4.433619M 20PP TA	
IN03	1K1A7033AP	IC RESET	KIA7033AP		XY01	5XEX4R436C	CRYSTAL QUARTZ	HC-49U 4.433619M 20PP TA	
IN04	1K1A7042AP	IC REGULATOR	KIA7042AP		Z501	5PXLT5R5MH	FILTER CERA	LT 5.5MH	
LU01	5CPX103J--	COIL PEAKING	10MH 5MM J RADIAL		ZZ200	PTMPJAA643	PCB MAIN AXIAL AS	DVT-14H1F	
O509	TKTC3198Y-	TR	KTC3198Y		10	2TM14006LB	TAPE MASKING	3M #232 6.0X2000M	
O601	TKTC3198Y-	TR	KTC3198Y		20	2TM10006LB	TAPE MASKING	3M #232-MAP-C 6.2X2000M	
O603	TKTA1266Y-	TR	KTA1266Y (TP)		A001	4859803993	PCB MAIN	330X246	
Q705	TKTC3198Y-	TR	KTC3198Y		C101	CCZF1H103Z	C CERA	50V F 0.01MF Z	
Q706	TH2N7000--	FET	H2N7000		C103	CCZB1H221K	C CERA	50V B 220PF K (AXIAL)	
Q709	TH2N7000--	FET	H2N7000		C104	CCZB1H221K	C CERA	50V B 220PF K (AXIAL)	
Q801	TKTC3207--	TR	KTC3207 (TP)		C106	CCZF1H103Z	C CERA	50V F 0.01MF Z	
Q802	TKTC3207--	TR	KTC3207 (TP)		C120	CCZF1H103Z	C CERA	50V F 0.01MF Z	
Q821	TKTC3198Y-	TR	KTC3198Y		C500	CBZF1H104Z	C CERA SEMI	50V F 0.1MF Z	
Q822	TKTC3198Y-	TR	KTC3198Y		C502	CCZB1H151K	C CERA	50V B 150PF K (AXIAL)	
Q823	TKTC3198Y-	TR	KTC3198Y		C504	CZSL1H560J	C CERA	50V SL 56PF J (AXIAL)	
Q824	TKTC3198Y-	TR	KTC3198Y		C505	CZSL1H220J	C CERA	50V SL 22PF J (AXIAL)	
Q825	TKTC3198Y-	TR	KTC3198Y		C506	CCZF1H103Z	C CERA	50V F 0.01MF Z	
Q827	TKSA1013Y-	TR	KSA1013Y (TP)		C508	CCZF1H223Z	C CERA	50V F 0.022MF Z	
Q828	TKTA1266Y-	TR	KTA1266Y (TP)		C510	CBZF1H104Z	C CERA SEMI	50V F 0.1MF Z	
Q829	TKTC3198Y-	TR	KTC3198Y		C529	CBZR1C472M	C CERA	16V Y5R 4700PF M (AXIAL)	
Q834	TKTC3203Y-	TR	KTC3203-Y		C540	CCZB1H102K	C CERA	50V B 1000PF K (AXIAL)	

SERVICE PARTS LIST

LOC	PART CODE	PART NAME	DESCRIPTION	REMARK	LOC	PART CODE	PART NAME	DESCRIPTION	REMARK
C543	CCZF1H103Z	C CERA	50V F 0.01MF Z		CY04	CCZF1H103Z	C CERA	50V F 0.01MF Z	
C546	CBZR1C392M	C CERA	16V Y5R 3900PF M (AXIAL)		CY06	CZSL1H270J	C CERA	50V SL 27PF J (AXIAL)	
C548	CCZB1H102K	C CERA	50V B 1000PF K (AXIAL)		CY07	CCZF1H103Z	C CERA	50V F 0.01MF Z	
C605	CCZB1H102K	C CERA	50V B 1000PF K (AXIAL)		CY09	CCZB1H391K	C CERA	50V B 390PF K (AXIAL)	
C606	CCZB1H102K	C CERA	50V B 1000PF K (AXIAL)		CY11	CCZB1H221K	C CERA	50V B 220PF K (AXIAL)	
C607	CCZB1H102K	C CERA	50V B 1000PF K (AXIAL)		CY19	CBZF1H104Z	C CERA SEMI	50V F 0.1MF Z	
C608	CCZB1H102K	C CERA	50V B 1000PF K (AXIAL)		CY20	CCZF1H103Z	C CERA	50V F 0.01MF Z	
C616	CCZF1H103Z	C CERA	50V F 0.01MF Z		CY22	CBZF1H104Z	C CERA SEMI	50V F 0.1MF Z	
C618	CCZF1H103Z	C CERA	50V F 0.01MF Z		CY23	CBZF1H104Z	C CERA SEMI	50V F 0.1MF Z	
C715	CCZF1H103Z	C CERA	50V F 0.01MF Z		CY25	CBZF1H104Z	C CERA SEMI	50V F 0.1MF Z	
C734	CCZB1H221K	C CERA	50V B 220PF K (AXIAL)		CY27	CCZF1H103Z	C CERA	50V F 0.01MF Z	
C808	CCZB1H102K	C CERA	50V B 1000PF K (AXIAL)		CY31	CCZF1H103Z	C CERA	50V F 0.01MF Z	
C827	CCZB1H471K	C CERA	50V B 470PF K (AXIAL)		CY32	CCZF1H103Z	C CERA	50V F 0.01MF Z	
C852	CCZF1H103Z	C CERA	50V F 0.01MF Z		CY33	CCZF1H103Z	C CERA	50V F 0.01MF Z	
C853	CCZF1H103Z	C CERA	50V F 0.01MF Z		CY35	CCZF1H103Z	C CERA	50V F 0.01MF Z	
C855	CCZF1H103Z	C CERA	50V F 0.01MF Z		CY37	CCZF1H103Z	C CERA	50V F 0.01MF Z	
C860	CCZF1H103Z	C CERA	50V F 0.01MF Z		CY39	CCZF1H103Z	C CERA	50V F 0.01MF Z	
C861	CCZF1H103Z	C CERA	50V F 0.01MF Z		CY41	CCZF1H103Z	C CERA	50V F 0.01MF Z	
C904	CBZR1C152M	C CERA	16V Y5R 1500PF M (AXIAL)		CY46	CCZF1H103Z	C CERA	50V F 0.01MF Z	
CA04	CCZB1H102K	C CERA	50V B 1000PF K (AXIAL)		CY47	CCZF1H473Z	C CERA	50V F 0.047MF Z (AXIAL)	
CN01	CBZF1H104Z	C CERA SEMI	50V F 0.1MF Z		CY48	CCZF1H103Z	C CERA	50V F 0.01MF Z	
CN02	CCZF1H103Z	C CERA	50V F 0.01MF Z		CY49	CCZF1H103Z	C CERA	50V F 0.01MF Z	
CN03	CCZF1H103Z	C CERA	50V F 0.01MF Z		CY54	CCZF1H103Z	C CERA	50V F 0.01MF Z	
CN04	CCZF1H103Z	C CERA	50V F 0.01MF Z		CY60	CBZF1H104Z	C CERA SEMI	50V F 0.1MF Z	
CN06	CCZF1H103Z	C CERA	50V F 0.01MF Z		D120	DUZ5R1B---	DIODE ZENER	UZ-5.1B	
CN07	CCZF1H103Z	C CERA	50V F 0.01MF Z		D502	D1N4148---	DIODE	1N4148 (TAPPING)	
CN14	CBZF1H104Z	C CERA SEMI	50V F 0.1MF Z		D503	D1N4148---	DIODE	1N4148 (TAPPING)	
CN16	CCZF1H103Z	C CERA	50V F 0.01MF Z		D504	D1N4148---	DIODE	1N4148 (TAPPING)	
CN17	CBZR1C222M	C CERA	16V Y5R 2200PF M (AXIAL)		D505	D1N4148---	DIODE	1N4148 (TAPPING)	
CN19	CCZF1H103Z	C CERA	50V F 0.01MF Z		D506	D1N4148---	DIODE	1N4148 (TAPPING)	
CN20	CCZB1H101K	C CERA	50V B 100PF K (AXIAL)		D507	D1N4148---	DIODE	1N4148 (TAPPING)	
CN21	CCZB1H101K	C CERA	50V B 100PF K (AXIAL)		D601	D1N4148---	DIODE	1N4148 (TAPPING)	
CN22	CCZB1H101K	C CERA	50V B 100PF K (AXIAL)		D602	D1N4148---	DIODE	1N4148 (TAPPING)	
CN23	CCZB1H102K	C CERA	50V B 1000PF K (AXIAL)		D603	D1N4148---	DIODE	1N4148 (TAPPING)	
CN24	CCZB1H102K	C CERA	50V B 1000PF K (AXIAL)		D701	D1N4148---	DIODE	1N4148 (TAPPING)	
CN25	CCZB1H102K	C CERA	50V B 1000PF K (AXIAL)		D703	D1N4148---	DIODE	1N4148 (TAPPING)	
CN30	CCZB1H102K	C CERA	50V B 1000PF K (AXIAL)		D705	D1N4148---	DIODE	1N4148 (TAPPING)	
CN32	CCZF1H223Z	C CERA	50V F 0.022MF Z		D706	D1N4148---	DIODE	1N4148 (TAPPING)	
CN80	CCZF1H223Z	C CERA	50V F 0.022MF Z		D707	D1N4148---	DIODE	1N4148 (TAPPING)	
CN81	CCZF1H103Z	C CERA	50V F 0.01MF Z		D708	D1N4148---	DIODE	1N4148 (TAPPING)	
CU06	CBZF1H104Z	C CERA SEMI	50V F 0.1MF Z		D709	D1N4004---	DIODE	1N4004	
CU08	CCZB1H102K	C CERA	50V B 1000PF K (AXIAL)		D710	D1N4148---	DIODE	1N4148 (TAPPING)	
CU09	CBZF1H104Z	C CERA SEMI	50V F 0.1MF Z		D711	DUZ2R4B---	DIODE ZENER	UZ-2.4B	
CU11	CCZF1H103Z	C CERA	50V F 0.01MF Z		D801	D1S1888---	DIODE	1S1888 (TAPPING)	
CU20	CCZF1H103Z	C CERA	50V F 0.01MF Z		D802	D1S1888---	DIODE	1S1888 (TAPPING)	
CU22	CBZF1H104Z	C CERA SEMI	50V F 0.1MF Z		D803	D1S1888---	DIODE	1S1888 (TAPPING)	
CU25	CBZF1H104Z	C CERA SEMI	50V F 0.1MF Z		D804	D1S1888---	DIODE	1S1888 (TAPPING)	

SERVICE PARTS LIST

LOC	PART CODE	PART NAME	DESCRIPTION	REMARK	LOC	PART CODE	PART NAME	DESCRIPTION	REMARK
D805	DBYV96E---	DIODE	BYV96E (TAPPING)		L802	5MC0000100	COIL BEAD	HC-3550	
D806	DUZ13BM---	DIODE ZENER	UZ-13BM		LA02	5CPZ100K04	COIL PEAKING	10UH 10.5MM K (LAL04TB)	
D807	D1N4937G--	DIODE	1N4937G (TAPPING)		LA03	5CPZ100K04	COIL PEAKING	10UH 10.5MM K (LAL04TB)	
D808	D1N4937G--	DIODE	1N4937G (TAPPING)		LU02	5CPZ680K02	COIL PEAKING	68UH K (AXIAL 3.5MM)	
D809	D1N4937G--	DIODE	1N4937G (TAPPING)		LU03	5CPZ101K04	COIL PEAKING	100UH K (AXIAL 10.5MM)	
D822	D1N4937G--	DIODE	1N4937G (TAPPING)		LY01	5CPZ560K02	COIL PEAKING	56UH K (AXIAL 3.5MM)	
D823	D1N4937G--	DIODE	1N4937G (TAPPING)		LY02	5CPZ101K04	COIL PEAKING	100UH K (AXIAL 10.5MM)	
D824	D1N4937G--	DIODE	1N4937G (TAPPING)		LY03	5CPZ101K04	COIL PEAKING	100UH K (AXIAL 10.5MM)	
D825	D1N4937G--	DIODE	1N4937G (TAPPING)		LY04	5CPZ101K04	COIL PEAKING	100UH K (AXIAL 10.5MM)	
D827	D1N4148---	DIODE	1N4148 (TAPPING)		LY05	5CPZ101K04	COIL PEAKING	100UH K (AXIAL 10.5MM)	
D828	D1N4937G--	DIODE	1N4937G (TAPPING)		LY06	5CPZ101K04	COIL PEAKING	100UH K (AXIAL 10.5MM)	
D831	D1N4148---	DIODE	1N4148 (TAPPING)		R101	RD-AZ101J-	R CARBON FILM	1/6 100 OHM J	
D832	DUZ5R6BM--	DIODE ZENER	UZ-5.6BM		R102	RD-AZ101J-	R CARBON FILM	1/6 100 OHM J	
D833	DUZ5R6BM--	DIODE ZENER	UZ-5.6BM		R103	RD-AZ472J-	R CARBON FILM	1/6 4.7K OHM J	
D839	D1N4004---	DIODE	1N4004		R104	RD-AZ392J-	R CARBON FILM	1/6 3.9K OHM J	
D841	D1N4148---	DIODE	1N4148 (TAPPING)		R501	RD-AZ472J-	R CARBON FILM	1/6 4.7K OHM J	
D846	D1N4148---	DIODE	1N4148 (TAPPING)		R502	RD-AZ561J-	R CARBON FILM	1/6 560 OHM J	
D847	D1N4148---	DIODE	1N4148 (TAPPING)		R503	RD-AZ101J-	R CARBON FILM	1/6 100 OHM J	
DA01	DUZ12BM---	DIODE ZENER	UZ-12BM (UNIZON)		R504	RD-AZ562J-	R CARBON FILM	1/6 5.6K OHM J	
DA02	DUZ6R2BM--	DIODE ZENER	UZ-6.2BM		R505	RD-AZ270J-	R CARBON FILM	1/6 27 OHM J	
DA03	DUZ6R2BM--	DIODE ZENER	UZ-6.2BM		R506	RD-AZ681J-	R CARBON FILM	1/6 680 OHM J	
DA04	DUZ6R2BM--	DIODE ZENER	UZ-6.2BM		R507	RD-4Z109J-	R CARBON FILM	1/4 1 OHM J	
DA05	DUZ6R2BM--	DIODE ZENER	UZ-6.2BM		R508	RD-AZ102J-	R CARBON FILM	1/6 1K OHM J	
DA06	DUZ6R2BM--	DIODE ZENER	UZ-6.2BM		R509	RD-AZ391J-	R CARBON FILM	1/6 390 OHM J	
DA07	DUZ6R2BM--	DIODE ZENER	UZ-6.2BM		R512	RD-AZ331J-	R CARBON FILM	1/6 330 OHM J	
DN01	D1N4004---	DIODE	1N4004		R513	RD-AZ101J-	R CARBON FILM	1/6 100 OHM J	
DN02	D1N4004---	DIODE	1N4004		R515	RD-AZ151J-	R CARBON FILM	1/6 150 OHM J	
DN04	D1N4148---	DIODE	1N4148 (TAPPING)		R516	RD-AZ154J-	R CARBON FILM	1/6 150K OHM J	
DN05	DUZ6R2BM--	DIODE ZENER	UZ-6.2BM		R517	RD-AZ390J-	R CARBON FILM	1/6 39 OHM J	
DN06	D1N4004---	DIODE	1N4004		R518	RD-AZ750J-	R CARBON FILM	1/6 75 OHM J	
DQ03	DUZ6R2BM--	DIODE ZENER	UZ-6.2BM		R525	RD-AZ822J-	R CARBON FILM	1/6 8.2K OHM J	
DQ04	DUZ6R2BM--	DIODE ZENER	UZ-6.2BM		R527	RD-4Z109J-	R CARBON FILM	1/4 1 OHM J	
DQ05	DUZ6R2BM--	DIODE ZENER	UZ-6.2BM		R528	RD-AZ102J-	R CARBON FILM	1/6 1K OHM J	
DQ07	D1N4148---	DIODE	1N4148 (TAPPING)		R530	RD-AZ393J-	R CARBON FILM	1/6 39K OHM J	
DU01	D1N4148---	DIODE	1N4148 (TAPPING)		R531	RD-AZ681J-	R CARBON FILM	1/6 680 OHM J	
DY01	D1N4148---	DIODE	1N4148 (TAPPING)		R532	RD-AZ513J-	R CARBON FILM	1/6 51K OHM J	
DY03	D1N4004---	DIODE	1N4004		R533	RD-AZ102J-	R CARBON FILM	1/6 1K OHM J	
L501	5CPZ100K02	COIL PEAKING	10UH K (AXIAL 3.5MM)		R534	RD-AZ102J-	R CARBON FILM	1/6 1K OHM J	
L502	5CPZ220K02	COIL PEAKING	22UH K (AXIAL 3.5MM)		R535	RD-AZ242J-	R CARBON FILM	1/6 2.4K OHM J	
L503	5CPZ150K02	COIL PEAKING	15UH K (AXIAL 3.5MM)		R536	RD-AZ151J-	R CARBON FILM	1/6 150 OHM J	
L602	5MC0000100	COIL BEAD	HC-3550		R539	RD-AZ102J-	R CARBON FILM	1/6 1K OHM J	
L603	5MC0000100	COIL BEAD	HC-3550		R540	RD-AZ303J-	R CARBON FILM	1/6 30K OHM J	
L605	5CPZ101K04	COIL PEAKING	100UH K (AXIAL 10.5MM)		R541	RD-AZ363J-	R CARBON FILM	1/6 36K OHM J	
L701	5CPZ220K02	COIL PEAKING	22UH K (AXIAL 3.5MM)		R545	RD-AZ102J-	R CARBON FILM	1/6 1K OHM J	
L702	5CPZ220K02	COIL PEAKING	22UH K (AXIAL 3.5MM)		R546	RD-AZ152J-	R CARBON FILM	1/6 1.5K OHM J	
L703	5CPZ220K02	COIL PEAKING	22UH K (AXIAL 3.5MM)		R547	RD-AZ102J-	R CARBON FILM	1/6 1K OHM J	
L705	5CPZ220K02	COIL PEAKING	22UH K (AXIAL 3.5MM)		R554	RD-AZ102J-	R CARBON FILM	1/6 1K OHM J	

SERVICE PARTS LIST

LOC	PART CODE	PART NAME	DESCRIPTION	REMARK	LOC	PART CODE	PART NAME	DESCRIPTION	REMARK
R555	RD-AZ331J-	R CARBON FILM	1/6 330 OHM J		R821	RD-4Z561J-	R CARBON FILM	1/4 560 OHM J	
R556	RD-AZ102J-	R CARBON FILM	1/6 1K OHM J		R822	RD-4Z153J-	R CARBON FILM	1/4 15K OHM J	
R557	RD-AZ103J-	R CARBON FILM	1/6 10K OHM J		R823	RD-AZ432J-	R CARBON FILM	1/6 4.3K OHM J	
R558	RD-AZ102J-	R CARBON FILM	1/6 1K OHM J		R824	RD-AZ332J-	R CARBON FILM	1/6 3.3K OHM J	
R559	RD-AZ242J-	R CARBON FILM	1/6 2.4K OHM J		R825	RD-AZ153J-	R CARBON FILM	1/6 15K OHM J	
R575	RD-AZ223J-	R CARBON FILM	1/6 22K OHM J		R826	RD-2Z222J-	R CARBON FILM	1/2 2.2K OHM J	
R601	RD-AZ392J-	R CARBON FILM	1/6 3.9K OHM J		R827	RD-4Z751J-	R CARBON FILM	1/4 750 OHM J	
R604	RD-AZ472J-	R CARBON FILM	1/6 4.7K OHM J		R828	RD-AZ473J-	R CARBON FILM	1/6 47K OHM J	
R605	RD-AZ472J-	R CARBON FILM	1/6 4.7K OHM J		R833	RD-4Z363J-	R CARBON FILM	1/4 36K OHM J	
R606	RD-AZ332J-	R CARBON FILM	1/6 3.3K OHM J		R834	RD-AZ473J-	R CARBON FILM	1/6 47K OHM J	
R607	RD-AZ223J-	R CARBON FILM	1/6 22K OHM J		R835	RD-AZ363J-	R CARBON FILM	1/6 36K OHM J	
R610	RD-AZ102J-	R CARBON FILM	1/6 1K OHM J		R847	RD-AZ104J-	R CARBON FILM	1/6 100K OHM J	
R611	RD-AZ103J-	R CARBON FILM	1/6 10K OHM J		R848	RD-AZ473J-	R CARBON FILM	1/6 47K OHM J	
R612	RD-AZ103J-	R CARBON FILM	1/6 10K OHM J		R849	RD-AZ472J-	R CARBON FILM	1/6 4.7K OHM J	
R706	RD-AZ472J-	R CARBON FILM	1/6 4.7K OHM J		R852	RD-AZ472J-	R CARBON FILM	1/6 4.7K OHM J	
R707	RD-AZ182J-	R CARBON FILM	1/6 1.8K OHM J		R853	RD-AZ473J-	R CARBON FILM	1/6 47K OHM J	
R708	RD-AZ472J-	R CARBON FILM	1/6 4.7K OHM J		R854	RD-4Z121J-	R CARBON FILM	1/4 120 OHM J	
R709	RD-AZ472J-	R CARBON FILM	1/6 4.7K OHM J		R858	RD-4Z100J-	R CARBON FILM	1/4 10 OHM J	
R710	RD-AZ472J-	R CARBON FILM	1/6 4.7K OHM J		R861	RD-AZ104J-	R CARBON FILM	1/6 100K OHM J	
R716	RD-AZ102J-	R CARBON FILM	1/6 1K OHM J		R862	RD-AZ473J-	R CARBON FILM	1/6 47K OHM J	
R717	RD-AZ223J-	R CARBON FILM	1/6 22K OHM J		R863	RD-AZ472J-	R CARBON FILM	1/6 4.7K OHM J	
R718	RD-AZ102J-	R CARBON FILM	1/6 1K OHM J		R865	RD-AZ101J-	R CARBON FILM	1/6 100 OHM J	
R719	RD-AZ102J-	R CARBON FILM	1/6 1K OHM J		R901	RD-AZ102J-	R CARBON FILM	1/6 1K OHM J	
R720	RD-AZ680J-	R CARBON FILM	1/6 68 OHM J		R902	RD-AZ102J-	R CARBON FILM	1/6 1K OHM J	
R721	RD-AZ473J-	R CARBON FILM	1/6 47K OHM J		R903	RD-AZ102J-	R CARBON FILM	1/6 1K OHM J	
R730	RD-AZ103J-	R CARBON FILM	1/6 10K OHM J		R904	RD-AZ101J-	R CARBON FILM	1/6 100 OHM J	
R731	RD-AZ103J-	R CARBON FILM	1/6 10K OHM J		R905	RD-AZ101J-	R CARBON FILM	1/6 100 OHM J	
R735	RD-AZ151J-	R CARBON FILM	1/6 150 OHM J		R906	RD-AZ101J-	R CARBON FILM	1/6 100 OHM J	
R736	RD-AZ472J-	R CARBON FILM	1/6 4.7K OHM J		RA09	RD-AZ822J-	R CARBON FILM	1/6 8.2K OHM J	
R737	RD-AZ151J-	R CARBON FILM	1/6 150 OHM J		RA10	RD-AZ392J-	R CARBON FILM	1/6 3.9K OHM J	
R739	RD-AZ151J-	R CARBON FILM	1/6 150 OHM J		RA20	RD-AZ750J-	R CARBON FILM	1/6 75 OHM J	
R741	RD-AZ102J-	R CARBON FILM	1/6 1K OHM J		RA39	RD-4Z430J-	R CARBON FILM	1/4 43 OHM J	
R742	RD-AZ103J-	R CARBON FILM	1/6 10K OHM J		RA44	RD-AZ471J-	R CARBON FILM	1/6 470 OHM J	
R747	RD-AZ101J-	R CARBON FILM	1/6 100 OHM J		RA45	RD-AZ221J-	R CARBON FILM	1/6 220 OHM J	
R748	RD-AZ103J-	R CARBON FILM	1/6 10K OHM J		RA46	RD-AZ221J-	R CARBON FILM	1/6 220 OHM J	
R749	RD-AZ103J-	R CARBON FILM	1/6 10K OHM J		RA47	RD-AZ223J-	R CARBON FILM	1/6 22K OHM J	
R751	RD-AZ472J-	R CARBON FILM	1/6 4.7K OHM J		RA48	RD-AZ471J-	R CARBON FILM	1/6 470 OHM J	
R752	RD-AZ272J-	R CARBON FILM	1/6 2.7K OHM J		RA49	RD-AZ221J-	R CARBON FILM	1/6 220 OHM J	
R790	RD-AZ393J-	R CARBON FILM	1/6 39K OHM J		RA50	RD-AZ471J-	R CARBON FILM	1/6 470 OHM J	
R804	RD-2Z474J-	R CARBON FILM	1/2 470K OHM J		RA51	RD-4Z101J-	R CARBON FILM	1/4 100 OHM J	
R805	RD-2Z470J-	R CARBON FILM	1/2 47 OHM J		RA52	RD-AZ103J-	R CARBON FILM	1/6 10K OHM J	
R806	RD-4Z473J-	R CARBON FILM	1/4 47K OHM J		RN01	RD-AZ472J-	R CARBON FILM	1/6 4.7K OHM J	
R807	RD-4Z470J-	R CARBON FILM	1/4 47 OHM J		RN02	RD-AZ332J-	R CARBON FILM	1/6 3.3K OHM J	
R808	RD-4Z102J-	R CARBON FILM	1/4 1K OHM J		RN03	RD-AZ182J-	R CARBON FILM	1/6 1.8K OHM J	
R810	RD-4Z362J-	R CARBON FILM	1/4 3.6K OHM J		RN04	RD-AZ474J-	R CARBON FILM	1/6 470K OHM J	
R811	RC-2Z565KP	R CARBON COMP	1/2 5.6M OHM K	⚠	RN05	RD-4Z151J-	R CARBON FILM	1/4 150 OHM J	
R812	RD-AZ472J-	R CARBON FILM	1/6 4.7K OHM J		RN06	RD-AZ304J-	R CARBON FILM	1/6 300K OHM J	

SERVICE PARTS LIST

LOC	PART CODE	PART NAME	DESCRIPTION	REMARK	LOC	PART CODE	PART NAME	DESCRIPTION	REMARK
RN07	RD-AZ472J-	R CARBON FILM	1/6 4.7K OHM J		RQ16	RD-AZ271J-	R CARBON FILM	1/6 270 OHM J	
RN08	RD-AZ221J-	R CARBON FILM	1/6 220 OHM J		RQ18	RD-AZ431J-	R CARBON FILM	1/6 430 OHM J	
RN09	RD-AZ153J-	R CARBON FILM	1/6 15K OHM J		RQ19	RD-AZ821J-	R CARBON FILM	1/6 820 OHM J	
RN10	RD-AZ332J-	R CARBON FILM	1/6 3.3K OHM J		RQ20	RD-AZ202J-	R CARBON FILM	1/6 2K OHM J	
RN11	RD-AZ103J-	R CARBON FILM	1/6 10K OHM J		RU01	RD-AZ751J-	R CARBON FILM	1/6 750 OHM J	
RN12	RD-AZ103J-	R CARBON FILM	1/6 10K OHM J		RU02	RD-AZ152J-	R CARBON FILM	1/6 1.5K OHM J	
RN13	RD-AZ103J-	R CARBON FILM	1/6 10K OHM J		RU05	RD-AZ201J-	R CARBON FILM	1/6 200 OHM J	
RN14	RD-AZ221J-	R CARBON FILM	1/6 220 OHM J		RU06	RD-AZ392J-	R CARBON FILM	1/6 3.9K OHM J	
RN15	RD-AZ472J-	R CARBON FILM	1/6 4.7K OHM J		RU07	RD-AZ272J-	R CARBON FILM	1/6 2.7K OHM J	
RN16	RD-AZ472J-	R CARBON FILM	1/6 4.7K OHM J		RU08	RD-AZ103J-	R CARBON FILM	1/6 10K OHM J	
RN17	RD-AZ472J-	R CARBON FILM	1/6 4.7K OHM J		RU09	RD-AZ512J-	R CARBON FILM	1/6 5.1K OHM J	
RN18	RD-AZ472J-	R CARBON FILM	1/6 4.7K OHM J		RU10	RD-AZ682J-	R CARBON FILM	1/6 6.8K OHM J	
RN19	RD-AZ182J-	R CARBON FILM	1/6 1.8K OHM J		RU11	RD-AZ821J-	R CARBON FILM	1/6 820 OHM J	
RN20	RD-AZ182J-	R CARBON FILM	1/6 1.8K OHM J		RU12	RD-AZ123J-	R CARBON FILM	1/6 12K OHM J	
RN21	RD-AZ103J-	R CARBON FILM	1/6 10K OHM J		RU13	RD-AZ223J-	R CARBON FILM	1/6 22K OHM J	
RN24	RD-AZ223J-	R CARBON FILM	1/6 22K OHM J		RU14	RD-AZ822J-	R CARBON FILM	1/6 8.2K OHM J	
RN27	RD-AZ472J-	R CARBON FILM	1/6 4.7K OHM J		RU15	RD-AZ123J-	R CARBON FILM	1/6 12K OHM J	
RN28	RD-AZ472J-	R CARBON FILM	1/6 4.7K OHM J		RU16	RD-AZ334J-	R CARBON FILM	1/6 330K OHM J	
RN29	RD-AZ332J-	R CARBON FILM	1/6 3.3K OHM J		RU17	RD-AZ151J-	R CARBON FILM	1/6 150 OHM J	
RN31	RD-AZ102J-	R CARBON FILM	1/6 1K OHM J		RU18	RD-AZ333J-	R CARBON FILM	1/6 33K OHM J	
RN32	RD-AZ102J-	R CARBON FILM	1/6 1K OHM J		RU19	RD-AZ102J-	R CARBON FILM	1/6 1K OHM J	
RN33	RD-AZ102J-	R CARBON FILM	1/6 1K OHM J		RU20	RD-AZ229J-	R CARBON FILM	1/6 2.2 OHM J	
RN34	RD-AZ221J-	R CARBON FILM	1/6 220 OHM J		RU21	RD-AZ229J-	R CARBON FILM	1/6 2.2 OHM J	
RN35	RD-AZ273J-	R CARBON FILM	1/6 27K OHM J		RU22	RD-AZ152J-	R CARBON FILM	1/6 1.5K OHM J	
RN36	RD-AZ221J-	R CARBON FILM	1/6 220 OHM J		RU23	RD-AZ470J-	R CARBON FILM	1/6 47 OHM J	
RN37	RD-AZ273J-	R CARBON FILM	1/6 27K OHM J		RU24	RD-AZ223J-	R CARBON FILM	1/6 22K OHM J	
RN38	RD-AZ182J-	R CARBON FILM	1/6 1.8K OHM J		RU25	RD-AZ103J-	R CARBON FILM	1/6 10K OHM J	
RN39	RD-AZ103J-	R CARBON FILM	1/6 10K OHM J		RU26	RD-AZ103J-	R CARBON FILM	1/6 10K OHM J	
RN40	RD-AZ103J-	R CARBON FILM	1/6 10K OHM J		RU27	RD-AZ103J-	R CARBON FILM	1/6 10K OHM J	
RN41	RD-AZ332J-	R CARBON FILM	1/6 3.3K OHM J		RU28	RD-AZ561J-	R CARBON FILM	1/6 560 OHM J	
RN42	RD-AZ103J-	R CARBON FILM	1/6 10K OHM J		RU29	RD-AZ433J-	R CARBON FILM	1/6 43K OHM J	
RN43	RD-AZ103J-	R CARBON FILM	1/6 10K OHM J		RU30	RD-AZ332J-	R CARBON FILM	1/6 3.3K OHM J	
RN44	RD-AZ333J-	R CARBON FILM	1/6 33K OHM J		RU31	RD-AZ225J-	R CARBON FILM	1/6 2.2M OHM J	
RN45	RD-AZ103J-	R CARBON FILM	1/6 10K OHM J		RU32	RD-AZ563J-	R CARBON FILM	1/6 56K OHM J	
RN46	RD-AZ472J-	R CARBON FILM	1/6 4.7K OHM J		RU33	RD-AZ332J-	R CARBON FILM	1/6 3.3K OHM J	
RN47	RD-AZ474J-	R CARBON FILM	1/6 470K OHM J		RY01	RD-AZ243J-	R CARBON FILM	1/6 24K OHM J	
RN48	RD-AZ101J-	R CARBON FILM	1/6 100 OHM J		RY02	RD-AZ103J-	R CARBON FILM	1/6 10K OHM J	
RN49	RD-AZ101J-	R CARBON FILM	1/6 100 OHM J		RY03	RD-AZ183J-	R CARBON FILM	1/6 18K OHM J	
RQ02	RD-AZ222J-	R CARBON FILM	1/6 2.2K OHM J		RY04	RD-AZ223J-	R CARBON FILM	1/6 22K OHM J	
RQ03	RD-AZ222J-	R CARBON FILM	1/6 2.2K OHM J		RY05	RD-AZ103J-	R CARBON FILM	1/6 10K OHM J	
RQ05	RN-AZ1001F	R METAL FILM	1/6 1K OHM F		RY06	RD-AZ102J-	R CARBON FILM	1/6 1K OHM J	
RQ06	RN-AZ1001F	R METAL FILM	1/6 1K OHM F		RY07	RD-AZ331J-	R CARBON FILM	1/6 330 OHM J	
RQ07	RD-AZ181J-	R CARBON FILM	1/6 180 OHM J		RY08	RD-AZ331J-	R CARBON FILM	1/6 330 OHM J	
RQ08	RD-AZ181J-	R CARBON FILM	1/6 180 OHM J		RY09	RD-AZ272J-	R CARBON FILM	1/6 2.7K OHM J	
RQ10	RD-AZ271J-	R CARBON FILM	1/6 270 OHM J		RY10	RD-AZ201J-	R CARBON FILM	1/6 200 OHM J	
RQ11	RD-AZ431J-	R CARBON FILM	1/6 430 OHM J		RY11	RD-AZ561J-	R CARBON FILM	1/6 560 OHM J	
RQ12	RD-AZ821J-	R CARBON FILM	1/6 820 OHM J		RY12	RD-AZ561J-	R CARBON FILM	1/6 560 OHM J	
RQ13	RD-AZ202J-	R CARBON FILM	1/6 2K OHM J		RY13	RD-AZ152J-	R CARBON FILM	1/6 1.5K OHM J	

SERVICE PARTS LIST

LOC	PART CODE	PART NAME	DESCRIPTION	REMARK	LOC	PART CODE	PART NAME	DESCRIPTION	REMARK
RY14	RD-AZ472J-	R CARBON FILM	1/6 4.7K OHM J		E005	4856310300	EYE LET	BSR T0.2 (R1.6)	
RY15	RD-AZ102J-	R CARBON FILM	1/6 1K OHM J		E006	4856310300	EYE LET	BSR T0.2 (R1.6)	
RY16	RD-AZ102J-	R CARBON FILM	1/6 1K OHM J		E007	4856310600	EYE LET	BSR T0.2 (R2.3)	
RY17	RD-AZ221J-	R CARBON FILM	1/6 220 OHM J		E008	4856310600	EYE LET	BSR T0.2 (R2.3)	
RY19	RD-AZ820J-	R CARBON FILM	1/6 82 OHM J		E009	4856310600	EYE LET	BSR T0.2 (R2.3)	
RY20	RD-AZ750J-	R CARBON FILM	1/6 75 OHM J		E010	4856310600	EYE LET	BSR T0.2 (R2.3)	
RY23	RD-AZ392J-	R CARBON FILM	1/6 3.9K OHM J		E011	4856310600	EYE LET	BSR T0.2 (R2.3)	
RY24	RD-AZ102J-	R CARBON FILM	1/6 1K OHM J		E012	4856310600	EYE LET	BSR T0.2 (R2.3)	
RY25	RD-AZ272J-	R CARBON FILM	1/6 2.7K OHM J		E013	4856310600	EYE LET	BSR T0.2 (R2.3)	
RY26	RD-AZ182J-	R CARBON FILM	1/6 1.8K OHM J		E014	4856310600	EYE LET	BSR T0.2 (R2.3)	
RY27	RD-AZ822J-	R CARBON FILM	1/6 8.2K OHM J		E015	4856310600	EYE LET	BSR T0.2 (R2.3)	
RY28	RD-AZ182J-	R CARBON FILM	1/6 1.8K OHM J		R401	RS01Z209J-	R M-OXIDE FILM	1W 2 OHM J	⚠
RY29	RD-AZ103J-	R CARBON FILM	1/6 10K OHM J		ZZ200	PTPWJRA643	PCB POWER RADIAL AS	DVT-14H1F	
RY30	RD-AZ103J-	R CARBON FILM	1/6 10K OHM J		C303	CBXF1H104Z	C CERA SEMI	50V F 0.1MF Z (TAPPING)	
RY31	RD-AZ221J-	R CARBON FILM	1/6 220 OHM J		C311	CEXF1E471V	C ELECTRO	25V RSS 470MF (10X16) TP	
RY32	RD-AZ102J-	R CARBON FILM	1/6 1K OHM J		C312	CBXF1H104Z	C CERA SEMI	50V F 0.1MF Z (TAPPING)	
RY33	RD-AZ472J-	R CARBON FILM	1/6 4.7K OHM J		C313	CMXM2A104J	C MYLAR	100V 0.1MF J (TP)	
RY52	RD-AZ103J-	R CARBON FILM	1/6 10K OHM J		C314	CMXM2A473J	C MYLAR	100V 0.047MF J (TP)	
RY53	RD-AZ363J-	R CARBON FILM	1/6 36K OHM J		C315	CMXM2A473J	C MYLAR	100V 0.047MF J (TP)	
RY54	RD-AZ473J-	R CARBON FILM	1/6 47K OHM J		C316	CMXM2A104J	C MYLAR	100V 0.1MF J (TP)	
RY55	RD-AZ393J-	R CARBON FILM	1/6 39K OHM J		C317	CMXM2A103J	C MYLAR	100V 0.01MF J (TP)	
RY56	RD-AZ302J-	R CARBON FILM	1/6 3K OHM J		C403	CCXB2H221K	C CERA	500V B 220PF K (TAPPING)	
RY57	RD-AZ473J-	R CARBON FILM	1/6 47K OHM J		C411	CCXB2H222K	C CERA	500V B 2200PF K (TAPPING)	
RY58	RD-AZ473J-	R CARBON FILM	1/6 47K OHM J		C412	CMXM2A104J	C MYLAR	100V 0.1MF J (TP)	
ZZ400	PTPWMSA643	PCB POWER MANUAL AS	DVT-14H1F		C419	CEXF2C339V	C ELECTRO	160V RSS 3.3MF (8X16) TP	
C418	CMYE2D624J	C MYLAR	200V PU 0.62MF J	⚠	C424	CMXM2A104J	C MYLAR	100V 0.1MF J (TP)	
C426	CMYH3C722J	C MYLAR	1.6KV BUP 7200PF J	⚠	C433	CXSL2H470J	C CERA	500V SL 47PF J (TAPPING)	
D424	DDG3-----	DIODE	DG3		L402	58CX430599	COIL CHOKE	AZ-9004Y 940K TP	
I301	PTA2SW8201	HEAT SINK ASS'Y	ITDA8357- + 7174301000		Q402	T2SD1207T-	TR	2SD1207-T (TAPPING)	⚠
1	1TDA8357J-	IC VERTICAL	TDA8357J	Ⓜ	R318	RN02B331JS	R METAL FILM	2W 330 OHM J SMALL	
0000A	4857028201	HEAT SINK	AL EX		R417	RN02B103JS	R METAL FILM	2W 10K OHM J SMALL	
0000B	7174301011	SCREW TAPPTITE	TT2 RND 3X10 MFZN		R424	RN02B101JS	R METAL FILM	2W 100 OHM J SMALL	
M382	4853817900	FRAME SUB PCB	FR HIPS BK		R425	RN02B101JS	R METAL FILM	2W 100 OHM J SMALL	
M382A	7178301011	SCREW TAPPTITE	TT2 WAS 3X10 MFZN		ZZ200	PTPWJAA643	PCB POWER AXIAL AS	DVT-14H1F	
M382B	7172401412	SCREW TAPPTITE	TT2 TRS 4X14 MFZN BK		10	2TM14006LB	TAPE MASKING	3M #232 6.0X2000M	
P403	4859240020	CONN WAFER	YFW500-05		20	2TM10006LB	TAPE MASKING	3M #232-MAP-C 6.2X2000M	
P807	4859235320	CONN WAFER	YW025-10		A001	4859813211	PCB POWER	330X246	
PA904	4850703S19	CONNECTOR	YH025-03+YST025+ULW=300		D301	DUZ30BL---	DIODE ZENER	UZ-30BL	
Q401	T2SD2499--	TR	2SD2499	⚠	D302	DUZ30BL---	DIODE ZENER	UZ-30BL	
T401	50D10A2---	TRANS DRIVE	TD-10A2	⚠	D311	D1N4004---	DIODE	1N4004	
T402	50H000177	FBT	HST1142.5057	⚠	D312	DUZ12BM---	DIODE ZENER	UZ-12BM (UNIZON)	
ZZ200	PTPWJ0A643	PCB POWER ODD SHAPE	DVT-14H1F		D413	D1N4937G--	DIODE	1N4937G (TAPPING)	
C421	CEXF2C470V	C ELECTRO	160V RSS 47MF (13X25) TP		D421	D1N4937G--	DIODE	1N4937G (TAPPING)	
C423	CEXF2E100V	C ELECTRO	250V RSS 10MF (10X20) TP		D422	D1N4937G--	DIODE	1N4937G (TAPPING)	
ZZ200	PTPWJBA643	PCB POWER M-10 AS	DVT-14H1F		D423	D1N4937G--	DIODE	1N4937G (TAPPING)	
E003	4856310300	EYE LET	BSR T0.2 (R1.6)		L301	5CPZ100K04	COIL PEAKING	10UH 10.5MM K (LAL04TB)	
E004	4856310300	EYE LET	BSR T0.2 (R1.6)		L302	5CPZ100K04	COIL PEAKING	10UH 10.5MM K (LAL04TB)	

SERVICE PARTS LIST

LOC	PART CODE	PART NAME	DESCRIPTION	REMARK	LOC	PART CODE	PART NAME	DESCRIPTION	REMARK
L311	5CPZ109M04	COIL PEAKING	1UH 10.5MM M (LAL04TB)		R320	RD-4Z473J-	R CARBON FILM	1/4 47K OHM J	
R301	RD-4Z101J-	R CARBON FILM	1/4 100 OHM J		R405	RD-4Z152J-	R CARBON FILM	1/4 1.5K OHM J	
R302	RD-4Z101J-	R CARBON FILM	1/4 100 OHM J		R412	RD-4Z272J-	R CARBON FILM	1/4 2.7K OHM J	
R311	RD-AZ152J-	R CARBON FILM	1/6 1.5K OHM J		R413	RD-4Z399J-	R CARBON FILM	1/4 3.9 OHM J	
R312	RD-AZ152J-	R CARBON FILM	1/6 1.5K OHM J		R419	RD-4Z273J-	R CARBON FILM	1/4 27K OHM J	
R315	RD-4Z562J-	R CARBON FILM	1/4 5.6K OHM J		R421	RD-2Z224J-	R CARBON FILM	1/2 220K OHM J	
R316	RD-4Z272J-	R CARBON FILM	1/4 2.7K OHM J		R422	RD-4Z102J-	R CARBON FILM	1/4 1K OHM J	
R317	RD-AZ564J-	R CARBON FILM	1/6 560K OHM J		R423	RD-4Z303J-	R CARBON FILM	1/4 30K OHM J	
R319	RD-2Z159J-	R CARBON FILM	1/2 1.5 OHM J						

THE DIFFERENT PARTS LIST FOR SIZE

LOC.	PART NAME	PART CODE	PART TYPE	DVT-14H1F	DVT-20H1F
20	ANT ROD	4850A03310	PH-RM-008A	○	
C418	C MYLAR	CMYE2D684J	200V PU 0.68MF J		○
		CMYE2D624J	200V PU 0.62MF J	○	
CRT1	CRT AS	PTRTPWA643	DVT-14H1F	○	
		PTRTPWD353	DVT-20H1F		○
M191	BUTTON CTRL	4851936700	4941901+5536500	○	
		4851936800	4942001+5538301		○
M201	MASK FRONT	4852070021	HIPS BK	○	
		4852070121	HIPS BK		○
M211	COVER BACK	4852153021	HIPS BK	○	
		4852153701	HIPS BK		○
M211A	SCREW TAPPTITE	7122401612	T2S TRS 4X16 MFZN BK		○
		7172401612	TT2 TRS 4X16 MFZN BK	○	
M281	DOOR F/L	4852817701	ABS BK		○
		4852817720	ABS BK SILK	○	
M381A	SCREW TAPPTITE	7178301011	TT2 WAS 3X10 MFZN		○
		7178301212	TT2 WAS 3X12 MFZN BK	○	
M481	BUTTON POWER	4854854601	ABS BK	○	
		4854854701	ABS BK		○
M482	BUTTON POWER A	4854858401	ABS BK	○	
		4854858601	ABS BK		○
M561	MARK BRAND	4855613600	COPPER T0.4	○	
		48556159SS	SILVER ETCHING DIA-CUT		○
M782	CLOTH BLACK	4857817630	FELT 400X20X0.7		○
		4857817640	FELT 100X20X0.7	○	
M801	BOX CARTON	4858038300	DW-3 2086		○
		4858042700	SW-3	○	
M811	PAD	4858189400	EPS 14H1	○	
		4858189500	EPS 20H1		○
M822	BAG P.E	4858215000	PE FOAM 10.5x1200x1150		○
		4858215700	PE FOAM 10.5x1000x950	○	
PA601	CONNECTOR	4850703S51	YH025-03+35098+ULW=300	○	
		4850703S54	YH025-03+35098+ULW=600		○
R401	R M-OXIDE FILM	RS01Z209J-	1W 2 OHM J	○	
		RS01Z309J-	1W 3 OHM J (TAPPING)		○
R525	R CARBON FILM	RD-AZ622J-	1/6 6.2K OHM J		○
		RD-AZ822J-	1/6 8.2K OHM J	○	
R575	R CARBON FILM	RD-AZ183J-	1/6 18K OHM J		○
		RD-AZ223J-	1/6 22K OHM J	○	
R801	POSISTOR	DEC140M290	ECPC140M290	○	
		DPC7R0M290	2322 662 96709		○

SERVICE PARTS LIST

LOC.	PART NAME	PART CODE	PART TYPE	DVT-14H1F	DVT-20H1F
SP01	SPEAKER	4858314310	SP-5070A01 3W 8 OHM	○	
		48A8306000	SS-5070A01 3W 8 OHM		○
SP01A	SCREW SPKR FIX	4856013600	SWRM+SECC		○
V01	COIL DY	58D1000045	ODY-M2002		○
		58D1000046	ODY-M1401	○	
V901	CRT BARE	48A96414P1	A34JLL90X	○	
		48A96420P1	A48JLL90X(W)		○
ZZ110	ACCESSORY AS	PTACPWA643	DVT-14H1F	○	
		PTACPWD353	DVT-20H1F		○
ZZ120	COVER BACK AS	PTBCSHA643	DVT-14H1F	○	
		PTBCSHD353	DVT-20H1F		○
ZZ130	PACKING AS	PTPKCPA643	DVT-14H1F	○	
		PTPKCPD353	DVT-20H1F		○
ZZ131	CRT GROUND NET	48519A4710	1401S-1015-1P	○	
		48519A5110	2001S-1015-1P		○
ZZ132	COIL DEGAUSSING	58G0000084	DC-1450	○	
		58G0000146	DC-20SF		○
ZZ140	CABINET AS	PTCACA643	DVT-14H1F	○	
		PTCACAD353	DVT-20H1F		○
ZZ200	MASK FRONT AS	PTFMSJA643	DVT-14H1F	○	
		PTFMSJD353	DVT-20H1F		○
ZZ200	PCB MAIN (RHU) AS	PTMPJ0A643	DVT-14H1F	○	
		PTMPJ0D353	DVT-20H1F		○
ZZ200	PCB CHIP MOUNT B AS	PTMPJ2A643	DVT-14H1F	○	
		PTMPJ2D353	DVT-20H1F		○
ZZ200	PCB MAIN AXIAL AS	PTMPJAA643	DVT-14H1F	○	
		PTMPJAD353	DVT-20H1F		○
ZZ200	PCB MAIN RADIAL AS	PTMPJRA643	DVT-14H1F	○	
		PTMPJRD353	DVT-20H1F		○
ZZ200	PCB POWER ODD SHAPE	PTPWJ0A643	DVT-14H1F	○	
		PTPWJ0D353	DVT-20H1F		○
ZZ200	PCB POWER AXIAL AS	PTPWJAA643	DVT-14H1F	○	
		PTPWJAD353	DVT-20H1F		○
ZZ200	PCB POWER M-10 AS	PTPWJBA643	DVT-14H1F	○	
		PTPWJBD353	DVT-20H1F		○
ZZ200	PCB POWER RADIAL AS	PTPWJRA643	DVT-14H1F	○	
		PTPWJRD353	DVT-20H1F		○
ZZ210	SPEAKER AS	PTSPWA643	DVT-14H1F	○	
		PTSPWD353	DVT-20H1F		○
ZZ290	PCB MAIN MANUAL AS	PTMPMSA643	DVT-14H1F	○	
		PTMPMSD353	DVT-20H1F		○
ZZ400	PCB POWER MANUAL AS	PTPWMSA643	DVT-14H1F	○	
		PTPWMSD353	DVT-20H1F		○

THE DIFFERENT PARTS LIST FOR SYSTEM

LOC.	PART NAME	PAL B/G [F]	PAL I [P]	P/S-B/G,D/K [D]
SF501	FILTER SAW	G1966M	J1952M	K2950M
Z501	FILTER CERA	SFSH5.5MCB-TF21(TP)	SFSH6.0MCB-TF21(TP)	SFSH5.5MCB-TF21(TP)
Z503	FILTER CERA	TPS5.5MB-TF21	TPS6.0MB-TF21	TPS5.5MB-TF21
Z504	FILTER CERA	X	X	SFSH6.5MCB-TF21(TP)
Z502	FILTER CERA	X	X	TPS6.5MB-TF21
R553	R CARBON FILM	X	X	1/6 560 OHM J
C554	C CERA	X	X	50V B 150PF K AXIAL
PW000	CORD POWER	4859906111	4859905110	4859901111
PWC1	CORD POWER AS	PTWBSW7410	PTWASW5110	PTWASW2910
I501	IC VIDEO	TDA8841	TDA8841	TDA8842

THE DIFFERENT PARTS LIST FOR TELETEXT

LOC.	PART NAME	DVT-14H1F(WITHOUT TELETEXT)		DVT-14H1TF(WITH TELETEXT)	
		PART CODE	PART TYPE	PART CODE	PART TYPE
C550	C CERA	X	X	CCZF1H103Z	50V F 0.01MF Z
CC717	C CHIP CERA	X	X	HCBH224KCA	25V X7R 0.22MF K
I701	IC MICOM	1SDA555XFL	SDA555XFL	1SDA55	SDA5
J213	WIRE COPPER	X	X	85801065GY	AWG22 1/0.65 TIN COATING
J214	WIRE COPPER	X	X	85801065GY	AWG22 1/0.65 TIN COATING
J217	WIRE COPPER	X	X	85801065GY	AWG22 1/0.65 TIN COATING
J218	WIRE COPPER	X	X	85801065GY	AWG22 1/0.65 TIN COATING
QC507	TR CHIP	X	X	T2SC1623T2	2SC1623-L6/T2B
R103	R CARBON FILM	RD-AZ472J-	1/6 4.7K OHM J	X	X
R537	R CARBON FILM	X	X	RD-AZ103J-	1/6 10K OHM J
R542	R CARBON FILM	X	X	RD-AZ151J-	1/6 150 OHM J
RC538	R CHIP	X	X	HRFT470JCA	1/10 47 OHM J 2012
RC543	R CHIP	X	X	HRFT151JCA	1/10 150 OHM J 2012
RC782	R CHIP	X	X	HRFT105JCA	1/10 1M OHM J 2012

Video

1. Outline

This video circuit uses a LA71598SM Super A/V 1 chip IC made by SANYO which includes luminance and color processor, CCD and PREAMP.

This IC has 100 pin, but only 79 pin(10~74 pin and 81~94 pin) are related to Video circuit among them.

2.Video circuit

A. EE mode

1.0Vp-p video signal out of SCART JACK or CHROMA IC is input to pin 38,34, of ICY01.

One of them is selected, and input to AGC AMP(sync and peak AGC).

Output from AGC AMP is input to QV/QH insert circuit.

After it is amplified 6dB through Video Amp, 2.0Vp-p signal is output to pin 29.

Finally it is output through pin 17 of I501(TDA8841)

EE mode process

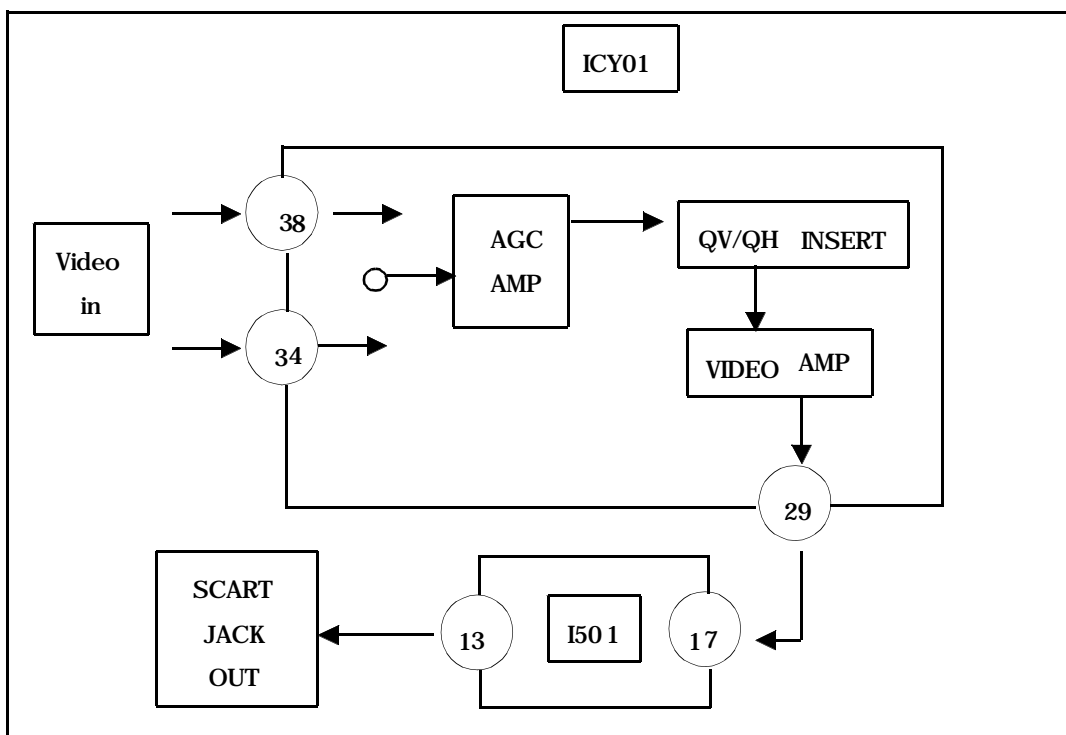

Fig . 1 EE mode process

B. REC mode

a) Luminance Signal Processing

The signal is to pin 38,34 of ICY01, and one is selected to input to AGC AMP.

This input signal performs sync AGC and peak AGC.

And then , it is input to the 6dB divider where its level is educed to 0.5V.

LPF and 1H Delay separates luminance signal from output signal of the divider.

The separated luminance signal is passed through pin 21, and it is input to pin 20.

The level is clamped in clamp circuit which fixes sync tip to a specific DC level in order to prevent

Frequency drift while video signal is converted to FM signal.

The edge of the signal is emphasized by Detail Enhancer.

The emphasized signal is supplied to Non-Linear Emphasis circuit to improve S/N ratio.

Non-Linear Emphasis circuit adjusts amount of emphasis in high frequency in LP mode,

which means that amount of emphasis is dependent on the input level, for instance, the lower input level, the large amount of emphasis.

Main emphasis emphasizes the high frequency of the adjusted signal again.

White/Dark clip is conducted in order to prevent the luminance signal from undershooting and overshooting which are occurred during the above emphasize process.

The luminance signal modulated by FM modulator is passed through REC-EQ, modulated Y signal is mixed with the down converted color signal.

It is supplied to AGC Amp of Pre-Amp section and then supplied to video head through Pin 84 in SP mode or LP mode.

b) Color Signal Process

The video signal input from pin 38,34 of ICY01 is passed through AGC AMP and BPF.

A color signal separated by 4.43MHz BPF.

This signal is supplied to Comb Filter, and separated color signal.

Then the signal goes to ACC section which automatically controls color burs level.

After Burst Emphasis boots burst signal 6dB, 4.43MHz carrier frequency is input to Main converter and mixed with 5.06MHz carrier frequency from sub-converter.

In the long run, the output is $5.06\text{MHz} \pm 4.43\text{MHz}$.

The down-converted 627KHz color signal, the difference between two frequencies, is passed through color LPF.

The output signal is mixed with modulated Y-FM signal and supplied to AGC part.

It is supplied to the head through pin 84 in SP mode or LP mode.

REC Luminance process

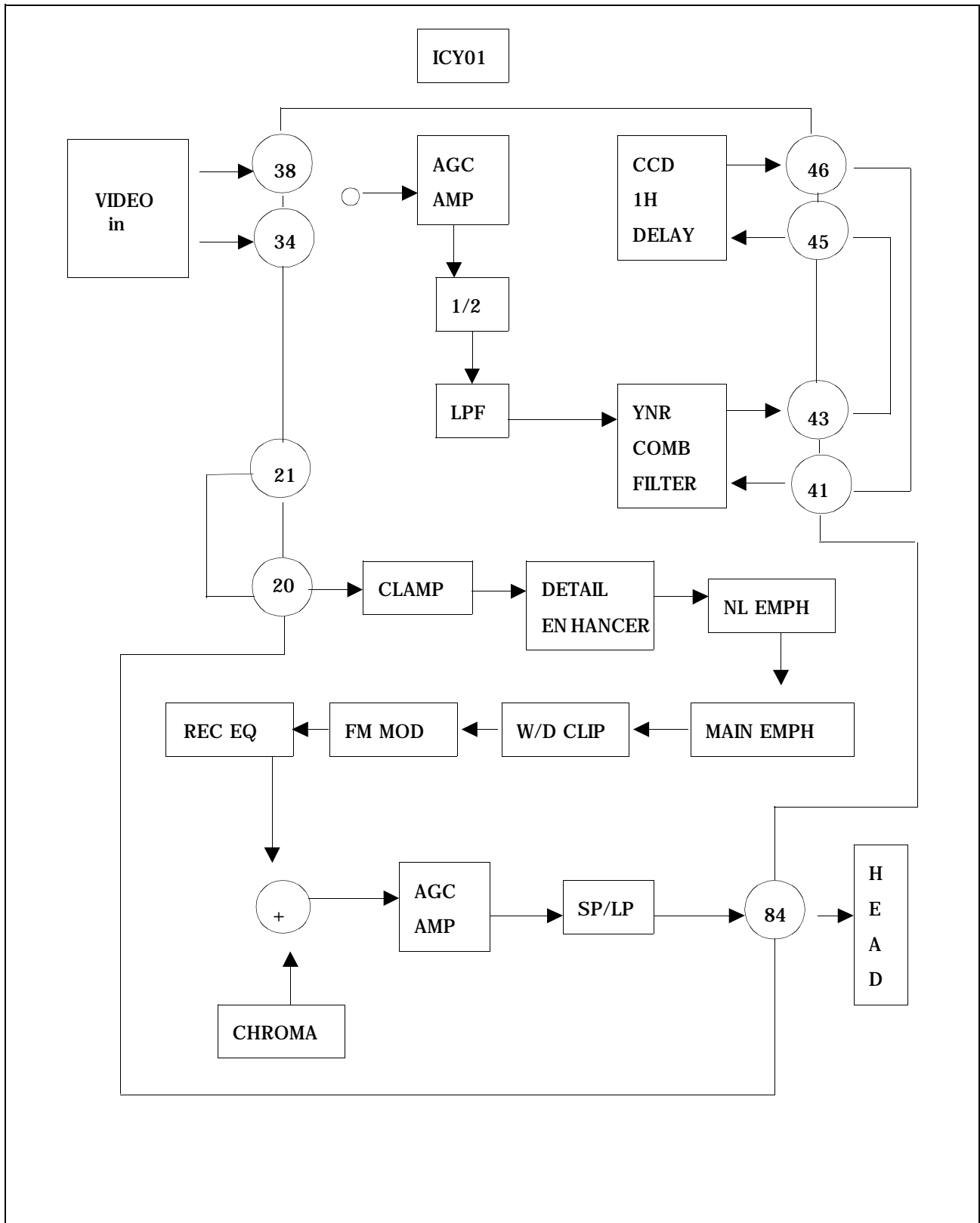

Fig. 2 REC Luminance Process

REC color process

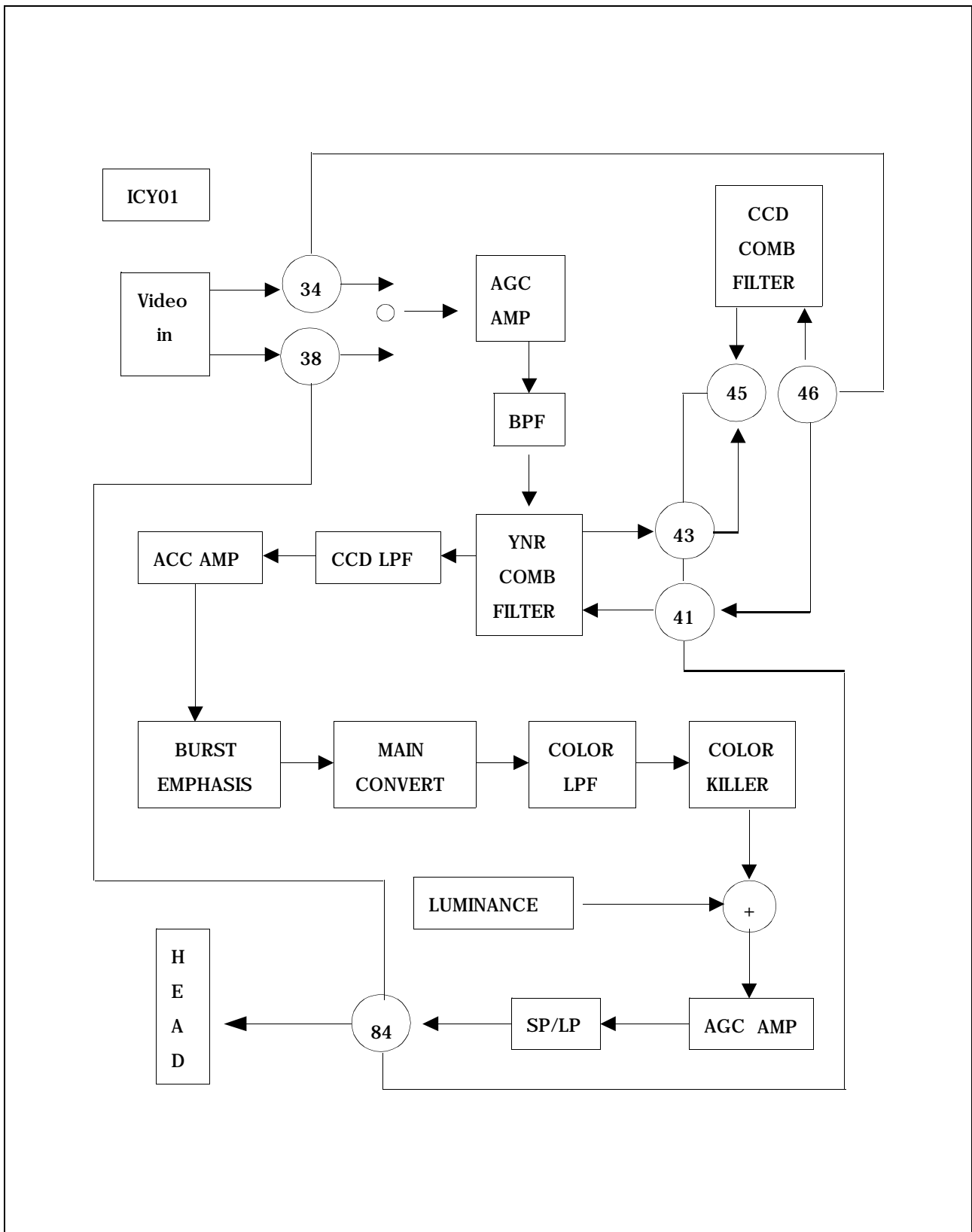

Fig . 3 REC color process

C. PB mode

a) Luminance Signal Processing

The recorded signal is picked up by the head, and amplified 60dB by PRE AMP part.

The amplified FM signal is supplied to FM AGC.

It is automatically controlled by FM AGC to adjust output tolerance of CH1 and CH2.

This signal is FM EQ and phase compensation

It is sent to Double Limiter circuit which removes AM noise, prevents over-modulation and lets the signal input to FM DEMOD.

The signal from FM DEMOD is fed to main de-emphasis through SUB LPF, and the boosted high frequency in REC mode is de-emphasized there, and input to pin 20 through pin 21.

After eliminating demodulation noise caused during the above processes by 3M LPF, it is input to YNR circuit.

The signal passing through YNR is supplied to non-linear emphasis circuit.

Non-linear de-emphasis plays a role quite opposed to Non-linear emphasis in record mode.

That is, it de-emphasized the high frequency level emphasized by Non-linear emphasis.

Double noise canceller reduces minute noise of video signal.

After being passed it is mixed with color signal.

The mixed signal is obtained pin 29, supplied to pin 17 of I501.

b) Color Signal Process

The 60dB amplified signal in PRE AMP goes to 1.3MHz LPF, which separates down converted color signal. And then it is supplied to AGC part.

ACC(Automatic Color Control) AMP stabilizes the color signal .

The stabilized signal is supplied to main converter and mixed with the 5.06MHz signal come from sub-converter. Its output is $5.06\text{MHz} \pm 27\text{KHz}$. The mixed signal is fed to 4.43MHz BPF in order to pass 4.43MHz color signal only. And it is supplied to Comb Filter.

During this process, cross-talk between adjacent tracks is eliminated..

The output signal from Comb Filter is supplied to Burst De-emphasis which reduces the 6dB boosted burst level (in REC mode, but not in LP mode).

This color signal is mixed with luminance signal, and mixed signal is output to pin 29 of ICY01 through Video AMP.

PB Luminance process

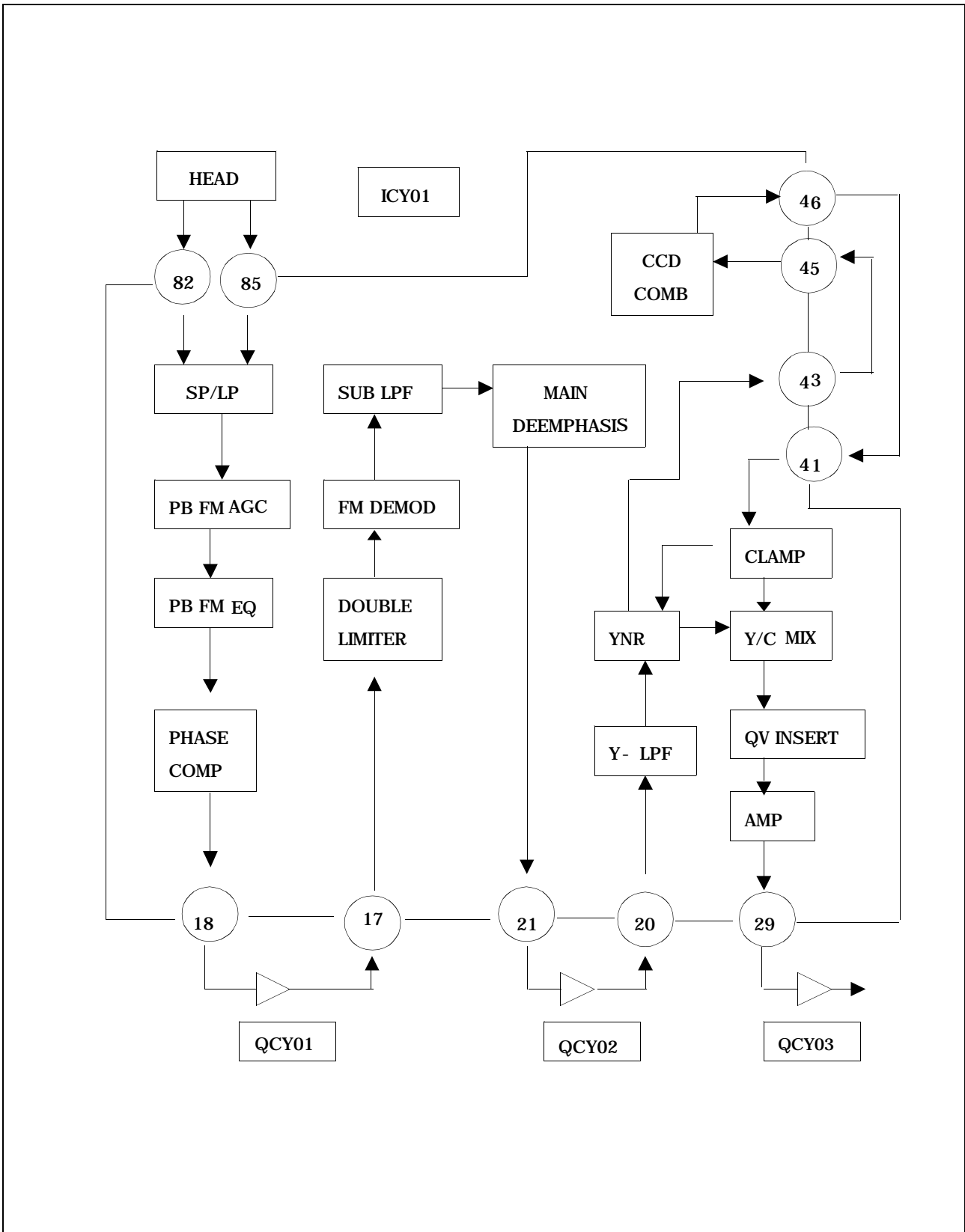

Fig .4 PB Luminance Process

PB color process

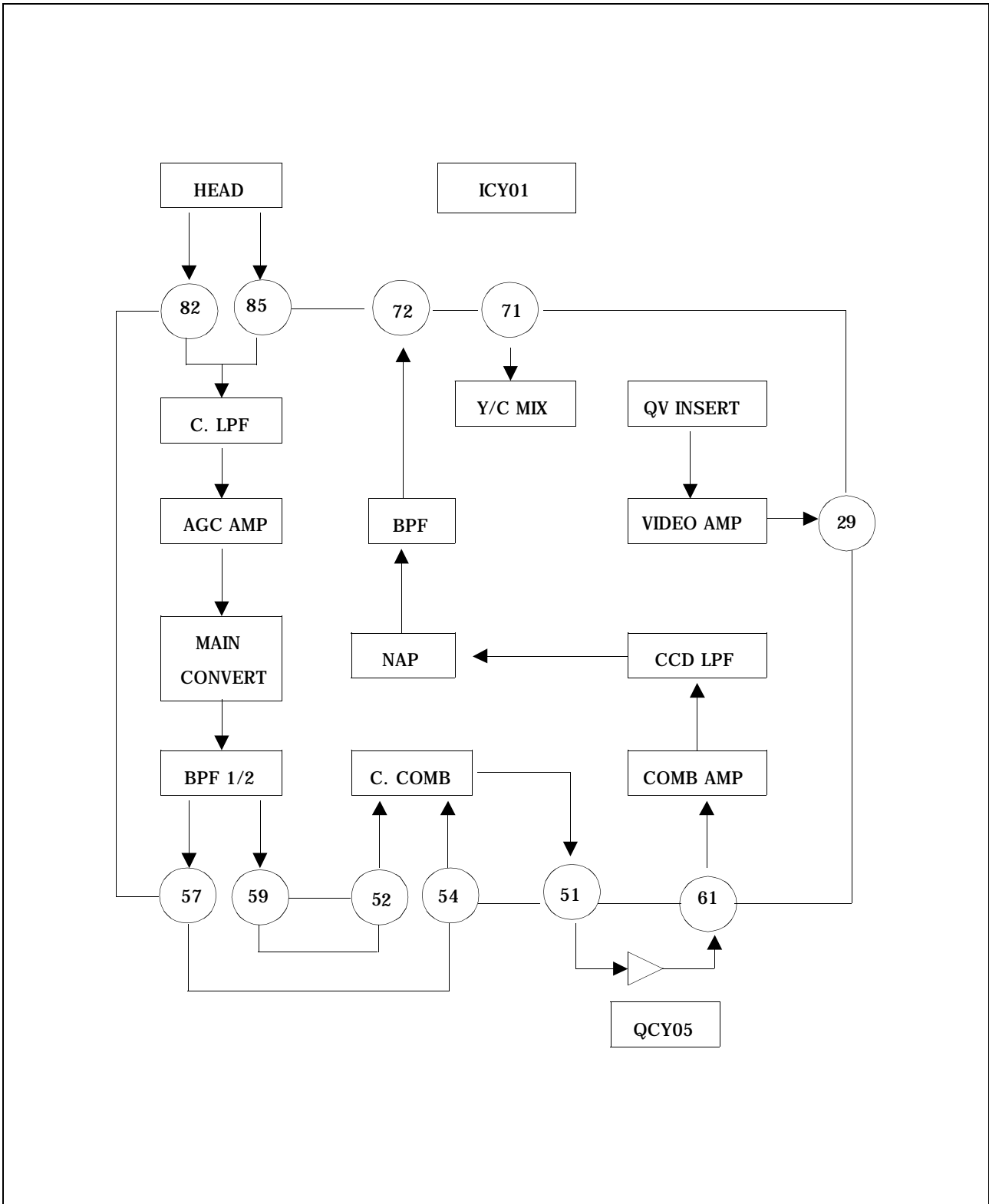

Fig . 5 PB Color Process

Linear Audio

1 Outline

This audio circuit uses a LA71598SM Super A/V 1 chip IC made by SANYO.

The major features of this IC is that REC/EE mode, PB/EE mode, SP/LP mode and audio input selection are controlled by parallel.

21 pin (1-9 pin, 75-80 pin, and 95-100 pin) are related to Audio circuit.

2 Audio IC : name and operation of pins

A. Features

Including PB Amp, Line Amp, REC Amp, ALC circuit, EQ switch and Auto REC bias circuit.

It is equipped with EQ switch operates in SP/LP mode respectively.

ALC level is fixed on 4dBm by values.

B. Function

Pin No.	Name	Function
1	EQ-OUT	Playback Amp output
2	EQ-SW2	Capacitor switch for head resonance: in SP or LP, SW ON
3	EQ-NFB	Negative feedback of PB Amp
4	EQ-IN	Input impedance : 120Kohm
5	EQ-SW1	Playback equalizer switch : in SLP mode, SW ON
6	AUTO-BIAS IN	70KHz signal input for auto-bias
7	AUDIO REC OUT	Recording Amp out
8	REC-NFB-SP(GND)	GND
9	REC-NFB-LP(GND)	GND
75	AUDIO VCC(5V)	Vcc (5V)
76	AUDIO-IN	Audio in
77	ALC-DET	Port for ALC Filter
78	AUDIO-IN2	Audio in
79	VREF	Vref filter
80	AUDIO-IN3	Audio in
95	AUDIO-GND	GND
96	AUDIO-LINE-OUT	Line Amp output
97	ALC-IN	ALC detect
98	AUDIO-REC-IN	Input to REC Amp
99	AUTO-BIAS-OUT	DC control voltage for auto-bias
100	AUDIO-PB-IN	Line Amp input of PB Amp out

3 Explanation by Mode

A. Mute Control (pin 10)

Control Port	Mode	Function
Mute		Line SW
H	Mute Except for Mute	Open
L		Close

B. Explanation by mode

a) EE mode (Rear line IN)

The line input signal divided by RU29 and RU30 is input to pin 76 of IC, and output to pin 96 through ALC circuit and Line Amp.

At same time and the signal is passed through voltage divided circuit (RU08 and RU09) and CU06, input to REC Amp. ALC point is fixed on 4dBm by RU06 and RU07, and ALC time can be adjusted by RU31 and CU23.

b) PB mode

The signal from audio head input to pin 4 through frequency equalizer circuit composed of RR18 and CU15, This input signal is output to pin through EQ Amp.

It is input to pin 100 through buffer, R221 and finally output to pin 96 through Line Amp.

C) REC mode

The Audio input signal is passed Line Amp, and the level is reduced by divided circuit composed of RU08 and RU09. This signal is input to REC Amp through de-emphasis circuit composed of RU10 and CU07.

The audio signal from pin 7 of REC Amp is mixed with Bias signal, 70KHz and recorded in A/C Head.

DAEWOO

DAEWOO ELECTRONICS CO., LTD

686, AHYEON-DONG MAPO-GU
SEOUL, KOREA
C.P.O. BOX 8003 SEOUL, KOREA
TELEX : DWELEC K28177-8
CABLE : "DAEWOOELEC"
E-mail : djkoo@web.dwe.co.kr
TEL : 82-2-360-7806
FAX : 82-2-360-7877