

DAEWOO

Service Manual

Colour Television

CHASSIS : CP-365
PAL/SECAM SYSTEM
NTSC-3.58/4.43(AV) : TK ONLY

MODEL : DTT-21C1/21B1
2195/2172/2166
DTT-20C1/20B1
2075/2072/2066

UK : T204/T514

GOODMANS 20B1

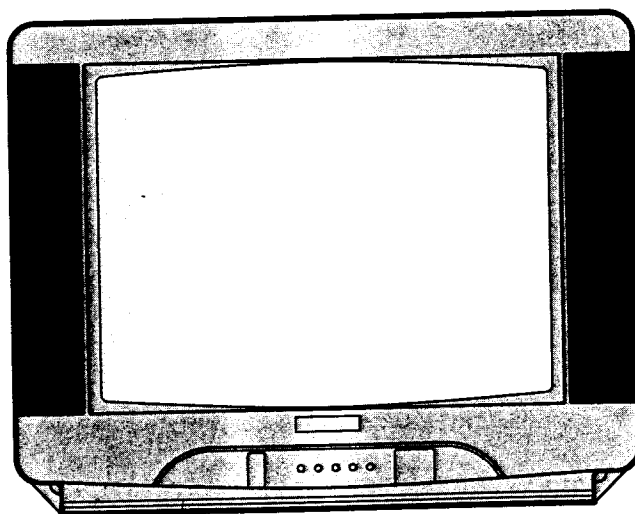

DAEWOO ELECTRONICS CO., LTD.

MC-Service

INCH	21"	20"
MODEL	DTT-21C1 xxF 21B1 xxF 2195 xxF 2172 xx-/xxF 2166 xx-	DTT -20C1 xxP/xxF -20B1 xxP/xxF -2075 xxP/xxF -2072 xx-/xxP/xxF -2066 xx-
REMARK	F : PHILIPS CRT - : ORION CRT	P : POLKOLOR CRT F : SAMSUNG WF CRT - : ORION CRT

CONTENTS

Specifications	2
Safety Instructions	3
Location of Controls.....	4
Operation of Controls	6
Assembly View	26
Installation and Service Adjustment.....	30
IC Operation Description	34
Circuit Description.....	63
IC/TR DC Voltage Charts.....	67
Printed Circuit Boards.....	70
Trouble Shooting Charts.....	74
Replacement Parts List.....	85
Exploded View	111
Schematic Diagram	118

■ SPECIFICATIONS

TV Standard	: PAL-B/G (FTZ) (Model: DTT-XXXXTF) PAL/SECAM-B/G, D/K (Model: DTT-XXXXTK) NTSC-3.58/4.43(AV) PAL/SECAM-B/G, D/K, SECAM-L/L' (Model: DTT-XXXXVA) PAL/B/G (Model: DTT-XXXXTS) PAL-I (Model: DTT-XXXXTU)
Mains Voltage	: 220-240V AC, 50Hz 110-260V AC, 50/60Hz (OPTION)
Power Consumption	: 90W approx (20 inch) 95W approx (21 inch)
Sound Output Power	: 2W + 2W (60% MOD)
Speaker	: 5W 8 ohms x2
Antenna Impedance	: 75 ohm unbalanced 300 ohm balanced with supplied balun
Tuning System	: Voltage Synthesizer Tuning System
Number of Program	: 100 Programmes
Reception Channel	: VHF: CH 2 to 12 UHF: CH 21 to 69 CATV: CH S1', S2', S3' and S1 to S20 HYPER: CH S21 to S41
Remote Control Unit	: Type R-22 or R-23 or R-28 (Requires two 1.5V penlight batteries type with AAA size)
Screen Size (Diagonal)	: 20": 48cm (Diagonal) 21": 51cm (Diagonal)
Teletext System	: 8 page memory FASTEXT (TOP/FLOF or LIST)
Aux. Terminal	: 21pin Euro-SCARTx2, Headphone(OPTION), S-VHS(OPTION), RCA JACK(OPTION)
Stereo System	: Two-carrier stereo, NICAM stereo (option)
Weight	: 20": 22.5Kg approx 21": 25.0Kg approx
Indication	: On SCREEN DISPLAY - Program No.(00-99) - SLEEP (15-120) - MUTE - AV - NORMAL (NORMAL I, NORMAL II, FAVOURITE) - MAIN MENU (CONTRAST, BRIGHT, COLOUR, SHARPNESS, TINT (NTSC OPTION)) - TIMER MENU (CLOCK, ON TIMER, OFF TIMER) - PRESET MENU (FAS, AUTO SEARCH, F/T, RENUMBER) - AUTO SEARCH MENU (SKIP, SEARCH, STATION NAME)

■ SAFETY INSTRUCTIONS

WARNING: BEFORE SERVICING THIS CHASSIS, READ THE "X-RAY RADIATION PRECAUTION", "SAFETY PRECAUTION" AND "PRODUCT SAFETY NOTICE" BELOW.

■ X-RAY RADIATION PRECAUTION

1. Excessive high voltage can produce potentially hazardous X-RAY RADIATION. To avoid such hazards, the high voltage must not exceed the specified limit. The nominal value of the high voltage of this receiver is 25.5kv (21": 26.5kv) at max beam current. The high voltage must not, under any circumstances, exceed 27.5kv (21": 29.5kv). Each time a receiver requires servicing, the high voltage should be checked following the HIGH VOLTAGE CHECK procedure on page 31 of this

manual. It is recommended the reading of the high voltage be recorded as a part of the service records. It is important to use an accurate and reliable high voltage metre.

2. The only source of X-RAY RADIATION in this TV receiver is the picture tube. For continuous X-RAY RADIATION protection, the replacement tube must be exactly the same type tube as specified in the parts list.

■ SAFETY PRECAUTION

1. Potentials of high voltage are present when this receiver is operating. Operation of the receiver outside the cabinet or with the back board removed involves a shock hazard from the receiver.

- 1) Servicing should not be attempted by anyone who is not thoroughly familiar with the precautions necessary when working on high-voltage equipment.
- 2) Always discharge the picture tube to avoid the shock hazard before removing the anode cap.
- 3) Discharge the high potential of the picture tube before handling the tube. The picture tube is highly evacuated and if broken, glass fragments will be violently expelled.

2. If any Fuse in this TV receiver is blown, replace it with the FUSE specified in the Replacement Parts List.

3. When replacing a high wattage resistor (oxide metal film resistor) in circuit board, keep the resistor 10mm away from circuit board.
4. Keep wires away from high voltage of high temperature components.
5. This receiver must operate under AC220-240 volts, 50Hz. (AC 110-260 volts, 50/60Hz: OPTION) NEVER connect to DC supply or any other power or frequency.

■ PRODUCT SAFETY NOTICE

Many electrical and mechanical parts in this chassis have special safety-related characteristics. These characteristics are often passed unnoticed by a visual inspection and the X-RAY RADIATION protection afforded by them cannot necessarily be obtained by using replacement components rated for higher voltage, wattage, etc. Replacement parts which have these special safety characteristics are identified in this manual

and its supplements, electrical components having such features are identified by designated symbol on the parts list. Before replacing any of these components, read the parts list in this manual carefully. The use of substitute replacement parts which do not have the same safety characteristics as specified in the parts list may create X-RAY RADIATION.

LOCATION OF CONTROLS

FRONT VIEW/CONTROL BUTTONS

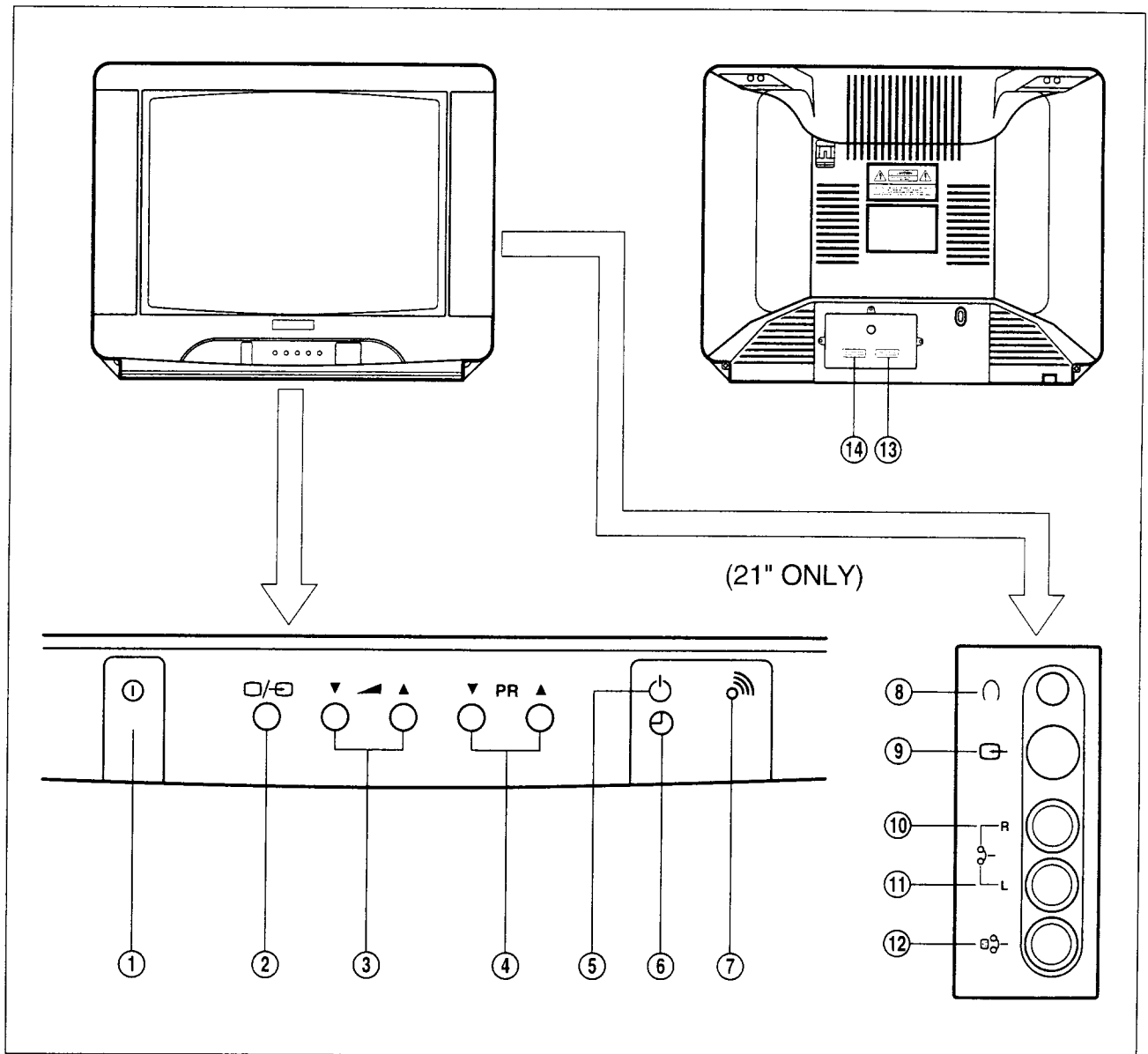

1) MAIN POWER SWITCH

2) TV/AV SELECTION BUTTON

3) VOLUME DOWN/UP BUTTON

4) PROGRAMME DOWN/UP BUTTON

5) STAND-BY INDICATOR

6) ON TIMER INDICATOR

7) INFRARED REMOTE SENSOR

8) HEADPHONE JACK

9) S-VHS JACK

10) RIGHT AUDIO INPUT RCA JACK

11) LEFT AUDIO INPUT RCA JACK

12) VIDEO INPUT RCA JACK

13) 21-PIN EURO-SCART 1 JACK (RGB, AV1)

14) 21-PIN EURO-SCART 2 JACK (S-VHS INPUT, AV2)

REMOTE CONTROL UNIT

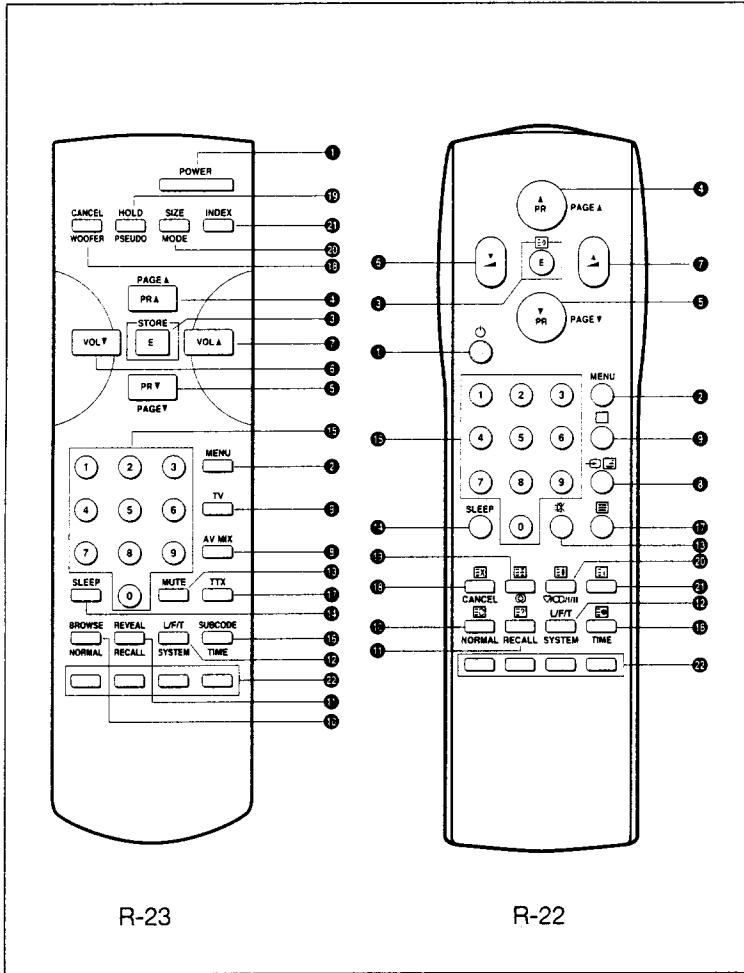

	◆ TV USE	◆ TEXT USE (OPTION)
1	POWER p6	—
2	MENU p7	—
3	ENTER p8	STORE P19
4	UP (PR UP) p6	PAGE UP P17
5	DOWN (PR DOWN) p6	PAGE DOWN P17
6	LEFT (VOL DOWN) p6	—
7	RIGHT (VOL UP) p6	—
8	AV p15	MIX P18
9	TV p15	—
10	NORMAL p14	BROWSE P18
11	RECALL p14	REVEAL P18
12	—	L/F/T P19
13	MUTE p16	—
14	SLEEP p13	—
15	PR SELECTOR 0-9 p6	PAGE SELECT 0-9 P17
16	TIME p15	SUBCODE P19
17	—	TTX P17
18	—	CANCEL P18
19	PSEUDO p16	HOLD P18
20	MODE p16	SIZE P18
21	—	INDEX P18
22	—	RGYC P19

■ OPERATION OF CONTROLS

POWER ON/OFF

- Before plugging in your set, confirm that your power supply is suitable.
Your new TV is designed to operate on AC 220-240V 50Hz.
Do not operate on DC power supplies or any other voltage.
- Plug in to the mains outlet.
- Switch the TV on by pressing the Main Power Switch ①.
The Stand-By Indicator ⑤ will illuminate.
The TV will then be in Stand-By mode.
- Next press either: -
PROGRAMME UP or DOWN button ④ on the front of the TV,
The POWER button ① or one of the PR SELECTOR ⑮ buttons 1-9 on the Remote Control.
The Stand-By indicator will turn off and a picture appear on the screen. A programme number and space for station name (not yet recorded so indicated as ----) will appear on the upper left of the screen in green and disappear after five seconds.
- Press the POWER button ① on the Remote Control to return the TV to Stand-By mode.

PR SELECTOR 0~9 ⑮

In normal TV mode, these buttons are used for direct programme selection and can also be used for turning on the TV.

DOWN AND UP (PR ▲/▼) ④ ⑤

In normal TV Mode, these buttons are sequential programme selection buttons, but a programme designated by you as SKIP ON cannot be selected. For details about the SKIP ON/OFF function see page 10.

LEFT & RIGHT (▲/▼) ⑥ ⑦

Pressing the RIGHT ▲ button increases the sound volume and pressing the LEFT ▼ button decreases it.

When these buttons are pressed a volume indication bar appears at the bottom of the TV screen in green colour.

REMOTE CONTROL

The Remote Control Unit operates with two 1.5V AAA(penlight) batteries which are supplied from the factory.

To renew the batteries turn the unit upside down, press down on the battery compartment grip and slide the cover in the direction of the arrow.

When installing the batteries make sure that the polarity matches with the (+) and (-) marks inside of the battery compartment.

The Remote Control is designed to operate within a distance of about 7 metres. If a malfunction occurs within this effective operating range the batteries may be weak and require replacement. Do not mix old and new batteries.

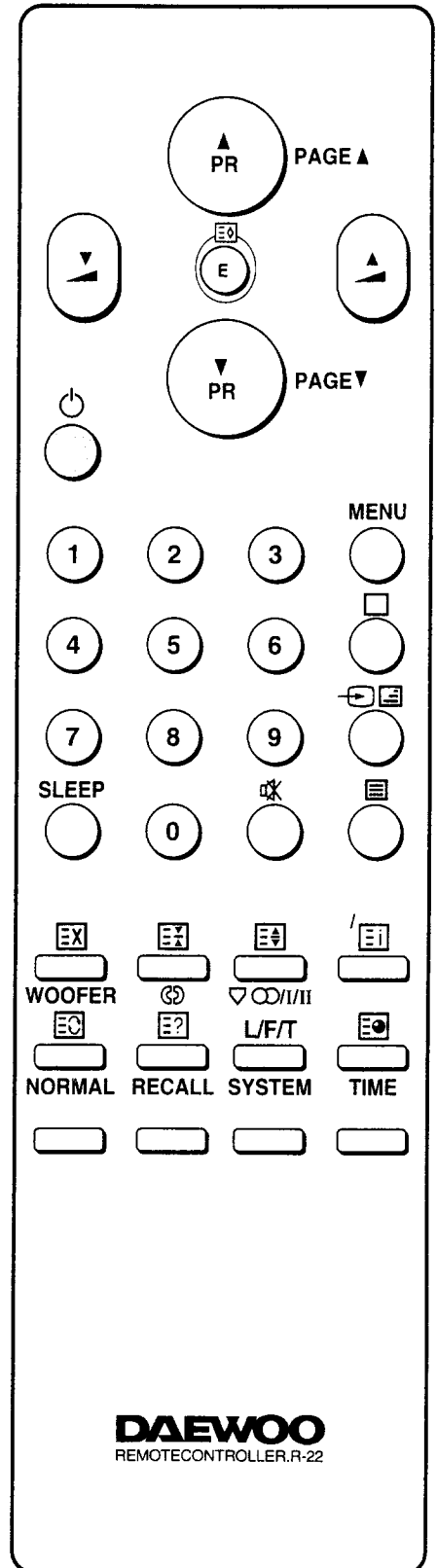

MENU ②

Your TV set has an up-to-date feature that you need to learn how to use an early stage.

It's called MENU ② and it is a way of programming your TV to operate efficiently without the constant need for adjustment of controls.

Those functions that are not used very frequently are only accessible via MENU and MENU itself is operated by just six buttons:

MENU	②	ENTER	③
DOWN	⑤	UP	④
LEFT	⑥	RIGHT	⑦

plus the PR SELECTOR buttons 0-9. ⑩

The main MENU is activated by pressing the MENU button and appears on the screen as shown.

The cursor(the arrow head on the left of the On Screen Display) is moved by pressing the DOWN or UP buttons.

A Sub-Menu is entered by placing the cursor against the topic required and pressing ENTER.

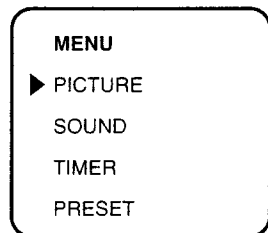

1. PICTURE

The Sub-Menu for PICTURE is shown on the right. This allows you to set the BRIGHTNESS(☀), COLOUR(🌈), CONTRAST(🌑) and SHARPNESS(📏) for your TV picture.

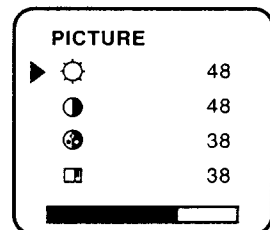

2. SOUND

The Sub-Menu for SOUND allow you to set the BASS, TREBLE, and BALANCE for your TV sound.

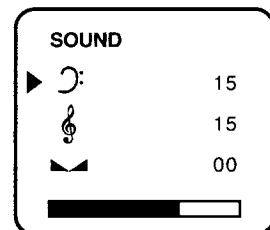

3. TIMER

The Sub-Menu for TIMER allows you to set the TV clock, and pre-programme the TV to turn on and off when required.

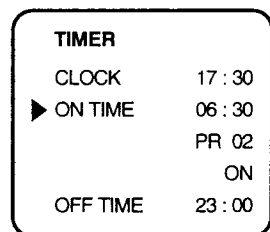

4. PRESET

Finally, the Sub-Menu for PRESET allows you to preset all your TV stations as required, to fine tune the programme and to select the channels.

If you wish to come out of any of the Sub-Menus you simply press the MENU button and you will return to the higher level in the menu tree.

If you press MENU again while you are in the main Menu, Menu mode will be cancelled. Pressing the TV button can also be used to quit the MENU mode at any level.

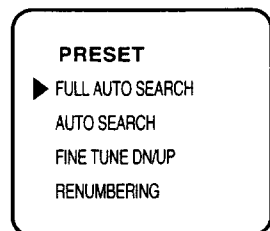

Note that when Teletext is being operated the only MENU selectable is PICTURE and this menu is activated when the MENU button is pressed in the Teletext mode. The MENU mode is cancelled by pressing the MENU button again.

PICTURE

Select the required function by moving the cursor with the DOWN **5** or **4** UP button.

Use the LEFT **6** or RIGHT **7** button to adjust the level of each function-the level being indicated at the bottom of the On Screen Display.

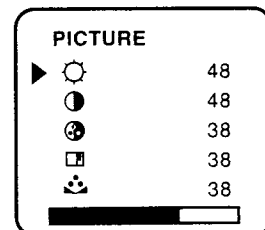

1. BRIGHTNESS (☀)

Adjust for natural brightness if your TV picture appears to be too bright or too dark.

2. COLOUR (🎨)

Adjust your TV picture for the strength of colour preferred.

3. CONTRAST (◐)

Use this to obtain a satisfactory range of tones between black and white. Remember that a bright room will need a higher contrast setting than a dark room.

4. SHARPNESS (📏)

This sharpens the image of the picture. It is the most usable when watching programmes from an external source such as a VCR.

5. TINT (🎭) -[OPTION : NTSC]

TINT adjustment changes the tone of colour.

This OSD sign only appears when the 3.58NTSC signal is input in AV MODE.

Note that COLOUR and SHARPNESS adjustment is not possible for Teletext or when using the RGB input of the SCART socket.

SOUND

Select the required function by moving the cursor with the DOWN **5** or UP **4** button.

Use the LEFT **6** or RIGHT **7** button to adjust the level of each function-the level being indicated at the bottom of the On Screen Display.

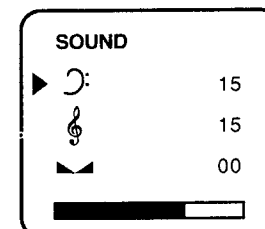

1. BASS (🎵)

Used to increase or decrease the bass of sound.

2. TREBLE (🎵)

Used to increase or decrease the treble of sound

3. BALANCE (⚖)

Adjust the balance for the best stereo effect for your room conditions.

TIMER

1. CLOCK

Place the cursor at CLOCK using the UP **4** or DOWN **5** button and press ENTER **1**.

The hour will start blinking.

Set the hour by using the LEFT **6** or RIGHT **7** button.

The minutes will start blinking

Move the cursor to MINUTES by pressing the DOWN **5** button and set the minutes by using the LEFT **6** or RIGHT **7** button.

Then you can either press the DOWN **5** button again, in which case the cursor will stay at CLOCK, or press the UP **4** button, in which case the time will start blinking again. Then you can then make a final adjustment to the time, if you wish, press the UP **4** button again to move to the initial CLOCK mode.

TIMER	
▶ CLOCK	17:30
ON TIME	06:30
	PR 02
	ON
OFF TIME	23:00

2. ON TIME

Place the cursor at ON TIME and set on time in a similar way as in CLOCK.

TIMER	
CLOCK	17:30
▶ ON TIME	06:30
	PR 02
	ON
OFF TIME	23:00

3. ON TIME PR. No.

Place the cursor at PR. No. and select the programme number by using the PR SELECTOR **15** buttons 0-9 or the LEFT **6** or RIGHT **7** button.

When a valid programme number is input the TV will automatically switch on to this programme.

TIMER	
CLOCK	17:30
ON TIME	06:30
▶	PR 02
	ON
OFF TIME	23:00

4. ON TIME ON/OFF

Place the cursor at ON TIME ON/OFF and toggle from ON to OFF by using the LEFT **6** or RIGHT **7** button. This facility is only available when CLOCK and TIME have been activated.

When ON TIME is ON, then the ON TIME INDICATOR **6** on the front of the TV will illuminate to show that the ON TIME function is enabled.

TIMER	
CLOCK	17:30
ON TIME	06:30
	PR 02
▶	ON
OFF TIME	23:00

5. OFF TIME

Place the cursor at OFF TIME and press ENTER **1** button to set OFF TIME as in the CLOCK mode above.

TIMER	
CLOCK	17:30
ON TIME	06:30
	PR 02
	ON
▶ OFF TIME	23:00

Note that if the OFF TIME value is --:-- then the OFF TIME is disabled. Any other entry will cause OFF TIME to operate.

PRESET

The Preset Menu is used to operate the tuning function and tune your TV channels. It cannot be selected whilst in either Teletext or AV mode.

1. FULL AUTO SEARCH

In the Preset Menu place the cursor on FULL AUTO SEARCH by using the UP or DOWN button. Press ENTER and the TV will automatically tune itself to all available channels from 0-99, from

VHF-1(SECAM-L) → VHF-3(SECAM-L) → UHF(SCAM-L) → VHF-1
 UHF-3 ← VHF-3 ←

In case of SECAM-L mode, the letter "F" is displayed beside band name.

Where it detects a signal it will store the location under a programme number: starting with "1" and automatically increasing the number as it searches for the next station.

When all 100 programmes have been stored-or the searching of all available stations has been completed-the TV will return to the Preset Menu again.

If you wish to cancel Full Auto Search use MENU 2, TV 3 or Power 1 button.

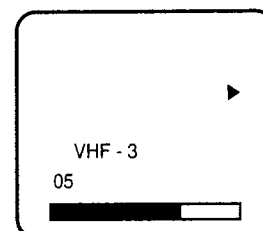
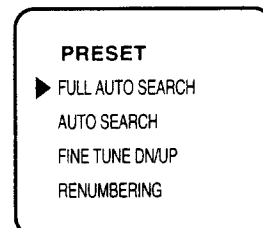

2. AUTO SEARCH

In the Preset Menu place the cursor on AUTO SEARCH by using the UP 4 or DOWN 5 button. Press ENTER 3 and the Auto Search Menu is displayed as shown. If you wish to return to the Preset Menu press MENU.

If you'd like to get SECAM-L broadcasting, select SECAM-L mode by pressing SYSTEM button. You can see the letter "F" beside PR No.

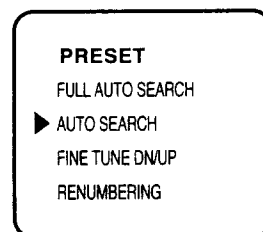

2.1. The Programme Number is changed by using the LEFT 6 or RIGHT 7 button or the PR SELECTOR 15 buttons 0-9. Select a programme number that you will recognize: eg. 01 for BBC1:02 for BBC2:03 for ITV1:04 Channel 4 etc.

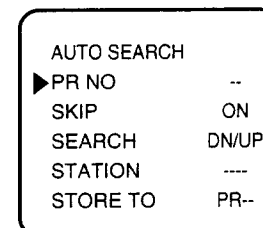

2.2. Skip On/Off is changed from ON to OFF by toggling the LEFT 6 or RIGHT 7 button and whenever it is toggled it is memorized immediately. A programme marked with SKIP is skipped when using the Programme DOWN 5 or UP 4 button. Use the SKIP facility to skip the poorer reception channels that your TV may tune automatically.

A skipped PR No. selected by Programme DOWN 5 or UP 4 will be displayed in red on the screen.

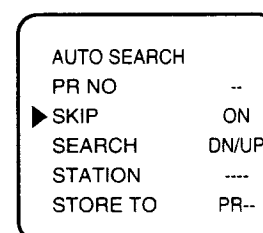

2.3. Search Down/Up is operated by using the LEFT **6** button for Search Down and the RIGHT **7** button for Search Up.

When a station is found it changes to Auto Search menu. When the tuning reaches the top of a band, it will be changed to the next band. The band is switched as follows:

VHF 1 ↔ VHF 3 ↔ UHF ↔ VHF 1

If you press this button and keep it pressing for 2 seconds, the band will be changed

If you set mode SECAM-L, the letter "F" is displayed beside band name.

AUTO SEARCH	
PR NO	--
SKIP	ON
▶SEARCH	DN/UP
STATION	----
STORE TO	PR--

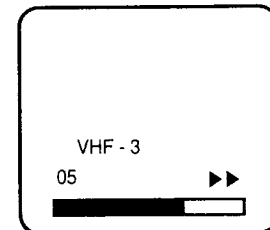

2.4. Station is used to record the station name: place the cursor on STATION and press ENTER **8**

The first character from the left of the four available characters will start blinking.

AUTO SEARCH	
PR NO	--
SKIP	ON
SEARCH	DN/UP
▶STATION	----
STORE TO	PR--

If you press the DOWN **5** button, the blinking is moved one space to the right: the UP **4** button moves the blinking one space to the left. Press the LEFT **6** or RIGHT **7** button and the actual character displayed is changed by one digit or letter sequentially in each direction. In this way you can make sure that PR No.01 is called BBC1: and PR No. 02 is called BBC2 etc.

If you make a mistake in the station name you can revert to the initial blank mode (----) by pressing RECALL. **11**

AUTO SEARCH	
PR NO	--
SKIP	ON
SEARCH	DN/UP
▶STATION	----
STORE TO	PR--

2.5. Store to PR No. is used to memorize all the above functions which have been operated in Auto Search mode. Place the cursor at STORE TO PR.NO. and select the PR. No. by pressing LEFT **6** or RIGHT **7** button or one of the PR SELECTOR **15** buttons 0-9.

Press the ENTER **8** button after selecting the PR. No. required and it will be memorized. Note that while this is being carried out the colour of the line changes to RED and then returns to Green after 1 second.

AUTO SEARCH	
PR NO	--
SKIP	ON
SEARCH	DN/UP
STATION	----
▶STORE TO	PR--

3. FINE TUNE DOWN/UP

If you are unable to get a good picture or sound because of a poor broadcasting signal it is possible to adjust the fine tuning to try and improve reception.

In the Preset Menu move the cursor to FINE TUNE DN/UP and press the LEFT **6** or RIGHT, **7** buttons to activate FINE TUNE DN/UP.

Note that it only operates whilst the LEFT or RIGHT button is being pressed and that after fine tuning has been completed, the PR No. changes from green to yellow.

Please note that if you quit the MENU by pressing the TV **9** button after a Fine Tune adjustment, the new tuning is memorized.

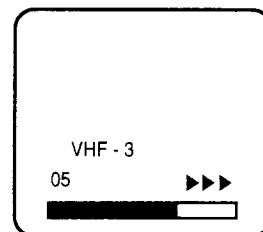
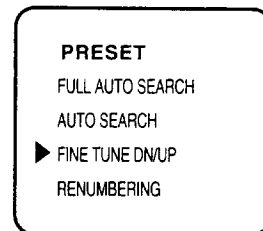

4. RENUMBERING (option : PAL-I MODEL)

Renumbering is used to re-arrange the PR.No and station names.
 In the Preset Menu move the cursor to RENUMBERING and press ENTER **3**.

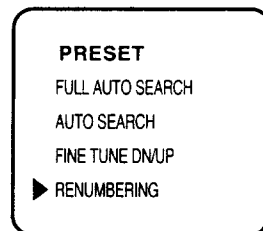

The Renumbering sub-menu is displayed as shown. The centre line is shown in red and the other lines in green.

Place the cursor at the bottom of your selected side by using the UP **4** or DOWN **5** button. When a LEFT **6** or RIGHT **7** button is pressed the programme number can be moved by the DOWN **5** or UP **4** button. Note that the channel display on the screen is shown in the centre line of the left side. Exchange is executed by pressing the ENTER **3** button, whereupon the content of TV programme and station name will be exchanged.

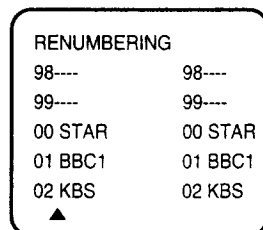

SYSTEM

This button is valid in AUTO SEARCH menu and normal TV mode.
 The SECAM-L mode is selected by this button and selected mode is stored to each PR. The SECAM-L mode is displayed as "FRANCE" in normal TV mode and "F" in AUTO SEARCH menu.

SLEEP 14

By pressing the SLEEP 14 button you can set your TV to turn automatically off up to two hours ahead.

When you press the SLEEP 14 button the OFF sign of the non-set sleep-timer appears in the upper left side of the screen.

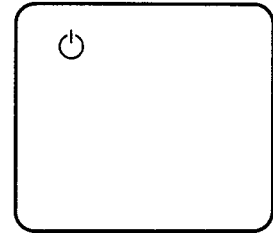

Press the SLEEP 14 button again and 15 minutes is set to the timer. The on screen display stays for five seconds unless any button is pressed.

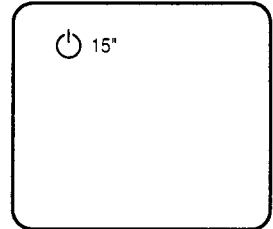

If the SLEEP 14 button is pressed again within 5 seconds then the setting time is increased by 15 minutes, up to a maximum timer setting of two hours (120 minutes).

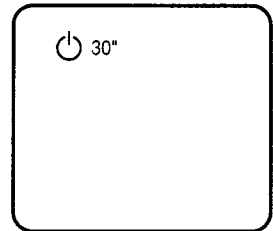

During the operation of the Sleep-Timer, if the SLEEP 14 button is pressed again the remaining time on the Sleep-Timer is displayed on the screen.

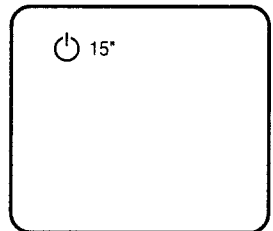

If the SLEEP 14 button is pressed again then 15 minutes replaces whatever time is left and a further 15 minutes is added each time the button is pressed, as before.

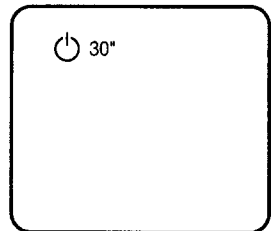

When the remaining time on the Sleep Timer becomes zero, the TV is turned off.

Note: If a broadcast signal is not continuously present for approximately 15 minutes, the TV will automatically be turned off if it is in TV mode. In AV mode, however, this function does not operate.

NORMAL 10

Select one of the three possible preferred settings for your TV picture.

Favourite



Normal I

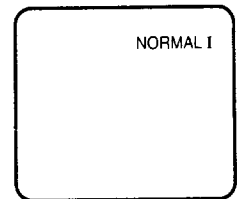

Normal II

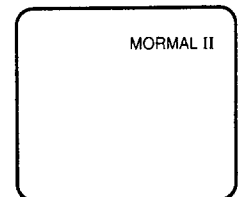

The three levels of setting are as follows:

Preference	Brightness	Contrast	Colour	Sharpness
Favourite	User Store	User Store	User Store	User Store
Normal I	38/64	58/64	48/64	58/64
Normal II	48/64	38/64	48/64	38/64

RECALL 11

The RECALL 11 button is used to display the current state or mode of the TV.

1. Station Name, PR No., Current Sound mode.
2. Current Time and On Time.
3. Current Time and Off Time.

This display appears for 4 seconds unless any button is pressed and whenever it is pressed again it changes as follows:

Press again within 4 secs and display changes to current time and ON time.

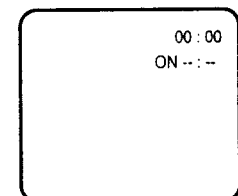
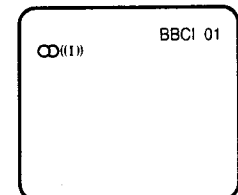

Press again, and display changes again to current time and OFF time.

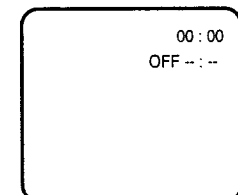

Press again, and the screen is cleared. If you keep this button pressing the sequence repeats itself.

TV AND AV ③

Use the AV ③ button on the Remote Control or TV/AV ② button on the front of the TV to select one of the four options or two external inputs you may wish to view.

Whenever the TV/AV ② button is pressed the on-screen display will be changed as shown:

Press once

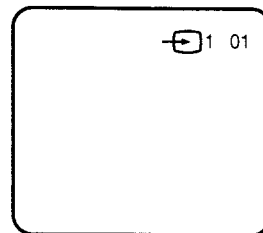

Press again

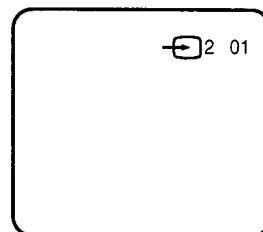

Press again

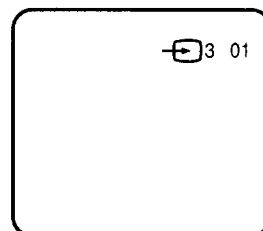

Press again

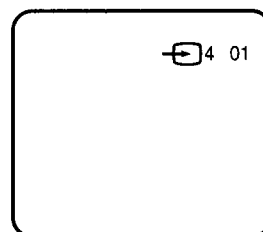

Press again

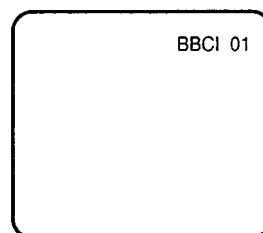

But, when you press the AV ③ button on the Remote Control the screen display will follow exactly the same pattern except for the last change when it will return to AV1 not TV. To return to TV press button. TV ① button.

The descriptions of each input are as shown below:

AV1: Full Euro Scart

AV2: S-VHS Euro Scart

AV3: RCA Input (option)

AV4: S-VHS Input (option)

TIME ⑩

When the TIME ⑩ button is pressed in TV mode, the Time is displayed for 5 seconds on the upper right side of the screen. The Time is extracted from the Teletext signal, however, and if the programme you are watching has no Teletext transmission present no time will be displayed.



MUTE 13

Pressing the MUTE 13 button cuts off all sound from the speaker and displays  on the screen in red.

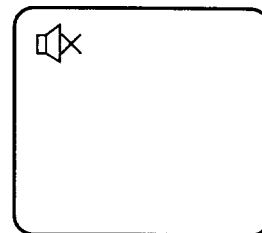

To return to full sound, press the MUTE 13 button again: sound will return and  will be displayed on the screen in red.

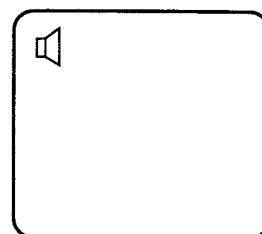

PSEUDO 19

The PSEUDO 19 button is used to obtain a pseudo stereo effect with mono transmissions. When the button is pressed once an EFFECT indication as shown appears on the upper left side of the screen in red and the station identification is on the top right side.

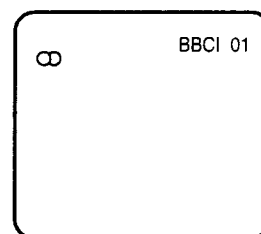

Press the button again and a further EFFECT indication appears as shown.

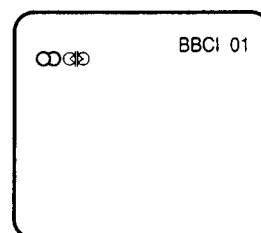

MODE 20

The MODE 20 button is used to change the sound mode. During a stereo transmission, pressing the button will change the sound from stereo to mono.

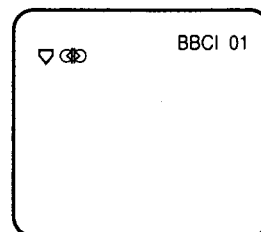

Pressing it again will change it back to stereo. During a bilingual programme transmission, pressing the MODE button will change the language to the second channel: pressing again will change it back to the main channel.

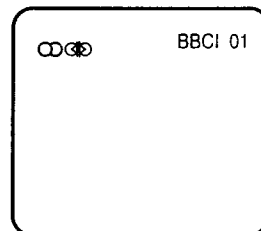

■ TELETEXT

The Teletext service is carried on a TV transmission signal, therefore it is only available when a TV programme can be received on your TV. Your choice of TV programme also governs which Teletext service you will receive (CEEFAQ for BBC1 and 2, Oracle for ITV and Channel 4).

GETTING STARTED

First, turn on your TV and choose your TV programme.
Then press the TEXT button **17** to switch the receiver to TV mode.

Note that when Teletext is first selected, index page 100 is automatically obtained when the TV is in TOP mode. If the TV is in LIST mode, then the Teletext page which is stored in the red rank is obtained.

To select any other page simply press the three of the PAGE SELECTOR **15** buttons or PAGE DOWN **5** or UP **4** button. The Page number requested is displayed on the upper left side of the screen and when the third digit (each main page number consists of three digits) is entered the page header display changes colour from white to green to indicate that the page currently being displayed is not yet the requested page. On receiving the new page the header changes to white, and the rolling number in the centre is stationary.
To return to normal TV operation the TV **9** button is pressed.

Note that if the new page requested is a newsflash or subtitle page, the normal TV picture is automatically turned on and the newsflash or subtitle displayed in a box within the picture.

PAGE SELECTOR 0-9 **15**

In Teletext mode, the PAGE SELECTOR **15** buttons are used to enter a page number or subcode. As digits are entered they are displayed as shown.

1st Digit:-	1	See SUBCODE for details on how to enter sub-code page numbers.
2nd Digit:-	2	
3rd Digit:-	3	
4th Digit:-	4	

During digit entry page acquisition is stopped.

PAGE DOWN/PAGE UP **4** & **5**

Page Number DOWN **5** and UP **4** buttons decrease or increase the current page number by 1.

INDEX () 21

When the Index 21 button is pressed in TOP mode, the Teletext decoder is set up to display the index page. Press once for Main Index Page: press again for full index. When the TV is in LIST mode this button has no function.

MIX () 8

In normal Teletext mode TV picture and character data are not displayed simultaneously. The MIX 8 button allows a combined display of TV picture and character data.

SIZE () 20

By pressing the SIZE 20 button either the top or the bottom half of the Text display can be expanded. Press the SIZE button 20 once and the top half of the display is expanded. Press again and the bottom half is expanded. Press again and the display returns to normal size characters.

BROWSE () 10

The BROWSE 10 button allows the user to scan very easily through the entire database. In its simplest sense, BROWSE instructs the decoder to capture the next complete Teletext page which arrives, therefore it can be seen as an almost instant way of accessing random pages in the Teletext database and thereby removing the need of pressing buttons to glance a unfamiliar pages.

REVEAL or RECALL () 11

Some Teletext pages play a role to conceal the display, for example a quiz page with concealed answers. The REVEAL button re11ses the concealed text as long as it is not pressed again.

HOLD () 19

Some Teletext pages contain more information than can be displayed simultaneously therefore they are sub-divided into a series of two or more pages.

The first sub-page series of four sub-pages will, for example, be indicated by a 1/4 display on the top right side of the text page. These sub-pages are automatically rotated, each page being displayed for a set time before being replaced by the next page. If you need to read a certain page for longer than is allowed, or retain a particular sub-page, then the HOLD 19 button should be pressed.

The HOLD symbol will be displayed on the top left side instead of the page number and page acquisition will be stopped.

Normal operation is restored by pressing the HOLD 19 button again or by entering a new page number.

CANCEL () 18

The CANCEL 18 button suppresses the Text display and restores the normal TV picture while the receiver remains in Teletext mode. This function allows you to request Teletext pages and alter Teletext controls without interrupting a TV programme.

SUBCODE () 16

For Teletext information which is longer than one page, it may take some time for the automatic changing of sub-pages to reach the sub-page you require. It is possible, however, to enter the sub-page you require and continue watching a normal TV programme until the correct sub-page has been reached.

Press SUBCODE **16** button.

The characters Pxxx/--- will be displayed on the bottom left side of the Text screen.

Enter the desired sub-page number. EG. To select sub-page 10, press 0,0,1,0 buttons.

Press CANCEL **18** button to return to normal TV programme.

When the correct sub-page is reached, the main page number will be superimposed on the normal TV picture.

Press the Teletext **17** button to display the stored sub-page.

R, G, Y, C **22**

When the TV is in LIST mode the page numbers available for the four coloured buttons (R.,G.,Y.,C.) are displayed in the Text status row. Your selection is made by pressing the coloured button **22** that correspond with the desired coloured number.

L / F / T **12**

Press the L/F/T **12** button to select the Teletext LIST mode. The letter "L" and four coloured page numbers will appear at the bottom of the screen. To see one of these pages, press the matching coloured button **22** (R.,G.,Y.,C.).

To change the favourite page numbers press a coloured button **22** and then three page selector **15** buttons on the remote control in sequence.

e.g. To select page 100 on the RED background, press the R **22** button, then three digits **15** (1,0,0) in sequence. Page 100 will be shown on the red background.

This can be repeated with other page numbers and colours as required.

STORE () **3**

The STORE **3** button is used to store a list of numbers. While the list is being stored the coloured numbers turn to white for 3 seconds.

■ CONNECTING THE EXTERNAL EQUIPMENT

Your TV is equipped with a 21-pin EURO-SCART for the connection of desired equipment.

To connect a VCR please refer for full details to the Instruction Manual for your VCR. The diagram below shows the basic connections.

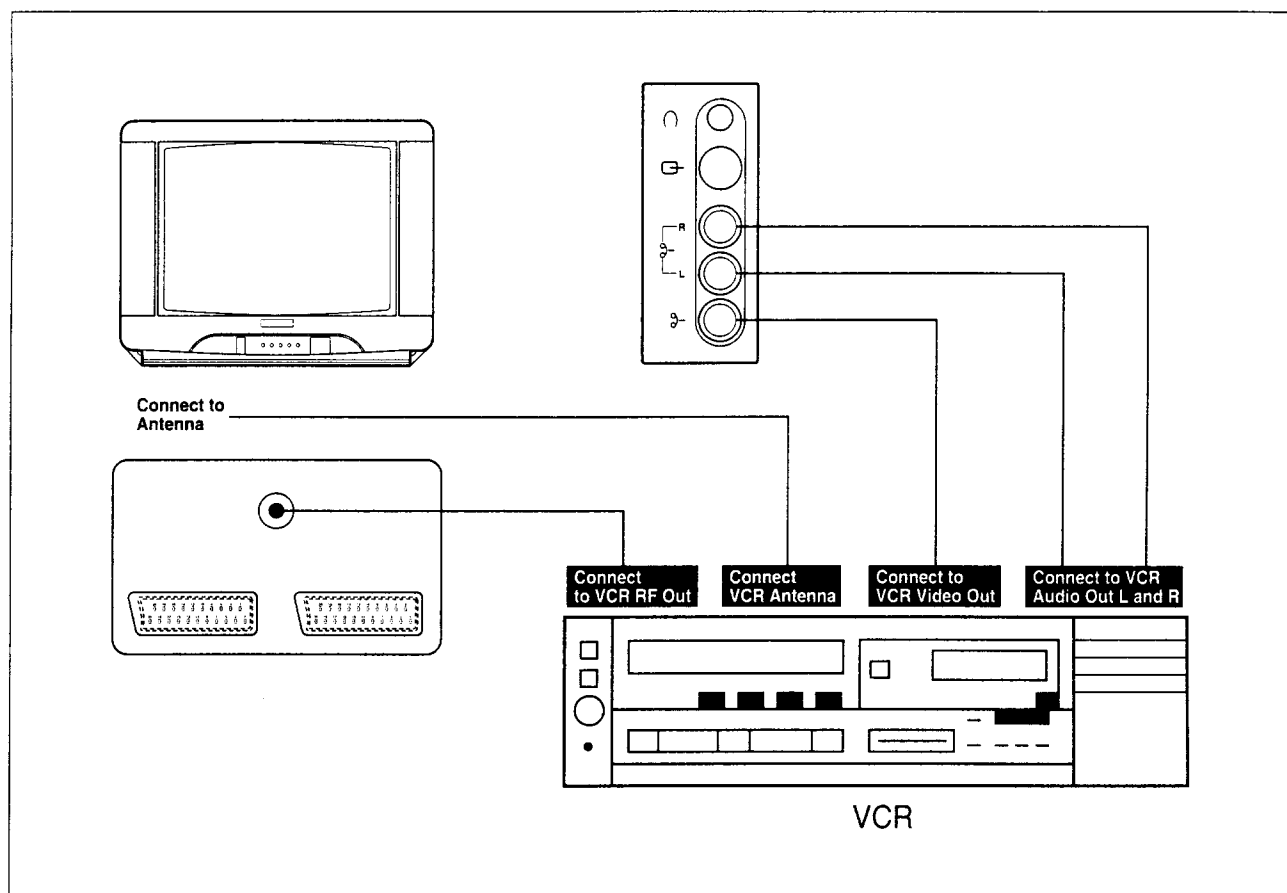

USE OF THE 21-PIN SCART TERMINAL

A personal computer, VCR, Video disc or other AV apparatus can be connected to the 21-pin socket (EURO-SCART) on the rear panel of your TV.

• Use of Video equipment

- With equipment which has an 8-pin input function signal in the 21-pin socket you can play programmes from VCR tapes or video discs etc.

When you connect the SCART-1 apparatus to the TV through the 21-pin terminal, the programme display will be automatically changed to AV1 mode. If the equipment does not change the function signal, change the AV1 mode yourself to enable playback as required.

• Use of Personal Computer

- The personal computer must be the type which has a 16-pin fast signal (TV/RGB switching) through a 21-pin socket. If the personal computer is not this type but has an RF output terminal, you can connect it to the antenna terminal on the TV.

NOTE :

In TV mode, if a broadcasting signal is not continuously present for approximately 15 minutes, the receiver will be automatically turned off. In AV mode, however, this does not happen.

■ SCART SOCKET 1 CONNECTIONS(AV1)

PIN	DESCRIPTION	PIN	DESCRIPTION
1	Audio Output (R)	12	Not Connected
2	Audio Input (R)	13	Earth (Red)
3	Audio Output (L)	14	Earth (Blanking)
4	Earth (Audio)	15	Red (R) Input
5	Earth (Blue)	16	RGB Switching (Blanking)
6	Audio Input (L)	17	Earth (Video Out)
7	Blue (B) Input	18	Earth (Video In)
8	Function Switching (TV/AV)	19	Video (Sync.) Output
9	Earth (Green)	20	Video (Sync.) Input
10	Not Connected.	21	Earth (Case)
11	Green (G) Input		

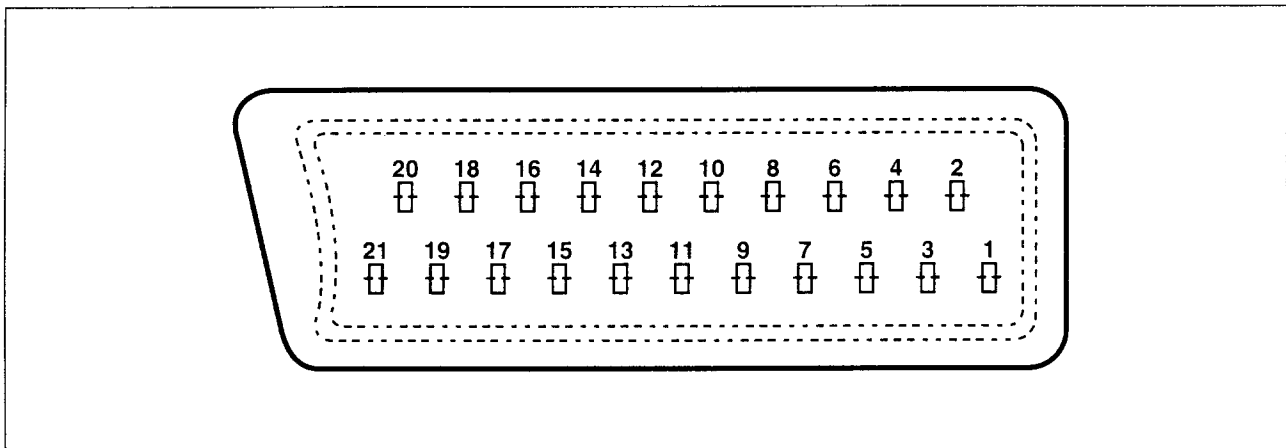

■ SCART SOCKET 2 CONNECTIONS(S-VHS INPUT, AV2)

PIN	DESCRIPTION	PIN	DESCRIPTION
1	Not Connected	12	Not Connected
2	Audio Input (R)	13	Earth
3	Not Connected	14	Earth
4	Earth (Audio)	15	C Input
5	Earth	16	Not Connected
6	Audio Input (L)	17	Earth
7	Not Connected	18	Earth
8	Not Connected	19	Earth
9	Earth	20	Y or Video Input
10	Not Connected	21	Earth (Case)
11	Not Connected		

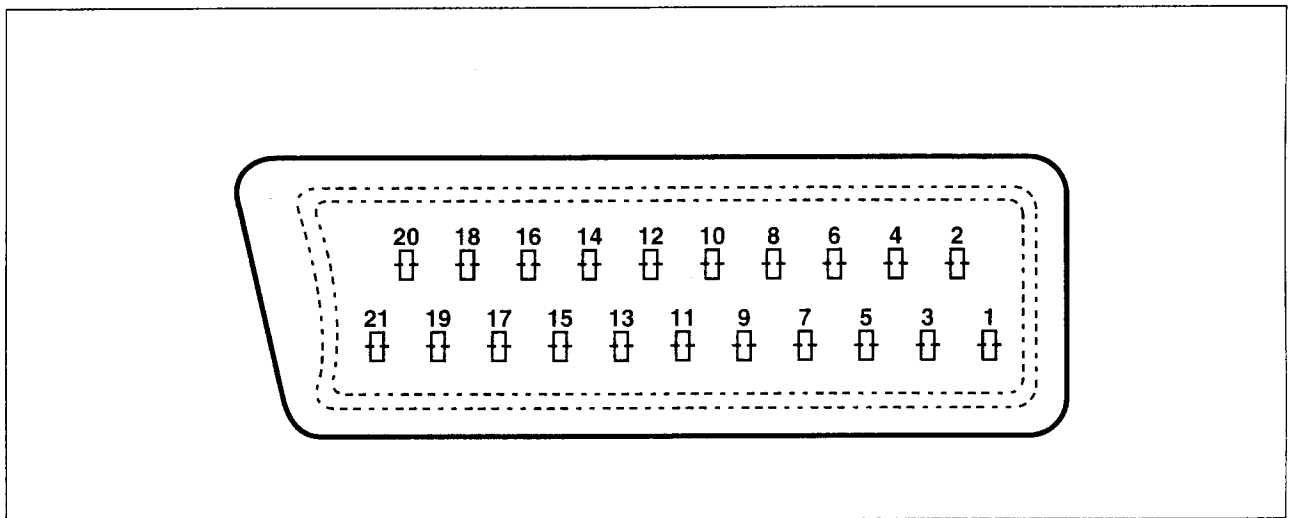

USE OF RCA JACK(AV INPUT) TERMINALS

- The Audio/Video input terminals can be used for connection of devices such as video cassette recorders, video disc players, satellite receivers, video cameras, personal computers etc. Which have Audio/Video output terminals.
- Connect the video input terminal to the video output terminal of the external device. The terminal is a phono pin type.
- Connect the Audio-R/L input terminal to the Audio-R/L output terminal of the external device. The terminal is a phono pin type.

NOTE :

As connection terminology and individual operating features of the equipment may vary, to ensure proper operation be sure of reading carefully the operating manuals for the VCR and other equipment you are using.

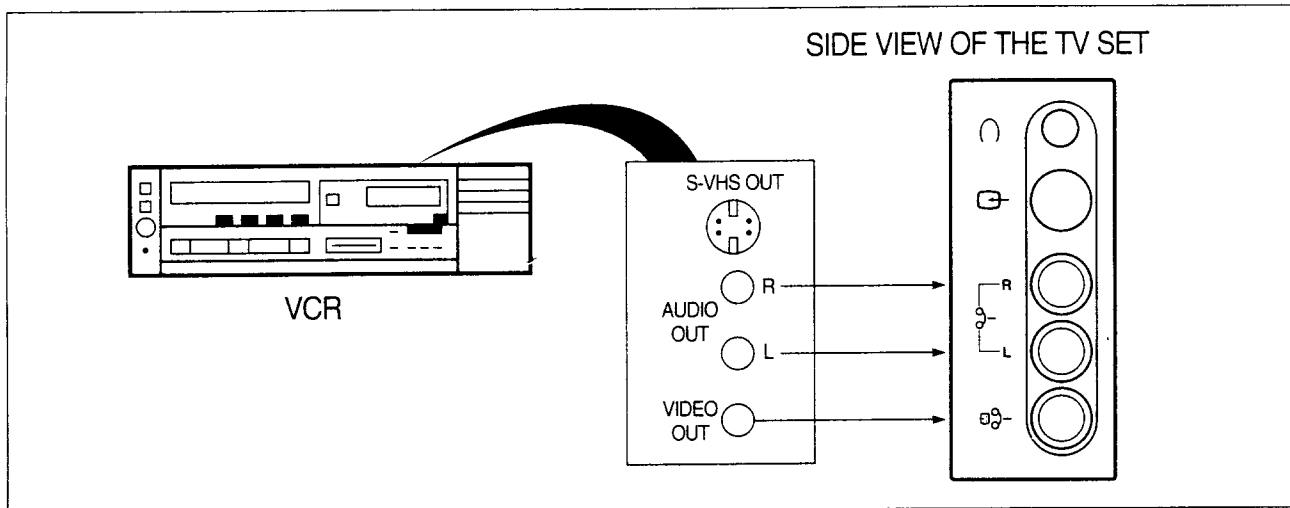

- To set the TV to AV3 mode press the button on the Remote Control. The AV3 is displayed on the upper part of the screen to be used as a monitor for Audio/Video signals from a VCR, Video disc player, personal computer etc.

USE OF SUPER-VHS TERMINAL

- The Super-VHS input terminal can be used for the connection of devices such as video cassette recorders, video disc players, etc which have the S-VHS output and Audio-R/L output terminal. Connect as shown in the illustration.
- To set the TV to AV4 mode, press the button on the Remote Control until AV4 is displayed on the screen.
- Your TV is also equipped with a 6mm stereo headphone jack.
- The volume is controlled on the headphone in the normal way and when the headphone jack is inserted the internal loudspeakers are muted.

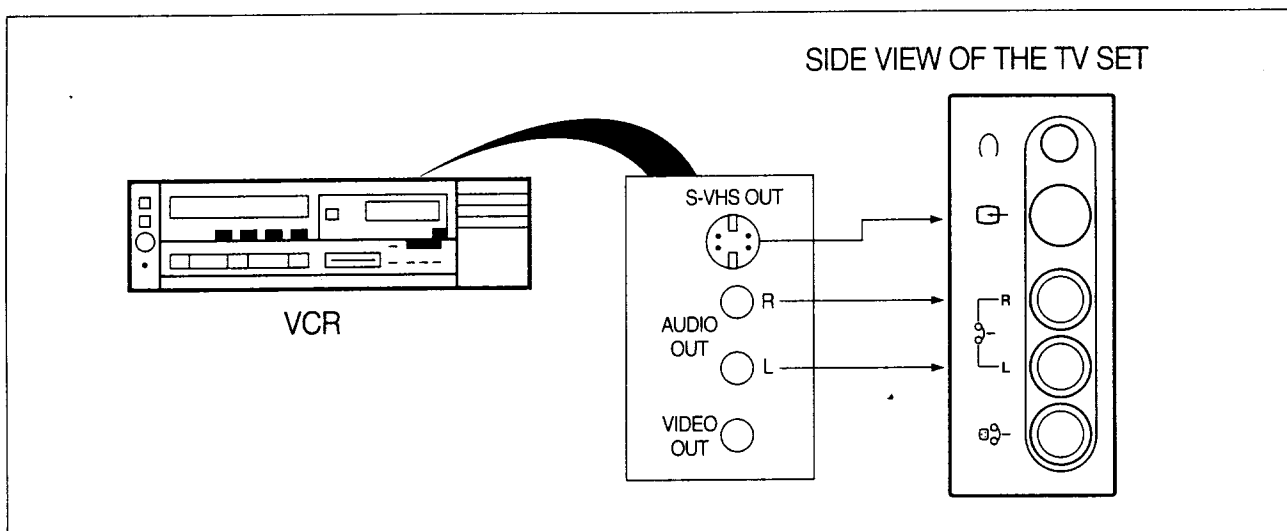

■ TROUBLESHOOTING

Sometimes a performance problem can be easily solved by checking seemingly apparent but often overlooked possibilities.

Checking these points before asking for service could save your time and money.

SYMPTOM	CHECK POINT
No picture and sound.	<ul style="list-style-type: none"> • Check the TV set is plugged in. • Check the Volume, Brightness and Contrast controls are set to the minimum positions.
Picture is OK, but no sound.	<ul style="list-style-type: none"> • Check the Volume control is set to the minimum position.
Sound is OK, but no picture	<ul style="list-style-type: none"> • Check the Brightness and Contrast controls are set to the minimum position.
No colour	<ul style="list-style-type: none"> • Check the Colour control is set to the minimum position.
Excessive noise in picture.	<ul style="list-style-type: none"> • Check the Antenna cable is broken or disconnected or damaged.
Diagonal stripes appear on picture.	<ul style="list-style-type: none"> • The picture may be affected by an interfering signal. (eg. from near by amateur radio transmitters or another TV set). • The interference can be reduced to some extent by adjusting the direction or height of the antenna or, if a twin lead antenna cable is being used, replacing it with a coaxial cable.
Picture has "snow"	<ul style="list-style-type: none"> • Check the Antenna cable is broken or disconnected or damaged. • Small dot on the screen caused by a weak aeria signal.
Ghost images appear.	<ul style="list-style-type: none"> • Check the Antenna direction has changed after a storm or strong wind etc. • Ghost images are caused by a signal reflected from a large building or a hill:the direction or height of the antenna should be chosen well in order to minimize the ghost images.

■ BATTERY INSTALLATION

The remote control unit operates with two 1.5V size AAA (penlight) batteries which are supplied from the factory.

1. Turn the remote control unit upside down.
Press down on the battery compartment grip and slide the cover in the direction of the arrow.
2. Install the two batteries making sure that battery polarity matches with the (+), (-) marks inside of the battery compartment.
Incorrect polarity could damage to the unit.
3. Close the battery compartment cover.

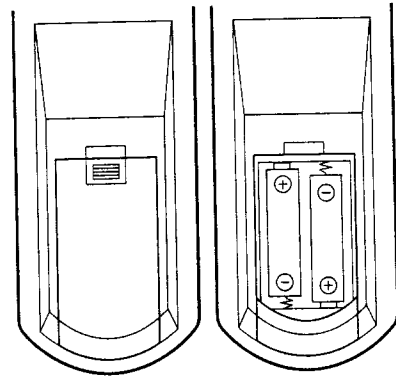

NOTE :

- The remote control unit is designed to operate within a distance of about 7 meters. If malfunction occur even though you are within the effective operating range, batteries may be weak and required replacement.
- Do not mix new and old batteries.

■ ASSEMBLY VIEW

MAIN BOARD VIEW

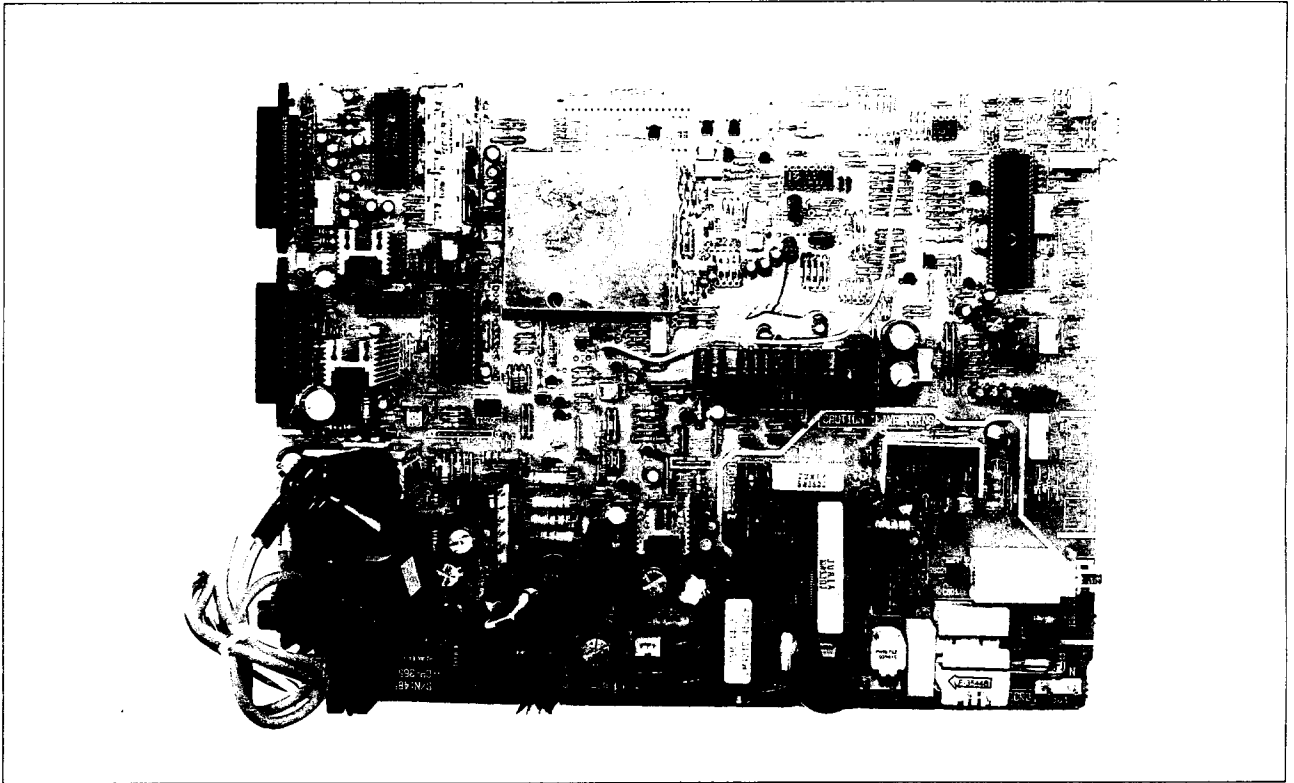

NICAM BOARD VIEW

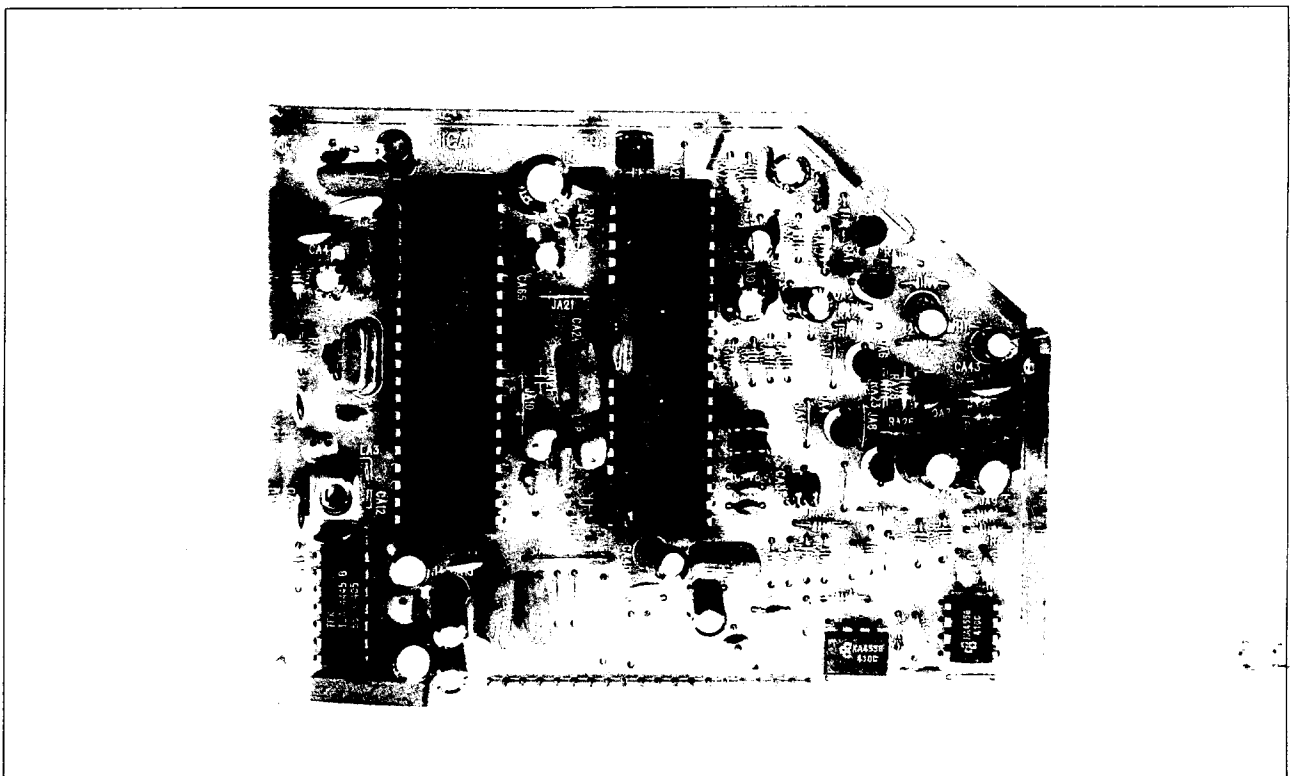

2-SOUND BOARD VIEW

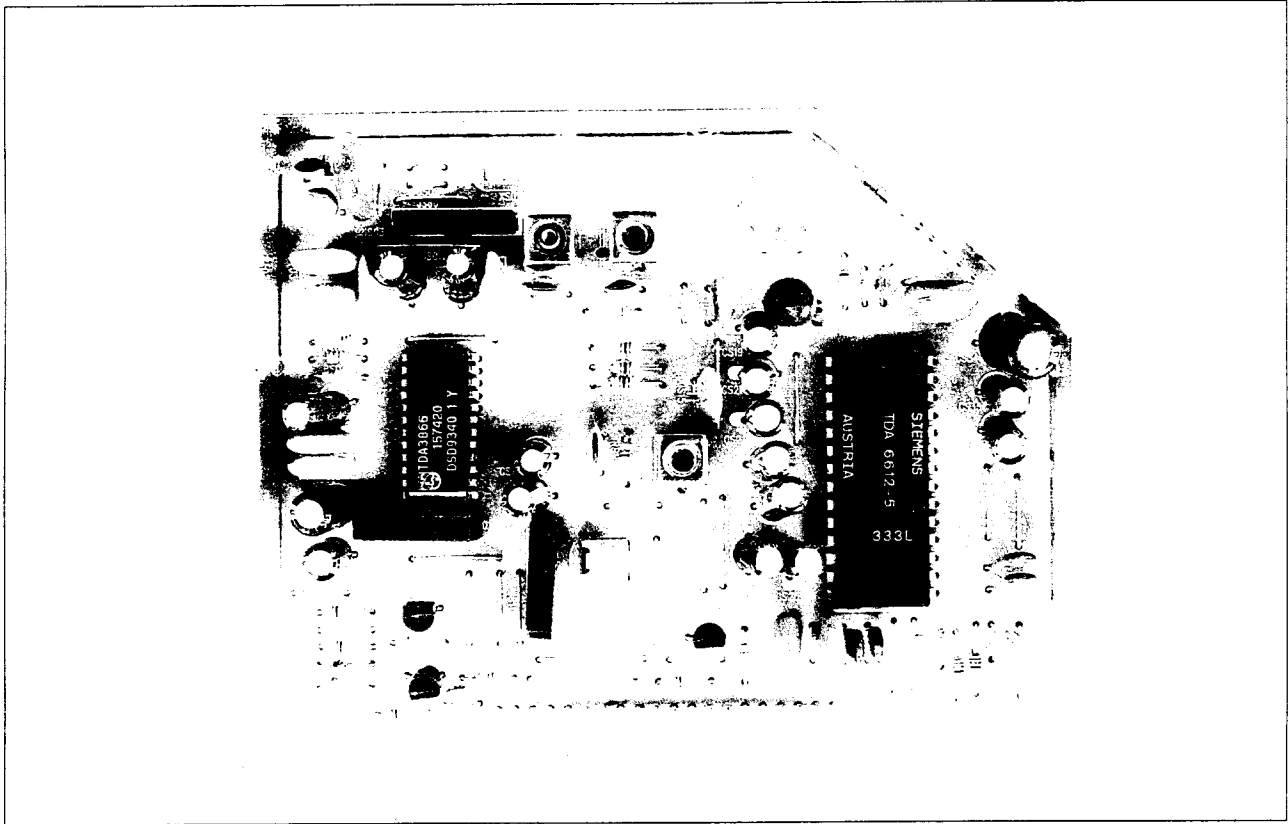

AV JACK BOARD VIEW

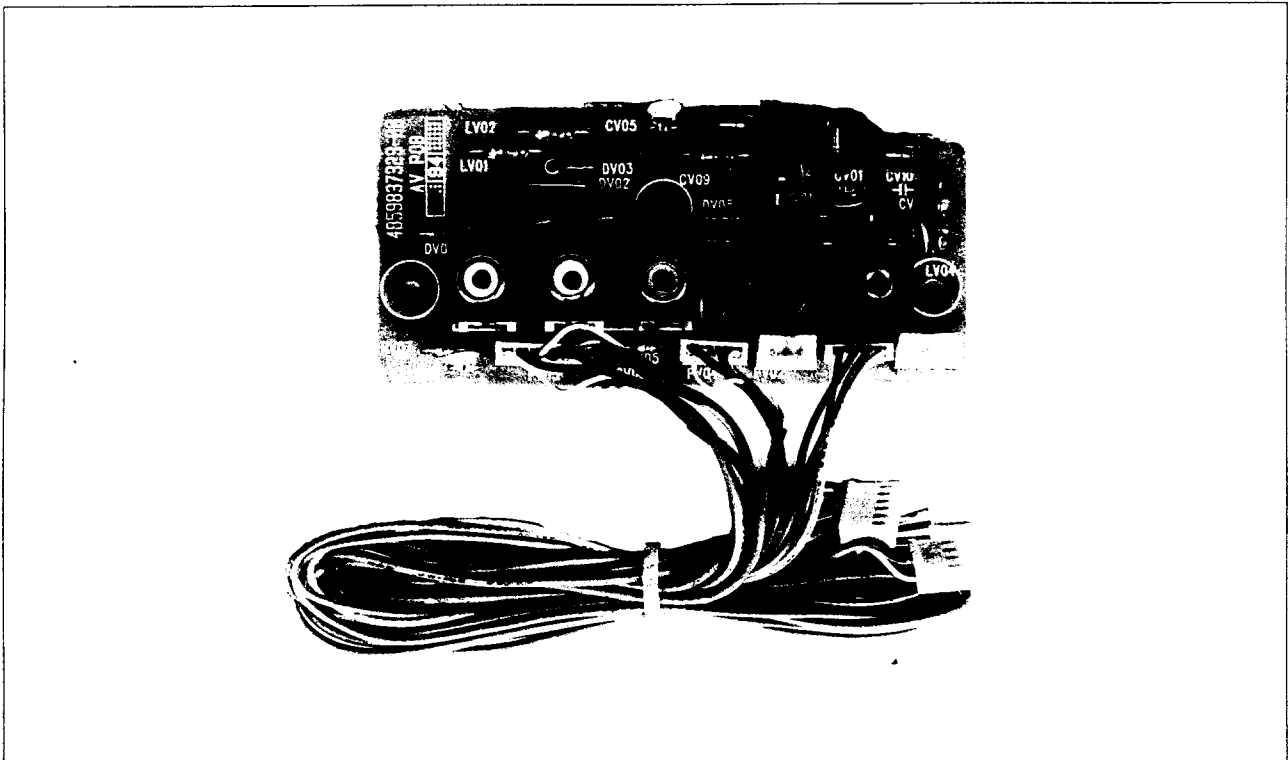

LED BOARD VIEW

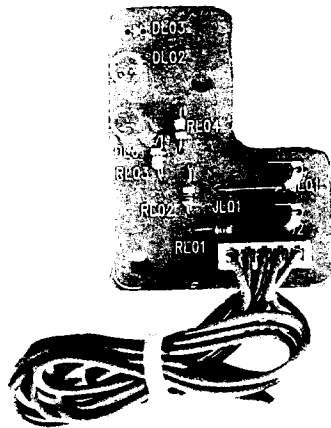

(2066, 2075)

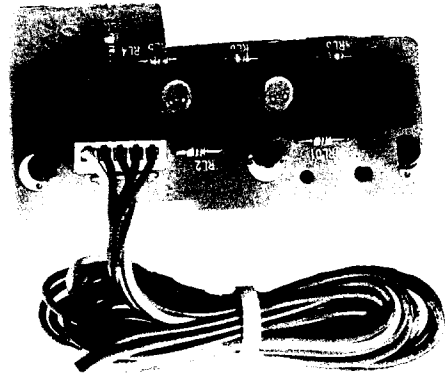

(2166)

CRT BOARD VIEW

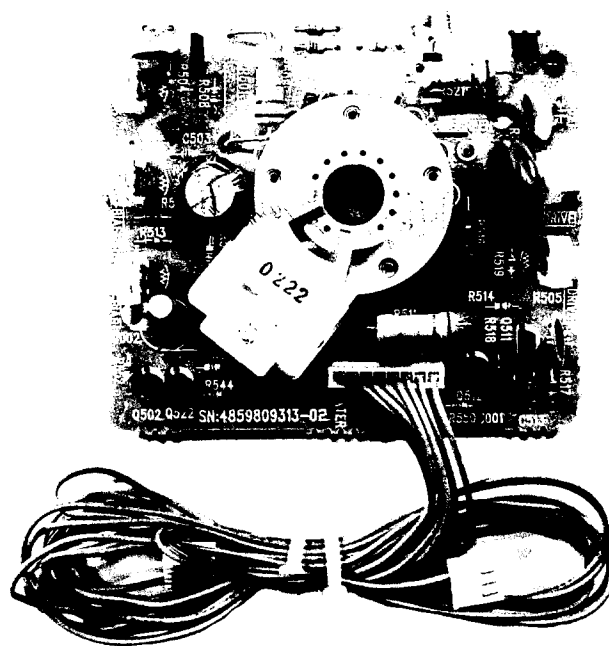

CONTROL BOARD VIEW (20CI)

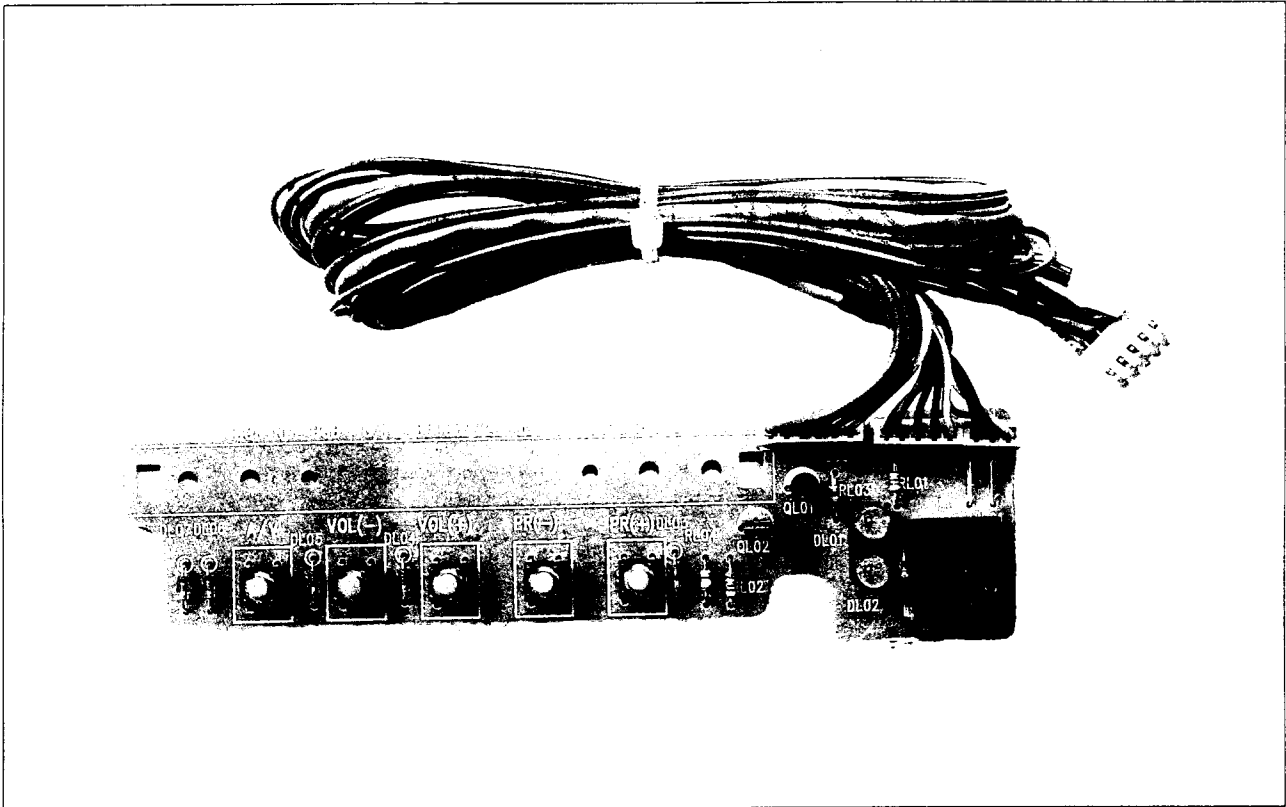

CONTROL BOARD VIEW (2195)

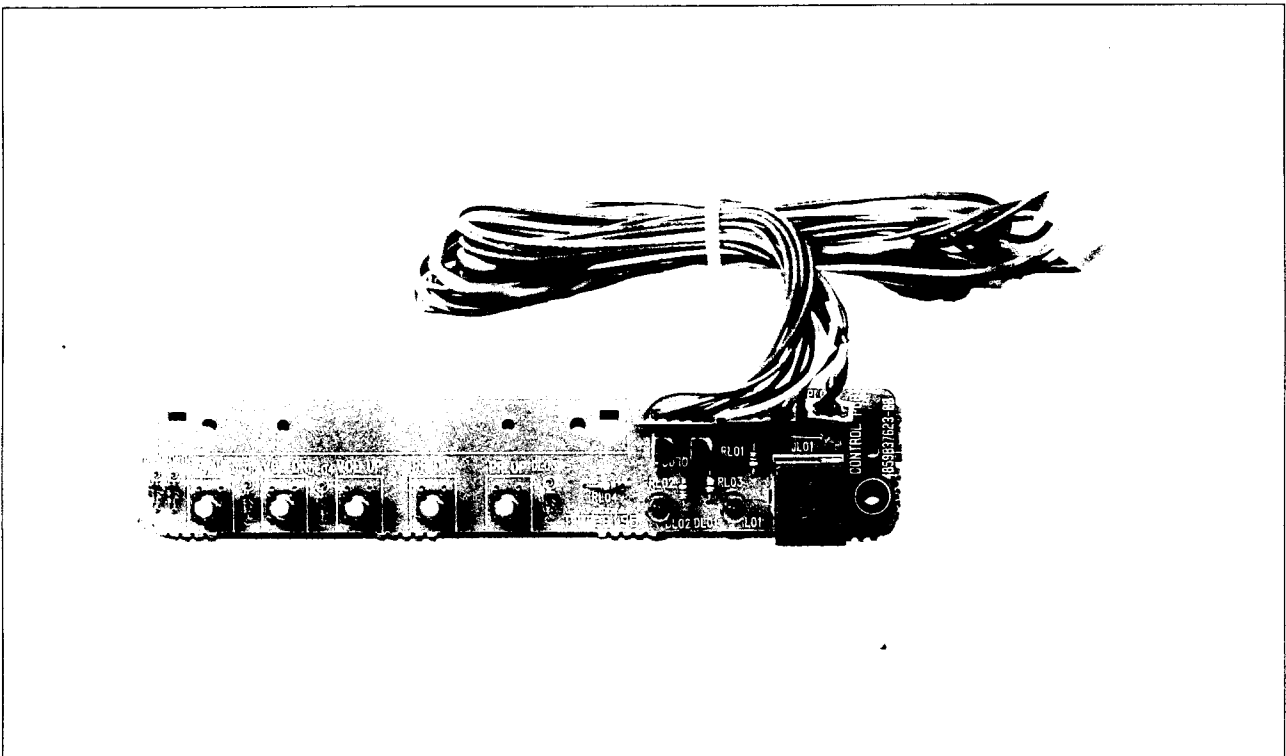

■ INSTALLATION & SERVICE ADJUSTMENTS

GENERAL INFORMATION

All adjustments are thoroughly checked and corrected when the receiver leaves the factory. Therefore the receiver should operate normally and produce proper colour and B/W pictures upon installation. But, several minor adjustments may be required depending on the particular location in which the receiver is operated. This receiver is shipped completely in a card-board carton. Carefully draw out the receiver from the carton and remove all packing materials.

Plug the power cord into a AC power outlet. Turn the receiver ON and adjust the FINE TUNING for the best picture detail. Check and adjust all the customer controls such as BRIGHTNESS, CONTRAST and COLOUR Controls to obtain a natural B/W picture.

PROTECTION CIRCUIT CHECK

1. Turn on the receiver.
2. The receiver must be turned off and changed in stand-by mode.
3. Disconnecting the resistor, the receiver should be turned on.

HIGH VOLTAGE CHECK

1. Connect an accurate high voltage metre to the anode of the picture tube.
2. Turn on the receiver. Set the BRIGHTNESS and CONTRAST controls to minimize (zero beam current).
3. High voltage should be below 27.5kv (21": 29.5kv)

AUTOMATIC DEGAUSSING

A degaussing coil is mounted around the picture tube so that external degaussing after moving the receiver is normally unnecessary. Providing the receiver is properly degaussed upon installation. The degaussing coil operates for about 1 second after the power of the receiver is switched ON. If the set is moved or placed in a different direction, the power switch must be switched off for at least 15 minutes in order to make the automatic degaussing circuit operate properly.

Should the chassis or parts of the cabinet become magnetized to cause poor colour purity, use an external degaussing coil. Slowly move the degaussing coil around the faceplate of the picture tube, the sides and front of the receiver and slowly withdraw the coil to a distance of about 2m before disconnecting it from the AC source.

If colour shading still persists, perform the COLOUR PURITY ADJUSTMENT and CONVERGENCE ADJUSTMENTS procedures, as mentioned later.

■ DYNAMIC CONVERGENCE ADJUSTMENT

Dynamic convergence (convergence of the three colour field at the edges of the CRT screen) is accomplished by proper insertion and positioning of three rubber wedges between the edges of the deflection yoke and the funnel of the CRT. This is accomplished as follows:

1. Switch the receiver on allow it to warm up for 15 minutes.
2. Apply crosshatch pattern from dot/bar generator to the receiver. Observe spacing between lines around edges of the CRT screen.
3. Tilt the deflection yoke up and down, and insert tilt adjustment wedges 1 and 2 between the deflection yoke and the CRT until the mis-convergence illustrated in figure. 2 (A) has been corrected.
4. Tilt the deflection yoke right and left, and insert tilt adjustment wedge 3 between the deflection yoke and the CRT until mis-convergence illustrated in figure. 2 (B) has been corrected.
5. Alternately change spacing between, and depth of the insertion of, the three wedges until proper dynamic convergence is obtained.
6. Use a strong adhesive tape to firmly secure latch of the three rubber wedges to the funnel of the CRT.
7. Check purity and readjust, if necessary.

■ STATIC (CENTRE) CONVERGENCE ADJUSTMENT (ORION, SAMSUNG WF CRT)

1. Switch the receiver on and allow it to warm up for 15 minutes.
2. Connect the output of a crosshatch generator to the receiver and concentrating on the centre of the CRT screen, proceed as follows:
 - a. Locate the pair of 4 pole magnet rings. Rotate individual rings (Change spacing between tabs) to converge the vertical red and blue lines. Rotate the pair of rings (maintaining spacing between tabs) to converge the horizontal red and blue lines. (Refer to fig. 1 (A))
 - b. After completing red and blue centre convergence, locate the pair of 6 pole magnet rings. Rotate individual rings (change spacing between tabs) to converge the vertical red and blue (Magenta) and green lines. Rotate the pair of rings (maintaining spacing between tabs) to converge the horizontal red and blue (Magenta) and green lines. (Refer to Fig. 1(B))

■ COLOR PURITY ADJUSTMENT (ORION, SAMSUNG WF CRT)

For the best result, it is recommended that the purity adjustment is made in final receiver location. If the receiver will be moved, perform adjustment with it's facing east. The receiver must have been operating 15 minutes prior to this procedure and the faceplate of the CRT must be at room temperature. The receiver is equipped with an automatic degaussing circuit. But, if the CRT shadow mask has come excessively magnetized, it may be necessary to degauss it with manual coil. Do not switch the coil.

The following procedure is recommended while using a dot generation.

1. Check for correct location of all neck components. (See figure. 5)
2. Rough-in the static convergence at the centre of the CRT, as explained in the static convergence procedure.
3. Rotate the picture control to centre of its rotation range, and rotate brightness control to max. CW position.
4. Apply green color signal to procedure a green raster.
5. Loosen the deflection yoke tilt adjustment wedges (3), loosen the deflection yoke clamp screw and push the deflection yoke as close as possible to the CRT screen.
6. Begin the following adjustment with the tabs on the round purity magnet rings set together, initially move the tabs on the round purity magnet rings to the side of the CRT neck. Then, slowly separate the two tabs while at the same time rotating them to adjust for a uniform green vertical band at the CRT screen.
7. Carefully side the deflection yoke backward to achieve green purity. (uniform green screen) Centre purity was obtained by adjusting the tabs on the round purity magnet rings, outer edge purity was obtained by sliding the deflection yoke forward.
Tighten the deflection yoke clamp screw.
8. Check for red and blue field purity by applying red signal and touch up adjustments, if required.
9. Perform black and white tracking procedure.

■ SCREEN & WHITE BALANCE ADJUSTMENT

1. This adjustment is to be made only after warming up at least 15 minutes.
2. Receive B/W pattern signal
3. Set the RGB Bias VR (R522, R512, R502) to MINIMUM.
4. Set the G, B Drive VR (R515, R505) to CENTER.
5. Set the CONTRAST, BRIGHTNESS, COLOR control to MIN, and Sub-brightness control to CENTER.

6. Connect a short clip to P301
7. Rotate the SCREEN control to clockwise or CCW so as to obtain dim horizontal line of one color in R, G and B.
8. Rotate the R, G and B Bias VR of the other color which did not appear on the screen clockwise, until a dim white line is obtained.
9. Rotate the Screen control gradually anti-clockwise until the last horizontal line disappears on the screen.
10. Remove the short chip and set the CONTRAST, BRIGHTNESS, COLOR control to MAX.
11. Set the G, B Drive VR to obtain the best white uniformity on the screen.
12. Rotate the CONTRAST, BRIGHTNESS, COLOR controls until a dim raster is obtained and touch-up adjustment of RGB Bias VR to obtain the best white uniformity on the screen.

■ SUB-BRIGHTNESS ADJUSTMENT

1. White balance adjustment must proceed this procedure.
2. Set the CONTRAST, BRIGHTNESS, COLOR control to MIN.
3. Rotate the SUB-BRIGHTNESS VR (VR201) gradually CCW until the last beam disappears on the screen.

■ VERTICAL HEIGHT ADJUSTMENT

1. Receive RETMA pattern signal.
2. Set the BRIGHTNESS control and CONTRAST control to Max., and the COLOR control to centre.
3. Adjust VR302 for the optimum vertical height and over scanning.

■ VERTICAL CENTER ADJUSTMENT

1. Receive RETMA pattern signal.
2. Adjust VR301 so that the vertical center of the picture may be coincident with the mechanical center of CRT.

■ HORIZONTAL CENTER CONTROL

1. Receive RETMA pattern signal.
2. Adjust VR401 so that the horizontal centre of the picture may be coincident with the mechanical centre of CRT.

■ FOCUS VOLTAGE ADJUSTMENT

1. Receive RETMA pattern signal.
2. Adjust the FOCUS VOLUME on the FBT and make the picture on the screen be finest.

RF AGC ADJUSTMENT

1. Receive PAL COLOR BAR signal in the VHF high band, where the strength of signal can be 60-65 dB.
2. Set the CONTRAST control to Max., the BRIGHTNESS control to provide adequate black and grey scales.
3. Maintain the fine tuning on the screen, and adjust VR101 (AGC DELAY CONTROL VR.) in order that it may be located on the position which the picture noise disappear on the image.

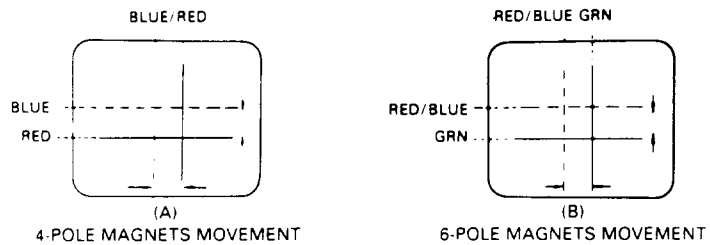

FIG. 1 CENTRE CONVERGENCE BY CONVERGENCE MAGNETS

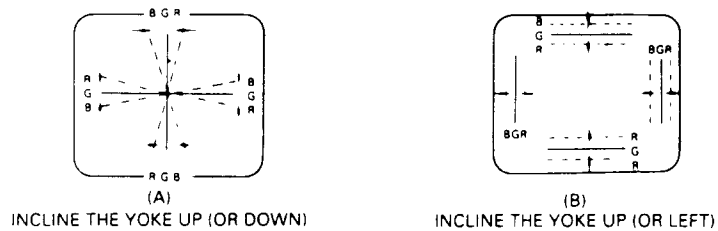

FIG. 2 CIRCUMFERENCE CONVERGENCE BY DEF. YOKE

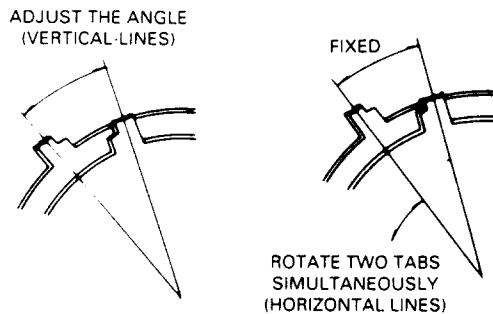

FIG. 3 ADJUSTMENT OF MAGNETS

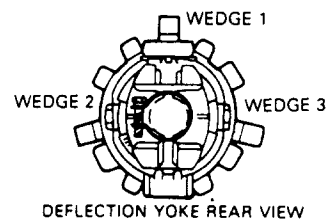

FIG. 4 RUBBER WEDGE LOCATION

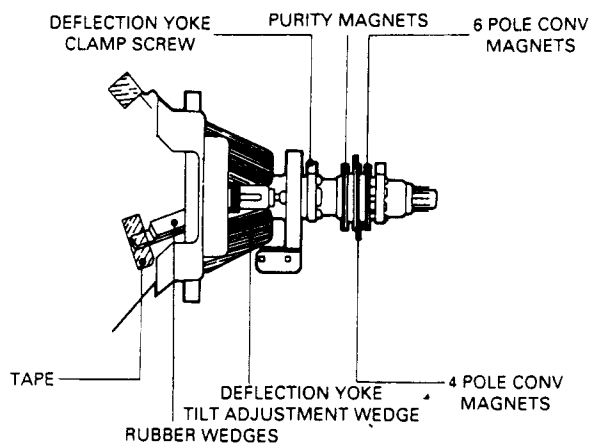

FIG. 5 PICTURE TUBE NECK COMPONENT

PIF ADJUSTMENT

I. APPARATUS CONNECTION & PRESETTING

* CONNECTION

1. Disconnect SLIT 1
2. Connect H-out of LSW-480 to X-axis of the oscilloscope and V-out of LSW-480 to Y-axis of the oscilloscope.
3. Connect the sweep signal output to TP1.
4. Set ATTENUATOR of LSW-480 to 30dB.
5. Supply 15V D.C. voltage (B+) to TP4.
6. Supply 4-5V D.C. voltage to TP3.
7. Connect wire lead between cathode of D401 & I402 #3.

* PRESET

1) Oscilloscope Scaling

- a) Put the scale of X and Y of the oscilloscope to D.C level.
- b) Set the horizontal time display to X-Y
- c) Put the horizontal axis (X) to 1V/div. and the vertical axis (Y) to 2V/div.

2) LSW-480 MARKER FREQ. SETTING.

	fp(n+1)	fs	fc	fp-2	fp	fs(n-1)
P/S-B/G,L/L'	31.9	33.4	34.47	36.9	38.9	40.4
P/S-B/G	31.9	33.4	34.47	36.9	38.9	40.4
P-I	31.9	33.5	35.07	37.5	39.5	41

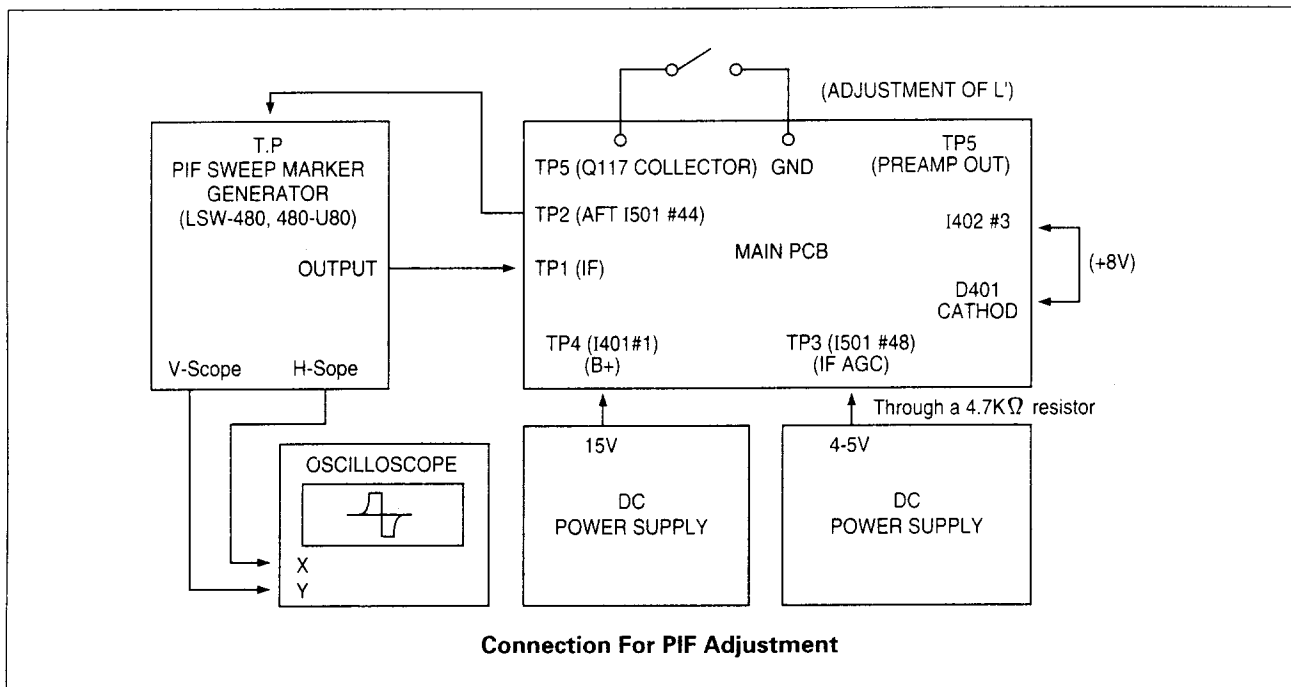

II. ADJUSTMENT OF AFT(B/G, L)

1. Connect the test point of LSW-480 to TP2.
2. Adjust L707(AFT COIL) so that the P marker point is located on the reference level.

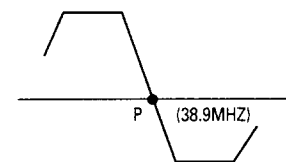

AS system is PAL-I, P carrier is 39.5 MHZ

AFT WAVEFORM

III. ADJUSTMENT OF SECAM-L' AFT

1. Connect TP5 (Q117 COLLECTOR) to GND
2. Adjust VC101 (L'AFT TRIMMER) so that the C marker point (34, 47MHZ) is located on the reference level.

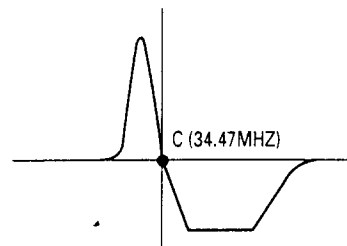

IC OPERATION DESCRIPTION

TMS73C167

(1) General Description

It is a one-chip microcontroller with an 8-bit CPU, 16K ROM, 256 bytes RAM, OSD, A/D converter, three timers (a 16 bit timer and two 8 bit timers)

(2) Block Diagram

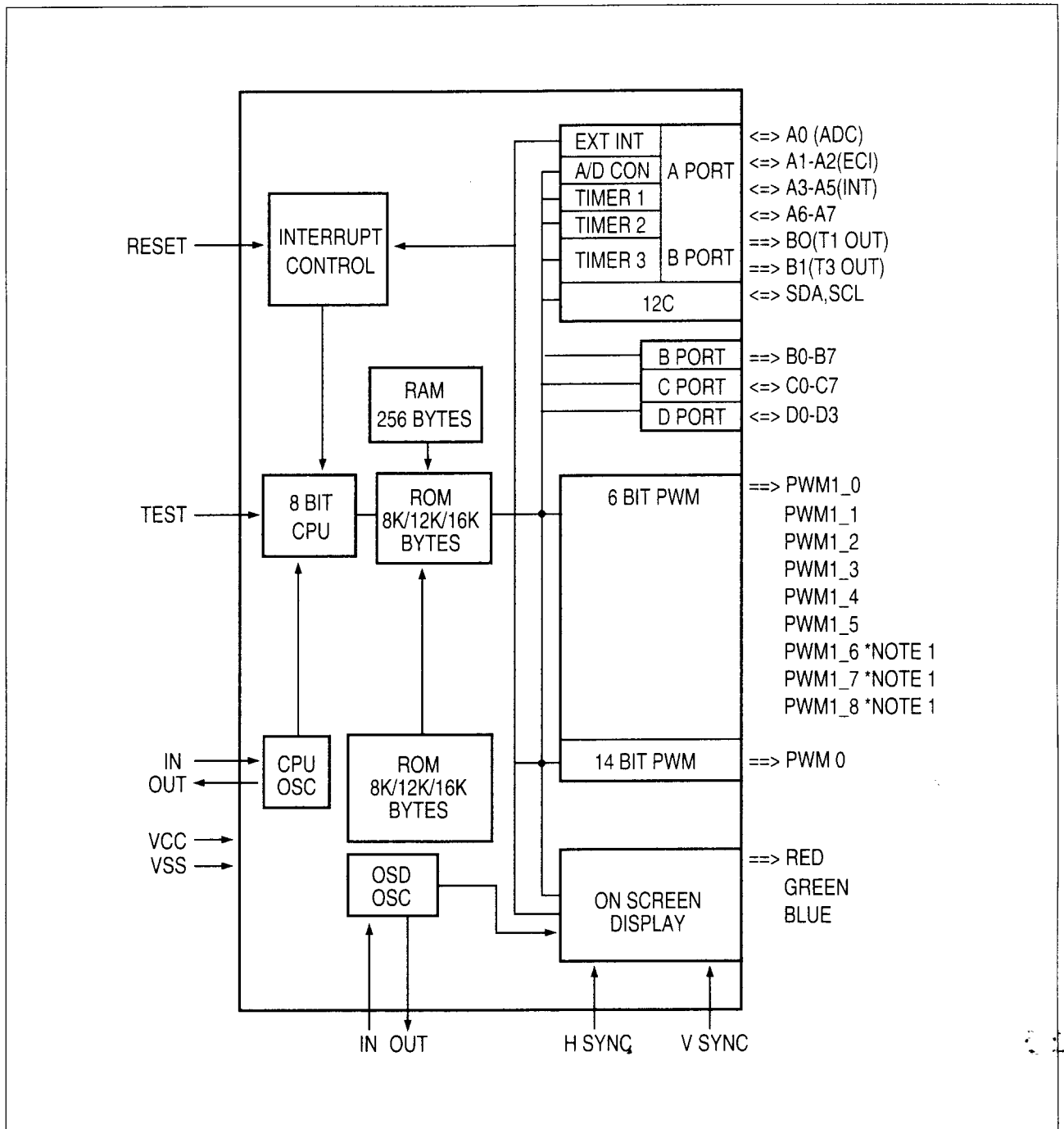

(3) Description of Terminals

Pin No.	Symbol	Name	Function Description																
1	Vt	Tuning Voltage	<ul style="list-style-type: none"> The Vt output is the pulse width modulated output of a 14 bit digital. The 14 bit data is split into two parts, the most significant 6bits and the liest significant 8 bits. The 8 bits value determines the interval of basic time. The 6 bit data decides how many TO's are added one by one in the 64 intervals. 																
2	VOL	Volume Control Output	Not used																
3	BRI	Brightness Control Output	<ul style="list-style-type: none"> Outputs the pulse width modulated signal in 63 level in accordance with 6-bit latch data (active "H") 																
4	COL	Colour control Output																	
5	CON	Contrast control Output																	
6	SHARPNESS	Sharpness Control Output																	
7	TINT	Tint Control Output																	
8	Woofer	Woofer control ON/OFF	Not used																
9	Mute	Sound Mute Control	<ul style="list-style-type: none"> Mute Output is active "H" On power on/off state, instantaneously cut off the sound. 																
10	COR	Contrast Reduction Output	Not used																
11	BL	Band Selection Output	<ul style="list-style-type: none"> There are control band signal output terminals for a tuner. Assignment for bands is as follows: <table border="1" style="margin-left: 20px;"> <thead> <tr> <th>Band</th> <th>BL</th> <th>BH</th> <th>BU</th> </tr> </thead> <tbody> <tr> <td>VHF-L</td> <td>H</td> <td>L</td> <td>L</td> </tr> <tr> <td>VHF-H</td> <td>L</td> <td>H</td> <td>L</td> </tr> <tr> <td>UHF</td> <td>L</td> <td>L</td> <td>H</td> </tr> </tbody> </table>	Band	BL	BH	BU	VHF-L	H	L	L	VHF-H	L	H	L	UHF	L	L	H
Band	BL			BH	BU														
VHF-L	H			L	L														
VHF-H	L	H		L															
UHF	L	L	H																
12	BH																		
13	BU																		
14	Hyper	Hyper Band Selection Output	Not used																
15	LED	STAND BY ON/OFF Control & REMOTE Control	<ul style="list-style-type: none"> The switch-mode power supply is controlled "L" ----- power on "H" ----- power off Remote control is received "L" ----- LED OFF "H" ----- LED ON 																
16	LED	On Timer	<ul style="list-style-type: none"> ON TIME is controlled "L" ----- LED OFF "H" ----- LED ON 																
17	SYS	System Control Output	<ul style="list-style-type: none"> This pin is used to control the sound and IF part for two different TV transmission standard. 																

Pin No.	Symbol	Name	Function Description
18	PSEUDO	System Out	<ul style="list-style-type: none"> This pin is used to control the special, pseudo stereo or only other sound effect in a stereo sound
19	AFT	4 Bit ADC Input	<ul style="list-style-type: none"> Comparison voltage input terminal connected to built-in comparator. Input AFT signal from TV with level conversion (0 to Vdd) The results of the comparison are used when the autosearch and digital AFT(described later) works.
20	KS1	Key SCAN IN/OUT1	<ul style="list-style-type: none"> Input and output pin KS1 to KS5 are used to scan to local keyboard matrix. The keyboard is scanned every 25msec; for timing, see as follows. If a key press is detected for 5 periods, it is recognized as a valid key command. The repetition of the local keyboard is 125msec, which is almost equal to the repetition time of the remote control unit.
21	KS2	Key SCAN IN/OUT2	
22	KS3	Key SCAN IN/OUT3	
23	KS4	Key SCAN IN/OUT4	
24	KS5	Key SCAN IN/OUT5	
25	OKS1	Option Key Scan Output 1	<ul style="list-style-type: none"> This pin is used to scan the various system options. An active low signal is generated at the very first switch-on ("COLD START") Local keyboard control inputs OKS1 to OKS3 are read first; all keys on the local keyboard must be released, otherwise it will wait until they are. The pins that have a diode connection to OKS are read back as 0, the pins that do not have such diode connection are read back as a logic 1.
26	OKS2	Option Key Scan Output 2	
27	OKS3	Option Key Scan Output 3	
28	GND	GND Reference	
29	DATA	DATA I/O of IMBUS	IMBUS is used to operate NICAM.
30	ID	Ident of IMBUS	
31	CLOCK	Clock of IMBUS	
32	NTSC ID	NTSC Ident Input	
33	R	OSD Red colour Output	<ul style="list-style-type: none"> Output R,G and B deliver the colour components for the OSD while output BK is used as a test blanking signal. The output polarity of the R,G,B and BK terminals are active "H".
34	G	OSD Green Colour Output	
35	B	OSD Blue Colour Output	
36	Y	Y out of OSD	
37	H-sync	H-sync input for OSD	<ul style="list-style-type: none"> Input terminal for CRT display horizontal synchronous signal. Input rectangular pulses whose amplitude is in the range from 0 to 5V. The input polarity is active "H" The signal state should be active for the time more than that required for three scanning lines.

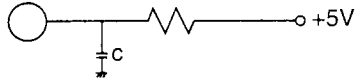
Pin No.	Symbol	Name	Function Description
38	V-sync	V-sync input for OSD	<ul style="list-style-type: none"> • Input terminal for CRT display vertical synchronous signal. • Input rectangular pulses whose amplitude is in the range from 0 to 5V. • The signal state should be active for the time more than that required for three scanning lines. The input polarity is active "H"
39	DOSCI	Clock input for OSD	<ul style="list-style-type: none"> • Input DOSC has to be connected to an external RC network which controls the oscillation frequency of the internal OSD pixel oscillator. 
40	DOSCO	Clock output for OSD	
41	ID	Sync Ident Input	<ul style="list-style-type: none"> • Input terminal of image synchronous signal necessary for auto search and AFT operation. • In the case of the determination of the level signal synchronization, the signal state ("H" of "L") which is input at this terminal is determined every 4ms. "H" ----- Presence of synchronization "L" ----- Absence of synchronization
42	GND	Ground	Should be fixed to "GND"
43	OSCI	Clock input for CPU	<ul style="list-style-type: none"> • The OSCI and OSCO are used to control the onchip oscillator of the μ-controller. • SOCI is the input terminal and OSCO the output terminal. • All internal timing of the μ-controller (except for the OSD part) are derived from this oscillator. • The oscillator frequency has to be 10MHz.
44	OSCO	Clock output for CPU	
45	RESET	Reset Input	<ul style="list-style-type: none"> • This pin is used to reset the μ-controller after a power-on reset. In order to be sure that the μ-controller starts from an initialized state after the supply voltage is available, a reset signal has to be applied. This reset signal has to be low until a stable 5V supply voltage is available.
46	S/SW	Scart Input	
47	IR	Remote Signal Input	<ul style="list-style-type: none"> • Remote control signal input terminal. • Active "L"
48	AV3	AV switching out 3	Not used
49	AV2	AV switching out 2	Not used
50	AV1	AV switching out 1	<ul style="list-style-type: none"> • Output pin AV defines whether internal audio/video signals (TV) or external signal from peripheral TV connector are selected. • When output state becomes "H", TV mode is set. When output state becomes "L", AV mode is set. It always start from TV mode.

Pin No.	Symbol	Name	Function Description
51	SDA	Data Pin for IIC(I/O)	<ul style="list-style-type: none"> • Pins SCL and SDA are respectively the data and clock wire of the multi-master two-wire bidirection IIC-bus control bus. • If a transmission does not succeed the controller will retry it for up to 5 times. If the bus is occupied for longer than 1.18 seconds the μ-controller will generate bursts of nine clock pulses with intervals of 1.18 seconds until bus is free again.
52	SCL	Clock Pin for IIC(O)	
53	POWER	Stand by ON/OFF Control Output	<ul style="list-style-type: none"> • The switch-mode power supply is controlled. "L" ----- power ON "H" ----- power OFF
54	Vcc	Power supply input terminal	<ul style="list-style-type: none"> • Connected to the 5V power supply.

TDA8362

(1) Features

- Multi-standard vision IF circuit (positive and negative modulation)
- Multi-standard FM sound demodulator (4.5 MHz to 6.5 MHz)
- Video and audio switches (CVBS int/ext, S-VHS and audio int/ext)
- Integrated chroma trap and bandpass filters (autocalibrated)
- Luminance delay line integrated
- PAL/NTSC colour decoder with automatic search system
- Easy interfacing with the TDA 8395 (SECAM decoder) for multi-standard applications
- RGB-control circuit with linear RGB inputs and fast blanking
- Horizontal synchronization with two control loops and alignment-free horizontal oscillator
- Vertical count-down circuit and vertical pre-amplifier
- Low dissipation (only 600mW)
- Small amount of peripheral components compared with competition IC's
- Only one adjustment (vision IF demodulator)

(2) Description

- Vision IF amplifier, video demodulator, video amplifier, AGC and AFC suitable for both negative and positive modulation.
 - Sound limiter, demodulator and amplifier with volume control.
 - Inputs and switches for external audio and CVBS signals.
 - Synchronization circuit with drive circuits for horizontal and vertical deflection.
 - X-ray protection (combined with the 2nd phase detector pin).
 - PAL/NTSC color decoder in which the chroma filters (bandpass and trap) and the luminance delay line have been integrated. The circuit has a separate chroma input and the filters can be switched-off so that S-VHS signals (via an external switch) can be applied to the IC.
- For SECAM applications an (alignment-free) SECAM-decoder can be added to the IC.
Peaking circuit in the luminance channel.
RGB-output circuit with linear inputs for On-screen Character Display.

(3) Block Diagram

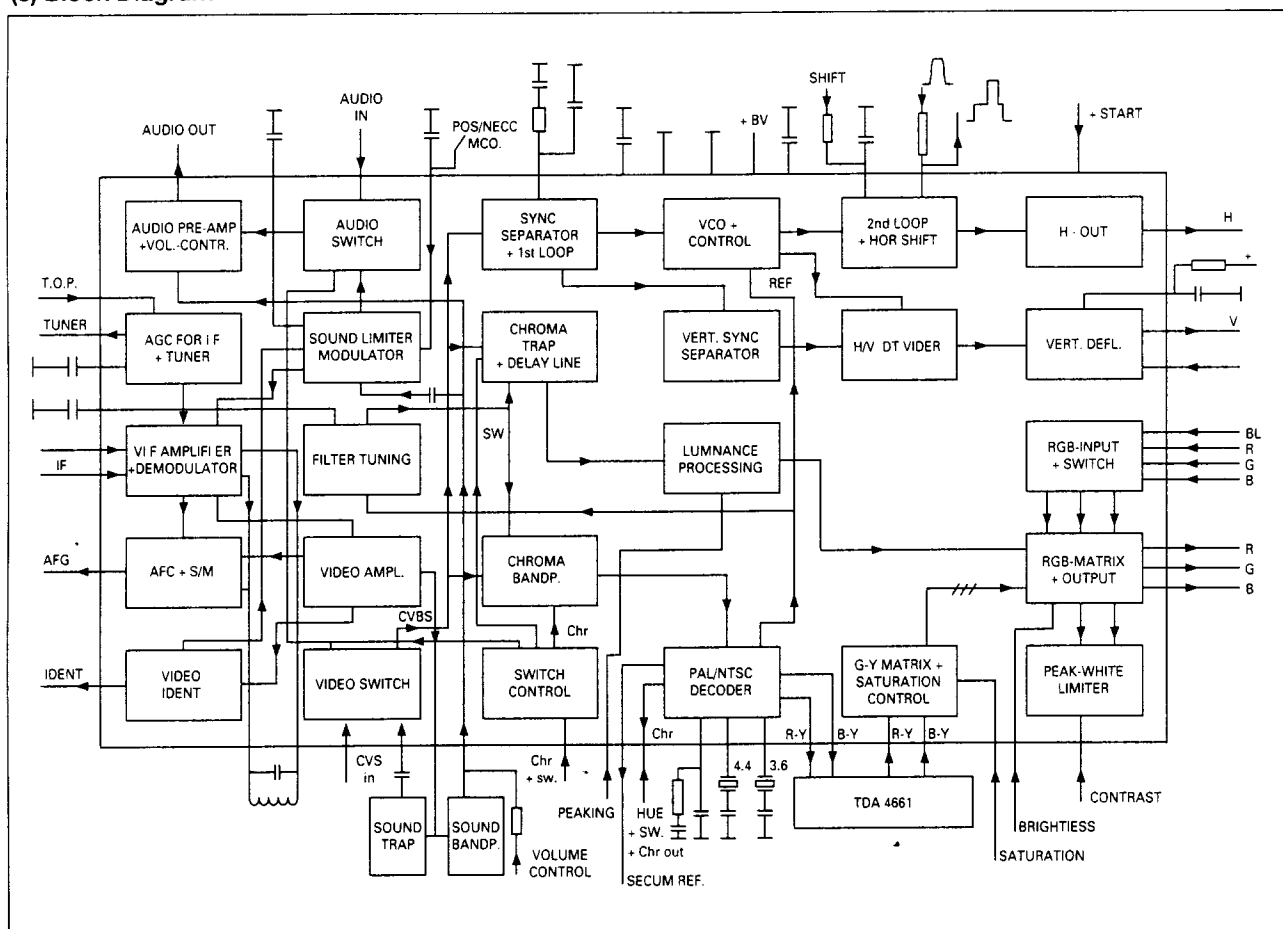

(4) Pin Description

Pin No.	Name	Function Description						
1	Audio De-emphasis	At this pin the audio signal is available for scart. The signal has an amplitude of 350mVrms (at $\delta f = 50\text{KHz}$) is non volume controlled and has to be buffered. (notice the output impedance influences the deemphasis). For scart requirements the buffer should be dimensioned as an amplifier in order to increase the output signal. A third function of this pin is the positive modulation switch. When the voltage at this pin is above $V_{cc}-1\text{V}$ positive modulation is selected. The current needed is 100 μA typical.						
2, 3	IF Demodulator Tuned Circuit	Because the demodulator performance depends on the Q factor, we want to keep the Q factor as high as possible. But this means that the steepness of the AFC will change with the Q factor of the tuned circuit itself and also with the input impedance of the IC. A compromise has to be made. The input impedance of the IC is as large as possible (about 12 kOhms) and the Q factor of normal tuned circuits varies from 70 to 90. By means of an external resistor, it is possible to damp the circuit to a Q of 40 to reduce the steepness variation of the AFC.						
4	Video Identification Output	The identification output has a three level output, 0.5, 6 or 8V. <table border="1" style="margin-left: auto; margin-right: auto;"> <tr> <td>Output voltage "video not identified"</td> <td>0.5 V max</td> </tr> <tr> <td>Output voltage "video identified" and colour signal available with $f_{sc} = 3.5 \text{ MHz}$</td> <td>6V</td> </tr> <tr> <td>Output voltage "video identified" and colour signal available with $f_{sc} = 4.4 \text{ MHz}$ or no colour signal detected</td> <td>8V</td> </tr> </table> <p>The maximum load current on this pin is 25μA. The output impedance is 20 kΩ.</p>	Output voltage "video not identified"	0.5 V max	Output voltage "video identified" and colour signal available with $f_{sc} = 3.5 \text{ MHz}$	6V	Output voltage "video identified" and colour signal available with $f_{sc} = 4.4 \text{ MHz}$ or no colour signal detected	8V
Output voltage "video not identified"	0.5 V max							
Output voltage "video identified" and colour signal available with $f_{sc} = 3.5 \text{ MHz}$	6V							
Output voltage "video identified" and colour signal available with $f_{sc} = 4.4 \text{ MHz}$ or no colour signal detected	8V							
5	SIF input +Volume control	The sound input impedance is 8.5k Ω /5pF which has to be taken into account for the ceramic filters. For DC, the impedance is very high. The PLL is sensitive for high freq. AC signal > 1mVrms. Because of the chosen principle: an adjustment free PLL it is needed to have an internal PLL with a large bandwidth (catching range). This implies system also is sensitive for spurious frequencies. Both layout and sound band pass filters need special attention. The volume can be controlled at this pin by means of a DC voltage of 0.2-5V for min-max gain.						
6	External Audio Input	External sound signals from scart, for example, can be applied to this pin via a capacitor. The input impedance is 25k Ω .						
7	IF Video Output	A multistandard concept requires several filters at the video output (sound-trap and sound-band pass filters). This causes a too big capacitive load at the video output so an EMITTER FOLLOWER as buffer should be added. The required emitter current depends on the number of filters applied.						
8	Decoupling digital Supply	Decoupling Digital Supply						
9	Ground	Ground 1 (IF, H sync, RGB output, Digital, H output)						
10	Positive Supply (8V)	Supply (IF, Sound, H sync, Chroma, Filters, RGB output, Digital)						
11	Ground	Ground 2 (Sound, Chroma, Filters, Hosc, PHI-1, PHI-2)						

Pin No.	Name	Function Description																												
12	Decoupling filter tuning	Variations in the tuning voltage outside calibration (i.e. during field scan), due to external leakage current or interference sources, will result in mistuning of the luminance notch filter, chroma bandpass filter and luminance delay stage. Unwanted voltage signals at pin 12 due to external leakage currents or crosstalk from interference sources should be less than 100mV. A capacitor of 100nF requires that external leakage currents at pin 12 should be less than 0.5µA.																												
13	Internal CVS input	The internal and external CVBS amplitudes should be $2V_{pk-pk}$ and $1V_{pk-pk}$ respectively; their source impedances should be low so as to minimize crosstalk from interference sources. The internal CVBS input is derived from the IF video output (pin 7) and the external CVBS input can be derived from either SCART CVBS or YSVHS; they should be AC coupled to pins 13 & 15 respectively. The coupling capacitors are chosen in order to have fast clamping and minimum line/field sag.																												
15	External CVS input																													
14	Peaking control input	The input impedance of pin 14 is very high (MOS input). The DC voltage at the peaking control input controls the gain of the peaking amplifier. The peaking control input voltage should have a DC voltage range from 0 to 5V.																												
16	AV switch input + Chroma (SVHS) input	The input impedance of the chroma and AV switch input (pin 16) is 15kΩ in parallel with 5pF. A DC voltage on this pin controls the internal/external CVBS and AUDIO selection where the following table gives the various possibilities:																												
		<table border="1"> <thead> <tr> <th>Vpin 16 (dc)</th> <th>Internal CVBS</th> <th>External CVBS/Y</th> <th>CSVHS signal</th> <th>Luminance notch</th> <th>Audio signal</th> <th>Model</th> </tr> </thead> <tbody> <tr> <td>< 0.5V</td> <td>on</td> <td>off</td> <td>off</td> <td>on</td> <td>Internal</td> <td>TV</td> </tr> <tr> <td>Between 3V & 5V</td> <td>off</td> <td>on(Y)</td> <td>on</td> <td>off</td> <td>External</td> <td>S VHS</td> </tr> <tr> <td>> 7.5V</td> <td>off</td> <td>on (CVBS)</td> <td>off</td> <td>on</td> <td>External</td> <td>AV</td> </tr> </tbody> </table>	Vpin 16 (dc)	Internal CVBS	External CVBS/Y	CSVHS signal	Luminance notch	Audio signal	Model	< 0.5V	on	off	off	on	Internal	TV	Between 3V & 5V	off	on(Y)	on	off	External	S VHS	> 7.5V	off	on (CVBS)	off	on	External	AV
Vpin 16 (dc)	Internal CVBS	External CVBS/Y	CSVHS signal	Luminance notch	Audio signal	Model																								
< 0.5V	on	off	off	on	Internal	TV																								
Between 3V & 5V	off	on(Y)	on	off	External	S VHS																								
> 7.5V	off	on (CVBS)	off	on	External	AV																								
17	Brightness Control input	The brightness control voltage present at pin 17 controls the dc level of the RGB outputs where a brightness control voltage of 0 → 5V at pin 17 results in a black level shift at the RGB outputs of ±1V about the nominal.																												
18 19 20	B-output G-output R-output	The RGB output signals are supplied to the video output stages. For nominal input signals (i.e. CVBS and -(R-Y)/-(B-Y) signals) and for nominal gain settings then the RGB output signal amplitudes (black-to-white) are typically 4V with a black level at approximately 1.3V. The blanking level is 0.8V and maximum peak white level is 6.0V. Since the RGB output stages are made with emitter followers, the maximum sink current is limited to 1.5mA. Therefore the current delivered from the video output stages to the RGB pins must not exceed 1.5mA. When the RGB switch control (pin 21) voltage exceeds 4V then the RGB outputs are blanked and consequently on-screen display signals (OSD) can be supplied to the video output stages.																												

Pin No.	Name	Function Description
21	RGB insertion + Blanking input	The RGB insertion signals are selected by means of a fast switch control. With the conditions that: $0.8V < V_{pin21} < 3.1V$ then the RGB insertion signals are selected. And input voltage to blank the RGB-outputs so that OSD signals can be applied to these outputs is 4.5V (min).
22 23 24	R-input for insertion G-input for insertion B-input for insertion	The RGB insertion signal information is coupled via 100nF to pins 22, 23 and 24 respectively. The coupling/clamping capacitors should always have a low impedance path to ground for proper clamping operation.
25	Contrast Control Input	The contrast control input of $0 \rightarrow 5V$ at pin 25 gives a 20dB gain range at the RGB outputs. When one of the RGB output signals exceed 6V, it is then clipped to 6V and also the gain of the RGB output amplifiers can be reduced by adapting the contrast voltage using the peak white limiter (PWL) current. The PWL current during PWL operation is 100 μ A.
26	Saturation Control Input	The saturation control input voltage, present at pin 26, is $0 \rightarrow 5V$. this corresponds to a 52dB gain range of the $-(R-Y)/-(B-Y)$ signals.
27	Chroma output + Hue Control Input	If the $V_{pin27} > 6v$, the ASM does not search for NTSC signals and the decoder application can only be PAL or PAL/SECAM. The output impedance with an external resistance of 22k Ω to 8V is then approximately 500 Ω . The hue control input pin should be provided with a voltage of 0 to 5V for NTSC decoder applications; within this voltage range the input impedance is very high (MOS input).
28 29	B-Y input R-Y input	The $-(R-Y)/-(B-Y)$ signals, present at pins 11 and 12 of the TDA4661, are coupled via 100nF (these capacitors are also clamping capacitors) to pins 29 and 28. The maximum input current of both pins is 1 μ A. With 100nF coupling capacitors the voltage drop over a line period is less than 0.5mV. Since the output impedance of pin 11 and 12 of the TDA 4661 is maximal 400 Ω then the signal tracks between the TDA4461 and the TDA8362 should have good ground shielding and be as short as possible.
30 31	R-Y output B-Y output	The output impedance of pins 30 & 31 is approximately 250 Ω when PAL/NTSC signals are identified. For SECAM signals the output impedance is very high (output switch is open) and any external circuitry is not loaded (i.e. the demodulator outputs of the TDA8395). During the line/field blanking periods of the sandcastle pulse, the demodulator outputs are set to the correct dc levels so as no offsets exist. The $-(R-Y)/-(B-Y)$ outputs are coupled, via 1nF, to pins 16 & 14 of the TDA4661 respectively.
32	4.43 MHz output for TDA8395	A SECAM reference signal (4.43 MHz only) is delivered directly from pin 32 of the TDA8362 to pin 1 of the TDA8395. When SECAM signals are identified by the TDA8395, it withdraws a current of 150 μ A from pin 32. The SECAM interface communicates the ident information via this current to the ASM. If PAL/NTSC signals are not already identified by the ASM and the identified signal is 50 Hz then an acknowledge will be given by the ASM to the TDA8395 by setting the voltage at pin 32 to 5V. With SECAM identified, the SECAM reference signal is gated and present at pin 32 only during the field retrace period. When PAL/NTSC is identified, the output level is 1.5V.

Pin No.	Name	Function Description
33	Loop Filter (Burst Phase Detector)	<p>One of the important aspects of the PLL is the loop filter connected to pin 33. It ensures that the PLL synchronizes the VCXO, in both frequency and phase, with the incoming burst (average burst for PAL standards). It also determines the dynamic performance of the loop where the important parameters are:</p> <ul style="list-style-type: none"> - Noise immunity - Transient response - Acquisition behaviour <p>The remaining aspects of the PLL/VCXO are static phase error and X-tal type used at pins 34 or 35. For small static phase errors (less than 5°) the requirements are:</p> <ul style="list-style-type: none"> - The combined burst phase detector and VCXO sensitivity are high - The offset of the burst phase detector output is small - The external leakage current at pin 33 is small <p>The TDA8362 determines the first two; the third is determined by the external leakage resistance of pin 33 to ground. Deviations in the VCXO free running frequency due to X-tal or X-tal load capacitance spreads have negligible influence on the static phase error because the combined phase detector and VCXO sensitivity is high. The static phase error is due to the internal offset of the phase detector output and the external leakage current at pin 33. Static phase errors much less than 5° were measured.</p>
34 35	3.58MHz X-TAL Connection 4.43MHz X-TAL Connection	To ensure correct operation of both colour processing and sync calibration circuits in the TDA8362, 4.43 X-tals must not be connected to pin 34 and 3.58 X-tals must not be connected to pin 35.
36	Start Horizontal Oscillator	<p>The minimum current required for the start function is 6.5mA, then the voltage will be approx. >7.2V. The voltage at pin 36 may not exceed 8.8V, so depending on the application external clamping is necessary.</p> <p>If the start voltage is below approximately 5.8V then the horizontal output will be disabled.</p> <p>The decoupling should be sufficient because the start pin supplies the circuitries needed for the horizontal output. (The oscillator references however, are supplied by the bandgap)</p> <p>This pin must be connected directly to the supply pin when no start function is used.</p>
37	Horizontal Output	This open collector output drives the horizontal output stage. The maximum allowable current is 10mA. The saturation voltage then will be 0.3V.
38	Flyback input +Sandcastle Output	<p>A sandcastle signal is available at this pin for external use. The signal levels are:</p> <ul style="list-style-type: none"> Burst typ 5.3V, the output impedance is approx. 1kΩ Flyback typ 3 V, impedance defined by the flyback circuit. Field blanking typ 2 V, the output impedance is approx. 4kΩ <p>The flyback input signal is used for the PHI-2 loop and RGB line blanking Pin 38 requires a current of only a few μA in order to reach the 3V flyback clamping level. Detection of the flyback pulse (and thus RGB blanking) only occurs when the input current is at least 100μA. (The maximum allowable current is 300μA.)</p> <p>Additional remarks:</p> <ul style="list-style-type: none"> - Due to an internal base current at pin 38, the voltage level becomes 3V when the pin is not loaded. - During start-up pin 38 is forced low by 2mA.

Pin No.	Name	Function Description
39	ø-2 loop Filter + X-Ray Protection	The phase error on screen due to storage time variations depends on the PHI-2 loopgain. In principle this figure is fixed but will decrease when an additional resistor comes in parallel to the capacitor at pin 39. The time constant is defined by the external capacitor. The voltage to switch on the X-ray protection is 6V. (min.)
40	ø-1 loop Filter	The PHI-1 behaviour depends on both the loop filter externally connected at pin 40 and the PHI-1 output currents. The PHI-1 output current has been made switchable during scan (a fixed current ratio) in order to avoid the need of switching the loop filter for normal-and noisy-signals. This implies the loop filter can be optimised for both VCR-and noisy-signals.
41	Vertical Feedback Input	The feedback signal is derived by sensing the deflection coil current by means of a resistor. The feedback signal is related to the vertical ramp signal. The ramp amplitude should be 1Vpp while the DC level is 2.5V typical. The guard levels are 1 and 4Vtyp. In order to filter horizontal into a capacitor is mounted at the input.
42	Vertical Ramp Generator	The vertical ramp is defined as: <ul style="list-style-type: none"> - DC clamping voltage of 2V - AC amplitude of 1.5Vpp for a 50Hz field signal - AC amplitude of 1.25Vpp for a 60Hz field signal <p>The AC amplitude of 1.5V is important for optimal pre-correction and 50/60Hz gain correction.</p>
43	Vertical Output	The vertical drive output is fed to the deflection-IC. The available output current is minimal 1mA, and the available output voltage is 4-5V. During retrace the drive output has to be constant and equal to the low level of 0.3V.
44	AFC Output	The AFC steepness can be influenced by the Q of the tuned circuit and output resistors at the AFC output pin (60kΩ output impedance internally). Due to current reserve the steepness can be reduced by a factor 4-5 while the output voltage swing remains 6V. Some small video information can still be present at the AFC output pin although a S&H function is applied. This video information can be filtered by an external capacitor at this pin. The AFC output voltage changes from approximately 0.5-6.3V. The output impedance of AFC circuit is 50kΩ.
45,46	IF Input	DC coupling is allowed, so no series capacitors are necessary. The circuit matches the required load impedance for commonly used SAW filters (2k/3pF).
47	Tuner AGC Output	The tuner AGC is an open collector output which is acting as a variable current source to ground. Normally the output application circuit is designed for an output current swing of 1-2mA. In order to improve the dynamical behaviour during channel switching it is possible to sink with a current of approximately 12mA maximal. The max voltage is Vcc+1V.
48	AGC Decoupling Capacitor	Increasing of the AGC time constant is achieved by increasing the AGC capacitor on pin 48. Increasing this capacitor also results in an improvement in the catching and holding range of the ident circuit.

Pin No.	Name	Function Description
49	Tuner Take-Over Adjustment	<p>The control range at this pin is 0.5-4.5V.</p> <p>Characteristics: The tuner take over adjust voltage versus IF input signal is a linear function with a slope of approximately 20mV/dB. (Measured at an AGC output current of 1mA) In order to achieve a stable AGC control at strong signals a decoupling capacitor of at least 1nF at this pin is required.</p> <p>Alignment: With the potentiometer connected to pin 49 of the TDA8362, the tuner take over point can be adjusted when an RF signal is applied to the aerial input of the tuner.</p>
50	Audio Input	<p>The DC output voltage is 3.3V.</p> <p>The volume controlled output signal is AC coupled to the sound output amplifier. The output impedance is 250Ω.</p>
51	Decoupling Sound Demodulator	<p>This pin defines the DC voltage at the deemphasis and sound output. The pin forms a low pass filter in the DC feedback loop. This implies that the sound amplitude for lower frequencies, < f_k, is attenuated. A bigger capacitor, in order to decrease f_k, is allowed but increases the DC setting time.</p>
52	Decoupling Bandgap Supply	Decoupling Bandgap Supply

TDA4661 (Base Band Delay Line)

(1) Features

- Two comb filters, using the switched-capacitor technique, for one line delay time (64µs)
- Adjustment free application
- No crosstalk between SECAM colour carriers (diaphoty)
- Handles negative or positive colour-difference input signals
- Clamping of AC-coupled input signals ($\pm(R-Y)$ and $\pm(B-Y)$)
- VCO without external components
- 3MHz internal clock signal derived from a 6MHz VCO, line-locked by the sandcastle pulse (64 µs line)
- Sample-and-hold circuits and low-pass filters to suppress the 3 MHz clock signal
- Addition of delayed and non-delayed output signals
- Output buffer amplifiers
- Comb filtering functions for NTSC colour-difference signals to suppress cross-colour

(2) General Description

The TDA4661 is an integrated baseband delay line circuit with one line delay. It is suitable for decoders with colour-difference signal outputs $\pm(R-Y)$ and $\pm(B-Y)$.

(3) Block Diagram

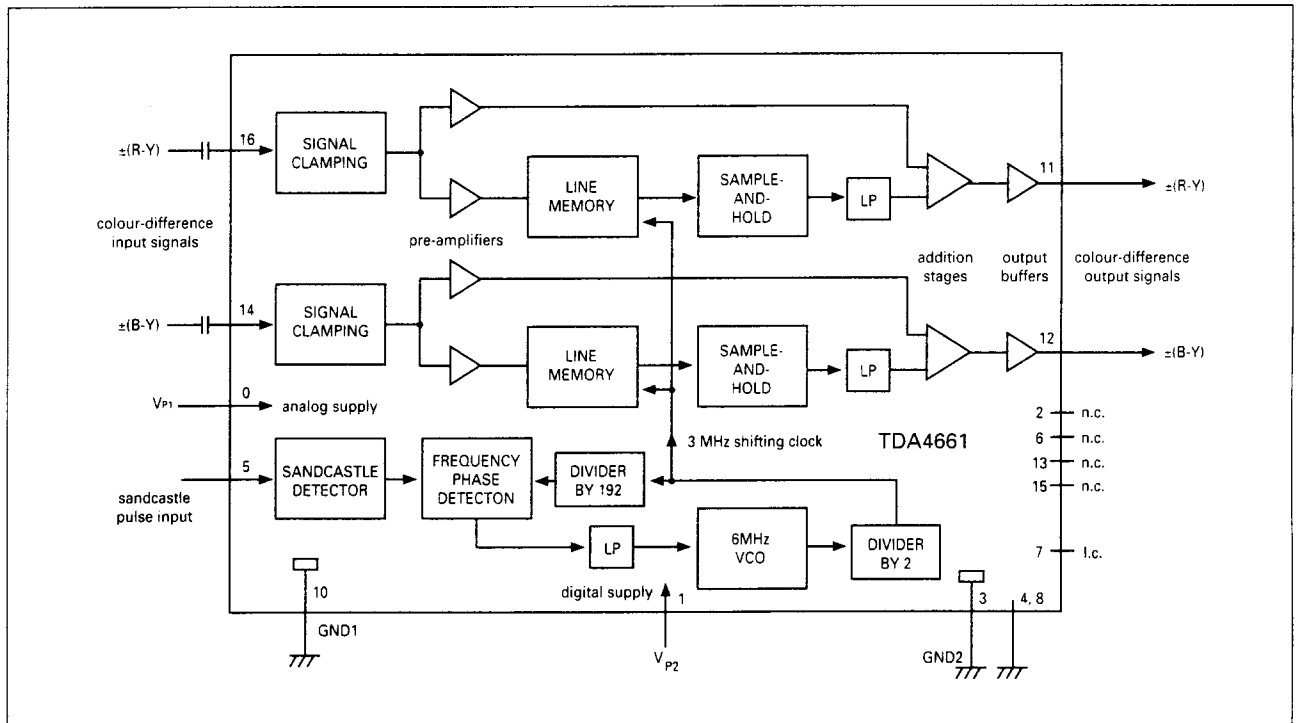

(4) Pin Description

SYMBOL	PIN	DESCRIPTION
V _{p2}	1	+5V Supply Voltage for Digital Part
n.c.	2	Not Connected
GND 2	3	Ground for Digital Part (0 V)
i.c.	4	Internally Connected
SAND	5	Sandcastle Pulse Input
n.c.	6	Not Connected
i.c.	7	Internally Connected
i.c.	8	Internally Connected

SYMBOL	PIN	DESCRIPTION
V _{p1}	9	+5V Supply Voltage for Analog Part
GND 1	10	Ground for Analog Part (0 V)
V _o (R-Y)	11	\pm (R-Y) Output Signal
V _o (B-Y)	12	\pm (B-Y) Output Signal
n.c.	13	Not Connected
v _i (B-Y)	14	\pm (B-Y) Input Signal
n.c.	15	Not Connected
V _i (R-Y)	16	\pm (R-Y) Input Signal

TDA8395 (Secam Decoder)

(1) Features

- Fully integrated filters
- Alignment free
- For use with baseband delay

(2) Description

The TDA8395 is a self-calibrating, fully integrated SECAM decoder. The IC should preferably be used in conjunction with the PAL/NTSC decoder TDA8362 and with the switch capacitor baseband delay circuit TDA4661. The IC incorporates HF and LF filters, a demodulator and an identification circuit (luminance is not processed in this IC). A highly stable reference frequency is required for a calibration and a two-level sandcastle pulse for blanking and burst gating.

(3) Block Diagram

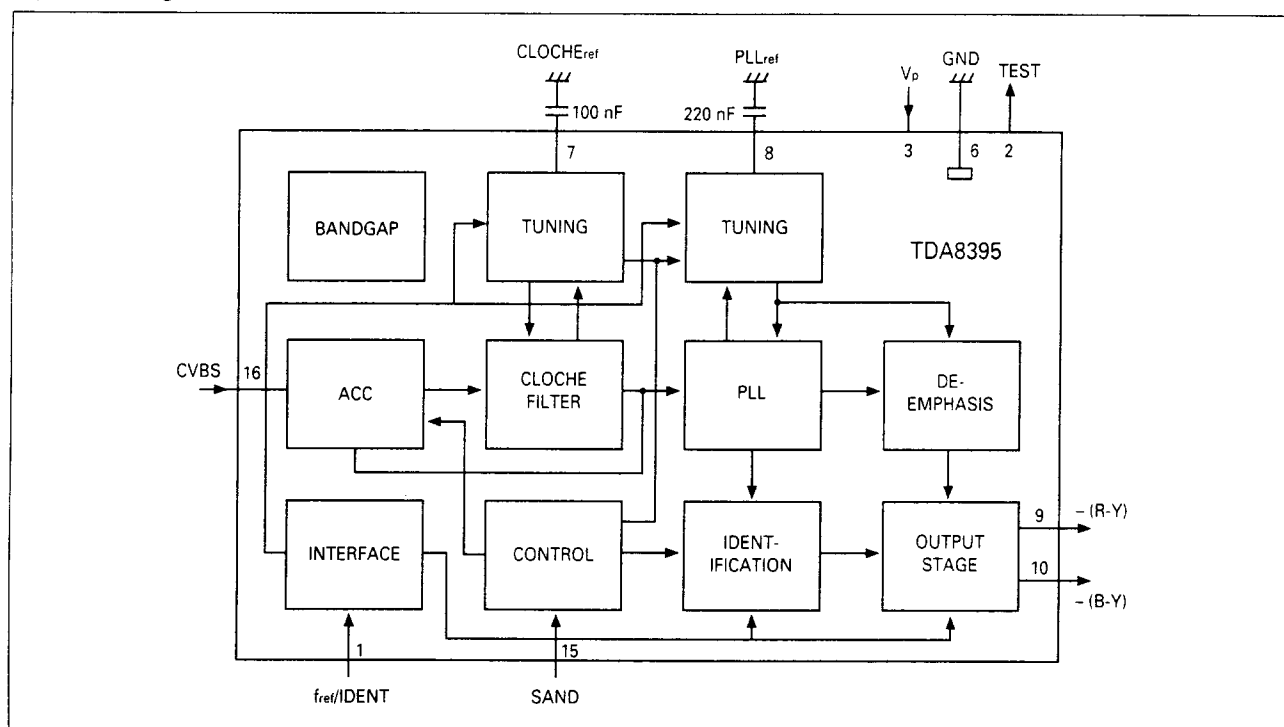

(4) Pin Description

SYMBOL	PIN	DESCRIPTION
f _{ref} /IDENT	1	Reference Frequency Input/Identification Input
TEST	2	Test Output
V _p	3	Positive Supply Voltage
n.c.	4	Not Connected
n.c.	5	Not Connected
GND	6	Ground
CLOCHE _{ref}	7	Cloche Reference Filter
PLL _{ref}	8	PLL Reference
-(R-Y)	9	-(R-Y) Output
-(B-Y)	10	-(B-Y) Output
n.c.	11	Not Connected
n.c.	12	Not Connected
n.c.	13	Not Connected
n.c.	14	Not Connected
SAND	15	Sandcastle Pulse Input
CVBS	16	Video (chrominance) Input

TDA7263M (12+12W Stereo Amplifier with Muting)

(1) Features

- Wide supply voltage range
- High output power
- Mute facility with low consumption
- Ac short circuit protection
- Thermal overload protection

(2) General Description

The TDA7263M is class AB dual audio Power amplifier assembled in the multi watt package, specially designed for high auality sound application as Hi-Fi music centers and stereo TV sets.

(3) Block Diagram

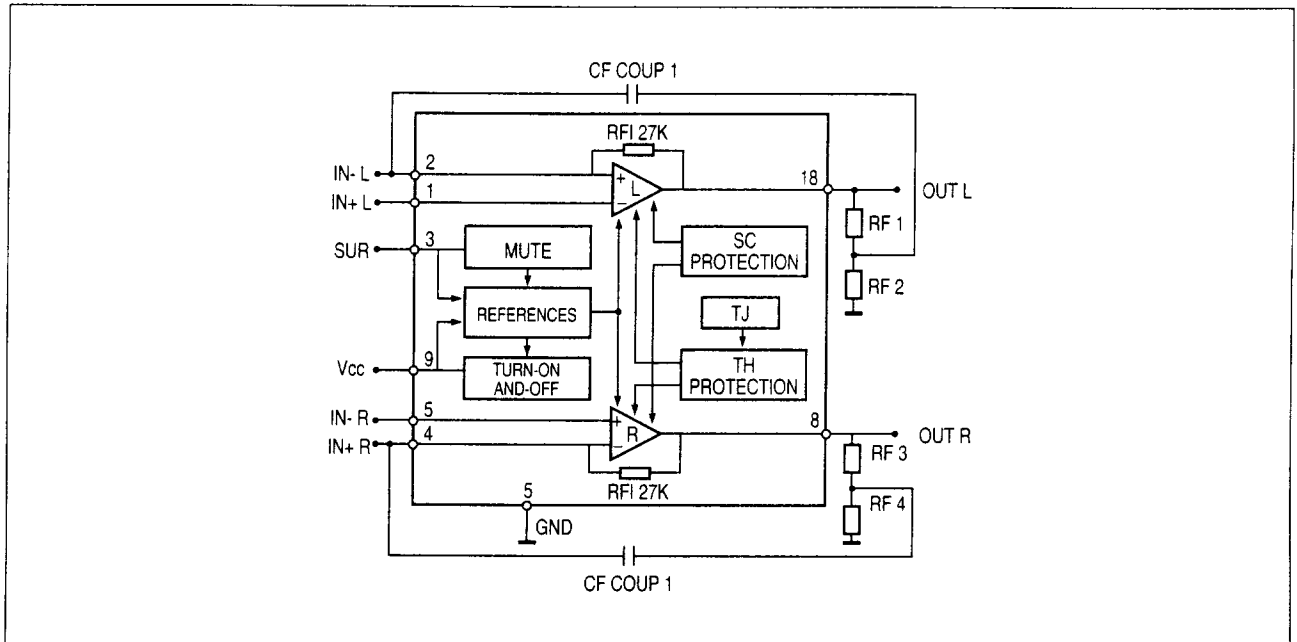

(4) Pin Description

PIN	DESCRIPTION
1	Non Inverting Input 1
2	Inverting Input 1
3	Sur/Muting
4	Inverting Input 2
5	Non Inverting Input 2
6	GND
7	N.C.
8	Output 2
9	Vcc
10	Output 1
11	N.C.

AT24C08PC (EEPROM)

(1) Features

- IC Bus compatible
- Low power CMOS Technology
- 16 Byte page write Buffer
- Self-Timed write cycle with Auto-Clear
- 100,000 program/Erase cycles
- 100 Year Data Retention
- Optional High Endurance Device Available

(2) General Description

The AT24C089C is a 8K bit serial CMOS E²PROM internally organized as 1024x8bits. Catalyst's advanced C MOS technology substantially reduces device power requirements. The AT24C08PC features a 16 byte page write buffer.

(3) Block Diagram

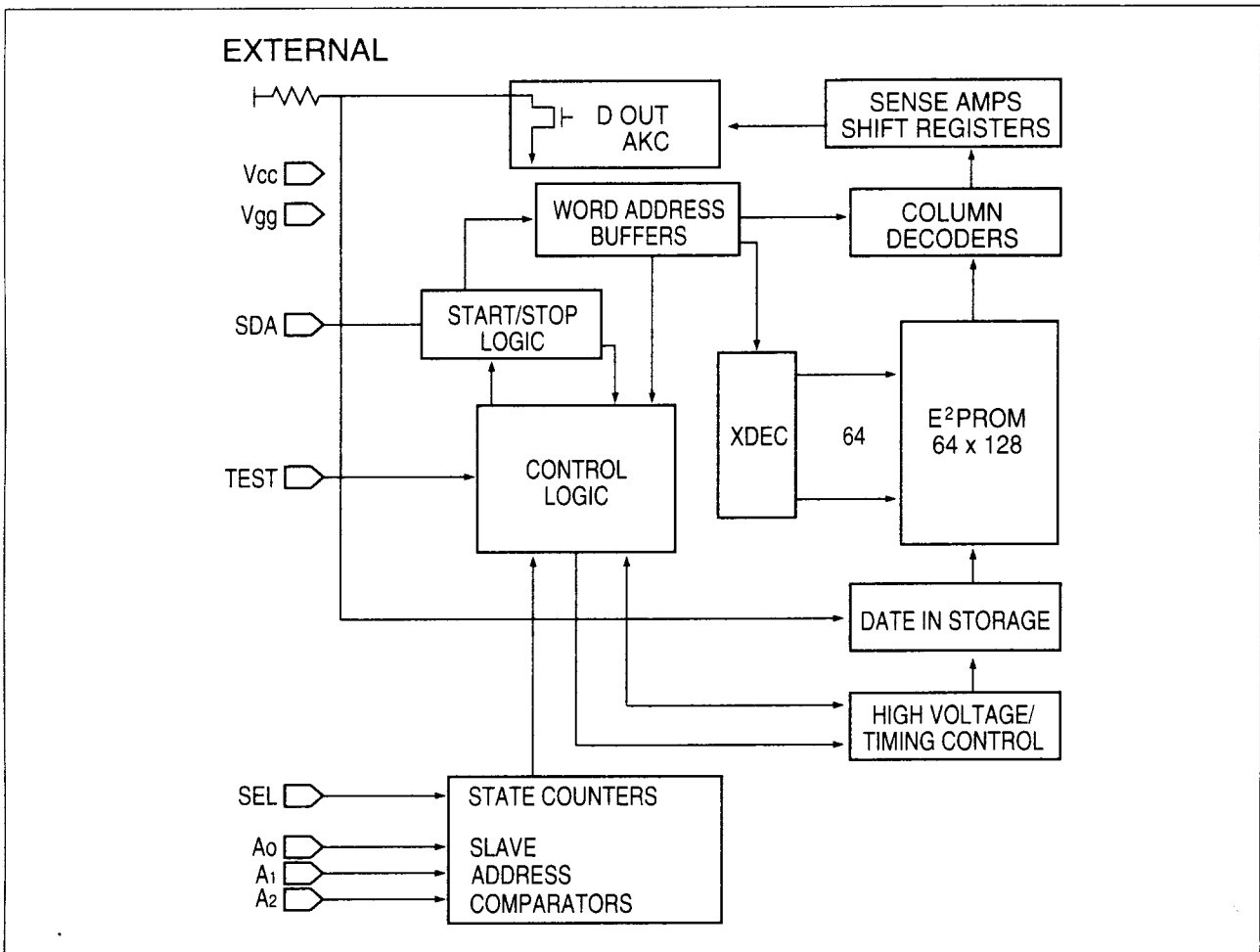

(4) Pin Description

PIN	SYMBOL	DESCRIPTION
1-3	A0, A1, A2	Device Address Inputs
4	Vss	Ground
5	SDA	Serial Data/Address
6	SCL	Serial Clock
7	TEST	Connect to Vss
8	Vcc	+5V Power supply

AN5515 (DBL2004) (TV Vertical Deflection Output Circuit)

(1) Features

- Low power consumption, direct deflection coil driving capability (Flyback voltage two times as high as supply voltage is supplied during flyback period only)

(2) Block Diagram

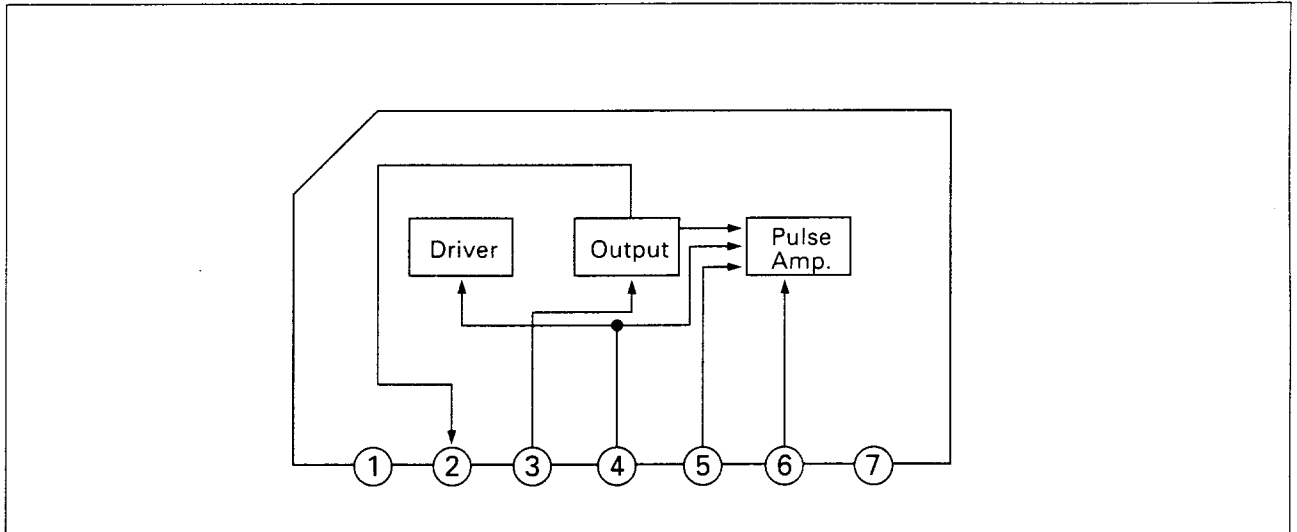

(3) Pin Description

PIN No.	Pin Name
1	GND
2	Output
3	Supply Voltage for Output
4	Input
5	Trigger Pulse Input
6	Pulse Amp. Output
7	Vcc

PCA84C122A (IC REMOCON)

(1) Features

- ROM, RAM and I/O is device dependent
- Two test inputs T0, T1
- 3 Single-level vectored interrupt sources
- 8 bit programmable timer/counter with 5-bit pre-scaler
- Single supply voltage from 2.0V to 5.5V
- On-board oscillator 1MHz to 5MHz
- Operating temperature range -20 to +50°C

(2) General Description

The PCA84C122AT is a stand-alone micro controller designed for use in remote control transmitters for a wide range of applications.

(3) Pin Description

PIN	SIGNAL	DESCRIPTION
3	P00	Standard I/O Port lines, generally used for keypad scanning
2	P01	
23	P02	
22	P03	
10	P04	
11	P05	
14	P06	
15	P07	
19	P10	Standard I/O Port lines, generally used for keypad scanning
18	P11	
17	P12	
16	P13	
1	P14	
24	P15	
12	P16	
13	P17	
4	TP/INT	Test T0 and external interrupt input
5	T1	Test T1
6	RESET	Active HIGH reset, normally tied to Vss because internal Power-on reset can serve the same function
8	XTAL 1	Crystal or ceramic resonator
9	XTAL 2	
21	OUT	Pulse train output pin, capable of sinking 27mA
7	VDD	Power supply
20	VSS	Ground

CF72306

(1) Features

- Forms a custom 2-chip solution when used with an ASIC TEXT decoder
- Low power 1um CMOS
- Standard 20 pin/300mH package
- Tolerates a range of video distortions
- Operates with 13.875MHz fundamental mode crystal

(2) Block Diagram

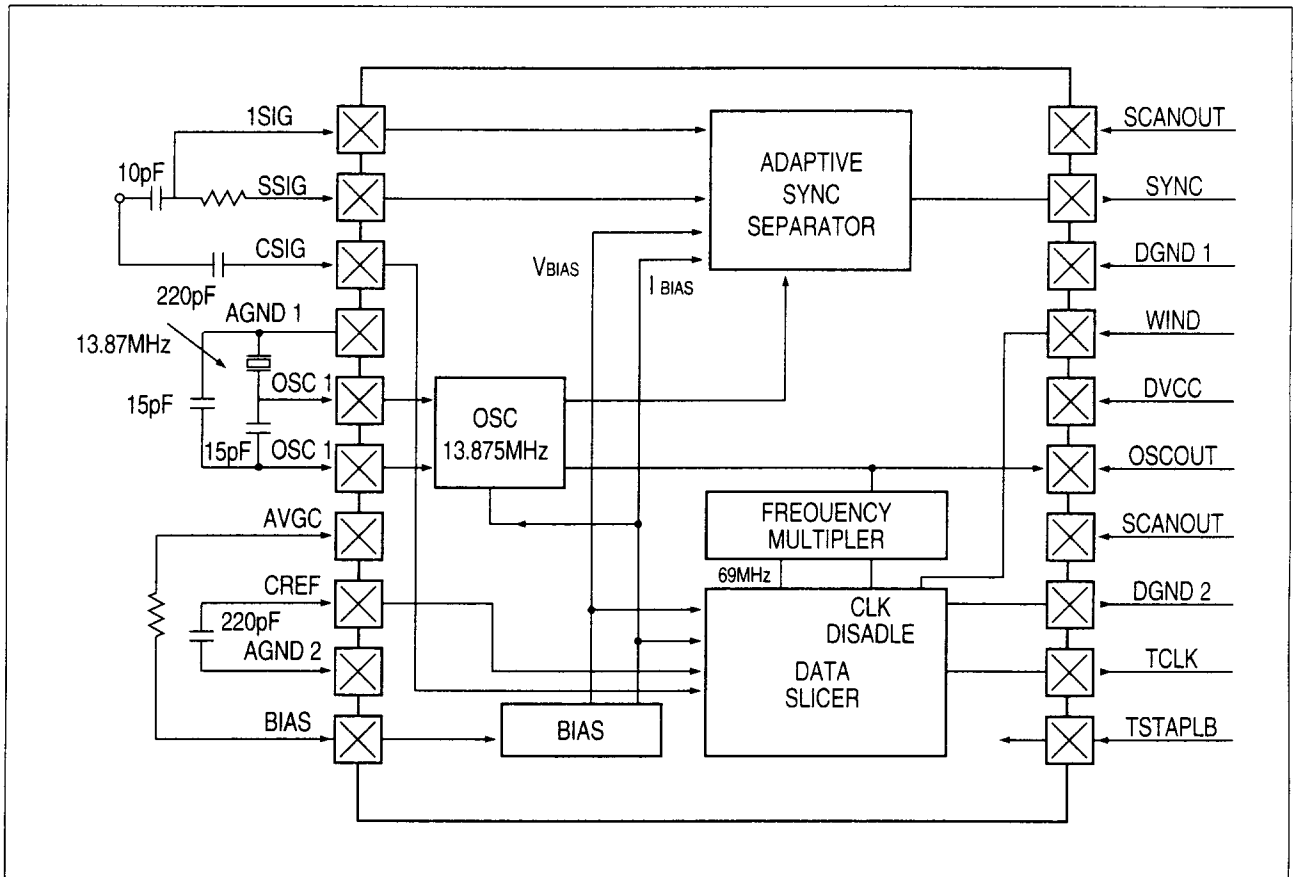

(3) Pin Description

PIN	SIGNAL	DESCRIPTION
1	TSIG	Video Sync Input 1
2	SSIG	Video Sync Input 2
3	CSIG	Video Data Input
4	AGND1	Analogue Ground
5	OSC1	13.875MHz Oscillator
6	OSC2	13.875MHz Oscillator
7	AVCC	Analogue Vcc
8	CREF	Video Data Reference Input
9	AGND2	Analogue Ground
10	BIAS	Internal Reference

PIN	SIGNAL	DESCRIPTION
11	TSTAPLB	Test/Application
12	TCLK	Teletext Clock
13	TDATA	Teletext Data
14	DGND2	Digital Ground
15	OSCOUT	Oscillator Output
16	DVCC	Digital Vcc
17	WIND	Timing Signal
18	DGND1	Digital Ground
19	SYNC	Separated Sync Output
20	SCANOUT	Test Scan Output

CF70200 (Teletext Decoders)

(1) Features

- Eight pages of one-chip Display RAM
- Europe-wide solution
- Automatic FLOF & TOP decoding
- Flicker-free packet 26 processing one chip
- Program delivery control
- Minimum software requirement
- Menu page capability
- Instantaneous page memory clear
- 75Ω RGB outputs
- Digital PLL
- Upgrade path from UNITEXT

(2) Block Diagram

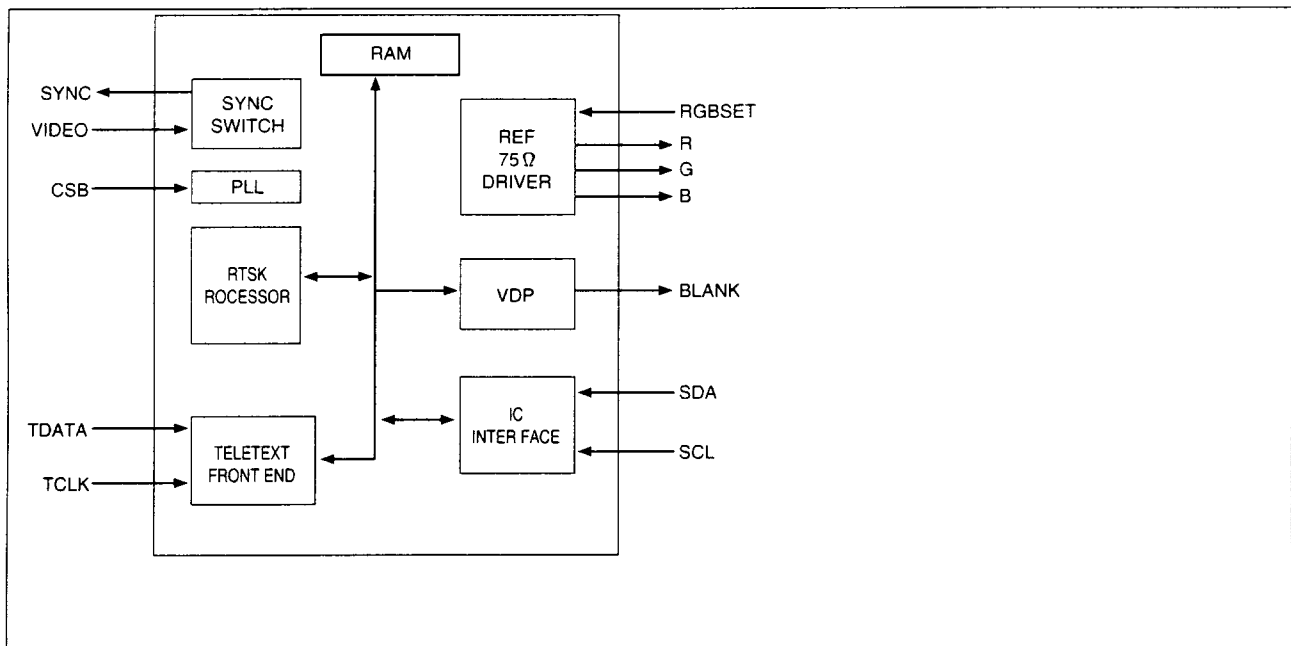

(3) Pin Description

pin	PIN NAME	DESCRIPTION
1	TEST 5	Test PIN
2	SYNC	The output of an internal sync switch
3	CVBS	Video input to sync switch
4	DVcc	+5V
5	RSTB	System reset active low
6	CLINK	System clock 13.875Mhz
7	DGND	Ground
8	T1	TEST PIN
9	T4	TEST PIN
10	TDATA	TELETEXT DATA
11	TCLK	TELETEXT CLOCK SIGNAL
12	CSB	COMPOSITE SYNC INPUT
13	MUTE	MUTE
14	T2	TEST PIN

PIN	PIN NAME	DESCRIPTION
15	WIND	WIND
16	T3	TEST PIN
17	SCL	IIC CLOCK LINE
18	SDA	IIC DATA LINE
19	BLK	BLANKING
20	B	DISPLAY DATA
21	AVCC	+5V
22	G	DISPLAY DATA
23	R	DISPLAY DATA
24	AGND	GROUND
25	RGBSET	Adjustment for the RGB, BLANK levels
26	REF	INTERNAL REFERENCE PIN
27	FLAG1	SYSTEM INFORMATION
28	FLAG2	SYSTEM INFORMATION

MSP 2410 (Multistandard sound processor)

(1) Features

- Two selectable analog inputs
- Automatic Gain control for analog input
- Integrated 6 bit A/D converter
- All demodulation and filtering is performed on chip and is individually programmable

(2) General Description

The MSP2410 Multistandard sound processor is a CMOS circuit, housed in a 44-pin PLCC package. It is the successor of the MSP2400.

(3) Block Diagram

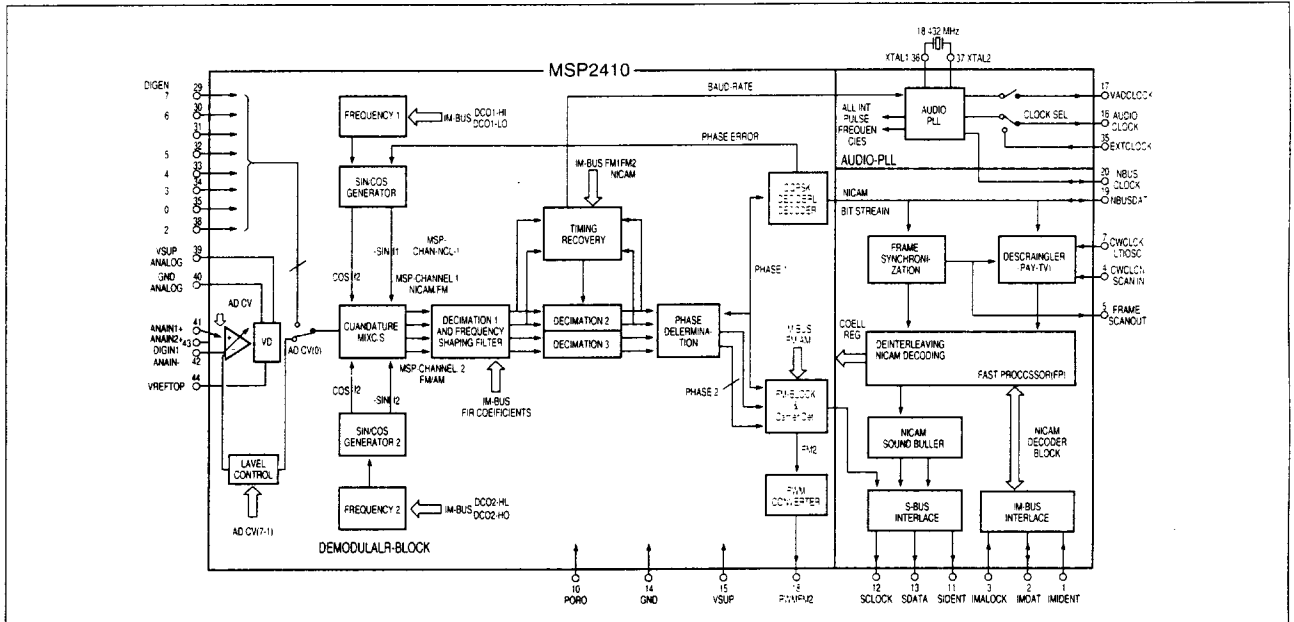

(4) PIN Description

PIN	PIN NAME	DESCRIPTION
1	VREF	A/D Converter
2	ANAIN2	Sound IF input from second audio source
3	ANAIN-	Common ground of sound-IF source 1 and 2
4	ANAIN+	Sound IF input from first audio source
5	AGND	Ground
6	AVCC	+5V
7	DICIN2	Digital Input
8	XTAL2	Crystal Output (18.432Mhz)
9	XTAL1	Crystal Output (18.432Mhz)
10	EXTCLOCK	Input for ext. clock
11	DIGIN3	Digital Input
12	DIGIN4	Digital Input
13	DIGIN5	Digital Input
14	DIGIN6	Digital Input
15	DIGIN 7	Digital Input
16	DIOUT6	Digital Output
17	DIOUT4	Digital Output
18	DIOUT4	Digital Output
19	DIOUT3	Digital Output
20	DIOUT2	Digital Output

PIN	PIN NAME	DESCRIPTION
21	DIOUT1	Digital Output
22	DIOUT0	Digital Output
23	NCLOCK	Clock for digital NACAM bit stream
24	NCDATA	NICAM Serial I/O
25	PWMFM	FM2 channel for FM-identification
26	VCLOCK	Clock for external A/D converter
27	ACLOCK	Main clock for AMU, APU, ADC or ACP
28	DVCC	Supply voltage
29	DGND	Ground
30	SDATA	S-BUS Data Out
31	SCLOCK	S-BUS IDENT
32	SIDENT	S-BUS IDENT
33	PORQ	Power on reset
34	RDSOUT	for test only
35	CWCLOCK	for test only
36	TESTIO	for test only
37	CWDATA	Pay-TV Data/TEst input
38	IMCLOCK	IM-BUS Clock
39	IMDATA	IM-BUS Data
40	IMIDENT	IM-BUS IDENT

ACP2371NI (Audio Processor for Multistandard TV sets)

(1) Features

- Dematrixing of the digital signals
- Adjustment of volume, balance, loudness, treble, bass, base width enlargement
- Independent input selection for speaker-out and scart-out.

(2) Description

The Audio processor ACP2371NI comprises two components-an A/D converter (ADC) and an Audio processor unit (APU) implemented in CMOS and NMOS technology.

(3) Block Diagram

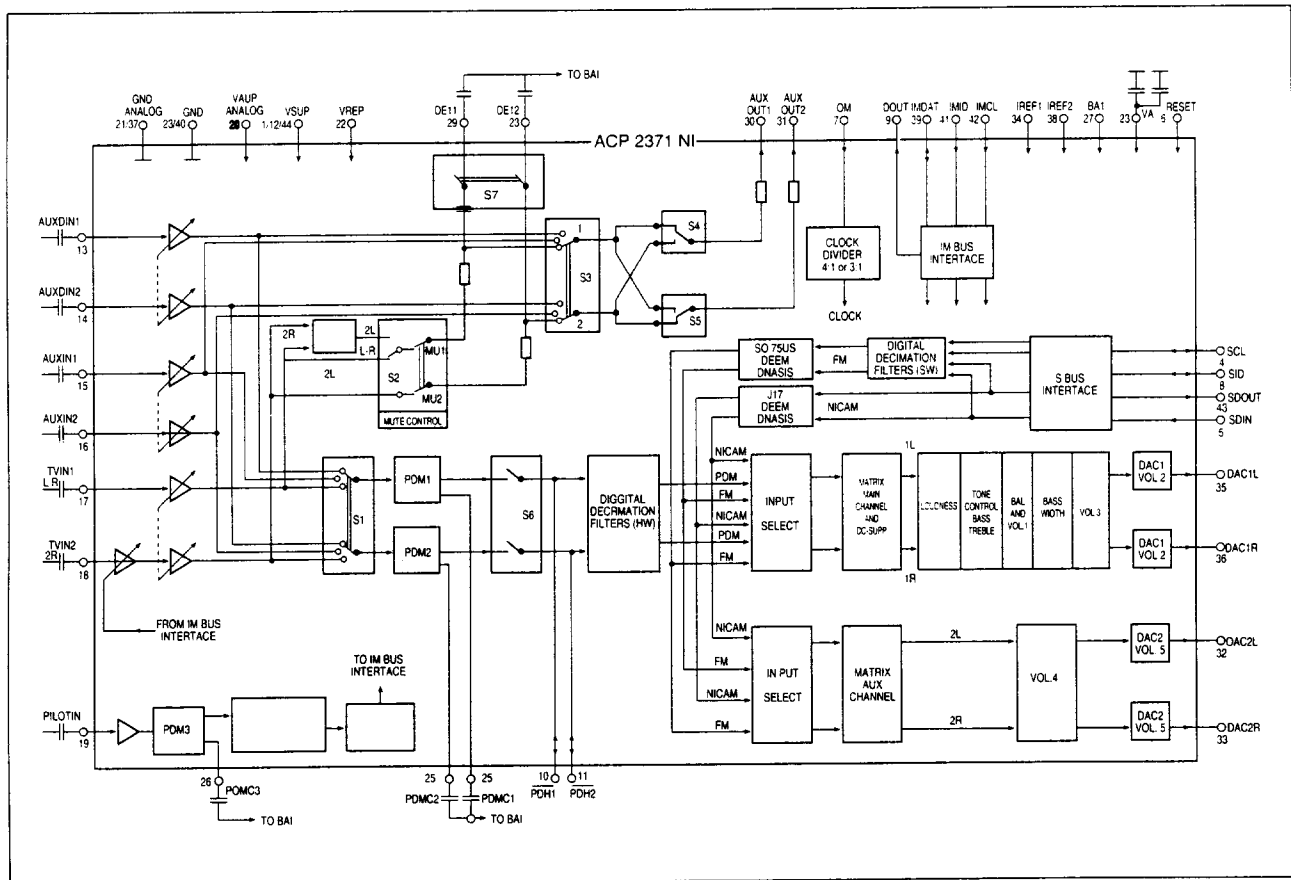

(4) Pin Description

PIN	SIGNAL	DESCRIPTION
1	VRETOP	A/D-Converter: Top Reference voltage
2	ANALOGIN 2+	Analog Input 2
3	ANALOGIN -	Common Ground of sound-IF sources 1 and 2
4	ANALOGIN +	Sound-IF input from first audio source
5	GNDANALOG	A/D-converter: Ground
6	VSUPANALOG	A/D-converter: Supply voltage (5V)
7	DIGIN 2	Connect to ground when using internal A/D-converter
8	XTAL 2	Crystal (18.432MHz)
9	XTAL 1	Crystal (18.432 MHz)
10	EXTCLOCK	Input for ext clock to be passed through the MSP2410
11	DIG IN 3	Connect to ground when using internal A/D-converter
12	DIG IN 4	Connect to ground when using internal A/D-converter
13	DIG IN 5	Connect to ground when using internal A/D-converter
14	DIG IN 6	Connect to ground when using internal A/D-converter
15	DIG IN 7	Digital Input MSB
16	DIG OUT 6	Digit output LSB
17	DIG OUT 5	Digit output LSB
18	DIG OUT 4	Digit output LSB
19	DIG OUT 3	Digit output LSB
20	DIG OUT 2	Digit output LSB
21	DIG OUT 1	Digit output LSB
22	DIG OUT 0	Digit output LSB
23	NBUS CLOCK	Clock of digital NICAM bit stream
24	NBUS DAT	NICAM 728 serial I/O
25	PWM FM ²	FM ² channel for FM-identification
26	VAD CLOCK	Clock for external A/D converter
27	AUDIO CLOCK	Main clock for AMU, APU, ADC or ACP
28	VSUP	Supply Voltage (digital)
29	GND	Ground (digital)
30	SDATA	S-BUS Data out
31	SCLOCK	S-BUS clock
32	SIDENT	S-BUS Ident
33	PORQ	Power on Reset
34	RDSOUT	For test only
35	CW CLK/LTIO SC	Pay-TV clock/Test Input
36	TEST IO	For test only
37	CW DATA/SCANIN	Pay-TV Data/Test input
38	IM CLOCK	IM-BUS CLOCK
39	IMDAT	IM-BUS Data
40	IMIDENT	IM-BUS Ident

TDA4445B (Quasi Parallel Sound Processor)

(1) Features

- Very high input sensitivity
- Excellent signal to noise ratio
- Fast averaged AGC
- IF amplifier can be switched off for VTR mode
- Output signal stabilized against supply voltage variations
- Very few external components
- Targeting bistandard applications
- Low AM distortion

(2) General Description

The TD4445B is quasi parallel sound processor with quadrature intercarrier demodulator.

(3) Block Diagram

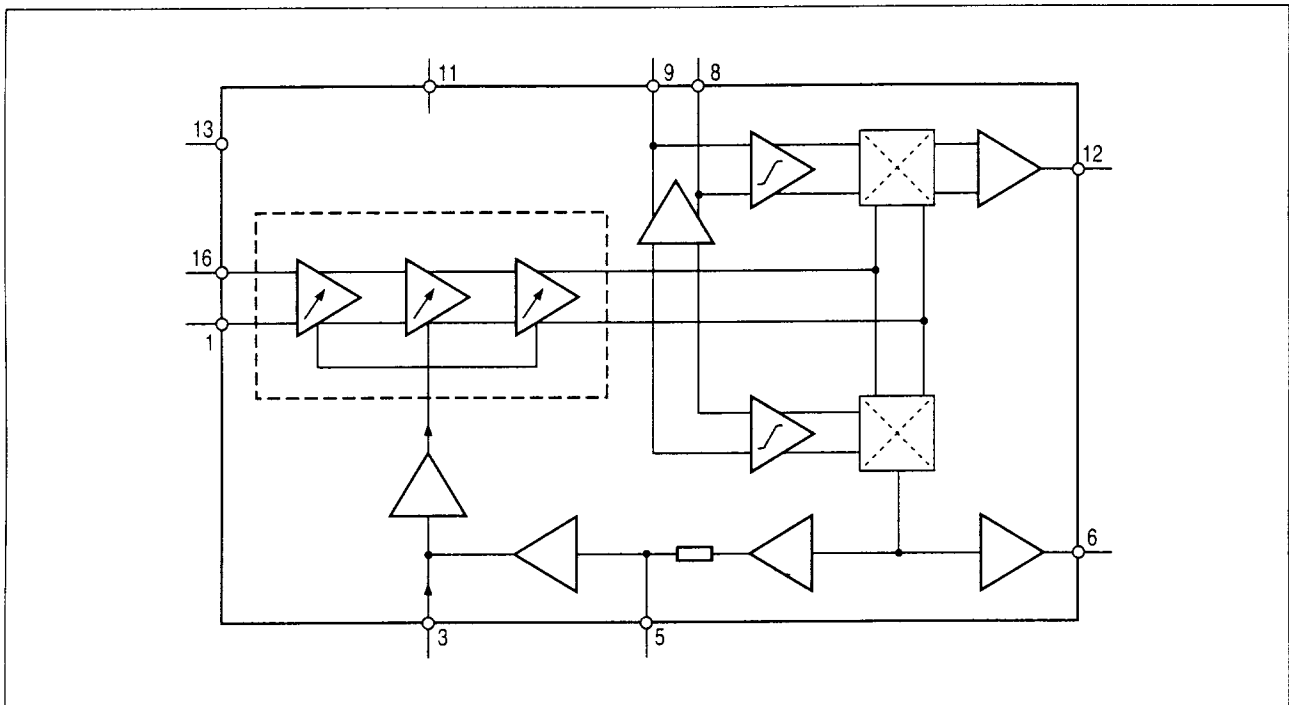

(4) Pin Description

PIN	DESCRIPTION
1,16	IF input
3	IF AGC time constant
8, 9	Tuned circuit
11	Supply voltage
12	Sound-IF-output
13	Ground
2,4,7,10 14,15	not be connected
5	Average capacitor
6	AF output

KA4558 (IC NICAM Low Pass Filter)

(1) Features

- No frequency compensation required.
- No latch-up
- Large common mode and differential voltage range.
- Parameter tracking over temperature range
- Gain and phase match between amplifiers
- Internally frequency compensated
- Low noise input transistors

(2) General Description

The KA4558 series is a monolithic integrated circuit designed for dual operational amplifier.

(3) Block Diagram

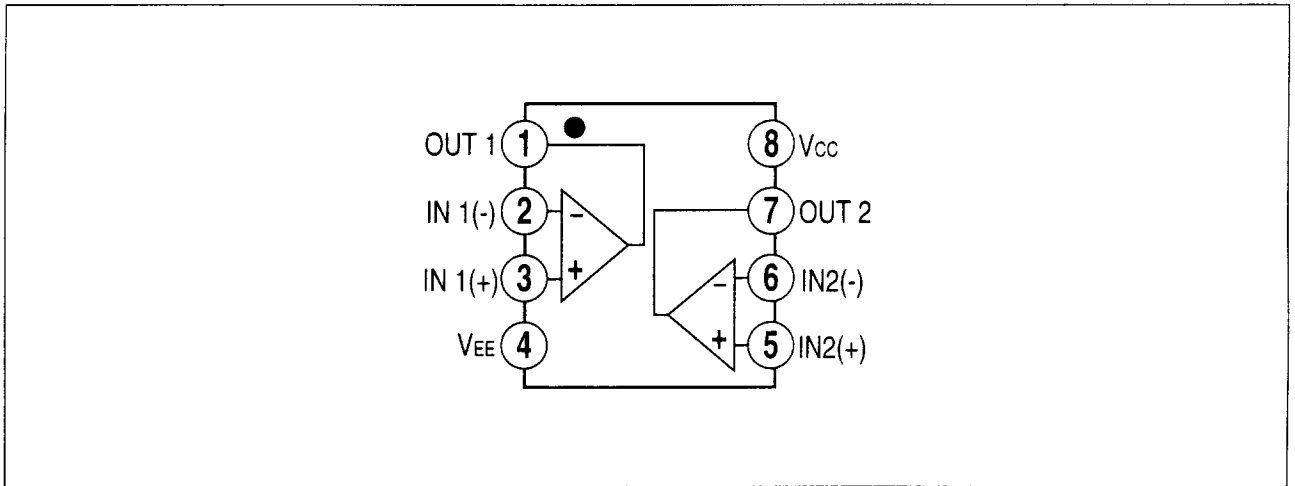

TDA3866 (Quasi-split Sound Processor for All Standards)

(1) Features

- Quasi-split sound processor for all standards e.g. B/G(FM sound) and L (AM sound)
- AF 2 signal automatically muted(at B/G) by the input signal level
- AM signal processing for L standard and switching over the audio signal
- Stereo-matrix correction
- Layout-compatible with TDA3858 and TDA3857
- AM output level typically 500mV at $m=0.54$

(2) General Description

Separate symmetrical IF inputs for FM or AM sound. Gain controlled wideband IF amplifier, input select switch. AGC generation due to peak sync for FM or mean signal level for AM. Reference amplifier for the regeneration of the vision carrier.

(3) Block Diagram

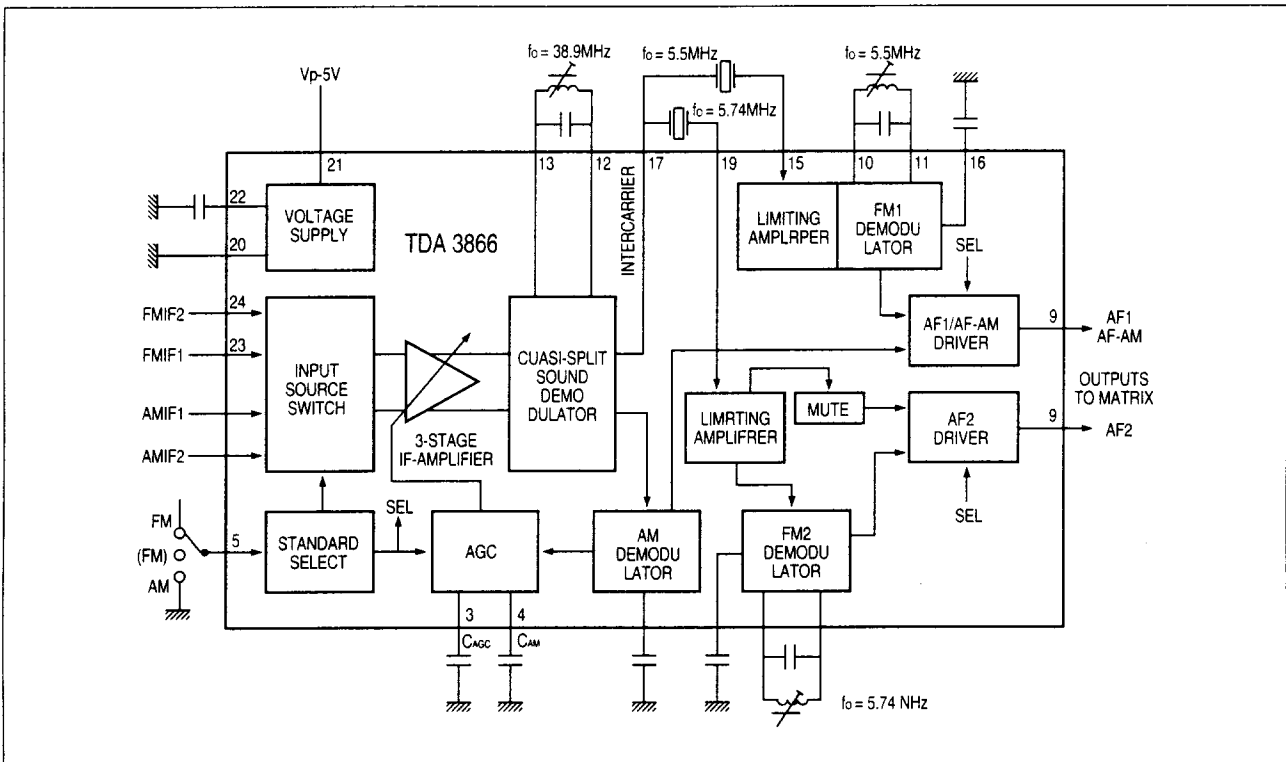

(4) Pin Description

PIN	SYMBOL	DESCRIPTION
1	AMIF 1	AM IF difference input 1 for L standard (32.4 MHz)
2	AMIF 2	AM IF difference input 2 for L standard
3	C _{AGC}	charge capacitor for AGC (FM and AM)
4	C _{AM}	charge capacitor for AM AGC
5	MODE	3-state input for standard select
6	FM2R1	reference circuit for FM2 (5.74 MHz)
7	FM2R2	reference circuit for FM2 (5.74 MHz)
8	AF2	AF2 output (AF out of 5.74 MHz)
9	AF1	AF1 output (AF out of 5.5 MHz or AM)
10	FM1R1	reference circuit for FM1 (5.5 MHz)
11	FM1R2	reference circuit for FM1 (5.5 MHz)
12	VC-R1	reference circuit for the vision carrier (38.9 MHz)
13	VC-R2	reference circuit for the vision carrier (38.9 MHz)
14	C _{AFAM}	DC-decoupling capacitor for AM demodulator (AF-AM)
15	FM11	intercarrier input for FM1 (5.5 MHz)
16	C _{AF1}	DC-decoupling capacitor for FM1 demodulator (AF1)
17	ICO	intercarrier output signal (5.5/5.74 MHz)
18	C _{AF2}	DC-decoupling capacitor for FM2 demodulator (AF2)
19	FM21	intercarrier input for FM2 (5.74 MHz)
20	GND	ground (0V)
21	V _p	+5 ... +8V supply voltage
22	C _{ref}	charge capacitor for reference voltage
23	FMIF1	IF difference input 1 for B/G standard (38.9 MHz)
24	FMIF2	IF difference input 2 for B/G standard (38.9 MHz)

TDA6612-5 (IC Audio Processor)

(1) Features

- All functions inclusive matrix adjustment are I²C bus controlled
- Inputs for AM sound or NICAM
- SCART interface
- Independent headphones
- Universal clock generation circuit build-in
- Clipping detector build-in
- Volume control
- High signal to noise ratio
- Extremely low total harmonic distortions

(2) General Description

The TDA6612-5 represents a complete TV stereo system controlled by the I²C bus according to German TV stereo standard.

(3) Block Diagram

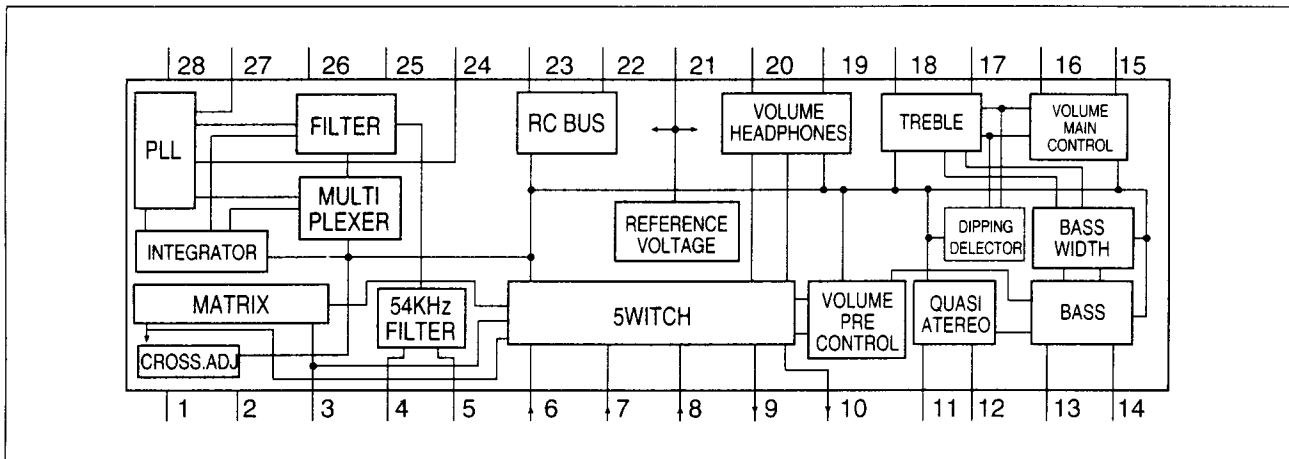

(4) Pin Description

PIN	DESCRIPTION
1	AF input mono, left, sound 1 (may be balanced)
2	Bias for AF operating point
3	AF input right, sound 2
4	54 kHz input
5	54 kHz filter
6	AF input (L standard)
7	AF input SCART left (sound 1)
8	AF input SCART right (sound 2)
9	AF output SCART (mono, sound 1, left)
10	AF output SCART (mono, sound 2, right)
11	Phase shifter quasistereo
12	Phase shifter quasistereo
13	Cutoff frequency bass (base width) left
14	Cutoff frequency bass (base width) right

PIN	DESCRIPTION
15	AF output, loudspeaker right
16	AF output, loudspeaker left
17	Cutoff frequency treble left
18	Cutoff frequency treble right
19	AF output, headphones right
20	AF output, headphones left
21	+Vs (supply voltage)
22	I ² C bus SCL
23	I ² C bus SDA
24	Input H pulse (4•H pulse), crystal oscillator
25	Filter ID signal decoder
26	Filter ID signal decoder
27	PLL filter ID signal decoder
28	Ground

TDA 4601

(1) Features

- Direct control of the switching transistor
- Low start-up current
- Reversing linear overload characteristic
- Base current drive proportional to collector current.
- Protective circuit in case of disturbance.

(2) General Description

The integrated circuit TDA 4601 is designed for driving, controlling and protecting the switching transistor in self-oscillation flyback converter power supplies as well as for protecting the overall power supply unit.

(3) Block Diagram

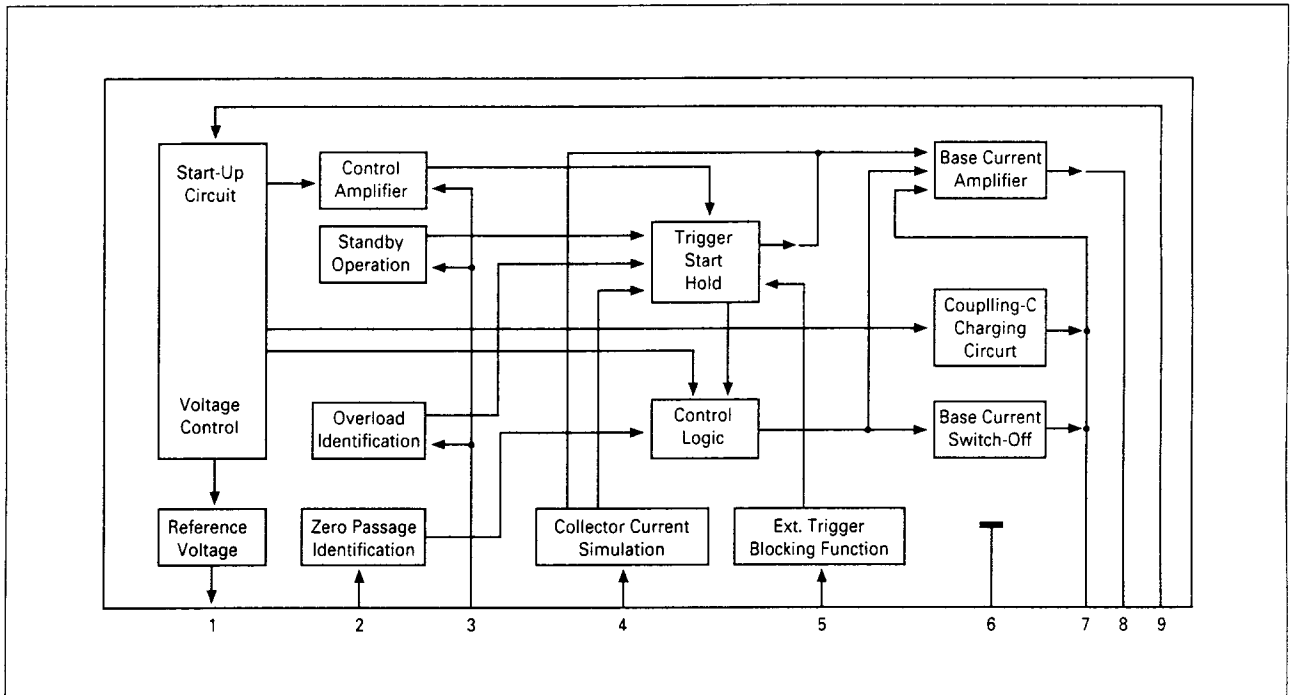

(4) Pin Description

PIN	DESCRIPTION
1	VREF output
2	Zero passage identification
3	Input control amplifier, overload amplifier
4	Collector current simulation
5	Connection for additional protective circuit
6	Ground (rigidly connected to substrate mounting plate)
7	DC output for charging coupling capacitor
8	Pulse output-driving of switching transistor
9	Supply voltage

■ CP-365 CIRCUIT DESCRIPTION

The function of the circuits used in CP-365 are described in this chapter. The component numbers, used in this description, refer to the circuit diagram.

1. Small signal part with TDA8362

TDA8362 is realized in BIMOS process; the high frequency bipolar process is used for video processing and the MOS process is used for the digital part.

TDA8362 combines all small signal functions, except the tuning, required for a colour television receiver.

Newly developed internal circuitry, such as integrated luminance delay line, chroma bandpass and trap, PLL sound demodulator and switches, reduce the number of required pins, external components and alignments.

The reference tuned circuit is the only remaining alignment for this 52 pins (S-Dil) TV-processor!

The alignment-free SECAM add-on colour decoder circuit (TDA8395) can be used for applications with automatic standard switching.

The internal functions of TDA8362 are

- Completely symmetrical AC-coupled vision I.F. amplifier and synchronous video demodulator
- A.G.C. detector suited for positive and negative modulation
- Tuner A.G.C., for PNP tuners
- Sample and hold A.F.C. circuit, with internal 90° phase shift
- Video pre-amplifier
- Inputs and switches for external audio, CVBS and S-VHS signals
- Sound I.F. limiter, automatic PLL demodulator and pre-amplifier with DC volume control.
- Separate supply pin to start the horizontal circuitry from the mains rectifier
- Horizontal synchronization circuit with 2 control loops
- Vertical synchronization (divider system), automatic 50/60Hz adaption
- Vertical and horizontal drive circuits
- PAL/NTSC colour decoder, with automatic standard switching
- Chroma filters (bandpass and trap) with automatic system adaption
- Luminance delay line
- Peaking circuit is the luminance channel
- Mute function
- X-ray protection possibility.

1.1. Vision I.F. amplifier, video demodulator and identification circuit.

- The vision I.F. amplifier consists of three AC-coupled differential stages.

The gain control per stage is more than 20dB, which results in a total gain control of 64dB min. The amplifier is completely symmetrical, which has the advantage of a less critical application; the I.F. amplifier inputs can be coupled directly to the SAW-filter output.

The input impedance is 2k Ω in parallel with 3pF.

The input sensitivity for on-set of A.G.C. is 70 μ V (typ.), for I.F. frequencies between 38.9MHz and 58.75MHz.

- The reference carrier for the video demodulator is obtained via passive regeneration of the picture carrier. The reference tuned circuit is connected between pin 2 and 3.

The IC can handle positive and negative modulated signals, the polarity of the demodulation can be switched at pin 1 (open = neg. modulation, high = pos modulation).

- A transmitter identification circuit operates independently of the synchronization circuit, to allow separate use of the front-end section and the display section of the TDA8362.

1.2. A.G.C., tuner A.G.C. and A.F.C.

- The A.G.C. detector operates at top-sync level for signals with negative modulation and at peak-white level for positive modulated signals.

This A.G.C. detector is gated for negative modulated signals to reduce sensitivity to impulsive noise.

The time constant capacitor (C109) is connected externally at pin 48.

- The tuner AGC take-over point can be set by adjusting the DC-voltage at pin 49, with a potentiometer of 10k Ω (VR101).

The tuner A.G.C. (pin 47) is an open collector output stage with an output swing of 2mA min. the voltage swing, required by the tuner, can be obtained with an external resistor network, connected at pin 47. Pin 47 may rise 2V above the actual supply voltage level for min. gain.

- The A.F.C. circuit is driven by the same reference signal as the video demodulator. A sample and hold circuit avoids video bread-through from the video demodulator to the A.F.C. voltage.

The A.F.C. output voltage range is from 0 to 8V.

1.3. Horizontal and vertical synchronization

- The incoming video signal, pin 15 for the video signal is fed to the synchronization separator circuit. Internally the black level and the top sync level are detected, next the synchronization pulses are amplified to a fixed level and sliced at 50% of that level. In this way a very good synchronization performance is obtained. The separated synchronization pulses are fed to the first phase detector circuit and to the coincidence detector. The components which determine the loop gain of the first phase detector are connected at pin 40 (C401, CC401 and RC401). The coincidence detector is only used to detect whether the line oscillator is synchronized, not for transmitter identification. The line oscillator is running at twice the line frequency and locked to the X-tal controlled oscillator frequency of the colour decoder, consequently no adjustment is required. The free-running frequency has a maximum deviation of 2% compared to the nominal frequency. The second phase detector generates the pulses for the horizontal driver stage (pin 37). The loop filter capacitor (C511) is connected at pin 39. Horizontal shift can be obtained by a potentiometer and series resistor (VR401) connected at pin 39. The TDA8362 has a separate start-up circuit for the horizontal oscillator (pin 36). In case this feature is used for starting the horizontal deflection the resistor connected at the base of the horizontal driver transistor must be connected to the start supply as well (pin 37 is an open collector). For applications which do not require a start-up function pin 36 must be connected to the main supply voltage (pin 10).
- The vertical drive pulses (pin 43) are generated by a divider circuit. The vertical ramp generator components are connected at pin 42. Capacitor C308 is charged via resistors (R311, VR302, R308) connected to +33V AC and DC feedback voltage from the vertical deflection stage must be connected at pin 41.

1.4. Integrated video filters

- The TDA8362 has an alignment-free internal chroma bandpass and trap circuit. These filters are realized by means of gyrator circuits and they are tuned by tracking to the frequency of the X-tal controlled oscillator.
- The luminance delay and the delay required for peaking are also realized by gyrator circuits. The peaking circuit can be controlled by μ -processor output voltage.

1.5. Colour decoder.

- The colour decoder contains an alignment-free X-tal oscillator, a killer circuit and the colour difference signals demodulators. The decoder adapts automatically for PAL and NTSC signals. With the SECAM add-on decoder TDA8395 an alignment free multi-standard decoder with automatic selection can be built. This makes the application of the TDA8362 very flexible. The following applications are possible:
 - PAL-only
Connect one or two crystals to the IC (when just one crystal is used the other crystal pin has to be connected to ground via a resistor) and the hue control pin to the positive supply via a resistor of about 30 k Ω . In this condition the decoder will not search for NTSC signals.
 - PAL/NTSC
Connect one or two crystals to the IC and supply a control voltage between 0 and 5 V to the hue control pin. The decoder will identify PAL and NTSC signals at one or two frequencies. For the reception of the PAL-N and the PAL-M standard the two 3.6 MHz X-tals must be connected to pin 34. The switching between the X-tals must be made externally.
 - PAL/SECAM
The chroma input signal for the SECAM decoder must be the same as that of the PAL decoder. This could be realized by means of an external switch which is connected in parallel with the internal video switch. In the TDA8362 we have a better alternative. When the NTSC option is not required the output signal of the switch can be obtained from the hue control input when this input is connected to the positive supply line via a suitable resistor.
 - PAL/SECAM/NTSC
In this case the hue control must be active so that the previous application is not possible. Therefore an external video switch has to be added for this application. In CP-365, the first three applications are possible, but in PAL/NTSC application NTSC-M is available in external video only. The burst phase detector locks the X-tal oscillator with the burst signal. Two gain modes provide an increased catching range when the PLL is un-locked and low ripple voltage and good noise immunity when the PLL is locked. The burst phase detector operates during the burst key period only, to prevent the PLL from being disturbed by the chroma signal. The killer circuit switches-off the R-Y and B-Y demodulators at too low input signal condition (burst amplitude). Proper hysteresis prevent constant on/off switching at a certain input level.

1.7. R.G.B output and input circuits

The colour difference signals are matrixed with the luminance signal to obtain the R,G,B output signals (pin 18, 19 and 20). Linear amplifiers have been chosen to interface external R,G,B signals (pin 22, 23 and 24) coming from the Peritelevision connector. The contrast and brightness control operate both on internal and external signals. The data insertion pin 21 has a second detection level at 4V. Above this level the R,G,B outputs are blanked. In this way on-screen display (O.S.D.) signals can be supplied directly to the inputs of the video output stages without any interaction to the RGB outputs of the colour decoder part of the TDA8362.

2. Tuner

The board of CP-365 is designed to use the tuner type VTSS-7SZ3(PAL/SECAM-B/G, D/K'), TEKE4-073A(HYPER BAND), DET7BZ(PAL-I).

These have combined VHF/UHF (DET7BZ is UHF only), electronic tuning and band switching.

They can be used in applications with voltage synthesis tuning system.

The tuners fulfill all requirements concerning radiation, signal handling capacity and immunity for radiated interferences.

	BAND	STANDARD	PIF
VTSS-7SZ3	VHF UHF	B/G, D/K	38.9M
TEKE-073A	VHF UHF	B/G	38.9M
DET7BZ	UHF	I	39.5M

3. SECAM decoder TDA8395

The TDA8395 is an alignment-free SECAM colour decoder and can be used in conjunction with the TDA8362. It includes the Cloche filter, demodulator and identification circuit. The TDA8395 application needs very few external components.

The cloche filter is a gyrator-capacitor type filter. Its resonance frequency is controlled during the calibration period and offset during scan for the right resonance frequency. The required reference frequency for calibration must be connected at pin 1 and obtained from the TDA8362 (pin 32). The two (or three-) level sandcastle pulse has to be connected at pin 15(TDA8362 pin 38) and used for generation of the blanking periods and provides clock information for the identification circuit.

The chroma signal at pin 16 connected to pin 27 of the TDA8362 is demodulated by a PLL demodulator, which uses the reference frequency and a bandgap reference to force the PLL to the desired demodulation characteristic. Digital line identification is implemented to check the incoming signal for SECAM. IF SECAM is detected and pin 1 will sink a current of 150 μ A. Together with the TDA8362 the voltage at this pin will become high (5.5V). In this case the colour difference signal outputs will be switched on. These outputs will be disconnected and high-ohmic when no SECAM is detected for two frame periods the demodulator will be initialized before trying again.

4. Baseband delay line TDA4661

TDA4661 are integrated baseband delay lines of 64 μ S for colour television receivers. It can be connected to the TDA8362 and TDA8395 without the need of switches and alignments. The TDA4661 consists of two main blocks.

- Two comb filters with a delay time of 64 μ sec in switched capacitor
- Internal clock generation of 3MHz, line locked via the sandcastle pulse

The TDA4661 operates according to the mode demanded by the colour transmission standard. In PAL mode it operates as a geometric adder to satisfy the requirements of PAL demodulation, in NTSC mode it reduces cross-colour interference (comb-filtering) and in SECAM mode the delay line repeats the colour difference signal on consecutive horizontal scan lines.

The colour difference signals are AC-coupled to pin 14 and 16 and clamped by the input stages. The internal clock drives the delay lines to obtain the required 64 μ sec. The clock pulses are derived from a 6MHz Current Controlled Oscillator which is line locked via a PLL with the sandcastle pulse, connected at pin 5. Sample and hold low pass filters suppress the clock signal. The delayed and un-delayed signal are added buffered and fed to the output pins 11 and 12.

5. SOUND OUTPUT STATE TDA 7263M

TDA7263M is class AB dual audio power amplifier assembled in the multiwatt package specially designed for high quality sound application stereo TV sets.

TDA7263M has the AC short circuit protection and thermal overload protection.

TDA7263M delivers an output power of 2W into a loud-speaker load of 8Ω with 28V supply voltage without the need of an external heatsink.

The gain is internally fixed at 60dB.

L, R outputs at pins 1,2 of sound board make inputs at pins 1,5 of TDA7263M, and they are amplified.

The pins 8,10 which are sound outputs of TDA7263M generate amplified sound, and a sound comes out of loud-speaker via C610, C611.

6. Vertical output stage with AN5515 (DBL2004)

AN5515 (DBL2004) is a vertical deflection output circuit for drive of various deflection systems with currents up to 1.48APP.

Pin 43 of TDA8362 is connected to pin 4, the input for the driver of the output stage via R309.

Capacitors C301, C302 are for decoupling.

During scan the capacitor between pin 3 and 6(C304) is charged. When the flyback starts and the voltage at the output pin 2 exceeds the supply voltage at pin 7, the flyback generator is activated. The supply voltage is then connected in series, via pin 6, with the voltage across capacitor C304 during the flyback period. This implies that the supply voltage can be reduced to the required scan voltage plus the saturation voltage of the transistors.

The vertical synchronization information required by a μ -processor, available at pin 6 is obtained via R301, D301.

7. Horizontal Deflection stage

The horizontal drive pulses, pin 37 of TDA8362, are connected to the base of driver transistor Q401 via resistor R454.

The base current of the driver transistor is supplied via RC405 (pin 37 is an open collector output).

The driver transformer (T402) drives deflection transistor Q403.

T402 is EHT transformer (Flyback transformer) and generates the EHT -, focus- and G2-voltage, required by the picture tube. Furthermore the +185V supply and heater voltage are derived from this transformer.

At pin 7 the beam current information is measured via resistor R409. This information is used for reducing the contrast at too high beam currents (via D708).

The flyback voltage is clipped between +8V and ground by diodes D407, D468 to obtain a well shaped flyback pulse for feedback to the TDA8362 (pin 38).

A horizontal synchronization information required by a possible μ -processor is obtained via R416 & D406 connected at pin 3 of the FBT.

8. POWER SUPPLY WITH TDA4601

TDA4601 is designed for driving, controlling, and protecting the switching transistor in flyback converter power supplies during start-up, normal, and overload operation as well as during disturbed operation.

TDA4601 drives as start voltage(13V_{DC}) being supplied at pin 9 of TDA4601.

Continually, voltage(180V_{AC} \rightarrow 13V_{DC}, 270V_{AC} \rightarrow 15V_{DC}) is supplied at pin 6 of SMPS transformer(TSM-4402).

The function of power ON/OFF is activated by using switching transistor Q801(2SD1555).

The pin 1 of TDA 4601 is REFERENCE VOLTAGE PIN, pin 2 is AIR GAP PORT, pin 3 is the ADJUSTMENT PORT of secondary B+ level, pin 4 is AMP CONTROL PORT, pin 7 is the ELECTRIC DISCHARGE PORT of switching transistor, and pin 8 is OUTPUT VOLTAGE to drive switching transistor.

The voltage of secondary main B+ adjusts to 104V_{DC} to make use of variable Volume(VR801) at picture control maximum.

The protective operating mode of TDA4601 is that the base current shut-down activated by the control logic clamps the output of pin 7 to 1.6V_{DC}.

As a result, the drive of switching transistor is inhibited.

This protective measure is enabled if the supply voltage at pin 9 reaches a value 6.7V.

TDA4601 has self-protective function.

■ IC/TR DC VOLTAGE CHARTS

- * Input signal PAL/CH5-Video : 8 step colour bar (87.5% AM)
Audio : 1KHz sinewave (60% FM)
- * User's control condition Contrast, Brightness, Colour, Volume Controls-max.
- * Line voltage AC 230V, 50Hz
- * All the voltage in each point are measured with Mutimeter.

■ IC

1. I702 (TDA8362)

Pin No.	1	2	3	4	5	6	7	8	9	10
V (DC)	3	5.9	5.9	0	0	0	3.2	1.9	0	8

Pin No.	11	12	13	14	15	16	17	18	19	20
V (DC)	0	3.5	0	4.7	4	8	3	1.5	1.5	1.9

Pin No.	21	22	23	24	25	26	27	28	29	30
V (DC)	0.3	4	4	4	2.2	4.3	5.7	3.9	3.9	1.5

Pin No.	31	32	33	34	35	36	37	38	39	40
V (DC)	1.5	1.7	4.7	2.9	2.1	8.2	0.4	0.5	2.7	3.8

Pin No.	41	42	43	44	45	46	47	48	49	50
V (DC)	2.2	2.9	2.6	3.8	4	4	3.2	4.3	1.5	3.7

Pin No.	51	52
V (DC)	4.6	6.6

2. I701 (TMS73C167)

Pin No.	1	2	3	4	5	6	7	8	9	10
V (DC)	4	0	4	4	4	4.4	1.3	0	0	0

Pin No.	11	12	13	14	15	16	17	18	19	20
V (DC)	11	11	0	0	0	0	0	0	2.8	0

Pin No.	21	22	23	24	25	26	27	28	29	30
V (DC)	5	5	5	5	5	5	0	5	5	5

Pin No.	31	32	33	34	35	36	37	38	39	40
V (DC)	5	0	0	0	0	0	5	5	5	0

Pin No.	41	42	43	44	45	46	47	48	49	50
V (DC)	5	0	1.9	2.5	5	0	5	5	5	5

Pin No.	51	52	53	54
V (DC)	5	5	0	5

3. I502 (TDA4661)

Pin No.	1	2	3	4	5	6	7	8	9	10
V (DC)	5.6	0	0	0	0.5	0	0	0	5.6	0

Pin No.	11	12	13	14	15	16
V (DC)	3.3	3.3	0	1.5	0	1.5

4. I503 (TDA8395)

Pin No.	1	2	3	4	5	6	7	8	9	10
V (DC)	1.7	1.2	8.2	0	0	0	3	4.2	1.5	1.5

Pin No.	11	12	13	14	15	16
V (DC)	0	0	0	0	0.5	5.7

5. I504 (LA7950)

Pin No.	1	2	3	4	5	6	7	8	9	10
V (DC)	5	11.8	11	11.2	0	0	0	0	0	0

6. I601 (TDA7263M)

Pin No.	1	2	3	4	5	6	7	8	9	10	11
V (DC)	1.5	1.5	12	1.5	1.5	0	0	10.8	22	10.8	0

7. I301 (AN5515)

Pin No.	1	2	3	4	5	6	7
V (DC)	0	11.7	27	1.4	0	0.9	27

8. I801 (TDA4601)

Pin No.	1	2	3	4	5	6	7	8	9
V (DC)	4	0	2	2.3	7	0	2	1.9	13

9. I701 (SN76861)

Pin No.	1	2	3	4	5	6	7	8	9	10
V (DC)	6.3	2.3	6.3	1.9	6.3	6.3	6.3	0	5.3	1.9

Pin No.	11	12	13	14	15	16	17	18	19	20
V (DC)	6.3	1.9	6.3	3	5.3	1.9	1.3	1.9	6.3	3.0

Pin No.	21	22	23	24	25	26	27	28	29	30
V (DC)	5.3	6.3	1.9	6.3	0	5	5	0	0	3.8

Pin No.	31	32	33	34	35	36	37	38	39	40
V (DC)	0	0	5.8	0	5.8	5.8	6.2	2.5	11.8	3.2

10. I901 (CF72306)

Pin No.	1	2	3	4	5	6	7	8	9	10
V (DC)	0.9	1.2	1.3	0	2	3	5	1.1	0	1.7

Pin No.	11	12	13	14	15	16	17	18	19	20
V (DC)	0	0	0	0	2.6	5	3.5	0	0	0

11. I902 (CF70200)

Pin No.	1	2	3	4	5	6	7	8	9	10
V (DC)	5	1.5	1.5	5	5	2.6	0	0	0	0

Pin No.	11	12	13	14	15	16	17	18	19	20
V (DC)	0	0	0	0	3.5	5	5	5	0	0

Pin No.	21	22	23	24	25	26	27	28
V (DC)	5	0	0	0	1.4	1.4	0	5

TR

1. Main Board

Loc. No.		Q101	Q102	Q113	Q116	Q117	Q118	Q202	Q203	Q204	Q205
V (DC)	E	3.3	1	0.8	0	11.8	11.7	0	0	0	2
	C	7.7	8.9	4.9	0.5	0	0	0	7.7	3.7	7.4
	B	0	1.7	1.4	0	11.8	11.7	0	0	0	2.6

Loc. No.		Q210	Q211	Q212	Q221	Q250	Q401	Q402	Q601	Q610	Q701
V (DC)	E	11.6	11.6	11.6	0	0	0	0	1.8	0	0
	C	0	11	0	4.7	6.3	2	36	11.6	13	6.5
	B	11	11.6	11	0	0	0	0.5	2	0	1.4

Loc. No.		Q702	Q703	Q704	Q705	Q706	Q707	Q709	Q710	Q711	Q712	Q803	Q804	Q805	Q806
V (DC)	E	0	0	0	1	0	0	7.8	0	3.1	0	0	0	12	0
	C	1.4	5	0	0	4.7	4	7.8	0	11.3	0	0.6	0.6	12	13
	B	1.4	0	5	5	0	0	7.2	0.6	3.7	5	0	0	0	0

2. CRT Board

Loc. No.		Q501	Q511	Q521	Q502	Q512	Q522
V (DC)	E	2	2	2	2.9	2.9	2.9
	C	145	145	145	0	0	0
	B	2.6	2.6	2.6	2.2	2.2	2.2

3. NICAM Board

Loc. No.		QA01	QA02	QA03	QA04	QA06	QA07
V (DC)	E	6.6	0	0	6.7	6.7	0
	C	12	0	0	12	12	6.1
	B	7.3	0.7	0	0	7.3	

4. 2-Carrier Board

Loc. No.		QS01	QS02	QS03
V (DC)	E	0	0	0
	C	0.1	2.6	4.8
	B	0.6	0	0

PRINTED CIRCUIT BOARDS

■ Solder Side

• MAIN PCB

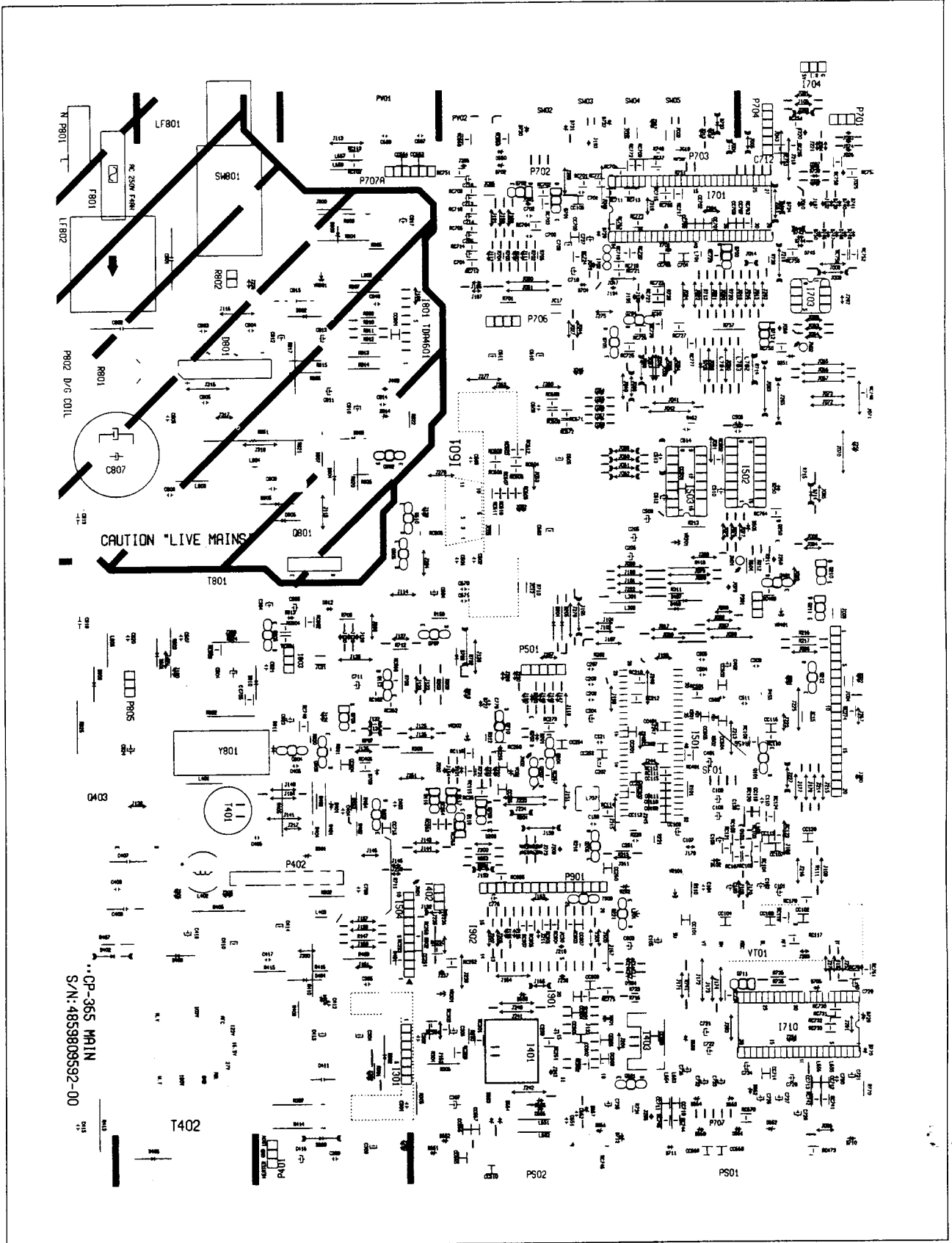

..CP-365 MAIN
S/N:4859809592-00

• NICAM PCB

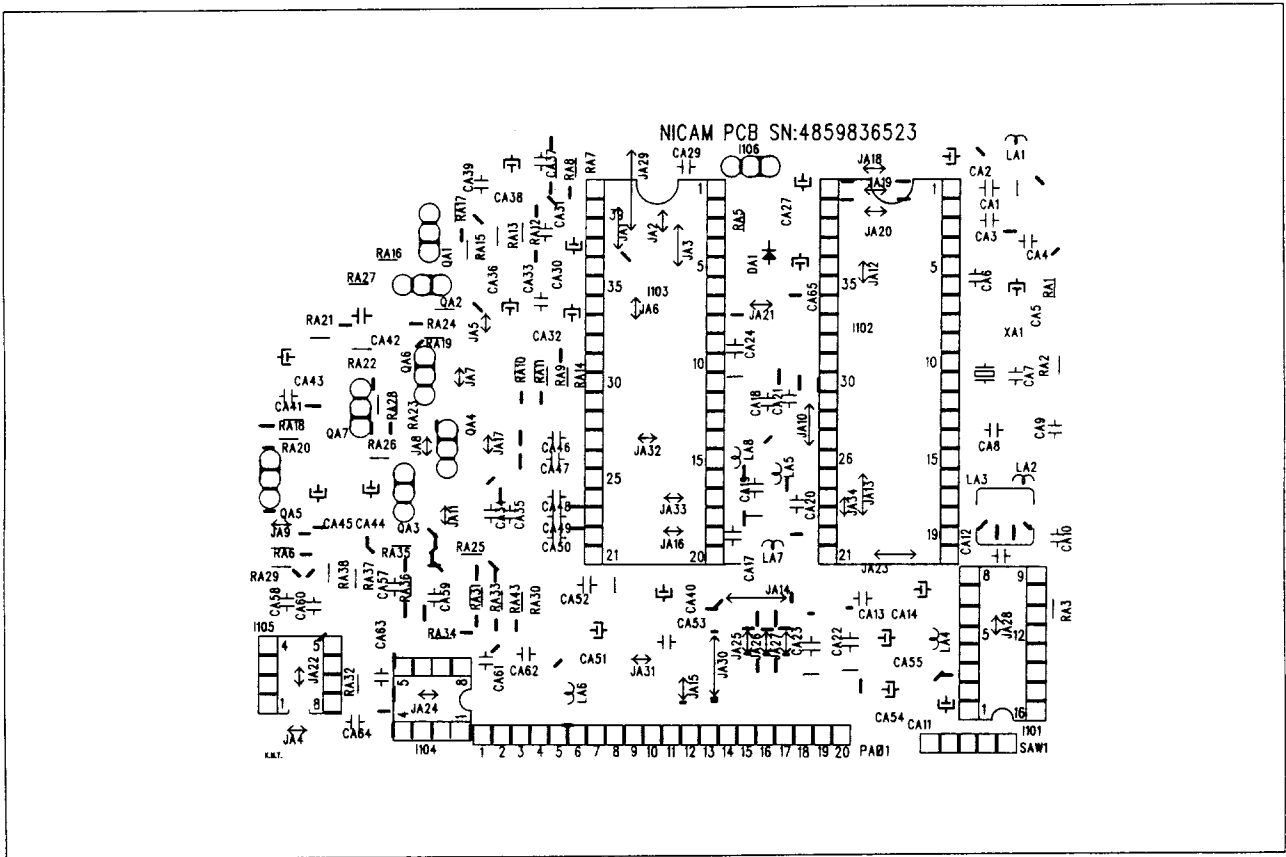

• 2-CARRIER PCB

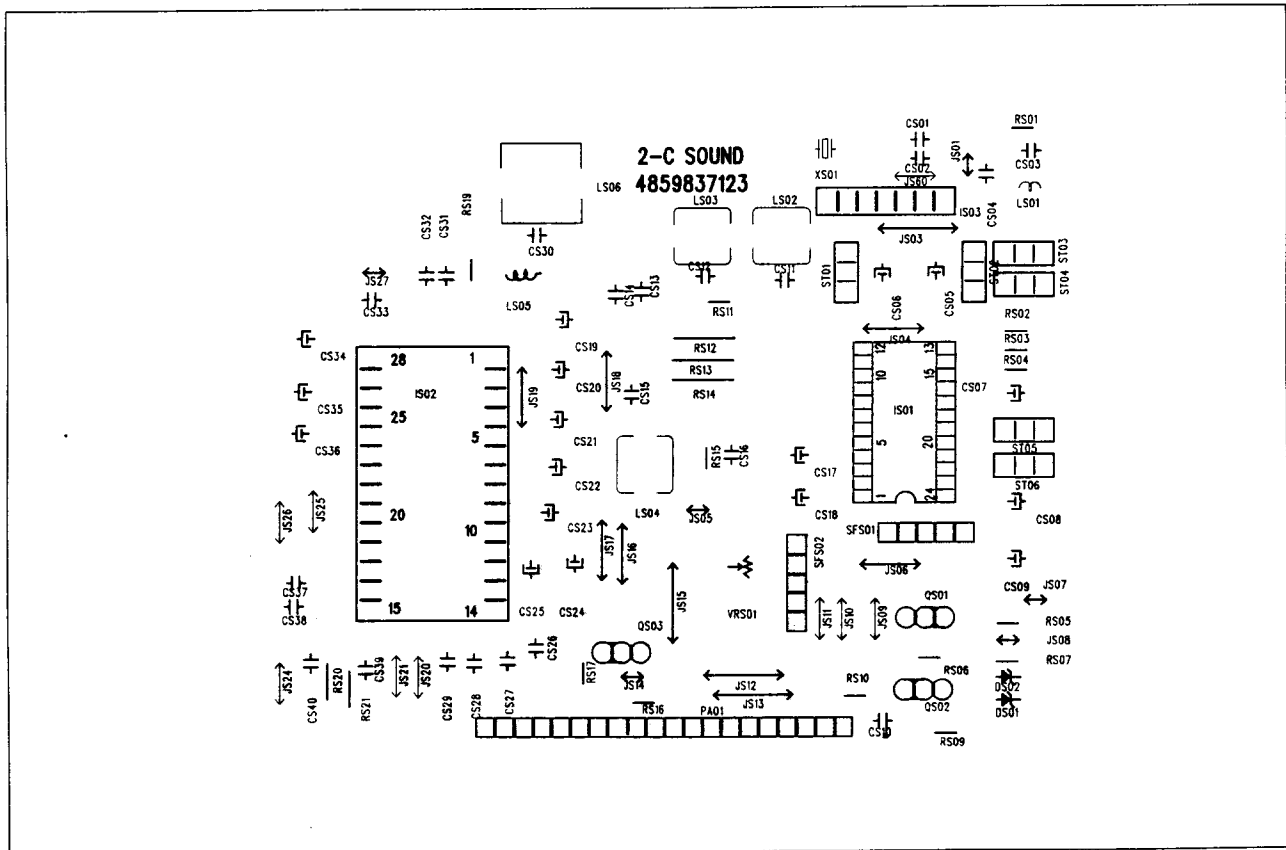

• CRT PCB

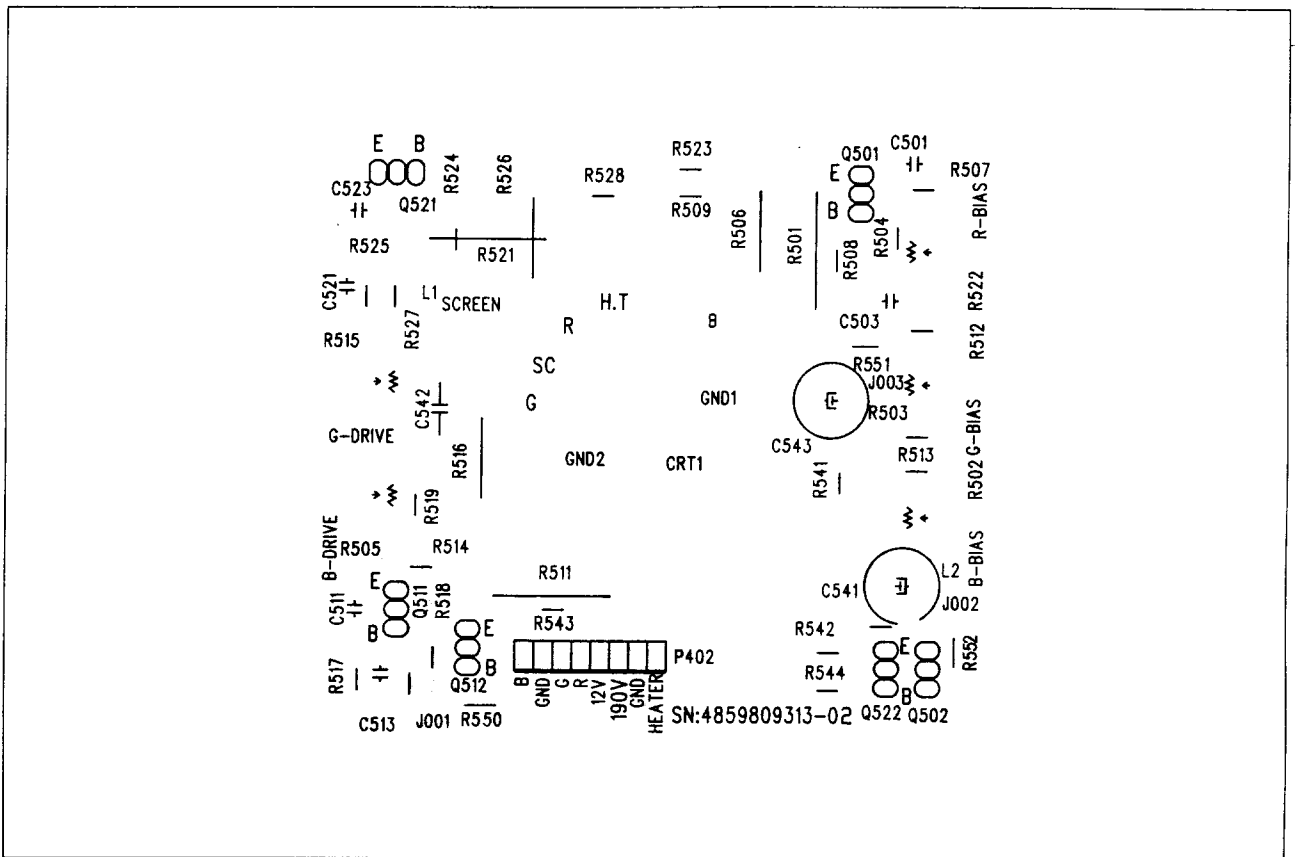

• A/V JACK PCB

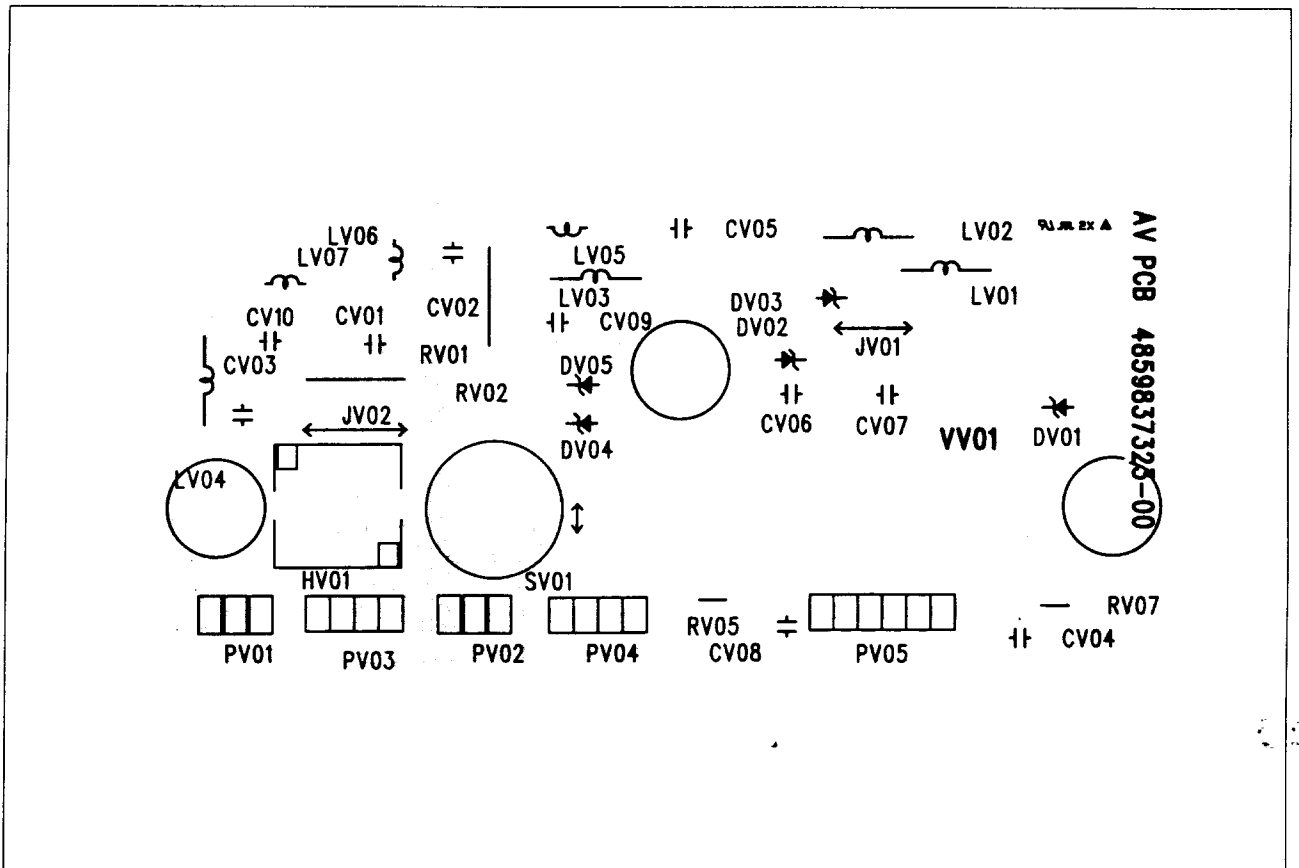

• CONTROL PCB (-C1)

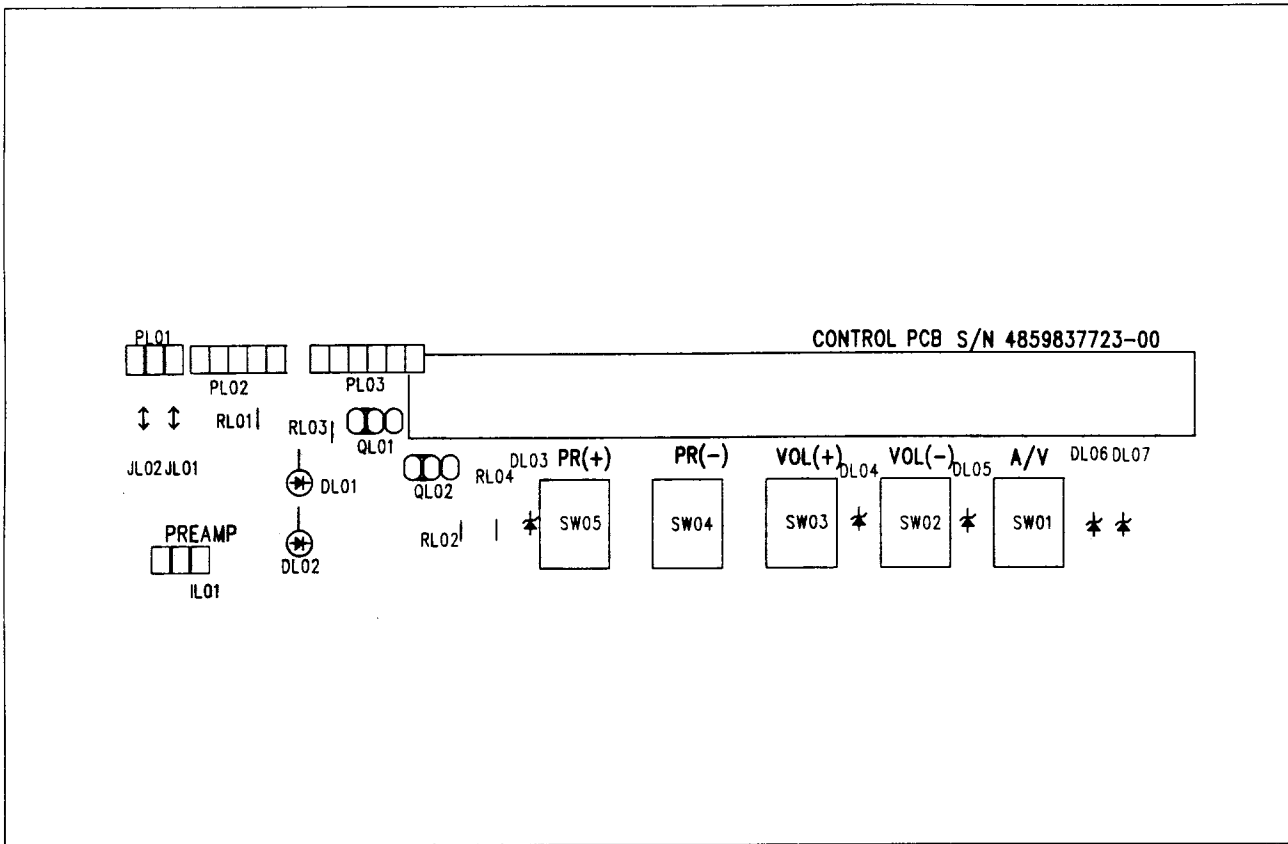

• CONTROL PCB (-2195)

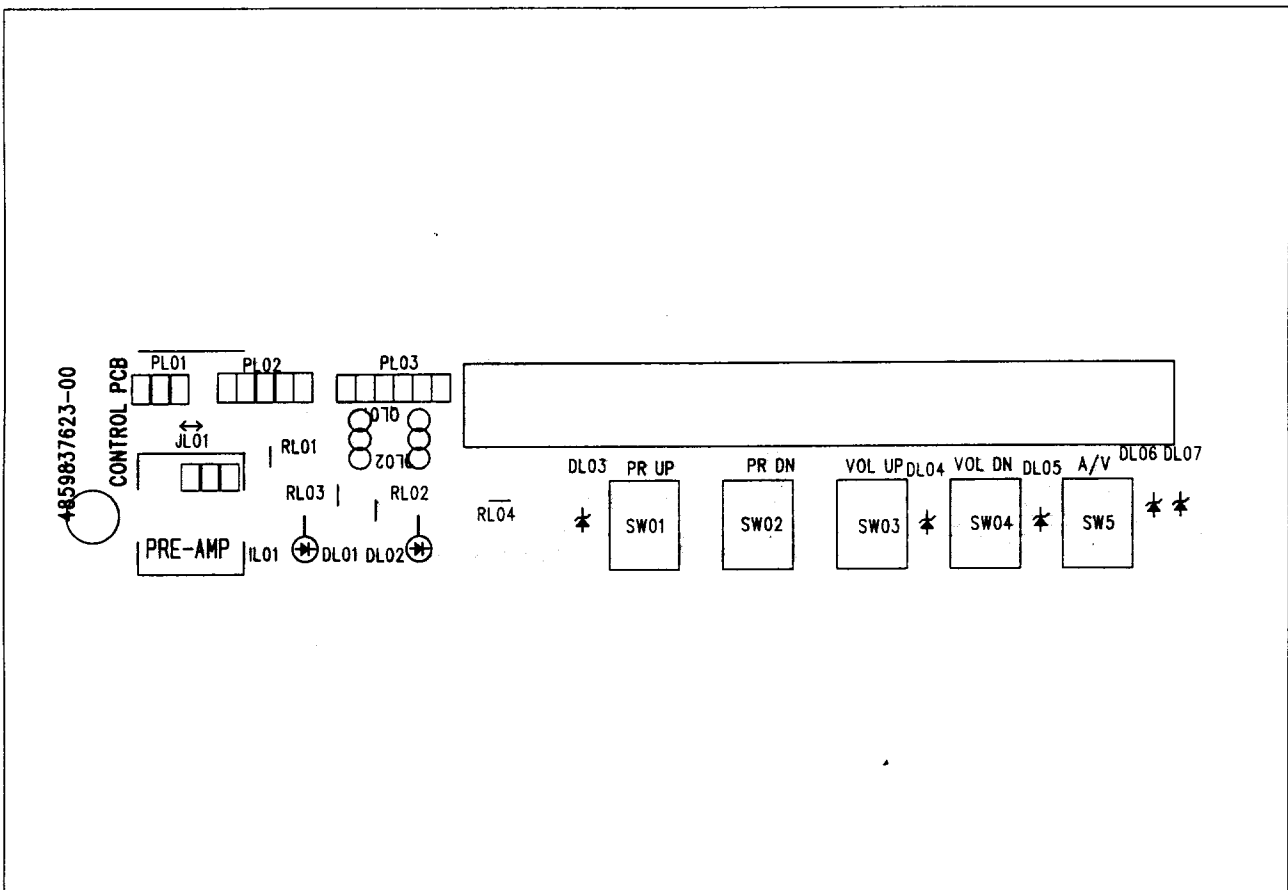

■ TROUBLE SHOOTING CHARTS

■ NO RASTER

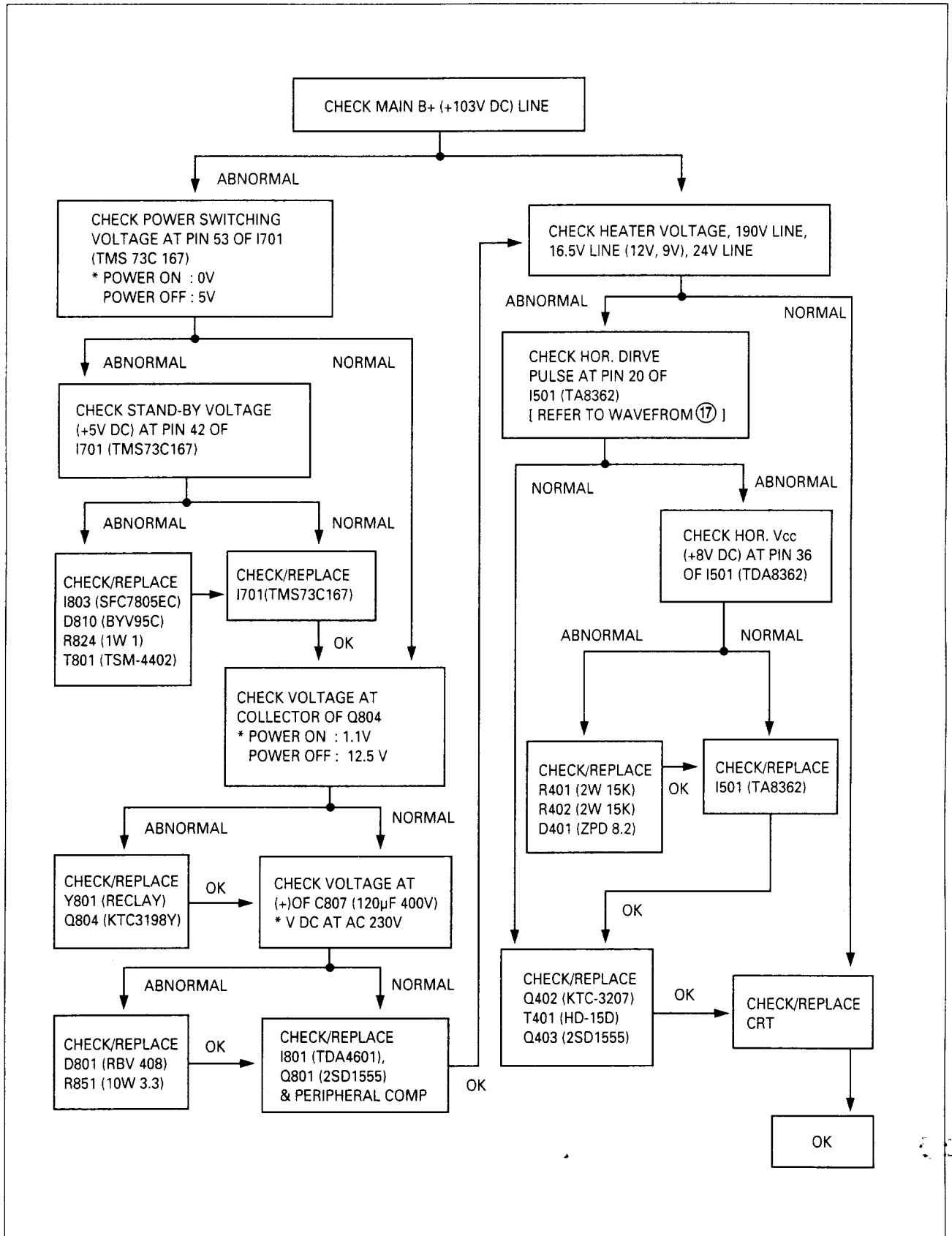

■ NO PICTURE(RASTER OK)

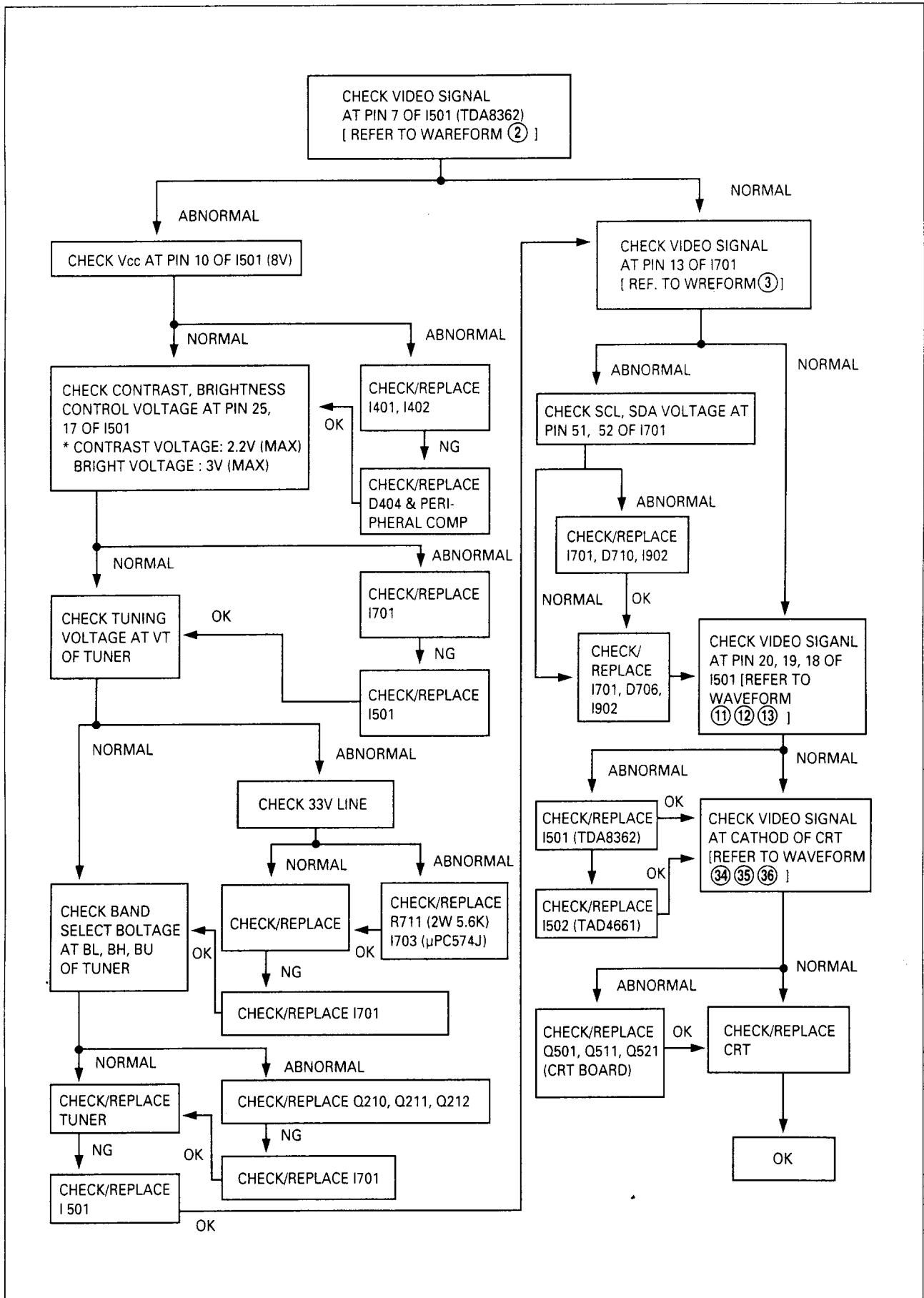

■ AUTO SEARCH TROUBLE (CHANNEL SKIP)

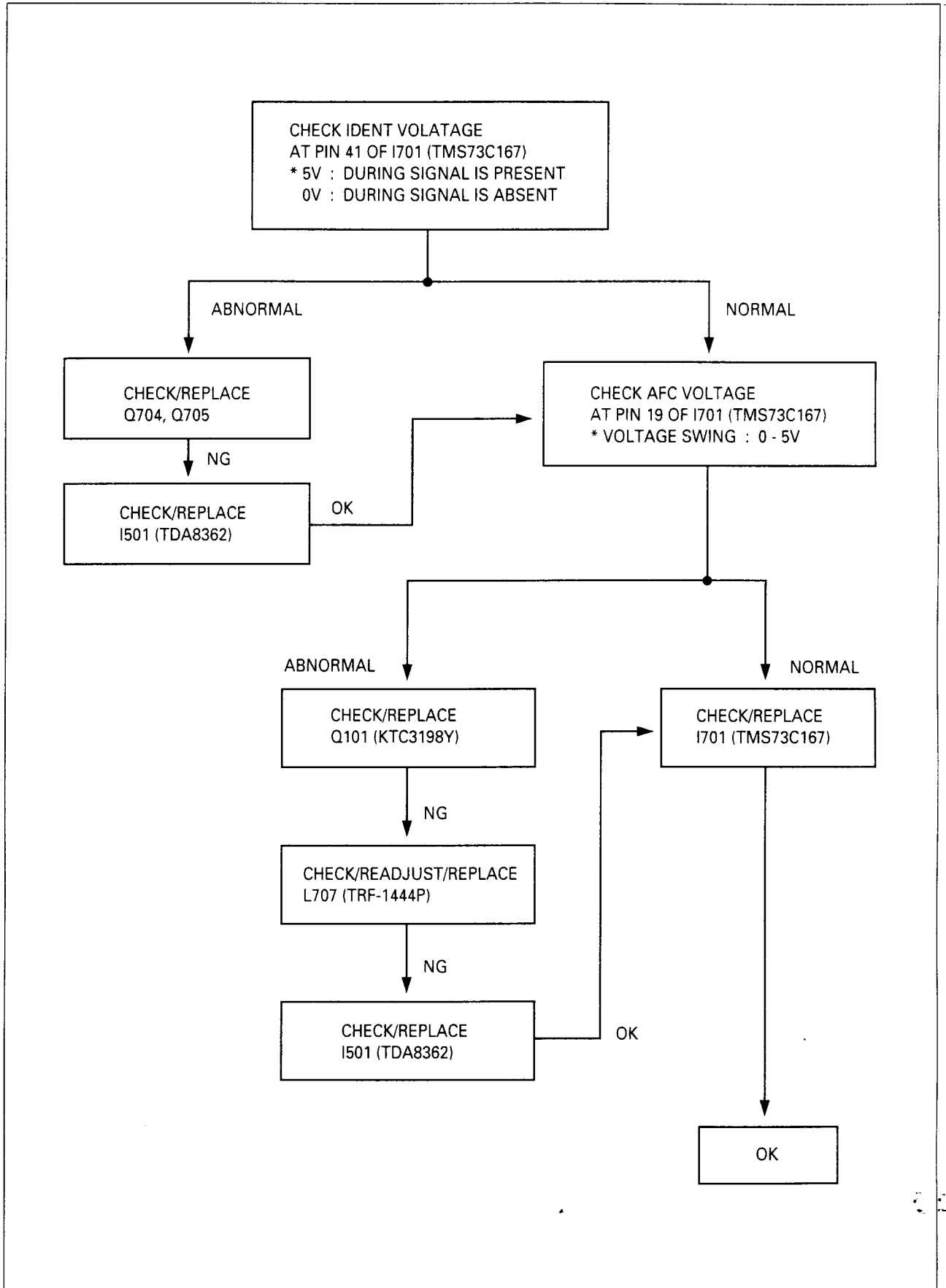

■ NO VERTICAL SCANNING (ONE HORIZONTAL LINE ON SCREEN)

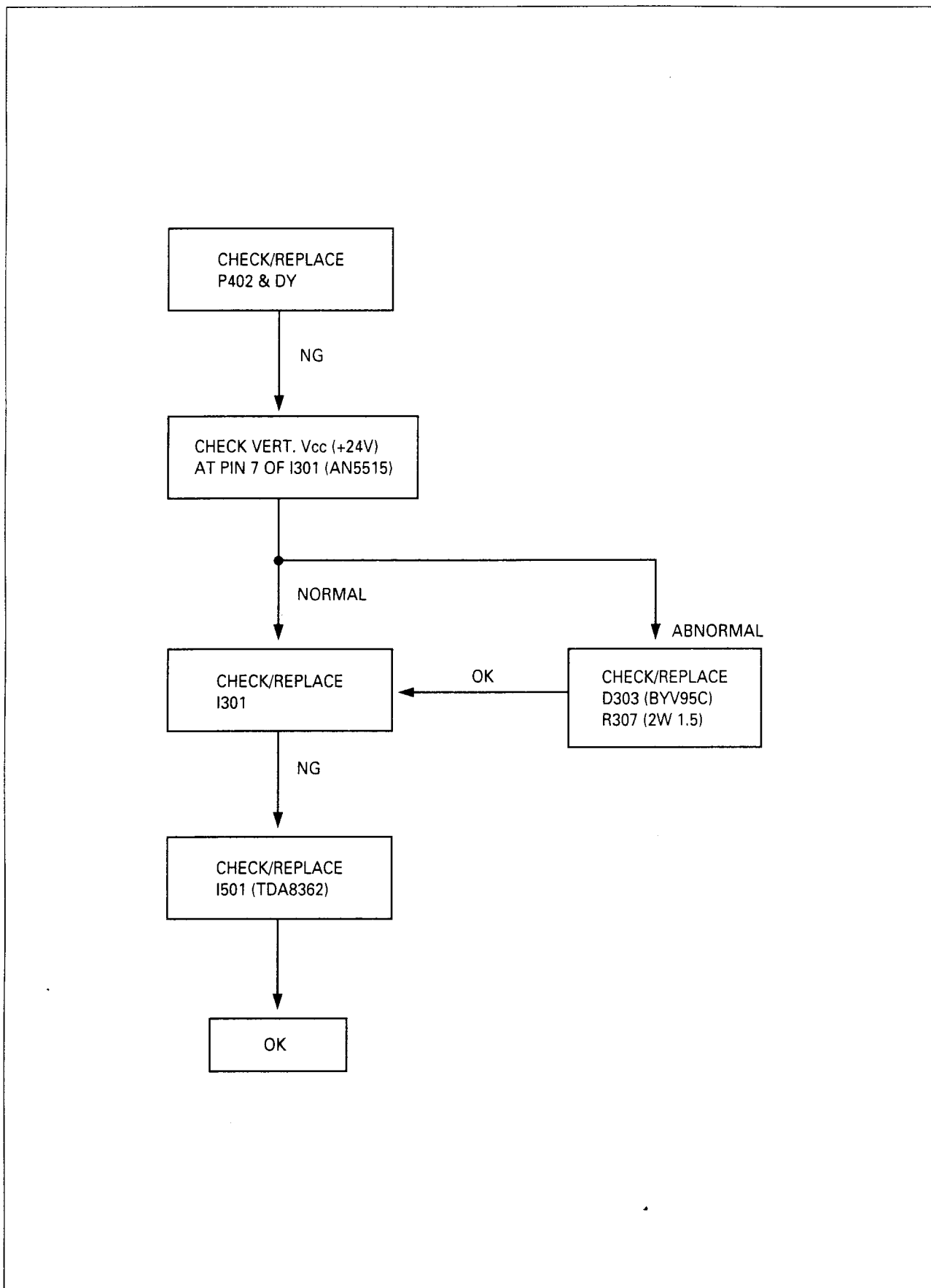

■ NO COLOR

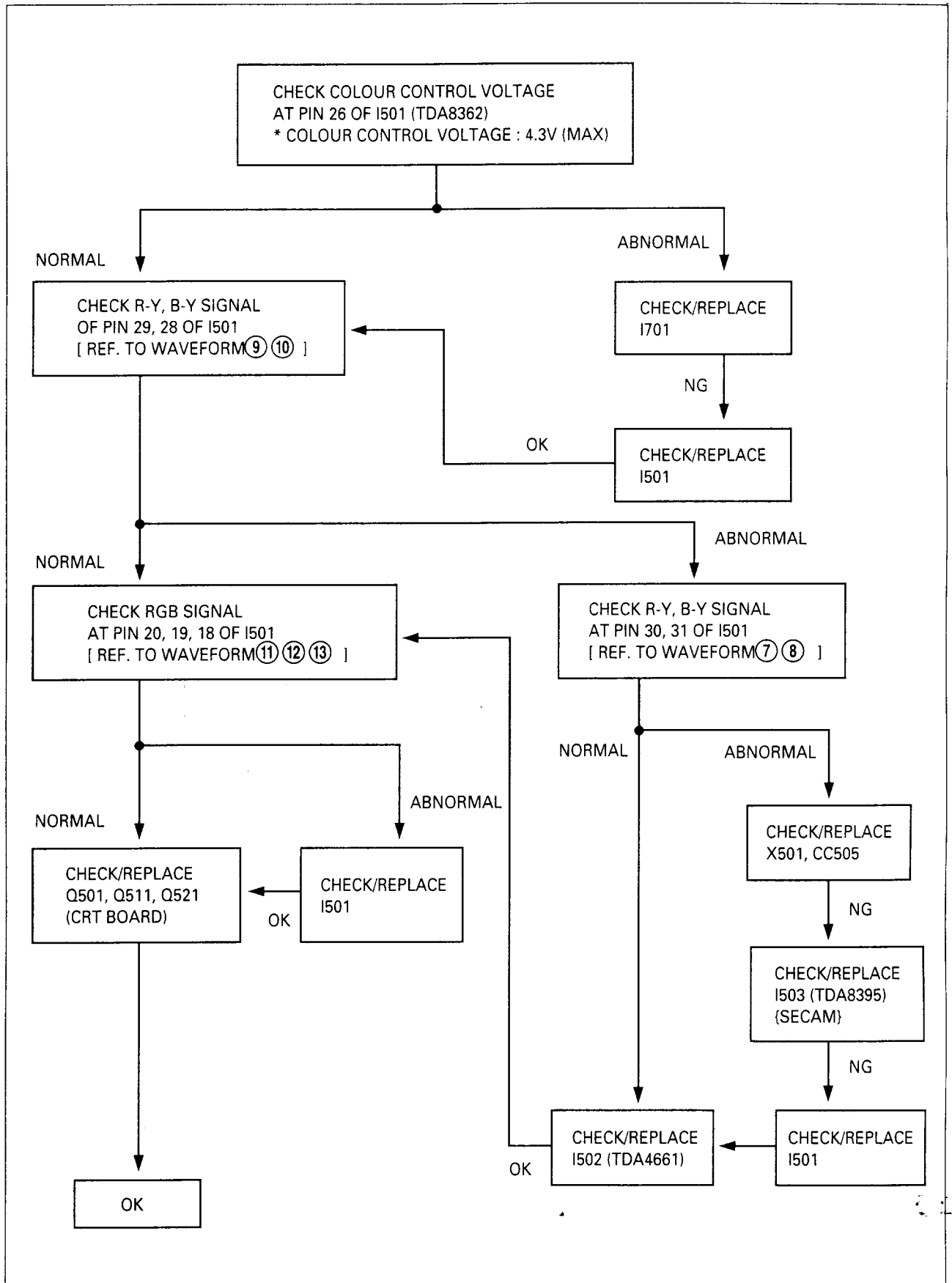

■ NO SPECIFIC COLOR

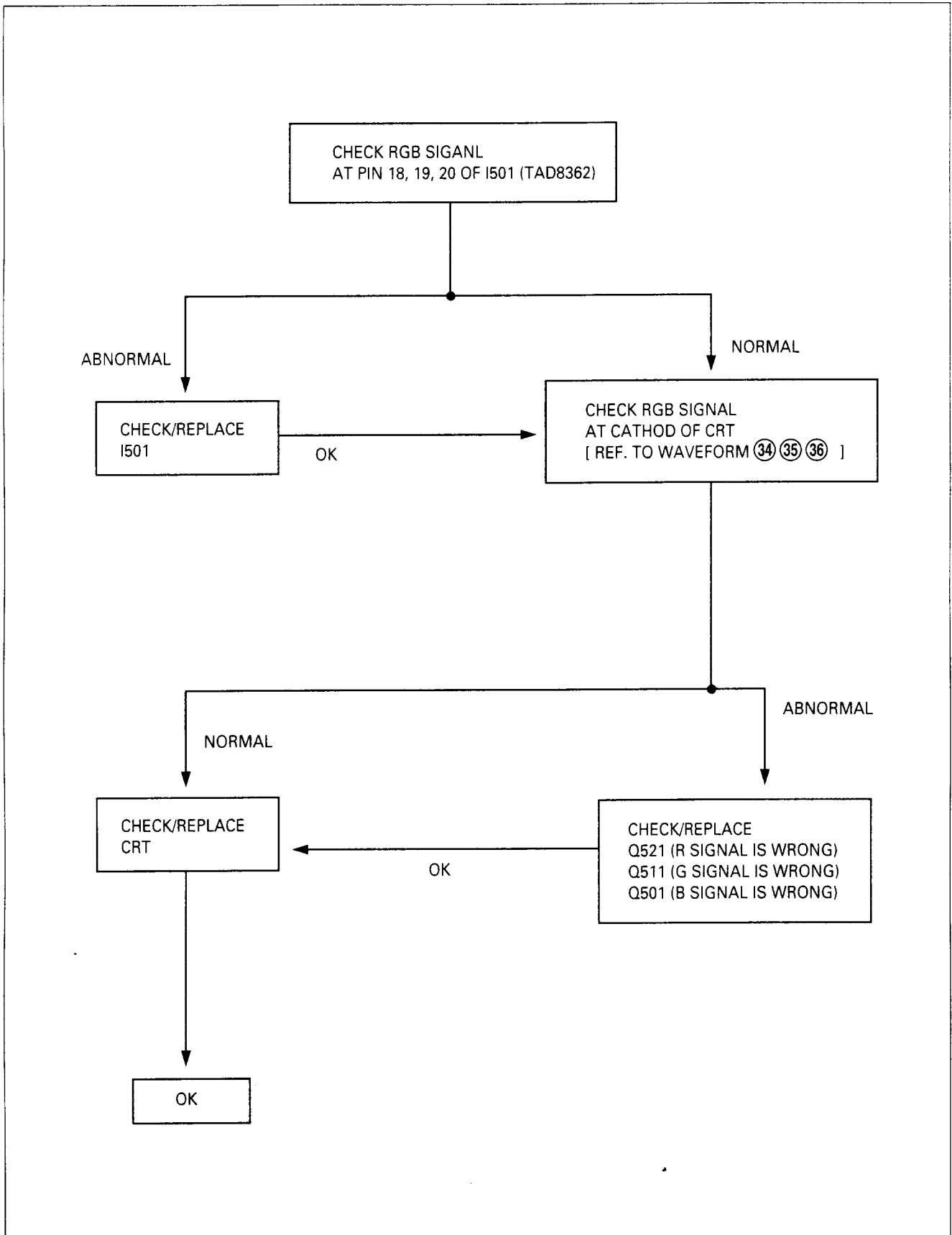

■ NO EXTERNAL AV

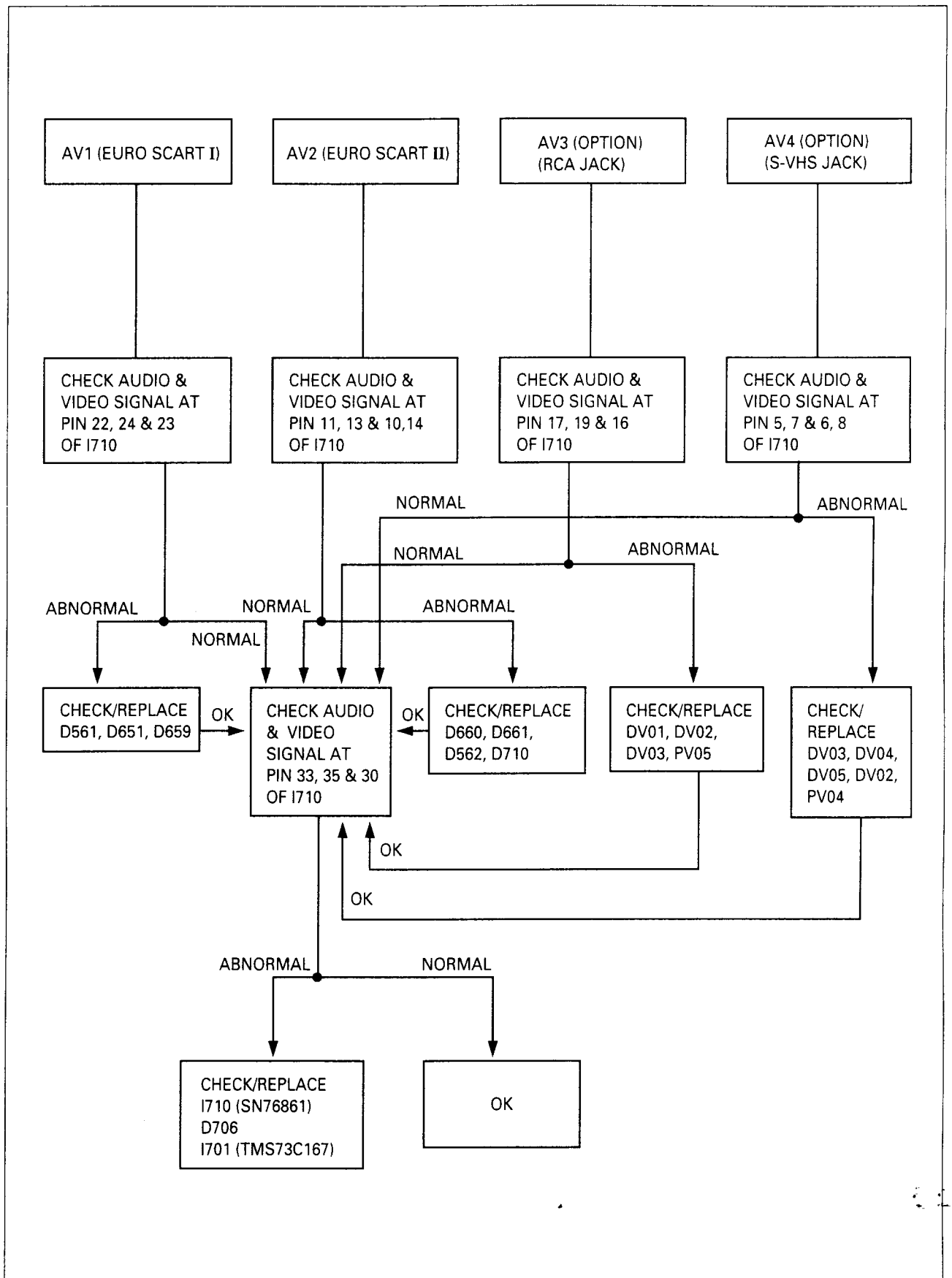

■ NO SOUND (PICTURE OK)

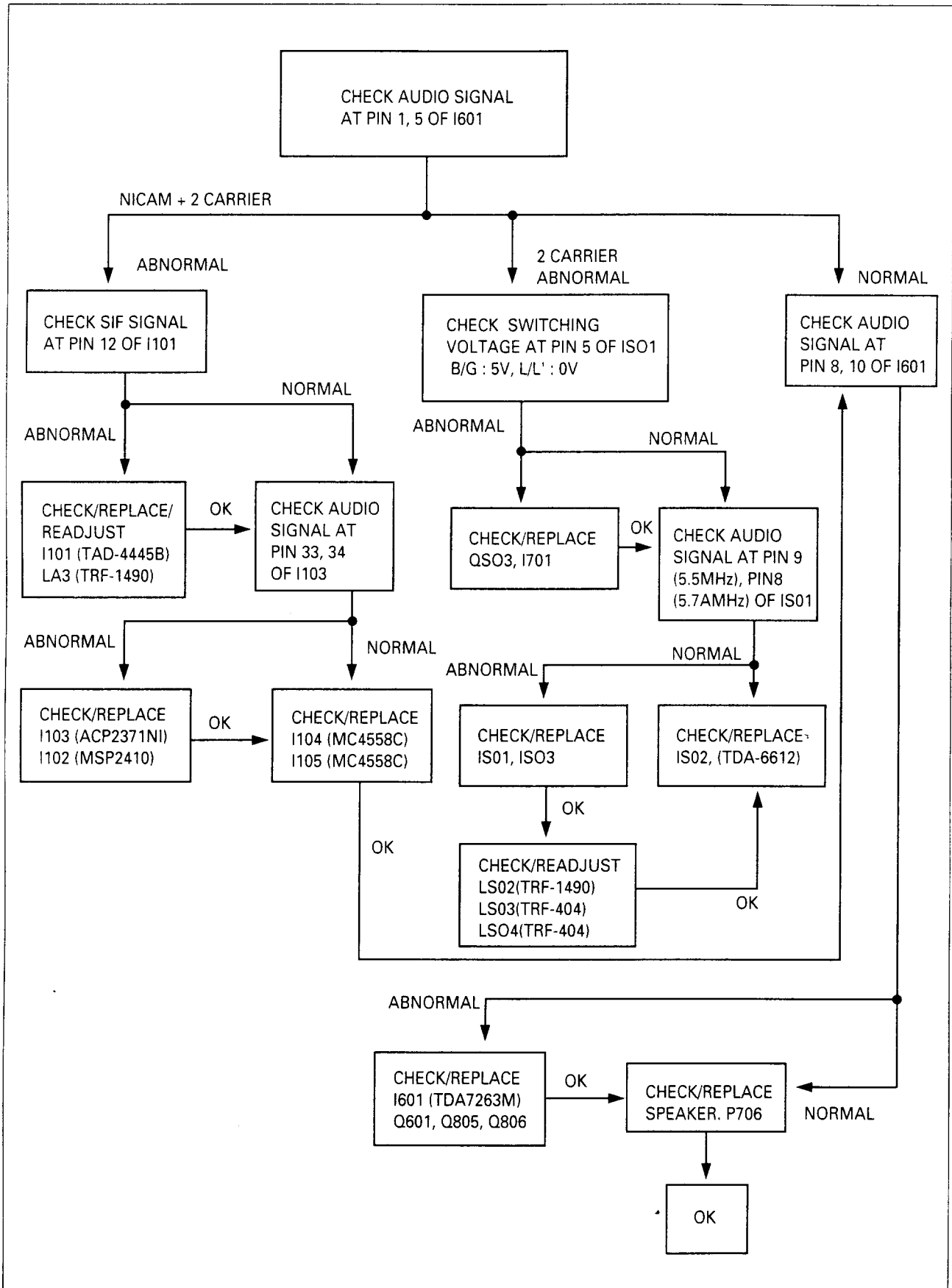

■ ON-SCREEN DISPLAY

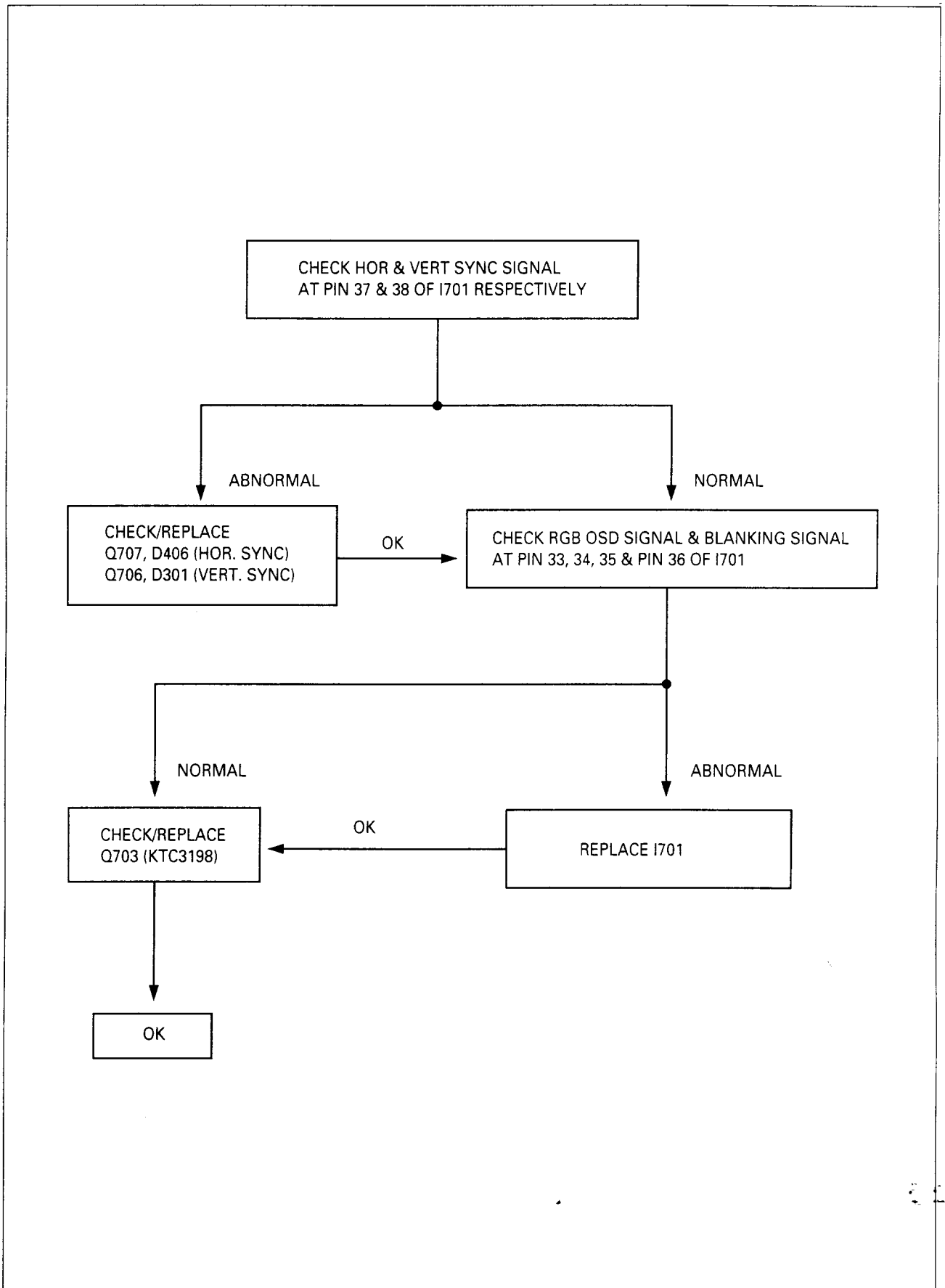

■ REMOTE CONTROL TROUBLE (LOCAL CONTROL OK)

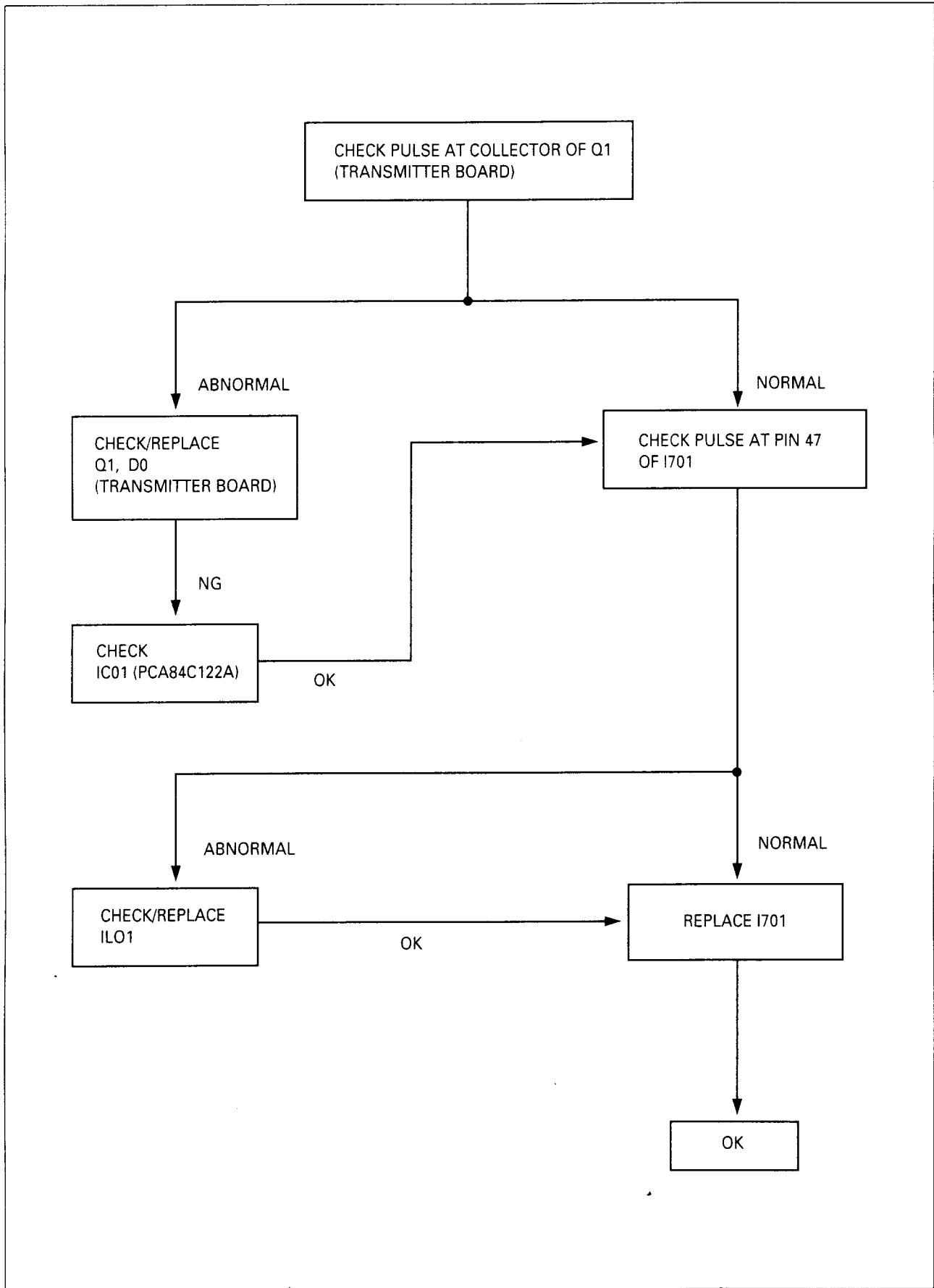

■ NO TELETEXT

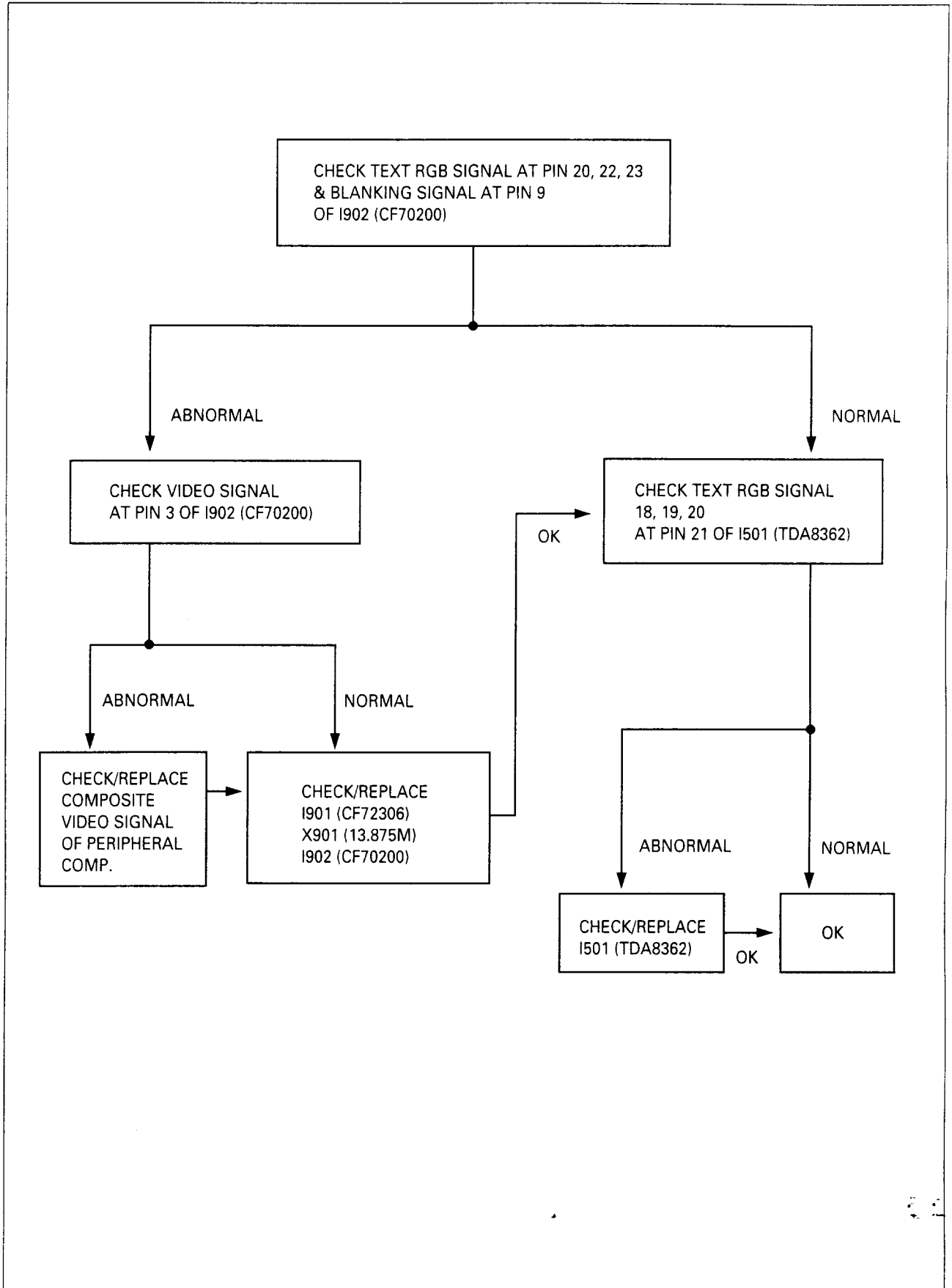

REPLACEMENT PARTS LIST

LOC.	PART-CODE	PART-NAME	PART-DESCRIPTION	REMARK
------	-----------	-----------	------------------	--------

ACCESSORY AS

	4858213800	BAG P.E	P.E FILM T0.05X1150X1000	
	486A716200	BATTERY	AAA	
	48B2823A01	TRANSMITTER REMOCON	R-23A01	
	48B2823A02	TRANSMITTER REMOCON	R-23A02	
	48B2822A01	TRANSMITTER REMOCON	R-22A01	
	48B2822A02	TRANSMITTER REMOCON	R-22A02	

COVER BACK AS

M211	4852134500	COVER BACK	FR HIPS BK	
M541	4855415800	SPEC PLATE	150ART P/E FILM (C/TV)	
M781	4857817610	CLOTH BLACK	FELT T0.7 L = 300	

PACKTING AS

M641	6520010100	STAPLE PIN	18M/M JDC	
M801	4858037100	BOX CARTON	DW-3	
M811	4858165300	PAD	EPS	
M822	4858261300	PE FILM	T0.02X1300X1000 C/TV20	
13100	58G0000074	COIL DEGAUSSING	DC-2070	
	58G0000086	COIL DEGAUSSING	DC-2050	
13200	4851900410	CRT GROUND AS	24/5/0.12-1560+AWG16-450	

CABINET AS

MC01	7128301011	SCREW TAPPING	T2S WAS 3X10 MFZN	
M211A	7122401411	SCREW TAPPING	T2S TRS 4X14 MFZN	
M211B	7122401411	SCREW TAPPING	T2S TRS 4X14 MFZN	
M211C	7122401411	SCREW TAPPING	T2S TRS 4X14 MFZN	
M351	4853525501	HOLDER CORD	HIPS GY	
M481	4854837402	BUTTON POWER	ABS BK	
M481A	4856717900	SPRING	SWPA	
M491A	7128301211	XCREW TAPPING	T2S WAS 3X12 MFZN	
M681	4856812001	TIE CABLE	NYLON66 DA100	
P001	4851900120	SPEAKER GROUND AS	DS-W1007-RC5R6M	
P002	4851900120	SPEAKER GROUND AS	DS-W1007-RC5R6M	
P402A	4850706057	CONN AS	ODY-2109	
SP01A	7128301011	SCREW TAPPING	T2S WAS 3X10 MFZN	
V901	4859605762	CRT	A51JSW 90X40	21" ORION
V901	4859609461	CRT	A51EER 11X40	21" SAMSUNG
V901	4859607660	CRT	A51EAL 55X01	21" PHILIPS
V901	4859611260	CRT	A48EEV 33X01	20" POLKOLOR
V901	4859609561	CRT	A48ECR 11X16	20" SAMSUNG
V901	48A9642091	CRT	A48JLL 90X	20" ORION
V901A	4856214800	WASHER RUBBER	TMR-CA/NF BK T2	
V901B	4856213200	WASHER CRT FIX	SK-5 B.K T1.2	
V905A	7391500011	NUT HEX	6N-1-5 MFZN	
000AA	4855802110	LABEL WARNING	STICKER 100PX600X740	
000BB	4859704500	LABEL CRT BS	STICKER	

LOC.	PART-CODE	PART-NAME	PART-DESCRIPTION	REMARK
------	-----------	-----------	------------------	--------

■ MASK FRONT AS

M201	4852047001	MASK FRONT	HIPS BK	
M251	4852525200	GRILL R	EGI T0.5	
M252	4852525100	GRILL L	EGI T0.5	
M331	4853311601	RETAINER BACK	HIPS NC	
M341	4853414401	BRKT CRT	ABS NC	
M341A	7121401411	SCREW TAPPING	T2S PAN 4X14 MFZN	
M551	4855519001	DECO SENSOR	P.C SMOG	
M561	4855617500	MARK BRAND	CU AU+ABS BK	

■ SPEAKER AS

PV01A	4850703028	CONN AS	YH025-03+YST025+USW = 200	
PV02A	4850703305	CONN AS	YH025-03+YST025+USW = 700	
SP01	4858304920	SPEAK ER	5W 8 CHM MSF-2D4SB53D	

■ TERM ANT BOARD AS

M361	4853624802	TERMINAL ANT	MIPS BK	
M361A	7128261011	SCREW TAPPING	T2S WAS 2.6X10 MFZN	
00010	4859002150	PLUG PHONE AS	SPC+3C-2WS = 150MM	

■ PCB LED AS (2195, 20C1 MODEL)

21210	2193102005	SOLDER BAR	SN PB=63 47 S63S-1320	
21220	2193011101	SOLDER WIRE	RS 60-1.2 1.6A	
21230	2291050301	FLUX SOLVENT	ICAN/14KG H-302	
21240	2291050615	FLUX SOLDER	KS-892M-1	
21250	2291140501	WAX COVER		
21290	2291051001	FLUX KILLER	KFT-7	
A001	4859837723	PCB CONTROL	T1.6X143X37(293X139/2X3)	
DL01	DKLR114L--	LED	KLR114L	
DL02	DKLR114L--	LED	KLR114L	
DL03	DZPD6R2---	DIODE ZENER	ZPD6.2	
DL04	DZPO6R2---	DIODE ZENER	ZPD6.2	
DL05	DZPD6R2---	DIODE ZENER	ZPD6.2	
DL06	DZPD6R2---	DIODE ZENER	ZPD6.2	
DL07	DZPD6R2---	DIODE ZENER	ZPD6.2	
IL01	1SR9HP----	IC PREAMP	SR-9HP	
IL01	1R0101DBK-	IC PREAMP	R01-01D (BK)	
M491	4854920701	BUTTON	ABS BK	
M681	4856812001	TIE CABLE	NYLON66 DA100	
PL01A	4850703306	CONN AS	YH025-03+YST025+USW = 500	
PL02	4850705020	CONN AS	YH025-05+YST025+ULW = 500	
PL03	4850706013	CONN AS	YN025-06+YST025+ULW = 500	
QL01	TKTC3198Y-	TR	KTC3198Y	
QL02	TKTC3198Y-	TR	KTC3198Y	
RL01	RD-AZ472J-	R CARBON FILM	1/6 4.7K OHM J	
RL02	RD-AZ472J-	R CARBON FILM	1/6 4.7K OHM J	
RL03	RD-AZ391J-	R CARBON FILM	1/6 390 OHM J	

LOC.	PART-CODE	PART-NAME	PART-DESCRIPTION	REMARK
RL04	RD-AZ391J-	R CARBON FILM	1/6 390 OHM J	
SW01	5SB0101166	SW TACT	KPT-1105A	
SW02	5SB0101166	SW TACT	KPT-1105A	
SW03	5SB0101166	SW TACT	KPT-1105A	
SW04	5SB0101166	SW TACT	KPT-1105A	
SW05	5SB0101166	SW TACT	KPT-1105A	

■ PCB MAIN MANUAL AS

C202	CEXF1C471V	C ELECTRO	16V RSS 470MF (10X12.5) TP	
C303	CEYF1V102V	C ELECTRO	35V RSS 1000MF (13X25)	
C307	CEYF1V222V	C ELECTRO	35V RSS 2200MF (16X31.5)	
C305	CEYF1V222V	C ELECTRO	35V RSS 220MF (1631.5)	
C402	CEXE1H479A	C ELECTRO	50V RS 4.7MF	
C405	CCYB3A222K	C CERA	1KV B 2200PF K	
C407	CMYH3C822J	C MYLAR	1.6KV 8200PF J (BUP)	20" S/S
C407	CMYH3C692J	C MYLAR	1.6KV 6900PF J	21" PHILIPS, S/S
C407	CMYH3C752J	C MYLAR	1.6KV 7500PF J	20" ORION
C408	CMYH3C102J	C MYLAR	2KV 1000PF J	20" POLKOLOR
C408	CMYH3C471J	C MYLAR	2KV 470PF J	20" ORION
C409	CMYE2D474J	C MYLAR	200V 0.47MF J (PL)	20" S/S
C409	CMYE2D154J	C MYLAR	200V 0.15MF J	20" ORION CRT
C409	CMYE2D334F	C MYLAR	200V 0.33MF J	21" PHILIPS CRT
C409	CMYE2D364J	C MYLAR	200V 0.36MF J	20" SAMSUNG CRT
C409	CMYE2D394J	C MYLAR	200V 0.39MF J	21" ORION
C410	CEYF2C330V	C ELECTRO	160V RSS 32MF (13X20)	21" SAMSUNG
C411	CMYE2D104J	C MYLAR	200V 0.1MF J (PL)	20" POLKION
C412	CCYB3A102V	C CERA	1KV B 1000PF K	
C413	CEYF1E471V	C ELECTRO	25V RSS 470MF (10X20)	
C414	CEYE2C330C	C ELECTRO	160V RU 33MF (13X25)	
C416	CEXE2E339A	C ELECTRO	250V RS 3.3MF (8X16)	
C514	CMXM2A224J	C MYLAR	100V 0.22MF J	
C607	CCYB3A102K	C CERA	1KV B 1000PF K	
C610	CEYF1V102V	C ELECTRO	35V RSS 1000MF (13X25)	
C611	CEYF1V102V	C ELECTRO	35V RSS 1000MF (13X25)	
C630	CEXF1V471V	C ELECTRO	35V RSS 470MF (13X25)	
C709	CEYF1C102V	C ELECTRO	16V RSS 1000MF (10X20)	
C735	CEYF1C102V	C ELECTRO	16V RSS 1000MF (10X20)	
C801	CL1JB3474K	C LINE ACROSS	AC250V 0.47MF 7/C/SNDF/SV	
C802	CL1JB3474K	C LINE ACROSS	AC250V 0.47MF U/C/SNDF/SV	
C803	CCYF3A472Z	C CERA	1KV F 4700PF Z	
C804	CCYF3A472Z	C CERA	1KV F 4700PF Z	
C805	CCYF3A472Z	C CERA	1KV F 4700PF Z	
C806	CCYF3A472Z	C CERA	1KV F 4700PF Z	
C807	CEYM2G121T	C ELECTRO	400V LWF 120MF (25X50)	
C808	CCYB3A271K	C CERA	1KV B 270PF K	
C809	CMYH3C122J	C MYLAR	BUP 1.6KV 1200PF J	

LOC.	PART-CODE	PART-NAME	PART-DESCRIPTION	REMARK
C815	MYB2G822J	C MYLAR	400V 8200PF J (ED)	
C818	CH1FFF103M	C CERA AC	AC400V 10000PF F DE7150	
C 819	CH1FFF103M	C CERA AC	AC400V 10000PF F DE77150	
C820	CCYB3A102K	C CERA	1KV B 1000PF K	
C823	CEYF1C102V	C ELECTRO	16V RSS 1000MF (10X20)	
C824	CEYF2C101C	C ELECTRO	160V RUS 100MF (16X25)	
C850	CEYE2C330C	C ELECTRO	160V RCI 33MF (13X25)	
C904	CEYF1V102C	C ELECTRO	35V RUS 1000MF (13X25)	
D403	DBYW95C---	DIODE	BYW95C	
D601	DBYW95C---	DIODE	BYW95C	
D703	1UPC574J--	IC	UPC574J	
D801	DRBV408---	DIODE BRIDGE	RBV-408	
D809	DBYW95C---	DIODE	BYW95C	
F801	5FSCB4022R	FUSE CERA	SEMKO F4AH 4A 250V MF51	
F801C	4857621200	INSU COVER	PCV T1.0 94V-0	
I301	1AN5515---	IC	AN5515	
I301A	4857024601	HEAT SINK	AL EX	
I301B	7121300811	SCREW TAPPING	T25 PAN 3X8 MFZN	
I401	IL7812CV--	IC REGULATOR	L7812CV	
I401A	4857024900	HEAT SINK	AL EX	
I401B	7121301011	SCREW TAPPING	T2S PAN 3X10 MFZN	
I402	1KA7808---	IC REGULATOR	KA7808	
I403	1MC7805C--	IC REGULATOR	MC7805C(KA7805)	
I403A	4857024902	HEAT SINK	AL EX	
I403B	7121300811	SCREW TAPPING	T2S PAN 3X8 MFZN	
I501	1TDA8362B-	IC	TDA83628	TF, TS, TK, TU
I501	1TDA8362--	IC	TDA8362	VA
I502	1TDA4661--	IC	TDA4661	
I503	1TDA8395--	IC	TDA8395	TK, VA
I504	1LA7950---	IC	LA-7950	TK
I601	1TDA7263M-	IC	TDA7263M	
I601A	4857024405	HEAT SINK	AL EX	
I601B	7271301011	SCREW TAPTITE	TT3 PAN 3X10 MFZN	
I701	1DW167ST02	IC MICOM	TM73C167A	
I702	1K1A7042P-	IC SWITCH	KIA7042P	
I703	1CAT24CO8P	IC	CAT24CO8P	
I710	1SN7686INJ	IC	SN7686INJ-12	
I801	1TDA4601--	IC	TDA4601	
I801A	4857025401	HEAT SINK	A1050P-J24 T2	
I801B	4856012310	SCREW SPECTAL	PAN 3X10 MFZN	
I801C	4856215200	WASHER	SPCC	
I801D	7392300011	NUT HEX	6N-2-3 MFZN	
I801L	4855801719	LABEL WARNING	STICKER 50X10	
I803	1MC7805C--	IC REGULATOR	MC7805C(KA7805)	
I803A	4857024900	HEAT SINK	AL EX	

LOC.	PART-CODE	PART-NAME	PART-DESCRIPTION	REMARK
I803B	7121301011	SCREW TAPPING	T2S PAN 3X10 MFZN	
I901	1CF72306--	IC	CF72306	
I902	1CF70200--	IC	CF70200NW	
I903	1K1A70420-	IC SWITCH	KIA7042P	
JW02	WP-1BL201Y	WIRE LEAD 1007	#22 1/0.65 BL 5F-200-5	
LF801	5PLF303---	FILTER LINE	LF-303	
LF802	5PLF3544B-	FILTER LINE	LF-3544B	
L103	58C9780027	COIL CHOKE	TRF-1201B (0.97 UH)	
L401	58C0000026	COIL BEAD	HC-4035	
L402	58H0000020	COIL LINEARITY	L-76(76.5 UH)	20" POLKOLAR 21" PILIPS
L402	58H0000034	COIL LINEARITY	L-62	20" S/S WF
L402	58H0000016	COIL LINEARITY	L-102	20",21" ORION 21" S/S WF
L403	58C9430599	COIL CHOKE	AZ-9004Y (94MH)	
L707	58B38R9061	COIL PIF	TRF-1444P	
L802	58C0000026	COIL BEAD	HC-4035	
L803	58C0000026	COIL BEAD	HC-4035	
L805	58C0000026	COIL BEAD	HC-4035	
L808	58C4500079	COIL CHOKE	L-45	
M721	4857235400	SHIELD CASE	SPTH-C T0.25	
PL01	4859231620	CONN WAFER	YW025-03	
PL02	4859231820	CONN WAFER	YW025-05	
PL03	4859231920	CONN WAFER	YW025-06	
PS01	4859200401	SOCKET RGB	SR-21A1 (ANGLE TYPE)	
PS02	4859200401	SOCKET RGB	SR-21A1 (ANGLE TYPE)	
PV03	4859231720	CONN WAFER	YW025-04	
PV04	4859231720	CONN WAFER	YW025-04	
PV05	4859231720	CONN WAFER	YW025-04	
P301	4859231620	CONN WAFER	YW025-03	
P401	4859231620	CONN WAFER	YW025-03	
P402	4859240120	CONN WAFER	YFW500-06	
P501	4859231820	CONN WAFER	YW025-05	
P801	4859242220	CONN WAFER	YFW800-02	
P801A	4859904110	CORD POWER AS	CW3201/250V 5A+HOUS=2500	TU
P801A	4859903110	CORD POWER AS	CW4232/250V 5A	TF
P801A	4859901419	CORD POWER AS	KKP419L/250 TA	TS, TK, VA.
A0001	4859904811	CORD POWER	CW3201 H03VVH2F L-2500	
A0002	4855801619	LABEL WARNING	PAPER 93X44	
P802	4859242220	CONN WAFER	YFW800-02	
P805	4859231620	CONN WAFER	YW025-03	
Q102	TKTC3197--	TR	KTC 3197	
Q403	T2SD1555--	TR	2SD1555	
Q403A	4857024502	HEAT SINK	AL EX	
Q403B	4856012312	SCREW SPECIAL	PAN 3X12 MFZN	
Q403C	7392300011	NUT HEX	6N-2-3 MFZN	
Q403D	4856215201	WASHER	SPCC	

LOC.	PART-CODE	PART-NAME	PART-DESCRIPTION	REMARK
Q801	T2SD1555--	TR	2SD1555	
Q801A	4857024502	HEAT SINK	AL EX	
Q801B	4856012312	SCREW SPECIAL	PAN 3X12 MFZN	
Q801C	7392300011	NUT HEX	6N-2-3 MFZN	
Q801D	4856215201	WASHER	SPCC	
R307	RF02Y159J-	R FUSTBLE	2W 1.5 OHM J	
R401	RS02Y153J-	R M-OXIDE FILM	2W 15K OHM J	
R402	RS02Y153J-	R M-OXIDE FILM	2W 15K OHM J	
R404	RS02Y512J-	R M-OXIDE FILM	2W 5.1K OHM J	
R405	RS02Y512J-	R M-OXIDE FILM	2W 5.1K OHM J	
R406	RS02Y561J-	R M-OXIDE FILM	2W 560 OHM J	
R410	RF02Y159J-	R FUSIBLE	2W 1.5 OHM J	
R413	RF02Y109J-	R FUSIBLE	2W 1 OHM J	
R414	RF01Y689JA	R FUSIBLE	1W 6.8 OHM J CURVE	20" ORION
R414	RF026279JA	R FUSIBLE	2W 2.7 OHM J	21" ORION, S.S. PHILIPS
R456	RS01Y473J-	R M-OXIDE FILM	1W 47K OHM J	20" S/S, POLKOLAR
R711	RS02Y562J-	R M-OXIDE FILM	2W 5.6K OHM J	TF, TS, VA, TU
R801	D262BF140M	POSISTOR	PTH451C262BF140M270	21"
R801	D202BF180N	POSISTOR	PTH451C202BG180N270	20"
R802	DB59346P20	POSISTOR	B59346-A1502-P20	
R804	RS02Y272J-	R M-OXIDE FILM	2W 2.7K OHM J	
R807	RS01Y688JS	R M-OXIDE FILM	1W 0.68 OHM J SMALL	
R817	RS02Y101J-	R M-OXIDE FILM	2W 100 OHM J	
R820	RX058360JE	R CEMENT	5W 36 OHM J BENCH 12.5MM	
R824	RF01Y109J-	R FUSIBLE	1W 1 OHM J	
R825	RS02Y104J-	R M-OXIDE FILM	2W 100K OHM J	
R832	RF02Y109J-	R FUSIBLE	2W 1 OHM J	
R833	RF02Y279J-	R FUSIBLE	2W 2.7 OHM J	
R851	RX10B339JK	R CEMENT	10W 3.3 OHM J BENCH 25MM	
R903	RF02Y109J-	R FUSIBLE	2W 1 OHM J	
SF01	5PJ3950M--	FILTER SAW	J3950M	TU
SF01	5PG3962M--	FILTER SAW	G3962M	
SW801	5S40102073	SW PUSH	ME-7 1C 2P	
T401	50D0000022	TRANS DRIVE	HD-15D	
T402	50H0000124	FBT	FSA17013M	20" S/S, 21" PHILIPS
T402	50H0000142	FBT	FSA26012M	POLKOLAR
T402	50H0000120	FBT	DCF-2217J	20" POLKOLAR
T402	50H0000124	FBT	DCF-2217L	20" ORION
T801	50M0000083	TRANS SMPS	TSM-4402	21" ORION
VT101	4859710330	TUNER VARACTOR	DET7BZ	TU
VT101	4859709130	TUNER VARACTOR	VTSS7SZ3	TK
VT101	4859709830	TUNER VARACTOR	TEKE4-073A	TF, VA, TS
X501	5XE4R4336E	CRYSTAL QUARTZ	HC-49/U 4.433619MHZ 30PPM	
X502	5XE3R5820C	CRYSTAL QUARTZ	3.58MHZ	TK
X701	5XE6R0000C	CRYSTAL QUARTZ	HC-49/U 6.0000MHZ 20PPM	

LOC.	PART-CODE	PART-NAME	PART-DESCRIPTION	REMARK
X901	5XE13R875E	CRYSTAL QUARTZ	HC-49/U 13.87500MHZ 30PPM	
Y801	5SC0101003	SW RELAY	DG12D1-0M 1C-1P	

■ PCB CHIP MOUNT AS

CC101	HCFK103ZCA	C CHIP CERA	Y5V 50V 0.01MF Z 2012	
CC102	HCFK103ZCA	C CHIP CERA	Y5V 50V 0.01MF Z 2012	
CC103	CHFK103ZCA	C CHIP CERA	Y5V 50V 0.01MF Z 2012	
CC104	HCFK103ZCA	C CHIP CERA	Y5V 50V 0.01MF Z 2012	
CC105	HCQK221JCA	C CHIP CERA	50V CH 220PF J 2012	
CC107	HCFK103ZCA	C CHIP CERA	Y5V 50V 0.01MF Z 2012	
CC108	HCBK223KCA	C CHIP CERA	X7R 40V 0.022MF K 2012	
CC109	HCBK223KCA	C CHIP CERA	X7R 50V 0.022MF K 2012	
CC110	HCFK104ZCA	C CHIP CERA	Y5V 50V 0.1MF Z 2012	
CC111	HCBK223KCA	C CHIP CERA	X7R 50V 0.022MF K 2012	
CC112	HCBK392KCA	C CHIP CERA	X7R 50V 3900PF K 2012	
CC115	HCBK472KCA	C CHIP CERA	X7R 50V 4700PF K 2012	
CC116	HCBK222KCA	C CHIP CERA	X7R 50V 2200PF K 2012	
CC118	HCFK103ZCA	C CHIP CERA	Y5V 50V 0.01MF Z 2012	
CC119	HCFK103ZCA	C CHIP CERA	Y5V 50V 0.01MF Z 2012	
CC120	HCFK103ZCA	C CHIP CERA	Y5V 50V 0.01MF Z 2012	
CC201	HCFK104ZCA	C CHIP CERA	Y5V 50V 0.1MF Z 2012	
CC251	HCFK683ZCA	C CHIP CERA	Y5V 50V 0.068MF Z 2012	
CC252	HCBK153KCA	C CHIP CERA	X7R 50V 0.015MF K 2012	
CC253	HCFK104ZCA	C CHIP CERA	Y5V 50V 0.1MF Z 2012	
CC254	HCFK103ZCA	C CHIP CERA	Y5V 50V 0.01MF Z 2012	
CC255	HCQK100DCA	C CHIP CERA	50V CH 10PF D 2012	
CC256	HCBK222KCA	C CHIP CERA	X7R 50V 2200PF K 2012	
CC257	HCFK104ZCA	C CHIP CERA	Y5V 50V 0.1MF Z 2012	
CC302	HCBK222KCA	C CHIP CERA	X7R 50V 2200PF K 2012	
CC304	HCBK102KCA	C CHIP CERA	X7R 50V 1000PF K 2012	
CC401	HCBK222KCA	C CHIP CERA	X7R 50V 2200PF K 2012	
CC501	HCFK104ZCA	C CHIP CERA	Y5V 50V 0.1MF Z 2012	
CC502	HCQK181JCA	C CHIP CERA	50V CH 180PF J 2012	
CC503	HCBK472KCA	C CHIP CERA	X7R 50V 4700PF K 2012	
CC504	HCQK160JCA	C CHIP CERA	CH 50V 16PF J 2012	
CC505	HCQK180JCA	C CHIP CERA	50V CH 18PF J 2012	
CC510	HCFK103ZCA	C CHIP CERA	Y5V 50V 0.01MF Z 2012	
CC665	HCFK103ZCA	C CHIP CERA	Y5V 50V 0.01MF Z 2012	
CC666	HCFK103ZCA	C CHIP CERA	Y5V 50V 0.01MF Z 2012	
CC667	HCFK103ZCA	C CHIP CERA	Y5V 50V 0.01MF Z 2012	
CC668	HCFK103ZCA	C CHIP CERA	Y5V 50V 0.01MF Z 2012	
CC669	HCFK103ZCA	C CHIP CERA	Y5V 50V 0.01MF Z 2012	
CC701	HCQK150JCA	C CHIP CERA	CH50V 15PF J 2012	
CC702	HCQK150JCA	C CHIP CERA	CH 50V 15PF J 2012	
CC703	HCFX104ZCA	C CHIP CERA	Y5V 50V 0.1MF Z 2012	

LOC.	PART-CODE	PART-NAME	PART-DESCRIPTION	REMARK
CC704	HCQK220JCA	C CHIP CERA	50V CH 22PF J 2012	
CC705	HCFK104ZCA	C CHIP CERA	Y5V 50V 0.1MF Z 2012	
CC706	HCQK220JCA	C CHIP CERA	50V CH 22PF J 2012	
CC707	HCQK271JCA	C CHIP CERA	50V CH 270PF J 2012	
CC708	HCQK271JCA	C CHIP CERA	50V CH 270PF J 2012	
CC709	HCFK103ZCA	C CHIP CERA	Y5V 50V 0.01MF Z 2012	
CC710	HCBK102KCA	C CHIP CERA	X7R 50V 1000PF K 2012	
CC711	HCBK102KCA	C CHIP CERA	X7R 50V 1000PF K 2012	
CC712	HCBK102KCA	C CHIP CERA	X7R 50V 1000PF K 2012	
CC713	HCBK102KCA	C CHIP CERA	X7R 50V 1000PF K 2012	
CC714	HCFK103ZCA	C CHIP CERA	Y5V 50V 0.01MF Z 2012	
CC750	HCBK102KCA	C CHIP CERA	X7R 50V 1000PF K 2012	
CC777	HCFK104ZCA	C CHIP CERA	Y5V 50V 0.1MF Z 2012	
CC801	HCQK101JCA	C CHIP CERA	50V CH 100PF J2012	
CC901	HCQK150JCA	C CHIP CERA	50V CH 15PF J 2012	
CC902	HCQK150JCA	C CHIP CERA	50V CH 15PF J 2012	
CC903	HCQK221JCA	C CHIP CERA	50V CH 220PF J 2012	
CC904	HCQK221JCA	C CHIP CERA	50V CH 220PF J 2012	
CC906	HCFK104ZCA	C CHIP CERA	Y5V 50V 0.1MF Z 2012	
CC907	HCQK271JCA	C CHIP CERA	50V CH 270PF J 2012	
CC908	HCFK103ZCA	C CHIP CERA	Y5V 50V 0.1MF Z 2012	
CC909	HCFK103ZCA	C CHIP CERA	Y5V 50V 0.1MF Z 2012	
JC02	HRFT000-CA	R CHIP	1/10 0 OHM 2012	
JC03	HRFT000-CA	R CHIP	1/10 0 OHM 2012	
JC04	HRFT000-CA	R CHIP	1/10 0 OHM 2012	
JC05	HRFT000-CA	R CHIP	1/10 0 OHM 2012	
JC06	HRFT000-CA	R CHIP	1/10 0 OHM 2012	
JC08	HRFT000-CA	R CHIP	1/10 0 OHM 2012	
JC09	HRFT000-CA	R CHIP	1/10 0 OHM 2012	
JC10	HRFT000-CA	R CHIP	1/10 0 OHM 2012	
JC12	HRFT000-CA	R CHIP	1/10 0 OHM 2012	
JC15	HRFT000-CA	R CHIP	1/10 0 OHM 2012	
JC16	HRFT000-CA	R CHIP	1/10 0 OHM 2012	
JC19	HRFT000-CA	R CHIP	1/10 0 OHM 2012	
JC21	HRFT000-CA	R CHIP	1/10 0 OHM 2012	
JC30	HRFT000-CA	R CHIP	1/10 0 OHM 2012	
RC103	HRFT472JCA	R CHIP	1/10 4.7K OHM J 2012	
RC104	HRFT221JCA	R CHIP	1/10 220 OHM J 2012	
RC105	HRFT122JCA	R CHIP	1/10 1.2K OHM J 2012	
RC107	HRFT682JCA	R CHIP	1/10 6.8K OHM J 2012	
RC108	HRFT333JCA	R CHIP	1/10 33K OHM J 2012	
RC109	HRFT222JCA	R CHIP	1/10 2.2K OHM J 2012	
RC110	HRFT682JCA	R CHIP	1/10 6.8K OHM J 2012	
RC111	HRFT473JCA	R CHIP	1/10 47K OHM J 2012	
RC112	HRFT304JCA	R CHIP	1/10 300K OHM J 2012	

LOC.	PART-CODE	PART-NAME	PART-DESCRIPTION	REMARK
RC114	HRFT471JCA	R CHIP	1/10 470 OHM J 2012	
RC115	HRFT472JCA	R CHIP	1/10 4.7K OHM J 2012	
RC116	HRFT393JCA	R CHIP	1/10 39K OHM J 2012	
RC118	HRFT225JCA	R CHIP	1/10 2.2M OHM J	
RC120	HRFT101JCA	R CHIP	1/10 100 OHM J 2012	
RC121	HRFT183JCA	R CHIP	1/10 18K OHM J 2012	
RC123	HRFT122JCA	R CHIP	1/10 1.2K OHM J 2012	
RC124	HRFT391JCA	R CHIP	1/10 390 OHM J 2012	
RC159	HRFT472JCA	R CHIP	1/10 4.7K OHM J 1012	
RC162	HRFT102JCA	R CHIP	1/10 1K OHM J 2012	
RC202	HRFT102JCA	R CHIP	1/10 1K OHM J 2012	
RC210	HRFT123JCA	R CHIP	1/10 12K OHM J 2012	
RC212	HRFT102JCA	R CHIP	1/10 1K OHM J 2012	
RC240	HRFT102JCA	R CHIP	1/10 1K OHM J 2012	
RC250	HRFT123JCA	R CHIP	1/10 12K OHM J 2012	
RC251	HRFT754JCA	R CHIP	1/10 750K OHM J 2012	
RC252	HRFT102JCA	R CHIP	1/10 1K OHM J 2012	
RC253	HRFT103JCA	R CHIP	1/10 10K OHM J 2012	
RC260	HRFT472JCA	R CHIP	1/10 4.7K OHM J 2012	
RC261	HRFT223JCA	R CHIP	1/10 22K OHM J 2012	
RC262	HRFT333JCA	R CHIP	1/10 33K OHM J2012	
RC263	HRFT103JCA	R CHIP	1/10 10K OHM J 2012	
RC264	HRFT472JCA	R CHIP	1/10 4.7K OHM J 2012	
RC265	HRFT223JCA	R CHIP	1/10 22K OHM J 2012	
RC267	HRFT103JCA	R CHIP	1/10 10K OHM J 2012	
RC268	HRFT224JCA	R CHIP	1/10 220K OHM J 2012	
RC274	HRFT472JCA	R CHIP	1/10 4.7K OHM J 2012	
RC301	HRFT562JCA	R CHIP	1/10 5.6K OHM J 2012	
RC303	HRFT752JCA	R CHIP	1/10 7.5K OHM J 2012	
RC304	HRFT153JCA	R CHIP	1/10 15K OHM J 2012	
RC308	HRFT821JCA	R CHIP	1/10 820 OHM J 2012	
RC401	HRFT153JCA	R CHIP	1/10 15K OHM J 2012	
RC403	HRFT103JCA	R CHIP	1/10 10K OHM J 2012	
RC405	HRFT472JCA	R CHIP	1/10 4.7K OHM J 2012	
RC473	HRFT750JCA	R CHIP	1/10 75 OHM J 2012	
RC501	HRFT104JCA	R CHIP	1/10 100K OHM J 2012	
RC502	HRFT753JCA	R CHIP	1/10 75K OHM J 2012	
RC568	HRFT303JCA	R CHIP	1/10 30K OHM J 2012	
RC601	HRFT829JCA	R CHIP	1/10 8.2 OHM J 2012	
RC602	HRFT829JCA	R CHIP	1/10 8.2 OHM J 2012	
RC603	HRFT222JCA	R CHIP	1/10 2.2K OHM J 2012	
RC604	HRFT181JCA	R CHIP	1/10 180 OHM J 2012	
RC605	HRFT181JCA	R CHIP	1/10 180 OHM J 2012	
RC606	HRFT222JCA	R CHIP	1/10 2.2K OHM J 2012	

LOC.	PART-CODE	PART-NAME	PART-DESCRIPTION	REMARK
RC607	HRFT222JCA	R CHIP	1/10 2.2K OHM J 2012	
RC608	HRFT829JCA	R CHIP	1/10 8.2 OHM J 2012	
RC609	HRFT829JCA	R CHIP	1/10 8.2 OHM J 2012	
RC610	HRFT181JCA	R CHIP	1/10 180 OHM J 2012	
RC611	HRFT181JCA	R CHIP	1/10 180 OHM J 2012	
RC612	HRFT222JCA	R CHIP	1/10 2.2K OHM J 2012	
RC668	HRFT750JCA	R CHIP	1/10 75 OHM J 2012	
RC669	HRFT750JCA	R CHIP	1/10 75 OHM J 2012	
RC670	HRFT750JCA	R CHIP	1/10 180 OHM J 2012	
RC671	HRFT472JCA	R CHIP	1/10 4.7K OHM J 2012	
RC672	HRFT472JCA	R CHIP	1/10 4.7K OHM J 2012	
RC701	HRFT223JCA	R CHIP	1/10 22K OHM J 2012	
RC702	HRFT912JCA	R CHIP	1/10 9.1K OHM J 2012	
RC703	HRFT333JCA	R CHIP	1/10 33K OHM J 2012	
RC704	HRFT333JCA	R CHIP	1/10 33K OHM J 2012	
RC705	HRFT201JCA	R CHIP	1/10 200 OHM J 2012	
RC706	HRFT472JCA	R CHIP	1/10 4.7K OHM J 2012	
RC708	HRFT392JCA	R CHIP	1/10 3.9K OHM J 2012	
RC709	HRFT152JCA	R CHIP	1/10 1.5K OHM J 2012	
RC710	HRFT473JCA	R CHIP	1/10 47K OHM J 2012	
RC711	HRFT223JCA	R CHIP	1/10 22K OHM J 2012	
RC712	HRFT473JCA	R CHIP	1/10 47K OHM J 2012	
RC713	HRFT472JCA	R CHIP	1/10 4.7K OHM J 2012	
RC714	HRFT183JCA	R CHIP	1/10 18K OHM J 2012	
RC715	HRFT103JCA	R CHIP	1/10 10K OHM J 2012	
RC717	HRFT103JCA	R CHIP	1/10 10K OHM J 2012	
RC718	HRFT332JCA	R CHIP	1/10 3.3K OHM J 2012	
RC719	HRFT101JCA	R CHIP	1/10 100 OHM J 2012	
RC720	HRFT101JCA	R CHIP	1/10 100 OHM J 2012	
RC721	HRFT332JCA	R CHIP	1/10 3.3K OHM J 2012	
RC722	HRFT101JCA	R CHIP	1/10 100 OHM J 2012	
RC723	HRFT101JCA	R CHIP	1/10 100 OHM J 2012	
RC724	HRFT102JCA	R CHIP	1/10 1K OHM J 2012	
RC725	HRFT103JCA	R CHIP	1/10 10K OHM J 2012	
RC726	HRFT102JCA	R CHIP	1/10 1K OHM J 2012	
RC727	HRFT114JCA	R CHIP	1/10 110K OHM J 2012	
RC728	HRFT823JCA	R CHIP	1/10 82K OHM J 2012	
RC729	HRFT101JCA	R CHIP	1/10 100 OHM J 2012	
RC734	HRFT102JCA	R CHIP	1/10 1K OHM J 2012	
RC741	HRFT473JCA	R CHIP	1/10 47K OHM J 2012	
RC742	HRFT473JCA	R CHIP	1/10 47K OHM J 2012	
RC744	HRFT473JCA	R CHIP	1/10 47K OHM J 2012	
RC745	HRFT473JCA	R CHIP	1/10 47K OHM J 2012	
RC746	HRFT750JCA	R CHIP	1/10 75 OHM J 2012	

LOC.	PART-CODE	PART-NAME	PART-DESCRIPTION	REMARK
RC748	HRFT472JCA	R CHIP	1/10 4.7K OHM J 2012	
RC749	HRFT473JCA	R CHIP	1/10 47K OHM J 2012	
RC751	HRFT472JCA	R CHIP	1/10 4.7K OHM J 2012	
RC752	HRFT103JCA	R CHIP	1/10 10K OHM J 2012	
RC753	HRFT103JCA	R CHIP	1/10 10K OHM J 2012	
RC754	HRFT103JCA	R CHIP	1/10 10K OHM J 2012	
RC755	HRFT103JCA	R CHIP	1/10 10K OHM J 2012	
RC756	HRFT103JCA	R CHIP	1/10 10K OHM J 2012	
RC757	HRFT103JCA	R CHIP	1/10 10K OHM J 2012	
RC758	HRFT103JCA	R CHIP	1/10 10K OHM J 2012	
RC759	HRFT103JCA	R CHIP	1/10 10K OHM J 2012	
RC761	HRFT132JCA	R CHIP	1/10 1.3K OHM J 2012	
RC762	HRFT473JCA	R CHIP	1/10 47K OHM J 2012	
RC763	HRFT104JCA	R CHIP	1/10 100K OHM J 2012	
RC764	HRFT472JCA	R CHIP	1/10 4.7K OHM J 2012	
RC765	HRFT103JCA	R CHIP	1/10 10K OHM J 2012	
RC771	HRFT472JCA	R CHIP	1/10 4.7K OHM J 2012	
RC772	HRFT561JCA	R CHIP	1/10 560 OHM J 2012	
RC773	HRFT472JCA	R CHIP	1/10 4.7K OHM J 2012	
RC775	HRFT681JCA	R CHIP	1/10 680 OHM J 2012	
RC777	HRFT102JCA	R CHIP	1/10 1K OHM J 2012	
RC780	HRFT750JCA	R CHIP	1/10 75 OHM J 2012	
RC801	HRFT563JCA	R CHIP	1/10 56K OHM J 2012	
RC802	HRFT102JCA	R CHIP	1/10 1K OHM J 2012	
RC803	HRFT104JCA	R CHIP	1/10 100K OHM J 2012	
RC804	HRFT102JCA	R CHIP	1/10 1K OHM J 2012	
RC806	HRFT102JCA	R CHIP	1/10 1K OHM J 2012	
RC901	HRFT103JCA	R CHIP	1/10 10K OHM J 2012	
RC902	HRFT102JCA	R CHIP	1/10 1K OHM J 2012	
RC903	HRFT123JCA	R CHIP	1/10 12K OHM J 2012	
RC904	HRFT750JCA	R CHIP	1/10 75 OHM J 2012	
RC906	HRFT750JCA	R CHIP	1/10 75 OHM J 2012	
RC907	HRFT750JCA	R CHIP	1/10 75 OHM J 2012	
RC908	HRFT750JCA	R CHIP	1/10 75 OHM J 2012	

■ PCB MAIN RADIAL AS

C101	CEXF1H470V	C ELECTRO	50V RSS 47MF (6.3X11)	
C102	CEXE1H100A	C ELELCTRO	50V RS 10MF (5X11)	
C103	CEXE1H100A	C ELECTRO	50V RS 10MF (5X11)	
C104	CMXM2A104J	C MYLAR	100V 0.1MF J (TAPPING)	
C105	CEXF1E101V	C ELECTRO	25V RSS 100MF (6.3X11)	TU
	CEXF1E100V	C ELECTRO	25V RSS 10MF	TF,TS,TK,VA
C106	CEXF1H330V	C ELECTRO	RSS 50V 33MF (6.3X11)	
C107	CEXE1H229A	C ELECTRO	50V RS 2.2MF (5X11)	

LOC.	PART-CODE	PART-NAME	PART-DESCRIPTION	REMARK
C108	CEXE1H109A	C ELECTRO	50V RS 1MF (5X11)	
C109	CEXE1M109A	C ELECTRO	50V RS 1MF (5X11)	
C110	CCXB1H102K	C CERA	50V B 1000PF K (TAPPING)	
C121	CMXM2A473J	C MYLAR	100V 0.047MF J (TAPPING)	
C138	CCXF1H103Z	C CERA	50V F 0.01MF Z (TAPPING)	
C150	CXCH1H100F	C CERA	50V CH 10PF D (TAPPING)	
C204	CEXE1H109A	C ELECTRO	50V RS 1MF (5X11)	
C205	CEXE1H479A	C ELECTRO	50V RS 4.7MF (5X11)	
C206	CEXE1H100A	C ELECTRO	50V RS 10MF (5X11)	
C207	CMXM2A104J	C MYLAR	100V 0.1MF J (TAPPING)	
C208	CMXM2A104J	C MYLAR	100V 0.1MF J (TAPPING)	
C209	CMXM2A104J	C MYLAR	100V 0.1MF J (TAPPING)	
C250	CEXE1H479A	C ELECTRO	50V RS 4.7MF (5X11)	
C251	CMXM2A104J	C MYLAR	100V 0.1MF J (TAPPING)	
C301	CMXM2A472J	C MYLAR	100V 4700PF J (TAPPING)	
C302	CCXB1H821K	C CERA	50V B 820PF K (TAPPING)	
C305	CCXB2H152K	C CERA	500V B 1500PF K (TAPPING)	
C306	CEXE1H100A	C ELECTRO	50V RS 10MF (5X11)	
C308	CMXM2A683J	C MYLAR	100V 0.068MF J (TAPPING)	
C309	CCXB2M102K	C CERA	500V B 1000PF K (TAPPING)	
C401	CEXE1M109A	C ELECTRO	50V RS 1MF (5X11)	
C403	CXSL2H1000	C CERA	500V SL 10PF D (TAPPING)	
C404	CCXB2H471K	C CERA	500V B 470PF K (TAPPING)	
C406	CCXE2H472P	C CERA	500V E 4700PF P (TAPPING)	
C415	CCXB2H102K	C CERA	500V B 1000PF K (TAPPING)	
C417	CCX82H101K	C CERA	50V B 100PF K (TAPPING)	
C418	CEXE2C109C	C ELECTRO	160V RU 1MF (8X11.5)	
C503	CMXM2A104J	C MYLAR	100V 0.1MF J (TAPPING)	
C504	CMXM2A104J	C MYLAR	100V 0.1MF J (TAPPING)	
C505	CMXM2A104J	C MYLAR	100V 0.1MF J (TAPPING)	
C 506	CCXB1H102K	C CERA	50V B 1000PF K (TAPPING)	
C507	CCXB1H102K	C CERA	50V B 1000PF K (TAPPING)	
C508	CEXF1H220V	C ELECTRO	50V RSS 22MF (5X11) TP	
C510	CEXF1H470V	C ELECTRO	50V RSS 47MF (6.3X11)	
C511	CCXB1H472K	C CERA	50V B 4700PF K (TAPPING)	
C512	CEXF1H470V	C ELECTRO	50V RSS 47MF (6.3X11)	
C513	CMXM2A104J	C MYLAR	100V 0.1MF J (TAPPING)	
C 601	CMXM2A104J	C MYLAR	100V 0.1 MF J (TAPPING)	
C602	CMXM2A104J	C MYLAR	100V 0.1MF J (TAPPING)	
C603	CEXF1H470V	C ELECTRO	50V RSS 47MF (6.3X11)	
C604	CEXF1H101V	C ELECTRO	25V RSS 100MF (6.3X11)	
C605	CEXF1H470V	C ELECTRO	50V RSS 47MF (6.3X11)	
C608	CMXM2A104J	C MYLAR	100V 0.1MF J (TAPPING)	
C609	CMXM2A104J	C MYLAR	100V 0.1MF J (TAPPING)	
C651	CCXB1M102K	C MYLAR	50V B 1000PF K (TAPPING)	

LOC.	PART-CODE	PART-NAME	PART-DESCRIPTION	REMARK
C652	CCXB1M102K	C MYLAR	50V B 1000PF K (TAPPING)	
C670	CMXM2A223J	C MYLAR	100V 0.022MF J (TAPPING)	
C671	CMXM2A223J	C MYLAR	100V 0.022MF J (TAPPING)	
C701	CCXB1M221K	C MYLAR	50V B 220PF K (TAPPING)	
C702	CMXM2A104J	C MYLAR	100V 0.1MF J (TAPPING)	
C703	CMXM2A104J	C MYLAR	100V 0.1MF J (TAPPING)	
C704	CEXE1H479A	C ELECTRO	50V RS 4.7MF (5X11)	
C705	CEXE1H479A	C ELECTRO	50V RS 4.7 MF (5X11)	
C710	CEXE1H100A	C ELECTRO	50V RS 10MF (5X11)	
C711	CEXF1H470V	C ELECTRO	50V RSS 47MF (6.3X11)	
C713	CEXE1H479A	C ELECTRO	50V RS 4.7MF (5X11)	
C714	CEXE1H479A	C ELECTRO	50V RS 4.7MF (5X11)	
C718	CEXE1H479A	C ELECTRO	50V RS 4.7MF (5X11)	
C720	CEXE1H479A	C ELECTRO	50V RS 4.7MF (5X11)	
C721	CEXE1H479A	C ELECTRO	50V RS 4.7MF (5X11)	
C722	CEXE1H479A	C ELECTRO	50V RS 4.7MF (5X11)	
C726	CEXE1H479A	C ELECTRO	50V RS 4.7MF (5X11)	
C727	CEXE1H479A	C ELECTRO	50V RS 4.7MF (5X11)	
C728	CEXE1H479A	C ELECTRO	50V RS 4.7MF (5X11)	
C729	CEXE1H479A	C ELECTRO	50V RS 4.7MF (5X11)	
C731	CEXE1H479A	C ELECTRO	50V RS 4.7MF (5X11)	
C732	CEXE1H479A	C ELECTRO	50V RS 4.7MF (5X11)	
C733	CEXE1H479A	C ELECTRO	50V RS 4.7MF (5X11)	
C734	CEXE1H479A	C ELECTRO	50V RS 4.7MF (5X11)	
C736	CEXE1H479A	C ELECTRO	50V RS 4.7MF (5X11)	
C737	CEXE1H220A	C ELECTRO	50V RSS 22MF (5X11)	
C740	CEXDIC220F	C ELECTRO	16V RND 220μF	
C776	CEXE1H100A	C ELECTRO	50V RS 10MF (5X11)	
C777	CEXFIC 470V	C ELECTRO	16V RSS 47MF	
C779	CEXD1H109F	C ELECTRO	50V RND 1MF (5X11)	
C780	CCXF1H103Z	C CERA	50V F 0.01MF Z (TAPING)	
C789	CMXM2A104J	C MYLAR	100V 0.1MF J (TAPPING)	
C811	CEXF1H101V	C ELECTRO	50V RSS 100MF (8X11.5)	
C812	CEXE1H109A	C ELECTRO	50V RS 1MF (5X11)	
C813	CEXF1H101V	C ELECTRO	50V RSS 100MF (8X11.5)	
C814	CMXM2A562J	C MYLAR	100V 5600PF J (TAPPING)	
C817	CEXF1H101V	C ELECTRO	50V RSS 100MF (8X11.5)	
C821	CCXB2H102K	C CERA	500V B 1000PF K (TAPPING)	
C834	CEXF1C101V	C ELECTRO	16V RSS 100MF (6.3X11)	
C835	CEXE1H100A	C ELECTRO	50V RS 10MF (5X11)	
C840	CBXF1H104Z	C CERA SEMI	50V F 0.1MF Z (TAPPING)	
C903	CEXE1H109A	C ELECTRO	50V RS 1MF (5X11)	
F801A	4857415001	CLIP FUSE	PFC5000-0702	
F801B	4857415001	CLIP FUSE	PFC5000-0702	
L201	5CPX829K--	COIL PEAKING	8.2UH K RADIAL	

LOC.	PART-CODE	PART-NAME	PART-DESCRIPTION	REMARK
L701	5CPX390K--	COIL PEAKING	39UH K RADIAL	
L804	5CPX109K--	COIL PEAKING	PL 1 UH K (TAPPING)	
Q101	TKTC3198Y-	TR	KTC3198Y	
Q113	TKTC3198Y-	TR	XTC3198Y	
Q116	TKTC3198Y-	TR	KTC3198Y	
Q117	TKTC3198Y-	TR	KTC3198Y	
Q118	TKTA1226Y-	TR	KTA1266Y	
Q202	TKTC3198Y-	TR	KTC3198Y	
Q203	TKTC3198Y-	TR	KTC3198Y	
Q204	TKTC3198Y-	TR	KTC3198Y	
Q205	TKTC3198Y-	TR	KTC3198Y	
Q210	TKTA1226Y-	TR	KTA1266Y	
Q211	TKTA1266Y-	TR	KTA1266Y	
Q212	TKTA1266Y-	TR	KTA1266Y	
Q221	TKTC3198Y-	TR	KTC3198Y	
Q250	TKTC3198Y-	TR	KTC3198Y	
Q401	TKTC3198Y-	TR	KTC3198Y	
Q402	TKTC3207--	TR	KTC3207	
Q601	TKTC3198Y-	TR	KTC3198Y	
Q610	TKTC3198Y-	TR	KTC3198Y	
Q701	TKTC3202Y-	TR	KTC3202Y	
Q702	TKTC3202Y-	TR	KTC3202Y	
Q703	TKTC3198Y-	TR	KTC3198Y	
Q704	TKTC3198Y-	TR	KTC3198Y	
Q705	TKTA1277Y-	TR	KTA1277Y	
Q706	TKTC3198Y-	TR	KTC3198Y	
Q707	TKTC3198Y-	TR	KTC3198Y	
Q709	TKTA1266Y-	TR	KTA1266Y	
Q710	TKTC3198Y-	TR	KTC3198Y	
Q711	TKTC3198Y-	TR	KTC3198Y	
Q712	TKTC3198Y-	TR	KTC3198Y	
Q803	TKTC3198Y-	TR	KTC3198Y	
Q804	TKTC3198Y-	TR	KTC3198Y	
Q805	TKTA1266Y-	TR	KTA1266Y	
Q806	TKTC3198Y-	TR	KTC3198Y	
VR101	RV5426103P	R SEMI FIXED	RM0638C 10K OHM B	
VR201	RV5426103P	R SEMI FIXED	RH0638C 10K OHM B	
VR301	RV5426103P	R SEMI FIXED	RH0638C 10K OHM B	
VR302	RV5426473P	R SEMI FIXED	RH0638C 47K OHM B	
VR401	RV5426103P	R SEMI FIXED	RH0638C 10K OHM B	
VR801	RV5426472P	R SEMI FIXED	RH0638C 10K OHM B	

LOC.	PART-CODE	PART-NAME	PART-DESCRIPTION	REMARK
------	-----------	-----------	------------------	--------

■ PCB MAIN AXIAL AS

A001	4859809592	PCB MAIN	T1.6X330X246	
D101	D1N4148---	DIODE	1N4148	
D102	D1N4148---	DIODE	1N4148	
D201	D1N4148---	DIODE	1N4148	
D203	D1N4148---	DIODE	1N4148	
D204	D1N4148---	DIODE	1N4148	
D205	D1N4148---	DIODE	1N4148	
D209	D1N4148---	DIODE	1N4148	
D250	D1N4148---	DIODE	1N4148	
D252	DZPD09R1---	DIODE ZENER	ZPD 9.1	
D301	DZPD5R1---	DIODE ZENER	ZPD5.1	
D302	DBYV95C---	DIODE	BYV95C	
D303	DBYV95C---	DIODE	BYV95C	
D401	DZPD8R2---	DIODE ZENER	ZPD8.2	
D402	DBYV95C---	DIODE	BYV95C	
D404	DBYV95C---	DIODE	BYV95C	
D405	DBYV95C---	DIODE	BYV95C	
D406	DZPD5R1---	DIODE ZENER	ZPD5.1	
D407	D1N4148---	DIODE	1N4148	
D468	D1N4148---	DIODE	1N4148	
D506	DZPD5R6---	DIODE ZENER	ZPD 5.6	
D561	DZPD6R2---	DIODE ZENER	ZPD6.2	
D562	DZPD6R2---	DIODE ZENER	ZPD6.2	
D651	DZPD6R2---	DIODE ZENER	ZPD6.2	
D652	DZPD6R2---	DIODE ZENER	ZPD6.2	
D653	DZPD6R2---	DIODE ZENER	ZPD6.2	
D654	DZPD6R2---	DIODE ZENER	ZPD6.2	
D655	DZPD6R2---	DIODE ZENER	ZPD6.2	
D656	DZPD6R2---	DIODE ZENER	ZPD6.2	
D657	DZPD6R2---	DIODE ZENER	ZPD6.2	
D658	DZPD6R2---	DIODE ZENER	ZPD6.2	
D659	DZPD6R2---	DIODE ZENER	ZPD6.2	
D660	DZPD6R2---	DIODE ZENER	ZPD6.2	
D661	DZPD6R2---	DIODE ZENER	ZPD6.2	
D662	DZPD6R2---	DIODE ZENER	ZPD6.2	
D663	DZPD6R2---	DIODE ZENER	ZPD6.2	
D664	DZPD6R2---	DIODE ZENER	ZPD6.2	
D704	D1N4148---	DIODE	1N4148	
D705	D1N4148---	DIODE	1N4148	
D708	D1N4148---	DIODE	1N4148	
D710	DZPD6R2---	DIODE ZENER	ZPD6.2	
D711	D1N4148---	DIODE	1N4148	
D712	DZPD12----	DIODE ZENER	ZPD12	

LOC.	PART-CODE	PART-NAME	PART-DESCRIPTION	REMARK
D714	D1N4148---	DIODE	1N4148	
D727	D1N4148---	DIODE	1N4148	
D728	DZPD6R2---	DIODE ZENER	ZPD6.2	
D729	DZPD13----	DIODE ZENER	ZPD-13	
D730	DZPD6R2---	DIODE ZENER	ZPD6.2	
D731	DZPD6R2---	DIODE ZENER	ZPD6.2	
D732	DZPD6R2---	DIODE ZENER	ZPD6.2	
D733	DZPD6R2---	DIODE ZENER	ZPD6.2	
D734	DZPD6R2---	DIODE ZENER	ZPD6.2	
D738	D1N4148---	DIODE	1N4148	VA
D741	D1N4148---	DIODE	1N4148	TU
D744	D1N4148---	DIODE	1N4148	AV2
D746	D1N4148---	DIODE	1N4148	TU,TS
D748	D1N4148---	DIODE	1N4148	TU
D750	D1N4148---	DIODE	1N4148	TK
D802	DBYV95C---	DIODE	BYV95C	
D804	DBYV95C---	DIODE	BYV95C	
D805	DBYV95C---	DIODE	BYV95C	
D806	DBYV95C---	DIODE	BYV95C	
D807	DBYV95C---	DIODE	BYV95C	
D810	DBYV95C---	DIODE	BYV95C	
D811	D1N4148---	DIODE	1N4148	
D812	D1N4148---	DIODE	1N4148	
D813	D1N4148---	DIODE	1N4148	
D901	DZPD6R2---	DIODE ZENER	ZPD6.2	
JW01		WIRE JUMPER		TK
J233	85801065GY	WIRE COPPER	AWG22 1/0.65 TIN COATING	VA
J234	85801065GY	WIRE COPPER	AWG22 1/0.65 TIN COATING	VA
J256	85801065GY	WIRE COPPER	AWG22 1/0.65 TIN COATING	TF, TK, VA
J282	85801065GY	WIRE COPPER	AWG22 1/0.65 TIN COATING	TS, TU
L301	58C100J091	COIL CHOKE	AL04-100JJ (10MH)	
L302	58C100J091	COIL CHOKE	AL04-100JJ (10MH)	
L651	58C100J091	COIL CHOKE	AL04-100JJ (10MH)	
L652	58C100J091	COIL CHOKE	AL04-100JJ (10MH)	
L653	58C100J091	COIL CHOKE	AL04-100JJ (10MH)	
L654	58C100J091	COIL CHOKE	AL04-100JJ (10MH)	
L655	58C100J091	COIL CHOKE	AL04-100JJ (10MH)	
L656	58C100J091	COIL CHOKE	AL04-100JJ (10MH)	
L702	5CPZ100K02	COIL PEAKING	10UH 3.5MM K (L AL02TB)	
L703	5CPZ100K02	COIL PEAKING	10UH 3.5MM K (L AL02TB)	
L704	5CPZ100K02	COIL PEAKING	10UH 3.5MM K (L AL02TB)	
L705	5CPZ100K02	COIL PEAKING	100UH 3.5MM K (L AL02TB)	
R101	RD-4Z335J-	R CARBON FILM	1/4 3.3M OHM J	
R110	RD-4Z225J-	R CARBON FILM	1/4 2.2M OHM J	
R111	RD-AZ820J-	R CARBON FILM	1/6 82 OHM J	
R147	RD-4Z820J-	R CARBON FILM	1/4 82 OMH J	

LOC.	PART-CODE	PART-NAME	PART-DESCRIPTION	REMARK
R211	RD-AZ472J-	R CARBON FILM	1/6 4.7K OHM J	
R212	RD-4Z472J-	R CARBON FILM	1/4 4.7K OHM J	
R213	RD-4Z122J-	R CARBON FILM	1/4 1.2K OHM J	
R215	RD-4Z470J-	R CARBON FILM	1/4 47 OHM J	
R216	RD-AZ162J-	R CARBON FILM	1/6 1.6K OHM J	
R217	RD-AZ162J-	R CARBON FILM	1/6 1.6K OHM J	
R218	RD-AZ331J-	R CARBON FILM	1/6 330 OHM J	
R220	RD-AZ103J-	R CARBON FILM	1/6 10K OHM J	
R221	RD-4Z562J-	R CARBON FILM	1/6 5.6K OHM J	
R301	RD-4Z104J-	R CARBON FILM	1/4 100K OHM J	
R302	RD-2Z271J-	R CARBON FILM	1/2 270 OHM J	
R303	RD-4Z472J-	R CARBON FILM	1/4 4.7K OHM J	
R304	RD-AZ514J-	R CARBON FILM	1/6 510K OHM J	
R305	RD-2Z272J-	R CARBON FILM	1/2 2.7K OHM J	
R306	RD-2Z129J-	R CARBON FILM	1/2 1.2 OHM J	
R308	RD-4Z912J-	R CARBON FILM	1/4 9.1K OHM J	
R309	RD-4Z103J-	R CARBON FILM	1/4 10K OHM J	
R310	RD-4Z271J-	R CARBON FILM	1/4 270 OHM J	
R311	RD-4Z335J-	R CARBON FILM	1/4 3.3M OHM J	
R312	RD-AZ473J-	R CARBON FILM	1/6 47K OHM J	
R403	RD-4Z272J-	R CARBON FILM	1/4 2.7K OHM J	
R407	RD-2Z103J-	R CARBON FILM	1/2 10K OHM J	
R408	RD-2Z124J-	R CARBON FILM	1/2 120K OHM J	
R409	RD-4Z102J-	R CARBON FILM	1/4 1K OHM J	
R415	RD-2Z273J-	R CARBON FILM	1/2 27K OHM J	
R416	RD-4Z124J-	R CARBON FILM	1/4 120K OHM J	
R418	RD-4Z303J-	R CARBON FILM	1/4 30K OHM J	
R451	RD-4Z104J-	R CARBON FILM	1/4 100K OHM J	
R452	RD-AZ103J-	R CARBON FILM	1/6 10K OHM J	
R453	RD-4Z122J-	R CARBON FILM	1/4 1.2K OHM J	
R454	RD-4Z151J-	R CARBON FILM	1/4 150 OHM J	
R455	RD-AZ824J-	R CARBON FILM	1/6 820K OHM J	
R504	RD-4Z121J-	R CARBON FILM	1/4 120 OHM J	
R553	RD-4Z101J-	R CARBON FILM	1/4 100 OHM J	
R555	RD-AZ202J-	R CARBON FILM	1/6 2K OHM J	
R556	RD-AZ202J-	R CARBON FILM	1/6 2K OHM J	
R557	RD-AZ202J-	R CARBON FILM	1/6 2K OHM J	
R701	RD-4Z333J-	R CARBON FILM	1/4 33K OHM J	
R702	RD-AZ333J-	R CARBON FILM	1/6 33K OHM J	
R704	RD-AZ153J-	R CARBON FILM	1/6 15K OHM J	
R705	RD-AZ102J-	R CARBON FILM	1/6 1K OHM J	
R706	RD-4Z335J-	R CARBON FILM	1/4 3.3M OHM J	
R707	RD-4Z101J-	R CARBON FILM	1/4 100 OHM J	
R708	RD-4Z472J-	R CARBON FILM	1/4 4.7K OHM J	
R709	RD-4Z101J-	R CARBON FILM	1/4 100 OHM J	

LOC.	PART-CODE	PART-NAME	PART-DESCRIPTION	REMARK
R710	RD-4Z472J-	R CARBON FILM	1/4 4.7K OHM J	
R712	RD-4Z472J-	R CARBON FILM	1/4 4.7K OHM J	
R713	RD-4Z102J-	R CARBON FILM	1/4 1K OHM J	
R714	RD-4Z474J-	R CARBON FILM	1/4 470K OHM J	
R715	RD-4Z474J-	R CARBON FILM	1/4 470K OHM J	
R716	RD-AZ331J-	R CARBON FILM	1/6 330 OHM J	
R720	RD-4Z470J-	R CARBON FILM	1/4 47 OHM J	
R731	RD-AZ472J-	R CARBON FILM	1/6 4.7K OHM J	
R732	RD-4Z472J-	R CARBON FILM	1/4 4.7K OHM J	
R733	RD-AZ331J-	R CARBON FILM	1/6 330 OHM J	
R734	RD-AZ620J-	R CARBON FILM	1/6 62 OHM J	
R735	RD-4Z102J-	R CARBON FILM	1/4 1K OHM J	
R736	RD-4Z470J-	R CARBON FILM	1/4 47 OHM J	
R737	RD-4Z472J-	R CARBON FILM	1/4 4.7K OHM J	
R738	RD-4Z562J-	R CARBON FILM	1/4 5.6K OHM J	
R739	RD-AZ472J-	R CARBON FILM	1/6 4.7K OHM J	
R740	RD-AZ472J-	R CARBON FILM	1/6 4.7K OHM J	
R741	RD-AZ750J-	R CARBON FILM	1/6 75 OHM J	
R748	RD-AZ472J-	R CARBON FILM	1/6 4.7K OHM J	
R750	RD-AZ472J-	R CARBON FILM	1/6 4.7K OHM J	
R760	RD-AZ122J-	R CARBON FILM	1/6 1.2K OHM J	
R770	RD-4Z562J-	R CARBON FILM	1/4 5.6K OHM J	
R805	RD-4Z302J-	R CARBON FILM	1/4 3K OHM J	
R809	RD-4Z122J-	R CARBON FILM	1/4 1.2K OHM J	
R810	RD-4Z153J-	R CARBON FILM	1/4 15K OHM J	
R811	RD-4Z103J-	R CARBON FILM	1/4 10K OHM J	
R812	RD-4Z221J-	R CARBON FILM	1/4 220 OHM J	
R813	RD-2Z154J-	R CARBON FILM	1/2 150K OHM J	
R814	RD-2Z124J-	R CARBON FILM	1/2 120K OHM J	
R815	RD-2Z124J-	R CARBON FILM	1/2 120K OHM J	
R821	RD-4Z270J-	R CARBON FILM	1/4 27 OHM J	
R830	RD-AZ103J-	R CARBON FILM	1/6 10K OHM J	
R831	RD-AZ473J-	R CARBON FILM	1/6 47K OHM J	
R855	RD-2Z154J-	R CARBON FILM	1/2 150K OHM J	
R901	RD-4Z101J-	R CARBON FILM	1/4 100 OHM J	
R902	RD-4Z472J-	R CARBON FILM	1/4 4.7K OHM J	
R904	RD-4Z102J-	R CARBON FILM	1/4 1K OHM J	

■ PCB A/V MANUAL AS

30010	2193102005	SOLDER BAR	SN PB=63 47 S63S-1320	
30020	2193011101	SOLDER WIRE	RS 60-1.2 1.6A	
30030	2291050301	FLUX SOLVENT	1CAN/14KG H-302	
30040	2291050615	FLUX SOLDER	KS-892M-1	
30050	2291140501	WAX COVER		
30090	2291051001	FLUX KILLER	KFT-7	

LOC.	PART-CODE	PART-NAME	PART-DESCRIPTION	REMARK
HV01	4859105240	JACK PHONO	LGT1516-0100	
LV05	58C6R8J067	COIL CHOKE	TRF-1015C (6.8UH J)	
LV06	58C6R8J067	COIL CHOKE	TRF-1015C (6.8UH J)	
LV07	58C6R8J067	COIL CHOKE	TRF-1015C (6.8UH J)	
M231	4852317601	PANEL AV	MIPS BK	
M231A	7128301011	SCREW TAPPING	T2S WAS 3X10 MFZN	
M681	4856812001	TIE CABLE	NYLON66 DA100	
PV01	4859231620	CONN WAFER	YW025-03	
PV02	4859231620	CONN WAFER	YW025-03	
PV03A	4850704019	CONN AS	TH025-04+YST025+ULW=500	
PV04A	4850704035	CONN AS	YH025-04+YST025+ULW=500	
RV05A	4850706068	CONN AS	YH025-06+YST025+USW=500	TV,TS,VA,TK
PV05A	4860706069	CONN AS	YH025-06+YST025+USW=500	TF
SV01	4859101940	JACK S-VHS	YSC-SJ-1	
WV01	4859102250	JACK PIN BOARD	YSC03P-4120-115	

■ PCB AV RADIAL AS

CV01	CCXF1M103Z	C CERA	50V F 0.01MF Z (TAPPING)	
CV02	CCXF1M103Z	C CERA	50V F 0.01MF Z (TAPPING)	
CV03	CCXF1M103Z	C CERA	50V F 0.01MF Z (TAPPING)	
CV04	CCXF1M103Z	C CERA	50V F 0.01MF Z (TAPPING)	
CV05	CCXF1M103Z	C CERA	50V F 0.01MF Z (TAPPING)	
CV06	CCXF1M103Z	C CERA	50V F 0.01MF Z (TAPPING)	
CV07	CCXF1M103Z	C CERA	50V F 0.01MF Z (TAPPING)	
CV08	CCXF1M103Z	C CERA	50V F 0.01MF Z (TAPPING)	
CV09	CCXB1H102K	C CERA	50V B 100PF K (TAPPING)	
CV10	CCXF1M103Z	C CERA	50VF 0.01MF Z (TAPPING)	

■ PCB AV AXIAL AS

A001	4859837323	PCB AV JACK	T1.6X104X48(210X174/2X3)	
DV01	DZPD6R2---	DIODE ZENER	ZPD6.2	
DV02	DZPD6R2---	DIODE ZENER	ZPD6.2	
DV03	DZPD6R2---	DIODE ZENER	ZPD6.2	
DV04	DZPD6R2---	DIODE ZENER	ZPD6.2	
DV05	DZPD6R2---	DIODE ZENER	ZPD6.2	
LV02	58C100J091	COIL CHOKE	AL04-100J (100MH)	
LV03	58C100J091	COIL CHOKE	AL04-100J (100MH)	
LV04	58C100J091	COIL CHOKE	AL04-100J (100MH)	
RV01	RC-2Z101J-	R CARBON COMP	1/2 100 OHM J	
RV02	RC-2Z101J-	R CARBON COMP	1/2 100 OHM J	
RV05	RD-AZ473J-	R CARBON FILM	1/6 47K OHM J	
RV07	RD-AZ473J-	R CARBON FILM	1/6 47K OHM J	

LOC.	PART-CODE	PART-NAME	PART-DESCRIPTION	REMARK
------	-----------	-----------	------------------	--------

■ PCB NTCAM MANUAL AS

I101	1TDA4445B-	IC	TDA4445B	
I102	1MSP2410--	IC	MSP2410	
I103	1ACP2371N1	IC	ACP2371N1	
I104	1KA4558---	IC AMP	KA4558	
I105	1KA4558---	IC AMP	KA4558	
I106	1K1A7042P-	IC SWITCH	KIA7042P	
LA3	58M38R9006	COIL DET	TRF-1490	
LA5	5CPX470J--	COIL PEAKING	47UH J RADIAL	
LA8	5CPX479K--	COIL PEAKING	4.7HH K RADIAL	
M722	4857235500	SHIELD CASE	SPTH-C T0.5	
PA01	4859274520	CONN WAFER	YFAW025-120	
SAW1	5PJ9250M--	FILTER SAW	J9250M	
XA01	5XE18R432E	CRYSTAL QUARTZ	HC-49/U 18.43200 MHZ 30PPM	

■ PCB NICAM RADIAL AS

CA1	CMXM2A104J	C MYLAR	100V 0.1MF J (TAPPING)	
CA10	CXCH1H470J	C CERA	50V CH 47PF J (TAPPING)	
CA11	CEXF1H470V	C ELECTRO	50V RSS 47MF (6.3X11)	
CA12	CXCH1H680J	C CERA	50V CH 68PF J (TAPPING)	
CA13	CCXF1H103Z	C CERA	50V F 0.01MF Z (TAPPING)	
CA14	CEXF1H470V	C ELECTRO	50V RSS 47MF (6.3X11)	
CA17	CMXM2A103J	C MYLAR	100V 0.01MF J (TAPPING)	
CA18	CMXM2A104J	C MYLAR	100V 0.1MF J (TAPPING)	
CA19	CMXB1H332J	C MYLAR	EU 50V 3300PF J	
CA2	CEXE1H100A	C ELECTRO	50V RS 10MF (5X11)	
CA20	CCXB1H221K	C CERA	50V B 220PF K (TAPPING)	
CA22	CMXM2A104J	C MYLAR	100V 0.1MF J (TAPPING)	
CA23	CMXM2A104J	C MYLAR	100V 0.1MF J (TAPPING)	
CA24	CMXM2A104J	C MYLAR	100V 0.1MF J (TAPPING)	
CA27	CEXF1H330V	C ELECCTRO	RSS 50V 33MF 6.3X11	
CA29	CMXM2A103J	C MYLAR	100V 0.01MF J (TAPPING)	
CA3	CBXF1H104Z	C CERA SEMI	50V F 0.1MF Z (TAPPING)	
CA30	CEXE1H100A	C ELECTRO	50V RS 10MF (5X11)	
CA31	CCXF1H103Z	C CERA	50V F 0.01MF Z (TAPPING)	
CA32	CEXE1H100A	C ELECTRO	50V RS 10MF (5X11)	
CA33	CCXF1H103Z	C CERA	50V F 0.01MF Z (TAPPING)	
CA34	CMXM2A102J	C MYLAR	100V 1000PF J (TAPPING)	
CA35	CMXM2A102J	C MYLAR	100V 1000PF J (TAPPING)	
CA36	CEXF1H220V	C ELECTRO	50V RSS 22MF (5X11)	
CA37	CMXB1H222J	C MYLAR	EU 50V 2200PF J	
CA38	CEXF1H220V	C ELECCTRO	50V RSS 22MF (5X11)	
CA39	CMXB1H222J	C MYLAR	EU 50V 2200PF J	
CA4	CCXF1H103Z	C CERA	50V F 0.01MF Z (TAPPING)	

LOC.	PART-CODE	PART-NAME	PART-DESCRIPTION	REMARK
CA40	CEXF1H220V	C ELECTRO	50V RSS 22MF (5X11)	
CA41	CCXF1H103Z	C CERA	50V F 0.01MF Z (TAPPING)	
CA42	CEXD1H339F	C ELECTRO	50V RND 3.3MF (5X11)	
CA43	CEXE1H479A	C ELECTRO	50V RS 4.7MF (5X11)	
CA44	CEXE1H470V	C ELECTRO	50V RSS 47MF (6.3X11)	
CA45	CEXE1H470V	C ELECTRO	50V RSS 47MF (6.3X11)	
CA46	CMXM2A153J	C MYLAR	100V 0.015MF J (TAPPING)	
CA47	CMXM2A153J	C MYLAR	100V 0.015MF J (TAPPING)	
CA48	CCXB1H681K	C CERA	50V B 680PF K (TAPPING)	
CA49	CCX81H681K	C CERA	50V B 680 PF K (TAPPING)	
CA5	CEXE1H100A	C ELECTRO	50V RS 10MF (5X11)	
CA50	CCXB1H68AK	C CERA	50V B 680PF K (TAPPING)	
CA51	CEXE1H339A	C ELECTRO	50V RS 3.3MF (5X11)	
CA52	CMXM2A104J	C MYLAR	100V 0.1MF J (TAPPING)	
CA53	CCXF1H103Z	C CERA	50V F 0.01MF Z (TAPPING)	
CA54	CEXE1H109A	C ELECTRO	50V RS 1MF (5X11)	
CA55	CEXE1H109A	C ELECTRO	50V RS 1MF (5X11)	
CA57	CCXB1H182K	C CERA	50V B 1800PF K (TAPPING)	
CA58	CCXB1H102K	C CERA	50V 1000PF K (TAPPING)	
CA59	CCXB1H182K	C CERA	50V B 1800PF K (TAPPING)	
CA6	CMXM2A104J	C MYLAR	100V 0.1MF J (TAPPING)	
CA60	CCXB1H102K	C CERA	50V B 1000PF K (TAPPING)	
CA61	CCXB1H182K	C CERA	50V B 1800PF K (TAPPING)	
CA62	CCXB1H102K	C CERA	50V B 1000PF K (TAPPING)	
CA63	CCXB1H182K	C CERA	50V B 1800PF K (TAPPING)	
CA64	CCXB1H102K	C CERA	50V B 1000PF K (TAPPING)	
CA65	CEXE1H100A	C ELECTRO	50V RS 10MF (5X11)	
CA7	CXCH1H1000	C CERA	50V CH 10PF D (TAPPING)	
CA8	CXCH1H1000	C CERA	50V CH 10PF D (TAPPING)	
CA9	CXCH1H470J	C CERA	50V CH 47PF J (TAPPING)	
LA1	5CPX479K--	COIL PEAKING	4.7UH K RADIAL	
LA2	5CPX150J--	COIL PEAKING	15UH J RADIAL	
LA4	5CPX479K--	COIL PEAKING	4.7UH K RADIAL	
LA6	5CPX479K--	COIL PEAKING	4.7UH K RADIAL	
QA1	TKTC3198Y-	TR	KTC3198Y	
QA2	TKTC3198Y-	TR	KTC3198Y	
QA3	TKTC3198Y-	TR	KTC3198Y	
QA4	TKTC3198Y-	TR	KTC3198Y	
QA5	TKTA1266Y-	TR	KTA1266Y	
QA6	TKTC3198Y-	TR	KTC3198Y	
QA7	TKTC3198Y-	TR	KTC31986	

■ PCB NICAM AXIAL AS

A001	4859836523	PCB NICAM	T1.6X110X85(220X197/2X2)	
DA1	DIN4148---	DIODE	1N4148	

LOC.	PART-CODE	PART-NAME	PART-DESCRIPTION	REMARK
RA1	RD-AZ27AJ-	R CARBON FILM	1/6 270 OHM J	
RA10	RD-AZ562J-	R CARBON FILM	1/6 5.6K OHM J	
RA11	RD-AZ562J-	R CARBON FILM	1/6 5.6K OHM J	
RA12	RD-AZ202J-	R CARBON FILM	1/6 2K OHM J	
RA13	RD-AZ202J-	R CARBON FILM	1/6 2K OHM J	
RA14	RD-AZ153J-	R CARBON FILM	1/6 15K OHM J	
RA15	RD-AZ153J-	R CARBON FILM	1/6 15K OHM J	
RA16	RD-AZ473J-	R CARBON FILM	1/6 47K OHM J	
RA17	RD-AZ472J-	R CARBON FILM	1/6 4.7K OHM J	
RA18	RD-AZ393J-	R CARBON FILM	1/6 39K OHM J	
RA19	RD-AZ114J-	R CARBON FILM	1/6 110K OHM J	
RA2	RD-AZ271J-	R CARBON FILM	1/6 270 OHM J	
RA20	RD-AZ393J-	R CARBON FILM	1/6 39K OHM J	
RA21	RD-AZ222J-	R CARBON FILM	1/6 2.2K OHM J	
RA22	RD-AZ182J-	R CARBON FILM	1/6 1.8K OHM J	
RA23	RD-AZ222J-	R CARBON FILM	1/6 2.2K OHM J	
RA24	RD-AZ432J-	R CARBON FILM	1/6 4.3K OHM J	
RA25	RD-AZ472J-	R CARBON FILM	1/6 4.7K OHM J	
RA26	RD-AZ104J-	R CARBON FILM	1/6 100K OHM J	
RA27	RD-AZ103J-	R CARBON FILM	1/6 10K OHM J	
RA28	RD-AZ203J-	R CARBON FILM	1/6 20K OHM J	
RA29	RD-AZ223J-	R CARBON FILM	1/6 22K OHM J	
RA3	RD-AZ271J-	R CARBON FILM	1/6 270 OHM J	
RA30	RD-AZ223J-	R CARBON FILM	1/6 22K OHM J	
RA31	RD-AZ103J-	R CARBON FILM	1/6 10K OHM J	
RA32	RD-AZ103J-	R CARBON FILM	1/6 10K OHM J	
RA33	RD-AZ103J-	R CARBON FILM	1/6 10K OHM J	
RA34	RD-AZ103J-	R CARBON FILM	1/6 10K OHM J	
RA35	RD-AZ103J-	R CARBON FILM	1/6 10K OHM J	
RA36	RD-AZ103J-	R CARBON FILM	1/6 10K OHM J	
RA37	RD-AZ103J-	R CARBON FILM	1/6 10K OHM J	
RA38	RD-AZ103J-	R CARBON FILM	1/6 10K OHM J	
RA43	RD-AZ223J-	R CARBON FILM	1/6 22K OHM J	
RA5	RD-AZ202J-	R CARBON FILM	1/6 2K OHM J	
RA6	RD-AZ223J-	R CARBON FILM	1/6 22K OHM J	
RA7	RD-AZ683J-	R CARBON FILM	1/6 68K OHM J	
RA8	RD-AZ101J-	R CARBON FILM	1/6 100 OHM J	
RA9	RD-AZ101J-	R CARBON FILM	1/6 100 OHM J	

■ PCB SOUND AMP MANUAL

DS01	D1S2186---	DIODE	1S2186	
DS02	D1S21856---	DIODE	1S2186	
IS01	1TDA3866--	IC	TDA3866	
IS02	1TDA6612--	IC	TDA6612-5	
IS03	1TA8710S--	IC	TA-8710S	

LOC.	PART-CODE	PART-NAME	PART-DESCRIPTION	REMARK
LS02	58M38R9006	COIL DET	TRF-1490	
LS03	58S5590040	COIL SIF	TRF-404	
LS04	58S5590040	COIL SIF	TRF-404	
M722	48577235500	SHIELD CASE	SPTH-C T0.5	
PA01	4859274520	CONN WAFER	YFAW025-120	
SFS01	5PK9260M--	FILTER SAW	K9260M	TK, VA
SFS01	5PJ9250M--	FILTER SAW	J9250M	TU
SFS01	5PG9251M	FILTER SAW	G9251M	TF
SFS01	TPG9251M	FILTER SAW	G9251M (NICAM)	TS
SFS02	5PL9461M--	FILTER SAW	L9461M	VA
ST01	5PSFE60MB-	FILTER CERA	SFE 6.00MB	
ST02	5PSFE65MB-	FILTER CERA	SFE 6.5MB	
ST03	5PSFE55MB-	FILTER CERA	SFE 5.5MB	
ST04	5PSFE55MB-	FILTER CERA	SFE 5.5MB	
ST05	5PSFE574MC	FILTER CERA	SFE 5.74MC	
ST06	5PSFE574MC	FILTER CERA	SFE 5.74MC	
XS01	4850L00610	RESONATOR CERA	CSB500E	

■ PCB SOUND AMP RADIAL

CS01	CCXB1H471K	C CERA	50V B 470PF K (TAPPING)	
CS02	CCXB1H471K	C CERA	50V B 470PF K (TAPPING)	
CS03	CXCH1H510J	C CERA	50V CH 51PF J (TAPPING)	
CS04	CMXM2A104J	C MYLAR	100V 0.1MF J (TAPPING)	
CS05	CEXE1H479A	C ELECTRO	50V RS 4.7MF (5X11)	
CS06	CEXE1H479A	C ELECTRO	50V RS 4.7MF (5X11)	
CS07	CEXE1H479A	C ELECTRO	50V RS 4.7MF (5X11)	
CS08	CEXE1H470A	C ELECTRO	50V RSS 47MF (6.3X11)	
CS09	CEXE1H479A	C ELECTRO	50V RS 4.7MF (5X11)	
CS10	CCXB1H102K	C CERA	50V B 1000PF K (TAPPING)	
CS11	CXCH1H680J	C CERA	50V CH 68PF J (TAPPING)	
CS12	CXCH1H560J	C CERA	50V CH 56PF J (TAPPING)	
CS13	CCXF1M223Z	C CERA	50V F 0.022MF Z (TAPPING)	
CS14	CCXF1H103Z	C CERA	50V F 0.01MF Z (TAPPING)	
CS15	CCXF1H223Z	C CERA	50V F 0.022MF Z (TAPPING)	
CS16	CXCH1H680J	C CERA	50V CH 68PF J (TAPPING)	
CS17	CEXE1H479A	C ELECTRO	50V RS 4.7MF (5X11)	
CS18	CEXE1H479A	C ELECTRO	50V RS 4.7MF (5X11)	
CS19	CEXE1H479A	C ELECTRO	50V RS 4.7MF (5X11)	
CS20	CEXE1H479A	C ELECTRO	50V RS 4.7MF (5X11)	
CS21	CEXE1H479A	C ELECTRO	50V RS 4.7MF (5X11)	
CS22	CEXE1H479A	C ELECTRO	50V RS 4.7MF (5X11)	
CS23	CEXE1H479A	C ELECTRO	50V RS 4.7MF (5X11)	
CS24	CEXE1H479A	C ELECTRO	50V RS 4.7MF (5X11)	
CS25	CEXE1H479A	C ELECTRO	50V RS 4.7MF (5X11)	
CS26	CMXM2A473J	C MYLAR	100V 0.047MF J (TAPPING)	
CS27	CMXM2A473J	C MYLAR	100V 0.047MF J (TAPPING)	

LOC.	PART-CODE	PART-NAME	PART-DESCRIPTION	REMARK
CS28	CMXM2A682J	C MYLAR	100V 6800PF J (TAPPING)	
CS29	CMXM2A682J	C MYLAR	100V 6800PF J (TAPPING)	
CS30	CCXB1H222K	C CERA	50V B 2200PF K (TAPPING)	
CS31	CCXB1H681K	C CERA	50V B 680PF K (TAPPING)	
CS32	CMXM2A392J	C MYLAR	100V 3900PF J (TAPPING)	
CS33	CMXM2A104J	C MYLAR	100V 0.1MF J (TAPPING)	
CS34	CEXF1H470V	C ELECTRO	50V RSS 47MF (6.3X11)	
CS35	CEXE1H109A	C ELECTRO	50V RS 1MF (5X11)	
CS36	CEXE1H109A	C ELECTRO	50V RS 1MF (5X11)	
CS37	CMXM2A152J	C MYLAR	100V 1500PF J (TAPPING)	
C538	CMXM2A152J	C MYLAR	100V 1500PF J (TAPPING)	
CS39	CCXB1H681K	C CERA	50V B 680PF K (TAPPING)	
CS40	CCXB1H681K	C CERA	50V B 680PF K (TAPPING)	
LS01	5CPX330J--	COIL PEAKING	33UH J RADIAL	
LS05	5CPX392J--	COIL PEAKING	3900UH J RADIAL	
QS01	TKTC3198Y-	TR	KTC3198Y	
QS02	TKTC3198Y-	TR	KTC3198Y	
QS03	TKTC3198Y-	TR	KTC3198Y	
VRS01	RV5426472P	R SEMI FIXED	RH0638C 4.7K OHM B	

■ PCB SOUND AMP AXIAL

RS01	RD-AZ102J-	R CARBON FILM	1/6 1K OHM J	
RS02	RD-AZ561J-	R CARBON FILM	1/6 560 OHM J	
RS03	RD-AZ561J-	R CARBON FILM	1/6 560 OHM J	
RS04	RD-AZ561J-	R CARBON FILM	1/6 560 OHM J	
RS05	RD-AZ103J-	R CARBON FILM	1/6 10K OHM J	
RS06	RD-AZ683J-	R CARBON FILM	1/6 68K OHM J	
RS07	RD-AZ103J-	R CARBON FILM	1/6 10K OHM J	
RS09	RD-AZ103J-	R CARBON FILM	1/6 10K OHM J	
RS10	RD-AZ223J-	R CARBON FILM	1/6 22K OHM J	
RS11	RD-AZ332J-	R CARBON FILM	1/6 3.3K OHM J	
RS12	RD-AZ202J-	R CARBON FILM	1/6 2K OHM J	
RS13	RD-AZ202J-	R CARBON FILM	1/6 2K OHM J	
RS14	RD-AZ202J-	R CARBON FILM	1/6 2K OHM J	
RS15	RD-AZ471J-	R CARBON FILM	1/6 470 OHM J	
RS16	RD-AZ103J-	R CARBON FILM	1/6 10K OHM J	
RS17	RD-AZ103J-	R CARBON FILM	1/6 10K OHM J	
RS19	RD-AZ563J-	R CARBON FILM	1/6 56K OHM J	
RS20	RD-AZ100J-	R CARBON FILM	1/6 10K OHM J	
RS21	RD-AZ100J-	R CARBON FILM	1/6 10K OHM J	

■ PCB CRT MANUAL AS

50010	2193102005	SOLDER BAR	5N PB=63 47 S63S-1320	
50020	2193011101	SOLDER WIRE	RS 60-1.2 1.6A	
50030	2291050301	FLUX SOLVENT	1CAN/14KG H-302	

LOC.	PART-CODE	PART-NAME	PART-DESCRIPTION	REMARK
50040	2291050615	FLUX SOLDER	KS-892M-1	
50050	2291140501	WAX COVER		
50090	2291051001	FLUX KILLER	KFT-7	
C542	CCYE3D103P	C CERA	2KV E 0.01MF P	
C543	CEYE2E100A	C ELECTRO	250V RS 10MF (13X20)	
M681	4856812001	TIE CABLE	NYLON66 DA100	
M681	4856812001	TIE CABLE	NYLON66 DA100	
P402	4850708042	CONN AS	YBH025-08+YBIT025+ULW=500	
R501	RS02Y123J-	R M-OXIDE FILM	2W 12K OHM J	
R502	RV6117103A	R SEMI FIXED	CET 117A 10K OHM B	
R505	RV6117201A	R SEMI FIXED	CET 117A 200 OHM B	
R511	RS02Y123J-	R M-OXIDE FILM	2W 12K OHM J	
R512	RV6117103A	R SEMI FIXED	CET 117A 10K OHM B	
R515	RV6117201A	R SEMI FIXED	CET 117A 200 OHM B	
R521	RS02Y123J-	R M-OXIDE FILM	2W 12K OHM J	
R522	RV6117103A	R SEMI FIXED	CET 117A 10K OHM B	
S901	4859301930	SOCKET CRT	CVT3240-0501	21" POLKOLAR 21" SAMSUNG
S901	4859301530	SOCKET CRT	ISM-01	20" ORION
S901	4859302030	SCCKET CRT	ISM-03	21" ORION

■ PCB CRT RADIAL AS

C501	CXCH1H221J	C CERA	50V CH 220PF J (TAPPING)	
C503	CCXB1H271K	C CERA	50V B 270PF K (TAPING)	
C511	CXCH1H221J	C CERA	50V CH 220PF J (TAPPING)	
C513	CCXB1271K	C CERA	50V B 270 PF K (TAPPING)	
C521	CXCH1H221J	C CERA	50V CH 220PF J (TAPPING)	
C523	CCXB1H271K	C CERA	50V B 270PF K (TAPING)	
C541	CEXF1C101V	C ELECTRO	16V RSS 100MF (6.3X11)	
Q501	TKTC3207--	TP	KTC3207	
Q502	TKTA1266Y-	TR	KTA1266Y	
Q511	TKTC3207--	TR	KTC3207	
Q512	TKTA1266Y-	TR	KTA1266Y	
Q521	TKTC3207--	TR	KTC3207	
Q522	TKTA1266Y-	TR	KTA1266Y	

■ PCB CRT AXIAL AS

A001	4859809313	PCB CRT	51.6X89X80(269X195/3X2)	
R503	RD-AZ152J-	R CARBON FILM	1/6 1.5K OHM J	
R504	RD-AZ241J-	R CARBON FILM	1/6 240 OHM J	
R506	RC-2Z332J-	R CARBON FILM	1/2 3.3K OHM J	
R507	RD-AZ560J-	R CARBON FILM	1/6 56 OHM J	
R508	RD-AZ471J-	R CARBON FILM	1/6 470 OHM J	
R509	RD-AZ101J-	R CARBON FILM	1/6 100 OHM J	
R513	RD-AZ152J-	R CARBON FILM	1/6 1.5K OHM J	
R514	RD-AZ241J-	R CARBON FILM	1/6 240 OHM J	

LOC.	PART-CODE	PART-NAME	PART-DESCRIPTION	REMARK
R516	RC-2Z332J-	R CARBON FILM	1/2 3.3K OHM J	
R517	RD-AZ560J-	R CARBON FILM	1/6 56 OHM J	
R518	RD-AZ471J-	R CARBON FILM	1/6 470 OHM J	
R519	RD-AZ101J-	R CARBON FILM	1/6 100 OHM J	
R523	RD-AZ152J-	R CARBON FILM	1/6 1.5K OHM J	
R524	RD-AZ241J-	R CARBON FILM	1/6 240 OHM J	
R525	RD-AZ201J-	R CARBON FILM	1/6 200 OHM J	
R526	RC-2Z332J-	R CARBON FILM	1/2 3.3K OHM J	
R527	RD-AZ560J-	R CARBON FILM	1/6 56 OHM J	
R528	RD-AZ471J-	R CARBON FILM	1/6 470 OHM J	
R541	RD-AZ621J-	R CARBON FILM	1/6 620 OHM J	
R542	RD-AZ472J-	R CARBON FILM	1/6 4.7K OHM J	
R543	RD-AZ472J-	R CARBON FILM	1/6 4.7K OHM J	
R544	RD-AZ472J-	R CARBON FILM	1/6 4.7K OHM J	
R550	RD-AZ103J-	R CARBON FILM	1/6 10K OHM J	
R551	RD-AZ103J-	R CARBON FILM	1/6 10K OHM J	
R552	RD-AZ103J-	R CARBON FILM	1/6 10K OHM J	

■ PCB LED AS (2166Model, 65mmx34mm)

LOC.	PART-CODE	PART-NAME	PART-DESCRIPTION	REMARK
DL01	DKLR114L--	LED	KLR114L	
DL02	DKLR114L--	LED	KLR114L	
PL02	4850705020	CONN AS	TY025-05+YST025+ULW=500	
QL01	TKTC3198Y-	TR	KTC3198Y	
QL02	TKTC3198Y-	TR	KTC3198Y	
RL01	RD-AZ472J-	R CARBON FILM	1/6 4.7K OHM J	
RL02	RD-AZ472J-	R CARBON FILM	1/6 4.7K OHM J	
RL03	RD-AZ391J-	R CARBON FILM	1/6 360 OHM J	
RL04	RD-AZ391J-	R CARBON FILM	1/6 360 OHM J	

■ PCB LED AS (2075Model, 40mmx34mm)

LOC.	PART-CODE	PART-NAME	PART-DESCRIPTION	REMARK
DL01	DKLR114L	LED	KLR114L	
DL02	DKLR114L	LED	KLR114L	
DL02	4850705020	CONN AS	YH025-05+YST05+ULW=500	
QL01	TKTC3198Y	TR	KTC3198Y	
QL02	TKTC3198Y	TR	KTC3198Y	
RL01	RD-AZ472J-	R CARBON FILM	1/6 4.7K OHM J	
RL02	RD-AZ472J-	R CARBON FILM	1/6 4.7K OHM J	
RL03	RD-AZ391J-	R CARBON FILM	1/6 390 OHM J	
RL04	RD-AZ391J-	R CARBON FILM	1/6 390 OHM J	

EXPLODED VIEW

DTT-2066

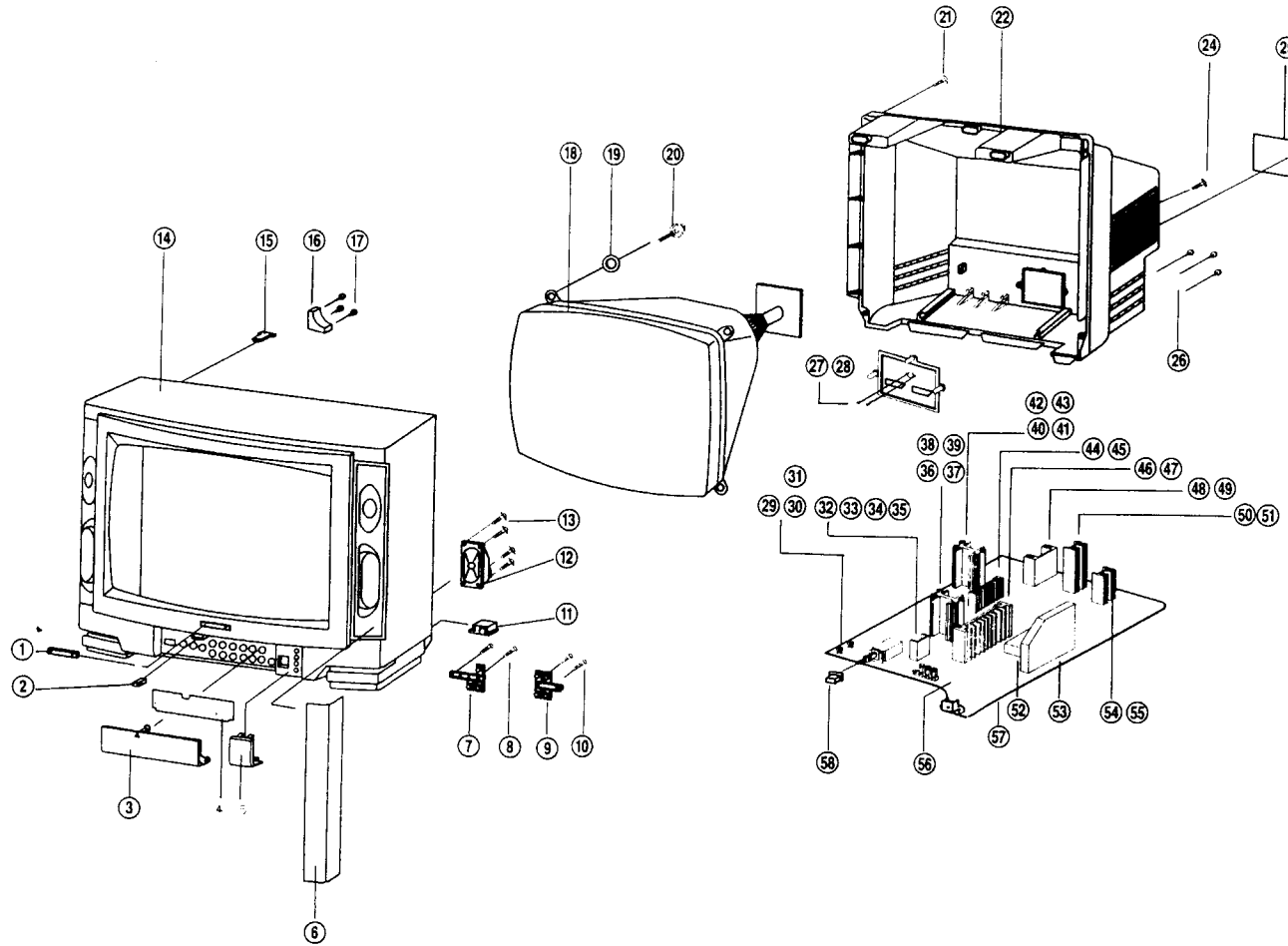

NO.	PART CODE	PART NAME	Q'TY	DESCRIPTION	REMARK
1	4855615900	MARK BRAND	1	A1050P-H24 T0.4	
2	4857923300	DOOR LOCK	1	LA701(DIFCO)	
3	4852810701	DOOR	1	ABS BK	
4	4855050605	DECO CTRL	1	PVC T0.25	
5	4855513803	DECO SENSOR	1	P.C DARK RED	
6	4852519000	GRILL	2	EGI T0.8 BK	
7	4854916610	BUTTON CTRL 'B'	1	HG ABS BK	
8	7128301011	SCREW TAPPING	2	T2S WAS 3X10 MFZN	BUTON+M/F
9	4854915802	BUTTON	1	ABS BK	
10	7128301011	SCREW TAPPING	2	T2S WAS 3X10 MFZN	BUTON+M/F
11	4853525501	HOLDER CORD	1	HIPS GY	
12	4858304020	SPEAKER	2		
13	7128301211	SCREW TAPPING	8	T2S WAS 3X12 MFZN	SPER +M/F
14	4852040701	MASK FRONT	1	HIPS BK	
15	4853311801	RETA BACK	3	HIPS NC	
16	4853115001	BRKT CRT	4	ABS NC	
17	7121401611	SCREW TAPPING	12	T2S PAN 4X16 MFZN	BUTON+M/F
18	4859605660	CRT	1		
19	4856215402	WASHER RUBBER	4	TMR-CA/NF BK T2	
20	4856212000	WASHER CRT FIX	4	SK-5 B.K T1.2	
21	7122401411	SCREW TAPPING	5	T2S TRS 4X14 MFZN	MF/+C/B
22	4852129500	COVER BACK	1	FR HIPS BK	
23					
24	7122401411	SCREW TAPPING	1	T2S TRS 4X14 MFZN	C/B+FBT
25	4855415800	SPEC PLATE	1	150ART P/E FILM(C/TV)	
26	7122401411	SCREW TAPPING	3	T2S TRS 4X14 MFZN	BC+TERM
27	4853624802	TERMINAL ANT	1	HIPS BK	
28	7128261011	SCREW TAPPING	2	T2S PAN 3X8 MFZN	
29	4857415001	FUSE CLIP	1	PFC5000-0702	
30	4857415001	FUSE CLIP	1	PFC5000-0702	
31	4857621200	INSU COVER	1	PVC T1.0(94V-0)	
32	4857025400	HEAT SINK	1	AL EX	
33	4857025400	SCREW SPECIAL	1	PAN 3X10 MFZN	
34	4856215200	WASHER	1	SPCC	
35	7392300011	NUT HEX	1	6N-2-3 MFZN	
36	4857024502	HEAT SINK	1	AL EX	
37	4856012312	SCREW SPECIAL	1	PAN 3X12 MFZN	
38	4856215201	WASHER	1	SPCC	
39	7392300011	NUT HEX	1	6N-2-3 MFZN	
40	4857024502	HEAT SINK	1	AL EX	
41	4856012312	SCREW SPECIAL	1	PAN 3X12 MFZN	
42	4856215201	WASHER	1	SPCC	
43	7392300011	NUT HEX	1	6N-2-3 MFZN	
44	4857024900	HEAT SINK	1	AL EX	
45	7271301011	SCREW TAPTITE	1	TT3 PAN 3X10 MFZN	
46	4857024405	HEAT SINK	1	AL EX	
47	7271301011	SCREW TAP TITE	1	TT3 PAN 3X10 MFZN	
48	4857024601	HEAT SINK	1	AL EX	
49	7271301011	SCREW TAP TITE	2	TT3 PAN 3X10 MFZN	
50	4857024900	HEAT SINK	1	AL EX	
51	7271301011	SCREW TAP TITE	1	TT3 PAN 3X10 MFZN	
52	4857235400	SHIELD CASE	1	SPTH-C T0.25	
53	4857235600	SHIELD CASE	1	SPTH-C T0.25	
54	4857024902	HEAT SINK	1	AL EX	
55	7271300811	SCREW TAPPING	1	T2S PAN 3X8 MFZN	
56	9850136506	MAIN PCB	1		
57	4857235600	SHIELD PLATE	1	SPTH-C T0.25	CP-365
58	4854814400	BUTTON POWER	1	ABS BK	

■ DTT-2075

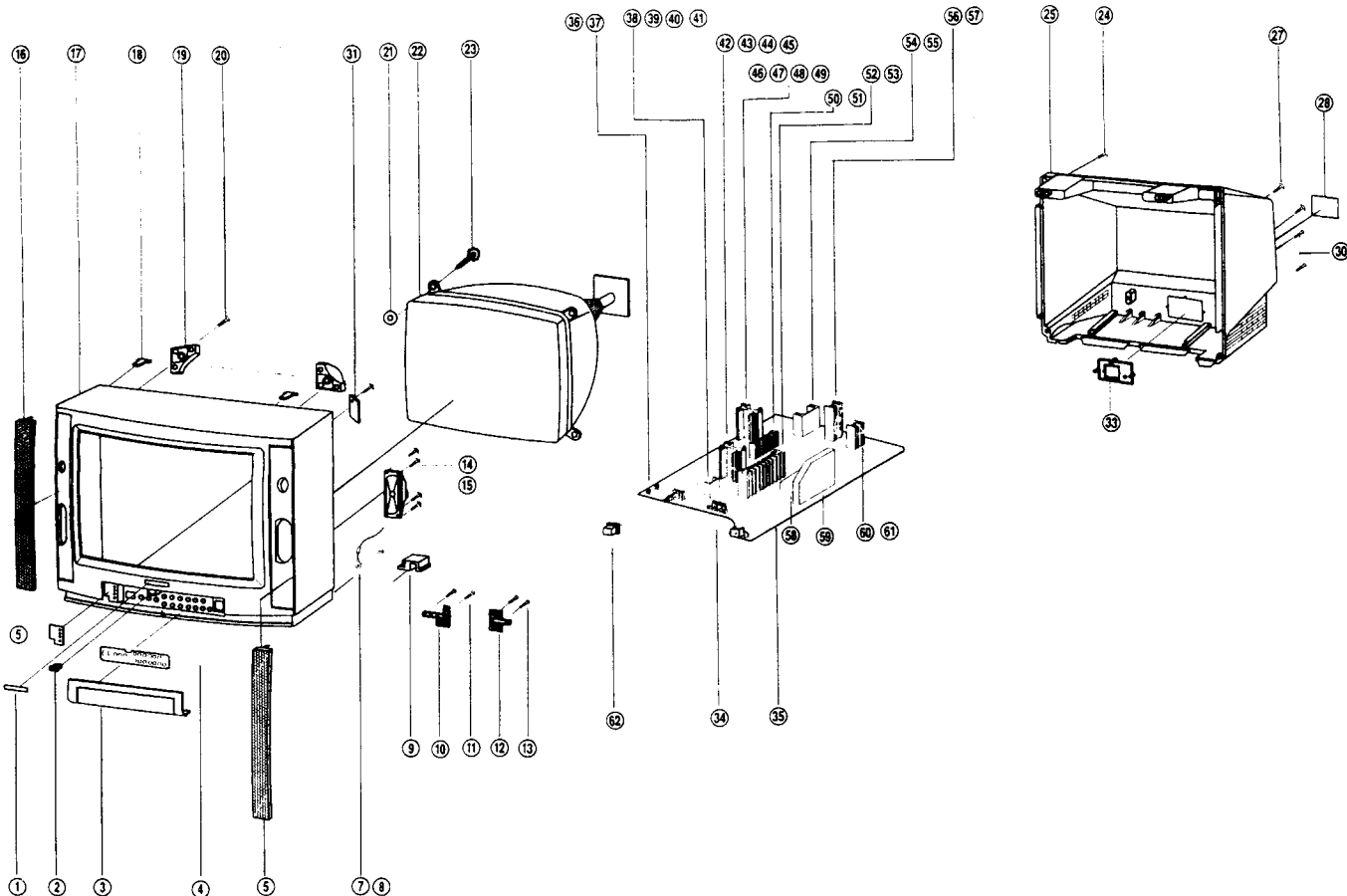

NO.	PART CODE	PART NAME	Q'TY	DESCRIPTION	REMARK
1	4855615900	MARK BRAND	1	A1050P-H24	
2	4857923300	DOOR LOCK	1	LA701(KIFCO)	
3	4852813904	DOOR	1	PC SMOG	
4	4855051405	DECO CTRL	1	PVC T0.25	
5	4855117004	DECO SENSOR	1	PVC CL T0.5	
6	4852523400	GRILL R	2	EGI T0.8 BK	
7	4851900120	GRILL GROUND AS	1	DS-W1008-RC5RCM	
8	7128301011	SCREW TAPPING	2	T2S WAS 3X10 MFZN	BUTON+M/F
9	4853525500	HOLDER CORD	1	FR HIPS BK	
10	4854916610	BUTTON CTRL "B"	1	HG ABS BK	
11	7128301011	SCREW TAPPING	2	T2S WAS 3X10 MFZN	BUTON+M/F
12	4854915802	BUTTON	1	ABS BK	
13	7128301011	SCREW TAPPING	2	T2S WAS 3X10 MFZN	BUTON+M/F
14	4852523500	GRILL L	1	EGI T0.8 BK	
15	4858304020	SPEAKER	2	5W 80HM 125BFDLC/608BA	
16	7128301211	SCREW TAPPING	8	T2S WAS 3X12 MFZN	SPER+M/F
17	4852045001	MASK FRONT	1	HIPS BK	
18	4853311601	RETA BACK	2	HIPS NC	
19	4853115001	BRKT CRT	4	ABS NC	
20	7121401611	SCREW TAPPING	12	T2S PAN 4X16 MFZN	BUTON+M/F
21	4856215402	WASHER RUBBER	4	TMR-CA/NF BK T2	
22		CRT	1		
23	4856212000	SCREW CR TPIX	4	SWRH+SK-5 (L=30)	
24	7122401411	SCREW TAPPING	4	T2S TRS 4X14 MFZN	M/F+C/B
25	4852132600	COVER BACK	1	FR HIPS BK	
26					
27	7122401411	SCREW TAPPING	1	T2S TRS 4X14 MFZN	C/B+FBT
28	4855415800	SPEC PLATE	1	150ART P/E FILM(C/TV)	
29	7122401411	SCREW TAPPING	3	T2S TRS 4X14 MFZN	C/B+ANT BOARD
30	7128301011	SCREW TAPPING	2	T2S WAS 3X10 MFZN	T/A+A/B
31	7128301211	SCREW TAPPING	1	T2S WAS 3X12 MFZN	L/P+M/F
32	7128301211	SCREW TAPPING	1	T2S WAS 3X12 MFZN	L/P+M/F
33	4853624802	TERM ANT	1	FR HIPS BK	
34	9850136504	MAIN PCB AS	1		CP-365
35	4857235600	SHIELD PLATE	1	SPTH-C T0.25	
36	4857415001	FUSE CLIP	1	PFC5000-0702	
37	4857415001	FUSE SLIP	1	PFC5000-0702	
38	4857025400	HEAT SINK	1	AL EX	
39	4856012310	SCREW SPECIAL	1	PAN 3X10 MFZN	
40	4856215200	WASHER	1	SPCC	
41	7392300011	NUT HEX	1	6N-2-3 MFZN	
42	4857024502	HEAT SINK	1	AL EX	
43	4856012312	SCREW APECIAL	1	PAN 3X12 MFZN	
44	4856215201	WASHER	1	PAN 3X12 MFZN	
45	7392300011	NUT HEX	1	6N-2-3 MFZN	
46	4857024502	HEAT SINK	1	AL EX	
47	4856012312	SCREW SPECIAL	1	PAN 3X12 MFZN	
48	4856215201	WASHER	1	SPCC	
49	7392300011	NUT HEX	1	6N-2-3 MFZN	
50	4857024900	HEAT SINK	1	AL EX	
51	7271301011	SCREW TAPTITE	1	TT3 PAN 3X10 MFZN	
52	4857024405	HEAT SINK	1	AL EX	
53	7271301011	SCREW TAPTITE	1	TT3 PAN 3X10 MFZN	
54	4857024601	HEAT SINK	1	AL EX	
55	7271301011	SCREW TAPTITE	2	TT3 PAN 3X10 MFZN	
56	4857024900	HEAT SINK	1	AL EX	
57	7121260811	SCREW TAPPING	1	T2S PAN 3X8 MFZN	
58	4857235400	SHIELD CASE	1	SPTH-C T0.25	
59	4857235500	SHIELD CASE	1	SPTH-C T0.25	
60	4857024902	HEAT SINK	1	AL EX	
61	7121300811	SCREW TAPPING	1	T2S PAN 3X8 MFZN	
62	4854814400	BUTTON POWER	1	ABS BK	

■ DTT-20C1

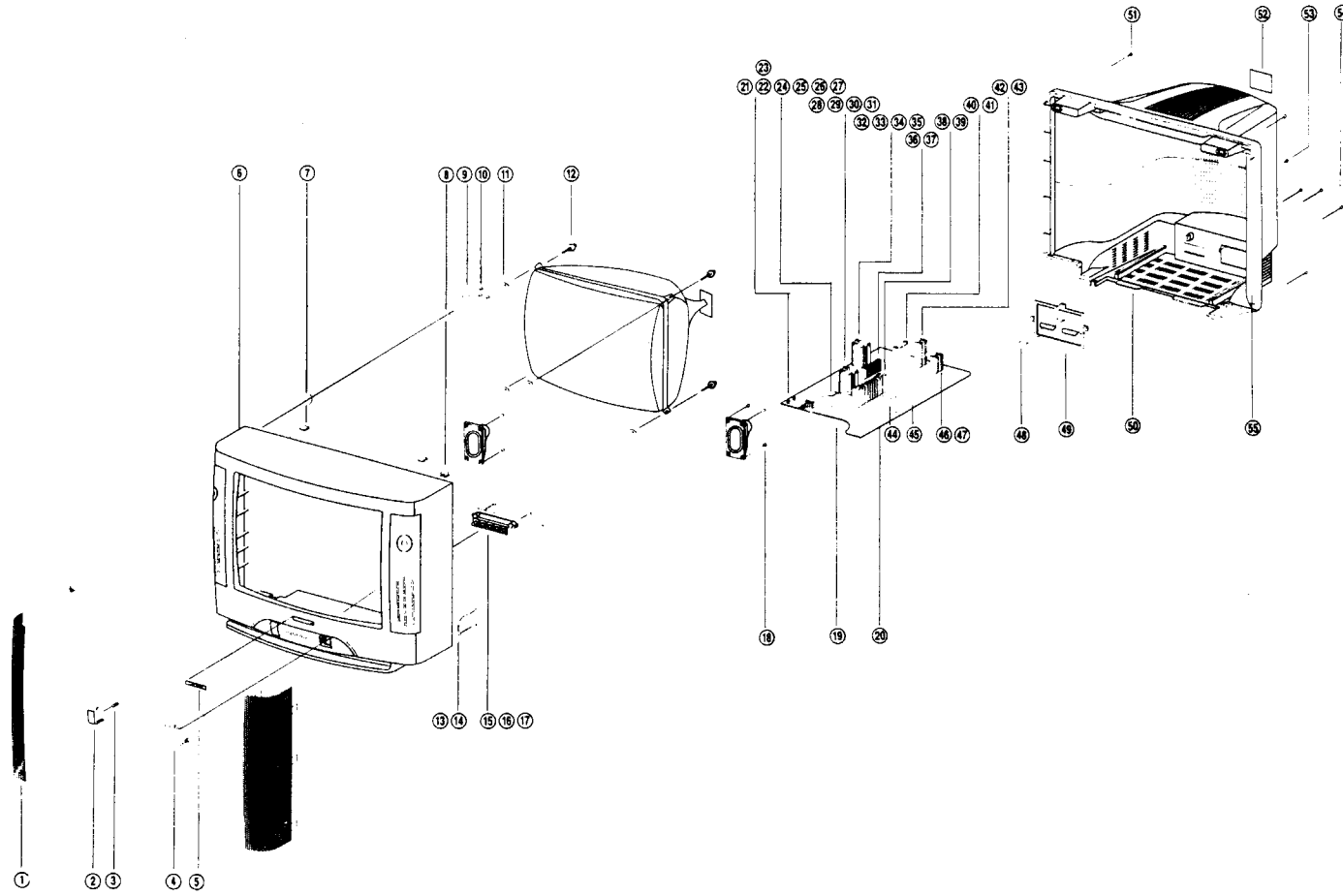

NO.	PART CODE	PART NAME	Q'TY	DESCRIPTION	REMARK
1	4852524900	GRILL	2	EGI T0.5+SPONGE	
2	4854836801	BUTTON POWER	1	ABS BK	
3	4856717900	SPRING	1	SWPA	
4	4855518401	DECO SENSOR	1	P.C SMOG	
5	4855615900	MARK BRAND	1	A1050P-H24 T0.4	
6	4852046401	MASK FRONT	1	HIPS BK	
7	4853311601	RETAINER BACK	2	HIPS NC	
8	4853525500	HOLDER CORD	1	HIPS BK	
9	4853115001	BRACKET	4	ABS NC	
10	7121401611	SCREW TAPPING	12	T2S PAN 4X16	MFZN
11	9976210400	WASHER RUBBER	4	RUBBER BK	POLKOLOR
12	4856215402	WASHER RUBBER	4	CR	
12	4856212000	SCREW CRT	FIX	4	SUPM-3K-5L=30
13	4851900120	GRILL GROUND AS.	2	DS-W1007-RC5RCM	
14	7128301011	SCREW TAPPING	2	T2S WAS 3X10 MFZN	
15	4854920701	BUTTON	1	ABS BK	
16	7128301011	SCREW TAPPING	2	T2S WAS 3X10 MFZN	
17	4853528101	HOLDER	1	HIPS BK	
18	7128301011	SCREW TAPPING	8	T2S WAS 3X10 MFZN	
19	9850136506	MAIN PCB AS	1	CP-365	
20	4857235600	SHIELD PLATE	1	SPTH-C T0.25	
21	4857415001	FUSE SLIP	1	PFC5000-0702	
22	4857415001	FUSE CLIP	1	PFC5000-0702	
23	4857621200	INSU COVER	1	PVC T1.0(94V-0)	
24	4857025400	HEAT SINK	1	AL EX	
25	4856012310	SCREW SPECIAL	1	PAN 3X10 MFZN	
26	4856215200	WASHER	1	SPCC	
27	7392300011	NUT HEX	1	6N-2-3 MFZN	
28	4857024502	HEAT SINK	1	AL EX	
29	4856012312	SCREW SPECIAL	1	PAN 3X12 MFZN	
30	4856215201	WASHER	1	SPCC	
31	7392300011	NUT HEX	1	6N-2-3 MFZN	
32	4857024502	HEAT SINK	1	AL EX	
33	4856012312	SCREW SPECIAL	1	PAN 3X12 MFZN	
34	4856215201	WASHER	1	SPCC	
35	7392300011	NUT HEX	1	6N-2-3 MFZN	
36	4857024900	HEAT SINK	1	AL EX	
37	7271301011	SCREW TAPTITE	1	TT3 PAN 3X10 MFZN	
38	4857024405	HEAT SINK	1	AL EX	
39	7271301011	SCREW TAPTITE	1	TT3 PAN 3X10 MFZN	
40	4857024601	HEAT SINK	1	AL EX	
41	7271301011	SCREW TAPTITE	2	TT3 PAN 3X8 MFZN	
42	4857024900	HEAT SINK	1	AL EX	
43	7121260811	SCREW TAPPING	1	T2S PAN 3X8 MFZN	
44	4857235400	SHIELD CASE	1	SPTH-C T0.25	
45	4857235500	SHIELD CASE	1	SPTH-C T0.5	
46	4857024902	HEAT SINK	1	AL EX	
47	7121300811	SCREW TAPPING	1	T2S PAN 3X8 MFZN	
48	7128261011	SCREW TAPPING	2	T2S WAS 2.6X10 MFZN	
49	4853624802	TERMINAL ANT	1	HIPS BK	
50	4852133900	COVER BACK	1	FR HIPS BK	
51	7122401411	SCREW TAPPING	4	T2S TRS 4X14 MFZN	BC+MF
52	4855415800	SPEC PLATE	1	150ART P/E FILM	
53	7122401411	SCREW TAPPING	1	T2S TRS 4X14 MFZN	BC+FBT
54	7122401411	SCREW TAPPING	3	T2S TRS 4X14 MFZN	BC-TERM
55	4857817610	CLOTH BLACK	3	FELT T0.7 L=300	

DTT-2166

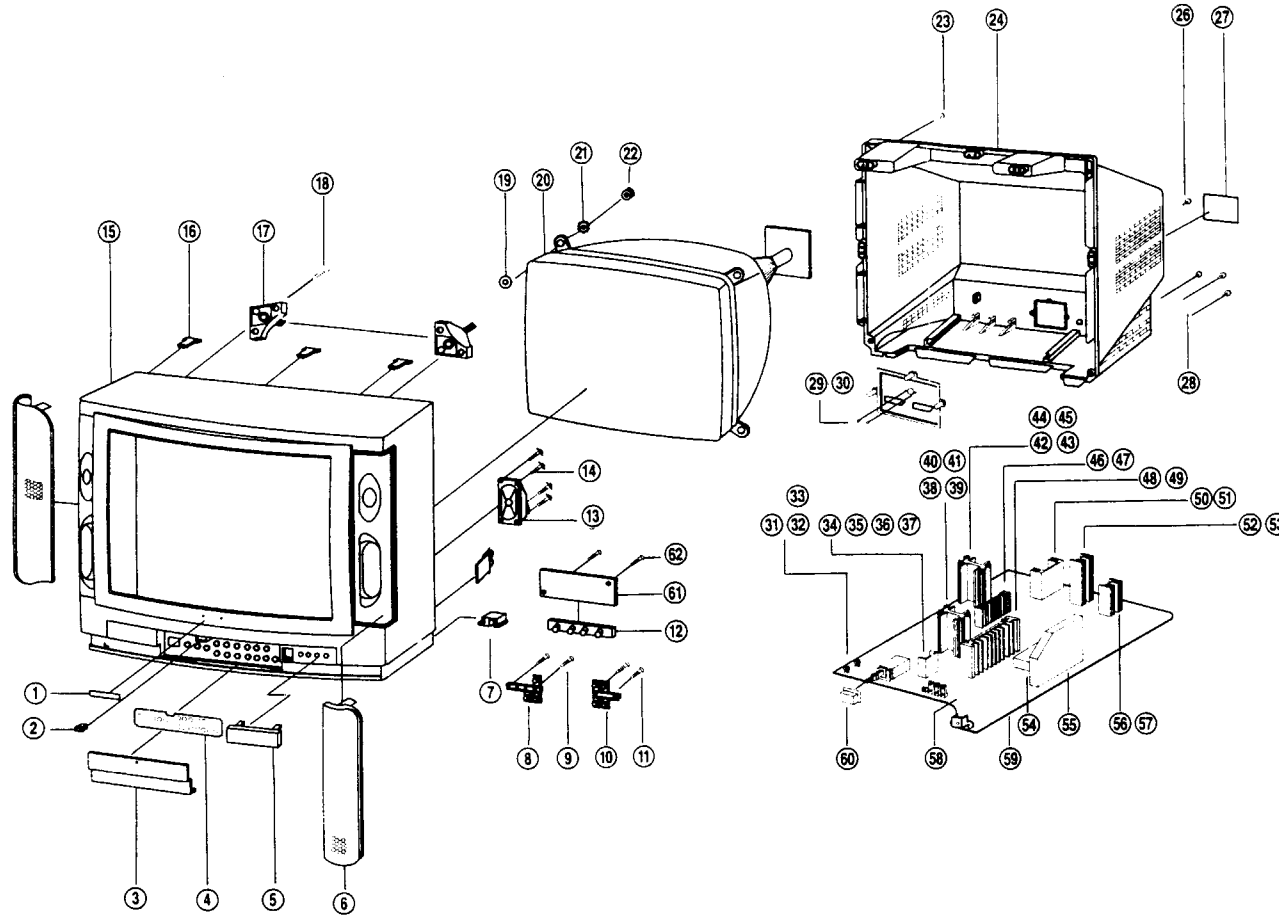

NO.	PART CODE	PART NAME	Q'TY	DESCRIPTION	REMARK
1	4855817200	MARK BRAND	1	A1050P-H24	
2	4857923300	DOOR LOCK	1	LA701(KIFCO)	
3	4852811701	DOOR	1	ABS BK	
4	4855051405	DECO CTRL	1	PVC T0.25	
5	4855514404	DECO SENSOR	1	P C DARK RED	
6	4852520500	GRILL	2	EGT 0.8 BK	
7	4853525501	HOLDER CORD	1	HIPS BK	
8	4854916610	BUTTON CTRL "B"	1	HG ABS BK	
9	7128301011	SCREW TAPPING	2	T2S WAS 3X10 MFZN	BUTON+M/F
10	4854915802	BUTTON	1	ABS BK	
11	7128301011	SCREW TAPPING	2	T2S WAS 3X10 MFZN	BUTON+M/F
12	4853524101	HOLDER LED	1	HIPS BK	
13	4858304020	SPEAKER	2		
14	7128301211	SCREW TAPPING	8	T2S WAS 3X12 MFZN	SPER+M/F
15	4852041601	MASK FRONT	1	HIPS BK	
16	4853311601	RETA BACK	5	HIPS NC	
17	4853414401	BRKT CRT	4	ABS NC	
18	7121401611	SCREW TAPPING	12	T2S PAN 4X16 MFZN	BUTON+M/F
19	4856214800	WASHER RUBBER	4	TMR-CA/NF BK T2	
20	4859605660	CRT	1		
21	4856213200	WASHER CRT FIX	4	SK-5 B.K T1.2	
22	7391500011	NUT HEX	4	6N-1.5 MFZN	
23	7122401411	SCREW TAPPING	7	T2S TRS 4X14 MFZN	M/F+C/B
24	4852130100	COVER BACK	1	FR HIPS BK	
25					
26	7122401411	SCREW TAPPING	1	T2S TRS 4X14 MFZN	C/B+FBT
27	4855415800	SPEC PLATE	1	150ART P/E FILM(C/TV)	
28	7122401411	SCREW TAPPING	3	T2S TRS 4X14 MFZN	BC+TERM
29	4853624802	TERMINAL ANT	1	HIPS BK	
30	7128261011	SCREW TAPPING	2	T2S PAN 3X8 MFZN	
31	4857415001	FUSE CLIP	1	PFC5000-0702	
32	4857415001	FUSE CLIP	1	PFC5000-0702	
33	4857621200	INSU COVER	1	PVC T1.094V-0)	
34	4857025400	HEAT SINK	1	AL EX	
35	4857025400	SCREW SPECIAL	1	PAN 3X10 MFZN	
36	4856215200	WASHER	1	SPCC	
37	7392300011	NUT HEX	1	6N-2-3 MFZN	
38	4857024502	HEAT SINK	1	AL EX	
39	4856012312	SCREW SPECIAL	1	PAN 3X12 MFZN	
40	4856215201	WASHER	1	SPCC	
41	7392300011	NUT HEX	1	6N-2-3 MFZN	
42	4857024502	HEAT SINK	1	AL EX	
43	4856012312	SCREW SPECIAL	1	PAN 3X12 MFZN	
44	4856215201	WASHER	1	SPCC	
45	7392300011	NUT HEX	1	6-2-3 MFZN	
46	4857024900	HEAT SINK	1	AL EX	
47	7271301011	SCREW TAPTITE	1	TT3 PAN 3X10 MFZN	
48	4857024405	HEAT SINK	1	AL EX	
49	7271301011	SCREW TAPTITE	1	TT3 PAN 3X10 MFZN	
50	4857024601	HEAT SINK	1	AL EX	
51	7271301011	SCREW TAPTITE	2	TT3 PAN 3X10 MFZN	
52	4857024900	HEAT SINK	1	AL EX	
53	7271301011	SCREW TAPTITE	1	TT3 PAN 3X10 MFZN	
54	4857235400	SHIELD CASE	1	SPTH-C T0.25	
55	4857235500	SHIELD CASE	1	SPTH-C T0.25	
56	4857024902	HEAT SINK	1	AL EX	
57	7271300811	SCREW TAPPING	1	T2S PAN 3X8 MFZN	
58	9850136506	MAIN PCBA	1		
59	4857235600	SHIELD PLATE	1	SPTH-C T0.25	CP-365
60	4854814400	BUTTON POWER	1	HIPS BK	
61	4859812314	PCB CONTROL	1		
62	7128301011	SCREW TAPPING	2	T2S WAS 3X10 MFZN	

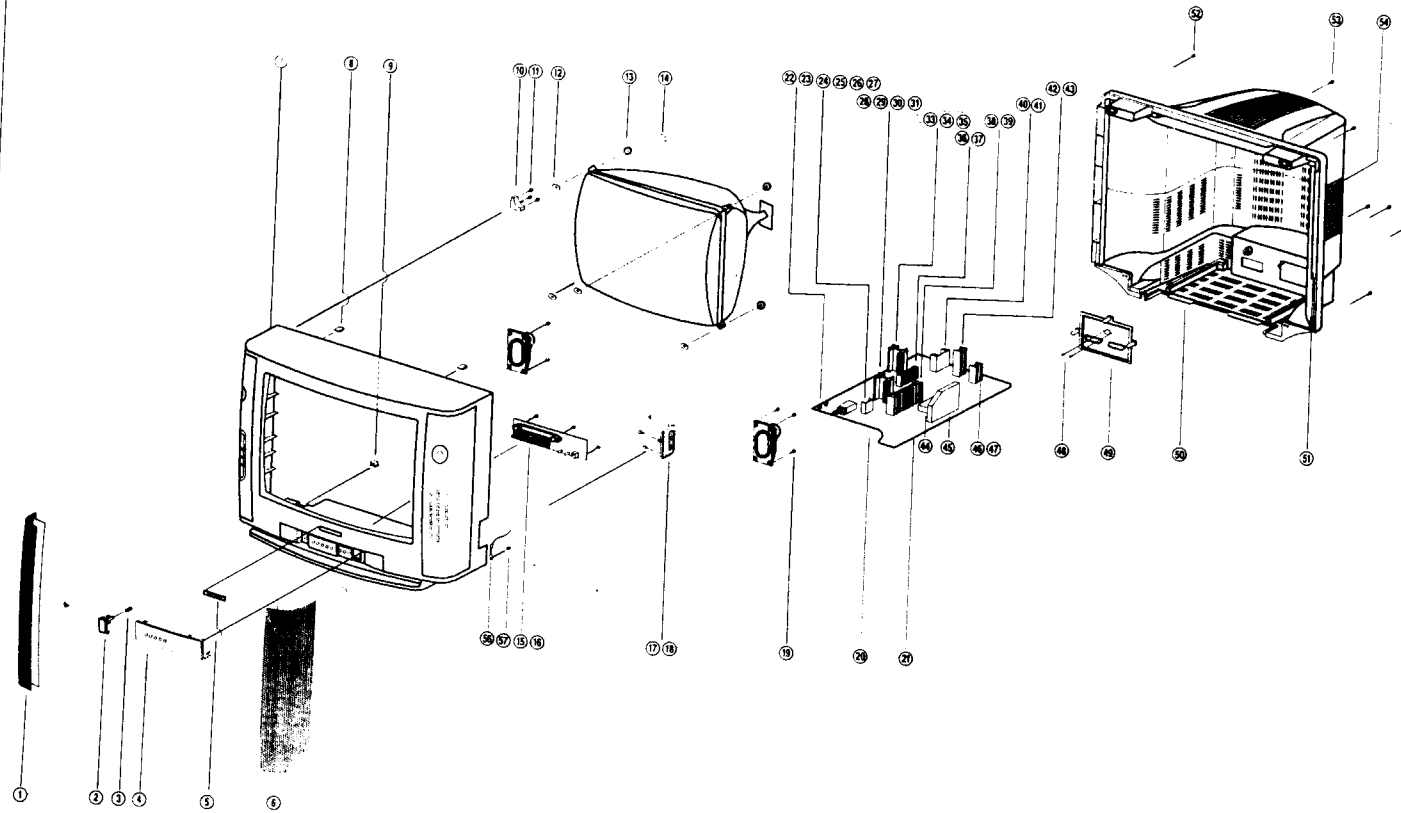

NO.	PART CODE	PART NAME	Q'TY	DESCRIPTION	REMAR
1	4852525100	GRILL L	1	EGI T0.5+SPONGE	
2	4854836901	BUTTON POWER	1	ABS BK	
3	4856717900	SPRING	1	SWPA	
4	4855518501	DECO SENSOR	1	P.C SMOG	
5	4855617500	MARK BRAND	1	CU AU-ABS BK	
6	4852525000	GRILL R	1	EGI T0.5+SPONGE	
7	4852048501	MASK FRONT	1	HIPS BK	
8	4853311601	RETAINER BACK	2	HIPS NC	
9	4853525501	HOLDER CORD	1	HIPS GY	
10	4853414401	BRKT CRT	4	ABS NC	
11	7121401611	SCREW TAPPING	12	T2S PAN 4X16 MFZN	
12	4856215402	WASHER RUBBER	4	CR	
13	4856213200	WASHER CRT FIX	4	SK-5 8.K T1.2	
14	7391500011	NUT HEX	4	6N-1-5 MFZN	
15	4854920801	BUTTON	1	ABS BK	
16	7128301011	SCREW TAPPING	3	T2S WAS 3X10 MFZN	
17	4852317601	AV PANNEL	1	HIPS BK	
18	7128301011	SCREW TAPPING	3	T2S WAS 3X10 MFZN	
19	7128301011	SCREW TAPPING	8	T2S WAS 3X10 MFZN	
20	9850136504	MAIN PCB AS	1		
21	4857236600	SHIELD PLATE	1	SPTH-C T0.25	
22	4857415001	FUSE CLIP	1	PFC5000-0702	
23	4857415001	FUSE CLIP	1	PFC5000-0702	
24	4857025401	HEAT SINK	1	AL EX	
25	4856012310	SCREW SPECIAL	1	PAN 3X10 MFZN	
26	4856215200	WASHER	1	SPCC	
27	7392300011	NUT HEX	1	6N-2-3 MFZN	
28	4857024502	HEAT SINK	1	AL EX	
29	4856012312	SCREW SPECIAL	1	PAN 3X12 MFZN	
30	4856215201	WASHER	1	PAN 3X12 MFZN	
31	7392300011	NUT HEX	1	6N-2-3 MFZN	
32	4857024502	HEAT SINK	1	AL EX	
33	4856012312	SCREW SPECIAL	1	PAN 3X12 MFZN	
34	4856215201	WASHER	1	SPCC	
35	7392300011	NUT HEX	1	6N-2-3 MFZN	
36	4857024900	HEAT SINK	1	AL EX	
37	7271301011	SCREW TAPTITE	1	TT3 PAN 3X10 MFZN	
38	4857024405	HEAT SINK	1	AL EX	
39	7271301011	SCREW TAPTITE	1	TT3 PAN 3X10 MFZN	
40	4857024601	HEAT SINK	1	AL EX	
41	7271300811	SCREW TAPTITE	2	TT3 PAN 3X8 MFZN	
42	4857024900	HEAT SINK	1	AL EX	
43	7121260811	SCREW TAPPING	1	T2S PAN 3X8 MFZN	
44	4857235400	SHIELD CASE	1	SPTH-C T0.25	
45	4857235500	SHIELD CASE	1	SPTH-C T0.25	
46	4857024902	HEAT SINK	1	AL EX	
47	7121300811	SCREW TAPPING	1	T2S PAN 3X8 MFZN	
48	7128261011	SCREW TAPPING	2	T2S WAS 2.6X10 MFZN	
49	4853624802	TERMINAL ANT	1	HIPS BK	
50	4852134000	COVER BACK	1	FR HIPS BK	
51	4857817601	CLOTH BLACK	3	FELT T0.7 L=300	
52	7128261011	SCREW TAPPING	4	T2S TRS 4X14 MFZN	7+50
53	4855415800	SPEC PLATE	1	150ART P/E FILM(IC/TV)	
54	7128261011	SCREW TAPPING	1	T2S TRS 4X14 MFZN	50+20
55	7128261011	SCREW TAPPING	3	T2S TRS 4X14 MFZN	49+50
56	4851900120	GRILL GROUND AS	2	DS-W1007-RCSRCM	
57	7128301011	SCREW TAPPING	2	T2S WAS 3X10 MFZN	1.6+7

■ DTT-21B1

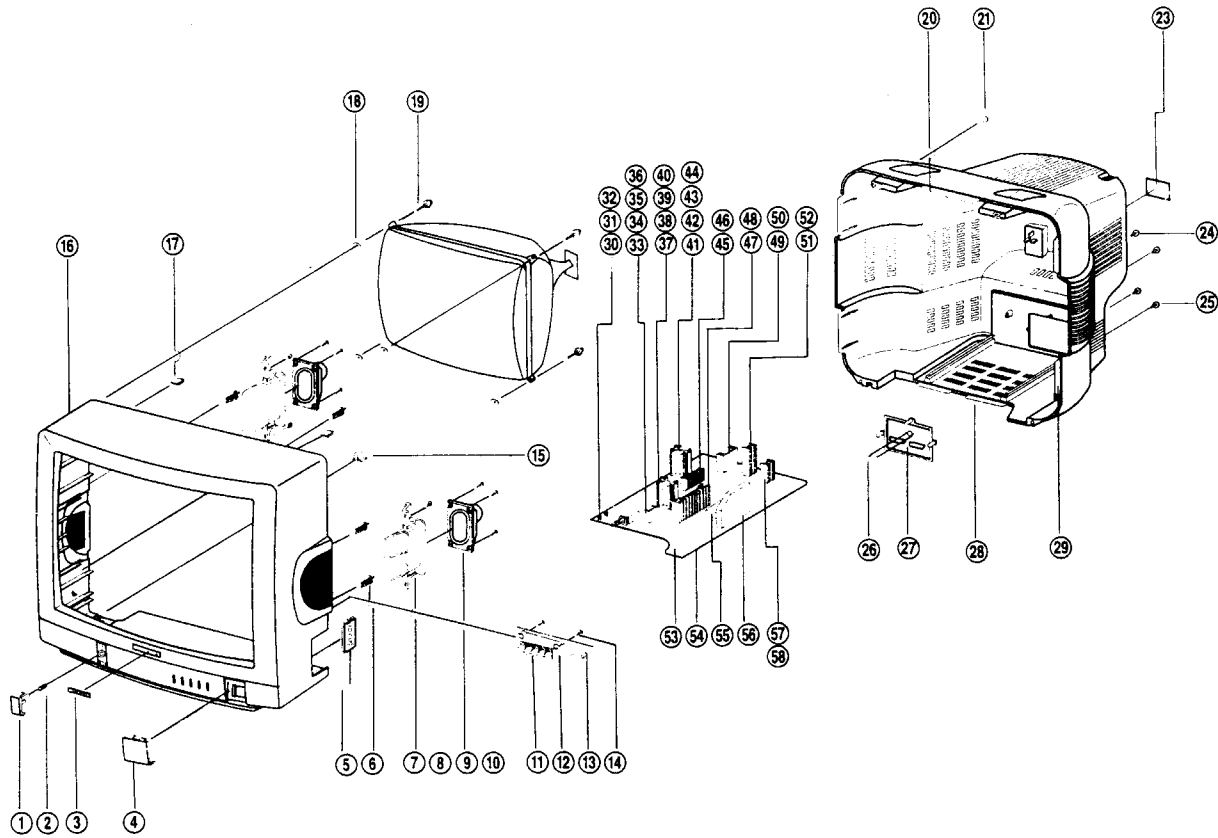

NO.	PART CODE	PART NAME	Q'TY	DESCRIPTION	REMARK
1	4854837301	BUTTON POWER	1	ABS BK	
2	4856717900	SPRING	1	SWPA	
3	4855615900	MARK BRAND	1	A1050P-H24 T0.4	
4	4855518901	DECO SENSOR	1	P.C SMOG	
5	4852317601	PANEL AVV	1	HIPS BK	
6	4853743001	RETA	4	HIPS NC	
7	4853945201	BRKT SPKR	2	HIPS BK	
8	7122401411	SCREW TAPPING	4	T2S TRS 4X14 MFZN	RETA+BRKT
9	4858304920	SPEAKER	2	5W 8 OHM MSF-2D4SB53D	
10	7128301011	SCREW TAPPING	8	T2S WAS 3X10 MFZN	SPKR+BRKT
11	4854921101	BUTTON	1	ABS BK	
12		CONTROL PCB	1		
13	4853528101	LED HOLDER	1	HIPS BK	
14	7128301011	SCREW TAPPING	2	T2S WAS 3X10 MFZN	
15	4853525500	HOLDER CORD	1	FR HIPS BK	
16	4852046901	MASK FRONT	1	HIPS BK	
17	4853311601	RETAINER BACK	2	HIPS NC	
18	4856215402	WASHER RUBBER	4	CR	
19	4856212000	SCREW CRT FIX	4	SWRM+SK-5L-30	
20	4857817620	CLOTH BLACK	1	FELT T0.5 L=100	
21	7122401411	SCREW TAPPING	4	T2S TRS 4X14 MFZN	MF+C/B
22					
23	4855415800	SPEC PLATE	1	150ART P/E FILM	
24	7122401411	SCREW TAPPING	1	T2S TRS 4X14 MFZN	C/B+FBT
25	7122401411	SCREW TAPPING	3	T2S TRS 4X14 MFZN	C/B-TERM
26	7128261011	SCREW TAPPING	2	T2S WAS 2.6X10MFZN	TERM+PLUG
27	4853624802	TERMINAL ANT	1	HIPS BK	
28	4852134400	COVER BACK	1	FR HIPS BK	
29	4857817620	CLOTH BLACK	4	FELT T0.5 L=100	
30	4857415001	FUSE CLIP	1	PFC5000-0702	
31	4857415001	FUSE CLIP	1	PFC5000-0702	
32	4857621200	INSU COVER	1	PVC T1 (Q94V-0)	
33	4857025400	HEAT SINK	1	AL EX	
34	4857025400	SCREW SPECIAL	1	PAN 3X10 MFZN	
35	4856215200	WASHER	1	SPCC	
36	7392300011	NUT HEX	1	6N-2-3 MFZN	
37	4857024502	HEAT SINK	1	AL EX	
38	4856012312	SCREW SPECIAL	1	PAN 3X12 MFZN	
39	4856215201	WASHER	1	SPCC	
40	7392300011	NUT HEX	1	6N-2-3 MFZN	
41	4857024502	HEAT SINK	1	AL EX	
42	4856012312	SCREW SPECIAL	1	PAN 3X12 MFZN	
43	4856215201	WASHER	1	SPCC	
44	7392300011	NUT HEX	1	6N-2-3 MFZN	
45	4857024900	HEAT SINK	1	AL EX	
46	7271301011	SCREW TAPTITE	1	TT3 PAN 3X10 MFZN	
47	4857024405	HEAT SINK	1	AL EX	
48	7271301011	SCREW TAPTITE	1	TT3 PAN 3X10 MFZN	
49	4857024601	HEAT SINK	1	AL EX	
50	7271301011	SCREW TAPTITE	2	TT3 PAN 3X10 MFZN	
51	4857024900	HEAT SINK	1	AL EX	
52	7271301011	SCREW TAPTITE	1	TT3 PAN 3X10 MFZN	
53		MAIN PCB	1		CP=365
54	4857235600	SHIELD PLATE	1	SPTH-C T0.25	
55	4857235400	SHIELD CASE	1	SPTH-C T0.25	
56	4857235500	SHIELD CASE	1	SPTH-C T0.25	
57	4857024902	HEAT SINK	1	AL EX	
58	7271300811	SCREW TAPPING	1	T2S PAN 3X8 MFZN	

■ DTT-21C1

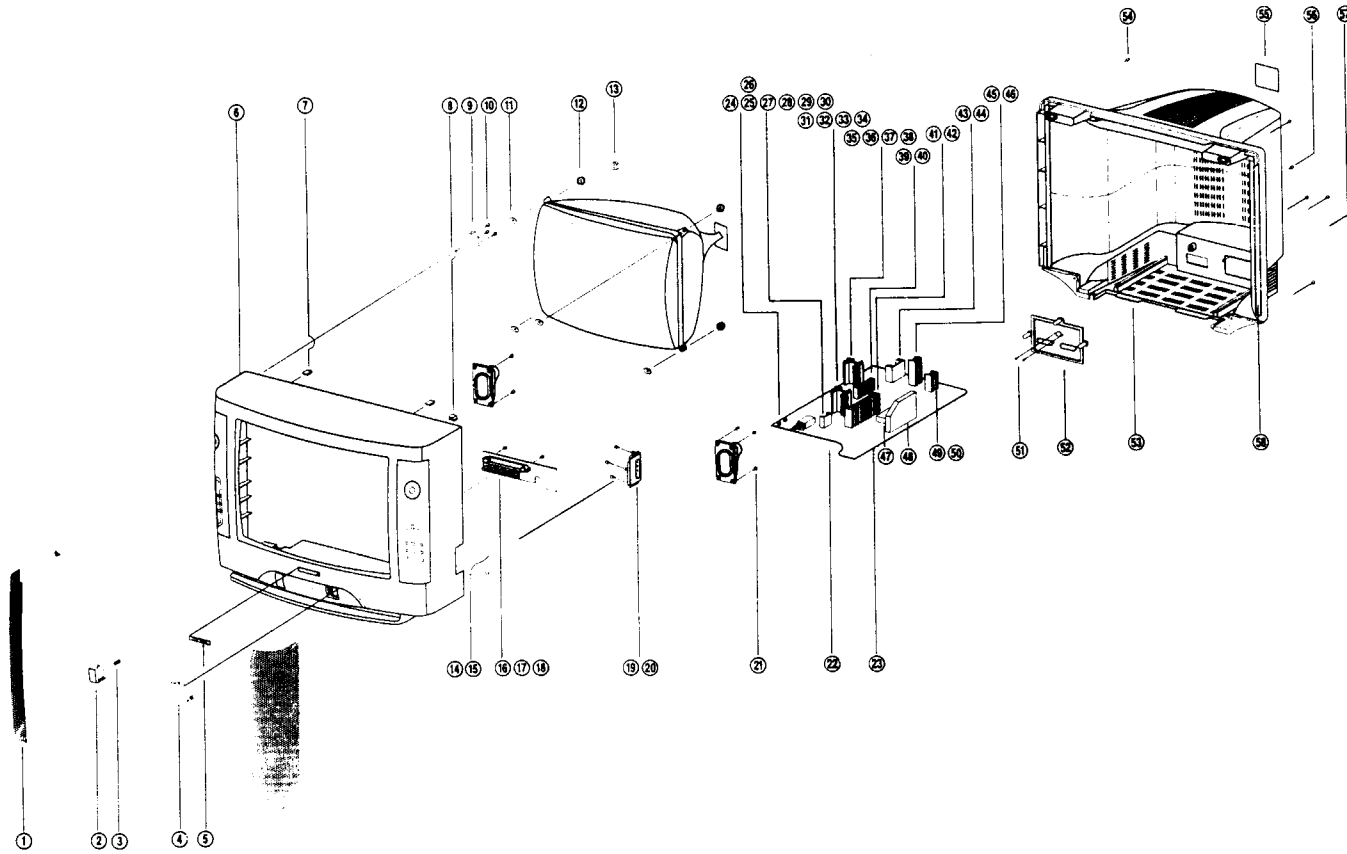

NO.	PART CODE	PART NAME	Q'TY	DESCRIPTION	REMARK
1	4852525200	GRILL	2	EGI TO 5+SPONGE	
2	4854837402	BUTTON POWER	1	ABS BK	
3	4856717900	SPRING	1	SWPA	
4	4855519001	DECO SENSOR	1	P C SMOG	
5	4855615900	MARK BRAND	1	A105OP-H24 T0.4	
6	4852047001	MASK FRONT	1	HIPS BK	
7	4853311601	RETAINER BACK	2	HIPS NC	
8	4853525501	HOLDER CORD	1	HIPS BY	
9	4853414401	BRKT CRT	4	ABS NC	
10	7121401411	SCREW TAPPING	12	T2S PAN 4X14 MFZN	
11	4856214800	WASHER RUBBER	4	CR	
12	4856213200	WASHER CRT FIX	4	SK-5 B.K T1.2	
13	7391500011	NUT HEX	4	6N-1-5 MFZN	
14	4851900120	GRILL GROUND AS	2	DS-W1007-PC5PCM	
15	7128301011	SCREW TAPPING	2	T2S WAS 3X10 MFZN	
16	4854920701	BUTTON	1	ABS BK	
17	7128301011	SCREW TAPPING	2	T2S WAS 3X10 MFZN	
18	4853528101	HOLDER	1	HIPS BK	
19	4852317601	PANEL AV	1	HIPS BK	
20	7128301011	SCREW TAPPING	3	T2S WAS 3X10	
21	7128301011	SCREW TAPPING	8	T2S WAS 3X10 MFZN	
22	9850136506	MAIN PCB AS	1		
23	4857235600	SHIELD PLATE	1	SPTH-C T0.25	
24	4857415001	FUSE CLIP	1	PFC5000-0702	
25	4857415001	FUSE CLIP	1	PFC5000-0702	
26	4857621200	INSU COVER	1	PVC T1.0Q4V-0	
27	4857025400	HEAT SINK	1	AL EX	
28	4856012310	SCREW SPECIAL	1	PAN 3X10 MFZN	
29	4856215200	WASHER	1	SPCC	
30	7392300011	NUT HEX	1	6N-2-3 MFZN	
31	4857024502	HEAT SINK	1	AL EX	
32	4856012312	SCREW SPECIAL	1	PAN 3X12 MFZN	
33	4856215201	WASHER	1	SPCC	
34	7392300011	NUT HEX	1	6N-2-3 MFZN	
35	4857024502	HEAT SINK	1	AL EX	
36	4856012312	SCREW SPECIAL	1	PAN 3X12 MFZN	
37	4856215201	WASHER	1	SPCC	
38	7392300011	NUT HEX	1	6N-2-3 MFZN	
39	4857024900	HEAT SINK	1	AL EX	
40	7271301011	SCREW TAPTITE	1	TT3 PAN 3X10 MFZN	
41	4857024405	HEAT SINK	1	AL EX	
42	7271301011	SCRES TAPTITE	1	TT3 PAN 3X10 MFZN	
43	4857024601	HEAT SINK	1	AL EX	
44	7271301011	SCRES TAPTITE	2	TT3 PAN 3X10 MFZN	
45	4857024900	HEAT SINK	1	AL EX	
46	7121260811	SCREW TAPPING	1	T2S PAN 3X8 MFZN	
47	4857235400	SHIELD CASE	1	SPTH-C T0.25	
48	4857235500	SHIELD CASE	1	SPTH-C T0.25	
49	4857024902	HEAT SINK	1	AL EX	
50	7121300611	SCREW TAPPING	1	T2S PAN 3X8 MFZN	
51	7128261011	SCREW TAPPING	2	T2S WAS S.6X10 MFZN	
52	4853624802	TERMINAL ANT	1	HIPS BK	
53	4852134500	COVER BACK	1	FR HIPS BK	
54	7122401411	SCREW TAPPING	4	T2S TRS 4X14 MFZN	
55	4855415800	SPEC PLATE	1	150ART P/E FILM	
56	7122401411	SCREW TAPPING	1	T2S TRS 4X14 MFZN	BC+FBT
57	7122401411	SCREW TAPPING	3	T2S TRS 4X14 MFZN	BC+TERM
58	4857817610	CLOTH BLACK	2	FELT T0.7 L=300	

CHASSIS

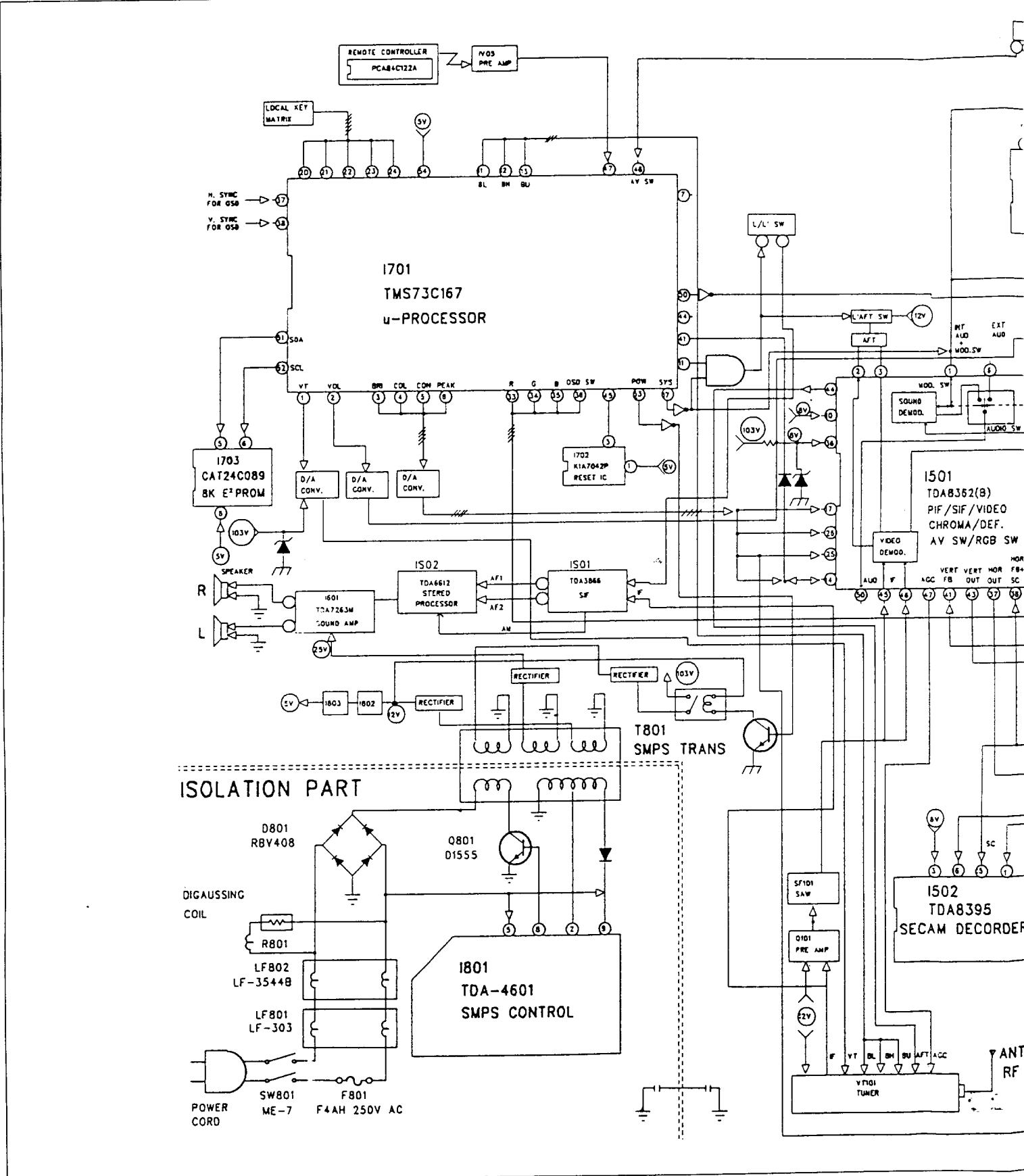

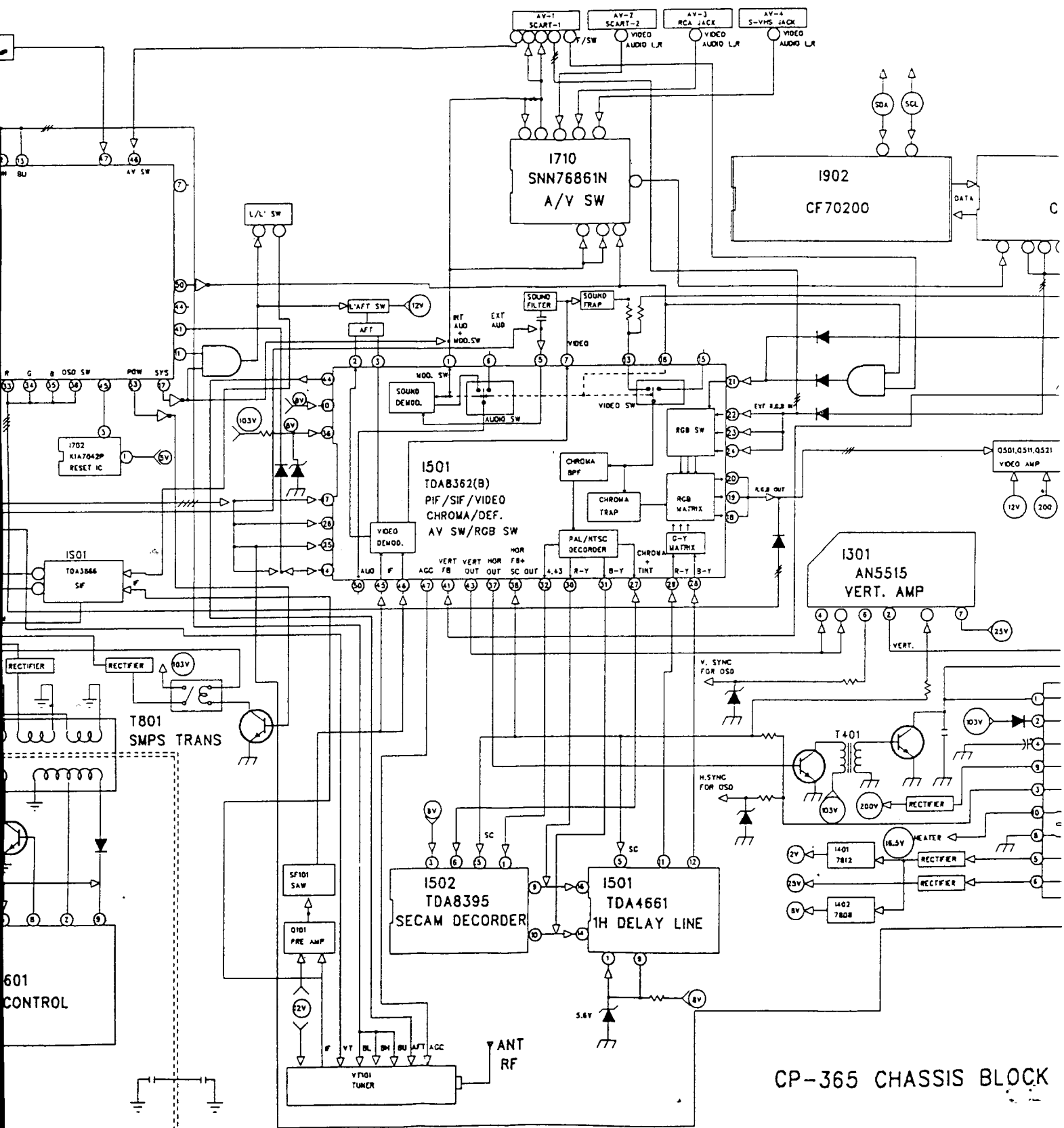

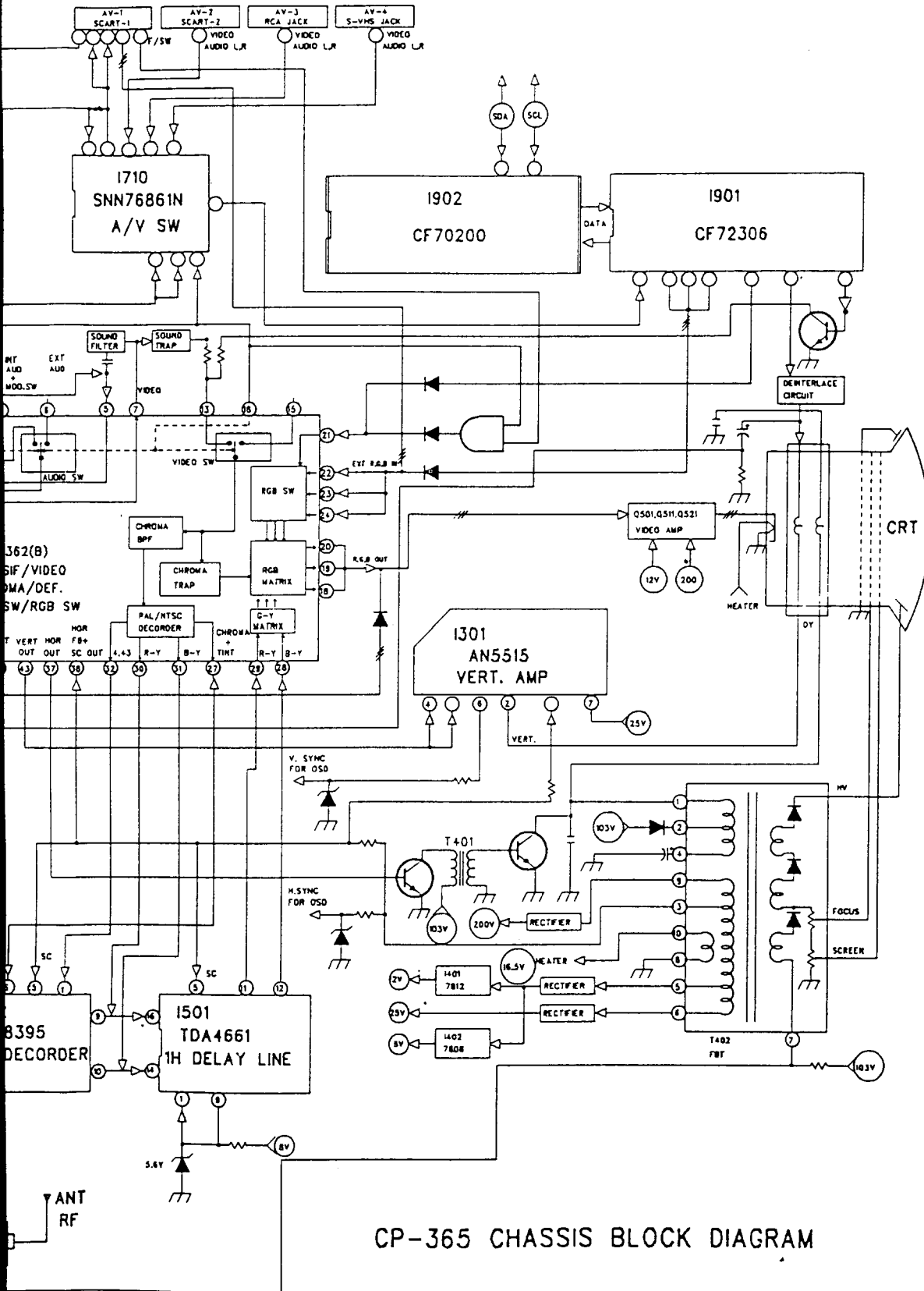

CP-365 CHASSIS BLOCK DIAGRAM

CHASSIS : CP-365

SCHEMATIC DIAGRAM

* PAL/SECAM - B/G (FTZ)

* PAL/SECAM - B/G. D/K

NTSC - 3.58/4.43 (AV)

* PAL/SECAM - B/G.

SECAM -L/L'

* PAL - B/G

* PAL - I

WAVE FORMS

INPUT SIGNAL : PAL SYSTEM

VIDEO : 8 STEP COLOR BAR 87.5% AM
AUDIO : 1KHz SINE WAVE 60% FM

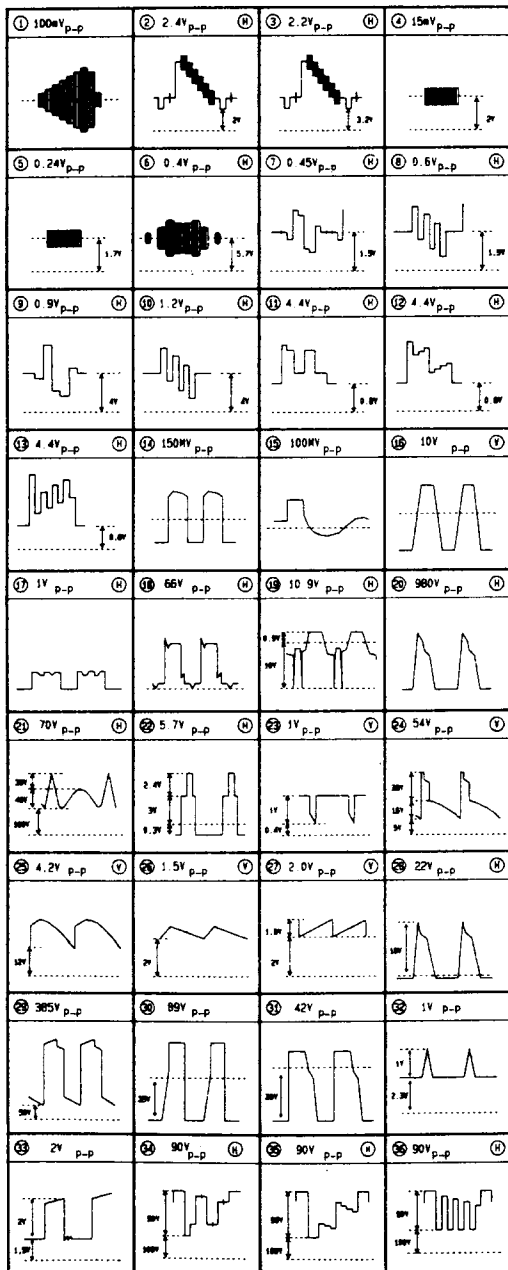

- THE UNITS OF RESISTANCE "OHM" IS OMITTED.
(K = 1000 OHMS M = 1000000 OHMS)
- ALL RESISTORS ARE 1/6 WATT UNLESS OTHERWISE NOTED.
- CAPACITANCE VALUES 1.0 AND ABOVE ARE IN PF THOSE BELOW ARE IN UF EXCEPT AS INDICATED.
(uF = 1000000 pF)
- INDUCTIVE VALUES ARE IN uH EXCEPT AS INDICATED.
- ALL DIODE ARE 1N4148 EXCEPT AS INDICATED.
- ALL NPN TRANSISTOR ARE KTC3198Y ALL PNP TRANSISTOR ARE KTA1266Y EXCEPT AS INDICATED.
- DC VOLTAGE AND AC WAVEFORM MEASUREMENT CONDITIONS.

ALL THE VOLTAGES IN EACH POINT ARE MEASURED UNDER THE STANDARD COLOUR BAR SIGNAL INPUT (5 CHANNEL) AND ALL CONTROLS SET TO THE MAXIMUM POSITION.

(DC VOLTAGES WITH VTMV AND AC WAVEFORMS WITH OSCILLOSCOPE)

(FOR A NOMINAL LINE VOLTAGE : AC 230V 50Hz)
- SINCE THIS SCHEMATIC DIAGRAM IS A STANDARD ONE THE CIRCUIT AND CIRCUIT CONSTANTS MAY BE SUBJECT TO CHANGE FOR IMPROVEMENT WITHOUT ANY NOTICE.

SAFETY CAUTION :

BEFORE SERVICING THIS CHASSIS IT IS IMPORTANT THAT THE SERVICE TECHNICIAN READ AND FOLLOW THE "X-RAY RADIATION PRECAUTION" "SAFETY PRECAUTIONS" AND "PRODUCT SAFETY NOTICE" IN THE SERVICE MANUAL.

PRODUCT SAFETY NOTE :

SHADED COMPONENTS ARE IMPORTANT FOR MAINTAINING THE SAFETY OF THE SET AND SHOULD BE REPLACED ONLY WITH TYPES IDENTICAL TO THOSE IN THE ORIGINAL OR SPECIFIED ONE IN THE PARTS LIST.
DON'T DEGRADE THE SAFETY OF THE SET THROUGH IMPROPER SERVICING.

RESISTOR

CARBON FILM		
M-OXIDE FILM		(M)
CARBON COMP		(CC)
FUSIBLE		(F)
CEMENT		(C)

CAPACITOR

ELECTRO		
CERAMIC		
CERAMIC CH		(CH)
TANTAL		(T)
ELECTRO NONPOLAR		(NP)
MYLAR		(M)

COIL

PEAKING		
CHOKER		(C)
BEAD		(B)

DIFFERENT PART FOR SYSTEM

NO.	LDC.	P/S-B/G (FTZ) [TF]	P-B/G [TS]	P.
1	VT101	TEKE4-073A	←	
2	SF101	G3962M	←	
3	SFS01	G9251M	G9251M (NICAM)	
4	SFS02			
5	I503			
6	I501	TDA-8362B	TDA-8362B	
7	P801A	CW-4232	KKP-419C	
8	I504			
9	X502			
10	R456	1W 47K	1W 47K	
11	JW01			WI
12	VC101			
13	J233			
14	J234			
15	J256	JUMPER		
16	J282		JUMPER	
17	D746		1N4148	
18	D748			
19	D738			
20	D743	1N4148	←	
21	D744	1N4148	←	
22	M722	SPTH-C TD.3		
23	D750			
24	D741			
25	C105	10uF	10uF	
26	4000	2C	NICAM+2C	
27	C106	10uF	10uF	

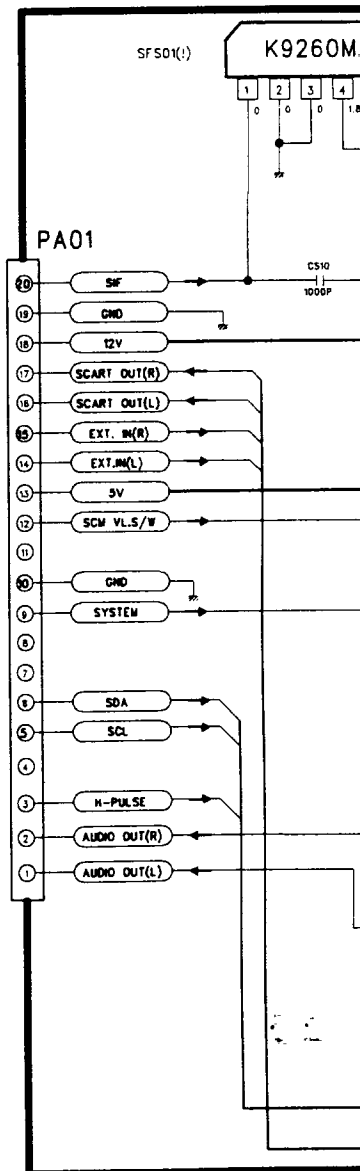

DIFFERENT PART FOR SYSTEM (!)

DIFFERENT PART FOR SIZE (!)

OHM^Ω IS OMITTED.
 00 OHMS)
 * UNLESS
 10 ABOVE ARE IN OF
 SEPT AS INDICATED.
 1 EXCEPT AS INDICATED.
 4 EXCEPT AS INDICATED.
 103198Y ALL PNP TRANSISTOR
 INDICATED.
 2M MEASUREMENT CONDITIONS.
 4 POINT ARE MEASURED
 OR BAR SIGNAL INPUT
 CONTROLS SET TO THE
 AND AC WAVEFORMS
 TABLE : AC 230V 50Hz)
 1000Ω IS A STANDARD ONE
 CONSTANTS MAY BE SUBJECT TO
 WITHOUT ANY NOTICE.
 IS IT IS IMPORTANT THAT
 AND FOLLOW THE
 "SAFETY PRECAUTIONS"
 IN THE SERVICE MANUAL.

NO.	LOC.	P/S-B/G (FTZ) [TF]	P-B/G [TS]	P/S-B/G D/K N-3/4 (AV) [TK]	P/S-B/G D/K S-L/L' [VA]	P-I [TU]	REMARK
1	VT101	TEKE4-073A	←	VTSS7S23	TEKE4-073A	DET7BZ	
2	SF101	G3962M	←	←	←	J3950M	
3	SFS01	69251M	G9251M (NICAM)	K9260M	K9260M	J9250M	
4	SFS02				L9461M		
5	I503			TDA-8395	TDA-8395		
6	I501	TDA-8362B	TDA-8362B	TDA-8362B	TDA-8362	TDA-8362B	
7	PB01A	CW-4232	KKP-419C	KKP-419C	KKP-419C	CW-3201	
8	I504			LA-7950			N-3/4 (AV)
9	X502			3.58MHZ			N-3/4 (AV)
10	R456	1M 47K	1M 47K		1M 47K	1M 47K	N-4.43 (AV)
11	JW01			WIRE JUMPER			N-3/4 (AV)
12	VC101				T203R300B		S-L/L'
13	J233				JUMPER		S-L/L'
14	J234				JUMPER		S-L/L'
15	J256	JUMPER		JUMPER	JUMPER		2C
16	J282		JUMPER			JUMPER	2C+NICAM
17	D746		1N414B			1N414B	2C+NICAM
18	D748					1N414B	10F
19	D738				1N414B		S-L/L'
20	D743	1N414B	←	←	←	←	20+21=AV4
21	D744	1N414B	←	←	←	←	AV2
22	M722	SPTH-C TO.3					SHIELD PLATE
23	D750			1N414B			EAST
24	D741					1N414B	CHARACTER
25	C105	10uF	10uF	10uF	10uF	100uF	
26	4000	2C	NICAM+2C	2C	2C	NICAM+2C	STEREO MODULE
27	C106	10uF	10uF	10uF	33uF	10uF	

NO.	LOC.	20"			
		ORION	SAMSUNG	POLKOLOR	
1	CRT	A48JLL90	A48ECR11X16	A48EEV33X01	A5
2	CRT SOCKET	ISH-01	CTV3240-0501	CTV3240-0501	
3	D/CDIL	DC-2050	DC-2050	DC-2050	D
4	T402	DCF-2217J	FSA17013M	FSA26012M	DC
5	L402	L-102	L-62	L-76	
6	R414	2W 6.8 (F)	2W 2.7 (F)	2W 2.7 (F)	2W
7	GROUND ASSY	48519A2010	←	←	485
8	C407	1.6KV 6900	1.6KV 8200	1.6KV 7500	1.6
9	C408	2KV 1000	2KV 470	←	
10	C409	2000V 0.47	200V 0.15	200V 0.39	20
11	R801	PTH451C202 BG180N270	PTH451C202 BG180N270	PTH451C202 BG180N270	PTH BF

NOTE :
 IMPORTANT FOR MAINTAINING
 SHOULD BE REPLACED ONLY
 HOSE IN THE ORIGINAL OR
 S LIST.
 OF THE SET THROUGH

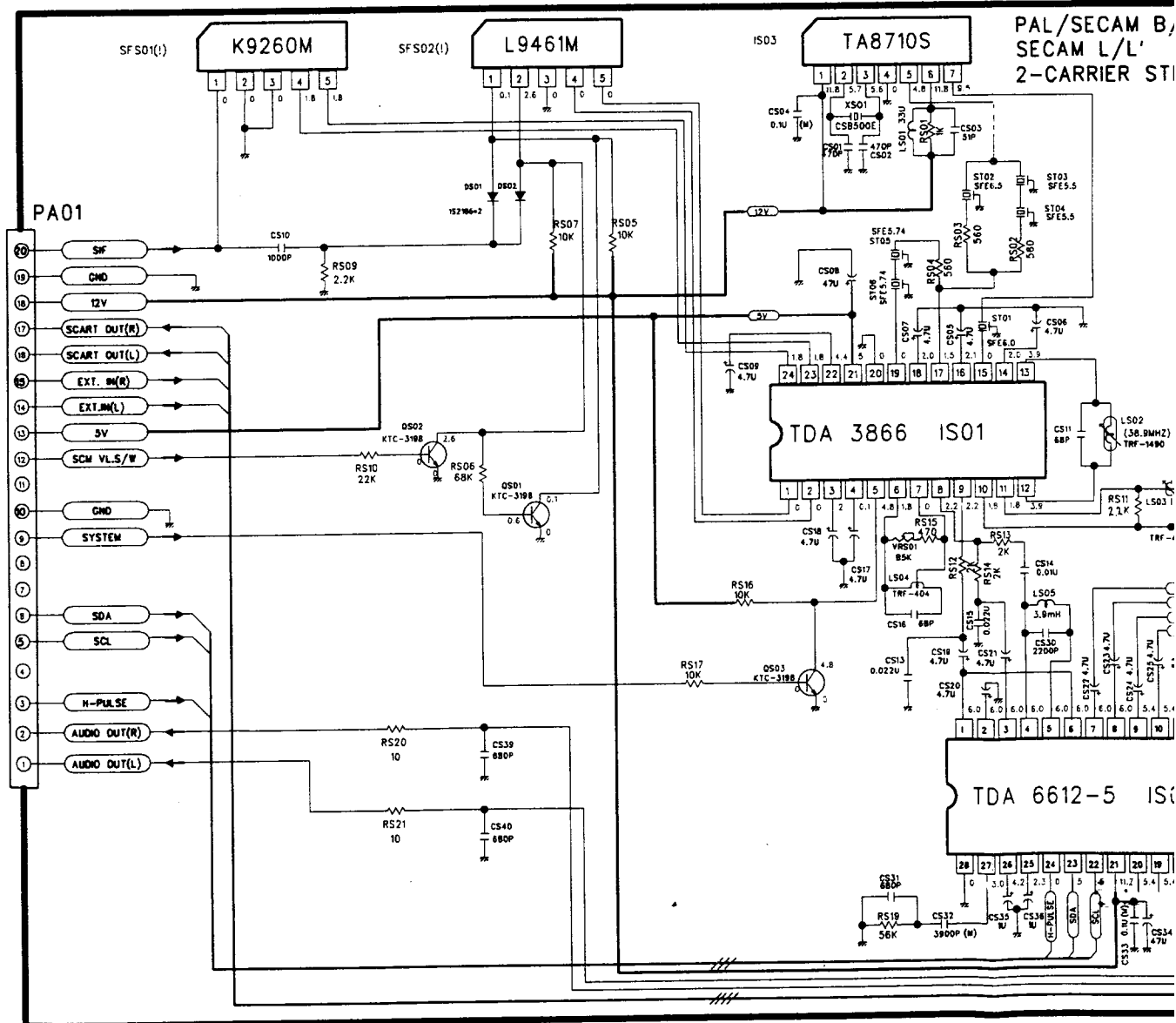
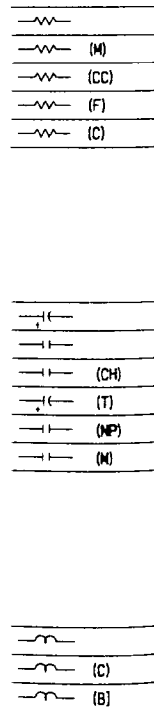

DIFFERENT PART FOR SIZE (!)

NO.	LOC.	20"			21"		
		ORION	SAMSUNG	POLKOLOR	ORION	PHILIPS	SAMSUNG
1	CRT	A4BULL90	A4BECR11X16	A4BEEV33X01	A51JSM90X	A51EAL55X01	A51EER11X40
2	CRT SOCKET	ISM-01	CTV3240-0501	CTV3240-0501	ISM-03	CTV3240-0501	CTV3240-0501
3	D/COTL	DC-2050	DC-2050	DC-2050	DC-2070	DC-2070	DC-2070
4	T402	DCF-2217J	FSA17013M	FSA26012M	DCF-2217L	FSA17013M	FSA17013M
5	L402	L-102	L-62	L-76	L-102	L-76	L-102
6	R414	2W 6.8 (F)	2W 2.7 (F)	2W 2.7 (F)	2W 6.8 (F)	2W 6.8 (F)	2W 6.8 (F)
7	GROUND ASSY	48519A2010	←	←	4851900410	←	←
8	C407	1.6KV 6900	1.6KV 8200	1.6KV 7500	1.6KV 8200	1.6KV 8200	1.6KV 8200
9	C408	2KV 1000	2KV 470	←	←	←	←
10	C409	2000V 0.47	200V 0.15	200V 0.39	200V 0.33	200V 0.47	200V 0.36
11	RB01	PTH451C202 BG180N270	PTH451C202 BG180N270	PTH451C202 BG180N270	PTH451C262 BF140M270	PTH451C262 BF140M270	PTH451C262 BF140M270

DIFFERENT PART FOR MODEL

LOC.	CRT
TS	ORION CRT
TSF	PHILIPS CRT. SAMSUNG WF CRT
TSP	POLKOLOR CRT

LOC.	INCH	HEAD PHONE JACK	CONTROL DOOR	INDEPENDENT CONTROL PCB
DTT-2195	21"	YES	NO	YES
DTT-21C1	21"	YES	NO	YES
DTT-21B1	21"	YES	NO	YES
DTT-2166	21"	NO	YES	NO
DTT-20C1	20"	NO	NO	YES
DTT-20B1	20"	NO	NO	YES
DTT-2066	20"	NO	YES	NO
DTT-2075	20"	NO	YES	NO

DIODE OPT

LOC.	DIODE OPT
D743/	X/X
D744	X/O
	O/X
	O/O
D745	X
	O
D747/	X/X
D740	X/O
	O/X
D739/	X/X
D750	X/O
	O/X
D749/	X/X
D748	O/X
	X/O
D741	O
	X
D738X	X
	O

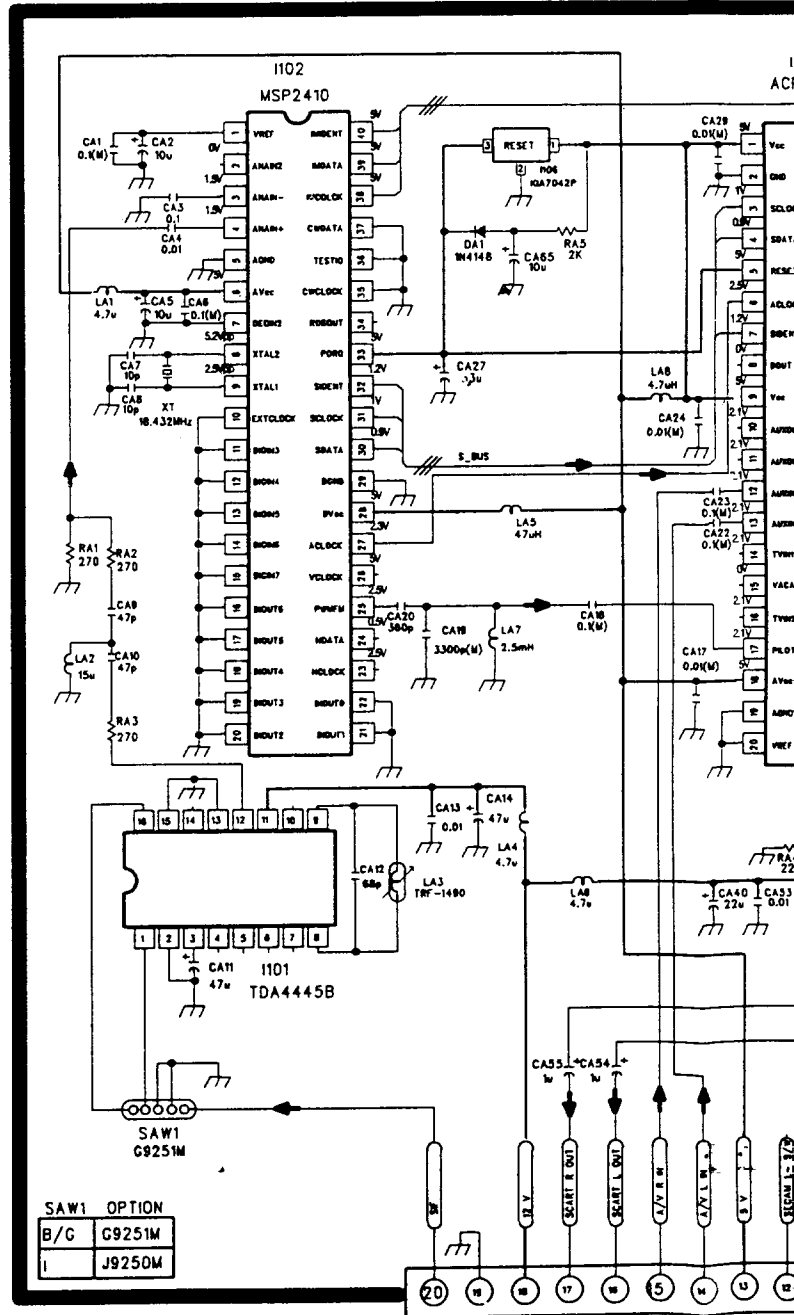
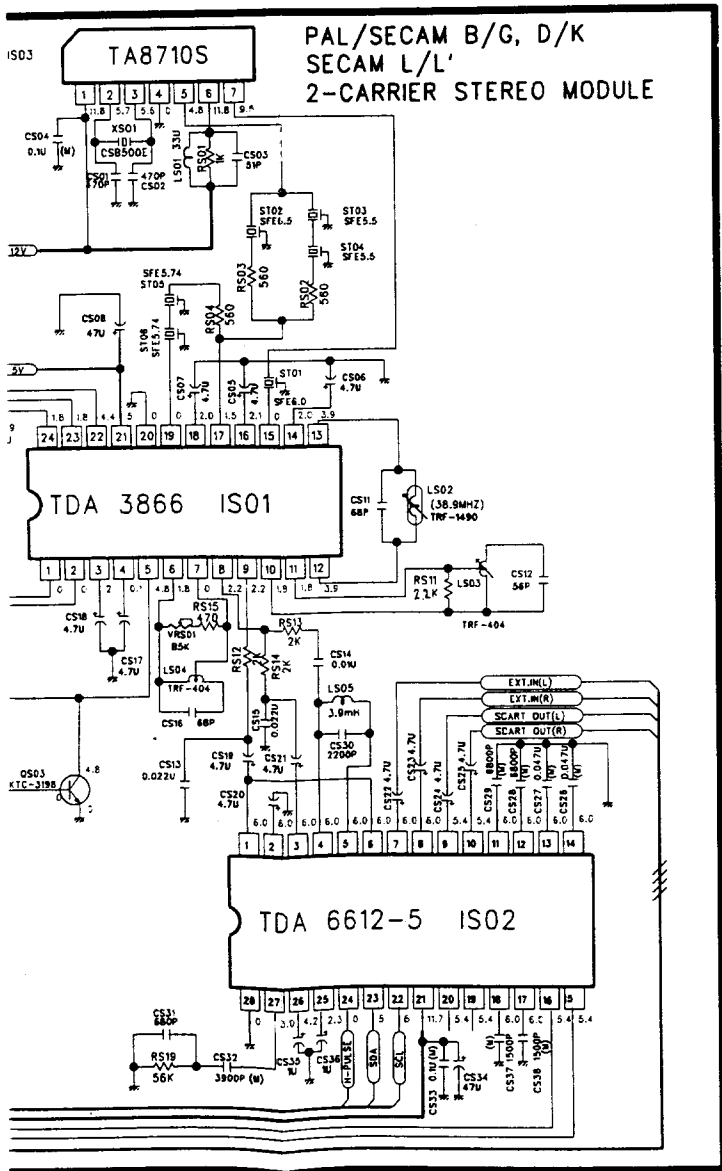

CRT		
RT		
CRT, SAMSUNG WF CRT		
CRT		
PHONE	CONTROL DOOR	INDEPENDENT CONTROL PCB
5	NO	YES
5	NO	YES
5	NO	YES
0	YES	NO
0	NO	YES
0	NO	YES
0	YES	NO
0	YES	NO

	X/X	3 AV SYSTEM
D743/	X/D	2 AV SYSTEM
D744	D/X	1 AV SYSTEM
	D/D	4 AV SYSTEM
D746	X	2-CARRIER
	0	NICAM & 2-CARRIER
	X/X	FLOT/TOP (8 PAGE)
D747/	X/O	NO TEXT
D740	D/X	FLOF (4 PAGE)
	X/X	WEST TEXT
D739/	X/O	EAST
D750	D/X	TURKISH
	X/X	THREE BAND
D749/	D/X	FOUR BAND
D748	X/O	LHF ONLY
	0	OSD BY CHARACTER
D741	X	OSD BY SYMBOL
	X	SINGLE SYSTEM
D738X	0	SECAM L/L'

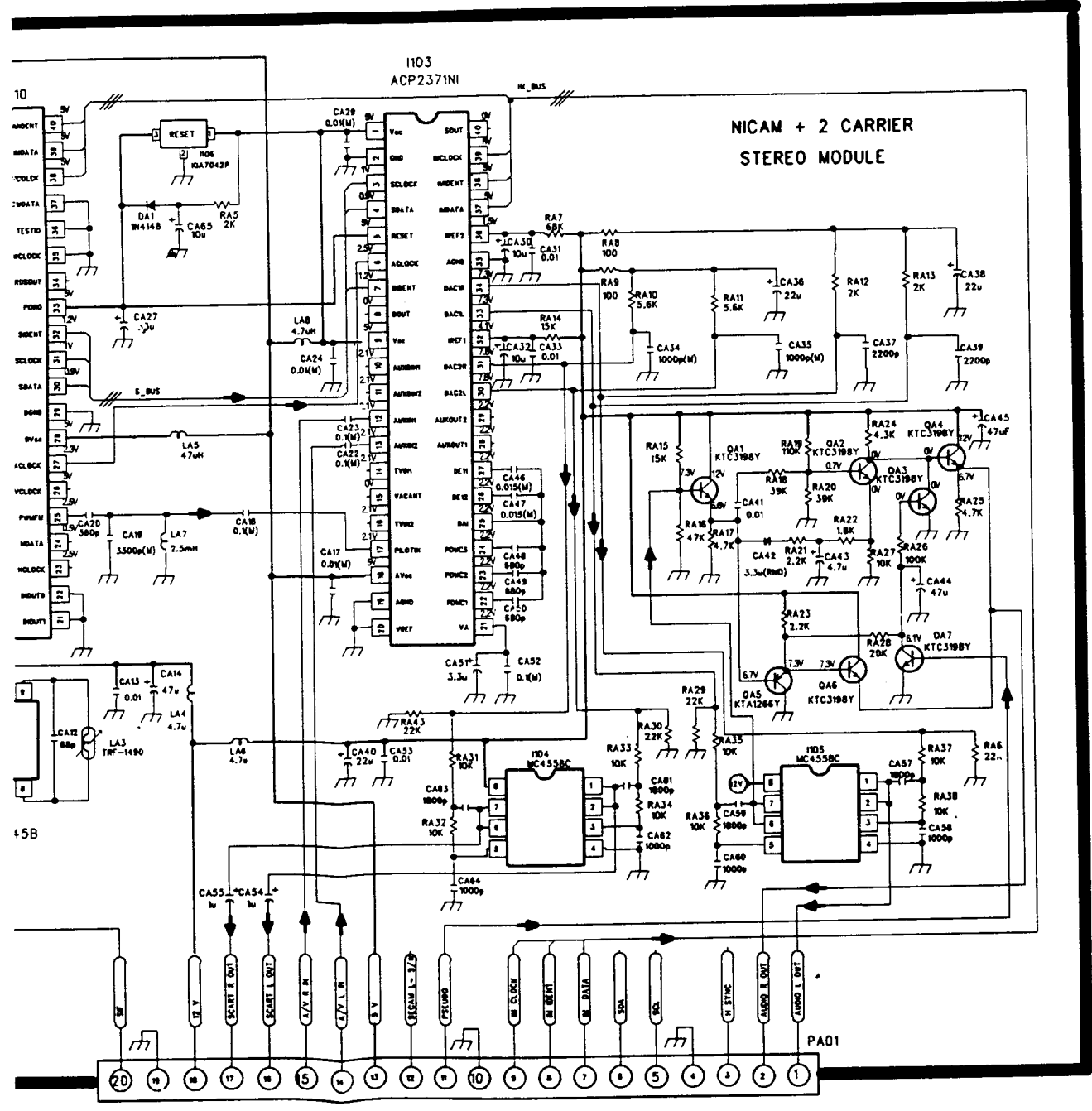

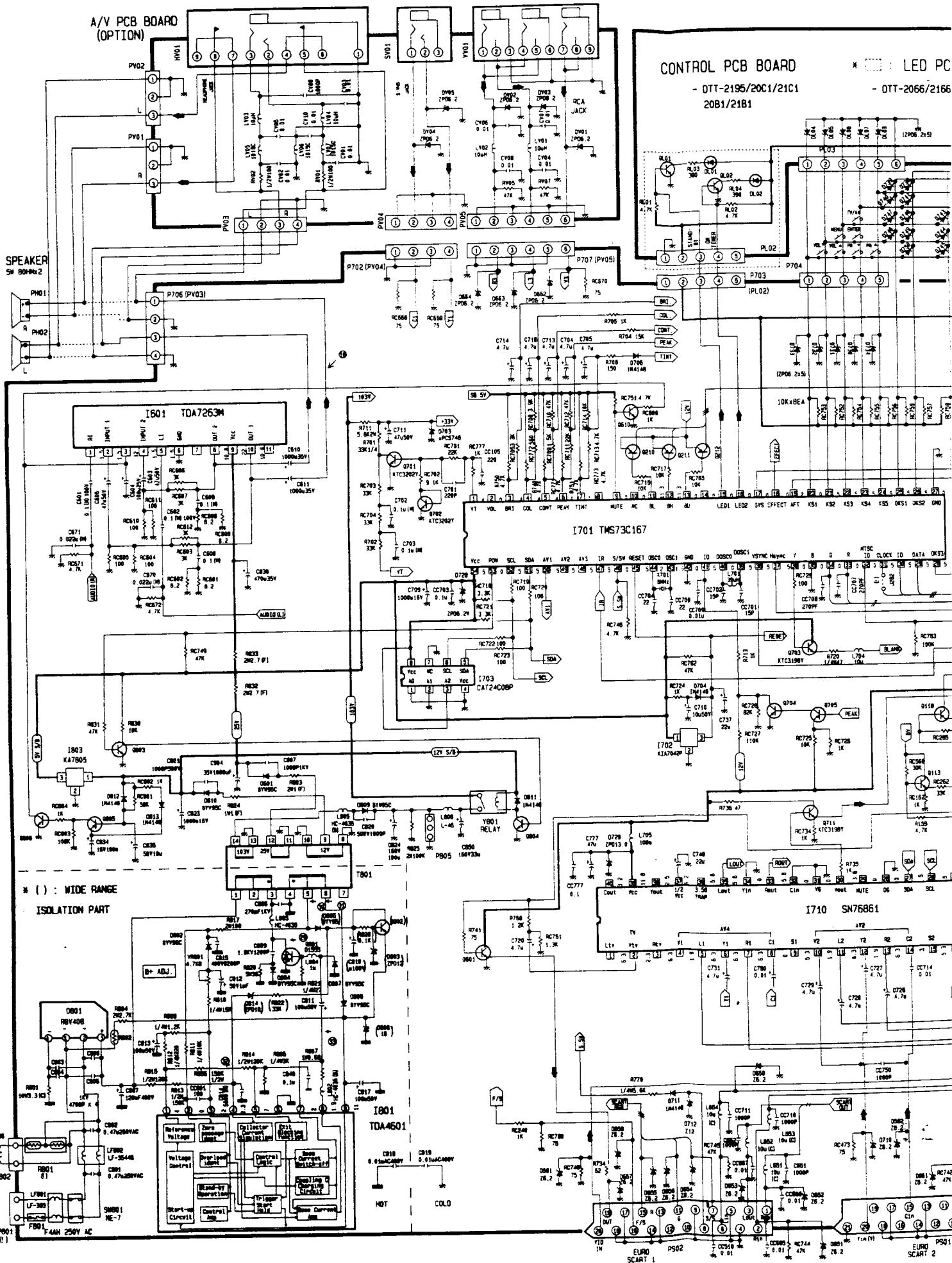

CHASSIS : CP-365 SCHEMATIC D

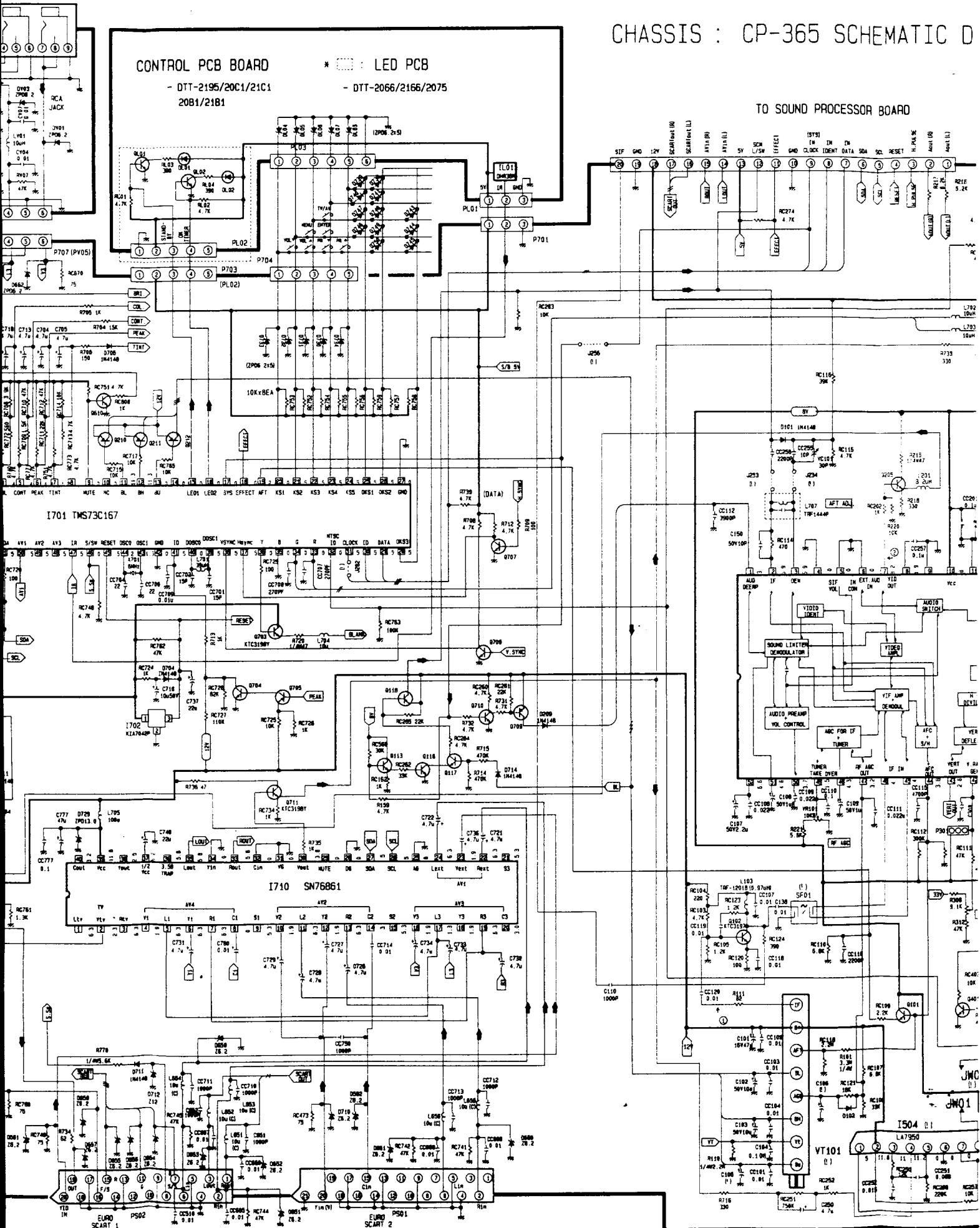

CP-365 SCHEMATIC DIAGRAM

TO SOUND PROCESSOR BOARD

P501 TO CRT BOARD

TELETEXT PART

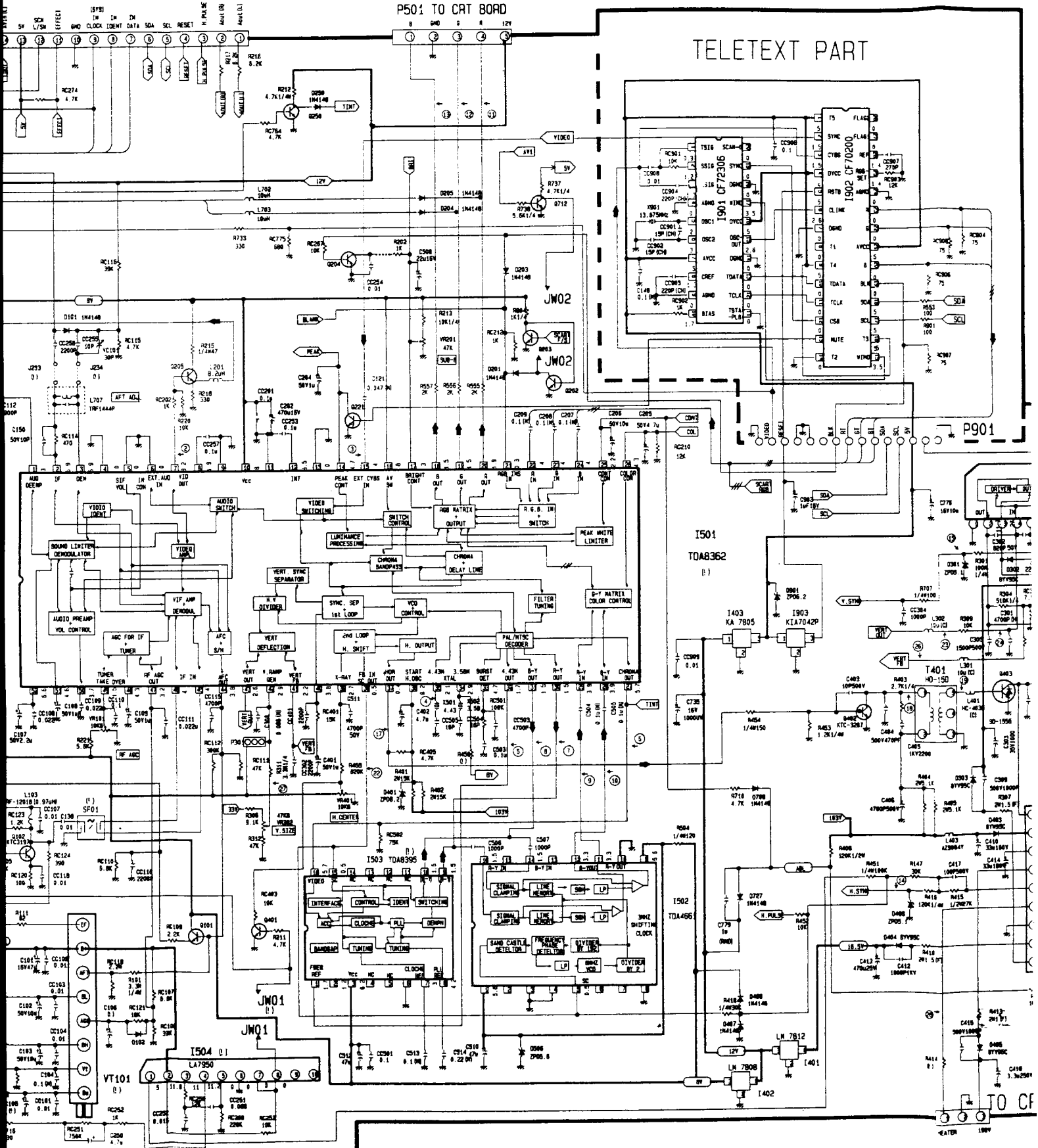

TELETEXT PART

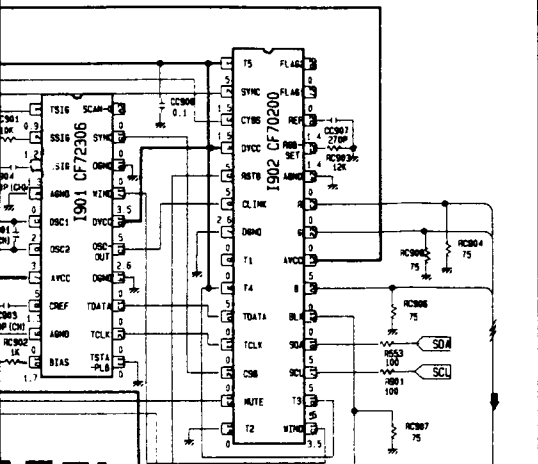

CRT BOARD

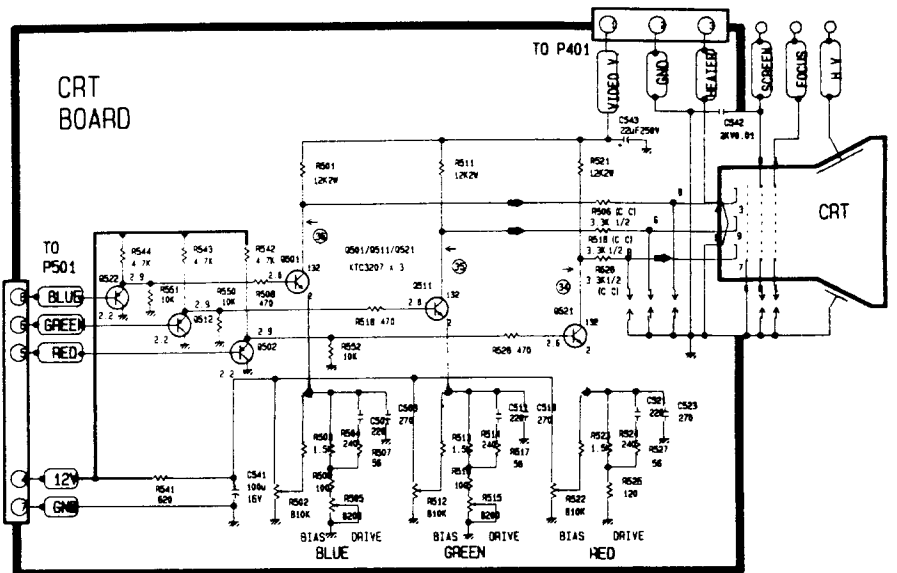

I501

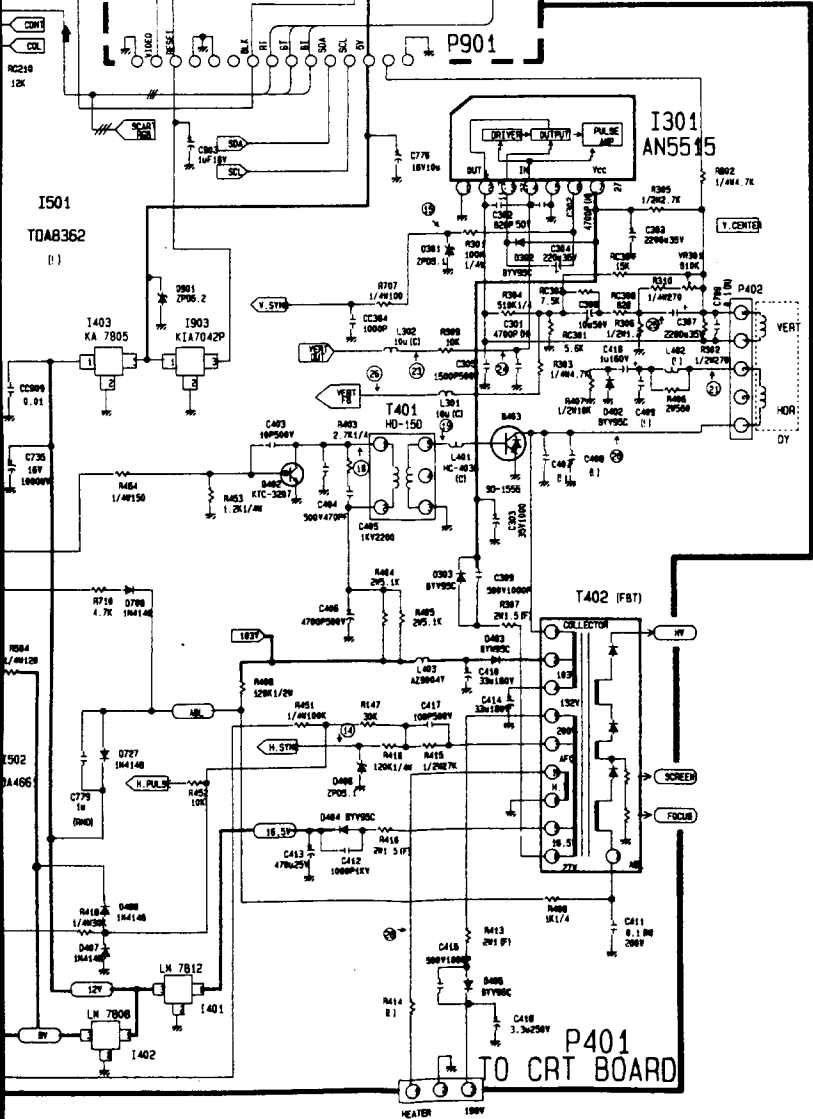

REMOTE CONTROL TRANSMITTER

