

DAEWOO

S/M No. : TWP895BEF0R2

Service Manual

Colour Television

CHASSIS

WP-895

WP-895F

CP-885

CP-885F

CP-485F



DAEWOO ELECTRONICS CO., LTD

[http : //svc.dwe.co.kr](http://svc.dwe.co.kr)

Jun. 2002

Contents

1 - Main features	4
1-1 Specifications	4
1-2 Channel table	8
1-3 ATSS sorting method	11
2 - Safety instruction	13
3 - Alignment instructions	14
3-1 Microcontroller configuration : Service mode	14
3-2 Service mode navigation	14
3-3 Microcontroller configuration : Option	15
3-4 TV set Alignment	16
3-4-1 Local oscillator alignment	16
3-4-2 G2 alignment	16
3-4-3 White balance	16
3-4-4 Focus	16
3-4-5 Vertical geometry	16
3-4-6 Horizontal picture centring	16
3-4-7 East/West correction	16
3-4-8 AGC	18
4 - IC description	19
4-1 VCT383xA TV signal processor - Teletext decoder with embedded 8 bit μ - Controller	19
4-1-1 Block diagram off the VCT	19
4-1-2 TV-signal Processor	19
4-1-2 μ -Controller	20
4-1-4 Teletext Features	20
4-1-5 Display OSD Features	21
4-1-6 Audio Features	21
4-1-7 General Features	21
4-1-8 Data Capture	21
4-1-9 Data Capture Features	21
4-1-10 TV processor version and μ -Controller capacity	22
4-1-11 IC marking and version	22
4-1-12 Pinning	22
4-2 MSP341x Multistandard Sound Processor	25
4-2-1 Basic Features of the MSP 341x	25
4-3 TDA4470 - Multistandard Video-IF and Quasi Parallel Sound Processor	29
4-3-1 Description	29
4-3-2 Features	29
4-3-3 Pinning	29
4-3-4 Block diagram	30
4-4 TDA894xJ Stereo Audio Amplifier	31
4-4-1 Features	31
4-5 TDA835xJ Vertical Amplifier	33
4-5-1 TDA8357J	33

4-5-2	TDA8358J	34
4-6	TDA6107Q	35
4-7	24C16 - 16 Kb EEPROM	38
4-8	STR - F6653	39
4-8-1	General description	39
4-8-2	Features	39
4-8-3	Block diagram	39
4-8-4	Pin description	40
4-8-5	Control part - electrical characteristics	40
4-8-6	MOSFET electrical characteristics	41
5	Circuit description	42
5-1	Block diagram	42
5-2	IF section	43
5-2-1	Block diagram	43
5-2-2	Vision IF Amplifier	43
5-2-3	Tuner-and VIF-ACG	44
5-2-4	FPLL, VCO and AFC	44
5-2-5	Video Demodulation and Amplifier	45
5-2-6	Sound IF Amplifier and SIF-AGC	45
5-2-7	Quasi-Parallel-Sound (QPS) Mixer	45
5-2-8	Standard Switch	45
5-2-9	L'Switch	45
5-2-10	Internal Voltage Stabiliser	45
5-3	Video - VCT description	46
5-3-1	Introduction	46
5-3-2	Video Front-end	46
5-3-3	Input Selector	46
5-3-4	Clamping	46
5-3-5	Automatic Gain Control	46
5-3-6	Digitally Controlled Clock Oscillator	46
5-3-7	Analogue Video Output	46
5-3-8	Adaptive Comb Filter (VCT3834A only)	47
5-3-9	Color Decoder	47
5-3-10	Horizontal Scaler	47
5-3-11	Video Sync Processing	48
5-3-12	Display Processing	48
5-3-13	Chroma Transient Improvement	48
5-3-14	Video Back-end	48
5-3-15	CRT Measurement and Control	49
5-3-16	Average Beam Current Limiter	49
5-3-17	Analogue RGB Insertion	49
5-3-18	Fast-Blank Monitor	49
5-3-19	Vertical and East/West Deflection	50
5-3-20	EHT Compensation	50
5-3-21	Reset Function	50
5-3-22	Standby and Power-On	50
5-4	Micro-controller	50

5-4-1	Introduction.....	50
5-4-2	CPU	50
5-4-3	μ -Controller I/O pin configuration and function	51
5-4-4	Tuning	51
5-4-5	Automatic Format switching and WSS	51
5-4-6	EXTERNAL source control logic.....	52
5-4-7	Over Current Protection.....	54
5-5	Teletext Display	54
5-6	Sound processing.....	55
5-6-1	Analogue sound IF-input section.....	55
5-6-2	Quadrature Mixers	55
5-6-3	Phase and AM discrimination.....	55
5-6-4	NICAM decoder.....	56
5-6-5	DSP section.....	56
5-6-6	Sound Mode switching.....	56
5-7	Sound amplification.....	56
5-7-1	Power amplifier.....	56
5-7-2	Mode selection.....	57
5-8	Vertical deflection.....	57
5-8-1	Flyback voltage.....	57
5-8-2	Protection.....	57
5-8-3	Guard circuit.....	57
5-8-4	Damping resistor.....	57
5-8-5	EASTWEST Amplifier (TDA8358J only).....	57
5-9	Power supply (STR F6653).....	58
5-9-1	STR-F6654 general description.....	58
5-9-2	Power supply primary part operations.....	58
5-10	TV start-up, TV normal run and stand by mode operations.....	62
5-10-1	TV start-up operations.....	62
5-10-2	TV normal run and stand-by mode operations.....	63
6	- Service parts list.....	68
7	- Exploded View	86
7-1	DWX-28W5	86
7-2	DWF-28W8	87
7-3	DTF-29U8	88
7-4	DTP-28A7	89
7-5	DTP-28B1	90
7-6	DTP-28G7	91
7-7	DTP-28G8	92
7-8	DWF-28W9	93
7-9	DTB-21U7	94
8	- PCB Layout	
9	- Circuit Diagram	

1- Main Features

1-1 Specifications

TV standard	PAL - SECAM B/G D/K, PAL I/I, SECAM L/L'
Sound system	NICAM B/G, I, D/K, L, FM 2Carrier B/G, D/K
Power consumption	21" Real Falt : 59 W approx. 28" 4:3, FST : 69 W approx. 29" 4:3, REAL FALT : 74 W approx. 28" 16:9, WIDE : 69 W approx.
Sound Output Power	21" : 4.5W x 2 (at 1kHz, 60% mod, 10%THD) 28", 29" : 7W x 2 (at 1kHz, 60% mod, 10%THD)
Speaker	21" : 7W 8 ohm x2 28", 29" : 12W 8 ohm x2
Teletext system	10 pages memory FASTEXT (FLOF or TOP)
Aerial input	75 ohm unbalanced
Channel coverage	Off-air channels, S-cable channels and hyperband
Tuning system	frequency synthesiser tuning system
Visual screen	21" : 51 cm 28" : 66 cm 29" : 68 cm
Channel indication	On Screen Display
Program Selection	100 programmes
Aux. terminal	EURO-SCART 1 : Audio / Video In and Out, R/G/B In, Slow and Fast switching. EURO-SCART 2 : Audio / Video In and Out, SVHS In. Monitor Out(option) AV3 : Audio-Video Jack on front of cabinet. Headphone jack (3.5 mm) on front of cabinet SVHS3 (option) : Jack on front of cabinet - sound input common with AV3.
Remote Control Unit	R-46G22

Specification matrix

CHASSIS NAME	WP-895 / CP-485F		WP-895F		CP885		CP885F	
VCT VERSION	3834		3834		3832		3834	
SOFTWARE VERSION	A		A		B		A	
REMOTE CONTROL	R46G22		R46G22		R46G22		R46G22	
PCB SERIAL NUMBER	4859805093		4859805193		4859805093		4859805193	
TUBE	16:09		16:9 REAL FLAT		4:03		4:3 REAL FLAT	
SVHS3	✓		✓				✓	
"PICTURE IMPROVEMENTS, COMB FILTER, HORIZONTAL SCALER"	✓		✓				✓	
TELETEXT SPLIT SCREEN	✓		✓				✓	
FORMATS AVAILABLE IN VIDEO MODE	AUTO / 4:3 / 14:9 / ZOOM 14:9 / ZOOM 16:9 / FULL SCREEN		AUTO / 4:3 / 14:9 / ZOOM 14:9 / ZOOM 16:9 / FULL SCREEN		AUTO / FULL SCREEN / 14:9 / 16:9		AUTO / FULL SCREEN / 14:9 / 16:9 / WATERGLASS	
AV2 MONITOR OUTPUT	✓		✓				✓	
MSP VERSION (OPTION)	3410	3411	3410	3411	3410	3415	3410	3411
SOUND EFFECTS	OFF / SPATIAL	OFF / SPATIAL / PANORAMA / VIRTUAL DOLBY	OFF / SPATIAL	OFF / SPATIAL / PANORAMA / VIRTUAL DOLBY	OFF / SPATIAL	OFF / SPATIAL	OFF / SPATIAL	OFF / SPATIAL / PANORAMA / VIRTUAL DOLBY
GRAPHIC EQUALIZER	✓	✓	✓	✓	✓		✓	✓
AV3 AUDIO INPUT	DEDICATED	DEDICATED	DEDICATED	DEDICATED	DEDICATED	AV2 COMMON	DEDICATED	DEDICATED
TELETEXT PAGE MEMORY	10 PAGE		10 PAGE		10 PAGE		10 PAGE	
TOP TELETEXT	AVAILABLE : SELECTABLE IN FACTORY/SERVICE MODE BY OPTION BITS							
FLOF TELETEXT	AVAILABLE : SELECTABLE IN FACTORY/SERVICE MODE BY OPTION BITS							
TEXT CHARACTER SUPPORT	"Pan-European Latin, Cyrillic, Greek"							
OSD LANGUAGES	"English, French, German, Italian, Spanish, Dutch, Danish, Finnish, Norwegian, Swedish, Greek, Polish, Hungarian, Czech, Slovakian, Romanian, Russian."							
TUNER OPTIONS	"Philips, Alps, Partsnic"							

21 Pin EURO-SCART 1 :

Pin	Signal Description	Matching value
1	Audio Output Right	0.5 Vrms, Impedance < $k\Omega$, (RF 54% Mod)
2	Audio Input Right	0.5 Vrms, Impedance > $10 k\Omega$
3	Audio Output Left	0.5 Vrms, Impedance < $k\Omega$, (RF 54% Mod)
4	Audio Earth	
5	Blue Earth	
6	Audio Input Left	0.5 Vrms, Impedance > $10 k\Omega$
7	Blue Input	0.7 Vpp \pm 0.1V, Impedance 75Ω
8	Slow Switching	TV : 0 to 2V, AV 16/9 : 4.5 to 7V, AV 4/3 : 9.5 to 12V , Impedance > $10 k\Omega$
9	Green Earth	
10	N.C.	
11	Green Input	0.7 Vpp \pm 0.1V, Impedance 75Ω
12	N.C.	
13	Red Earth	
14	Blanking Earth	
15	Red Input	0.7 Vpp \pm 0.1V, Impedance 75Ω
16	Fast Switching	0 to 0.4V : Logic "0", 1 to 3V : Logic "1", Impedance 75Ω
17	Video Out Earth	
18	Video In Earth	
19	Video Output	1 Vpp \pm 3dB, Impedance 75Ω
20	Video Input	1 Vpp \pm 3dB, Impedance 75Ω
21	Common Earth	

21 Pin EURO-SCART 2 :

Pin	Signal Description	Matching value
1	Audio Output Right	0.5 Vrms, Impedance < $1 k\Omega$, (RF 54% Mod) - Not available for cp885
2	Audio Input Right	0.5 Vrms, Impedance > $10 k\Omega$
3	Audio Output Left	0.5 Vrms, Impedance < $1 k\Omega$, (RF 54% Mod) - Not available for cp885
4	Audio Earth	
5	Earth	
6	Audio Input Left	0.5 Vrms, Impedance > $10 k\Omega$
7	N.C.	
8	Slow Switching	TV: 0 to 2V, AV 16:9: 4.5V to 7V, AV 4:3: 9.5 to 12V
9	N.C.	
10	N.C.	
11	N.C.	
12	N.C.	
13	Earth	
14	Earth	
15	Chroma Input	\pm 3dB for a luminance signal of 1 Vpp
16	N.C.	
17	Earth	
18	Video In Earth	

19	Video Output	1 Vpp ± 3dB, Impedance 75 Ω (Monitor output) - Not available for cp885
20	Video Input, Y In.	1 Vpp ± 3dB, Impedance 75 Ω
21	Common Earth	

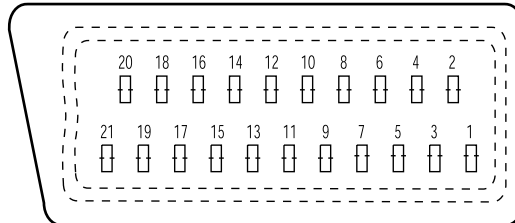

1-2 Channel table

FREQUENCY TABLE

CH	EUROPE CCIR	FRANCE	GB(IRELAND)	EAST OIRT
C01	46.25	-	47.75	49.75
C02	48.25	55.75 (L')	53.75	59.25
C03	55.25	60.5 (L')	61.75	77.25
C04	62.25	63.75 (L')	175.25	85.25
C05	175.25	176.00	183.25	93.25
C06	182.25	184.00	191.25	175.25
C07	189.25	192.00	199.25	183.25
C08	196.25	200.00	207.25	191.25
C09	203.25	208.00	215.25	199.25
C10	210.25	216.00	223.25	207.25
C11	217.25	189.25 (LUX)	231.25	215.25
C12	224.25	69.25 (L')	239.25	223.25
C13	53.75	76.25 (L')	247.25	-
C14	-	83.25 (L')	49.75	-
C15	82.25	90.25	57.75	-
C16	-	97.25	65.75	-
C17	183.75	-	77.75	-
C18	192.25	-	85.75	-
C19	201.25	-	-	-
C20	-	-	-	-
C21	471.25	471.25	471.25	471.25
C22	479.25	479.25	479.25	479.25
C23	487.25	487.25	487.25	487.25
C24	495.25	495.25	495.25	495.25
C25	503.25	503.25	503.25	503.25
C26	511.25	511.25	511.25	511.25
C27	519.25	519.25	519.25	519.25
C28	527.25	527.25	527.25	527.25
C29	535.25	535.25	535.25	535.25
C30	543.25	543.25	543.25	543.25
C31	551.25	551.25	551.25	551.25
C32	559.25	559.25	559.25	559.25
C33	567.25	567.25	567.25	567.25
C34	575.25	575.25	575.25	575.25
C35	583.25	583.25	583.25	583.25
C36	591.25	591.25	591.25	591.25
C37	599.25	599.25	599.25	599.25
C38	607.25	607.25	607.25	607.25
C39	615.25	615.25	615.25	615.25
C40	623.25	623.25	623.25	623.25
C41	631.25	631.25	631.25	631.25

CH	EUROPE CCIR	FRANCE	GB(IRELAND)	EAST OIRT
C42	639.25	639.25	639.25	639.25
C43	647.25	647.25	647.25	647.25
C44	655.25	655.25	655.25	655.25
C45	663.25	663.25	663.25	663.25
C46	671.25	671.25	671.25	671.25
C47	679.25	679.25	679.25	679.25
C48	687.25	687.25	687.25	687.25
C49	695.25	695.25	695.25	695.25
C50	703.25	703.25	703.25	703.25
C51	711.25	711.25	711.25	711.25
C52	719.25	719.25	719.25	719.25
C53	727.25	727.25	727.25	727.25
C54	735.25	735.25	735.25	735.25
C55	743.25	743.25	743.25	743.25
C56	751.25	751.25	751.25	751.25
C57	759.25	759.25	759.25	759.25
C58	767.25	767.25	767.25	767.25
C59	775.25	775.25	775.25	775.25
C60	783.25	783.25	783.25	783.25
C61	791.25	791.25	791.25	791.25
C62	799.25	799.25	799.25	799.25
C63	807.25	807.25	807.25	807.25
C64	815.25	815.25	815.25	815.25
C65	823.25	823.25	823.25	823.25
C66	831.25	831.25	831.25	831.25
C67	839.25	839.25	839.25	839.25
C68	847.25	847.25	847.25	847.25
C69	855.25	855.25	855.25	855.25
C70	863.25	863.25	863.25	863.25
C71	69.25	-	-	-
C72	76.25	-	-	-
C73	83.25	-	-	-
C74	90.25	-	-	-
C75	97.25	-	-	-
C76	59.25	-	-	-
C77	93.25	-	-	-
S01	105.25	104.75	103.25	105.25
S02	112.25	116.75	111.25	112.25
S03	119.25	128.75	119.25	119.25
S04	126.25	140.75	127.25	126.25
S05	133.25	152.75	135.25	133.25
S06	140.25	164.75	143.25	140.25
S07	147.25	176.75	151.25	147.25
S08	154.25	188.75	159.25	154.25
S09	161.25	200.75	167.25	161.25

CH	EUROPE CCIR	FRANCE	GB(IRELAND)	EAST OIRT
S10	168.25	212.75	-	168.25
S11	231.25	224.75	-	231.25
S12	238.25	236.75	-	238.25
S13	245.25	248.75	255.25	245.25
S14	252.25	260.75	263.25	252.25
S15	259.25	272.75	271.25	259.25
S16	266.25	284.75	279.25	266.25
S17	273.25	296.75	287.25	273.25
S18	280.25	136.00	295.25	280.25
S19	287.25	160.00	303.25	287.25
S20	294.25	-	-	294.25
S21	303.25	303.25	-	303.25
S22	311.25	311.25	311.25	311.25
S23	319.25	319.25	319.25	319.25
S24	327.25	327.25	327.25	327.25
S25	335.25	335.25	335.25	335.25
S26	343.25	343.25	343.25	343.25
S27	351.25	351.25	351.25	351.25
S28	359.25	359.25	359.25	359.25
S29	367.25	367.25	367.25	367.25
S30	375.25	375.25	375.25	375.25
S31	383.25	383.25	383.25	383.25
S32	391.25	391.25	391.25	391.25
S33	399.25	399.25	399.25	399.25
S34	407.25	407.25	407.25	407.25
S35	415.25	415.25	415.25	415.25
S36	423.25	423.25	423.25	423.25
S37	431.25	431.25	431.25	431.25
S38	439.25	439.25	439.25	439.25
S39	447.25	447.25	447.25	447.25
S40	455.25	455.25	455.25	455.25
S41	463.25	463.25	463.25	463.25

1-3 ATSS sorting method

The TV set sweeps all the TV bands from beginning of VHF to end of UHF. The TV controlling software for each program checks if a VPS CNI code is transmitted (this system exists for German, Swiss and Austrian transmissions). If no VPS CNI code is found then the system check if a CNI code is transmitted as part of the teletext transmission (Packet 8/30 format 1). If such a code (VPS or teletext) is found and if this code is in the ATSS list, the program is automatically named.

If the transmission does not have VPS CNI, and no teletext service is available, then there is no possibility of the program being automatically named.

The programs found are then sorted in 4 groups :

Group I : It contains all the programs from the selected country and named by the TV controlling software. Within this group the sorting order is fixed by the ATSS list.

Group II : It contains all the programs with a strong signal strength which are not listed in group I.

Group III : It contains all the programs with a weak signal strength which are not listed in group I.

Group IV : If two or more programs with the same code are found, only the strongest (or if they have the same level the one with the lowest frequency) is listed in group I, II or III. The others are listed in group IV.

Program number	Group	Skip
1	Group I	
2		
...		
n		
n+1	Group II	
...		
m		
m+1		
...	Group III	
p		
p+1		
...		
q	Group IV	✓
q+1		
...		
99		
0	not used	✓
...		
99		
0		

Program number	Group	Skip
1	Group II	
...		
m		
m+1	Group III	
...		
p		
p+1	Group IV	✓
...		
q		
q+1	not used	✓
...		
99		
0		

Special case : **Country selection = Others**

Special case : **France**

Note : If two programs with the same name but a different code are found these two programs are listed in group I, II or III (e.g. Regional program SW3 in Germany).

The sorting order within group II, III, and IV is based on the channel frequency. The Program with the lowest frequency is allocated the first rank in its group, and so forth until the last program of the group which has the highest frequency.

Special case : France

If France is selected, the TV controlling software first sweeps all TV bands with France system selected (positive video modulation) and then a second time with Europe system selected (negative video modulation).

Special case : Switzerland

If Switzerland is selected the TV controlling software first sweeps all TV bands with Europe system selected (negative video modulation) and then a second time with France system selected (positive video modulation).

Special case : GB

Note for satellite receiver users : Before starting ATSS turn On your satellite receiver and tune " SKY NEWS ". If GB is selected the TV controlling software seeks for programs only in UHF (C21 to C70).

The sorting order is :

- 1 - BBC1
- 2 - BBC2
- 3 - ITV
- 4 - CH4
- 5 - CH5
- 6 - NEWS

If two or more " identical" programs (same name but different code e.g. BBC1 and BBC1 Scotland) are found the following programs in the list will be shifted up. (1 - BBC1, 2 - BBC1, 3 - BBC2, 4 -ITV, 5 - CH4, 6 - CH5, 7 - NEWS, ..)

If one of the program above is not found, the associated program number remains empty (freq.=467.25 Mhz - Skip selected - no name - system=GB).

example A : 1 - BBC1, 2 - BBC2, 3 - ITV , 4 - ----, 5 - CH5, 6 - NEWS , ...

example B (if 2 BBC1 found) : 1 - BBC1, 2 - BBC1, 3 - BBC2, 4 - IT V, 5 - ----, 6 - CH5, 7 -NEWS, ...

2 - Safety instruction

WARNING: Only competent service personnel may carry out work involving the testing or repair of this equipment.

X-RAY RADIATION PRECAUTION

1. Excessive high voltage can produce potentially hazardous X-RAY RADIATION. To avoid such hazards, the high voltage must not exceed the specified limit. The nominal value of the high voltage of this receiver is 26 KV (21" - 29") at max beam current. The high voltage must not, under any circumstances, exceed 29.5 KV (21" - 25") or 30 KV (28" - 29"). Each time a receiver requires servicing, the high voltage should be checked. It is important to use an accurate and reliable high voltage meter.
2. The only source of X-RAY Radiation in this TV receiver is the picture tube. For continued X-RAY RADIATION protection, the replacement tube must be exactly the same type tube as specified in the parts list.

SAFETY PRECAUTION

1. Potentials of high voltage are present when this receiver is operating. Operation of the receiver outside the cabinet or with the back board removed involves a shock hazard from the receiver.
 - 1) Servicing should not be attempted by anyone who is not thoroughly familiar with the precautions necessary when working on high voltage equipment.
 - 2) Discharge the high potential of the picture tube before handling the tube. The picture tube is highly evacuated and if broken, glass fragments will be violently expelled.
2. If any Fuse in this TV receiver is blown, replace it with the FUSE specified in the Replacement Parts List.
3. When replacing a high wattage resistor (metal oxide film resistor) in the circuit board, keep the resistor 10 mm away from circuit board.
4. Keep wires away from high voltage or high temperature components.
5. This receiver must operate under AC 220 ~ 240 volts, 50 Hz. NEVER connect to DC supply or any other power or frequency.

PRODUCT SAFETY NOTICE

Many electrical and mechanical parts in this equipment have special safety-related characteristics. These characteristics are often passed unnoticed by a visual inspection and the X-RAY RADIATION protection afforded by them cannot necessarily be obtained by using replacement components rated for higher voltage, wattage, etc. Replacement parts which have these special safety characteristics are identified in this manual and its supplements, electrical components having such features are identified by designated symbol on the parts list. Before replacing any of these components, read the parts list in this manual carefully. The use of substitutes replacement parts which do not have the same safety characteristics as specified in the parts list may create X-RAY Radiation.

3 - Alignment instructions

3-1 Microcontroller configuration : Service mode

To switch the TV set into service mode please see instruction below.

- 1 - Select pr. number 91
- 2 - Adjust sharpness to minimum and exit all menu.
- 3 - Quickly press the key sequence : **RED - GREEN - menu**

To software version is displayed beside the word Service, e.g. “ SERVICE V1.00A ”.

To exit SERVICE menu press **menu** key or **Std By** key.

3-2 Service mode navigation

- Pr Up / Down remote keys : cycle through the service items available.
 Vol- / + remote keys : Decrement / Increment the values within range.
 0~7 digit keys : Toggle bits 0~7 in option byte

Order	Item	Default settingh for wp 895
1	PARABOLA	+140
2	HOR WIDTH	-1100
3	CORNER	-80
4	HOR.PARAL	-1
5	V.LINEAR	-2
6	EW TRAPEZ	-12
7	S CORRECT	-15
8	H BOW	+100
9	VERT SIZE	+145
10	VERT CENT	+3939
11	RED GAIN	+92
12	GRN GAIN	+87
13	BLUE GAIN	+95
14	RED BIAS	+128
15	GRN BIAS	+128
16	HOR CEN	98
17	AGC LEVEL	-
18	G2-SCREEN	-
19	AFT	-
20	OPTION	-
21	MAXV OL	Not used

3-3 Microcontroller configuration : Option bits

MICOM	Bits in OPTION		Bits in OPTION2		COMMENTS
	USED	NOT USED (set to '0')	USED	NOT USED (set to '0')	
VCT3834A C4 DWO2 VCT3832A C4 DW03	7, 6, 5, 2, 1, 0	4, 3	OPTION2 does not exist		Up to, but not including COB version 0.14 No tuner option 11 (ROM V1.00 A/B)
DW3834A-C4-AE2 DW3832A-C4-BE2	7, 6, 5, 4, 2, 1, 0	3	3, 2, 1, 0	7, 6, 5, 4	From V0.17 COB (ROM V2.00 A/B)

There are two option bytes available (16 bits in all). These option bits are available from Service mode. First find the OPTION or OPTION2 control, and then use keys 0..7 on the remote keypad to control bits 0 to 7 respectively. The table below shows the two option bytes available;

OPTION1							
	B7	B6	B5	B4	B3	B2	B1 B0
1	TOP text off	FASTEXT FLOF off	TUBE 4:3	AUTO 4:3 switch to PANORAMA	X	SVHS3 disable	Tuner options 00 = Philips 01 = ALPS 10 = Philips(AGC intern) 11 = Daewoo
0	TOP text on	FASTEXT (FLOF) on	TUBE 16:9	AUTO 4:3 switch to 4:3		SVHS3 enable	

OPTION2							
	B7	B6	B5	B4	B3	B2	B1 B0
1	Y	Y	Y	Y	Normal I brightness		See table below. OPTION2 bits B2 B1 B0
0					Normal I brightness +5 steps		

OPTION2 bits B2 B1 B0					
B2	B1	B0	Beam Current (mA)		Tube
			Nominal	Max	
1	1	1	0.95	1.10	28" 4:3 Normal (Philips, Thomson) 28" 16:9 Super Flat (Philips, Thomson)
1	1	0	1.00	1.15	
1	0	1	1.05	1.20	28" 4:3 Normal (Tesla)
1	0	0	1.10	1.25	
0	1	1	1.20	1.44	28" 16:9 Real Flat (Thomson) 29" 4:3 Real Flat (Thomson)
0	1	0	1.25	1.49	
0	0	1	1.30	1.53	
0	0	0	0.90	1.05	21" 4:3 Real Flat (Philips)

Set all the unused bits, marked 'X', to be 0 for future compatibility.
Set all the unused bits, marked 'Y', to be 1 for future compatibility.

Entering Factory mode Option bits

To switch the TV set into FACTORY mode, use the factory remote control, and press on "SVC". The factory menu will appear on the screen, showing "FACTORY Vx.xxX" (where x.xx is the software version) and X is the project. A is the correct project for WP895/895F, CP-485/885F, and B is for the CP885 chassis.

To find the option bits, push the button "OPT" once. Then "00000000 OPTION" will appear (assuming that all bits are already zero) to indicate all 8 option bits. To find OPTION2 press the button "OPT" a second time. From left to right, bits 7 to 0 are shown.

Toggling option bits

This is done from the user remote control, as there are no unallocated keys available from the factory remote control.

Each bit, from bit 7 to bit 0 is represented by its own key. Each key will, with repeated use, toggle on/off the associated bit. See the table below for the keys to use.

Bit	B7	B6	B5	B4	B3	B2	B1	B0
User remote control key	Text HOLD	Text SubPage Mode	Text Reveal	Text Double Height	Red	Green	Yellow	Blue

After setting option bits

Before pushing on the shipping key, "AGC", it is necessary to push the "NORMAL" key to obtain NORMAL I. This will reset all the sound and brightness settings to a factory defined level, as well as some other settings such as sound PRESET and WAKE TIME/PROG.

Then, on pushing the shipping key, these levels are memo rised in the television, ready for packing and delivery.

Verification

On pushing the shipping "AGC" key, a four digit hexadecimal number is displayed in addition to "SHIPPING". This number is there to verify the option bits setting that has been entered. For example the binary code 0000 0111 (OPTION2) 1100 0010 (OPTION) will give 07 C2 hex. The order of display is therefore OPTION2 then OPTION when reading from left to right.

3-4 TV set Alignment

3-4-1- Local oscillator alignment

Tune a colour bar pattern. The frequency of the signal carrier must be accurate (Max +/- 10Khz deviation from the nominal channel frequency).

Find "AFT" item in service mode.

Adjust the coil L150 to bring the cursor to central position : 32.

3-4-2- G2 alignment

- Tune a colour bar pattern.

- Find the "G2 - SCREEN" item in service mode.

- Adjust screen volume (on FBT) to bring the cursor to central position : 32.

3-4-3- White balance

- Select a dark picture and adjust RED BIAS and GRN BIAS to the desired colour temperature.

- Select a bright picture and adjust RED, GRN and BLUE GAIN to the desired colour temperature.

3-4-4- Focus

Adjust the Focus volume (on FBT) to have the best resolution on screen.

3-4-5- Vertical geometry

Adjust V.LINEAR (linearity), S CORRECT (S. Correction), VERT SIZE (Vertical amplitude), VERT CENT (vertical centring) to compensate for vertical distortion.

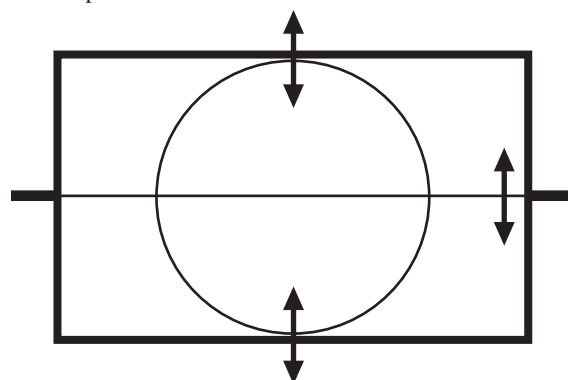

3-4-6- Horizontal picture centring

Adjust HOR CEN(Horizontal center) to have the picture in the center of the screen.

3-4-7- Eau/West comection

Adjust the PARABOLA, HOR WIDTH, CORNER, HOR PARAL, EW TRAPEZ H BOW, to compensate for geometrical distorrin,

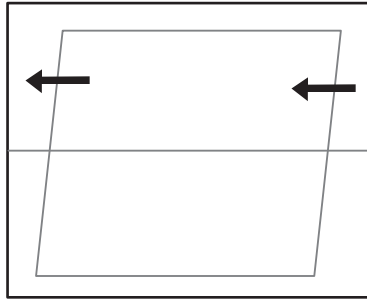

HOR PARAL

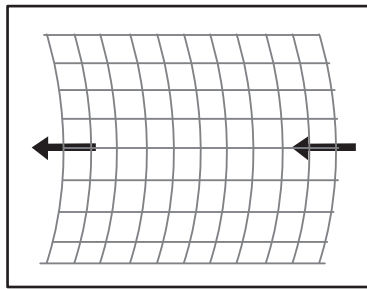

H BOW

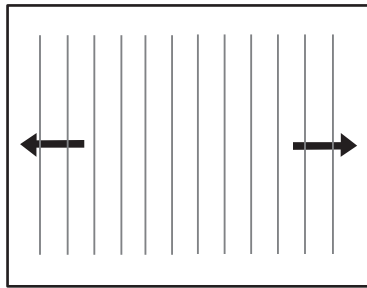

HOR WIDTH For HOR WIDTH, adjust for 91% overscan.

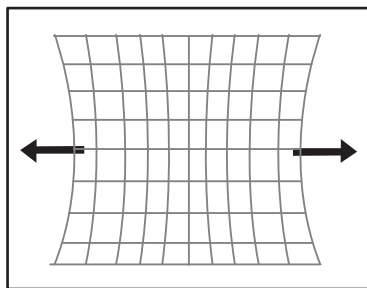

PARAROLA

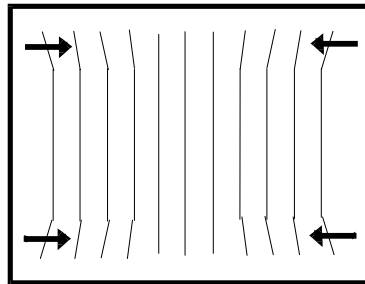

CORNER

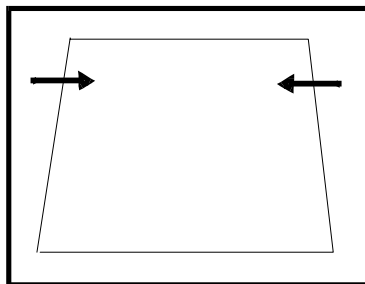

EW TRAPEZ

3-4-8- AGC

- Adjust the antenna signal level at $70 \text{ dB}\mu\text{V} \pm 2$
- Tune a colour bar pattern.
- Find the "AGC" item in service mode.
- Adjust AGC volume (RB10) to bring the cursor to central position : 32.

4 - IC description

4-1 VCT383XA TV signal processor - Teletext decoder with embedded 8 bit μ - Controller.

4-1-1- Block diagram of the VCT

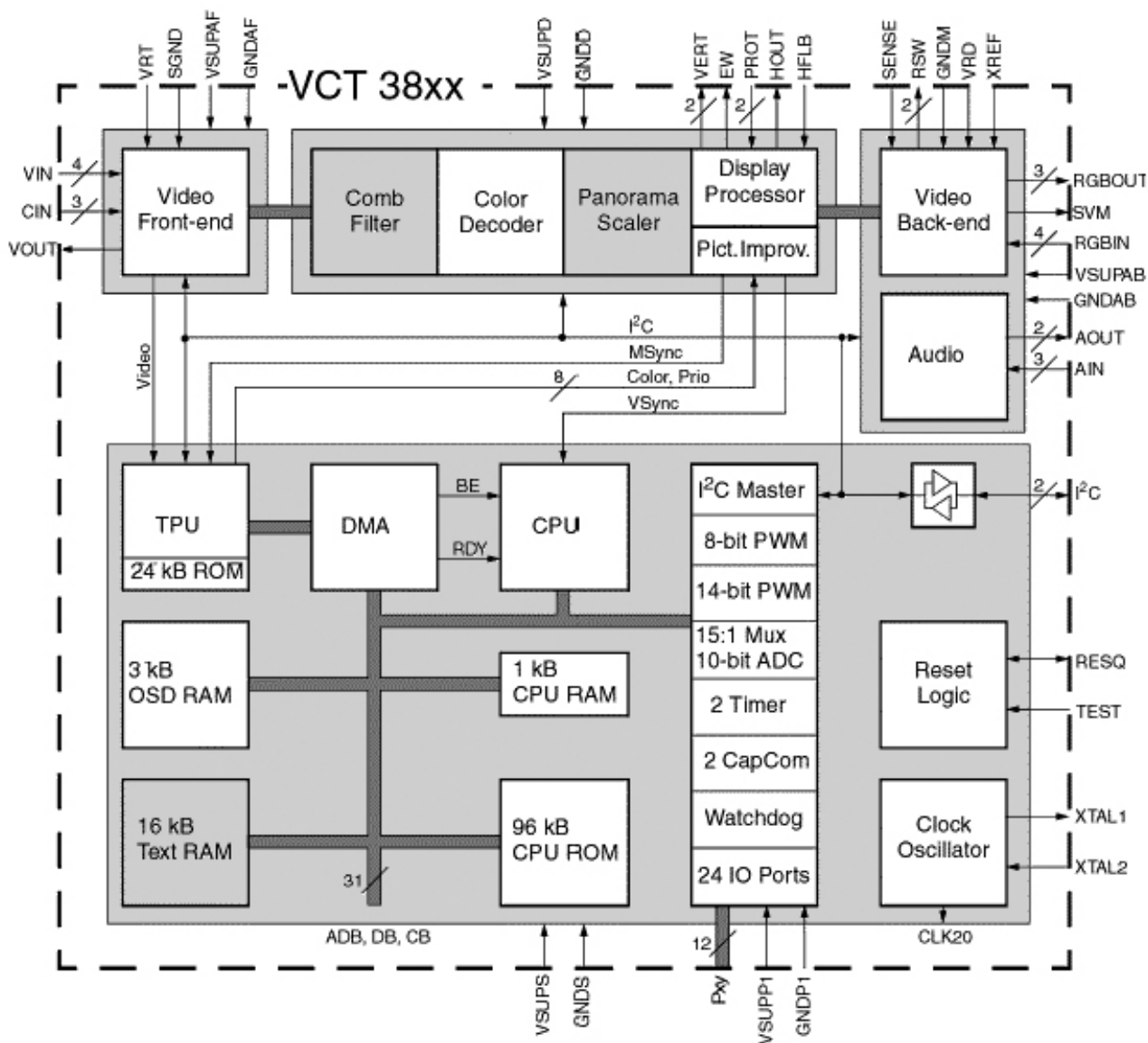

4-1-2- TV-signal Processor

- Four composite video inputs, two S-VHS inputs
- Analogue YCrCb input
- Composite video monitor
- Multistandard colour decoder (1 crystal)
- Multistandard sync decoder
- Black-line detector
- Adaptive 2H comb filter Y/C separator

- Horizontal scaling (0.25 to 4)
- Panoramavision
- Black-level expander
- Dynamic peaking
- Soft limiter (gamma correction)
- Colour transient improvement
- Programmable RGB matrix
- Analogue RGB/Fastblank input
- Half-contrast switch
- Picture frame generator
- Scan velocity modulation output
- High-performance H/V deflection
- Angle and bow correction
- Separate ADC for tube measurements
- EHT compensation

4-1-3- μ -Controller

- 8-bit, 10-Mhz CPU (65C02)
- 96 kB program ROM on chip
- 1 kB program RAM on chip
- memory banking
- 16-input, 16-level interrupt controller
- patch module for 10 ROM locations
- two 16-bit reloadable timers
- capture compare module
- watchdog timer
- 14-bit PWM for voltage synthesis
- Four 8-bit PWMs
- 10-bit ADC with 15:1 input MUX
- I2C bus master interface
- 24 programmable I/O ports
- 80C51 μ -controller core standard instruction set and timing
- 1 μ s machine cycle
- 32-128Kx8-bit late programmed ROM
- 3-12Kx8-bit Auxiliary RAM (shared with Display and Acquisition)
- Interrupt controller for individual enable/disable with two level priority
- Two 16-bit Timer/Counter registers
- WatchDog timer
- Auxiliary RAM page pointer
- 16-bit Data pointer
- IDLE and Power Down (PD) mode
- 14 bits PWM for Voltage Synthesis Tuning
- 8-bit A/D converter
- 4 pins which can be programmed as general I/O pin, ADC input or PWM (6-bit) output

4-1-4- Teletext Features

- Four programmable video inputs
- Adaptive data slicer
- Signal quality detection
- WST, PDC, VPS, and WSS acquisition

- High-level command language
- FLOF (Fastext), and TOP support
- 10 pages memory on chip (10kB)

4-1-5- Display OSD Features

- 3kB OSD RAM on chip
- WST level 1.5 compliant
- WST level 2 parallel attributes
- 32 foreground/background colours
- programmable colour look-up table
- 1024 mask programmable characters
- 17 national languages
- (Latin, Cyrillic and Greek character sets)
- Character matrix 10x10
- 4-color mode for user font

4-1-6- Audio Features

- Three mono inputs
- Two mono outputs
- Programmable channel select
- Volume control for one mono channel

4-1-7- General Features

- Submicron CMOS technology
- Low-power standby mode
- Single 20.25 MHz crystal
- 64-pin PSDIP package

4-1-8- Data Capture

The Video Front End section takes in the analogue Composite Video and Blanking Signal (CVBS), and from this extracts the required data, which is then decoded and stored in memory.

The extraction of the data is performed in the digital domain. The first stage is to select and convert the analogue CVBS signal into a digital form. This is done using 8 bit ADC sampling at 20.25 Mhz.

The digital data services transmitted in the VBI are selected and acquired separately from the video part. This is done by the use of an adaptive data slicer. The following data types can be extracted : 625 line World System Teletext (WST), VPS, WSS. The data is acquired and decoded by the teletext decoder (TPU), then stored in an SRAM Interface.

4-1-9- Data Capture Features

- Video Signal Quality detector
- Data Capture for 625 line WST
- Data Capture for VPS data (PDC system A)
- Data Capture for Wide Screen Signalling (WSS) bit decoding
- Real-time capture and decoding for WST Teletext in Hardware, to enable optimised microprocessor throughput
- 10 page memory stored On-Chip

- Inventory of transmitted Teletext pages stored in the Page Table
- Signal quality detector for WST data
- Comprehensive Teletext language coverage
- Full Field Vertical Blanking Interval (VBI) data capture of WST data

4-1-10- TV processor version and μ Controller capacity

IC version	VCT 3832A	VCT 3834A
8 bit μ -controller	✓	✓
ROM size	96k	96k
RAM size	1k	1k
PAL decoder	✓	✓
SECAM decoder	✓	✓
NTSC decoder	✓	✓
Picture improvement	✓	✓
Teletext page memory	10 pages	10 pages
Adaptive Comb filter	X	✓
Panorama Scaler		✓

4-1-11- IC marking and version

Chassis	IC marking	OSD languages	ATSS countries	Text
CP885	VCT3832A	English, French, German, Italian, Spanish, Dutch, Danish, Finnish, Norwegian, Swedish, Greek, Polish, Hungarian, Czech, Slovakian, Romanian, Russian.	GB, France, Germany, Italy, Belgium, Spain, Austria, Poland, Switzerland, Denmark, Finland, Netherlands, Norway, Sweden, Ireland, Hungary, Czech Republic, Others	Pan-European Latin. Cyrillic, Greek.
CP885F	VCT3834A			
WP895F/CP485F	VCT3834A			
WP895	VCT3834A			

4-1-12- Pinning

PSDIP 64-pin	Pin Name	Type	Short Description
1	Power	OUT	High = SMPS ON, Low = SMPS in stand by mode.
2	AGC	IN	For service only, tuner AGC, TOP alignment.
3	VSUPP1	SUPPLY	Supply Voltage, Port (pin 1, 2, 5, 6, 7, 8, 9, 10, 61, 62, 63, 64).
4	GNDP1	SUPPLY	Ground, Port.
5	MOD_SW	OUT	High = Negative modulation, Low = Positive modulation (L/L').
6	SECAM L/L'	OUT	High = L', Low = L.
7	AFC	IN	
8	IR	IN	
9	SC1.SW	IN	
10	SC2.SW	IN	
11	VOUT	OUT	Analog Video Output
12	VRT	IN	Reference Voltage Top, Video ADC
13	SGND	IN	Signal Ground for Analog Input

PSDIP 64-pin	Pin Name	Type	Short Description
14	GNDAF	SUPPLY	Ground, Analog Front-end
15	VSUPAF	SUPPLY	Supply Voltage, Analog Front-end
16	CBIN	IN	Analog Component Cb Input
17	CIN1	IN	Analog Chroma 1 Input
18	CIN2/CRIN	IN	Analog Chroma 2 Input / Analog Component Cr Input
19	VIN1	IN	Analog Video 1 Input
20	VIN2	IN	Analog Video 2 Input
21	VIN3	IN	Analog Video 3 Input
22	VIN4	IN	Analog Video 4 Input
23	TEST	IN	Test Pin, Reserved For Test
24	HOUT	OUT	Horizontal Drive Output
25	VSUPD	SUPPLY	Supply Voltage, Digital Circuitry
26	GNDD	SUPPLY	Ground, Digital Circuitry
27	FBLIN	IN	Fast Blank Input
28	RIN	IN	Analog Red Input
29	GIN	IN	Analog Green Input
30	BIN	IN	Analog Blue Input
31	VPROT	IN	Vertical Protection Input
32	SAFETY	IN	Safety Input
33	HFLB	IN	Horizontal Flyback Input
34	VERTQ/ INTLC	OUT	Differential Vertical Sawtooth Output Interlace Control Output
35	VERT	OUT	Differential Vertical Sawtooth Output
36	EW	OUT	Vertical Parabola Output
37	SENSE	IN	Sense ADC Input
38	GNDM	SUPPLY	Ground, MADC Input
39	RSW1	OUT	Range Switch1 for Measurement ADC
40	RSW2	OUT	Range Switch2 for Measurement ADC
41	SVMOUT	OUT	Scan Velocity Modulation Output
42	ROUT	OUT	Analog Red Output
43	GOUT	OUT	Analog Green Output
44	BOUT	OUT	Analog Blue Output
45	VSUPAB	SUPPLY	Supply Voltage, Analog Back-end
46	GNDAB	SUPPLY	Ground, Analog Back-end
47	VRD	IN	DAC Reference
48	XREF	IN	Reference Input for RGB DACs
49	AIN3	IN	Analog Audio 3 Input
50	AIN2	IN	Analog Audio 2 Input
51	AIN1	IN	Analog Audio 1 Input
52	AOUT2	OUT	Analog Audio 2 Output
53	AOUT1	OUT	Analog Audio 1 Output
54	VSUPS	SUPPLY	Supply Voltage, Standby
55	GNDS	SUPPLY	Ground, Standby
56	XTAL1	IN	Analog Crystal Input
57	XTAL2	OUT	Analog Crystal Output
58	RESQ	IN/OUT	Reset Input/Output, Active Low
59	SCL	IN/OUT	I 2 C Bus Clock
60	SDA	IN/OUT	I 2 C Bus Data
61	Mute	OUT	High = Mute active
62	LED	OUT	High = Green, Low = Red
63	KB	IN	Local keyboard ADC input
64	OC	IN	Over Current Protection input

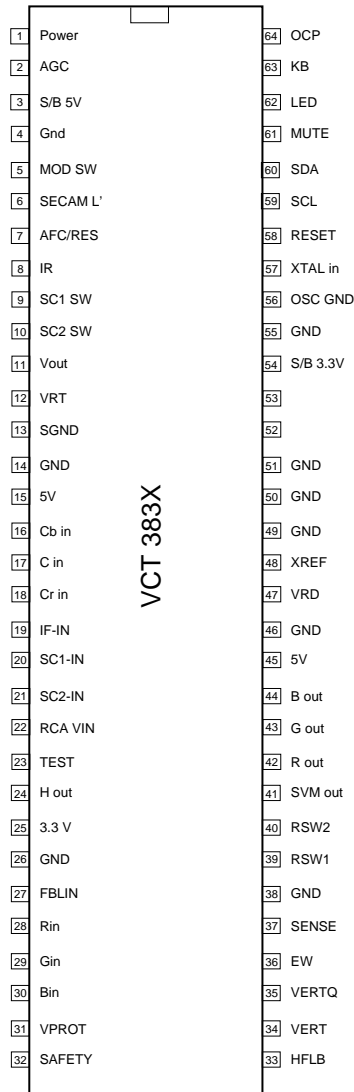

4-2 MSP341x Multistandard Sound Processor

The MSP 341x is designed as a single-chip Multistandard Sound Processor for applications in analogue and digital TV sets, video recorders, and PC cards.

The MSP3411 has all functions of MSP3410 with the addition of a virtual surround sound feature.

A Surround sound affect can be reproduced with two loudspeakers. The MSP3411 includes virtualizer algorithm "3D Panorama" which has been approved by the Dolby laboratories for compliance with the "Virtual Dolby Surround" technology. In addition, the MSP3411 includes Micronas "Panorama" algorithm.

MSP 341x features :

- sound IF input
- No external filters required
- Stereo baseband input via integrated AD converters
- Two pairs of DA converters
- Two carrier FM or NICAM processing
- AVC : Automatic Volume Correction
- Bass, treble, volume processing
- Full SCART in/out matrix without restrictions
- Improved FM-identification
- Demodulator short programming
- Autodetection for terrestrial TV - sound standards
- Precise bit-error rate indication
- Automatic switching from NICAM to FM/AM or vice versa
- Improved NICAM synchronisation algorithm
- Improved carrier mute algorithm
- Improved AM-demodulation
- Reduction of necessary controlling
- Less external components

4-2-1- Basic Features of the MSP 341x

4-2-1-1 Demodulator and NICAM Decoder Section

The MSP 341x is designed to simultaneously perform digital demodulation and decoding of NICAM-coded TV stereo sound, as well as demodulation of FM or AM mono TV sound. Alternatively, two carrier FM systems according to the German terrestrial specs can be processed with the MSP 341x.

The MSP 341x facilitates profitable multistandard capability, offering the following advantages:

- Automatic Gain Control (AGC) for analogue input: input range: 0.10 - 3 Vpp
- integrated A/D converter for sound-IF input
- all demodulation and filtering is performed on chip and is individually programmable
- easy realisation of all digital NICAM standards (B/G, I, L and D/K)
- FM-demodulation of all terrestrial standards (include identification decoding)
- no external filter hardware is required
- only one crystal clock (18.432 MHz) is necessary

- high deviation FM-mono mode (max. deviation: approx. ± 360 kHz)

4-2-1-2 DSP-Section (Audio Baseband Processing)

- flexible selection of audio sources to be processed
- performance of terrestrial de-emphasise systems (FM, NICAM)
- digitally performed FM-identification decoding and de-matrixing
- digital baseband processing: volume, bass, treble
- simple controlling of volume, bass, treble

4-2-1-3 Analogue Section

- two selectable analogue pairs of audio baseband input (= two SCART inputs) input level: < 2 V RMS, input impedance: > 25 k Ω
- one selectable analogue mono input (i.e. AM sound): Not used in this chassis
- two high-quality A/D converters, S/N-Ratio: > 85 dB
- 20 Hz to 20 kHz bandwidth for SCART-to-SCART copy facilities
- loudspeaker: one pair of four-fold oversampled D/A converters. Output level per channel: max. 1.4 VRMS output resistance: max. 5 k Ω , S/N-ratio: > 85 dB at maximum volume Max. noise voltage in mute mode: < 10 μ V (BW: 20 Hz... 16kHz)
- one pair of four-fold oversampled D/A converters supplying a pair of SCART-outputs. output level per channel: max. 2 V RMS, output resistance: max. 0.5 k Ω , S/N-Ratio: > 85 dB (20 Hz... 16 kHz)

4-2-1-4 NICAM plus FM/AM-Mono

According to the British, Scandinavian, Spanish, and French TV-standards, high-quality stereo sound is transmitted digitally. The systems allow two high-quality digital sound channels to be added to the already existing FM/AM-channel. The sound coding follows the format of the so-called Near Instantaneous Companding System (NICAM 728). Transmission is performed using Differential Quadrature Phase Shift Keying (DQPSK. Table below offers an overview of the modulation parameters.)

In the case of NICAM/FM (AM) mode, there are three different audio channels available: NICAM A, NICAM B, and FM/AM-mono. NICAM A and B may belong either to a stereo or to a dual language transmission. Information about operation mode and about the quality of the NICAM signal can be read by the controlling software via the control bus. In the case of low quality (high bit error rate), the controlling software may decide to switch to the analogue FM/AM-mono sound. Alternatively, an automatic NICAM-FM/AM switching may be applied.

4-2-1-5 German 2-Carrier System (DUAL FM System)

Since September 1981, stereo and dual sound programs have been transmitted in Germany using the 2-carrier system. Sound transmission consists of the already existing first sound carrier and a second sound carrier additionally containing an identification signal. More details of this standard are given in Tables below. For D/K very similar system is used.

TV standards

TV system	Position of sound carrier (MHz)	Sound modulation	Color system	Country
B/G	5.5 / 5.7421875	FM Stereo	PAL	Germany
B/G	5.5 / 5.85	FM-Mono / NICAM	PAL	Scandinavia, Spain
L	6.5 / 5.85	AM-Mono / NICAM	SECAM-L	France
I	6.0 / 6.552	FM-Mono / NICAM	PAL	UK
D/K	6.5 / 6.2578125 D/K1 6.5 / 6.7421875 D/K2 6.5 / 5.85 D/K-NICAM	FM Stereo FM-Mono / NICAM	SECAM-East	USSR Hungary

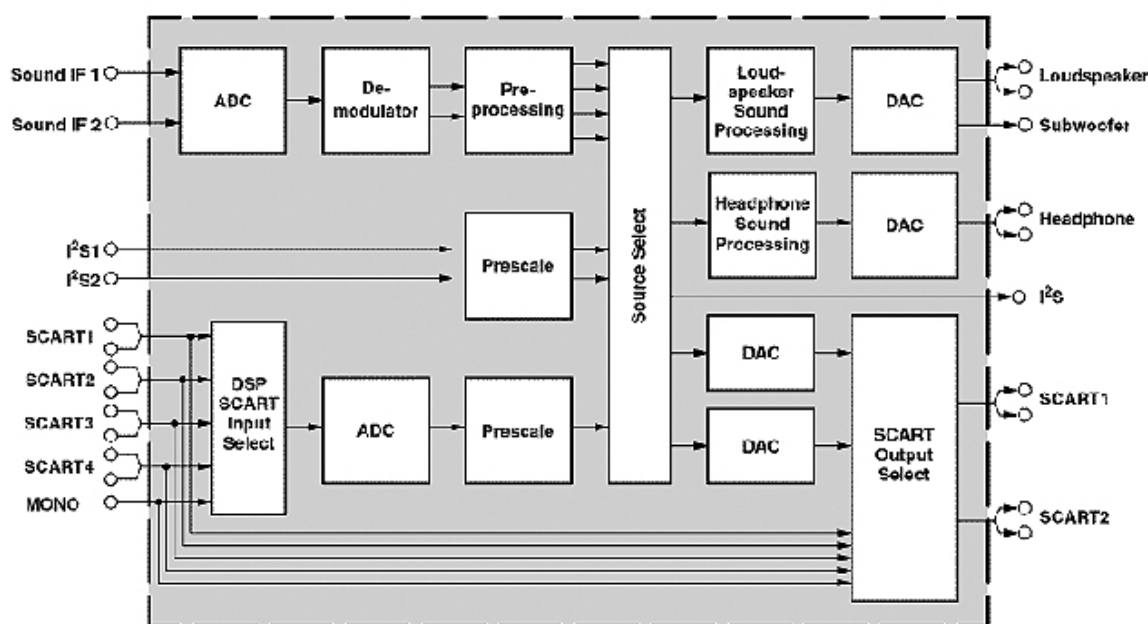

Architecture of MSP341x

Pin connections and short description

Pin No.	Pin Name	Type	Short description
1	TP	Out	Test pin
2	NC		Not Connected
3	NC		Not Connected
4	TP	Out	Test pin
5	TP	Out	Test pin
6	ADR_SEL	In	I2C bus Address select
7	STANDBYQ	In	Standby (Low-active)
8	NC		Not Connected
9	I2C_CL	In / Out	I2C Clock
10	I2C_DA	In / Out	I2C data
11	TP	In / Out	Test pin

Pin No.	Pin Name	Type	Short description
12	TP	In / Out	Test pin
13	TP	Out	Test pin
14	NC		Not Connected
15	TP	Out	Test pin
16	TP	Out	Test pin
17	TP	Out	Test pin
18	DVSUP		Digital power supply +5V
19	DVSS		Digital Ground
20	NC		Not Connected
21	NC		Not Connected
22	NC		Not Connected
23	NC		Not Connected
24	RESETQ	In	Power-On-reset
25	NC		Not Connected
26	NC		Not Connected
27	VREF2		Reference ground 2 high voltage part
28	DACM_R	Out	Loudspeaker out Right
29	DACM_L	Out	Loudspeaker out Left
30	NC		Not Connected
31	TP	Out	Test pin
32	NC		Not Connected
33	NC		Not Connected
34	NC		Not Connected
35	VREF1		Reference ground 1 high voltage part
36	SC1_OUT_R	Out	Scart output 1, right
37	SC1_OUT_L	Out	Scart output 1, left
38	NC		Not Connected
39	AHVSUP		Analog power supply 8.0V
40	CAPL_M		Volume capacitor MAIN
41	AHVSS		Analog ground
42	AGNDC		Analog reference voltage high voltage part
43	NC		Not Connected
44	NC		Not Connected
45	NC		Not Connected
46	NC		Not Connected
47	NC		Not Connected
48	ASG2		Analog Shield Ground 2
49	SC2_IN_L	In	Scart input 2 in, left
50	SC2_IN_R	In	Scart input 2 in, right
51	ASG1		Analog Shield Ground 1
52	SC1_IN_L	In	Scart input 1 in, left
53	SC1_IN_R	In	Scart input 1 in, right
54	VREFTOP		Reference voltage IF A/D converter
55	MONO_IN	In	Mono input
56	AVSS		Analog ground
57	AVSUP		Analog power supply
58	ANA_IN1+		In IF input 1

Pin No.	Pin Name	Type	Short description
59	ANA_IN1-	In	IF common
60	NC		Not Connected
61	TESTEN	In	Test pin
62	XTAL_IN	In	Crystal oscillator
63	XTAL_OUT	Out	Crystal oscillator
64	NC		Test pin

4-3 TDA 4470-Multistandard Video-IF and Quasi Parallel Sound Processor

4-3-1- Description

The TDA 4470 is an integrated bipolar circuit for multi-standard video/sound IF (VIF/SIF) signal processing in TV/VCR and multimedia applications. The circuit processes all TV video IF signals with negative modulation (e.g., B/G standard), positive modulation (e.g., L standard) and the AM, FM/NICAM sound IF signals.

4-3-2- Features

- 5V supply voltage ; low power consumption.
- Active carrier generation by FPLL principle (frequency-phase-locked-loop) for true synchronous demodulation.
- Very linear video demodulation, good pulse response and excellent intermodulation figures.
- Alignment-free AFC without external reference circuit, polarity of the AFC curve is switchable.
- VIF-AGC for negative modulated signals (peak sync. detection) and for positive modulation (peak white/black level detector).
- Tuner AGC with adjustable take over point.
- Alignment-free quasi parallel sound (QPS) mixer for FM/NICAM sound IF signals.
- Inter-carrier output signal is gain controlled (necessary for digital sound processing).
- Complete alignment-free AM demodulator with gain controlled AF output.
- Separate SIF-AGC with average detection
- Two independent SIF inputs
- Parallel operation of the AM demodulator and QPS mixer (for NICAM-L stereo sound).

4-3-3- Pinning

Pin	Symbol	Function
1,2	$V_{i,SIF1}$	SIF1 input (symmetrical)
3	V_{SW}	Input selector switch
4,9,16	GND	Ground
5	V_{AGC}	SIF-AGC (time constant)
6,7	$V_{i,VIF}$	VIF input (symmetrical)
8	C_{AGC}	VIF-AGC (time constant)
10	R_{TOP}	Take Over Point, tuner AGC
11	I_{tun}	Tuner AGC output current
12	$V_{O,VID}$	Video output
13	V_{SW}	Standard switch
14	V_{SW}	L'switch
15	C_{bl}	Black level capacitor
17	C_{ref}	Internal reference voltage
18	LF	Loop Filter

Pin	Symbol	Function
19	V_{SW}	AFC switch
20, 21	V_{VCO}	VCO circuit
22	V_{AFC}	AFC output
23	V_S	Supply voltage
24	$V_{O,FM}$	Intercarrier output
25	$V_{O,AM}$	AF output-AM sound
26	R_{COMP}	Offset compensation
27, 28	$V_{i,SIF2}$	SIF2 input (symmetrical)

4-3-4 Block diagram

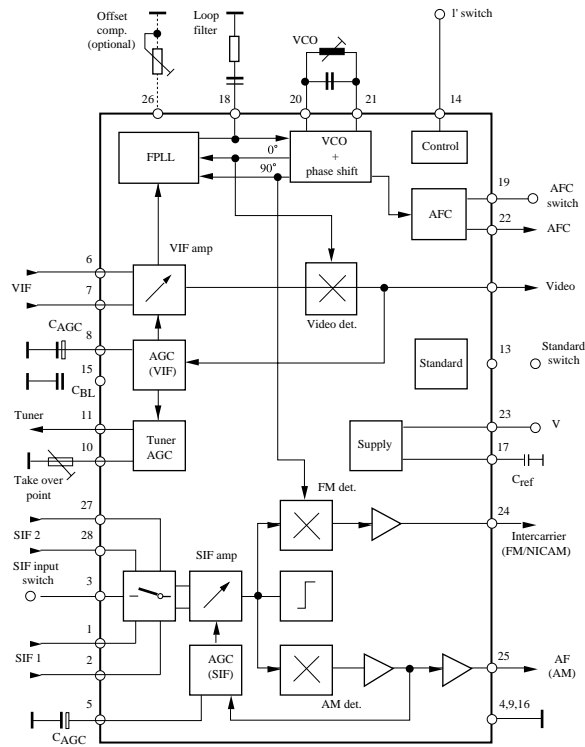

4-4 TDA894xJ Stereo Audio Amplifier

The TDA8944J(TDA 8946J) is a dual-channel audio power amplifier with an output power of 2 x 7W (2 X 15W) at an 8Ω load and a 12V supply. The circuit contains two Bridges Tied Load(BTL) amplifiers with an all-NPN output stage and standby/mute logic. The TDA8944J comes in a 17-pin DIL power package.

4-4-1- Features

- Few external components
- Fixed gain
- Standby and mute mode
- No on/off switching pop noise
- low standby current
- High supply voltage ripple rejection
- Outputs short-circuit protected to ground, supply and across the load
- Thermally protected

Pin description

Pin	Symbol	Description
1	OUT1-	negative loudspeaker terminal 1
2	GND1	ground channel 1
3	Vcc1	supply voltage channel 1
4	OUT1+	positive loudspeaker terminal 1
5	n.c.	not connected
6	IN1+	positive input1
7	n.c.	not connected
8	IN1-	negative input1
9	IN2-	negative input2
10	MODE	mode selection input
11	SVR	half supply voltage decoupling (ripple rejection)
12	IN2+	positive input2

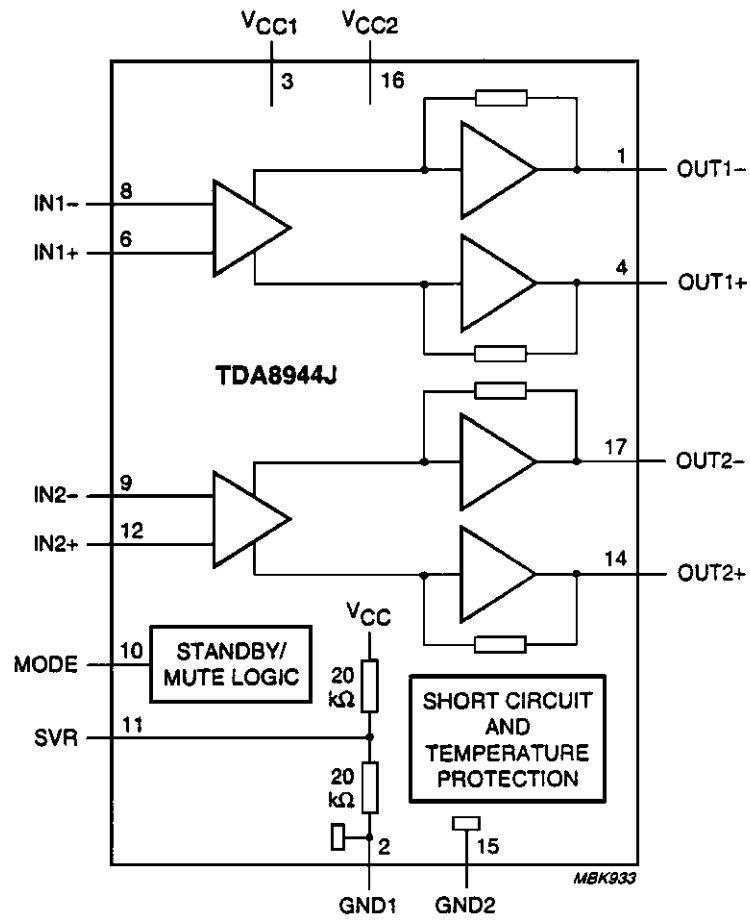

Block diagram TDA8944J

4-5 TDA835xJ Vertical Amplifier

The TDA835xJ are power circuit for use in 90° and 110° colour deflection systems for field frequencies of 25 to 200Hz and 16/9 picture tubes. The circuit provides a DC driven vertical deflection output circuit, operating as a highly efficient class G system. Due to the full bridge output circuit the deflection coils can be DC coupled.

The IC is constructed in a Low Voltage DMOS process that combines Bipolar, CMOS and DMOS devices. MOS transistors are used in the output stage because of the absence of second breakdown.

4-5-1 TDA8357J

Features :

- Few external components
- High efficient fully DC-coupled vertical output bridge circuit
- Short rise and fall time of the vertical flyback switch
- Guard circuit
- Temperature (thermal) protection
- High EMC because of common mode inputs

Pinning

Pin	Symbol	Description
1	$V_{i(pos)}$	input voltage (positive)
2	$V_{i(neg)}$	input voltage (negative)
3	V_p	supply voltage
4	V_{OB}	output voltage B
5	GND	ground
6	V_{flb}	flyback supply voltage
7	V_{OA}	output voltage A
8	$V_{O(guard)}$	guard output voltage
9	V_M	input measuring resistor

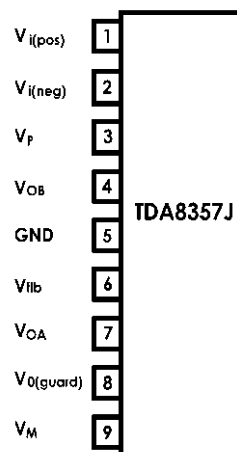

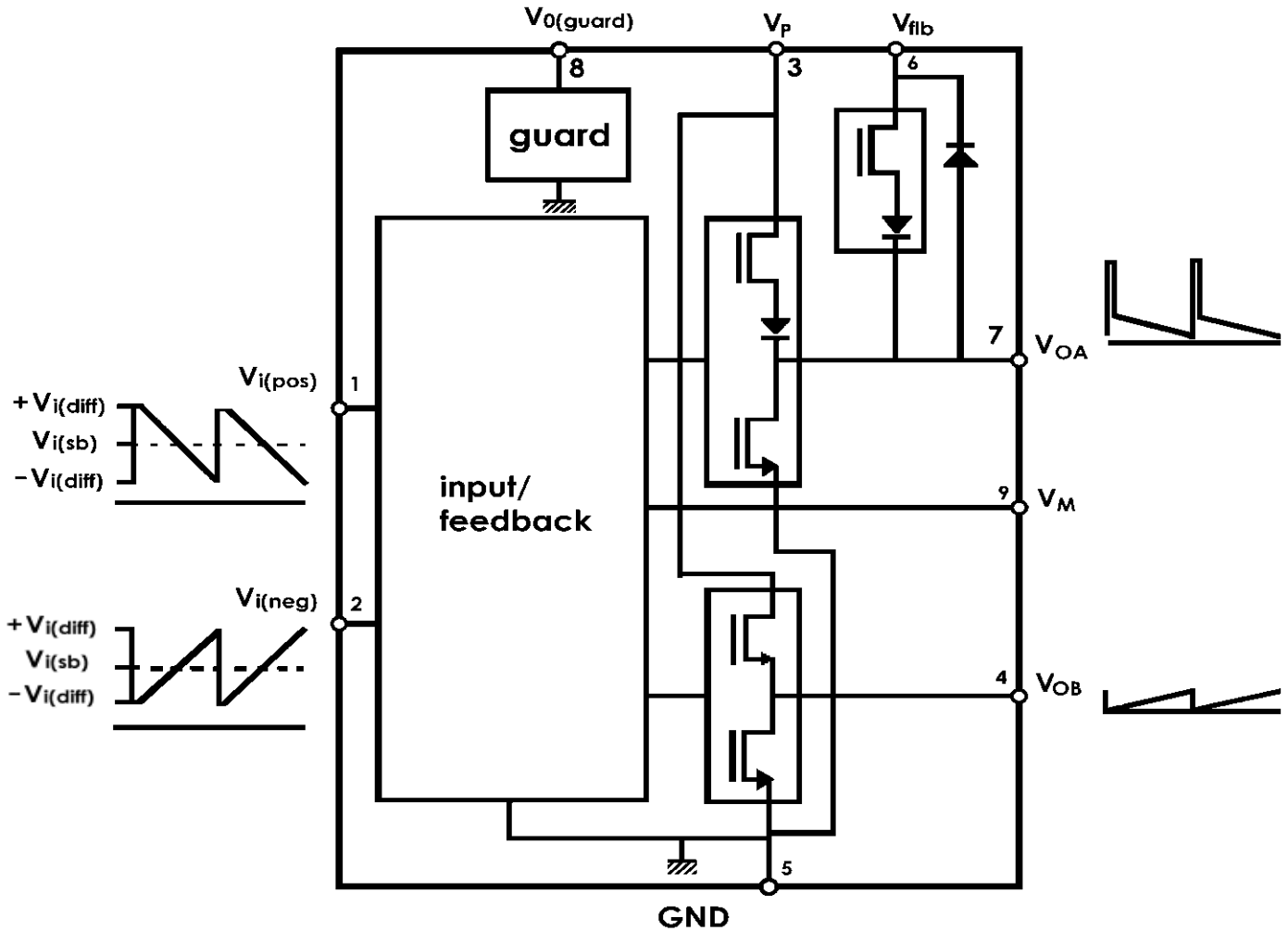

4-5-2 TDA8358J

An East-West output stage is provided that is able to sink current from the diode modulator circuit.

Features :

- Few external components
- Highly efficient fully DC-coupled vertical output bridge circuit
- Short rise and fall time of the vertical flyback switch
- Guard circuit
- Temperature (thermal) protection
- High EMC because of common mode inputs
- East-West output stage

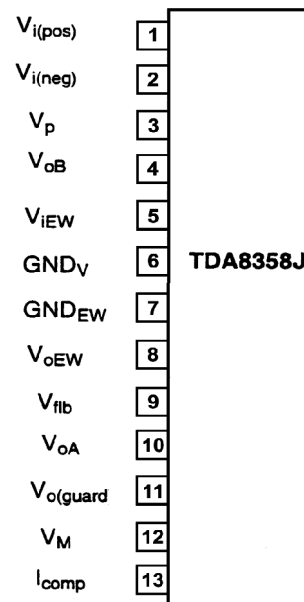

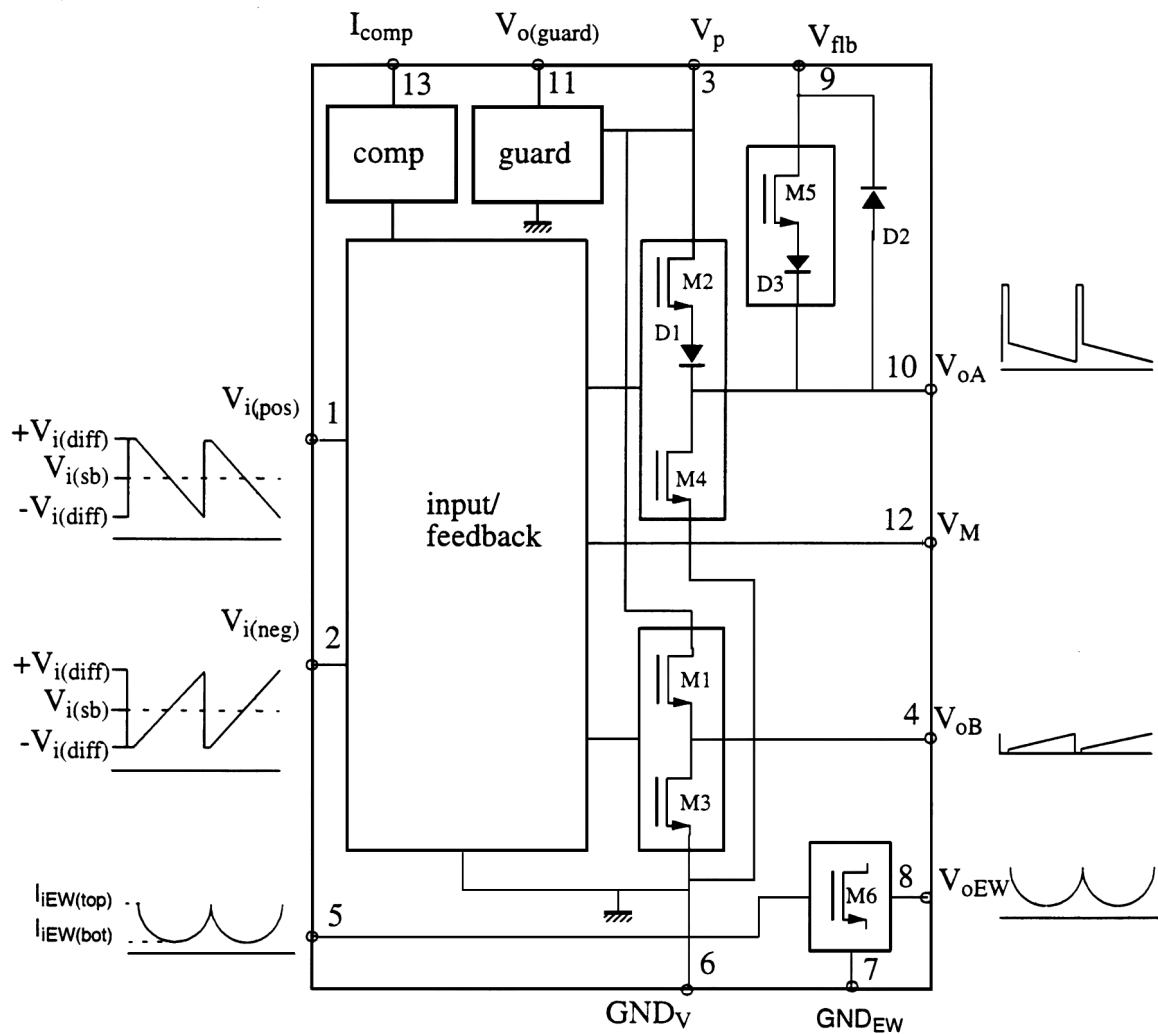

4-6 TDA6107Q

The TDA6107Q includes three video output amplifiers in one plastic DIL-Bent-SIL 9-pin medium power package, using high voltage DMOS technology, and is intended to drive the three cathodes of a colour CRT directly. To obtain maximum performance, the amplifier should be used with black-current control.

Features

- Typical bandwidth of 5.5 MHz for an output signal of 60 Vpp
- High slew rate of 900V/ μ s
- No external components required
- Very simple application
- Single supply voltage of 200V
- Internal reference voltage of 2.5 V
- Fixed gain of 50.
- Black-current stabilisation (BCS) circuit
- Thermal protection

Pin description

Pin	Symbol	Description
1	$V_{i(1)}$	inverting input 1
2	$V_{i(2)}$	inverting input 2
3	$V_{i(3)}$	inverting input 3
4	GND	ground (fin)
5	I_{om}	black current measurement output
6	V_{DD}	supply voltage
7	$V_{oc(3)}$	cathode output 3
8	$V_{oc(2)}$	cathode output 2
9	$V_{oc(1)}$	cathode output 1

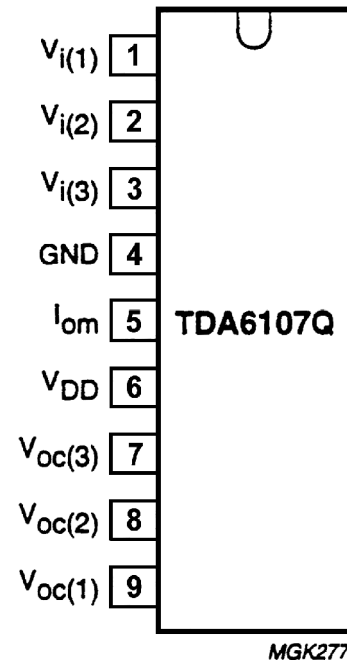

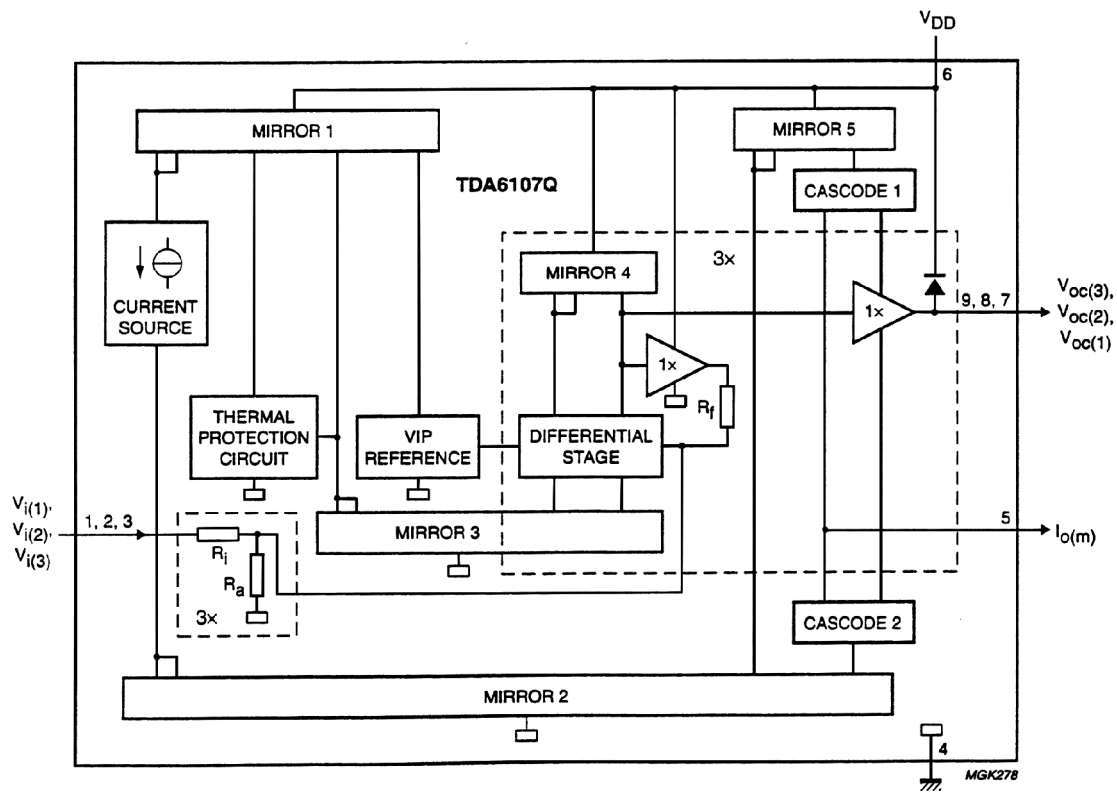

Block diagram TDA6107Q

4-6 24C16 - 16 Kb EEPROM

features :

- 16 Kbit serial I2C bus EEPROM
- Single supply voltage : 4.5 V to 5.5 V
- 1 Million Erase/Write cycles (minimum)
- 40 year data retention (minimum)

Pin description

Pin No.	Name	Description
1, 2, 3	E0, E1, E2	Device address - not used
5	SDA	Serral Data/Address Input/Output
6	SCL	Serial clock
7	WC	Write control
8	Vcc	Supply voltage
4	Vss	Ground

The memory device is compatible with the I2C memory standard. This is a two wire serial interface that uses a bi-directional data bus and serial clock. The memory carries a built-in 4-bit unique device type identifier code (1010) in accordance with the I2C bus definition.

Serial Clock (SCL)

The SCL input is used to strobe all data in and out of the memory.

Serial Data (SDA)

The SDA pin is bi-directional, and is used to transfer data in or out of the memory

4-8 STR - F6654

4-8-1 General description

The STR-F6654 is an hybrid IC with a build-in MOSFET and control IC, designed for flyback converter type switch mode power supply applications.

4-8-2 Features

- Small SIP fully isolated molded 5 pins package
- Many protection functions :
 - * Pulse-by-pulse overcurrent protection (OCP)
 - * Overvoltage protection with latch mode (OVP)
 - * Thermal protection with latch mode (TSD)

4-8-3 Block diagram

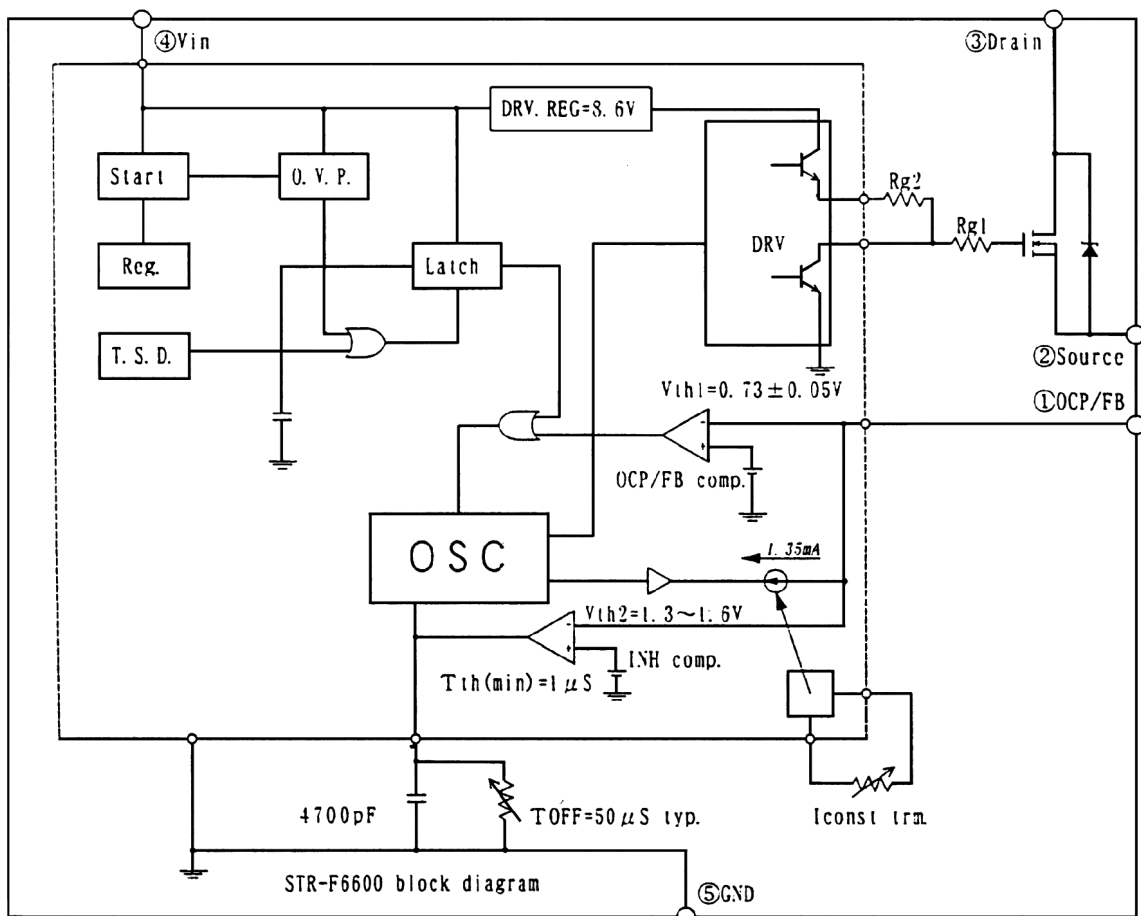

4-8-4 Pins description

pin	name	symbol	description
1	Overcurrent / feedback	O.C.P./ F.B.	Input of over current detection signal and feedback signal
2	Source	S	MOSFET source
3	Drain	D	MOSFET drain
4	Supply	V _{IN}	Input of power supply for control circuit
5	Ground	GND	Ground

4-8-5 Control part electrical characteristics

DESCRIPTION	IC PIN NUMBER	SYMBOL	RATING			UNIT
			MIN.	TYPE	MAX	
Operation start voltage	4-5	V _{IN} (on)	14.4	16	17.6	V
Operation stop voltage	4-5	V _{IN} (off)	9	10	11	V
Circuit current in operation	4-5	I _{IN} (on)	-	-	30	mA
Circuit current in non-operation	4-5	I _{IN} (off)	-	-	100	μA
Maximum OFF time	-	T _{OFF} (max)	45	-	55	μSEC
Minimum time for input of quaxi resonant signals	1-5	T _{TH} (2)	-	-	1.0	μSEC
Minimum off time	-	T _{OFF} (min)	-	-	1.5	μSEC
O.C.P./F.B. terminal threshold voltage 1	1-5	V _{TH} (1)	0.68	0.73	0.78	V
O.C.P./F.B. terminal threshold voltage 2	1-5	V _{TH} (2)	1.3	1.45	1.6	V
O.C.P./F.B. terminal extraction current	1-2	I _{OCP/FB}	1.2	1.35	1.5	mA
O.V.P. operation voltage	4-5	V _{IN} (OVP)	20.5	22.5	24.5	V
Latch circuit sustaining voltage	4-5	I _{IN} (H)	-	-	400	μA
Latch circuit release voltage	4-5	V _{IN} (La.off)	6.6	-	8.4	V
Thermal shutdown operating temperature	-	T _J (TSD)	140	-	-	°C

4-8-6 MOSFET electrical characteristics

DESCRIPTION	IC PINS NUMBER	SYMBOL	RATING			UNIT
			MIN.	TYPE	MAX	
Drain-to-source break voltage	3-2	V_{DSS}	650	-	-	V
Drain leakage current	3-2	I_{DSS}	-	-	300	μA
On-resistance	3-2	$R_{DS(on)}$	-	-	1.15	Ω
Switching time	3-2	t_f	-	-	250	sec
Thermal resistance	-	$\theta_{FH} -F$	-	-	0.95	$^{\circ}C/W$

5 - Circuit description

5-1 Block diagram

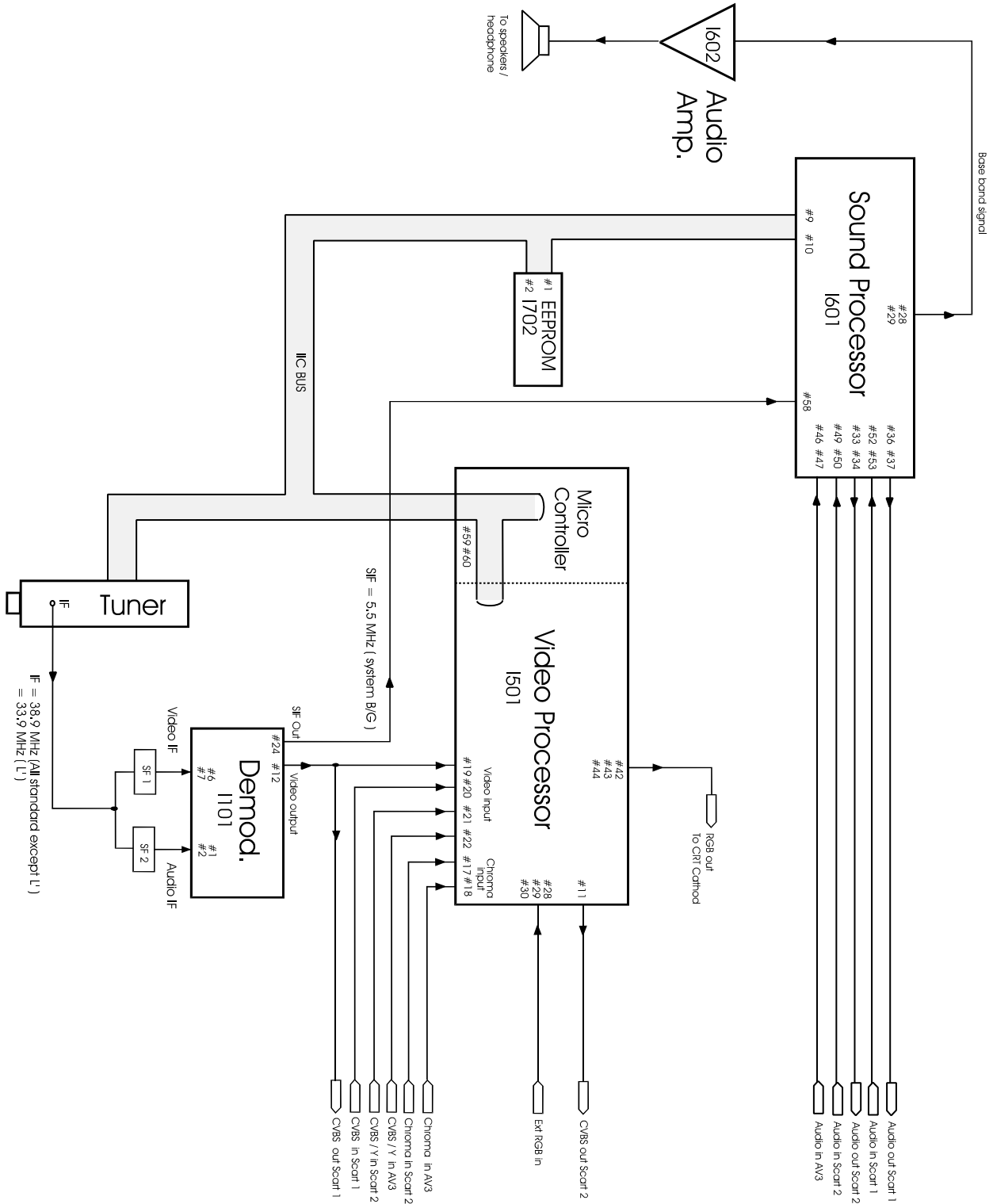

5-2 IF section

5-2-1 Block diagram

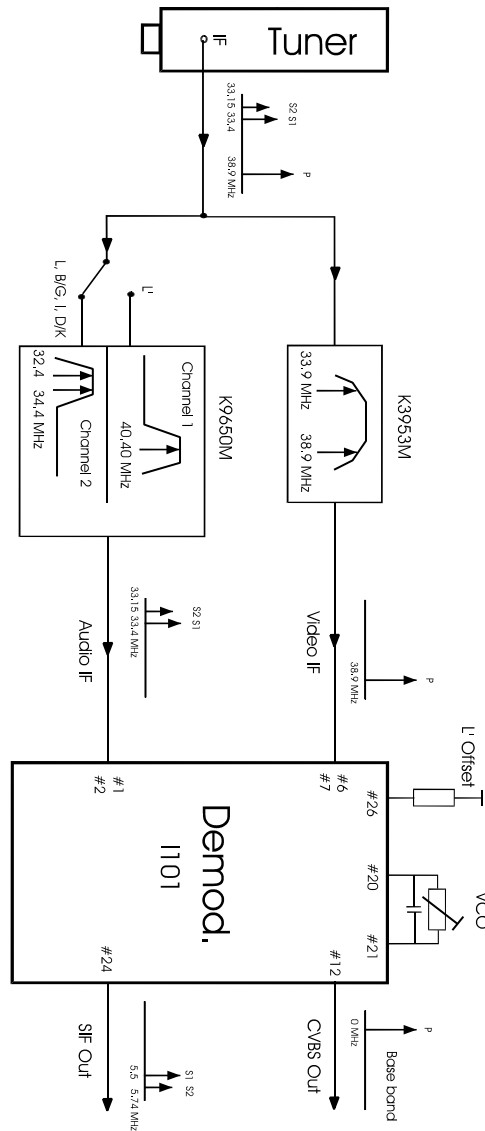

5-2-2 Vision IF Amplifier

The video IF signal (VIF) is fed through a SAW filter to the differential input (Pin 6-7) of the VIF amplifier. This amplifier consists of three AC-coupled amplifier stages. Each differential amplifier is gain controlled by the automatic gain control circuit (VIF-AGC). The output signal of the VIF amplifier is applied to the FPLL carrier generation and the video demodulator.

SAW filters

Ref.	Standard	Features
K3953M	B/G - D/K - I - L/L'	<ul style="list-style-type: none"> - IF filter for video application - TV IF filter with Nyquist slopes at 33.9 MHz and 38.9 MHz - Constant group delay
K9650M	B/G - D/K - I - L/L'	<ul style="list-style-type: none"> - IF filter for audio application - TV IF audio filter with two channels - Channel 1 (L') with one pass band for sound carrier at 40.40 MHz - Channel 2 (L, D/K, I, B/G) with one pass band for sound carriers between 32.40 MHz and 33.40 MHz

5-2-3 Tuner-and VIF-AGC

At Pin 8, the VIF-AGC charges/discharges the AGC capacitor to generate a control Voltage for setting the gain of the VIF amplifier and tuner in order to keep the video output signal at a constant level. Therefore, in the case of all negative modulated signals (e.g., B/G standard) the sync. level of the demodulated video signal is the criterion for a fast charge/discharge of the AGC capacitor. For positive modulation (e.g., L standard) the peak white level of video signal controls the charge current. In order to reduce reaction time for positive modulation, where a large time constant is needed, an additional black level detector controls the discharge current in the event of decreasing VIF input signal. The control voltage (AGC voltage at Pin 8) is transferred to an internal control signal, and is fed to the tuner AGC to generate the tuner AGC current at Pin 11 (open collector output). The take over point of the tuner AGC can be adjusted at Pin 10 by a potentiometer or an external dc voltage (from interface circuit or microprocessor).

5-2-4 FPLL, VCO and AFC

The FPLL circuit (frequency phase locked loop) consists of a frequency and phase detector to generate the control voltage for the VCO tuning. In locked mode, the VCO is controlled by the phase detector and in unlocked mode, the frequency detector is superimposed. The VCO operates with an external resonance circuit (L and C parallel) and is controlled by internal varicaps. The VCO control voltage is also converted to a current and represents the AFC output signal at Pin 22. At the AFC switch (Pin 19) three operating conditions of the AFC are possible: AFC curve "rising" or "falling" and AFC "off". A practicable VCO alignment of the external coil is the adjustment to zero AFC output current at Pin 22. At center frequency the AFC output current is equal to zero. Furthermore, at Pin 14, the VCO center frequency can be switched for setting to the required L' value (L' standard). The optional potentiometer at Pin 26 allows an offset compensation of the VCO phase for improved sound quality (fine adjustment). Without a potentiometer (open circuit at Pin 26), this offset compensation is not active. The oscillator signal passes a phase shifter and supplies the in-phase signal (0°) and the quadrature signal (90°) of the generated picture carrier.

5-2-5 Video Demodulation and Amplifier

The video IF signal, which is applied from the gain controlled IF amplifier, is multiplied with the in-phase component of the VCO signal. The video demodulator is designed for low distortion and large bandwidth. The demodulator output signal passes an integrated low pass filter for attenuation of the residual vision carrier and is fed to the video amplifier. The video amplifier is realised by an operational amplifier with internal feedback and 8 MHz bandwidth (-3 dB). A standard dependent dc level shift in this stage delivers the same sync. level for positive and negative modulation. An additional noise clipping is provided. The video signal is fed to VIF-AGC and to the video output buffer. This amplifier with a 6 dB gain offers easy adaptation of the sound trap. For nominal video IF modulation the video output signal at Pin 12 is 2 Vpp.

5-2-6 Sound IF Amplifier and SIF-AGC

The SIF amplifier is nearly identical with the 3-stage VIF amplifier. Only the first amplifier stage exists twice and is switchable by a control voltage at Pin 3. Therefore with minimal external expense it is possible to switch between two different SAW filters. Both SIF inputs features excellent cross-talk attenuation and an input impedance which is independent from the switching condition. The SIF-AGC is related to the average level of AM- or FM-carrier and controls the SIF amplifier to provide a constant SIF signal to the AM demodulator and QPS mixer.

5-2-7 Quasi-Parallel-Sound (QPS) Mixer

The QPS mixer is realised by a multiplier. The SIF signal (FM or NICAM carrier) is converted to the intercarrier frequency by the regenerated picture carrier (quadrature signal) which is provided from the VCO. The intercarrier signal is fed via an output amplifier to Pin 24.

5-2-8 Standard Switch

To have equal polarity of the video output signal the polarity can be switched in the demodulation stage in accordance with the TV standard. Additionally a standard dependent dc level shift in the video amplifier delivers the same sync. level. In parallel to this, the correct VIF-AGC is selected for positive or negative modulated VIF signals. In the case of negative modulation (e.g., B/G standard) the AM output signal is switched off. For positive modulation (L standard) the AM demodulator and QPS mixer is active. This condition allows a parallel operation of the AM sound signal and the NICAM-L stereo sound.

5-2-9 L' Switch

With a control voltage at Pin 14 the VCO frequency can be switched for setting to the required L' value (L' standard). Also a fine adjustment of the L'-VCO center frequency is possible via a potentiometer. The L' switch is only active for positive modulated video IF-signals (standard switch in L mode).

5-2-10 Internal Voltage Stabiliser

The internal bandgap reference ensures constant performance independent of supply voltage and temperature.

5-3 Video - VCT description

5-3-1 Introduction

The VCT 38xxA includes complete video, display, and deflection processing. All processing is done digitally, the video front-end and video back-end are interfacing to the analogue world. Most functions can be controlled by software via I²C bus slave interface.

5-3-2 Video Front-end

This block provides the analogue interfaces to all video inputs and mainly carries out analogue-to-digital conversion for the following digital video processing. Most of the functional blocks in the front-end are digitally controlled (clamping, AGC, and clock-DCO). The control loops are closed by the Fast Processor ('FP') embedded in the video decoder.

5-3-3 Input Selector

Up to seven analogue inputs can be connected. Four inputs are for input of composite video or S-VHS luma signal. These inputs are clamped to the sync back porch and are amplified by a variable gain amplifier. Two chroma inputs can be used for connection of S-VHS carrier-chrominance signal. These inputs are internally biased and have a fixed gain amplifier.

5-3-4 Clamping

The composite video input signals are AC-coupled to the IC. The clamping voltage is stored on the coupling capacitors and is generated by digitally controlled current sources. The clamping level is the back porch of the video signal. S-VHS chrominance is also AC-coupled. The input pin is internally biased to the center of the ADC input range. Each channel is sampled at 10.125 MHz with a resolution of 8 bit.

5-3-5 Automatic Gain Control

A digitally working automatic gain control adjusts the magnitude of the selected baseband.

5-3-6 Digitally Controlled Clock Oscillator

The clock generation is also a part of the analogue front-end. The crystal oscillator is controlled digitally by the control processor. The clock frequency can be adjusted within ± 150 ppm. This adjustment is done in factory for every TV set.

5-3-7 Analogue Video Output

The input signal of the Luma ADC is available at the analogue video output pin (#11). The signal at this pin is buffered by a source follower. The output voltage is 2 V. The magnitude is adjusted with an AGC in 8 steps together with the main AGC.

5-3-8 Adaptive Comb Filter (VCT3834A only)

The adaptive comb filter is used for high-quality luminance/chrominance separation for PAL or NTSC signals. The comb filter improves the luminance resolution (bandwidth) and reduces interferences like cross-luminance and cross-color artefacts. The adaptive algorithm can eliminate most of the mentioned errors without introducing new artefacts or noise. The filter uses two line delays to process the information of three adjacent video lines. To have a fixed phase relationship of the colour subcarrier in the three channels, the system clock (20.25 MHz) is fractionally locked to the colour subcarrier. This allows the processing of all colour standards and substandards using a single crystal frequency. The CVBS signal in the three channels is filtered at the subcarrier frequency by a set of bandpass/notch filters. The output of the three channels is used by the adaptation logic to select the weighting that is used to reconstruct the luminance/chrominance signal from the 4 bandpass/notch filter signals. By using soft mixing of the 4 signals switching artefacts of the adaption algorithm are completely suppressed. The comb filter uses the middle line as reference, therefore, the comb filter delay is one line. If the comb filter is switched off, the delay lines are used to pass the luma/ chroma signals from the A/D converters to the luma/ chroma outputs. Thus, the comb filter delay is always one line.

5-3-9 Color Decoder

In this block, the standard luma/chroma separation and multi-standard colour demodulation is carried out. The colour demodulation uses an asynchronous clock, thus allowing a unified architecture for all colour standards.

The colour killer uses the burst-phase/ burst-frequency measurement to identify a PAL/NTSC or SECAM colour signal. For PAL/NTSC, the colour is switched off (killed) as long as the colour subcarrier PLL is not locked. For SECAM, the killer is controlled by the toggle of the burst frequency. The burst amplitude measurement is used to switch-off the colour if the burst amplitude is below a programmable threshold. Thus, colour will be killed for very noisy signals. The colour amplitude killer has a programmable hysteresis.

The burst-frequency measurement is also used for automatic standard recognition (together with the status of horizontal and vertical locking) thus allowing a completely independent search of the line and colour standard of the input signal. The following standards can be distinguished:

PAL B,G,H,I; NTSC M; SECAM; NTSC 44; PAL M; PAL N; PAL 60. In AV mode or when Prg No 0 is selected all the standards above are enabled by the controlling software. In INSTALL menu the controlling software enables PAL B,G, H,I and SECAM detection. The colour standard for each program number is stored in EEPROM. Outside INSTALL menu and for programmes numbers 1 to 99, the auto colour detection is disabled, the colour standard is recall from EEPROM and forced.

5-3-10 Horizontal Scaler (VCT3834A only)

The 4:2:2 YC r C b signal from the colour decoder is processed by the horizontal scaler. The scaler block allows a linear or nonlinear horizontal scaling of the input video signal in the range of 0.25 to 4. Nonlinear scaling, also called "Panoramavision", provides a geometrical distortion of the input picture. It is used to fit a picture with 4:3 format on a 16:9 screen by stretching the picture geometry at the borders. Also, the inverse effect can be produced by the scaler. The scaler contains a programmable decimation filter, a 1-line FIFO memory, and a programmable interpolation filter.

5-3-11 Video Sync Processing

To extract the sync information from the video signal, a linear phase low-pass filter eliminates all noise and video contents above 1 MHz. The sync is separated by a slicer; the sync phase is measured. A variable window can be selected to improve the noise immunity of the slicer. The phase comparator measures the falling edge of sync, as well as the integrated sync pulse. The sync phase error is filtered by a phase-locked loop that is computed by the Fast Processor. All timing in the front-end is derived from a counter that is part of this PLL, and it thus counts synchronously to the video signal. A separate hardware block measures the signal back porch and also allows gathering the maximum/minimum of the video signal. This information is processed by the FP and used for gain control and clamping. For vertical sync separation, the sliced video signal is integrated. The FP uses the integrator value to derive vertical sync and field information. The information extracted by the video sync processing is multiplexed onto the hardware front sync signal (FSY) and is distributed to the rest of the video processing system. The data for the vertical deflection, the sawtooth, and the East-West correction signal is calculated by the VCT 38xxA.

5-3-12 Display Processing

In the display processing the conversion from digital YC r C b to analogue RGB is carried out. In the luminance processing path, contrast and brightness adjustments and a variety of features, such as black-level expansion, dynamic peaking and soft limiting, are provided. In the chrominance path, the C r C b signals are converted to 4:4:4 format and filtered by a colour transient improvement circuit. The YC r C b signals are converted by a programmable matrix to RGB colour space. The digital OSD insertion circuit allows the insertion of a 5-bit OSD signal. The OSD signals and the display clock are synchronised to the horizontal flyback.

5-3-13 Chroma Transient Improvement

The intention of this block is to enhance the chroma resolution. A correction signal is calculated by differentiation of the colour difference signals. The differentiation can be selected according to the signal bandwidth, e.g. for PAL/NTSC/SECAM or digital component signals, respectively. The amplitude of the correction signal is adjustable. Small noise amplitudes in the correction signal are suppressed by an adjustable coring circuit. To eliminate 'wrong colours', which are caused by over and undershoots at the chroma transition, the sharpened chroma signals are limited to a proper value automatically.

5-3-14 Video Back-end

The digital RGB signals are converted to analogue RGBs using three video digital-to-analogue converters (DAC) with 10-bit resolution. An analogue brightness value is provided by three additional DACs. The adjustment range is 40 % of the full RGB range. Controlling the white-drive/analogue brightness and also the external contrast and brightness adjustments is done via the Fast Processor, located in the front-end. Control of the cutoff DACs is done via I 2 C bus registers. Finally cutoff and blanking values are added to the RGB signals. Cutoff (dark current) is provided by three 9-bit DACs. The adjustment range is 60 % of full scale RGB range. The analogue RGB-outputs are current outputs with current-sink characteristics. The maximum current drawn by the output stage is obtained with peak white RGB. An external half contrast signal can be used to reduce the output current of the RGB outputs to 50% . Cutoff and white-drive current measurement are carried out during the vertical blanking interval. They always use the small bandwidth setting.

5-3-15 CRT Measurement and Control

The display processor is equipped with an 8-bit ADC for all measuring purposes. The ADC is connected to the SENSE input pin. Cutoff and white-drive current measurement are carried out during the vertical blanking interval.

5-3-16 Average Beam Current Limiter

The average beam current limiter (BCL) uses the SENSE input for the beam current measurement. The BCL uses a different filter to average the beam current during the active picture. The filter bandwidth is approx. 2 kHz. The beam current limiter has an automatic offset adjustment that is active two lines before the first cutoff measurement line. The beam current limiter function is located in the front-end. The data exchange between the front-end and the back-end is done via a single-wire serial interface. The beam current limiter allows the setting of a thresh-old current. If the beam current is above the threshold, the excess current is low-pass filtered and used to attenuate the RGB outputs by adjusting the white-drive multipliers for the internal (digital) RGB signals, and the analogue contrast multipliers for the analogue RGB inputs, respectively. The lower limit of the attenuator is programmable, thus a minimum contrast can always be set. During the tube measurement, the ABL attenuation is switched off. After the white-drive measurement line it takes 3 lines to switch back to BCL limited drives and brightness.

5-3-17 Analogue RGB Insertion

The VCT 38xxA allows insertion of external analogue RGB signals. The RGB signal is key-clamped and inserted into the main RGB by the Fast-Blank switch. The external RGB input can be overlaid or underlaid to the digital picture. The external RGB signals can be adjusted independently as regards DC level (brightness) and magnitude (contrast). All signals for analogue RGB insertion (RIN, GIN, BIN, FBLIN) must be synchronised to the horizontal flyback, otherwise a horizontal jitter will be visible. The VCT 38xxA has no means for timing correction of the analogue RGB input signals. RGB signals are not digitalised and therefore cannot be processed by the picture scaler.

5-3-18 Fast-Blank Monitor

The presence of external analog RGB sources can be detected by means of a Fast-Blank monitor. With a special monitor logic it is possible to detect if there is an external RGB source active and if it is a full screen insertion or only a box. The monitor logic is connected directly to the FBLIN pin. The controlling software uses this information to disable all picture format using display scaler.

5-3-19 Vertical and East/West Deflection

The calculations of the vertical and East/West deflection waveforms is done by the internal Fast Processor (FP). The algorithm uses a chain of accumulators to generate the required polynomial waveforms. To produce the deflection waveforms, the accumulators are initialised at the beginning of each field. The initialisation values must be computed by the TV control processor and are written to the front-end once.

5-3-20 EHT Compensation

The vertical waveform can be scaled according to the average beam current. This is used to compensate the effects of electric high-tension changes due to beam current variations. EHT compensation for East/West deflection is done with an offset corresponding to the average beam current.

5-3-21 Reset Function

Reset of all VDP functions is performed by the RESQ pin. When this pin becomes active, all internal registers and counters are lost.

5-3-22 Standby and Power-On

The VDP does not have a standby mode. To disable all the analogue and digital video functions, it is necessary to switch off the supplies for analogue front-end (VSUP AF), analogue back-end (VSUP AB) and digital circuitry (VSUP D).

5-4- Microcontroller

5-4-1 Introduction

The TV controller basically consists of the CPU, RAM, ROM, and a number of peripheral modules.

For instance:

- a memory banking module is included to allow access to more than 64 kB memory.
- a bootloader software is included to allow in-system-downloading of external code to Flash memory via the I 2 C interface.

The TV controller runs the complete software necessary to control a TV set. The software includes control of the audio, video, OSD, and text processors on chip, as well, as control of external devices like tuner or stereo decoder.

Communication between the TV controller and external devices is done either via I 2 C bus interface or via programmable port pins. The TV Controller is clocked with $f_{OSC} = f_{XTAL} / 2$.

5-4-2 CPU

The CPU is fully compatible to WDC's W65C02 micro-processor. The processor has 8-bit registers/accumulator, an 8-bit data bus, and a 16-bit address bus.

5-4-3 μ - Controller I/O pin configuration and function

There exist different kinds of ports. The universal ports serve as digital I/O and have additional special input and output functions. A subset of the universal ports serves as input for the analogue-to-digital converter.

μ - Controller I/O pin configuration and function table

pin	name	configuration		description
		Stand by	TV ON	
1	Power	Push Pull Low	Push Pull High	Switch OFF / ON SMPS
2	AGC	High impedance	High impedance	Tuner AGC level input – For factory use only
5	Mod SW	High impedance	Push Pull	High = Negative modulation, Low = Positive modulation (L/L').
6	SECAM L'	High impedance	Push Pull	Low = L, High =L'
7	AFC	High impedance	High impedance	ADC input
8	IR	High impedance	High impedance	Interrupt input
9	SC1 SW	High impedance	High impedance	SCART 1 slow switching – ADC input
10	SC2 SW	High impedance	High impedance	SCART 2 slow switching – ADC input
61	Mute	Push Pull	Push Pull	High = Mute active
62	LED	Open Drain	Open Drain	
63	KB	High impedance	High impedance	Keyboard input – ADC input
64	OCP	High impedance	High impedance	Over Current Protection – Switch the set to Std by if < 2.

To reduce power consumption in stand by mode all ports not used are configured in high impedance mode.

5-4-4 Tuning

The AFC information is supplied by the demodulator IC, and becomes available on VCT pin 7 for controlling software. The controlling software uses this information for tuner frequency tracking (automatic following). The AFC window is typically between 50 KHz and 100 KHz.

The minimum frequency step of the tuner is 50 KHz.

This AFC function is disabled when a program is tuned using the direct frequency entry or after fine tuning adjustment. Therefore it is recommended to tune channel with the TV search function (manual or ATSS) or using the direct channel entry to enable the Automatic Frequency Control.

5-4-5 Automatic Format switching and WSS

When AUTO mode is selected by the user, the television will automatically select a mode for the user. The format information is supplied by SCART pin 8 level when in AV mode or by WSS data. The signal contains codes as defined in the WSS European Telecommunication Standard, ETS 300 294. Briefly, the signal is received at the beginning of line

23, in each frame. This is bi-phase encoded using a clock frequency of 5 MHz. In total, 14 data bits are available, in 4 groups. Group 1 contains the codes for the received format.

The mode chosen is defined by the following table. In effect the default mode is full screen.

The table below gives a summary of the FORMAT modes available (for WP895 and WP895F), and their given properties.

Format Name(OSD)	Zoom factor – TV with 16:9 CRT		Description	Application
	Vertical	Horizontal		
4:3	100%	75%	Picture is centred with black bars at the left and right hand side of the display	Standard 4/3 picture with 576 active lines
14:9	114%	87%	Picture is centred with black bars at the left and right hand side of the display	14:9 picture – letter box format with 504 active lines
ZOOM 14:9	114%	100%	Picture is displayed filling the full width of the screen by incorporating a small horizontal geometrical error (typically 8% linear)	14:9 picture – letter box format with 504 active lines
ZOOM 16:9	133%	100%	Picture is displayed filling the full screen (width and height)	16:9 picture – letter box format with 430 active lines
PANORAMA	100%	100%	Picture is displayed filling the full screen (width and height)	Used to fit a picture with 4:3 format on a 16:9 screen by stretching the picture geometry at the borders.

5-4-6 EXTERNAL source control logic

The following schematic, illustrates the logic of control for the two SCART connectors.

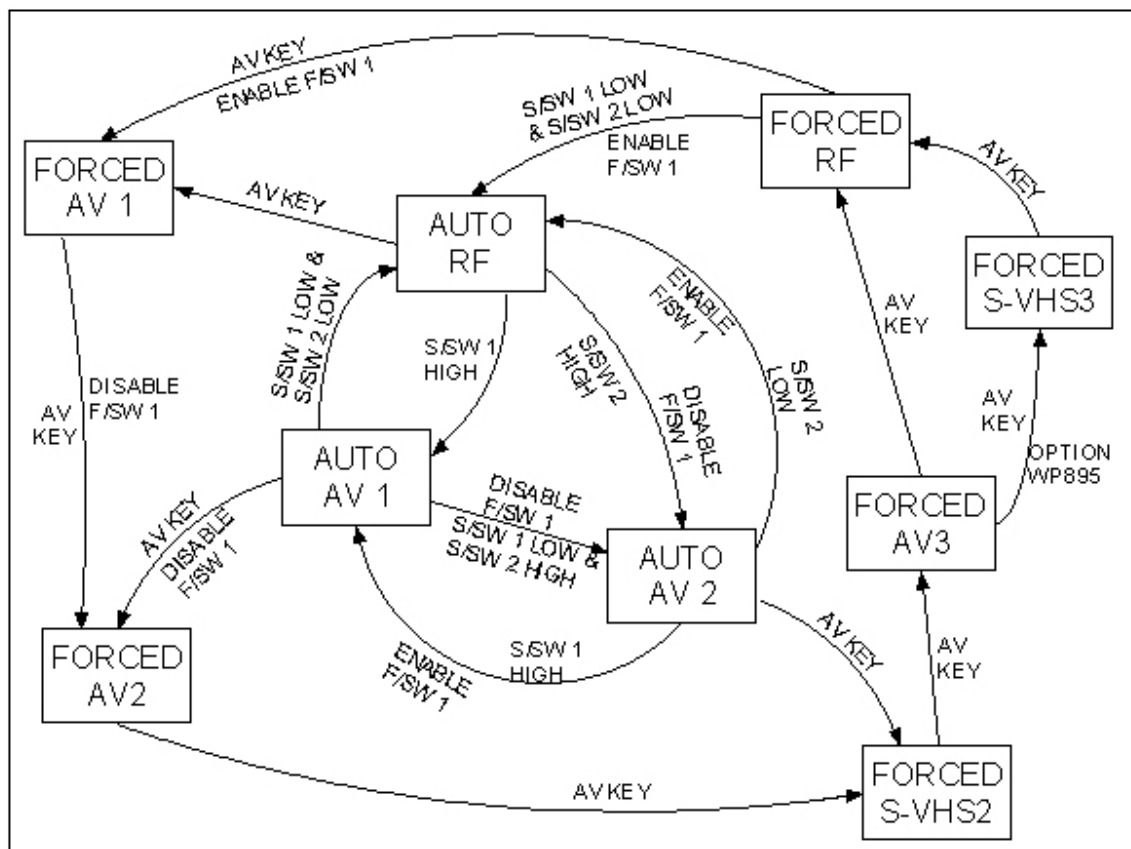

The terms used in the schematic are described below ;

1. AUTO represents a situation where the television has self-selected its picture source. This could be when the SCART SLOW SWITCHING pin has gone to a high state, and the AV 1 input is selected without the intervention of the user.
2. FORCED represents the change of source which has been commanded by the user (using the EXTERNAL button). The user always has priority, and can override the AUTO change of source by the television.
3. AV KEY represents the EXTERNAL button of the remote control, or on the television.
4. S/SW 1, or S/SW 2 represent the SLOW SWITCHING inputs of the first SCART (AV 1) or second SCART (AV 2), these each being pin number 8.
5. F/SW 1 represents the FAST SWITCHING input of the first SCART (AV 1), on pin number 16. The second SCART, AV 2, input does not possess a FAST SWITCHING input.

The HIGH state of a slow switching input represents the request from the external source to be selected by the television. Whether this is accepted or not depends on the position in the logic diagram. The general rule is that the user always has priority, so the use of the AV KEY will always result in a defined logic path being followed. Under certain circumstances, defined in the diagram, the change of state of a slow switching input will result in the automatic change of source by the television. This change, such as the change from RF broadcast to the AV 1 input,

can always be overridden by the user after the event.

Each line on the diagram, with its associated text, represents the exact conditions under which the change of state will occur. Sometimes this will be accompanied by another action which will be automatically performed by the television, being to either ENABLE or DISABLE F/SW 1.

5-4-7 Over Current Protection

In case of overload, the SMPS secondary voltages will drop. The voltage on pin 64 of microcontroller drops below a reference voltage (2.26V). The controlling software which continuously monitors this voltage will switch the set to stand by mode. To power on the set again the user must switch it off using the main power switch. Appropriate hysteresis guarantees a reliable operation.

5-5 Teletext Display

National character option bits C12, C13, C14 are transmitted in the page header of a given teletext page. The national option bits are intended to change (or exchange) 13 characters within the G0 character set, according to the needs of each national language. However, for Cyrillic and Greek languages, a major character set change (a change of character mapping) needs to be effected for correct display.

These codes represent, for a given broadcaster, the intended language that the teletext page should be displayed in. As there are only 3 bits, there are only 8 codes available to cover all the possible language combinations. This means that for a received code there are several possibilities meanings, and therefore several possibilities for display.

This is not as bad as it first seems, as we use the user-selected OSD language to identify the intention of the broadcaster. For example, a user wishing to see Russian teletext should select Russian OSD language, otherwise he would not have correct teletext display on the TV.

The table below allows the reader to understand the relationship between selected OSD language (which is under user control), the teletext language display (selected by national option bits in transmission page header) and the language mapping (either Latin or Greek/Cyrillic)

An example: For Greek teletext display, (if national option code 1 1 1 is received from the broadcaster), the user should select the Greek OSD language. Even if English, French, German, Italian, Spanish, Dutch, Danish, Finnish, Norwegian or Swedish OSD languages are selected, the teletext will be correctly displayed.

However, if Polish, Hungarian, Czech, Slovakian, Rumanian or Russian OSD are selected, Latin font mapping is selected. The consequence will be incorrect teletext display, with NO GREEK CHARACTERS DISPLAYED. Romanian national font options will be selected.

OSD Language	C 12	C 13	C 14	Teletext Language	ESC Teletext Language	Mapping
English, French, German, Italian, Spanish, Dutch, Danish, Finnish, Norwegian, Swedish, Greek	0	0	0	English	English	Latin
	0	0	1	German	German	Latin
	0	1	0	Swedish/Finnish	Swedish/Finnish	Latin
	0	1	1	Italian	Italian	Latin
	1	0	0	French	French	Latin
	1	0	1	Spanish	Spanish	Latin
	1	1	0	Turkish	Turkish	Latin
	1	1	1	English	Greek	Greek/Cyrillic
Polish, Hungarian, Czech, Slovakian, Rumanial	0	0	0	Polish	Polish	Latin
	0	0	1	German	German	Latin
	0	1	0	Hungarian	Hungarian	Latin
	0	1	1	Lettish/Lithuanian	Lettish/Lithuanian	Latin
	1	0	0	French	French	Latin
	1	0	1	Serb/Croat/Slovenian	Serb/Croat/Slovenian	Latin
	1	1	0	Czech/Slovak	Czech/Slovak	Latin
	1	1	1	Rumanian	Rumanian	LatinRussian
Russian	0	0	0	English	Serbian/Montenegrin	Greek/Cyrillic
	0	0	1	German	German	Latin
	0	1	0	Estonian	Estonian	Latin
	0	1	1	Lettish/Lithuanian	Lettish/Lithuanian	Latin
	1	0	0	English	Russian/Bulgarian	Greek/Cyrillic
	1	0	1	English	Ukrainian	Greek/Cyrillic
	1	1	0	Czech/Slovak	Czech/Slovak	Latin
	1	1	1	Rumanian	Rumanian	Latin

5-6 Sound processing

5-6-1 Analogue sound IF - input section

The input pins ANA_IN1+ and ANA_IN- offer the possibility to connect sound IF sources to the MSP 341xD. The analogue-to-digital conversion of the preselected sound IF signal is done by an A/D converter, whose output is used to control an analogue automatic gain circuit (AGC), providing an optimal level for a wide range of input levels.

5-6-2 Quadrature Mixers

The digital input coming from the integrated A/D converter may contain audio information at a frequency range of theoretically 0 to 9 MHz corresponding to the selected standards. By means of two programmable quadrature mixers, two different audio sources ; for example, NICAM and FM-mono, may be shifted into baseband position.

5-6-3 Phase and AM discrimination

The filtered sound IF signals are demodulated by means of the phase and amplitude discriminator block. On the output, the phase and amplitude is available for further processing.

AM signals are derived from the amplitude information, whereas the phase information serves for FM and NICAM demodulation.

5-6-4 NICAM decoder

In case of NICAM - mode, the phase samples are decoded according the DQPSK - coding scheme. The output of this block contains the original NICAM bitstream.

5-6-5 DSP section

All audio baseband functions are performed by digital signal processing (DSP). The DSP section controls the source and output selection, and the signals processing.

5-6-6 Sound Mode switching

In case of NICAM transmission, the controlling software reads the bit error rate and the operation mode from the NICAM Decoder. When the set is in "Auto detection" mode (default mode after ATSS) the controlling software sets automatically the sound mode (NICAM mono, NICAM Dual 1 or NICAM Dual 2) depending on the transmitted mode.

In the case of 2 Carrier FM transmission, the controlling software read the transmission mode and the signal quality level from the Stereo Detection Register. When the set is in "Auto detection" mode the controlling software automatically sets the sound mode (mono, Stereo, Dual 1, Dual 2) depending on the transmitted mode.

In "Auto detection" mode the controlling software evaluates the signal quality and automatically switches to the analogue sound carrier 1, if the transmission quality is too poor. To avoid unwanted automatic switching the threshold levels mono to stereo and stereo to mono are different.

In "forced mono " mode (Red OSD in status Display Window), the controlling software configures the MSP341xD to ~~display~~ the analogue (FM or AM) sound carrier 1, no matter the signal quality. The sound mode " forced " or " Autodetect" is stored for each programme.

5-7 Sound amplification

The TDA8944J (TDA8946J) is a stereo BTL audio amplifier capable of delivering 2 x 7 W (2 x 15 W) output power to an 8 W load at THD = 10%, using a 12 V power supply and an external heatsink. The voltage gain is fixed at 32dB.

With the three-level MODE input the device can be switched from 'standby' to 'mute' and to 'operating' mode. The TDA 8944J outputs are protected by an internal thermal shutdown protection mechanism and short-circuit protection.

5-7-1 Power amplifier

The power amplifier is a Bridge Tied Load (BTL) amplifier with an all-NPN output stage, capable of delivering a peak output current of 1.5 A.

The BTL principle offers the following advantages :

- Lower peak value of the supply current.
- The ripple frequency on the supply voltage is twice the signal frequency.
- No DC-blocking capacitor
- Good low frequency performance

5-7-2 Mode selection

The TDA894xJ has several functional modes, which can be selected by applying the proper DC voltage to pin MODE.

Mute : In this mode the amplifier is DC biased but not operational (no audio output). This allows the input coupling capacitors to be charged to avoid pop-noise. The device is in mute mode when $2.5\text{ V} < V_{\text{MODE}} < (V_{\text{CC}} - 1.5\text{ V})$.

Operating : In this mode the amplifier is operating normally. The operating mode is activated at $V_{\text{MODE}} < 0.5\text{ V}$.

5-8 Vertical deflection

The vertical driver circuit is a bridge configuration. The deflection coil is connected between the output amplifiers, which are driven in phase opposition. The differential input circuit is voltage driven. The input circuit is especially intended for direct connection to driver circuits which deliver symmetrical current signals, but is also suitable for asymmetrical currents. The output current of these devices is converted to voltages at the input pins via resistors R350 and R351. The differential input voltage is compared with the output current through the deflection coils measured as voltage across R398, which provides internal feedback information. The voltage across R398 is proportional to the output current.

5-8-1 Flyback voltage

The flyback voltage is determined by an additional supply voltage V_{fb} . The principle of operation with two supply voltages (class G) makes it possible to fix the supply voltage V_p optimum for the scan voltage and the second supply voltage V_{fb} optimum for the flyback voltage. Using this method, very high efficiency is achieved. The supply voltage V_{fb} is almost totally available as flyback voltage across the coil, this being possible due to the absence of a coupling capacitor.

5-8-2 Protection

The output circuit has protection circuits for :

- Too high die temperature
- overvoltage of output stage A

5-8-3 Guard circuit

The guard signal is not used.

5-8-4 Damping resistor

For HF loop stability a damping resistor (R331) is connected across the deflection coil.

5-8-5 EAST-WEST Amplifier (TDA8358J)

The East-West amplifier is current driven. It can only sink currents of the diode modulator circuit. A feedback resistor R397 is connected between the input and output of this inverting amplifier in order to convert the East-West correction input into an output voltage.

5-9 Power supply (STR F6654)

5-9-1 STR-F6654 general description

The STR-F6654 is an hybrid IC with a build-in MOSFET and control IC, designed for flyback converter type switch mode power supply applications.

5-9-2 Power supply primary part operations

An oscillator generates pulses signals which turn on and off a MOSFET transistor.

5-9-2-1 Start-up circuit : V_{IN}

The start-up circuit is used to start and stop the operation of the control IC, by detecting a voltage appearing at V_{IN} pin (pin 4).

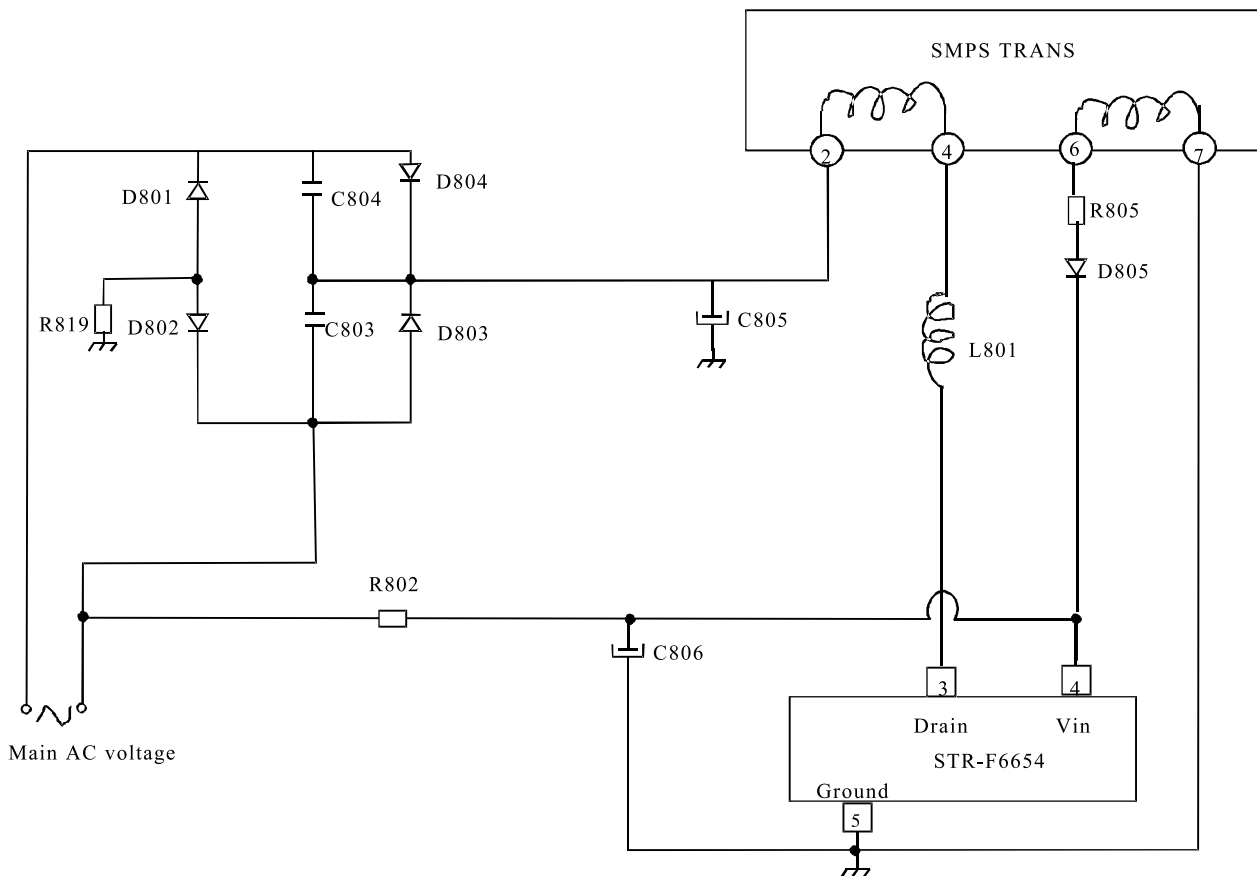

Fig : Power supply start-up circuit

When the power switch is pushed on, V_{IN} increases slowly. During this time, C806 is charged through R802.

As soon as V_{IN} reaches 16V, the STR-F6654 control circuit starts operating. Then, V_{IN} is obtained by smoothing the winding voltage which appears between pin6 and pin7 of the SMPS transformer.

As this winding voltage does not increase to the set voltage immediately after the control circuit starts operating, V_{IN} starts dropping. However, as this winding voltage reaches the set value before V_{IN} voltage drops to the shutdown voltage (at 11V), the control circuit continues operating (see below V_{IN} voltage at start-up). R805 resistor prevents that V_{IN} pin voltage varies according to the secondary side output current.

V_{IN} must be set higher than the shutdown voltage ($V_{IN}(\text{off}) = 11V_{\text{max}}$) and lower than the O.V.P. (overvoltage protection) operating voltage ($V_{\text{OVP}} = 20.5V_{\text{min}}$)

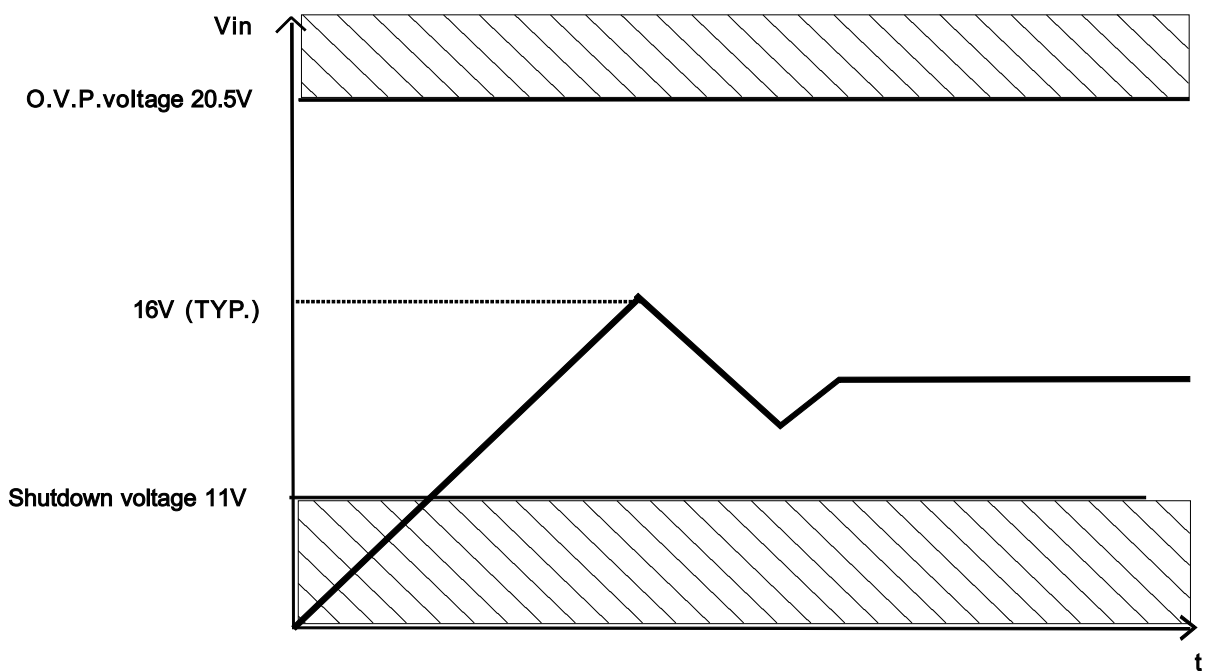

Fig : Waveform of Vin pin voltage at start

5-9-2-2 STR-F6654 oscillating operation

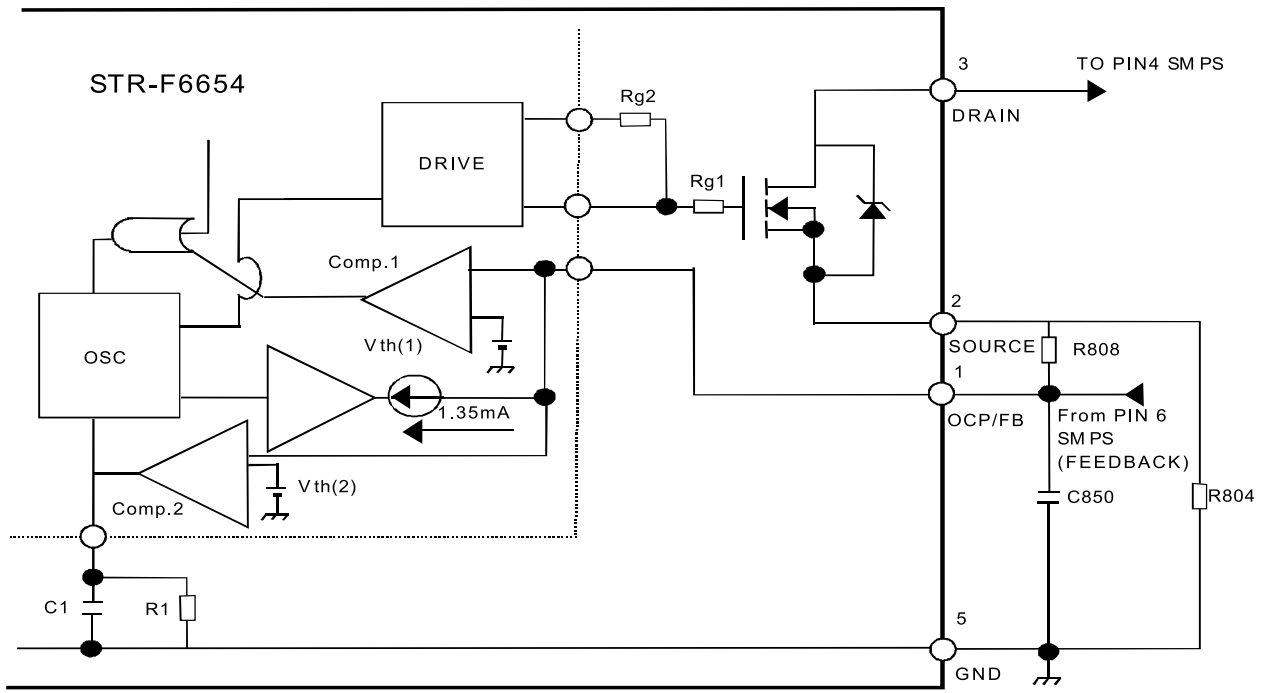

Fig : Oscillating operation

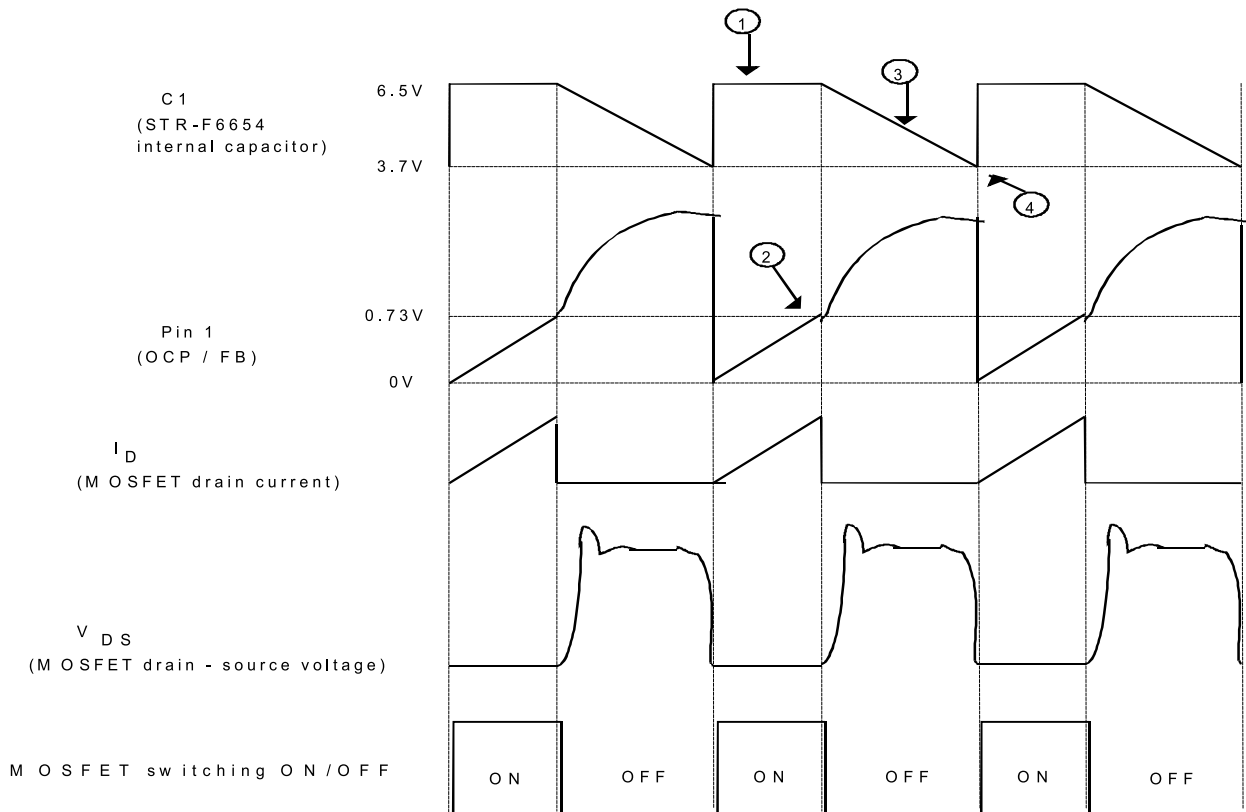

Fig : Waveforms during oscillating operation

- ① When the MOSFET is ON, the STR-F6654 internal capacitor C1 is charged at the constant voltage 6.5V. At the same time, the voltage at pin 1 (OCP / FB) increases with the same waveform as the MOSFET drain current.
- ② When the pin 1 voltage reaches the threshold voltage $V_{TH1} = 0.73V$, the STR-F6654 internal comparator 1 starts operating. The STR-F6654 internal oscillator is inverted and the MOSFET turns OFF.
- ③ When the MOSFET turns OFF, charging of STR-F6654 internal capacitor C1 is released and C1 starts discharging by the STR-F6654 internal resistance R1. So, C1 voltage starts falling in accordance with the gradient regulated by the constant discharging time of C1 and R1. So, this means that the fixed time determined by C1 and R1 is the OFF-time of the MOSFET.
- ④ When C1 voltage falls to around 3.7V, the STR-F6654 internal oscillator is reversed again and the MOSFET turns ON. C1 is quickly charged to around 6.5V

The MOSFET continues to oscillate by repeating the above procedure.

5-9-2-3 STR-F6654 protection circuits

- **overcurrent protection function (OCP)**

Overcurrent protection is performed pulse by pulse detecting at STR-F6654 pin 1 (OCP) the peak of the MOSFET drain current in every pulse.

- **latch circuit**

This circuit sustains an output low from the STR-F6654 internal oscillator and stops operation of the power supply when overvoltage protection (OVP) and thermal shutdown (TSD) circuit are under operation

- **thermal shutdown circuit (TSD)**

This circuit triggers the latch circuit when the frame temperature of STR-F6654 IC exceeds 140°C

- **overvoltage protection circuit (OVP)**

This circuit triggers the latch circuit when the V_{in} voltage exceeds 22V (typ.)

5-10 TV start-up, TV normal run and stand by mode operations

5-10-1 TV start-up operations

*Schematic diagram for start-up operations

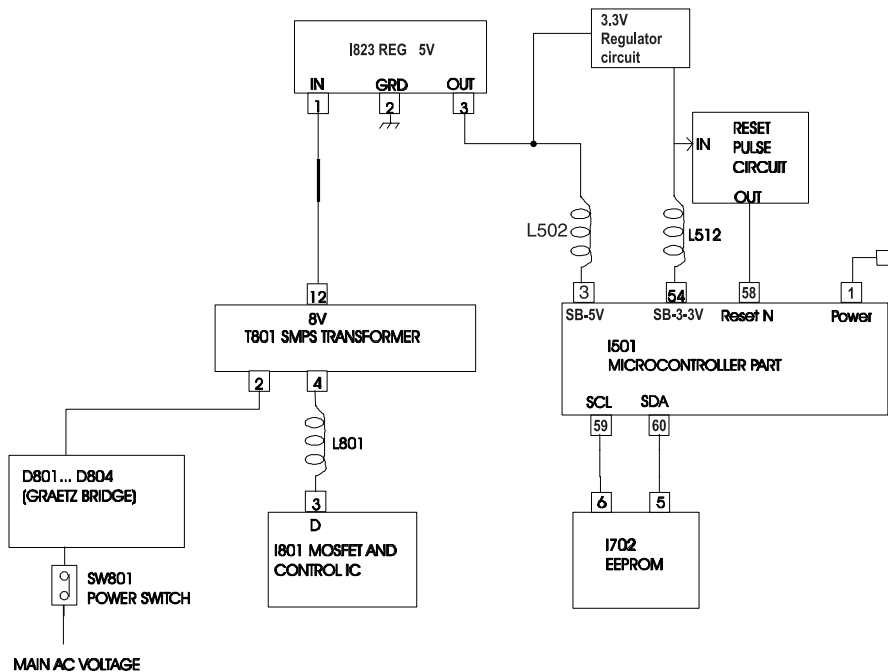

Start-up operations

*TV start-up and microcontroller initialisation

- When SW801 power switch is pushed, main AC voltage is applied to T801 transformer (after rectification by D801... D804 diodes). Then, T801 SMPS transformer starts operating and supplies DC voltage to I823 (5V regulator) and to 3.3v Regulator circuit.
- These regulators provide 5V / 3.3V DC voltage to I501 microcontroller power supply pins (pin 3 / pin 54) and to the reset pulse circuit which provides reset pulse to I501 microcontroller reset pin (pin 58).
- Then, the microcontroller starts its initialisation. Its power pin (pin 1) is set to high which allows delivery of power supply voltages (123V~143V, 8V, 5V...). At this step, all IC's start working but no picture appears on screen: I501 IC doesn't provide horizontal drive voltage.
- Then, the microcontroller consults I702 EEPROM via I2C bus to know the last TV set mode (normal run mode or stand-by mode) before switching off.

- . If the TV set was on normal run mode before switching off, the microcontroller delivers horizontal drive voltage at pin 24 and picture appears on screen.
- . If the TV set was on stand-by mode before switching off, the microcontroller switches TV set to stand-by mode, decreasing power pin voltage (pin 1).

5-10-2 TV normal run and stand-by mode operations

Depending on remote control commands, I501 microcontroller part pin 1 (power) is set to :

- high for normal run mode
- low for stand-by mode

a) TV on normal run mode

* I501 microcontroller part pin 1 (power) effect

I501 microcontroller part pin 1 (power) is connected to the following circuit :

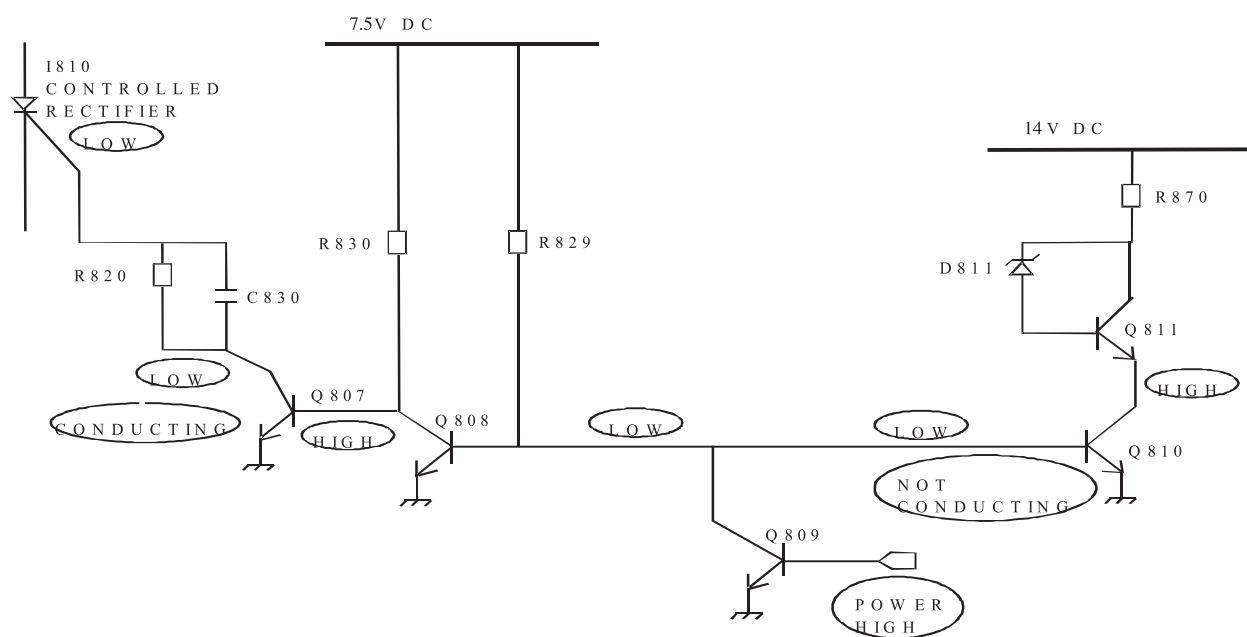

Fig : I501 microcontroller part pin 1 (POWER) effect

On normal run mode, I501 microcontroller pin 1 (power) is set to high

- So, I810 controlled rectifier is not conducting

- Q809 is conducting. So, Q808 is not conducting and Q807 is conducting
- So, Q807 collector is connected to the ground and I810 controlled rectifier gate pin is set to low (no conducting)

- So, current from 14V DC voltage (from T801 SMPS transformer pin 13) does not flow through Q811 and Q810 transistors but flows through I806 IC error amplifier

- Q809 is conducting. So, Q810 is not conducting and no current flows from Q810 collector to the ground
- Therefore, the power circuit diagram is the following one :

* power supply circuit diagram during TV set normal run

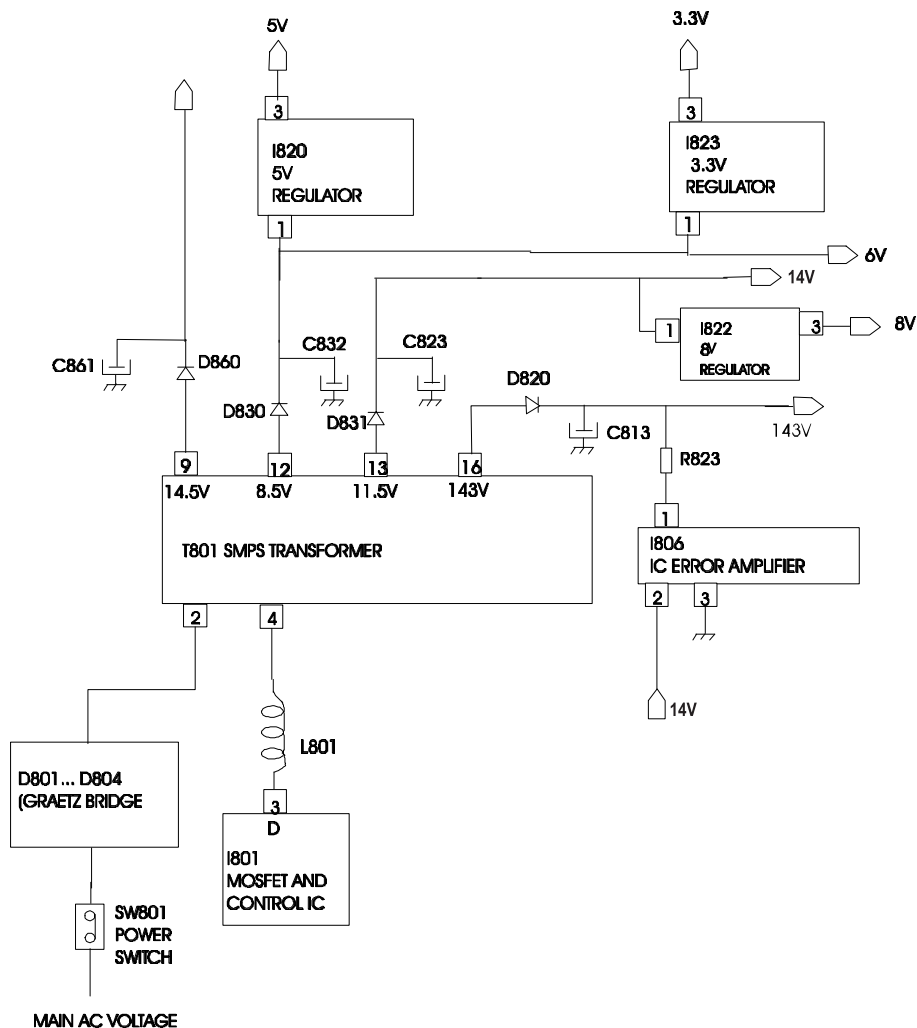

Fig : Power supply operation during TV set normal run

* power supply functioning during TV set normal run mode

- I801 transmits controlled pulses to T801 which generates DC voltages after rectifications by secondary part diodes and electro capacitors (by example by D820 and C813 on 143V supply voltage line).

- 8V, 5V, 3.3V supply voltage lines have stabilized voltages obtained by I820, I822, I823 voltage regulators.

- On 143V supply voltage line, R823 resistor has been chosen to reach exact DC voltage required on this line.

- 143V supply voltage line includes an IC error amplifier (I806) which corrects unexpected DC voltage variations on this line.

* power supply IC delivery during TV set normal run

power supply line	IC power supply delivery	Remarks
143V	FBT	FBT supplies 43V to I301 vertical IC FBT supplies 43V to T401 H-Drive FBT supplies 12V to I301 vertical IC FBT supplies 33V to the tuner FBT supplies 188V to I901 video amplifier pin 6
14.5V	I602 sound amplifier pins 3-16	
14V	T401 H- drive	
8V	I601 Sound Demod pins 38-39-40	
5V	I101 If IC Pin 23 I501 Main IC pins 3-15-45 I601 Sound Demod pins 7-18-57 I702 EEPROM pin 8 tuner	
3.3V	I501 Main IC pin 25	
S/B 5V	I703 IR receiver pin 1 I501 Main IC Pin 3	
S/B 3.3V	I501 Main IC Pin 54	

b) TV set on stand-by mode

* TV set circuit diagram on stand-by mode

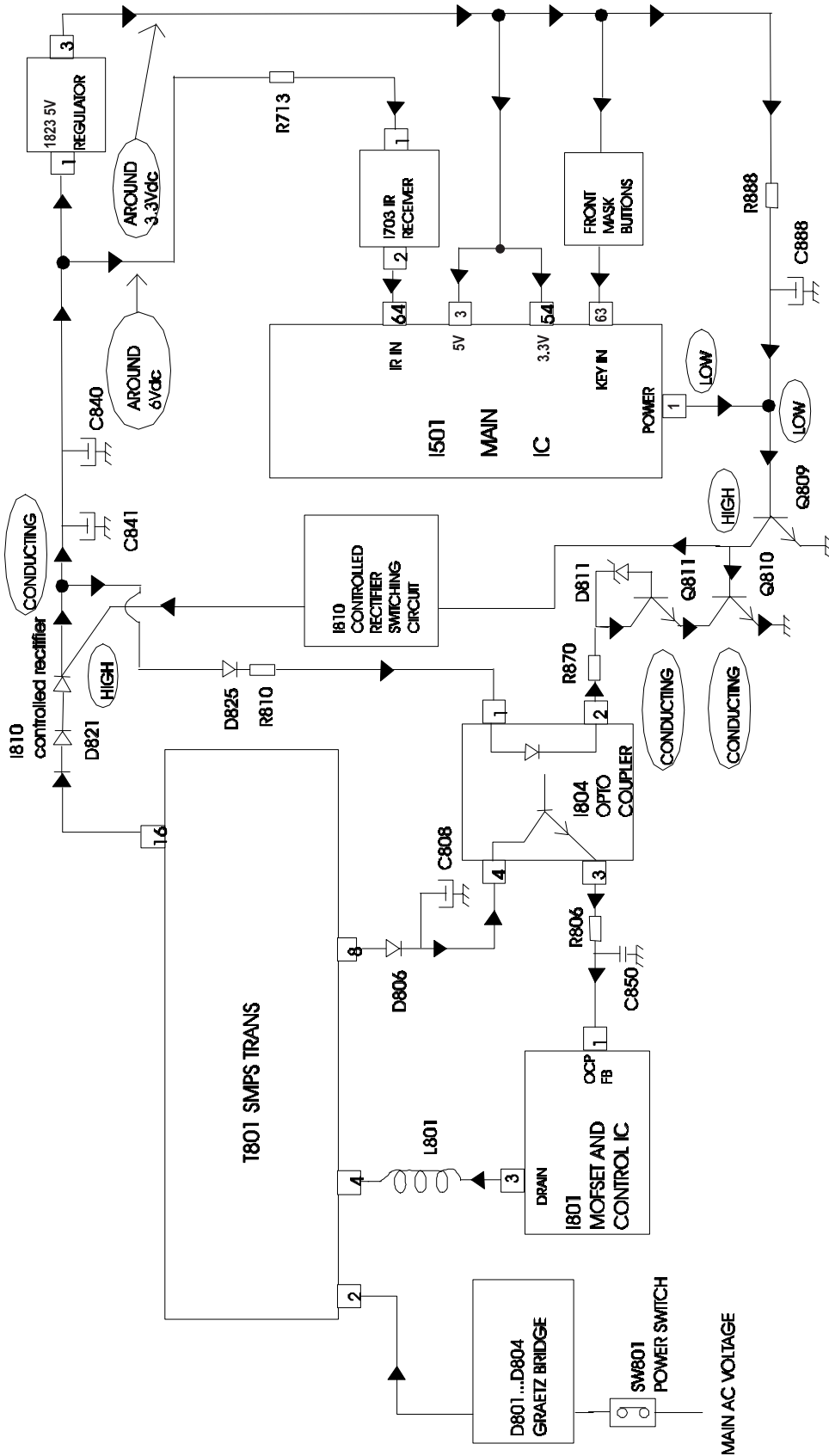

Fig. : Power supply operation in stand - by mode

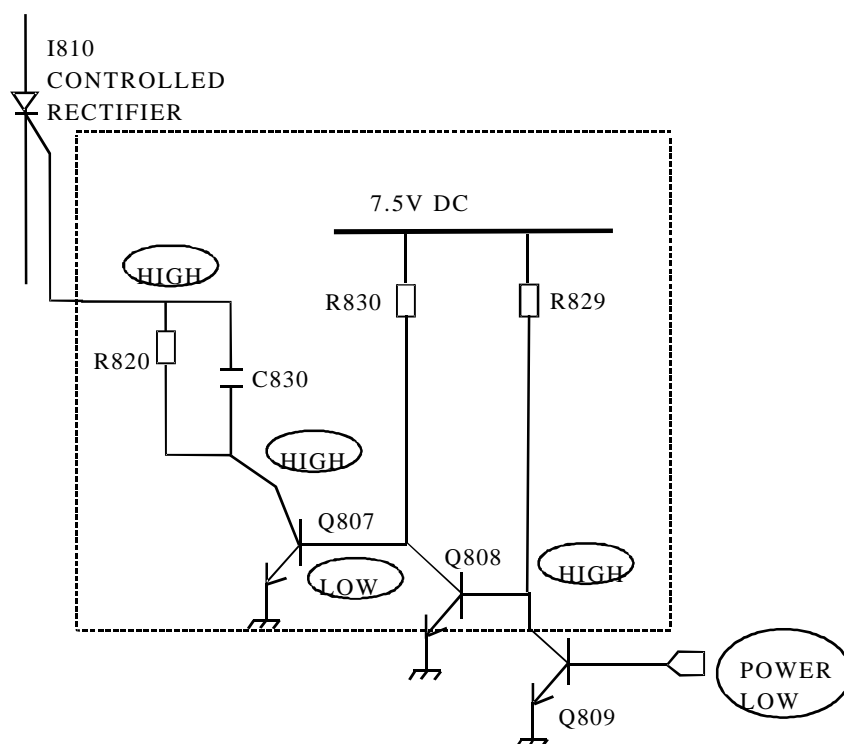

Fig : I810 controlled rectifier switching circuit

* TV set stand-by mode operations

- On stand-by mode, I501 microcontroller pin 1 (power) is set to low.
- So, Q809 collector is set to high.
- Then, I810 controlled rectifier gate pin is set to high and I810 is conducting.
- So, current flows from pin 16 SMPS transformer to the ground via I804 optocoupler and Q810 and Q811 transistors (which are conducting).
- In these conditions, I801 delivers pulses on light mode and T801 produces voltages with reduced power.
- As I810 is conducting, current flows also from pin 16 SMPS transformer to I823 (5V / 3.3V regulator) for I501 μ com, IR receiver and front mask buttons supply voltage (then, remote control or front mask buttons can be activated to leave stand-by mode).

Service Manual WP-895/895F, CP885/885F, CP485F

6. Service Parts List

(DWX - 28W5)

CAUTION

"△" Parts recommended for stock.

"®" Safety critical componen, Replace only with genuine Deawoo safety parts.

LOC	PART CODE	PART NAME	DESCRIPTION	REMARK	LOC	PART CODE	PART NAME	DECSRIPTION	REMARK
M211	4852158911	COVER BACK	HIPS GY		PW001	4857417700	TERM CLAMP	PT-01-T3	
M211D	4857817611	CLOTH BLACK	FELT 200X20X0.7		ZZ290	PTMPMSX28W5ZF	PCB MAIN MANUAL AS	DWX-28W5ZZF	
M541	4855415800	SPEC PLATE	150ART P/E FILM (C/TV)		10	2193100801	SOLDER BAR	SN:PB=63:37 3PI(NO FLUX)	
M201A	4857818701	CLOTH BLACK	FELT T0.7 L=250 W=15		40	2291050314	FLUX SOLVENT	IM-1000	
M201B	4857818702	CLOTH BLACK	FELT T0.7 L=350 W=15		20	2193011101	SOLDER WIRE	RS 60-1.2 1.6A	
M211A	7172401612	SCREW TAPPTITE	TT2 TRS 4X16 MFZN BK		30	2291050617P	FLUX SOLDER	CF-329D	
M211B	7178301212	SCREW TAPPTITE	TT2 WAS 3X12 MFZN BK		50	2291140501	WAX COVER	60G/PC	
M281	4852822601	DOOR	PC GY		60	2291051001	FLUX KILLER	KFT-7	
M352	97P4602700	CLAMP CORD	NYLON 66 BLK 5280N		C106	CEXF1H221V	C ELECTRO	50V RSS 220MF (10X16) TP	
M391A	7172401612	SCREW TAPPTITE	TT2 TRS 4X16 MFZN BK		C118	CMCN1J474K	C MYLAR	63V 0.47MF MKT	
M481	4854859511	BUTTON POWER	ABS GY		C315	CEXF2A470V	C ELECTRO	100V RSS 47MF (10X16) TP	
M481A	4856716000	SPRING	SWPA PIE0.5		C402	CMYH3C123J	C MYLAR	1.6KV 0.012MF J	
M491	4854934001	BUTTON	ABS BK		C408	CMYE2G304J	C MYLAR	400V 0.3MF J (PL)	
M491A	7178301011	SCREW TAPPTITE	TT2 WAS 3X10 MFZN		C415	CEXF2E479V	C ELECTRO	250V RSS 4.7MF (10X16)TP	
M501	4855059901	DECO CTRL	PVC T0.25		C430	CCXB3D681K	C CERA	2KV B 680PF K (TAPPING)	
M561	4855617401	MARK BRAND	AL (SILVER)		C431	CMXB2G472J	C MYLAR	400V 4700PF J TP	
M681	4856812001	TIE CABLE	NYLON66 DA100		C440	CMXE2G273J	C MYLAR	400V PU 0.027MF J (T	
M682	4856816300	CLAMP WIRE	NYLON 6 (V0)		C499	CEYD1H689W	C ELECTRO	50V RHD 6.8MF (16X35.5)	
M791	4857923300	DOOR LOCK	LA701(KIFCO)		C604	CEXF1E102V	C ELECTRO	25V RSS 1000MF (13X20) TP	
SP01A	7172401212	SCREW TAPPTITE	TT2 TRS 4X12 MFZNCK		C801	CL1JB3474K	C LINE ACROSS	AC250V 0.47MF U/C/SNDF/SV	△
SP02A	7172401212	SCREW TAPPTITE	TT2 TRS 4X12 MFZNCK		C805	CEYN2G181P	C ELECTRO	400V LHS 180MF (25X35)	
V901A	4856215402	WASHER RUBBER	CR T2.0		C811	CCYR3D681K	C CERA	2KV R 680PF K 125C	
V901B	4856015800	SCREW CRT FIX	L=27		C812	CH1AFE472M	C CERA AC	4KV 4700PF M KX DE1610	△
M201	4852077111	MASK FRONT	HIPS GY		C813	CEXF2E101V	C ELECTRO	250V RSS 100MF 18X35.5	
M801	4858058900	BOX CARTON	DW-3		C814	CEYF2E470V	C ELECTRO	250V RSS 47MF (16X25)	
M811	4858196500	PAD	EPS 28W5		C820	CCYR3A471K	C CERA	1KV 470PF K 125C	
M822	4858215600	BAG P.E	PE FOAM t0.5x1600x1270		C823	CEXF1E102V	C ELECTRO	25V RSS 1000MF (13X20) TP	
V901	4859628160	CRT	W66ECK001X13	△ ®	C832	CEXF1E102V	C ELECTRO	25V RSS 1000MF (13X20) TP	
ZZ132	58G0000151	COIL DEGAUSSING	DC-28SFW	△	C840	CEXF1C222V	C ELECTRO	16V RSS 2200MF(13X25)TP	
ZZ131	4851902110	CRT GROUND NET	24/5/0.12-1560+4850702029		C841	CEXF1C332V	C ELECTRO	16V RSS 3300MF	
ZZ100	48B4846G22	TRANSMITTER REMOCON	R-46G22	®	C861	CEXF1E102C	C ELECTRO	25V RUS 1000MF 13X20 TP	
00030	4850Q00910	BATTERY	R03/NN		C866	CCYR3A471K	C CERA	1KV 470PF K 125C	
M681	4856812400	BAND	18MM X 3M		C900	CCXB3D102K	C CERA	2KV B 1000 PF K (TAPPING)	
M801	4858058900	BOX CARTON	DW-3		C910	CEXF2E479V	C ELECTRO	250V RSS 4.7MF (10X16)TP	
M811	4858196500	PAD	EPS 28W5		C997	CEXF2E100V	C ELECTRO	250V RSS 10MF (10X20) TP	
M822	4858215600	BAG P.E	PE FOAM t0.5x1600x1270		D403	DBY228—	DIODE	BY228	
0000A	4857027800	HEAT SINK	AL EX		D404	DBYW76—	DIODE	BYW76	
0000B	7174300811	SCREW TAPPTITE	TT2 RND 3X8 MFZN		D820	DBYW76—	DIODE	BYW76	
SP01	4858311110	SPEAKER	12W 8 OHM SP-58126F	®	D860	DBYW76—	DIODE	BYW76	
SP02	4858311110	SPEAKER	12W 8 OHM SP-58126F	®	F801	5FSCB4022R	FUSE CERA	SEMKO F4AH 4A 250V MF51	△

Service Manual WP-895/895F, CP885/885F, CP485F

LOC	PART CODE	PART NAME	DESCRIPTION	REMARK	LOC	PART CODE	PART NAME	DESCRIPTION	REMARK
G900	4SG0D00103	SPARK GAP	S-23 900V-1.5KV		Q401B	7174300811	SCREW TAPPTITE	TT2 RND 3X8 MFZN	
I101	1TDA4470M-	IC IF	TDA4470-M		R398	RD-2Z109J-	R CARBON FILM	1/2 1 OHM J	
I301	1TDA8358J-	IC VERTICAL	TDA8358J	Ⓜ	R399	RS02Y180JS	R M-OXIDE FILM	2W 18 OHM J SMALL	
I301A	4857028227	HEAT SINK	AL EX ANODIZING		R415	RS02Y102JS	R M-OXIDE FILM	2W 1K OHM J SMALL	
I301B	7174301011	SCREW TAPPTITE	TT2 RND 3X10 MFZN		R450	RS02Y223JS	R M-OXIDE FILM	2W 22K OHM J SMALL	
I501	1DW3834AE1	IC MICOM	DW3834A-AE1	Ⓜ	R801	DPC7R0M290	POSISTOR	96709 (PHILIPS)	
I601	1MSP3410G-	IC SOUND PROCESSOR	MSP3410G	Ⓜ	R802	RS02Y753JS	R M-OXIDE FILM	2W 75K OHM J SMALL	
I602	1TDA8946J-	IC AUDIO	TDA8946J	Ⓜ	R803	RS02Y473JS	R M-OXIDE FILM	2W 47K OHM J SMALL	
I602A	4857028215	HEAT SINK	AL EX NO ANODOZING		R804	RF02Y228K-	R FUSIBLE	2W 0.22 OHM K	
I602B	7174301011	SCREW TAPPTITE	TT2 RND 3X10 MFZN		R819	RX10T339J-	R CEMENT	10W 3.3 OHM J TRIPOD	Ⓜ
I702	1AT24C16PC	IC MEMORY	AT24C16-10PC	Ⓜ	R850	RS02Y229JS	R M-OXIDE FILM	2W 2.2 OHM J SMALL	
I703	1TSOP1238W	IC PREAMP	TSOP1238W11	Ⓜ	R906	RF01Y479J-	R FUSIBLE	1W 4.7 OHM J	
I801	1STRF6654-	IC SMPS	STR-F6654	Ⓜ	SCT1	4859303530	SOCKET CRT	PCS629-03C	⚠
I801A	4857027701	HEAT SINK	AL EX		SF1	5PK3953M—	FILTER SAW	K3953M	
I801B	7174300811	SCREW TAPPTITE	TT2 RND 3X8 MFZN		SF2	5PK9650M—	FILTER SAW	K9650M	
I804	1KP1010C—	IC PHOTO COUPLER	KP-1010C	⚠	SW801	5S40101143	SW PUSH	PS3-22SP (P.C.B)	
I806	1SE130N—	IC	SE130N	Ⓜ	T401	50D19A1—	TRANS DRIVE	TD-19A1	
I810	TX0202DA—	THYRISTOR	X0202DA	Ⓜ	T402	50H0000225	FBT	1342.0040B	⚠, Ⓜ
I820	1KA7805—	IC REGULATOR	KA7805		T801	50M4936B2-	TRANS SMPS	2094.0057B	⚠
I822	1KA7808—	IC REGULATOR	KA7808		U100	4859722430	TUNER VARACTOR	UV1316/AIG-3	Ⓜ
I823	1KA7805—	IC REGULATOR	KA7805		X501	5XE20R250E	CRYSTAL QUARTZ	HC-49/U 20.2500MHZ 30PPM	
I901	1TDA6107Q-	IC VIDEO	TDA6107Q	Ⓜ	X601	5XE18R432E	CRYSTAL QUARTZ	HC-49/U 18.43200MHZ 30PPM	
I901A	4857031100	HEAT SINK	A1050P-H24 T2.0		Z153	5PYXT5R5MB	FILTER CERA	XT5.5MB	
I901B	7174300811	SCREW TAPPTITE	TT2 RND 3X8 MFZN		ZZ200	PTMPJBX28W5LF	PCB MAIN EYE LET AS	DWX-28W5ZLF	
JP01	4859102130	JACK EARPHONE	YSC-1537		C402	4856310300	EYE LET	BSR T0.2 (R1.6)	
JPA1	4859200401	SOCKET RGB	SR-21A1 (ANGLE TYPE)		C404	4856310300	EYE LET	BSR T0.2 (R1.6)	
JPA2	4859200401	SOCKET RGB	SR-21A1 (ANGLE TYPE)		C408	4856310300	EYE LET	BSR T0.2 (R1.6)	
JPA3	4859108450	JACK PIN BOARD	YSC03P-4120-14A		C805	4856310600	EYE LET	BSR 2.3(R2.3)	
L150	58E0000041	COIL AFT	TRF-A005		D403	4856310600	EYE LET	BSR 2.3(R2.3)	
L380	58C0000120	COIL CHOKE	CH-100Q		D404	4856310600	EYE LET	BSR 2.3(R2.3)	
L381	58C0000120	COIL CHOKE	CH-100Q		I301A	4856310600	EYE LET	BSR 2.3(R2.3)	
L401	58H0000067	COIL H-LINEARITY	TRL-240B		I602A	4856310600	EYE LET	BSR 2.3(R2.3)	
L402	58C0000122	COIL CHOKE	CH-401B		I801A	4856310600	EYE LET	BSR 2.3(R2.3)	
L802	58C9430599	COIL CHOKE	AZ-9004Y(94MH)		L401	4856310300	EYE LET	BSR T0.2 (R1.6)	
LF801	5PLF24A1—	FILTER LINE	LF-24A1		Q401	4856310300	EYE LET	BSR T0.2 (R1.6)	
M351	4858900002	HOLDER LED AS	LH-3P		R819	4856310300	EYE LET	BSR T0.2 (R1.6)	
P102	4859231620	CONN WAFER	YW025-03		SW801	4856310600	EYE LET	BSR 2.3(R2.3)	
P401	4850706N08	CONNECTOR	6PIN 500MM BOARD IN TYPE		T402	4856310600	EYE LET	BSR 2.3(R2.3)	
P402	4859240120	CONN WAFER	YFW500-06		T801	4856310300	EYE LET	BSR T0.2 (R1.6)	
P501	4850705N14	CONNECTOR	BIC-05T-25T+ULW=500		ZZ200	PTMPJRX28W5LF	PCB MAIN RADIAL AS	DWX-28W5ZLF	
P601	4859231720	CONN WAFER	YW025-04		C102	CEXF1E470V	C ELECTRO	25V RSS 47MF (5X11) TP	
P702	4859231720	CONN WAFER	YW025-04		C110	CXCH1H150J	C CERA	50V CH 15PF J (TAPPING)	
P801	4859242220	CONN WAFER	YFW800-02		C117	CEXF1H229V	C ELECTRO	50V RSS 2.2MF (5X11) TP	
P802	4859242220	CONN WAFER	YFW800-02		C121	CEXF1H100V	C ELECTRO	50V RSS 10MF (5X11) TP	
P903	4859238620	CONN WAFER	YPW500-02		C122	CEXF1H100V	C ELECTRO	50V RSS 10MF (5X11) TP	
Q401	T2SD1880—	TR	2SD1880	Ⓜ	C152	CEXF1H100V	C ELECTRO	50V RSS 10MF (5X11) TP	
Q401A	4857024500	HEAT SINK	AL EX		C153	CEXF1H479V	C ELECTRO	50V RSS 4.7MF (5*11) TP	

Service Manual WP-895/895F, CP885/885F, CP485F

LOC	PART CODE	PART NAME	DESCRIPTION	REMARK	LOC	PART CODE	PART NAME	DESCRIPTION	REMARK
C156	CBXF1H104Z	C CERA SEMI	50V F 0.1MF Z (TAPPING)		C623	CEXF1H109V	C ELECTRO	50V RSS 1MF (5X11) TP	
C157	CEXF1H100V	C ELECTRO	50V RSS 10MF (5X11) TP		C624	CEXF1H109V	C ELECTRO	50V RSS 1MF (5X11) TP	
C158	CBXF1H104Z	C CERA SEMI	50V F 0.1MF Z (TAPPING)		C625	CEXF1E101V	C ELECTRO	25V RSS 100MF (6.3X11) TP	
C164	CEXF1E470V	C ELECTRO	25V RSS 47MF (5X11) TP		C626	CEXF1E101V	C ELECTRO	25V RSS 100MF (6.3X11) TP	
C301	CMXM2A224J	C MYLAR	100V 0.22MF J BULK		C629	CBXF1H104Z	C CERA SEMI	50V F 0.1MF Z (TAPPING)	
C305	CEXF1E221V	C ELECTRO	25V RSS 220MF (8X11.5) TP		C630	CEXF1E470V	C ELECTRO	25V RSS 47MF (5X11) TP	
C313	CMXM2A104J	C MYLAR	100V 0.1MF J TP		C634	CEXF1H100V	C ELECTRO	50V RSS 10MF (5X11) TP	
C320	CBXF1H104Z	C CERA SEMI	50V F 0.1MF Z (TAPPING)		C635	CCXB1H102K	C CERA	50V B 1000PF K (TAPPING)	
C340	CMXM2A683J	C MYLAR	100V 0.068MF J TP		C636	CEXF1E470V	C ELECTRO	25V RSS 47MF (5X11) TP	
C341	CCXB1H102K	C CERA	50V B 1000PF K (TAPPING)		C641	CEXF1E101V	C ELECTRO	25V RSS 100MF (6.3X11) TP	
C350	CCXF1H223Z	C CERA	50V F 0.022MF Z (TAPPING)		C642	CEXF1E101V	C ELECTRO	25V RSS 100MF (6.3X11) TP	
C351	CCXF1H223Z	C CERA	50V F 0.022MF Z (TAPPING)		C660	CEXF1C100A	C ELECTRO	16V RSM 10MF 5X7	
C370	CCXF1H473Z	C CERA	50V F 0.047MF Z (TAPPING)		C661	CMXM2A224J	C MYLAR	100V 0.22MF J BULK	
C401	CEXF1H101V	C ELECTRO	50V RSS 100MF (8*11.5) TP		C662	CMXM2A224J	C MYLAR	100V 0.22MF J BULK	
C412	CEXF2C339V	C ELECTRO	160V RSS 3.3MF (8X16) TP		C665	CCXB1H472K	C CERA	50V B 4700PF K (TAPPING)	
C418	CCXB1H102K	C CERA	50V B 1000PF K (TAPPING)		C666	CBXF1H104Z	C CERA SEMI	50V F 0.1MF Z (TAPPING)	
C420	CCXB2H222K	C CERA	500V B 2200PF K (TAPPING)		C667	CCXB1H472K	C CERA	50V B 4700PF K (TAPPING)	
C424	CMXM2A333J	C MYLAR	100V 0.033MF J TP		C668	CMXM2A224J	C MYLAR	100V 0.22MF J BULK	
C502	CEXF1E101V	C ELECTRO	25V RSS 100MF (6.3X11) TP		C669	CMXM2A224J	C MYLAR	100V 0.22MF J BULK	
C504	CEXF1E470V	C ELECTRO	25V RSS 47MF (5X11) TP		C670	CEXF1H100V	C ELECTRO	50V RSS 10MF (5X11) TP	
C508	CEXF1H220V	C ELECTRO	50V RSS 22MF (5X11) TP		C690	CEXF1H479V	C ELECTRO	50V RSS 4.7MF (5*11) TP	
C510	CCXF1H473Z	C CERA	50V F 0.047MF Z (TAPPING)		C691	CEXF1H479V	C ELECTRO	50V RSS 4.7MF (5*11) TP	
C511	CEXF1H100V	C ELECTRO	50V RSS 10MF (5X11) TP		C770	CEXF1C101V	C ELECTRO	16V RSS 100MF (6.3X11) TP	
C519	CEXF1H109V	C ELECTRO	50V RSS 1MF (5X11) TP		C803	CCXF3A472Z	C CERA	1KV F 4700PF Z (T)	
C520	CEXF1H109V	C ELECTRO	50V RSS 1MF (5X11) TP		C804	CCXF3A472Z	C CERA	1KV F 4700PF Z (T)	
C521	CEXF1H109V	C ELECTRO	50V RSS 1MF (5X11) TP		C806	CEXF1H330V	C ELECTRO	50V RSS 33MF (6.3X11) TP	
C522	CEXF1H109V	C ELECTRO	50V RSS 1MF (5X11) TP		C807	CCXF1H473Z	C CERA	50V F 0.047MF Z (TAPPING)	
C525	CEXF1H220V	C ELECTRO	50V RSS 22MF (5X11) TP		C808	CEXF1H479V	C ELECTRO	50V RSS 4.7MF (5*11) TP	
C528	CCXF1H223Z	C CERA	50V F 0.022MF Z (TAPPING)		C809	CCXB1H102K	C CERA	50V B 1000PF K (TAPPING)	
C529	CCXF1H223Z	C CERA	50V F 0.022MF Z (TAPPING)		C821	CCXB1H102K	C CERA	50V B 1000PF K (TAPPING)	
C530	CCXF1H223Z	C CERA	50V F 0.022MF Z (TAPPING)		C824	CCXB3A471K	C CERA	1KV B 470PF K (T)	
C546	CEXF1H339V	C ELECTRO	50V RSS 3.3MF (5X11) TP		C831	CCXB3A471K	C CERA	1KV B 470PF K (T)	
C549	CEXF1H229V	C ELECTRO	50V RSS 2.2MF (5X11) TP		C835	CEXF1E470V	C ELECTRO	25V RSS 47MF (5X11) TP	
C553	CEXF1E101V	C ELECTRO	25V RSS 100MF (6.3X11) TP		C844	CEXF1E101V	C ELECTRO	25V RSS 100MF (6.3X11) TP	
C597	CEXF1H220V	C ELECTRO	50V RSS 22MF (5X11) TP		C850	CCXB1H821K	C CERA	50V B 820PF K (TAPPING)	
C602	CEXF1E221V	C ELECTRO	25V RSS 220MF (8X11.5) TP		C863	CEXF1E101V	C ELECTRO	25V RSS 100MF (6.3X11) TP	
C605	CEXF1E470V	C ELECTRO	25V RSS 47MF (5X11) TP		C888	CEXF1C470V	C ELECTRO	16V RSS 47MF (5X11) TP	
C608	CEXF1H100V	C ELECTRO	50V RSS 10MF (5X11) TP		C902	CMXL2E104K	C MYLAR	250V 0.1MF K MEU TP	
C610	CEXF1H100V	C ELECTRO	50V RSS 10MF (5X11) TP		F801A	4857415001	CLIP FUSE	PFC5000-0702	
C611	CEXF1H339V	C ELECTRO	50V RSS 3.3MF (5X11) TP		F801B	4857415001	CLIP FUSE	PFC5000-0702	
C612	CEXF1H109V	C ELECTRO	50V RSS 1MF (5X11) TP		L101	5CPX479K—	COIL PEAKING	4.7UH K RADIAL	
C613	CEXF1H109V	C ELECTRO	50V RSS 1MF (5X11) TP		Q103	T2SC5343Y-	TR	2SC5343Y	
C614	CEXF1H109V	C ELECTRO	50V RSS 1MF (5X11) TP		Q104	T2SC5343Y-	TR	2SC5343Y	
C615	CEXF1H109V	C ELECTRO	50V RSS 1MF (5X11) TP		Q120	T2SC5343Y-	TR	2SC5343Y	
C616	CEXF1H100V	C ELECTRO	50V RSS 10MF (5X11) TP		Q150	T2SC5343Y-	TR	2SC5343Y	
C617	CBXF1H104Z	C CERA SEMI	50V F 0.1MF Z (TAPPING)		Q151	T2SC5343Y-	TR	2SC5343Y	
C622	CXCH1H680J	C CERA	50V CH 68PF J (TAPPING)		Q333	T2SC5343Y-	TR	2SC5343Y	

Service Manual WP-895/895F, CP885/885F, CP485F

LOC	PART CODE	PART NAME	DESCRIPTION	REMARK	LOC	PART CODE	PART NAME	DESCRIPTION	REMARK
Q334	T2SC5343Y-	TR	2SC5343Y		C161	CZSL1H220J	C CERA	50V SL 22PF J (AXIAL)	
Q402	T2SD1207T-	TR	2SD1207-T (TAPPING)		C163	CCZF1H103Z	C CERA	50V F 0.01MF Z	
Q510	T2SC5343Y-	TR	2SC5343Y		C500	CCZF1H103Z	C CERA	50V F 0.01MF Z	
Q511	T2SC5343Y-	TR	2SC5343Y		C501	CCZF1H103Z	C CERA	50V F 0.01MF Z	
Q542	T2SA1980Y-	TR	2SA1980Y		C503	CBZF1H104Z	C CERA SEMI	50V F 0.1MF Z (AXIAL)	
Q543	T2SA1980Y-	TR	2SA1980Y		C505	CCZB1H102K	C CERA	50V B 1000PF K (AXIAL)	
Q544	T2SA1980Y-	TR	2SA1980Y		C506	CBZF1H104Z	C CERA SEMI	50V F 0.1MF Z (AXIAL)	
Q550	T2SC5343Y-	TR	2SC5343Y		C507	CCZF1H103Z	C CERA	50V F 0.01MF Z	
Q599	T2SA1980Y-	TR	2SA1980Y		C509	CCZF1H103Z	C CERA	50V F 0.01MF Z	
Q601	T2SA1980Y-	TR	2SA1980Y		C512	CCZF1H103Z	C CERA	50V F 0.01MF Z	
Q701	T2SC5343Y-	TR	2SC5343Y		C516	CCZB1H102K	C CERA	50V B 1000PF K (AXIAL)	
Q702	T2SA1980Y-	TR	2SA1980Y		C526	CBZF1H104Z	C CERA SEMI	50V F 0.1MF Z (AXIAL)	
Q807	T2SC5343Y-	TR	2SC5343Y		C527	CCZB1H102K	C CERA	50V B 1000PF K (AXIAL)	
Q808	T2SC5343Y-	TR	2SC5343Y		C534	CCZB1H333K	C CERA	50V B 0.033MF K (AXIAL)	
Q809	T2SC5343Y-	TR	2SC5343Y		C535	CCZB1H333K	C CERA	50V B 0.033MF K (AXIAL)	
Q810	T2SC5343Y-	TR	2SC5343Y		C536	CCZB1H333K	C CERA	50V B 0.033MF K (AXIAL)	
Q811	T2SC5343Y-	TR	2SC5343Y		C547	CBZF1H104Z	C CERA SEMI	50V F 0.1MF Z (AXIAL)	
Q850	T2SC5343Y-	TR	2SC5343Y		C548	CBZF1H104Z	C CERA SEMI	50V F 0.1MF Z (AXIAL)	
Q851	T2SC5343Y-	TR	2SC5343Y		C554	CBZF1H104Z	C CERA SEMI	50V F 0.1MF Z (AXIAL)	
QA1	T2SC5343Y-	TR	2SC5343Y		C560	CCZB1H101K	C CERA	50V B 100PF K (AXIAL)	
RB10	RV5426103P	R SEMI FIXED	RH0638C 10K OHM B		C561	CCZB1H101K	C CERA	50V B 100PF K (AXIAL)	
SW700	5S50101090	SW TACT	SKHV17910A		C568	CBZF1H104Z	C CERA SEMI	50V F 0.1MF Z (AXIAL)	
SW701	5S50101090	SW TACT	SKHV17910A		C571	CCZB1H101K	C CERA	50V B 100PF K (AXIAL)	
SW702	5S50101090	SW TACT	SKHV17910A		C578	CCZB1H221K	C CERA	50V B 220PF K (AXIAL)	
SW703	5S50101090	SW TACT	SKHV17910A		C579	CCZB1H221K	C CERA	50V B 220PF K (AXIAL)	
SW704	5S50101090	SW TACT	SKHV17910A		C581	CCZB1H101K	C CERA	50V B 100PF K (AXIAL)	
Z601	5PXF1B471M	FILTER EMI	CFI 06 B 1H 470PF		C585	CCZB1H101K	C CERA	50V B 100PF K (AXIAL)	
Z602	5PXF1B471M	FILTER EMI	CFI 06 B 1H 470PF		C589	CCZB1H221K	C CERA	50V B 220PF K (AXIAL)	
Z603	5PXF1B471M	FILTER EMI	CFI 06 B 1H 470PF		C590	CZCH1H309C	C CERA	50V CH 3PF C (AXIAL)	
Z604	5PXF1B471M	FILTER EMI	CFI 06 B 1H 470PF		C591	CZCH1H309C	C CERA	50V CH 3PF C (AXIAL)	
Z605	5PXF1B471M	FILTER EMI	CFI 06 B 1H 470PF		C601	CCZB1H472K	C CERA	50V B 4700PF K (AXIAL)	
Z606	5PXF1B471M	FILTER EMI	CFI 06 B 1H 470PF		C603	CCZB1H472K	C CERA	50V B 4700PF K (AXIAL)	
Z607	5PXF1B471M	FILTER EMI	CFI 06 B 1H 470PF		C620	CZCH1H309C	C CERA	50V CH 3PF C (AXIAL)	
Z608	5PXF1B471M	FILTER EMI	CFI 06 B 1H 470PF		C621	CZCH1H309C	C CERA	50V CH 3PF C (AXIAL)	
ZZ200	PTMPJAX28W5LF	PCB MAIN AXIAL AS	DWX-28W5ZLF		C631	CBZF1H104Z	C CERA SEMI	50V F 0.1MF Z (AXIAL)	
20	2TM10006LB	TAPE MASKING	3M #232-MAP-C 6.2X2000M		C650	CZSL1H680J	C CERA	50V SL 68PF J (AXIAL)	
10	2TM14006LB	TAPE MASKING	3M #232 6.0X2000M		C830	CBZF1H104Z	C CERA SEMI	50V F 0.1MF Z (AXIAL)	
A001	4859805093	PCB MAIN	WP-895		CA1	CCZB1H101K	C CERA	50V B 100PF K (AXIAL)	
C101	CCZB1H101K	C CERA	50V B 100PF K (AXIAL)		CA10	CCZB1H102K	C CERA	50V B 1000PF K (AXIAL)	
C103	CCZB1H102K	C CERA	50V B 1000PF K (AXIAL)		CA13	CCZB1H471K	C CERA	50V B 470PF K (AXIAL)	
C104	CCZB1H102K	C CERA	50V B 1000PF K (AXIAL)		CA14	CCZB1H471K	C CERA	50V B 470PF K (AXIAL)	
C116	CBZF1H104Z	C CERA SEMI	50V F 0.1MF Z (AXIAL)		CA15	CCZB1H471K	C CERA	50V B 470PF K (AXIAL)	
C119	CCZF1H103Z	C CERA	50V F 0.01MF Z		CA16	CCZB1H471K	C CERA	50V B 470PF K (AXIAL)	
C120	CCZB1H102K	C CERA	50V B 1000PF K (AXIAL)		CA17	CCZB1H471K	C CERA	50V B 470PF K (AXIAL)	
C151	CCZF1H103Z	C CERA	50V F 0.01MF Z		CA18	CCZB1H471K	C CERA	50V B 470PF K (AXIAL)	
C154	CCZF1H103Z	C CERA	50V F 0.01MF Z		CA19	CCZB1H222K	C CERA	50V B 2200PF K (AXIAL)	
C160	CCZF1H103Z	C CERA	50V F 0.01MF Z		CA2	CCZB1H101K	C CERA	50V B 100PF K (AXIAL)	

Service Manual WP-895/895F, CP885/885F, CP485F

LOC	PART CODE	PART NAME	DESCRIPTION	REMARK	LOC	PART CODE	PART NAME	DESCRIPTION	REMARK
CA20	CCZB1H222K	C CERA	50V B 2200PF K (AXIAL)		D840	D1N4148—	DIODE	1N4148 (TAPPING)	
CA3	CCZB1H101K	C CERA	50V B 100PF K (AXIAL)		D841	D1N4148—	DIODE	1N4148 (TAPPING)	
CA4	CCZB1H102K	C CERA	50V B 1000PF K (AXIAL)		D850	DUZ2R7B—	DIODE ZENER	UZ-2.7B	
CA7	CCZB1H471K	C CERA	50V B 470PF K (AXIAL)		D911	DBAV21—	DIODE	BAV21 (TAPPING)	
CA8	CCZB1H471K	C CERA	50V B 470PF K (AXIAL)		D912	DBAV21—	DIODE	BAV21 (TAPPING)	
D100	DUZ33B—	DIODE ZENER	UZ-33B		D913	DBAV21—	DIODE	BAV21 (TAPPING)	
D101	DBAT85—	DIODE	BAT85 (TAPPING)		D997	DBYT51J—	DIODE	BYT51J (TAPPING)	
D103	D1SS85TA—	DIODE	1SS85TA		DA10	DTZX5V6B—	DIODE ZENER	TX5V6B (TAPPING)	
D313	DBYW36—	DIODE	BYW36 (TAPPING)		DA11	DTZX5V6B—	DIODE ZENER	TX5V6B (TAPPING)	
D360	DTZX22C—	DIODE ZENER	TX22C (TAPPING)		DA15	DTZX5V6B—	DIODE ZENER	TX5V6B (TAPPING)	
D361	DUZ33B—	DIODE ZENER	UZ-33B		DA16	DTZX5V6B—	DIODE ZENER	TX5V6B (TAPPING)	
D362	DUZ33B—	DIODE ZENER	UZ-33B		DA20	DTZX5V6B—	DIODE ZENER	TX5V6B (TAPPING)	
D367	DUZ33B—	DIODE ZENER	UZ-33B		DA27	DTZX5V6B—	DIODE ZENER	TX5V6B (TAPPING)	
D405	DBYW36—	DIODE	BYW36 (TAPPING)		DA3	DTZX5V1B—	DIODE ZENER	TX5V1B (TAPPING)	
D407	DBYW36—	DIODE	BYW36 (TAPPING)		DA32	DTZX5V6B—	DIODE ZENER	TX5V6B (TAPPING)	
D408	DBYW36—	DIODE	BYW36 (TAPPING)		DA6	DTZX5V6B—	DIODE ZENER	TX5V6B (TAPPING)	
D410	D1N4004S—	DIODE	1N4004S		DA7	DTZX5V1B—	DIODE ZENER	TX5V1B (TAPPING)	
D411	D1N4004S—	DIODE	1N4004S		DA8	DTZX5V6B—	DIODE ZENER	TX5V6B (TAPPING)	
D450	DBYW36—	DIODE	BYW36 (TAPPING)		DA9	DTZX5V6B—	DIODE ZENER	TX5V6B (TAPPING)	
D520	D1N4148—	DIODE	1N4148 (TAPPING)		J003	85801065GY	WIRE COPPER	AWG22 1/0.65 TIN COATING	
D521	D1N4148—	DIODE	1N4148 (TAPPING)		J005	85801065GY	WIRE COPPER	AWG22 1/0.65 TIN COATING	
D533	D1N4148—	DIODE	1N4148 (TAPPING)		J006	85801065GY	WIRE COPPER	AWG22 1/0.65 TIN COATING	
D534	D1N4148—	DIODE	1N4148 (TAPPING)		J007	85801065GY	WIRE COPPER	AWG22 1/0.65 TIN COATING	
D537	D1N4148—	DIODE	1N4148 (TAPPING)		J008	85801065GY	WIRE COPPER	AWG22 1/0.65 TIN COATING	
D550	D1N4148—	DIODE	1N4148 (TAPPING)		J009	85801065GY	WIRE COPPER	AWG22 1/0.65 TIN COATING	
D551	D1N4148—	DIODE	1N4148 (TAPPING)		J013	85801065GY	WIRE COPPER	AWG22 1/0.65 TIN COATING	
D591	DUZ2R7B—	DIODE ZENER	UZ-2.7B		J015	85801065GY	WIRE COPPER	AWG22 1/0.65 TIN COATING	
D597	D1N4148—	DIODE	1N4148 (TAPPING)		J016	85801065GY	WIRE COPPER	AWG22 1/0.65 TIN COATING	
D598	D1N4148—	DIODE	1N4148 (TAPPING)		J018	85801065GY	WIRE COPPER	AWG22 1/0.65 TIN COATING	
D599	DTZX5V6B—	DIODE ZENER	TX5V6B (TAPPING)		J019	85801065GY	WIRE COPPER	AWG22 1/0.65 TIN COATING	
D601	D1N4148—	DIODE	1N4148 (TAPPING)		J022	85801065GY	WIRE COPPER	AWG22 1/0.65 TIN COATING	
D602	D1N4148—	DIODE	1N4148 (TAPPING)		J023	85801065GY	WIRE COPPER	AWG22 1/0.65 TIN COATING	
D603	D1N4148—	DIODE	1N4148 (TAPPING)		J024	85801065GY	WIRE COPPER	AWG22 1/0.65 TIN COATING	
D801	DBYT51J—	DIODE	BYT51J (TAPPING)		J025	85801065GY	WIRE COPPER	AWG22 1/0.65 TIN COATING	
D802	DBYT51J—	DIODE	BYT51J (TAPPING)		J036	85801065GY	WIRE COPPER	AWG22 1/0.65 TIN COATING	
D803	DBYT51J—	DIODE	BYT51J (TAPPING)		J037	85801065GY	WIRE COPPER	AWG22 1/0.65 TIN COATING	
D804	DBYT51J—	DIODE	BYT51J (TAPPING)		J038	85801065GY	WIRE COPPER	AWG22 1/0.65 TIN COATING	
D805	DBYW36—	DIODE	BYW36 (TAPPING)		J046	85801065GY	WIRE COPPER	AWG22 1/0.65 TIN COATING	
D806	DBYW36—	DIODE	BYW36 (TAPPING)		J047	85801065GY	WIRE COPPER	AWG22 1/0.65 TIN COATING	
D808	DBYW36—	DIODE	BYW36 (TAPPING)		J053	85801065GY	WIRE COPPER	AWG22 1/0.65 TIN COATING	
D809	DBYW36—	DIODE	BYW36 (TAPPING)		J054	85801065GY	WIRE COPPER	AWG22 1/0.65 TIN COATING	
D811	DTZX6V2—	DIODE ZENER	TX6V2B (TAPPING)		J056	85801065GY	WIRE COPPER	AWG22 1/0.65 TIN COATING	
D821	DBYW36—	DIODE	BYW36 (TAPPING)		J057	85801065GY	WIRE COPPER	AWG22 1/0.65 TIN COATING	
D824	D1N4148—	DIODE	1N4148 (TAPPING)		J058	85801065GY	WIRE COPPER	AWG22 1/0.65 TIN COATING	
D825	D1N4148—	DIODE	1N4148 (TAPPING)		J061	85801065GY	WIRE COPPER	AWG22 1/0.65 TIN COATING	
D830	DBYW36—	DIODE	BYW36 (TAPPING)		J065	85801065GY	WIRE COPPER	AWG22 1/0.65 TIN COATING	
D831	DBYW36—	DIODE	BYW36 (TAPPING)		J070	85801065GY	WIRE COPPER	AWG22 1/0.65 TIN COATING	

Service Manual WP-895/895F, CP885/885F, CP485F

LOC	PART CODE	PART NAME	DESCRIPTION	REMARK	LOC	PART CODE	PART NAME	DESCRIPTION	REMARK
J072	85801065GY	WIRE COPPER	AWG22 1/0.65 TIN COATING		J891	85801065GY	WIRE COPPER	AWG22 1/0.65 TIN COATING	
J073	85801065GY	WIRE COPPER	AWG22 1/0.65 TIN COATING		J896	85801065GY	WIRE COPPER	AWG22 1/0.65 TIN COATING	
J075	85801065GY	WIRE COPPER	AWG22 1/0.65 TIN COATING		J903	85801065GY	WIRE COPPER	AWG22 1/0.65 TIN COATING	
J076	85801065GY	WIRE COPPER	AWG22 1/0.65 TIN COATING		J909	85801065GY	WIRE COPPER	AWG22 1/0.65 TIN COATING	
J079	85801065GY	WIRE COPPER	AWG22 1/0.65 TIN COATING		J912	85801065GY	WIRE COPPER	AWG22 1/0.65 TIN COATING	
J080	85801065GY	WIRE COPPER	AWG22 1/0.65 TIN COATING		J914	85801065GY	WIRE COPPER	AWG22 1/0.65 TIN COATING	
J082	85801065GY	WIRE COPPER	AWG22 1/0.65 TIN COATING		J915	85801065GY	WIRE COPPER	AWG22 1/0.65 TIN COATING	
J088	85801065GY	WIRE COPPER	AWG22 1/0.65 TIN COATING		J916	85801065GY	WIRE COPPER	AWG22 1/0.65 TIN COATING	
J100	85801065GY	WIRE COPPER	AWG22 1/0.65 TIN COATING		J917	85801065GY	WIRE COPPER	AWG22 1/0.65 TIN COATING	
J101	85801065GY	WIRE COPPER	AWG22 1/0.65 TIN COATING		J918	85801065GY	WIRE COPPER	AWG22 1/0.65 TIN COATING	
J120	85801065GY	WIRE COPPER	AWG22 1/0.65 TIN COATING		J919	85801065GY	WIRE COPPER	AWG22 1/0.65 TIN COATING	
J123	85801065GY	WIRE COPPER	AWG22 1/0.65 TIN COATING		J920	85801065GY	WIRE COPPER	AWG22 1/0.65 TIN COATING	
J124	85801065GY	WIRE COPPER	AWG22 1/0.65 TIN COATING		L105	5CPZ479K02	COIL PEAKING	4.7UH 3.5MM K (LAL02TB)	
J153	85801065GY	WIRE COPPER	AWG22 1/0.65 TIN COATING		L153	5CPZ120K02	COIL PEAKING	12UH 3.5MM K (LAL02TB)	
J166	85801065GY	WIRE COPPER	AWG22 1/0.65 TIN COATING		L501	5CPZ479K02	COIL PEAKING	4.7UH 3.5MM K (LAL02TB)	
J201	85801065GY	WIRE COPPER	AWG22 1/0.65 TIN COATING		L502	5CPZ479K02	COIL PEAKING	4.7UH 3.5MM K (LAL02TB)	
J234	85801065GY	WIRE COPPER	AWG22 1/0.65 TIN COATING		L503	5CPZ479K02	COIL PEAKING	4.7UH 3.5MM K (LAL02TB)	
J826	85801065GY	WIRE COPPER	AWG22 1/0.65 TIN COATING		L504	5CPZ479K02	COIL PEAKING	4.7UH 3.5MM K (LAL02TB)	
J827	85801065GY	WIRE COPPER	AWG22 1/0.65 TIN COATING		L601	5CPZ479K02	COIL PEAKING	4.7UH 3.5MM K (LAL02TB)	
J828	85801065GY	WIRE COPPER	AWG22 1/0.65 TIN COATING		L602	5CPZ479K02	COIL PEAKING	4.7UH 3.5MM K (LAL02TB)	
J829	85801065GY	WIRE COPPER	AWG22 1/0.65 TIN COATING		L605	5CPZ479K02	COIL PEAKING	4.7UH 3.5MM K (LAL02TB)	
J833	85801065GY	WIRE COPPER	AWG22 1/0.65 TIN COATING		L650	5MC0000100	COIL BEAD	MD-5 (HC-3550)	
J835	85801065GY	WIRE COPPER	AWG22 1/0.65 TIN COATING		L801	5MC0000100	COIL BEAD	MD-5 (HC-3550)	
J836	85801065GY	WIRE COPPER	AWG22 1/0.65 TIN COATING		LA1	5CPZ100K04	COIL PEAKING	10UH 10.5MM K (LAL04TB)	
J840	85801065GY	WIRE COPPER	AWG22 1/0.65 TIN COATING		LA2	5CPZ100K04	COIL PEAKING	10UH 10.5MM K (LAL04TB)	
J841	85801065GY	WIRE COPPER	AWG22 1/0.65 TIN COATING		LA3	5CPZ100K04	COIL PEAKING	10UH 10.5MM K (LAL04TB)	
J844	85801065GY	WIRE COPPER	AWG22 1/0.65 TIN COATING		LA4	5CPZ100K04	COIL PEAKING	10UH 10.5MM K (LAL04TB)	
J845	85801065GY	WIRE COPPER	AWG22 1/0.65 TIN COATING		R101	RD-AZ222J	R CARBON FILM	1/6 2.2K OHM J	
J846	85801065GY	WIRE COPPER	AWG22 1/0.65 TIN COATING		R103	RD-AZ123J	R CARBON FILM	1/6 12K OHM J	
J853	85801065GY	WIRE COPPER	AWG22 1/0.65 TIN COATING		R104	RD-AZ104J	R CARBON FILM	1/6 100K OHM J	
J858	85801065GY	WIRE COPPER	AWG22 1/0.65 TIN COATING		R105	RD-AZ272J	R CARBON FILM	1/6 2.7K OHM J	
J859	85801065GY	WIRE COPPER	AWG22 1/0.65 TIN COATING		R106	RD-AZ561J	R CARBON FILM	1/6 560 OHM J	
J860	85801065GY	WIRE COPPER	AWG22 1/0.65 TIN COATING		R107	RD-AZ561J	R CARBON FILM	1/6 560 OHM J	
J865	85801065GY	WIRE COPPER	AWG22 1/0.65 TIN COATING		R110	RD-AZ682J	R CARBON FILM	1/6 6.8K OHM J	
J873	85801065GY	WIRE COPPER	AWG22 1/0.65 TIN COATING		R111	RD-AZ222J	R CARBON FILM	1/6 2.2K OHM J	
J874	85801065GY	WIRE COPPER	AWG22 1/0.65 TIN COATING		R116	RD-AZ682J	R CARBON FILM	1/6 6.8K OHM J	
J876	85801065GY	WIRE COPPER	AWG22 1/0.65 TIN COATING		R117	RD-AZ682J	R CARBON FILM	1/6 6.8K OHM J	
J878	85801065GY	WIRE COPPER	AWG22 1/0.65 TIN COATING		R118	RD-AZ151J	R CARBON FILM	1/6 150 OHM J	
J879	85801065GY	WIRE COPPER	AWG22 1/0.65 TIN COATING		R120	RD-AZ101J	R CARBON FILM	1/6 100 OHM J	
J880	85801065GY	WIRE COPPER	AWG22 1/0.65 TIN COATING		R131	RD-AZ472J	R CARBON FILM	1/6 4.7K OHM J	
J881	85801065GY	WIRE COPPER	AWG22 1/0.65 TIN COATING		R151	RD-AZ102J	R CARBON FILM	1/6 1K OHM J	
J882	85801065GY	WIRE COPPER	AWG22 1/0.65 TIN COATING		R152	RD-AZ271J	R CARBON FILM	1/6 270 OHM J	
J883	85801065GY	WIRE COPPER	AWG22 1/0.65 TIN COATING		R153	RD-AZ470J	R CARBON FILM	1/6 47 OHM J	
J885	85801065GY	WIRE COPPER	AWG22 1/0.65 TIN COATING		R154	RD-AZ470J	R CARBON FILM	1/6 47 OHM J	
J887	85801065GY	WIRE COPPER	AWG22 1/0.65 TIN COATING		R155	RD-AZ751J	R CARBON FILM	1/6 750 OHM J	
J888	85801065GY	WIRE COPPER	AWG22 1/0.65 TIN COATING		R160	RD-AZ472J	R CARBON FILM	1/6 4.7K OHM J	
J889	85801065GY	WIRE COPPER	AWG22 1/0.65 TIN COATING		R161	RD-AZ102J	R CARBON FILM	1/6 1K OHM J	

Service Manual WP-895/895F, CP885/885F, CP485F

LOC	PART CODE	PART NAME	DESCRIPTION	REMARK	LOC	PART CODE	PART NAME	DESCRIPTION	REMARK
R162	RD-AZ153J	R CARBON FILM	1/6 15K OHM J		R540	RD-AZ101J	R CARBON FILM	1/6 100 OHM J	
R163	RD-AZ752J	R CARBON FILM	1/6 7.5K OHM J		R541	RD-AZ122J	R CARBON FILM	1/6 1.2K OHM J	
R164	RD-AZ752J	R CARBON FILM	1/6 7.5K OHM J		R542	RD-AZ223J	R CARBON FILM	1/6 22K OHM J	
R177	RD-AZ562J	R CARBON FILM	1/6 5.6K OHM J		R543	RD-AZ271J	R CARBON FILM	1/6 270 OHM J	
R190	RD-AZ221J	R CARBON FILM	1/6 220 OHM J		R544	RD-AZ222J	R CARBON FILM	1/6 2.2K OHM J	
R191	RD-AZ331J	R CARBON FILM	1/6 330 OHM J		R548	RD-AZ103J	R CARBON FILM	1/6 10K OHM J	
R301	RD-4Z472J	R CARBON FILM	1/4 4.7K OHM J		R550	RD-AZ102J	R CARBON FILM	1/6 1K OHM J	
R310	RD-AZ392J	R CARBON FILM	1/6 3.9K OHM J		R555	RD-AZ102J	R CARBON FILM	1/6 1K OHM J	
R311	RD-AZ392J	R CARBON FILM	1/6 3.9K OHM J		R560	RD-AZ101J	R CARBON FILM	1/6 100 OHM J	
R330	RD-4Z473J	R CARBON FILM	1/4 47K OHM J		R561	RD-AZ101J	R CARBON FILM	1/6 100 OHM J	
R331	RD-2Z201J	R CARBON FILM	1/2 200 OHM J		R562	RD-AZ152J	R CARBON FILM	1/6 1.5K OHM J	
R333	RD-AZ222J	R CARBON FILM	1/6 2.2K OHM J		R563	RD-AZ152J	R CARBON FILM	1/6 1.5K OHM J	
R334	RD-AZ222J	R CARBON FILM	1/6 2.2K OHM J		R566	RD-AZ220J	R CARBON FILM	1/6 22 OHM J	
R340	RD-4Z334J	R CARBON FILM	1/4 330K OHM J		R568	RD-AZ102J	R CARBON FILM	1/6 1K OHM J	
R341	RD-4Z333J	R CARBON FILM	1/4 33K OHM J		R569	RD-AZ181J	R CARBON FILM	1/6 180 OHM J	
R350	RD-4Z272J	R CARBON FILM	1/4 2.7K OHM J		R570	RD-AZ271J	R CARBON FILM	1/6 270 OHM J	
R351	RD-4Z272J	R CARBON FILM	1/4 2.7K OHM J		R572	RD-AZ101J	R CARBON FILM	1/6 100 OHM J	
R370	RD-4Z159J	R CARBON FILM	1/4 1.5 OHM J		R573	RD-AZ101J	R CARBON FILM	1/6 100 OHM J	
R394	RD-AZ272J	R CARBON FILM	1/6 2.7K OHM J		R576	RD-AZ181J	R CARBON FILM	1/6 180 OHM J	
R395	RD-4Z394J	R CARBON FILM	1/4 390K OHM J		R577	RD-AZ181J	R CARBON FILM	1/6 180 OHM J	
R396	RD-AZ272J	R CARBON FILM	1/6 2.7K OHM J		R578	RD-AZ330J	R CARBON FILM	1/6 33 OHM J	
R397	RD-AZ104J	R CARBON FILM	1/6 100K OHM J		R579	RD-AZ330J	R CARBON FILM	1/6 33 OHM J	
R401	RD-4Z272J	R CARBON FILM	1/4 2.7K OHM J		R580	RD-AZ271J	R CARBON FILM	1/6 270 OHM J	
R402	RD-4Z220J	R CARBON FILM	1/4 22 OHM J		R582	RD-AZ101J	R CARBON FILM	1/6 100 OHM J	
R404	RD-2Z399J	R CARBON FILM	1/2 3.9 OHM J		R583	RD-AZ101J	R CARBON FILM	1/6 100 OHM J	
R406	RD-2Z821J	R CARBON FILM	1/2 820 OHM J		R586	RD-AZ271J	R CARBON FILM	1/6 270 OHM J	
R420	RD-4Z682J	R CARBON FILM	1/4 6.8K OHM J		R587	RD-AZ101J	R CARBON FILM	1/6 100 OHM J	
R490	RD-4Z101J	R CARBON FILM	1/4 100 OHM J		R588	RD-AZ101J	R CARBON FILM	1/6 100 OHM J	
R500	RD-AZ101J	R CARBON FILM	1/6 100 OHM J		R589	RD-AZ330J	R CARBON FILM	1/6 33 OHM J	
R501	RD-AZ101J	R CARBON FILM	1/6 100 OHM J		R591	RD-AZ431J	R CARBON FILM	1/6 430 OHM J	
R502	RD-AZ101J	R CARBON FILM	1/6 100 OHM J		R592	RD-AZ102J	R CARBON FILM	1/6 1K OHM J	
R503	RD-AZ101J	R CARBON FILM	1/6 100 OHM J		R593	RD-AZ104J	R CARBON FILM	1/6 100K OHM J	
R504	RD-AZ473J	R CARBON FILM	1/6 47K OHM J		R594	RD-AZ222J	R CARBON FILM	1/6 2.2K OHM J	
R506	RD-AZ223J	R CARBON FILM	1/6 22K OHM J		R595	RD-AZ682J	R CARBON FILM	1/6 6.8K OHM J	
R507	RD-AZ562J	R CARBON FILM	1/6 5.6K OHM J		R596	RD-AZ472J	R CARBON FILM	1/6 4.7K OHM J	
R508	RD-AZ562J	R CARBON FILM	1/6 5.6K OHM J		R597	RD-AZ153J	R CARBON FILM	1/6 15K OHM J	
R509	RD-AZ472J	R CARBON FILM	1/6 4.7K OHM J		R598	RD-AZ153J	R CARBON FILM	1/6 15K OHM J	
R511	RD-AZ133J	R CARBON FILM	1/6 13K OHM J		R599	RD-AZ101J	R CARBON FILM	1/6 100 OHM J	
R512	RD-AZ133J	R CARBON FILM	1/6 13K OHM J		R601	RD-AZ101J	R CARBON FILM	1/6 100 OHM J	
R513	85801065GY	WIRE COPPER	AWG22 1/0.65 TIN COATING		R602	RD-AZ104J	R CARBON FILM	1/6 100K OHM J	
R517	RD-AZ102J	R CARBON FILM	1/6 1K OHM J		R605	RD-AZ101J	R CARBON FILM	1/6 100 OHM J	
R518	RD-AZ102J	R CARBON FILM	1/6 1K OHM J		R606	RD-AZ101J	R CARBON FILM	1/6 100 OHM J	
R530	RD-AZ103J	R CARBON FILM	1/6 10K OHM J		R608	RD-2Z151J	R CARBON FILM	1/2 150 OHM J	
R532	RD-AZ223J	R CARBON FILM	1/6 22K OHM J		R609	RD-2Z151J	R CARBON FILM	1/2 150 OHM J	
R533	RD-AZ103J	R CARBON FILM	1/6 10K OHM J		R614	RD-AZ102J	R CARBON FILM	1/6 1K OHM J	
R535	RD-AZ201J	R CARBON FILM	1/6 200 OHM J		R615	RD-AZ102J	R CARBON FILM	1/6 1K OHM J	
R537	RD-AZ201J	R CARBON FILM	1/6 200 OHM J		R620	RD-AZ102J	R CARBON FILM	1/6 1K OHM J	

Service Manual WP-895/895F, CP885/885F, CP485F

LOC	PART CODE	PART NAME	DESCRIPTION	REMARK	LOC	PART CODE	PART NAME	DESCRIPTION	REMARK
R621	RD-AZ102J-	R CARBON FILM	1/6 1K OHM J		R913	RD-AZ101J-	R CARBON FILM	1/6 100 OHM J	
R622	RD-AZ102J-	R CARBON FILM	1/6 1K OHM J		R921	RC-2Z102K-	R CARBON COMP	1/2 1K OHM K	
R641	RD-AZ102J-	R CARBON FILM	1/6 1K OHM J		R922	RC-2Z102K-	R CARBON COMP	1/2 1K OHM K	
R642	RD-AZ102J-	R CARBON FILM	1/6 1K OHM J		R923	RC-2Z102K-	R CARBON COMP	1/2 1K OHM K	
R646	RD-AZ102J-	R CARBON FILM	1/6 1K OHM J		R983	RD-4Z472J-	R CARBON FILM	1/4 4.7K OHM J	
R647	RD-AZ102J-	R CARBON FILM	1/6 1K OHM J		R996	RD-2Z105J-	R CARBON FILM	1/2 1M OHM J	
R649	RD-AZ102J-	R CARBON FILM	1/6 1K OHM J		R997	RD-2Z102J-	R CARBON FILM	1/2 1K OHM J	
R650	RD-AZ752J-	R CARBON FILM	1/6 7.5K OHM J		RA1	RD-AZ220J-	R CARBON FILM	1/6 22 OHM J	
R651	RD-AZ102J-	R CARBON FILM	1/6 1K OHM J		RA10	RD-AZ101J-	R CARBON FILM	1/6 100 OHM J	
R652	RD-AZ102J-	R CARBON FILM	1/6 1K OHM J		RA11	RD-AZ750J-	R CARBON FILM	1/6 75 OHM J	
R660	RD-AZ752J-	R CARBON FILM	1/6 7.5K OHM J		RA12	RD-AZ750J-	R CARBON FILM	1/6 75 OHM J	
R661	RD-AZ123J-	R CARBON FILM	1/6 12K OHM J		RA13	RD-AZ113J-	R CARBON FILM	1/6 11K OHM J	
R662	RD-AZ123J-	R CARBON FILM	1/6 12K OHM J		RA14	RD-AZ750J-	R CARBON FILM	1/6 75 OHM J	
R700	RD-2Z332J-	R CARBON FILM	1/2 3.3K OHM J		RA16	RD-AZ750J-	R CARBON FILM	1/6 75 OHM J	
R709	RD-AZ102J-	R CARBON FILM	1/6 1K OHM J		RA19	RD-AZ750J-	R CARBON FILM	1/6 75 OHM J	
R710	RD-AZ102J-	R CARBON FILM	1/6 1K OHM J		RA2	RD-AZ101J-	R CARBON FILM	1/6 100 OHM J	
R711	RD-AZ103J-	R CARBON FILM	1/6 10K OHM J		RA29	RD-AZ102J-	R CARBON FILM	1/6 1K OHM J	
R712	RD-AZ181J-	R CARBON FILM	1/6 180 OHM J		RA3	RD-AZ101J-	R CARBON FILM	1/6 100 OHM J	
R713	RD-AZ331J-	R CARBON FILM	1/6 330 OHM J		RA32	RD-AZ680J-	R CARBON FILM	1/6 68 OHM J	
R720	RD-AZ122J-	R CARBON FILM	1/6 1.2K OHM J		RA4	RD-AZ101J-	R CARBON FILM	1/6 100 OHM J	
R721	RD-AZ181J-	R CARBON FILM	1/6 180 OHM J		RA44	RD-AZ113J-	R CARBON FILM	1/6 11K OHM J	
R722	RD-AZ221J-	R CARBON FILM	1/6 220 OHM J		RA5	RD-AZ333J-	R CARBON FILM	1/6 33K OHM J	
R723	RD-AZ331J-	R CARBON FILM	1/6 330 OHM J		RA6	RD-AZ750J-	R CARBON FILM	1/6 75 OHM J	
R724	RD-AZ471J-	R CARBON FILM	1/6 470 OHM J		RA7	RD-AZ333J-	R CARBON FILM	1/6 33K OHM J	
R805	RD-2Z100J-	R CARBON FILM	1/2 10 OHM J		RA8	RD-AZ750J-	R CARBON FILM	1/6 75 OHM J	
R806	RD-2Z472J-	R CARBON FILM	1/2 4.7K OHM J		RA9	RD-AZ750J-	R CARBON FILM	1/6 75 OHM J	
R807	RD-2Z272J-	R CARBON FILM	1/2 2.7K OHM J		RA90	RD-AZ220J-	R CARBON FILM	1/6 22 OHM J	
R808	RD-2Z821J-	R CARBON FILM	1/2 820 OHM J		RA91	RD-AZ473J-	R CARBON FILM	1/6 47K OHM J	
R810	RD-4Z102J-	R CARBON FILM	1/4 1K OHM J		RA92	RD-AZ223J-	R CARBON FILM	1/6 22K OHM J	
R811	RC-2Z565KP	R CARBON COMP	1/2 5.6M OHM K	△					
R817	RD-AZ473J-	R CARBON FILM	1/6 47K OHM J						
R820	RD-AZ102J-	R CARBON FILM	1/6 1K OHM J						
R821	RD-4Z102J-	R CARBON FILM	1/4 1K OHM J						
R823	RD-2Z472J-	R CARBON FILM	1/2 4.7K OHM J						
R829	RD-AZ103J-	R CARBON FILM	1/6 10K OHM J						
R830	RD-AZ332J-	R CARBON FILM	1/6 3.3K OHM J						
R841	RD-2Z470J-	R CARBON FILM	1/2 47 OHM J						
R851	RD-AZ391J-	R CARBON FILM	1/6 390 OHM J						
R852	RD-AZ102J-	R CARBON FILM	1/6 1K OHM J						
R855	RD-4Z335J-	R CARBON FILM	1/4 3.3M OHM J						
R870	RD-2Z222J-	R CARBON FILM	1/2 2.2K OHM J						
R901	RD-AZ221J-	R CARBON FILM	1/6 220 OHM J						
R902	RD-AZ221J-	R CARBON FILM	1/6 220 OHM J						
R903	RD-AZ221J-	R CARBON FILM	1/6 220 OHM J						
R910	RD-AZ101J-	R CARBON FILM	1/6 100 OHM J						
R911	RD-AZ101J-	R CARBON FILM	1/6 100 OHM J						
R912	RD-AZ101J-	R CARBON FILM	1/6 100 OHM J						

6. Service Parts List (TW28D11)

CAUTION

“△” Parts recommended for stock.

“⊗” Safety critical componen, Replace only with genuine Daewoo safety parts.

LOC	PART CODE	PART NAME	DESCRIPTION	REMARK
10000	PTACPW-SWX	ACCESSORY AS	DWX-_____	
11000	48586A1617	INSTRUC. MANUAL	ALL	
12000	48B4846G22	REMOTE CONTROL	R-46G22	⊗
13000	4850Q00910	BATTERY	"AAA 1.5V (SUPERGARD-PTL)"	
14000	4858214400F	POLY BAG	MIN 350MM BOBINE	
20000	PTPKCP28W8	PACKING AS	28W8	
21000	4858058900	CARTONBOX	28W5/28W8/W9	
22000	4858197300UP	PAD UP	28W8/28W9	
23000	4858197300DN	PAD DOWN	28W8/28W9	
24000	4858216202F-02	POLY BAG 25"-28"	PE COEXTRUDE 1650X1270	
25000	485580B001F	STICKER	115 X 285	
26000	4850075990F2	TAPE CLOSING	TAPE (75 X 990M) 3739	
27000	4850075066F3	TAPE CLOSING	TAPE (75 X 66M) 3739	
30000	PTFMSJ28W9	FRONT MASK AS	28W9 M.SILVER	
31100	4855617401	MARK BRAND	AL SILVER (28B1)	
32000	48548628-050792	BUTTON POWER	28W9 M.SILVER	
32100	4856716000	SPRING	SWPA PIE0.5	
34000	4855060500	DECO CTRL	28W9 PVC T0.25(LPP)	
35000	48519470AS	DOOR AS	28W9 DOOR + DECO SENSOR	
35100	4857923300	DOOR LOCK	"LA701 (KIFCO),MODEL WITH DOOR"	
36500	7172401212	SCREW TAPPTITE	T12 TRS 4X12 MFZN BK	
37500	7172401212	SCREW TAPPTITE	T12 TRS 4X12 MFZN BK	
31000	PTFMSJ28W9F	FRONT MASK FINI	28W9 M.SILVER	
00010	48520818-33	FRONT MASK	28W9 M.SILVER	
00020	485SV128BP	PAINT	L8341307	
40000	PTCRT-28WF-VI	CRT AS	28" 16/9 FLAT 50HZ	△
41000	4859635860	CRT 28" WIDE FLAT	W66E JY011X101	⊗ △
41100	4850706057	CONN AS	"ODY-2019 (14"-20"-21"-25"-28")	
42000	4851902110	CRT GROUND AS	28" 16/9	
43000	58C000159	DEGAUSSING COIL	DC-28FW2 (WP-895F DWF)	△
44000	4856215402	WASHER RUBBER	CR T=2MM	
450DN	4856015820	SCREW CRT FIX	SWRM-SK5 L=35	
450UP	4856015820	SCREW CRT FIX	SWRM-SK5 L=35	
50000	PTSPSUBM27	SPEAKER AS	CP-776	
51000	4858311110	SPEAKER	"12W 8 OHM SP-58126F 25" 28" X2"	⊗
51100	4850704530	CONN AS	YH025-03+35098-ULW=700	
52000	4858311110	SPEAKER	"12W 8 OHM SP-58126F 25" 28" X2"	⊗
60000	PTMPMSWF81P	PCBAS	DWF-28_ZZP-SUM	
62000	4859906310	POWER CORD AS	14-LO-H03VWH2+HOU=2200 UK	
63000	4856818300	CLAMP WIRE	PH-WL-5034	
64000	4856812001	TIE CABLE	"NYLON66 DAT100,14,20,21,25,28"	
61000	PTMPMSWF80PW	PCB WITH TUNER	DWF-28_ZZP	
61100	PSMPMSWF80PW	PCB W/O TUNER	DWF-28_ZZP	
61200	4859722430	TUNER VARACTOR	UV1316/AIG-3	
61300	2193011101	SOLDER WIRE	"RS 60-1.2 1.6A PROD,APF,ROULX"	
70000	PTBCSH28W5	BACK COVER AS	28W5	
71000	48521589-22	BACK COVER	28W5	
73000	7172401612	SCREW TAPPTITE	T12 TRS 4X16MFZN BK	
75000	4855415800	SPEC PLATE	"150 ART P/E FILM TVCR.HIT"	
ZZ290	PTMPMSF28W8ZP	PCB MAIN MANUAL AS	DWF-28W8ZP	
10	2193100801	SOLDER BAR	SN-PB-63:37 3P(NO FLUX)	
40	2291050314	FLUX SOLVENT	IM-1000	
20	2193011101	SOLDER WIRE	RS 60-1.2 1.6A	
30	2291050617P	FLUX SOLDER	CF-329D	
50	2291140501	WAX COVER	60G/PC	
60	2291051001	FLUX KILLER	KFT-7	
C106	CEXF1H221V	C ELECTRO	50V RSS 220MF (10X16) TP	
C118	CMXL1J474J	C MYLAR	63V 0.47MF MKT	
C315	CEXF2A470V	C ELECTRO	100V RSS 47MF (10X16) TP	
C402	CMYH3C133J	C MYLAR	1.6KV 0.013MF J	
C408	CMYE2G514J	C MYLAR	400V 0.51MF J (PL)	
C409	CMYE2G394J	C MYLAR	400V PU 0.39MF J	
C415	CEXF2E479V	C ELECTRO	250V RSS 4.7MF (10X16)TP	
C430	CCXB3D681K	C CERA	2KV B 680PF K (TAPPING)	
C431	CMXM2A103J	C MYLAR	100V 0.01MF J (TP)	
C440	CMXE2G273J	C MYLAR	400V PU 0.027MF J (T)	
C499	CEYD1H689W	C ELECTRO	50V RHD 6.8MF (16X35.5)	
C604	CEXF1E102V	C ELECTRO	25V RSS 1000MF (13X20) TP	
C801	CLTJB3474K	C LINE ACROSS	AC250V 0.47MF UIC/SNDF/SV	△

LOC	PART CODE	PART NAME	DESCRIPTION	REMARK
C805	CEYN2G181P	C ELECTRO	400V LHS 180MF (25X35)	
C811	CCYR3D681K	C CERA	2KV R 680PF K 125C	
C812	CHTAF E472M	C CERA AC	4KV 4700PF M KX DE1610	△
C813	CEXF2E101V	C ELECTRO	250V RSS 100MF (18X35.5)	
C814	CEYF2E470V	C ELECTRO	250V RSS 47MF (16X25)	
C820	CCYR3A471K	C CERA	1KV 470PF K 125C	
C823	CEXF1E102V	C ELECTRO	25V RSS 1000MF (13X20) TP	
C832	CEXF1E102V	C ELECTRO	25V RSS 1000MF (13X20) TP	
C840	CEXF1C222V	C ELECTRO	16V RSS 2200MF (13X25)TP	
C841	CEXF1C332V	C ELECTRO	16V RSS 3300MF	
C861	CEXF1E102C	C ELECTRO	25V RUS 1000MF 13X20 TP	
C866	CCYR3A471K	C CERA	1KV 470PF K 125C	
C900	CCXB3D102K	C CERA	2KV B 1000 PF K (TAPPING)	
C910	CEXF2E479V	C ELECTRO	250V RSS 4.7MF (10X16)TP	
C997	CEXF2E100V	C ELECTRO	250V RSS 10MF (10X20) TP	
D403	DBY228----	DIODE	BY228	
D404	DBYW76----	DIODE	BYW76	
D820	DBYW76----	DIODE	BYW76	
D860	DBYW76----	DIODE	BYW76	
F801	5FSCB4022R	FUSE CERA	SEMKO F4AH 4A 250V MF51	△
G900	4SG0D00103	SPARK GAP	S-23 900V-1.5KV	
I101	1TDA4470M-	IC IF	TDA4470-M	⊗
I301	1TDA8358J-	IC VERTICAL	TDA8358J	⊗
I301A	4857028227	HEAT SINK	AL EX ANODIZING	
I301B	7174301011	SCREW TAPPTITE	T12 RND 3X10 MFZN	
I501	1DW3834AE1	IC MICOM	DW3834A-AE1	⊗
I601	1MSP3410G-	IC SOUND PROCESSOR	MSP3410G	⊗
I602	1TDA8946J-	IC AUDIO	TDA8946J	
I602A	4857028215	HEAT SINK	AL EX NO ANODOZING	
I602B	7174301011	SCREW TAPPTITE	T12 RND 3X10 MFZN	
I702	1AT24C16PC	IC MEMORY	AT24C16-10PC	⊗
I703	1TSOP1238W	IC PREAMP	TSOP1238W1	⊗
I801	1STRF6654-	IC SMPS	STRF-6654	⊗
I801A	4857027701	HEAT SINK	AL EX	
I801B	7174300811	SCREW TAPPTITE	T12 RND 3X8 MFZN	
I804	1KP1010C-	IC PHOTO COUPLER	KP-1010C	△
I806	1SE130N---	IC	SE130N	⊗
I810	1X0202DA--	THYRISTOR	X0202DA	⊗
I820	1KA7805---	IC REGULATOR	KA7805	
I822	1KA7808---	IC REGULATOR	KA7808	
I823	1KA7805---	IC REGULATOR	KA7805	
I901	1TDA6107Q-	IC VIDEO	TDA6107Q	⊗
I901A	4857031100	HEAT SINK	A1050P-H24 T2.0	
I901B	7174300811	SCREW TAPPTITE	T12 RND 3X8 MFZN	
JP01	4859102130	JACK EARPHONE	YSC-1537	
JPA1	4859200401	SOCKET RGB	SR-21A1 (ANGLE TYPE)	
JPA2	4859200401	SOCKET RGB	SR-21A1 (ANGLE TYPE)	
JPA3	4859108450	JACK PIN BOARD	YSC03P-4120-14A	
JPA4	4859106740	SVHS JACK	PH-SJ-9505A	
L150	58E0000041	COIL AFT	TRF-A005	⊗
L380	58C0000120	COIL CHOKE	CH-100Q	
L381	58C0000120	COIL CHOKE	CH-100Q	
L802	58C9430599	COIL CHOKE	AZ-9004Y(94MH)	
LF801	5PLF24A1-	FILTER LINE	LF-24A1	△
M351	4858900002	HOLDER LED AS	LH-3P	
P401	4850706N08	CONNECTOR	6PIN 500MM BOARD IN TYPE	
P402	4859240120	CONN WAFER	YFV500-06	
P501	4850705N14	CONNECTOR	BIC-05T-25T+ULW=500	
P601	4859231720	CONN WAFER	YW025-04	
P801	4859287320	CONN WAFER	MKS2822 (LOMAX NEW TYPE)	
P802	4859242220	CONN WAFER	YFV800-02	
P903	4859238620	CONN WAFER	YFV500-02	
Q401	12SD1880-	TR	2SD1880	
Q401A	4857024500	HEAT SINK	AL EX	
Q401B	7174300811	SCREW TAPPTITE	T12 RND 3X8 MFZN	
R398	RF01Y828JA	R FUSIBLE	1W 0.82 OHM J A	
R399	RS02Y569JS	R M-OXIDE FILM	2W 5.6 OHM J SMALL	
R415	RS02Y102JS	R M-OXIDE FILM	2W 1K OHM J SMALL	
R450	RS02Y223JS	R M-OXIDE FILM	2W 22K OHM J SMALL	
R801	DPC7R0M290	POSITOR	96709 (PHILIPS)	
R802	RS02Y753JS	R M-OXIDE FILM	2W 75K OHM J SMALL	

Service Manual WP-895/895F, CP885/885F, CP485F

LOC	PART CODE	PART NAME	DESCRIPTION	REMARK
R803	RS02Y473JS	R M-OXIDE FILM	2W 47K OHM J SMALL	
R804	RF02Y228K-	R FUSIBLE	2W 0.22 OHM K	
R819	RX10T339J-	R CEMENT	10W 3.3 OHM J TRIPOD	
R850	RS02Y229JS	R M-OXIDE FILM	2W 2.2 OHM J SMALL	
R906	RF01Y109JA	R FUSIBLE	1W 1 OHM J A CURVE	
SC11	4859303530	SOCKET CRT	PCS629-03C	
SF1	5PK3953M--	FILTER SAW	K3953M	⊕
SF2	5PK9650M--	FILTER SAW	K9650M	⊕
SW801	5540101143	SW PUSH	PS3-22SP (P.C.B)	
T401	50D19A1--	TRANS DRIVE	TD-19A1	⚠
T402	13625018--	FBT	1362.5018	⚠
T801	50M4936B2-	TRANS SMPS	2094.0057B	⚠
U100	4859722430	TUNER VARACTOR	UV1316AIG-3	⊕
X501	5XE20R250E	CRYSTAL QUARTZ	HC-49U 20.2500MHZ 30PPM	
X601	5XE18R432E	CRYSTAL QUARTZ	HC-49U 18.43200MHZ 30PPM	
Z153	5PYX15R5MB	FILTER CERA	X15.5MB	
Z2200	PTMPJBF28W8ZP	PCB MAIN EYE LET AS	DWF-28W8ZP	
E001	4856310600	EYE LET	BSR 2.3(R2.3)	
E002	4856310600	EYE LET	BSR 2.3(R2.3)	
E003	4856310600	EYE LET	BSR 2.3(R2.3)	
E004	4856310600	EYE LET	BSR 2.3(R2.3)	
E005	4856310300	EYE LET	BSR T0.2 (R1.6)	
E006	4856310300	EYE LET	BSR T0.2 (R1.6)	
E007	4856310300	EYE LET	BSR T0.2 (R1.6)	
E008	4856310300	EYE LET	BSR T0.2 (R1.6)	
E011	4856310300	EYE LET	BSR T0.2 (R1.6)	
E012	4856310600	EYE LET	BSR 2.3(R2.3)	
E013	4856310600	EYE LET	BSR 2.3(R2.3)	
E014	4856310600	EYE LET	BSR 2.3(R2.3)	
E015	4856310600	EYE LET	BSR 2.3(R2.3)	
E016	4856310600	EYE LET	BSR 2.3(R2.3)	
E017	4856310600	EYE LET	BSR 2.3(R2.3)	
E018	4856310300	EYE LET	BSR T0.2 (R1.6)	
E021	4856310600	EYE LET	BSR 2.3(R2.3)	
E022	4856310600	EYE LET	BSR 2.3(R2.3)	
E023	4856310300	EYE LET	BSR T0.2 (R1.6)	
E024	4856310300	EYE LET	BSR T0.2 (R1.6)	
E025	4856310600	EYE LET	BSR 2.3(R2.3)	
E026	4856310600	EYE LET	BSR 2.3(R2.3)	
E027	4856310600	EYE LET	BSR 2.3(R2.3)	
E028	4856310600	EYE LET	BSR 2.3(R2.3)	
E029	4856310600	EYE LET	BSR 2.3(R2.3)	
E030	4856310600	EYE LET	BSR 2.3(R2.3)	
E031	4856310300	EYE LET	BSR T0.2 (R1.6)	
E034	4856310300	EYE LET	BSR T0.2 (R1.6)	
E035	4856310300	EYE LET	BSR T0.2 (R1.6)	
E038	4856310600	EYE LET	BSR 2.3(R2.3)	
E1	4856310300	EYE LET	BSR T0.2 (R1.6)	
E2	4856310300	EYE LET	BSR T0.2 (R1.6)	
E3	4856310300	EYE LET	BSR T0.2 (R1.6)	
E36	4856310600	EYE LET	BSR 2.3(R2.3)	
E37	4856310600	EYE LET	BSR 2.3(R2.3)	
E4	4856310300	EYE LET	BSR T0.2 (R1.6)	
E5	4856310300	EYE LET	BSR T0.2 (R1.6)	
Z2200	PTMPJRF28W8ZP	PCB MAIN RADIAL AS	DWF-28W8ZP	
C102	CXFE1E470V	C ELECTRO	25V RSS 47MF (5X11) TP	
C110	CXCH1H150J	C CERA	50V CH 15PF J (TAPPING)	
C117	CXFX1H229V	C ELECTRO	50V RSS 2.2MF (5X11) TP	
C121	CXFE1H100V	C ELECTRO	50V RSS 10MF (5X11) TP	
C122	CXFE1E100V	C ELECTRO	25V RSS 10MF TP	
C152	CXFE1E100V	C ELECTRO	25V RSS 10MF TP	
C153	CXFX1H229V	C ELECTRO	50V RSS 2.2MF (5X11) TP	
C156	CBXF1H104Z	C CERA SEMI	50V F 0.1MF Z (TAPPING)	
C157	CXFE1E100V	C ELECTRO	25V RSS 10MF TP	
C158	CBXF1H104Z	C CERA SEMI	50V F 0.1MF Z (TAPPING)	
C164	CXFE1E470V	C ELECTRO	25V RSS 47MF (5X11) TP	
C301	CMXM2A224J	C MYLAR	100V 0.22MF J BULK	
C305	CXFE1E221V	C ELECTRO	25V RSS 220MF (8X11.5) TP	
C313	CMXM2A104J	C MYLAR	100V 0.1MF J TP	
C320	CBXF1H104Z	C CERA SEMI	50V F 0.1MF Z (TAPPING)	
C340	CMXM2A683J	C MYLAR	100V 0.068MF J TP	
C341	CCXB1H102K	C CERA	50V B 1000PF K (TAPPING)	
C350	CCXF1H223Z	C CERA	50V F 0.022MF Z (TAPPING)	
C351	CCXF1H223Z	C CERA	50V F 0.022MF Z (TAPPING)	
C370	CCXF1H473Z	C CERA	50V F 0.047MF Z (TAPPING)	
C401	CXFE1H101V	C ELECTRO	50V RSS 100MF (6.3X11) TP	
C412	CXFE2C339V	C ELECTRO	160V RSS 3.3MF (8X16) TP	
C418	CCXB1H102K	C CERA	50V B 1000PF K (TAPPING)	
C420	CCXB2H222K	C CERA	500V B 2200PF K (TAPPING)	
C424	CMXM2A333J	C MYLAR	100V 0.033MF J TP	
C502	CXFE1E101V	C ELECTRO	25V RSS 100MF (6.3X11) TP	
C504	CXFE1E470V	C ELECTRO	25V RSS 47MF (5X11) TP	

LOC	PART CODE	PART NAME	DESCRIPTION	REMARK
C508	CXFX1H220V	C ELECTRO	50V RSS 22MF (5X11) TP	
C510	CCXF1H473Z	C CERA	50V F 0.047MF Z (TAPPING)	
C511	CXFE1E100V	C ELECTRO	25V RSS 10MF TP	
C519	CXFX1H109V	C ELECTRO	50V RSS 1MF (6X11) TP	
C520	CXFX1H109V	C ELECTRO	50V RSS 1MF (6X11) TP	
C521	CXFX1H109V	C ELECTRO	50V RSS 1MF (6X11) TP	
C522	CXFX1H109V	C ELECTRO	50V RSS 1MF (6X11) TP	
C525	CXFX1H220V	C ELECTRO	50V RSS 22MF (5X11) TP	
C528	CCXF1H223Z	C CERA	50V F 0.022MF Z (TAPPING)	
C529	CCXF1H223Z	C CERA	50V F 0.022MF Z (TAPPING)	
C530	CCXF1H223Z	C CERA	50V F 0.022MF Z (TAPPING)	
C546	CXFX1H339V	C ELECTRO	50V RSS 3.3MF (5X11) TP	
C547	CBXF1H104Z	C CERA SEMI	50V F 0.1MF Z (TAPPING)	
C549	CXFX1H229V	C ELECTRO	50V RSS 2.2MF (5X11) TP	
C553	CXFE1E101V	C ELECTRO	25V RSS 100MF (6.3X11) TP	
C597	CXFX1H220V	C ELECTRO	50V RSS 22MF (5X11) TP	
C602	CXFE1E221V	C ELECTRO	25V RSS 220MF (8X11.5) TP	
C605	CXFE1E470V	C ELECTRO	25V RSS 47MF (5X11) TP	
C608	CXFE1E100V	C ELECTRO	25V RSS 10MF TP	
C610	CXFE1E100V	C ELECTRO	25V RSS 10MF TP	
C611	CXFX1H339V	C ELECTRO	50V RSS 3.3MF (5X11) TP	
C612	CXFX1H109V	C ELECTRO	50V RSS 1MF (6X11) TP	
C613	CXFX1H109V	C ELECTRO	50V RSS 1MF (6X11) TP	
C614	CXFX1H109V	C ELECTRO	50V RSS 1MF (6X11) TP	
C615	CXFX1H109V	C ELECTRO	50V RSS 1MF (6X11) TP	
C616	CXFE1E100V	C ELECTRO	25V RSS 10MF TP	
C617	CBXF1H104Z	C CERA SEMI	50V F 0.1MF Z (TAPPING)	
C622	CXCH1H680J	C CERA	50V CH 68PF J (TAPPING)	
C623	CXFX1H109V	C ELECTRO	50V RSS 1MF (6X11) TP	
C624	CXFX1H109V	C ELECTRO	50V RSS 1MF (6X11) TP	
C625	CXFE1E101V	C ELECTRO	25V RSS 100MF (6.3X11) TP	
C626	CXFE1E101V	C ELECTRO	25V RSS 100MF (6.3X11) TP	
C629	CBXF1H104Z	C CERA SEMI	50V F 0.1MF Z (TAPPING)	
C630	CXFE1E470V	C ELECTRO	25V RSS 47MF (5X11) TP	
C634	CXFE1E100V	C ELECTRO	25V RSS 10MF TP	
C635	CCXB1H102K	C CERA	50V B 1000PF K (TAPPING)	
C636	CXFE1E470V	C ELECTRO	25V RSS 47MF (5X11) TP	
C641	CXFE1E101V	C ELECTRO	25V RSS 100MF (6.3X11) TP	
C642	CXFE1E101V	C ELECTRO	25V RSS 100MF (6.3X11) TP	
C660	CXFC1C100A	C ELECTRO	16V RSS 10MF 5X7	
C661	CMXM2A224J	C MYLAR	100V 0.22MF J BULK	
C662	CMXM2A224J	C MYLAR	100V 0.22MF J BULK	
C665	CCXB1H472K	C CERA	50V B 4700PF K (TAPPING)	
C666	CBXF1H104Z	C CERA SEMI	50V F 0.1MF Z (TAPPING)	
C667	CCXB1H472K	C CERA	50V B 4700PF K (TAPPING)	
C668	CMXM2A224J	C MYLAR	100V 0.22MF J BULK	
C669	CMXM2A224J	C MYLAR	100V 0.22MF J BULK	
C690	CXFX1H479V	C ELECTRO	50V RSS 4.7MF (5*11) TP	
C691	CXFX1H479V	C ELECTRO	50V RSS 4.7MF (5*11) TP	
C770	CXFC1C101V	C ELECTRO	16V RSS 100MF (6.3X11) TP	
C803	CCXF3A472Z	C CERA	1KV F 4700PF Z (T)	
C804	CCXF3A472Z	C CERA	1KV F 4700PF Z (T)	
C806	CXFX1H330V	C ELECTRO	50V RSS 33MF (6.3X11) TP	
C807	CCXF1H473Z	C CERA	50V F 0.047MF Z (TAPPING)	
C808	CXFX1H479V	C ELECTRO	50V RSS 4.7MF (5*11) TP	
C809	CCXB1H102K	C CERA	50V B 1000PF K (TAPPING)	
C821	CCXB1H102K	C CERA	50V B 1000PF K (TAPPING)	
C824	CCXB3A471K	C CERA	1KV B 4700PF K (T)	
C831	CCXB3A471K	C CERA	1KV B 4700PF K (T)	
C835	CXFE1E470V	C ELECTRO	25V RSS 47MF (5X11) TP	
C844	CXFE1E101V	C ELECTRO	25V RSS 100MF (6.3X11) TP	
C850	CCXB1H821K	C CERA	50V B 820PF K (TAPPING)	
C863	CXFE1E101V	C ELECTRO	25V RSS 100MF (6.3X11) TP	
C888	CXFC1C470V	C ELECTRO	16V RSS 47MF (5X11) TP	
C902	CMXL2E104K	C MYLAR	250V 0.1MF K MEU TP	
F801A	4857415001	CLIP FUSE	PF-C5000-0702	
F801B	4857415001	CLIP FUSE	PF-C5000-0702	
L101	5CPX479K--	COIL PEAKING	4.7UH K RADIAL	
Q103	12SC5343Y-	TR	2SC5343Y	
Q104	12SC5343Y-	TR	2SC5343Y	
Q120	12SC5343Y-	TR	2SC5343Y	
Q150	12SC5343Y-	TR	2SC5343Y	
Q151	12SC5343Y-	TR	2SC5343Y	
Q333	12SC5343Y-	TR	2SC5343Y	
Q334	12SC5343Y-	TR	2SC5343Y	
Q402	12SD1207I-	TR	2SD1207-T (TAPPING)	
Q510	12SC5343Y-	TR	2SC5343Y	
Q511	12SC5343Y-	TR	2SC5343Y	
Q542	12SA1980Y-	TR	2SA1980Y	
Q543	12SA1980Y-	TR	2SA1980Y	
Q544	12SA1980Y-	TR	2SA1980Y	
Q550	12SC5343Y-	TR	2SC5343Y	

Service Manual WP-895/895F, CP885/885F, CP485F

LOC	PART CODE	PART NAME	DESCRIPTION	REMARK
O599	T2SA1980Y-	TR	2SA1980Y	
O601	T2SA1980Y-	TR	2SA1980Y	
O701	T2SC5343Y-	TR	2SC5343Y	
O702	T2SA1980Y-	TR	2SA1980Y	
O807	T2SC5343Y-	TR	2SC5343Y	
O808	T2SC5343Y-	TR	2SC5343Y	
O809	T2SC5343Y-	TR	2SC5343Y	
O810	T2SC5343Y-	TR	2SC5343Y	
O811	T2SC5343Y-	TR	2SC5343Y	
O850	T2SC5343Y-	TR	2SC5343Y	
O851	T2SC5343Y-	TR	2SC5343Y	
QA1	T2SC5343Y-	TR	2SC5343Y	
RB10	RV5426103P	R SEMI FIXED	RH0638C 10K OHM B	
SW700	5S50101090	SW TACT	SKHV17910A	
SW701	5S50101090	SW TACT	SKHV17910A	
SW702	5S50101090	SW TACT	SKHV17910A	
SW703	5S50101090	SW TACT	SKHV17910A	
SW704	5S50101090	SW TACT	SKHV17910A	
Z601	5PXF1B471M	FILTER EMI	CFI 06 B 1H 470PF	
Z602	5PXF1B471M	FILTER EMI	CFI 06 B 1H 470PF	
Z603	5PXF1B471M	FILTER EMI	CFI 06 B 1H 470PF	
Z604	5PXF1B471M	FILTER EMI	CFI 06 B 1H 470PF	
Z605	5PXF1B471M	FILTER EMI	CFI 06 B 1H 470PF	
Z606	5PXF1B471M	FILTER EMI	CFI 06 B 1H 470PF	
Z607	5PXF1B471M	FILTER EMI	CFI 06 B 1H 470PF	
Z608	5PXF1B471M	FILTER EMI	CFI 06 B 1H 470PF	
ZZ200	P1MPJAF-28W8ZP	PCB MAIN AXIAL AS	DWF-28W8ZP	
20	21M1006LB	TAPE MASKING	3M #232-MAP-C 6.2X2000M	
10	21M14006LB	TAPE MASKING	3M #232 6.0X2000M	
A001	4859805193	PCB MAIN	WP-895F	
C101	CCZB1H101K	C CERA	50V B 100PF K (AXIAL)	
C103	CCZB1H102K	C CERA	50V B 1000PF K (AXIAL)	
C104	CCZB1H102K	C CERA	50V B 1000PF K (AXIAL)	
C116	CBZF1H104Z	C CERA SEMI	50V F 0.1MF Z (AXIAL)	
C119	CCZF1H103Z	C CERA	50V F 0.01MF Z	
C120	CCZB1H102K	C CERA	50V B 1000PF K (AXIAL)	
C151	CCZF1H103Z	C CERA	50V F 0.01MF Z	
C154	CCZF1H103Z	C CERA	50V F 0.01MF Z	
C160	CCZF1H103Z	C CERA	50V F 0.01MF Z	
C161	CZSL1H220J	C CERA	50V SL 22PF J (AXIAL)	
C163	CCZF1H103Z	C CERA	50V F 0.01MF Z	
C500	CCZF1H103Z	C CERA	50V F 0.01MF Z	
C501	CCZF1H103Z	C CERA	50V F 0.01MF Z	
C503	CBZF1H104Z	C CERA SEMI	50V F 0.1MF Z (AXIAL)	
C505	CCZB1H102K	C CERA	50V B 1000PF K (AXIAL)	
C506	CBZF1H104Z	C CERA SEMI	50V F 0.1MF Z (AXIAL)	
C507	CCZF1H103Z	C CERA	50V F 0.01MF Z	
C509	CCZF1H103Z	C CERA	50V F 0.01MF Z	
C512	CCZF1H103Z	C CERA	50V F 0.01MF Z	
C516	CCZB1H102K	C CERA	50V B 1000PF K (AXIAL)	
C526	CBZF1H104Z	C CERA SEMI	50V F 0.1MF Z (AXIAL)	
C527	CCZB1H102K	C CERA	50V B 1000PF K (AXIAL)	
C534	CCZB1H333K	C CERA	50V B 0.033MF K (AXIAL)	
C535	CCZB1H333K	C CERA	50V B 0.033MF K (AXIAL)	
C536	CCZB1H333K	C CERA	50V B 0.033MF K (AXIAL)	
C548	CBZF1H104Z	C CERA SEMI	50V F 0.1MF Z (AXIAL)	
C554	CBZF1H104Z	C CERA SEMI	50V F 0.1MF Z (AXIAL)	
C560	CCZB1H101K	C CERA	50V B 100PF K (AXIAL)	
C561	CCZB1H101K	C CERA	50V B 100PF K (AXIAL)	
C568	CBZF1H104Z	C CERA SEMI	50V F 0.1MF Z (AXIAL)	
C571	CCZB1H101K	C CERA	50V B 100PF K (AXIAL)	
C578	CCZB1H221K	C CERA	50V B 220PF K (AXIAL)	
C579	CCZB1H221K	C CERA	50V B 220PF K (AXIAL)	
C581	CCZB1H101K	C CERA	50V B 100PF K (AXIAL)	
C585	CCZB1H101K	C CERA	50V B 100PF K (AXIAL)	
C589	CCZB1H221K	C CERA	50V B 220PF K (AXIAL)	
C590	CZCH1H309C	C CERA	50V CH 3PF C (AXIAL)	
C591	CZCH1H309C	C CERA	50V CH 3PF C (AXIAL)	
C601	CCZB1H472K	C CERA	50V B 4700PF K (AXIAL)	
C603	CCZB1H472K	C CERA	50V B 4700PF K (AXIAL)	
C620	CZCH1H309C	C CERA	50V CH 3PF C (AXIAL)	
C621	CZCH1H309C	C CERA	50V CH 3PF C (AXIAL)	
C631	CBZF1H104Z	C CERA SEMI	50V F 0.1MF Z (AXIAL)	
C650	CZSL1H680J	C CERA	50V SL 68PF J (AXIAL)	
C830	CBZF1H104Z	C CERA SEMI	50V F 0.1MF Z (AXIAL)	
CA1	CCZB1H101K	C CERA	50V B 100PF K (AXIAL)	
CA10	CCZB1H102K	C CERA	50V B 1000PF K (AXIAL)	
CA13	CCZB1H471K	C CERA	50V B 470PF K (AXIAL)	
CA14	CCZB1H471K	C CERA	50V B 470PF K (AXIAL)	
CA15	CCZB1H471K	C CERA	50V B 470PF K (AXIAL)	
CA16	CCZB1H471K	C CERA	50V B 470PF K (AXIAL)	
CA17	CCZB1H471K	C CERA	50V B 470PF K (AXIAL)	

LOC	PART CODE	PART NAME	DESCRIPTION	REMARK
CA18	CCZB1H471K	C CERA	50V B 470PF K (AXIAL)	
CA19	CCZB1H222K	C CERA	50V B 2200PF K (AXIAL)	
CA2	CCZB1H101K	C CERA	50V B 100PF K (AXIAL)	
CA20	CCZB1H222K	C CERA	50V B 2200PF K (AXIAL)	
CA3	CCZB1H101K	C CERA	50V B 100PF K (AXIAL)	
CA4	CCZB1H102K	C CERA	50V B 1000PF K (AXIAL)	
CA7	CCZB1H471K	C CERA	50V B 470PF K (AXIAL)	
CA8	CCZB1H471K	C CERA	50V B 470PF K (AXIAL)	
D100	DUZ33B----	DIODE ZENER	UZ-33B	
D101	DBAT85----	DIODE	BAT85 (TAPPING)	
D103	D1SS85TA--	DIODE	1SS85TA	
D313	DBYW36----	DIODE	BYW36 (TAPPING)	
D360	DTZX22C---	DIODE ZENER	1ZX22C (TAPPING)	
D361	DUZ33B----	DIODE ZENER	UZ-33B	
D362	DUZ33B----	DIODE ZENER	UZ-33B	
D367	DUZ33B----	DIODE ZENER	UZ-33B	
D405	DBYW36----	DIODE	BYW36 (TAPPING)	
D407	DBYW36----	DIODE	BYW36 (TAPPING)	
D408	DBYW36----	DIODE	BYW36 (TAPPING)	
D410	D1N4004S--	DIODE	1N4004S	
D411	D1N4004S--	DIODE	1N4004S	
D450	DBYW36----	DIODE	BYW36 (TAPPING)	
D520	D1N4148---	DIODE	1N4148 (TAPPING)	
D521	D1N4148---	DIODE	1N4148 (TAPPING)	
D533	D1N4148---	DIODE	1N4148 (TAPPING)	
D534	D1N4148---	DIODE	1N4148 (TAPPING)	
D537	D1N4148---	DIODE	1N4148 (TAPPING)	
D550	D1N4148---	DIODE	1N4148 (TAPPING)	
D551	D1N4148---	DIODE	1N4148 (TAPPING)	
D591	DUZ2R7B---	DIODE ZENER	UZ-2.7B	
D597	D1N4148---	DIODE	1N4148 (TAPPING)	
D598	D1N4148---	DIODE	1N4148 (TAPPING)	
D599	DTZX5V6B--	DIODE ZENER	1ZX5V6B (TAPPING)	
D601	D1N4148---	DIODE	1N4148 (TAPPING)	
D602	D1N4148---	DIODE	1N4148 (TAPPING)	
D603	85801065GY	WIRE COPPER	AWG22 1/0.65 TIN COATING	
D801	DBY151J---	DIODE	BY151J (TAPPING)	
D802	DBY151J---	DIODE	BY151J (TAPPING)	
D803	DBY151J---	DIODE	BY151J (TAPPING)	
D804	DBY151J---	DIODE	BY151J (TAPPING)	
D805	DBYW36----	DIODE	BYW36 (TAPPING)	
D806	DBYW36----	DIODE	BYW36 (TAPPING)	
D808	DBYW36----	DIODE	BYW36 (TAPPING)	
D809	DBYW36----	DIODE	BYW36 (TAPPING)	
D811	DTZX6V2B--	DIODE ZENER	1ZX6V2B (TAPPING)	
D821	DBYW36----	DIODE	BYW36 (TAPPING)	
D824	D1N4148---	DIODE	1N4148 (TAPPING)	
D825	D1N4148---	DIODE	1N4148 (TAPPING)	
D830	DBYW36----	DIODE	BYW36 (TAPPING)	
D831	DBYW36----	DIODE	BYW36 (TAPPING)	
D840	D1N4148---	DIODE	1N4148 (TAPPING)	
D841	D1N4148---	DIODE	1N4148 (TAPPING)	
D850	DUZ2R7B---	DIODE ZENER	UZ-2.7B	
D911	DBAV21----	DIODE	BAV21 (TAPPING)	
D912	DBAV21----	DIODE	BAV21 (TAPPING)	
D913	DBAV21----	DIODE	BAV21 (TAPPING)	
D997	DBY151J---	DIODE	BY151J (TAPPING)	
DA10	DTZX5V6B--	DIODE ZENER	1ZX5V6B (TAPPING)	
DA11	DTZX5V6B--	DIODE ZENER	1ZX5V6B (TAPPING)	
DA15	DTZX5V6B--	DIODE ZENER	1ZX5V6B (TAPPING)	
DA16	DTZX5V6B--	DIODE ZENER	1ZX5V6B (TAPPING)	
DA20	DTZX5V6B--	DIODE ZENER	1ZX5V6B (TAPPING)	
DA27	DTZX5V6B--	DIODE ZENER	1ZX5V6B (TAPPING)	
DA3	DTZX5V1B--	DIODE ZENER	1ZX5V1B (TAPPING)	
DA32	DTZX5V6B--	DIODE ZENER	1ZX5V6B (TAPPING)	
DA6	DTZX5V6B--	DIODE ZENER	1ZX5V6B (TAPPING)	
DA7	DTZX5V1B--	DIODE ZENER	1ZX5V1B (TAPPING)	
DA8	DTZX5V6B--	DIODE ZENER	1ZX5V6B (TAPPING)	
DA9	DTZX5V6B--	DIODE ZENER	1ZX5V6B (TAPPING)	
J001	85801065GY	WIRE COPPER	AWG22 1/0.65 TIN COATING	
J002	85801065GY	WIRE COPPER	AWG22 1/0.65 TIN COATING	
J003	85801065GY	WIRE COPPER	AWG22 1/0.65 TIN COATING	
J005	85801065GY	WIRE COPPER	AWG22 1/0.65 TIN COATING	
J006	85801065GY	WIRE COPPER	AWG22 1/0.65 TIN COATING	
J007	85801065GY	WIRE COPPER	AWG22 1/0.65 TIN COATING	
J008	85801065GY	WIRE COPPER	AWG22 1/0.65 TIN COATING	
J009	85801065GY	WIRE COPPER	AWG22 1/0.65 TIN COATING	
J015	85801065GY	WIRE COPPER	AWG22 1/0.65 TIN COATING	
J016	85801065GY	WIRE COPPER	AWG22 1/0.65 TIN COATING	
J018	85801065GY	WIRE COPPER	AWG22 1/0.65 TIN COATING	
J019	85801065GY	WIRE COPPER	AWG22 1/0.65 TIN COATING	
J022	85801065GY	WIRE COPPER	AWG22 1/0.65 TIN COATING	

Service Manual WP-895/895F, CP885/885F, CP485F

LOC	PART CODE	PART NAME	DESCRIPTION	REMARK
J023	85801065GY	WIRE COPPER	AWG22 1/0.65 TIN COATING	
J024	85801065GY	WIRE COPPER	AWG22 1/0.65 TIN COATING	
J025	85801065GY	WIRE COPPER	AWG22 1/0.65 TIN COATING	
J036	85801065GY	WIRE COPPER	AWG22 1/0.65 TIN COATING	
J038	85801065GY	WIRE COPPER	AWG22 1/0.65 TIN COATING	
J046	85801065GY	WIRE COPPER	AWG22 1/0.65 TIN COATING	
J047	85801065GY	WIRE COPPER	AWG22 1/0.65 TIN COATING	
J053	85801065GY	WIRE COPPER	AWG22 1/0.65 TIN COATING	
J054	85801065GY	WIRE COPPER	AWG22 1/0.65 TIN COATING	
J056	85801065GY	WIRE COPPER	AWG22 1/0.65 TIN COATING	
J057	85801065GY	WIRE COPPER	AWG22 1/0.65 TIN COATING	
J058	85801065GY	WIRE COPPER	AWG22 1/0.65 TIN COATING	
J061	85801065GY	WIRE COPPER	AWG22 1/0.65 TIN COATING	
J065	85801065GY	WIRE COPPER	AWG22 1/0.65 TIN COATING	
J070	85801065GY	WIRE COPPER	AWG22 1/0.65 TIN COATING	
J072	85801065GY	WIRE COPPER	AWG22 1/0.65 TIN COATING	
J073	85801065GY	WIRE COPPER	AWG22 1/0.65 TIN COATING	
J075	85801065GY	WIRE COPPER	AWG22 1/0.65 TIN COATING	
J076	85801065GY	WIRE COPPER	AWG22 1/0.65 TIN COATING	
J079	85801065GY	WIRE COPPER	AWG22 1/0.65 TIN COATING	
J080	85801065GY	WIRE COPPER	AWG22 1/0.65 TIN COATING	
J082	85801065GY	WIRE COPPER	AWG22 1/0.65 TIN COATING	
J088	85801065GY	WIRE COPPER	AWG22 1/0.65 TIN COATING	
J100	85801065GY	WIRE COPPER	AWG22 1/0.65 TIN COATING	
J101	85801065GY	WIRE COPPER	AWG22 1/0.65 TIN COATING	
J120	85801065GY	WIRE COPPER	AWG22 1/0.65 TIN COATING	
J123	85801065GY	WIRE COPPER	AWG22 1/0.65 TIN COATING	
J124	85801065GY	WIRE COPPER	AWG22 1/0.65 TIN COATING	
J153	85801065GY	WIRE COPPER	AWG22 1/0.65 TIN COATING	
J166	85801065GY	WIRE COPPER	AWG22 1/0.65 TIN COATING	
J234	85801065GY	WIRE COPPER	AWG22 1/0.65 TIN COATING	
J801	85801065GY	WIRE COPPER	AWG22 1/0.65 TIN COATING	
J802	85801065GY	WIRE COPPER	AWG22 1/0.65 TIN COATING	
J803	85801065GY	WIRE COPPER	AWG22 1/0.65 TIN COATING	
J826	85801065GY	WIRE COPPER	AWG22 1/0.65 TIN COATING	
J827	85801065GY	WIRE COPPER	AWG22 1/0.65 TIN COATING	
J828	85801065GY	WIRE COPPER	AWG22 1/0.65 TIN COATING	
J829	85801065GY	WIRE COPPER	AWG22 1/0.65 TIN COATING	
J833	85801065GY	WIRE COPPER	AWG22 1/0.65 TIN COATING	
J835	85801065GY	WIRE COPPER	AWG22 1/0.65 TIN COATING	
J836	85801065GY	WIRE COPPER	AWG22 1/0.65 TIN COATING	
J840	85801065GY	WIRE COPPER	AWG22 1/0.65 TIN COATING	
J841	85801065GY	WIRE COPPER	AWG22 1/0.65 TIN COATING	
J844	85801065GY	WIRE COPPER	AWG22 1/0.65 TIN COATING	
J845	85801065GY	WIRE COPPER	AWG22 1/0.65 TIN COATING	
J846	85801065GY	WIRE COPPER	AWG22 1/0.65 TIN COATING	
J853	85801065GY	WIRE COPPER	AWG22 1/0.65 TIN COATING	
J858	85801065GY	WIRE COPPER	AWG22 1/0.65 TIN COATING	
J859	85801065GY	WIRE COPPER	AWG22 1/0.65 TIN COATING	
J860	85801065GY	WIRE COPPER	AWG22 1/0.65 TIN COATING	
J865	85801065GY	WIRE COPPER	AWG22 1/0.65 TIN COATING	
J873	85801065GY	WIRE COPPER	AWG22 1/0.65 TIN COATING	
J874	85801065GY	WIRE COPPER	AWG22 1/0.65 TIN COATING	
J876	85801065GY	WIRE COPPER	AWG22 1/0.65 TIN COATING	
J878	85801065GY	WIRE COPPER	AWG22 1/0.65 TIN COATING	
J879	85801065GY	WIRE COPPER	AWG22 1/0.65 TIN COATING	
J880	85801065GY	WIRE COPPER	AWG22 1/0.65 TIN COATING	
J881	85801065GY	WIRE COPPER	AWG22 1/0.65 TIN COATING	
J883	85801065GY	WIRE COPPER	AWG22 1/0.65 TIN COATING	
J885	85801065GY	WIRE COPPER	AWG22 1/0.65 TIN COATING	
J887	85801065GY	WIRE COPPER	AWG22 1/0.65 TIN COATING	
J888	85801065GY	WIRE COPPER	AWG22 1/0.65 TIN COATING	
J889	85801065GY	WIRE COPPER	AWG22 1/0.65 TIN COATING	
J891	85801065GY	WIRE COPPER	AWG22 1/0.65 TIN COATING	
J896	85801065GY	WIRE COPPER	AWG22 1/0.65 TIN COATING	
J903	85801065GY	WIRE COPPER	AWG22 1/0.65 TIN COATING	
J909	85801065GY	WIRE COPPER	AWG22 1/0.65 TIN COATING	
J912	85801065GY	WIRE COPPER	AWG22 1/0.65 TIN COATING	
J914	85801065GY	WIRE COPPER	AWG22 1/0.65 TIN COATING	
J915	85801065GY	WIRE COPPER	AWG22 1/0.65 TIN COATING	
J916	85801065GY	WIRE COPPER	AWG22 1/0.65 TIN COATING	
J917	85801065GY	WIRE COPPER	AWG22 1/0.65 TIN COATING	
J918	85801065GY	WIRE COPPER	AWG22 1/0.65 TIN COATING	
J919	85801065GY	WIRE COPPER	AWG22 1/0.65 TIN COATING	
J920	85801065GY	WIRE COPPER	AWG22 1/0.65 TIN COATING	
J921	85801065GY	WIRE COPPER	AWG22 1/0.65 TIN COATING	
J924	85801065GY	WIRE COPPER	AWG22 1/0.65 TIN COATING	
J925	85801065GY	WIRE COPPER	AWG22 1/0.65 TIN COATING	
J926	85801065GY	WIRE COPPER	AWG22 1/0.65 TIN COATING	
L105	5CPZ479K02	COIL PEAKING	4.7UH 3.5MM K (LAL02TB)	
L153	5CPZ120K02	COIL PEAKING	12UH 3.5MM K (LAL02TB)	
L501	5CPZ479K02	COIL PEAKING	4.7UH 3.5MM K (LAL02TB)	

LOC	PART CODE	PART NAME	DESCRIPTION	REMARK
L502	5CPZ479K02	COIL PEAKING	4.7UH 3.5MM K (LAL02TB)	
L503	5CPZ479K02	COIL PEAKING	4.7UH 3.5MM K (LAL02TB)	
L504	5CPZ479K02	COIL PEAKING	4.7UH 3.5MM K (LAL02TB)	
L601	5CPZ479K02	COIL PEAKING	4.7UH 3.5MM K (LAL02TB)	
L602	5CPZ479K02	COIL PEAKING	4.7UH 3.5MM K (LAL02TB)	
L605	5CPZ479K02	COIL PEAKING	4.7UH 3.5MM K (LAL02TB)	
L650	5MC0000100	COIL BEAD	MD-5 (HC-3550)	
L801	5MC0000100	COIL BEAD	MD-5 (HC-3550)	
LA1	5CPZ100K04	COIL PEAKING	10UH 10.5MM K (LAL04TB)	
LA2	5CPZ100K04	COIL PEAKING	10UH 10.5MM K (LAL04TB)	
LA3	5CPZ100K04	COIL PEAKING	10UH 10.5MM K (LAL04TB)	
LA4	5CPZ100K04	COIL PEAKING	10UH 10.5MM K (LAL04TB)	
R101	RD-AZ222J	R CARBON FILM	1/6 2.2K OHM J	
R103	RD-AZ123J	R CARBON FILM	1/6 12K OHM J	
R104	RD-AZ104J	R CARBON FILM	1/6 100K OHM J	
R105	RD-AZ272J	R CARBON FILM	1/6 2.7K OHM J	
R106	RD-AZ561J	R CARBON FILM	1/6 560 OHM J	
R107	RD-AZ561J	R CARBON FILM	1/6 560 OHM J	
R110	RD-AZ682J	R CARBON FILM	1/6 6.8K OHM J	
R111	RD-AZ222J	R CARBON FILM	1/6 2.2K OHM J	
R116	RD-AZ682J	R CARBON FILM	1/6 6.8K OHM J	
R117	RD-AZ682J	R CARBON FILM	1/6 6.8K OHM J	
R118	RD-AZ151J	R CARBON FILM	1/6 150 OHM J	
R120	RD-AZ101J	R CARBON FILM	1/6 100 OHM J	
R131	RD-AZ472J	R CARBON FILM	1/6 4.7K OHM J	
R151	RD-AZ102J	R CARBON FILM	1/6 1K OHM J	
R152	RD-AZ271J	R CARBON FILM	1/6 270 OHM J	
R153	RD-AZ470J	R CARBON FILM	1/6 4.7 OHM J	
R154	RD-AZ470J	R CARBON FILM	1/6 4.7 OHM J	
R155	RD-AZ751J	R CARBON FILM	1/6 750 OHM J	
R160	RD-AZ472J	R CARBON FILM	1/6 4.7K OHM J	
R161	RD-AZ102J	R CARBON FILM	1/6 1K OHM J	
R162	RD-AZ153J	R CARBON FILM	1/6 15K OHM J	
R163	RD-AZ752J	R CARBON FILM	1/6 7.5K OHM J	
R164	RD-AZ752J	R CARBON FILM	1/6 7.5K OHM J	
R177	RD-AZ562J	R CARBON FILM	1/6 5.6K OHM J	
R190	RD-AZ221J	R CARBON FILM	1/6 220 OHM J	
R191	RD-AZ331J	R CARBON FILM	1/6 330 OHM J	
R301	RD-AZ472J	R CARBON FILM	1/4 4.7K OHM J	
R310	RD-AZ392J	R CARBON FILM	1/6 3.9K OHM J	
R311	RD-AZ392J	R CARBON FILM	1/6 3.9K OHM J	
R330	RD-AZ473J	R CARBON FILM	1/4 4.7K OHM J	
R331	RD-AZ201J	R CARBON FILM	1/2 200 OHM J	
R333	RD-AZ222J	R CARBON FILM	1/6 2.2K OHM J	
R334	RD-AZ222J	R CARBON FILM	1/6 2.2K OHM J	
R340	RD-AZ334J	R CARBON FILM	1/4 330K OHM J	
R341	RD-AZ333J	R CARBON FILM	1/4 33K OHM J	
R350	RD-AZ272J	R CARBON FILM	1/4 2.7K OHM J	
R351	RD-AZ272J	R CARBON FILM	1/4 2.7K OHM J	
R370	RD-AZ159J	R CARBON FILM	1/4 1.5 OHM J	
R394	RD-AZ272J	R CARBON FILM	1/6 2.7K OHM J	
R395	RD-AZ394J	R CARBON FILM	1/4 390K OHM J	
R396	RD-AZ272J	R CARBON FILM	1/6 2.7K OHM J	
R397	RD-AZ104J	R CARBON FILM	1/6 100K OHM J	
R401	RD-AZ272J	R CARBON FILM	1/4 2.7K OHM J	
R402	RD-AZ220J	R CARBON FILM	1/4 22 OHM J	
R404	RD-AZ399J	R CARBON FILM	1/2 3.9 OHM J	
R406	RD-AZ821J	R CARBON FILM	1/2 820 OHM J	
R420	RD-AZ152J	R CARBON FILM	1/2 1.5K OHM J	
R444	85801065GY	WIRE COPPER	AWG22 1/0.65 TIN COATING	
R490	RD-AZ101J	R CARBON FILM	1/4 100 OHM J	
R500	RD-AZ101J	R CARBON FILM	1/6 100 OHM J	
R501	RD-AZ101J	R CARBON FILM	1/6 100 OHM J	
R502	RD-AZ101J	R CARBON FILM	1/6 100 OHM J	
R503	RD-AZ101J	R CARBON FILM	1/6 100 OHM J	
R504	RD-AZ473J	R CARBON FILM	1/6 4.7K OHM J	
R506	RD-AZ223J	R CARBON FILM	1/6 22K OHM J	
R507	RD-AZ562J	R CARBON FILM	1/6 5.6K OHM J	
R508	RD-AZ562J	R CARBON FILM	1/6 5.6K OHM J	
R509	RD-AZ472J	R CARBON FILM	1/6 4.7K OHM J	
R511	RD-AZ133J	R CARBON FILM	1/6 13K OHM J	
R512	RD-AZ133J	R CARBON FILM	1/6 13K OHM J	
R513	85801065GY	WIRE COPPER	AWG22 1/0.65 TIN COATING	
R517	RD-AZ102J	R CARBON FILM	1/6 1K OHM J	
R518	RD-AZ102J	R CARBON FILM	1/6 1K OHM J	
R530	RD-AZ103J	R CARBON FILM	1/6 10K OHM J	
R532	RD-AZ223J	R CARBON FILM	1/6 22K OHM J	
R533	RD-AZ103J	R CARBON FILM	1/6 10K OHM J	
R535	RD-AZ201J	R CARBON FILM	1/6 200 OHM J	
R537	RD-AZ201J	R CARBON FILM	1/6 200 OHM J	
R540	RD-AZ101J	R CARBON FILM	1/6 100 OHM J	
R541	RD-AZ122J	R CARBON FILM	1/6 1.2K OHM J	

Service Manual WP-895/895F, CP885/885F, CP485F

LOC	PART CODE	PART NAME	DESCRIPTION	REMARK
R542	RD-AZ223J-	R CARBON FILM	1/6 22K OHM J	
R543	RD-AZ271J-	R CARBON FILM	1/6 270 OHM J	
R544	RD-AZ222J-	R CARBON FILM	1/6 2.2K OHM J	
R548	RD-AZ103J-	R CARBON FILM	1/6 10K OHM J	
R550	RD-AZ102J-	R CARBON FILM	1/6 1K OHM J	
R555	RD-AZ102J-	R CARBON FILM	1/6 1K OHM J	
R560	RD-AZ101J-	R CARBON FILM	1/6 100 OHM J	
R561	RD-AZ101J-	R CARBON FILM	1/6 100 OHM J	
R562	RD-AZ152J-	R CARBON FILM	1/6 1.5K OHM J	
R563	RD-AZ152J-	R CARBON FILM	1/6 1.5K OHM J	
R566	RD-AZ220J-	R CARBON FILM	1/6 22 OHM J	
R568	RD-AZ102J-	R CARBON FILM	1/6 1K OHM J	
R569	RD-AZ181J-	R CARBON FILM	1/6 180 OHM J	
R570	RD-AZ271J-	R CARBON FILM	1/6 270 OHM J	
R572	RD-AZ101J-	R CARBON FILM	1/6 100 OHM J	
R573	RD-AZ101J-	R CARBON FILM	1/6 100 OHM J	
R576	RD-AZ181J-	R CARBON FILM	1/6 180 OHM J	
R577	RD-AZ181J-	R CARBON FILM	1/6 180 OHM J	
R578	RD-AZ330J-	R CARBON FILM	1/6 33 OHM J	
R579	RD-AZ330J-	R CARBON FILM	1/6 33 OHM J	
R580	RD-AZ271J-	R CARBON FILM	1/6 270 OHM J	
R582	RD-AZ101J-	R CARBON FILM	1/6 100 OHM J	
R583	RD-AZ101J-	R CARBON FILM	1/6 100 OHM J	
R586	RD-AZ271J-	R CARBON FILM	1/6 270 OHM J	
R587	RD-AZ101J-	R CARBON FILM	1/6 100 OHM J	
R588	RD-AZ101J-	R CARBON FILM	1/6 100 OHM J	
R589	RD-AZ330J-	R CARBON FILM	1/6 33 OHM J	
R591	RD-AZ431J-	R CARBON FILM	1/6 430 OHM J	
R592	RD-AZ102J-	R CARBON FILM	1/6 1K OHM J	
R593	RD-AZ104J-	R CARBON FILM	1/6 100K OHM J	
R594	RD-AZ222J-	R CARBON FILM	1/6 2.2K OHM J	
R595	RD-AZ682J-	R CARBON FILM	1/6 6.8K OHM J	
R596	RD-AZ472J-	R CARBON FILM	1/6 4.7K OHM J	
R597	RN-4Z1502F	R METAL FILM	1/4 15K OHM F	
R598	RN-4Z1502F	R METAL FILM	1/4 15K OHM F	
R599	RD-AZ101J-	R CARBON FILM	1/6 100 OHM J	
R601	RD-AZ101J-	R CARBON FILM	1/6 100 OHM J	
R602	RD-AZ104J-	R CARBON FILM	1/6 100K OHM J	
R605	RD-AZ101J-	R CARBON FILM	1/6 100 OHM J	
R606	RD-AZ101J-	R CARBON FILM	1/6 100 OHM J	
R608	RD-2Z151J-	R CARBON FILM	1/2 150 OHM J	
R609	RD-2Z151J-	R CARBON FILM	1/2 150 OHM J	
R614	RD-AZ102J-	R CARBON FILM	1/6 1K OHM J	
R615	RD-AZ102J-	R CARBON FILM	1/6 1K OHM J	
R620	RD-AZ102J-	R CARBON FILM	1/6 1K OHM J	
R621	RD-AZ102J-	R CARBON FILM	1/6 1K OHM J	
R622	RD-AZ102J-	R CARBON FILM	1/6 1K OHM J	
R641	RD-AZ102J-	R CARBON FILM	1/6 1K OHM J	
R642	RD-AZ102J-	R CARBON FILM	1/6 1K OHM J	
R646	RD-AZ102J-	R CARBON FILM	1/6 1K OHM J	
R647	RD-AZ102J-	R CARBON FILM	1/6 1K OHM J	
R649	RD-AZ102J-	R CARBON FILM	1/6 1K OHM J	
R650	RD-AZ752J-	R CARBON FILM	1/6 7.5K OHM J	
R651	RD-AZ102J-	R CARBON FILM	1/6 1K OHM J	
R652	RD-AZ102J-	R CARBON FILM	1/6 1K OHM J	
R660	RD-AZ752J-	R CARBON FILM	1/6 7.5K OHM J	
R661	RD-AZ123J-	R CARBON FILM	1/6 12K OHM J	
R662	RD-AZ123J-	R CARBON FILM	1/6 12K OHM J	
R700	RD-2Z332J-	R CARBON FILM	1/2 3.3K OHM J	
R709	RD-AZ102J-	R CARBON FILM	1/6 1K OHM J	
R710	RD-AZ102J-	R CARBON FILM	1/6 1K OHM J	

LOC	PART CODE	PART NAME	DESCRIPTION	REMARK
R711	RD-AZ103J-	R CARBON FILM	1/6 10K OHM J	
R712	RD-AZ181J-	R CARBON FILM	1/6 180 OHM J	
R713	RD-AZ331J-	R CARBON FILM	1/6 330 OHM J	
R720	RD-AZ122J-	R CARBON FILM	1/6 1.2K OHM J	
R721	RD-AZ181J-	R CARBON FILM	1/6 180 OHM J	
R722	RD-AZ221J-	R CARBON FILM	1/6 220 OHM J	
R723	RD-AZ331J-	R CARBON FILM	1/6 330 OHM J	
R724	RD-AZ471J-	R CARBON FILM	1/6 470 OHM J	
R805	RD-2Z100J-	R CARBON FILM	1/2 10 OHM J	
R806	RD-2Z472J-	R CARBON FILM	1/2 4.7K OHM J	
R807	RD-2Z272J-	R CARBON FILM	1/2 2.7K OHM J	
R808	RD-2Z821J-	R CARBON FILM	1/2 820 OHM J	
R810	RD-AZ102J-	R CARBON FILM	1/4 1K OHM J	
R811	RC-2Z565KP	R CARBON COMP	1/2 5.6M OHM K	
R817	RD-AZ473J-	R CARBON FILM	1/6 47K OHM J	
R820	RD-AZ102J-	R CARBON FILM	1/6 1K OHM J	
R821	RD-4Z102J-	R CARBON FILM	1/4 1K OHM J	
R823	RD-2Z272J-	R CARBON FILM	1/2 2.7K OHM J	
R829	RD-AZ103J-	R CARBON FILM	1/6 10K OHM J	
R830	RD-AZ332J-	R CARBON FILM	1/6 3.3K OHM J	
R841	RD-2Z470J-	R CARBON FILM	1/2 47 OHM J	
R851	RD-AZ391J-	R CARBON FILM	1/6 390 OHM J	
R852	RD-AZ102J-	R CARBON FILM	1/6 1K OHM J	
R855	RD-4Z335J-	R CARBON FILM	1/4 3.3M OHM J	
R870	RD-2Z222J-	R CARBON FILM	1/2 2.2K OHM J	
R901	RD-AZ221J-	R CARBON FILM	1/6 220 OHM J	
R902	RD-AZ221J-	R CARBON FILM	1/6 220 OHM J	
R903	RD-AZ221J-	R CARBON FILM	1/6 220 OHM J	
R910	RD-AZ101J-	R CARBON FILM	1/6 100 OHM J	
R911	RD-AZ101J-	R CARBON FILM	1/6 100 OHM J	
R912	RD-AZ101J-	R CARBON FILM	1/6 100 OHM J	
R913	RD-AZ101J-	R CARBON FILM	1/6 100 OHM J	
R921	RC-2Z102K-	R CARBON COMP	1/2 1K OHM K	
R922	RC-2Z102K-	R CARBON COMP	1/2 1K OHM K	
R923	RC-2Z102K-	R CARBON COMP	1/2 1K OHM K	
R983	RD-4Z472J-	R CARBON FILM	1/4 4.7K OHM J	
R996	RD-2Z105J-	R CARBON FILM	1/2 1M OHM J	
R997	RD-2Z102J-	R CARBON FILM	1/2 1K OHM J	
RA1	RD-AZ220J-	R CARBON FILM	1/6 22 OHM J	
RA10	RD-AZ101J-	R CARBON FILM	1/6 100 OHM J	
RA11	RD-AZ750J-	R CARBON FILM	1/6 75 OHM J	
RA12	RD-AZ750J-	R CARBON FILM	1/6 75 OHM J	
RA13	RD-AZ113J-	R CARBON FILM	1/6 11K OHM J	
RA14	RD-AZ750J-	R CARBON FILM	1/6 75 OHM J	
RA16	RD-AZ750J-	R CARBON FILM	1/6 75 OHM J	
RA19	RD-AZ750J-	R CARBON FILM	1/6 75 OHM J	
RA2	RD-AZ101J-	R CARBON FILM	1/6 100 OHM J	
RA29	RD-AZ102J-	R CARBON FILM	1/6 1K OHM J	
RA3	RD-AZ101J-	R CARBON FILM	1/6 100 OHM J	
RA32	RD-AZ680J-	R CARBON FILM	1/6 68 OHM J	
RA4	RD-AZ101J-	R CARBON FILM	1/6 100 OHM J	
RA44	RD-AZ113J-	R CARBON FILM	1/6 11K OHM J	
RA5	RD-AZ333J-	R CARBON FILM	1/6 33K OHM J	
RA6	RD-AZ750J-	R CARBON FILM	1/6 75 OHM J	
RA7	RD-AZ333J-	R CARBON FILM	1/6 33K OHM J	
RA8	RD-AZ750J-	R CARBON FILM	1/6 75 OHM J	
RA9	RD-AZ750J-	R CARBON FILM	1/6 75 OHM J	
RA90	RD-AZ220J-	R CARBON FILM	1/6 22 OHM J	
RA91	RD-AZ473J-	R CARBON FILM	1/6 47K OHM J	
RA92	RD-AZ223J-	R CARBON FILM	1/6 22K OHM J	

6. Service Parts List (DTB-21U7)

CAUTION

“△” Parts recommended for stock.

“⊗” Safety critical componen, Replace only with genuine Daewoo safety parts.

LOC	PART CODE	PART NAME	DESCRIPTION	REMARK
ZZ110	PTACPWB21U7FS	ACCESSORY AS	DTB-21U7ZF-S	
00030	4850Q00910	BATTERY	AAA R03/NN SUPERGARD	
M751	4857539601	COVER JACK	21U7 ABS GY	
M821	4858213801	BAG INSTRUCTION	L. D. P. E. TO. 05X250X40	
ZZ100	48B4846G22	TRANSMITTER REMOCON	R-46G22	⊗
ZZ120	PTBSCSHB21U7S	COVER BACK AS	DTB-21U7ZF-S	
M211	4852161901	COVER BACK	21U7 HIPS GY	
M541	4855415800	SP/LATE	150ART P/E FILM (C/TV)	
M542	4855800022	LABEL SERIAL	ART 90 70X19	
M781	4857817610	CLOTH BLACK	"300 MM 20"	
ZZ130	PTCACAB21U7FFS	CABINET AS	DTB-21U7ZF-S	
20	2193011101	SOLDER WIRE	RS 60-1.2 1.6A	
30	2224050001	BOND	TB-2507	
40	4856812001	TIE CABLE	NYLON66 DA100	
M191	4851947101	BUTTON CYRL AS	21U7 4952901+5547601	
M191A	7178301011	SCREW TAPPING	TT2 WAS 3X10 MFZN	
M201A	4856013300	SCREW CRT FIXING AS	L-80	
M201B	4856215402	WASHER RUBBER	20"	
M201C	4856013302	SCREW CRT FIXING AS	L-190	
M211A	7172401612	SCREW TAPPING	TT2 TRS 4X16 MFZN BK	
M211B	7178301211	SCREW TAPPITE	TT2 WAS 3X12 MFZN	
M481	4854862501	BUTTON POWER	21U7 ABS GY	
M481A	4856716000	SPRING	14QT1M3 SWPA PIE0.5	
M561	48556175SD01	MARK BRAND	DAEWOO 2115 (SILVER)	
P402A	4850704N07	CONNECTOR	SE100J+172792+USW=500	
PWC1	4859906210	CORD POWER	W/F 6-LO (LOMAX NEW)	
SP01A	7178301011	SCREW TAPPING	TT2 WAS 3X10 MFZN	
SP02A	7178301011	SCREW TAPPING	TT2 WAS 3X10 MFZN	
V901	4859637360	"CRT (PHILIPS 21") "	A51ERF135X80 (FLAT)	⊗ △
ZZ131	58G0000147	COIL DE GAUSSING	DC-21SF	⊗ △
ZZ132	48519A5210	CRT GROUND AS	21A5	
ZZ200	PTFMSJB21U7S	MASK FRONT AS	DTB-21U7ZF-S	
M801	4852081201	MASK FRONT	21U7 HIPS GY	
ZZ210	PTSPWB21U7FS	SPEAKER AS	DTB-21U7ZF-S	
P601A	4850704S28	CONN AS	YH025-04-35089+ULW=600	
SP01	4858314910	SPLAKER	SP-33129A03	⊗
SP02	4858314910	SPEAKER	SP-33129A03	⊗
ZZ290	PTMPMSB21U7FF	PCB MAIN MANUAL AS	DTB-21U7ZF-S	
10	2191300801	SOLDER BAR	SN/PB=63.37 3PI(NO FLUX)	
40	2291050314	FLUX SOLVENT	IM-1000	
20	2193011101	SOLDER WIRE	RS 60-1.2 1.6A	
30	2291050617P	FLUX SOLDER	CF-329D	
50	2291140501	WAX COVER	60G/PC	
60	2291051001	FLUX KILLER	KF1-7	
C106	CEXF1H221V	C ELECTRO	50V RSS 220MF (10X16) TP	
C118	CMXL1J474J	C MYLAR	63V 0.47MF MKT	
C315	CEXF2A470V	C ELECTRO	100V RSS 47MF (10X16) TP	
C402	CMYH3C622J	C MYLAR	1.6KV 6200PF J (BUP)	
C408	CMYE2G304J	C MYLAR	400V 0.3MF J (PL)	
C415	CEXF2E479V	C ELECTRO	250V RSS 4.7MF (10X16)TP	
C430	CCXB3D681K	C CERA	2KV B 680PF K (TAPPING)	
C431	CMXM2A103J	C MYLAR	100V 0.01MF J (1P)	
C604	CEXF1E102V	C ELECTRO	25V RSS 1000MF (13X20) TP	
C801	CL1UC3474M	C LINE ACROSS	0.47MF 1J(UCVSNDP/SV	△
C805	CEYN2G121P	C ELECTRO	400V LHS 120MF	
C811	CCYR3D681K	C CERA	2KV R 680PF K 125C	
C812	CHTBFE472M	C CERA AC	AC400V 4700PF M U/C/V	△
C813	CEXF2E101V	C ELECTRO	250V RSS 1000MF 18X35.5	
C814	CEYF2E470V	C ELECTRO	250V RSS 47MF (16X25	
C820	CCYR3A471K	C CERA	1KV 470PF K 125C	
C823	CEXF1E102V	C ELECTRO	25V RSS 1000MF (13X20) TP	
C832	CEXF1E102V	C ELECTRO	25V RSS 1000MF (13X20) TP	
C840	CEXF1C222V	C ELECTRO	16V RSS 2200MF (13X25)1P	
C841	CEXF1C332V	C ELECTRO	16V RSS 3300MF	
C861	CEXF1E102C	C ELECTRO	25V RUS 1000MF 13X20 TP	
C866	CCYR3A471K	C CERA	1KV 470PF K 125C	
C900	CCXB3D102K	C CERA	2KV B 1000 PF K (TAPPING)	

LOC	PART CODE	PART NAME	DESCRIPTION	REMARK
C910	CEXF2E479V	C ELECTRO	250V RSS 4.7MF (10X16)TP	
C997	CEXF2E100V	C ELECTRO	250V RSS 10MF (10X20) TP	
D403	DDG3-----	DIODE	DG3	
D820	DRGP30J---	DIODE	RGP30J	
D860	DRGP30J---	DIODE	RGP30J	
F801	5FSCB4022R	FUSE CERA	SEMKO F4AH 4A 250V MF51	△
G900	4SGODX0001	SPARK GAP	SSG-102-A1 (1.0KV)	
I101	1TDA4470M-	IC IF	TDA4470-M	
I301	1TDA8358J-	IC VERTICAL	TDA8358J	⊗
I301A	4857024421	HEAT SINK	I602A (CP-385)	
I301B	7174301011	SCREW TAPPITTE	TT2 RND 3X10 MFZN	
I501	1TDW3834AE2	IC MICOM	DW3834A C4 AE2	⊗
I601	1MSP3410V3	IC SOUND	MSP3410G-V3	⊗
I602	1TDA8944J-	IC AUDIO	TDA8944J	⊗
I602A	4857024421	HEAT SINK	I602A (CP-385)	
I602B	7174301011	SCREW TAPPITTE	TT2 RND 3X10 MFZN	
I702	1AT24C16PC	IC MEMORY	AT24C16-10PC	⊗
I703	1TS0P1238W	IC PREAMP	TSOP1238WI1	⊗
I801	1STRF6654-	IC SMPS	STR-F6654	⊗
I801A	4857027701	HEAT SINK	AL EX	
I801B	7174300811	SCREW TAPPITTE	TT2 RND 3X8 MFZN	
I804	1KP1010C--	IC PHOTO COUPLER	KP-1010C	△
I806	1SE110N---	IC	SE110N	⊗
I810	1X0202DA--	THYRISTOR	X0202DA	⊗
I820	1L7805CV--	IC REGULATOR	L7805CV	
I822	1L7808CV--	IC REGULATOR	L7808CV	
I823	1L7805CV--	IC REGULATOR	L7805CV	
I901	1TDA6107Q-	IC VIDEO	TDA6107Q	⊗
I901A	4857031100	HEAT SINK	A1050P-H24 T2.0	
I901B	7174300811	SCREW TAPPITTE	TT2 RND 3X8 MFZN	
JP01	4859102130	JACK EARPHONE	YSC-1537	
JPA1	4859200401	SOCKET RGB	SR-21A1 (ANGLE TYPE)	
JPA2	4859200401	SOCKET RGB	SR-21A1 (ANGLE TYPE)	
JPA3	4859108450	JACK PIN BOARD	YSC03P-4120-14A	
L150	58E0000041	COIL AFT	TRF-A005	⊗
L380	58C0000120	COIL CHOKE	CH-100C	
L381	58C0000120	COIL CHOKE	CH-100C	
L401	58H0000016	COIL H-LINEARITY	L-102 (102UH)	
L802	58C9430599	COIL CHOKE	AZ-9004Y(94MH)	
LF801	5PLF24A1--	FILTER LINE	LF-24A1	
M351	4858900002	HOLDER LED AS	LH-3P	
M601	4856813600	HOLDER WIRE	NYLON 66 DAWH-13NA	
P401	4850706N08	CONNECTOR	6PIN 500MM BOARD IN TYPE	
P402	4859242420	CONN WAFER	YFW800-04	
P501	4850705N14	CONNECTOR	BIC-051-25T+ULW=500	
P601	4859231720	CONN WAFER	YW025-04	
P801	4859287320	CONN WAFER	MKS2822 (LOMAX NEW TYPE)	
P802	4859242220	CONN WAFER	YFW800-02	
P905	4859262120	CONN WAFER	YFW 800-01 A5MODELS	
Q401	12SD2578--	TR	2SD2578	
R415	RS02Y102JS	R M-OXIDE FILM	2W 1K OHM J SMALL	
R450	RS02Y223JS	R M-OXIDE FILM	2W 22K OHM J SMALL	
R801	DPC1R0M290	POSISTOR	96709 (BC)	
R802	RS02Y683JS	R M-OXIDE FILM	2W 68K OHM J SMALL	
R803	RS02Y473JS	R M-OXIDE FILM	2W 47K OHM J SMALL	
R804	RF02Y228K-	R FUSIBLE	2W 0.22 OHM K	
R819	RX10B339JN	R CEMENT	10W 3.3 OHM J BENCH 4P	⊗
R850	RS02Y309JS	R M-OXIDE FILM	2W 3 OHM J SMALL	
R888	RD-42273J-	R CARBON FILM	1/4 27K OHM J	
R906	RF01Y209JA	R FUSIBLE	1W 2 OHM J A CURVE	△
SCT1	4859303530	SOCKET CRT	PCS629-03C	
SF1	5PK3953M--	FILTER SAW	K3953M	
SF2	5PK9650M--	FILTER SAW	K9650M	
SW801	5S40101143	SW PUSH	PS3-22SP (P.C.B)	
T401	50D19A1--	TRANS DRIVE	1D-19A1	
T402	50H0000240	FBT	1152.7001	⊗ △
T801	50M3934A9-	TRANS SMPS	2084.0090	⊗ △
U100	4859722430	TUNER VARACTOR	UV1316/AIG-3	⊗
X501	5XE20R250E	CRYSTAL QUARTZ	HC-49/U 20.2500MHZ 30PPM	

Service manual WP 895/895F, CP885/885F, CP485F

LOC	PART CODE	PART NAME	DESCRIPTION	REMARK
X601	5XE18R432E	CRYSTAL QUARTZ	HC-49/U 18.43200MHZ 30PPM	
Z153	5PYXT5R5MB	FILTER CERA	XT5.5MB	
Z2200	PTMPJBB21U7FF	PCB MAIN EYE LET AS	DTB-21U7ZF-S	
E001	4856310600	EYE LET	BSR 2.3(R2.3)	
E002	4856310600	EYE LET	BSR 2.3(R2.3)	
E003	4856310600	EYE LET	BSR 2.3(R2.3)	
E004	4856310600	EYE LET	BSR 2.3(R2.3)	
E005	4856310300	EYE LET	BSR T0.2 (R1.6)	
E006	4856310300	EYE LET	BSR T0.2 (R1.6)	
E007	4856310300	EYE LET	BSR T0.2 (R1.6)	
E008	4856310300	EYE LET	BSR T0.2 (R1.6)	
E009	4856310600	EYE LET	BSR 2.3(R2.3)	
E010	4856310600	EYE LET	BSR 2.3(R2.3)	
E012	4856310600	EYE LET	BSR 2.3(R2.3)	
E013	4856310600	EYE LET	BSR 2.3(R2.3)	
E018	4856310300	EYE LET	BSR T0.2 (R1.6)	
E019	4856310300	EYE LET	BSR T0.2 (R1.6)	
E020	4856310300	EYE LET	BSR T0.2 (R1.6)	
E021	4856310600	EYE LET	BSR 2.3(R2.3)	
E022	4856310600	EYE LET	BSR 2.3(R2.3)	
E023	4856310300	EYE LET	BSR T0.2 (R1.6)	
E024	4856310300	EYE LET	BSR T0.2 (R1.6)	
E025	4856310600	EYE LET	BSR 2.3(R2.3)	
E026	4856310600	EYE LET	BSR 2.3(R2.3)	
E027	4856310600	EYE LET	BSR 2.3(R2.3)	
E028	4856310600	EYE LET	BSR 2.3(R2.3)	
E029	4856310600	EYE LET	BSR 2.3(R2.3)	
E030	4856310600	EYE LET	BSR 2.3(R2.3)	
E031	4856310300	EYE LET	BSR T0.2 (R1.6)	
E032	4856310300	EYE LET	BSR T0.2 (R1.6)	
E033	4856310300	EYE LET	BSR T0.2 (R1.6)	
E034	4856310300	EYE LET	BSR T0.2 (R1.6)	
E035	4856310300	EYE LET	BSR T0.2 (R1.6)	
E038	4856310600	EYE LET	BSR 2.3(R2.3)	
Z2200	PTMPJRB21U7FF	PCB MAIN RADIAL AS	DTB-21U7ZF-S	
C102	CEXF1E470V	C ELECTRO	25V RSS 47MF (5X11) TP	
C110	CXCH1H150J	C CERA	50V CH 15PF J (TAPPING)	
C117	CEXF1H229V	C ELECTRO	50V RSS 2.2MF (5X11) TP	
C121	CEXF1H100V	C ELECTRO	50V RSS 10MF (5X11) TP	
C122	CEXF1E100V	C ELECTRO	25V RSS 10MF TP	
C152	CEXF1E100V	C ELECTRO	25V RSS 10MF TP	
C153	CEXF1H229V	C ELECTRO	50V RSS 2.2MF (5X11) TP	
C156	CBXF1H104Z	C CERA SEMI	50V F 0.1MF Z (TAPPING)	
C157	CEXF1E100V	C ELECTRO	25V RSS 10MF TP	
C158	CBXF1H104Z	C CERA SEMI	50V F 0.1MF Z (TAPPING)	
C164	CEXF1E470V	C ELECTRO	25V RSS 47MF (5X11) TP	
C301	CMXM2A224J	C MYLAR	100V 0.22MF J BULK	
C305	CEXF1E221V	C ELECTRO	25V RSS 220MF (8X11.5) TP	
C313	CMXM2A104J	C MYLAR	100V 0.1MF J TP	
C320	CBXF1H104Z	C CERA SEMI	50V F 0.1MF Z (TAPPING)	
C350	CCXF1H103Z	C CERA	50V F 0.01MF Z (TAPPING)	
C351	CCXF1H103Z	C CERA	50V F 0.01MF Z (TAPPING)	
C370	CCXF1H473Z	C CERA	50V F 0.047MF Z (TAPPING)	
C401	CEXF1H101V	C ELECTRO	50V RSS 100MF (8*11.5) TP	
C412	CEXF2C339V	C ELECTRO	160V RSS 3.3MF (8X16) TP	
C418	CCXB1H102K	C CERA	50V B 1000PF K (TAPPING)	
C420	CCXB2H222K	C CERA	500V B 2200PF K (TAPPING)	
C424	CMXM2A333J	C MYLAR	100V 0.033MF J TP	
C502	CEXF1E101V	C ELECTRO	25V RSS 100MF (6.3X11) TP	
C504	CEXF1E470V	C ELECTRO	25V RSS 47MF (5X11) TP	
C508	CEXF1H220V	C ELECTRO	50V RSS 22MF (5X11) TP	
C510	CCXF1H473Z	C CERA	50V F 0.047MF Z (TAPPING)	
C511	CEXF1E100V	C ELECTRO	25V RSS 10MF TP	
C519	CEXF1H109V	C ELECTRO	50V RSS 1MF (5X11) TP	
C520	CEXF1H109V	C ELECTRO	50V RSS 1MF (5X11) TP	
C521	CEXF1H109V	C ELECTRO	50V RSS 1MF (5X11) TP	
C522	CEXF1H109V	C ELECTRO	50V RSS 1MF (5X11) TP	
C525	CEXF1H220V	C ELECTRO	50V RSS 22MF (5X11) TP	
C528	CCXF1H223Z	C CERA	50V F 0.022MF Z (TAPPING)	
C529	CCXF1H223Z	C CERA	50V F 0.022MF Z (TAPPING)	
C530	CCXF1H223Z	C CERA	50V F 0.022MF Z (TAPPING)	
C546	CEXF1H339V	C ELECTRO	50V RSS 3.3MF (5X11) TP	
C547	CBXF1H104Z	C CERA SEMI	50V F 0.1MF Z (TAPPING)	
C549	CEXF1H229V	C ELECTRO	50V RSS 2.2MF (5X11) TP	
C553	CEXF1E101V	C ELECTRO	25V RSS 100MF (6.3X11) TP	
C597	CEXF1H220V	C ELECTRO	50V RSS 22MF (5X11) TP	
C602	CEXF1E221V	C ELECTRO	25V RSS 220MF (8X11.5) TP	
C605	CEXF1E470V	C ELECTRO	25V RSS 47MF (5X11) TP	
C608	CEXF1E100V	C ELECTRO	25V RSS 10MF TP	
C610	CEXF1E100V	C ELECTRO	25V RSS 10MF TP	
C611	CEXF1H339V	C ELECTRO	50V RSS 3.3MF (5X11) TP	
C612	CEXF1H109V	C ELECTRO	50V RSS 1MF (5X11) TP	

LOC	PART CODE	PART NAME	DESCRIPTION	REMARK
C613	CEXF1H109V	C ELECTRO	50V RSS 1MF (5X11) TP	
C614	CEXF1H109V	C ELECTRO	50V RSS 1MF (5X11) TP	
C615	CEXF1H109V	C ELECTRO	50V RSS 1MF (5X11) TP	
C616	CEXF1E100V	C ELECTRO	25V RSS 10MF TP	
C617	CBXF1H104Z	C CERA SEMI	50V F 0.1MF Z (TAPPING)	
C622	CXCH1H680J	C CERA	50V CH 68PF J (TAPPING)	
C623	CEXF1H109V	C ELECTRO	50V RSS 1MF (5X11) TP	
C624	CEXF1H109V	C ELECTRO	50V RSS 1MF (5X11) TP	
C625	CEXF1E101V	C ELECTRO	25V RSS 100MF (6.3X11) TP	
C626	CEXF1E101V	C ELECTRO	25V RSS 100MF (6.3X11) TP	
C629	CBXF1H104Z	C CERA SEMI	50V F 0.1MF Z (TAPPING)	
C630	CEXF1E470V	C ELECTRO	25V RSS 47MF (5X11) TP	
C634	CEXF1E100V	C ELECTRO	25V RSS 10MF TP	
C635	CCXB1H102K	C CERA	50V B 1000PF K (TAPPING)	
C636	CEXF1E470V	C ELECTRO	25V RSS 47MF (5X11) TP	
C641	CEXF1E101V	C ELECTRO	25V RSS 100MF (6.3X11) TP	
C642	CEXF1E101V	C ELECTRO	25V RSS 100MF (6.3X11) TP	
C660	CEXF1C100A	C ELECTRO	16V RSS 100MF 5X7	
C661	CMXM2A224J	C MYLAR	100V 0.22MF J BULK	
C662	CMXM2A224J	C MYLAR	100V 0.22MF J BULK	
C665	CCXB1H472K	C CERA	50V B 4700PF K (TAPPING)	
C666	CBXF1H104Z	C CERA SEMI	50V F 0.1MF Z (TAPPING)	
C667	CCXB1H472K	C CERA	50V B 4700PF K (TAPPING)	
C668	CMXM2A224J	C MYLAR	100V 0.22MF J BULK	
C669	CMXM2A224J	C MYLAR	100V 0.22MF J BULK	
C690	CEXF1H479V	C ELECTRO	50V RSS 4.7MF (5*11) TP	
C691	CEXF1H479V	C ELECTRO	50V RSS 4.7MF (5*11) TP	
C770	CEXF1C101V	C ELECTRO	16V RSS 100MF (6.3X11) TP	
C803	CCXF3A472Z	C CERA	1KV F 4700PF Z (T)	
C804	CCXF3A472Z	C CERA	1KV F 4700PF Z (T)	
C806	CEXF1H220V	C ELECTRO	50V RSS 22MF (5X11) TP	
C807	CCXF1H473Z	C CERA	50V F 0.047MF Z (TAPPING)	
C808	CEXF1H479V	C ELECTRO	50V RSS 4.7MF (5*11) TP	
C809	CCXB1H102K	C CERA	50V B 1000PF K (TAPPING)	
C821	CCXB1H102K	C CERA	50V B 1000PF K (TAPPING)	
C824	CCXB3A471K	C CERA	1KV B 470PF K (T)	
C831	CCXB3A471K	C CERA	1KV B 470PF K (T)	
C835	CEXF1E470V	C ELECTRO	25V RSS 47MF (5X11) TP	
C844	CEXF1E101V	C ELECTRO	25V RSS 100MF (6.3X11) TP	
C850	CCXB1H821K	C CERA	50V B 820PF K (TAPPING)	
C863	CEXF1E101V	C ELECTRO	25V RSS 100MF (6.3X11) TP	
C888	CEXF1C470V	C ELECTRO	16V RSS 47MF (5X11) TP	
C902	CMXL2E104K	C MYLAR	250V 0.1MF K MEU TP	
F801A	4857415001	CLIP FUSE	PF05000-0702	
F801B	4857415001	CLIP FUSE	PF05000-0702	
L101	5CPX479K--	COIL PEAKING	4.7UH K RADIAL	
Q103	I2SC5343Y-	TR	2SC5343Y	
Q104	I2SC5343Y-	TR	2SC5343Y	
Q120	I2SC5343Y-	TR	2SC5343Y	
Q150	I2SC5343Y-	TR	2SC5343Y	
Q151	I2SC5343Y-	TR	2SC5343Y	
Q402	I2SD1207-I	TR	2SD1207-I (TAPPING)	
Q510	I2SC5343Y-	TR	2SC5343Y	
Q511	I2SC5343Y-	TR	2SC5343Y	
Q542	I2SA1980Y-	TR	2SA1980Y	
Q543	I2SA1980Y-	TR	2SA1980Y	
Q544	I2SA1980Y-	TR	2SA1980Y	
Q550	I2SC5343Y-	TR	2SC5343Y	
Q599	I2SA1980Y-	TR	2SA1980Y	
Q601	I2SA1980Y-	TR	2SA1980Y	
Q701	I2SC5343Y-	TR	2SC5343Y	
Q702	I2SA1980Y-	TR	2SA1980Y	
Q807	I2SC5343Y-	TR	2SC5343Y	
Q808	I2SC5343Y-	TR	2SC5343Y	
Q809	I2SC5343Y-	TR	2SC5343Y	
Q810	I2SC5343Y-	TR	2SC5343Y	
Q811	I2SC5343Y-	TR	2SC5343Y	
Q850	I2SC5343Y-	TR	2SC5343Y	
Q851	I2SC5343Y-	TR	2SC5343Y	
QA01	I2SC5343Y-	TR	2SC5343Y	
RB10	RV5426103P	R SEMI FIXED	RH0638C 10K OHM B	
SW700	5S50101090	SW TACT	SKHV17910A	
SW701	5S50101090	SW TACT	SKHV17910A	
SW702	5S50101090	SW TACT	SKHV17910A	
SW703	5S50101090	SW TACT	SKHV17910A	
SW704	5S50101090	SW TACT	SKHV17910A	
Z601	5PXF1B471M	FILTER EMI	CFI 06 B 1H 470PF	
Z602	5PXF1B471M	FILTER EMI	CFI 06 B 1H 470PF	
Z603	5PXF1B471M	FILTER EMI	CFI 06 B 1H 470PF	
Z604	5PXF1B471M	FILTER EMI	CFI 06 B 1H 470PF	
Z605	5PXF1B471M	FILTER EMI	CFI 06 B 1H 470PF	
Z606	5PXF1B471M	FILTER EMI	CFI 06 B 1H 470PF	

Service manual WP 895/895F, CP885/885F, CP485F

LOC	PART CODE	PART NAME	DESCRIPTION	REMARK
Z607	5PXF1B471M	FILTER EMI	CFI06 B 1H 470PF	
Z608	5PXF1B471M	FILTER EMI	CFI06 B 1H 470PF	
Z2200	PTMPJAB21U7FF	PCB MAIN AXIAL AS	DTB-21U7ZF-S	
20	21M10006LB	TAPE MASKING	3M #232-MAP-C 6.2X2000M	
10	21M14006LB	TAPE MASKING	3M #232 6.0X2000M	
A001	4859806393	PCB MAIN	CP-485F 330X246XT1.6	
C101	CCZB1H101K	C CERA	50V B 100PF K (AXIAL)	
C103	CCZB1H102K	C CERA	50V B 1000PF K (AXIAL)	
C104	CCZB1H102K	C CERA	50V B 1000PF K (AXIAL)	
C116	CBZF1H104Z	C CERA SEMI	50V F 0.1MF Z (AXIAL)	
C119	CCZF1H103Z	C CERA	50V F 0.01MF Z	
C120	CCZB1H102K	C CERA	50V B 1000PF K (AXIAL)	
C151	CCZF1H103Z	C CERA	50V F 0.01MF Z	
C154	CCZF1H103Z	C CERA	50V F 0.01MF Z	
C160	CCZF1H103Z	C CERA	50V F 0.01MF Z	
C161	CZSL1H220J	C CERA	50V SL 22PF J (AXIAL)	
C163	CCZF1H103Z	C CERA	50V F 0.01MF Z	
C440	85801065GY	WIRE COPPER	AWG22 1/0.65 TIN COATING	
C500	CCZF1H103Z	C CERA	50V F 0.01MF Z	
C501	CCZF1H103Z	C CERA	50V F 0.01MF Z	
C503	CBZF1H104Z	C CERA SEMI	50V F 0.1MF Z (AXIAL)	
C505	CCZB1H102K	C CERA	50V B 1000PF K (AXIAL)	
C506	CBZF1H104Z	C CERA SEMI	50V F 0.1MF Z (AXIAL)	
C507	CCZF1H103Z	C CERA	50V F 0.01MF Z	
C509	CCZF1H103Z	C CERA	50V F 0.01MF Z	
C512	CCZF1H103Z	C CERA	50V F 0.01MF Z	
C516	CCZB1H102K	C CERA	50V B 1000PF K (AXIAL)	
C526	CBZF1H104Z	C CERA SEMI	50V F 0.1MF Z (AXIAL)	
C527	CCZB1H102K	C CERA	50V B 1000PF K (AXIAL)	
C534	CCZB1H333K	C CERA	50V B 0.033MF K (AXIAL)	
C535	CCZB1H333K	C CERA	50V B 0.033MF K (AXIAL)	
C536	CCZB1H333K	C CERA	50V B 0.033MF K (AXIAL)	
C548	CBZF1H104Z	C CERA SEMI	50V F 0.1MF Z (AXIAL)	
C554	CBZF1H104Z	C CERA SEMI	50V F 0.1MF Z (AXIAL)	
C560	CCZB1H101K	C CERA	50V B 100PF K (AXIAL)	
C561	CCZB1H101K	C CERA	50V B 100PF K (AXIAL)	
C568	CBZF1H104Z	C CERA SEMI	50V F 0.1MF Z (AXIAL)	
C571	CCZB1H101K	C CERA	50V B 100PF K (AXIAL)	
C578	CCZB1H221K	C CERA	50V B 220PF K (AXIAL)	
C579	CCZB1H221K	C CERA	50V B 220PF K (AXIAL)	
C581	CCZB1H101K	C CERA	50V B 100PF K (AXIAL)	
C585	CCZB1H101K	C CERA	50V B 100PF K (AXIAL)	
C589	CCZB1H221K	C CERA	50V B 220PF K (AXIAL)	
C590	CZCH1H309C	C CERA	50V CH 3PF C (AXIAL)	
C591	CZCH1H309C	C CERA	50V CH 3PF C (AXIAL)	
C601	CBZRTC472M	C CERA	Y5R 16V 4700PF M AXIAL	
C603	CBZRTC472M	C CERA	Y5R 16V 4700PF M AXIAL	
C620	CZCH1H309C	C CERA	50V CH 3PF C (AXIAL)	
C621	CZCH1H309C	C CERA	50V CH 3PF C (AXIAL)	
C631	CBZF1H104Z	C CERA SEMI	50V F 0.1MF Z (AXIAL)	
C650	CZSL1H680J	C CERA	50V SL 68PF J (AXIAL)	
C830	CBZF1H104Z	C CERA SEMI	50V F 0.1MF Z (AXIAL)	
CA01	CCZB1H101K	C CERA	50V B 100PF K (AXIAL)	
CA02	CCZB1H101K	C CERA	50V B 100PF K (AXIAL)	
CA03	CCZB1H101K	C CERA	50V B 100PF K (AXIAL)	
CA04	CCZB1H102K	C CERA	50V B 1000PF K (AXIAL)	
CA07	CCZB1H471K	C CERA	50V B 470PF K (AXIAL)	
CA08	CCZB1H471K	C CERA	50V B 470PF K (AXIAL)	
CA10	CCZB1H102K	C CERA	50V B 1000PF K (AXIAL)	
CA13	CCZB1H471K	C CERA	50V B 470PF K (AXIAL)	
CA14	CCZB1H471K	C CERA	50V B 470PF K (AXIAL)	
CA15	CCZB1H471K	C CERA	50V B 470PF K (AXIAL)	
CA16	CCZB1H471K	C CERA	50V B 470PF K (AXIAL)	
CA17	CCZB1H471K	C CERA	50V B 470PF K (AXIAL)	
CA18	CCZB1H471K	C CERA	50V B 470PF K (AXIAL)	
CA19	CCZB1H222K	C CERA	50V B 2200PF K (AXIAL)	
CA20	CCZB1H222K	C CERA	50V B 2200PF K (AXIAL)	
D100	DUZ33B----	DIODE ZENER	UZ-33B	
D101	DBA185----	DIODE	BAT185 (TAPPING)	
D103	DTSS851A--	DIODE	TSS851A	
D313	D1N4937G--	DIODE	1N4937G	
D360	DTZX22C---	DIODE ZENER	1ZX22C (TAPPING)	
D361	DUZ33B----	DIODE ZENER	UZ-33B	
D362	DUZ33B----	DIODE ZENER	UZ-33B	
D367	DUZ33B----	DIODE ZENER	UZ-33B	
D405	D1N4937G--	DIODE	1N4937G	
D407	DRGP15J---	DIODE	RGP15J	
D408	DRGP15J---	DIODE	RGP15J	
D410	D1N4004S--	DIODE	1N4004S	
D411	D1N4004S--	DIODE	1N4004S	
D450	D1N4937G--	DIODE	1N4937G	
D520	D1N4148---	DIODE	1N4148 (TAPPING)	

LOC	PART CODE	PART NAME	DESCRIPTION	REMARK
D521	D1N4148---	DIODE	1N4148 (TAPPING)	
D533	D1N4148---	DIODE	1N4148 (TAPPING)	
D534	D1N4148---	DIODE	1N4148 (TAPPING)	
D537	D1N4148---	DIODE	1N4148 (TAPPING)	
D550	D1N4148---	DIODE	1N4148 (TAPPING)	
D551	D1N4148---	DIODE	1N4148 (TAPPING)	
D591	DUZ2R7B---	DIODE ZENER	UZ-2.7B	
D597	D1N4148---	DIODE	1N4148 (TAPPING)	
D598	D1N4148---	DIODE	1N4148 (TAPPING)	
D599	DTZX5V6B--	DIODE ZENER	1ZX5V6B (TAPPING)	
D601	D1N4148---	DIODE	1N4148 (TAPPING)	
D602	D1N4148---	DIODE	1N4148 (TAPPING)	
D603	85801065GY	WIRE COPPER	AWG22 1/0.65 TIN COATING	
D801	DLT2A05G--	DIODE	LT2A05G	
D802	DLT2A05G--	DIODE	LT2A05G	
D803	DLT2A05G--	DIODE	LT2A05G	
D804	DLT2A05G--	DIODE	LT2A05G	
D805	D1N4937G--	DIODE	1N4937G	
D806	D1N4937G--	DIODE	1N4937G	
D808	D1N4937G--	DIODE	1N4937G	
D809	D1N4937G--	DIODE	1N4937G	
D811	DTZX6V2---	DIODE ZENER	1ZX6V2B (TAPPING)	
D821	DRGP15J---	DIODE	RGP15J	
D824	D1N4148---	DIODE	1N4148 (TAPPING)	
D825	D1N4148---	DIODE	1N4148 (TAPPING)	
D830	D1N4937G--	DIODE	1N4937G	
D831	D1N4937G--	DIODE	1N4937G	
D840	D1N4148---	DIODE	1N4148 (TAPPING)	
D841	D1N4148---	DIODE	1N4148 (TAPPING)	
D850	DUZ2R7B---	DIODE ZENER	UZ-2.7B	
D911	D1N4004S--	DIODE	1N4004S	
D912	D1N4004S--	DIODE	1N4004S	
D913	D1N4004S--	DIODE	1N4004S	
D997	DLT2A05G--	DIODE	LT2A05G	
DA03	DTZX5V1B--	DIODE ZENER	1ZX5V1B (TAPPING)	
DA06	DTZX5V6B--	DIODE ZENER	1ZX5V6B (TAPPING)	
DA07	DTZX5V1B--	DIODE ZENER	1ZX5V1B (TAPPING)	
DA08	DTZX5V6B--	DIODE ZENER	1ZX5V6B (TAPPING)	
DA09	DTZX5V6B--	DIODE ZENER	1ZX5V6B (TAPPING)	
DA10	DTZX5V6B--	DIODE ZENER	1ZX5V6B (TAPPING)	
DA11	DTZX5V6B--	DIODE ZENER	1ZX5V6B (TAPPING)	
DA15	DTZX5V6B--	DIODE ZENER	1ZX5V6B (TAPPING)	
DA16	DTZX5V6B--	DIODE ZENER	1ZX5V6B (TAPPING)	
DA20	DTZX5V6B--	DIODE ZENER	1ZX5V6B (TAPPING)	
DA27	DTZX5V6B--	DIODE ZENER	1ZX5V6B (TAPPING)	
DA32	DTZX5V6B--	DIODE ZENER	1ZX5V6B (TAPPING)	
J002	85801065GY	WIRE COPPER	AWG22 1/0.65 TIN COATING	
J003	85801065GY	WIRE COPPER	AWG22 1/0.65 TIN COATING	
J005	85801065GY	WIRE COPPER	AWG22 1/0.65 TIN COATING	
J006	85801065GY	WIRE COPPER	AWG22 1/0.65 TIN COATING	
J007	85801065GY	WIRE COPPER	AWG22 1/0.65 TIN COATING	
J008	85801065GY	WIRE COPPER	AWG22 1/0.65 TIN COATING	
J009	85801065GY	WIRE COPPER	AWG22 1/0.65 TIN COATING	
J013	85801065GY	WIRE COPPER	AWG22 1/0.65 TIN COATING	
J015	85801065GY	WIRE COPPER	AWG22 1/0.65 TIN COATING	
J016	85801065GY	WIRE COPPER	AWG22 1/0.65 TIN COATING	
J018	85801065GY	WIRE COPPER	AWG22 1/0.65 TIN COATING	
J019	85801065GY	WIRE COPPER	AWG22 1/0.65 TIN COATING	
J022	85801065GY	WIRE COPPER	AWG22 1/0.65 TIN COATING	
J023	85801065GY	WIRE COPPER	AWG22 1/0.65 TIN COATING	
J024	85801065GY	WIRE COPPER	AWG22 1/0.65 TIN COATING	
J025	85801065GY	WIRE COPPER	AWG22 1/0.65 TIN COATING	
J036	85801065GY	WIRE COPPER	AWG22 1/0.65 TIN COATING	
J038	85801065GY	WIRE COPPER	AWG22 1/0.65 TIN COATING	
J046	85801065GY	WIRE COPPER	AWG22 1/0.65 TIN COATING	
J047	85801065GY	WIRE COPPER	AWG22 1/0.65 TIN COATING	
J053	85801065GY	WIRE COPPER	AWG22 1/0.65 TIN COATING	
J054	85801065GY	WIRE COPPER	AWG22 1/0.65 TIN COATING	
J056	85801065GY	WIRE COPPER	AWG22 1/0.65 TIN COATING	
J057	85801065GY	WIRE COPPER	AWG22 1/0.65 TIN COATING	
J058	85801065GY	WIRE COPPER	AWG22 1/0.65 TIN COATING	
J061	85801065GY	WIRE COPPER	AWG22 1/0.65 TIN COATING	
J065	85801065GY	WIRE COPPER	AWG22 1/0.65 TIN COATING	
J070	85801065GY	WIRE COPPER	AWG22 1/0.65 TIN COATING	
J072	85801065GY	WIRE COPPER	AWG22 1/0.65 TIN COATING	
J073	85801065GY	WIRE COPPER	AWG22 1/0.65 TIN COATING	
J075	85801065GY	WIRE COPPER	AWG22 1/0.65 TIN COATING	
J076	85801065GY	WIRE COPPER	AWG22 1/0.65 TIN COATING	
J079	85801065GY	WIRE COPPER	AWG22 1/0.65 TIN COATING	
J080	85801065GY	WIRE COPPER	AWG22 1/0.65 TIN COATING	
J082	85801065GY	WIRE COPPER	AWG22 1/0.65 TIN COATING	
J088	85801065GY	WIRE COPPER	AWG22 1/0.65 TIN COATING	

Service manual WP 895/895F, CP885/885F, CP485F

LOC	PART CODE	PART NAME	DESCRIPTION	REMARK
J100	85801065GY	WIRE COPPER	AWG22 1/0.65 TIN COATING	
J101	85801065GY	WIRE COPPER	AWG22 1/0.65 TIN COATING	
J111	85801065GY	WIRE COPPER	AWG22 1/0.65 TIN COATING	
J112	85801065GY	WIRE COPPER	AWG22 1/0.65 TIN COATING	
J120	85801065GY	WIRE COPPER	AWG22 1/0.65 TIN COATING	
J123	85801065GY	WIRE COPPER	AWG22 1/0.65 TIN COATING	
J124	85801065GY	WIRE COPPER	AWG22 1/0.65 TIN COATING	
J153	85801065GY	WIRE COPPER	AWG22 1/0.65 TIN COATING	
J166	85801065GY	WIRE COPPER	AWG22 1/0.65 TIN COATING	
J201	85801065GY	WIRE COPPER	AWG22 1/0.65 TIN COATING	
J234	85801065GY	WIRE COPPER	AWG22 1/0.65 TIN COATING	
J826	85801065GY	WIRE COPPER	AWG22 1/0.65 TIN COATING	
J827	85801065GY	WIRE COPPER	AWG22 1/0.65 TIN COATING	
J828	85801065GY	WIRE COPPER	AWG22 1/0.65 TIN COATING	
J829	85801065GY	WIRE COPPER	AWG22 1/0.65 TIN COATING	
J833	85801065GY	WIRE COPPER	AWG22 1/0.65 TIN COATING	
J835	85801065GY	WIRE COPPER	AWG22 1/0.65 TIN COATING	
J836	85801065GY	WIRE COPPER	AWG22 1/0.65 TIN COATING	
J840	85801065GY	WIRE COPPER	AWG22 1/0.65 TIN COATING	
J841	85801065GY	WIRE COPPER	AWG22 1/0.65 TIN COATING	
J844	85801065GY	WIRE COPPER	AWG22 1/0.65 TIN COATING	
J845	85801065GY	WIRE COPPER	AWG22 1/0.65 TIN COATING	
J846	85801065GY	WIRE COPPER	AWG22 1/0.65 TIN COATING	
J853	85801065GY	WIRE COPPER	AWG22 1/0.65 TIN COATING	
J858	85801065GY	WIRE COPPER	AWG22 1/0.65 TIN COATING	
J859	85801065GY	WIRE COPPER	AWG22 1/0.65 TIN COATING	
J860	85801065GY	WIRE COPPER	AWG22 1/0.65 TIN COATING	
J865	85801065GY	WIRE COPPER	AWG22 1/0.65 TIN COATING	
J873	85801065GY	WIRE COPPER	AWG22 1/0.65 TIN COATING	
J874	85801065GY	WIRE COPPER	AWG22 1/0.65 TIN COATING	
J876	85801065GY	WIRE COPPER	AWG22 1/0.65 TIN COATING	
J878	85801065GY	WIRE COPPER	AWG22 1/0.65 TIN COATING	
J879	85801065GY	WIRE COPPER	AWG22 1/0.65 TIN COATING	
J880	85801065GY	WIRE COPPER	AWG22 1/0.65 TIN COATING	
J881	85801065GY	WIRE COPPER	AWG22 1/0.65 TIN COATING	
J883	85801065GY	WIRE COPPER	AWG22 1/0.65 TIN COATING	
J885	85801065GY	WIRE COPPER	AWG22 1/0.65 TIN COATING	
J887	85801065GY	WIRE COPPER	AWG22 1/0.65 TIN COATING	
J888	85801065GY	WIRE COPPER	AWG22 1/0.65 TIN COATING	
J889	85801065GY	WIRE COPPER	AWG22 1/0.65 TIN COATING	
J891	85801065GY	WIRE COPPER	AWG22 1/0.65 TIN COATING	
J896	85801065GY	WIRE COPPER	AWG22 1/0.65 TIN COATING	
J903	85801065GY	WIRE COPPER	AWG22 1/0.65 TIN COATING	
J909	85801065GY	WIRE COPPER	AWG22 1/0.65 TIN COATING	
J912	85801065GY	WIRE COPPER	AWG22 1/0.65 TIN COATING	
J914	85801065GY	WIRE COPPER	AWG22 1/0.65 TIN COATING	
J915	85801065GY	WIRE COPPER	AWG22 1/0.65 TIN COATING	
J916	85801065GY	WIRE COPPER	AWG22 1/0.65 TIN COATING	
J917	85801065GY	WIRE COPPER	AWG22 1/0.65 TIN COATING	
J918	85801065GY	WIRE COPPER	AWG22 1/0.65 TIN COATING	
J919	85801065GY	WIRE COPPER	AWG22 1/0.65 TIN COATING	
J920	85801065GY	WIRE COPPER	AWG22 1/0.65 TIN COATING	
L105	5CPZ479K02	COIL PEAKING	4.7UH 3.5MM K (LAL021B)	
L153	5CPZ120K02	COIL PEAKING	12UH 3.5MM K (LAL021B)	
L501	5CPZ479K02	COIL PEAKING	4.7UH 3.5MM K (LAL021B)	
L502	RD-AZ220J	R CARBON FILM	1/4 22 OHM J	
L503	5CPZ479K02	COIL PEAKING	4.7UH 3.5MM K (LAL021B)	
L504	5CPZ479K02	COIL PEAKING	4.7UH 3.5MM K (LAL021B)	
L601	5CPZ479K02	COIL PEAKING	4.7UH 3.5MM K (LAL021B)	
L602	5CPZ479K02	COIL PEAKING	4.7UH 3.5MM K (LAL021B)	
L605	5CPZ479K02	COIL PEAKING	4.7UH 3.5MM K (LAL021B)	
L650	5MC0000100	COIL BEAD	MD-5 (HC-3550)	
L801	5MC0000100	COIL BEAD	MD-5 (HC-3550)	
LA01	5CPZ100K04	COIL PEAKING	10UH 10.5MM K (LAL041B)	
LA02	5CPZ100K04	COIL PEAKING	10UH 10.5MM K (LAL041B)	
LA03	5CPZ100K04	COIL PEAKING	10UH 10.5MM K (LAL041B)	
LA04	5CPZ100K04	COIL PEAKING	10UH 10.5MM K (LAL041B)	
R101	RD-AZ222J	R CARBON FILM	1/6 2.2K OHM J	
R103	RD-AZ123J	R CARBON FILM	1/6 12K OHM J	
R104	RD-AZ104J	R CARBON FILM	1/6 100K OHM J	
R105	RD-AZ272J	R CARBON FILM	1/6 2.7K OHM J	
R106	RD-AZ561J	R CARBON FILM	1/6 560 OHM J	
R107	RD-AZ561J	R CARBON FILM	1/6 560 OHM J	
R110	RD-AZ682J	R CARBON FILM	1/6 6.8K OHM J	
R111	RD-AZ222J	R CARBON FILM	1/6 2.2K OHM J	
R116	RD-AZ682J	R CARBON FILM	1/6 6.8K OHM J	
R117	RD-AZ682J	R CARBON FILM	1/6 6.8K OHM J	
R118	RD-AZ151J	R CARBON FILM	1/6 150 OHM J	
R120	RD-AZ101J	R CARBON FILM	1/6 100 OHM J	
R131	RD-AZ472J	R CARBON FILM	1/6 4.7K OHM J	
R151	RD-AZ102J	R CARBON FILM	1/6 1K OHM J	
R152	RD-AZ271J	R CARBON FILM	1/6 270 OHM J	

LOC	PART CODE	PART NAME	DESCRIPTION	REMARK
R153	RD-AZ470J	R CARBON FILM	1/6 47 OHM J	
R154	RD-AZ470J	R CARBON FILM	1/6 47 OHM J	
R155	RD-AZ751J	R CARBON FILM	1/6 750 OHM J	
R160	RD-AZ472J	R CARBON FILM	1/6 4.7K OHM J	
R161	RD-AZ102J	R CARBON FILM	1/6 1K OHM J	
R162	RD-AZ153J	R CARBON FILM	1/6 15K OHM J	
R163	RD-AZ752J	R CARBON FILM	1/6 7.5K OHM J	
R164	RD-AZ752J	R CARBON FILM	1/6 7.5K OHM J	
R177	RD-AZ562J	R CARBON FILM	1/6 5.6K OHM J	
R190	RD-AZ221J	R CARBON FILM	1/6 220 OHM J	
R191	RD-AZ331J	R CARBON FILM	1/6 330 OHM J	
R301	RD-AZ472J	R CARBON FILM	1/4 4.7K OHM J	
R310	RD-AZ432J	R CARBON FILM	1/4 4.3K OHM J	
R311	RD-AZ432J	R CARBON FILM	1/4 4.3K OHM J	
R330	RD-AZ473J	R CARBON FILM	1/4 4.7K OHM J	
R331	RD-2Z201J	R CARBON FILM	1/2 200 OHM J	
R350	RD-4Z222J	R CARBON FILM	1/4 2.2K OHM J	
R351	RD-4Z222J	R CARBON FILM	1/4 2.2K OHM J	
R370	RD-4Z159J	R CARBON FILM	1/4 1.5 OHM J	
R394	RD-AZ272J	R CARBON FILM	1/6 2.7K OHM J	
R395	RD-AZ394J	R CARBON FILM	1/4 390K OHM J	
R396	RD-AZ272J	R CARBON FILM	1/6 2.7K OHM J	
R398	RD-2Z109J	R CARBON FILM	1/2 1 OHM J	
R401	RD-4Z272J	R CARBON FILM	1/4 2.7K OHM J	
R402	RD-4Z220J	R CARBON FILM	1/4 22 OHM J	
R404	RD-2Z399J	R CARBON FILM	1/2 3.9 OHM J	
R406	RD-2Z182J	R CARBON FILM	1/2 1.8K OHM J	
R420	RD-2Z152J	R CARBON FILM	1/2 1.5K OHM J	
R444	85801065GY	WIRE COPPER	AWG22 1/0.65 TIN COATING	
R490	RD-4Z101J	R CARBON FILM	1/4 100 OHM J	
R500	RD-AZ101J	R CARBON FILM	1/6 100 OHM J	
R501	RD-AZ101J	R CARBON FILM	1/6 100 OHM J	
R502	RD-AZ101J	R CARBON FILM	1/6 100 OHM J	
R503	RD-AZ101J	R CARBON FILM	1/6 100 OHM J	
R504	RD-AZ473J	R CARBON FILM	1/6 47K OHM J	
R506	RD-AZ223J	R CARBON FILM	1/6 22K OHM J	
R507	RD-AZ562J	R CARBON FILM	1/6 5.6K OHM J	
R508	RD-AZ562J	R CARBON FILM	1/6 5.6K OHM J	
R509	RD-AZ472J	R CARBON FILM	1/6 4.7K OHM J	
R511	RD-AZ133J	R CARBON FILM	1/6 13K OHM J	
R512	RN-4Z1502F	R METAL FILM	1/4 15K OHM F	
R513	85801065GY	WIRE COPPER	AWG22 1/0.65 TIN COATING	
R517	RD-AZ102J	R CARBON FILM	1/6 1K OHM J	
R518	RD-AZ102J	R CARBON FILM	1/6 1K OHM J	
R530	RD-AZ103J	R CARBON FILM	1/6 10K OHM J	
R532	RD-AZ223J	R CARBON FILM	1/6 22K OHM J	
R533	RD-AZ103J	R CARBON FILM	1/6 10K OHM J	
R535	RD-AZ201J	R CARBON FILM	1/6 200 OHM J	
R537	RD-AZ201J	R CARBON FILM	1/6 200 OHM J	
R541	RD-AZ122J	R CARBON FILM	1/6 1.2K OHM J	
R542	RD-AZ223J	R CARBON FILM	1/6 22K OHM J	
R543	RD-AZ271J	R CARBON FILM	1/6 270 OHM J	
R544	RD-AZ222J	R CARBON FILM	1/6 2.2K OHM J	
R548	RD-AZ103J	R CARBON FILM	1/6 10K OHM J	
R550	RD-AZ102J	R CARBON FILM	1/6 1K OHM J	
R555	RD-AZ102J	R CARBON FILM	1/6 1K OHM J	
R560	RD-AZ101J	R CARBON FILM	1/6 100 OHM J	
R561	RD-AZ101J	R CARBON FILM	1/6 100 OHM J	
R562	RD-AZ152J	R CARBON FILM	1/6 1.5K OHM J	
R563	RD-AZ152J	R CARBON FILM	1/6 1.5K OHM J	
R566	RD-AZ220J	R CARBON FILM	1/6 22 OHM J	
R568	RD-AZ102J	R CARBON FILM	1/6 1K OHM J	
R569	RD-AZ181J	R CARBON FILM	1/6 180 OHM J	
R570	RD-AZ271J	R CARBON FILM	1/6 270 OHM J	
R572	RD-AZ101J	R CARBON FILM	1/6 100 OHM J	
R573	RD-AZ101J	R CARBON FILM	1/6 100 OHM J	
R576	RD-AZ181J	R CARBON FILM	1/6 180 OHM J	
R577	RD-AZ181J	R CARBON FILM	1/6 180 OHM J	
R578	RD-AZ330J	R CARBON FILM	1/6 33 OHM J	
R579	RD-AZ330J	R CARBON FILM	1/6 33 OHM J	
R580	RD-AZ271J	R CARBON FILM	1/6 270 OHM J	
R582	RD-AZ101J	R CARBON FILM	1/6 100 OHM J	
R583	RD-AZ101J	R CARBON FILM	1/6 100 OHM J	
R586	RD-AZ271J	R CARBON FILM	1/6 270 OHM J	
R587	RD-AZ101J	R CARBON FILM	1/6 100 OHM J	
R588	RD-AZ101J	R CARBON FILM	1/6 100 OHM J	
R589	RD-AZ330J	R CARBON FILM	1/6 33 OHM J	
R591	RD-AZ431J	R CARBON FILM	1/6 430 OHM J	
R592	RD-AZ102J	R CARBON FILM	1/6 1K OHM J	
R593	RD-AZ104J	R CARBON FILM	1/6 100K OHM J	
R594	RD-AZ222J	R CARBON FILM	1/6 2.2K OHM J	
R595	RD-AZ682J	R CARBON FILM	1/6 6.8K OHM J	

Service manual WP 895/895F, CP885/885F, CP485F

LOC	PART CODE	PART NAME	DESCRIPTION	REMARK
R596	RD-AZ472J-	R CARBON FILM	1/6 4.7K OHM J	
R597	RN-4Z1502F	R METAL FILM	1/4 15K OHM F	
R598	RN-4Z1502F	R METAL FILM	1/4 15K OHM F	
R599	RD-AZ101J-	R CARBON FILM	1/6 100 OHM J	
R601	RD-AZ101J-	R CARBON FILM	1/6 100 OHM J	
R602	RD-AZ104J-	R CARBON FILM	1/6 100K OHM J	
R605	RD-AZ101J-	R CARBON FILM	1/6 100 OHM J	
R606	RD-AZ101J-	R CARBON FILM	1/6 100 OHM J	
R608	RD-2Z151J-	R CARBON FILM	1/2 150 OHM J	
R609	RD-2Z151J-	R CARBON FILM	1/2 150 OHM J	
R614	RD-AZ102J-	R CARBON FILM	1/6 1K OHM J	
R615	RD-AZ102J-	R CARBON FILM	1/6 1K OHM J	
R620	RD-AZ102J-	R CARBON FILM	1/6 1K OHM J	
R621	RD-AZ102J-	R CARBON FILM	1/6 1K OHM J	
R622	RD-AZ102J-	R CARBON FILM	1/6 1K OHM J	
R641	RD-AZ102J-	R CARBON FILM	1/6 1K OHM J	
R642	RD-AZ102J-	R CARBON FILM	1/6 1K OHM J	
R646	RD-AZ102J-	R CARBON FILM	1/6 1K OHM J	
R647	RD-AZ102J-	R CARBON FILM	1/6 1K OHM J	
R649	RD-AZ102J-	R CARBON FILM	1/6 1K OHM J	
R650	RD-AZ752J-	R CARBON FILM	1/6 7.5K OHM J	
R651	RD-AZ102J-	R CARBON FILM	1/6 1K OHM J	
R652	RD-AZ102J-	R CARBON FILM	1/6 1K OHM J	
R660	RD-AZ752J-	R CARBON FILM	1/6 7.5K OHM J	
R661	RD-AZ752J-	R CARBON FILM	1/6 7.5K OHM J	
R662	RD-AZ752J-	R CARBON FILM	1/6 7.5K OHM J	
R700	RD-2Z332J-	R CARBON FILM	1/2 3.3K OHM J	
R709	RD-AZ102J-	R CARBON FILM	1/6 1K OHM J	
R710	RD-AZ102J-	R CARBON FILM	1/6 1K OHM J	
R711	RD-AZ103J-	R CARBON FILM	1/6 10K OHM J	
R712	RD-AZ181J-	R CARBON FILM	1/6 180 OHM J	
R713	RD-AZ331J-	R CARBON FILM	1/6 330 OHM J	
R720	RD-AZ122J-	R CARBON FILM	1/6 1.2K OHM J	
R721	RD-AZ181J-	R CARBON FILM	1/6 180 OHM J	
R722	RD-AZ221J-	R CARBON FILM	1/6 220 OHM J	
R723	RD-AZ331J-	R CARBON FILM	1/6 330 OHM J	
R724	RD-AZ471J-	R CARBON FILM	1/6 470 OHM J	
R805	RD-2Z100J-	R CARBON FILM	1/2 10 OHM J	
R806	RD-2Z472J-	R CARBON FILM	1/2 4.7K OHM J	
R807	RD-2Z272J-	R CARBON FILM	1/2 2.7K OHM J	
R808	RD-2Z821J-	R CARBON FILM	1/2 820 OHM J	
R810	RD-4Z102J-	R CARBON FILM	1/4 1K OHM J	
R811	RC-2Z565KP	R CARBON COMP	1/2 5.6M OHM K	△
R817	RD-AZ473J-	R CARBON FILM	1/6 47K OHM J	
R820	RD-AZ102J-	R CARBON FILM	1/6 1K OHM J	
R821	RD-4Z102J-	R CARBON FILM	1/4 1K OHM J	
R823	RD-4Z682J-	R CARBON FILM	1/4 6.8K OHM J	

LOC	PART CODE	PART NAME	DESCRIPTION	REMARK
R829	RD-AZ103J-	R CARBON FILM	1/6 10K OHM J	
R830	RD-AZ332J-	R CARBON FILM	1/6 3.3K OHM J	
R841	RD-2Z470J-	R CARBON FILM	1/2 47 OHM J	
R851	RD-AZ391J-	R CARBON FILM	1/6 390 OHM J	
R852	RD-AZ102J-	R CARBON FILM	1/6 1K OHM J	
R855	RD-4Z335J-	R CARBON FILM	1/4 3.3M OHM J	
R870	RD-2Z222J-	R CARBON FILM	1/2 2.2K OHM J	
R901	RD-AZ221J-	R CARBON FILM	1/6 220 OHM J	
R902	RD-AZ221J-	R CARBON FILM	1/6 220 OHM J	
R903	RD-AZ221J-	R CARBON FILM	1/6 220 OHM J	
R910	RD-AZ101J-	R CARBON FILM	1/6 100 OHM J	
R911	RD-AZ101J-	R CARBON FILM	1/6 100 OHM J	
R912	RD-AZ101J-	R CARBON FILM	1/6 100 OHM J	
R913	RD-AZ101J-	R CARBON FILM	1/6 100 OHM J	
R921	RC-2Z102K-	R CARBON COMP	1/2 1K OHM K	
R922	RC-2Z102K-	R CARBON COMP	1/2 1K OHM K	
R923	RC-2Z102K-	R CARBON COMP	1/2 1K OHM K	
R983	RD-4Z472J-	R CARBON FILM	1/4 4.7K OHM J	
R996	RD-2Z105J-	R CARBON FILM	1/2 1M OHM J	
R997	RD-2Z102J-	R CARBON FILM	1/2 1K OHM J	
RA01	RD-AZ220J-	R CARBON FILM	1/6 220 OHM J	
RA02	RD-AZ101J-	R CARBON FILM	1/6 100 OHM J	
RA03	RD-AZ101J-	R CARBON FILM	1/6 100 OHM J	
RA04	RD-AZ101J-	R CARBON FILM	1/6 100 OHM J	
RA05	RD-AZ333J-	R CARBON FILM	1/6 33K OHM J	
RA06	RD-AZ750J-	R CARBON FILM	1/6 75 OHM J	
RA07	RD-AZ333J-	R CARBON FILM	1/6 33K OHM J	
RA08	RD-AZ750J-	R CARBON FILM	1/6 75 OHM J	
RA09	RD-AZ750J-	R CARBON FILM	1/6 75 OHM J	
RA10	RD-AZ101J-	R CARBON FILM	1/6 100 OHM J	
RA11	RD-AZ750J-	R CARBON FILM	1/6 75 OHM J	
RA12	RD-AZ750J-	R CARBON FILM	1/6 75 OHM J	
RA13	RD-AZ113J-	R CARBON FILM	1/6 11K OHM J	
RA14	RD-AZ750J-	R CARBON FILM	1/6 75 OHM J	
RA16	RD-AZ750J-	R CARBON FILM	1/6 75 OHM J	
RA19	RD-AZ750J-	R CARBON FILM	1/6 75 OHM J	
RA29	RD-AZ102J-	R CARBON FILM	1/6 1K OHM J	
RA32	RD-AZ680J-	R CARBON FILM	1/6 68 OHM J	
RA44	RD-AZ113J-	R CARBON FILM	1/6 11K OHM J	
RA90	RD-AZ220J-	R CARBON FILM	1/6 22 OHM J	
RA91	RD-AZ473J-	R CARBON FILM	1/6 47K OHM J	
RA92	RD-AZ223J-	R CARBON FILM	1/6 22K OHM J	
ZZ140	PTPKCPB21U7FS	PACKING AS	DTB-21U7ZF-S	
M641	6520010200	STAPLE PIN	#3417 ALL	
M801	GPBBW3U7022	BOX	DTB-21U7	
M811	4858100L00	PAD	21U7 EPS	
M821	4858219101	BAG LAMINATED	1300X1150 (U.K)	

7. Exploded View

7-1 DWX-28W5

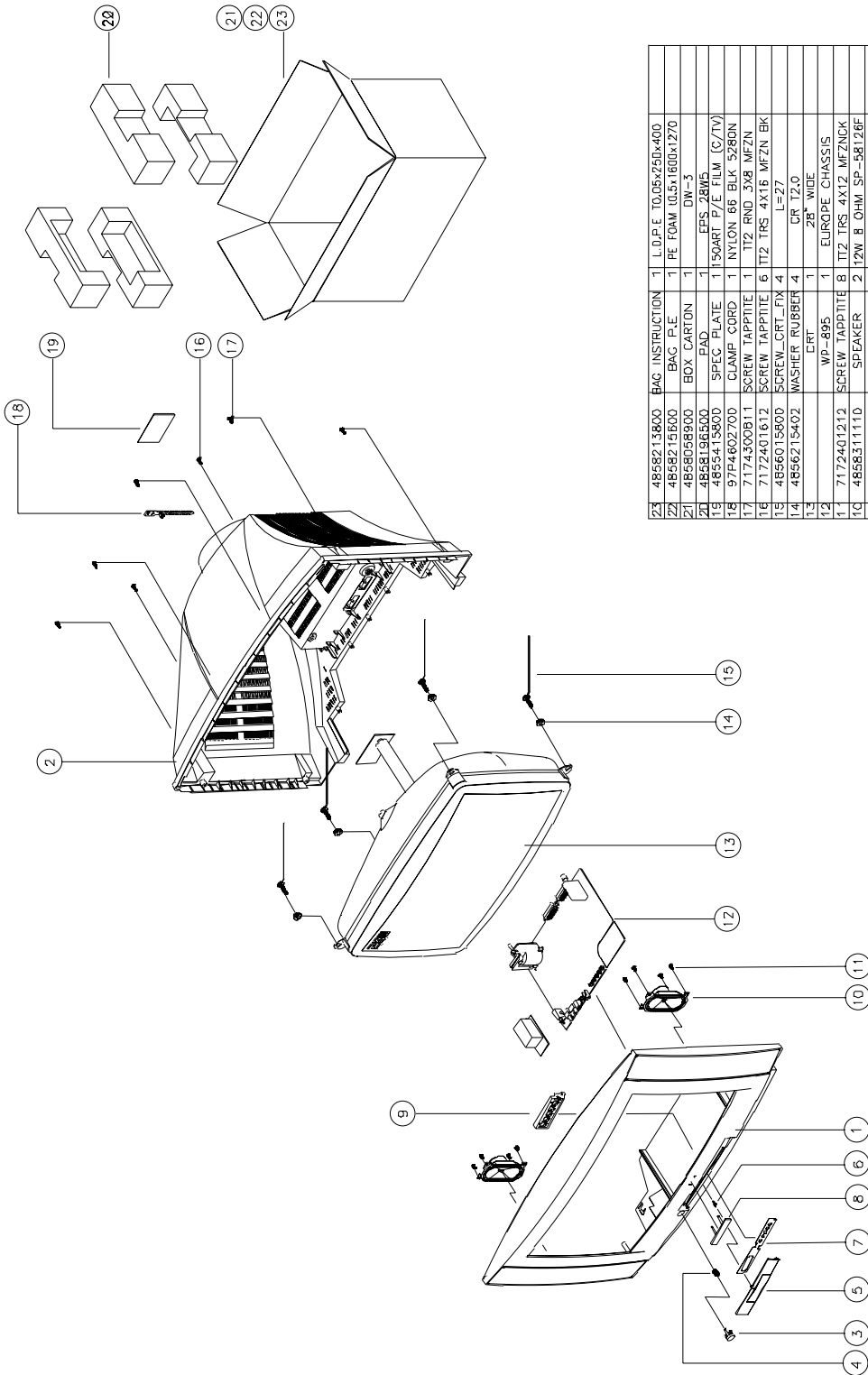

NO	PART CODE	PART NAME	QTY	MATERIAL	REMARKS
23	4856213800	BAG INSTRUCTION	1	L.D.P.E TO.05x750x400	
22	4856215800	BAG P.E	1	PE FOAM 10.5x1600x1270	
21	4856068900	BOX CARTON	1	DW-3	
20	4858196500	PAD	1	EPS 28W5	
19	4855415800	SPEC PLATE	1	150ART P/E FILM (C/TV)	
18	97P4602700	CLAMP CORD	1	NYLON 66 BLK 5280N	
17	7174300811	SCREW TAPPTITE	1	T12 RND 3X8 MFZN	
16	7172401612	SCREW TAPPTITE	6	T12 TRS 4X16 MFZN BK L=27	
15	4856015800	SCREW_CRT_FIX	4	CR T2.0	
14	4856215402	WASHER RUBBER	4	CR T2.0	
13		CRT	1	28" WIDE	
12		WP-895	1	EUROPE CHASSIS	
11	7172401212	SCREW TAPPTITE	8	T12 TRS 4X12 MFZNCK	
10	4856311110	SPEAKER	2	12W R OHM SP-58126F	
9	4854934001	BUTTON	1	ABS BK	
8	4855617401	MARK BRAND	1	AL (SILVER)	
7	4855059901	DECO CTRL	1	PVC T0.25	
6	4857923300	DOOR LOCK	1	LA701(K1F00)	
5	4852822601	DOOR	1	PC GY	
4	4856716000	SPRING	1	SWPA P1E0.5	
3	4854859511	BUTTON POWER	1	HIPS GY	
2	4852158911	COVER BACK	1	HIPS GY	
1	4852077111	MASK FRONT	1	HIPS GY	
NC					

7. Exploded View

7-2 DWF-28W8

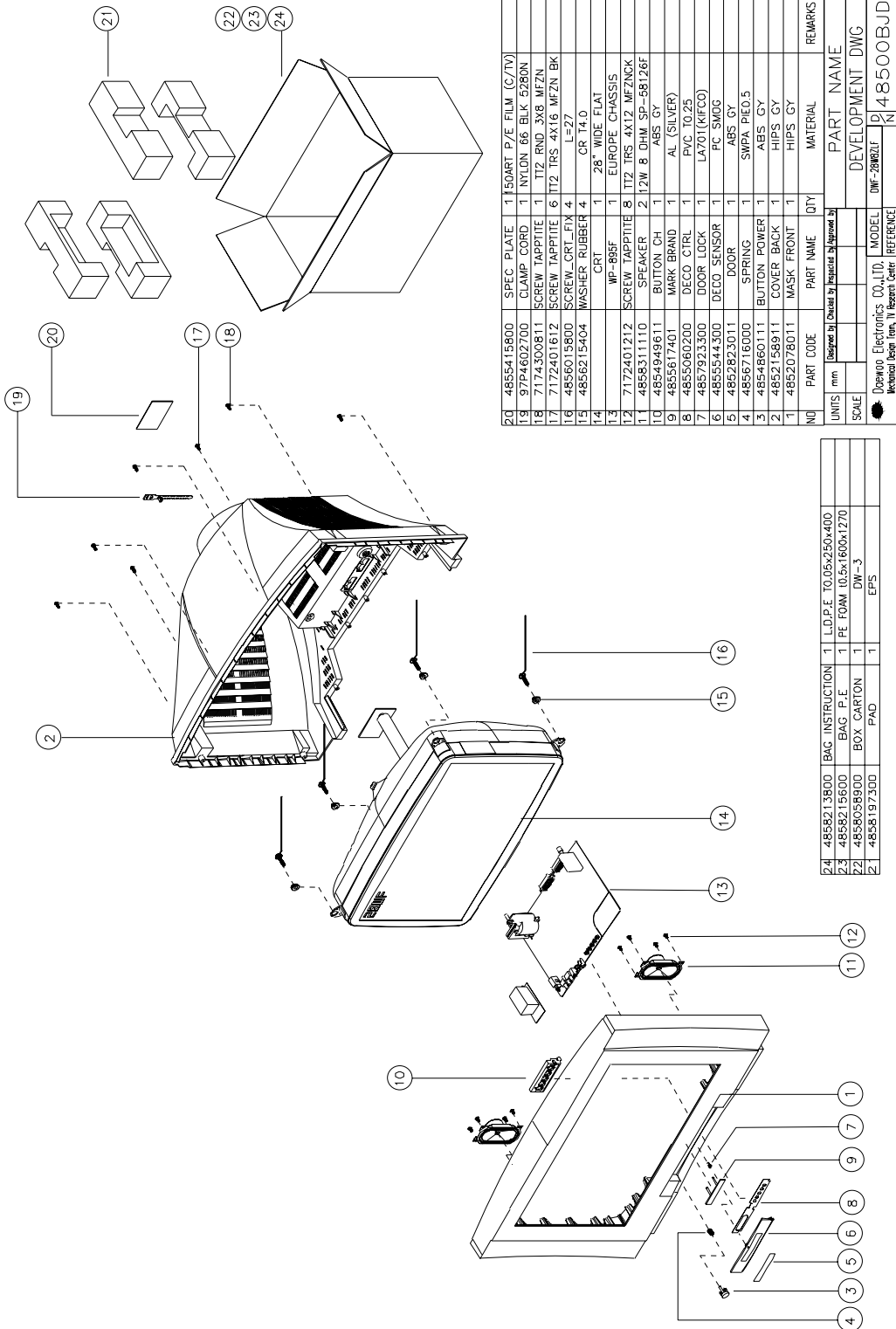

NO	PART CODE	PART NAME	QTY	MATERIAL	REMARKS
20	4855415800	SPEC PLATE	1	ISOART P/E FILM (C/TV)	
19	97P4602700	CLAMP CORD	1	NYLON 66 BLK 5280N	
18	7174300811	SCREW TAPPTITE	1	TT2 RND 3X8 MFXN	
17	7172401612	SCREW TAPPTITE	6	TT2 TRS 4X16 MFXN BK L=27	
16	4856015800	SCREW_CRT_FIX	4	CR T4.0	
15	4856215404	WASHER RUBBER	4	CR T4.0	
14		CRT	1	28" WIDE FLAT	
13	WP-895F	WP-895F	1	EUROPE CHASSIS	
12	7172401212	SCREW TAPPTITE	8	TT2 TRS 4X12 MFXNCK	
11	4858311110	SPEAKER	2	12W 8 OHM SP-58126F ABS GY	
10	4854949611	BUTTON CH	1	AL (SILVER)	
9	4855617401	MARK BRAND	1	PVC T0.25	
8	4855060200	DECO CTRN	1	LA701(KIFCC)	
7	4857923300	DOOR LOCK	1	PC SMOG	
6	4855544300	DECO SENSOR	1	ABS GY	
5	4852823011	DOOR	1	ABS GY	
4	4856716000	SPRING	1	SWPA PEO.5	
3	4854860111	BUTTON POWER	1	ABS GY	
2	4852158911	COVER BACK	1	HIPS GY	
1	4852078011	MASK FRONT	1	HIPS GY	

UNITS	mm	mm	mm
SCALE			
24	4858213800	BAG INSTRUCTION	1
23	4858215600	BAG P.E	1
22	4858058900	BOX CARTON	1
21	4858197300	PAD	1

UNITS	mm	mm	mm
SCALE			
DESIGNED BY	Checked by	Inspected by	Approved by
PART NAME			
DEVELOPMENT DWG			
DOMINO Electronics CO., LTD.	MODEL	DWF-28W8ZLF	P 48500BJD
Revised Design Team, IT Resident Center	REFERENCE		N

7. Exploded View

7-3 DTF-29U8

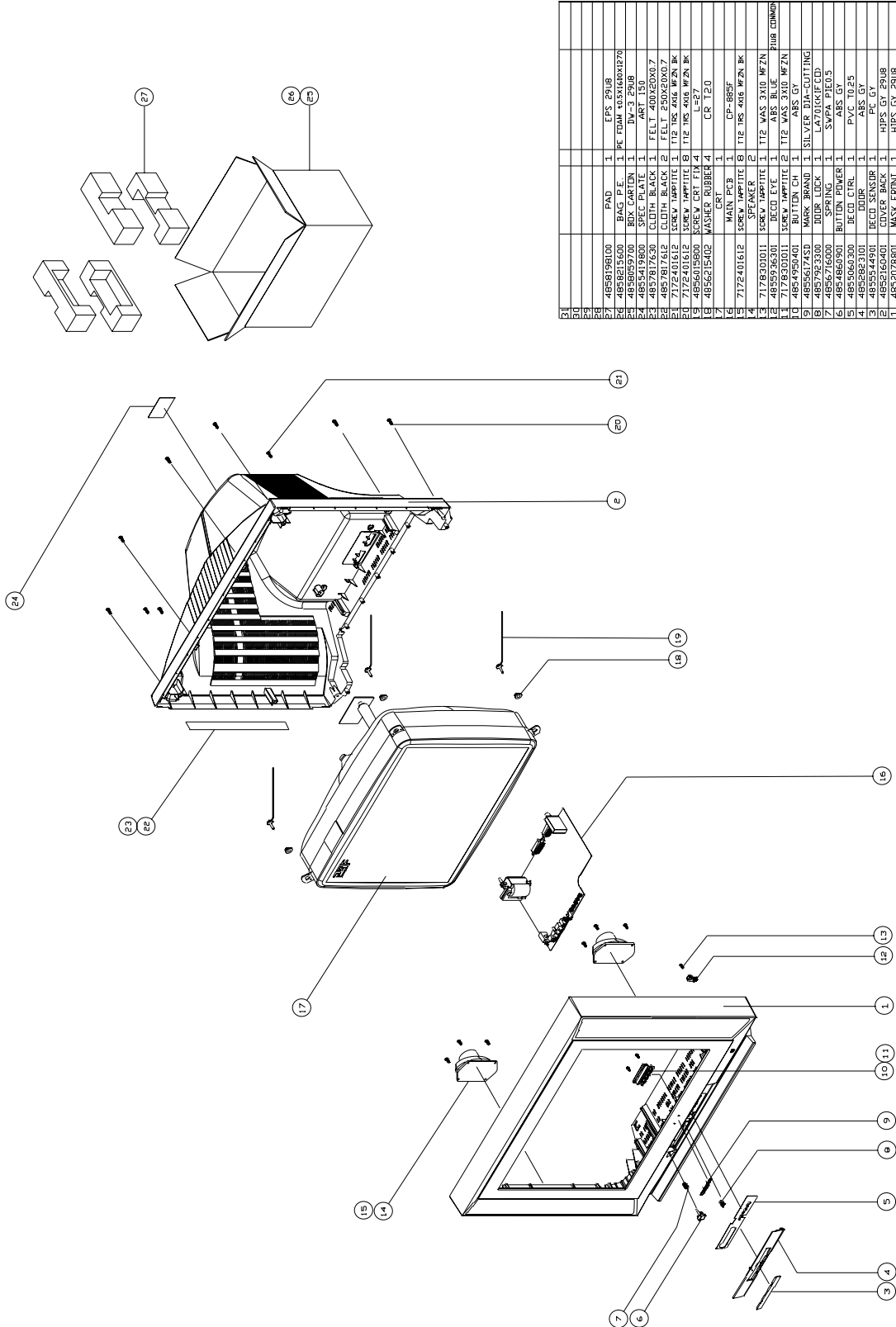

7. Exploded View

7-4 DTP-28A7

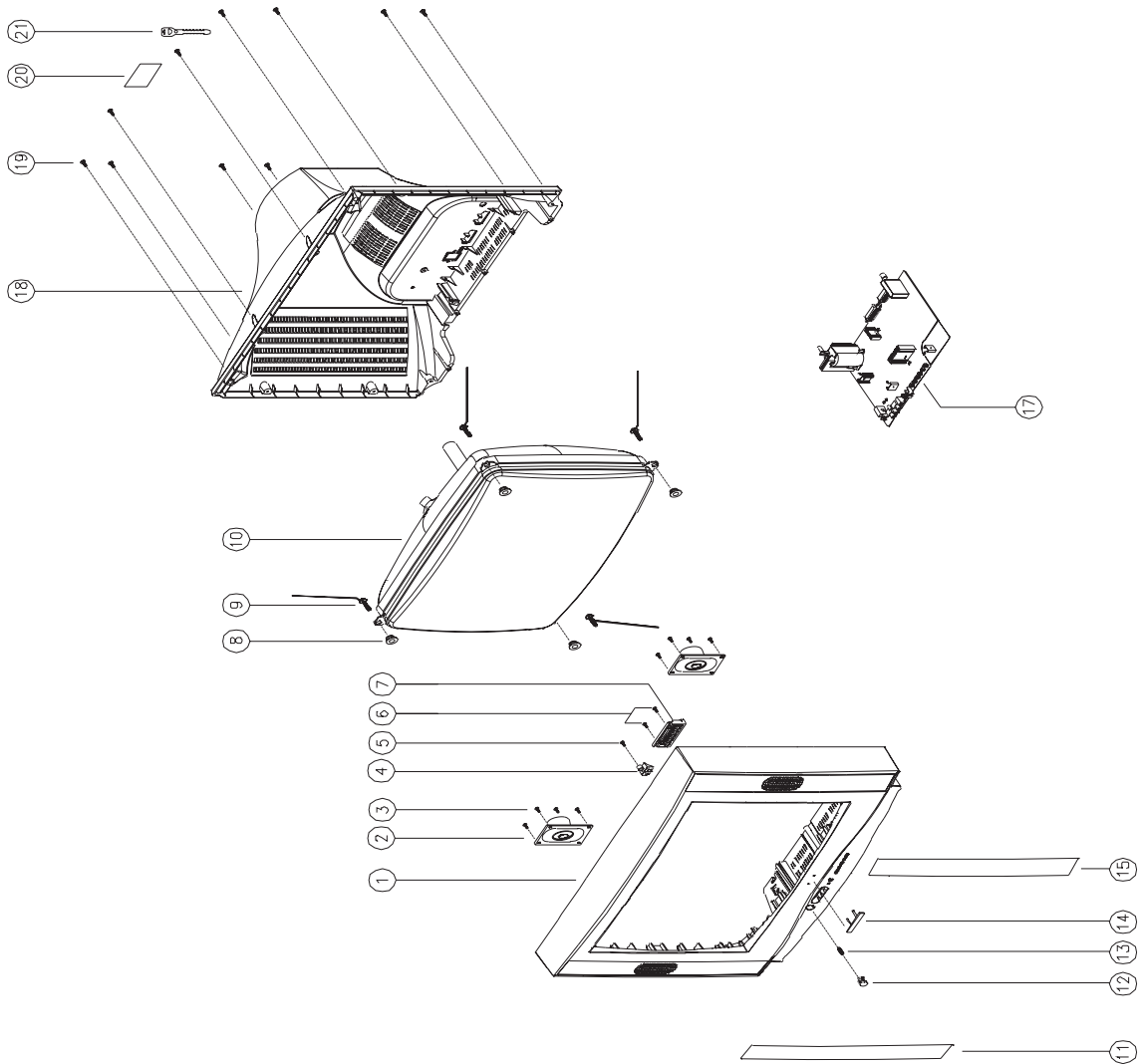

No.	PART CODE	PART NAME	QTY	MATERIAL	REMARKS
21	19794602700	CLAMP CORD	1	INLDN 66 BK 528MM	
20	4855415800	SPEC PLATE	1	150ART P/E FLW(G/TV)	
19	7172401612	SCREW TAPPITE	10	IT2 TRS 4X16 W/ZN BK	1+3
18	4852157001	COVER BACK	1	HIPS GY	17+30
17		CHASSIS	1	GP-885	
16	485353600	HOLDER LED	1	GP-BK	
15	4852441000	GRILL SPKR R	1	PS	
14	4855617401	MARK BRAND	1	AL(SILVER)	
13	4856716000	SPRING	1	SWPA PE 0.5	
12	4854857201	BUTTON POWER	1	ABS GY	
11	4852540900	GRILL SPKR L	1	PS	
10		CRT	1	PHILIPS 28"	
9	4856015820	SCREW CRT FIX	4	SWRMA-SK5 L=35	1+10
8	4856215402	WASHER RUBBER	4	CR T2.0	
7	4854946601	BUTTON CH	1	ABS GY	
6	7129301011	SCREW TAPPING	2	T2S WAS 3X10 W/ZN	1+7
5	7129301011	SCREW TAPPING	1	T2S WAS 3X10 W/ZN	1+4
4	4855541700	DECO SENSOR	1	PMMA	
3	7172401212	SCREW TAPPITE	8	IT2 TRS 4X12 W/ZNCK	1+2
2	4856311110	SPEAKER	2	17W 8 OHM SP-58126	
1	4852075001	MASK FRONT	1	HIPS GY	
		PART NAME			
		REMARKS			

7. Exploded View

7-5 DTP-28B1

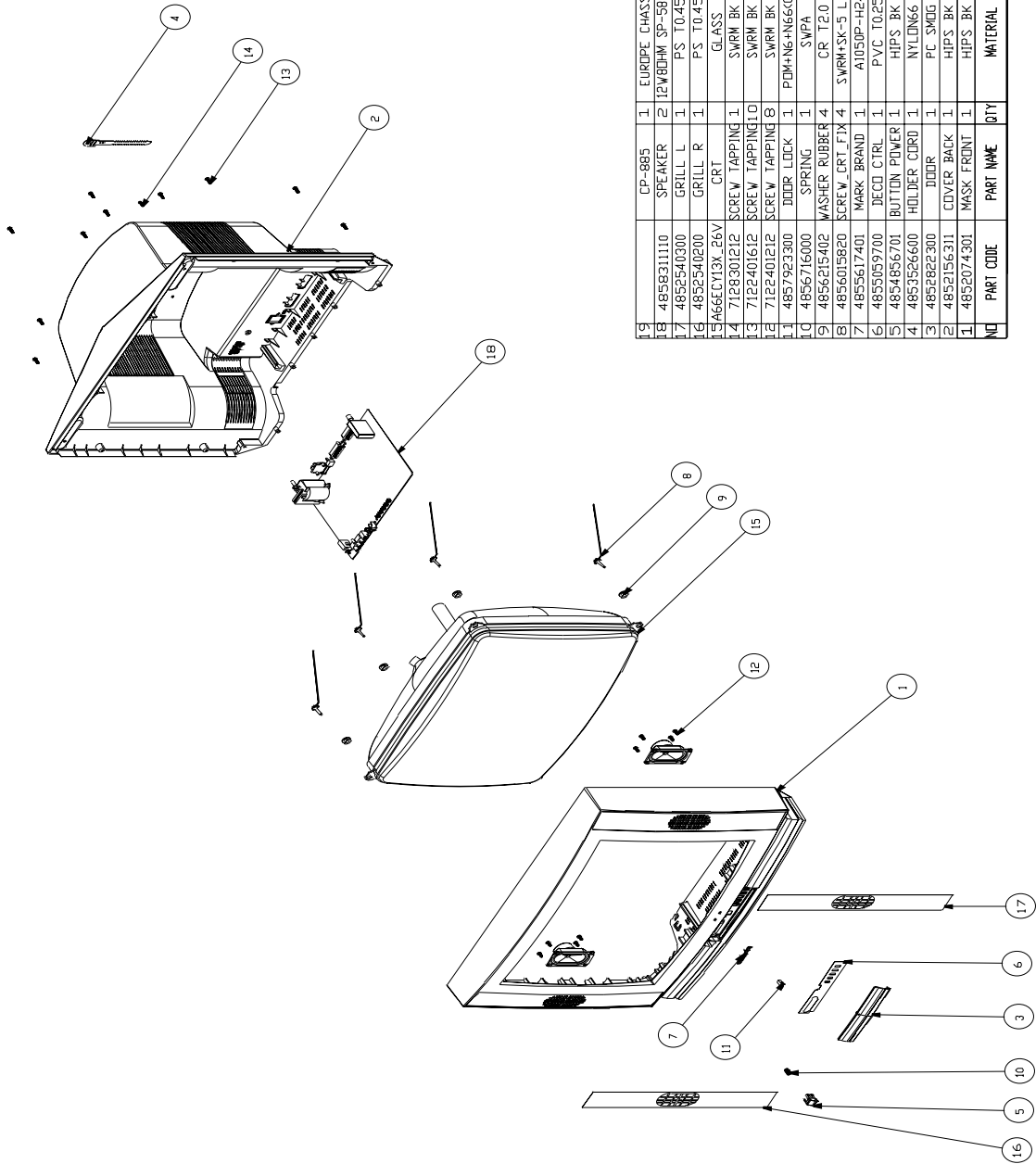

NO	PART CODE	PART NAME	QTY	MATERIAL	REMARKS
19	CP-895	EUROPE CHASSIS	1		
18	485831110	SPEAKER	2	12W80HM SP-58126F	
17	4852540300	GRILL L	1	PS TO.45	
16	4852540200	GRILL R	1	PS TO.45	
15	A66ECY13X.26V	GRT		GLASS	
14	7128301212	SCREW TAPPING	1	SWRM BK	
13	7122401612	SCREW TAPPING	10	SWRM BK	
12	7122401212	SCREW TAPPING	8	SWRM BK	
11	4857923300	DOOR LOCK	1	PDM+N6+NG6G30	
10	4856716000	SPRING	1	SWPA	
9	4856215402	WASHER RUBBER	4	CR T2.0	
8	4856015820	SCREW CRT FIX	4	SWRM+SK-5 L=35	
7	4855617401	MARK BRAND	1	A1050P-H24	
6	4855059700	DECD CTRL	1	PVC TO.25	
5	4854856701	BUTTON POWER	1	HIPS BK	
4	4853526600	HOLDER CORD	1	NYLON66	
3	4852822300	DOOR	1	PL SMOG	
2	4852156311	COVER BACK	1	HIPS BK	
1	4852074301	MASK FRONT	1	HIPS BK	
NO	PART CODE	PART NAME	QTY	MATERIAL	REMARKS

7. Exploded View

7-6 DTP-28G7

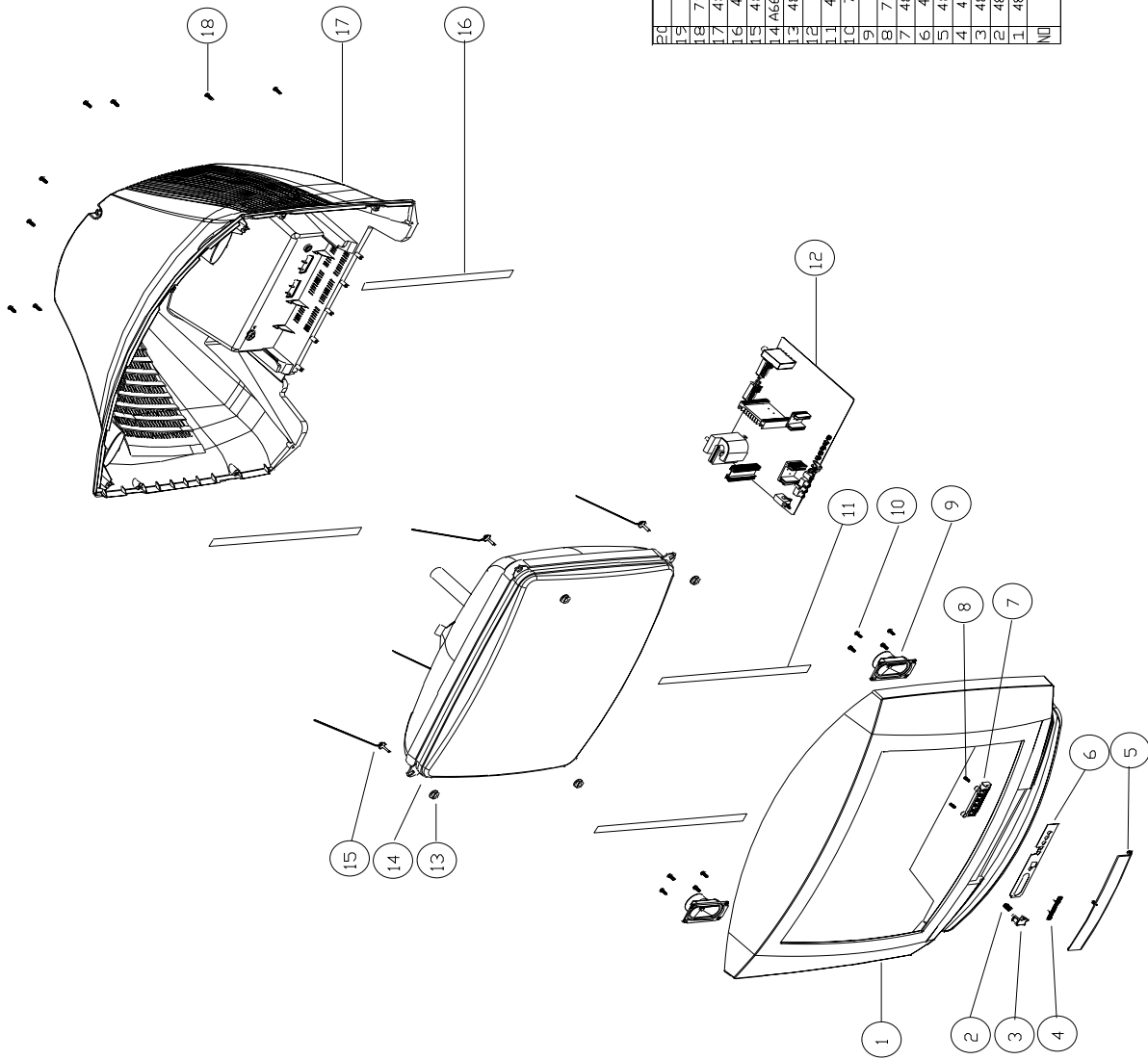

NO	PART CODE	PART NAME	QTY	MATERIAL	REMARKS
1	7122401612	SCREW TAPPING	10	SWRM BK	
2	4852151900	COVER BACK	1	HIPS BK	
3	4857817611	CLOTH BLACK	2	FELT 10.7 L=200	
4	48564015800	SCREW CRT_FIX	4	SWRM+SK-5 BK	
5	4666CY13X_26V	CRT Assy	1	GLASS	
6	4856215402	WASHER RUBBER	4	CR	
7	4857818702	CLOTH BLACK	2	FELT 10.7 L=250 W=15	
8	7122401412	SCREW TAPPING	8	SWRM BK	
9	7121301212	SPEAKER	2	SWRM BK	
10	4854939901	BUTTON CTRL	1	ABS BK	
11	4855059901	DECD_CTRL	1	PS	
12	4852821501	DOOR	1	PC	
13	4855617400	MARK BRAND	1	A1050P-H24	
14	4854854001	BUTTON_POWER	1	ABS	
15	4856716001	SPRING	1	SWPA	
16	4852067901	MASK FRONT	1	HIPS BK	
17					
18					

7. Exploded View

7-7 DTP-28G8

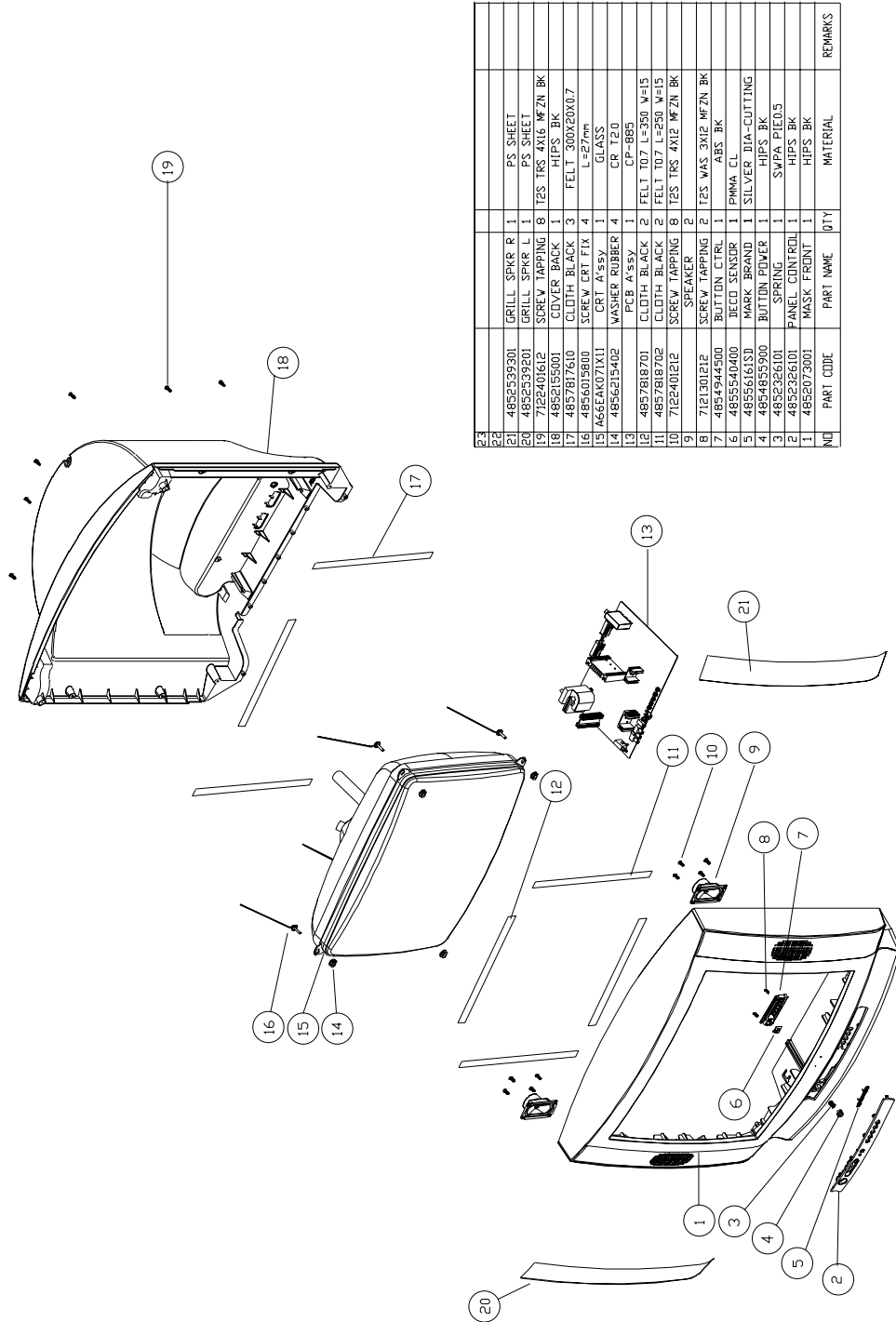

NO	PART CODE	PART NAME	QTY	MATERIAL	REMARKS
53					
54					
55					
56	485233201	GRILL SPKR R	1	PS SHEET	
57	485233201	GRILL SPKR L	1	PS SHEET	
58	71224012E	SCREW TAPPING Ø	2	TSS TRS AXI2 WF7N BK	
59	485215500	COVER BACK	1	HIPS BK	
60	4857817610	CLOTH BLACK	3	FELT 300X20X0.7	
61	4856015800	SCREW CRT FIX	4	L=27mm	
62	A64AK071X1	SCRIT A-25V	1	GLASS	
63	4856215402	WASHER RUBBER	4	CP T20	
64	4857818701	CLOTH BLACK	2	CP-885	
65	4857818702	CLOTH BLACK	2	FELT 107 L=250 W=15	
66	71224012E	SCREW TAPPING Ø	2	FELT 107 L=250 W=15	
67	71213012E	SPEAKER	2	TSS TRS AXI2 WF7N BK	
68	71213012E	SCREW TAPPING Ø	2	TSS TRS AXI2 WF7N BK	
69	4854944500	BUTTON CTRL	1	ABS BK	
70	485540400	DECID SENSOR	1	PMMA CL	
71	485215500	MARK BRAND	1	SILVER DIA-CUTTING	
72	4854956200	BUTTON POWER	1	HIPS BK	
73	4852324101	SPRING	1	SVBA P10.5	
74	4852324101	PANEL CONTROL	1	HIPS BK	
75	4852073001	MASK FRONT	1	HIPS BK	
76					

7. Exploded View

7-8. DWF-28W9

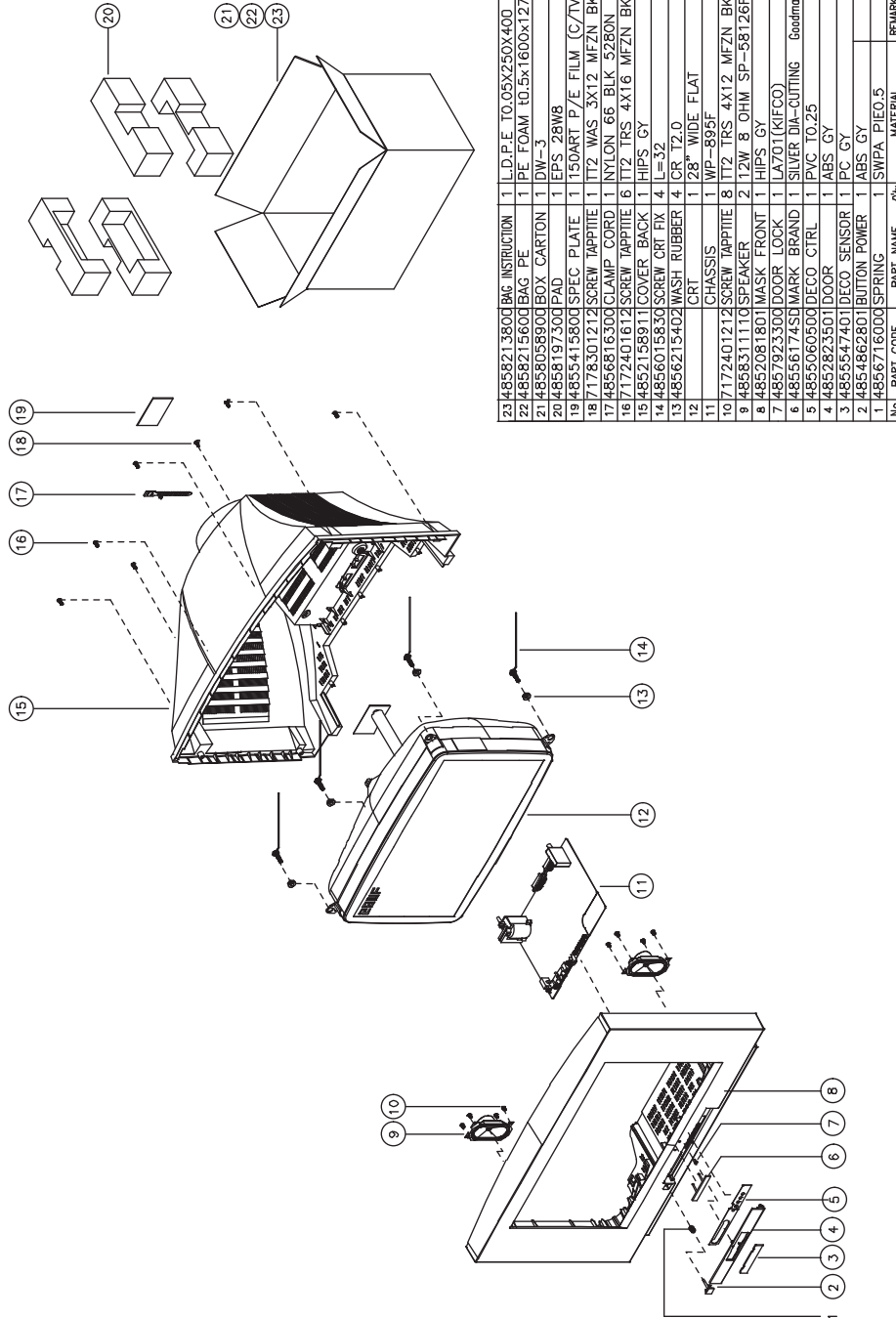

No	PART CODE	PART NAME	Q'ty	MATERIAL	REMARKS
23	H4858213800	BAG INSTRUCTION	1	L.D.P.E T0.05X250X400	
22	H4858215600	BAG PE	1	PE FOAM t0.5x1600x1270	
21	H4858036900	BOX CARTON	1	DW-3	
20	H4858197300	PAD	1	EPS 28W8	
19	H4855415800	SPEC PLATE	1	150ART P/E FILM (C/TV)	
18	H7178301212	SCREW TAPPTIE	1	TT2 WAS 3X12 MFZN BK	
17	H4856816300	CLAMP CORD	1	NYLON .66 BLK 52E0N	
16	H7172401612	SCREW TAPPTIE	6	TT2 TRS 4X16 MFZN BK	
15	H4852158911	COVER BACK	1	HIPS GY	
14	H4856015830	SCREW CRT FX	4	L=32	
13	H4856215402	WASH RUBBER	4	CR T2.0	
12		CRT	1	28" WIDE FLAT	
11		CHASSIS	1	WP-895F	
10	H7172401212	SCREW TAPPTIE	8	TT2 TRS 4X12 MFZN BK	
9	H4858311110	SPEAKER	2	12W 8 OHM SP-58126F	
8	H485081801	MASK FRONT	1	HIPS GY	
7	H4857923300	DOOR LOCK	1	LA701(KIFCO)	
6	H4856617450	MARK BRAND	1	SILVER DIA-CUTTING Goodmans	
5	H4855060900	DECO CTRL	1	PVC T0.25	
4	H4852823501	DOOR	1	ABS GY	
3	H4855547401	DECO SENSOR	1	PC GY	
2	H4854862801	BUTTON POWER	1	ABS GY	
1	H4856716000	SPRING	1	SWPA P1EO.5	

7. Exploded view

7-9 DTB-21U7

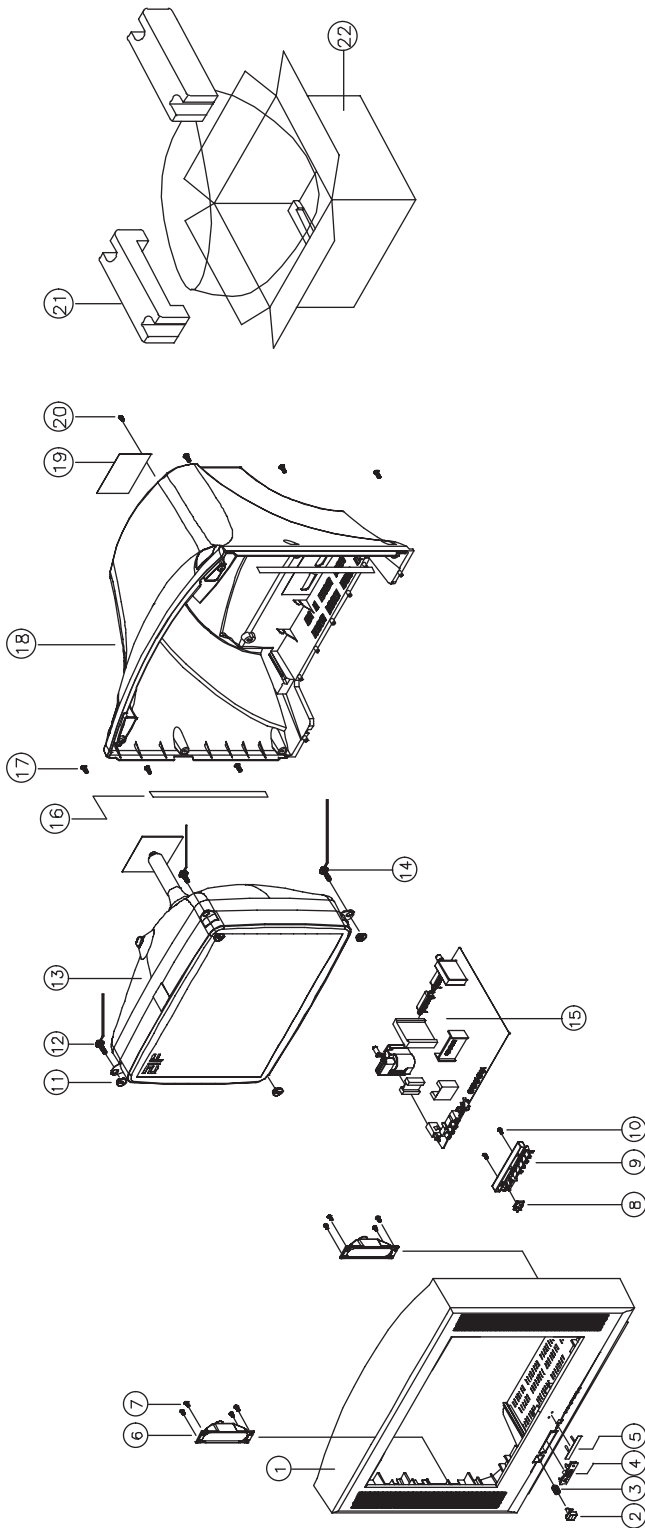

NO	PART CODE	PART NAME	QTY	MATERIAL	REMARKS	NO	PART CODE	PART NAME	QTY	MATERIAL	REMARKS
25		MAIN PCB	1			15		MAIN PCB	1		
14	4856013302	SCREW CRT FIXING AS	2	30X190 BK		13		SCREW CRT FIXING AS	2	30X190 BK	
13		CRT (21" FLAT)	1			12		SCREW CRT FIXING AS	2	30X80 BK	
12	4856013300	SCREW CRT FIXING AS	2	30X80 BK		11		WASHER RUBBER	4	CR T2.0 BLACK	
11	4856219502	WASHER RUBBER	4	CR T2.0 BLACK		10		SCREW TAPPING	2	T2S WAS 3X10 MFZN	
10	7128301011	SCREW TAPPING	2	T2S WAS 3X10 MFZN		9		SCREW TAPPING	2	T2S WAS 3X10 MFZN	
9	4854952901	SCREW TAPPING	2	T2S WAS 3X10 MFZN		8		DECORATIVE SENSOR	1	PANNA MILKY	
8	4855547601	DECORATIVE SENSOR	1	PANNA MILKY		7		SCREW TAPPING	8	T2S WAS 3X10 MFZN	
7	7128301011	SCREW TAPPING	8	T2S WAS 3X10 MFZN		6		SPEAKER	2	SP-35129A03	
6	4856314910	SPEAKER	2	SP-35129A03		5		MARK BRAND	1	AT060P-H24 T0.4	
5	4855617500	MARK BRAND	1	AT060P-H24 T0.4		4		COVER JACK	1	ABS GY	
4	4857539601	COVER JACK	1	ABS GY		3		SPRING	1	SWPA PIE T0.5	
3	4856716000	SPRING	1	SWPA PIE T0.5		2		SCREW TAPPING	6	T2S TRS 4X14 MFZN BK	
2	4854862501	SCREW TAPPING	6	T2S TRS 4X14 MFZN BK		1		SCREW TAPPING	2	FELT 300X200X0.7	
1	4852081201	SCREW TAPPING	2	FELT 300X200X0.7				MASK FRONT	1	ABS GY	
NO	PART CODE	PART NAME	QTY	MATERIAL	REMARKS	NO	PART CODE	PART NAME	QTY	MATERIAL	REMARKS
26		BOX CARTON	1	DW-3		24		SCREW CRT FIXING AS	2	30X190 BK	
27	4858059100	BOX CARTON	1	DW-3		23		CRT (21" FLAT)	1		
28	4858100100	PAD	1	EPS 21U7		22		SCREW CRT FIXING AS	2	30X80 BK	
29	7128301211	SCREW TAPPING	1	T2S WAS 3X12 MFZN		21		WASHER RUBBER	4	CR T2.0 BLACK	
30	4855415800	SPEC PLATE	1	150 ART F/E FILM(C/V)		20		SCREW TAPPING	2	T2S WAS 3X10 MFZN	
31	4852161901	COVER BACK	1	HIPS GY		19		SCREW TAPPING	2	T2S WAS 3X10 MFZN	
32	7122401412	SCREW TAPPING	6	T2S TRS 4X14 MFZN BK		18		SCREW TAPPING	6	T2S TRS 4X14 MFZN BK	
33	4857817610	CLOTH BLACK	2	FELT 300X200X0.7		17		SCREW TAPPING	2	FELT 300X200X0.7	

SCHEMATIC DIAGRAM(WP-895 / CP-885)

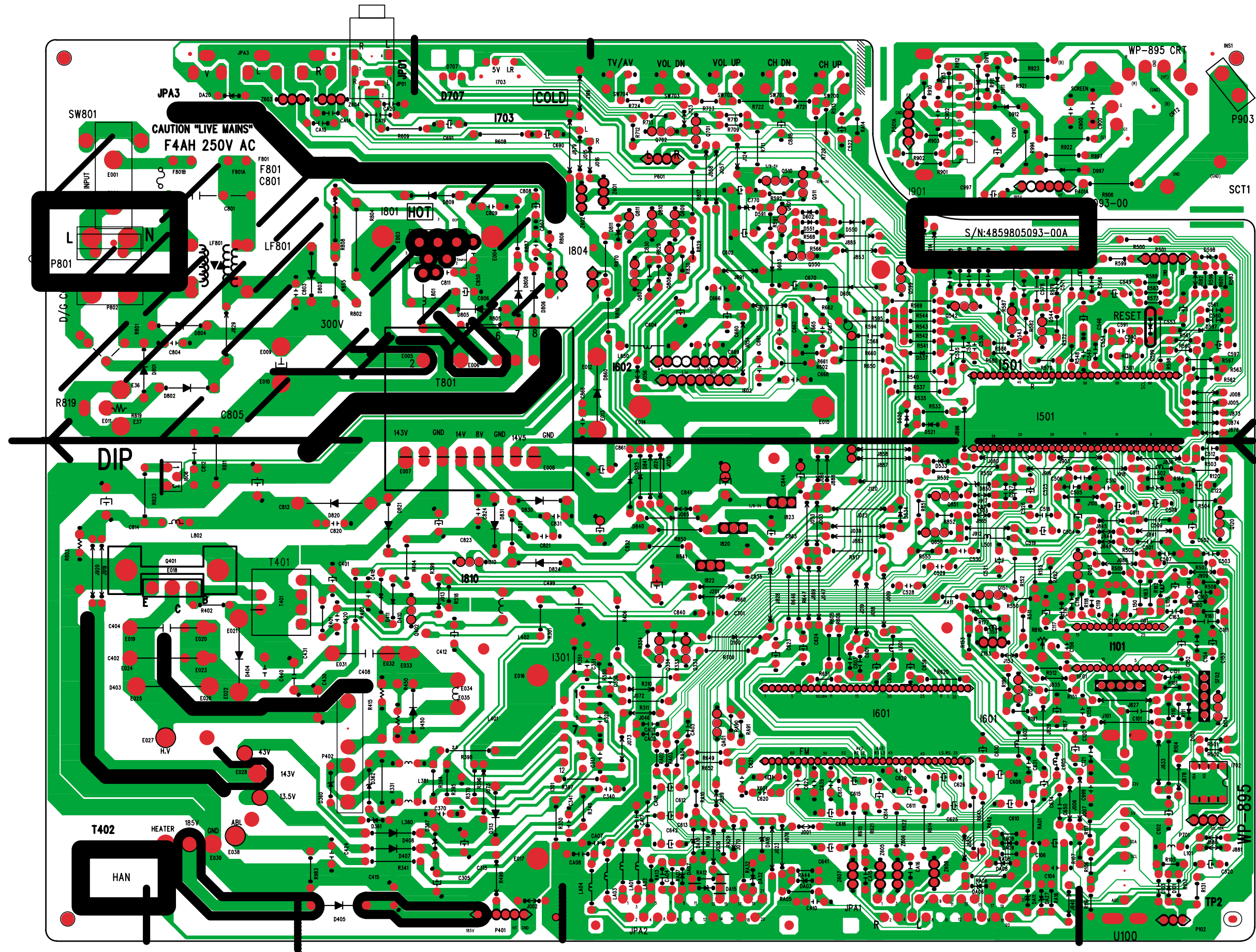

SCHEMATIC DIAGRAM(WP-895F / CP-885F)

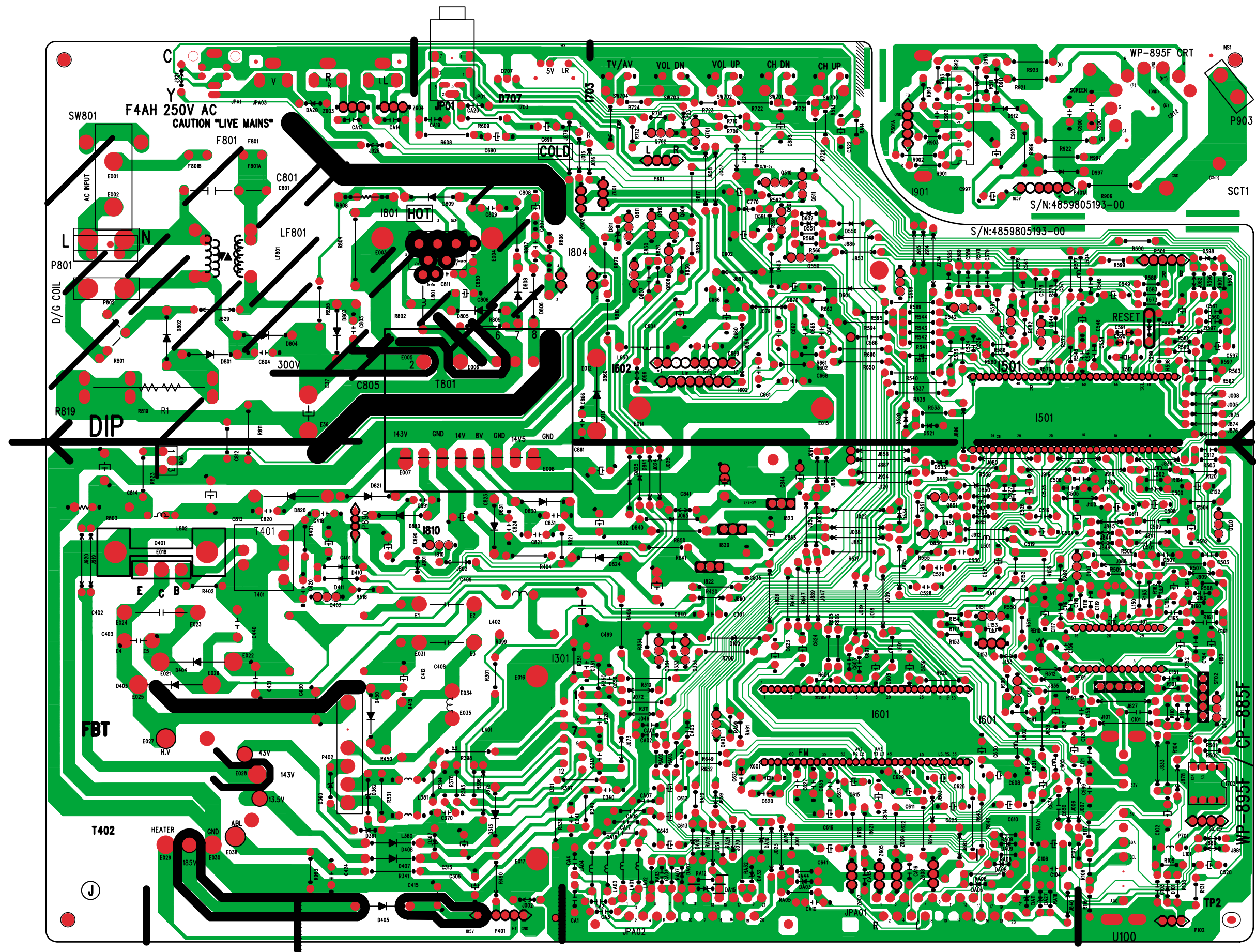

SCHEMATIC DIAGRAM(CP-485F)

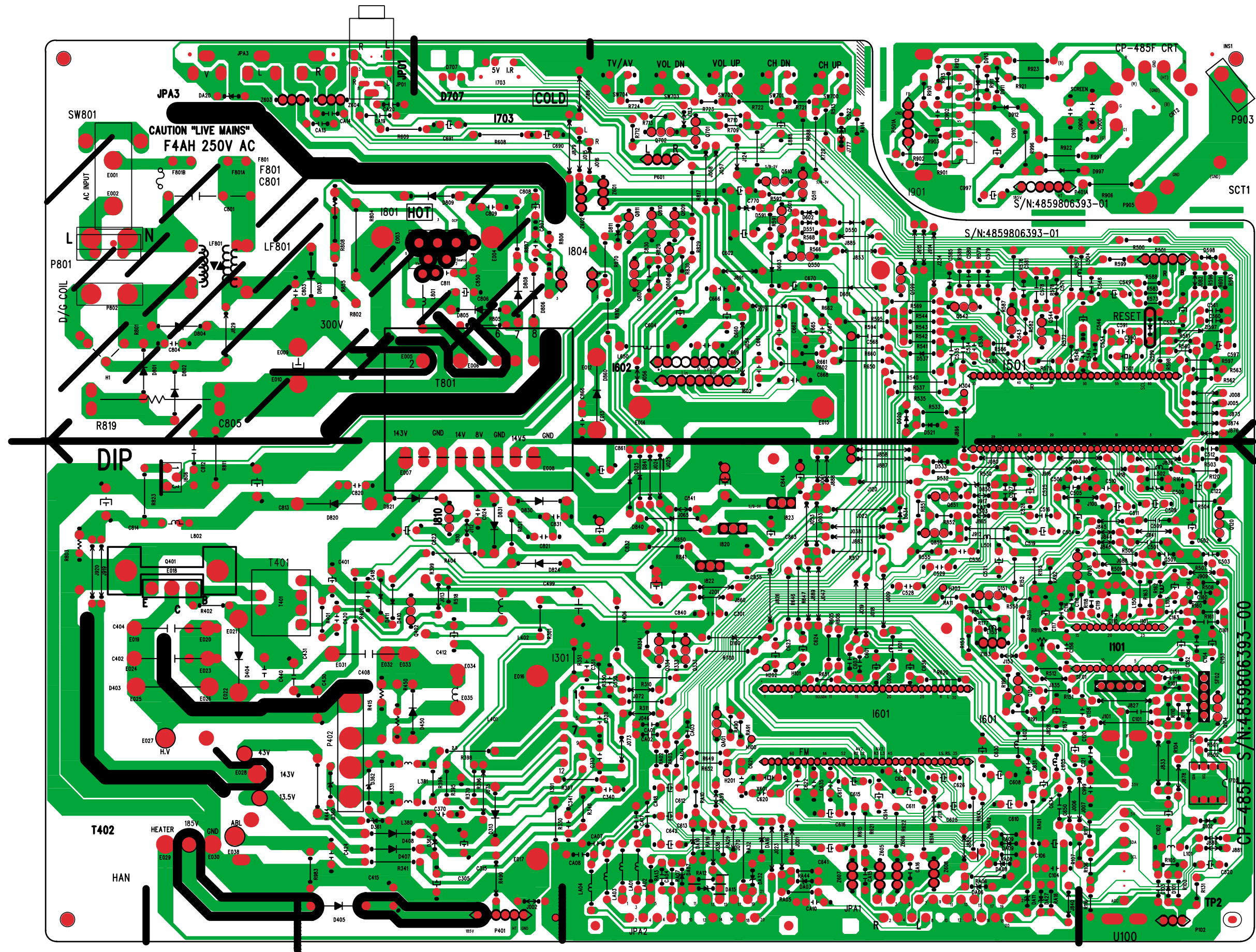

SCHEMATIC DIAGRAM (WP-895 / CP885)

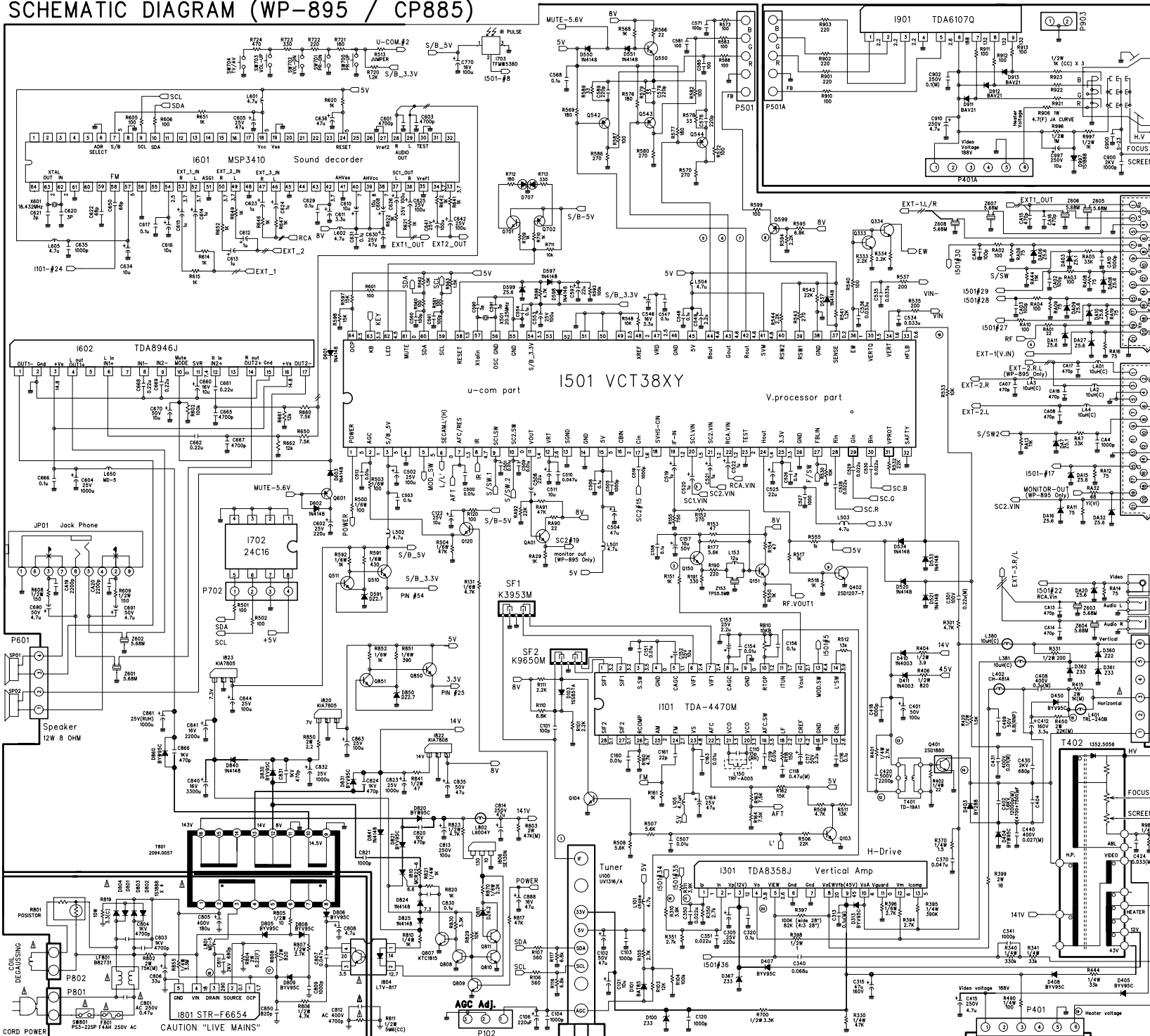

NOTE:
 1. RESISTANCE IS SHOWN IN OHM. K=1000, M=1000000
 2. UNLESS OTHERWISE NOTED IN SCHEMATIC ALL CAPACITOR VALUES ARE EXPRESSED IN UF
 3. VOLTAGES READ WITH "VTVM" FROM POINT INDICATED TO CHASSIS GROUND USING A COLOR BAR SIGNAL WITH ALL CONTROLS AT NORMAL LINE 230V AC VOLTAGE READINGS SHOWN ARE NORMAL VALUES AND MAY VARY +20% EXCEPT H.V.
 4. THIS CIRCUIT DIAGRAM IS A STANDARD ONE CIRCUIT PRINTED MAY BE SUBJECT TO CHANGE FOR PRODUCT IMPROVEMENT WITHOUT PRIOR NOTICE

WARNING:
 BEFORE SERVICING THE CHASSIS, READ "X-RAY RADIATION", "SAFETY PRECAUTIONS", AND "PRODUCT SAFETY NOTICE" IN SERVICE MANUAL

CAUTION TO SERVICE TECHNICIANS:
 BEFORE RETURNING THE RECEIVER TO CUSTOMER, MEASURE CURRENT OR RESISTANCE MEASUREMENTS SHOULD BE PERFORMED TO DETERMINE THAT EXPOSED PARTS ARE PROPERLY INSULATED FROM THE SUPPLY CIRCUIT.

RESISTOR	CAPACITOR	COIL
CARBON FILM	WAX	RELAYING
S.M.-CODE	ELECTRO	CHOKE
CARBON COMP.	CERAMIC	BEAD
FUSIBLE	CERAMIC CH	
CEMENT	ELECTRO NON-POL.	
	MYLAR	

THE DIFFERENT PARTS FOR CRT

LOC.	28" WIDE PHILIPS	28" WIDE LG	28"/25" PHILIPS	28"/25" THOMSON
C408	400V 0.5u(M)	400V 0.5u (M)	400V 0.27u (M)	400V 0.27u(M)
L401	TRL-240B	TRL-400DE	TRL-330	TRL-330
R310	3.9K	2.4K	3.3K	2.2K
R311	3.9K	2.4K	3.3K	2.2K
R312	2.7K	4.3K	3.3K	4.3K
R313	2.7K	4.3K	3.3K	4.3K
R331	1/2W 100k	1/2W 200	1/2W 200	1/2W 200
R250	1W 4.7kA (F)	1W 4.7kA (F)	1W 2.4 JA (F)	1W 1.5A(F)
Y901	W66C000013	W66C002400B	AA66A0570T1	AA66C130011
C403	16KV 10000pF	16KV 10000pF	16KV 10000pF	16KV 10000pF
R308	1/2W 100k	1/2W 100k	1/2W 100k	1/2W 100k
R307	1/8W 100k	1/8W 100k	1/8W 100k	1/8W 100k
R444	JUMPER	JUMPER	1/2W 200	JUMPER
T401	1552.5056	1552.5056	1552.5060	1552.5060
R395	390K	390K	390K	390K

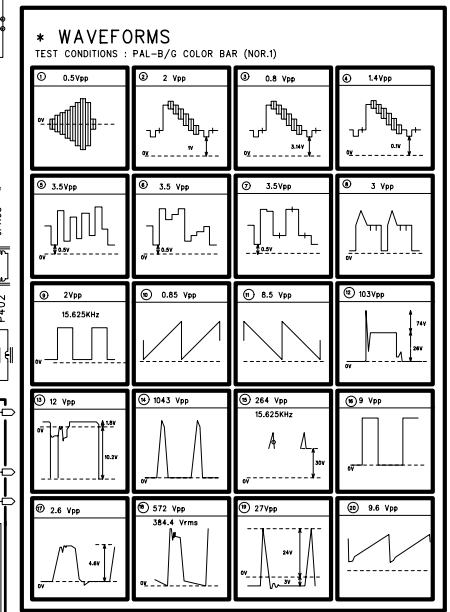

(MAY/2001)
 S/N : 4859805093-00

PRODUCT SAFETY NOTE:
 THE COMPONENTS MARKED WITH ⚡ ARE IMPORTANT FOR MAINTAINING THE SAFETY OF THE SET AND SHOULD BE REPLACED ONLY WITH TYPES IDENTICAL TO THOSE IN THE ORIGINAL OR SPECIFIED ONE IN THE PART LIST. DON'T DEGRADE THE SAFETY OF THE SET THROUGH IMPROPER SERVICING.

SCHEMATIC DIAGRAM (WP-895F/CP-885F)

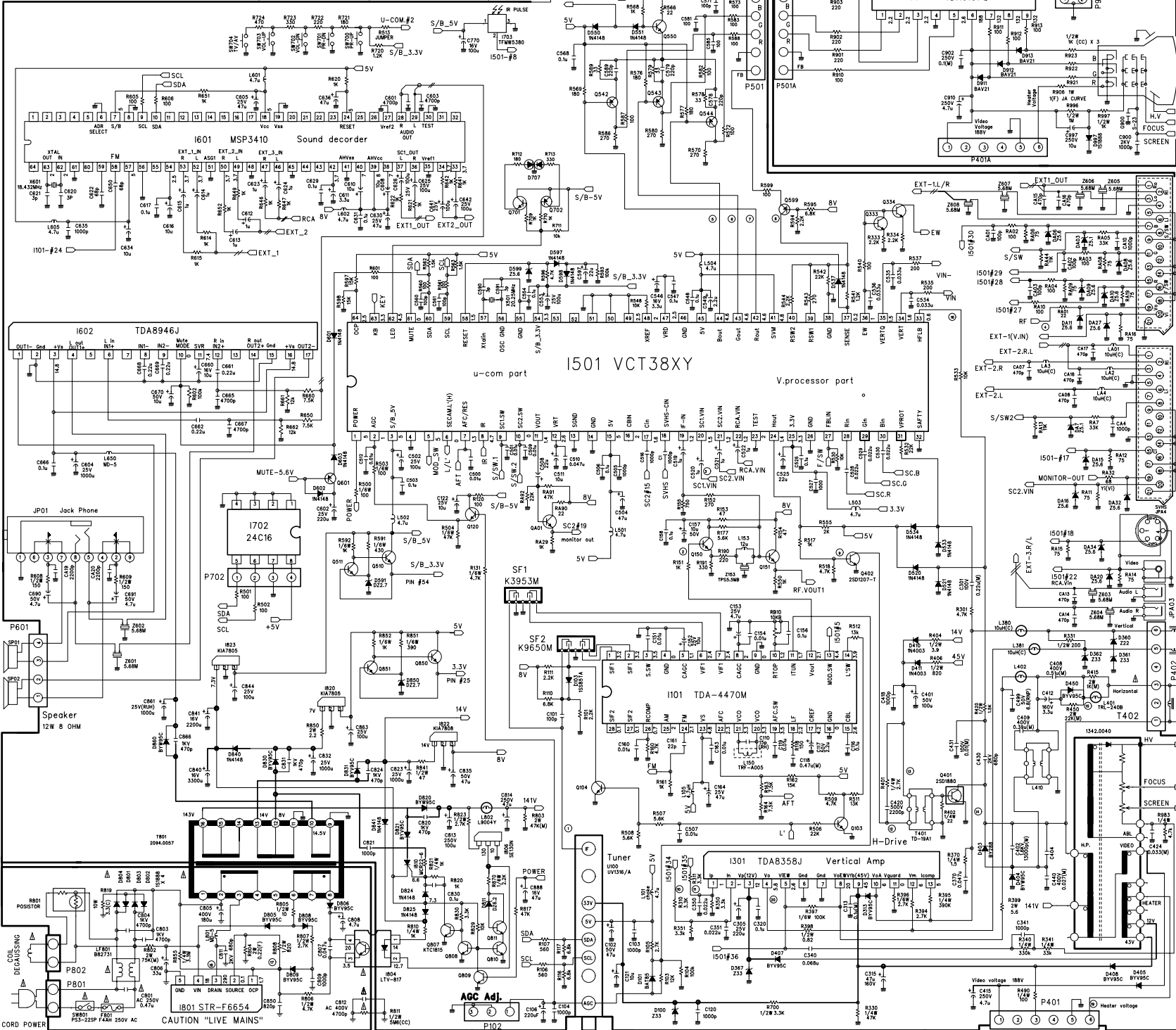

- NOTE:**
1. RESISTANCE IS SHOWN IN OHM. K=1000, M=1000000
 2. UNLESS OTHERWISE NOTED IN SCHEMATIC ALL CAPACITOR VALUES ARE EXPRESSED IN UF
 3. VOLTAGES READ WITH "VTVM" FROM POINT INDICATED TO CHASSIS GROUND USING A COLOR BAR SIGNAL WITH ALL CONTROLS AT NORMAL LINE 230V AC VOLTAGE READINGS SHOWN ARE NORMAL VALUES AND MAY VARY +20% EXCEPT H.V.
 4. THIS CIRCUIT DIAGRAM IS A STANDARD ONE CIRCUIT PRINTED MAY BE SUBJECT TO CHANGE FOR PRODUCT IMPROVEMENT WITHOUT PRIOR NOTICE

WARNING:
BEFORE SERVICING THE CHASSIS, READ "X-RAY RADIATION", "SAFETY PRECAUTION", AND "PRODUCT SAFETY NOTICE" IN SERVICE MANUAL

CAUTION TO SERVICE TECHNICIANS:
BEFORE RETURNING THE RECEIVER TO CUSTOMER, LEAKAGE CURRENT QR RESISTANCE MEASUREMENTS SHOULD BE PERFORMED TO DETERMINE THAT EXPOSED PARTS ARE PROPERLY INSULATED FROM THE SUPPLY CIRCUIT.

RESISTOR	CAPACITOR	COIL
CARBON FILM	ELECTRO	PEAKING
R M-OXIDE	CERAMIC	CHOKER
CARBON COMP	CERAMIC OH	BEAD
FUSIBLE	ELECTRO NONPOLAR	
CEMENT	MYLAR	

THE DIFFERENT PARTS FOR CRT

LOC.	28" WIDE THOMSON	29" 4:3 THOMSON
C401	400V 0.39u (M)	400V 0.39u (M)
L401	TRL-240B	TRL-4000E
R307	100K	82K
R350	3.3K	2.7K
R351	2.3K	2.7K
R352	3.3K	3.3K
R353	3.3K	3.9K
R399	2W 6.8	2W 5.6
R906	1W 1/4 (F)	1W 1/4 (F)
T401	WEEC70M101	AME220101
T402	14E2.50B	14E2.50B

* WAVEFORMS

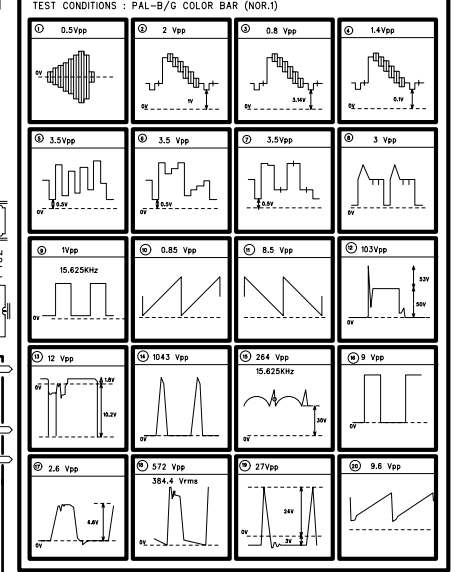

(MAY/2001)
S/N : 4859805193-00

PRODUCT SAFETY NOTE :
THE COMPONENTS MARKED WITH ⚠ ARE IMPORTANT FOR MAINTAINING THE SAFETY OF THE SET AND SHOULD BE REPLACED ONLY WITH TYPES IDENTICAL TO THOSE IN THE ORIGINAL OR SPECIFIED ONE IN THE PART LIST. DON'T DEGRADE THE SAFETY OF THE SET THROUGH IMPROPER SERVICING.

SCHEMATIC DIAGRAM (CP-485F)

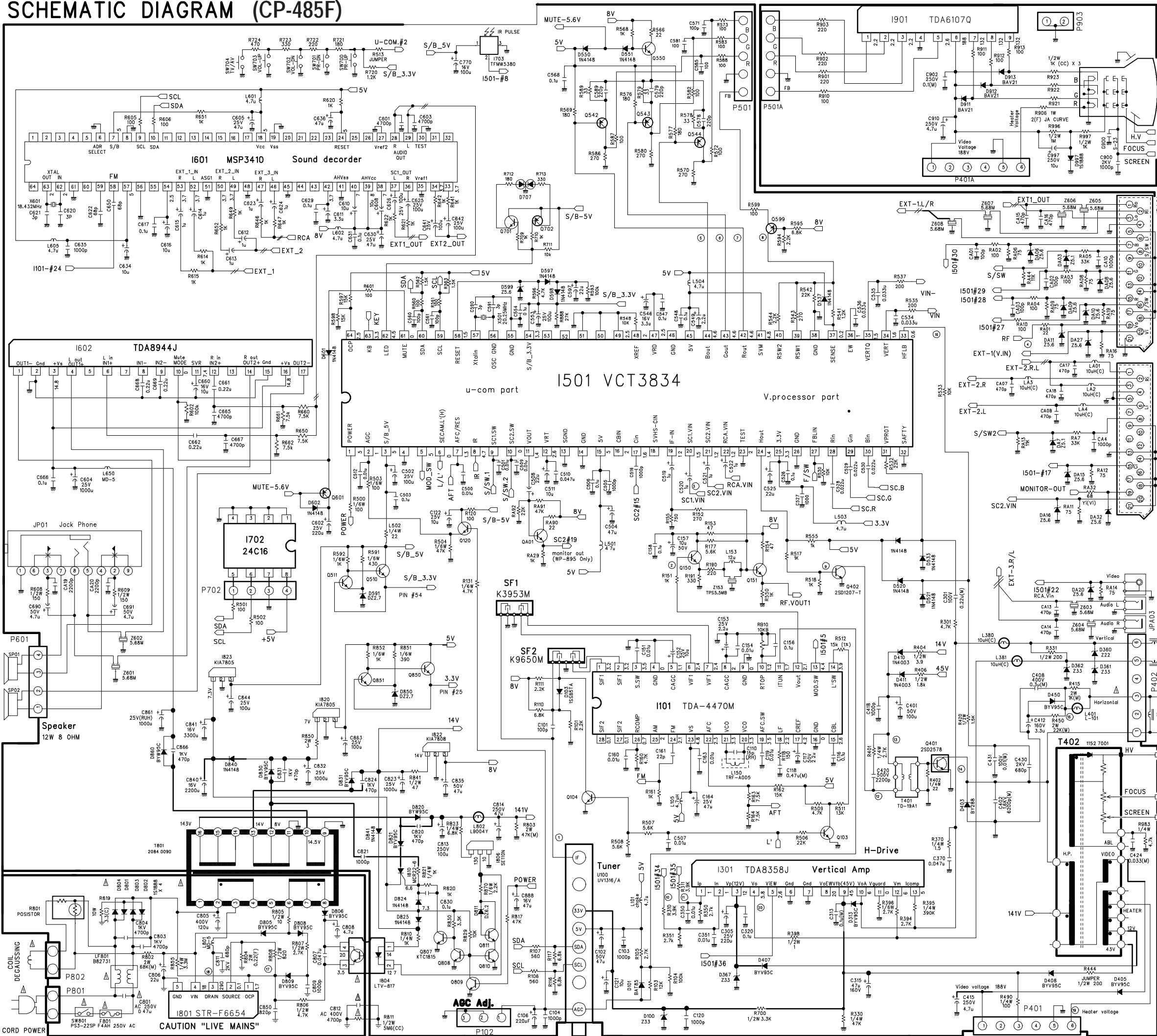

NOTE:
 1. RESISTANCE IS SHOWN IN OHM. K=1000, M=1000000
 2. UNLESS OTHERWISE NOTED IN SCHEMATIC ALL CAPACITOR VALUES ARE EXPRESSED IN μ F
 3. VOLTAGES READ WITH "VTVM" FROM POINT INDICATED TO CHASSIS GROUND USING A COLOR BAR SIGNAL WITH ALL CONTROLS AT NORMAL LINE 230V AC VOLTAGE READINGS SHOWN ARE NORMAL VALUES AND MAY VARY $\pm 20\%$ EXCEPT H.V.
 4. THIS CIRCUIT DIAGRAM IS A STANDARD ONE CIRCUIT PRINTED MAY BE SUBJECT TO CHANGE FOR PRODUCT IMPROVEMENT WITHOUT PRIOR NOTICE

WARNING:
 BEFORE SERVICING THE CHASSIS, READ "X-RAY RADIATION", "SAFETY PRECAUTION", AND "PRODUCT SAFETY NOTICE" IN SERVICE MANUAL

CAUTION TO SERVICE TECHNICIANS:
 BEFORE RETURNING THE RECEIVER TO CUSTOMER, LEAKAGE CURRENT OR RESISTANCE MEASUREMENTS SHOULD BE PERFORMED TO DETERMINE THAT EXPOSED PARTS ARE PROPERLY INSULATED FROM THE SUPPLY CIRCUIT.

RESISTOR	CAPACITOR	COIL
CARBON FILM	ELECTRO	PEAKING
R M-OXIDE	CERAMIC	CHOKE
CARBON COMP	CERAMIC CH	BEAD
FUSIBLE	ELECTRO NONPOLAR	
CEMENT	MYLAR	

* WAVEFORMS

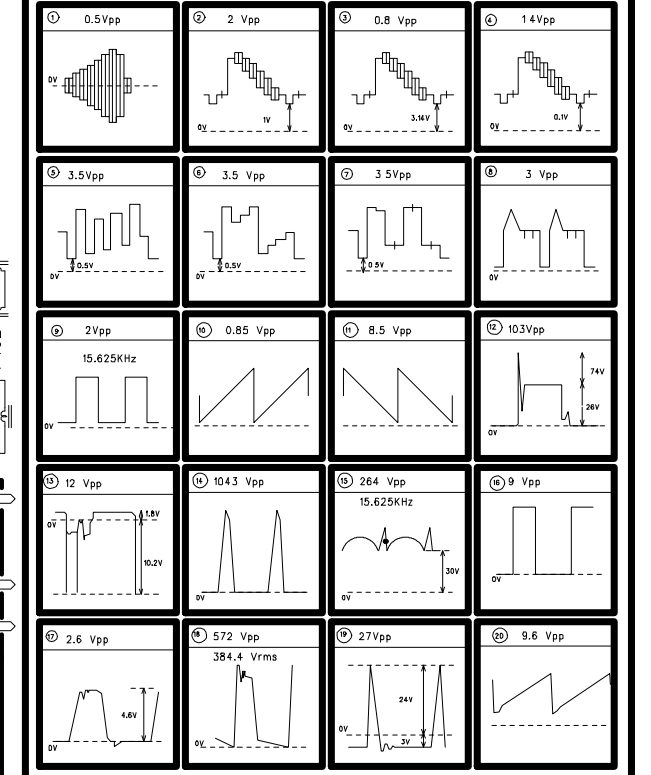

(FEB/2002)
 S/N : 4859805093-04

PRODUCT SAFETY NOTE :
 THE COMPONENTS MARKED WITH Δ ARE IMPORTANT FOR MAINTAINING THE SAFETY OF THE SET AND SHOULD BE REPLACED ONLY WITH TYPES IDENTICAL TO THOSE IN THE ORIGINAL OR SPECIFIED ONE IN THE PART LIST. DON'T DEGRADE THE SAFETY OF THE SET THROUGH IMPROPER SERVICING.