

SPECIFICATION

Items		Contents
Dimensions (W × H × D)		84.7cm × 52.2cm × 26.0cm [Included stand] 84.7cm × 49.0cm × 10.2cm [TV only]
Mass		14.8kg [Included stand] 13.0kg [TV only]
Power Input		AC100 to AC240 V, 50 Hz
Power Consumption		150W (Standby: 4.0W)
TV RF System		CCIR B/G, I, D/K, L
Colour System		PAL / SECAM / NTSC 3.58 / NTSC 4.43 (NTSC: EXT only).
Stereo System		A2 (B/G, D/K), NICAM (B/G, I, D/K, L)
Teletext System		FLOF (Fastext), TOP, WST (World Standard System)
Receiving Frequency	VHF UHF CATV	47MHz to 470MHz 470MHz to 862MHz 116MHz to 172MHz / 220MHz to 469MHz
Intermediate Frequency	VIF SIF	38.9MHz(B/G, D/K, I) 33.4MHz(5.5MHz:B/G) / 32.9MHz(6.0MHz:I) / 32.4MHz(6.5MHz:L,D/K)
Colour Sub Carrier Frequency	PAL SECAM NTSC	4.43MHz 4.40625MHz / 4.25MHz 3.58MHz / 4.43MHz
LCD panel		30V-inch wide aspect (15:9)
Screen Size		Diagonal : 51.1cm (H:64.3cm × V : 38.6cm)
Display Pixels		Horizontal : 1280 dots × Vertical : 768 dots (WXGA)
Audio Power Output		8W + 8W(10% THD)
Speaker		5.0cm, round type × 2
Aerial terminal (VHF/UHF)		F-type connector, 75Ω unbalanced, coaxial
EXT-1 / EXT-2 (Input / Output)		21-pin Euro connector (SCART socket) × 2
EXT-3(Input)	Component Video 625p / 525p / 625i / 525i Audio	RCA pin jack × 3 Y : 1V (p-p), Positive (Negative sync provided), 75 Ω Cb/Cr : 0.7V(p-p), 75 Ω 500mV(rms) (-4dBs), high impedance, RCA pin jack × 2
EXT-4 (Input)	S-Video Video Audio	Mini-DIN 4 pin × 1 Y: 1V (p-p), Positive (Negative sync provided), 75 Ω C: 0.286V (p-p) (Burst signal), 75 Ω 1V (p-p), Positive (Negative sync provided), 75 Ω, RCA pin jack × 1 500mV (rms), High impedance, RCA pin jack × 2
PC (RGB) Input		D-sub 15pin × 1 R/G/B : 0.7V (p-p), 75Ω HD / VD : 1V (p-p) to 5V (p-p), high impedance < Available signal > VGA : 640 pixels × 480 pixels (Horizontal : 31.5kHz / Vertical : 60Hz) XGA : 1024 pixels × 768 pixels (Horizontal : 48.4kHz / Vertical : 60Hz)
PC AUDIO input		3.5mm stereo mini jack × 1
Audio output		500mV (rms), Low impedance, RCA pin jack × 2
Subwoofer output		More than 0 to 1000mV (rms) (+2.2dBs), low impedance (80Hz when modulated 100%), RCA pin jack × 1
Headphone		3.5mm stereo mini jack × 1
Remote Control Unit		RM-C1860 (AA/R6 dry cell battery × 2)

Design & specifications are subject to change without notice.

SECTION 1 PRECAUTION

1.1 SAFETY PRECAUTIONS

- (1) The design of this product contains special hardware, many circuits and components specially for safety purposes. For continued protection, no changes should be made to the original design unless authorized in writing by the manufacturer. Replacement parts must be identical to those used in the original circuits. Service should be performed by qualified personnel only.
- (2) Alterations of the design or circuitry of the products should not be made. Any design alterations or additions will void the manufacturer's warranty and will further relieve the manufacturer of responsibility for personal injury or property damage resulting therefrom.
- (3) Many electrical and mechanical parts in the products have special safety-related characteristics. These characteristics are often not evident from visual inspection nor can the protection afforded by them necessarily be obtained by using replacement components rated for higher voltage, wattage, etc. Replacement parts which have these special safety characteristics are identified in the parts list of Service manual. **Electrical components having such features are identified by shading on the schematics and by (Δ) on the parts list in Service manual.** The use of a substitute replacement which does not have the same safety characteristics as the recommended replacement part shown in the parts list of Service manual may cause shock, fire, or other hazards.
- (4) **Don't short between the LIVE side ground and ISOLATED (NEUTRAL) side ground or EARTH side ground when repairing.**
Some model's power circuit is partly different in the GND. The difference of the GND is shown by the LIVE : (\perp) side GND, the ISOLATED (NEUTRAL) : (\perp) side GND and EARTH : (\oplus) side GND.
Don't short between the LIVE side GND and ISOLATED (NEUTRAL) side GND or EARTH side GND and never measure the LIVE side GND and ISOLATED (NEUTRAL) side GND or EARTH side GND at the same time with a measuring apparatus (oscilloscope etc.). If above note will not be kept, a fuse or any parts will be broken.
- (5) When service is required, observe the original lead dress. Extra precaution should be given to assure correct lead dress in the high voltage circuit area. Where a short circuit has occurred, those components that indicate evidence of overheating should be replaced. Always use the manufacturer's replacement components.

(6) Isolation Check (Safety for Electrical Shock Hazard)

After re-assembling the product, always perform an isolation check on the exposed metal parts of the cabinet (antenna terminals, video/audio input and output terminals, Control knobs, metal cabinet, screw heads, earphone jack, control shafts, etc.) to be sure the product is safe to operate without danger of electrical shock.

a) Dielectric Strength Test

The isolation between the AC primary circuit and all metal parts exposed to the user, particularly any exposed metal part having a return path to the chassis should withstand a voltage of 3000V AC (r.m.s.) for a period of one second. (. . . Withstand a voltage of 1100V AC (r.m.s.) to an appliance rated up to 120V, and 3000V AC (r.m.s.) to an appliance rated 200V or more, for a period of one second.) This method of test requires a test equipment not generally found in the service trade.

b) Leakage Current Check

Plug the AC line cord directly into the AC outlet (do not use a line isolation transformer during this check.). Using a "Leakage Current Tester", measure the leakage current from each exposed metal part of the cabinet, particularly any exposed metal part having a return path to the chassis, to a known good earth ground (water pipe, etc.). Any leakage current must not exceed 0.5mA AC (r.m.s.). However, in tropical area, this must not exceed 0.2mA AC (r.m.s.).

Alternate Check Method

Plug the AC line cord directly into the AC outlet (do not use a line isolation transformer during this check.). Use an AC voltmeter having 1000Ω per volt or more sensitivity in the following manner. Connect a 1500Ω 10W resistor paralleled by a $0.15\mu\text{F}$ AC-type capacitor between an exposed metal part and a known good earth ground (water pipe, etc.). Measure the AC voltage across the resistor with the AC voltmeter. Move the resistor connection to each exposed metal part, particularly any exposed metal part having a return path to the chassis, and measure the AC voltage across the resistor. Now, reverse the plug in the AC outlet and repeat each measurement. Any voltage measured must not exceed 0.75V AC (r.m.s.). This corresponds to 0.5mA AC (r.m.s.). However, in tropical area, this must not exceed 0.3V AC (r.m.s.). This corresponds to 0.2mA AC (r.m.s.).

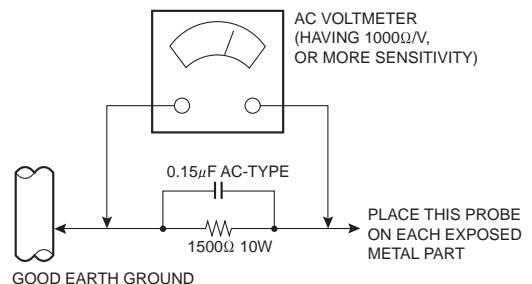

1.2 INSTALLATION

1.2.1 HEAT DISSIPATION

If the heat dissipation vent behind this unit is blocked, cooling efficiency may deteriorate and temperature inside the unit will rise. The temperature sensor that protects the unit will be activated when internal temperature exceeds the pre-determined level and power will be turned off automatically. Therefore, please make sure pay attention not to block the heat dissipation vent as well as the ventilation outlet behind the unit and ensure that there is room for ventilation around it.

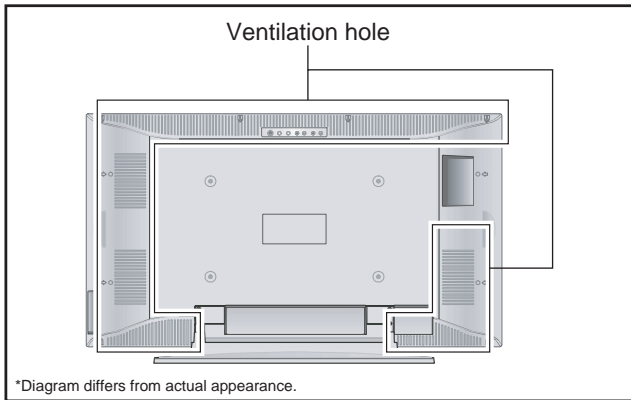

1.2.2 INSTALLATION REQUIREMENTS

Ensure that the minimal distance is maintained, as specified below, between the unit with and the surrounding walls, as well as the floor etc. Install the unit on stable flooring or stands. Take precautionary measures to prevent the unit from tipping in order to protect against accidents and earthquakes.

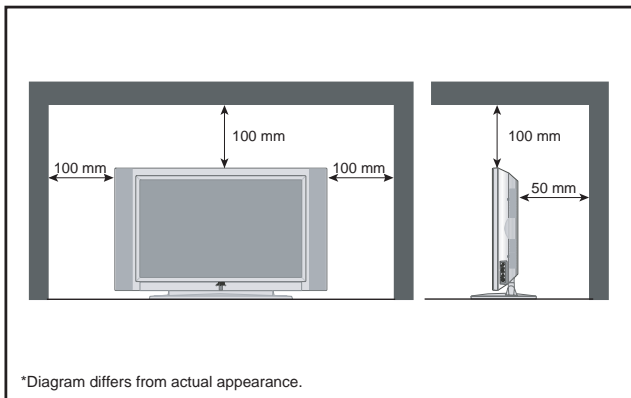

1.2.3 INSTALLATION REQUIREMENTS

To ensure safety in an emergency such as an earthquake, and to prevent accidents, ensure that measures are taken to prevent the TV dropping or falling over.

Use the supplied screws to firmly attach the supplied hooks (OPTION) to the back of the TV, and use commercially available cord to fix the TV to rigid components such as walls and columns.

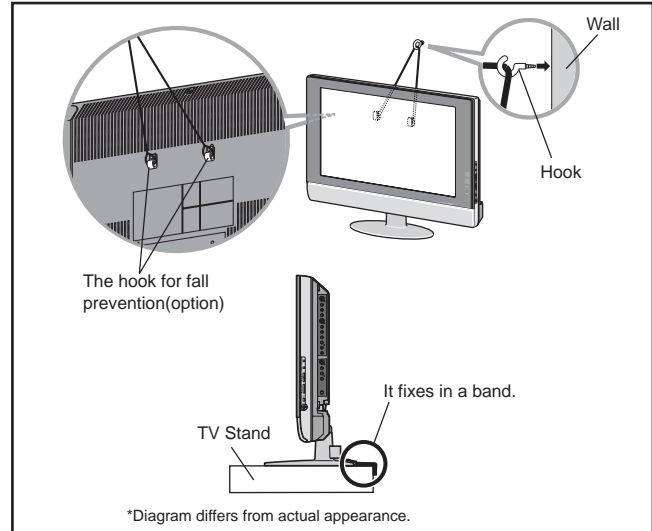

1.2.4 NOTES ON HANDLING

(1) WHEN TAKING UNIT OUT OF A PACKING CASE

When taking the unit out of a packing case, do not grasp the upper part of the unit. If you take the unit out while grasping the upper part, the LCD PANEL may be damaged because of a pressure. Instead of grasping the upper part, put your hands on the lower backside or sides of the unit.

(2) AS FOR PRESSING OR TOUCHING A SPEAKER

Be careful not to press the opening of the speaker in the lower part of the unit and around them since the decorative sheet on the surface of the openings may be deformed.

1.3 HANDLING LCD PANEL

1.3.1 PRECAUTIONS FOR TRANSPORTATION

When transporting the unit, pressure exerted on the internal LCD panel due to improper handling (such as tossing and dropping) may cause damages even when the unit is carefully packed. To prevent accidents from occurring during transportation, pay careful attention before delivery, such as through explaining the handling instructions to transporters.

Ensure that the following requirements are met during transportation, as the LCD panel of this unit is made of glass and therefore fragile:

(1) USE A SPECIAL PACKING CASE FOR THE LCD PANEL

When transporting the LCD panel of the unit, use a special packing case (packing materials). A special packing case is used when a LCD panel is supplied as a service spare part.

(2) ATTACH PROTECTION SHEET TO THE FRONT

Since the front (display part) of the panel is vulnerable, attach the protection sheet to the front of the LCD panel before transportation. Protection sheet is used when a LCD panel is supplied as a service spare part.

(3) AVOID VIBRATIONS AND IMPACTS

The unit may be broken if it is toppled sideways even when properly packed. Continuous vibration may shift the gap of the panel, and the unit may not be able to display images properly. Ensure that the unit is carried by at least 2 persons and pay careful attention not to exert any vibration or impact on it.

(4) DO NOT PLACE EQUIPMENT HORIZONTALLY

Ensure that it is placed upright and not horizontally during transportation and storage as the LCD panel is very vulnerable to lateral impacts and may break. During transportation, ensure that the unit is loaded along the traveling direction of the vehicle, and avoid stacking them on one another. For storage, ensure that they are stacked in 2 layers or less even when placed upright.

1.3.2 OPTICAL FILTER (ON THE FRONT OF THE LCD PANEL)

- (1) Avoid placing the unit under direct sunlight over a prolonged period of time. This may cause the optical filter to deteriorate in quality and COLOUR.
- (2) Clean the filter surface by wiping it softly and lightly with a soft and lightly fuzz cloth (such as outing flannel).
- (3) Do not use solvents such as benzene or thinner to wipe the filter surface. This may cause the filter to deteriorate in quality or the coating on the surface to come off. When cleaning the filter, usually use the neutral detergent diluted with water. When cleaning the dirty filter, use water-diluted ethanol.
- (4) Since the filter surface is fragile, do not scratch or hit it with hard materials. Be careful enough not to touch the front surface, especially when taking the unit out of the packing case or during transportation.

1.3.3 PRECAUTIONS FOR REPLACEMENT OF EXTERIOR PARTS

Take note of the following when replacing exterior parts (REAR COVER, FRONT PANEL, etc.):

- (1) Do not exert pressure on the front of the LCD panel (filter surface). It may cause irregular COLOUR.
- (2) Pay careful attention not to scratch or stain the front of the LCD panel (filter surface) with hands.
- (3) When replacing exterior parts, the front (LCD panel) should be placed facing downward. Place a mat, etc. underneath to avoid causing scratches to the front (filter surface).

SECTION 2

SPECIFIC SERVICE INSTRUCTIONS

2.1 FEATURES

T-V LINK

When you have a T-V LINK compatible VCR connected to the EXT-2 Terminal on the TV, it is easier to set up the VCR and to view videos.

OFF TIMER

This function can set the TV to automatically turn off after a set time.

ZOOM

This function can change the screen size according to the picture aspect ratio.

COLOUR SYSTEM

If the picture is not clear or no colour appears, change the current colour system to another colour system.

2.2 MAIN DIFFERENCE LIST

Items	LT-30E45SU	LT-30E45SJ	LT-30E45SU/Z	LT-30E45SU/N
POWER CORD	EU type(2-pin)	UK type(3-pin)	SWE Type(3-pin)	EU type(2-pin)
AV JACK PWB	VE-20185947	←	←	VE-20148274

2.3 21-PIN EURO CONNECTOR (SCART) : EXT-1 / EXT-2

Pin No.	Signal designation	Matching value	EXT-1	EXT-2
1	AUDIO R output	500mV(rms) (Nominal),, Low impedance	Used (TV OUT)	Used (LINE OUT)
2	AUDIO R input	500mV(rms) (Nominal),, High impedance	Used (R1)	Used (R2)
3	AUDIO L output	500mV(rms) (Nominal),, Low impedance	Used (TV OUT)	Used (LINE OUT)
4	AUDIO GND		Used	Used
5	GND (B)		Used	Used
6	AUDIO L input	500mV(rms) (Nominal),, High impedance	Used (L1)	Used (L2)
7	B input	700mV _(B-W) , 75Ω	Used	Used
8	FUNCTION SW (SLOW SW)	Low : 0V-3V High : 8V-12V, High impedance	Used	Used
9	GND (G)		Used	Used
10	SCL / T-V LINK		Not used	Used (SCL2 / TV-LINK)
11	G input	700mV _(B-W) , 75Ω	Used	Used
12	SDA		Not used	Used (SDA2)
13	GND (R)		Used	Used
14	GND (YS)		Used	Not used
15	R / C input	R : 700mV _(B-W) , 75Ω C : 300mV _(P-P) , 75Ω	Used (R)	Used (C2/R)
16	Ys input (FAST SW)	Low : 0V-0.4V, High : 1V-3V, 75Ω	Used	Used
17	GND (VIDEO output)		Used	Used
18	GND (VIDEO input)		Used	Used
19	VIDEO output	1V _(P-P) (Negative sync), 75Ω	Used (TV OUT)	Used (LINE OUT)
20	VIDEO / Y input	1V _(P-P) (Negative sync), 75Ω	Used	Used
21	COMMON GND		Used	Used

(P-P= Peak to Peak, B-W= Blanking to white peak)

[Pin assignment]

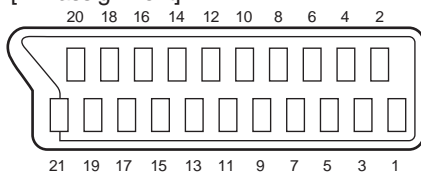

2.4 TECHNICAL INFORMATION

2.4.1 LCD PANEL

This unit uses the flat type panel LCD (Liquid Crystal Display) panel that occupies as little space as possible, instead of the conventional CRT (Cathode Ray Tube), as a display unit.

Since the unit has the two polarizing filter that are at right angles to each other, the unit adopts "normally black" mode, where light does not pass through the polarizing filter and the screen is black when no voltage is applied to the liquid crystals.

2.4.1.1 SPECIFICATIONS

The following table shows the specifications of this unit.

Item	Specifications	Remarks
Displayed colour	16777216 colours	256 colours for R, G, and B
Brightness	500cd/m ²	
Contrast ratio	600: 1	
Response time	15ms	
View angle	Horizontally: 170°, Vertically: 170°	

2.4.1.2 PIXEL FAULT

There are three pixel faults - bright fault , dark fault and flicker fault - that are respectively defined as follows.

■ BRIGHT FAULT

In this pixel fault, a cell that should not light originally is lighting on and off.

For checking this pixel fault, input ALL BLACK SCREEN and find out the cell that is lighting on and off.

■ DARK FAULT

In this pixel fault, a cell that should light originally is not lighting or lighting with the brightness twice as brighter as originally lighting.

For checking this pixel fault, input 100% of each R/G/B colour and find out the cell that is not lighting.

■ FLICKER FAULT

In the pixel fault, a cell that should light originally or not light originally is flashing on and off.

For checking this pixel fault, input ALL BLACK SCREEN signal or 100% of each RGB colour and find out the cell that is flashing on and off.

2.5 BASIC OPERATION OF SERVICE MODE

2.5.1 HOW TO ENTER THE SERVICE MODE

- (1) Press **[MENU]** key on the remote control unit simultaneously to display the MENU SCREEN.
- (2) In the MENU SCREEN, press the **[4]**, **[7]**, **[2]** and **[5]** key.
- (3) The following menu appears on the screen.

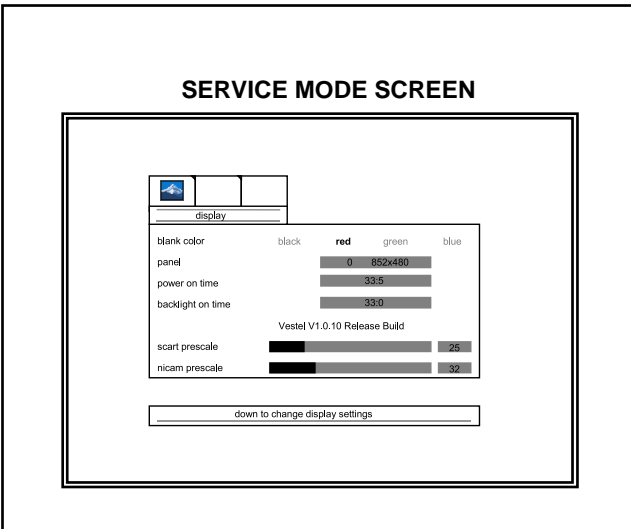

2.5.2 HOW TO EXIT THE SERVICE MODE

Press the **[MENU]** key to exit the Service mode.

2.5.3 CHANGE AND MEMORY OF SETTING VALUE

■ SELECTION OF SETTING MENU & ITEM

- **[FUNCTION ▲/▼]** key: Select the SETTING MENU & ITEM
- **[OK]** key: Decision the SETTING MENU & ITEM

■ CHANGE OF SETTING VALUE (DATA)

- **[FUNCTION ◀/▶]** key.

■ MEMORY OF SETTING VALUE (DATA)

The setting value will be stored automatically when release the REMOTE CONTROL UNIT keys

2.5.4 SERVICE MODE SELECT KEY LOCATION

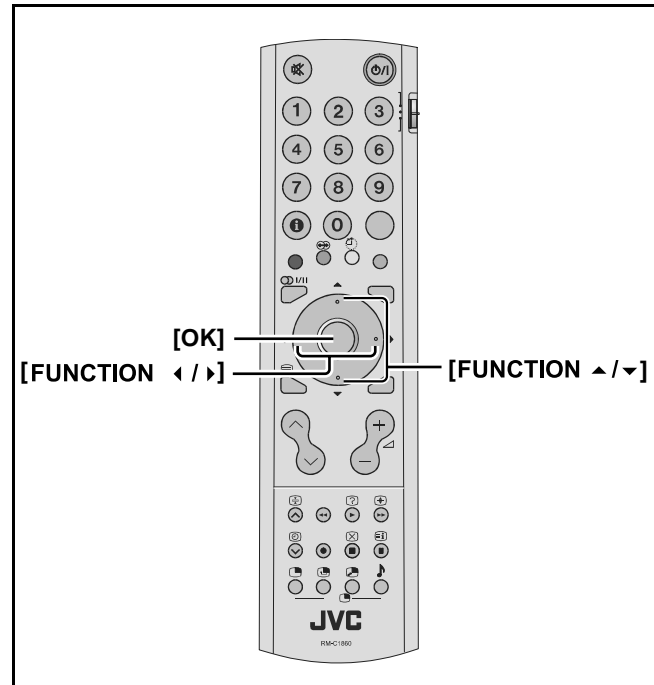

2.5.5 SERVICE MODE SETTING ITEMS

Setting menu	Setting items	Variable range	Setting value
display	blank color	brack / red / green / blue	black
	scart prescale	0 - 127	14
	nicam prescale	0 - 127	35
	fm/am prescale	0 - 127	16
	subwoofer corner	0 - 7	5
	subwoofer level	0 - 32	32
	agc	0 - 31	16
calibration	color temperature	5500K / 6500K / 7500K / 9300K / user	5500K
	color temperature-user	5500K / 6500K / 7500K / 9300K	5500K
	video format	auto / ntsc / pal / secam / ntsc	auto
	color space	RGB / YPbPr SMPTE240 / YPbPr REC709 / YCbCr REC601	RGB
	test pattern	none / solid color / vert bars.	none
	color components	all / red / green / blue.	all
	solid field level	0 - 64	33
	initial aps	on / off	on
deinterlacer	black expansion	on / off	These values are not recorded for this reason they are adjusted to aspecified value.
	dcti	0 - 255	
	dlti	0 - 255	
	luminance peaking	on / off	
	film mode	on / off	
	film mode speed	0 / 1 / 2 / 3	
	vof	on / off	
	bad cut	on / off	
	nr threshold	low / high	
	noise reduction	0 - 255	
	lai level	0 / 1 / 2	
	sharpness	0 - 255	
	sparkle	0 - 255	

SECTION 3

DISASSEMBLY

3.1 DISASSEMBLY PROCEDURE

NOTE:

- Make sure that the power cord is disconnected from the outlet.
- Pay special attention not to break or damage the parts.
- When removing each board, remove the connectors as required. Taking notes of the connecting points (connector numbers) makes service procedure manageable.
- Make sure that there is no bent or stain on the connectors before inserting, and firmly insert the connectors.

3.1.1 REMOVING THE STAND (Fig.1)

- (1) Remove the 4 screws [A], then remove the STAND.

3.1.2 REMOVING THE REAR COVER (Fig.1)

- Remove the STAND.
- (1) Remove the 12 screws [B] and 4 screws [C], then remove the REAR COVER.

3.1.3 REMOVING THE MAIN PWB (Fig.1)

- Remove the STAND.
 - Remove the REAR COVER.
- (1) Remove the 4 screws [D], then remove the RIGHT FRAME.
 - (2) Remove the 4 screws [E], then remove the LEFT FRAME.
 - (3) Remove the 2 screws [W], then remove the TERMINAL BASE.
 - (4) Remove the 8 screws [F] and 2 screws [G], then remove the MAIN PWB.

3.1.4 REMOVING THE POWER PWB (Fig.1)

- Remove the STAND.
 - Remove the REAR COVER.
- (1) Remove the 4 screws [H], then remove the POWER PWB.

3.1.5 REMOVING THE POWER UNIT (Fig.1)

- Remove the STAND.
 - Remove the REAR COVER.
- (1) Remove the 4 screws [J], then remove the POWER UNIT.

3.1.6 REMOVING THE CONTROL BOTTON PWB (Fig.1)

- Remove the STAND.
 - Remove the REAR COVER.
- (1) Remove the 3 screws [K], then remove the CONTROL BOTTON PWB.

3.1.7 REMOVING THE FAV PWB (Fig.1)

- Remove the STAND.
 - Remove the REAR COVER.
- (1) Remove the 2 screws [L], then remove the CONTROL BASE with FAV PWB.
 - (2) Remove the 2 screws [M], then remove the FAV PWB from the CONTROL BASE.

3.1.8 REMOVING THE AMPLIFIRE PWB (Fig.1)

- Remove the STAND.
 - Remove the REAR COVER.
- (1) Remove the 4 screws [N], then remove the AMPLIFIRE PWB.

3.1.9 REMOVING THE NOISE FILTER PWB (Fig.1)

- Remove the STAND.
 - Remove the REAR COVER.
- (1) Remove the 3 screws [P], 2 screws [R] and 1 screw [Q], then remove the NOISE FILTER PWB.

3.1.10 REMOVING THE LED PWB (Fig.1)

- Remove the STAND.
 - Remove the REAR COVER.
- (1) Remove the 2 screws [T], then remove the LED PWB.

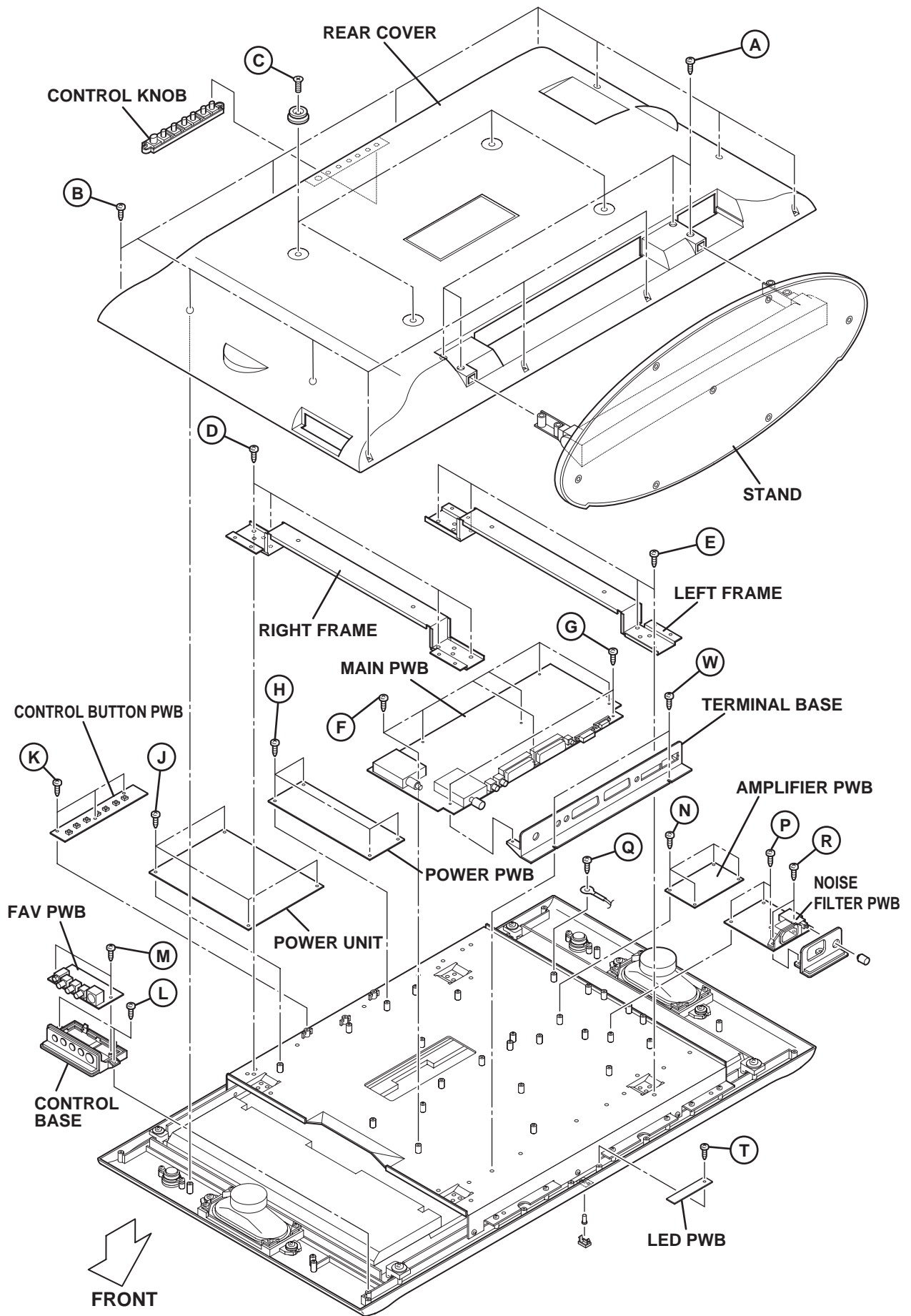

Fig.1

3.1.11 REMOVING THE SPEAKER (Fig.2)

- Remove the STAND.
- Remove the REAR COVER.
 - (1) Remove the 4 screws **[A]**, then remove the SPEAKER with SPEAKER BASE.
 - (2) Remove the 4 screws **[B]**, then remove the SUB SPEAKER (L/R).
 - (3) Remove the 8 screws **[C]**, then remove the SPEAKER from the SPEAKER BASE.

3.1.12 REMOVING THE LCD PANEL UNIT (Fig.2)

- Remove the STAND.
- Remove the REAR COVER.
 - (1) Remove the 4 screws **[D]** and the 12 screws **[E]**, then remove the LCD PANEL UNIT with the MAIN BASE.
 - (2) Remove the 4 screws **[F]**, then remove the MAIN BASE from the LCD PANEL UNIT.

NOTE:

- Pay special attention not to break or damage on the LCD PANEL face or frame.
- The LCD PANEL UNIT is fixed to the FRONT COVER (at the back side) by using double-side adhesive tapes. To remove the LCD PANEL UNIT, remove the adhesive tape on the FRONT PANELS slowly.

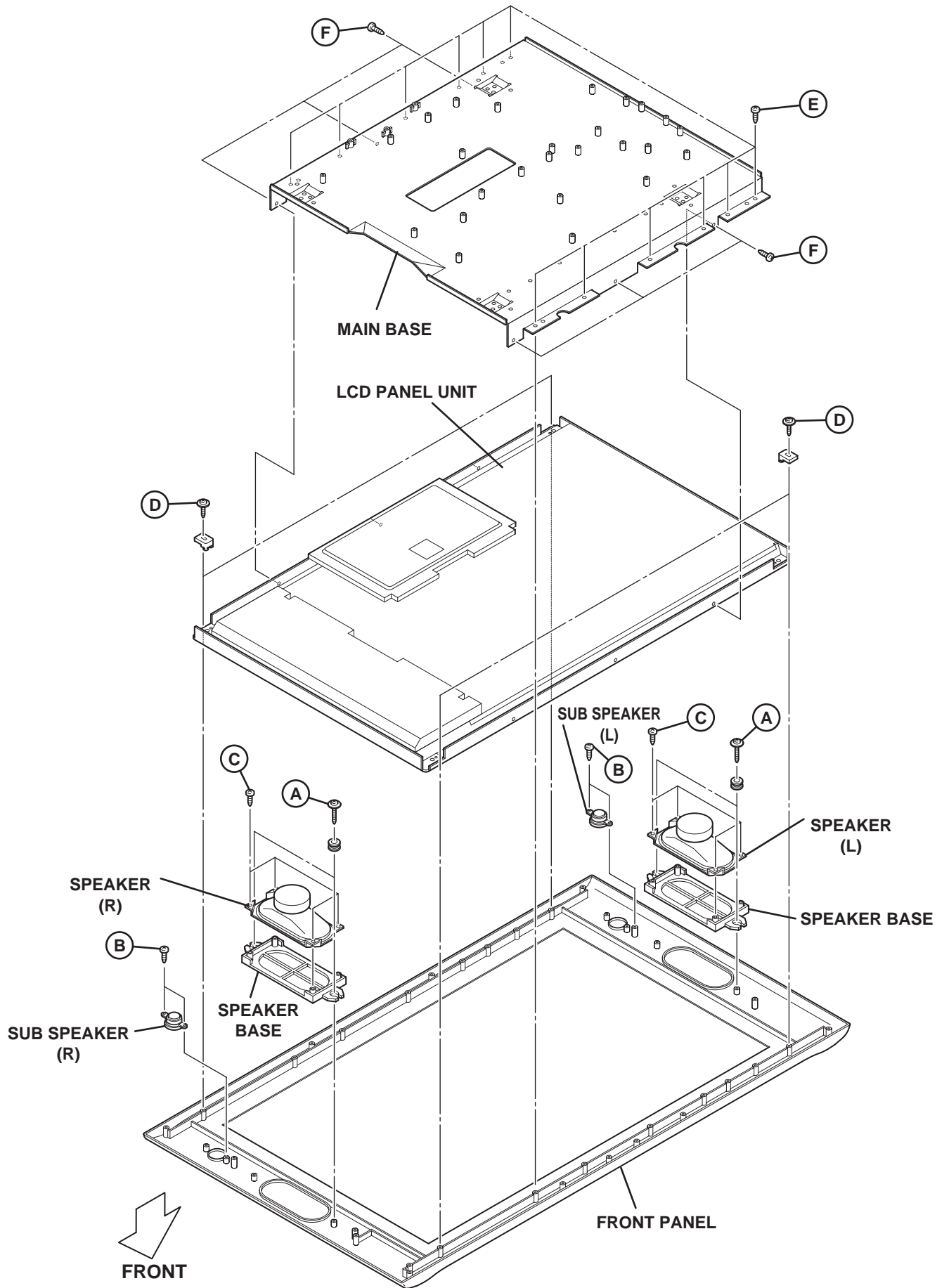

Fig.2

3.2 MEMORY IC REPLACEMENT

- This model uses the memory IC.
- This memory IC stores data for proper operation of the video and drive circuits.
- When replacing, be sure to use an IC containing this (initial value) data.

3.2.1 SETTINGS OF FACTORY SHIPMENT

3.2.1.1 BUTTON OPERATION

Setting item	Setting position
POWER	Off
VOLUME	21
TV/AV	TV

3.2.1.2 REMOTE CONTROL DIRECT OPERATION

Setting item	Setting position
ZOOM	AUTO

3.2.1.3 REMOTE CONTROL MENU OPERATION

(1) PICTURE

Setting item	Setting position
brightness	61
Contrast	36
Sharpness	50
Color	43
tint	50
phase (PC signal input only)	50

(2) WINDOW

Setting item	Setting position	
image size	TV/EXT	Auto
	PC	Fill all
pip size (pip selected only)	10	
pip position (pip selected only)	upper left position	
h position (PC signal input only)	10	
v position (PC signal input only)	21	

(3) AUDIO

Setting item	Setting position	
volume	21	
hp volume	19	
hp sound mode	Autodetected	
balance	0	
equalizer	120Hz	flat
	500Hz	flat
	1.5kHz	flat
	5kHz	flat
	10kHz	flat
hyper sound	OFF	
Dynamic bass	OFF	

(4) OPTIONS

Setting item	Setting position
language	english
vcr	OFF
osd timeout	15
menu background	Translucent
child lock	OFF
scart 2 out	Scart 1
sleep timer	0

3.3 REPLACEMENT OF CHIP COMPONENT

3.3.1 CAUTIONS

- (1) Avoid heating for more than 3 seconds.
- (2) Do not rub the electrodes and the resist parts of the pattern.
- (3) When removing a chip part, melt the solder adequately.
- (4) Do not reuse a chip part after removing it.

3.3.2 SOLDERING IRON

- (1) Use a high insulation soldering iron with a thin pointed end of it.
- (2) A 30w soldering iron is recommended for easily removing parts.

3.3.3 REPLACEMENT STEPS

1. How to remove Chip parts

[Resistors, capacitors, etc.]

- (1) As shown in the figure, push the part with tweezers and alternately melt the solder at each end.

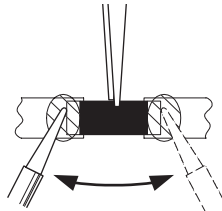

- (2) Shift with the tweezers and remove the chip part.

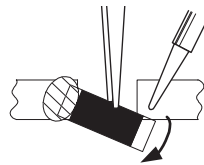

[Transistors, diodes, variable resistors, etc.]

- (1) Apply extra solder to each lead.



- (2) As shown in the figure, push the part with tweezers and alternately melt the solder at each lead. Shift and remove the chip part.

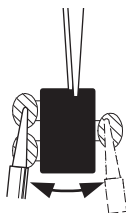

NOTE :

After removing the part, remove remaining solder from the pattern.

2. How to install Chip parts

[Resistors, capacitors, etc.]

- (1) Apply solder to the pattern as indicated in the figure.

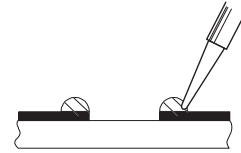

- (2) Grasp the chip part with tweezers and place it on the solder. Then heat and melt the solder at both ends of the chip part.

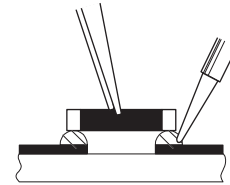

[Transistors, diodes, variable resistors, etc.]

- (1) Apply solder to the pattern as indicated in the figure.
- (2) Grasp the chip part with tweezers and place it on the solder.
- (3) First solder lead **A** as indicated in the figure.

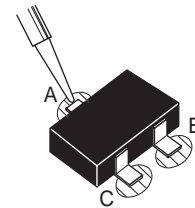

- (4) Then solder leads **B** and **C**.

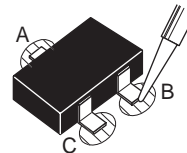

SECTION 4 ADJUSTMENT

This service manual does not describe ADJUSTMENT.

SECTION 5 TROUBLESHOOTING

This service manual does not describe TROUBLESHOOTING.

LT-30E45SU, LT-30E45SJ, LT-30E45SU/z, LT-30E45SU/N STANDARD CIRCUIT DIAGRAM

■ NOTE ON USING CIRCUIT DIAGRAMS

1.SAFETY

The components identified by the \triangle symbol and shading are critical for safety. For continued safety replace safety critical components only with manufactures recommended parts.

2.SPECIFIED VOLTAGE AND WAVEFORM VALUES

The voltage and waveform values have been measured under the following conditions.

- (1)Input signal : Colour bar signal
- (2)Setting positions of each knob/button and variable resistor : Original setting position when shipped
- (3)Internal resistance of tester : DC 20k Ω /V
- (4)Oscilloscope sweeping time : H \Rightarrow 20 μ s / div
: V \Rightarrow 5ms / div
: Others \Rightarrow Sweeping time is specified
- (5)Voltage values : All DC voltage values

* Since the voltage values of signal circuit vary to some extent according to adjustments, use them as reference values.

3.INDICATION OF PARTS SYMBOL [EXAMPLE]

- In the PW board : R209 \rightarrow R209

4.INDICATIONS ON THE CIRCUIT DIAGRAM

(1)Resistors

● Resistance value

- No unit : [Ω]
- K : [k Ω]
- M : [M Ω]

● Rated allowable power

- No indication : 1/16 [W]
- Others : As specified

● Type

- No indication : Carbon resistor
- OMR : Oxide metal film resistor
- MFR : Metal film resistor
- MPR : Metal plate resistor
- UNFR : Uninflammable resistor
- FR : Fusible resistor

* Composition resistor 1/2 [W] is specified as 1/2S or Comp.

(2)Capacitors

● Capacitance value

- 1 or higher : [pF]
- less than 1 : [μ F]

● Withstand voltage

- No indication : DC50[V]
- Others : DC withstand voltage [V]
- AC indicated : AC withstand voltage [V]

* Electrolytic Capacitors

47/50[Example]: Capacitance value [μ F]/withstand voltage[V]

●Type

- No indication : Ceramic capacitor
- MM : Metalized mylar capacitor
- PP : Polypropylene capacitor
- MPP : Metalized polypropylene capacitor
- MF : Metalized film capacitor
- TF : Thin film capacitor
- BP : Bipolar electrolytic capacitor
- TAN : Tantalum capacitor

(3)Coils

- No unit : [μ H]
- Others : As specified

(4)Power Supply



-  : B1
-  : B2 (12V)
-  : 9V
-  : 5V

* Respective voltage values are indicated



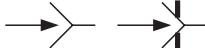

(5)Test point

-  : Test point
-  : Only test point display

(6)Connecting method

-  : Connector
-  : Wrapping or soldering
-  : Receptacle

(7)Ground symbol

-  : LIVE side ground
-  : ISOLATED(NEUTRAL) side ground
-  : EARTH ground
-  : DIGITAL ground

5.NOTE FOR REPAIRING SERVICE

This model's power circuit is partly different in the GND. The difference of the GND is shown by the LIVE (\perp) side GND and the ISOLATED(NEUTRAL) (\perp) side GND. Therefore, care must be taken for the following points.

- (1)Do not touch the LIVE side GND or the LIVE side GND and the ISOLATED(NEUTRAL) side GND simultaneously. if the above caution is not respected, an electric shock may be caused. Therefore, make sure that the power cord is surely removed from the receptacle when, for example, the chassis is pulled out.
- (2)Do not short between the LIVE side GND and ISOLATED(NEUTRAL) side GND or never measure with a measuring apparatus measure with a measuring apparatus (oscilloscope, etc.) the LIVE side GND and ISOLATED(NEUTRAL) side GND at the same time. If the above precaution is not respected, a fuse or any parts will be broken.

◆ Since the circuit diagram is a standard one, the circuit and circuit constants may be subject to change for improvement without any notice.

NOTE

◆ Due improvement in performance, some part numbers show in the circuit diagram may not agree with those indicated in the part list.

When ordering parts, please use the numbers that appear in the Parts List.

(No.YA232)2-1

CONTENTS

SEMICONDUCTOR SHAPES 2-2

BLOCK DIAGRAM 2-3

CIRCUIT DIAGRAMS

MAIN PWB CIRCUIT DIAGRAM 2-5

CONTROL PWB CIRCUIT DIAGRAM 2-24

AMPLIFIER PWB CIRCUIT DIAGRAM 2-25

AV JACK PWB CIRCUIT DIAGRAM 2-27

LED PWB CIRCUIT DIAGRAM 2-28

NOISE FILTER PWB CIRCUIT DIAGRAM 2-28

REGULATOR PWB CIRCUIT DIAGRAM 2-29

PATTERN DIAGRAMS

MAIN PWB PATTERN 2-31

AMPLIFIER PWB PATTERN 2-33

AV JACK PWB PATTERN 2-33

LED PWB PATTERN 2-33

CONTROL PWB PATTERN 2-33

NOISE FILTER PWB PATTERN 2-34

REGULATOR PWB PATTERN 2-34

USING P.W. BOARD

P.W.B ASS'Y name	LT-30E45SJ	LT-30E45SU	LT-30E45SU/N	LT-30E45SU/Z
CONTROL P.W. BOARD	VE-20148281	←	←	←
LED P.W. BOARD	VE-20167056	←	←	←
AV JACK P.W. BOARD	VE-20185947	←	VE-20148274	VE-20185947
REGULATOR P.W. BOARD	VE-20151250	←	←	←
NOISE FILTER P.W. BOARD	VE-20154613	←	←	←
MAIN P.W. BOARD	VE-20185787	←	←	←
AMPLIFIER P.W. BOARD	VE-20154273	←	←	←

SEMICONDUCTOR SHAPES

TRANSISTOR

BOTTOM VIEW	FRONT VIEW				TOP VIEW
					CHIP TR

IC

BOTTOM VIEW	FRONT VIEW			TOP VIEW

CHIP IC

TOP VIEW	

BLOCK DIAGRAM

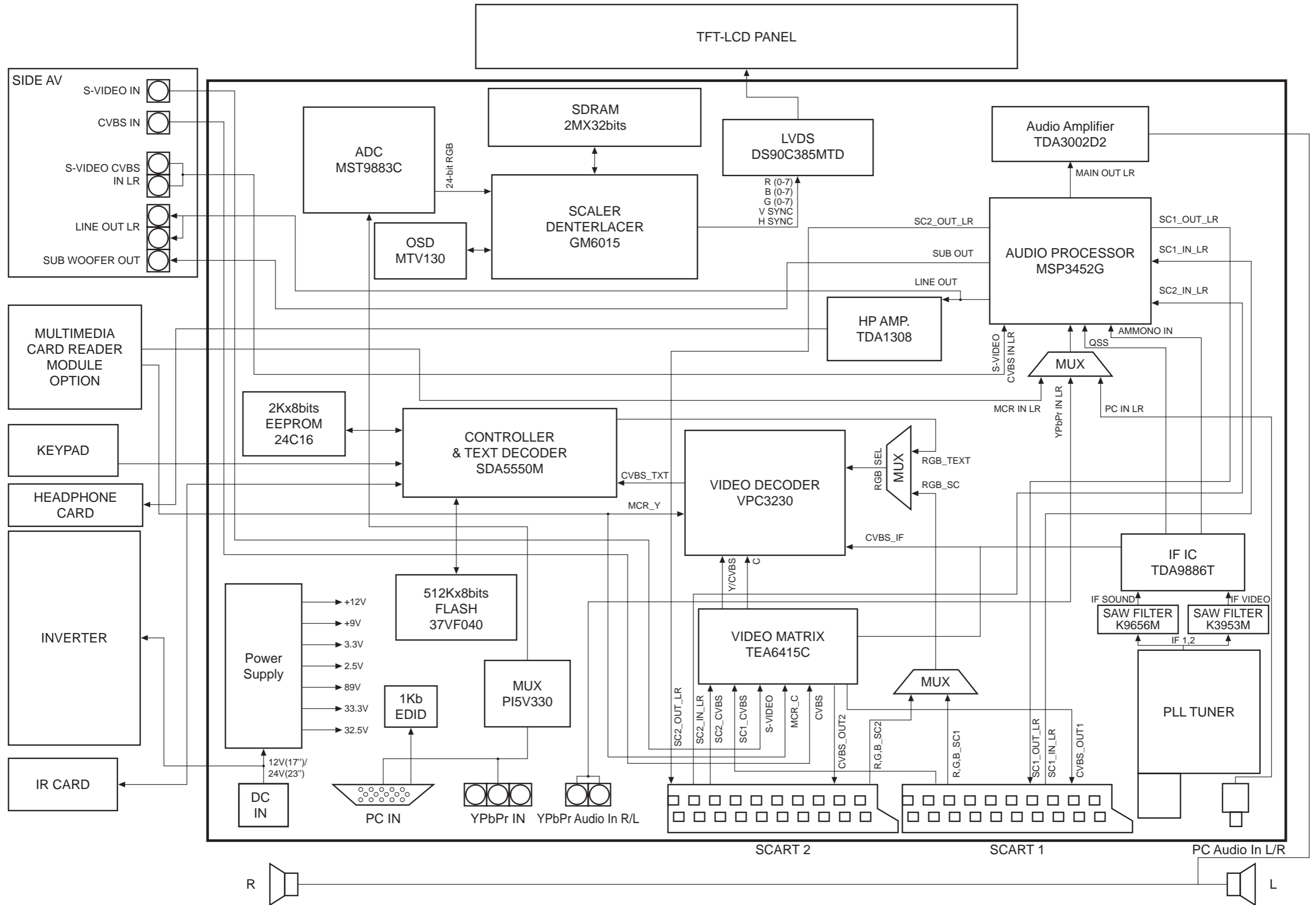

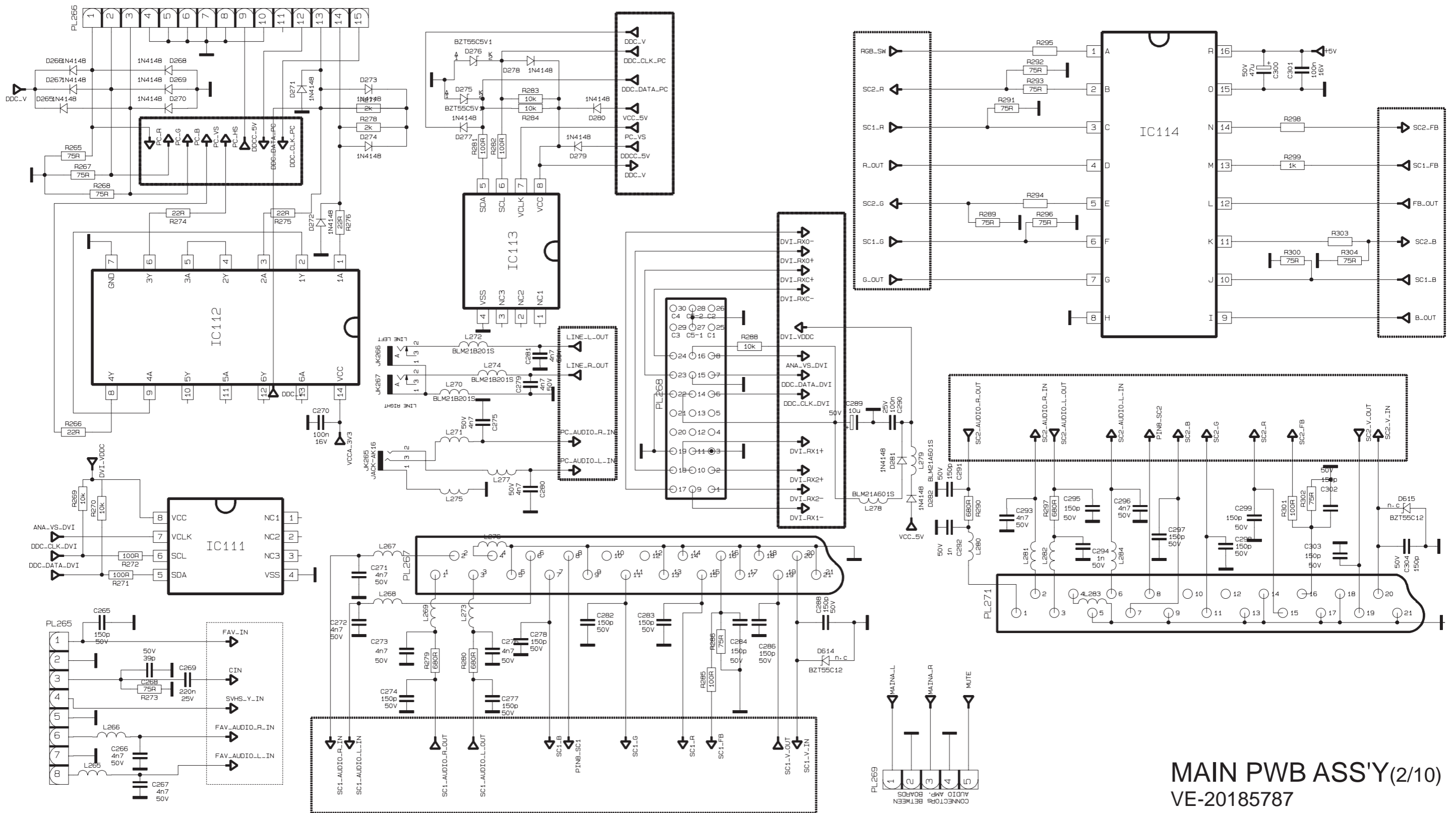

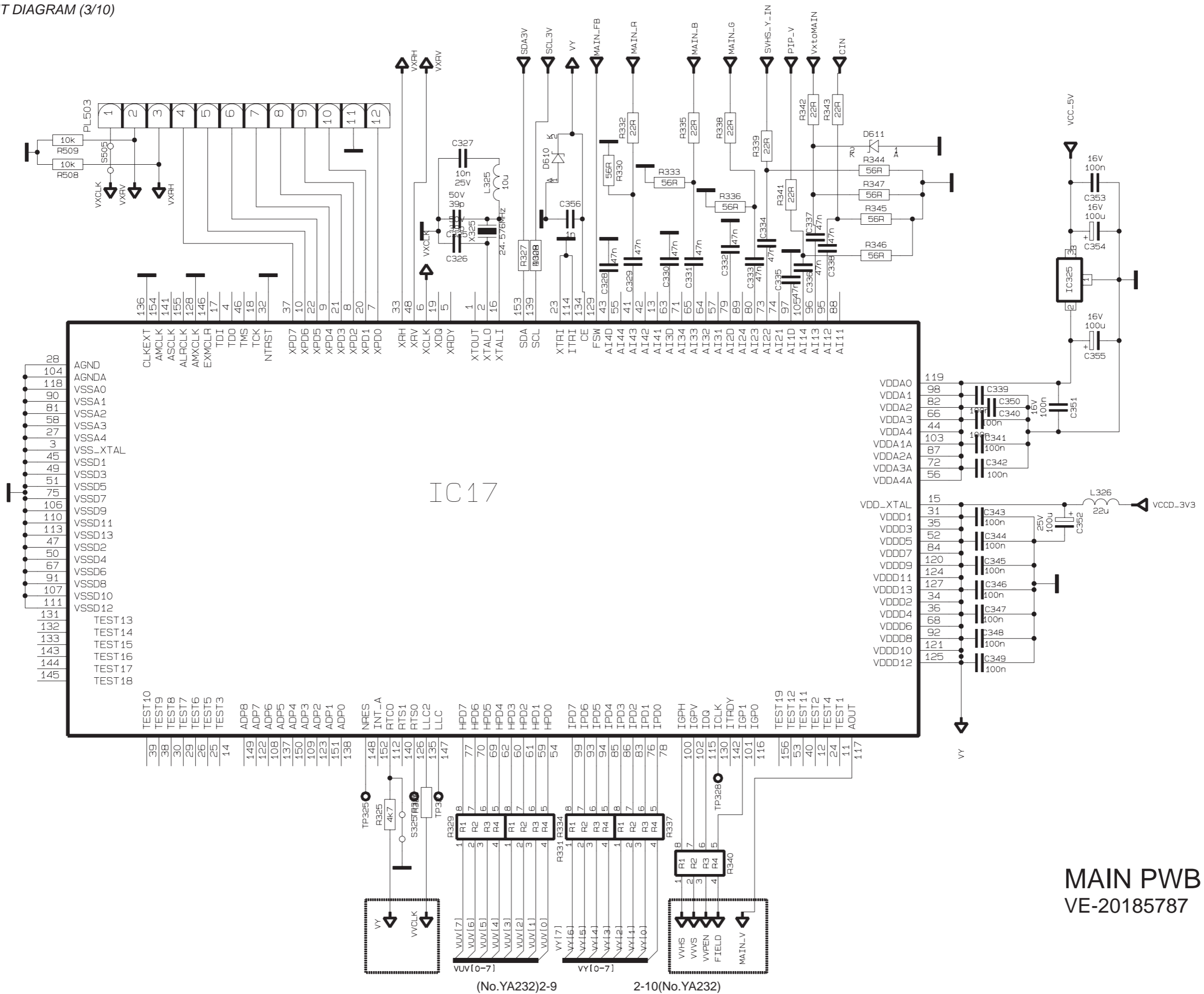

IC17

(No.YA232)2-9

2-10(No.YA232)

MAIN PWB CIRCUIT DIAGRAM (4/10)

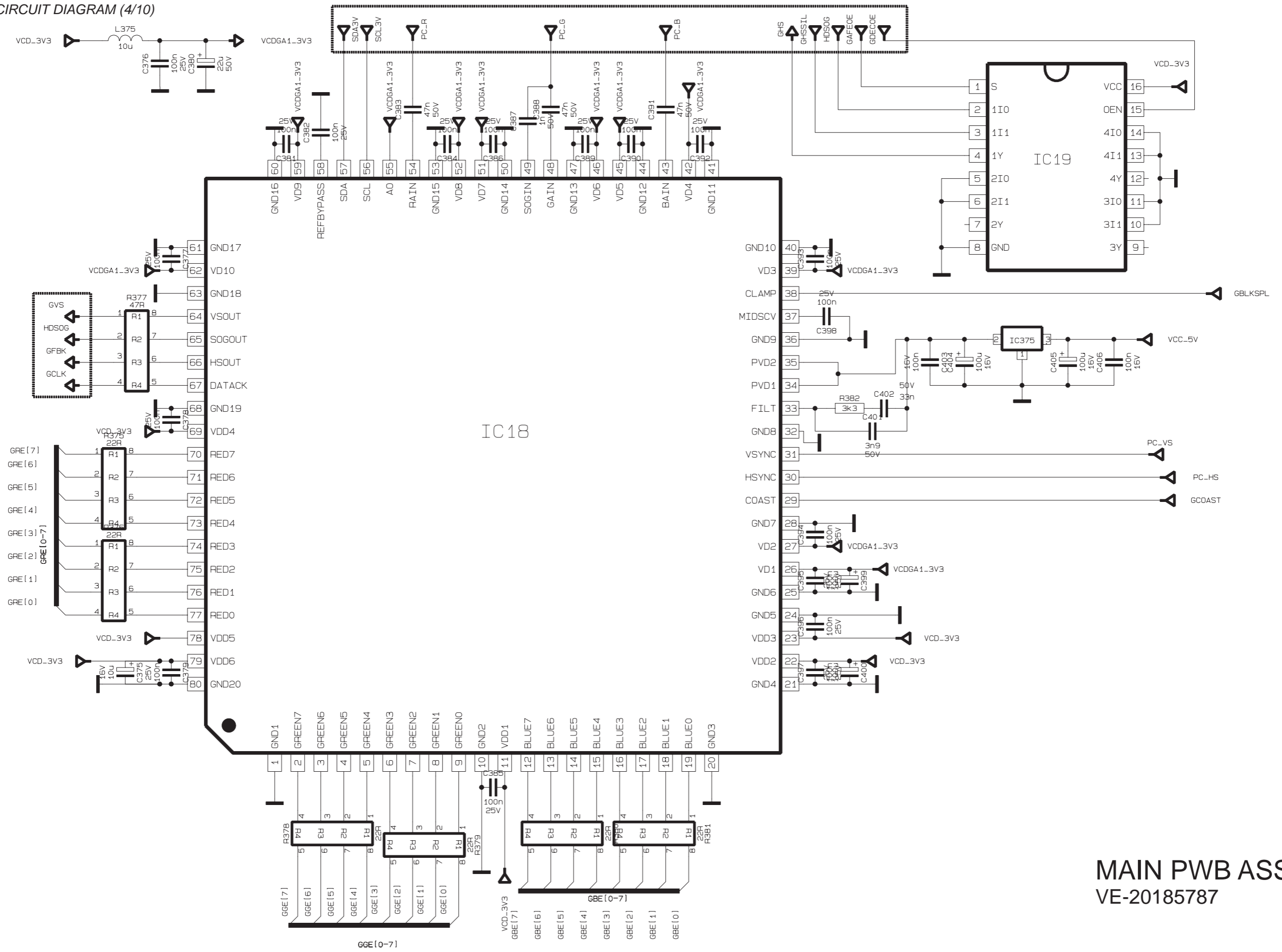

MAIN PWB ASS'Y(4/10)
VE-20185787

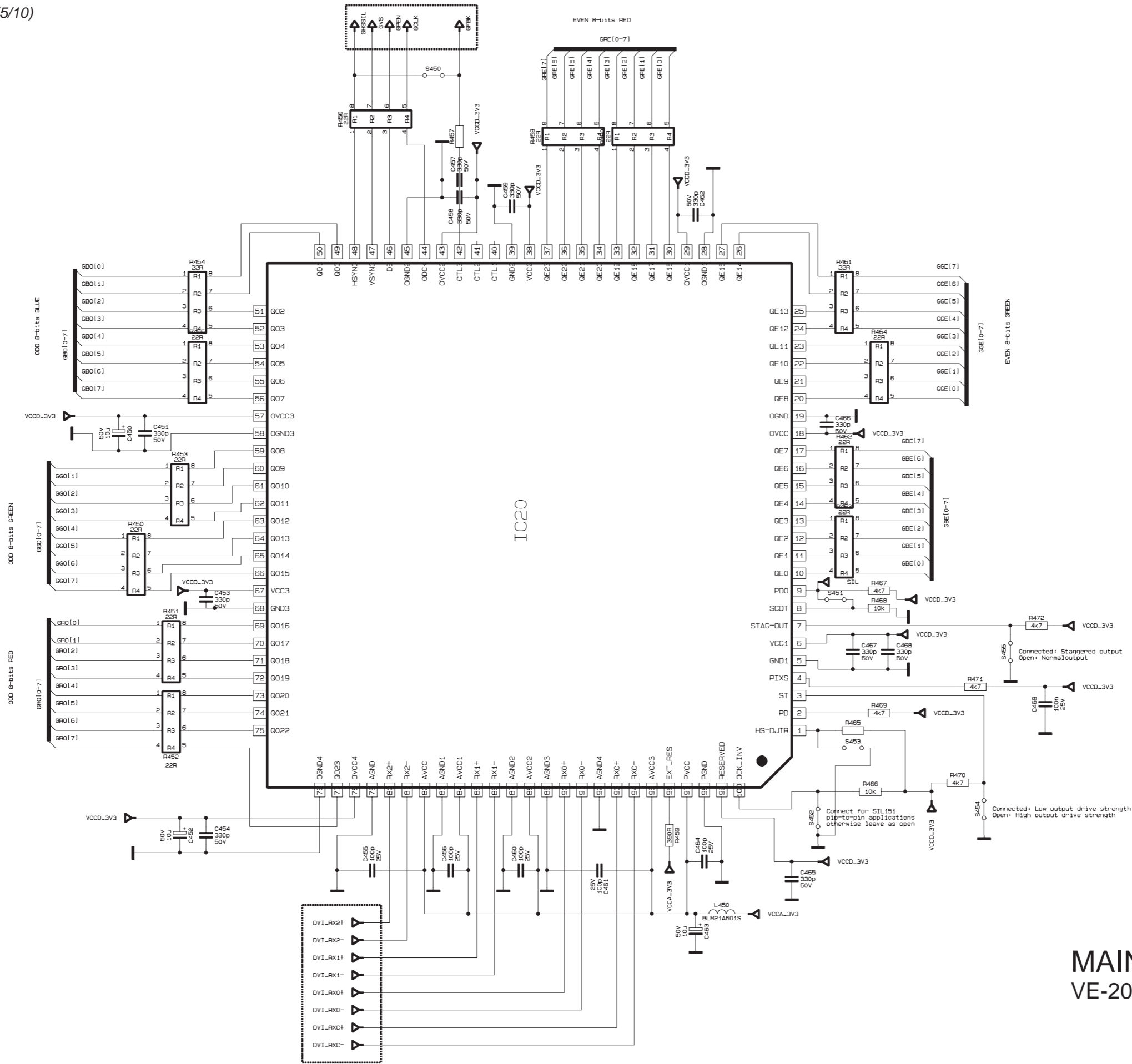

NOTE : Refer to the part list for the part number of IC24.

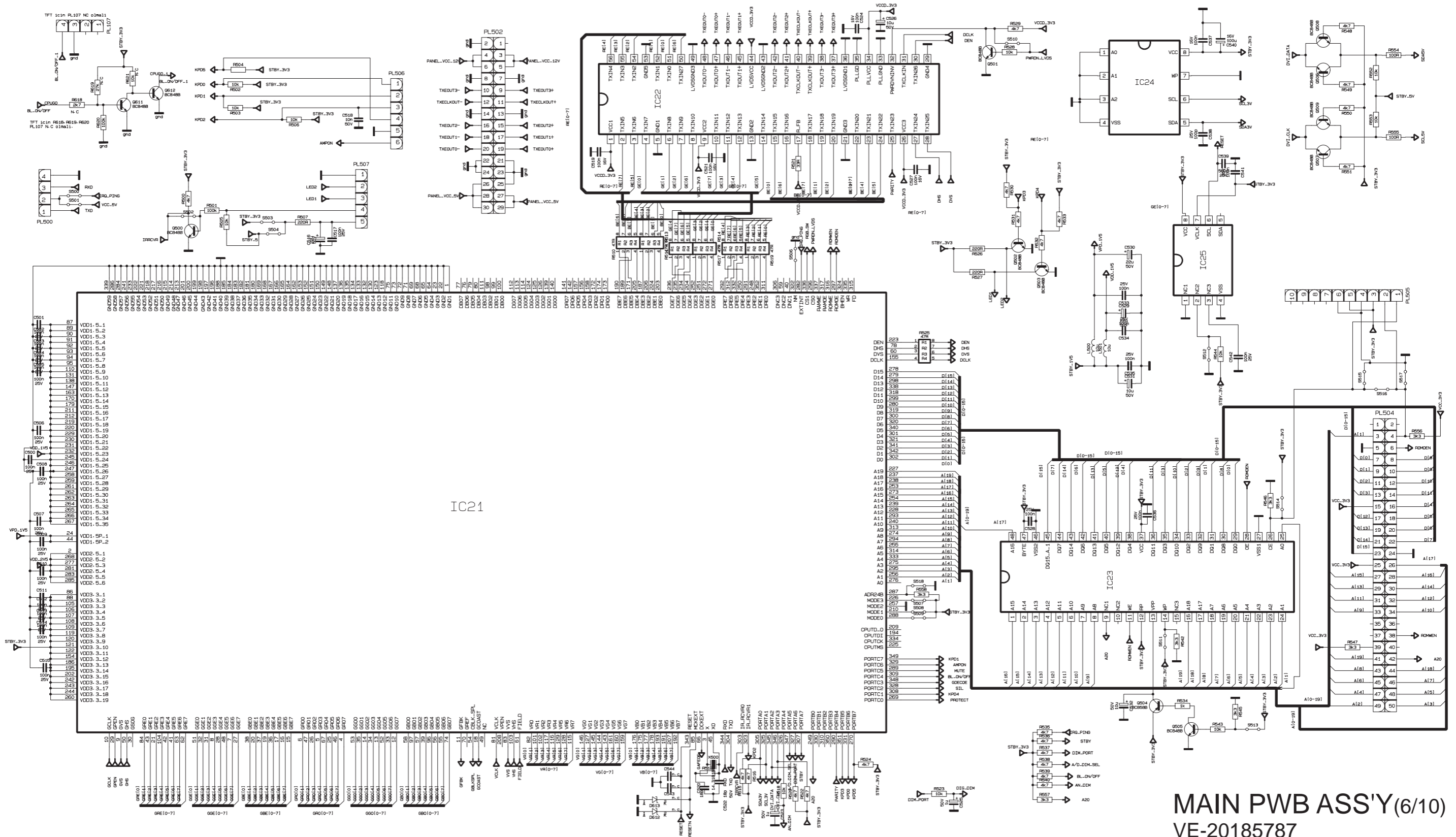

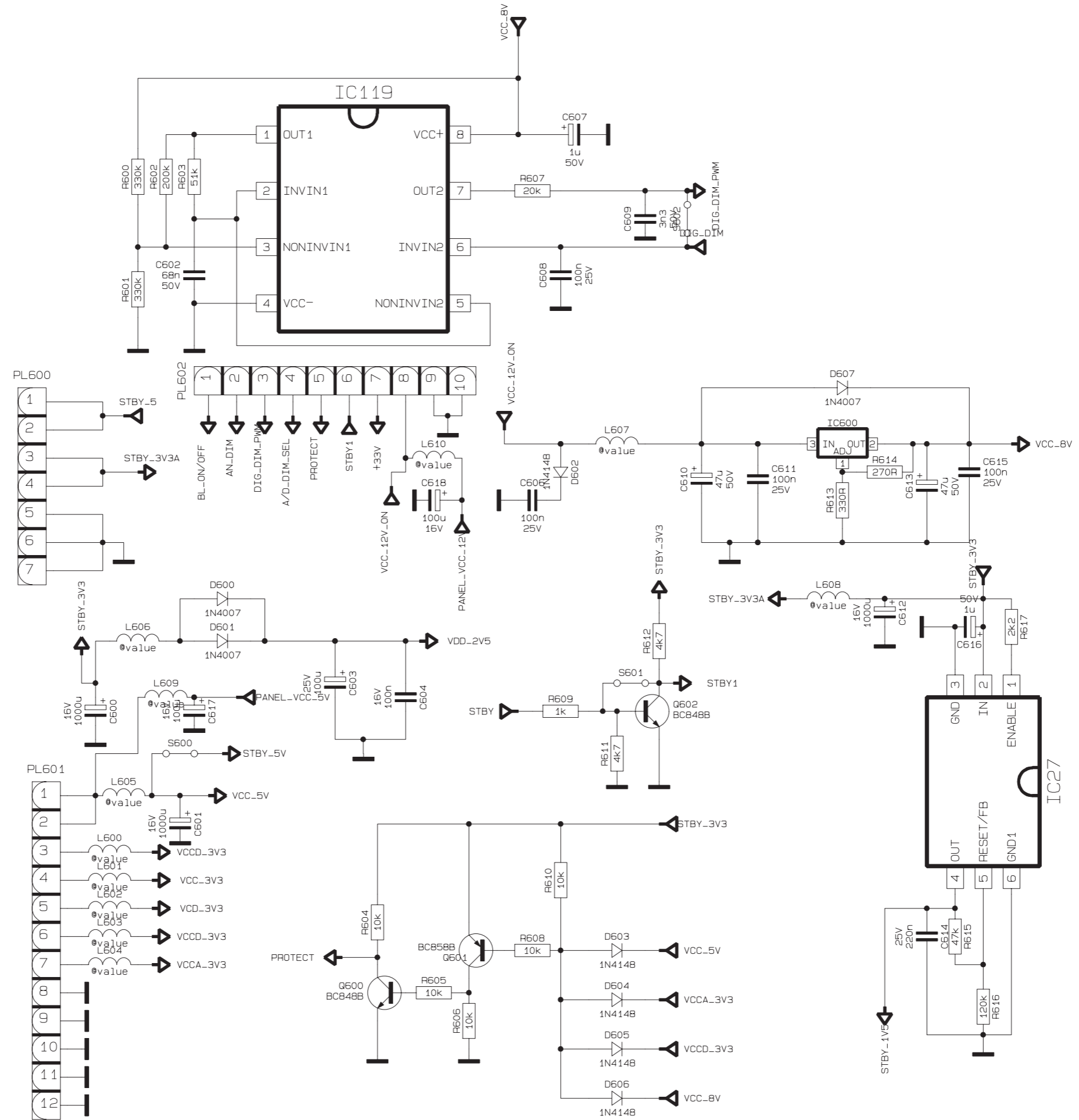

(No.YA232)2-17

2-18(No.YA232)

MAIN PWB ASS'Y(7/10)
VE-20185787

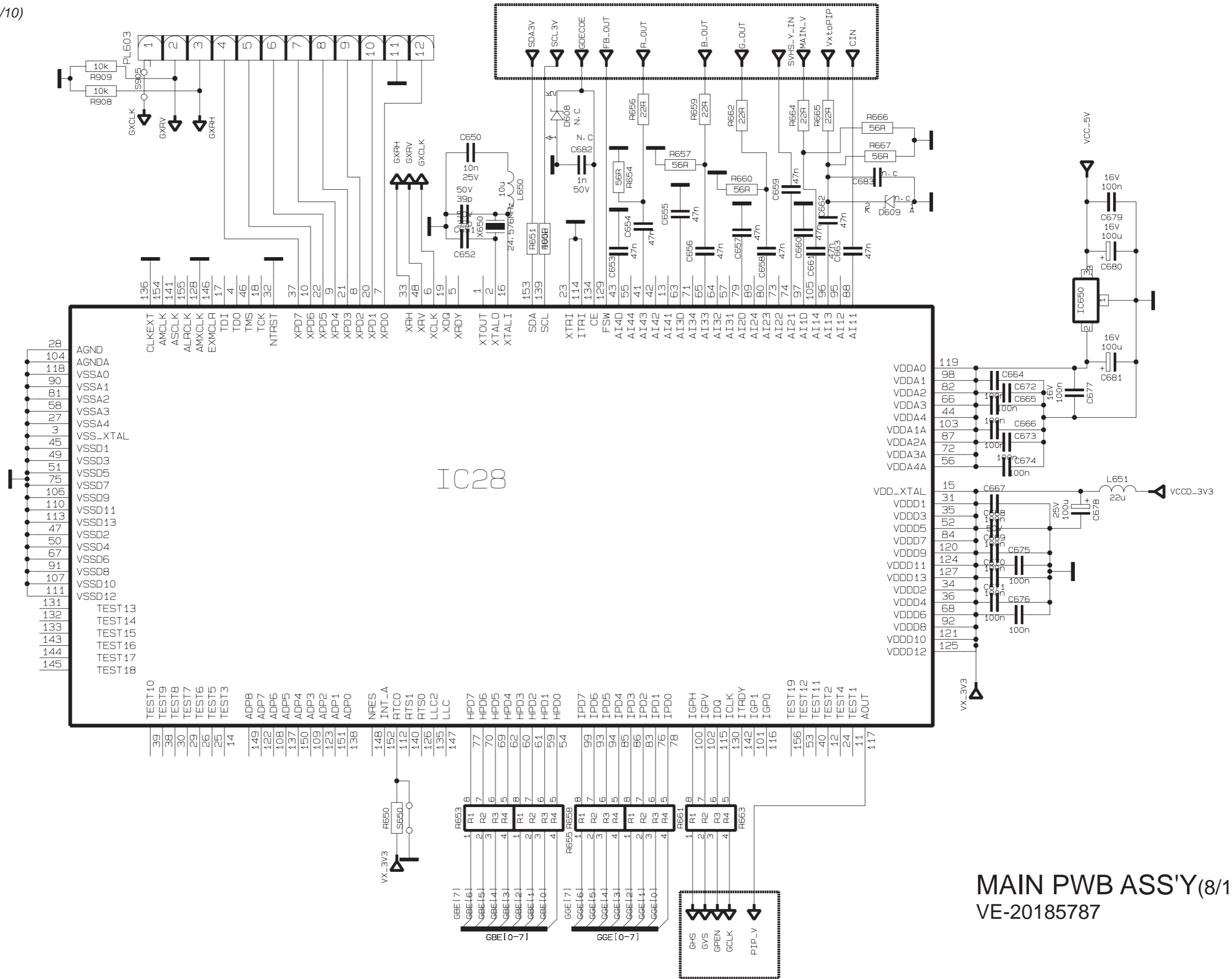

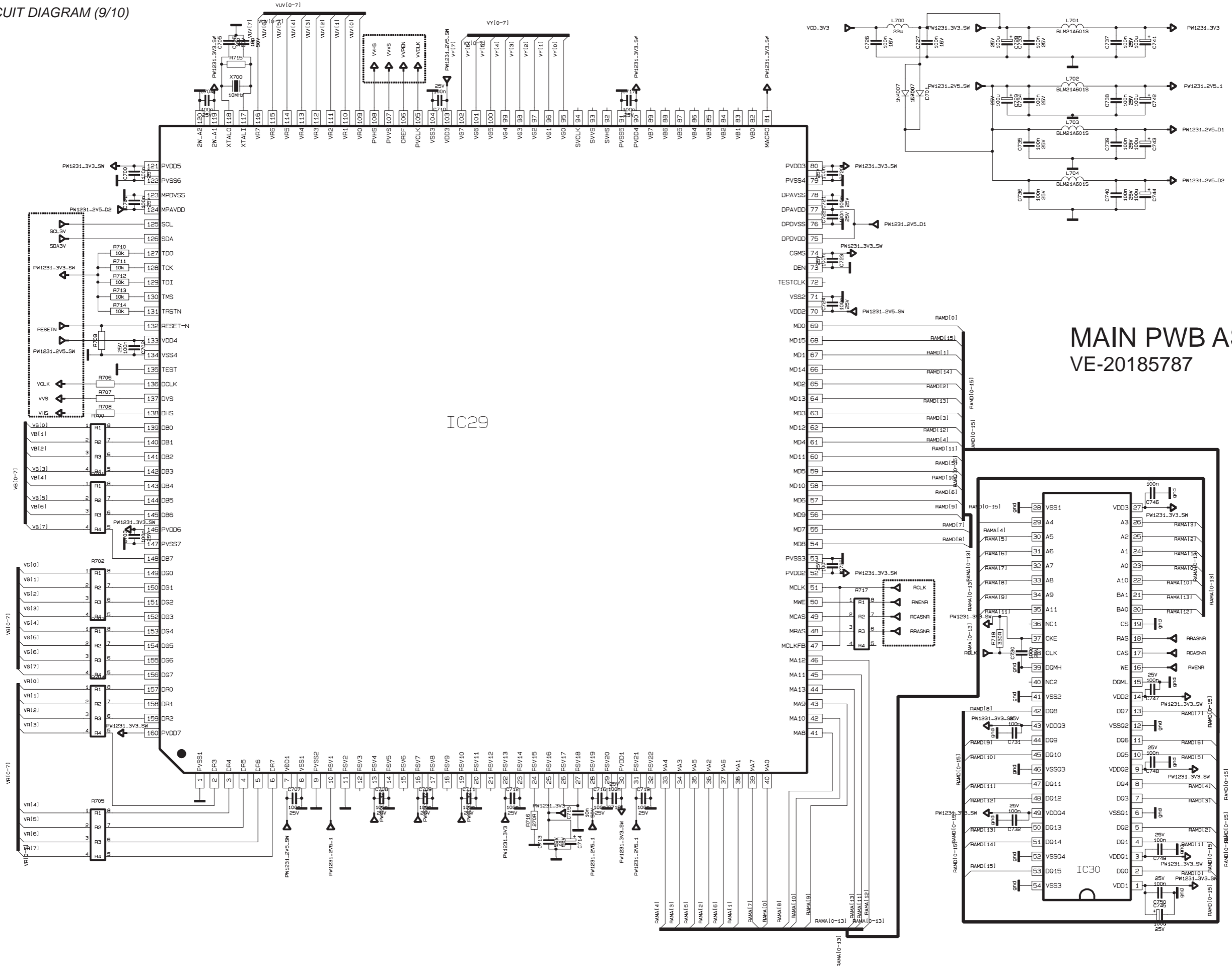

MAIN PWB ASS'Y(9/10)
VE-20185787

MAIN PWB CIRCUIT DIAGRAM (10/10)

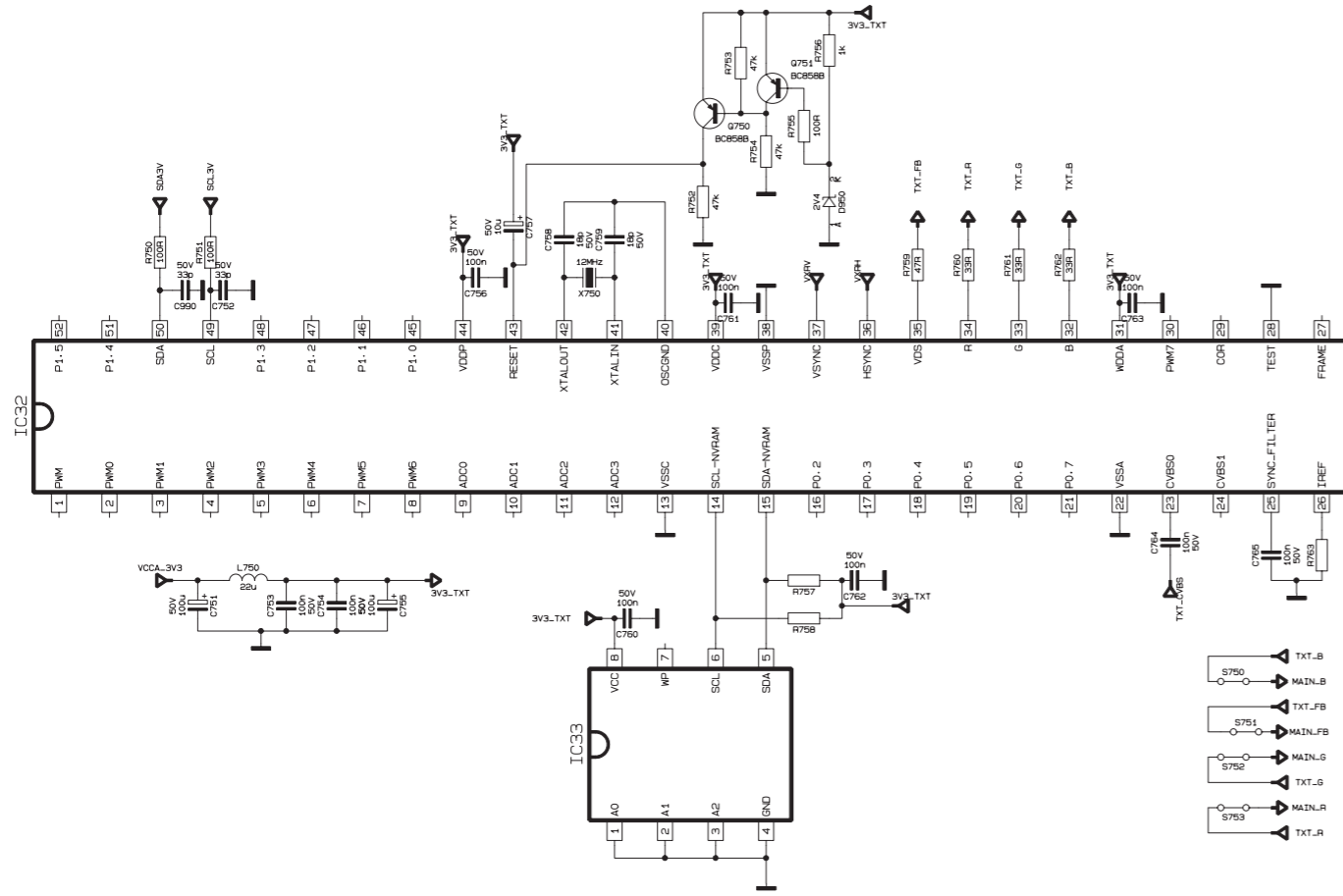

MAIN PWB ASS'Y(10/10)
VE-20185787

NOTE : Refer to the part list for the part number of IC33.

CONTROL PWB CIRCUIT DIAGRAM

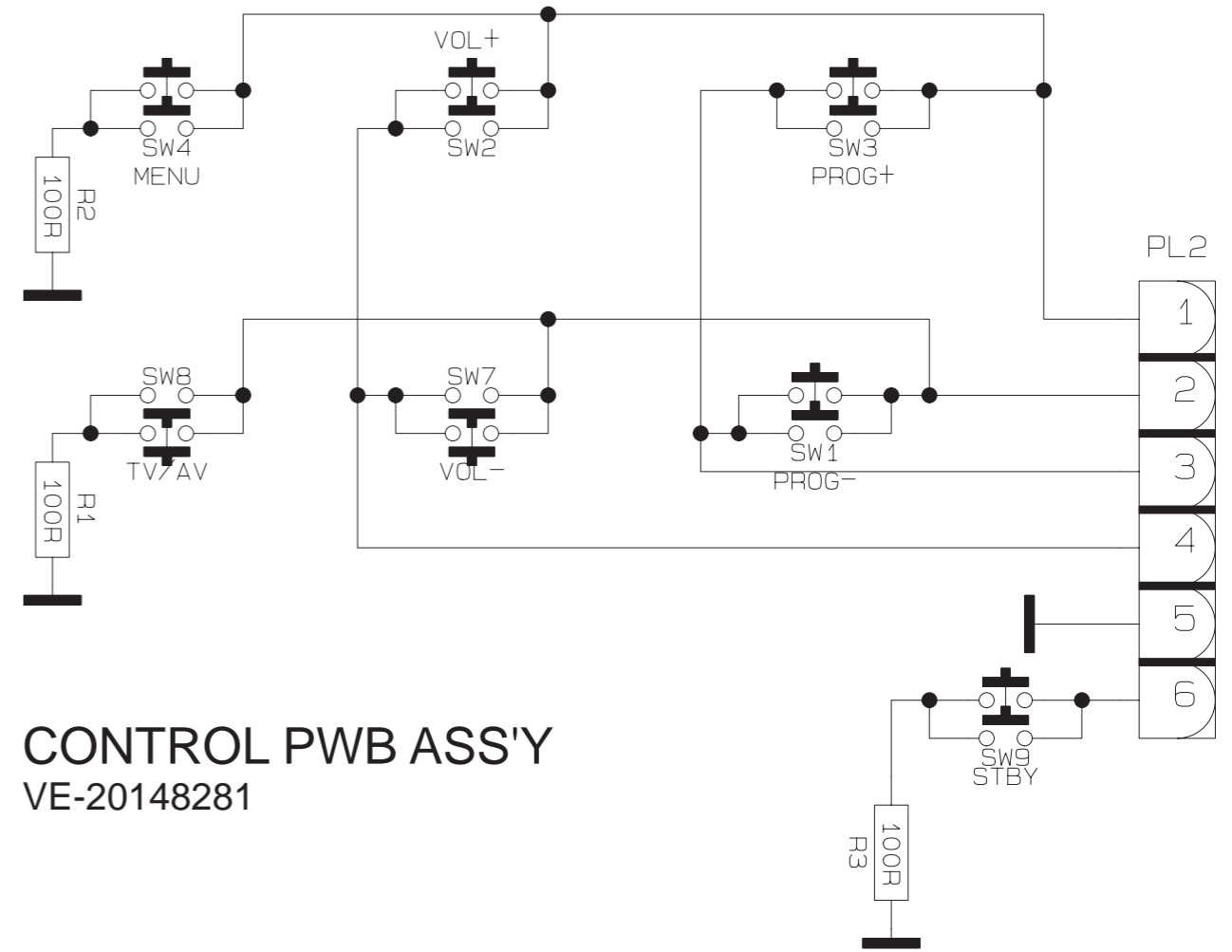

CONTROL PWB ASS'Y
VE-20148281

AMPLIFIER PWB CIRCUIT DIAGRAM

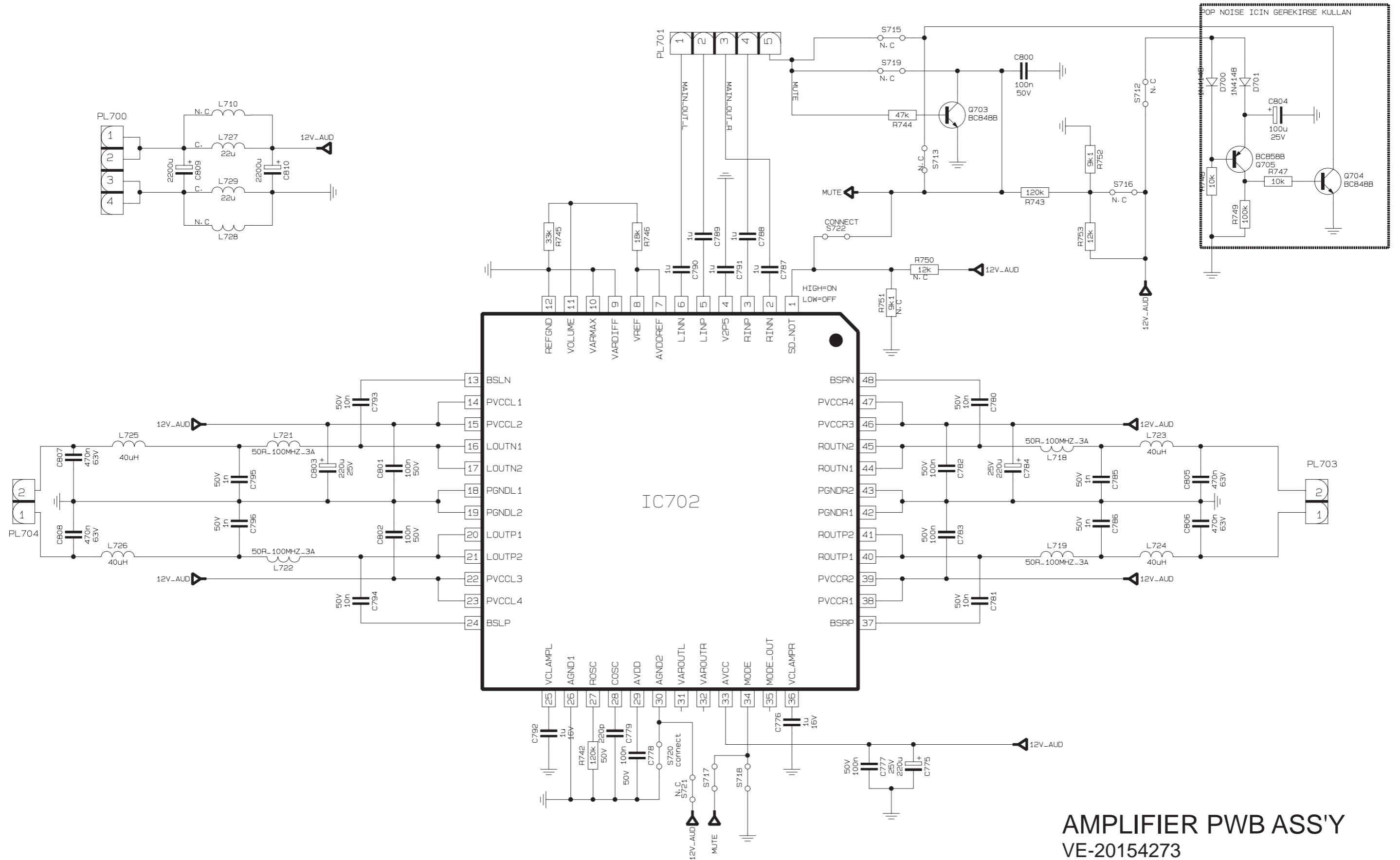

AV JACK PWB CIRCUIT DIAGRAM

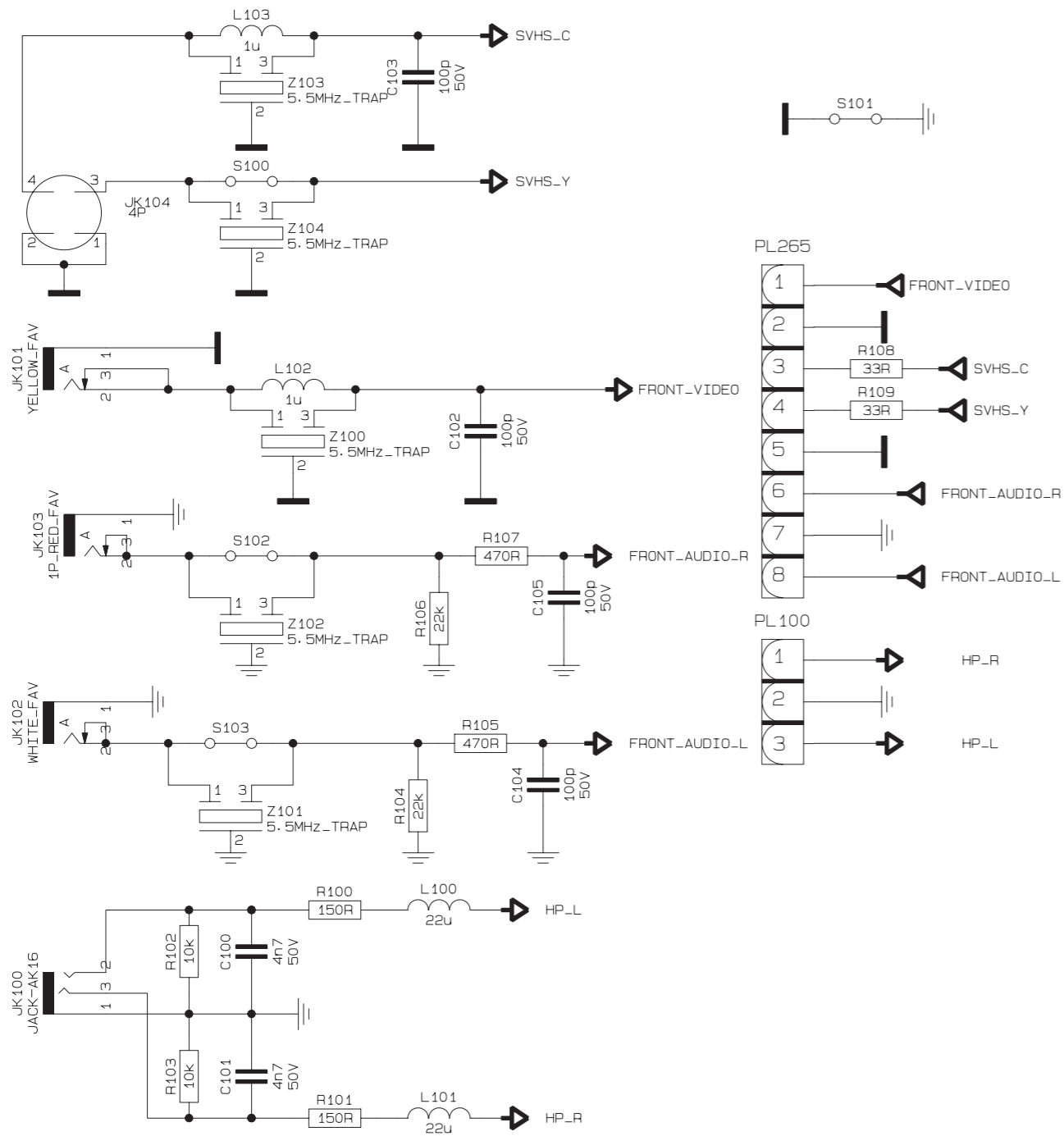

AV JACK PWB ASS'Y

VE-20185947 [LT-30E45SJ,LT-30E45SU, LT-30E45SU/Z]
 VE-20148274 [LT-30E45SU/N]

LED PWB CIRCUIT DIAGRAM

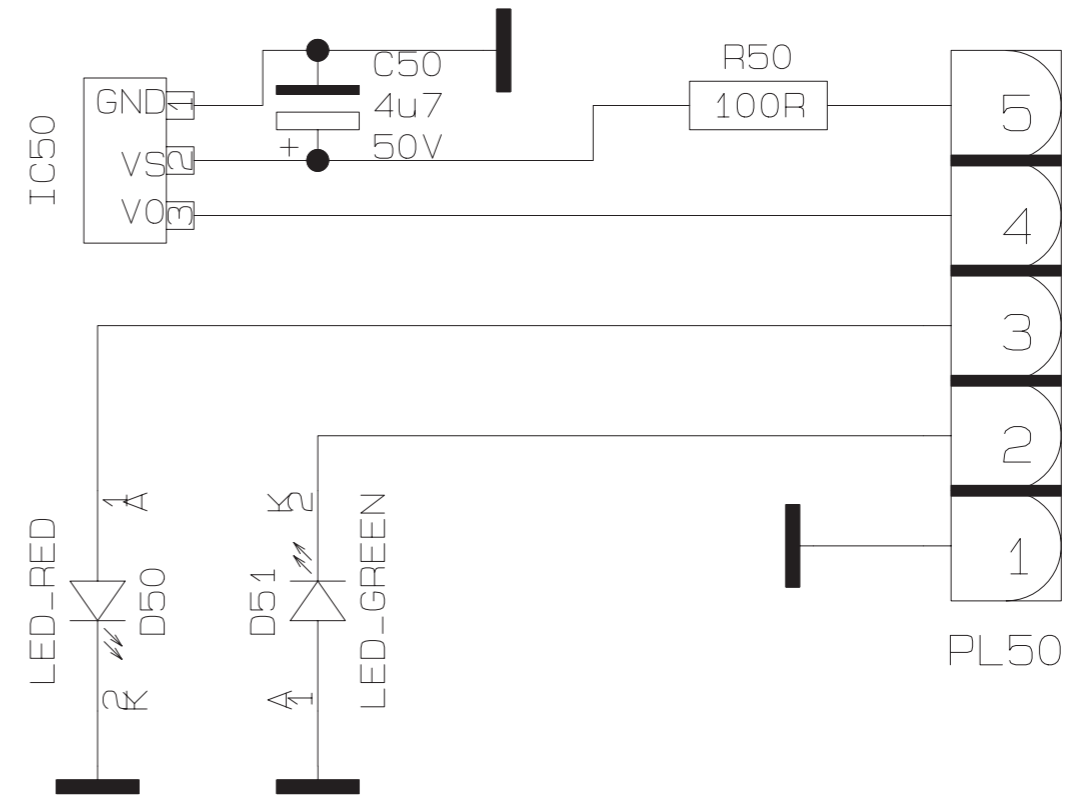

LED PWB ASS'Y

VE-20167056

NOISE FILTER PWB CIRCUIT DIAGRAM

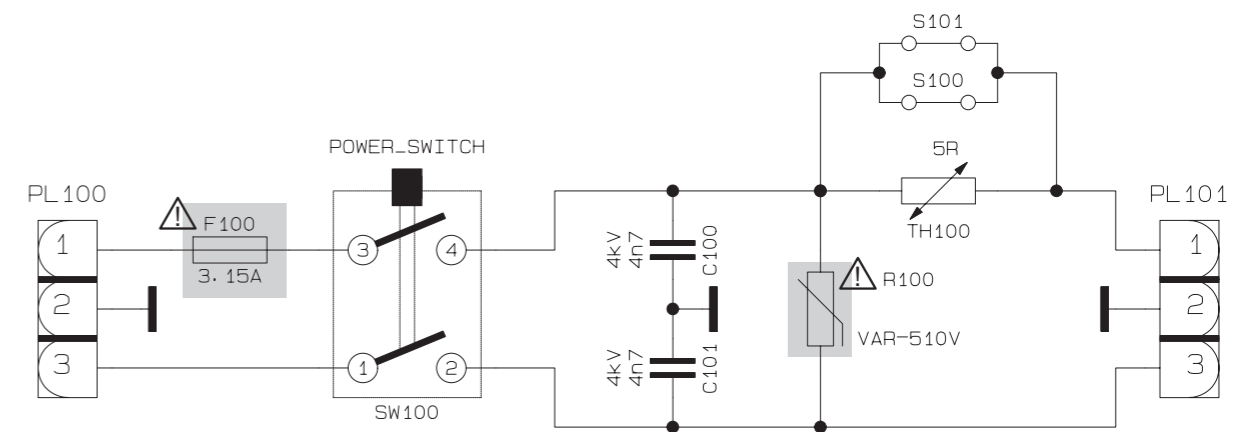

NOISE FILTER PWB ASS'Y

VE-20154613

REGULATOR PWB CIRCUIT DIAGRAM

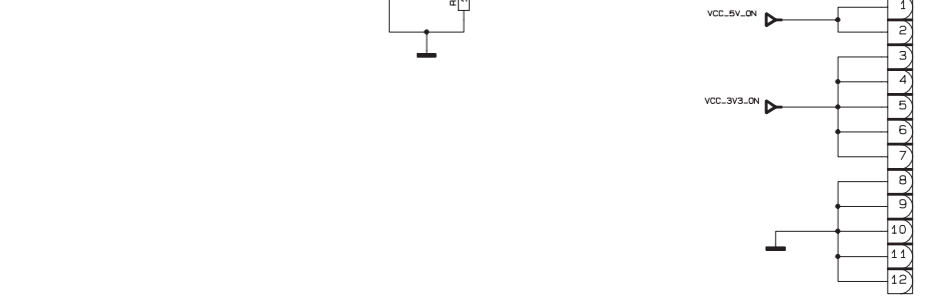
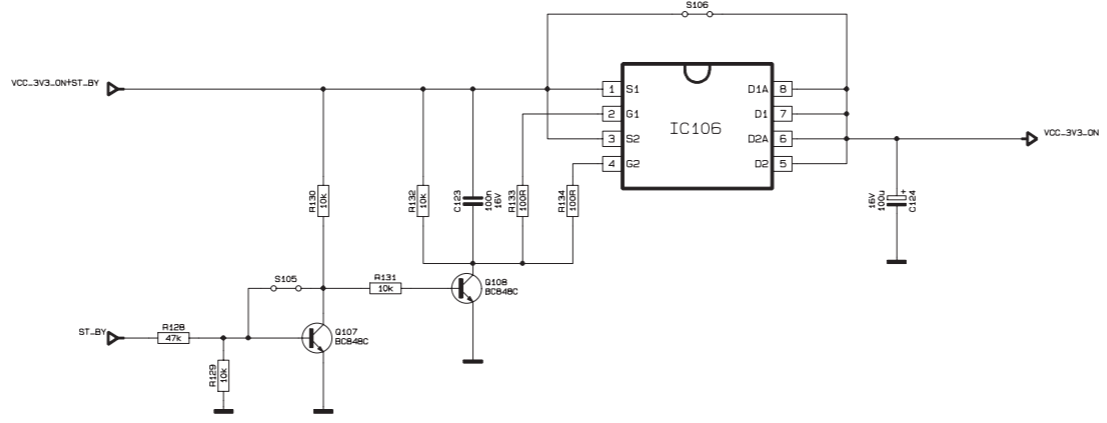
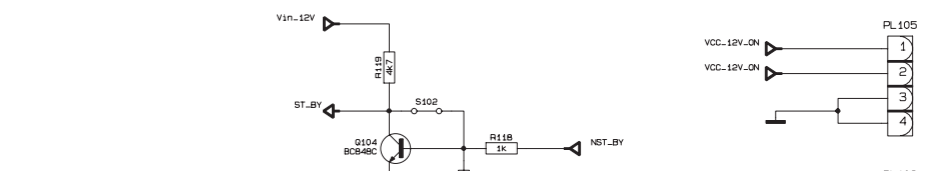
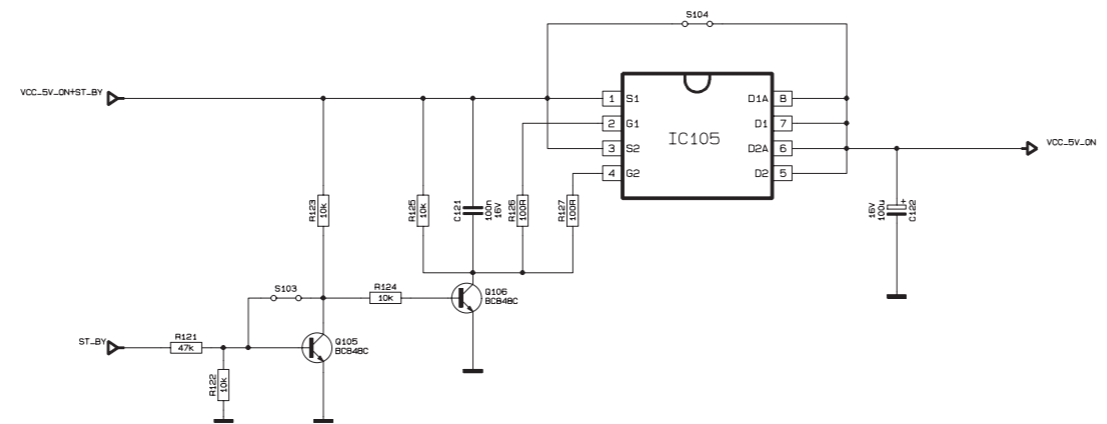
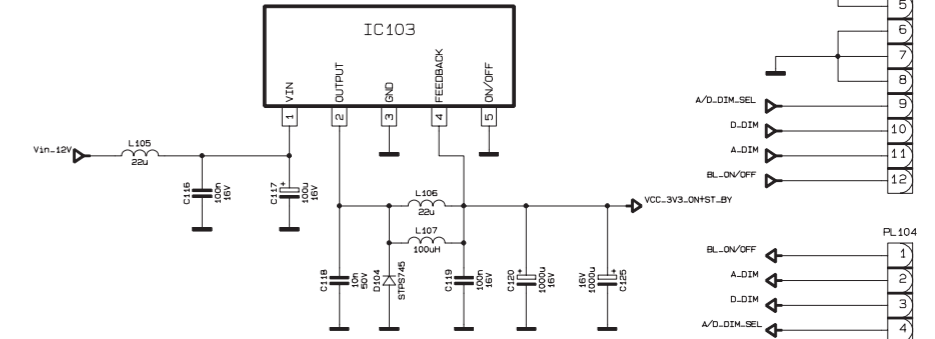
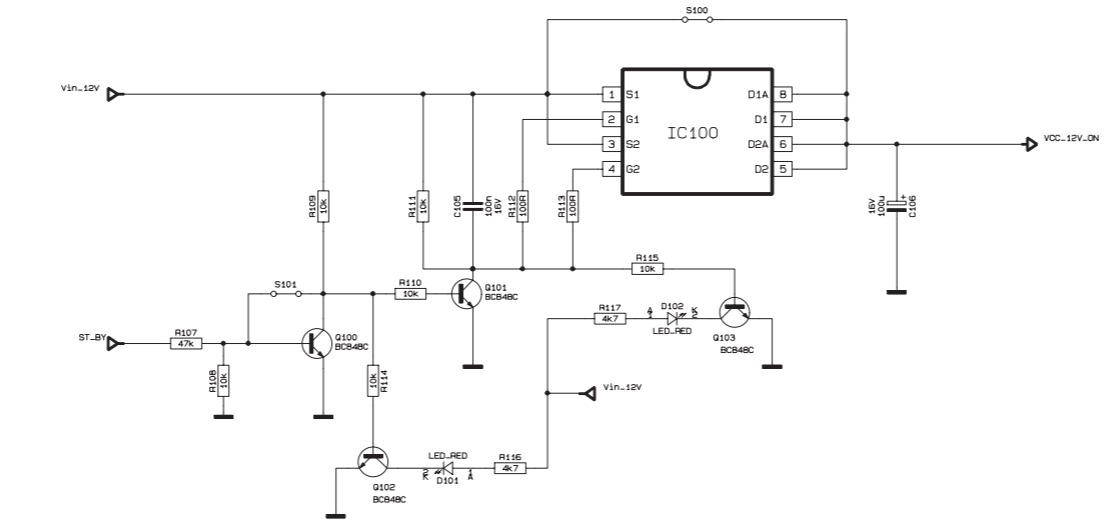
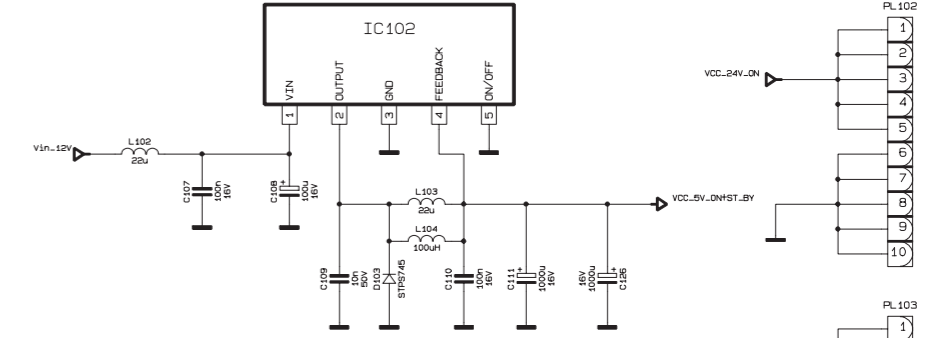
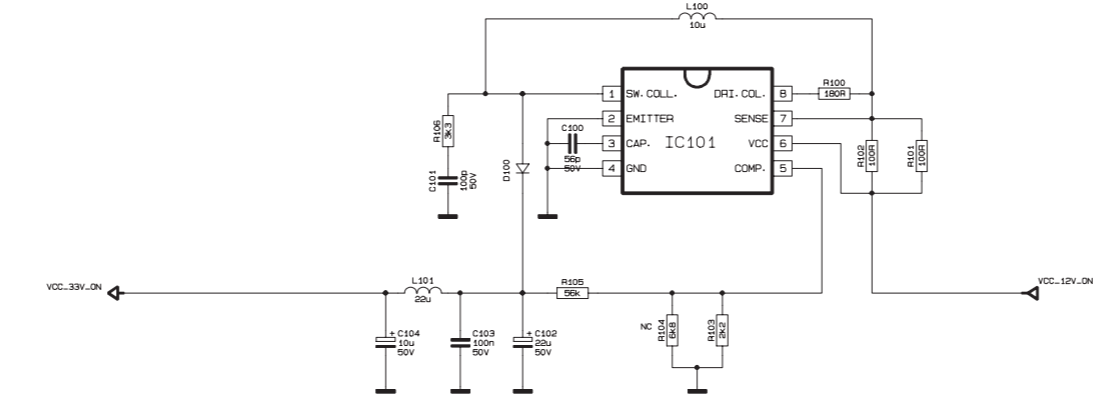
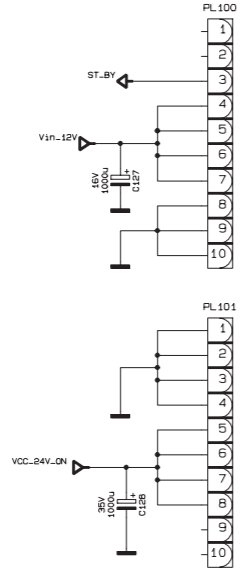

(No.YA232)2-29 2-30(No.YA232)

REGULATOR PWB ASS'Y
VE-20151250

PATTERN DIAGRAMS

MAIN PWB PATTERN

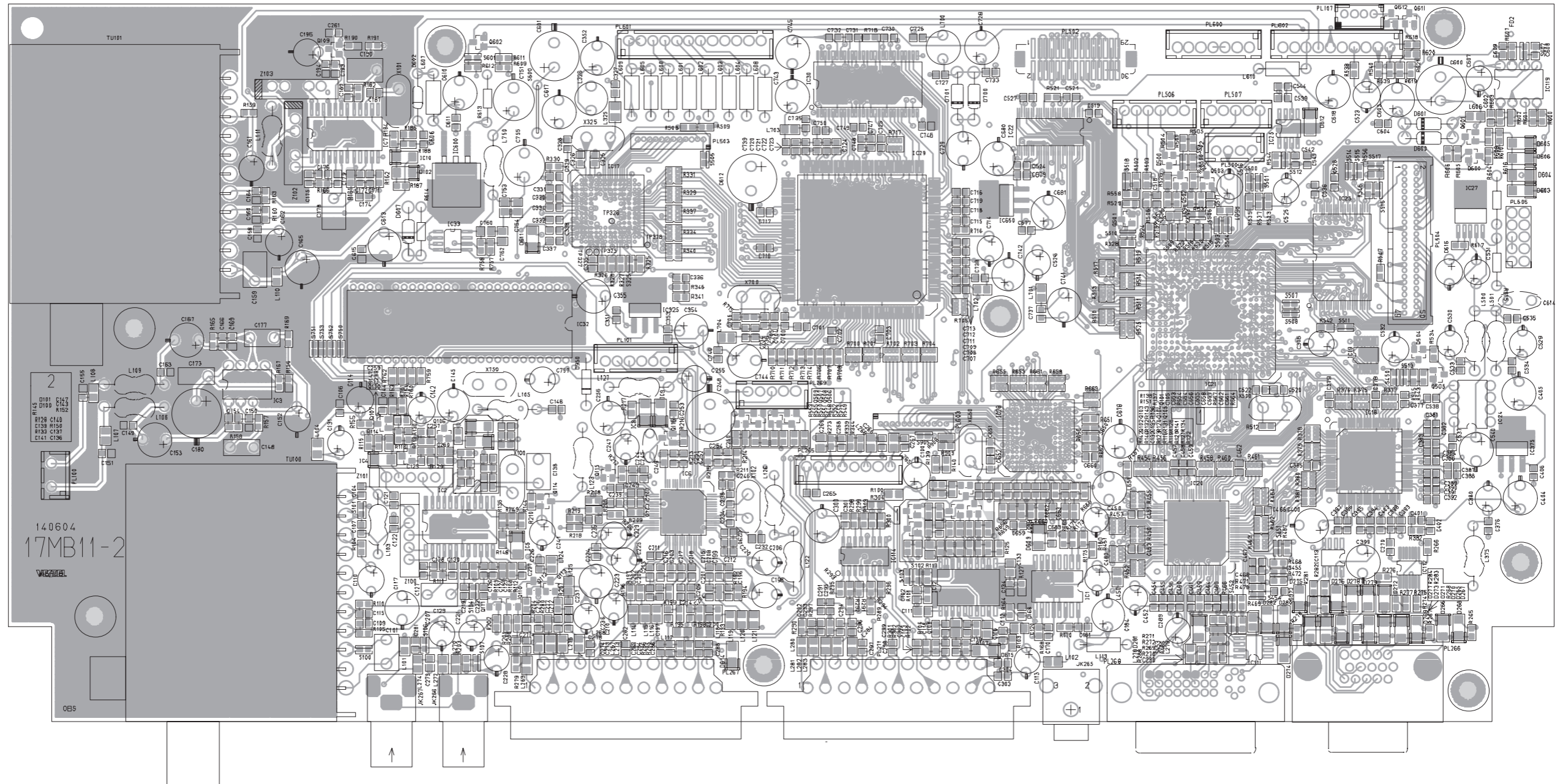

AMPLIFIER PWB PATTERN
[SOLDER SIDE]

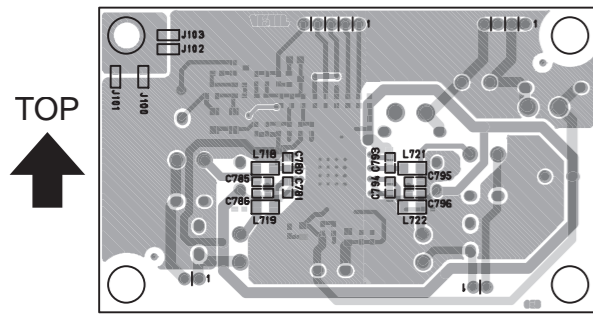

AMPLIFIER PWB PATTERN
[PARTS SIDE]

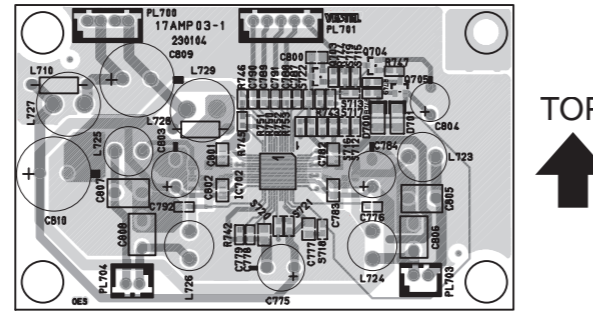

NOISE FILTER PWB PATTERN

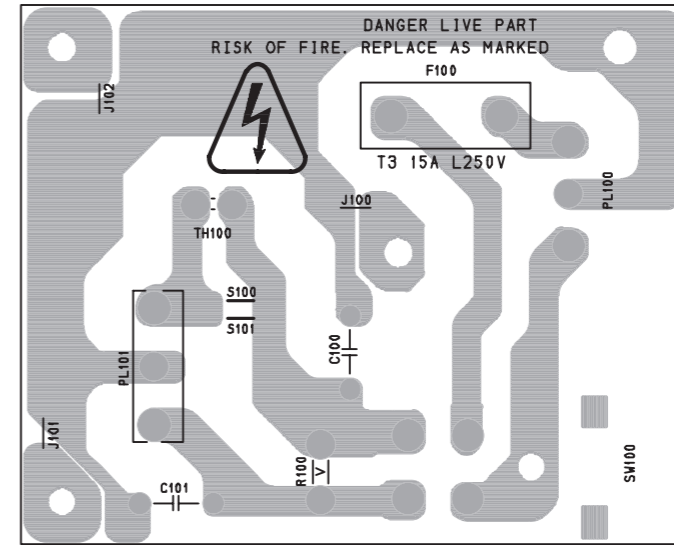

AV JACK PWB PATTERN

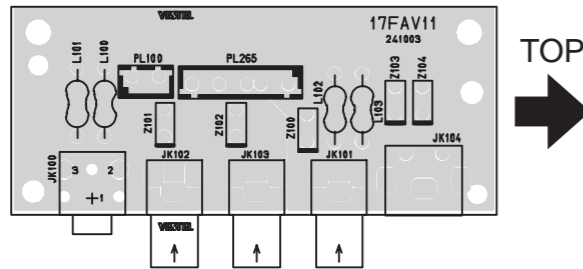

LED PWB PATTERN

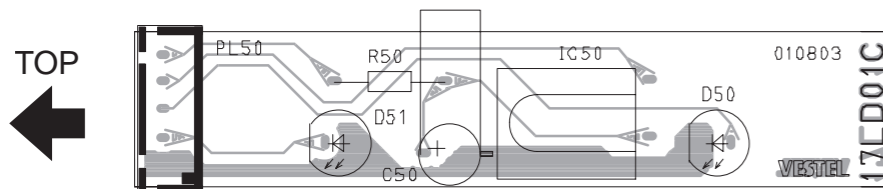

CONTROL PWB PATTERN

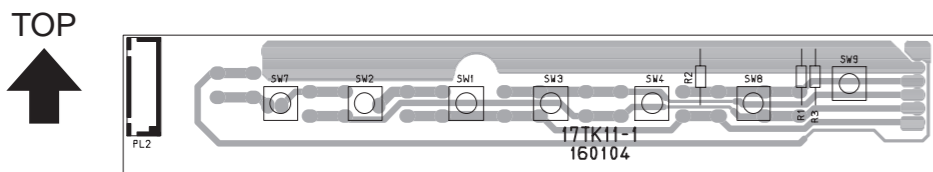

REGULATOR PWB PATTERN [SOLDER SIDE]

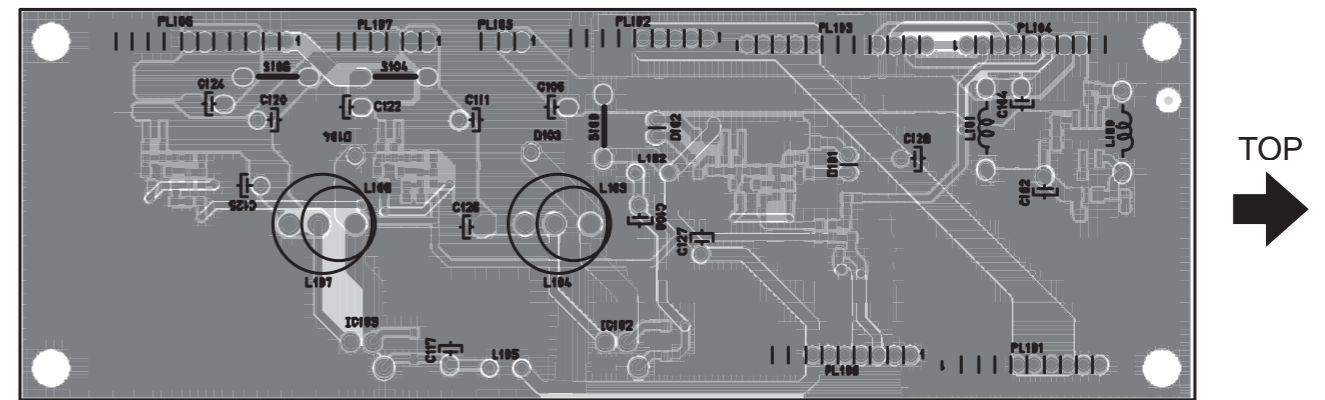

REGULATOR PWB PATTERN [PARTS SIDE]

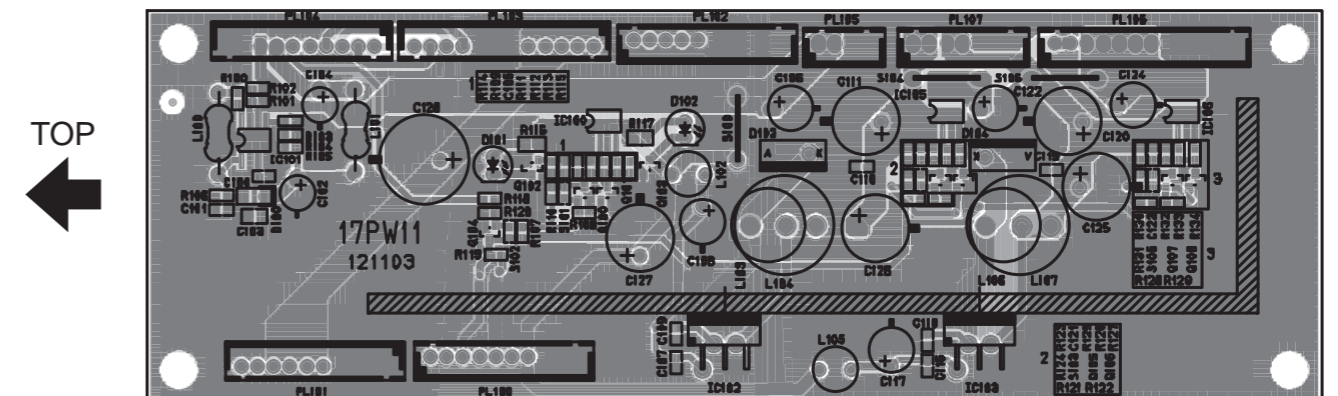

PARTS LIST

CAUTION

- The parts identified by the Δ symbol are important for the safety . Whenever replacing these parts, be sure to use specified ones to secure the safety.
- The parts not indicated in this Parts List and those which are filled with lines --- in the Parts No. columns will not be supplied.
- P.W. BOARD Ass'y will not be supplied, but those which are filled with the Parts No. in the Parts No. columns will be supplied.

ABBREVIATIONS OF RESISTORS, CAPACITORS AND TOLERANCES

RESISTORS		CAPACITORS	
CR	Carbon Resistor	C CAP.	Ceramic Capacitor
FR	Fusible Resistor	E CAP.	Electrolytic Capacitor
PR	Plate Resistor	M CAP.	Mylar Capacitor
VR	Variable Resistor	CH CAP.	Chip Capacitor
HV R	High Voltage Resistor	HV CAP.	High Voltage Capacitor
MF R	Metal Film Resistor	MF CAP.	Metalized Film Capacitor
MG R	Metal Glazed Resistor	MM CAP.	Metalized Mylar Capacitor
MP R	Metal Plate Resistor	MP CAP.	Metalized Polystyrol Capacitor
OM R	Metal Oxide Film Resistor	PP CAP.	Polypropylene Capacitor
CMF R	Coating Metal Film Resistor	PS CAP.	Polystyrol Capacitor
UNF R	Non-Flammable Resistor	TF CAP.	Thin Film Capacitor
CH V R	Chip Variable Resistor	MPP CAP.	Metalized Polypropylene Capacitor
CH MG R	Chip Metal Glazed Resistor	TAN. CAP.	Tantalum Capacitor
COMP. R	Composition Resistor	CH C CAP.	Chip Ceramic Capacitor
LPTC R	Linear Positive Temperature Coefficient Resistor	BP E CAP.	Bi-Polar Electrolytic Capacitor
		CH AL E CAP.	Chip Aluminum Electrolytic Capacitor
		CH AL BP CAP.	Chip Aluminum Bi-Polar Capacitor
		CH TAN. E CAP.	Chip Tantalum Electrolytic Capacitor
		CH AL BP E CAP.	Chip Tantalum Bi-Polar Electrolytic Capacitor

RESISTORS									
F	G	J	K	M	N	R	H	Z	P
±1%	±2%	±5%	±10%	±20%	±30%	+30% -10%	+50% -10%	+80% -20%	+100% -0%

CONTENTS

USING P.W. BOARD & REMOTE CONTROL UNIT	3-2
EXPLODED VIEW PARTS LIST	3-2
PRINTED WIRING BOARD PARTS LIST [LT-30E45SJ, LT-30E45SU, LT-30E45SU/Z]	3-4
PRINTED WIRING BOARD PARTS LIST [LT-30E45SU/N]	3-11
PACKING PARTS LIST	3-18

USING P.W. BOARD & REMOTE CONTROL UNIT

P.W.B ASS'Y	LT-30E45SJ	LT-30E45SU	LT-30E45SU/N	LT-30E45SU/Z
CONTROL PWB	VE-20148281	←	←	←
LED PWB	VE-20167056	←	←	←
AV JACK PWB	VE-20185947	←	VE-20148274	VE-20185947
REGURATOR PWB	VE-20151250	←	←	←
NOISE FILTER PWB	VE-20154613	←	←	←
MAIN PWB	VE-20185787	←	←	←
AMPLIFIER PWB	VE-20154273	←	←	←
REMOTE CONTROL UNIT	VE-30034032	←	←	←

EXPLODED VIEW PARTS LIST

△ Ref.No.	Part No.	Part Name	Description	Local
△ 1	VE-20180481	FRONT COVER		
2	VE-30027426	SPEAKER	8R 15W F/R 57x126MM W/O M.SHIELD(x2)	
3	VE-35009244	FOOT BOTTOM PLATE LCD 3007/08		
△ 4	VE-20185740	REAR COVER	3007/08(WO/CI)(SILV-142G/P)V.0	
5	VE-40021473	JVC MARK	JVC(W/P-SILVER-HST)(11.90mm)GRY1434	
6	VE-20185783	BUTTON FUNCTION		
7	VE-20185785	AV JACK BRACKET		
8	VE-20181362	AV BRACKET		
9	VE-20181842	POWER LED BRACKET		
10	VE-20185784	KNOB		
△ 11	VE-30026832	LCD PANEL UNIT	Inc. INVERTER UNIT	
12	VE-35004572	SCREW M4 x 18.5	(x12)	
13	VE-35003339	SCREW M4 x12	(x4)	
△ 14	VE-30028289	POWER UNIT		
△ 100	VE-20185787	MAIN PWB		
△ 101	VE-20148281	CONTROL PWB		
△ 102	VE-20167056	LED PWB		
△ 103	VE-20148274	AV JACK PWB		LT-30E45SU/N
△ 103	VE-20185947	AV JACK PWB		LT-30E45SJ,LT-30E45SU,LT-30E45SU/Z
△ 104	VE-20154273	AMPLIFIER PWB		
△ 105	VE-20154613	NOISE FILTER PWB		
△ 106	VE-20151250	REGURATOR PWB		

EXPLODED VIEW

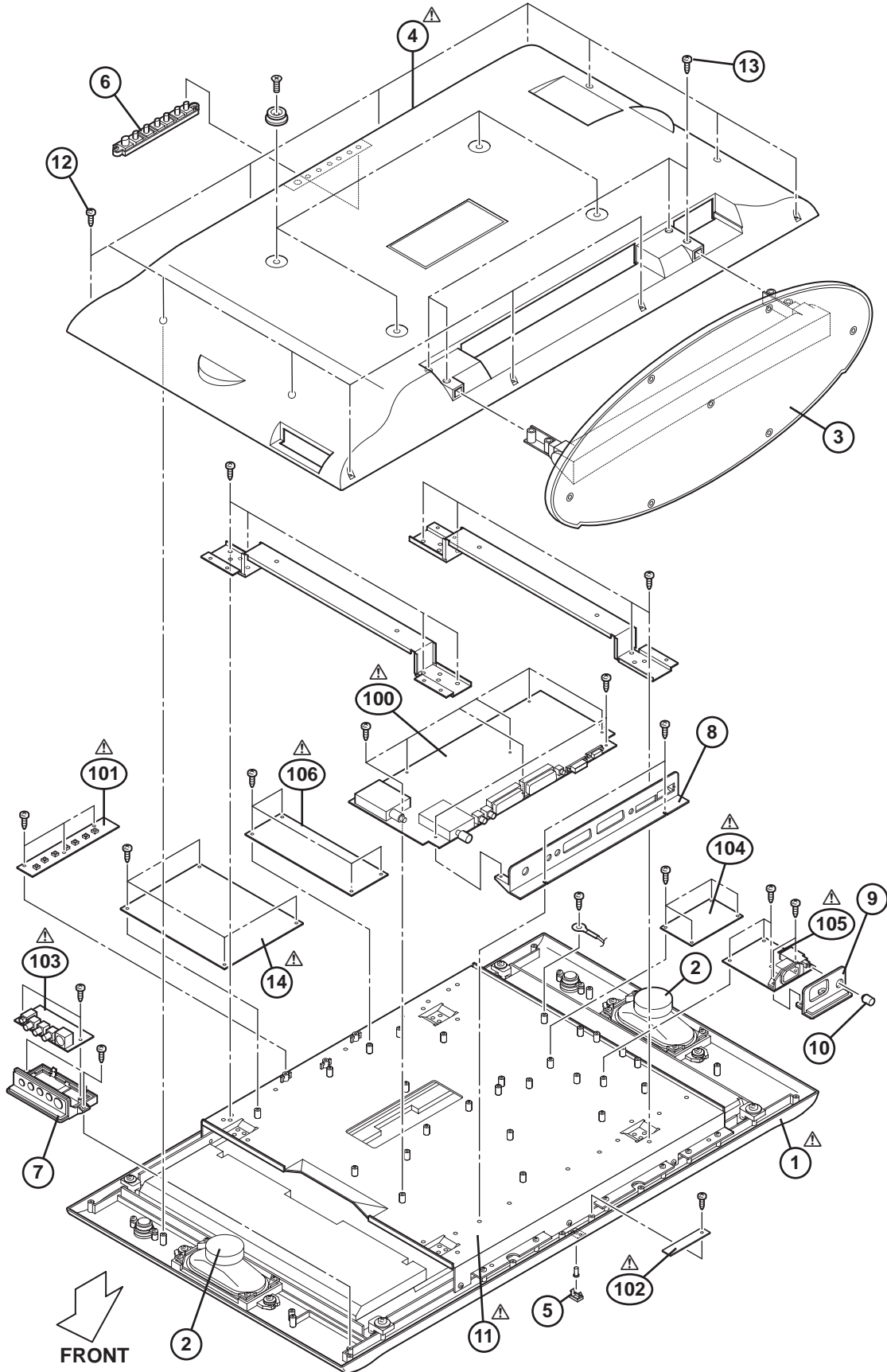

PRINTED WIRING BOARD PARTS LIST

[LT-30E45SJ, LT-30E45SU, LT-30E45SU/z]

△Ref No.	Part No.	Part Name	Description Local	△Ref No.	Part No.	Part Name	Description Local
				Q703	VE-30001457	TRANSISTOR SMD	
				Q704	VE-30001457	TRANSISTOR SMD	
				Q705	VE-30001458	TRANSISTOR SMD	
				Q750	VE-30001458	TRANSISTOR SMD	
				Q751	VE-30001458	TRANSISTOR SMD	
IC1	VE-30021628	IC		D50	VE-30001279	LED	RED/GREEN
IC1	VE-30021628	IC		D51	VE-30001279	LED	RED/GREEN
IC2	VE-30021083	TDA9886T/SO24/REEL13/N4		D100	VE-30001285	DIODE SMD	
IC3	VE-30001518	IC		D101	VE-30011601	LED	GREEN
IC4	VE-30012411	DIODE SMD		D102	VE-30010152	LED	RED
IC5	VE-30001285	DIODE SMD		D103	VE-30001313	DIODE	
IC6	VE-30018263	IC		D103	VE-30012411	DIODE SMD	
IC7	VE-30021083	TDA9886T/SO24/REEL13/N4		D104	VE-30001313	DIODE	
IC8	VE-30007761	DIODE SMD		D1XX	VE-30007763	DIODE SMD	
IC9	VE-30001285	DIODE SMD		D1XX	VE-30007763	DIODE SMD	
IC10	VE-30001285	DIODE SMD		D265	VE-30001285	DIODE SMD	
IC12	VE-30013686	IC		D266	VE-30001285	DIODE SMD	
IC17	VE-30021626	IC		D267	VE-30001285	DIODE SMD	
IC18	VE-30016822	IC		D268	VE-30001285	DIODE SMD	
IC19	VE-30020632	IC		D269	VE-30001285	DIODE SMD	
IC21	VE-30028202	IC		D270	VE-30001285	DIODE SMD	
IC22	VE-30017847	IC		D271	VE-30001285	DIODE SMD	
IC23	VE-30014162	IC		D272	VE-30001285	DIODE SMD	
IC24	VE-20185790	IC(MICOM)	(SERVICE)	D273	VE-30001285	DIODE SMD	
IC24	VE-30001468	IC		D274	VE-30001285	DIODE SMD	
IC25	VE-30019957	IC		D275	VE-30007763	DIODE SMD	
IC27	VE-30020052	IC		D276	VE-30007763	DIODE SMD	
IC28	VE-30021626	IC		D277	VE-30001285	DIODE SMD	
IC29	VE-30030108	IC		D278	VE-30001285	DIODE SMD	
IC30	VE-30014088	IC		D279	VE-30001285	DIODE SMD	
IC32	VE-30021943	IC		D280	VE-30001285	DIODE SMD	
IC33	VE-20185355	IC(MEMORY)	(SERVICE)	D2XX	VE-30007763	DIODE SMD	
IC50	VE-30001670	PREAMPLIFIER TFMS5360		D2XX	VE-30009699	DIODE SMD	
IC100	VE-30014344	TRANSISTOR		D3XX	VE-30009699	DIODE SMD	
IC101	VE-30018326	IC		D600	VE-30001329	DIODE	
IC102	VE-30023370	IC		D602	VE-30001284	DIODE	
IC103	VE-30023369	IC		D603	VE-30001285	DIODE SMD	
IC105	VE-30018029	TRANSISTOR		D604	VE-30001285	DIODE SMD	
IC106	VE-30018029	TRANSISTOR		D605	VE-30001285	DIODE SMD	
IC112	VE-30018358	IC		D606	VE-30001285	DIODE SMD	
IC113	VE-30018006	IC		D614	VE-30007763	DIODE SMD	
IC114	VE-30019372	IC		D615	VE-30007763	DIODE SMD	
IC119	VE-30001665	IC		D700	VE-30001285	DIODE SMD	
IC325	VE-30017956	IC		D700	VE-30001329	DIODE	
IC375	VE-30017956	IC		D701	VE-30001285	DIODE SMD	
IC600	VE-30007739	IC		D701	VE-30001329	DIODE	
IC650	VE-30017956	IC		D710	VE-30003720	DIODE SMD	
IC702	VE-30027663	IC		D711	VE-30003720	DIODE SMD	
				D950	VE-30001367	DIODE	
Q100	VE-30001457	TRANSISTOR SMD		C50	VE-30000413	E CAPACITOR	4.7uF 50V M
Q101	VE-30001457	TRANSISTOR SMD		C100	VE-30000345	E CAPACITOR	10uF 50V M
Q101	VE-30007798	TRANSISTOR SMD		C100	VE-30012576	CAPACITOR SMD	56pF 50V J CH
Q102	VE-30001457	TRANSISTOR SMD		C100	VE-30012589	CAPACITOR SMD	4.7nF 50V K
Q102	VE-30007798	TRANSISTOR SMD		C101	VE-30012560	CAPACITOR SMD	100pF 50V J
Q103	VE-30001457	TRANSISTOR SMD		C101	VE-30012589	CAPACITOR SMD	4.7nF 50V K
Q104	VE-30001457	TRANSISTOR SMD		C102	VE-30000371	E CAPACITOR	22uF 50V M
Q106	VE-30001457	TRANSISTOR SMD		C102	VE-30012560	CAPACITOR SMD	100pF 50V J
Q106	VE-30007798	TRANSISTOR SMD		C102	VE-30012571	CAPACITOR SMD	39pF 50V J
Q107	VE-30001457	TRANSISTOR SMD		C103	VE-30000294	CAPACITOR SMD	100nF 50V K
Q108	VE-30001457	TRANSISTOR SMD		C103	VE-30012560	CAPACITOR SMD	100pF 50V J
Q108	VE-30007798	TRANSISTOR SMD		C103	VE-30012571	CAPACITOR SMD	39pF 50V J
Q109	VE-30001457	TRANSISTOR SMD		C104	VE-30000345	E CAPACITOR	10uF 50V M
Q110	VE-30001457	TRANSISTOR SMD		C104	VE-30012560	CAPACITOR SMD	100pF 50V J
Q111	VE-30001457	TRANSISTOR SMD		C104	VE-30012581	CAPACITOR SMD	1nF 50V K R
Q112	VE-30001457	TRANSISTOR SMD		C105	VE-30012560	CAPACITOR SMD	100pF 50V J
Q113	VE-30001457	TRANSISTOR SMD		C105	VE-30016654	CAPACITOR SMD	100nF 16V K R
Q114	VE-30001457	TRANSISTOR SMD		C105	VE-30016654	CAPACITOR SMD	100nF 16V K R
Q115	VE-30001457	TRANSISTOR SMD		C106	VE-30000352	E CAPACITOR	100uF 16V M
Q116	VE-30001458	TRANSISTOR SMD		C106	VE-30012603	CAPACITOR SMD	100nF 25V K R
Q500	VE-30001457	TRANSISTOR SMD		C107	VE-30012581	CAPACITOR SMD	1nF 50V K R
Q501	VE-30001457	TRANSISTOR SMD		C107	VE-30016654	CAPACITOR SMD	100nF 16V K R
Q502	VE-30001457	TRANSISTOR SMD		C108	VE-30000315	CAPACITOR SMD	220nF 25V Z
Q503	VE-30001457	TRANSISTOR SMD		C108	VE-30000352	E CAPACITOR	100uF 16V M
Q504	VE-30001458	TRANSISTOR SMD		C109	VE-30012569	CAPACITOR SMD	33pF 50V J
Q505	VE-30001457	TRANSISTOR SMD		C109	VE-30012610	CAPACITOR SMD	10nF 50V J
Q506	VE-30001457	TRANSISTOR SMD		C110	VE-30000345	E CAPACITOR	10uF 50V M
Q507	VE-30001457	TRANSISTOR SMD		C110	VE-30016654	CAPACITOR SMD	100nF 16V K R
Q508	VE-30001457	TRANSISTOR SMD		C111	VE-30000315	CAPACITOR SMD	220nF 25V Z
Q509	VE-30001457	TRANSISTOR SMD		C111	VE-30000359	E CAPACITOR	1000uF 16V M
Q600	VE-30001457	TRANSISTOR SMD					
Q601	VE-30001458	TRANSISTOR SMD					
Q602	VE-30001457	TRANSISTOR SMD					

△Ref No.	Part No.	Part Name	Description Local	△Ref No.	Part No.	Part Name	Description Local
C112	VE-30012571	CAPACITOR SMD	39pF 50V J	C194	VE-30012582	CAPACITOR SMD	10nF 50V K R
C113	VE-30000371	E CAPACITOR	22uF 50V M	C195	VE-30000345	E CAPACITOR	10uF 50V M
C114	VE-30000345	E CAPACITOR	10uF 50V M	C196	VE-30012581	CAPACITOR SMD	1nF 50V K R
C115	VE-30012569	CAPACITOR SMD	33pF 50V J	C197	VE-30012581	CAPACITOR SMD	1nF 50V K R
C116	VE-30000315	CAPACITOR SMD	220nF 25V Z	C198	VE-30000345	E CAPACITOR	10uF 50V M
C116	VE-30016654	CAPACITOR SMD	100nF 16V K R	C199	VE-30012603	CAPACITOR SMD	100nF 25V K R
C117	VE-30000352	E CAPACITOR	100uF 16V M	C200	VE-30012581	CAPACITOR SMD	1nF 50V K R
C117	VE-30000400	E CAPACITOR	47uF 50V M	C201	VE-30012581	CAPACITOR SMD	1nF 50V K R
C118	VE-30012573	CAPACITOR SMD	47pF 50V J	C202	VE-30012581	CAPACITOR SMD	1nF 50V K R
C118	VE-30012610	CAPACITOR SMD	10nF 50V J	C203	VE-30012581	CAPACITOR SMD	1nF 50V K R
C119	VE-30012573	CAPACITOR SMD	47pF 50V J	C204	VE-30012581	CAPACITOR SMD	1nF 50V K R
C119	VE-30016654	CAPACITOR SMD	100nF 16V K R	C205	VE-30012581	CAPACITOR SMD	1nF 50V K R
C120	VE-30000315	CAPACITOR SMD	220nF 25V Z	C206	VE-30000345	E CAPACITOR	10uF 50V M
C120	VE-30000359	E CAPACITOR	1000uF 16V M	C207	VE-30000371	E CAPACITOR	22uF 50V M
C121	VE-30012581	CAPACITOR SMD	1nF 50V K R	C208	VE-30016126	CAPACITOR SMD	220nF 16V K R
C121	VE-30016654	CAPACITOR SMD	100nF 16V K R	C209	VE-30016126	CAPACITOR SMD	220nF 16V K R
C122	VE-30000352	E CAPACITOR	100uF 16V M	C210	VE-30000393	E CAPACITOR	3.3uF 50V M
C123	VE-30012569	CAPACITOR SMD	33pF 50V J	C211	VE-30012603	CAPACITOR SMD	100nF 25V K R
C123	VE-30016654	CAPACITOR SMD	100nF 16V K R	C212	VE-30012583	CAPACITOR SMD	1.5nF 50V K
C124	VE-30000352	E CAPACITOR	100uF 16V M	C213	VE-30016126	CAPACITOR SMD	220nF 16V K R
C124	VE-30012569	CAPACITOR SMD	33pF 50V J	C214	VE-30016126	CAPACITOR SMD	220nF 16V K R
C125	VE-30000359	E CAPACITOR	1000uF 16V M	C215	VE-30016126	CAPACITOR SMD	220nF 16V K R
C125	VE-30012603	CAPACITOR SMD	100nF 25V K R	C216	VE-30016126	CAPACITOR SMD	220nF 16V K R
C126	VE-30000359	E CAPACITOR	1000uF 16V M	C217	VE-30016126	CAPACITOR SMD	220nF 16V K R
C126	VE-30016126	CAPACITOR SMD	220nF 16V K R	C218	VE-30016126	CAPACITOR SMD	220nF 16V K R
C127	VE-30000359	E CAPACITOR	1000uF 16V M	C219	VE-30016126	CAPACITOR SMD	220nF 16V K R
C127	VE-30012582	CAPACITOR SMD	10nF 50V K R	C220	VE-30012577	CAPACITOR SMD	560pF 50V J
C128	VE-30007748	E CAPACITOR	1000uF 35V M	C221	VE-30000371	E CAPACITOR	22uF 50V M
C128	VE-30012572	CAPACITOR SMD	390pF 50V J	C222	VE-30012574	CAPACITOR SMD	470pF 50V J
C130	VE-30012610	CAPACITOR SMD	10nF 50V J	C223	VE-30000352	E CAPACITOR	100uF 16V M
C131	VE-30000345	E CAPACITOR	10uF 50V M	C224	VE-30012583	CAPACITOR SMD	1.5nF 50V K
C132	VE-30000315	CAPACITOR SMD	220nF 25V Z	C225	VE-30000345	E CAPACITOR	10uF 50V M
C133	VE-30000315	CAPACITOR SMD	220nF 25V Z	C226	VE-30012581	CAPACITOR SMD	1nF 50V K R
C134	VE-30012571	CAPACITOR SMD	39pF 50V J	C227	VE-30012576	CAPACITOR SMD	56pF 50V J CH
C135	VE-30012571	CAPACITOR SMD	39pF 50V J	C229	VE-30000345	E CAPACITOR	10uF 50V M
C136	VE-30012566	CAPACITOR SMD	22pF 50V J	C230	VE-30012576	CAPACITOR SMD	56pF 50V J CH
C137	VE-30016126	CAPACITOR SMD	220nF 16V K R	C232	VE-30012576	CAPACITOR SMD	56pF 50V J CH
C139	VE-30012603	CAPACITOR SMD	100nF 25V K R	C234	VE-30012565	CAPACITOR SMD	1.8pF 50V J CH
C140	VE-30012583	CAPACITOR SMD	1.5nF 50V K	C235	VE-30012581	CAPACITOR SMD	1nF 50V K R
C141	VE-30012582	CAPACITOR SMD	10nF 50V K R	C236	VE-30000371	E CAPACITOR	22uF 50V M
C142	VE-30000345	E CAPACITOR	10uF 50V M	C237	VE-30012581	CAPACITOR SMD	1nF 50V K R
C144	VE-30012603	CAPACITOR SMD	100nF 25V K R	C238	VE-30012565	CAPACITOR SMD	1.8pF 50V J CH
C145	VE-30000353	E CAPACITOR	100uF 25V M	C239	VE-30012581	CAPACITOR SMD	1nF 50V K R
C146	VE-30012603	CAPACITOR SMD	100nF 25V K R	C240	VE-30012581	CAPACITOR SMD	1nF 50V K R
C147	VE-30012603	CAPACITOR SMD	100nF 25V K R	C241	VE-30000371	E CAPACITOR	22uF 50V M
C148	VE-30000100	CAPACITOR MKT	330nF 63V J	C242	VE-30012581	CAPACITOR SMD	1nF 50V K R
C149	VE-30012581	CAPACITOR SMD	1nF 50V K R	C243	VE-30012581	CAPACITOR SMD	1nF 50V K R
C150	VE-30012585	CAPACITOR SMD	2.2nF 50V K R	C244	VE-30012581	CAPACITOR SMD	1nF 50V K R
C151	VE-30012585	CAPACITOR SMD	2.2nF 50V K R	C245	VE-30012581	CAPACITOR SMD	1nF 50V K R
C152	VE-30000396	E CAPACITOR	47uF 16V M	C246	VE-30012560	CAPACITOR SMD	100pF 50V J
C153	VE-30000352	E CAPACITOR	100uF 16V M	C247	VE-30000371	E CAPACITOR	22uF 50V M
C154	VE-30012576	CAPACITOR SMD	56pF 50V J CH	C248	VE-30000407	E CAPACITOR	470uF 16V M
C155	VE-30012585	CAPACITOR SMD	2.2nF 50V K R	C249	VE-30009208	C CAPACITOR	470pF 1KV K
C156	VE-30012581	CAPACITOR SMD	1nF 50V K R	C250	VE-30012571	CAPACITOR SMD	39pF 50V J
C157	VE-30012581	CAPACITOR SMD	1nF 50V K R	C251	VE-30012574	CAPACITOR SMD	470pF 50V J
C158	VE-30012603	CAPACITOR SMD	100nF 25V K R	C252	VE-30012568	CAPACITOR SMD	270pF 50V J
C160	VE-30012569	CAPACITOR SMD	33pF 50V J	C253	VE-30012583	CAPACITOR SMD	1.5nF 50V K
C161	VE-30000345	E CAPACITOR	10uF 50V M	C254	VE-30012571	CAPACITOR SMD	39pF 50V J
C162	VE-30000345	E CAPACITOR	10uF 50V M	C255	VE-30000345	E CAPACITOR	10uF 50V M
C163	VE-30012581	CAPACITOR SMD	1nF 50V K R	C256	VE-30000352	E CAPACITOR	100uF 16V M
C164	VE-30012569	CAPACITOR SMD	33pF 50V J	C257	VE-30012560	CAPACITOR SMD	100pF 50V J
C165	VE-30000400	E CAPACITOR	47uF 50V M	C258	VE-30012560	CAPACITOR SMD	100pF 50V J
C166	VE-30012576	CAPACITOR SMD	56pF 50V J CH	C259	VE-30012608	CAPACITOR SMD	27pF 50V J CH
C167	VE-30000352	E CAPACITOR	100uF 16V M	C260	VE-30012608	CAPACITOR SMD	27pF 50V J CH
C168	VE-30012571	CAPACITOR SMD	39pF 50V J	C261	VE-30012608	CAPACITOR SMD	27pF 50V J CH
C169	VE-30012585	CAPACITOR SMD	2.2nF 50V K R	C265	VE-30012607	CAPACITOR SMD	150pF 50V J
C170	VE-30012571	CAPACITOR SMD	39pF 50V J	C266	VE-30012589	CAPACITOR SMD	4.7nF 50V K
C171	VE-30012569	CAPACITOR SMD	33pF 50V J	C267	VE-30012589	CAPACITOR SMD	4.7nF 50V K
C172	VE-30012569	CAPACITOR SMD	33pF 50V J	C270	VE-30016654	CAPACITOR SMD	100nF 16V K R
C173	VE-30000074	CAPACITOR MKT	100nF 63V J	C271	VE-30012589	CAPACITOR SMD	4.7nF 50V K
C174	VE-30016126	CAPACITOR SMD	220nF 16V K R	C272	VE-30012589	CAPACITOR SMD	4.7nF 50V K
C175	VE-30012582	CAPACITOR SMD	10nF 50V K R	C273	VE-30012589	CAPACITOR SMD	4.7nF 50V K
C176	VE-30012572	CAPACITOR SMD	390pF 50V J	C274	VE-30012607	CAPACITOR SMD	150pF 50V J
C177	VE-30000100	CAPACITOR MKT	330nF 63V J	C275	VE-30012589	CAPACITOR SMD	4.7nF 50V K
C179	VE-30012610	CAPACITOR SMD	10nF 50V J	C276	VE-30012589	CAPACITOR SMD	4.7nF 50V K
C180	VE-30000407	E CAPACITOR	470uF 16V M	C277	VE-30012607	CAPACITOR SMD	150pF 50V J
C181	VE-30016654	CAPACITOR SMD	100nF 16V K R	C278	VE-30012607	CAPACITOR SMD	150pF 50V J
C183	VE-30012581	CAPACITOR SMD	1nF 50V K R	C279	VE-30012589	CAPACITOR SMD	4.7nF 50V K
C184	VE-30000352	E CAPACITOR	100uF 16V M	C280	VE-30012589	CAPACITOR SMD	4.7nF 50V K
C185	VE-30012603	CAPACITOR SMD	100nF 25V K R	C281	VE-30012589	CAPACITOR SMD	4.7nF 50V K
C186	VE-30016654	CAPACITOR SMD	100nF 16V K R	C282	VE-30012607	CAPACITOR SMD	150pF 50V J
C187	VE-30012566	CAPACITOR SMD	22pF 50V J	C283	VE-30012607	CAPACITOR SMD	150pF 50V J
C188	VE-30016126	CAPACITOR SMD	220nF 16V K R	C284	VE-30012607	CAPACITOR SMD	150pF 50V J
C189	VE-30012581	CAPACITOR SMD	1nF 50V K R	C286	VE-30012607	CAPACITOR SMD	150pF 50V J
C191	VE-30016654	CAPACITOR SMD	100nF 16V K R	C288	VE-30012607	CAPACITOR SMD	150pF 50V J
C192	VE-30012583	CAPACITOR SMD	1.5nF 50V K	C291	VE-30012607	CAPACITOR SMD	150pF 50V J
C193	VE-30016654	CAPACITOR SMD	100nF 16V K R	C292	VE-30012581	CAPACITOR SMD	1nF 50V K R

△Ref No.	Part No.	Part Name	Description Local	△Ref No.	Part No.	Part Name	Description Local
C293	VE-30012589	CAPACITOR SMD	4.7nF 50V K	C462	VE-30012570	CAPACITOR SMD	330pF 50V J
C294	VE-30012581	CAPACITOR SMD	1nF 50V K R	C463	VE-30000345	E CAPACITOR	10uF 50V M
C295	VE-30012607	CAPACITOR SMD	150pF 50V J	C464	VE-30012560	CAPACITOR SMD	100pF 50V J
C296	VE-30012589	CAPACITOR SMD	4.7nF 50V K	C465	VE-30012570	CAPACITOR SMD	330pF 50V J
C297	VE-30012607	CAPACITOR SMD	150pF 50V J	C466	VE-30012570	CAPACITOR SMD	330pF 50V J
C298	VE-30012607	CAPACITOR SMD	150pF 50V J	C467	VE-30012570	CAPACITOR SMD	330pF 50V J
C299	VE-30012607	CAPACITOR SMD	150pF 50V J	C468	VE-30012570	CAPACITOR SMD	330pF 50V J
C300	VE-30000400	E CAPACITOR	47uF 50V M	C469	VE-30012603	CAPACITOR SMD	100nF 25V K R
C301	VE-30016654	CAPACITOR SMD	100nF 16V K R	C500	VE-30012603	CAPACITOR SMD	100nF 25V K R
C302	VE-30012607	CAPACITOR SMD	150pF 50V J	C501	VE-30012603	CAPACITOR SMD	100nF 25V K R
C303	VE-30012607	CAPACITOR SMD	150pF 50V J	C502	VE-30012603	CAPACITOR SMD	100nF 25V K R
C304	VE-30012607	CAPACITOR SMD	150pF 50V J	C503	VE-30012603	CAPACITOR SMD	100nF 25V K R
C325	VE-30012571	CAPACITOR SMD	39pF 50V J	C504	VE-30012603	CAPACITOR SMD	100nF 25V K R
C326	VE-30012571	CAPACITOR SMD	39pF 50V J	C505	VE-30012603	CAPACITOR SMD	100nF 25V K R
C327	VE-30012602	CAPACITOR SMD	10nF 25V K R	C506	VE-30012603	CAPACITOR SMD	100nF 25V K R
C328	VE-30012590	CAPACITOR SMD	47nF 50V K	C507	VE-30012603	CAPACITOR SMD	100nF 25V K R
C329	VE-30012590	CAPACITOR SMD	47nF 50V K	C508	VE-30012603	CAPACITOR SMD	100nF 25V K R
C330	VE-30012590	CAPACITOR SMD	47nF 50V K	C509	VE-30012603	CAPACITOR SMD	100nF 25V K R
C331	VE-30012590	CAPACITOR SMD	47nF 50V K	C510	VE-30012603	CAPACITOR SMD	100nF 25V K R
C332	VE-30012590	CAPACITOR SMD	47nF 50V K	C511	VE-30012603	CAPACITOR SMD	100nF 25V K R
C333	VE-30012590	CAPACITOR SMD	47nF 50V K	C512	VE-30012603	CAPACITOR SMD	100nF 25V K R
C334	VE-30012590	CAPACITOR SMD	47nF 50V K	C513	VE-30012603	CAPACITOR SMD	100nF 25V K R
C335	VE-30012590	CAPACITOR SMD	47nF 50V K	C514	VE-30012603	CAPACITOR SMD	100nF 25V K R
C336	VE-30012606	CAPACITOR SMD	47nF 25V K R	C515	VE-30012603	CAPACITOR SMD	100nF 25V K R
C337	VE-30012590	CAPACITOR SMD	47nF 50V K	C516	VE-30000371	E CAPACITOR	22uF 50V M
C338	VE-30012590	CAPACITOR SMD	47nF 50V K	C517	VE-30012603	CAPACITOR SMD	100nF 25V K R
C339	VE-30000294	CAPACITOR SMD	100nF 50V K	C518	VE-30012610	CAPACITOR SMD	10nF 50V J
C340	VE-30000294	CAPACITOR SMD	100nF 50V K	C519	VE-30016654	CAPACITOR SMD	100nF 16V K R
C341	VE-30000294	CAPACITOR SMD	100nF 50V K	C520	VE-30012564	CAPACITOR SMD	18pF 50V J
C342	VE-30000294	CAPACITOR SMD	100nF 50V K	C521	VE-30016654	CAPACITOR SMD	100nF 16V K R
C343	VE-30000294	CAPACITOR SMD	100nF 50V K	C522	VE-30012564	CAPACITOR SMD	18pF 50V J
C344	VE-30000294	CAPACITOR SMD	100nF 50V K	C523	VE-30000362	E CAPACITOR	1uF 50V M
C345	VE-30000294	CAPACITOR SMD	100nF 50V K	C524	VE-30016654	CAPACITOR SMD	100nF 16V K R
C346	VE-30000294	CAPACITOR SMD	100nF 50V K	C525	VE-30000362	E CAPACITOR	1uF 50V M
C347	VE-30000294	CAPACITOR SMD	100nF 50V K	C526	VE-30000345	E CAPACITOR	10uF 50V M
C348	VE-30000294	CAPACITOR SMD	100nF 50V K	C527	VE-30016654	CAPACITOR SMD	100nF 16V K R
C349	VE-30000294	CAPACITOR SMD	100nF 50V K	C528	VE-30012603	CAPACITOR SMD	100nF 25V K R
C350	VE-30000294	CAPACITOR SMD	100nF 50V K	C529	VE-30000371	E CAPACITOR	22uF 50V M
C351	VE-30016654	CAPACITOR SMD	100nF 16V K R	C530	VE-30000371	E CAPACITOR	22uF 50V M
C352	VE-30000353	E CAPACITOR	100uF 25V M	C531	VE-30000345	E CAPACITOR	10uF 50V M
C353	VE-30016654	CAPACITOR SMD	100nF 16V K R	C532	VE-30000345	E CAPACITOR	10uF 50V M
C354	VE-30000352	E CAPACITOR	100uF 16V M	C533	VE-30012603	CAPACITOR SMD	100nF 25V K R
C355	VE-30000352	E CAPACITOR	100uF 16V M	C534	VE-30012603	CAPACITOR SMD	100nF 25V K R
C375	VE-30010571	E CAPACITOR	10uF 16V M	C535	VE-30012603	CAPACITOR SMD	100nF 25V K R
C376	VE-30012603	CAPACITOR SMD	100nF 25V K R	C536	VE-30012603	CAPACITOR SMD	100nF 25V K R
C377	VE-30012603	CAPACITOR SMD	100nF 25V K R	C537	VE-30016654	CAPACITOR SMD	100nF 16V K R
C378	VE-30012603	CAPACITOR SMD	100nF 25V K R	C539	VE-30012577	CAPACITOR SMD	560pF 50V J
C379	VE-30012603	CAPACITOR SMD	100nF 25V K R	C540	VE-30000352	E CAPACITOR	100uF 16V M
C380	VE-30000371	E CAPACITOR	22uF 50V M	C541	VE-30012603	CAPACITOR SMD	100nF 25V K R
C381	VE-30012603	CAPACITOR SMD	100nF 25V K R	C542	VE-30012603	CAPACITOR SMD	100nF 25V K R
C382	VE-30012603	CAPACITOR SMD	100nF 25V K R	C600	VE-30000359	E CAPACITOR	1000uF 16V M
C383	VE-30012590	CAPACITOR SMD	47nF 50V K	C601	VE-30000359	E CAPACITOR	1000uF 16V M
C384	VE-30012603	CAPACITOR SMD	100nF 25V K R	C602	VE-30012609	CAPACITOR SMD	68nF 50V K
C385	VE-30012603	CAPACITOR SMD	100nF 25V K R	C603	VE-30000353	E CAPACITOR	100uF 25V M
C386	VE-30012603	CAPACITOR SMD	100nF 25V K R	C604	VE-30016654	CAPACITOR SMD	100nF 16V K R
C387	VE-30012581	CAPACITOR SMD	1nF 50V K R	C606	VE-30012603	CAPACITOR SMD	100nF 25V K R
C388	VE-30012590	CAPACITOR SMD	47nF 50V K	C607	VE-30000362	E CAPACITOR	1uF 50V M
C389	VE-30012603	CAPACITOR SMD	100nF 25V K R	C608	VE-30012603	CAPACITOR SMD	100nF 25V K R
C390	VE-30012603	CAPACITOR SMD	100nF 25V K R	C609	VE-30012587	CAPACITOR SMD	3.3nF 50V K
C391	VE-30012590	CAPACITOR SMD	47nF 50V K	C610	VE-30000400	E CAPACITOR	47uF 50V M
C392	VE-30012603	CAPACITOR SMD	100nF 25V K R	C611	VE-30012603	CAPACITOR SMD	100nF 25V K R
C393	VE-30012603	CAPACITOR SMD	100nF 25V K R	C612	VE-30000359	E CAPACITOR	1000uF 16V M
C394	VE-30012603	CAPACITOR SMD	100nF 25V K R	C613	VE-30000400	E CAPACITOR	47uF 50V M
C395	VE-30012603	CAPACITOR SMD	100nF 25V K R	C614	VE-30000316	C CAPACITOR	220nF 25V Z F
C396	VE-30012603	CAPACITOR SMD	100nF 25V K R	C615	VE-30012603	CAPACITOR SMD	100nF 25V K R
C397	VE-30012603	CAPACITOR SMD	100nF 25V K R	C616	VE-30000362	E CAPACITOR	1uF 50V M
C398	VE-30012603	CAPACITOR SMD	100nF 25V K R	C617	VE-30000352	E CAPACITOR	100uF 16V M
C399	VE-30000353	E CAPACITOR	100uF 25V M	C618	VE-30000352	E CAPACITOR	100uF 16V M
C400	VE-30000353	E CAPACITOR	100uF 25V M	C650	VE-30012602	CAPACITOR SMD	10nF 25V K R
C401	VE-30012587	CAPACITOR SMD	3.3nF 50V K	C651	VE-30012571	CAPACITOR SMD	39pF 50V J
C402	VE-30012588	CAPACITOR SMD	33nF 50V K	C652	VE-30012571	CAPACITOR SMD	39pF 50V J
C403	VE-30016654	CAPACITOR SMD	100nF 16V K R	C653	VE-30012590	CAPACITOR SMD	47nF 50V K
C404	VE-30000352	E CAPACITOR	100uF 16V M	C654	VE-30012590	CAPACITOR SMD	47nF 50V K
C405	VE-30000352	E CAPACITOR	100uF 16V M	C655	VE-30012590	CAPACITOR SMD	47nF 50V K
C406	VE-30016654	CAPACITOR SMD	100nF 16V K R	C656	VE-30012590	CAPACITOR SMD	47nF 50V K
C450	VE-30000345	E CAPACITOR	10uF 50V M	C657	VE-30012590	CAPACITOR SMD	47nF 50V K
C451	VE-30012570	CAPACITOR SMD	330pF 50V J	C658	VE-30012590	CAPACITOR SMD	47nF 50V K
C452	VE-30000345	E CAPACITOR	10uF 50V M	C659	VE-30012606	CAPACITOR SMD	47nF 25V K R
C453	VE-30012570	CAPACITOR SMD	330pF 50V J	C660	VE-30012590	CAPACITOR SMD	47nF 50V K
C454	VE-30012570	CAPACITOR SMD	330pF 50V J	C661	VE-30012590	CAPACITOR SMD	47nF 50V K
C455	VE-30012560	CAPACITOR SMD	100pF 50V J	C662	VE-30012590	CAPACITOR SMD	47nF 50V K
C456	VE-30012560	CAPACITOR SMD	100pF 50V J	C663	VE-30012606	CAPACITOR SMD	47nF 25V K R
C457	VE-30012570	CAPACITOR SMD	330pF 50V J	C664	VE-30000294	CAPACITOR SMD	100nF 50V K
C458	VE-30012570	CAPACITOR SMD	330pF 50V J	C665	VE-30000294	CAPACITOR SMD	100nF 50V K
C459	VE-30012570	CAPACITOR SMD	330pF 50V J	C666	VE-30000294	CAPACITOR SMD	100nF 50V K
C460	VE-30012560	CAPACITOR SMD	100pF 50V J	C667	VE-30000294	CAPACITOR SMD	100nF 50V K
C461	VE-30012560	CAPACITOR SMD	100pF 50V J	C668	VE-30000294	CAPACITOR SMD	100nF 50V K

△Ref No.	Part No.	Part Name	Description Local	△Ref No.	Part No.	Part Name	Description Local
C669	VE-30000294	CAPACITOR SMD	100nF 50V K	R1	VE-30000460	RESISTOR CF	1/4W 100R G
C670	VE-30000294	CAPACITOR SMD	100nF 50V K	R2	VE-30000460	RESISTOR CF	1/4W 100R G
C671	VE-30000294	CAPACITOR SMD	100nF 50V K	R50	VE-30000459	RESISTOR CF	1/4W 100R J
C672	VE-30000294	CAPACITOR SMD	100nF 50V K	R100	VE-30012655	RESISTOR SMD	1/16W 180R J
C673	VE-30000294	CAPACITOR SMD	100nF 50V K	R100	VE-30014022	RESISTOR SMD	1/16W 47R J
C674	VE-30000294	CAPACITOR SMD	100nF 50V K	R100	VE-30014076	RESISTOR SMD	1/16W 4.7R J
C675	VE-30000294	CAPACITOR SMD	100nF 50V K	△R100	VE-30018085	CAPACITOR VAR	SAFE 510V K
C676	VE-30000294	CAPACITOR SMD	100nF 50V K	R101	VE-30012713	RESISTOR SMD	1/16W 75R J
C677	VE-30016654	CAPACITOR SMD	100nF 16V K R	R101	VE-30012986	RESISTOR SMD	1/16W 68R J
C678	VE-30000353	E CAPACITOR	100uF 25V M	R101	VE-30014022	RESISTOR SMD	1/16W 47R J
C679	VE-30016654	CAPACITOR SMD	100nF 16V K R	R102	VE-30012641	RESISTOR SMD	1/16W 10K J
C680	VE-30000352	E CAPACITOR	100uF 16V M	R102	VE-30012713	RESISTOR SMD	1/16W 75R J
C681	VE-30000352	E CAPACITOR	100uF 16V M	R102	VE-30012986	RESISTOR SMD	1/16W 68R J
C700	VE-30012603	CAPACITOR SMD	100nF 25V K R	R103	VE-30012641	RESISTOR SMD	1/16W 10K J
C701	VE-30012603	CAPACITOR SMD	100nF 25V K R	R103	VE-30012659	RESISTOR SMD	1/16W 2.2K J
C702	VE-30012603	CAPACITOR SMD	100nF 25V K R	R103	VE-30012713	RESISTOR SMD	1/16W 75R J
C703	VE-30012603	CAPACITOR SMD	100nF 25V K R	R104	VE-30012659	RESISTOR SMD	1/16W 2.2K J
C704	VE-30012603	CAPACITOR SMD	100nF 25V K R	R104	VE-30012669	RESISTOR SMD	1/16W 2.2K J
C705	VE-30012564	CAPACITOR SMD	18pF 50V J	R105	VE-30012510	RESISTOR SMD	1/16W 100R J
C706	VE-30012564	CAPACITOR SMD	18pF 50V J	R105	VE-30012695	RESISTOR SMD	1/16W 470R J
C707	VE-30012603	CAPACITOR SMD	100nF 25V K R	R105	VE-30012703	RESISTOR SMD	1/16W 56K J
C708	VE-30012603	CAPACITOR SMD	100nF 25V K R	R106	VE-30012510	RESISTOR SMD	1/16W 100R J
C709	VE-30012603	CAPACITOR SMD	100nF 25V K R	R106	VE-30012669	RESISTOR SMD	1/16W 22K J
C710	VE-30012603	CAPACITOR SMD	100nF 25V K R	R106	VE-30012677	RESISTOR SMD	1/16W 3.3K J
C711	VE-30012603	CAPACITOR SMD	100nF 25V K R	R107	VE-30012510	RESISTOR SMD	1/16W 100R J
C712	VE-30012603	CAPACITOR SMD	100nF 25V K R	R107	VE-30012695	RESISTOR SMD	1/16W 470R J
C713	VE-30012610	CAPACITOR SMD	10nF 50V J	R108	VE-30012510	RESISTOR SMD	1/16W 100R J
C714	VE-30000345	E CAPACITOR	10uF 50V M	R108	VE-30014022	RESISTOR SMD	1/16W 47R J
C715	VE-30012610	CAPACITOR SMD	10nF 50V J	R109	VE-30012510	RESISTOR SMD	1/16W 100R J
C726	VE-30016654	CAPACITOR SMD	100nF 16V K R	R109	VE-30014022	RESISTOR SMD	1/16W 47R J
C727	VE-30016654	CAPACITOR SMD	100nF 16V K R	R110	VE-30012510	RESISTOR SMD	1/16W 100R J
C728	VE-30000353	E CAPACITOR	100uF 25V M	R110	VE-30012641	RESISTOR SMD	1/16W 10K J
C729	VE-30000353	E CAPACITOR	100uF 25V M	R111	VE-30012641	RESISTOR SMD	1/16W 10K J
C741	VE-30000353	E CAPACITOR	100uF 25V M	R111	VE-30012698	RESISTOR SMD	1/16W 5.6K J
C742	VE-30000353	E CAPACITOR	100uF 25V M	R112	VE-30012510	RESISTOR SMD	1/16W 100R J
C743	VE-30000353	E CAPACITOR	100uF 25V M	R112	VE-30012510	RESISTOR SMD	1/16W 100R J
C744	VE-30000353	E CAPACITOR	100uF 25V M	R113	VE-30012510	RESISTOR SMD	1/16W 100R J
C745	VE-30000353	E CAPACITOR	100uF 25V M	R113	VE-30012685	RESISTOR SMD	1/16W 33K J
C751	VE-30000355	E CAPACITOR	100uF 50V M	R114	VE-30012641	RESISTOR SMD	1/16W 10K J
C752	VE-30000237	CAPACITOR SMD	33pF 50V J	R114	VE-30012705	RESISTOR SMD	1/16W 6.8K J
C753	VE-30000294	CAPACITOR SMD	100nF 50V K	R115	VE-30012651	RESISTOR SMD	1/16W 160K J
C754	VE-30000294	CAPACITOR SMD	100nF 50V K	R115	VE-30012659	RESISTOR SMD	1/16W 2.2K J
C755	VE-30000355	E CAPACITOR	100uF 50V M	R116	VE-30000721	RESISTOR SMD	1/10W 4.7K J
C756	VE-30000294	CAPACITOR SMD	100nF 50V K	R116	VE-30012657	RESISTOR SMD	1/16W 1K J
C757	VE-30000345	E CAPACITOR	10uF 50V M	R117	VE-30000721	RESISTOR SMD	1/10W 4.7K J
C758	VE-30000209	CAPACITOR SMD	18pF 50V J	R117	VE-30012641	RESISTOR SMD	1/16W 10K J
C759	VE-30000209	CAPACITOR SMD	18pF 50V J	R118	VE-30012641	RESISTOR SMD	1/16W 10K J
C760	VE-30000294	CAPACITOR SMD	100nF 50V K	R118	VE-30013001	RESISTOR SMD	1/16W 1K F
C761	VE-30000294	CAPACITOR SMD	100nF 50V K	R119	VE-30012641	RESISTOR SMD	1/16W 10K J
C762	VE-30000294	CAPACITOR SMD	100nF 50V K	R119	VE-30012692	RESISTOR SMD	1/16W 4.7K J
C763	VE-30000294	CAPACITOR SMD	100nF 50V K	R120	VE-30012641	RESISTOR SMD	1/16W 10K J
C764	VE-30000294	CAPACITOR SMD	100nF 50V K	R120	VE-30012641	RESISTOR SMD	1/16W 10K J
C765	VE-30000294	CAPACITOR SMD	100nF 50V K	R121	VE-30012641	RESISTOR SMD	1/16W 10K J
C775	VE-30000376	E CAPACITOR	220uF 25V M	R122	VE-30014420	RESISTOR SMD	1/16W 10K F
C776	VE-30020694	CAPACITOR SMD	1uF 16V Z Y5V	R123	VE-30012510	RESISTOR SMD	1/16W 100R J
C777	VE-30000294	CAPACITOR SMD	100nF 50V K	R124	VE-30012510	RESISTOR SMD	1/16W 100R J
C778	VE-30000294	CAPACITOR SMD	100nF 50V K	R124	VE-30012641	RESISTOR SMD	1/16W 10K J
C779	VE-30012567	CAPACITOR SMD	220pF 50V J	R125	VE-30012641	RESISTOR SMD	1/16W 10K J
C780	VE-30012610	CAPACITOR SMD	10nF 50V J	R125	VE-30014022	RESISTOR SMD	1/16W 47R J
C781	VE-30012610	CAPACITOR SMD	10nF 50V J	R126	VE-30012510	RESISTOR SMD	1/16W 100R J
C782	VE-30000294	CAPACITOR SMD	100nF 50V K	R127	VE-30012510	RESISTOR SMD	1/16W 100R J
C783	VE-30000294	CAPACITOR SMD	100nF 50V K	R127	VE-30012713	RESISTOR SMD	1/16W 75R J
C784	VE-30000376	E CAPACITOR	220uF 25V M	R128	VE-30012669	RESISTOR SMD	1/16W 22K J
C785	VE-30012581	CAPACITOR SMD	1nF 50V K R	R129	VE-30012705	RESISTOR SMD	1/16W 6.8K J
C786	VE-30012581	CAPACITOR SMD	1nF 50V K R	R130	VE-30012657	RESISTOR SMD	1/16W 1K J
C787	VE-30020694	CAPACITOR SMD	1uF 16V Z Y5V	R131	VE-30012510	RESISTOR SMD	1/16W 100R J
C788	VE-30020694	CAPACITOR SMD	1uF 16V Z Y5V	R131	VE-30012641	RESISTOR SMD	1/16W 10K J
C789	VE-30020694	CAPACITOR SMD	1uF 16V Z Y5V	R132	VE-30012641	RESISTOR SMD	1/16W 10K J
C790	VE-30020694	CAPACITOR SMD	1uF 16V Z Y5V	R132	VE-30012713	RESISTOR SMD	1/16W 75R J
C791	VE-30020694	CAPACITOR SMD	1uF 16V Z Y5V	R133	VE-30012510	RESISTOR SMD	1/16W 100R J
C792	VE-30020694	CAPACITOR SMD	1uF 16V Z Y5V	R133	VE-30012669	RESISTOR SMD	1/16W 22K J
C793	VE-30012610	CAPACITOR SMD	10nF 50V J	R134	VE-30012510	RESISTOR SMD	1/16W 100R J
C794	VE-30012610	CAPACITOR SMD	10nF 50V J	R135	VE-30012510	RESISTOR SMD	1/16W 100R J
C795	VE-30012581	CAPACITOR SMD	1nF 50V K R	R136	VE-30012713	RESISTOR SMD	1/16W 75R J
C796	VE-30012581	CAPACITOR SMD	1nF 50V K R	R137	VE-30012657	RESISTOR SMD	1/16W 1K J
C800	VE-30000294	CAPACITOR SMD	100nF 50V K	R138	VE-30012713	RESISTOR SMD	1/16W 75R J
C801	VE-30000294	CAPACITOR SMD	100nF 50V K	R139	VE-30012713	RESISTOR SMD	1/16W 75R J
C802	VE-30000294	CAPACITOR SMD	100nF 50V K	R140	VE-30012657	RESISTOR SMD	1/16W 1K J
C803	VE-30000376	E CAPACITOR	220uF 25V M	R142	VE-30012713	RESISTOR SMD	1/16W 75R J
C804	VE-30000353	E CAPACITOR	100uF 25V M	R143	VE-30012657	RESISTOR SMD	1/16W 1K J
C805	VE-30000109	CAPACITOR MKT	470nF 63V J	R144	VE-30012644	RESISTOR SMD	1/16W 12K J
C806	VE-30000109	CAPACITOR MKT	470nF 63V J	R145	VE-30012668	RESISTOR SMD	1/16W 220R J
C807	VE-30000109	CAPACITOR MKT	470nF 63V J	R146	VE-30012657	RESISTOR SMD	1/16W 1K J
C808	VE-30000109	CAPACITOR MKT	470nF 63V J	R147	VE-30012657	RESISTOR SMD	1/16W 1K J
C809	VE-30033474	E CAPACITOR	2200uF 16V M	R148	VE-30012644	RESISTOR SMD	1/16W 12K J
C810	VE-30033474	E CAPACITOR	2200uF 16V M	R149	VE-30012703	RESISTOR SMD	1/16W 56K J
C990	VE-30000237	CAPACITOR SMD	33pF 50V J	R150	VE-30012649	RESISTOR SMD	1/16W 150R J

△Ref No.	Part No.	Part Name	Description Local	△Ref No.	Part No.	Part Name	Description Local
R151	VE-30012641	RESISTOR SMD	1/16W 10K J	R291	VE-30012713	RESISTOR SMD	1/16W 75R J
R152	VE-30012713	RESISTOR SMD	1/16W 75R J	R292	VE-30012713	RESISTOR SMD	1/16W 75R J
R153	VE-30012657	RESISTOR SMD	1/16W 1K J	R295	VE-30012713	RESISTOR SMD	1/16W 75R J
R154	VE-30012713	RESISTOR SMD	1/16W 75R J	R296	VE-30012713	RESISTOR SMD	1/16W 75R J
R155	VE-30014022	RESISTOR SMD	1/16W 47R J	R297	VE-30012707	RESISTOR SMD	1/16W 680R J
R156	VE-30012641	RESISTOR SMD	1/16W 10K J	R298	VE-30012713	RESISTOR SMD	1/16W 75R J
R157	VE-30012692	RESISTOR SMD	1/16W 4.7K J	R299	VE-30013001	RESISTOR SMD	1/16W 1K F
R158	VE-30012651	RESISTOR SMD	1/16W 160K J	R300	VE-30012713	RESISTOR SMD	1/16W 75R J
R159	VE-30012669	RESISTOR SMD	1/16W 22K J	R301	VE-30012510	RESISTOR SMD	1/16W 100R J
R160	VE-30012713	RESISTOR SMD	1/16W 75R J	R302	VE-30012713	RESISTOR SMD	1/16W 75R J
R161	VE-30012510	RESISTOR SMD	1/16W 100R J	R303	VE-30012713	RESISTOR SMD	1/16W 75R J
R162	VE-30012510	RESISTOR SMD	1/16W 100R J	R304	VE-30012692	RESISTOR SMD	1/16W 4.7K J
R163	VE-30012510	RESISTOR SMD	1/16W 100R J	R326	VE-30014022	RESISTOR SMD	1/16W 47R J
R164	VE-30012510	RESISTOR SMD	1/16W 100R J	R327	VE-30012510	RESISTOR SMD	1/16W 100R J
R165	VE-30012651	RESISTOR SMD	1/16W 160K J	R328	VE-30012510	RESISTOR SMD	1/16W 100R J
R166	VE-30012698	RESISTOR SMD	1/16W 5.6K J	R329	VE-30017653	RESISTOR SARRAY	1/16W 47RX4 J
R167	VE-30012641	RESISTOR SMD	1/16W 10K J	R330	VE-30012987	RESISTOR SMD	1/16W 56R J
R168	VE-30012510	RESISTOR SMD	1/16W 100R J	R331	VE-30017653	RESISTOR SARRAY	1/16W 47RX4 J
R169	VE-30012692	RESISTOR SMD	1/16W 4.7K J	R332	VE-30014078	RESISTOR SMD	1/16W 22R J
R170	VE-30012679	RESISTOR SMD	1/16W 3.9K J	R333	VE-30012987	RESISTOR SMD	1/16W 56R J
R171	VE-30012679	RESISTOR SMD	1/16W 3.9K J	R334	VE-30017653	RESISTOR SARRAY	1/16W 47RX4 J
R172	VE-30013001	RESISTOR SMD	1/16W 1K F	R335	VE-30014078	RESISTOR SMD	1/16W 22R J
R173	VE-30012650	RESISTOR SMD	1/16W 15K J	R336	VE-30012987	RESISTOR SMD	1/16W 56R J
R174	VE-30012705	RESISTOR SMD	1/16W 6.8K J	R337	VE-30017653	RESISTOR SARRAY	1/16W 47RX4 J
R175	VE-30012679	RESISTOR SMD	1/16W 3.9K J	R338	VE-30014078	RESISTOR SMD	1/16W 22R J
R176	VE-30012669	RESISTOR SMD	1/16W 22K J	R339	VE-30014078	RESISTOR SMD	1/16W 22R J
R177	VE-30012705	RESISTOR SMD	1/16W 6.8K J	R340	VE-30017653	RESISTOR SARRAY	1/16W 47RX4 J
R178	VE-30012659	RESISTOR SMD	1/16W 2.2K J	R341	VE-30014078	RESISTOR SMD	1/16W 22R J
R179	VE-30012648	RESISTOR SMD	1/16W 150K J	R342	VE-30014078	RESISTOR SMD	1/16W 22R J
R180	VE-30012650	RESISTOR SMD	1/16W 15K J	R343	VE-30014078	RESISTOR SMD	1/16W 22R J
R181	VE-30012648	RESISTOR SMD	1/16W 150K J	R344	VE-30012987	RESISTOR SMD	1/16W 56R J
R182	VE-30012657	RESISTOR SMD	1/16W 1K J	R345	VE-30012987	RESISTOR SMD	1/16W 56R J
R184	VE-30012510	RESISTOR SMD	1/16W 100R J	R346	VE-30012987	RESISTOR SMD	1/16W 56R J
R185	VE-30012669	RESISTOR SMD	1/16W 22K J	R347	VE-30012987	RESISTOR SMD	1/16W 56R J
R186	VE-30012644	RESISTOR SMD	1/16W 12K J	R375	VE-30018372	RESISTOR SARRAY	1/16W 22R J
R187	VE-30012644	RESISTOR SMD	1/16W 12K J	R376	VE-30018372	RESISTOR SARRAY	1/16W 22R J
R188	VE-30012703	RESISTOR SMD	1/16W 56K J	R377	VE-30017653	RESISTOR SARRAY	1/16W 47RX4 J
R189	VE-30012649	RESISTOR SMD	1/16W 150R J	R378	VE-30018372	RESISTOR SARRAY	1/16W 22R J
R190	VE-30012668	RESISTOR SMD	1/16W 220R J	R379	VE-30018372	RESISTOR SARRAY	1/16W 22R J
R191	VE-30012713	RESISTOR SMD	1/16W 75R J	R380	VE-30018372	RESISTOR SARRAY	1/16W 22R J
R192	VE-30012657	RESISTOR SMD	1/16W 1K J	R381	VE-30018372	RESISTOR SARRAY	1/16W 22R J
R193	VE-30012657	RESISTOR SMD	1/16W 1K J	R382	VE-30012677	RESISTOR SMD	1/16W 3.3K J
R194	VE-30012657	RESISTOR SMD	1/16W 1K J	R457	VE-30014022	RESISTOR SMD	1/16W 47R J
R195	VE-30012657	RESISTOR SMD	1/16W 1K J	R459	VE-30012688	RESISTOR SMD	1/16W 390R J
R196	VE-30012657	RESISTOR SMD	1/16W 1K J	R465	VE-30012692	RESISTOR SMD	1/16W 4.7K J
R197	VE-30012657	RESISTOR SMD	1/16W 1K J	R466	VE-30012641	RESISTOR SMD	1/16W 10K J
R198	VE-30012657	RESISTOR SMD	1/16W 1K J	R467	VE-30012692	RESISTOR SMD	1/16W 4.7K J
R199	VE-30012657	RESISTOR SMD	1/16W 1K J	R468	VE-30012641	RESISTOR SMD	1/16W 10K J
R200	VE-30013001	RESISTOR SMD	1/16W 1K F	R469	VE-30012692	RESISTOR SMD	1/16W 4.7K J
R201	VE-30012510	RESISTOR SMD	1/16W 100R J	R470	VE-30012692	RESISTOR SMD	1/16W 4.7K J
R202	VE-30013001	RESISTOR SMD	1/16W 1K F	R471	VE-30012692	RESISTOR SMD	1/16W 4.7K J
R203	VE-30013001	RESISTOR SMD	1/16W 1K F	R472	VE-30012692	RESISTOR SMD	1/16W 4.7K J
R204	VE-30012510	RESISTOR SMD	1/16W 100R J	R500	VE-30012692	RESISTOR SMD	1/16W 4.7K J
R205	VE-30012510	RESISTOR SMD	1/16W 100R J	R501	VE-30012509	RESISTOR SMD	1/16W 100K J
R206	VE-30012510	RESISTOR SMD	1/16W 100R J	R502	VE-30012641	RESISTOR SMD	1/16W 10K J
R207	VE-30013001	RESISTOR SMD	1/16W 1K F	R503	VE-30012641	RESISTOR SMD	1/16W 10K J
R208	VE-30012510	RESISTOR SMD	1/16W 100R J	R504	VE-30014420	RESISTOR SMD	1/16W 10K F
R209	VE-30012510	RESISTOR SMD	1/16W 100R J	R505	VE-30014420	RESISTOR SMD	1/16W 10K F
R210	VE-30012657	RESISTOR SMD	1/16W 1K J	R506	VE-30012641	RESISTOR SMD	1/16W 10K J
R211	VE-30012510	RESISTOR SMD	1/16W 100R J	R507	VE-30012668	RESISTOR SMD	1/16W 220R J
R212	VE-30012657	RESISTOR SMD	1/16W 1K J	R508	VE-30014420	RESISTOR SMD	1/16W 10K F
R213	VE-30012657	RESISTOR SMD	1/16W 1K J	R509	VE-30014420	RESISTOR SMD	1/16W 10K F
R214	VE-30012510	RESISTOR SMD	1/16W 100R J	R510	VE-30030692	FERRITE NET	120R/100MHz 150mA
R215	VE-30012510	RESISTOR SMD	1/16W 100R J	R511	VE-30030692	FERRITE NET	120R/100MHz 150mA
R216	VE-30012695	RESISTOR SMD	1/16W 470R J	R512	VE-30012658	RESISTOR SMD	1/16W 1M J
R217	VE-30012695	RESISTOR SMD	1/16W 470R J	R513	VE-30030692	FERRITE NET	120R/100MHz 150mA
R218	VE-30012510	RESISTOR SMD	1/16W 100R J	R514	VE-30030692	FERRITE NET	120R/100MHz 150mA
R219	VE-30012510	RESISTOR SMD	1/16W 100R J	R515	VE-30012692	RESISTOR SMD	1/16W 4.7K J
R265	VE-30012713	RESISTOR SMD	1/16W 75R J	R516	VE-30012692	RESISTOR SMD	1/16W 4.7K J
R266	VE-30014078	RESISTOR SMD	1/16W 22R J	R517	VE-30030692	FERRITE NET	120R/100MHz 150mA
R267	VE-30012713	RESISTOR SMD	1/16W 75R J	R518	VE-30014420	RESISTOR SMD	1/16W 10K F
R268	VE-30012713	RESISTOR SMD	1/16W 75R J	R519	VE-30030692	FERRITE NET	120R/100MHz 150mA
R274	VE-30014078	RESISTOR SMD	1/16W 22R J	R520	VE-30012692	RESISTOR SMD	1/16W 4.7K J
R275	VE-30014078	RESISTOR SMD	1/16W 22R J	R521	VE-30014128	RESISTOR SMD	1/16W 33R J
R276	VE-30014078	RESISTOR SMD	1/16W 22R J	R522	VE-30012692	RESISTOR SMD	1/16W 4.7K J
R277	VE-30012675	RESISTOR SMD	1/16W 2K J	R523	VE-30012641	RESISTOR SMD	1/16W 10K J
R278	VE-30012675	RESISTOR SMD	1/16W 2K J	R524	VE-30012692	RESISTOR SMD	1/16W 4.7K J
R279	VE-30012707	RESISTOR SMD	1/16W 680R J	R525	VE-30017653	RESISTOR SARRAY	1/16W 47RX4 J
R280	VE-30012707	RESISTOR SMD	1/16W 680R J	R526	VE-30012668	RESISTOR SMD	1/16W 220R J
R281	VE-30012510	RESISTOR SMD	1/16W 100R J	R527	VE-30012668	RESISTOR SMD	1/16W 220R J
R282	VE-30012510	RESISTOR SMD	1/16W 100R J	R528	VE-30012641	RESISTOR SMD	1/16W 10K J
R283	VE-30012641	RESISTOR SMD	1/16W 10K J	R529	VE-30012692	RESISTOR SMD	1/16W 4.7K J
R284	VE-30012641	RESISTOR SMD	1/16W 10K J	R530	VE-30012692	RESISTOR SMD	1/16W 4.7K J
R285	VE-30012510	RESISTOR SMD	1/16W 100R J	R531	VE-30012692	RESISTOR SMD	1/16W 4.7K J
R286	VE-30012713	RESISTOR SMD	1/16W 75R J	R532	VE-30012692	RESISTOR SMD	1/16W 4.7K J
R289	VE-30012713	RESISTOR SMD	1/16W 75R J	R533	VE-30012692	RESISTOR SMD	1/16W 4.7K J
R290	VE-30012707	RESISTOR SMD	1/16W 680R J	R534	VE-30013001	RESISTOR SMD	1/16W 1K F

△Ref No.	Part No.	Part Name	Description Local	△Ref No.	Part No.	Part Name	Description Local
R535	VE-30012692	RESISTOR SMD	1/16W 4.7K J	R753	VE-30012696	RESISTOR SMD	1/16W 47K J
R536	VE-30012692	RESISTOR SMD	1/16W 4.7K J	R754	VE-30012696	RESISTOR SMD	1/16W 47K J
R537	VE-30012692	RESISTOR SMD	1/16W 4.7K J	R755	VE-30012510	RESISTOR SMD	1/16W 100R J
R538	VE-30012692	RESISTOR SMD	1/16W 4.7K J	R756	VE-30012657	RESISTOR SMD	1/16W 1K J
R539	VE-30012692	RESISTOR SMD	1/16W 4.7K J	R757	VE-30014420	RESISTOR SMD	1/16W 10K F
R543	VE-30014420	RESISTOR SMD	1/16W 10K F	R758	VE-30014420	RESISTOR SMD	1/16W 10K F
R544	VE-30014420	RESISTOR SMD	1/16W 10K F	R759	VE-30014022	RESISTOR SMD	1/16W 47R J
R545	VE-30012677	RESISTOR SMD	1/16W 3.3K J	R760	VE-30014128	RESISTOR SMD	1/16W 33R J
R546	VE-30012677	RESISTOR SMD	1/16W 3.3K J	R761	VE-30014128	RESISTOR SMD	1/16W 33R J
R547	VE-30012677	RESISTOR SMD	1/16W 3.3K J	R762	VE-30014128	RESISTOR SMD	1/16W 33R J
R548	VE-30012692	RESISTOR SMD	1/16W 4.7K J	R763	VE-30012671	RESISTOR SMD	1/16W 24K J
R549	VE-30012692	RESISTOR SMD	1/16W 4.7K J	R908	VE-30014420	RESISTOR SMD	1/16W 10K F
R550	VE-30012692	RESISTOR SMD	1/16W 4.7K J	R909	VE-30014420	RESISTOR SMD	1/16W 10K F
R551	VE-30012692	RESISTOR SMD	1/16W 4.7K J				
R552	VE-30012641	RESISTOR SMD	1/16W 10K J	L100	VE-30001996	FIXED COIL	22uH Q40 K
R553	VE-30012641	RESISTOR SMD	1/16W 10K J	L100	VE-30002002	FIXED COIL	47uH Q60 K
R554	VE-30012510	RESISTOR SMD	1/16W 100R J	L101	VE-30001971	FERRITE SMD	600R/100MHz 200mA
R555	VE-30012510	RESISTOR SMD	1/16W 100R J	L101	VE-30001996	FIXED COIL	22uH Q40 K
R556	VE-30012677	RESISTOR SMD	1/16W 3.3K J	L101	VE-30001996	FIXED COIL	22uH Q40 K
R557	VE-30012677	RESISTOR SMD	1/16W 3.3K J	L102	VE-30001971	FERRITE SMD	600R/100MHz 200mA
R558	VE-30012677	RESISTOR SMD	1/16W 3.3K J	L102	VE-30001979	FIXED COIL	1uH Q45 M-A
R600	VE-30012683	RESISTOR SMD	1/16W 330K J	L102	VE-30002170	FERRITE CORE	1A RAD (FTZ)
R601	VE-30012683	RESISTOR SMD	1/16W 330K J	L103	VE-30001979	FIXED COIL	1uH Q45 M-A
R602	VE-30012663	RESISTOR SMD	1/16W 200K J	L103	VE-30001979	FIXED COIL	1uH Q45 M-A
R603	VE-30012700	RESISTOR SMD	1/16W 51K J	L103	VE-30011450	FIXED COIL	22uH 5.4A
R604	VE-30012641	RESISTOR SMD	1/16W 10K J	L104	VE-30018093	FIXED COIL SMD	3.3uH J Q30 185mA
R605	VE-30012641	RESISTOR SMD	1/16W 10K J	L105	VE-30002170	FERRITE CORE	1A RAD (FTZ)
R606	VE-30012641	RESISTOR SMD	1/16W 10K J	L105	VE-30007771	FIXED COIL	100UH
R607	VE-30012665	RESISTOR SMD	1/16W 20K J	L106	VE-30001996	FIXED COIL	22uH Q40 K
R608	VE-30012641	RESISTOR SMD	1/16W 10K J	L106	VE-30011450	FIXED COIL	22uH 5.4A
R609	VE-30013001	RESISTOR SMD	1/16W 1K F	L107	VE-30001971	FERRITE SMD	600R/100MHz 200mA
R610	VE-30012641	RESISTOR SMD	1/16W 10K J	L108	VE-30001971	FERRITE SMD	600R/100MHz 200mA
R611	VE-30012692	RESISTOR SMD	1/16W 4.7K J	L109	VE-30001996	FIXED COIL	22uH Q40 K
R612	VE-30012692	RESISTOR SMD	1/16W 4.7K J	L110	VE-30001971	FERRITE SMD	600R/100MHz 200mA
R613	VE-30000526	RESISTOR CF	1/4W 1.5K J	L111	VE-30001979	FIXED COIL	1uH Q45 M-A
R614	VE-30000622	RESISTOR CF	1/4W 270R J	L112	VE-30018093	FIXED COIL SMD	3.3uH J Q30 185mA
R615	VE-30000633	RESISTOR CF	1/4W 27K J	L113	VE-30006712	FERRITE BEAD	3.5X4.7X0.8
R616	VE-30000504	RESISTOR CF	1/4W 120K J	L114	VE-30001971	FERRITE SMD	600R/100MHz 200mA
R617	VE-30012659	RESISTOR SMD	1/16W 2.2K J	L115	VE-30001971	FERRITE SMD	600R/100MHz 200mA
R620	VE-30012509	RESISTOR SMD	1/16W 100K J	L116	VE-30001971	FERRITE SMD	600R/100MHz 200mA
R651	VE-30012510	RESISTOR SMD	1/16W 100R J	L117	VE-30001971	FERRITE SMD	600R/100MHz 200mA
R652	VE-30012510	RESISTOR SMD	1/16W 100R J	L118	VE-30001971	FERRITE SMD	600R/100MHz 200mA
R653	VE-30017653	RESISTOR SARRAY	1/16W 47RX4 J	L119	VE-30001971	FERRITE SMD	600R/100MHz 200mA
R655	VE-30017653	RESISTOR SARRAY	1/16W 47RX4 J	L120	VE-30001971	FERRITE SMD	600R/100MHz 200mA
R656	VE-30014078	RESISTOR SMD	1/16W 22R J	L121	VE-30001971	FERRITE SMD	600R/100MHz 200mA
R658	VE-30017653	RESISTOR SARRAY	1/16W 47RX4 J	L122	VE-30001994	FIXED COIL	22uH J AXIAL
R659	VE-30014078	RESISTOR SMD	1/16W 22R J	L123	VE-30001996	FIXED COIL	22uH Q40 K
R661	VE-30017653	RESISTOR SARRAY	1/16W 47RX4 J	L124	VE-30001971	FERRITE SMD	600R/100MHz 200mA
R662	VE-30014078	RESISTOR SMD	1/16W 22R J	L125	VE-30001971	FERRITE SMD	600R/100MHz 200mA
R663	VE-30017653	RESISTOR SARRAY	1/16W 47RX4 J	L126	VE-30001994	FIXED COIL	22uH J AXIAL
R664	VE-30014078	RESISTOR SMD	1/16W 22R J	L127	VE-30001996	FIXED COIL	22uH Q40 K
R665	VE-30014078	RESISTOR SMD	1/16W 22R J	L265	VE-30001971	FERRITE SMD	600R/100MHz 200mA
R666	VE-30012987	RESISTOR SMD	1/16W 56R J	L266	VE-30001971	FERRITE SMD	600R/100MHz 200mA
R667	VE-30012987	RESISTOR SMD	1/16W 56R J	L267	VE-30001971	FERRITE SMD	600R/100MHz 200mA
R700	VE-30017653	RESISTOR SARRAY	1/16W 47RX4 J	L268	VE-30001971	FERRITE SMD	600R/100MHz 200mA
R701	VE-30017653	RESISTOR SARRAY	1/16W 47RX4 J	L269	VE-30001971	FERRITE SMD	600R/100MHz 200mA
R702	VE-30017653	RESISTOR SARRAY	1/16W 47RX4 J	L270	VE-30001968	FERRITE SMD	200R/100MHz 200mA
R703	VE-30017653	RESISTOR SARRAY	1/16W 47RX4 J	L271	VE-30001971	FERRITE SMD	600R/100MHz 200mA
R704	VE-30017653	RESISTOR SARRAY	1/16W 47RX4 J	L272	VE-30001968	FERRITE SMD	200R/100MHz 200mA
R705	VE-30017653	RESISTOR SARRAY	1/16W 47RX4 J	L273	VE-30001971	FERRITE SMD	600R/100MHz 200mA
R706	VE-30014022	RESISTOR SMD	1/16W 47R J	L274	VE-30001968	FERRITE SMD	200R/100MHz 200mA
R707	VE-30014022	RESISTOR SMD	1/16W 47R J	L275	VE-30001971	FERRITE SMD	600R/100MHz 200mA
R708	VE-30014022	RESISTOR SMD	1/16W 47R J	L276	VE-30001971	FERRITE SMD	600R/100MHz 200mA
R709	VE-30012692	RESISTOR SMD	1/16W 4.7K J	L277	VE-30001971	FERRITE SMD	600R/100MHz 200mA
R710	VE-30014420	RESISTOR SMD	1/16W 10K F	L280	VE-30001971	FERRITE SMD	600R/100MHz 200mA
R711	VE-30014420	RESISTOR SMD	1/16W 10K F	L281	VE-30001971	FERRITE SMD	600R/100MHz 200mA
R712	VE-30014420	RESISTOR SMD	1/16W 10K F	L282	VE-30001971	FERRITE SMD	600R/100MHz 200mA
R713	VE-30014420	RESISTOR SMD	1/16W 10K F	L283	VE-30001971	FERRITE SMD	600R/100MHz 200mA
R714	VE-30014420	RESISTOR SMD	1/16W 10K F	L284	VE-30001971	FERRITE SMD	600R/100MHz 200mA
R715	VE-30012660	RESISTOR SMD	1/16W 2.2M J	L325	VE-30017542	FIXED COIL SMD	10uH J Q25 155mA
R716	VE-30012673	RESISTOR SMD	1/16W 270R J	L326	VE-30002170	FERRITE CORE	1A RAD (FTZ)
R717	VE-30017653	RESISTOR SARRAY	1/16W 47RX4 J	L375	VE-30001992	FIXED COIL	10uH Q65 K-A
R718	VE-30012684	RESISTOR SMD	1/16W 330R J	L450	VE-30001971	FERRITE SMD	600R/100MHz 200mA
R742	VE-30012642	RESISTOR SMD	1/16W 120K J	L500	VE-30006712	FERRITE BEAD	3.5X4.7X0.8
R743	VE-30012642	RESISTOR SMD	1/16W 120K J	L501	VE-30006712	FERRITE BEAD	3.5X4.7X0.8
R744	VE-30012696	RESISTOR SMD	1/16W 47K J	L600	VE-30006712	FERRITE BEAD	3.5X4.7X0.8
R745	VE-30012708	RESISTOR SMD	1/16W 68K J	L601	VE-30006712	FERRITE BEAD	3.5X4.7X0.8
R746	VE-30012685	RESISTOR SMD	1/16W 33K J	L602	VE-30006712	FERRITE BEAD	3.5X4.7X0.8
R747	VE-30012641	RESISTOR SMD	1/16W 10K J	L603	VE-30006712	FERRITE BEAD	3.5X4.7X0.8
R748	VE-30012641	RESISTOR SMD	1/16W 10K J	L604	VE-30006712	FERRITE BEAD	3.5X4.7X0.8
R749	VE-30012509	RESISTOR SMD	1/16W 100K J	L605	VE-30006712	FERRITE BEAD	3.5X4.7X0.8
R750	VE-30012510	RESISTOR SMD	1/16W 100R J	L606	VE-30001971	FERRITE SMD	600R/100MHz 200mA
R750	VE-30012644	RESISTOR SMD	1/16W 12K J	L607	VE-30006712	FERRITE BEAD	3.5X4.7X0.8
R751	VE-30012510	RESISTOR SMD	1/16W 100R J	L608	VE-30006712	FERRITE BEAD	3.5X4.7X0.8
R751	VE-30012641	RESISTOR SMD	1/16W 10K J	L609	VE-30011450	FIXED COIL	22uH 5.4A
R752	VE-30012696	RESISTOR SMD	1/16W 47K J	L610	VE-30006712	FERRITE BEAD	3.5X4.7X0.8
R753	VE-30012644	RESISTOR SMD	1/16W 12K J	L650	VE-30017542	FIXED COIL SMD	10uH J Q25 155mA

△Ref No.	Part No.	Part Name	Description Local
L651	VE-30002170	FERRITE CORE	1A RAD (FTZ)
L700	VE-30002170	FERRITE CORE	1A RAD (FTZ)
L701	VE-30001971	FERRITE SMD	600R/100MHz 200mA
L702	VE-30001971	FERRITE SMD	600R/100MHz 200mA
L703	VE-30001971	FERRITE SMD	600R/100MHz 200mA
L704	VE-30001971	FERRITE SMD	600R/100MHz 200mA
L718	VE-30024779	FERRITE SMD	50R/100MHz 3A
L719	VE-30024779	FERRITE SMD	50R/100MHz 3A
L721	VE-30024779	FERRITE SMD	50R/100MHz 3A
L722	VE-30024779	FERRITE SMD	50R/100MHz 3A
L723	VE-30001999	FIXED COIL	40uH 4A RAD 8*10
L724	VE-30001999	FIXED COIL	40uH 4A RAD 8*10
L725	VE-30001999	FIXED COIL	40uH 4A RAD 8*10
L726	VE-30001999	FIXED COIL	40uH 4A RAD 8*10
L727	VE-30017624	DIODE	SCHOTTKY SB560 5A/60V DO-201AD
L729	VE-30011450	FIXED COIL	22uH 5.4A
L750	VE-30001996	FIXED COIL	22uH Q40 K
△F100	VE-20000849	FUSE	3.15A
JK100	VE-30001902	HEADPHONE JACK	STEREO WO/SW
JK101	VE-30001893	RCA JACK	1P YELLOW 28 FAV
JK102	VE-30001891	RCA JACK	1P WHITE 28 FAV
JK103	VE-30001892	RCA JACK	1P RED 28 FAV
JK104	VE-30001895	JACK	4P DIN TYPE FOR SVHS
JK265	VE-30001902	HEADPHONE JACK	STEREO WO/SW
JK266	VE-30001891	RCA JACK	1P WHITE 28 FAV
JK267	VE-30001892	RCA JACK	1P RED 28 FAV
SW1	VE-30002181	TACT SWITCH	
SW2	VE-30002181	TACT SWITCH	
SW3	VE-30002181	TACT SWITCH	
SW4	VE-30002181	TACT SWITCH	
SW7	VE-30002181	TACT SWITCH	
SW8	VE-30002181	TACT SWITCH	
SW9	VE-30002181	TACT SWITCH	
△TU100	VE-30020655	TUNER WSP (PLL)	38.9 TMK3-HORIZONTAL-PIP
△TU101	VE-30020654	TUNER WSP (PLL)	38.9 MK3 - HORIZONTAL
X100	VE-30002851	CLYSTAL	4.000 30p HC49U
X101	VE-30002851	CLYSTAL	4.000 30p HC49U
X102	VE-30001756	CLYSTAL	18.432 12p HC49U
X325	VE-30001741	CLYSTAL	24.576 20p HC49U
X500	VE-30017946	CLYSTAL	14.318 MHZ
X650	VE-30001741	CLYSTAL	24.576 20p HC49U
X700	VE-30001736	CLYSTAL	10.000 30p HC49U
X750	VE-30001737	CLYSTAL	12.000 20p HC49U
Z100	VE-30001692	SAW FILTER	OFWK3953M
Z101	VE-30012545	SAW FILTER	K9656M
Z102	VE-30001692	SAW FILTER	OFWK3953M
Z103	VE-30012545	SAW FILTER	K9656M

PRINTED WIRING BOARD PARTS LIST [LT-30E45SU/N]

△Ref No.	Part No.	Part Name	Description Local	△Ref No.	Part No.	Part Name	Description Local
				Q751	VE-30001458	TRANSISTOR SMD	
IC1	VE-30021628	IC		D50	VE-30001279	LED	RED/GREEN
IC2	VE-30021083	IC		D51	VE-30001279	LED	RED/GREEN
IC3	VE-30001518	IC		D100	VE-30001285	DIODE SMD	
IC4	VE-30012411	DIODE SMD		D101	VE-30011601	LED	GREEN
IC5	VE-30001285	DIODE SMD		D102	VE-30010152	LED	RED
IC6	VE-30018263	IC		D103	VE-30001313	DIODE	
IC7	VE-30021083	IC		D103	VE-30012411	DIODE SMD	
IC8	VE-30007761	DIODE SMD		D104	VE-30001313	DIODE	
IC9	VE-30001285	DIODE SMD		D265	VE-30001285	DIODE SMD	
IC10	VE-30001285	DIODE SMD		D266	VE-30001285	DIODE SMD	
IC12	VE-30013686	IC		D267	VE-30001285	DIODE SMD	
IC17	VE-30021626	IC		D268	VE-30001285	DIODE SMD	
IC18	VE-30016822	IC		D269	VE-30001285	DIODE SMD	
IC19	VE-30020632	IC		D270	VE-30001285	DIODE SMD	
IC21	VE-30028202	IC		D271	VE-30001285	DIODE SMD	
IC22	VE-30017847	IC		D272	VE-30001285	DIODE SMD	
IC23	VE-30014162	IC		D273	VE-30001285	DIODE SMD	
IC24	VE-20185790	IC(MICOM)	(SERVICE)	D274	VE-30001285	DIODE SMD	
IC24	VE-30001468	IC		D275	VE-30007763	DIODE SMD	
IC25	VE-30019957	IC		D276	VE-30007763	DIODE SMD	
IC27	VE-30020052	IC		D277	VE-30001285	DIODE SMD	
IC28	VE-30021626	IC		D278	VE-30001285	DIODE SMD	
IC29	VE-30030108	IC		D279	VE-30001285	DIODE SMD	
IC30	VE-30014088	IC		D280	VE-30001285	DIODE SMD	
IC32	VE-30021943	IC		D600	VE-30001329	DIODE	
IC33	VE-20185355	IC(MICOM)	(SERVICE)	D602	VE-30001284	DIODE	
IC50	VE-30001670	PREAMPLIFIER TFMS5360		D603	VE-30001285	DIODE SMD	
IC100	VE-30014344	TRANSISTOR		D604	VE-30001285	DIODE SMD	
IC101	VE-30018326	IC		D605	VE-30001285	DIODE SMD	
IC102	VE-30023370	IC		D606	VE-30001285	DIODE SMD	
IC103	VE-30023369	IC		D700	VE-30001285	DIODE SMD	
IC105	VE-30018029	TRANSISTOR		D700	VE-30001329	DIODE	
IC106	VE-30018029	TRANSISTOR		D701	VE-30001285	DIODE SMD	
IC112	VE-30018358	IC		D701	VE-30001329	DIODE	
IC113	VE-30018006	IC		D710	VE-30003720	DIODE SMD	
IC114	VE-30019372	IC		D711	VE-30003720	DIODE SMD	
IC119	VE-30001665	IC		D950	VE-30001367	DIODE	
IC325	VE-30017956	IC					
IC375	VE-30017956	IC		C50	VE-30000413	E CAPACITOR	4.7uF 50V M
IC600	VE-30007739	IC		C100	VE-30000345	E CAPACITOR	10uF 50V M
IC650	VE-30017956	IC		C100	VE-30012576	CAPACITOR SMD	56pF 50V J CH
IC702	VE-30027663	IC		C100	VE-30012589	CAPACITOR SMD	4.7nF 50V K
Q100	VE-30001457	TRANSISTOR SMD		C101	VE-30000109	CAPACITOR MKT	470nF 63V J
Q101	VE-30001457	TRANSISTOR SMD		C101	VE-30012560	CAPACITOR SMD	100pF 50V J
Q101	VE-30007798	TRANSISTOR SMD		C101	VE-30012589	CAPACITOR SMD	4.7nF 50V K
Q102	VE-30001457	TRANSISTOR SMD		C102	VE-30000371	E CAPACITOR	22uF 50V M
Q102	VE-30007798	TRANSISTOR SMD		C102	VE-30012560	CAPACITOR SMD	100pF 50V J
Q103	VE-30001457	TRANSISTOR SMD		C102	VE-30012571	CAPACITOR SMD	39pF 50V J
Q103	VE-30007798	TRANSISTOR SMD		C103	VE-30000294	CAPACITOR SMD	100nF 50V K
Q104	VE-30001457	TRANSISTOR SMD		C103	VE-30012560	CAPACITOR SMD	100pF 50V J
Q104	VE-30001457	TRANSISTOR SMD		C103	VE-30012571	CAPACITOR SMD	39pF 50V J
Q106	VE-30001457	TRANSISTOR SMD		C104	VE-30000345	E CAPACITOR	10uF 50V M
Q106	VE-30007798	TRANSISTOR SMD		C104	VE-30012560	CAPACITOR SMD	100pF 50V J
Q106	VE-30001457	TRANSISTOR SMD		C104	VE-30012581	CAPACITOR SMD	1nF 50V K R
Q107	VE-30001457	TRANSISTOR SMD		C105	VE-30012560	CAPACITOR SMD	100pF 50V J
Q108	VE-30001457	TRANSISTOR SMD		C105	VE-30016654	CAPACITOR SMD	100nF 16V K R
Q108	VE-30007798	TRANSISTOR SMD		C105	VE-30016654	CAPACITOR SMD	100nF 16V K R
Q109	VE-30001457	TRANSISTOR SMD		C106	VE-30000352	E CAPACITOR	100uF 16V M
Q110	VE-30001457	TRANSISTOR SMD		C106	VE-30012603	CAPACITOR SMD	100nF 25V K R
Q111	VE-30001457	TRANSISTOR SMD		C107	VE-30012581	CAPACITOR SMD	1nF 50V K R
Q112	VE-30001457	TRANSISTOR SMD		C107	VE-30016654	CAPACITOR SMD	100nF 16V K R
Q113	VE-30001457	TRANSISTOR SMD		C108	VE-30000315	CAPACITOR SMD	220nF 25V Z
Q114	VE-30001457	TRANSISTOR SMD		C108	VE-30000352	E CAPACITOR	100uF 16V M
Q115	VE-30001457	TRANSISTOR SMD		C109	VE-30012569	CAPACITOR SMD	33pF 50V J
Q116	VE-30001458	TRANSISTOR SMD		C109	VE-30012610	CAPACITOR SMD	10nF 50V M
Q500	VE-30001457	TRANSISTOR SMD		C110	VE-30000345	E CAPACITOR	10uF 50V M
Q501	VE-30001457	TRANSISTOR SMD		C110	VE-30016654	CAPACITOR SMD	100nF 16V K R
Q502	VE-30001457	TRANSISTOR SMD		C111	VE-30000315	CAPACITOR SMD	220nF 25V Z
Q503	VE-30001457	TRANSISTOR SMD		C111	VE-30000359	E CAPACITOR	1000uF 16V M
Q504	VE-30001458	TRANSISTOR SMD		C112	VE-30012571	CAPACITOR SMD	39pF 50V J
Q505	VE-30001457	TRANSISTOR SMD		C113	VE-30000371	E CAPACITOR	22uF 50V M
Q506	VE-30001457	TRANSISTOR SMD		C114	VE-30000345	E CAPACITOR	10uF 50V M
Q507	VE-30001457	TRANSISTOR SMD		C115	VE-30012569	CAPACITOR SMD	33pF 50V J
Q508	VE-30001457	TRANSISTOR SMD		C116	VE-30000315	CAPACITOR SMD	220nF 25V Z
Q509	VE-30001457	TRANSISTOR SMD		C116	VE-30016654	CAPACITOR SMD	100nF 16V K R
Q600	VE-30001457	TRANSISTOR SMD		C117	VE-30000352	E CAPACITOR	100uF 16V M
Q601	VE-30001458	TRANSISTOR SMD		C117	VE-30000400	E CAPACITOR	47uF 50V M
Q602	VE-30001457	TRANSISTOR SMD		C118	VE-30012573	CAPACITOR SMD	47pF 50V J
Q703	VE-30001457	TRANSISTOR SMD		C118	VE-30012610	CAPACITOR SMD	10nF 50V J
Q704	VE-30001457	TRANSISTOR SMD		C119	VE-30012573	CAPACITOR SMD	47pF 50V J
Q705	VE-30001458	TRANSISTOR SMD		C119	VE-30016654	CAPACITOR SMD	100nF 16V K R
Q750	VE-30001458	TRANSISTOR SMD		C120	VE-30000315	CAPACITOR SMD	220nF 25V Z

△Ref No.	Part No.	Part Name	Description Local	△Ref No.	Part No.	Part Name	Description Local
C120	VE-30000359	E CAPACITOR	1000uF 16V M	C202	VE-30012581	CAPACITOR SMD	1nF 50V K R
C121	VE-30012581	CAPACITOR SMD	1nF 50V K R	C203	VE-30012581	CAPACITOR SMD	1nF 50V K R
C121	VE-30016654	CAPACITOR SMD	100nF 16V K R	C204	VE-30012581	CAPACITOR SMD	1nF 50V K R
C122	VE-30000352	E CAPACITOR	100uF 16V M	C205	VE-30012581	CAPACITOR SMD	1nF 50V K R
C123	VE-30012569	CAPACITOR SMD	33pF 50V J	C206	VE-30000345	E CAPACITOR	10uF 50V M
C123	VE-30016654	CAPACITOR SMD	100nF 16V K R	C207	VE-30000371	E CAPACITOR	22uF 50V M
C124	VE-30000352	E CAPACITOR	100uF 16V M	C208	VE-30016126	CAPACITOR SMD	220nF 16V K R
C124	VE-30012569	CAPACITOR SMD	33pF 50V J	C209	VE-30016126	CAPACITOR SMD	220nF 16V K R
C125	VE-30000359	E CAPACITOR	1000uF 16V M	C210	VE-30000393	E CAPACITOR	3.3uF 50V M
C125	VE-30012603	CAPACITOR SMD	100nF 25V K R	C211	VE-30012603	CAPACITOR SMD	100nF 25V K R
C126	VE-30000359	E CAPACITOR	1000uF 16V M	C212	VE-30012583	CAPACITOR SMD	1.5nF 50V K
C126	VE-30016126	CAPACITOR SMD	220nF 16V K R	C213	VE-30016126	CAPACITOR SMD	220nF 16V K R
C127	VE-30000359	E CAPACITOR	1000uF 16V M	C214	VE-30016126	CAPACITOR SMD	220nF 16V K R
C127	VE-30012582	CAPACITOR SMD	10nF 50V K R	C215	VE-30016126	CAPACITOR SMD	220nF 16V K R
C128	VE-30007748	E CAPACITOR	1000uF 35V M	C216	VE-30016126	CAPACITOR SMD	220nF 16V K R
C128	VE-30012572	CAPACITOR SMD	390pF 50V J	C217	VE-30016126	CAPACITOR SMD	220nF 16V K R
C129	VE-30000109	CAPACITOR MKT	470nF 63V J	C218	VE-30016126	CAPACITOR SMD	220nF 16V K R
C130	VE-30012610	CAPACITOR SMD	10nF 50V J	C219	VE-30016126	CAPACITOR SMD	220nF 16V K R
C131	VE-30000345	E CAPACITOR	10uF 50V M	C220	VE-30012577	CAPACITOR SMD	560pF 50V J
C132	VE-30000315	CAPACITOR SMD	220nF 25V Z	C221	VE-30000371	E CAPACITOR	22uF 50V M
C133	VE-30000315	CAPACITOR SMD	220nF 25V Z	C222	VE-30012574	CAPACITOR SMD	470pF 50V J
C134	VE-30012571	CAPACITOR SMD	39pF 50V J	C223	VE-30000352	E CAPACITOR	100uF 16V M
C135	VE-30012571	CAPACITOR SMD	39pF 50V J	C224	VE-30012583	CAPACITOR SMD	1.5nF 50V K
C136	VE-30012566	CAPACITOR SMD	22pF 50V J	C225	VE-30000345	E CAPACITOR	10uF 50V M
C137	VE-30016126	CAPACITOR SMD	220nF 16V K R	C226	VE-30012581	CAPACITOR SMD	1nF 50V K R
C138	VE-30000109	CAPACITOR MKT	470nF 63V J	C227	VE-30012576	CAPACITOR SMD	56pF 50V J CH
C139	VE-30012603	CAPACITOR SMD	100nF 25V K R	C229	VE-30000345	E CAPACITOR	10uF 50V M
C140	VE-30012583	CAPACITOR SMD	1.5nF 50V K	C230	VE-30012576	CAPACITOR SMD	56pF 50V J CH
C141	VE-30012582	CAPACITOR SMD	10nF 50V K R	C232	VE-30012576	CAPACITOR SMD	56pF 50V J CH
C142	VE-30000345	E CAPACITOR	10uF 50V M	C234	VE-30012565	CAPACITOR SMD	1.8pF 50V J CH
C144	VE-30012603	CAPACITOR SMD	100nF 25V K R	C235	VE-30012581	CAPACITOR SMD	1nF 50V K R
C145	VE-30000353	E CAPACITOR	100uF 25V M	C236	VE-30000371	E CAPACITOR	22uF 50V M
C146	VE-30012603	CAPACITOR SMD	100nF 25V K R	C237	VE-30012581	CAPACITOR SMD	1nF 50V K R
C147	VE-30012603	CAPACITOR SMD	100nF 25V K R	C238	VE-30012565	CAPACITOR SMD	1.8pF 50V J CH
C148	VE-30000100	CAPACITOR MKT	330nF 63V J	C239	VE-30012581	CAPACITOR SMD	1nF 50V K R
C149	VE-30012581	CAPACITOR SMD	1nF 50V K R	C240	VE-30012581	CAPACITOR SMD	1nF 50V K R
C150	VE-30012585	CAPACITOR SMD	2.2nF 50V K R	C241	VE-30000371	E CAPACITOR	22uF 50V M
C151	VE-30012585	CAPACITOR SMD	2.2nF 50V K R	C242	VE-30012581	CAPACITOR SMD	1nF 50V K R
C152	VE-30000396	E CAPACITOR	47uF 16V M	C243	VE-30012581	CAPACITOR SMD	1nF 50V K R
C153	VE-30000352	E CAPACITOR	100uF 16V M	C244	VE-30012581	CAPACITOR SMD	1nF 50V K R
C154	VE-30012576	CAPACITOR SMD	56pF 50V J CH	C245	VE-30012581	CAPACITOR SMD	1nF 50V K R
C155	VE-30012585	CAPACITOR SMD	2.2nF 50V K R	C246	VE-30012560	CAPACITOR SMD	100pF 50V J
C156	VE-30012581	CAPACITOR SMD	1nF 50V K R	C247	VE-30000371	E CAPACITOR	22uF 50V M
C157	VE-30012581	CAPACITOR SMD	1nF 50V K R	C248	VE-30000407	E CAPACITOR	470uF 16V M
C158	VE-30012603	CAPACITOR SMD	100nF 25V K R	C249	VE-30009208	C CAPACITOR	470pF 1KV K (PULSE)
C159	VE-30000109	CAPACITOR MKT	470nF 63V J	C250	VE-30012571	CAPACITOR SMD	39pF 50V J
C160	VE-30012569	CAPACITOR SMD	33pF 50V J	C251	VE-30012574	CAPACITOR SMD	470pF 50V J
C161	VE-30000345	E CAPACITOR	10uF 50V M	C252	VE-30012568	CAPACITOR SMD	270pF 50V J
C162	VE-30000345	E CAPACITOR	10uF 50V M	C253	VE-30012583	CAPACITOR SMD	1.5nF 50V K
C163	VE-30012581	CAPACITOR SMD	1nF 50V K R	C254	VE-30012571	CAPACITOR SMD	39pF 50V J
C164	VE-30012569	CAPACITOR SMD	33pF 50V J	C255	VE-30000345	E CAPACITOR	10uF 50V M
C165	VE-30000400	E CAPACITOR	47uF 50V M	C256	VE-30000352	E CAPACITOR	100uF 16V M
C166	VE-30012576	CAPACITOR SMD	56pF 50V J CH	C257	VE-30012560	CAPACITOR SMD	100pF 50V J
C167	VE-30000352	E CAPACITOR	100uF 16V M	C258	VE-30012560	CAPACITOR SMD	100pF 50V J
C168	VE-30012571	CAPACITOR SMD	39pF 50V J	C259	VE-30012608	CAPACITOR SMD	27pF 50V J CH
C169	VE-30012585	CAPACITOR SMD	2.2nF 50V K R	C260	VE-30012608	CAPACITOR SMD	27pF 50V J CH
C170	VE-30012571	CAPACITOR SMD	39pF 50V J	C261	VE-30012608	CAPACITOR SMD	27pF 50V J CH
C171	VE-30012569	CAPACITOR SMD	33pF 50V J	C265	VE-30012607	CAPACITOR SMD	150pF 50V J
C172	VE-30012569	CAPACITOR SMD	33pF 50V J	C266	VE-30012589	CAPACITOR SMD	4.7nF 50V K
C173	VE-30000074	CAPACITOR MKT	100nF 63V J	C267	VE-30012589	CAPACITOR SMD	4.7nF 50V K
C174	VE-30016126	CAPACITOR SMD	220nF 16V K R	C270	VE-30016654	CAPACITOR SMD	100nF 16V K R
C175	VE-30012582	CAPACITOR SMD	10nF 50V K R	C271	VE-30012589	CAPACITOR SMD	4.7nF 50V K
C176	VE-30012572	CAPACITOR SMD	390pF 50V J	C272	VE-30012589	CAPACITOR SMD	4.7nF 50V K
C177	VE-30000100	CAPACITOR MKT	330nF 63V J	C273	VE-30012589	CAPACITOR SMD	4.7nF 50V K
C178	VE-30000109	CAPACITOR MKT	470nF 63V J	C274	VE-30012607	CAPACITOR SMD	150pF 50V J
C179	VE-30012610	CAPACITOR SMD	10nF 50V J	C275	VE-30012589	CAPACITOR SMD	4.7nF 50V K
C180	VE-30000407	E CAPACITOR	470uF 16V M	C276	VE-30012589	CAPACITOR SMD	4.7nF 50V K
C181	VE-30016654	CAPACITOR SMD	100nF 16V K R	C277	VE-30012607	CAPACITOR SMD	150pF 50V J
C183	VE-30012581	CAPACITOR SMD	1nF 50V K R	C278	VE-30012607	CAPACITOR SMD	150pF 50V J
C184	VE-30000352	E CAPACITOR	100uF 16V M	C279	VE-30012589	CAPACITOR SMD	4.7nF 50V K
C185	VE-30012603	CAPACITOR SMD	100nF 25V K R	C280	VE-30012589	CAPACITOR SMD	4.7nF 50V K
C186	VE-30016654	CAPACITOR SMD	100nF 16V K R	C281	VE-30012589	CAPACITOR SMD	4.7nF 50V K
C187	VE-30012566	CAPACITOR SMD	22pF 50V J	C282	VE-30012607	CAPACITOR SMD	150pF 50V J
C188	VE-30016126	CAPACITOR SMD	220nF 16V K R	C283	VE-30012607	CAPACITOR SMD	150pF 50V J
C189	VE-30012581	CAPACITOR SMD	1nF 50V K R	C284	VE-30012607	CAPACITOR SMD	150pF 50V J
C190	VE-30000109	CAPACITOR MKT	470nF 63V J	C286	VE-30012607	CAPACITOR SMD	150pF 50V J
C191	VE-30016654	CAPACITOR SMD	100nF 16V K R	C288	VE-30012607	CAPACITOR SMD	150pF 50V J
C192	VE-30012583	CAPACITOR SMD	1.5nF 50V K	C291	VE-30012607	CAPACITOR SMD	150pF 50V J
C193	VE-30016654	CAPACITOR SMD	100nF 16V K R	C292	VE-30012581	CAPACITOR SMD	1nF 50V K R
C194	VE-30012582	CAPACITOR SMD	10nF 50V K R	C293	VE-30012589	CAPACITOR SMD	4.7nF 50V K
C195	VE-30000345	E CAPACITOR	10uF 50V M	C294	VE-30012581	CAPACITOR SMD	1nF 50V K R
C196	VE-30012581	CAPACITOR SMD	1nF 50V K R	C295	VE-30012607	CAPACITOR SMD	150pF 50V J
C197	VE-30012581	CAPACITOR SMD	1nF 50V K R	C296	VE-30012589	CAPACITOR SMD	4.7nF 50V K
C198	VE-30000345	E CAPACITOR	10uF 50V M	C297	VE-30012607	CAPACITOR SMD	150pF 50V J
C199	VE-30012603	CAPACITOR SMD	100nF 25V K R	C298	VE-30012607	CAPACITOR SMD	150pF 50V J
C200	VE-30012581	CAPACITOR SMD	1nF 50V K R	C299	VE-30012607	CAPACITOR SMD	150pF 50V J
C201	VE-30012581	CAPACITOR SMD	1nF 50V K R	C300	VE-30000400	E CAPACITOR	47uF 50V M

△Ref No.	Part No.	Part Name	Description Local	△Ref No.	Part No.	Part Name	Description Local
C301	VE-30016654	CAPACITOR SMD	100nF 16V K R	C500	VE-30012603	CAPACITOR SMD	100nF 25V K R
C302	VE-30012607	CAPACITOR SMD	150pF 50V J	C501	VE-30012603	CAPACITOR SMD	100nF 25V K R
C303	VE-30012607	CAPACITOR SMD	150pF 50V J	C502	VE-30012603	CAPACITOR SMD	100nF 25V K R
C304	VE-30012607	CAPACITOR SMD	150pF 50V J	C503	VE-30012603	CAPACITOR SMD	100nF 25V K R
C325	VE-30012571	CAPACITOR SMD	39pF 50V J	C504	VE-30012603	CAPACITOR SMD	100nF 25V K R
C326	VE-30012571	CAPACITOR SMD	39pF 50V J	C505	VE-30012603	CAPACITOR SMD	100nF 25V K R
C327	VE-30012602	CAPACITOR SMD	10nF 25V K R	C506	VE-30012603	CAPACITOR SMD	100nF 25V K R
C328	VE-30012590	CAPACITOR SMD	47nF 50V K	C507	VE-30012603	CAPACITOR SMD	100nF 25V K R
C329	VE-30012590	CAPACITOR SMD	47nF 50V K	C508	VE-30012603	CAPACITOR SMD	100nF 25V K R
C330	VE-30012590	CAPACITOR SMD	47nF 50V K	C509	VE-30012603	CAPACITOR SMD	100nF 25V K R
C331	VE-30012590	CAPACITOR SMD	47nF 50V K	C510	VE-30012603	CAPACITOR SMD	100nF 25V K R
C332	VE-30012590	CAPACITOR SMD	47nF 50V K	C511	VE-30012603	CAPACITOR SMD	100nF 25V K R
C333	VE-30012590	CAPACITOR SMD	47nF 50V K	C512	VE-30012603	CAPACITOR SMD	100nF 25V K R
C334	VE-30012590	CAPACITOR SMD	47nF 50V K	C513	VE-30012603	CAPACITOR SMD	100nF 25V K R
C335	VE-30012590	CAPACITOR SMD	47nF 50V K	C514	VE-30012603	CAPACITOR SMD	100nF 25V K R
C336	VE-30012606	CAPACITOR SMD	47nF 25V K R	C515	VE-30012603	CAPACITOR SMD	100nF 25V K R
C337	VE-30012590	CAPACITOR SMD	47nF 50V K	C516	VE-30000371	E CAPACITOR	22uF 50V M
C338	VE-30012590	CAPACITOR SMD	47nF 50V K	C517	VE-30012603	CAPACITOR SMD	100nF 25V K R
C339	VE-30000294	CAPACITOR SMD	100nF 50V K	C518	VE-30012610	CAPACITOR SMD	10nF 50V J
C340	VE-30000294	CAPACITOR SMD	100nF 50V K	C519	VE-30016654	CAPACITOR SMD	100nF 16V K R
C341	VE-30000294	CAPACITOR SMD	100nF 50V K	C520	VE-30012564	CAPACITOR SMD	18pF 50V J
C342	VE-30000294	CAPACITOR SMD	100nF 50V K	C521	VE-30016654	CAPACITOR SMD	100nF 16V K R
C343	VE-30000294	CAPACITOR SMD	100nF 50V K	C522	VE-30012564	CAPACITOR SMD	18pF 50V J
C344	VE-30000294	CAPACITOR SMD	100nF 50V K	C523	VE-30000362	E CAPACITOR	1uF 50V M
C345	VE-30000294	CAPACITOR SMD	100nF 50V K	C524	VE-30016654	CAPACITOR SMD	100nF 16V K R
C346	VE-30000294	CAPACITOR SMD	100nF 50V K	C525	VE-30000362	E CAPACITOR	1uF 50V M
C347	VE-30000294	CAPACITOR SMD	100nF 50V K	C526	VE-30000345	E CAPACITOR	10uF 50V M
C348	VE-30000294	CAPACITOR SMD	100nF 50V K	C527	VE-30016654	CAPACITOR SMD	100nF 16V K R
C349	VE-30000294	CAPACITOR SMD	100nF 50V K	C528	VE-30012603	CAPACITOR SMD	100nF 25V K R
C350	VE-30000294	CAPACITOR SMD	100nF 50V K	C529	VE-30000371	E CAPACITOR	22uF 50V M
C351	VE-30016654	CAPACITOR SMD	100nF 16V K R	C530	VE-30000371	E CAPACITOR	22uF 50V M
C352	VE-30000353	E CAPACITOR	100uF 25V M	C531	VE-30000345	E CAPACITOR	10uF 50V M
C353	VE-30016654	CAPACITOR SMD	100nF 16V K R	C532	VE-30000345	E CAPACITOR	10uF 50V M
C354	VE-30000352	E CAPACITOR	100uF 16V M	C533	VE-30012603	CAPACITOR SMD	100nF 25V K R
C355	VE-30000352	E CAPACITOR	100uF 16V M	C534	VE-30012603	CAPACITOR SMD	100nF 25V K R
C375	VE-30010571	E CAPACITOR	10uF 16V M	C535	VE-30012603	CAPACITOR SMD	100nF 25V K R
C376	VE-30012603	CAPACITOR SMD	100nF 25V K R	C536	VE-30012603	CAPACITOR SMD	100nF 25V K R
C377	VE-30012603	CAPACITOR SMD	100nF 25V K R	C537	VE-30016654	CAPACITOR SMD	100nF 16V K R
C378	VE-30012603	CAPACITOR SMD	100nF 25V K R	C539	VE-30012577	CAPACITOR SMD	560pF 50V J
C379	VE-30012603	CAPACITOR SMD	100nF 25V K R	C540	VE-30000352	E CAPACITOR	100uF 16V M
C380	VE-30000371	E CAPACITOR	22uF 50V M	C541	VE-30012603	CAPACITOR SMD	100nF 25V K R
C381	VE-30012603	CAPACITOR SMD	100nF 25V K R	C542	VE-30012603	CAPACITOR SMD	100nF 25V K R
C382	VE-30012603	CAPACITOR SMD	100nF 25V K R	C600	VE-30000359	E CAPACITOR	1000uF 16V M
C383	VE-30012590	CAPACITOR SMD	47nF 50V K	C601	VE-30000359	E CAPACITOR	1000uF 16V M
C384	VE-30012603	CAPACITOR SMD	100nF 25V K R	C602	VE-30012609	CAPACITOR SMD	68nF 50V K
C385	VE-30012603	CAPACITOR SMD	100nF 25V K R	C603	VE-30000353	E CAPACITOR	100uF 25V M
C386	VE-30012603	CAPACITOR SMD	100nF 25V K R	C604	VE-30016654	CAPACITOR SMD	100nF 16V K R
C387	VE-30012581	CAPACITOR SMD	1nF 50V K R	C606	VE-30012603	CAPACITOR SMD	100nF 25V K R
C388	VE-30012590	CAPACITOR SMD	47nF 50V K	C607	VE-30000362	E CAPACITOR	1uF 50V M
C389	VE-30012603	CAPACITOR SMD	100nF 25V K R	C608	VE-30012603	CAPACITOR SMD	100nF 25V K R
C390	VE-30012603	CAPACITOR SMD	100nF 25V K R	C609	VE-30012587	CAPACITOR SMD	3.3nF 50V K
C391	VE-30012590	CAPACITOR SMD	47nF 50V K	C610	VE-30000400	E CAPACITOR	47uF 50V M
C392	VE-30012603	CAPACITOR SMD	100nF 25V K R	C611	VE-30012603	CAPACITOR SMD	100nF 25V K R
C393	VE-30012603	CAPACITOR SMD	100nF 25V K R	C612	VE-30000359	E CAPACITOR	1000uF 16V M
C394	VE-30012603	CAPACITOR SMD	100nF 25V K R	C613	VE-30000400	E CAPACITOR	47uF 50V M
C395	VE-30012603	CAPACITOR SMD	100nF 25V K R	C614	VE-30000316	C CAPACITOR	220nF 25V Z F
C396	VE-30012603	CAPACITOR SMD	100nF 25V K R	C615	VE-30012603	CAPACITOR SMD	100nF 25V K R
C397	VE-30012603	CAPACITOR SMD	100nF 25V K R	C616	VE-30000362	E CAPACITOR	1uF 50V M
C398	VE-30012603	CAPACITOR SMD	100nF 25V K R	C617	VE-30000352	E CAPACITOR	100uF 16V M
C399	VE-30000353	E CAPACITOR	100uF 25V M	C618	VE-30000352	E CAPACITOR	100uF 16V M
C400	VE-30000353	E CAPACITOR	100uF 25V M	C650	VE-30012602	CAPACITOR SMD	10nF 25V K R
C401	VE-30012587	CAPACITOR SMD	3.3nF 50V K	C651	VE-30012571	CAPACITOR SMD	39pF 50V J
C402	VE-30012588	CAPACITOR SMD	33nF 50V K	C652	VE-30012571	CAPACITOR SMD	39pF 50V J
C403	VE-30016654	CAPACITOR SMD	100nF 16V K R	C653	VE-30012590	CAPACITOR SMD	47nF 50V K
C404	VE-30000352	E CAPACITOR	100uF 16V M	C654	VE-30012590	CAPACITOR SMD	47nF 50V K
C405	VE-30000352	E CAPACITOR	100uF 16V M	C655	VE-30012590	CAPACITOR SMD	47nF 50V K
C406	VE-30016654	CAPACITOR SMD	100nF 16V K R	C656	VE-30012590	CAPACITOR SMD	47nF 50V K
C450	VE-30000345	E CAPACITOR	10uF 50V M	C657	VE-30012590	CAPACITOR SMD	47nF 50V K
C451	VE-30012570	CAPACITOR SMD	330pF 50V J	C658	VE-30012590	CAPACITOR SMD	47nF 50V K
C452	VE-30000345	E CAPACITOR	10uF 50V M	C659	VE-30012606	CAPACITOR SMD	47nF 25V K R
C453	VE-30012570	CAPACITOR SMD	330pF 50V J	C660	VE-30012590	CAPACITOR SMD	47nF 50V K
C454	VE-30012570	CAPACITOR SMD	330pF 50V J	C661	VE-30012590	CAPACITOR SMD	47nF 50V K
C455	VE-30012560	CAPACITOR SMD	100pF 50V J	C662	VE-30012590	CAPACITOR SMD	47nF 50V K
C456	VE-30012560	CAPACITOR SMD	100pF 50V J	C663	VE-30012606	CAPACITOR SMD	47nF 25V K R
C457	VE-30012570	CAPACITOR SMD	330pF 50V J	C664	VE-30000294	CAPACITOR SMD	100nF 50V K
C458	VE-30012570	CAPACITOR SMD	330pF 50V J	C665	VE-30000294	CAPACITOR SMD	100nF 50V K
C459	VE-30012570	CAPACITOR SMD	330pF 50V J	C666	VE-30000294	CAPACITOR SMD	100nF 50V K
C460	VE-30012560	CAPACITOR SMD	100pF 50V J	C667	VE-30000294	CAPACITOR SMD	100nF 50V K
C461	VE-30012560	CAPACITOR SMD	100pF 50V J	C668	VE-30000294	CAPACITOR SMD	100nF 50V K
C462	VE-30012570	CAPACITOR SMD	330pF 50V J	C669	VE-30000294	CAPACITOR SMD	100nF 50V K
C463	VE-30000345	E CAPACITOR	10uF 50V M	C670	VE-30000294	CAPACITOR SMD	100nF 50V K
C464	VE-30012560	CAPACITOR SMD	100pF 50V J	C671	VE-30000294	CAPACITOR SMD	100nF 50V K
C465	VE-30012570	CAPACITOR SMD	330pF 50V J	C672	VE-30000294	CAPACITOR SMD	100nF 50V K
C466	VE-30012570	CAPACITOR SMD	330pF 50V J	C673	VE-30000294	CAPACITOR SMD	100nF 50V K
C467	VE-30012570	CAPACITOR SMD	330pF 50V J	C674	VE-30000294	CAPACITOR SMD	100nF 50V K
C468	VE-30012570	CAPACITOR SMD	330pF 50V J	C675	VE-30000294	CAPACITOR SMD	100nF 50V K
C469	VE-30012603	CAPACITOR SMD	100nF 25V K R	C676	VE-30000294	CAPACITOR SMD	100nF 50V K

△Ref No.	Part No.	Part Name	Description Local	△Ref No.	Part No.	Part Name	Description Local
C677	VE-30016654	CAPACITOR SMD	100nF 16V K R	R101	VE-30012713	RESISTOR SMD	1/16W 75R J
C678	VE-30000353	E CAPACITOR	100uF 25V M	R101	VE-30012986	RESISTOR SMD	1/16W 68R J
C679	VE-30016654	CAPACITOR SMD	100nF 16V K R	R101	VE-30014022	RESISTOR SMD	1/16W 47R J
C680	VE-30000352	E CAPACITOR	100uF 16V M	R102	VE-30012641	RESISTOR SMD	1/16W 10K J
C681	VE-30000352	E CAPACITOR	100uF 16V M	R102	VE-30012713	RESISTOR SMD	1/16W 75R J
C700	VE-30012603	CAPACITOR SMD	100nF 25V K R	R102	VE-30012986	RESISTOR SMD	1/16W 68R J
C701	VE-30012603	CAPACITOR SMD	100nF 25V K R	R103	VE-30012641	RESISTOR SMD	1/16W 10K J
C702	VE-30012603	CAPACITOR SMD	100nF 25V K R	R103	VE-30012659	RESISTOR SMD	1/16W 2.2K J
C703	VE-30012603	CAPACITOR SMD	100nF 25V K R	R103	VE-30012713	RESISTOR SMD	1/16W 75R J
C704	VE-30012603	CAPACITOR SMD	100nF 25V K R	R104	VE-30012659	RESISTOR SMD	1/16W 2.2K J
C705	VE-30012564	CAPACITOR SMD	18pF 50V J	R104	VE-30012669	RESISTOR SMD	1/16W 22K J
C706	VE-30012564	CAPACITOR SMD	18pF 50V J	R105	VE-30012510	RESISTOR SMD	1/16W 100R J
C707	VE-30012603	CAPACITOR SMD	100nF 25V K R	R105	VE-30012695	RESISTOR SMD	1/16W 470R J
C708	VE-30012603	CAPACITOR SMD	100nF 25V K R	R105	VE-30012703	RESISTOR SMD	1/16W 56K J
C709	VE-30012603	CAPACITOR SMD	100nF 25V K R	R106	VE-30012510	RESISTOR SMD	1/16W 100R J
C710	VE-30012603	CAPACITOR SMD	100nF 25V K R	R106	VE-30012669	RESISTOR SMD	1/16W 22K J
C711	VE-30012603	CAPACITOR SMD	100nF 25V K R	R106	VE-30012677	RESISTOR SMD	1/16W 3.3K J
C712	VE-30012603	CAPACITOR SMD	100nF 25V K R	R107	VE-30012510	RESISTOR SMD	1/16W 100R J
C713	VE-30012610	CAPACITOR SMD	10nF 50V J	R107	VE-30012695	RESISTOR SMD	1/16W 470R J
C714	VE-30000345	E CAPACITOR	10uF 50V M	R108	VE-30012510	RESISTOR SMD	1/16W 100R J
C715	VE-30012610	CAPACITOR SMD	10nF 50V J	R108	VE-30014022	RESISTOR SMD	1/16W 47R J
C726	VE-30016654	CAPACITOR SMD	100nF 16V K R	R109	VE-30012510	RESISTOR SMD	1/16W 100R J
C727	VE-30016654	CAPACITOR SMD	100nF 16V K R	R109	VE-30014022	RESISTOR SMD	1/16W 47R J
C728	VE-30000353	E CAPACITOR	100uF 25V M	R110	VE-30012510	RESISTOR SMD	1/16W 100R J
C729	VE-30000353	E CAPACITOR	100uF 25V M	R110	VE-30012641	RESISTOR SMD	1/16W 10K J
C741	VE-30000353	E CAPACITOR	100uF 25V M	R111	VE-30012641	RESISTOR SMD	1/16W 10K J
C742	VE-30000353	E CAPACITOR	100uF 25V M	R111	VE-30012698	RESISTOR SMD	1/16W 5.6K J
C743	VE-30000353	E CAPACITOR	100uF 25V M	R112	VE-30012510	RESISTOR SMD	1/16W 100R J
C744	VE-30000353	E CAPACITOR	100uF 25V M	R112	VE-30012510	RESISTOR SMD	1/16W 100R J
C745	VE-30000353	E CAPACITOR	100uF 25V M	R113	VE-30012510	RESISTOR SMD	1/16W 100R J
C751	VE-30000355	E CAPACITOR	100uF 50V M	R113	VE-30012685	RESISTOR SMD	1/16W 33K J
C752	VE-30000237	CAPACITOR SMD	33pF 50V J	R114	VE-30012641	RESISTOR SMD	1/16W 10K J
C753	VE-30000294	CAPACITOR SMD	100nF 50V K	R114	VE-30012705	RESISTOR SMD	1/16W 6.8K J
C754	VE-30000294	CAPACITOR SMD	100nF 50V K	R115	VE-30012651	RESISTOR SMD	1/16W 160K J
C755	VE-30000355	E CAPACITOR	100uF 50V M	R115	VE-30012659	RESISTOR SMD	1/16W 2.2K J
C756	VE-30000294	CAPACITOR SMD	100nF 50V K	R116	VE-30000721	RESISTOR SMD	1/10W 4.7K J
C757	VE-30000345	E CAPACITOR	10uF 50V M	R116	VE-30012657	RESISTOR SMD	1/16W 1K J
C758	VE-30000209	CAPACITOR SMD	18pF 50V J	R117	VE-30000721	RESISTOR SMD	1/10W 4.7K J
C759	VE-30000209	CAPACITOR SMD	18pF 50V J	R117	VE-30012641	RESISTOR SMD	1/16W 10K J
C760	VE-30000294	CAPACITOR SMD	100nF 50V K	R118	VE-30012641	RESISTOR SMD	1/16W 10K J
C761	VE-30000294	CAPACITOR SMD	100nF 50V K	R118	VE-30013001	RESISTOR SMD	1/16W 1K F
C762	VE-30000294	CAPACITOR SMD	100nF 50V K	R119	VE-30012641	RESISTOR SMD	1/16W 10K J
C763	VE-30000294	CAPACITOR SMD	100nF 50V K	R119	VE-30012692	RESISTOR SMD	1/16W 4.7K J
C764	VE-30000294	CAPACITOR SMD	100nF 50V K	R120	VE-30012641	RESISTOR SMD	1/16W 10K J
C765	VE-30000294	CAPACITOR SMD	100nF 50V K	R120	VE-30012641	RESISTOR SMD	1/16W 10K J
C775	VE-30000376	E CAPACITOR	220uF 25V M	R121	VE-30012641	RESISTOR SMD	1/16W 10K J
C776	VE-30020694	CAPACITOR SMD	1uF 16V Z Y5V	R122	VE-30014420	RESISTOR SMD	1/16W 10K F
C777	VE-30000294	CAPACITOR SMD	100nF 50V K	R123	VE-30012510	RESISTOR SMD	1/16W 100R J
C778	VE-30000294	CAPACITOR SMD	100nF 50V K	R124	VE-30012510	RESISTOR SMD	1/16W 100R J
C779	VE-30012567	CAPACITOR SMD	220pF 50V J	R124	VE-30012641	RESISTOR SMD	1/16W 10K J
C780	VE-30012610	CAPACITOR SMD	10nF 50V J	R125	VE-30012641	RESISTOR SMD	1/16W 10K J
C781	VE-30012610	CAPACITOR SMD	10nF 50V J	R125	VE-30014022	RESISTOR SMD	1/16W 47R J
C782	VE-30000294	CAPACITOR SMD	100nF 50V K	R126	VE-30012510	RESISTOR SMD	1/16W 100R J
C783	VE-30000294	CAPACITOR SMD	100nF 50V K	R127	VE-30012510	RESISTOR SMD	1/16W 100R J
C784	VE-30000376	E CAPACITOR	220uF 25V M	R127	VE-30012713	RESISTOR SMD	1/16W 75R J
C785	VE-30012581	CAPACITOR SMD	1nF 50V K R	R128	VE-30012669	RESISTOR SMD	1/16W 22K J
C786	VE-30012581	CAPACITOR SMD	1nF 50V K R	R129	VE-30012705	RESISTOR SMD	1/16W 6.8K J
C787	VE-30020694	CAPACITOR SMD	1uF 16V Z Y5V	R130	VE-30012657	RESISTOR SMD	1/16W 1K J
C788	VE-30020694	CAPACITOR SMD	1uF 16V Z Y5V	R131	VE-30012510	RESISTOR SMD	1/16W 100R J
C789	VE-30020694	CAPACITOR SMD	1uF 16V Z Y5V	R131	VE-30012641	RESISTOR SMD	1/16W 10K J
C790	VE-30020694	CAPACITOR SMD	1uF 16V Z Y5V	R132	VE-30012641	RESISTOR SMD	1/16W 10K J
C791	VE-30020694	CAPACITOR SMD	1uF 16V Z Y5V	R132	VE-30012713	RESISTOR SMD	1/16W 75R J
C792	VE-30020694	CAPACITOR SMD	1uF 16V Z Y5V	R133	VE-30012510	RESISTOR SMD	1/16W 100R J
C793	VE-30012610	CAPACITOR SMD	10nF 50V J	R133	VE-30012669	RESISTOR SMD	1/16W 22K J
C794	VE-30012610	CAPACITOR SMD	10nF 50V J	R134	VE-30012510	RESISTOR SMD	1/16W 100R J
C795	VE-30012581	CAPACITOR SMD	1nF 50V K R	R135	VE-30012510	RESISTOR SMD	1/16W 100R J
C796	VE-30012581	CAPACITOR SMD	1nF 50V K R	R136	VE-30012713	RESISTOR SMD	1/16W 75R J
C800	VE-30000294	CAPACITOR SMD	100nF 50V K	R137	VE-30012657	RESISTOR SMD	1/16W 1K J
C801	VE-30000294	CAPACITOR SMD	100nF 50V K	R138	VE-30012713	RESISTOR SMD	1/16W 75R J
C802	VE-30000294	CAPACITOR SMD	100nF 50V K	R139	VE-30012713	RESISTOR SMD	1/16W 75R J
C803	VE-30000376	E CAPACITOR	220uF 25V M	R140	VE-30012657	RESISTOR SMD	1/16W 1K J
C804	VE-30000353	E CAPACITOR	100uF 25V M	R142	VE-30012713	RESISTOR SMD	1/16W 75R J
C805	VE-30000109	CAPACITOR MKT	470nF 63V J	R143	VE-30012657	RESISTOR SMD	1/16W 1K J
C806	VE-30000109	CAPACITOR MKT	470nF 63V J	R144	VE-30012644	RESISTOR SMD	1/16W 12K J
C807	VE-30000109	CAPACITOR MKT	470nF 63V J	R145	VE-30012668	RESISTOR SMD	1/16W 220R J
C808	VE-30000109	CAPACITOR MKT	470nF 63V J	R146	VE-30012657	RESISTOR SMD	1/16W 1K J
C809	VE-30033474	E CAPACITOR	2200uF 16V M (13x21)	R147	VE-30012657	RESISTOR SMD	1/16W 1K J
C810	VE-30033474	E CAPACITOR	2200uF 16V M (13x21)	R148	VE-30012644	RESISTOR SMD	1/16W 12K J
C990	VE-30000237	CAPACITOR SMD	33pF 50V J	R149	VE-30012703	RESISTOR SMD	1/16W 56K J
R1	VE-30000460	RESISTOR CF	1/4W 100R G	R150	VE-30012649	RESISTOR SMD	1/16W 150R J
R2	VE-30000460	RESISTOR CF	1/4W 100R G	R151	VE-30012641	RESISTOR SMD	1/16W 10K J
R50	VE-30000459	RESISTOR CF	1/4W 100R J	R152	VE-30012713	RESISTOR SMD	1/16W 75R J
R100	VE-30012655	RESISTOR SMD	1/16W 180R J	R153	VE-30012657	RESISTOR SMD	1/16W 1K J
R100	VE-30014022	RESISTOR SMD	1/16W 47R J	R154	VE-30012713	RESISTOR SMD	1/16W 75R J
R100	VE-30014076	RESISTOR SMD	1/16W 4.7R J	R155	VE-30014022	RESISTOR SMD	1/16W 47R J
△R100	VE-30018085	CAPACITOR VAR	SAFE 510V K	R156	VE-30012641	RESISTOR SMD	1/16W 10K J
				R157	VE-30012692	RESISTOR SMD	1/16W 4.7K J

△Ref No.	Part No.	Part Name	Description Local	△Ref No.	Part No.	Part Name	Description Local
R158	VE-30012651	RESISTOR SMD	1/16W 160K J	R300	VE-30012713	RESISTOR SMD	1/16W 75R J
R159	VE-30012669	RESISTOR SMD	1/16W 22K J	R301	VE-30012510	RESISTOR SMD	1/16W 100R J
R160	VE-30012713	RESISTOR SMD	1/16W 75R J	R302	VE-30012713	RESISTOR SMD	1/16W 75R J
R161	VE-30012510	RESISTOR SMD	1/16W 100R J	R304	VE-30012713	RESISTOR SMD	1/16W 75R J
R162	VE-30012510	RESISTOR SMD	1/16W 100R J	R325	VE-30012692	RESISTOR SMD	1/16W 4.7K J
R163	VE-30012510	RESISTOR SMD	1/16W 100R J	R326	VE-30014022	RESISTOR SMD	1/16W 47R J
R164	VE-30012510	RESISTOR SMD	1/16W 100R J	R327	VE-30012510	RESISTOR SMD	1/16W 100R J
R165	VE-30012651	RESISTOR SMD	1/16W 160K J	R328	VE-30012510	RESISTOR SMD	1/16W 100R J
R166	VE-30012698	RESISTOR SMD	1/16W 5.6K J	R329	VE-30017653	RESISTOR SARRAY	1/16W 47RX4 J
R167	VE-30012641	RESISTOR SMD	1/16W 10K J	R330	VE-30012987	RESISTOR SMD	1/16W 56R J
R168	VE-30012510	RESISTOR SMD	1/16W 100R J	R331	VE-30017653	RESISTOR SARRAY	1/16W 47RX4 J
R169	VE-30012692	RESISTOR SMD	1/16W 4.7K J	R332	VE-30014078	RESISTOR SMD	1/16W 22R J
R170	VE-30012679	RESISTOR SMD	1/16W 3.9K J	R333	VE-30012987	RESISTOR SMD	1/16W 56R J
R171	VE-30012679	RESISTOR SMD	1/16W 3.9K J	R334	VE-30017653	RESISTOR SARRAY	1/16W 47RX4 J
R172	VE-30013001	RESISTOR SMD	1/16W 1K F	R335	VE-30014078	RESISTOR SMD	1/16W 22R J
R173	VE-30012650	RESISTOR SMD	1/16W 15K J	R336	VE-30012987	RESISTOR SMD	1/16W 56R J
R174	VE-30012705	RESISTOR SMD	1/16W 6.8K J	R337	VE-30017653	RESISTOR SARRAY	1/16W 47RX4 J
R175	VE-30012679	RESISTOR SMD	1/16W 3.9K J	R338	VE-30014078	RESISTOR SMD	1/16W 22R J
R176	VE-30012669	RESISTOR SMD	1/16W 22K J	R339	VE-30014078	RESISTOR SMD	1/16W 22R J
R177	VE-30012705	RESISTOR SMD	1/16W 6.8K J	R340	VE-30017653	RESISTOR SARRAY	1/16W 47RX4 J
R178	VE-30012659	RESISTOR SMD	1/16W 2.2K J	R341	VE-30014078	RESISTOR SMD	1/16W 22R J
R179	VE-30012648	RESISTOR SMD	1/16W 150K J	R342	VE-30014078	RESISTOR SMD	1/16W 22R J
R180	VE-30012650	RESISTOR SMD	1/16W 15K J	R343	VE-30014078	RESISTOR SMD	1/16W 22R J
R181	VE-30012648	RESISTOR SMD	1/16W 150K J	R344	VE-30012987	RESISTOR SMD	1/16W 56R J
R182	VE-30012657	RESISTOR SMD	1/16W 1K J	R345	VE-30012987	RESISTOR SMD	1/16W 56R J
R184	VE-30012510	RESISTOR SMD	1/16W 100R J	R346	VE-30012987	RESISTOR SMD	1/16W 56R J
R185	VE-30012669	RESISTOR SMD	1/16W 22K J	R347	VE-30012987	RESISTOR SMD	1/16W 56R J
R186	VE-30012644	RESISTOR SMD	1/16W 12K J	R375	VE-30018372	RESISTOR SARRAY	1/16W 22R J
R187	VE-30012644	RESISTOR SMD	1/16W 12K J	R376	VE-30018372	RESISTOR SARRAY	1/16W 22R J
R188	VE-30012703	RESISTOR SMD	1/16W 56K J	R377	VE-30017653	RESISTOR SARRAY	1/16W 47RX4 J
R189	VE-30012649	RESISTOR SMD	1/16W 150R J	R378	VE-30018372	RESISTOR SARRAY	1/16W 22R J
R190	VE-30012668	RESISTOR SMD	1/16W 220R J	R379	VE-30018372	RESISTOR SARRAY	1/16W 22R J
R191	VE-30012713	RESISTOR SMD	1/16W 75R J	R380	VE-30018372	RESISTOR SARRAY	1/16W 22R J
R192	VE-30012657	RESISTOR SMD	1/16W 1K J	R381	VE-30018372	RESISTOR SARRAY	1/16W 22R J
R193	VE-30012657	RESISTOR SMD	1/16W 1K J	R382	VE-30012677	RESISTOR SMD	1/16W 3.3K J
R194	VE-30012657	RESISTOR SMD	1/16W 1K J	R457	VE-30014022	RESISTOR SMD	1/16W 47R J
R195	VE-30012657	RESISTOR SMD	1/16W 1K J	R459	VE-30012688	RESISTOR SMD	1/16W 390R J
R196	VE-30012657	RESISTOR SMD	1/16W 1K J	R465	VE-30012692	RESISTOR SMD	1/16W 4.7K J
R197	VE-30012657	RESISTOR SMD	1/16W 1K J	R466	VE-30012641	RESISTOR SMD	1/16W 10K J
R198	VE-30012657	RESISTOR SMD	1/16W 1K J	R467	VE-30012692	RESISTOR SMD	1/16W 4.7K J
R199	VE-30012657	RESISTOR SMD	1/16W 1K J	R468	VE-30012641	RESISTOR SMD	1/16W 10K J
R200	VE-30013001	RESISTOR SMD	1/16W 1K F	R469	VE-30012692	RESISTOR SMD	1/16W 4.7K J
R201	VE-30012510	RESISTOR SMD	1/16W 100R J	R470	VE-30012692	RESISTOR SMD	1/16W 4.7K J
R202	VE-30013001	RESISTOR SMD	1/16W 1K F	R471	VE-30012692	RESISTOR SMD	1/16W 4.7K J
R203	VE-30013001	RESISTOR SMD	1/16W 1K F	R472	VE-30012692	RESISTOR SMD	1/16W 4.7K J
R204	VE-30012510	RESISTOR SMD	1/16W 100R J	R500	VE-30012692	RESISTOR SMD	1/16W 4.7K J
R205	VE-30012510	RESISTOR SMD	1/16W 100R J	R501	VE-30012509	RESISTOR SMD	1/16W 100K J
R206	VE-30012510	RESISTOR SMD	1/16W 100R J	R502	VE-30012641	RESISTOR SMD	1/16W 10K J
R207	VE-30013001	RESISTOR SMD	1/16W 1K F	R503	VE-30012641	RESISTOR SMD	1/16W 10K J
R208	VE-30012510	RESISTOR SMD	1/16W 100R J	R504	VE-30014420	RESISTOR SMD	1/16W 10K F
R209	VE-30012510	RESISTOR SMD	1/16W 100R J	R505	VE-30014420	RESISTOR SMD	1/16W 10K F
R210	VE-30012657	RESISTOR SMD	1/16W 1K J	R506	VE-30012641	RESISTOR SMD	1/16W 10K J
R211	VE-30012510	RESISTOR SMD	1/16W 100R J	R507	VE-30012668	RESISTOR SMD	1/16W 220R J
R212	VE-30012657	RESISTOR SMD	1/16W 1K J	R508	VE-30014420	RESISTOR SMD	1/16W 10K F
R213	VE-30012657	RESISTOR SMD	1/16W 1K J	R509	VE-30014420	RESISTOR SMD	1/16W 10K F
R214	VE-30012510	RESISTOR SMD	1/16W 100R J	R510	VE-30030692	FERRITE NET	120R/100MHz 150mA
R215	VE-30012510	RESISTOR SMD	1/16W 100R J	R511	VE-30030692	FERRITE NET	120R/100MHz 150mA
R216	VE-30012695	RESISTOR SMD	1/16W 470R J	R512	VE-30012658	RESISTOR SMD	1/16W 1M J
R217	VE-30012695	RESISTOR SMD	1/16W 470R J	R513	VE-30030692	FERRITE NET	120R/100MHz 150mA
R218	VE-30012510	RESISTOR SMD	1/16W 100R J	R514	VE-30030692	FERRITE NET	120R/100MHz 150mA
R219	VE-30012510	RESISTOR SMD	1/16W 100R J	R515	VE-30012692	RESISTOR SMD	1/16W 4.7K J
R265	VE-30012713	RESISTOR SMD	1/16W 75R J	R516	VE-30012692	RESISTOR SMD	1/16W 4.7K J
R266	VE-30014078	RESISTOR SMD	1/16W 22R J	R517	VE-30030692	FERRITE NET	120R/100MHz 150mA
R267	VE-30012713	RESISTOR SMD	1/16W 75R J	R518	VE-30014420	RESISTOR SMD	1/16W 10K F
R268	VE-30012713	RESISTOR SMD	1/16W 75R J	R519	VE-30030692	FERRITE NET	120R/100MHz 150mA
R274	VE-30014078	RESISTOR SMD	1/16W 22R J	R520	VE-30012692	RESISTOR SMD	1/16W 4.7K J
R275	VE-30014078	RESISTOR SMD	1/16W 22R J	R521	VE-30014128	RESISTOR SMD	1/16W 33R J
R276	VE-30014078	RESISTOR SMD	1/16W 22R J	R522	VE-30012692	RESISTOR SMD	1/16W 4.7K J
R277	VE-30012675	RESISTOR SMD	1/16W 2K J	R523	VE-30012641	RESISTOR SMD	1/16W 10K J
R278	VE-30012675	RESISTOR SMD	1/16W 2K J	R524	VE-30012692	RESISTOR SMD	1/16W 4.7K J
R279	VE-30012707	RESISTOR SMD	1/16W 680R J	R525	VE-30017653	RESISTOR SARRAY	1/16W 47RX4 J
R280	VE-30012707	RESISTOR SMD	1/16W 680R J	R526	VE-30012668	RESISTOR SMD	1/16W 220R J
R281	VE-30012510	RESISTOR SMD	1/16W 100R J	R527	VE-30012668	RESISTOR SMD	1/16W 220R J
R282	VE-30012510	RESISTOR SMD	1/16W 100R J	R528	VE-30012641	RESISTOR SMD	1/16W 10K J
R283	VE-30012641	RESISTOR SMD	1/16W 10K J	R529	VE-30012692	RESISTOR SMD	1/16W 4.7K J
R284	VE-30012641	RESISTOR SMD	1/16W 10K J	R530	VE-30012692	RESISTOR SMD	1/16W 4.7K J
R285	VE-30012510	RESISTOR SMD	1/16W 100R J	R531	VE-30012692	RESISTOR SMD	1/16W 4.7K J
R286	VE-30012713	RESISTOR SMD	1/16W 75R J	R532	VE-30012692	RESISTOR SMD	1/16W 4.7K J
R289	VE-30012713	RESISTOR SMD	1/16W 75R J	R533	VE-30012692	RESISTOR SMD	1/16W 4.7K J
R290	VE-30012707	RESISTOR SMD	1/16W 680R J	R534	VE-30013001	RESISTOR SMD	1/16W 1K F
R291	VE-30012713	RESISTOR SMD	1/16W 75R J	R535	VE-30012692	RESISTOR SMD	1/16W 4.7K J
R292	VE-30012713	RESISTOR SMD	1/16W 75R J	R536	VE-30012692	RESISTOR SMD	1/16W 4.7K J
R295	VE-30012713	RESISTOR SMD	1/16W 75R J	R537	VE-30012692	RESISTOR SMD	1/16W 4.7K J
R296	VE-30012713	RESISTOR SMD	1/16W 75R J	R538	VE-30012692	RESISTOR SMD	1/16W 4.7K J
R297	VE-30012707	RESISTOR SMD	1/16W 680R J	R539	VE-30012692	RESISTOR SMD	1/16W 4.7K J
R298	VE-30012713	RESISTOR SMD	1/16W 75R J	R543	VE-30014420	RESISTOR SMD	1/16W 10K F
R299	VE-30013001	RESISTOR SMD	1/16W 1K F	R544	VE-30014420	RESISTOR SMD	1/16W 10K F

△Ref No.	Part No.	Part Name	Description Local	△Ref No.	Part No.	Part Name	Description Local
R545	VE-30012677	RESISTOR SMD	1/16W 3.3K J	R760	VE-30014128	RESISTOR SMD	1/16W 33R J
R546	VE-30012677	RESISTOR SMD	1/16W 3.3K J	R761	VE-30014128	RESISTOR SMD	1/16W 33R J
R547	VE-30012677	RESISTOR SMD	1/16W 3.3K J	R762	VE-30014128	RESISTOR SMD	1/16W 33R J
R548	VE-30012692	RESISTOR SMD	1/16W 4.7K J	R763	VE-30012671	RESISTOR SMD	1/16W 24K J
R549	VE-30012692	RESISTOR SMD	1/16W 4.7K J	R908	VE-30014420	RESISTOR SMD	1/16W 10K F
R550	VE-30012692	RESISTOR SMD	1/16W 4.7K J	R909	VE-30014420	RESISTOR SMD	1/16W 10K F
R551	VE-30012692	RESISTOR SMD	1/16W 4.7K J	L100	VE-30001996	FIXED COIL	22uH Q40 K
R552	VE-30012641	RESISTOR SMD	1/16W 10K J	L100	VE-30002002	FIXED COIL	47uH Q60 K
R553	VE-30012641	RESISTOR SMD	1/16W 10K J	L101	VE-30001971	FERRITE SMD	600R/100MHz 200mA
R554	VE-30012510	RESISTOR SMD	1/16W 100R J	L101	VE-30001996	FIXED COIL	22uH Q40 K
R555	VE-30012510	RESISTOR SMD	1/16W 100R J	L101	VE-30001996	FIXED COIL	22uH Q40 K
R556	VE-30012677	RESISTOR SMD	1/16W 3.3K J	L101	VE-30001996	FIXED COIL	22uH Q40 K
R557	VE-30012677	RESISTOR SMD	1/16W 3.3K J	L102	VE-30001971	FERRITE SMD	600R/100MHz 200mA
R558	VE-30012677	RESISTOR SMD	1/16W 3.3K J	L102	VE-30001979	FIXED COIL	1uH Q45 M-A
R600	VE-30012683	RESISTOR SMD	1/16W 330K J	L102	VE-30002170	FERRITE CORE	1A RAD (FTZ)
R601	VE-30012683	RESISTOR SMD	1/16W 330K J	L103	VE-30001979	FIXED COIL	1uH Q45 M-A
R602	VE-30012663	RESISTOR SMD	1/16W 200K J	L103	VE-30001979	FIXED COIL	1uH Q45 M-A
R603	VE-30012700	RESISTOR SMD	1/16W 51K J	L103	VE-30011450	FIXED COIL	22uH 5.4A
R604	VE-30012641	RESISTOR SMD	1/16W 10K J	L104	VE-30018093	FIXED COIL SMD	3.3uH J Q30 185mA
R605	VE-30012641	RESISTOR SMD	1/16W 10K J	L105	VE-30002170	FERRITE CORE	1A RAD (FTZ)
R606	VE-30012641	RESISTOR SMD	1/16W 10K J	L105	VE-30007771	FIXED COIL	100UH
R607	VE-30012665	RESISTOR SMD	1/16W 20K J	L106	VE-30001996	FIXED COIL	22uH Q40 K
R608	VE-30012641	RESISTOR SMD	1/16W 10K J	L106	VE-30011450	FIXED COIL	22uH 5.4A
R609	VE-30013001	RESISTOR SMD	1/16W 1K F	L107	VE-30001971	FERRITE SMD	600R/100MHz 200mA
R610	VE-30012641	RESISTOR SMD	1/16W 10K J	L108	VE-30001971	FERRITE SMD	600R/100MHz 200mA
R611	VE-30012692	RESISTOR SMD	1/16W 4.7K J	L109	VE-30001996	FIXED COIL	22uH Q40 K
R612	VE-30012692	RESISTOR SMD	1/16W 4.7K J	L110	VE-30001971	FERRITE SMD	600R/100MHz 200mA
R613	VE-30000526	RESISTOR CF	1/4W 1.5K J	L111	VE-30001979	FIXED COIL	1uH Q45 M-A
R614	VE-30000622	RESISTOR CF	1/4W 270R J	L112	VE-30018093	FIXED COIL SMD	3.3uH J Q30 185mA
R615	VE-30000633	RESISTOR CF	1/4W 27K J	L113	VE-30006712	FERRITE BEAD	3.5X4.7X0.8
R616	VE-30000504	RESISTOR CF	1/4W 120K J	L114	VE-30001971	FERRITE SMD	600R/100MHz 200mA
R617	VE-30012659	RESISTOR SMD	1/16W 2.2K J	L115	VE-30001971	FERRITE SMD	600R/100MHz 200mA
R620	VE-30012509	RESISTOR SMD	1/16W 100K J	L116	VE-30001971	FERRITE SMD	600R/100MHz 200mA
R651	VE-30012510	RESISTOR SMD	1/16W 100R J	L117	VE-30001971	FERRITE SMD	600R/100MHz 200mA
R652	VE-30012510	RESISTOR SMD	1/16W 100R J	L118	VE-30001971	FERRITE SMD	600R/100MHz 200mA
R653	VE-30017653	RESISTOR SARRAY	1/16W 47RX4 J	L119	VE-30001971	FERRITE SMD	600R/100MHz 200mA
R655	VE-30017653	RESISTOR SARRAY	1/16W 47RX4 J	L120	VE-30001971	FERRITE SMD	600R/100MHz 200mA
R656	VE-30014078	RESISTOR SMD	1/16W 22R J	L121	VE-30001971	FERRITE SMD	600R/100MHz 200mA
R658	VE-30017653	RESISTOR SARRAY	1/16W 47RX4 J	L122	VE-30001994	FIXED COIL	22uH J AXIAL
R659	VE-30014078	RESISTOR SMD	1/16W 22R J	L123	VE-30001996	FIXED COIL	22uH Q40 K
R661	VE-30017653	RESISTOR SARRAY	1/16W 47RX4 J	L124	VE-30001971	FERRITE SMD	600R/100MHz 200mA
R662	VE-30014078	RESISTOR SMD	1/16W 22R J	L125	VE-30001971	FERRITE SMD	600R/100MHz 200mA
R663	VE-30017653	RESISTOR SARRAY	1/16W 47RX4 J	L126	VE-30001994	FIXED COIL	22uH J AXIAL
R664	VE-30014078	RESISTOR SMD	1/16W 22R J	L127	VE-30001996	FIXED COIL	22uH Q40 K
R665	VE-30014078	RESISTOR SMD	1/16W 22R J	L265	VE-30001971	FERRITE SMD	600R/100MHz 200mA
R666	VE-30012987	RESISTOR SMD	1/16W 56R J	L266	VE-30001971	FERRITE SMD	600R/100MHz 200mA
R667	VE-30012987	RESISTOR SMD	1/16W 56R J	L267	VE-30001971	FERRITE SMD	600R/100MHz 200mA
R700	VE-30017653	RESISTOR SARRAY	1/16W 47RX4 J	L268	VE-30001971	FERRITE SMD	600R/100MHz 200mA
R701	VE-30017653	RESISTOR SARRAY	1/16W 47RX4 J	L269	VE-30001971	FERRITE SMD	600R/100MHz 200mA
R702	VE-30017653	RESISTOR SARRAY	1/16W 47RX4 J	L270	VE-30001968	FERRITE SMD	200R/100MHz 200mA
R703	VE-30017653	RESISTOR SARRAY	1/16W 47RX4 J	L271	VE-30001971	FERRITE SMD	600R/100MHz 200mA
R704	VE-30017653	RESISTOR SARRAY	1/16W 47RX4 J	L272	VE-30001968	FERRITE SMD	200R/100MHz 200mA
R705	VE-30017653	RESISTOR SARRAY	1/16W 47RX4 J	L273	VE-30001971	FERRITE SMD	600R/100MHz 200mA
R706	VE-30014022	RESISTOR SMD	1/16W 47R J	L274	VE-30001968	FERRITE SMD	200R/100MHz 200mA
R707	VE-30014022	RESISTOR SMD	1/16W 47R J	L275	VE-30001971	FERRITE SMD	600R/100MHz 200mA
R708	VE-30014022	RESISTOR SMD	1/16W 47R J	L276	VE-30001971	FERRITE SMD	600R/100MHz 200mA
R709	VE-30012692	RESISTOR SMD	1/16W 4.7K J	L277	VE-30001971	FERRITE SMD	600R/100MHz 200mA
R710	VE-30014420	RESISTOR SMD	1/16W 10K F	L280	VE-30001971	FERRITE SMD	600R/100MHz 200mA
R711	VE-30014420	RESISTOR SMD	1/16W 10K F	L281	VE-30001971	FERRITE SMD	600R/100MHz 200mA
R712	VE-30014420	RESISTOR SMD	1/16W 10K F	L282	VE-30001971	FERRITE SMD	600R/100MHz 200mA
R713	VE-30014420	RESISTOR SMD	1/16W 10K F	L283	VE-30001971	FERRITE SMD	600R/100MHz 200mA
R714	VE-30014420	RESISTOR SMD	1/16W 10K F	L284	VE-30001971	FERRITE SMD	600R/100MHz 200mA
R715	VE-30012660	RESISTOR SMD	1/16W 2.2M J	L325	VE-30017542	FIXED COIL SMD	10uH J Q25 155mA
R716	VE-30012673	RESISTOR SMD	1/16W 270R J	L326	VE-30002170	FERRITE CORE	1A RAD (FTZ)
R717	VE-30017653	RESISTOR SARRAY	1/16W 47RX4 J	L375	VE-30001992	FIXED COIL	10uH Q65 K-A
R718	VE-30012684	RESISTOR SMD	1/16W 330R J	L450	VE-30001971	FERRITE SMD	600R/100MHz 200mA
R742	VE-30012642	RESISTOR SMD	1/16W 120K J	L500	VE-30006712	FERRITE BEAD	3.5X4.7X0.8
R743	VE-30012642	RESISTOR SMD	1/16W 120K J	L501	VE-30006712	FERRITE BEAD	3.5X4.7X0.8
R744	VE-30012696	RESISTOR SMD	1/16W 47K J	L600	VE-30006712	FERRITE BEAD	3.5X4.7X0.8
R745	VE-30012708	RESISTOR SMD	1/16W 68K J	L601	VE-30006712	FERRITE BEAD	3.5X4.7X0.8
R746	VE-30012685	RESISTOR SMD	1/16W 33K J	L602	VE-30006712	FERRITE BEAD	3.5X4.7X0.8
R747	VE-30012641	RESISTOR SMD	1/16W 10K J	L603	VE-30006712	FERRITE BEAD	3.5X4.7X0.8
R748	VE-30012641	RESISTOR SMD	1/16W 10K J	L604	VE-30006712	FERRITE BEAD	3.5X4.7X0.8
R749	VE-30012509	RESISTOR SMD	1/16W 100K J	L605	VE-30006712	FERRITE BEAD	3.5X4.7X0.8
R750	VE-30012510	RESISTOR SMD	1/16W 100R J	L606	VE-30001971	FERRITE SMD	600R/100MHz 200mA
R750	VE-30012644	RESISTOR SMD	1/16W 12K J	L607	VE-30006712	FERRITE BEAD	3.5X4.7X0.8
R751	VE-30012510	RESISTOR SMD	1/16W 100R J	L608	VE-30006712	FERRITE BEAD	3.5X4.7X0.8
R751	VE-30012641	RESISTOR SMD	1/16W 10K J	L609	VE-30011450	FIXED COIL	22uH 5.4A
R752	VE-30012696	RESISTOR SMD	1/16W 47K J	L610	VE-30006712	FERRITE BEAD	3.5X4.7X0.8
R753	VE-30012644	RESISTOR SMD	1/16W 12K J	L650	VE-30017542	FIXED COIL SMD	10uH J Q25 155mA
R753	VE-30012696	RESISTOR SMD	1/16W 47K J	L651	VE-30002170	FERRITE CORE	1A RAD (FTZ)
R754	VE-30012696	RESISTOR SMD	1/16W 47K J	L700	VE-30002170	FERRITE CORE	1A RAD (FTZ)
R755	VE-30012510	RESISTOR SMD	1/16W 100R J	L701	VE-30001971	FERRITE SMD	600R/100MHz 200mA
R756	VE-30012657	RESISTOR SMD	1/16W 1K J	L702	VE-30001971	FERRITE SMD	600R/100MHz 200mA
R757	VE-30014420	RESISTOR SMD	1/16W 10K F	L703	VE-30001971	FERRITE SMD	600R/100MHz 200mA
R758	VE-30014420	RESISTOR SMD	1/16W 10K F	L704	VE-30001971	FERRITE SMD	600R/100MHz 200mA
R759	VE-30014022	RESISTOR SMD	1/16W 47R J	L718	VE-30024779	FERRITE SMD	50R/100MHz 3A

△Ref No.	Part No.	Part Name	Description Local
L719	VE-30024779	FERRITE SMD	50R/100MHz 3A
L721	VE-30024779	FERRITE SMD	50R/100MHz 3A
L722	VE-30024779	FERRITE SMD	50R/100MHz 3A
L723	VE-30001999	FIXED COIL	40uH 4A RAD 8*10
L724	VE-30001999	FIXED COIL	40uH 4A RAD 8*10
L725	VE-30001999	FIXED COIL	40uH 4A RAD 8*10
L726	VE-30001999	FIXED COIL	40uH 4A RAD 8*10
L727	VE-30017624	DIODE	SCHOTTKY SB560 5A/60V DO-201AD
L729	VE-30011450	FIXED COIL	22uH 5.4A
L750	VE-30001996	FIXED COIL	22uH Q40 K
F100	VE-20000849	FUSE	3.15A
JK100	VE-30001902	HEADPHONE JACK	STEREO WO/SW
JK101	VE-30001893	RCA JACK	1P YELLOW 28 FAV
JK102	VE-30001891	RCA JACK	1P WHITE 28 FAV
JK103	VE-30001892	RCA JACK	1P RED 28 FAV
JK104	VE-30001895	JACK	4P DIN TYPE FOR SVHS
JK265	VE-30001902	HEADPHONE JACK	STEREO WO/SW
JK266	VE-30001891	RCA JACK	1P WHITE 28 FAV
JK267	VE-30001892	RCA JACK	1P RED 28 FAV
SW1	VE-30002181	TACT SWITCH	
SW2	VE-30002181	TACT SWITCH	
SW3	VE-30002181	TACT SWITCH	
SW4	VE-30002181	TACT SWITCH	
SW7	VE-30002181	TACT SWITCH	
SW8	VE-30002181	TACT SWITCH	
SW9	VE-30002181	TACT SWITCH	
△TU100	VE-30020655	TUNER WSP (PLL)	38.9 TMK3-HORIZONTAL-PIP
△TU101	VE-30020654	TUNER WSP (PLL)	38.9 MK3 - HORIZONTAL
X100	VE-30002851	CLYSTAL	4.000 30p HC49U
X101	VE-30002851	CLYSTAL	4.000 30p HC49U
X102	VE-30001756	CLYSTAL	18.432 12p HC49U
X325	VE-30001741	CLYSTAL	24.576 20p HC49U
X500	VE-30017946	CLYSTAL	14.318 MHZ
X650	VE-30001741	CLYSTAL	24.576 20p HC49U
X700	VE-30001736	CLYSTAL	10.000 30p HC49U
X750	VE-30001737	CLYSTAL	12.000 20p HC49U
Z100	VE-30001692	SAW FILTER	OFWK3953M
Z101	VE-30012545	SAW FILTER	K9656M
Z102	VE-30001692	SAW FILTER	OFWK3953M
Z103	VE-30012545	SAW FILTER	K9656M

PACKING

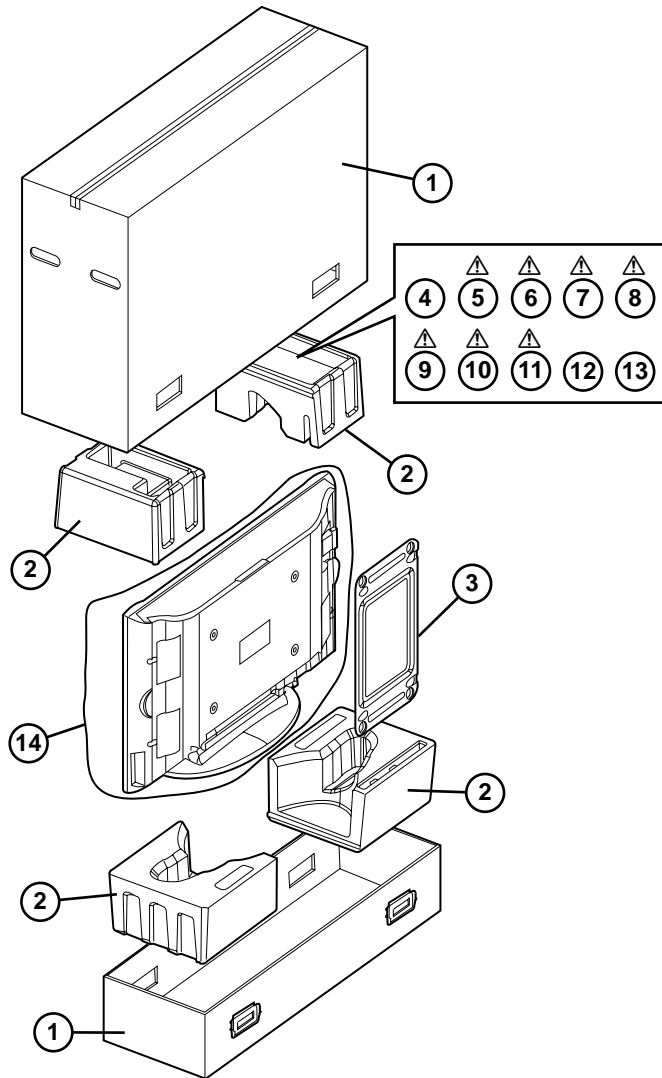

PACKING PARTS LIST

△ Ref.No.	Part No.	Part Name	Description	Local
1	VE-20186614	CARTON BOX	TOP, BOTTOM 1SET	LT-30E45SJ
1	VE-20185767	CARTON BOX	TOP, BOTTOM 1SET	LT-30E45SU,LT-30E45SU/Z
1	VE-20186619	CARTON BOX	TOP, BOTTOM 1SET	LT-30E45SU/N
2	VE-20152218	SNOW BOX ASSY	4pcs in 1set	
3	VE-35009248	SUPPORT BRACKET		LT-30E45SU/N
4	VE-30034032	REMOTE CONTROL UNIT	RM-C1860	
△ 5	VE-50060086	INST BOOK	Bulgarian/Russian/Romanian	LT-30E45SU,LT-30E45SU/Z
△ 6	VE-50060084	INST BOOK	Portuguese/Dutch/Spanish	LT-30E45SU,LT-30E45SU/Z
△ 7	VE-50059497	INST BOOK	Polish/Czech/Hungarian	LT-30E45SU,LT-30E45SU/N,LT-30E45SU/Z
△ 8	VE-50059496	INST BOOK	Danish/Finn/Norwegian/Swedish	LT-30E45SU,LT-30E45SU/N,LT-30E45SU/Z
△ 9	VE-50059494	INST BOOK	English/German/French/Italian	LT-30E45SU,LT-30E45SU/N,LT-30E45SU/Z
△ 10	VE-50059704	INST BOOK	English	LT-30E45SJ
△ 11	VE-30028238	POWER CORD		LT-30E45SU
△ 11	VE-30024540	POWER CORD		LT-30E45SU,LT-30E45SU/N
△ 11	VE-30035135	POWER CORD		LT-30E45SU/Z
12	-----	WARANTY CARD	BT-54023-1E	
13	-----	BATTERY	AA/R06(x2)	
14	VE-50038565	POLY BAG		