

SERVICE MANUAL

COLOR TELEVISION

- This Service Manual is the "Revision Publishing" and replaces "Simple Manual" (S/M Code No. 09-005-431-9T1).
- This Service Manual does not include "ADJUSTMENT". This item will be issued in the next Supplement.

aiwa
S/M Code No. 09-007-431-9R1

REVISION
DATA

ELETRICAL MAIN PARTS LIST

REF. NO.	PART NO.	KANRI NO.	DESCRIPTION	REF. NO.	PART NO.	KANRI NO.	DESCRIPTION
IC				MAIN C.B			
	8A-JE7-621-010		IC,M37272MA-052SP	C001	87-010-405-080		CAP,E 10-50 M 11L SME
	87-A91-538-010		RCR UNIT,SBX1981-72P	C002	87-018-209-080		CAP,TC U 0.1-50 Z F UP050
	87-A21-378-010		IC,S-24C04BDP-1A	C003	87-018-134-080		CAP,TC U 0.01-16 N Y UP050
	87-A20-611-080		IC,M51943BSL-700A	C004	87-018-127-080		CAP,TC U 470P-50 K B UP050
	87-001-536-010		IC,NJM78M05FA	C005	87-010-401-080		CAP,E 1-50 M 11L SME
	8Z-JBJ-605-010		IC,TA1268N	C006	87-018-209-080		CAP,TC U 0.1-50 Z F UP050
	87-A21-103-040		C-IC,MM1454XFBE	C007	87-010-248-080		CAP,E 220-10 M 11L SME
	87-A21-022-040		C-IC,BA3880FS	C008	87-018-123-080		CAP,TC U 220P-50 K B UP050
	87-A21-554-010		IC,TA1216AN	C009	87-010-401-080		CAP,E 1-50 M 11L SME
	87-A21-283-010		IC,AN5277	C010	87-018-131-080		CAP,TC U 1000P-50 K B UP050
	87-A21-220-010		IC,MM1311AD	C011	87-018-134-080		CAP,TC U 0.01-16 N Y UP050
	87-A21-219-010		IC,TC90A45P	C012	87-018-119-080		CAP,TC U 100P-50 K B UP050
	87-A21-456-010		IC,LA7833	C013	87-018-119-080		CAP,TC U 100P-50 K B UP050
	87-070-417-010		IC,NJM4558DD	C014	87-010-263-080		CAP,E 100-10 M 11L SME
	8Z-JBH-605-010		IC,CXA2104S	C015	87-018-119-080		CAP,TC U 100P-50 K B UP050
	87-A21-468-010		IC,STR-F6626	C016	87-018-131-080		CAP,TC U 1000P-50 K B UP050
	87-A21-491-010		IC,SE125N	C017	87-018-128-080		CAP,TC U 560P-50 K B UP050
	87-020-969-010		IC,NJM78M09FA	C018	87-018-109-080		CAP,TC U 22P-50 J SL UP050
	87-A20-389-010		IC,NJM7809FA	C019	87-018-109-080		CAP,TC U 22P-50 J SL UP050
				C020	87-018-119-080		CAP,TC U 100P-50 K B UP050
TRANSISTOR				C021	87-018-109-080		CAP,TC U 22P-50 J SL UP050
	87-A30-065-080		TR,2SC2785FE	C022	87-018-109-080		CAP,TC U 22P-50 J SL UP050
	87-026-269-080		TR,DTA114ES	C023	87-018-123-080		CAP,TC U 220P-50 K B UP050
	87-A30-066-080		TR,2SA1175FE	C024	87-018-209-080		CAP,TC U 0.1-50 Z F UP050
	87-026-219-080		TR,DTA144ES	C025	87-018-119-080		CAP,TC U 100P-50 K B UP050
	87-026-218-080		TR,DTC144ES	C101	87-010-404-080		CAP,E 4.7-50 M 11L SME
	89-324-122-080		C-TR,2SC2412KR	C104	87-010-248-080		CAP,E 220-10 M 11L SME
	89-110-372-080		C-TR,2SA1037K(R)	C105	87-018-134-080		CAP,TC U 0.01-16 N Y UP050
	87-A30-062-080		C-TR,KRC104S	C106	87-A10-207-080		CAP,TC U 0.01-50 K B UP050
	89-324-820-080		TR,2SC2482	C112	87-018-109-080		CAP,TC U 22P-50 J SL UP050
	87-A30-366-010		TR,2SD2580	C113	87-018-109-080		CAP,TC U 22P-50 J SL UP050
	87-A30-363-010		TR,2SD2531	C201	87-018-134-080		CAP,TC U 0.01-16 N Y UP050
	89-110-154-080		TR,2SA1015Y	C202	87-018-134-080		CAP,TC U 0.01-16 N Y UP050
	89-318-155-080		TR,2SC1815GR	C203	87-010-400-080		CAP,E 0.47-50 M 11L SME
	87-026-463-080		TR,2SA933SRS	C204	87-018-134-080		CAP,TC U 0.01-16 N Y UP050
	89-110-913-080		TR,2SA10910	C205	87-010-237-080		CAP,E 1000-16 M SME
	87-A30-344-010		TR,2SC5147D	C206	87-A10-287-080		CAP,M 2200P-50 J
	87-026-462-080		TR,2SC1740SRS	C207	87-010-400-080		CAP,E 0.47-50 M 11L SME
	89-407-742-080		TR,2SD774	C208	87-018-134-080		CAP,TC U 0.01-16 N Y UP050
	89-118-370-010		TR,2SA1837	C209	87-010-385-080		CAP,E 220-25 M SME
	89-347-930-010		TR,2SC4793	C210	87-A11-080-080		CAP,TC U 47P-50 J CH
				C211	87-A11-080-080		CAP,TC U 47P-50 J CH
				C212	87-A11-080-080		CAP,TC U 47P-50 J CH
				C213	87-A11-082-080		CAP,TC U 56P-50 J CH
				C214	87-018-134-080		CAP,TC U 0.01-16 N Y UP050
DIODE				C229	87-018-149-080		CAP,TC U 15P-50 J CH UP050
	87-070-110-010		LED,SLP-181B-51 RED	C301	87-010-403-080		CAP,E 3.3-50 M 11L SME
	87-017-932-080		ZENER,MTZJ6.2B	C302	87-018-134-080		CAP,TC U 0.01-16 N Y UP050
	87-020-465-080		DIODE,1SS133	C305	87-018-126-080		CAP,TC U 390P-50 K B UP050
	87-002-743-080		ZENER,MTZJ33B	C306	87-010-405-080		CAP,E 10-50 M 11L SME
	87-A40-235-080		ZENER,MTZJ9.1C	C307	87-A10-299-080		CAP,M 0.022-50 J
	87-A40-690-080		ZENER,MTZJ11B	C308	87-010-401-080		CAP,E 1-50 M 11L SME
	87-A40-286-080		DIODE, RGP10JE-5025	C309	87-018-147-080		CAP,TC U 10P-50 J CH UP050
	87-A40-348-080		ZENER,MTZJ3.3A	C311	87-018-209-080		CAP,TC U 0.1-50 Z F UP050
	87-A40-234-080		ZENER,MTZJ5.6A	C312	87-018-209-080		CAP,TC U 0.1-50 Z F UP050
	87-A40-318-080		ZENER,RM26 V1	C313	87-018-209-080		CAP,TC U 0.1-50 Z F UP050
	87-070-092-080		DIODE,S5566B	C314	87-018-134-080		CAP,TC U 0.01-16 N Y UP050
	87-A40-735-090		DIODE,ERC06-15	C315	87-018-123-080		CAP,TC U 220P-50 K B UP050
	87-A40-001-080		ZENER,MTZJ12C	C317	87-010-402-080		CAP,E 2.2-50 M 11L SME
	87-017-593-090		DIODE, RGP15J	C318	87-018-134-080		CAP,TC U 0.01-16 N Y UP050
	87-017-654-060		DIODE, GBU6JL6131	C319	87-010-237-080		CAP,E 1000-16 M SME
	87-A40-856-080		DIODE,UF4007	C321	87-010-404-080		CAP,E 4.7-50 M 11L SME
	87-A40-828-080		DIODE,AK 04	C322	87-A10-295-080		CAP,M 0.01-50 J
	87-A40-825-090		DIODE,RN 1Z	C323	87-016-280-080		CAP,E 3.3-50 M BP SME
	87-A40-734-010		DIODE,FML-G12S	C324	87-018-134-080		CAP,TC U 0.01-16 N Y UP050
	87-A40-354-090		DIODE,UF3GL-6251	C325	87-018-134-080		CAP,TC U 0.01-16 N Y UP050
	8Z-JBH-606-010		VRIS,TNR15G271K	C326	87-A10-307-080		CAP,M 0.1-50 J
	87-A40-553-080		DIODE,1N4003 LES	C327	87-018-134-080		CAP,TC U 0.01-16 N Y UP050
	87-017-650-080		DIODE,1SS119				
	87-A40-503-080		ZENER,MTZJ39B				

REF. NO.	PART NO.	KANRI NO.	DESCRIPTION	REF. NO.	PART NO.	KANRI NO.	DESCRIPTION
C328	87-010-405-080		CAP,E 10-50 M 11L SME	C807	87-A10-568-010		CAP,PP 1000P-630 J APH
C329	87-018-134-080		CAP,TC U 0.01-16 N Y UP050	C808	87-010-384-080		CAP,E 100-25 M 11L SME
C330	87-010-401-080		CAP,E 1-50 M 11L SME	C809	87-018-131-080		CAP,TC U 1000P-50 K B UP050
C331	87-010-544-080		CAP,E 0.1-50 M 11L SME	C810	87-018-129-080		CAP,TC U 680P-50 K B UP050
C332	87-018-134-080		CAP,TC U 0.01-16 N Y UP050	C811	87-018-131-080		CAP,TC U 1000P-50 K B UP050
C333	87-018-134-080		CAP,TC U 0.01-16 N Y UP050	C813	87-018-131-080		CAP,TC U 1000P-50 K B UP050
C334	87-018-209-080		CAP,TC U 0.1-50 Z F UP050	C814	87-010-260-080		CAP,E 47-25 M 11L SME
C335	87-015-997-010		CAP,E 2200-16 M SME	C815	87-010-260-080		CAP,E 47-25 M 11L SME
C336	87-018-134-080		CAP,TC U 0.01-16 N Y UP050	C816	87-010-405-080		CAP,E 10-50 M 11L SME
C337	87-018-130-080		CAP,TC U 820P-50 K B UP050	C817	87-010-398-090		CAP,E 2200-35 M SME
C338	87-010-405-080		CAP,E 10-50 M 11L SME	C818	87-018-209-080		CAP,TC U 0.1-50 Z F UP050
C339	87-018-134-080		CAP,TC U 0.01-16 N Y UP050	C820	87-010-405-080		CAP,E 10-50 M 11L SME
C340	87-018-118-080		CAP,TC U 82P-50 J B UP050	C821	87-010-405-080		CAP,E 10-50 M 11L SME
C341	87-018-118-080		CAP,TC U 82P-50 J B UP050	C822	87-018-209-080		CAP,TC U 0.1-50 Z F UP050
C342	87-018-150-080		CAP,TC U 18P-50 J CH UP050	C824	87-010-237-080		CAP,E 1000-16 M SME
C343	87-A10-307-080		CAP,M 0.1-50 J	C826	87-010-976-080		CAP,CER 1000P-500 K B DD10
C344	87-A10-307-080		CAP,M 0.1-50 J	C829	87-010-384-080		CAP,E 100-25 M 11L SME
C501	87-010-405-080		CAP,E 10-50 M 11L SME	C831	87-010-405-080		CAP,E 10-50 M 11L SME
C504	87-010-393-080		CAP,E 100-35 M SME	C834	87-A10-733-090		CAP,E 220-160 M SK
C505	87-018-131-080		CAP,TC U 1000P-50 K B UP050	C835	87-A10-833-010		CAP,CER 1000P-2K K R LONG
C508	87-010-398-090		CAP,E 2200-35 M SME	C838	87-010-397-010		CAP,E 1000-35 M SME
C509	87-A11-245-080		CAP,M/P 0.1-100 J TF-ECQV	C842	87-012-370-010		CAP,CER 3300P-250 M E ECKD
C510	87-010-405-080		CAP,E 10-50 M 11L SME	C843	87-012-370-010		CAP,CER 3300P-250 M E ECKD
C605	87-A10-972-090		CAP,M/P 0.015-1.25K H DKRG	C844	87-012-370-010		CAP,CER 3300P-250 M E ECKD
C607	87-A12-351-090		CAP,M/P 0.013-800 H DKRG	C845	87-012-370-010		CAP,CER 3300P-250 M E ECKD
C608	87-A10-833-010		CAP,CER 1000P-2K K R LONG	C846	87-A10-207-080		CAP,TC U 0.01-50 K B UP050
C609	87-A10-975-090		CAP,M/P 0.68-250 J	CF201	84-LB3-626-080		FLTR,TPS4.5MB2
C610	87-A10-833-010		CAP,CER 1000P-2K K R LONG	CF202	84-LB3-627-080		FLTR,SFSH 4.5MDB SIF
C611	87-010-963-080		CAP,E 2.2-160 M 11L SME	CN001	87-009-195-010		CONN,5P V WHT EH
C612	87-010-976-080		CAP,CER 1000P-500 K B DD10	CN601	87-099-762-010		CONN,5P V TBL-P BOSS
C613	87-016-373-080		CAP,E 10-250 M SME	CN701	87-A60-628-010		CONN,11P V 2MM JMT
C614	87-010-976-080		CAP,CER 1000P-500 K B DD10	CN705	87-009-262-010		CONN,8P V 52147
C615	87-A10-843-080		CAP,CER 680P-1K K R	CN706	87-099-186-010		CONN,6P V WHT EH
C616	87-A10-843-080		CAP,CER 680P-1K K R	CN707	87-A61-126-080		MALE, 1P TP42097
C617	87-A12-082-090		CAP,E 1000-35 SMG	CN807	82-481-649-010		CONN,2P V VT-50P
C618	87-A10-301-080		CAP,M 0.033-50 J	CNA101	8Z-JE5-637-010		CONN ASSY,1P PS-MAIN
C619	87-A11-987-080		CAP,CER 6800P-250 K R HR	CNA103	8A-JE5-627-010		CONN ASSY,2P MAIN-S
C620	87-010-395-080		CAP,E 330-35 M SME	CNA602	8Z-JE5-632-010		CONN ASSY,5P V WHT TV-NK-1
C621	87-018-131-080		CAP,TC U 1000P-50 K B UP050	CNA604	8Z-JE5-638-010		CONN ASSY,1P FBT-PS
C622	87-A11-124-080		CAP,TC U 2200P-50 K B	CNA704	8A-JE5-617-010		CONN ASSY,6P V WHT TV-NK-2
C623	87-A12-171-080		CAP,E 4.7-50 K SH	CNA801	8A-JE5-619-010		CONN ASSY,3P V MAIN-PS
C624	87-010-975-080		CAP,CER 330P-500 K B DD10	CNA803	8Z-JE5-636-010		CONN ASSY,2P PS-MAIN 5V
C626	87-010-405-080		CAP,E 10-50 M 11L SME	FB001	87-008-372-080		FLTR,EMI BL01 RN1
C627	87-010-975-080		CAP,CER 330P-500 K B DD10	FB002	87-008-372-080		FLTR,EMI BL01 RN1
C629	87-A10-469-080		CAP,CER 2200P-500 K B DD10	FB003	87-008-372-080		FLTR,EMI BL01 RN1
C630	87-010-405-080		CAP,E 10-50 M 11L SME	FB004	87-008-372-080		FLTR,EMI BL01 RN1
C631	87-010-263-080		CAP,E 100-10 M 11L SME	FB005	87-008-372-080		FLTR,EMI BL01 RN1
C655	87-A11-354-090		CAP,E 100-160 M SMG	FB006	87-008-372-080		FLTR,EMI BL01 RN1
C714	87-010-221-080		CAP,E 470-10 M SME	FB007	87-008-372-080		FLTR,EMI BL01 RN1
C720	87-015-464-080		CAP,E 4.7-16 BP	FB301	87-003-320-080		F-BEAD,-9.0 FBR07HA121NB-00
C721	87-A10-292-080		CAP,M 5600P-50 J	FB601	87-003-223-080		F-BEAD, BL02RN2
C722	87-A10-296-080		CAP,M 0.012-50 J	FB602	87-003-223-080		F-BEAD, BL02RN2
C723	87-010-401-080		CAP,E 1-50 M 11L SME	FB801	87-003-320-080		F-BEAD,-9.0 FBR07HA121NB-00
C724	87-010-404-080		CAP,E 4.7-50 M 11L SME	FB802	87-003-320-080		F-BEAD,-9.0 FBR07HA121NB-00
C725	87-010-405-080		CAP,E 10-50 M 11L SME	FB803	87-003-320-080		F-BEAD,-9.0 FBR07HA121NB-00
C726	87-010-404-080		CAP,E 4.7-50 M 11L SME	FB804	87-003-320-080		F-BEAD,-9.0 FBR07HA121NB-00
C727	87-010-112-080		CAP,E 100-16 M 11L SME	FB805	87-003-320-080		F-BEAD,-9.0 FBR07HA121NB-00
C728	87-015-464-080		CAP,E 4.7-16 BP	FB806	87-003-320-080		F-BEAD,-9.0 FBR07HA121NB-00
C729	87-010-404-080		CAP,E 4.7-50 M 11L SME	FB807	87-003-320-080		F-BEAD,-9.0 FBR07HA121NB-00
C730	87-015-464-080		CAP,E 4.7-16 BP	FR601	87-029-158-060		RES,FUSE 1-1W J
C731	87-A10-288-080		CAP,M 2700P-50 J	FR608	87-A00-628-090		RES,FUSE 0.68-1W J RF 1SL12.5
C733	87-016-301-080		CAP,TN 3.3-16 K DN	FR610	87-A00-628-090		RES,FUSE 0.68-1W J RF 1SL12.5
C734	87-015-464-080		CAP,E 4.7-16 BP	FR801	87-A00-770-090		RES,FUSE 0.1-1W J RF1SL12.5
C735	87-016-302-080		CAP,TN 10-16 K DN	HL001	84-LB3-216-010		HLDR,LED
C736	87-010-401-080		CAP,E 1-50 M 11L SME	J702	87-A60-324-110		JACK,PIN 6P Y-W-R W/SW
C737	87-018-134-080		CAP,TC U 0.01-16 N Y UP050	L002	87-005-614-080		COIL,100UH J LAV35
C802	87-018-131-080		CAP,TC U 1000P-50 K B UP050	L003	87-005-614-080		COIL,100UH J LAV35
C804	87-A11-308-090		CAP,M/P 0.033-630 J ECQF6(ZH)	L101	87-005-614-080		COIL,100UH J LAV35
C805	87-A10-846-080		CAP,CER 3300P-1K K R	L201	8Z-JBR-612-010		COIL,SIF 4.5MHZ 504BN
C806	87-A12-298-090		CAP,E 820-200 M 25B SMH	L203	87-005-612-080		COIL,68UH J LAV35

REF. NO.	PART NO.	KANRI NO.	DESCRIPTION	REF. NO.	PART NO.	KANRI NO.	DESCRIPTION
L204	87-003-282-080		COIL,12UH J LAL02	C408	87-010-405-080		CAP,E 10-50 M 11L SME
L205	8Z-JBH-610-010		COIL,PIF-SQ57EL349A 45.75MHZ	C409	87-010-404-080		CAP,E 4.7-50 M 11L SME
L206	87-005-614-080		COIL,100UH J LAV35	C410	87-010-404-080		CAP,E 4.7-50 M 11L SME
L207	87-003-147-080		COIL,22UH J LAL02	C411	87-010-404-080		CAP,E 4.7-50 M 11L SME
L208	87-003-143-080		COIL,4.7UH K LAL02	C413	87-A10-295-080		CAP,M 0.01-50 J
L301	87-003-097-080		COIL,1.0UH K LAL02	C414	87-A10-305-080		CAP,M 0.068-50 J
L302	87-005-614-080		COIL,100UH J LAV35	C415	87-A10-293-080		CAP,M 6800P-50 J
L303	87-005-614-080		COIL,100UH J LAV35	C416	87-010-260-080		CAP,E 47-25 M 11L SME
L304	87-003-282-080		COIL,12UH J LAL02	C417	87-010-404-080		CAP,E 4.7-50 M 11L SME
L604	87-A50-607-080		COIL,3.9MH J LHL10	C418	87-010-197-080		C-CAP,S 0.01-25 K B C2012
L606	8Z-JE5-621-010		COIL,HLC ZJE-5	C419	87-010-404-080		CAP,E 4.7-50 M 11L SME
L607	87-A50-541-010		COIL,1MH 1.5AP-P	C420	87-010-404-080		CAP,E 4.7-50 M 11L SME
L701	87-005-614-080		COIL,100UH J LAV35	C421	87-010-404-080		CAP,E 4.7-50 M 11L SME
L801	87-A50-170-010		COIL,390UH RCH106	C422	87-A10-293-080		CAP,M 6800P-50 J
L803	87-A50-176-080		COIL,33UH-PJ87	C424	87-010-260-080		CAP,E 47-25 M 11L SME
△ PR601	87-A90-429-080		FUSE,1.25A 125V A 251	C425	87-A10-305-080		CAP,M 0.068-50 J
△ PR801	87-A90-409-080		FUSE,1.5A 125V A 251	C426	87-A10-295-080		CAP,M 0.01-50 J
△ PR802	87-A90-210-080		FUSE,7A 125V 251	C427	87-010-404-080		CAP,E 4.7-50 M 11L SME
△ PR803	87-A90-070-080		FUSE,3.5A 125V 251	C428	87-010-189-080		C-CAP,S 8200P-50 K B
△ PS801	87-A90-717-010		P-COUPPLER,PC123FY2	C429	87-012-365-080		C-CAP,S 0.027-25 K B
△ PT801	8A-JE5-622-010		PT,U SW AJE-5	C430	87-010-401-080		CAP,E 1-50 M 11L SME
R315	87-025-380-080		RES,M/F 15K-1/6W F	C431	87-010-189-080		C-CAP,S 8200P-50 K B
R316	87-025-427-080		RES,M/F 27K-1/6W F	C432	87-010-197-080		C-CAP,S 0.01-25 K B C2012
R506	87-A00-143-090		RES,M/F 1.0-1W J RSF(S)	C433	87-010-260-080		CAP,E 47-25 M 11L SME
R508	87-A00-653-090		RES,M/F 270-1W J RSF(S)	C434	87-012-365-080		C-CAP,S 0.027-25 K B
R604	87-A00-565-090		RES,M/F 1.2K-7W J RSU7	C435	87-010-401-080		CAP,E 1-50 M 11L SME
R612	87-A00-629-090		RES,M/F 5.6-1W J RSF(S)	C436	87-010-401-080		CAP,E 1-50 M 11L SME
R626	87-A00-676-090		RES,M/F 100-7W J RSV7	C437	87-010-401-080		CAP,E 1-50 M 11L SME
R723	87-A00-130-080		RES,M/F 62K-1/6W F	C438	87-010-178-080		C-CAP,S 1000P-50 K B C2012
R801	87-A00-661-010		RES,CEM 27-2W J BGR2U	C439	87-A10-307-080		CAP,M 0.1-50 J
R802	87-A00-160-090		RES,M/F 33-2W J RSF(S)	C440	87-A10-307-080		CAP,M 0.1-50 J
R803	87-A00-356-090		RES,M/F 22-2W J RSS2X	C441	87-A10-307-080		CAP,M 0.1-50 J
R804	87-A00-633-090		RES,CEM 0.47-10W J RGC	C442	87-010-401-080		CAP,E 1-50 M 11L SME
R805	87-A00-170-090		RES,M/F 82K-3W J RSF(S)	C443	87-010-405-080		CAP,E 10-50 M 11L SME
R806	87-A00-380-090		RES,M/F 39K-3W J RSS H2	C444	87-010-405-080		CAP,E 10-50 M 11L SME
R811	87-A00-646-090		RES,CEM 0.1-5W K RGC5	C445	87-010-405-080		CAP,E 10-50 M 11L SME
R824	87-A00-315-090		RES,M/F 1K-1W J RSF(S)	C446	87-010-405-080		CAP,E 10-50 M 11L SME
R833	87-A00-199-090		RES,M/F 12K-3W J RSF(S)	C447	87-010-405-080		CAP,E 10-50 M 11L SME
R834	87-A00-223-090		RES,M/F 47K-2W J RSF(S)	C448	87-010-197-080		C-CAP,S 0.01-25 K B C2012
R844	87-A00-254-090		RES,M/F 0.68-2W J	C449	87-010-402-080		CAP,E 2.2-50 M 11L SME
△ RY801	87-A91-390-010		RELAY,AC12V G5PA-1-8	C450	87-010-247-080		CAP,E 100-50 M SME
S002	87-A91-525-080		SW,TACT SKQNLA	C451	87-010-388-080		CAP,E 1000-25 M SME
S003	87-A91-525-080		SW,TACT SKQNLA	C452	87-010-388-080		CAP,E 1000-25 M SME
S004	87-A91-525-080		SW,TACT SKQNLA	C453	87-010-178-080		C-CAP,S 1000P-50 K B C2012
S005	87-A91-525-080		SW,TACT SKQNLA	C454	87-010-399-090		CAP,E 3300-35 M SME
S006	87-A91-525-080		SW,TACT SKQNLA	C455	87-010-393-080		CAP,E 100-35 M SME
S007	87-A91-525-080		SW,TACT SKQNLA	C460	87-010-197-080		C-CAP,S 0.01-25 K B C2012
S801	87-A91-410-010		SW,AC PUSH 1-1-1 ESB92SH1B	C464	87-010-260-080		CAP,E 47-25 M 11L SME
SFR501	87-024-429-080		SFR,1K H RH063MC	C465	87-010-178-080		C-CAP,S 1000P-50 K B C2012
SFR601	87-024-434-080		SFR,22K H RH063MC	C466	87-A10-295-080		CAP,M 0.01-50 J
SFR602	87-024-429-080		SFR,1K H RH063MC	C467	87-010-401-080		CAP,E 1-50 M 11L SME
SFR603	87-A90-385-080		SFR,22K H DIA6 EVM	C468	87-A10-295-080		CAP,M 0.01-50 J
SWF201	8Z-JBH-633-010		FLTR,SAW M1969M	C469	87-A10-295-080		CAP,M 0.01-50 J
△ T601	8Z-JE5-606-010		FBT,D NX-4523 ZJE-5	C470	87-010-154-080		C-CAP,S 10P-50 D CH GRM
△ T602	85-JT2-653-010		PT,HDT-TV141-2	C471	87-012-155-080		C-CAP,S 180P-50 J CH GRM
△ TH801	87-A91-579-010		POS-THMS,PTH451BG3R0Q140	C472	87-A10-295-080		CAP,M 0.01-50 J
TU101	8Z-JBE-610-010		TU UNIT,USA ENV56D74G3	C473	87-A10-295-080		CAP,M 0.01-50 J
X001	87-A70-124-080		VIB,CER 8.0MHZ	C474	87-A10-295-080		CAP,M 0.01-50 J
X301	87-A70-007-080		VIB,XTAL 3.58MHZ AQC-1001	C475	87-010-178-080		C-CAP,S 1000P-50 K B C2012
X302	87-030-327-010		VIB,CER 503.500KHZ CSB F30	C476	87-010-260-080		CAP,E 47-25 M 11L SME
AUDIO C.B				C477	87-010-316-080		C-CAP,S 33P-50 J CH GRM
C401	87-010-404-080		CAP,E 4.7-50 M 11L SME	C478	87-010-316-080		C-CAP,S 33P-50 J CH GRM
C402	87-A10-295-080		CAP,M 0.01-50 J	C479	87-010-318-080		C-CAP,S 47P-50 J CH GRM
C403	87-A10-295-080		CAP,M 0.01-50 J	C480	87-010-316-080		C-CAP,S 33P-50 J CH GRM
C404	87-A10-307-080		CAP,M 0.1-50 J	C481	87-010-316-080		C-CAP,S 33P-50 J CH GRM
C405	87-010-404-080		CAP,E 4.7-50 M 11L SME	C482	87-010-196-080		C-CAP,S 0.1-25 Z F C2012
C406	87-010-260-080		CAP,E 47-25 M 11L SME	C483	87-010-260-080		CAP,E 47-25 M 11L SME
C407	87-010-197-080		C-CAP,S 0.01-25 K B C2012	C484	87-010-197-080		C-CAP,S 0.01-25 K B C2012
				C486	87-010-197-080		C-CAP,S 0.01-25 K B C2012
				C487	87-010-196-080		C-CAP,S 0.1-25 Z F C2012

REF. NO.	PART NO.	KANRI NO.	DESCRIPTION	REF. NO.	PART NO.	KANRI NO.	DESCRIPTION
C488	87-010-384-080		CAP,E 100-25 M 11L SME	C915	87-010-260-080		CAP,E 47-25 M 11L SME
C489	87-010-197-080		C-CAP,S 0.01-25 K B C2012	C916	87-018-134-080		CAP,TC U 0.01-16 N Y UP050
C492	87-010-197-080		C-CAP,S 0.01-25 K B C2012	C917	87-010-970-090		CAP,CER 4700P-2K K B DE
C493	87-A10-307-080		CAP,M 0.1-50 J	C951	87-010-381-080		CAP,E 330-16 M SME
C494	87-A10-307-080		CAP,M 0.1-50 J	C953	87-018-119-080		CAP,TC U 100P-50 K B UP050
C495	87-010-400-080		CAP,E 0.47-50 M 11L SME	C954	87-010-405-080		CAP,E 10-50 M 11L SME
C496	87-010-400-080		CAP,E 0.47-50 M 11L SME	C955	87-010-405-080		CAP,E 10-50 M 11L SME
C497	87-010-405-080		CAP,E 10-50 M 11L SME	C956	87-010-405-080		CAP,E 10-50 M 11L SME
C751	87-010-545-080		CAP,E 0.22-50 M 11L SME	C957	87-018-122-080		CAP,TC U 180P-50 K B UP050
C752	87-010-402-080		CAP,E 2.2-50 M 11L SME	C958	87-018-119-080		CAP,TC U 100P-50 K B UP050
C753	87-010-545-080		CAP,E 0.22-50 M 11L SME	C959	87-A10-050-010		CAP,CER 4700P-500 K
C754	87-010-402-080		CAP,E 2.2-50 M 11L SME	C960	87-010-221-080		CAP,E 470-10 M SME
C755	87-010-197-080		C-CAP,S 0.01-25 K B C2012	C961	87-A12-168-080		CAP,E 33-160 M SMG
C756	87-010-545-080		CAP,E 0.22-50 M 11L SME	C962	87-A12-010-080		CAP,M/P 0.047-250 J ECQE2
C757	87-010-402-080		CAP,E 2.2-50 M 11L SME	C963	87-A10-283-080		CAP,M 1000P-50 J
C758	87-010-545-080		CAP,E 0.22-50 M 11L SME	C964	87-A10-283-080		CAP,M 1000P-50 J
C759	87-010-402-080		CAP,E 2.2-50 M 11L SME	C965	87-010-963-080		CAP,E 470-10 M SME
C760	87-010-197-080		C-CAP,S 0.01-25 K B C2012	C966	87-A12-014-080		CAP,M/P 0.1-250 J ECQE2
C761	87-010-314-080		C-CAP,S 22P-50 J CH GRM	C967	87-A10-303-080		CAP,M 0.047-50 J
C762	87-010-314-080		C-CAP,S 22P-50 J CH GRM	C968	87-010-221-080		CAP,E 470-10 M SME
C763	87-010-405-080		CAP,E 10-50 M 11L SME	CN901	87-009-034-010		CONN,6P V WHT PH
C764	87-010-401-080		CAP,E 1-50 M 11L SME	CN902	87-009-195-010		CONN,5P V WHT EH
C765	87-010-382-080		CAP,E 22-25 M 11L SME	CN903	87-A61-126-080		MALE, 1P TP42097
C766	87-010-402-080		CAP,E 2.2-50 M 11L SME	CN904	87-A61-060-080		CONN,1P V RED TP00706
C767	87-010-401-080		CAP,E 1-50 M 11L SME	CN951	87-009-030-010		CONN,2P V WHT PH
C768	87-010-402-080		CAP,E 2.2-50 M 11L SME	CN952	8A-JE7-620-010		CONN ASSY,2P VM-NK
C769	87-010-405-080		CAP,E 10-50 M 11L SME	CN952	87-099-043-010		CONN,2P V WHT EH
C770	87-010-405-080		CAP,E 10-50 M 11L SME	L901	87-005-608-080		COIL,33UH J LAV35
C780	87-010-405-080		CAP,E 10-50 M 11L SME	L902	87-005-608-080		COIL,33UH J LAV35
C781	87-010-405-080		CAP,E 10-50 M 11L SME	L903	87-005-608-080		COIL,33UH J LAV35
CN401	87-009-314-010		CONN,8P V 51048	L951	87-005-482-080		COIL,56UH J FLR50
CN404	8Z-JE5-640-010		CONN ASSY,4P SP-25	L952	87-005-481-080		COIL,47UH J FLR50
CN404	87-049-469-010		CONN,4P V WHT EH	R901	87-A00-242-090		RES,M/F 8.2K-3W J RSF(S)
CN405	87-009-317-010		CONN,11P V 51048	R902	87-A00-242-090		RES,M/F 8.2K-3W J RSF(S)
CN409	87-009-033-010		CONN,5P V WHT PH	R903	87-A00-242-090		RES,M/F 8.2K-3W J RSF(S)
CNA402	8A-JE7-610-010		CONN ASSY,6P V WHT AU-MAIN	R968	87-022-382-090		RES,M/F 120-2W J
CNA403	8A-JE7-611-010		CONN ASSY,11P V WHT AU-VD	R969	87-A00-638-080		RES,M/F 47-1/2W J SPR
CNA408	8Z-JE7-663-010		CONN ASSY,2P COMB-NK	R970	87-A00-634-080		RES,M/F 2.7-1/4W J SPR
CNA414	8A-JE7-626-010		CONN ASSY,1P AU-MAIN	R971	87-A00-636-080		RES,M/F 560-1/4W J SPR
DL401	87-A91-598-010		DELAY LINE,350NS EQFK5-MT	R973	87-A00-637-080		RES,M/F 1K-1/4W J SPR
FR401	87-A00-478-090		RES,FUSE 2.2-1W J	R974	87-022-556-090		RES,M/F 180-3W J
FR402	87-A00-478-090		RES,FUSE 2.2-1W J	R976	87-A00-636-080		RES,M/F 560-1/4W J SPR
J401	87-A60-420-010		JACK,3.5 ST (MSC)	R977	87-A00-634-080		RES,M/F 2.7-1/4W J SPR
J402	87-A61-296-010		JACK,PIN 3P +S ALL GOLD YKC22-	R978	87-A00-635-080		RES,M/F 47-1/4W J SPR
L401	87-005-614-080		COIL,100UH J LAV35	SO901	8A-JE7-670-010		SOCKET,CRT 11P HPS1521-013411
L403	87-005-614-080		COIL,100UH J LAV35				
L404	87-005-614-080		COIL,100UH J LAV35	S-JK C.B			
L405	87-003-284-080		COIL,27UH J LAL02				
L406	87-003-284-080		COIL,27UH J LAL02	C771	87-010-322-080		C-CAP,S 100P-50 J CH GRM
L407	87-A50-555-010		COIL,100UH K 7212M-101K	C772	87-010-197-080		C-CAP,S 0.01-25 K B C2012
R432	87-A00-739-090		RES,M/F 1-7W K RSV7	CN771	87-009-345-010		CONN,2P H WHT PH
R447	87-A00-667-090		RES,M/F 680-2W J RSF(S)	CNA771	8Z-JE5-631-010		CONN ASSY,5P S-JK
R448	87-A00-667-090		RES,M/F 680-2W J RSF(S)	J771	87-A61-174-010		JACK,Y/CYKF51-5558
W401	8A-JE7-612-010		F-CABLE,8P 2.0 70MM				
W405	8A-JE7-613-010		F-CABLE,11P 2.0 70MM	PS C.B			
△!C881				△!C881	87-A10-688-090		CAP,M/P 0.22-275 K (B81133)
△!C883				△!C883	87-A10-688-090		CAP,M/P 0.22-275 K (B81133)
C887				C887	87-010-388-080		CAP,E 1000-25 M SME
CN881				CN881	87-A61-299-010		CONN,4P B 5-VB
CN882				CN882	87-099-674-010		CONN,2P V VA
CN883				CN883	87-A61-126-080		MALE, 1P TP42097
CN884				CN884	87-A60-937-010		CONN,2P V VH
CN885				CN885	87-A61-126-080		MALE, 1P TP42097
F881				F881	87-A91-106-010		FUSE,5A 125V T SER233
FC881				FC881	87-033-213-080		FUSE CLAMP,PFC5000
FC882				FC882	87-033-213-080		FUSE CLAMP,PFC5000
LF881				LF881	87-A91-453-010		FLTR,LINE PLH10A7003R6P02B1
LF882				LF882	87-A91-626-010		FLTR,LINE ELF21V018A
PT881				PT881	8Z-JBH-614-010		PT,US TP8155T
R881				R881	87-023-102-080		RES,SD 4.7M-1/2W K
C901	87-010-405-080		CAP,E 10-50 M 11L SME				
C902	87-010-968-080		CAP,CER 680P-2K K B				
C903	87-010-405-080		CAP,E 10-50 M 11L SME				
C906	87-010-400-080		CAP,E 0.47-50 M 11L SME				
C907	87-010-235-080		CAP,E 470-16 M SME				
C908	87-A11-108-080		CAP,TC U 680P-50 J CH				
C909	87-A11-110-080		CAP,TC U 820P-50 J CH				
C910	87-A11-108-080		CAP,TC U 680P-50 J CH				
C911	87-A11-106-080		CAP,TC U 560P-50 J CH				
C912	87-A11-106-080		CAP,TC U 560P-50 J CH				
C913	87-A11-106-080		CAP,TC U 560P-50 J CH				
C914	87-A10-052-080		CAP,E 2.2-250				

SCHEMATIC DIAGRAM – 1 (MAIN)

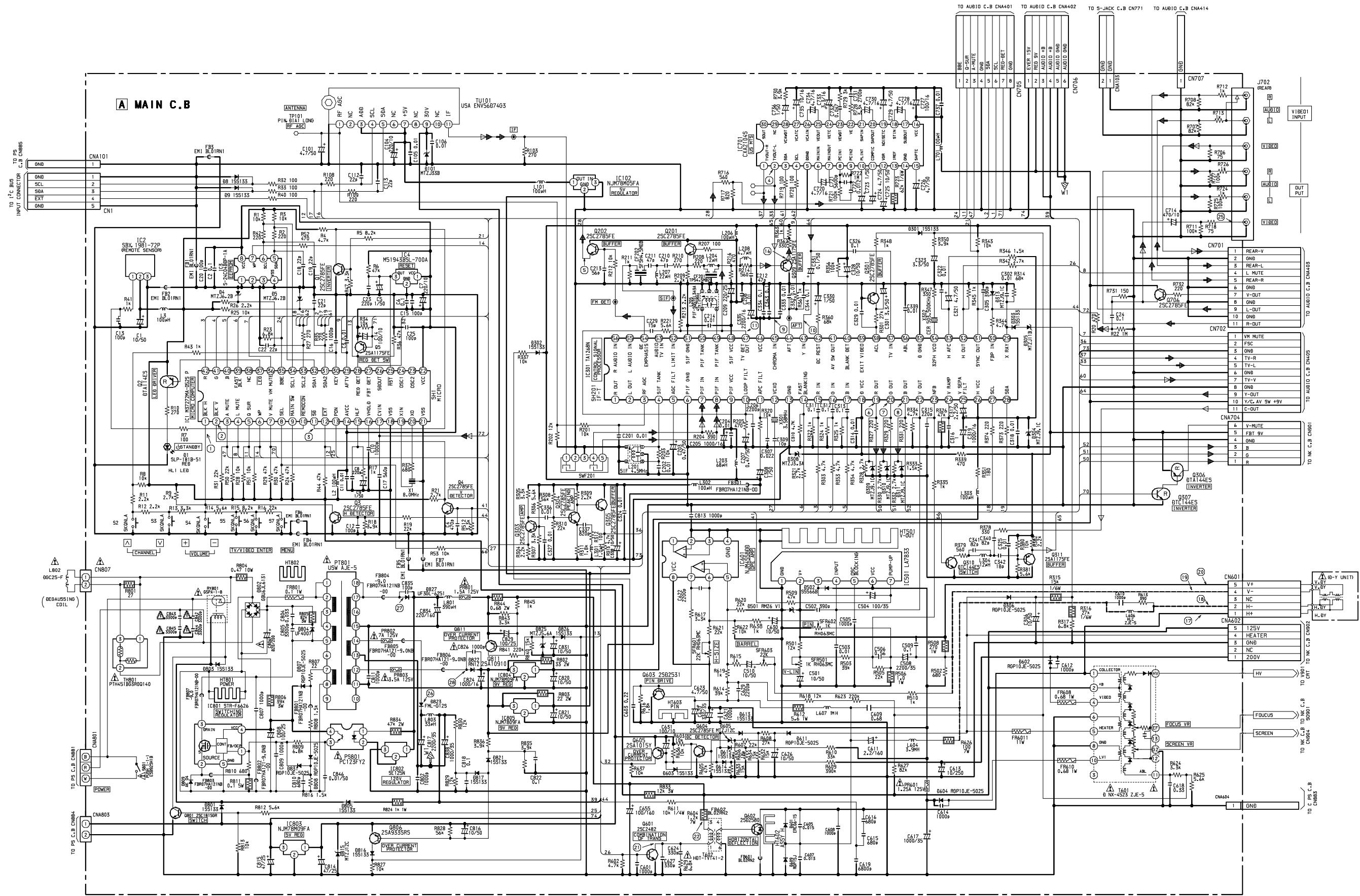

SIGNAL:
 ▲ T. R./V.B
 ▲ AUDIO
 ▲ VIDEO
 ▲ C

NOTE:
 ⊕ CHECK LAND
 ○ WAVEFORM NO.

SCHEMATIC DIAGRAM - 2 (AUDIO)

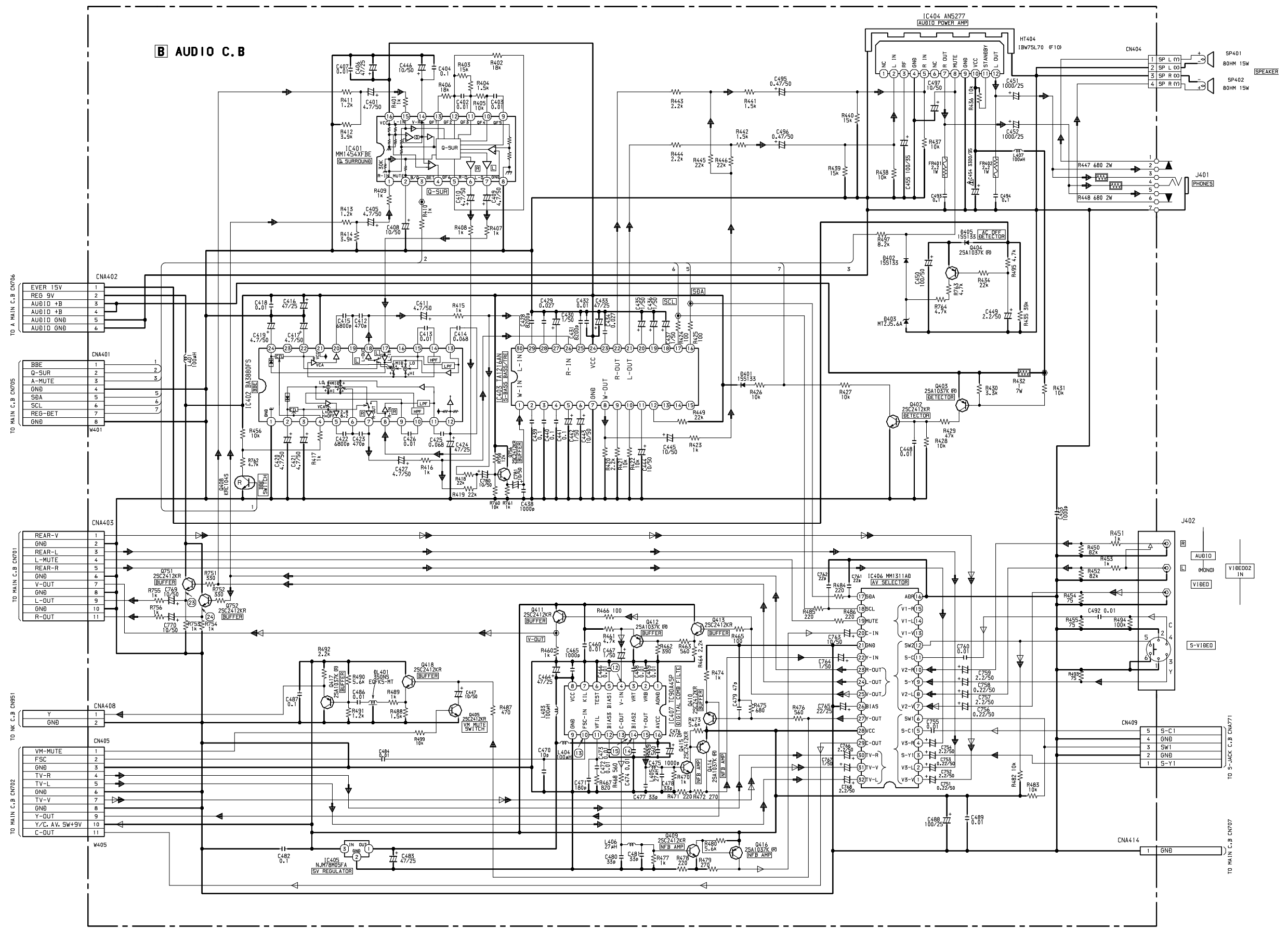

SIGNAL:
 ▲ AUDIO
 ▲ VIDEO
 ▲ C
 ▲ Y

NOTE:
 ○ CHECK LAMP
 ○ WAVEFORM NO.

SCHEMATIC DIAGRAM - 3 (NK)

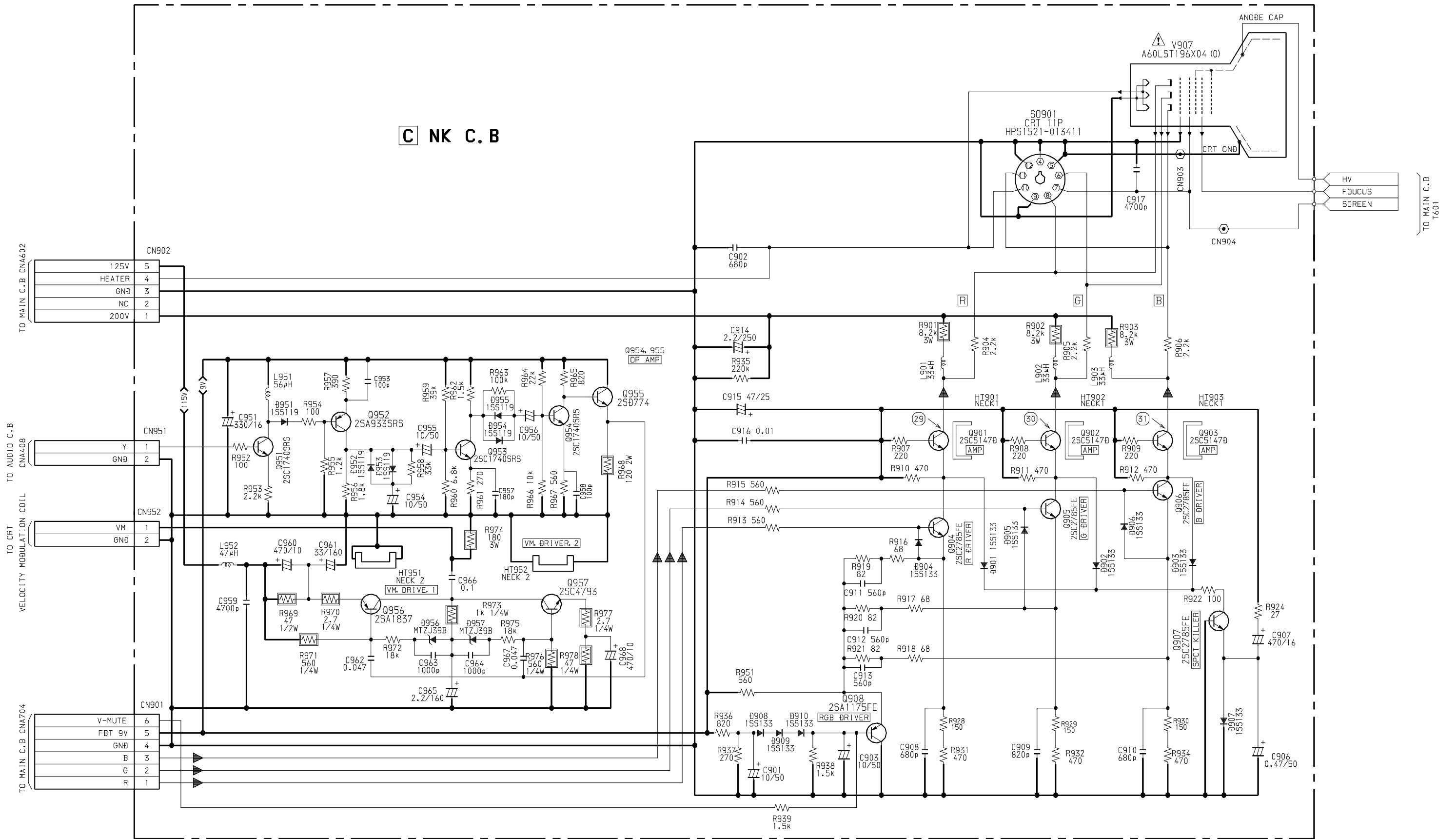

NOTE:
 ○ : WAVEFORM NO.
 SIGNAL:
 ▲ : R/G/B

SCHEMATIC DIAGRAM – 3 (PS)

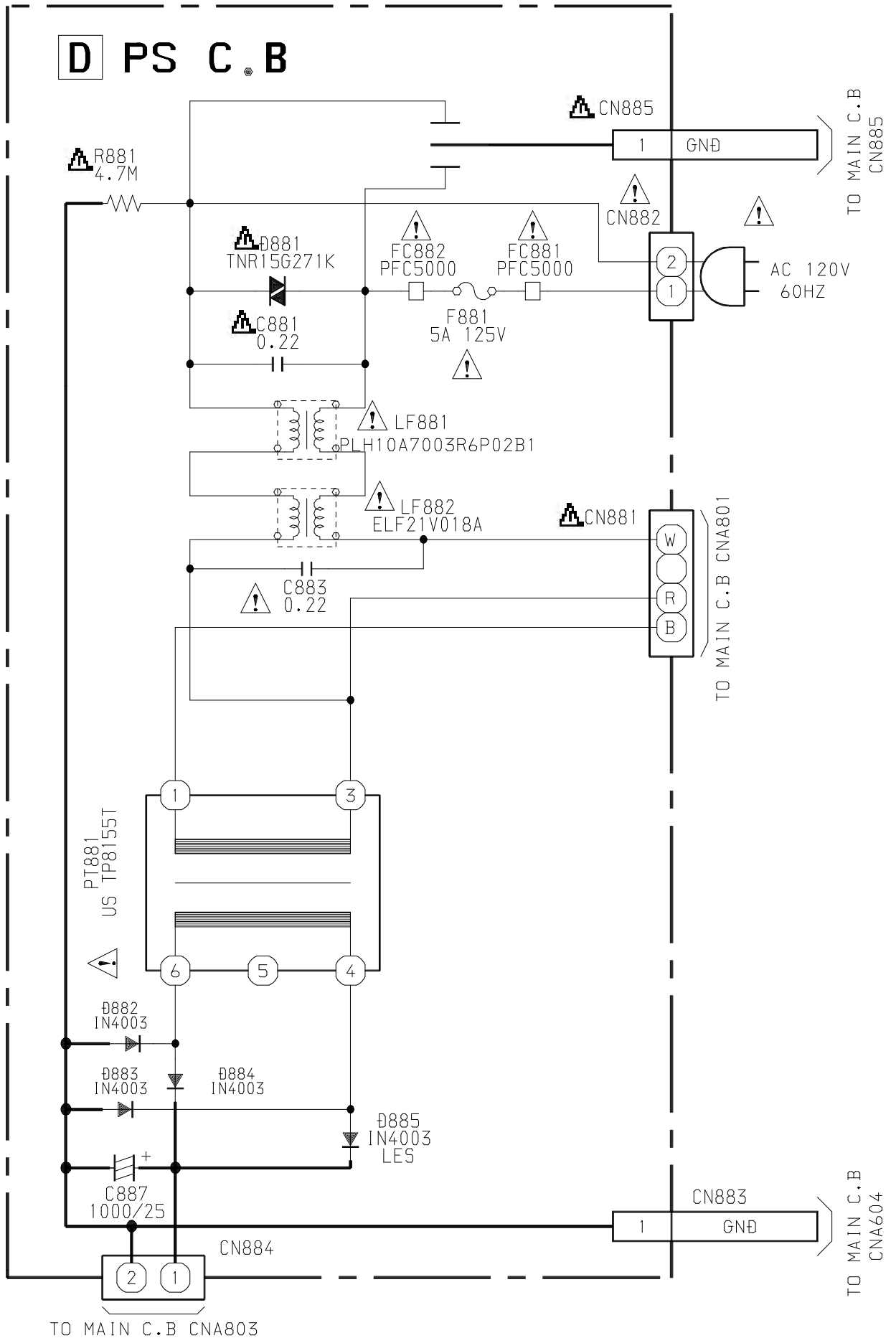

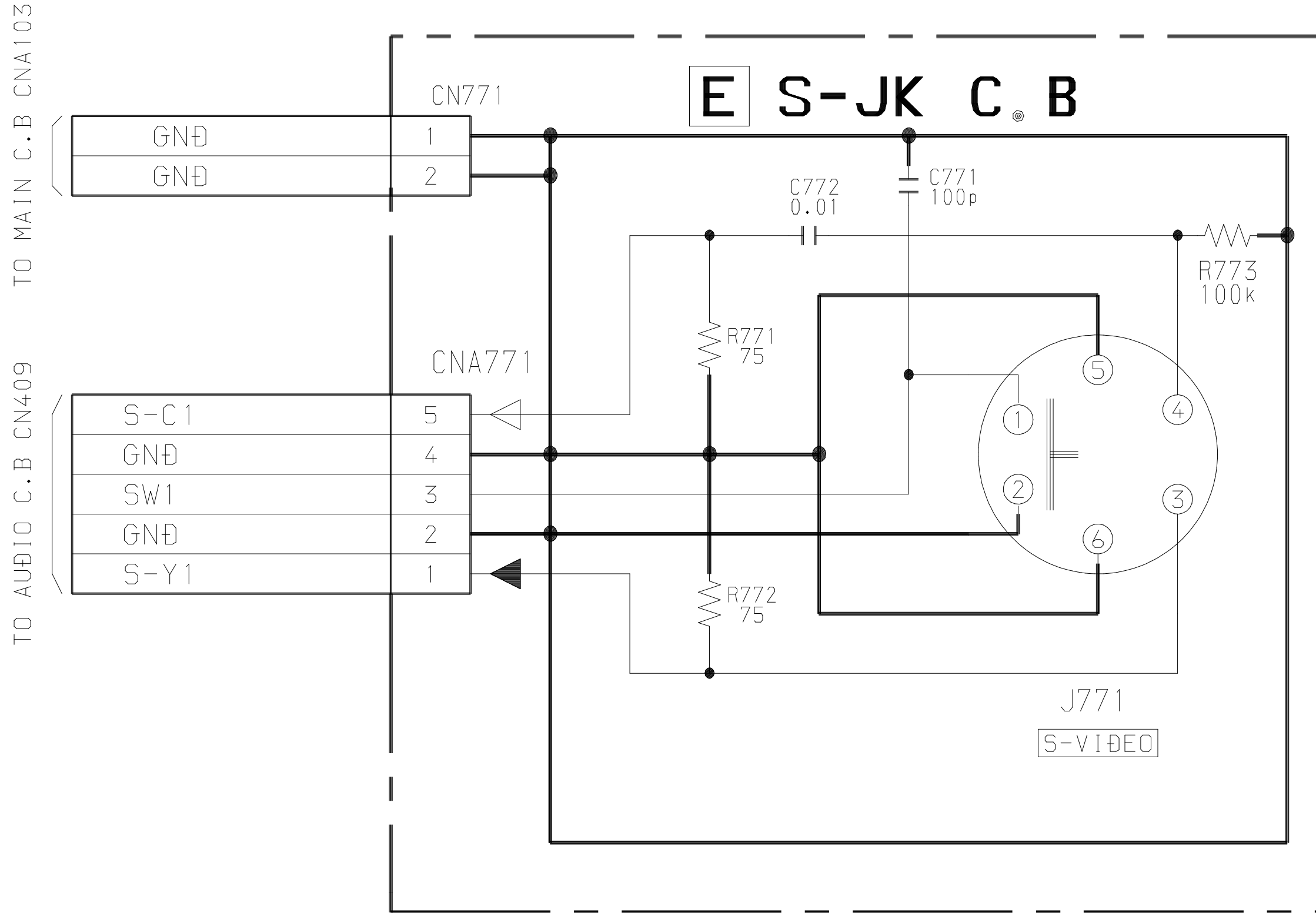

IC BLOCK DIAGRAM

IC, LA7833

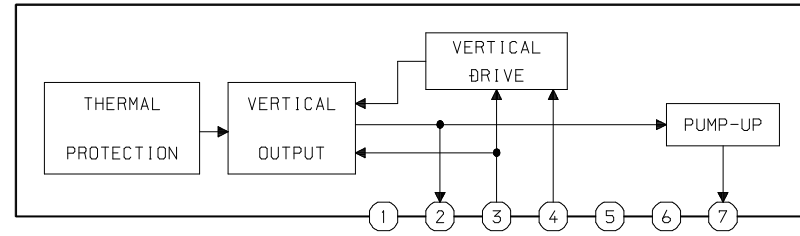

IC, TC90A45P

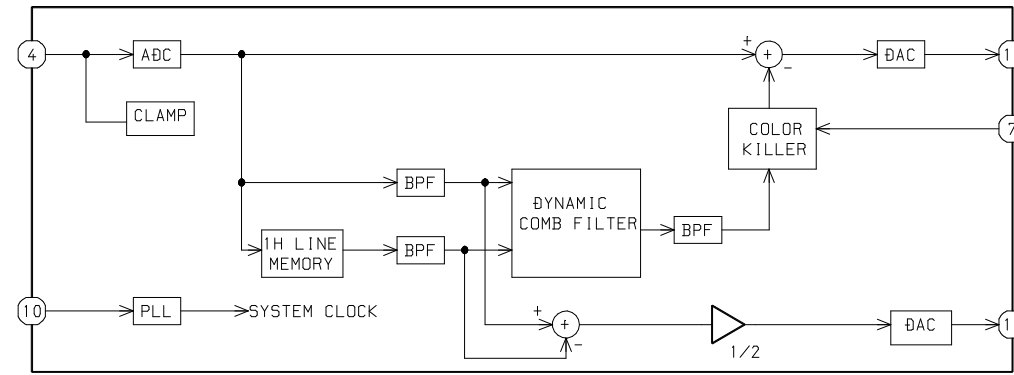

IC, BA3880FS

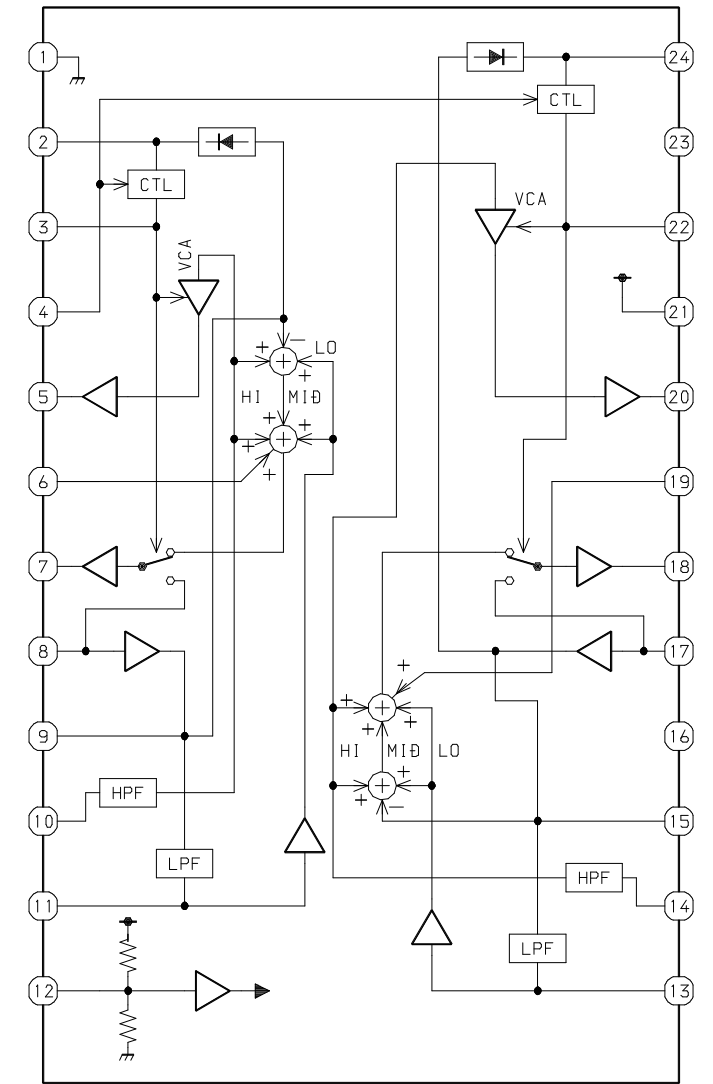

IC, AN5277

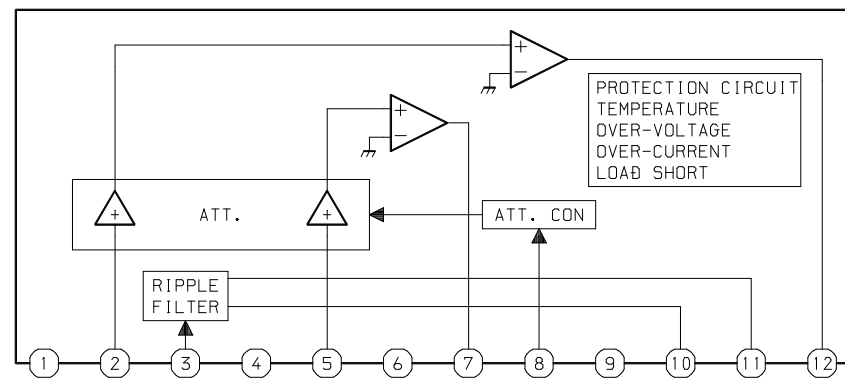

IC, TA1268N

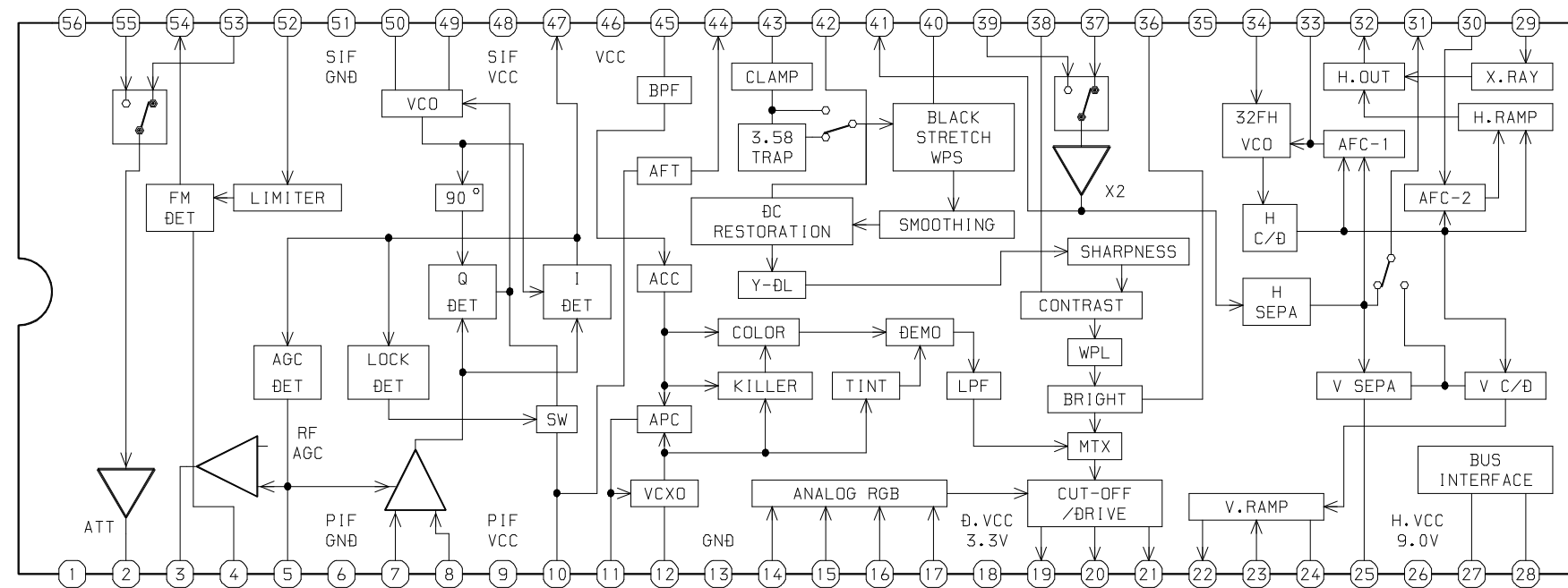

IC DESCRIPTION

IC, M37272MA-0525SP

Pin No.	Pin Name	I/O	Description
1	BLK H	I	Blanking H sync input.
2	BLK V	I	Blanking V sync input.
3	A MUTE	O	Audio Amp mute.
4	L MUTE	O	Audio mute.
5	Q SUR	O	Q surround switch.
6	WP	O	EEPROM Write protect.
7	V MUTE	O	Video mute
8	SEL	O	BPF switch.
9	MAIN SW	-	Not used.
10	REMOCON	I	Remote control signal input.
11	SD	I	Pluse check.
12	EXT	I	I ² C switch.
13	PON	O	Power switch.
14	AVCC	-	VCC.
15	HLF	-	Filter Connection Terminal.
16	VHOLD	-	Condenser Connection Terminal.
17	CV IN	I	Complex video signal input
18	VSS	-	GND.
19	XIN	I	Main Clock (8 MHz).
20	XO	O	Main Clock (8 MHz).
21	VSS	-	GND.
22	VCC	-	VCC.
23	OSC2	-	Not used.
24	OSC1	-	Not used.
25	RST	I	Reset input.
26	SDOUT	O	Not used.
27	FBT DET	O	FBT detection (over 2.5V).
28	REG DET	I	REG detection (over 2.5V).
29	AFTV	I	AFT voltage input.
30	KEY	I	Key input.
31	SDA2	I	I ² C bus CH2 data (Reg IC).
32	SDA1	I	I ² C bus CH1 data (EEPROM).
33	SCL2	I	I ² C bus CH2 data (Reg IC).
34	SCL1	I	I ² C bus CH1 data (EEPROM).
35	BBE	O	BBE switch.
36	VM MUTE	O	VM mute.
37	LED	O	Power LED switch.
38	NC	-	Not connected.
39	FAST BLK	O	OSD Blanking.
40	B	O	OSD B output.
41	G	O	OSD G output.
42	R	O	OSD R output.

VOLTAGE CHART
(POWER ON, COLOR BAR, VOLUME 10)

REF NO.	E	C	B
Q1	0	4.61	0.310

REF NO.	E	C	B
Q2	5.11	-0.42	5.05

REF NO.	E	C	B
Q3	0	4.22	0.042

REF NO.	E	C	B
Q4	0	4.83	0.12

REF NO.	E	C	B
Q5	5.06	0	5.06

REF NO.	E	C	B
Q201	4.48	8.93	5.12

REF NO.	E	C	B
Q202	2.742	8.93	3.327

REF NO.	S	D	G
Q301	-0.342	2.484	0

REF NO.	S	D	G
Q303	2.725	4.88	3.725

REF NO.	E	C	B
Q304	1.871	6.71	2.465

REF NO.	S	D	G
Q305	6.1	9	6.7

REF NO.	E	C	B
Q306	9.01	0.625	8.93

REF NO.	E	C	B
Q307	0	8.93	0.014

REF NO.	E	C	B
Q309	3.668	0	3.042

REF NO.	E	C	B
Q310	0	0.65	0.012

REF NO.	E	C	B
Q311	3.92	0	3.304

REF NO.	E	C	B
Q402	0	5.05	0

REF NO.	E	C	B
Q403	29.78	0	29.76

REF NO.	E	C	B
Q404	12.48	0.088	12.59

REF NO.	E	C	B
Q405	0	0	0.009

REF NO.	E	C	B
Q408	0	8.61	0.008

REF NO.	E	C	B
Q409	1.418	8.22	1.977

REF NO.	E	C	B
Q410	1.654	8.86	2.270

REF NO.	E	C	B
Q411	4.46	8.86	5.11

REF NO.	E	C	B
Q412	2.435	0	1.820

REF NO.	E	C	B
Q413	4.46	8.86	5.10

REF NO.	E	C	B
Q414	8.86	2.897	8.22

REF NO.	E	C	B
Q415	1.32	8.23	1.875

REF NO.	E	C	B
Q416	8.86	3.11	8.22

REF NO.	E	C	B
Q417	2.2535	0	1.896

REF NO.	E	C	B
Q418	3.562	8.86	4.2

REF NO.	E	C	B
Q601	0.004	101.1	0.33

REF NO.	E	C	B
Q602	0.013	120.2	-0.121

REF NO.	E	C	B
Q603	0.003	15.46	0.552

REF NO.	E	C	B
Q604	0	5.11	0

REF NO.	E	C	B
Q605	5.11	0	5.11

REF NO.	E	C	B
Q706	3.807	8.86	4.45

REF NO.	E	C	B
Q751	3.424	8.61	4.059

REF NO.	E	C	B
Q752	3.421	8.62	4.056

REF NO.	E	C	B
Q756	3.358	8.62	3.887

REF NO.	E	C	B
Q801	0	0.082	0.751

REF NO.	E	C	B
Q806	5.11	-0.82	5.09

REF NO.	E	C	B
Q811	123.7	-0.012	123.4

REF NO.	E	C	B
Q901	8.52	142.6	8.98

REF NO.	E	C	B
Q902	8.51	139.7	8.98

REF NO.	E	C	B
Q903	8.51	138.1	8.98

REF NO.	E	C	B
Q904	2.076	8.52	2.44

REF NO.	E	C	B
Q905	2.098	8.51	2.467

REF NO.	E	C	B
Q906	2.142	8.51	2.490

REF NO.	E	C	B
Q907	0.157	8.64	0

REF NO.	E	C	B
Q908	1.316	0	0.609

REF NO.	E	C	B
Q951	1.920	9.01	2.545

REF NO.	E	C	B
Q952	7.68	3.219	8.31

REF NO.	E	C	B
Q953	0.63	5.53	1.273

REF NO.	E	C	B
Q954	2.060	5.96	2.709

REF NO.	E	C	B
Q955	5.34	9.01	5.95

REF NO.	E	C	B
Q956	123	61.8	122.5

REF NO.	E	C	B
Q957	0.188	61.8	0.743

IC1, M37272MA-052SP

PIN NO.	VOLT (V)
1	4.22
2	4.83
3	0.022
4	0.02
5	0.029
6	5.11
7	0.015
8	0.014
9,10	5.09
11	4.61
12	5.09
13	5.01
14	5.06
15	1.978
16	0.336
17	2.328
18	0
19	2.288
20	2.339
21	0
22	5.06
23	5.04
24	5.06
25	5.04
26	5.06
27	0
28	2.481
29	2.48
30	5.11
31	3.83
32	5.06
33	4.15
34	5.06
35	0.009
36	0.01
37,38	5.05
39~42	0.011

IC2, SBX1981-72P

PIN NO.	VOLT (V)
1	5.09
2	5.11
3	0

IC3, S-24CO4BDP-1A

PIN NO.	VOLT (V)
1~4	0
5,6	5.05
7	5.11
8	5.06

IC4, M51943BSL-700A

PIN NO.	VOLT (V)
1	5.06
2	0
3	5.03

IC102, NJM78M05FA

PIN NO.	VOLT (V)
1	5.09
2	0
3	9.02

IC301, TA1268N

PIN NO.	VOLT (V)
1	0.025
2	3.946
3	0.002
4	3.257
5	0.696
6	0
7	1.99
8	1.989
9	8.97
10	4.45
11	6.35
12	4.83
13	0
14	0.008
15,16	4.86
17	4.83
18	3.195
19	2.406
20	2.441
21	2.459
22	0.754
23	4.99
24	5.09
25	6.6
26	9.05
27	4.1
28	3.83
29	2.626
30	1.331
31	1.145
32	1.246
33	7.61
34	6.61
35	0
36	3.112
37	3.263
38	3.993
39	1.812
40	5.22
41	4.07

PIN NO.	VOLT (V)
42	4.77
43	4.71
44	2.476
45	3.921
46	9.03
47	5.13
48	8.93
49,50	7.94
51,52	0
53	3.534
54	3.529
55	2.786
56	0

IC401, MM1454XFBE

PIN NO.	VOLT (V)
1	3.972
2	3.973
3	0.027
4	0.007
5	3.979
6,7	3.984
8	0
9,10	3.981
11	3.98
12,13	3.982
14	4.62
15	3.972
16	8.62

IC402, BA3880FS

PIN NO.	VOLT (V)
1	0
2	4.29
3	6.2
4	8.61
5~15	4.43
16	0
17~20	4.43
21	8.62
22	6.15
23	0
24	4.29

IC403, TA1216AN

PIN NO.	VOLT (V)
1	4.81
2	5.43
3	5.37
4	5.45
5	0.23
6	5.54
7	0
8	3.896
9,10	0.013
11	4.76
12	0.062
13	0.678
14	0.71
15	5.12
16	3.84
17	4.15
18	4.73
19	1.794
20	4.67
21,22	4.17
23	4.84
24	8.62
25	4.83
26	4.82
27	4.67
28	4.84
29	4.83
30	4.82

IC404, AN5277

PIN NO.	VOLT (V)
1~2	0
3	28.47
4~6	0
7	14.34
8	0.622
9	0
10	29.73
11	18.94
12	14.36

IC405, NJM78M05FA

PIN NO.	VOLT (V)
1	5.12
2	0
3	8.86

IC406, MM1311AD

PIN NO.	VOLT (V)
1	4.63
2	4.88
3	4.22
4	4.87
5	4.2
6	8
7	4.22
8	4.87
9	4.22
10	4.87
11	4.2
12	8
13	4.33
14,15	4.88
16	0
17	3.84
18	4.15
19	0.018
20	4.19
21	0
22	5.14
23	4.062
24	4.064
25	5.11
26	4.24
27	4.2
28	8.86
29	3.435
30	4.87
31	4.22
32	4.87

IC407, TC90A45P

PIN NO.	VOLT (V)
1	0
2	2.237
3	2.801
4	2.422
5	1.275
6,7	0
8	5.08
9	0
10	2.162
11	2.033
12	3.424
13	3.092
14	1.546
15	2.945
16	5

IC501, LA7833

PIN NO.	VOLT (V)
1	0
2	16.58
3	27.18
4	0.747
5	0.751
6	26.55
7	2.661

IC601, NJM4558DD

PIN NO.	VOLT (V)
1	26.13
2~4	0.005
5	5.15
6	5.16
7	4.82
8	26.55

IC701, CXA2104S

PIN NO.	VOLT (V)
1,2	4.065
3	3.83
4	4.1
5	0
6	4.051
7	3.877
8	4.046
9	3.837
10	5.15
11	4.045
12	1.254
13	1.254
14	0
15	4.31
16	8.77
17	4.048
18	4.057
19	3.95
20	4
21	4.05
22	3.94
23	4.051
24	1.745
25	4.064
26	4.052
27	1.703
28	3.903
29	-0.013
30	4

IC802, SE120N

PIN NO.	VOLT (V)
1	124.4
2	91.2
3	0

IC803, NJM78M05FA

PIN NO.	VOLT (V)
1	5.11
2	0
3	12.51

IC804, NJM78M09FA

PIN NO.	VOLT (V)
1	8.87
2	0
3	11.77

IC805, NJM7809FA

PIN NO.	VOLT (V)
1	9.04
2	0
3	11.77

TU101

PIN NO.	VOLT (V)
1	0
2	9.3
3	4.8
4	4.15
5	3.82
6	0
7	4.8
8	0
9	32.49
10,11	0

WAVEFORM

① IC1 PIN 1 ($\overline{\text{BLK H}}$)

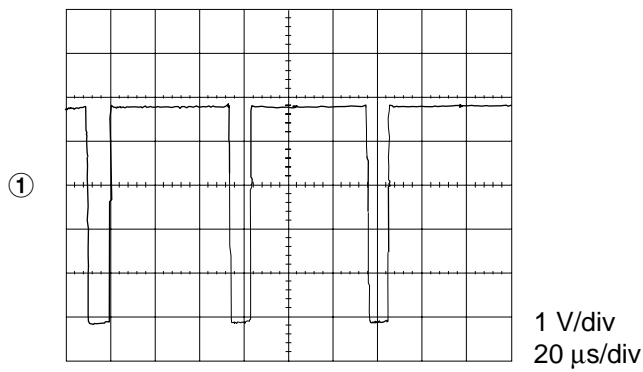

⑤ Q202 EMITTER

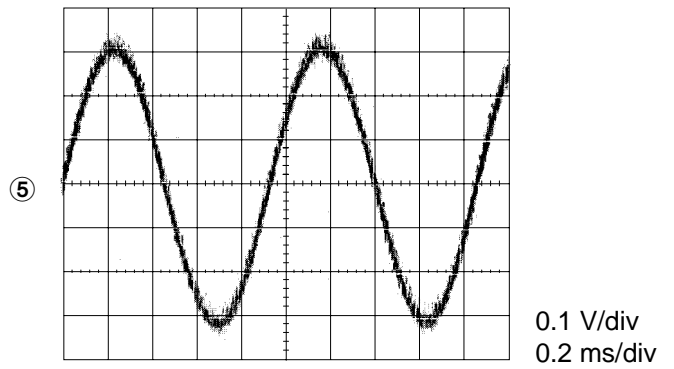

② IC1 PIN 2 ($\overline{\text{BLK V}}$)

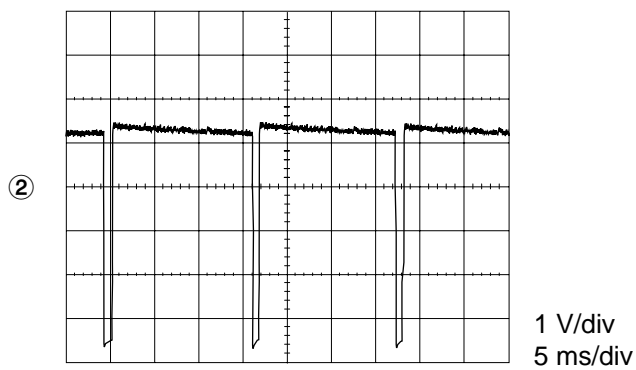

⑥ IC301 PIN 19 (R OUT)

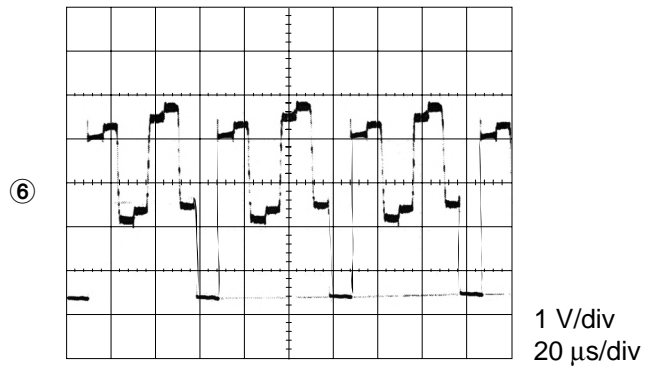

③ IC1 PIN 11 ($\overline{\text{SD}}$)

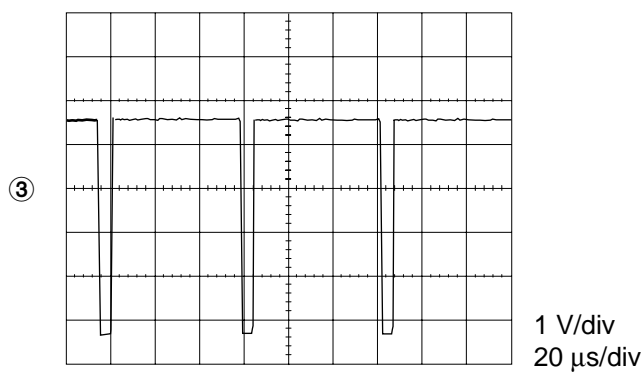

⑦ IC301 PIN 20 (G OUT)

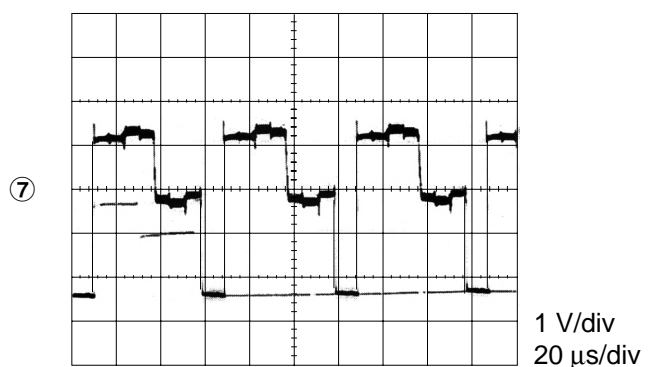

④ IC701 PIN 2 (TVOUT-L)

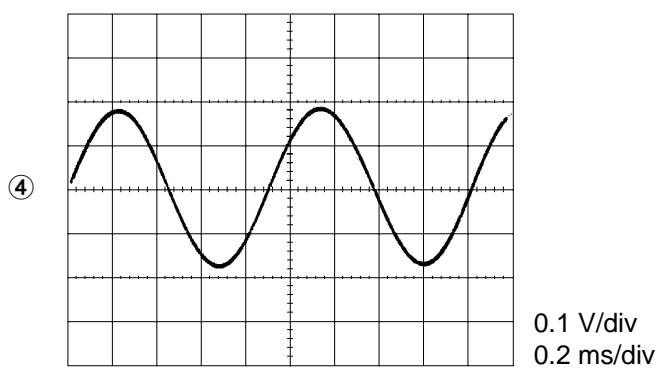

⑧ IC301 PIN 21 (B OUT)

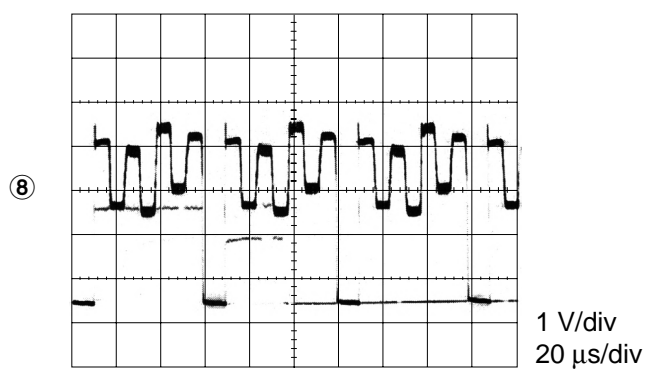

⑨ IC301 PIN 45 (CHROMA IN)

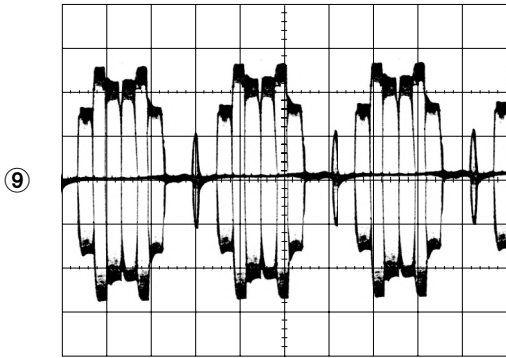

0.1 V/div
20 μs/div

⑬ IC407 PIN 10 (FSC-IN)

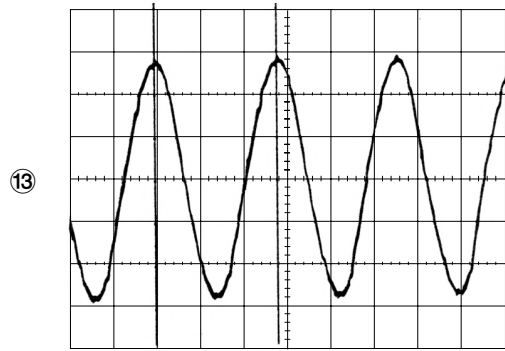

0.2 V/div
0.1 μs/div

⑩ IC301 PIN 43 (Y IN)

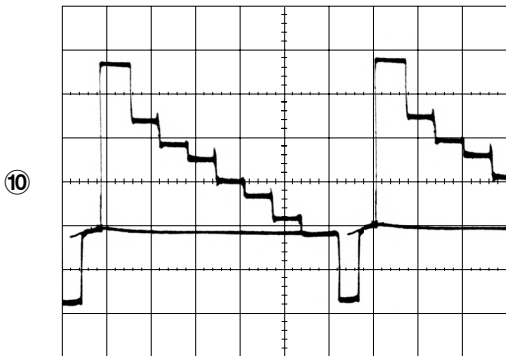

0.2 V/div
10 μs/div

⑭ IC407 PIN 13 (C-OUT)

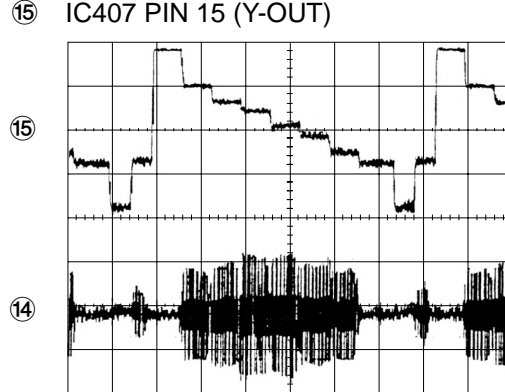

0.5 V/div
10 μs/div

⑮ IC407 PIN 15 (Y-OUT)

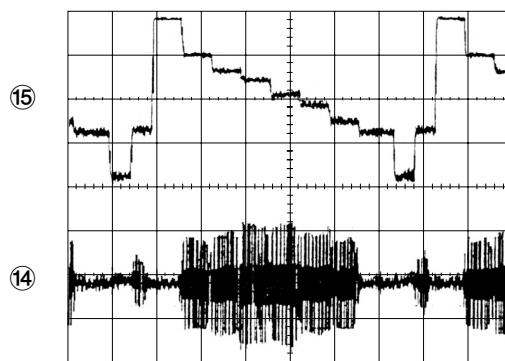

0.2 V/div
10 μs/div

⑪ IC301 PIN 47 (TV DET OUT)

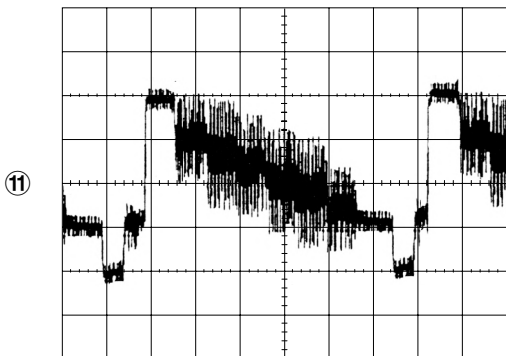

0.5 V/div
10 μs/div

⑯ Q309 EMITTER

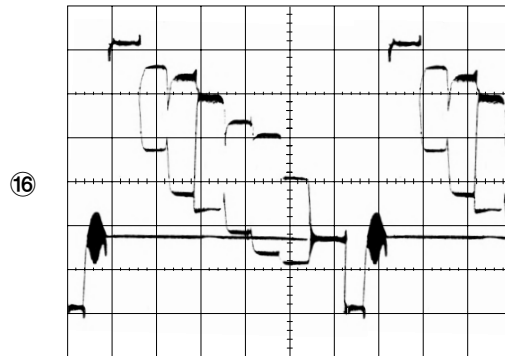

0.2 V/div
10 μs/div

⑫ IC407 PIN 4 (V-IN)

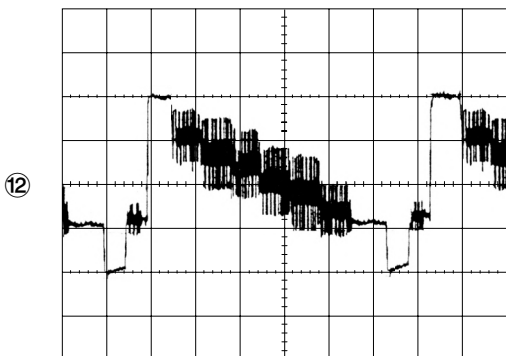

0.2 V/div
10 μs/div

⑰ CN601 PIN 1 (H+)

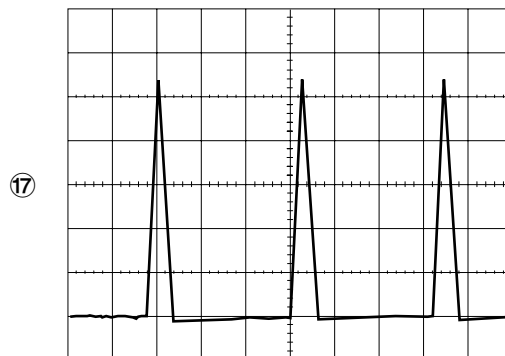

200 V/div
20 μs/div

⑱ CN601 PIN 2 (H-)

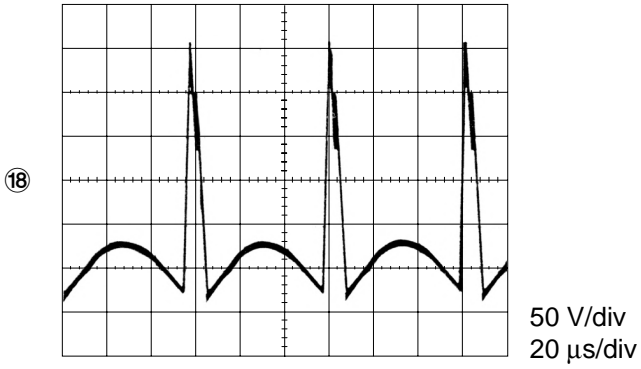

㉒ T602 PIN 3

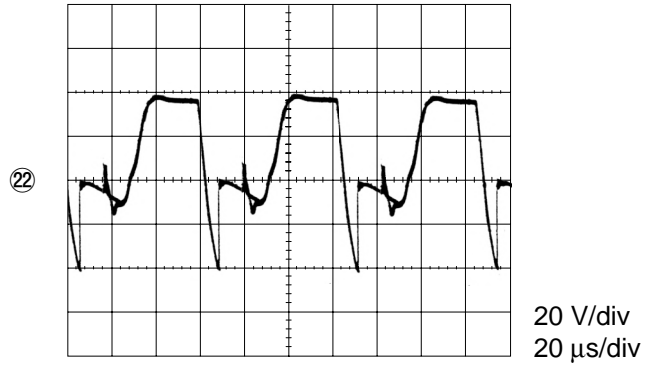

⑲ CN601 PIN 4 (V-)

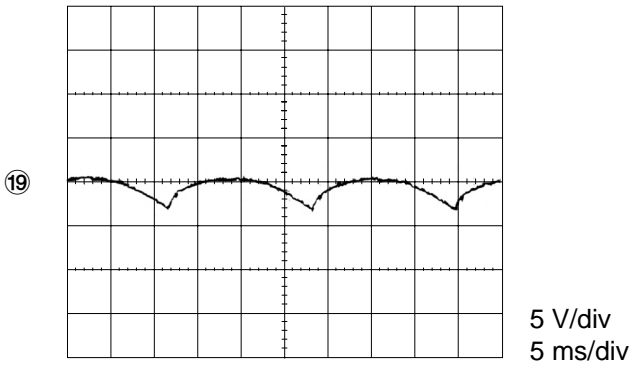

㉓ Q751 (EMITTER)

㉔ Q752 (EMITTER)

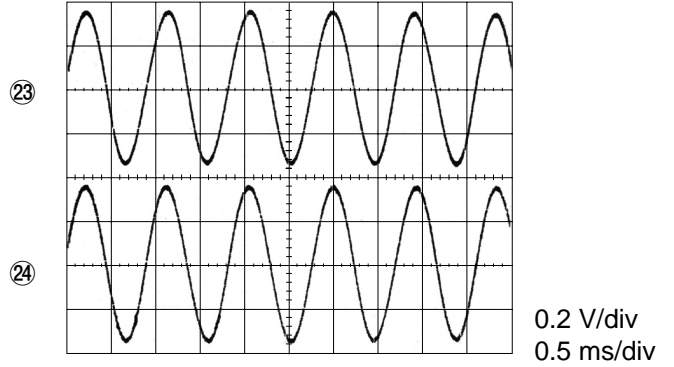

⑳ CN601 PIN 5 (V+)

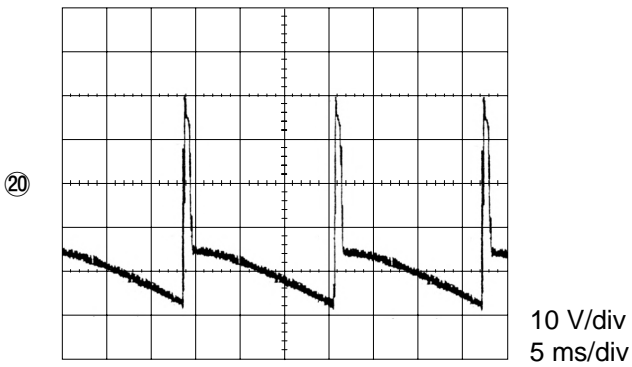

㉕ J702 (VIDEO OUTPUT)

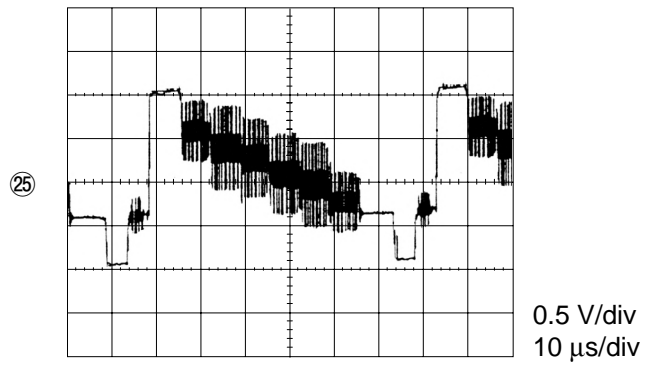

㉑ Q601 COLLECTOR

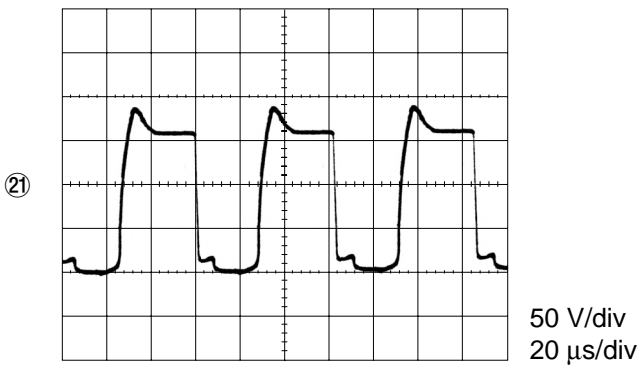

㉖ D823 ANODE (at POWER ON)

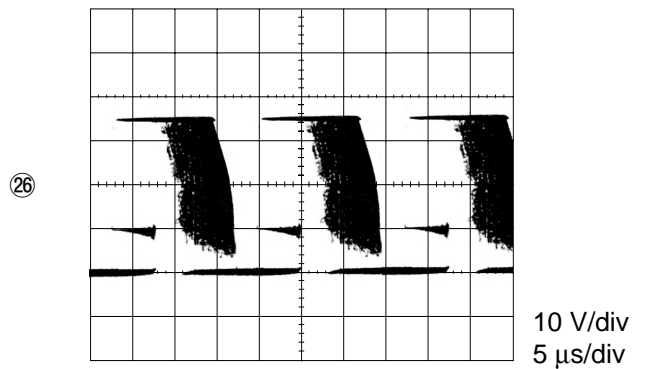

②⑦ D827 ANODE (at POWER ON)

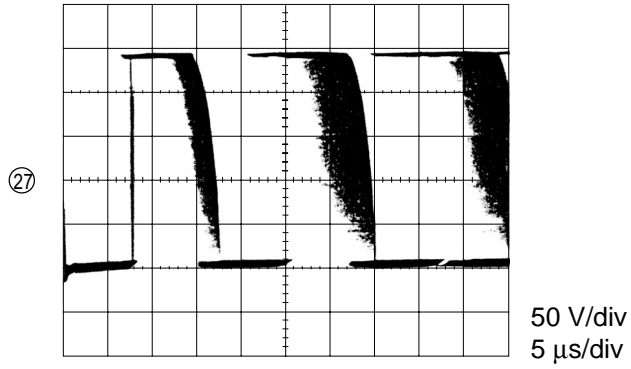

③① Q903 COLLECTOR (B-DRIVE)

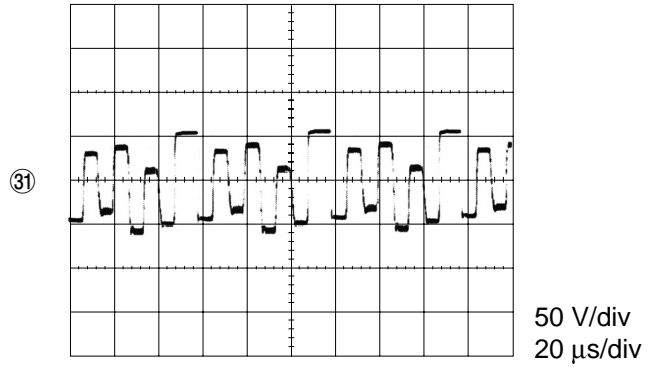

②⑧ D822 ANODE (at POWER ON)

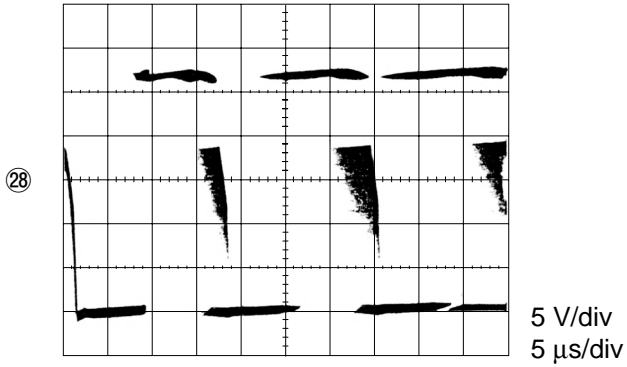

②⑨ Q901 COLLECTOR (R-DRIVE)

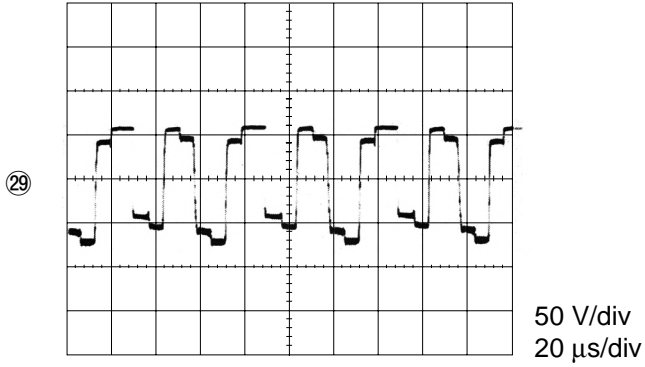

③① Q902 COLLECTOR (G-DRIVE)

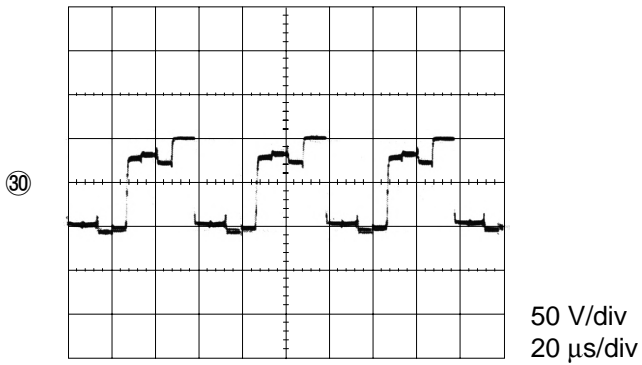



TV-F2400 TV-F2500

U
NH,HT

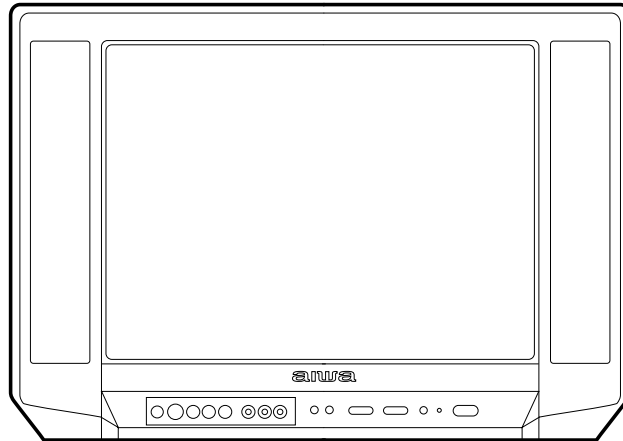

SERVICE MANUAL

COLOR TELEVISION

- This Service Manual contains the additional information "NOTE ON BEFORE REPAIRING", "SETTING OF IIC BUS DATA" and "ADJUSTMENT" for the model TV-F2400/2500(U,NH,HT). If requiring the other information, see Service Manual of TV-F2400(U),(S/M Code No. 09-007-431-9R1) and TV-F2500(NH,HT), (S/M Code No. 09-008-431-9R2).

aiwa
S/M Code No. 09-009-431-9S2

SUPPLEMENT
DATA

Setting of IIC BUS Data

This model is designed with the ability to adjust most parts of the image projection and deflection system by using the jig remote controller.

Preparations :

- Modify the hidden keys on the RC-6VT06 jig remote controller (TV-C142/86-LB4-951-010) so that they can easily be pressed. 2 keys to be modified. (Refer to the below illustration)

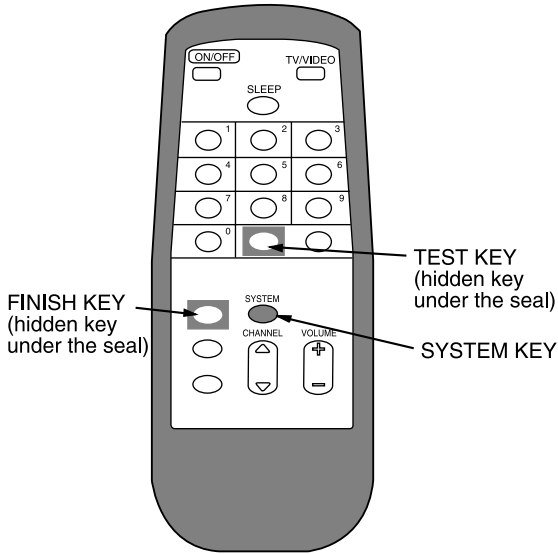

Starting the "Service Mode" :

Hidden key / "TEST"

- Press the "TEST" key on the jig remote controller once to enter to the "Aging Mode" (Refer Fig. 1).
- Press the "TEST" key on the jig remote controller again to enter the "Adjustment Mode".

Hidden key / "FINISH"

- The accumulated hours in the "Aging Mode" will be reset by pressing the "FINISH" key on the jig remote controller.
- Avoid to press this key during general repairs.

Aging Mode Operation Method :

Make sure that confirmation is done after replacing the EEPROM.

<TV-F2400>

1. Enter to the aging mode by pressing the "TEST" key on the remote controller. (Fig. 1a)

```
AGING AFT OK 0000H US25
```

Fig.1a

2. Press "SYSTEM" key and confirm the condition of the distinction switch. (Fig. 2a)

Confirm the following items before doing the electrical adjustment.

- In case the contents are different, press "5" key and select [US25] for the destination.
- In case the data is different use the "CHANNEL" key to scroll through 0~F and set to the correct data value of "0" or "1" by the volume key.
- All the settings are stored when the "TEST" key is pressed to complete the correction.

```
AGING AFT OK 0000H NH25
```

Fig.1b

1	US21
2	TW21
3	NH21
4	NH25
5	US25
6	TW25
	0 1 2 3 4 5 6 7 8 9 A B C D E F
	0 1 1 1 0 1 1 1 1 1 1 1 1 1 0 0

Fig.2a

<TV-F2500>

1. Enter to the aging mode by pressing the "TEST" key on the remote controller. (Fig. 1b)

2. Press "SYSTEM" key and confirm the condition of the distinction switch. (Fig. 2b)

Confirm the following items before doing the electrical adjustment.

- In case the contents are different, press "4" key and select [NH25] for the destination.
- In case the data is different use the "CHANNEL" key to scroll through 0~F and set to the correct data value of "0" or "1" by the volume key.
- All the settings are stored when the "TEST" key is pressed to complete the correction.

1	US21
2	TW21
3	NH21
4	NH25
5	US25
6	TW25
	0 1 2 3 4 5 6 7 8 9 A B C D E F
	0 1 1 1 0 1 1 1 1 1 1 0 1 1 0 0

Fig.2b

Contents of Aging Mode :

1. Release "Auto Power Off" function
 Release "Auto Power Off" function when no input is supplied.
 Use this mode for warming up (aging) during CRT adjustment.
2. AFT S-curve status indication
 The condition of FT S-curves are indicated by "OK" for suitable tuning, "UP" for too high or "DN" for too low.

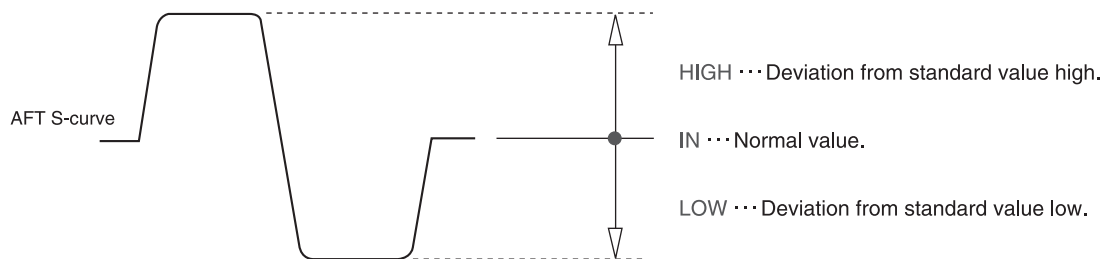

3. Display of "CRT ON" accumulated hours
 The CRT usage time is accumulated on an hourly basis and is displayed in hexadecimal figures.

Sample calculation of displayed hexadecimal figures: AFT OK 1234 H US25

$$\begin{array}{ccccccc}
 & & 1 & 2 & 3 & 4 & H \\
 & \swarrow & & \swarrow & \swarrow & \swarrow & \\
 1 \times 16^3 & + & 2 \times 16^2 & + & 3 \times 16^1 & + & 4 \times 16^0 = 4660 \text{ hours} \\
 \text{4th digit} & & \text{3rd digit} & & \text{2nd digit} & & \text{1st digit}
 \end{array}$$

- The display will be reset to 0000H when the accumulated hours exceed 7FFFH(32768 hours).

Adjustment Mode Operation Method :

1. Return to the aging display by pressing the "SYSTEM" key and press "TEST" key to display the adjustment menu screen.

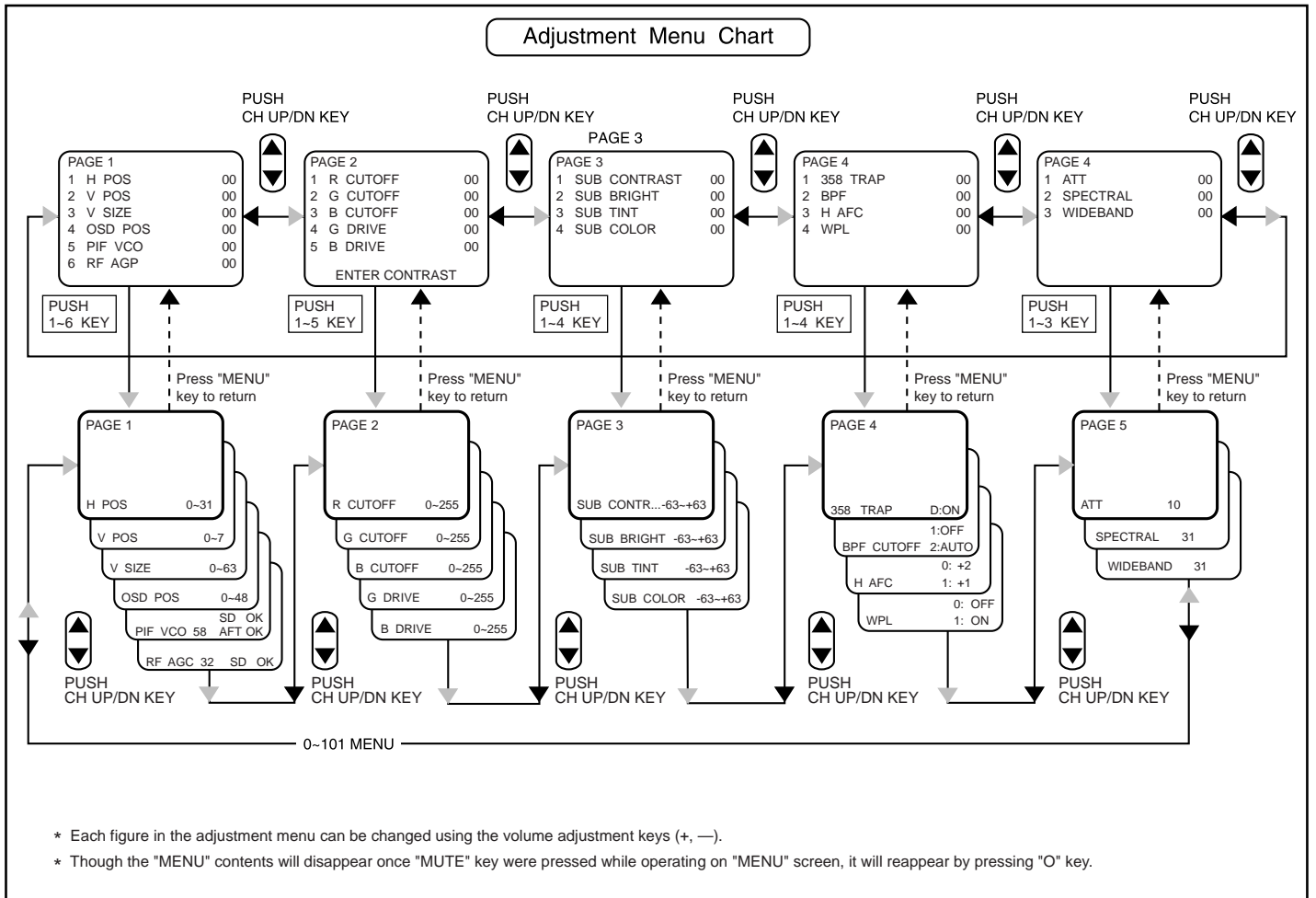

Fig.3

ADJUSTMENT

Electrical adjustment:

- Operate after inputting the following initial figures when replacing EEP ROM.
- Check the condition and adjust the area where the general repair is carried out.

	Initial Value
PAGE 1	
1. H POS	16
2. V POS	3
3. V SIZE	30
4. OSD POS	6
5. PIF VCO	58
6. RF AGC	32
PAGE 2	
1. R CUT OFF	127
2. G CUT OFF	127
3. B CUT OFF	127
4. G DRIVE	127
5. B_DRIVE	127
PAGE 3	
1. SUB CONTRAST	- 5
2. SUB BRIGHT	+ 32
3. SUB TINT	+ 16
4. SUB COLOR	+ 16
PAGE 4	
	Specific Value
1. 3.58 TRAP	OFF
2. BPF	AUTO
3. H AFC	+ 1
4. WPL	OFF
PAGE 5	
1. ATT	10
2. SPECTRAL	24
3. WIDEBAND	44

PWB Adjustment / Do before entering the adjustment mode

1. **H SIZE** Horizontal Size Crosshatch

Input Signal : Crosshatch

Adjustment Point : SFR601

Measuring Instrument : Pattern generator / reader: LCG-401

- Use SFR601 to adjust the dot mark of the crosshatch to the center.
(So that the number of measure become the same horizontally and vertically)

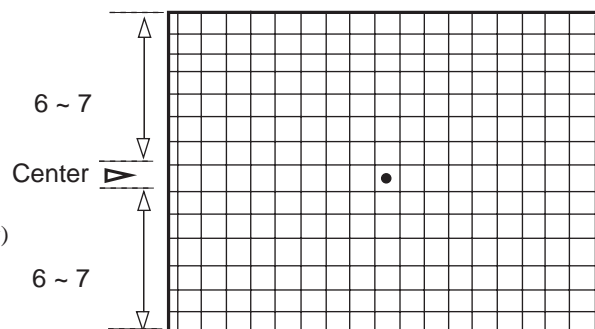

2. **PIN & BARREL** Pin Phase & Pin Amplitude (Barrel) Adjustment (Linearity).

Input Signal : Crosshatch

Adjustment Point : SFR602 / **PIN** (Fig. A)

SFR603 / **BARREL** (Fig. B)

Measuring Instrument : Pattern generator / reader: LCG-401

- Adjust the crosshatch distortion.
 1. Use SFR602 to adjust the vertical distortion (Fig. A).
 2. Use SFR603 to adjust the horizontal distortion (Fig. B).
- Repeat 1~2 until the vertical lines become straight.

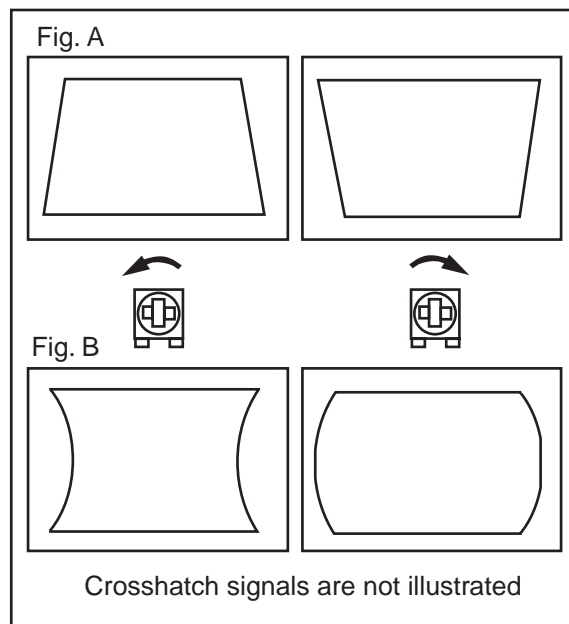

PAGE 1

1-1. **H POS** Horizontal Positioning Adjustment / Adjustment Menu Screen: PAGE 1-1

Input Signal : Crosshatch

Measuring Instrument : Pattern generator / reader: LCG-401

- Use the volume keys on the jig remote controller to adjust the dot mark in the centre of crosshatch screen to the exact centering position by allocating an equal number of squares on the left and right side of the dot. (Fig. 1-1)

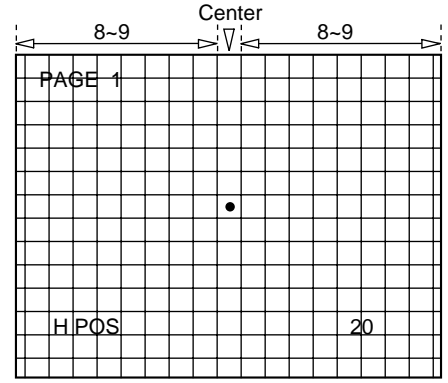

Fig. 1-1

1-2. **V POS** Vertical Positioning Adjustment / Adjustment Menu Screen: PAGE 1-2

Input Signal : Crosshatch

Measuring Instrument : Pattern generator / reader : LCG-404

- Using the volume keys on the jig remote controller to adjust the dot mark to the exact vertical centre position in the crosshatch screen. (Fig. 1-2)

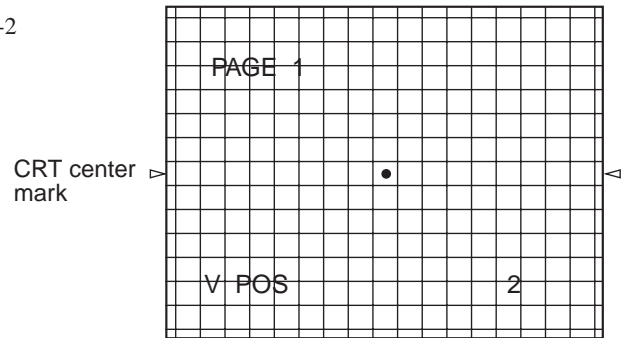

Fig. 1-2

V LINEARITY Vertical Linearity Adjustment

Input Signal : Monoscope (LION MARK)

Measuring Instrument : Monoscope / NTSC

Use the volume key on the jig remote controller to adjust the 6 circular figures on monoscope to be true circles.

<Simple Adjustment>

Input Signal : Crosshatch

Adjustment Location : SFR501

Measuring Instrument : Pattern generator / NTSC

Adjust SFR501 so that the crosshatch patterns is square.

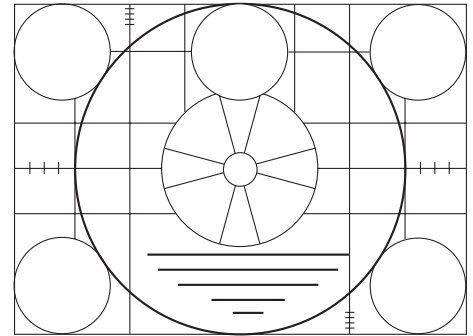

* Adjust V POS (PAGE 1-2) and Linearity repeatedly. If it does not work, adjust V Size (PAGE 1-3) first and try the adjustment again.

1-3 **V SIZE** Vertical Size Adjustment / Adjustment Menu Screen : PAGE 1-3

Input Signal : Crosshatch

Measuring Instrument : Pattern generator / reader : LCG-401

- Use the volume keys on the jig remote controller to adjust the number of the squares of the crosshatch pattern to 13~14. (Fig. 1-3)

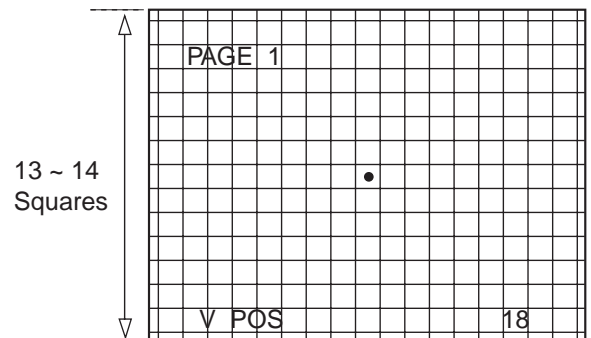

Fig. 1-3

1-4. **OSD POS** OSD Positioning Adjustment / Adjustment Menu Screen: PAGE 1-4

Input Signal: Not specified.

- Use the volume keys on the jig remote controller to adjust the position of the + sign on both right and left sides shown on the OSD screen to be equivalent from the screen edge. A=B Fig. 1-4

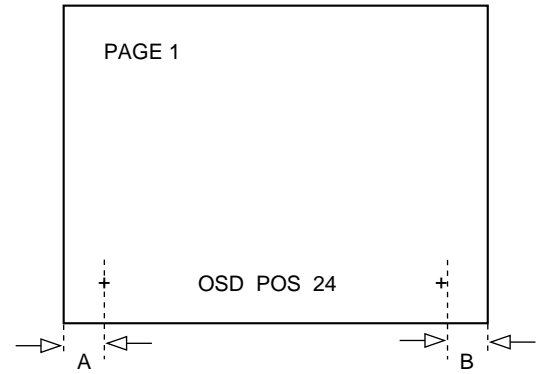

Fig. 1-4

1-5. **PIF VCO** Video IF/ VCO Adjustment / Adjustment Menu Screen: PAGE 1-5

Input Signal: ANT RF-INPUT
Colour Bar

Measuring Instrument: Oscilloscope Pattern generator / reader: LCG-401

- Use the volume keys on the jig remote controller to adjust the status of AFT on the screen to “OK”. Fig. 1-5
- If “OK” status can be obtained from multiple numbers of ranges, select the intermediate value.

* SD will display “NG” while the screen has no signals. There will be no problem with VCO Adjustment. (e.g. when there is no signal with Video input) In this case, it is possible to make adjustments as long as ANT is loaded.

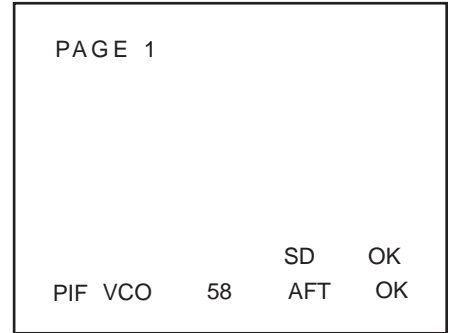

Fig. 1-5

1-6. **RF AGC** RF-AGC/ Adjustment Menu Screen: PAGE1-6

Input Signal: ANT RF-INPUT
Color Bar

Test Point: TP101 **RF AGC**

Measuring Instrument: Oscilloscope
Pattern generator / reader: LCG-401

1. Connect the oscilloscope to TP101.
2. Using the volume keys on the jig remote controller to adjust the test point voltage value to $4.0 \pm 0.5\text{VDC}$. Then check if the status of AFT on the Adjustment Menu Screen is displayed “OK” as shown in Fig. 1-6.

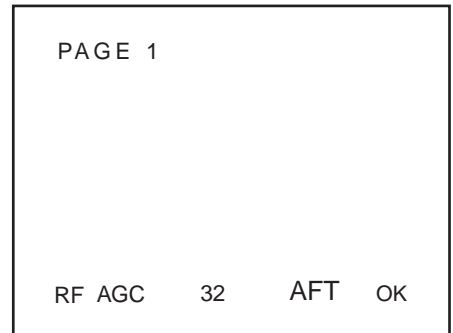

Fig. 1-6

PAGE 2

White Balance Adjustment : Adjustment Menu Screen: PAGE 2-1~5

*User's picture quality will be cleared when the adjustment menu screen appears.

Input signal : White raster

Contents of Adjustment :

1. R CUT OFF
2. G CUT OFF
3. B CUT OFF
4. G DRIVE
5. B DRIVE

* More than 20 minutes of aging is required before the adjustment.

* The whole process should be repeated several times for the adjustment.

Measuring instrument : Pattern generator / reader: LCG-401

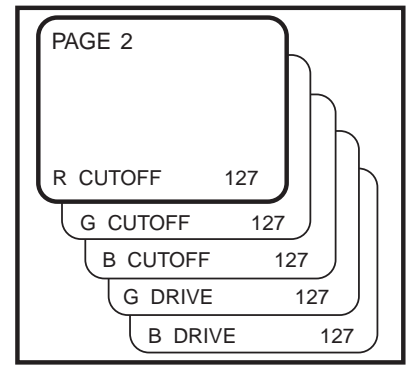

Fig. 2-1

Cut Off Adjustment :

- 2-1. Use the pattern generator to input the white raster signal.
- 2-2. Using the volume keys on the jig remote controller, fix the figure of the strongest color on the screen to 127 and adjust the other 2 cut off figures until white picture appears on the screen.

Drive Adjustment :

- 2-3. Using the volume keys on the jig remote controller, bring the figure of the [4.G DRIVE] up to more than 200 till the color becomes greenish.
- 2-4. Then reduce the numeric figure to the point where the greenish color disappears completely.
- 2-5. Using the volume keys on the jig remote controller, bring the figure of the [5.B DRIVE] up to more than 200 till the color becomes bluish.
- 2-6. Then reduce the numeric figure to the point where the bluish color disappears completely.
- 2-7. Repeat the process of 1~6 for several times and adjust for whiter look.

Focus Adjustment :

Input Signal : Dot pattern

Adjustment Point : SFR located at upper part of FBT (T601)

Measuring Instrument : Pattern generator / reader: LCG-401

- Adjust SFR which is located at upper part of FBT (T601) in order to get the best focus for the dot.

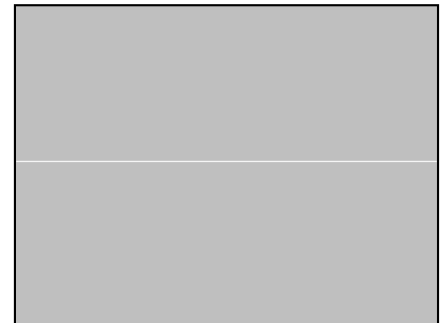

Fig. 2-2

Screen Adjustment :

Input Signal : No Signal (No Raster)

Adjustment Point : SFR located at lower part of FBT (T601)

Measuring Instrument : Pattern generator / reader: LCG-401

1. Enter to "Aging Mode Screen" by pressing "TEST" key on the jig remote controller once.
2. Press "10" key of the numeric channel keypad to get a horizontal single line screen (Fig.2-2).
3. Adjust SFR located at lower part of FBT (T601) until the horizontal line starts to be slightly brightened.
4. Repeat the process of step 2 and return to the "Adjustment Menu Screen".

PAGE 3

- 3-1. [SUB BRIGHT] Sub-brightness Adjustment / Adjustment Menu Screen: PAGE3-2 (careful with the order)

Input Signal: Color Bar (Stair step)

Measuring Instrument: Pattern generator / reader: LCG-401

- Using the volume keys on the jig remote controller to adjust the scale of the second last from right to be slightly brightened.



2nd from right

Fig. 3-1

3-2. **SUB CONTRAST** Sub-contrast Adjustment / Adjustment Menu Screen: PAGE 3-1

Input Signal: Color Bar (QIW)
croma/OFF

Measuring Instrument: Oscilloscope Pattern generator / reader:

Test Point: S0901 R(R CATHODE)

1. Connect the oscilloscope to S0901 R.
2. Using the volume keys on the jig remote controller adjust the pedestal level and the voltage of 100% white to $105 \pm 2.0V$, according to Fig. 3-2.

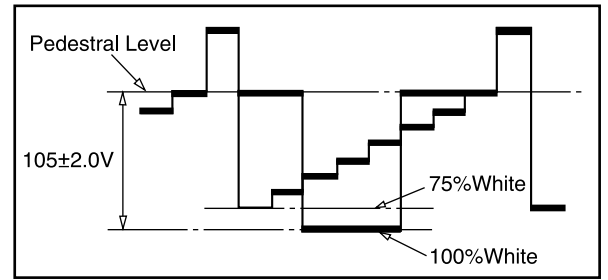

Fig. 3-2

3-3. **SUB TINT** Sub-Tint Adjustment / Adjustment Menu Screen: PAGE 3-3

Input Signal: Color Bar (VIDEO IN)

Measuring Instrument: Oscilloscope / Pattern generator / reader:
LCG4-1

Test Point: CNA704 ③ PIN B

1. Connect the oscilloscope to CNA704 ③ PIN B.
2. Using the volume keys on the jig remote controller, adjust the top excursions of waveform "Magenta" and "Blue" to be linear (Fig. 3-3).

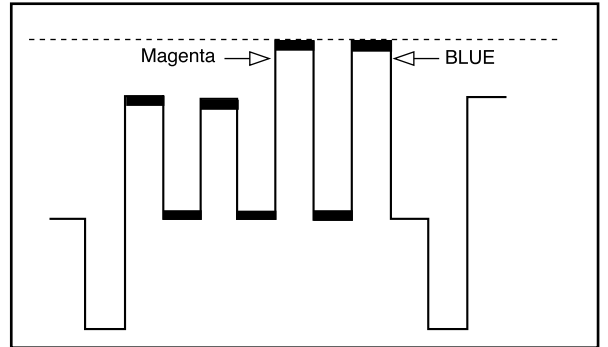

Fig. 3-3

3-4. **SUB COLOR** Sub-color Adjustment / Adjustment Menu Screen: PAGE3-4

Input Signal: Color Bar (VIDEO IN)

Measuring Instrument: Oscilloscope / Pattern generator / reader:
LCG-401

Test Point: CNA704 ③ PIN B

1. Connect the oscilloscope to CNA704 ③ PIN B.
2. Using the volume keys on the jig remote controller, adjust the top excursions of waveform to be linear (Fig. 3-4).

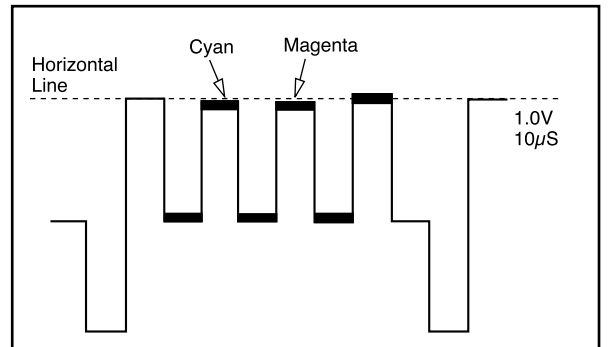

Fig. 3-4

PAGE 4

4. **TV SETTING CHECK** Confirmation of Model Setting / Adjustment Menu Screen: PAGE4-1~4

Each setting is particular to each model. Do not make any changes to these fixed setting.

- Check if the details of the Adjustment Menu Screen are the same as those in Fig. 4. If they were different, readjust them accordingly using the volume keys on the jig remote controller.

3.58 TRAP	0 : ON
BPF	2 : AUTO
H AFC	1 : +1
WPL	0 : OFF

* The details of 3.58 TRAP cannot be controlled.

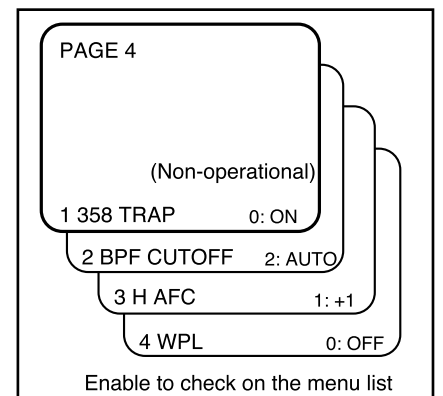

Fig. 4

5-1. **ATT ALIGNMENT** ATT Adjustment / Adjustment Menu Screen: PAGE 5-1

Input Signal: ANT RF-INPUT / Color Bar

Measuring Instrument: Oscilloscope / Pattern generator / reader: LCG-401

Test Point: IC701 ② PIN **TV OUT-L**

1. Connect the oscilloscope to IC701 ② PIN
2. Using the volume keys on the jig remote controller, adjust the value of IC701 ② PIN to $490 \pm 20\text{mVrms}$.

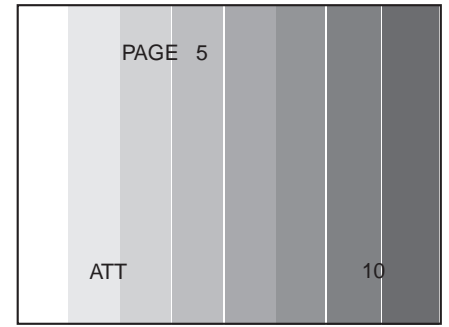

Fig. 5-1

5-2. **SEPARATION ALIGNMENT** Adjustment of Stereo Sound Separation Degree/Adjustment Menu Screen: PAGE 5-2~3

Input Signal: Setting of TV Multiplex Transmission Signaler

Variation	Internal
Internal Variation	400 Hz
Audio	L ch
Channel	2 ch
Video Signal	Color Bar

Multiplex Transmission Signaler RF Output / 2CH

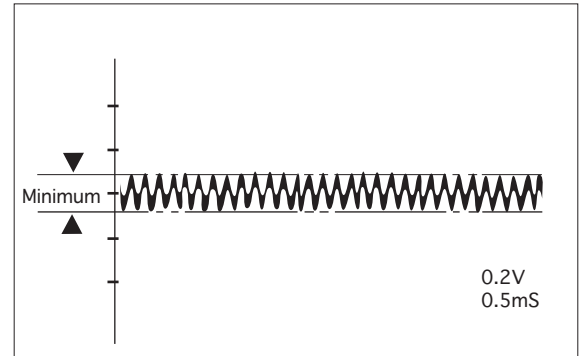

Fig. 5-2

Measuring Instrument: Oscilloscope / TV Multiplex Transmission Signaler / reader: 236A

Test Point: IC701 ① PIN **TV OUT-R**

1. Connect the oscilloscope to IC701 ① PIN
2. Start receiving signals from TV 2CH.
3. PAGE5-3

Using the volume keys on the jig remote controller, adjust the voltage width of IC701 ① PIN waveform to the minimum as in Fig 5-3.

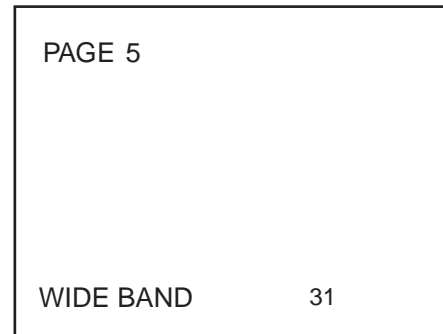

Fig. 5-3

4. Adjust the internal Variation of TV Multiplex Transmission Signaler to 1kHz and perform the same method as in step 3. (Fig 5-4)
5. Repeat the step 3~4 for several times to adjust for the minimum value.

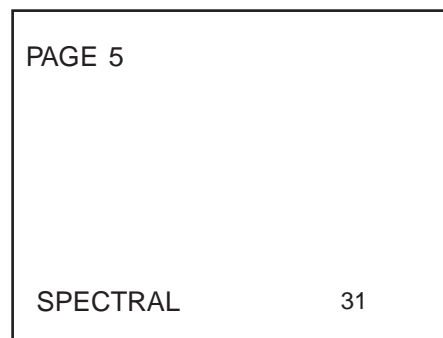

Fig. 5-4

TUNER ADJUSTMENT

If adjustment elements were replaced for repair, conduct the following set of adjustments. And then, further adjustments should be conducted on the Adjustment Menu Screen.

If this set of adjustments was not completed, no further adjustments on the Adjustment Menu Screen can be conducted.

The elements whose circuit condition will be altered depending on repair.

- VCO coil
- SIF coil

6-1. **VCO ADJUSTMENT** VCO (PIF) Adjustment / Video Transfer Frequency Free-Running Adjustment

Input Signal: RF-Color Bar

Input Level: 90dB μ V

BROADCAST CH/fc=45.75MHz

MODE: TUNER

Test Point: IN-PUT / TU101-11PIN **IF**

OUT-PUT / IC301-44PIN **AFT**

Measuring Location: L205/P-IF

Measuring Instrument: Oscilloscope / Pattern generator / reader: LCG401

1. Connect the oscilloscope to IC301-44PIN.
2. Enter the specific level of RF signal to TU101-11PIN, and adjust L205 so that the voltage of IC301-44PIN will be 2.8 ± 0.2 VDC.

6-2. **SIF ADJUSTMENT** Audio IF Variation Adjustment

Input Signal: AM/FM-SG RF OUT/4.5MHz-SIF

MOD OFF

90dB μ V

- The simple way to make adjustment is to receive a normal broadcasting.

MODE: TUNER

Test Point: IN-PUT/IC301-52PIN **SIF**

OUT-PUT/IC301-54PIN **FM DET**

Measuring Location: L201/S-IF

Measuring Instrument: Oscilloscope
Am/FM-Signal Generator

1. Connect the oscilloscope to IC301-54PIN.
2. Enter the specific signal to IC301-52PIN, and adjust L201 so that the voltage of IC301-54PIN will be 4.5 ± 0.2 VDC.

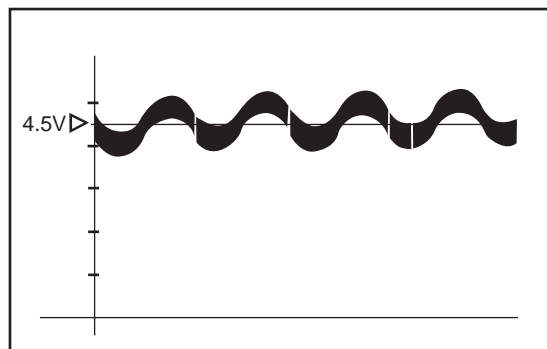

Fig.6-1.