

The Harman/Kardon Model TA600

AM/FM/Stereo FM Solid State Receiver

Technical Manual

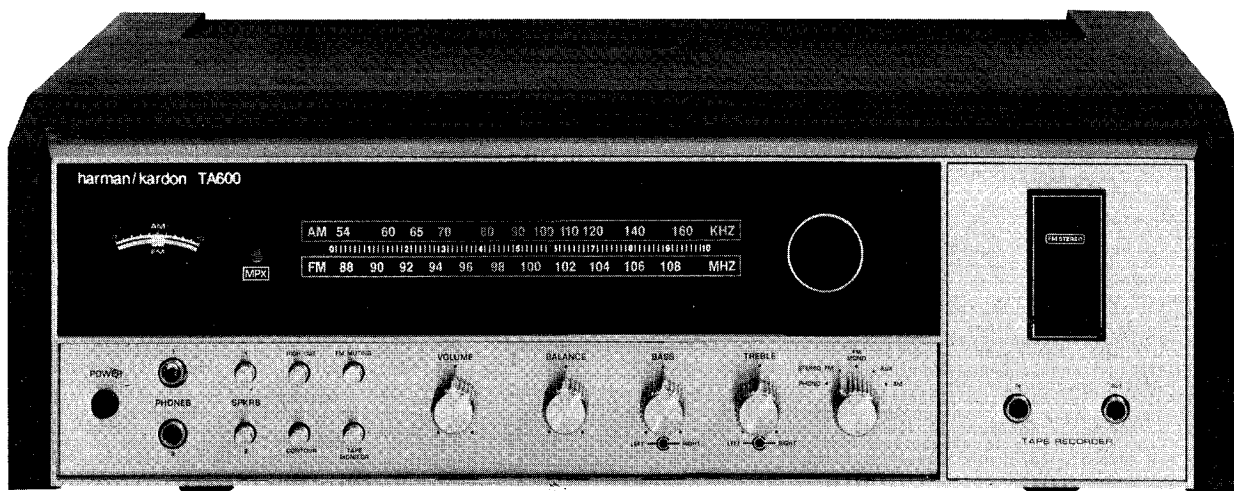

harman/kardon

PRECAUTIONS

1. Always disconnect the chassis from power line when soldering. Turning the power switch OFF is not enough. Power line leakage passing through the heating element may destroy the transistors.
2. Never attempt to do any work on the transistor amplifiers without first disconnecting the AC line cord and waiting until the power supply filter capacitors have discharged.
3. Replacement for output and driver transistors, if necessary, must be made from the same beta group as the original type.
4. If one output transistor burns out (open or short) always remove all the output transistors in that channel and check the bias adjustment, the control and other parts in the network with an ohmmeter before inserting a new transistor. All transistors in one channel will be destroyed if the base biasing circuit is open on the emitter end.
5. When mounting a replacement power transistor, be sure that the bottom of the flange, the mica insulators and the surface of the heat sink are free of foreign matter, for they may cause transistor failure.
6. Silicon grease must be applied between the transistor and the mica insulator, and between the mica insulator and the heat sink for better heat conduction.
7. Fuses must be replaced with size and type indicated. Use of other types can expose components to destructive current levels.

ALIGNMENT PROCEDURES

FM ALIGNMENT PROCEDURE

INSTRUMENTS: FM Signal Generator, Distortion Analyzer, AC Voltmeter

NOTE: Set Function Switch to FM MONO, Signal Generator for 400 or 1000 Hz 100% mod.
Connect Signal Generator to FM 300Ω ANTENNA terminals.
Connect Distortion Analyzer and AI Voltmeter to Tape 1 Left Out

Step	FREQUENCY	SIG. STRENGTH	DIAL SETTING	ADJUST	FOR	AT
1	100 MHz	1000 μ v	—	Tuning knob	Maximum output	TAPE 1 LEFT
2	Same as above	Same as above	—	Dial pointer	100 MHz	FM Dial scale
3	Connect jumper between pin 11 AM/FM board and ground. NOTE: Maintain -3db limiter saturation in steps 4 and 5.					
4	106 MHz	-3db of limiter saturation	Tune for signal at maximum tape output	If slug in front end	Least noise and maximum signal out	TAPE 1 LEFT
5	Same as above	Same as above	Same as above	FM trimmers in front end TCA & TCR	Same as above	Same as above
6	Repeat steps 4 and 5 until no further improvement is noticed.					
7	Disconnect RF input		Quiet point on band	Bottom slug of T103	Center	Tuning meter
8	98 MHz	1000 μ v	Tune for center of tuning meter	Top slug of T103	Least THD	TAPE 1 LEFT
9	Repeat steps 7 and 8 until tuning meter is centered with no signal applied, and there is least THD with meter centered and 1000 μ v input.					
10	Same as above	-3db of limiter saturation	Same as above	If slug in front end	Least THD	TAPE 1 LEFT
11	Remove jumper from pin 11 AM/FM board and ground					
12	Same as above	Same as above	Same as above	VR101	Same as above	Same as above

MPX ALIGNMENT PROCEDURE

INSTRUMENTS: Frequency Counter, AC Voltmeter with Set Level Control, Stereo FM Generator

NOTE: Set Function Switch to Stereo FM

Step	FREQUENCY	SIG. STRENGTH	DIAL SETTING	ADJUST	FOR	AT
1	98 MHz Stereo 9% Pilot	30 μ v 100% mod 9% Pilot	Tune to 98 MHz	VR102 AM/FM	MPX indicator lights at this level	
2	Same as above	1000 μ v	Same as above with Function Switch at FM MONO	L406 MPX	75 kHz on frequency counter (step 2 only)	Pin 16 of U401
3	98 MHz Left channel modulation	Same as above	Tune to 98 MHz	Set 0db on AC Voltmeter		TAPE 1 LEFT
4	Same as above	Same as above	Same as above	VR401	Minimum and record -db	TAPE 1 RIGHT
5	98 MHz right channel modulation	Same as above	Same as above	Set 0db reference on AC VTVM		Same as above
6	Same as above	Same as above	Same as above	VR401	Halfway between current reading and reading in step 4	TAPE 1 LEFT

AM ALIGNMENT PROCEDURE

INSTRUMENTS: SSG, modulated with 400Hz at 30%, V.T.V.M., AM IF Sweep Generator, and Oscilloscope.

NOTE: Set Function Switch to AM.
Connect signal source to a loop placed to radiate signals into AM ANT LOOP STICK.

Step	SIGNAL SOURCE OUTPUT	CONNECT OUTPUT METER TO	DIAL SETTING	ADJUST	ADJUST FOR
1	455kHz of sweep generator	V.T.V.M. & oscilloscope to TAPE OUT	Quiet point near 1600kHz	L101	Maximum and symmetrical pattern on SCOPE
2				T101, input side	
3				T101, output side	
4	Repeat step 1 through 3 for best sensitivity and symmetrical pattern on oscilloscope.				
5	525kHz of S.S.G.	V.T.V.M. to TAPE OUT 1 and distortion meter together with oscilloscope to speaker out	Gang fully closed	L101	Maximum output
6	1700kHz of S.S.G.		Gang fully opened	AM oscillator trimmers TC1 & TC2	
7	Repeat step 5 and 6 for best sensitivity				
8	600kHz of S.S.G.	Same as above	600kHz	AM ANT LOOP STICK	Same as above

STEREO POWER AMP IDLING CURRENT ADJUSTMENT

INSTRUMENT: DC Voltmeter (Set when unit is cold)

NOTE: Set VOLUME control at minimum

Step	DC VOLTMETER CONNECTION	ADJUST	FOR	AT
1	Between TP2 and TP 4	VR1	25mV	Voltmeter
2	Repeat step 1 on other channel	Same as above	Same as above	Same as above

SCHEMATIC DIAGRAM – FRONT END

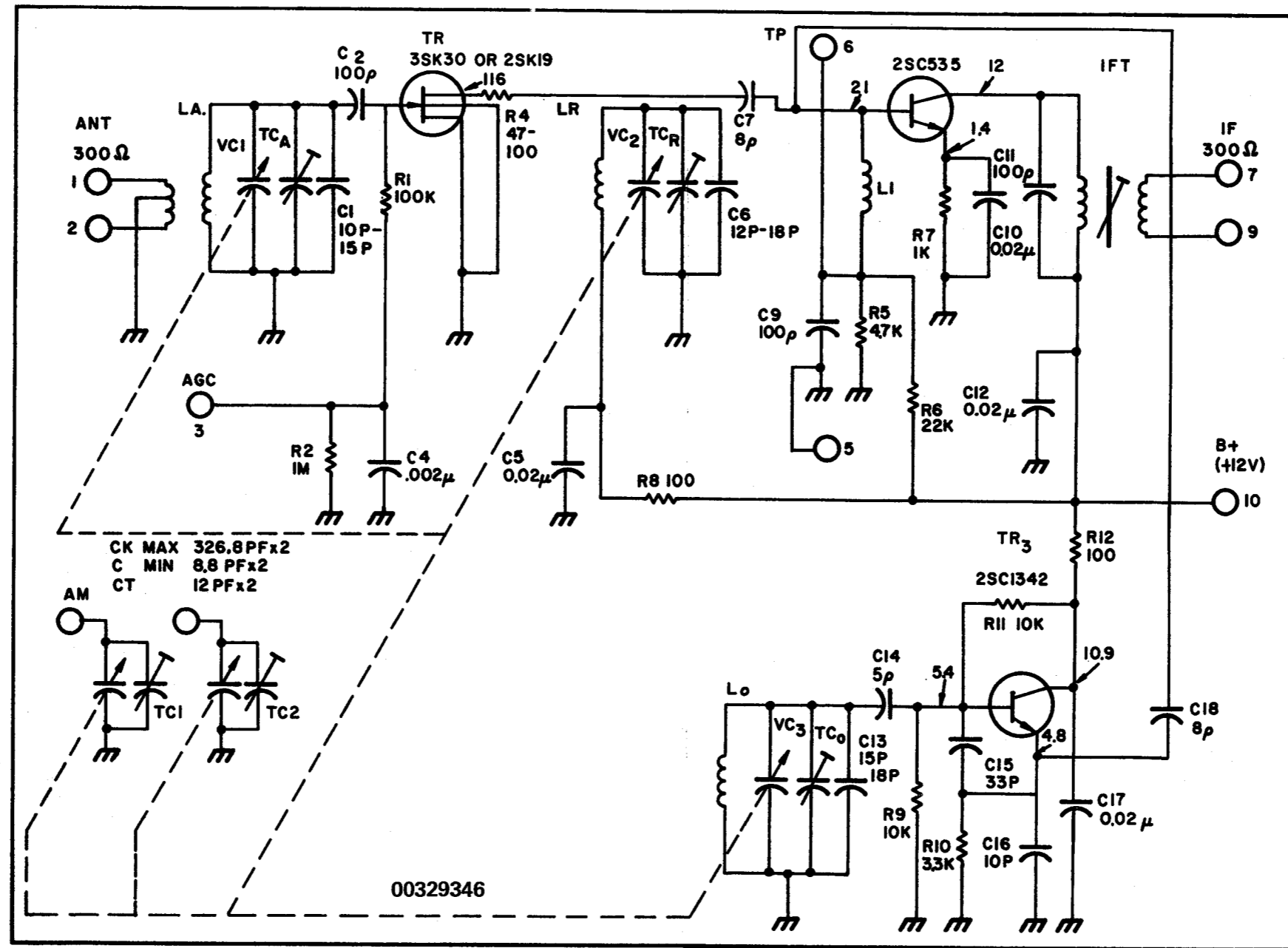

SCHEMATIC DIAGRAM – FRONT END

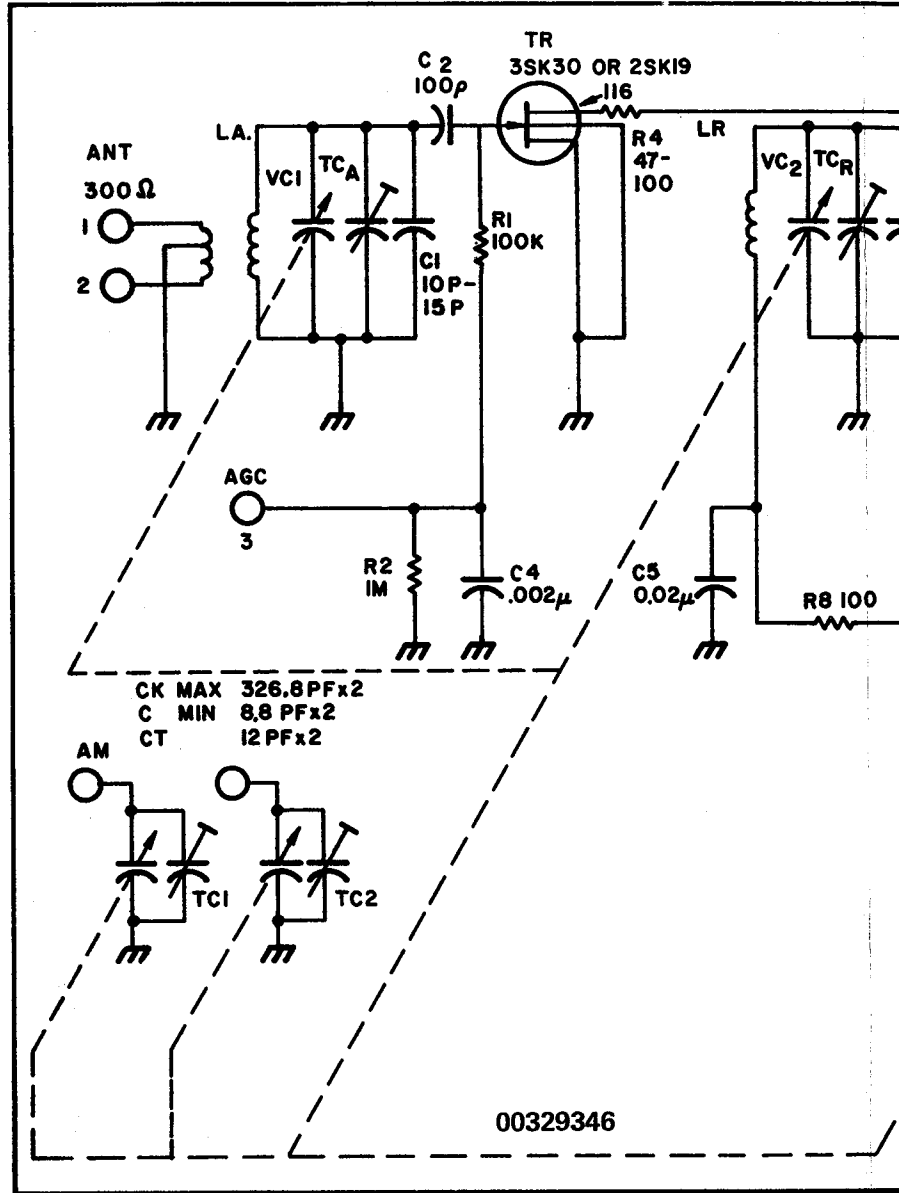

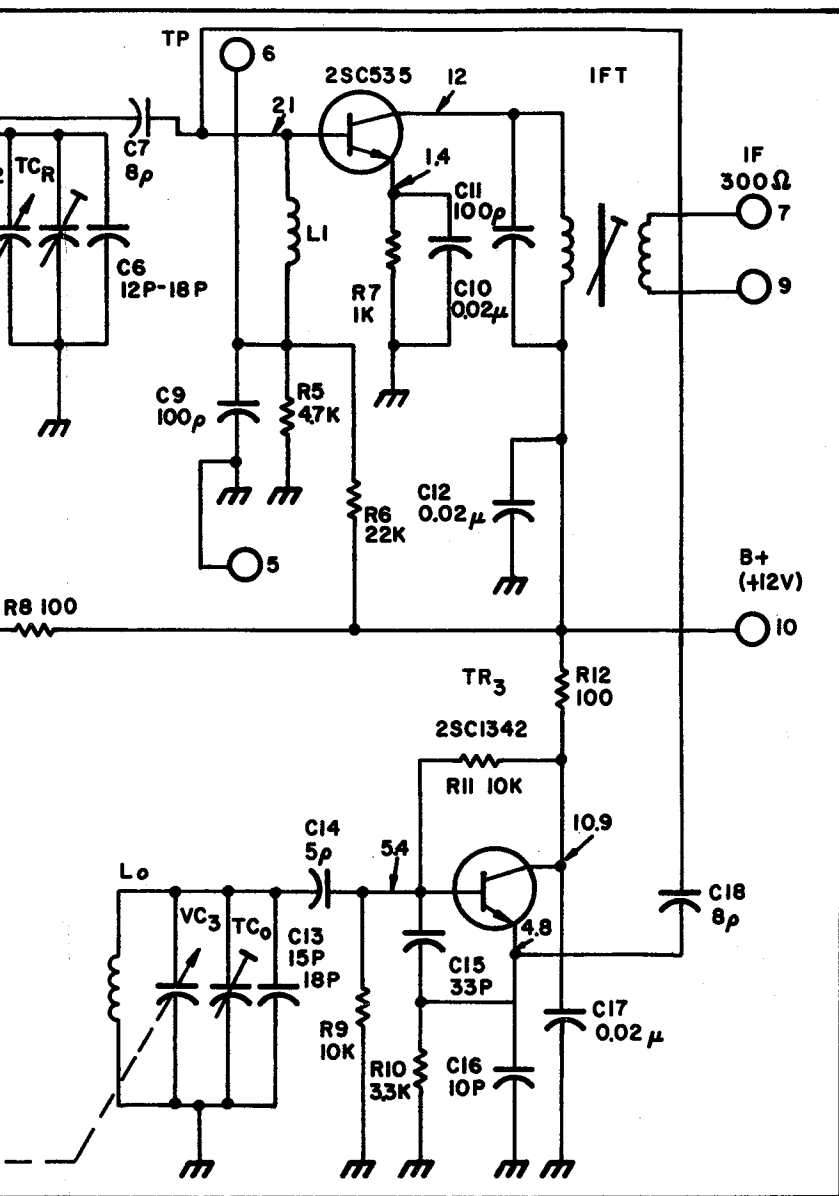

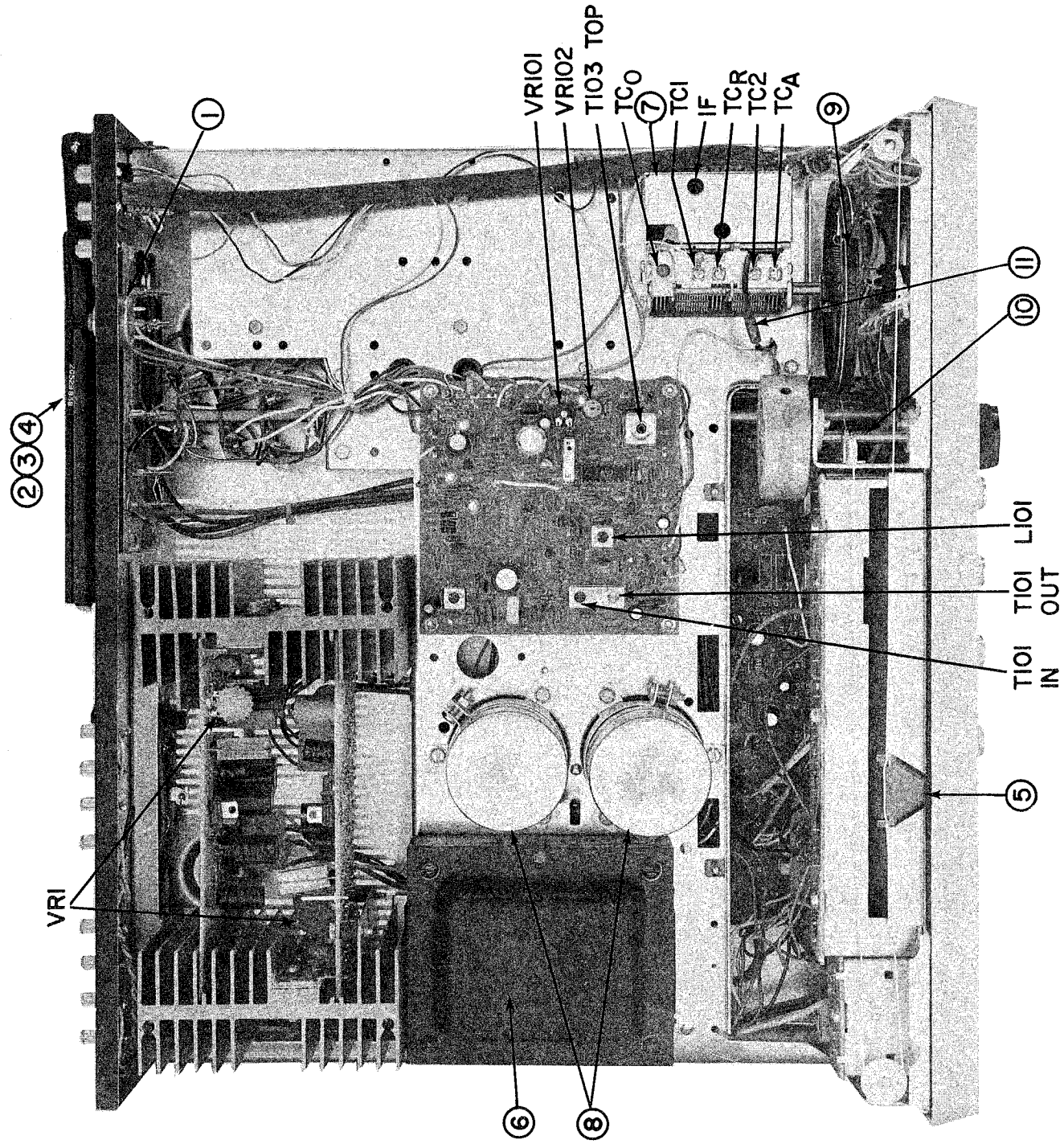

FIG. I
TOP VIEW

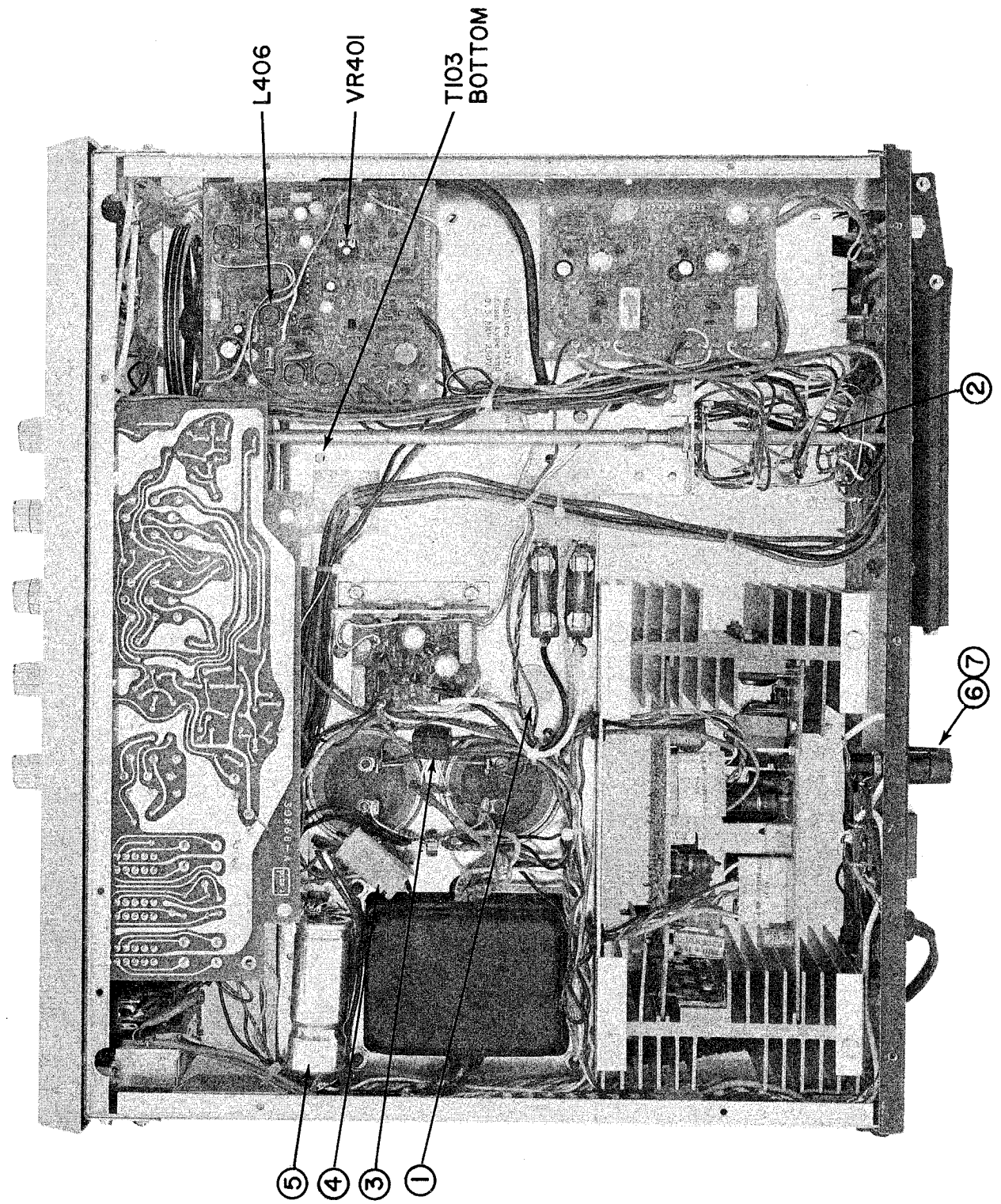

FIG. II
BOTTOM VIEW

ALIGNMENT POINTS

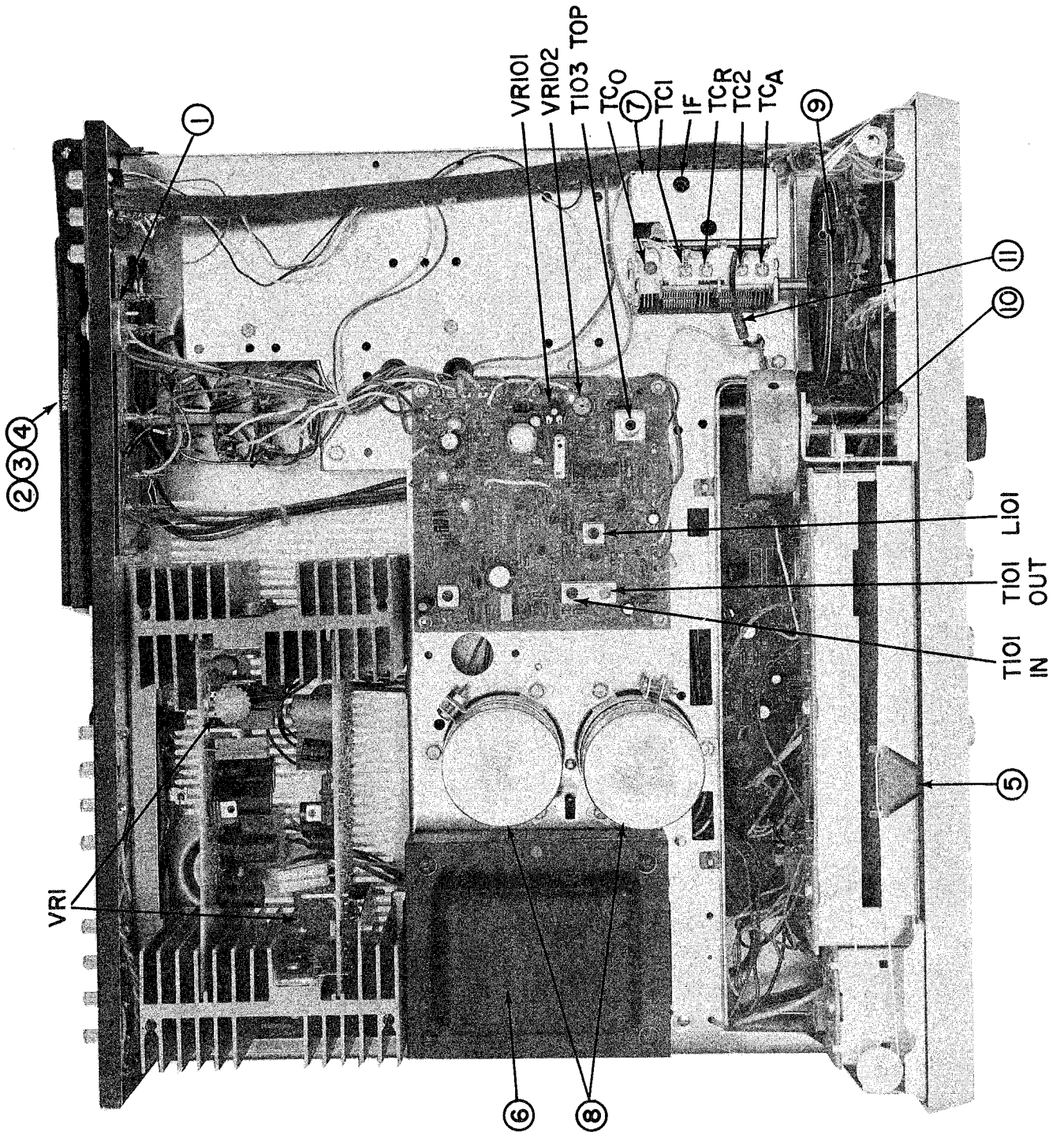

FIG. I
TOP VIEW

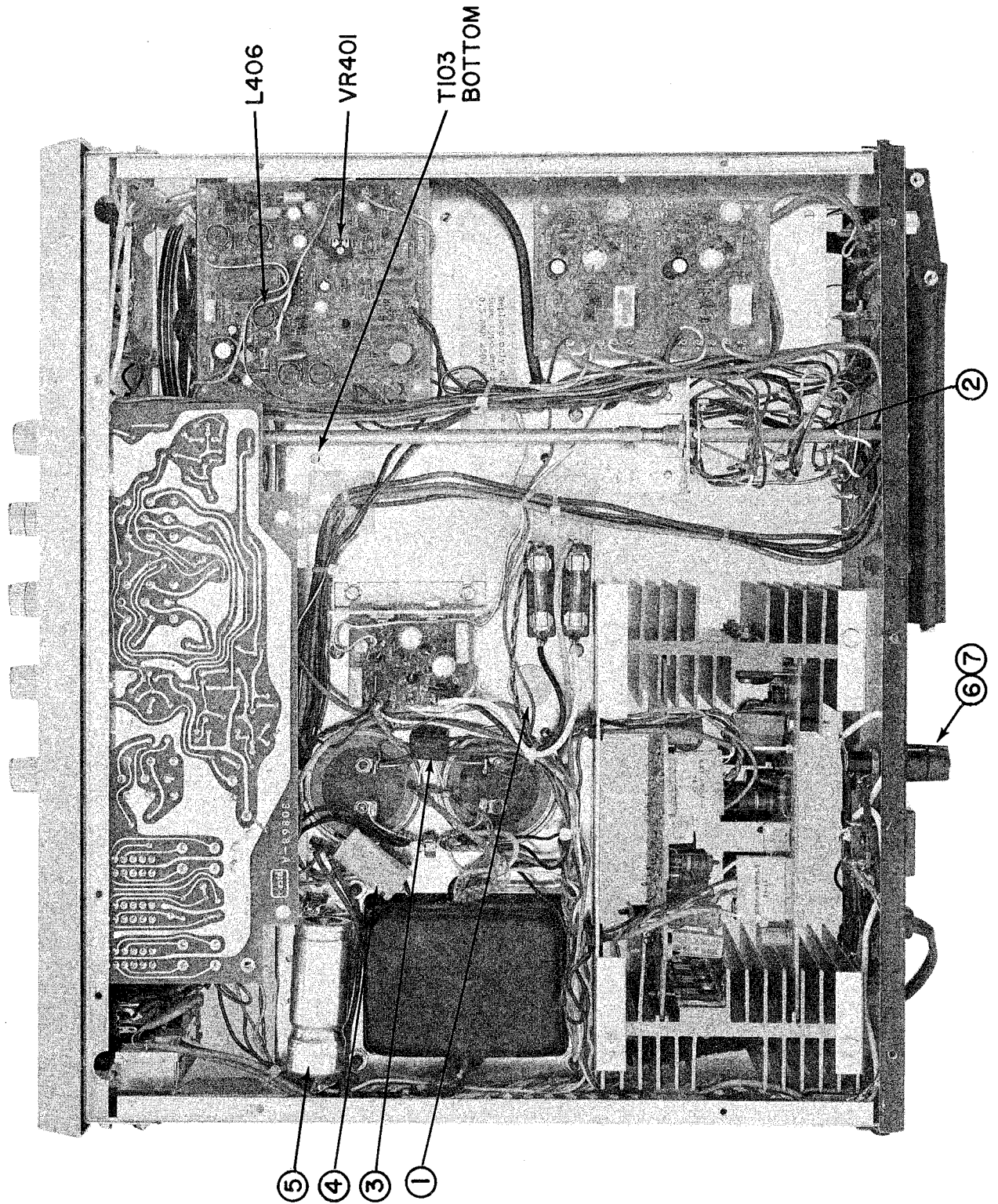
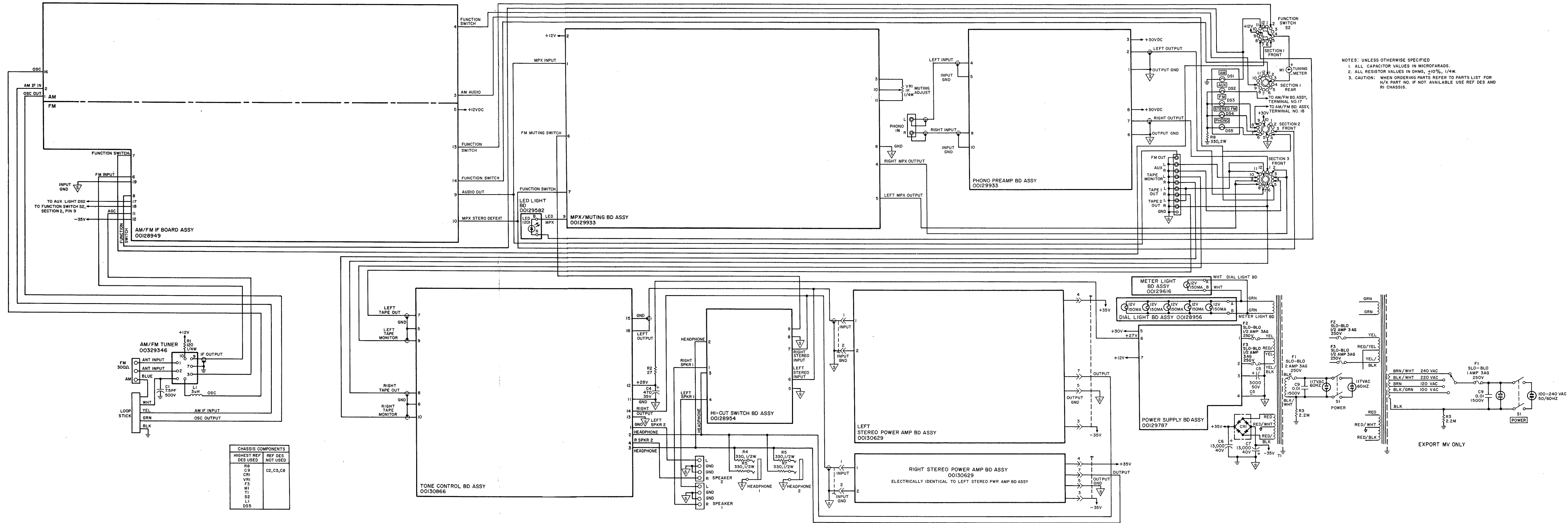
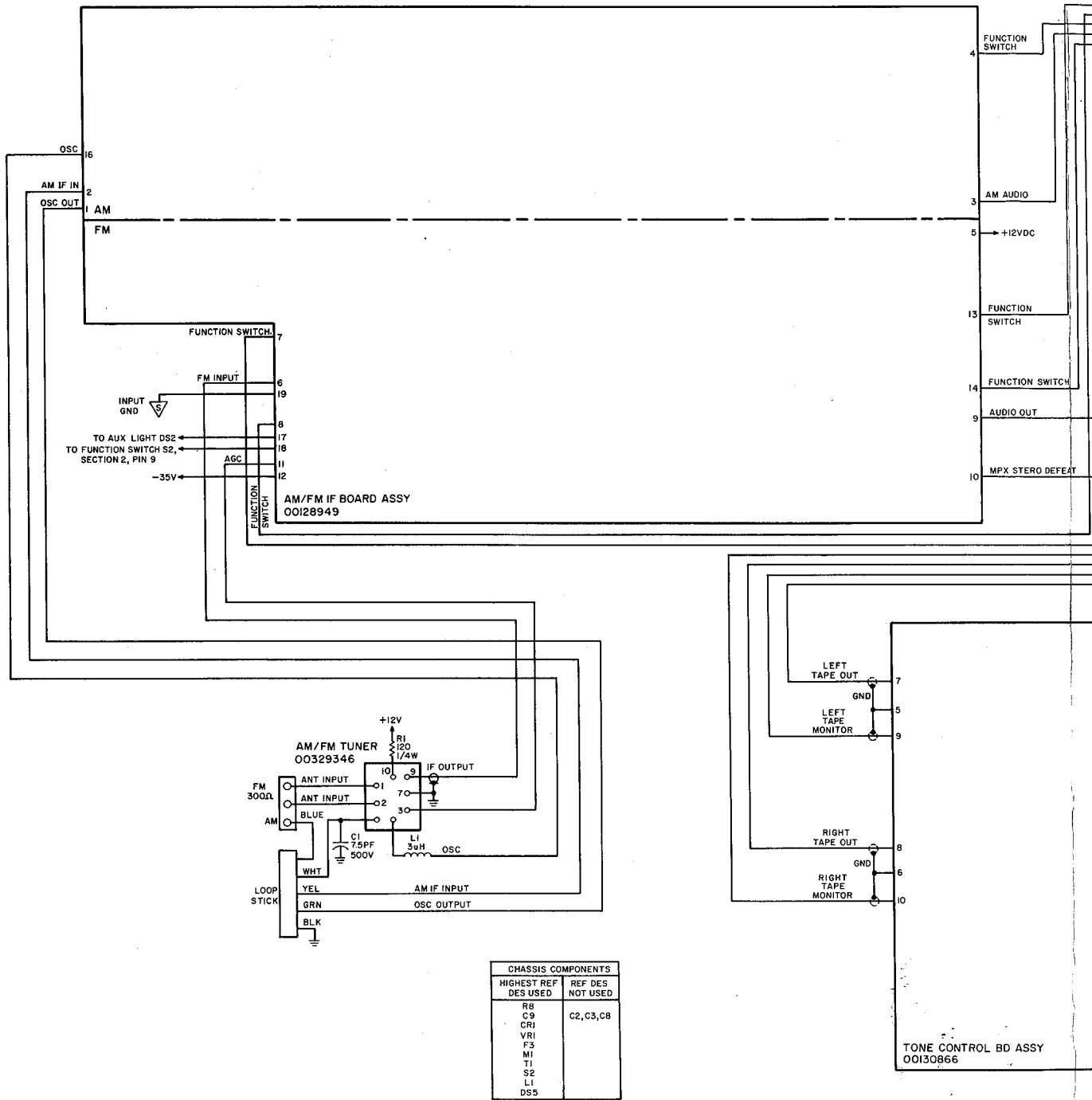

FIG. II
BOTTOM VIEW

**SCHEMATIC DIAGRAM — MODEL TA 600
SYSTEM INTERCONNECTION**



SCHEMATIC DIAGRAM – MODEL TA 600 SYSTEM INTERCONNECTION



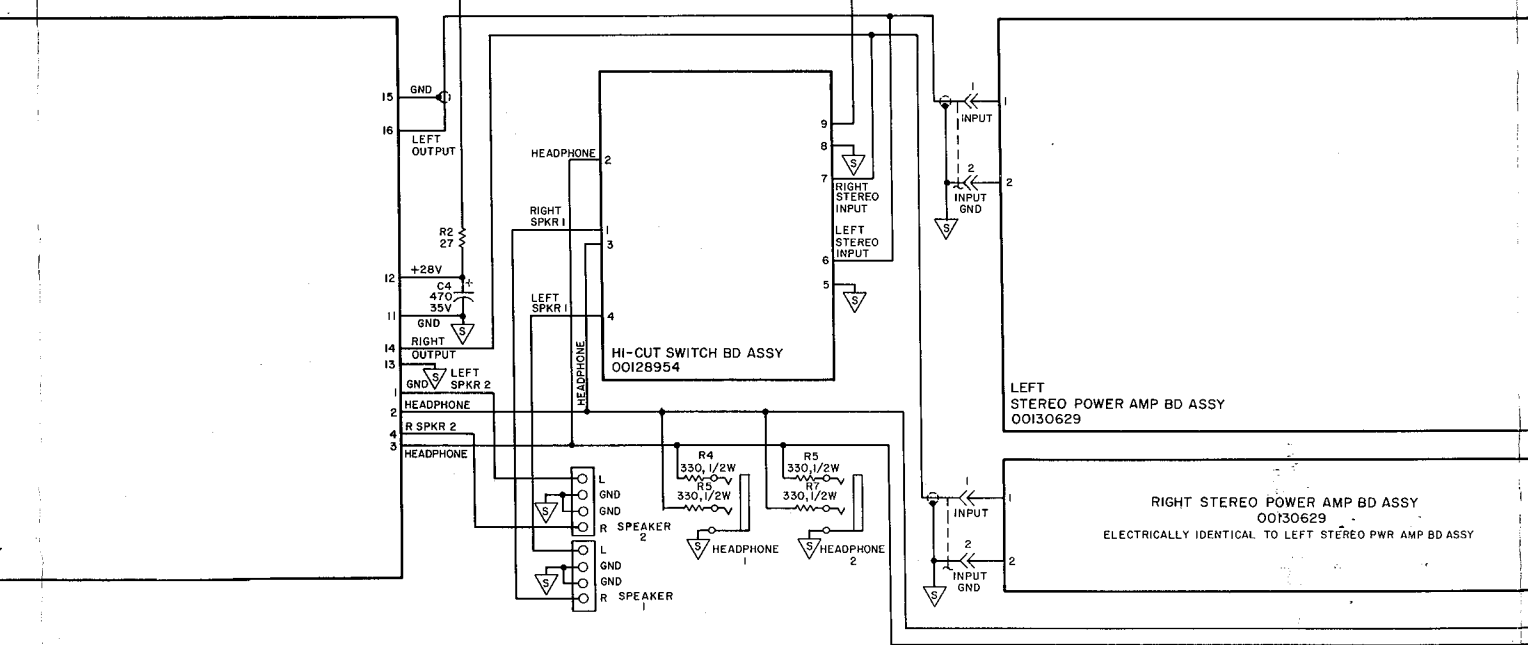
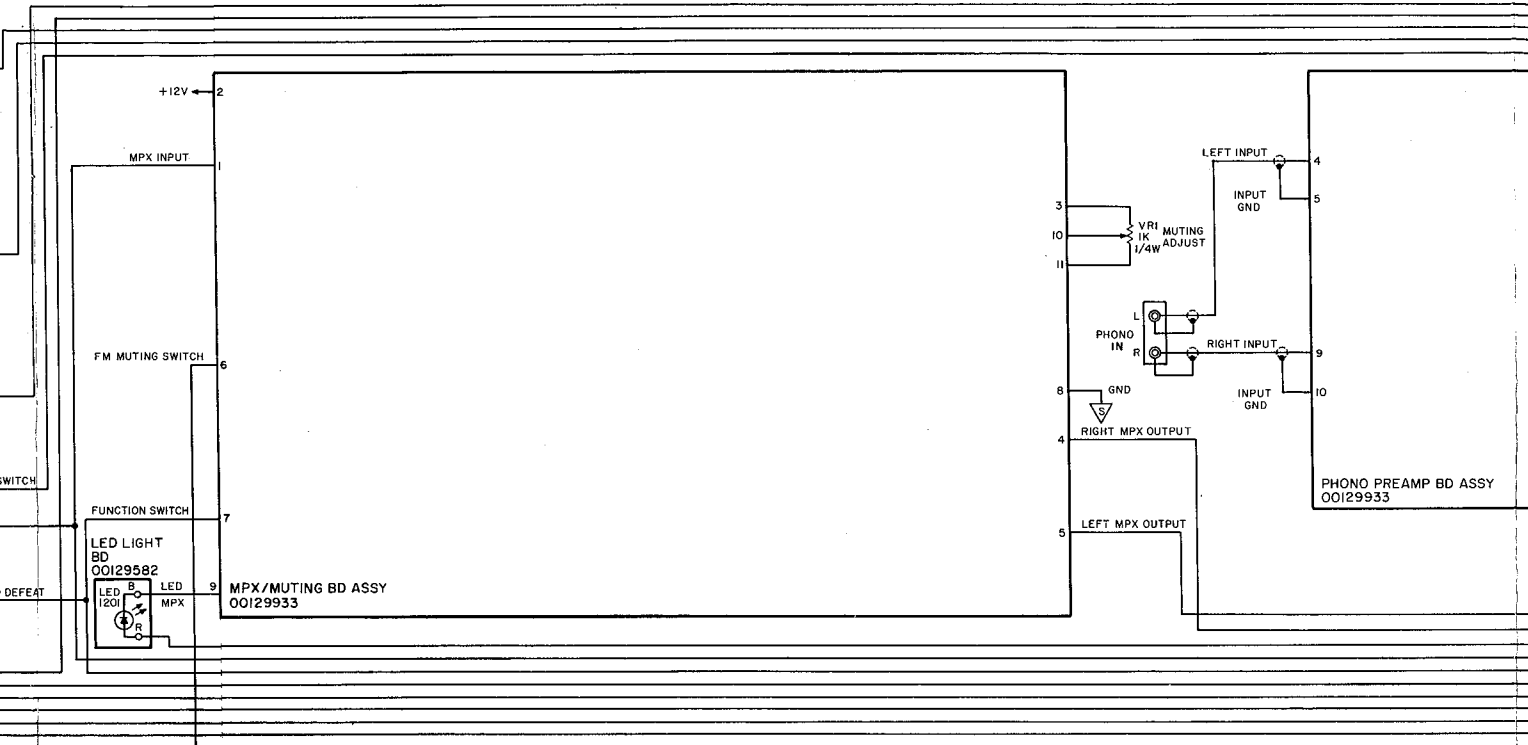

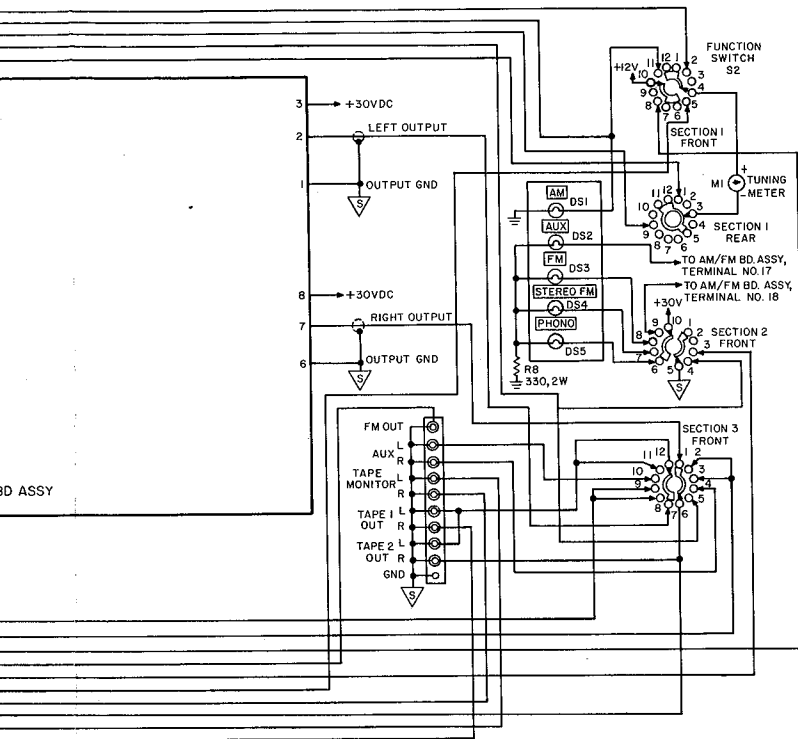

- NOTES: UNLESS OTHERWISE SPECIFIED
1. ALL CAPACITOR VALUES IN MICROFARADS.
 2. ALL RESISTOR VALUES IN OHMS, $\pm 10\%$, 1/4W.
 3. CAUTION: WHEN ORDERING PARTS REFER TO PARTS LIST FOR H/K PART NO. IF NOT AVAILABLE USE REF DES AND RI CHASSIS.

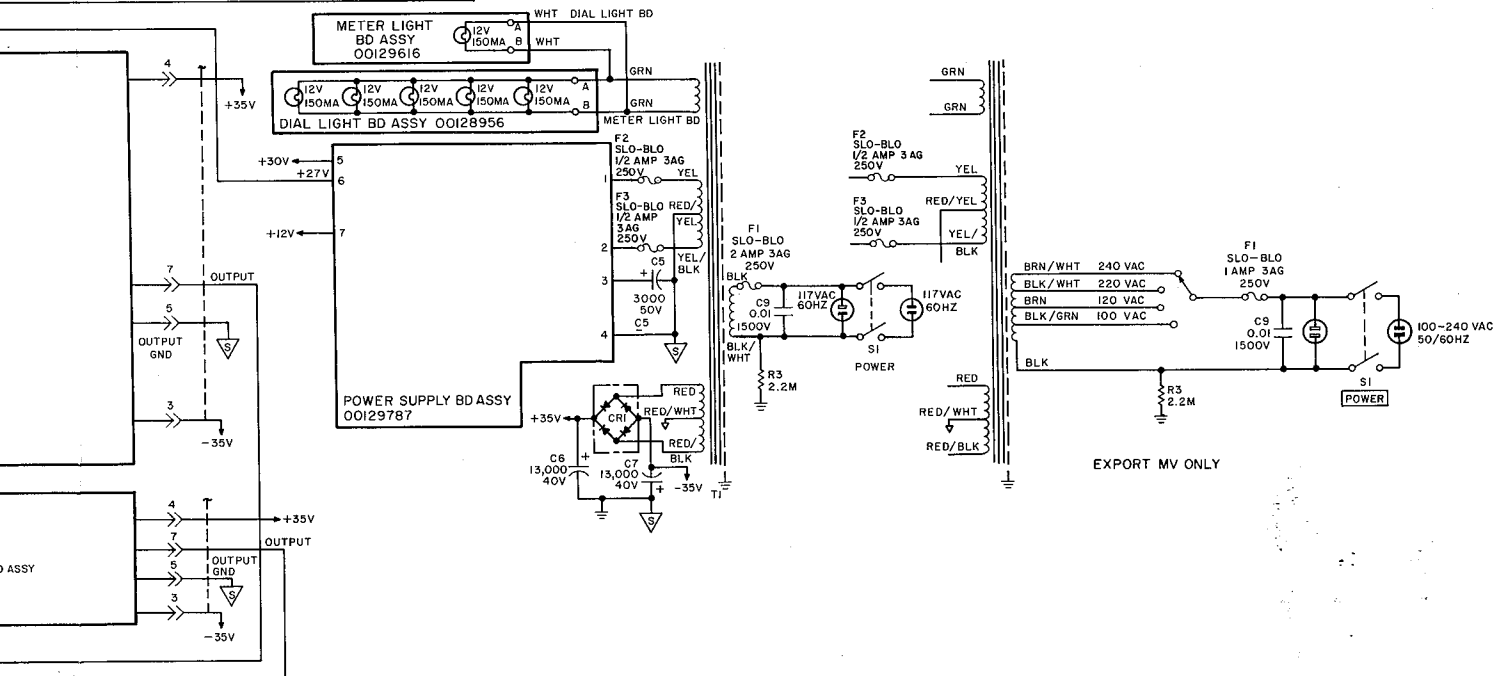

POWER SUPPLY
PC BOARD, SCHEMATIC

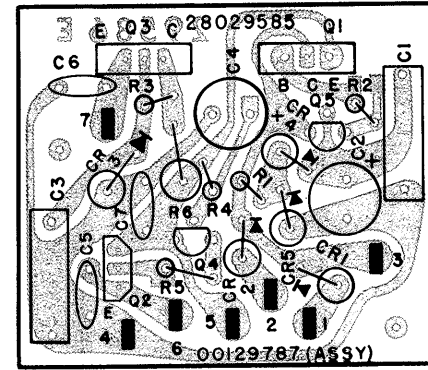

CIRCUIT REF. NO.	H/K PART NO.	DESCRIPTION
	00129787	PC Bd Assy, Power Supply
CAPACITOR, LYTIC		
C2, 4	31819156	50UF, 35V
DIODE		
CR1, 2, 4	41029089*	2 Amp, 200 PIV
CR3	42029340*	Zener, 12.6V, 1W, 10%
CR5	42029676*	Zener, 1N4751, 30V, 1W, 10%
TRANSISTOR		
Q1	43029710*	NPN Pwr Silicon
Q2	43029387*	NPN Pwr Silicon
Q3	43029550*	NPN Pwr Silicon
Q4, 5	43025972*	NPN GP

PHONO PREAMP
PC BOARD, SCHEMATIC

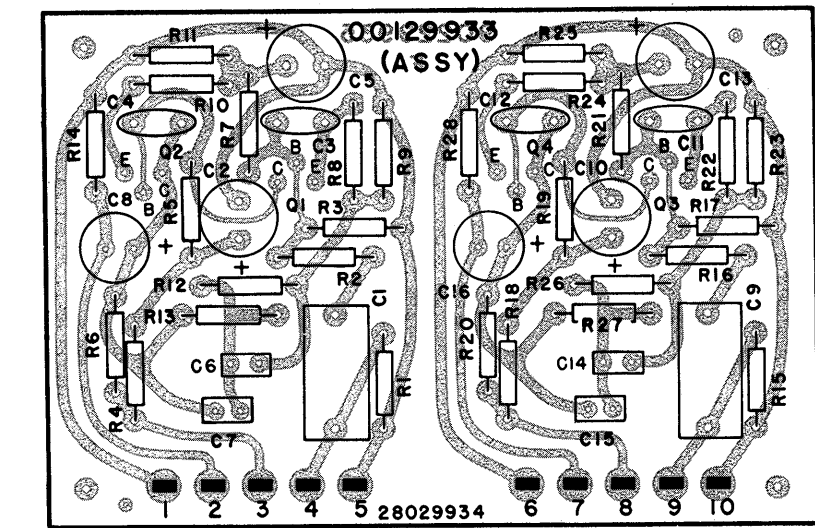

CIRCUIT REF. NO.	H/K PART NO.	DESCRIPTION
	00129933	PC Bd Assy, Phono Preampl
CAPACITOR, LYTIC		
C2, 5, 10, 13	31819180	100UF, 16V
C8, 16	31819165	10UF, 35V
TRANSISTOR		
Q1, 2, 3, 4	43028535*	Hitachi 2SC1344E

- NOTES: UNLESS OTHERWISE SPECIFIED
- ALL CAPACITOR VALUES IN MICROFARADS.
 - ALL RESISTOR VALUES IN OHMS, ±10%, 1/4 W.
 - POWER SUPPLY BD ASSY 00129787
 - MEASUREMENT INFORMATION
METER: WESTON MODEL NO. 4 4 4 4 DVM
MEASUREMENT TOL ±10%
 - UNIT CONTROL AND SWITCH POSITIONS:
SPEAKER SWITCHES 1 & 2—ON (IN) POSITION.
HIGH CUT, FM MUTING, CONTOUR AND TAPE MONITOR SWITCHES—OFF (OUT) POSITION.
VOLUME CONTROL—FULL CCW.
BALANCE, BASS AND TREBLE CONTROL—CENTERED.
FUNCTION SWITCH MODE—PHONO.
 - CAUTION: WHEN ORDERING PARTS REFER TO PARTS LIST FOR H/K PART NO. IF NOT AVAILABLE USE REF DES AND ASSEMBLY USED ON. IE R1 POWER SUPPLY BOARD 00129787

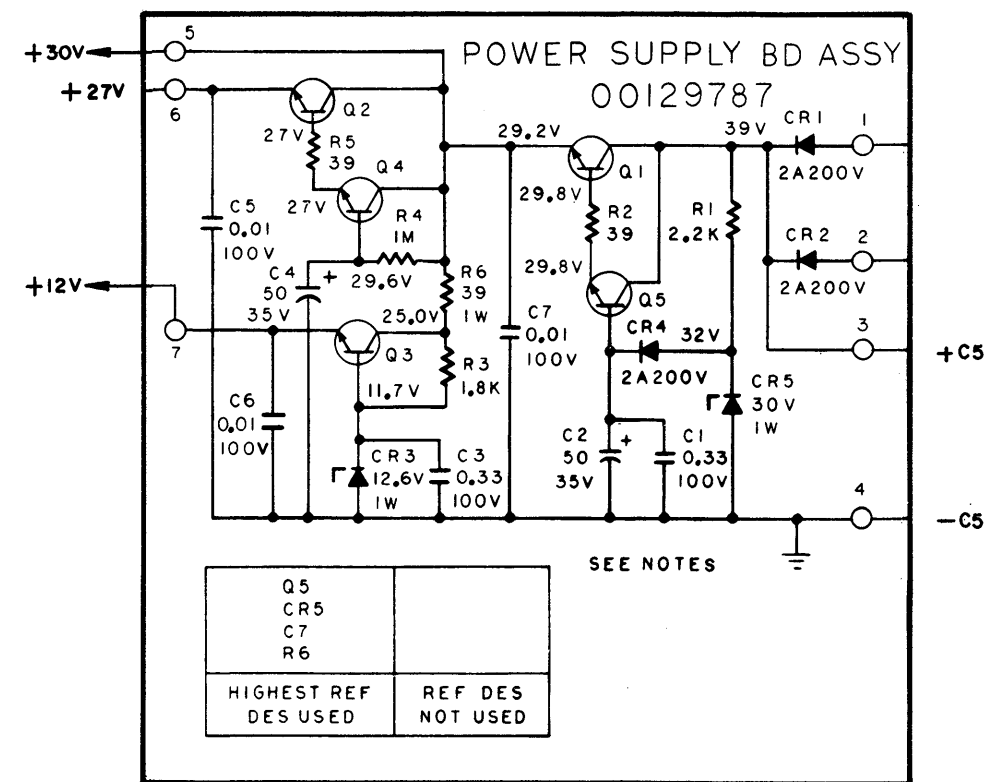

**POWER SUPPLY
PC BOARD, SCHEMATIC**

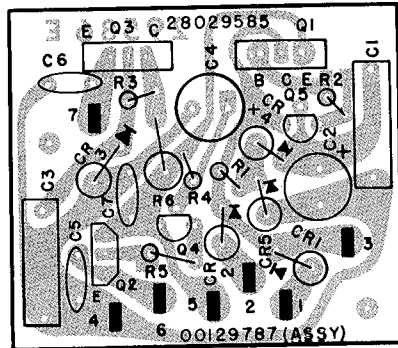

CIRCUIT REF. NO.	H/K PART NO.	DESCRIPTION
	00129787	PC Bd Assy, Power Supply
CAPACITOR, LYTIC		
C2, 4	31819156	50UF, 35V
DIODE		
CR1, 2, 4	41029089*	2 Amp, 200 PIV
CR3	42029340*	Zener, 12.6V, 1W, 10%
CR5	42029676*	Zener, 1N4751, 30V, 1W, 10%
TRANSISTOR		
Q1	43029710*	NPN Pwr Silicon
Q2	43029387*	NPN Pwr Silicon
Q3	43029550*	NPN Pwr Silicon
Q4, 5	43025972*	NPN GP

NOTES: UNLESS OTHERWISE SPECIFIED

1. ALL CAPACITOR VALUES IN MICROFARADS.
2. ALL RESISTOR VALUES IN OHMS, $\pm 10\%$, 1/4 W.
3. POWER SUPPLY BD ASSY 00129787
 - A. MEASUREMENT INFORMATION
 - METER: WESTON MODEL NO. 4 4 4 4 DVM
 - MEASUREMENT TOL $\pm 10\%$
 - B. UNIT CONTROL AND SWITCH POSITIONS:
 - SPEAKER SWITCHES 1 & 2—ON (IN) POSITION.
 - HIGH CUT, FM MUTING, CONTOUR AND TAPE MONITOR SWITCHES—OFF (OUT) POSITION.
 - VOLUME CONTROL—FULL CCW.
 - BALANCE, BASS AND TREBLE CONTROL—CENTERED.
 - FUNCTION SWITCH MODE—PHONO.
4. CAUTION: WHEN ORDERING PARTS REFER TO PARTS LIST FOR H/K PART NO. IF NOT AVAILABLE USE REF DES AND ASSEMBLY USED ON. IE R1 POWER SUPPLY BOARD 00129787

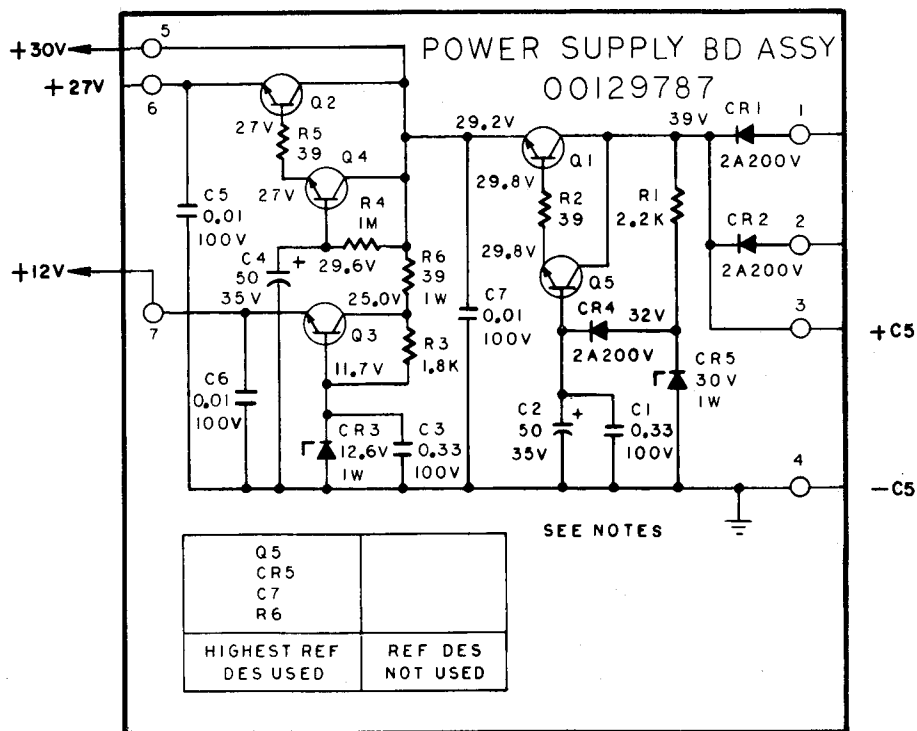

PHONO PREAMP
PC BOARD, SCHEMATIC

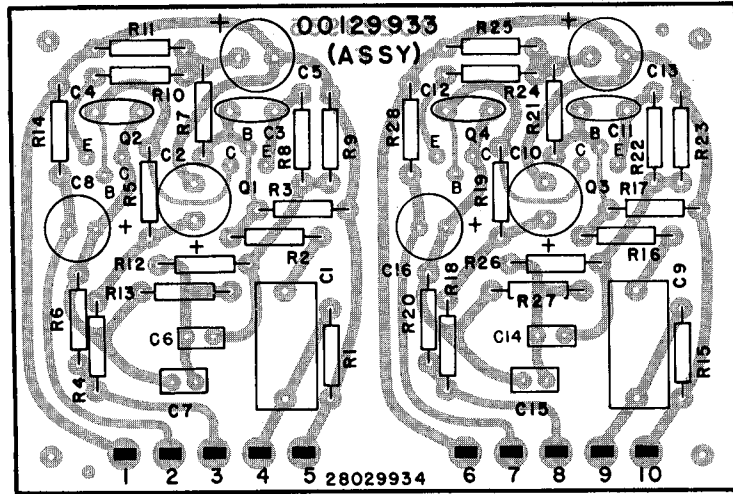

CIRCUIT REF. NO.	H/K PART NO.	DESCRIPTION
	00129933	PC Bd Assy, Phono Preamp
CAPACITOR, LYTIC		
C2, 5, 10, 13	31819180	100UF, 16V
C8, 16	31819165	10UF, 35V
TRANSISTOR		
Q1, 2, 3, 4	43028535*	Hitachi 2SC1344E

NOTES: UNLESS OTHERWISE SPECIFIED

1. ALL CAPACITOR VALUES IN MICROFARADS
2. ALL RESISTOR VALUES IN OHMS, $\pm 10\%$, 1/4 W
3. CAUTION: WHEN ORDERING PARTS REFER TO PARTS LIST FOR H/K PART NO. IF NOT AVAILABLE USE REF DES AND ASSEMBLY USED ON. IE RI PHONO PREAMP BOARD 00129933

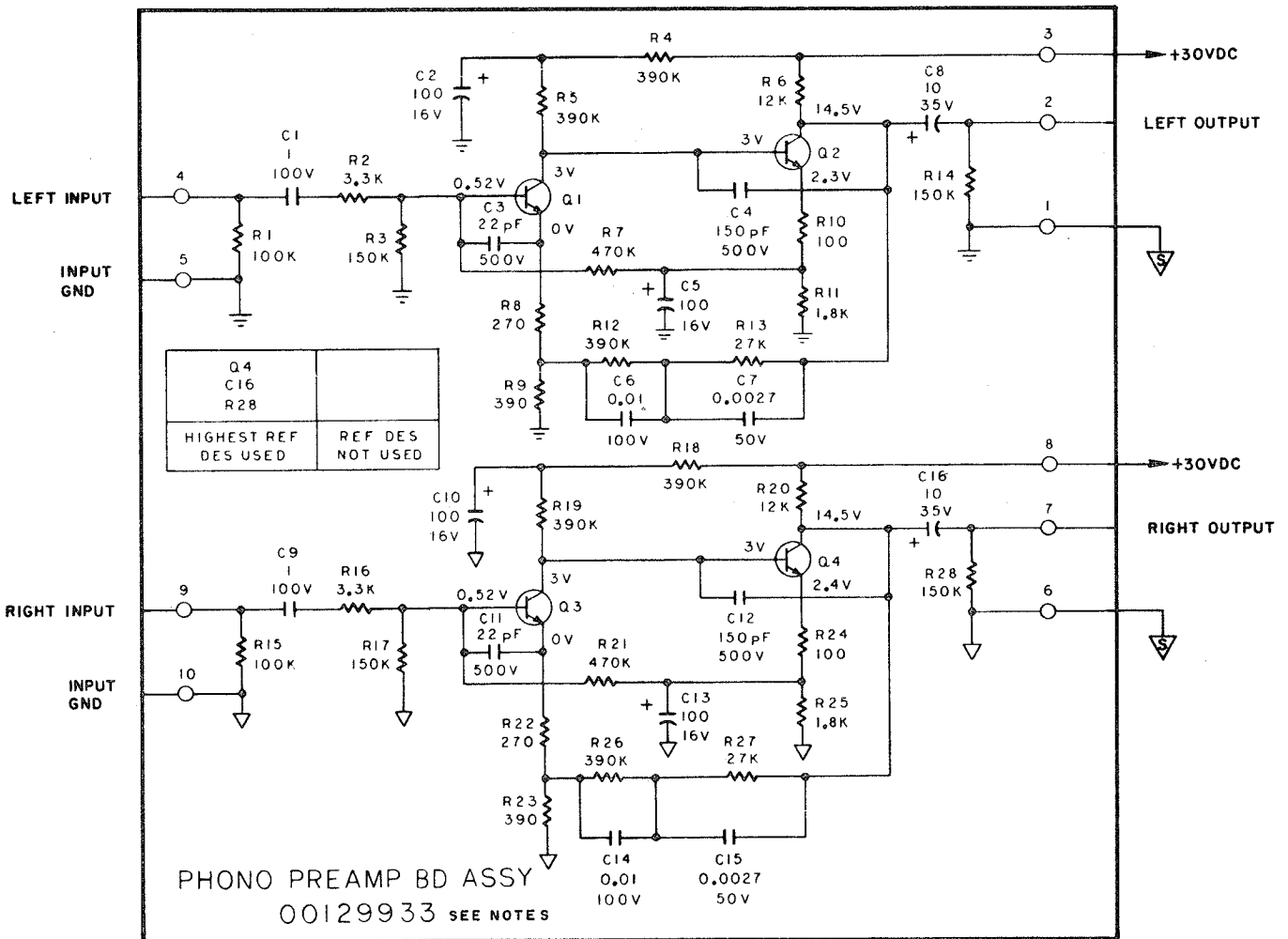

HI-CUT SWITCH BD
PC BOARD, SCHEMATIC

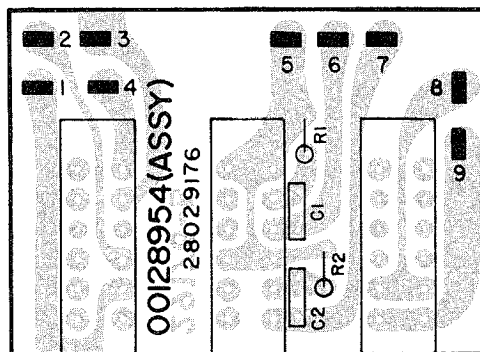

CIRCUIT REF. NO.	H/K PART NO.	DESCRIPTION
	00128954	PC Bd Assy. Hi Cut, FM Muting, Spkr 1 Switch
SWITCH		
S1	25028939	Pushbutton, 4PDT

- NOTES: UNLESS OTHERWISE SPECIFIED
1. ALL CAPACITOR VALUES IN MICROFARADS
 2. ALL RESISTOR VALUES IN MICROFARADS
 3. CAUTION: WHEN ORDERING PARTS REFER TO PARTS LIST FOR H/K PART NO. IF NOT AVAILABLE USE REF DES AND ASSEMBLY USED ON. IE RI HI CUT SWITCH BOARD 00128954

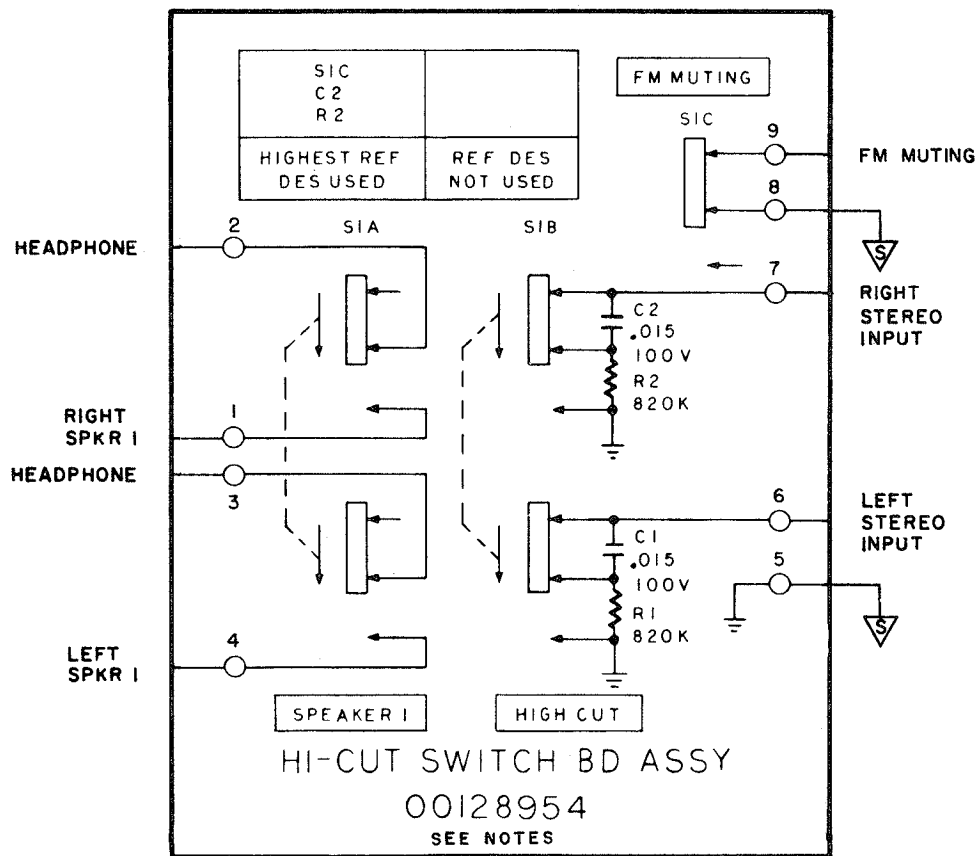

AM/FM IF
PC BOARD, SCHEMATIC

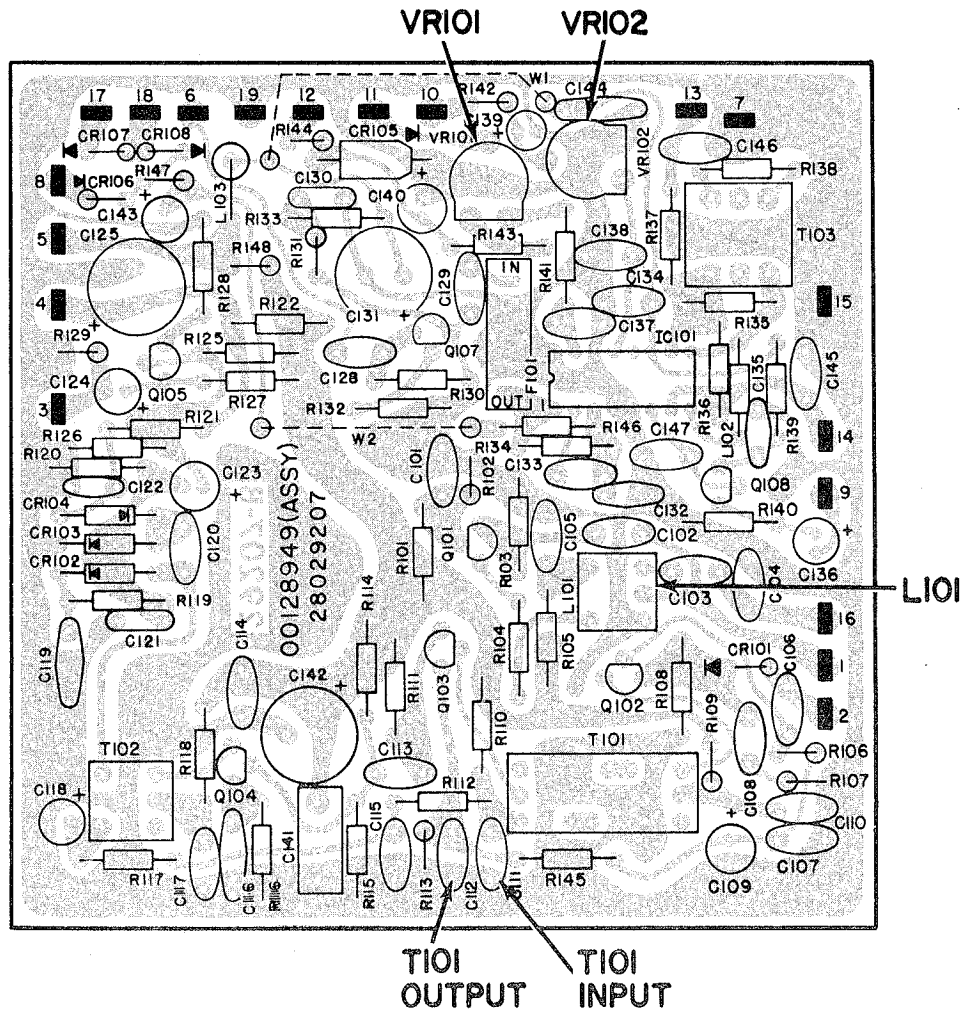

CIRCUIT REF. NO.	H/K PART NO.	DESCRIPTION	CIRCUIT REF. NO.	H/K PART NO.	DESCRIPTION
	00128949	PC Bd Assy. AM/FM IF			
CAPACITOR, LYTIC			TRANSISTOR		
C109, 118	31819155	50UF, 10V	Q101-105, 108	43025972*	NPN GP
C123, 124, 143	31819176	10UF, 25V	Q107	43029701*	NPN RF
C125	31819185	470UF, 10V	INDUCTOR		
C131	31818792	100UF, 35V	L101	12028753	Oscillator
C136, 140	31819178	22UF, 16V	L102	12029342	22UH, 1/4W, ±5%
C139	31819157	1UF, 50V	L103	12029678	3.3UH
C142	31827096	250UF, 16V	T101	12028754	Filter, IF
POTENTIOMETER			T102	12028755	Detector
VR101	21729324	10K PIHER PT10	F101	12029386	Filter, Ceramic, Murata SFW 10.7MA
VR102	21729331	50K PIHER PT10	TRANSFORMER		
DIODE			T103	11029332	Quadrature FM Detect
CR101 - 104	41529814*	1N541	INTEGRATED CIRCUIT		
CR105	42029340*	Zener 12.6V, ±10%	IC101	43129341*	CA3089
CR106 - 108	41629338*	1N914			

- NOTES: UNLESS OTHERWISE SPECIFIED
1. ALL CAPACITOR VALUES IN MICROFARADS
 2. ALL RESISTOR VALUES IN OHMS, $\pm 10\%$, 1/4 W
 3. CAUTION: WHEN ORDERING PARTS REFER TO PARTS LIST FOR H/K PART NO. IF NOT AVAILABLE USE REF DES AND ASSEMBLY USED ON. IE RI AM/FM BOARD 00128949

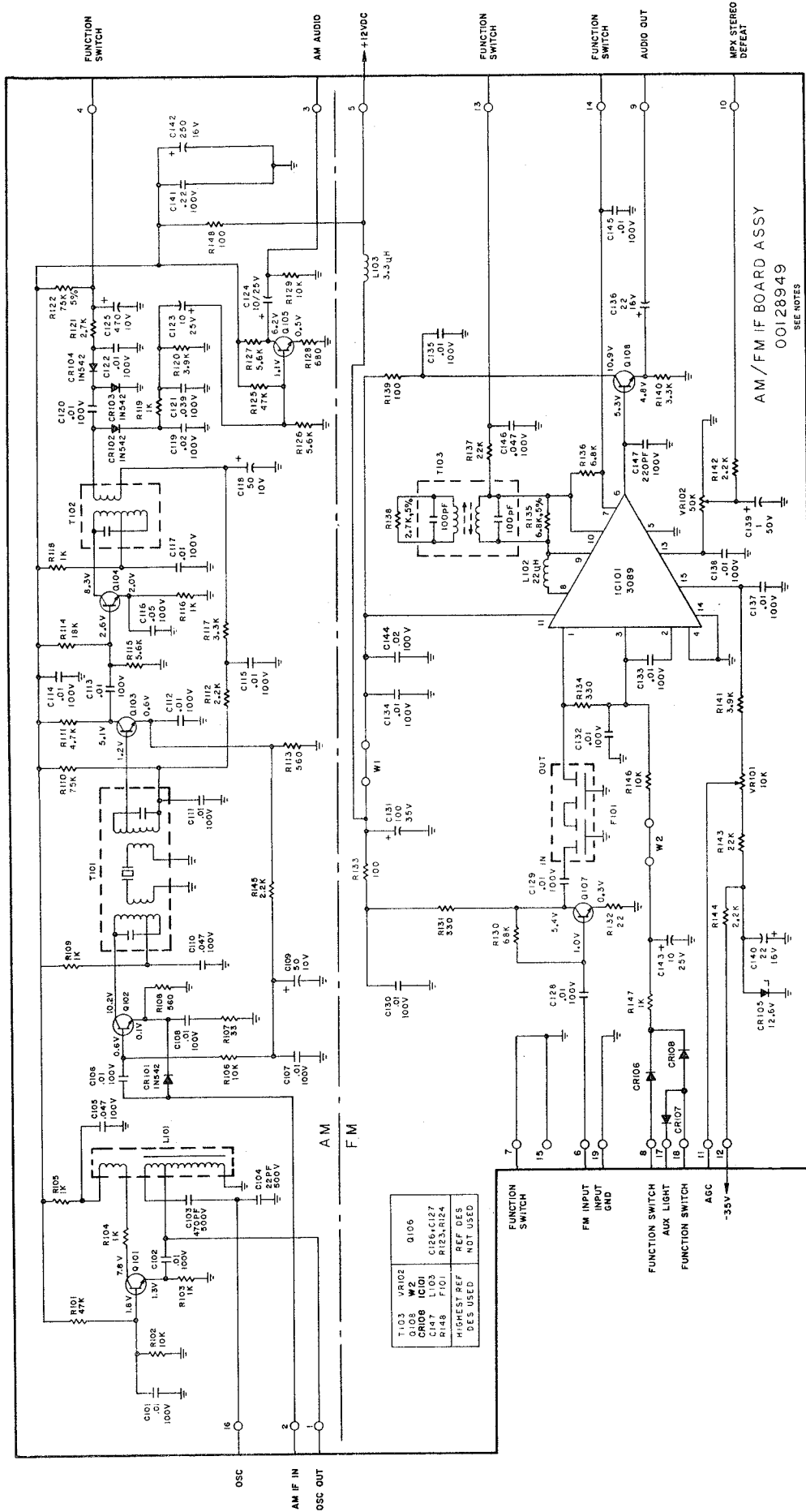

T103	VR102	0106
C108	W2	
C109	L103	C126-C127
CR107	L105	R123-R124
R148	F101	REF DES
HIGHEST REF		NOT USED
DES USED		

STEREO POWER AMP BOARD, LEFT & RIGHT
PC BOARD, SCHEMATIC

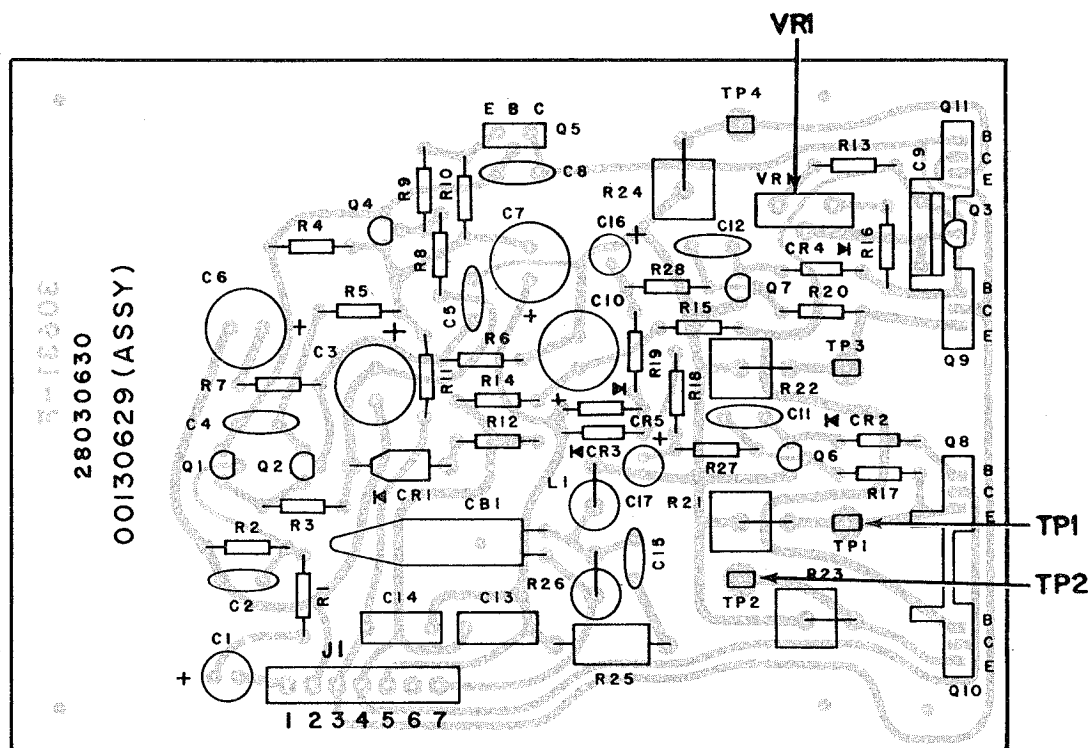

CIRCUIT REF. NO.	H/K PART NO.	DESCRIPTION
	00130629	PC Bd Assy. Stereo Pwr Amp
CAPACITOR, LYTIC		
C1	31819148	10UF, 50V
C3, 7, 10	31830565	50UF, 50V
C6	31819185	470UF, 10V
C16, 17	31819165	10UF, 35V
RESISTOR		
R21, 22, 23, 24	36711071	1 Ohm, 5W, $\pm 10\%$, Wirewound
VR1	21629833	500 Ohm, $\pm 20\%$ Variable, PIHER PT15 YB
DIODE		
CR1	41029089*	2 Amp, 200 PIV
CR2, 4	41629338*	1N914
CR3, 5	41529814*	1N541
TRANSISTOR		
Q1, 2, 7	43027722*	PNP GP
Q3	43029832*	MPS-A13
Q4, 6	43025972*	NPN GP
Q5	43029387*	NPN Silicon Power Driver
Q8, 10	43029037*	NPN Power Darlington
Q9, 11	43029038*	PNP Power Darlington
INDUCTOR		
L1	12029551	Wound on 10 Ohm, 1W Resistor
CIRCUIT BREAKER		
CB1	45524399	Sylvania MB316

NOTES: UNLESS OTHERWISE SPECIFIED

1. ALL CAPACITOR VALUES IN MICROFARADS.
2. ALL RESISTOR VALUES IN OHMS, $\pm 10\%$, 1/4 W.
3. SET VR1, 500 OHM POT, FOR 25mVDC BETWEEN TP1 & TP4
4. MEASUREMENT INFORMATION
 SPEAKER SWITCHES 1 & 2—ON (IN) POSITION.
 HIGH CUT, FM MUTING, CONTOUR AND TAPE MONITOR SWITCHES—OFF (OUT) POSITION.
 VOLUME CONTROL—FULL CCW.
 BALANCE, BASS AND TREBLE CONTROL—CENTERED.
 FUNCTION SWITCH MODE—PHONO.
5. CAUTION: WHEN ORDERING PARTS REFER TO PARTS LIST FOR H/K PART NO. IF NOT AVAILABLE USE REF DES AND ASSEMBLY USED ON. IE RI STEREO POWER AMP BOARD

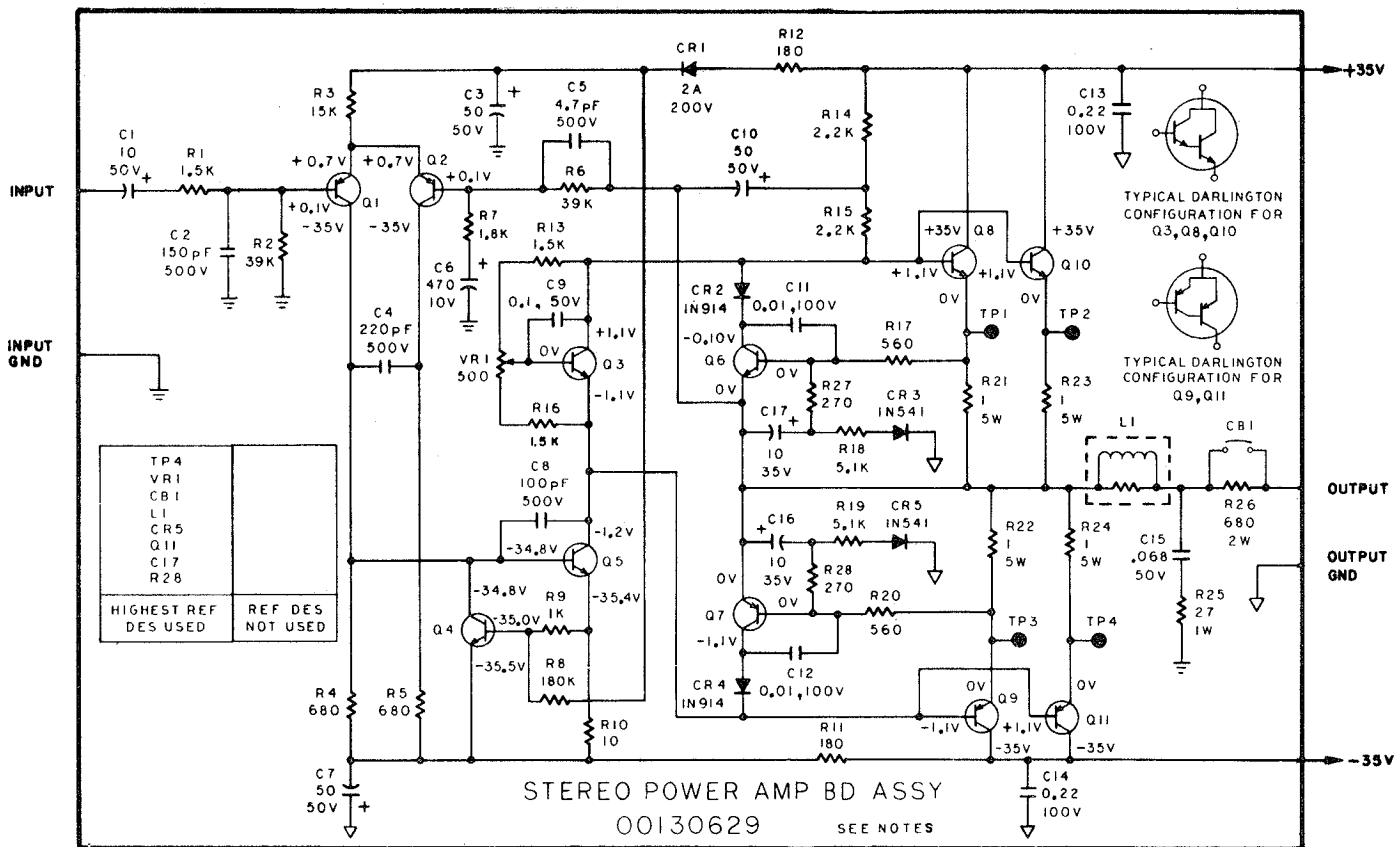

VOLUME/MODE/SWITCH/TONE CONTROL
PC BOARD, SCHEMATIC

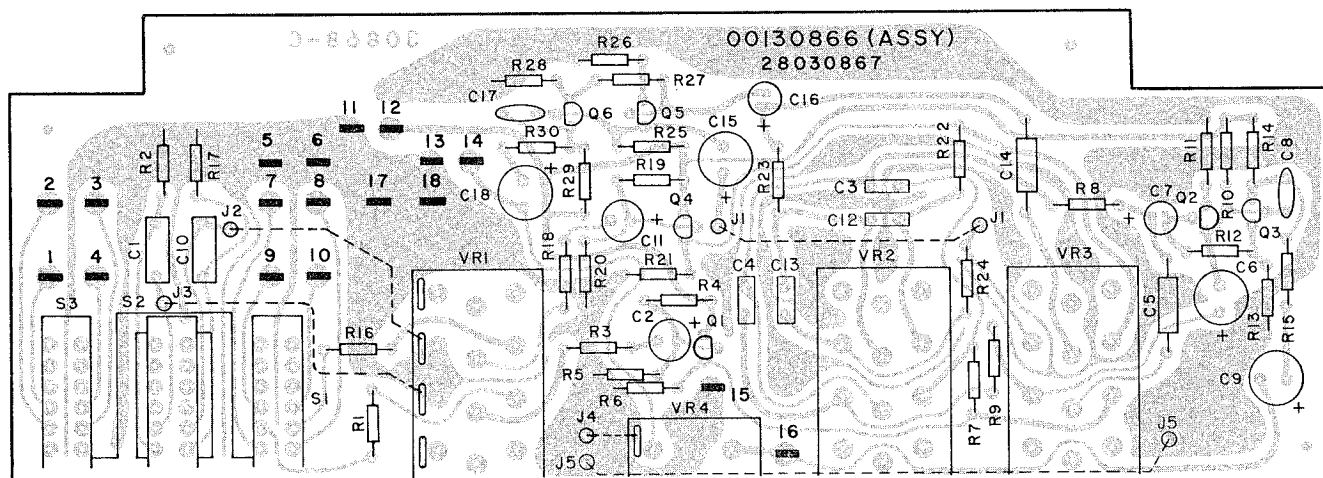

CIRCUIT REF. NO.	H/K PART NO.	DESCRIPTION
	00130866	PC Bd Assy, Volume/Mode/Switch/Tone Control
CAPACITOR, LYTIC		
C2, 11	31819165	10UF, 35V
C6, 9, 15, 18	31819166	22UF, 35V
C7, 16	31827109	5UF, 35V
TRANSISTOR		
Q1, 2, 3, 4, 5, 6	43025972*	NPN GP
CONTROL		
VR1	23029027	Volume
VR2, 3	23029029	Bass & Treble
VR4	21530909	Balance
SWITCH		
S1, 2, 3	25028939	Pushbutton, 4PDT

NOTES: UNLESS OTHERWISE SPECIFIED

1. ALL CAPACITOR VALUES IN MICROFARADS
2. ALL RESISTOR VALUES IN OHMS, $\pm 10\%$, 1/4W
3. ALL SWITCHES SHOWN IN OFF (OUT) POSITION.
4. MECHANICAL LINKAGE EXISTS BETWEEN THE FOLLOWING COMPONENTS: S1L & S1R, S2L & S2R, S3L & S3R, VR1L & VR1R, VR2L & VR2R, VR3L & VR3R.
5. CAUTION: WHEN ORDERING PARTS REFER TO PARTS LIST FOR H/K PART NO. IF NOT AVAILABLE USE REF DES AND ASSEMBLY USED ON. 1E TONE CONTROL BOARD 00130866

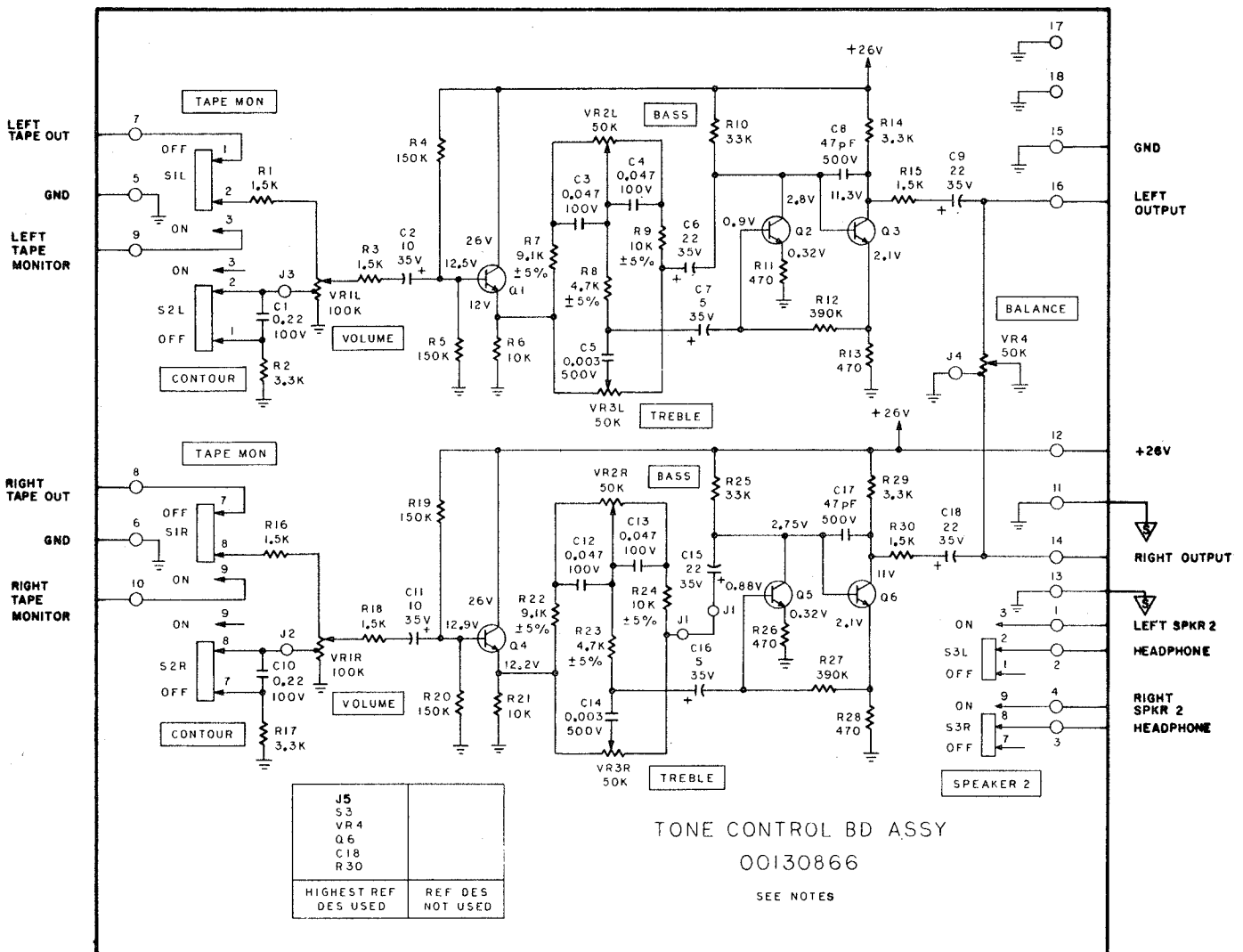

MPX/MUTING BOARD

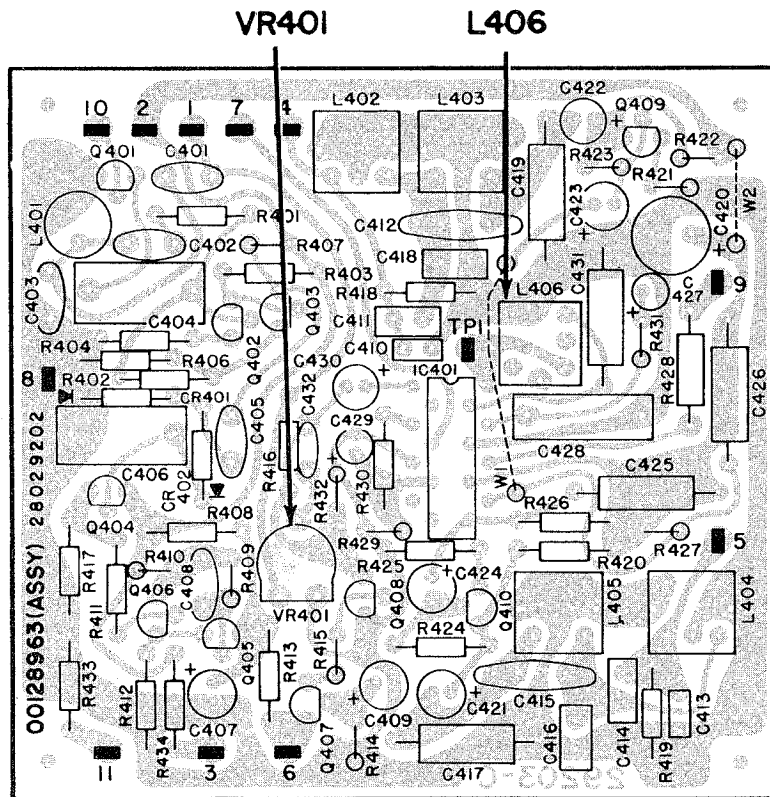

CIRCUIT REF. NO.	H/K PART NO.	DESCRIPTION
	00128963	PC Bd Assy, MPX/Muting
CAPACITOR, LYTIC		
C407	31827109	5UF, 35V
C409, 421, 422, 423, 424, 430,	31819176	10UF, 25V
C420	31819180	100UF, 16V
C427	31819157	1UF, 50V
C429	31827111	2UF, 35V
POTENTIOMETER		
VR401	21729331	50K PIHER PT1C
DIODE		
CR401, 402	41629338*	1N914
TRANSISTOR		
Q401 - Q410	43025972*	NPN GP
INDUCTOR		
L401	12028060	3.3MH
L402, 403, 404, 405	12029348	Variable 15MH
L406	12029349	Variable 1-3MH
INTEGRATED CIRCUIT		
IC401	43129350*	CA3090

NOTES: UNLESS OTHERWISE SPECIFIED

1. ALL CAPACITOR VALUES IN MICROFARADS
2. ALL RESISTOR VALUES IN OHMS. ±10%, 1/4W.
3. MEASUREMENT INFORMATION
SPEAKER SWITCHES 1 & 2—ON (IN) POSITION,
HIGH CUT, FM MUTING, CONTOUR AND TAPE MONITOR
SWITCHES—OFF (OUT) POSITION.
VOLUME CONTROL—FULL CCW.
BALANCE, BASS AND TREBLE CONTROL—CENTERED.
FUNCTION SWITCH MODE—FM STEREO.
FM TUNER—FULL CCW.
4. CAUTION: WHEN ORDERING PARTS REFER TO PARTS LIST FOR
H/K PART NO. IF NOT AVAILABLE USE REF DES AND
ASSEMBLY USED ON. IE VR401 MPX/MUTING
BOARD 00128963

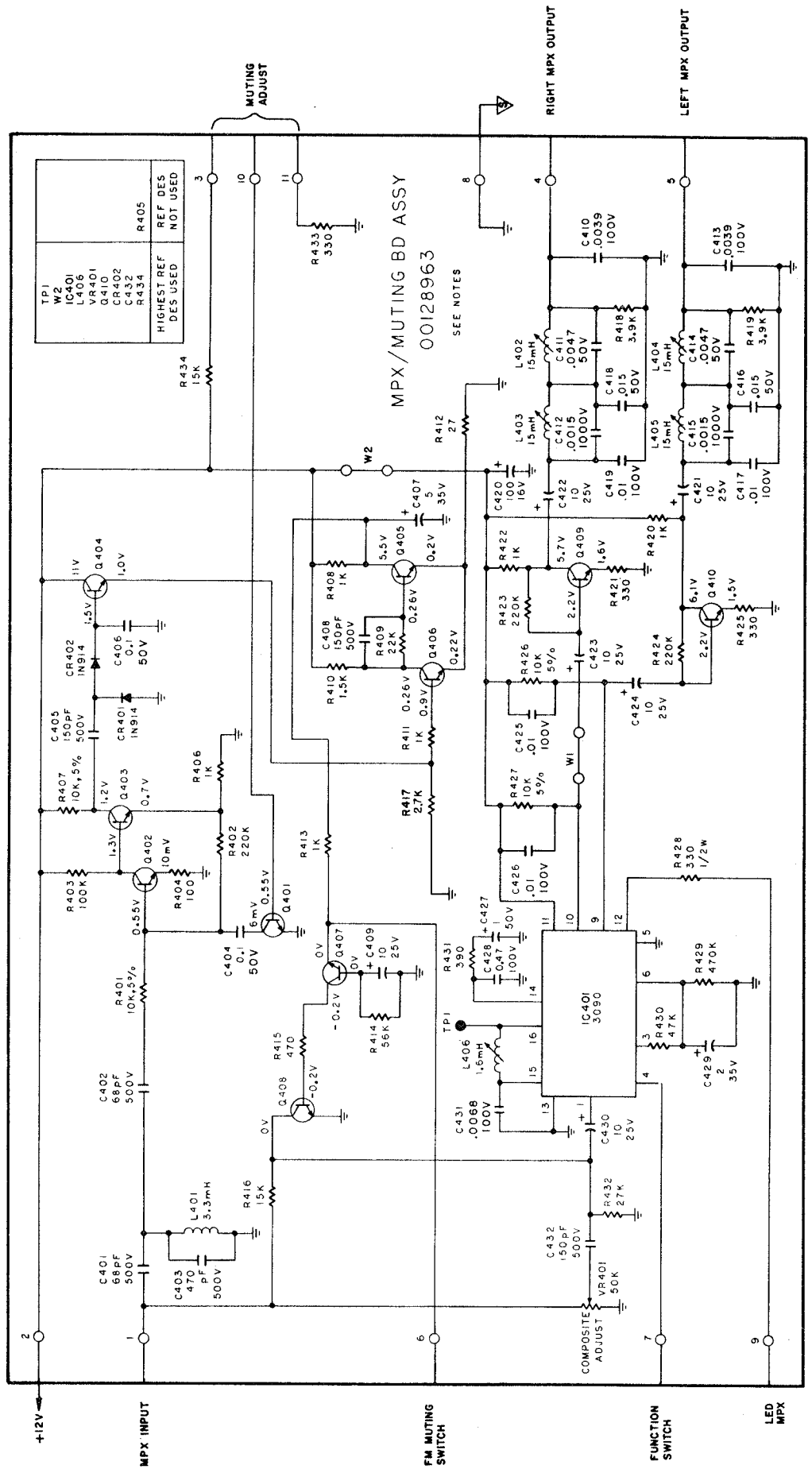

DIAL LIGHT BOARD

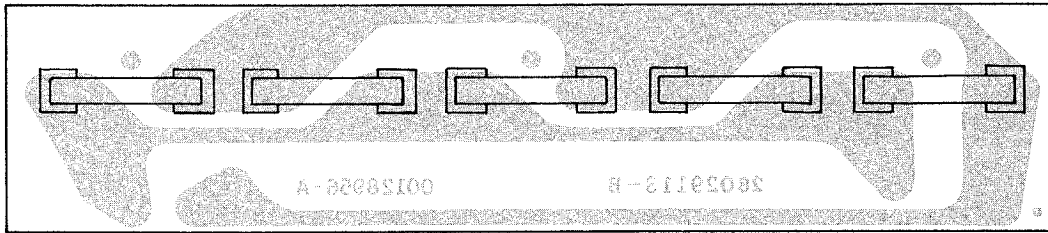

CIRCUIT REF. NO.	H/K PART NO.	DESCRIPTION
	00128956	PC Bd. Assy. Dial Light
	46529212*	Lamp, Incandescent, Fuse Type, 12V, 150MA

METER LIGHT BOARD

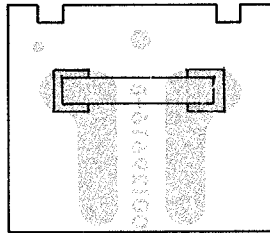

CIRCUIT REF. NO.	H/K PART NO.	DESCRIPTION
	00129616	PC Bd. Assy. Meter Light
	46529212*	Lamp, Incandescent, Fuse Type, 12V, 150MA

LED LIGHT BOARD

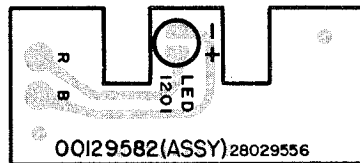

CIRCUIT REF. NO.	H/K PART NO.	DESCRIPTION
	00129582	PC Bd. Assy. Led Light
LAMP		
LED1201	46729554*	LED

STRINGING DIAGRAM

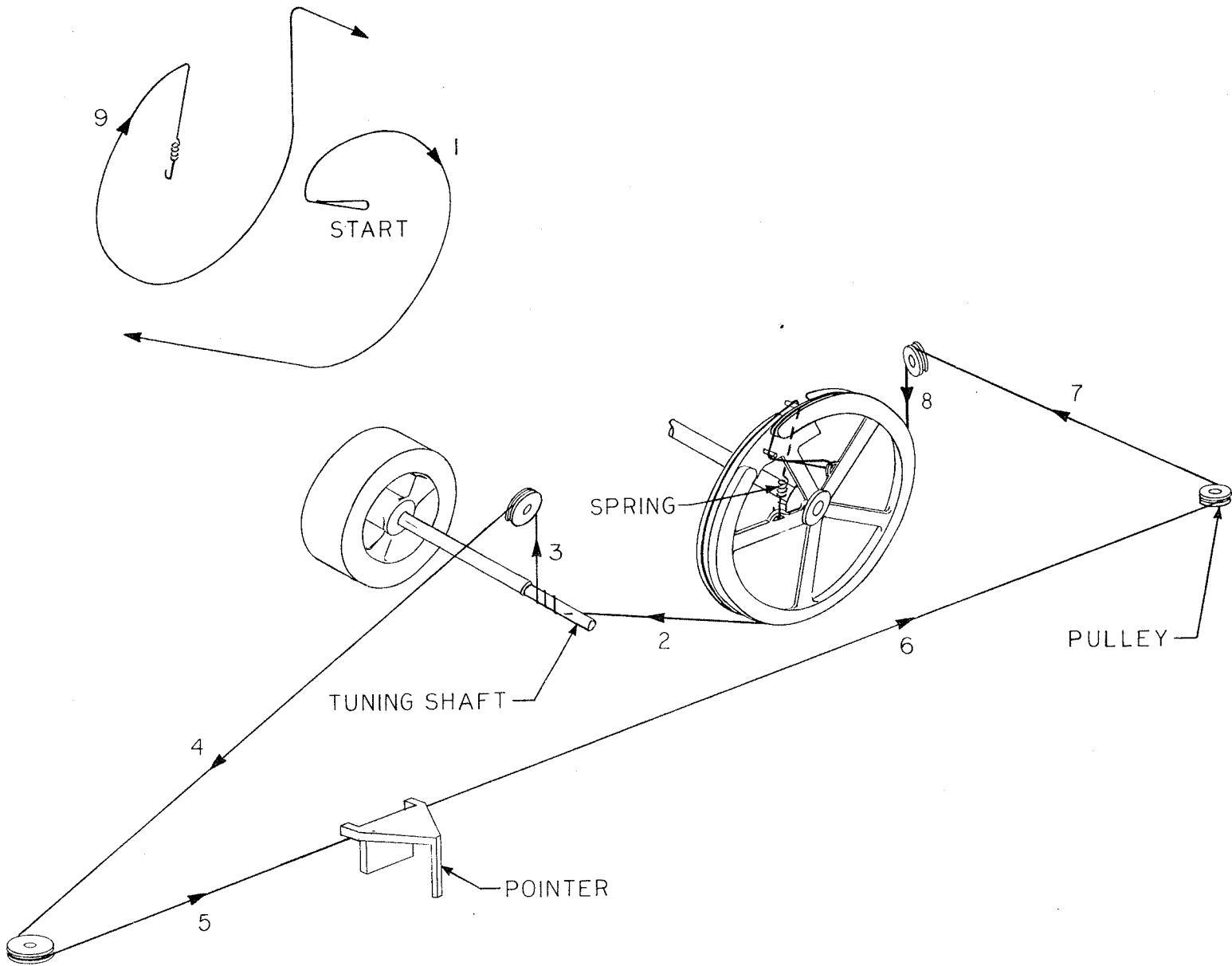

CHASSIS PARTS LIST

FIG. NO.	REF. DES.	H/K PART NO.	DESCRIPTION
REAR PANEL			
Ref		65428932	Terminal Strip, 4 Position, Screw Type
Ref		65429098	Terminal Strip, 3 Position, Screw Type
Ref		65429087	Phono Jack Assy., Dual
I-1	VR1	21529274	Control, FM Muting, 1K, 1/4W, AF
II-2	S2	24029081	Function Switch
Ref		65430907	Input Board Assy.
Ref		65429317	Phono Jack (P/O 65429087 & 65430907)
Ref		65416751	Receptacle, AC
II-7		65427001	Fuse Holder with Hdwr (Bus HTA)
II-6	F1	45022346*	Fuse, Slo-Blo, 2 Amp, 3AG, 250V
I-2		60129790	Antenna Bracket
I-3		20529838	Antenna, Loopstick
I-4		61629867	Arm, Antenna Extension
Ref	R3	33312251	Resistor, 2.2M ohm, ±10%, 1/2W
FRONT PANEL			
Ref		60131630	Front Panel, Fabricated and Painted
Ref	S1	25028964	AC Power Switch
Ref		65428021	Jack, Phono and Tape
I-10		60429254	Tuning Shaft
Ref	DS1-DS5	46528051*	Function Lamp, Mura 12V, 60mA
Ref	M1	12528968	Tuning Meter
Ref		61629039	Dial Scale, Plexiglas Molded
I-5		60729783	Pointer, Painted
ESCUTCHEON ASSEMBLY			
Ref		00231640	Escutcheon Assy.
Ref		61631596	Escutcheon Plexiglas, Upper Fab Panel
Ref		63029034	Escutcheon Insert, Bottom Fab
Ref		63032142	Escutcheon Right Panel Insert
Ref		61632141	Function Panel Window, Plexiglas
Ref		90432143	Function Panel, Fab and Screened
Ref		63228698	Control Knob, Volume, Balance & Function
Ref		63228701	Tone Control Knob, Outer, Bass & Treble
Ref		63228702	Tone Control Knob, Inner, Bass & Treble
Ref		63228915	Tuning Knob
Ref		63228700	Pushbutton Knob
Ref		63228962	Pushbutton Knob, AC Switch

FIG. NO.	REF. DES.	H/K PART NO.	DESCRIPTION
CHASSIS ASSEMBLY			
I-6	T1	10128960	Power Transformer
I-7		00329346	AM/FM Front End
I-9		60829328	Drive Pulley 89mm SD
II-4	C4	31525666	Capacitor, Lytic, 470UF, 35V
II-5	C5	31519169	Capacitor, Lytic, 3000UF, 50V
I-8	C6, 7	31130627	Capacitor, Lytic, 13000UF, 40V
II-3	CR1	42129602	Diode Bridge, 5 Amp, 100 PIV
I-11	L1	12029678	Inductor, Fixed 3UH
MISCELLANEOUS			
Ref		63632494	Walnut Cabinet, 3 Sides and Bottom Strip
EXPORT			
I-6	T1	10131595	Power Transformer
I-1	S3	24031643	Switch, Multi Voltage
II-7	F1	45031050*	Fuse, Slo-Blo, 1 Amp, 3AG, 250V

NOTE TO WARRANTY STATIONS: Items marked by asterisk (*) are recommended spare parts stock. Printed circuit board assembly numbers are shown for reference only. Harman/Kardon does not normally supply assembled printed circuit boards.

NOTE: To speed handling of your order be sure to include both the model and serial numbers, in addition to the quantity, part number and part description of the items ordered. Orders from independent dealers, independent servicemen, and retail customers will be shipped on a cash in advance basis. Harman/Kardon reserves the right to substitute equivalent parts for those originally installed in this chassis. All parts should be ordered from Harman/Kardon, 55 Ames Court, Plainview, L.I., N.Y. 11803, Att: Parts Department.