

JVC

SERVICE MANUAL

MODEL

CX-500GB / CX-500EU

12cm COLOUR TV-RADIO-CASSETTE RECORDER



CONTENTS

1. SAFETY PRECAUTION	2
2. DISASSEMBLING INSTRUCTIONS	3 ~ 6
3. INSTALLING THE DIAL CORDS	7
4. ADJUSTMENT OF THE POWER SUPPLY BLOCK	8
5. ADJUSTMENT OF COLOR TV UNIT	8 ~ 11
6. ADJUSTMENT OF CASSETTE TAPE RECORDER UNIT	12 ~ 14
7. SERVICE GUIDE FOR CASSETTE TAPE RECORDER UNIT	15 ~ 16
8. ALIGNMENT BY MEANS INSTRUMENTS	17 ~ 23
9. REPLACEMENT PARTS LIST	24 ~ 35
10. BLOCK DIAGRAM	36
11. VHF/UHF E TUNER SCHEMATIC	37
12. PACKING DIAGRAM	38
13. OPTIONAL ACCESSORIES	38

SPECIFICATIONS

TV standard	CCIR-PAL and CCIR-SECAM system
TV channels	CCIR and OIRT channels VHF: CCIR 2-12, OIRT 1-12 CCIR and OIRT channels UHF: CCIR and OIRT 21-69
Radio frequency ranges	FM 88 - 108 MHz, MW 510 - 1600 kHz, LW 150 - 350 kHz
Antennas	Built-in rod antenna for TV and FM radio Built-in ferrite core antenna for MW and LW radios
Ext. antenna impedance	75Ω aerial (for TV and FM radio)
TV tuner	Contact-less electronic tuner
Picture tube	12 cm, picture measured diagonally, 55 degrees deflection.
TV High voltage	12 kv at zero beam current
TV Intermediate frequency	
Video IF carrier	38.9 MHz
Sound IF carrier	33.4 MHz, 32.9 MHz or 32.4 MHz selectable
Color sub carrier	34.47 MHz
Semi-conductors	11 ICs, 25 Transistors, 43 Diodes
Speaker	12 cm round type, 6 ohm, 1 pc.
Tape	Philips type cassette
Track system	2-track monaural
Monitor system	Variable sound monitor
Rewind time	Within 100 sec. (with C-60 cassette)
Fast forward time	Within 100 sec. (with C-60 cassette)
Wow & flutter	Less than 0.3 % (WRMS)
Recording system	AC bias system
Erasing system	AC erasing system
S/N ratio	48 dB
Frequency characteristics	80 - 10,000 Hz
Mike jack	-70 dBs (0.25 mV)
DIN jack	IN -70 dBs (0.25 mV) OUT 0 dBs (0.78 V)
Built-in mike	Condenser microphone
Audio output	2.0 W at 10 % distortion
Power input	AC 110 V, 127 V, 200 - 220 V and 240 V, 50/60 Hz DC 15 V (10 "D" size batteries), DC 12 V car battery with car battery cord (Model AP-23) option or DC 12 V rechargeable battery (Model CB-15E) option.
Power consumption	32 W on AC, 17 W on DC 12 V (Recording from TV with sound max.)
Dimensions	Height: 13.5 cm Width: 43.8 cm Depth: 33.0 cm - without handle
Weight	7.7 kg - without "D" size batteries

1. SAFETY PRECAUTION

1. The design of this product contains special hardware, many circuits and components specially for safety purposes.
For continued protection, no changes should be made to the original design unless authorized in writing by the manufacturer. Replacement parts must be identical to those used in the original circuits. Service should be performed by qualified personnel only.
2. Alterations of the design or circuitry of receiver should not be made. Any design alterations or additions will void the manufacturer's warranty and will further relieve the manufacturer of responsibility for personal injury or property damage resulting therefrom.
3. Many electrical and mechanical parts in television sets have special safety-related characteristics. These characteristics are often not evident from visual inspection nor can the protection afforded by them necessarily be obtained by using replacement components rated for higher voltage, wattage, etc. Replacement parts which have these special safety characteristics are identified in the parts list of Service manual. **Electrical components having such features are identified by shading on the schematics and by (⚡) on the parts list in Service manual.** The use of a substitute replacement which does not have the same safety characteristics as the recommended replacement part shown in the parts list in Service manual may create shock, fire, or other hazards.
4. If any repair has been made to the chassis, it is recommended that the B₁ setting should be checked or adjusted (See ADJUSTMENT OF B₁ POWER SUPPLY).
5. The high voltage applied to the picture tube must conform with that specified in Service manual. Excessive high voltage can cause an increase in X-Ray emission, arcing and possible component damage, therefore operation under excessive high voltage conditions should be kept to a minimum, or should be prevented. If severe arcing occurs, remove the AC power immediately and determine the cause by visual inspection (incorrect installation, cracked or melted high voltage harness, poor soldering, etc.). To maintain the proper minimum level of soft X-Ray emission, components in the high voltage circuitry including the picture tube must be the exact replacements or alternatives approved by the manufacturer of the complete product.
6. Do not check high voltage by drawing an arc. Use a high voltage meter or a high voltage probe with a VTVM. Discharge the picture tube before attempting meter connection, by connecting a clip lead to the ground frame and connecting the other end of the lead through a 10K Ω 2W resistor to the anode button.

CAUTION:

When AC operating, turn the voltage selector to the position corresponding to the mains source in your area before connecting mains lead to the house current receptacle.

The voltage selector has 4 positions, i.e. 240V, 220 – 200V, 127V and 110V.

7. When service is required, observe the original lead dress. Extra precaution should be given to assure correct lead dress in the high voltage circuit area. Where a short circuit has occurred, those components that indicate evidence of overheating should be replaced. Always use the manufacturer's replacement components.

8. ISOLATION CHECK

(SAFETY FOR ELECTRICAL SHOCK HAZARD)

After re-assembling the product, always perform an isolation check on the exposed metal parts of the cabinet (antenna terminals, channel selector knobs, metal cabinet, screwheads, earphone jack, control shafts, etc.) to be sure the product is safe to operate without danger of electrical shock.

(1) Dielectric Strength Test

The isolation between the AC primary circuit and all metal parts exposed to the user, particularly any exposed metal part having a return path to the chassis should withstand a voltage of 3,500V AC (r.m.s.) for a period of one minute.

This method of test requires a test equipment not generally found in the service trade.

(2) Leakage Current Check

Plug the AC line cord directly into the AC outlet (do not use a line isolation transformer during this check.) Using a "Leakage Current Tester", measure the leakage current from each exposed metal part of the cabinet, particularly any exposed metal part having a return path to the chassis, to a known good earth ground (water pipe, etc.). Any leakage current must not exceed 0.5 mA.

Alternate Check Method

Plug the AC line cord directly into the AC outlet (do not use a line isolation transformer during this check.) Use an AC voltmeter having 1,000 ohms per volt or more sensitivity in the following manner. Connect a 1500 Ω 10W resistor paralleled by a 0.15 μ F AC-type capacitor between an exposed metal part and a known good earth ground (water pipe, etc.).

Measure the AC voltage across the resistor with the AC voltmeter.

Move the resistor connection to each exposed metal part, particularly any exposed metal part having a return path to the chassis, and measure the AC voltage across the resistor. Now, reverse the plug in the AC outlet and repeat each measurement. Any voltage measured must not exceed 0.35V AC (r.m.s.). This corresponds to 0.5mA AC (r.m.s.).

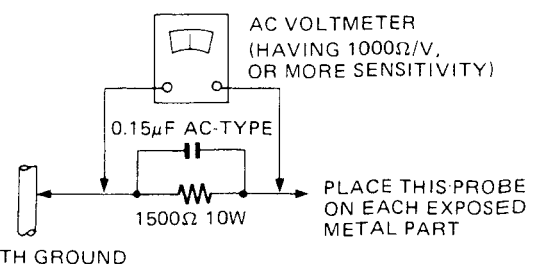

2. DISASSEMBLING INSTRUCTIONS

REMOVING THE REAR COVER

Unfasten the six screws marked (A) in Fig. 1. From the battery housing, disconnect connector B which is connected to the power source circuit board. Finally remove the rear cover.

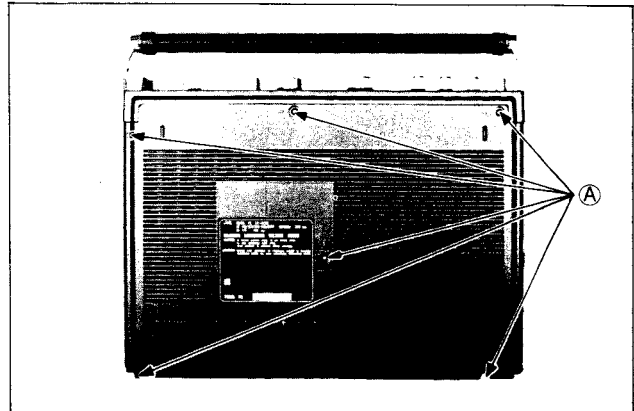

Fig. 1

REMOVING THE COLOR TV P.C. BOARD

Unfasten the three screws marked (A) in Fig. 2 to remove bracket (B). After lifting and pulling both the color TV P.C. board and the side control panel, turn the unit upside down as shown in Fig. 3. Both alignment and repair of the color TV unit can be conducted without requiring further disassembling.

Should any parts other than the color TV unit require alignment or repair, lift and remove both the color TV P.C. board and the side control panel (without disconnecting them from each other), and preferably position the unit with the side control panel facing downward, as illustrated in Fig. 4. This is the safest positioning, and is recommended for adjusting purity or convergence. Remove the wire clamps if necessary.

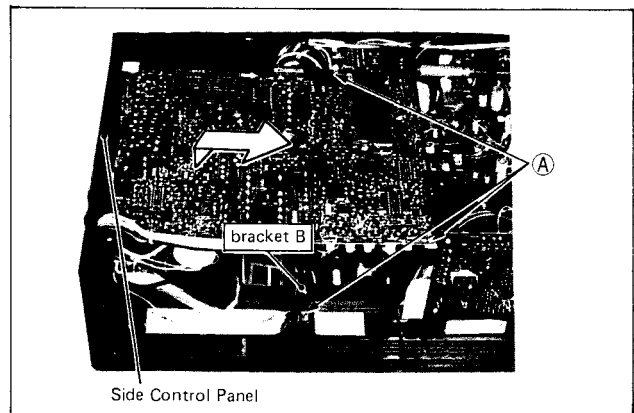

Fig. 2

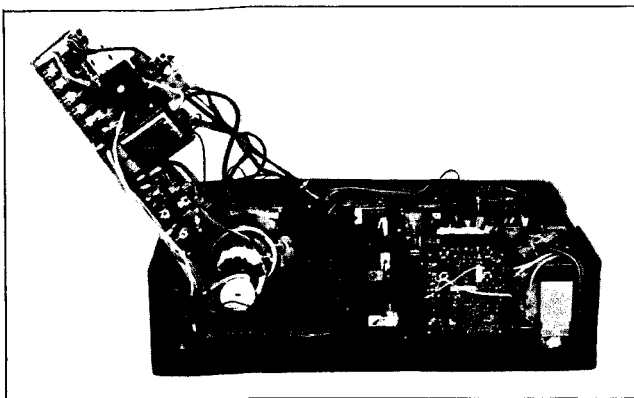

Fig. 3

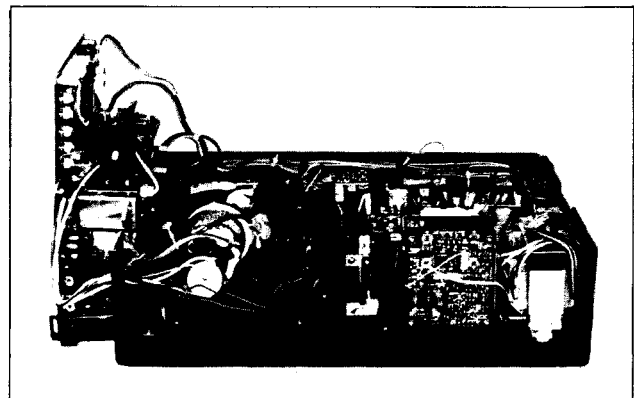

Fig. 4

REMOVING THE POWER SUPPLY BLOCK

After removing the color TV P.C. board, remove the entire power supply block while unfastening the three screws marked (A) in Fig. 5.

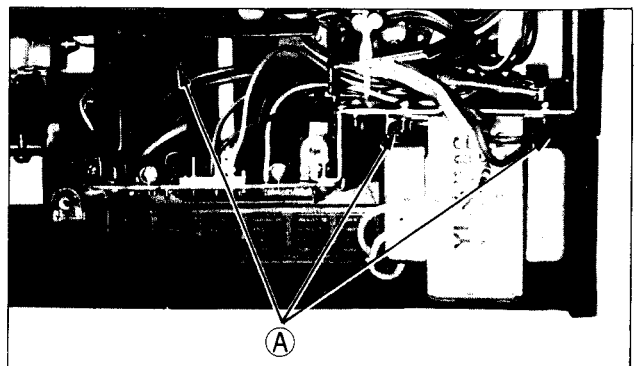

Fig. 5

REMOVING BOTH THE RADIO/ AMPLIFIER P.C. BOARD AND CONTROL BASE

Remove both the color TV P.C. board and the power supply block. Pull off both the six alignment knobs and connector D from the dial light switch on the front side. Then adhere to the following procedures:

1. Unfasten the nine screws marked (A) in Fig. 6.
 2. Lift the rear part of the radio/amplifier printed circuit board.
 3. Remove the control base by pulling it forward and lifting the left edge of the base.
 4. Pull the knob shafts out from the front panel holes, while paying due heed to the recording springs.
 5. Pull out the dial cord to the rear side of the unit, being careful not to allow the cord to be caught by the dial light switch.
 6. By connecting connector A to the power source and the wire to the speaker, the unit will function normally even under this partially disassembled state.
- **When reassembling the radio/amplifier P.C. board and the control base:**
1. Insert the control base between the front panel and the dial light switch. Be careful not to damage the dial surface with the dial switch.
 2. Push the knob shafts into the front panel holes while lifting the rear side of the circuit board, paying attention not to damage the recording spring.
 3. By slightly pushing the left side of the control base upward and forward, the control base can be hooked onto the stopper.

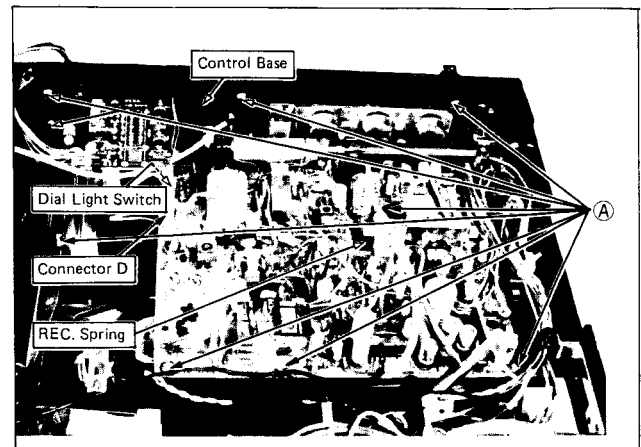

Fig. 6

REMOVING THE RADIO/AMPLIFIER P.C. BOARD

After removing from the unit the radio/amplifier P.C. board connected to the control base, adhere to the following procedures:

1. Pull the meter off by softly pushing on its upper portion with a finger (see Fig. 7).
2. Unfasten the four nuts marked (A) and one screw marked (B) in Fig. 7.
3. Unfasten the screw marked (C) in Fig. 7, at the center of the radio variable capacitor pulley, and then extract the pulley from the variable capacitor shaft.
4. By pulling the connectors out of their positions, the radio/amplifier P.C. board can be separated. By connecting connector A to the power source and the wire to the speaker, the unit functions normally even under this partially disassembled state.

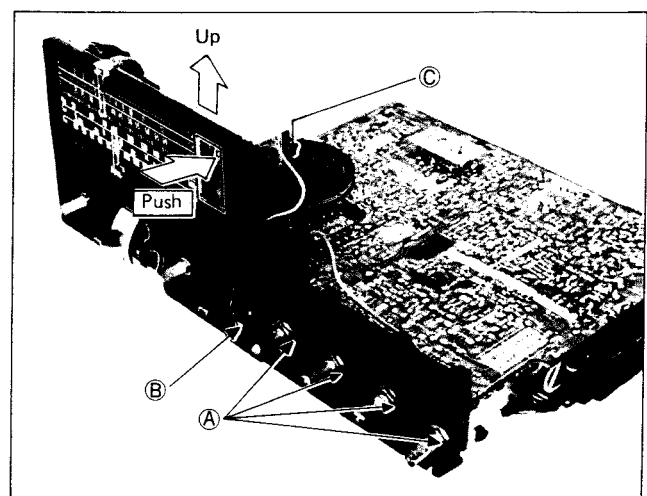

Fig. 7

REMOVING THE CASSETTE RECORDER UNIT

Unfasten the four screws marked (A) in Fig. 8 and pull out the cassette recorder unit while holding its rear side upward.

By connecting connectors N, P, and R from the radio/amplifier printed circuit board to the power source, the unit functions normally even under this partially disassembled state.

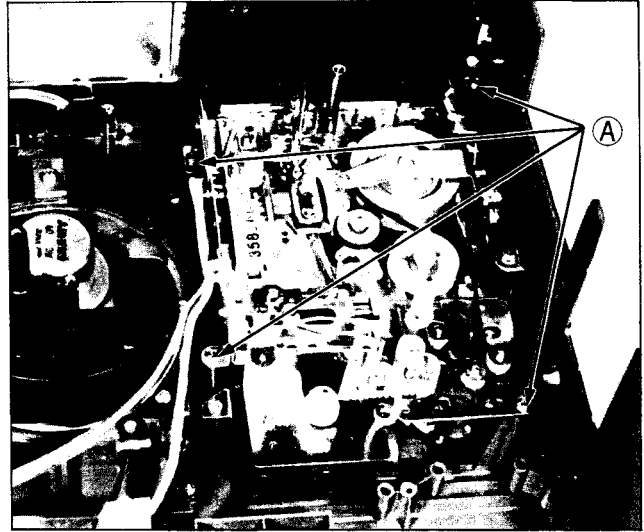

Fig. 8

REMOVING THE PICTURE TUBE

By removing the color TV P.C. board and unfastening the four screws marked (A) in Fig. 9, the picture tube can be removed from the unit.

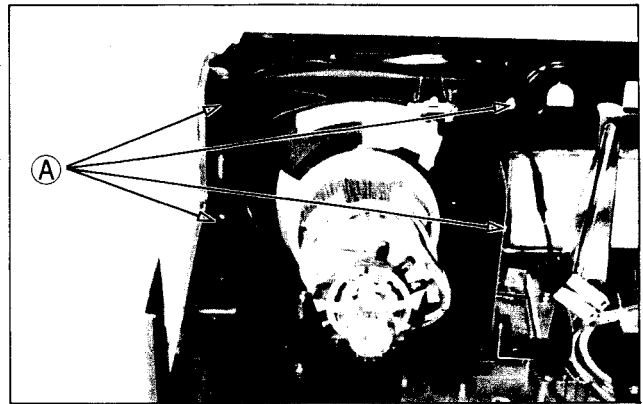

Fig. 9

REMOVING THE HANDLE AND THE FRONT PANEL

Remove the color TV P.C. board, control base, radio/amplifier P.C. board, and CRT from the unit.

Pull off the two plate springs marked (A) in Fig. 10 in the arrow-marked direction and remove the handle while expanding it.

Then unfasten the three screws marked (B) in Fig. 10 to remove the front panel.

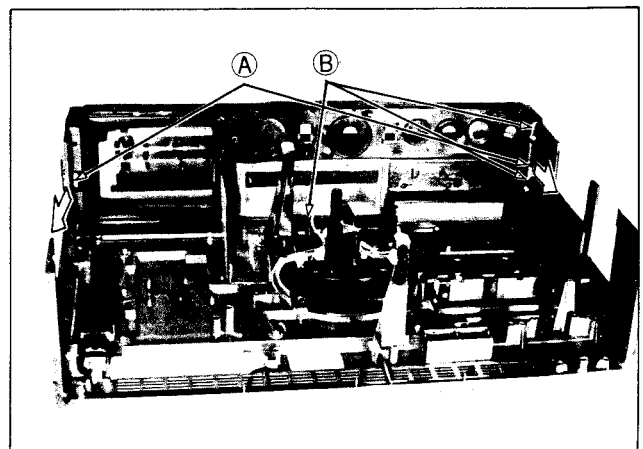

Fig. 10

REMOVING THE ROD ANTENNA

After raising the color TV P.C. board and unfastening the three screws marked (A) in Fig. 11, pull the rod antenna inward.

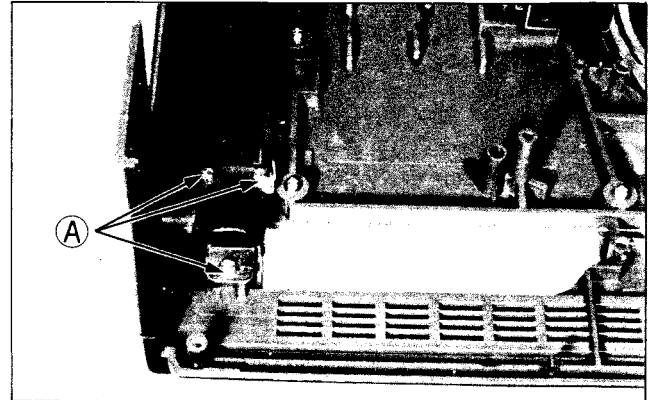

Fig. 11

REMOVING THE CASSETTE DOOR

Pull out Section (B), while depressing hard Section (A) with a finger. (See Fig. 12).

To remount the cassette door, press the door spring against the stopper groove on the right side, push in the left stopper, and then insert the right stopper into the groove.

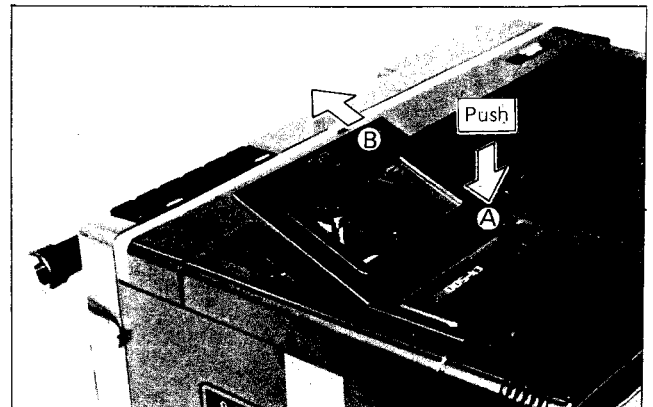

Fig. 12

REMOVING THE CRT PROTECTOR GLASS

Remove the CRT protector glass by inserting a thin-bladed screwdriver into the notch on its right end and forcing the glass upward. It is recommended that waste cloth be applied to protect the panel from being damaged (see Fig. 13).

WIRE CLAMPING AND TYING BAND

1. Be sure to clamp the wire.
2. Never remove the tying band used for wire clamping. Should it be inadvertently removed, be sure clamp the wire again, using insulating material.

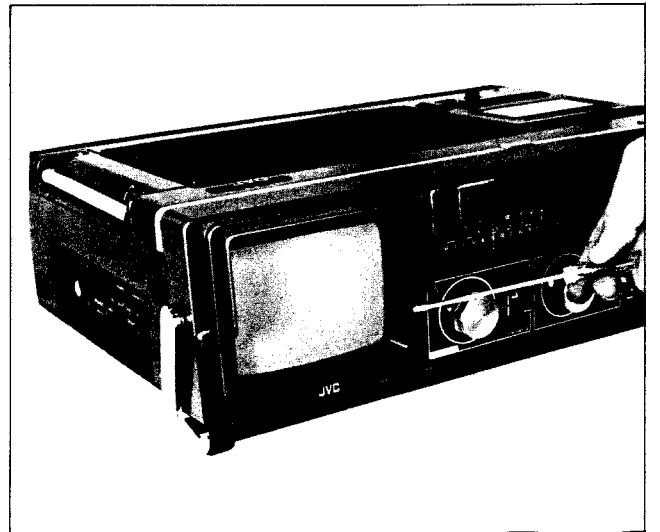

Fig. 13

SETTING THE LOOP WIRES

Two loop wires in the unit are the grounding wires to improve the sensitivity while using the rod antenna. Set these wires in loop shape by using a clasper.

Short wire 62 cm : for high channel
Long wire 140 cm : for low channel

3. INSTALLING THE DIAL CORDS

SETTING THE RADIO DIAL CORD

1. Separate the control base from the radio/amplifier P.C. board.
2. After aligning the pulley marked (A) in Fig. 14 to the position indicated on the figure, set the cord in the order shown by the encircled numbers.
3. After fully rotating the variable capacitor of the radio/amplifier printed circuit board counterclockwise when viewed from the printed circuit board rear side, insert the capacitor shaft into pulley (A).
4. While receiving a radio program and aligning the pointer to the output frequency of the radio station, paint-lock the radio dial cord.

SETTING THE COLOR TV DIAL CORD

1. Remove both the control base and the radio/amplifier P.C. board.
2. After aligning the pulley marked (B) in Fig. 14 to the position indicated on the figure, set the cord in the order shown by numbers in the triangles.
3. While receiving a TV program and aligning the pointer to the channel, paint-lock the TV dial cord.

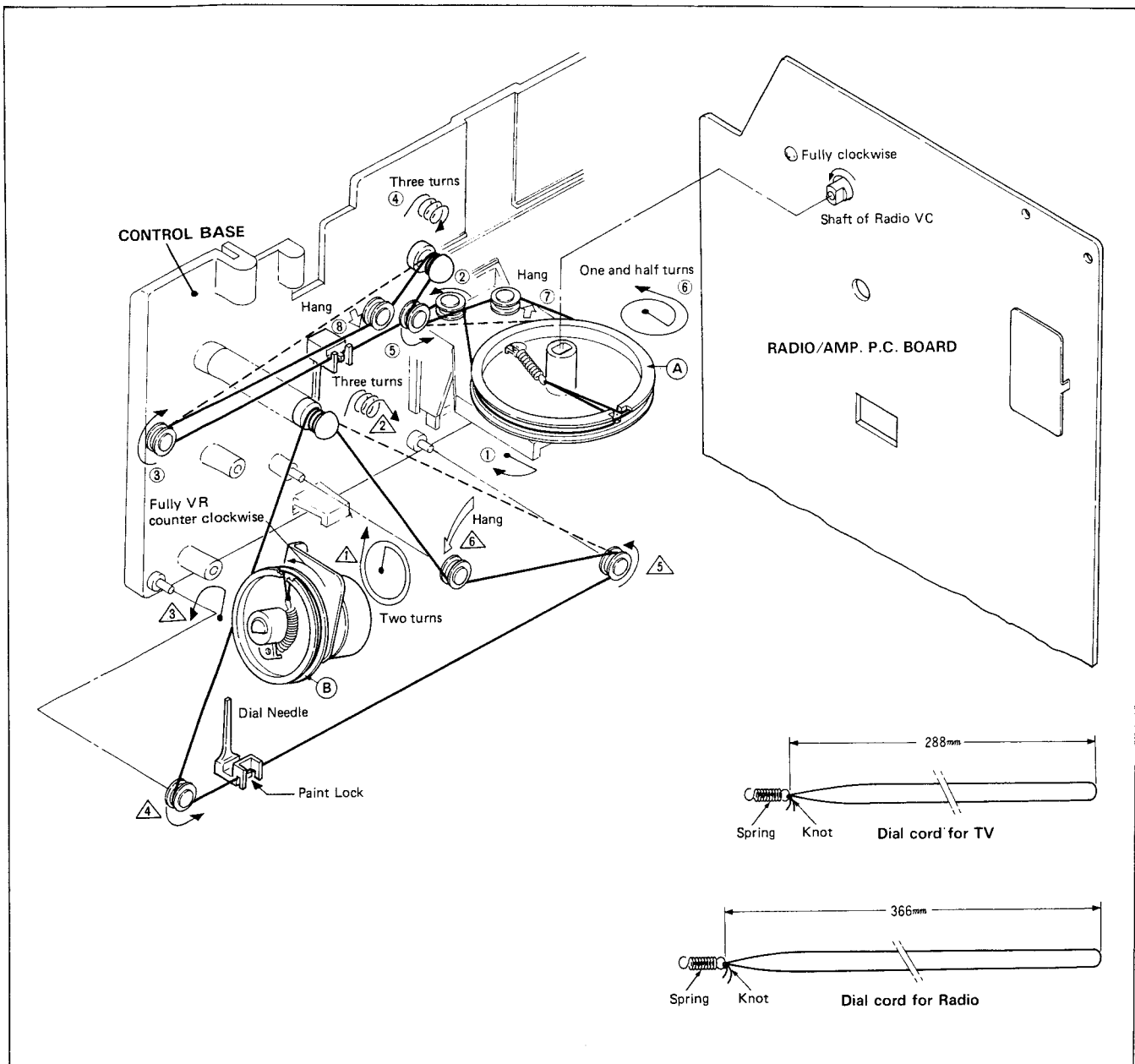

Fig. 14

4. ADJUSTMENT OF THE POWER SUPPLY BLOCK

ADJUSTING THE B₁ VOLTAGE (10.7V)

B₁ voltage adjustment should be conducted prior to repair and/or alignment.

1. Set the power change-over switch to the "TV" position.
2. Rotate the B₁ adjusting VR so that DC voltage between the TP-91 in the power supply block and the grounding wire becomes 10.7V (see Fig. 15). Concurrently, confirm that the TP-92 in the TV P.C. board indicates 10.5V.
3. Employ a precision testor (within resistance 20KΩ/V or more) for this adjustment.

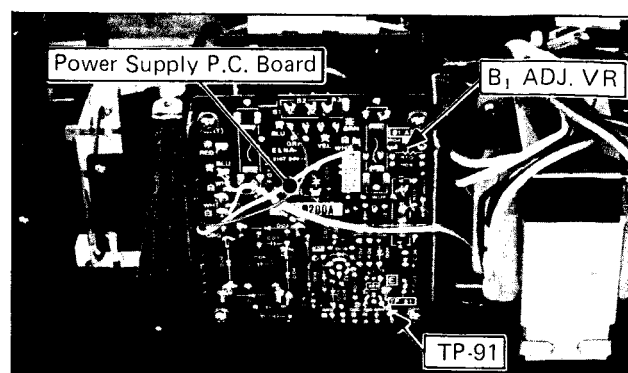

Fig. 15

5. ADJUSTMENT OF COLOR TV UNIT

ADJUSTING THE SUB COLOUR VR

While receiving a color TV program, set the COLOUR knob on the side control panel to the central position (where it click). Then align the subcolour VR in the printed circuit board until the colour of human skin looks natural.

ADJUSTING THE SUB CONTRAST AND SUB BRIGHT VR'S

While receiving a TV program, set the BRIGHT knob to the click position, fully rotate the PICTURE knob clockwise and then return it about 45°. Then align both the sub bright VR (on the side control panel) and the sub-contrast VR (on the P.C. board) until an ideal picture is obtained.

ADJUSTING THE HORIZONTAL WIDTH AND VERTICAL HEIGHT

1. Receive an image such as a circle or cross hatching to enable confirming horizontal and vertical symmetry.
2. While rotating the horizontal width coil core and the vertical height VR, obtain the correct image shape.

ADJUSTING THE FOCUS

1. While rotating the focus VR clockwise, set the VR at the position where maximum focusing is ensured.
2. Confirm that focusing is ideal even while darkening the picture.

ADJUSTING THE NOISE VR

Conduct adjustment when noises are produced on the picture tube or when striped-pattern interfering waves are observed in a weak wave district.

1. Fully rotate the noise VR counterclockwise (noises are observed on the tube).
2. Gradually rotate it clockwise until the noises disappear.
3. Then confirm that there is no noise observable in other channels.

ADJUSTING THE HORIZONTAL SYNCHRONIZATION

1. Using a short jumper, short-circuit between TP-33A and TP-33B.
2. While rotating the H. FREQ. VR, keep the picture stationary or slowly moving.
3. Then confirm that there is no abnormality in all the channels after removing the short jumper.

ADJUSTING THE TUNING DIAL

1. Turn off the A.F.C. switch on the side control panel.
2. Change over the TV band selector switch on the front panel to the VHF VL position.
3. While rotating the TV channel selecting knob, set the dial pointer to that channel number of the TV station which is central among those receivable.
4. Rotate the VL subtuning VR and receive a TV program from the station whose channel number is set on the dial pointer.
5. By attempting to receive other stations within the band, confirm that the pointer corresponds to the channel number of each station.
6. After changing over the TV band selector switch to VHF V_H and UHF (U) respectively, adjust by rotating the V_H or the UHF subtuning VR in the same manner.
7. Turn ON the A.F.C. switch.

<NOTE> As the VHF channel numbers for CCIR countries are printed on the TV channel indicator, adjust the dial pointer referring below table in another countries.

Receiving VHF TV channels (All UHF TV CHs; common) / * Mark; Receiving CHs limited														
CCIR countries	1	2	3	4		5	6	7	8	9	10	11	12	
OIRT countries	1	2		3	4	5		6	7	8	9	10	11	12
Italy		A	B		C			D	E	F	G	H	H1	H2
French territories								4	5	6	7	8	9	
*Australia		1	2		3	4		6	7	8	9	10	11	
*New Zealand		2	3					4	5	6	7	8	9	
*Ireland			B	C				D	E	F	G	H	J	
*Morocco								6	7	8	9	10		

[ADJUSTMENT OF PAL/SECAM CIRCUIT]

PAL CIRCUIT

1. Must be adjusting the PAL circuit before the SECAM circuit.
2. Connect a PAL colour bar generator to antenna terminal.
3. Connect a X-probe (Hor.) of oscilloscope to connector U5, Y-probe (Vert.) to connector U4 (appear Lissajous' figure shown in Fig. A-a).
4. Connect a short jumper between TP-3 and TP-4.
5. Apply bias supply (about +3.7V_{DC}) to TP-1 (appear Lissajous' figure shown in Fig. A-b).
6. Adjust C10 slightly so that the colour synchronization become unlocked and then adjust bias supply slightly so that the figure become equal in size to Fig. A-a.
7. Adjust R06 for the absence of loops (Fig. A-c), and adjust T02 so that each pair of lines merge together (Fig. A-d).
8. Adjust C10 just regain floating colour synchronization, and then remove both of the short jumper and the bias supply.

SECAM CIRCUIT

1. Receive a SECAM colour broadcast or connect a SECAM colour bar generator to antenna terminal.
2. Connect 10:1 probe of oscilloscope to TP-5.
3. Adjust T03 for the waveform shown in Fig. B.
4. Remove a receptacle wire.
5. Connect V.T.V.M. between TP-6 (+) and TP-7 (-), and then adjust T04 so that the voltage become to maximum (about 1V_{DC}).
6. Connect probe of oscilloscope to connector U4, and adjust T06 for the waveform shown in Fig. C.
7. Connect probe of oscilloscope to connector U5, and adjust T05 for the waveform shown in Fig. D.

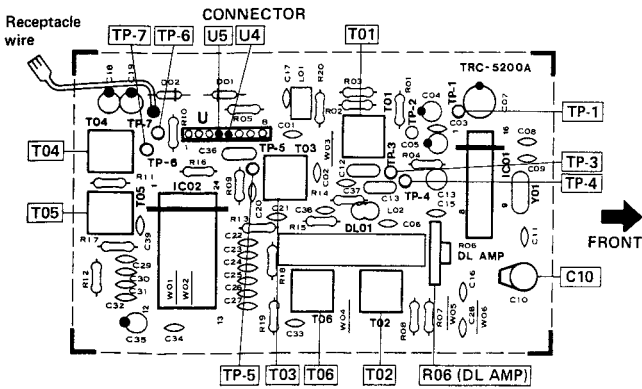
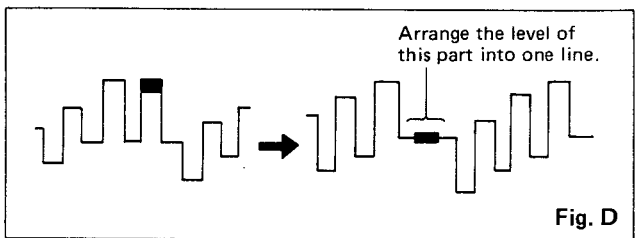
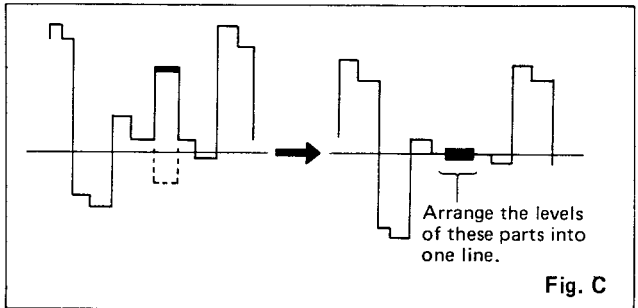
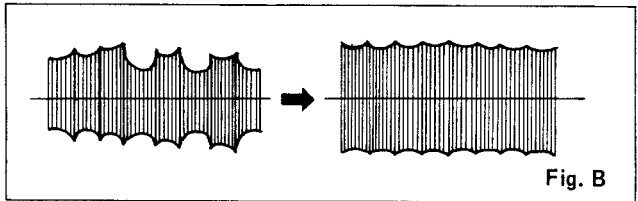
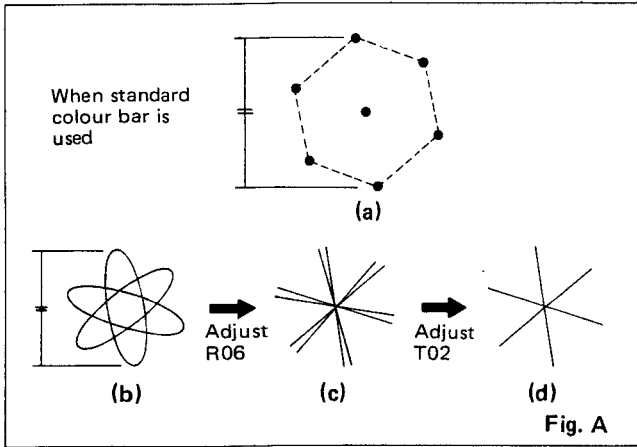

PICTURE TUBE

The picture tube is a precision in-line gun type. (In this picture tube, dynamic convergence is carried out by the precision deflection yoke it is made unnecessary to provide the picture tube with convergence yoke and convergence circuit. The adjustment of picture tube is therefore made easier as only the adjustment of static convergence by using a magnet is enough.

The deflection yoke and purity/convergence magnets assembly has been set at the factory and requires no field adjustments.

However, should the assembly be accidentally jarred or tampered with, some or all adjustments may be necessary.

ADJUSTING THE COLOR PURITY AND VERTICAL CENTER

Loosen yoke retaining clamp (Fig. 16), remove adhesive tape from the wedges. With a sharp utility or exact knife cut between the picture tube and the wedge. Remove wedges completely and clean off dried adhesive from picture tube. When reassembling new wedges to picture tube the type of wedge recommended is part No. C30195. And then rotate the magnets locking ring to clockwise before any adjustments are attempted.

1. Select no signal UHF channel.
2. Let the purity tabs come in line horizontally as is shown in Fig. 17. A long tab should be in the same direction as the other short tab.
3. Move the yoke slowly to backward.
4. Turn the green cut-off control to maximum and the red and blue cut-off controls to minimum. Then adjust the screen control so that the green ball can be seen best. (Fig. 18)
5. Rotate the two tabs in the opposite directions and with them kept at an angle, together in either direction so that the green ball is centered on the picture tube.
6. Check the vertical center position by displaying a horizontal line. Unless correct, bring it to the center by rotating the two tabs, kept at an angle, together in either direction. (Fig. 19, 20)
7. Repeat steps 4 and 5 alternately until the green ball and the vertical center come to the center.
8. Move the yoke slowly towards the bell of the tube so that the whole surface of the picture tube is filled with a green pure raster.
9. Turning red or blue cut-off control to maximum and red cut-off control to minimum, make sure of a red or blue pure raster.
10. Secure yoke retaining clamp (do not install wedges at this time).

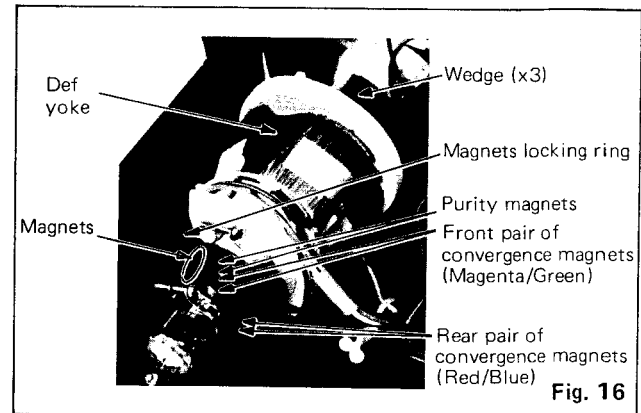

Fig. 16

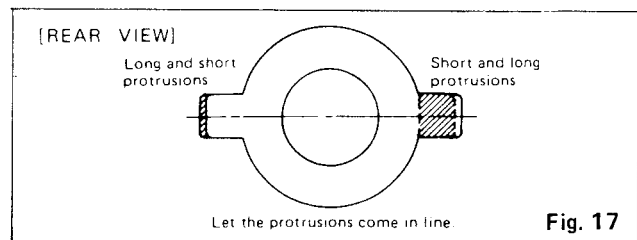

Fig. 17

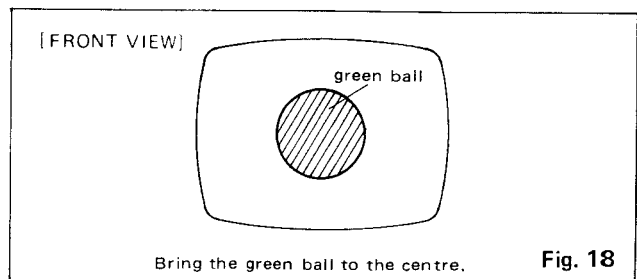

Fig. 18

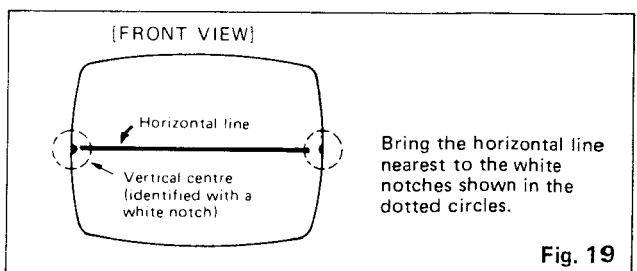

Fig. 19

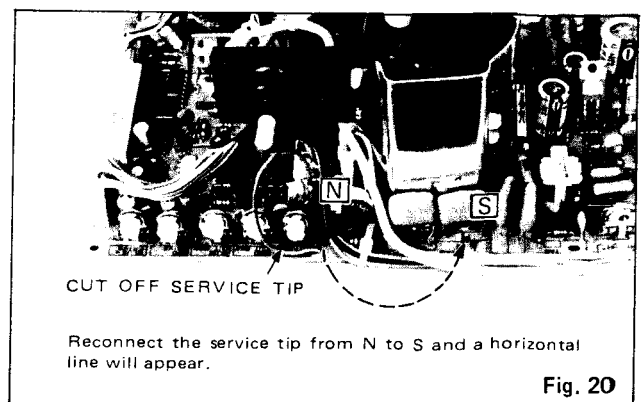

Fig. 20

ADJUSTING THE STATIC CONVERGENCE AND DYNAMIC CONVERGENCE

Static convergence is achieved by four magnets located on the neck, nearest the base of the picture tube. The front pair of magnet rings (closest to the purity tabs) are adjusted to converge the blue and red crosshatch lines. The rear pair of convergence rings (closest to the base of the picture tube) are adjusted to converge the magneta (R/B) and green crosshatch lines.

Dynamic convergence is achieved by tilting the deflection yoke, Up-Down and Left-Right.

1. Connect a crosshatch generator to the antenna terminals and adjust PICTURE control for a distinct pattern.
2. Adjust the convergence around the edges of the picture tube by tilting the yoke, up-down and left-right, and temporarily install one wedge at the top of the yoke. (Fig. 23, 24, 25.)
3. Rotate the front pair of tabs as a unit to minimize the separation of the red and blue lines around the center of the screen. Variation of the angle between the tabs adjust the convergence of red and blue.
4. Rotate the rear pair of tabs as a unit to minimize the separation of the magneta (R/B) and green lines. (Fig. 22.)
5. Adjust the spacing of the rear tabs to converge the magenta and green lines.
6. Remove the wedge installed temporarily on the yoke.
7. Tilting the angle of the yoke up, down and sideways, and adjust the yoke so as to obtain the circumference convergence. (Fig. 24, 25.)
8. Insert three wedges to the position as shown in Fig. 26 to obtain the best circumference convergence.
9. Wedge has a backing of both faces adhesive tape. Therefore, tearing off one side of adhesive tape, and fix the wedges.
10. Rotate the magnet locking ring to counterclockwise.

ADJUSTING THE WHITE BALANCE (Black and White Tracking)

1. Receive a black and white broadcast, or misadjust the Fine Tuning control (or Channel Tuning control) so that a color picture become black and white picture.
2. Set the red and blue drive controls for their mechanical center.
3. Turn the red, green and blue cut off controls and the screen control fully counterclockwise. (min.)
4. Change the service tip as shown in Fig. 20.
5. Turn screen control slowly clockwise until a very faint horizontal line appears.
6. Turn the cut off control of the color which has appeared first, clockwise by about 10° and then adjust the screen control again so that the color may shine faintly.
7. Turn the other color cut off controls slowly clockwise until a reasonable white line appears.
8. Return the service tip to normal position. (Fig. 20.)
9. Adjust the red and blue drive controls for best white highlights.

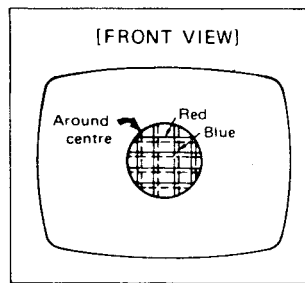

Fig. 21

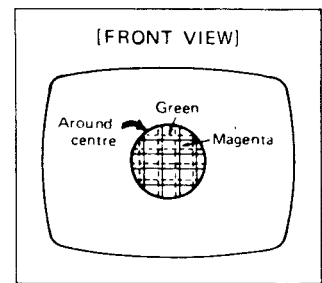

Fig. 22

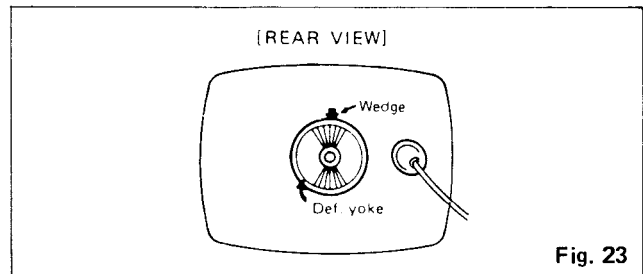

Fig. 23

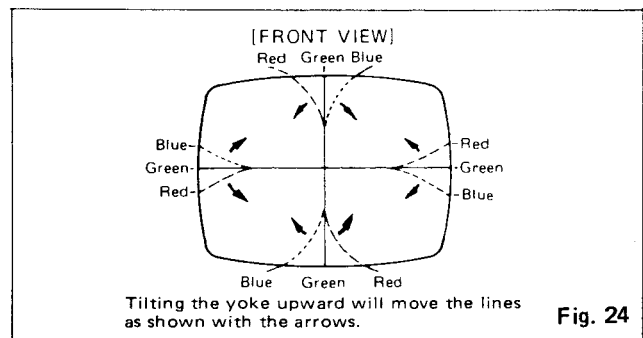

Fig. 24

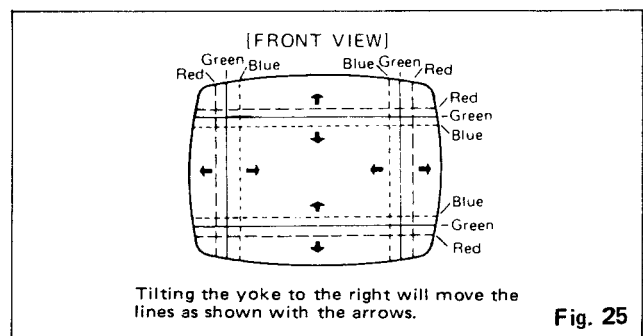

Fig. 25

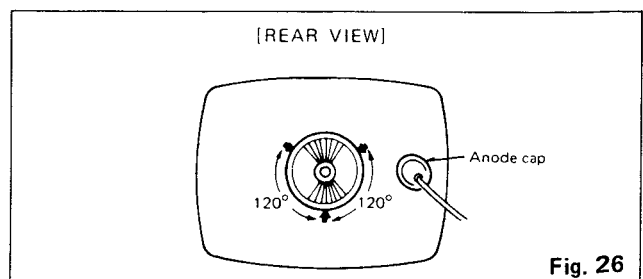

Fig. 26

6. ADJUSTMENT OF CASSETTE TAPE RECORDER UNIT

REPLACING THE HEADS

Should the following adjustment procedures be taken depending on visual and aural senses, be sure to conduct subsequent readjustment by using correct appliances.

Replacing the heads

1. Replace the recording heads by removing the two screws marked **(A)** and **(B)** in Fig. 27.
2. Replace the erasing heads by removing the two screws marked **(C)** and **(D)** in Fig. 27.
3. Adjust the screw position and play when reassembling, so that both heads fall within the allowance indicated in Fig. 27 when depressing the PLAY button.

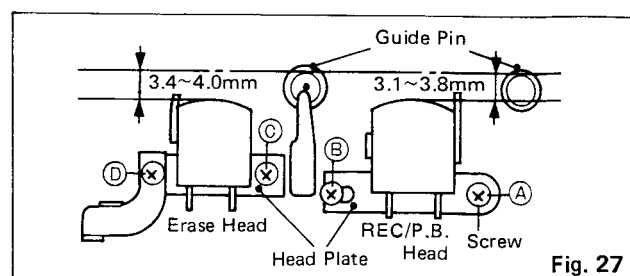

Fig. 27

ADJUSTING THE REC/P.B. HEAD ANGLE

1. Connect the vacuum tube volt meter to the speaker terminal.
2. Play a head angle adjusting tape (JVC Test Tape VTT651 or VTT652.).
3. By rotating screw **(B)** in Fig. 27, adjust so that the vacuum tube volt meter pointer indicates the maximum value.
4. After completing adjustment, paint-lock screw **(B)**.
5. When adjusting, without using a vacuum tube volt meter or a test tape, adjust the angle so that the speaker volume (especially in the high frequency area) can be maximized.

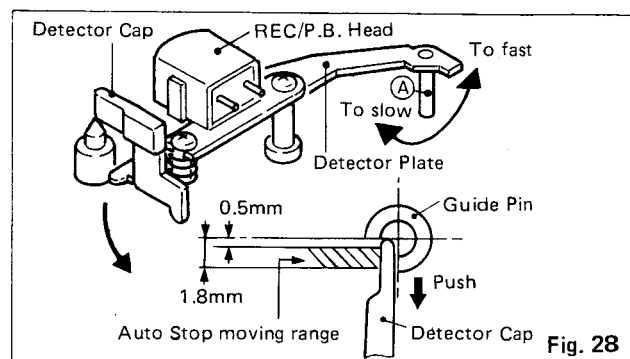

Fig. 28

ADJUSTING THE AUTO-STOP MECHANISM FUNCTIONING RANGE

Bend portion **(A)** of the detecting plate in Fig. 28 so that the autostop mechanism functions when causing the detecting cap top end to move by 0.5 - 1.8mm under a playing condition (namely, when a tape comes to an end after completing reproduction).

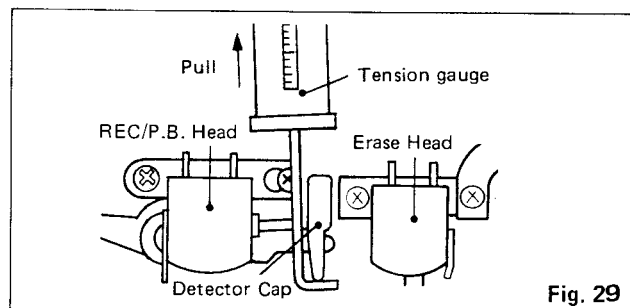

Fig. 29

ADJUSTING THE AUTOSTOP DETECTING PRESSURE

1. Start reproducing while placing the unit with the motor side down.
2. Adjust the regulating arm bend in Fig. 30 so that the autostop mechanism starts functioning between 45g and 65g when slowly pulling the cap with the tension gauge, as illustrated in Fig. 29.

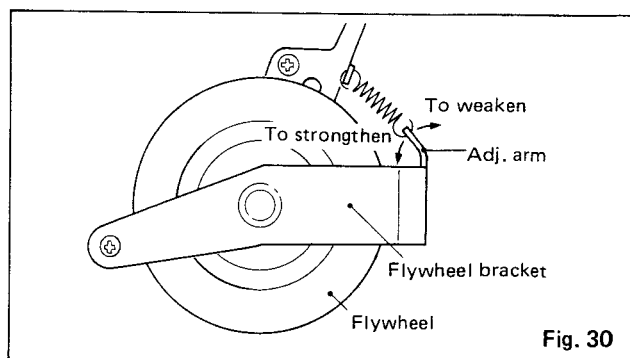

Fig. 30

ADJUSTING THE FLYWHEEL THRUST

Insert a thickness gauge between the flywheel and the flywheel bracket, and adjust the opening between 0.1 - 0.4mm by rotating screw **(A)** in Fig. 31.

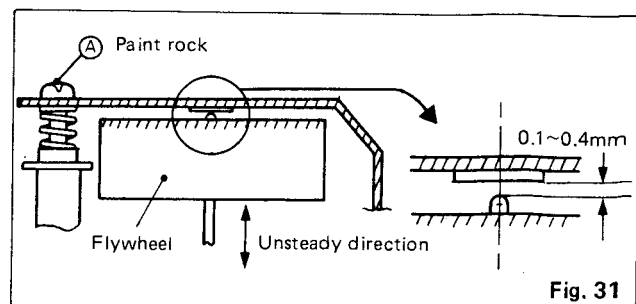

Fig. 31

CONFIRMING PAUSE FUNCTIONING AND ADJUSTING IT'S TIMING

● CONFIRMING THE FUNCTIONING AND TIMING

1. Confirm that, while depressing the PAUSE button while playing, the tape stops running and when depressing it again, the tape resumes playing without abnormality.
2. Confirm that when depressing the PAUSE button gently, the pinch roller first departs from the capstan and stops rotating, and then the reel disc stops. (Even if they stop almost concurrently, this is no sign of an abnormality).

< NOTE > We recommend employing a C-30 cassette tape or another one with less winding to ensure easy and reliable confirmation.

● ADJUSTING THE FUNCTIONING AND TIMING

1. Adjust the pinch arm lever bent portion ③ in Fig. 32 so that the distance between the pinch roller and the capstan are 0.5mm or more when depressing the PAUSE button.
2. Should the reel disc in the winding side stop rotating sooner than that on the feeding side while depressing the PAUSE button, thus allowing the tape to exit between the heads, bend pinch arm lever portion ③ in direction A.

< NOTE > Since bending the pinch arm lever influences cue and review procedures, confirm such function at the same time.

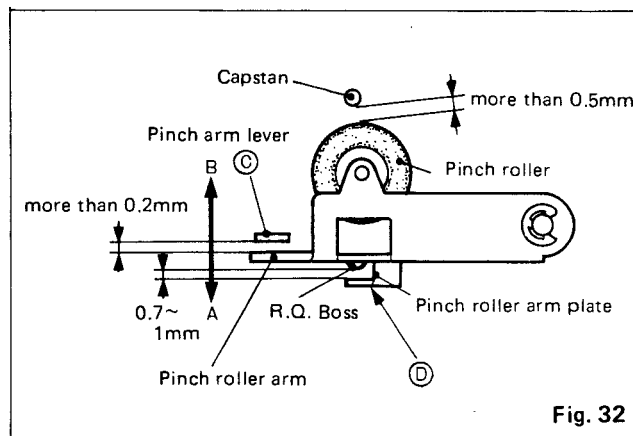

Fig. 32

CONFIRMING CUE/REVIEW FUNCTIONS AND ADJUSTING THEIR TIMING

● CONFIRMING THE FUNCTIONING AND TIMING

1. Confirm that when slowly depressing the CUE button while playing, the pinch roller stops first and then the winding reel disc stops, thus allowing the fast forwarding process to immediately follow. Also confirm that when slowly repressing the CUE button, reverse sequence is conducted.
2. Confirm that when slowly depressing the REVIEW button while playing, the pinch roller stops first and then the winding reel disc stops, thus allowing the rewinding process to immediately flow. Also confirm that when slowly repressing the REVIEW button, reverse sequence is conducted.

< NOTE > Even if both the pinch roller and the reel disc stop rotating almost at the same time, or a slight fast-forwarding process is detected, this is no sign of an abnormality.

● ADJUSTING THE CUE/REVIEW TIMING

1. Should the tape exit between the heads when starting to cue or review, bend pinch arm lever portion ③ in Fig. 32 in the A direction.
2. Should abnormal fast-forwarding be detected when starting to cue or review, bend pinch arm lever portion ③ in Fig. 32 in the B direction.
3. After completing adjustment, depress the REWIND button while recording (namely, with both the RECORD and PLAY buttons depressed) and confirm that a distance exceeding 0.2mm exists between the pinch arm lever and the pinch roller arm. Adjust bending of portion ④ in Fig. 32 so that the distance between the RQ boss and the pinch roller arm plate is 0.7 to 1.0mm when depressing the PLAY button.

< NOTE > Since bending of the pinch arm lever exerts an influence on cue and review procedures, confirm such functions concurrently.

ADJUSTING PRESSURE-FITTING OF THE PINCH ROLLER

1. Confirm that the pinch roller stops rotating between 450 - 550g on the tension gauge indicator when slowly pulling the gauge hooked at the pinch roller arm as shown in Fig. 33 while playing and placing the unit with the motor side down.
2. Should the roller not stop rotating, replace the pressure-fitting spring or bend it until the roller stops rotating between the above-mentioned range.

< NOTE > Should the pressure-fitting spring be excessively strong, noise produced by the pinch roller bearing or extreme wow and flutter may result. Should it be excessively weak, auto stop may malfunction or wow and flutter may be increased.

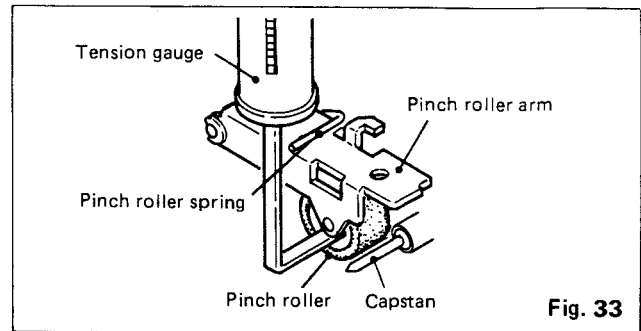

Fig. 33

ADJUSTING THE PLAYING TORQUE

1. Confirm that the playing torque is 40 - 70 g.cm while playing, when measuring it by applying a torque gauge to the winding reel disc.
2. Should playing torque exceed this range, check whether or not rubber parts and rotating parts are smeared with dust or oily substances. Should the torque be below this range, lift the clutch spring plate to position ③ in Fig. 34; should it be above the range, lower the plate to position ①.

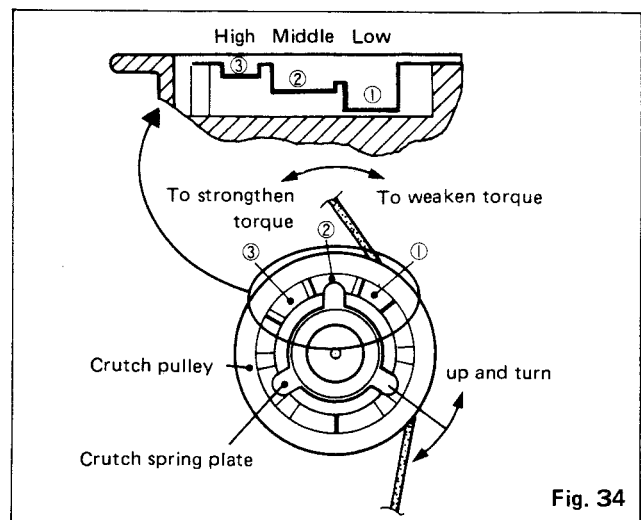

Fig. 34

ADJUSTING THE FAST FORWARDING TORQUE

By applying a torque gauge to the winding reel disc, confirm that fast forward torque falls between the 60 - 150 g.cm while fast forwarding. (Fig. 35)

1. When normal torque is unobtainable due to unstable pressure-fitting between the FF idler and the flywheel, or due to an unstable sliding mechanism in the FF idler, bend the FF button lever portion ③ in direction A or move the clutch spring plate in the FF idler in direction ①.
2. When normal torque is unobtainable even when the sliding mechanism in the FF idler functions normally, move the clutch spring plate in the FF idler in direction ④.

ADJUSTING THE REWINDING TORQUE

By applying a torque gauge to the winding reel disc, confirm that the rewinding torque falls between 60 - 150 g.cm while rewinding. (Fig. 35)

1. When normal torque cannot be obtained due to unstable pressure fitting between the FF idler and the flywheel, or due to an unstable sliding mechanism in the FF idler, bend the REWIND button lever portion ④ in direction B, or move the clutch spring plate in the FF idler in direction ①.
2. When normal torque cannot be obtained even when the sliding mechanism in the FF idler functions normally, move the clutch spring plate in the FF idler in direction ④.

< NOTE > If rubber parts such as belts and idlers or the flywheel peripheral surfaces are smeared with dust or oily substance, normal torque cannot be ensured in certain instances. Clean them with alcohol.

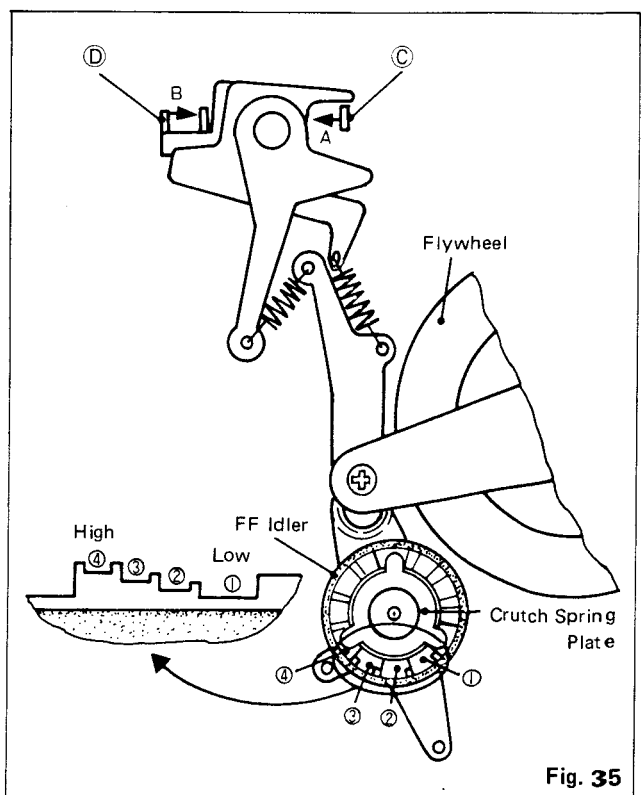

Fig. 35

7. SERVICING GUIDE FOR CASSETTE TAPE RECORDER UNIT

DETERIORATING SOUND IN PLAYBACK

1. Check the REC/BP head if it is attached to dirt or dust.
2. Check the REC/BP head if it is weared off.
If so, the response will be bad in high frequency range.
3. Check that the wirings are broken and all transistors are correctly operated.

CRASH SOUND IN RECORDING

When you make the playback of the recorded Demo cassette tape, the tone quality is clear.

But when you make the playback of the cassette tape which recorded with normal blank tape, the tone quality is bad.

In this case check as followings.

1. Make monitoring of the recording sound with a ear-phone.
2. If bad on step 1, make the checking of the broken wirings and all the transistors.
3. If OK on step 2, make the checking of the recording bias oscillator circuit.

WOW-FLATTER

Check as followings in increased wow and flutter.

Causes	Symptoms	Servicing
Capstan of Flywheel	<ul style="list-style-type: none"> · The capstan shaft deflection · Heavy rotation of the flywheel 	<ul style="list-style-type: none"> · Replace the flywheel · Adjust the flywheel thrust · Oiling to or cleaning up the flywheel
Pinch-roller	<ul style="list-style-type: none"> · Tough rotation · Inaccurate angle for the capstan · Non-sticking pressure to the tape 	<ul style="list-style-type: none"> · Replace the pinch-roller · Clean up the pinch-roller · Make the pinch-roller in parallel with the capstan · Replace or readjust the spring
Belt	<ul style="list-style-type: none"> · Dirty belt · Slipping belt 	<ul style="list-style-type: none"> · Replace or clean up the belt
Back-Tension	<ul style="list-style-type: none"> · Rough back-tension 	<ul style="list-style-type: none"> · Replace or oil to the back-tension spring
Motor	<ul style="list-style-type: none"> · The motor shaft deflection · The motor pulley dirt · The pulley swing 	<ul style="list-style-type: none"> · Replace or clean up the motor shaft · Replace the take-up idler ass'y

REWINDING FAULTS

Causes	Symptoms	Servicing
In Play Mode	<ul style="list-style-type: none"> · Slipping between the take-up idler and the reel base · The take-up idler · Slipping between the take-up idler and the capstan belt 	<ul style="list-style-type: none"> · Replace or readjust the take-up idler spring · Clean up rubber parts of the reel base · Replace or clean up the capstan belt
In Cue Mode	<ul style="list-style-type: none"> · The FF idler slipping · The FF idler · The capstan belt slipping 	<ul style="list-style-type: none"> · Clean up rubber parts of the idler · Replace or readjust the spring · Replace idler · Replace or clean up the capstan belt
In review Mode	<ul style="list-style-type: none"> · The REW idler or the FF idler slipping · The FF idler · Capstan belt slipping 	<ul style="list-style-type: none"> · Clean rubber parts of idler · Replace or readjust the spring · Replace idler · Replace or clean up the capstan belt

NOISES

Causes	Symptoms	Servicing
Noises in Play Mode	<ul style="list-style-type: none"> - Noises from the take-up idler - Noises from the rotating parts 	<ul style="list-style-type: none"> - Replace the take-up idler - Lubricate to the rotating parts
Noises in Cue or REW Mode	<ul style="list-style-type: none"> - Noises from the FF idler - Noise from the REW idler 	<ul style="list-style-type: none"> - Lubricate to or replace the idler
Motor Noises	<ul style="list-style-type: none"> - Noises from the motor 	<ul style="list-style-type: none"> - Replace the motor

CLEANING

Be sure to clean up the heads, capstan, pinch roller and other parts which come into contact with the tape with cotton stick in a little alcohol.

The dirty heads will deteriorate the sound quality and also cannot erase a recorded tape.

OILING

Make oiling 1~2 drops to the reel disc, pinch roller and rewind idler bearings 1~3 times in a year.

If, however, oiling to too much, it will scatter the oil to the surrounding parts and then may cause the rough rotating.

8. ALIGNMENT BY MEANS INSTRUMENTS

PRIOR TO ALIGNMENT

1. Alignment can be conducted by employing the printed circuit board only when a separate power source is available. Otherwise, connect the power cord to AC 240V, 220 – 200V, 127V or 110V after setting the voltage selector to proper position.
2. Warm up both the measuring instruments and the set for more than 10 minutes prior to proceeding with alignment.
3. Employ a thick ground cable between measuring instruments.
4. After connecting the ground cable to the power source, apply power to the 10.5V power source and the bias power in that order. Follow this order in reverse when disconnecting the power source.
5. Avoid using metallic rods for aligning.
6. Apply low-impedance power for the bias power; otherwise, correct waveforms cannot be obtained. (Should a high-impedance power be employed, add the below-mentioned circuit to the present ones.)
7. Prior to proceeding with alignment, be sure to confirm that a marker signal is being emitted.

INSTRUMENTS AND CONNECTION FOR ALIGNMENT OF COLOR TV UNIT

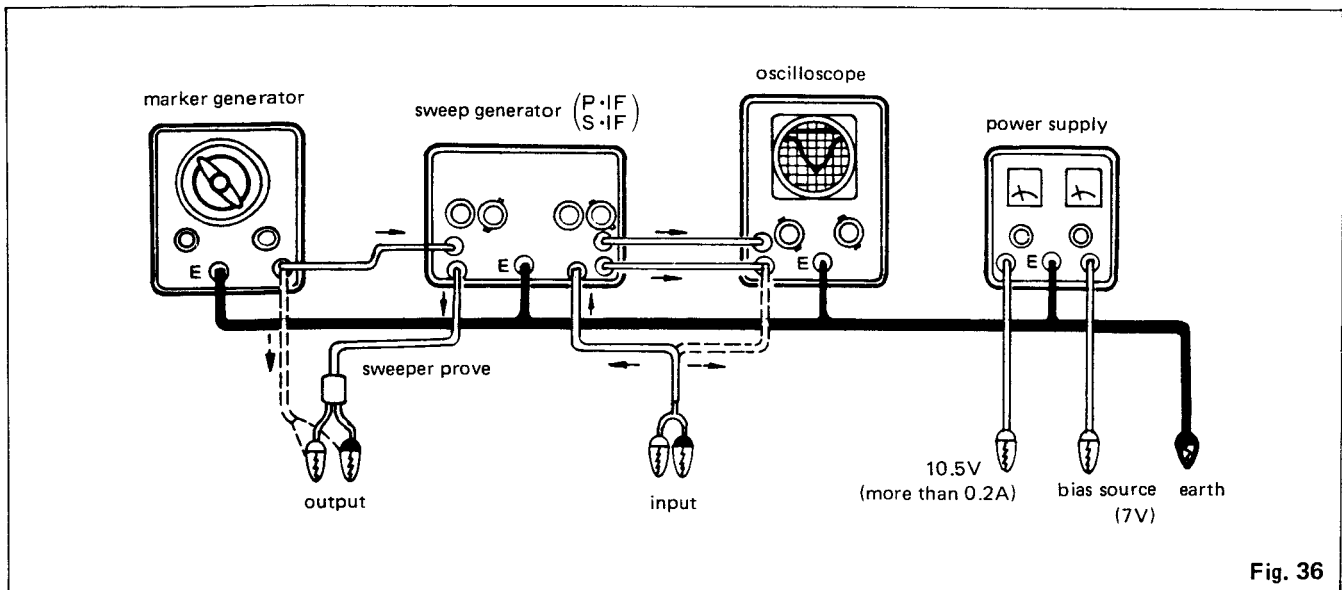

Fig. 36

SWEOPER PROBE

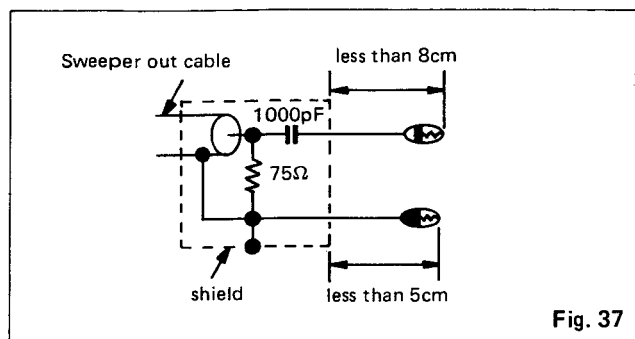

Fig. 37

CIRCUIT FOR HIGH-IMPEDANCE

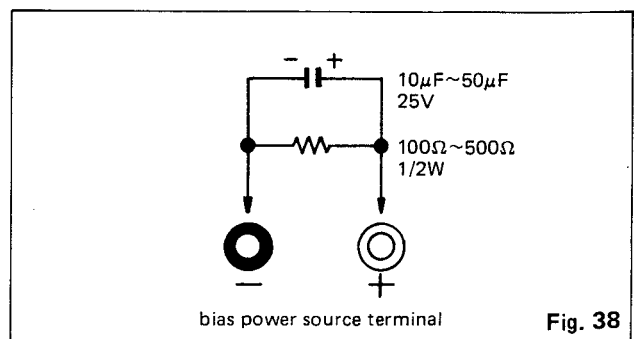

Fig. 38

TEST-POINTS AND ALIGNMENT LOCATION ON THE COLOR TV P.C. BOARD

The Face

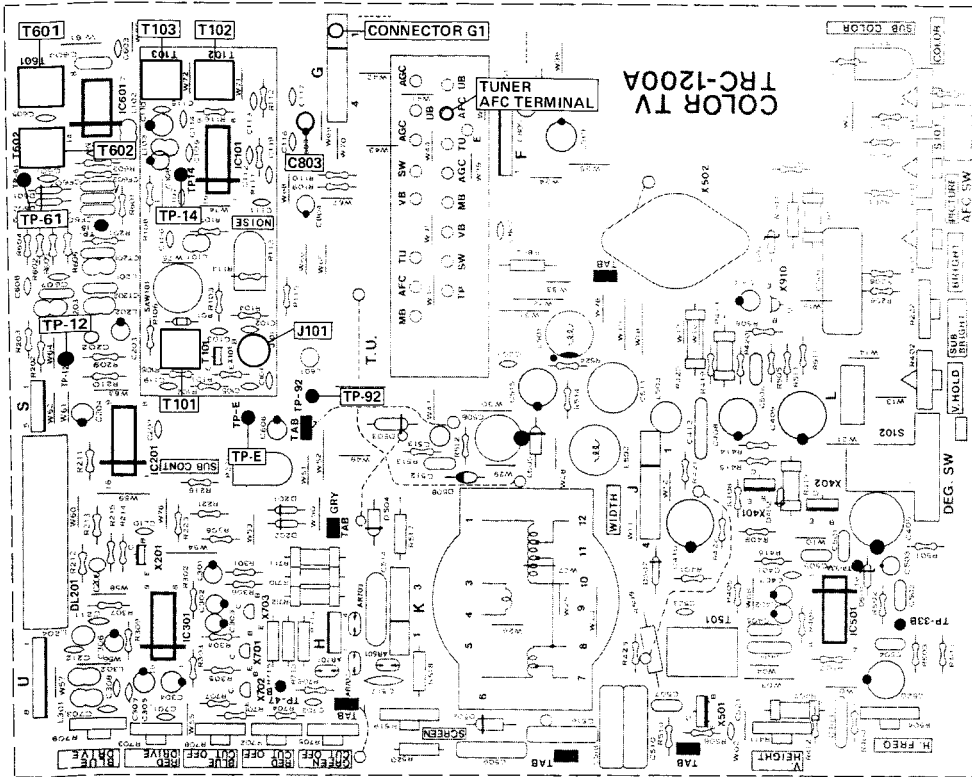
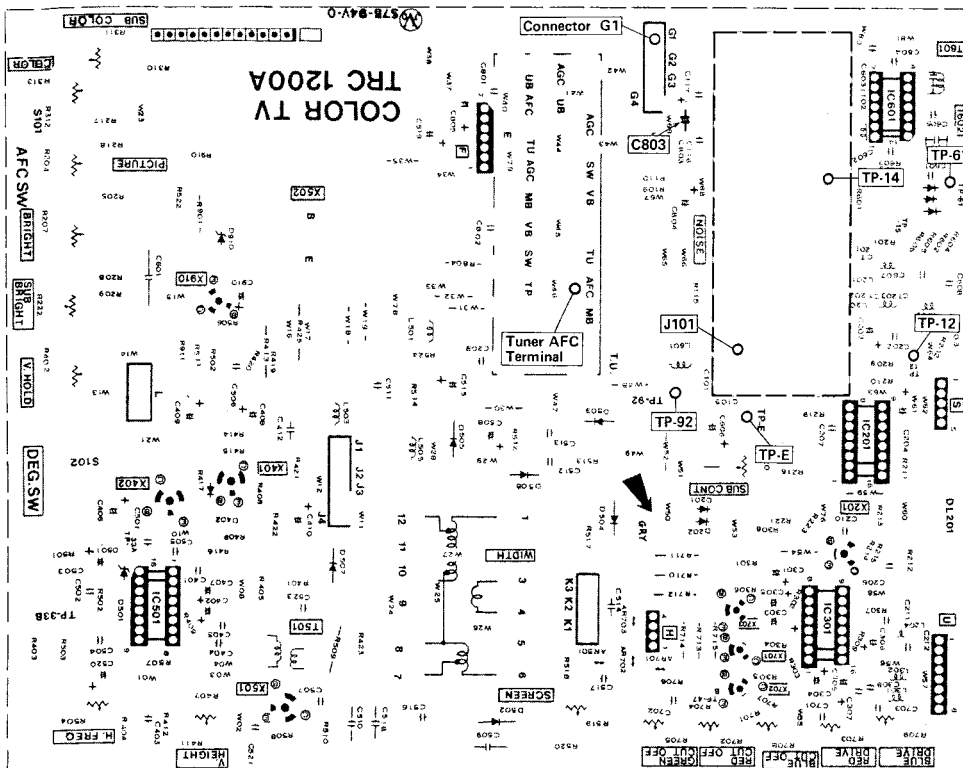

Fig. 42

The Back Side



ALIGNING THE COLOR TV UNIT

● ALIGNING THE P.IF

■ CONNECTION AND OTHER PRELIMINARY PROCEDURES

Sweeper probe output terminal	Oscilloscope input terminal	Power source	Bias power source	Others
J101	TP-12	TP-92	TP-14	

1. After connecting the cables as shown above (removing the pin plug from the J101 tuner), set the sweep generator to the P.IF band position.
2. By adjusting the sweep generator output, set the P.IF waveform to 0.3V.

■ ALIGNMENT

1. Align the 34.47MHz marker with 0.23V, the 38.9MHz marker with 0.21V by alternately rotating cores T101 and T102 (see Fig. 44).
2. Realign the sweep generator output to produce a P.IF waveform; then confirm that the value of each marker is equal to that shown in Fig. 44.

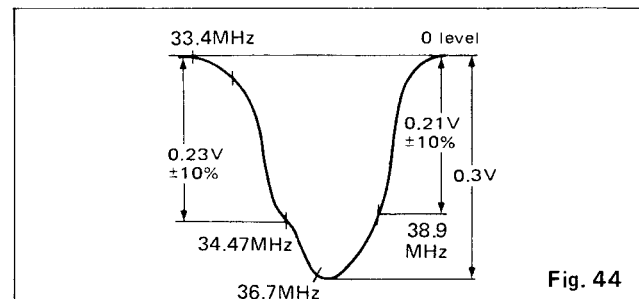

Fig. 44

● ALIGNING THE RF.AFC

■ CONNECTION AND PRELIMINARY PROCEDURES

Sweeper probe output terminal	Oscilloscope input terminal	Power source	Bias power source	Others
J101	TP-12 ↓ Tuner AFC terminal	TP-92	TP-14	Disconnect C803

1. After connecting the cables as shown above and confirming that the correct waveform exists, connect the oscilloscope input terminal to the tuner AFC terminal (see Fig. 44.)
2. Turn on the automatic fine-adjustment switch.
3. By disconnecting C803, an S-curve is observable. Align both the oscilloscope voltage shaft and the sweep generator output to optimize the S-curve.

■ ALIGNMENT

1. By rotating the T103 core, align the 38.9MHz marker with the center of the S-curve.
2. Realign the T103 so that the 38.9MHz marker DC level becomes 6.0V (see Fig. 46).
3. Connect the C803.

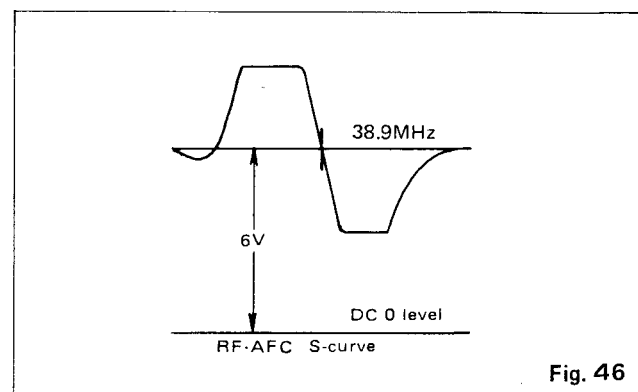

Fig. 46

● **ALIGNING THE S.IF**
 ■ **CONNECTION AND PRELIMINARY PROCEDURES**

Sweeper probe output terminal	Oscilloscope input terminal	Power source	Bias power source	Others
TP-61	Connector G1	TP-92	TP-14	

1. After connecting the cables as shown above, set the sweep generator to the S.IF band position.
2. Increase the sweep generator output to obtain three S-curves as illustrated in Fig. 47.

■ **ALIGNMENT**

1. By rotating the T601 core, align the 5.5MHz and 6MHz markers with the each center of the 1st and 2nd S-curves, respectively.
2. By rotating the T602 core, align the 6.5MHz marker with the center of the 3rd S-curve.
3. Repeat procedures 1 – 2 (above) until optional alignment is attained.

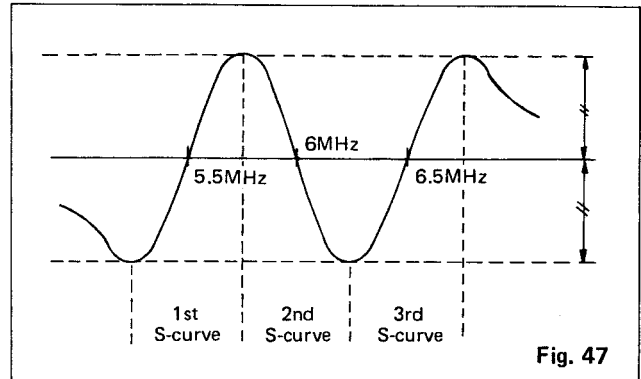

Fig. 47

ALIGNMENT OF RADIO AND AMPLIFIER

● **ALIGNING THE RECORDING BIAS**

■ **CONNECTION AND PRELIMINARY PROCEDURES**

1. This aligning procedure is conducted while operating the recording unit (namely, when depressing both the recording and reproducing push buttons).
2. Connect both the frequency counter and the millivolt meter to the connector P3.
3. Set the beat cut switch to the position marked with a point (.).

■ **ALIGNMENT**

1. Rotate the T901 core so that the frequency counter indicates 48KHz.
2. Rotate the recording bias volume (R925) so that the millivolt meter indicates 7mV.
3. Repeat procedures 1 and 2 (above) until optimal conditions are reached.
4. After setting the beat cut switch to the position marked with a colon (:), confirm that frequency counter indicates 47KHz or less.

● **ALIGNING THE AM (MW and LW) IF**
 ■ **CONNECTION AND PRELIMINARY PROCEDURES**

Sweeper probe output terminal	Oscilloscope input terminal	Power source	Bias power source	Others
TP-803 (VC trimmer terminal)	TP-802	Connector A2		

1. Set the radio tuning dial to anywhere in the higher frequency range in which no radio signals can be received.
2. Should no AM,IF waveform be observed, adjust the IC bias VR (R838) until it is observed.
3. Align both the sweep generator output and the oscilloscope voltage shaft to obtain an ideal waveform.

■ **ALIGNMENT**

1. By rotating the T803 and the T804 alternately, align the 455KHz marker until it is maximized and becomes vertically symmetrical in waveform (see Fig. 49).
2. The 455KHz marker does not always fall in the center when it is maximized, since the IF circuit incorporates a ceramic filter. In this instance, align

the marker so that the waveform is maximized irrespective of its dislocation from the center.

3. By rotating the IC via VR (R838), realign the waveform until it becomes maximized.

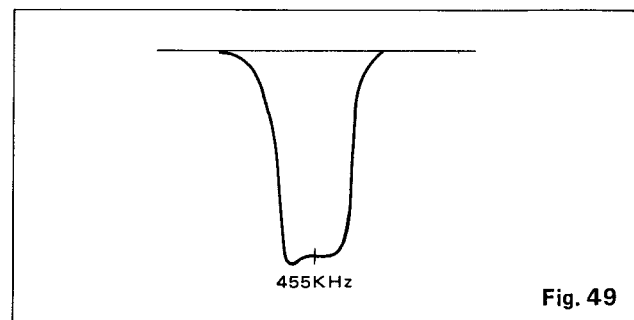

Fig. 49

● **ALIGNING THE FM IF**
 ■ **CONNECTION AND PRELIMINARY PROCEDURES**

Sweeper probe output terminal	Oscilloscope input terminal	Power source	Bias power source	Others
TP-801	TP-802	Connector A2		

1. Change over the band change-over switch to the FM position.
2. Set the radio tuning dial to anywhere in the higher frequency range in which no FM radio signals can be received.

■ **ALIGNMENT**

1. After obtaining an S-curve such as shown in Fig. 50 by rotating the T808 core, continue rotating it until the 10.7MHz marker arrives at the top of the waveform, as illustrated in Fig. 51.
2. By rotating cores T801, T805, and T807 alternately, obtain the maximized waveform which is vertically symmetrical and of which the 10.7MHz marker exists at the center (see Fig. 51).
3. The 10.7MHz marker does not always fall in the center of the waveform when it is maximized, since the IF circuit incorporates a ceramic filter. In this instance, align the marker so that the waveform is maximized irrespective of its dislocation from the center.
4. Rotate the T808 core again to obtain an S-curve which is vertically symmetrical and widest in oscillation width. (see Fig. 50)
5. Again rotate cores T801, T805, and T807 to fine-adjust the S-curve, so that its oscillation width becomes maximized.

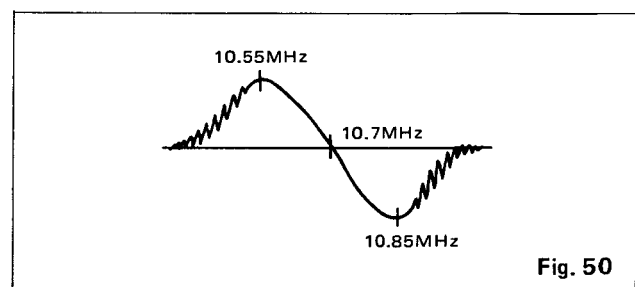

Fig. 50

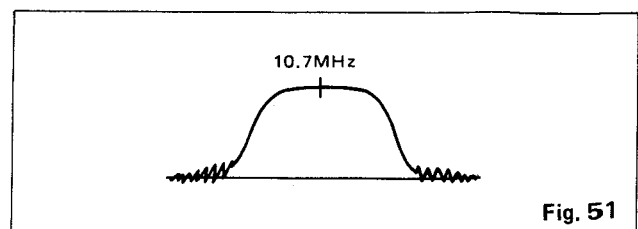

Fig. 51

● **ALIGNING THE AM (MW and LW) TRACKING**

■ **CONNECTION AND PRELIMINARY PROCEDURES**

Signal generator output terminal	Oscilloscope V.T.V.M	Power source (+10.5V)	Bias power source	Others
Test loop antenna	TP-802	Connector A2	/	Test loop antenna should be vertical to, and about 60cm apart from, the bar antenna.

1. Set the oscilloscope voltage shaft sensitivity to about 10mV/cm, and align the signal generator output so that waveforms on the oscilloscope may be easily observed.

■ **ALIGNMENT**

Aligning order	Signal generator frequency	Radio dial position	Item to be manipulated	Aligning procedures
1	500KHz (145KHz)	Minimal frequency	T802 (T809)	Conduct alignment so that the vacuum tube voltage meter indicates the maximal value. Confirm that the oscilloscope waveform is not saturated.
2	1650KHz (360KHz)	Maximal frequency	C825 (C884)	
3	Repeat both items 1 and 2 (above)			
4	620KHz (160KHz)	Synchronize to 620KHz	T810(T811)(Align the bar antenna coil)	
5	1400KHz (350KHz)	Synchronize to 1400KHz	C821 (C881)	
6	Repeat both 4 and 5			
7	After completing alignment, insert a wedge into the bar antenna coil and secure it with wax.			

() for LW alignment

● **ALIGNING THE FM TRACKING**

■ **CONNECTION AND PRELIMINARY PROCEDURES**

Signal generator output terminal	Oscilloscope V.T.V.M	Power source (+10.5V)	Bias power source	Others
FM antenna terminal via 1000pF	TP-802	Connector A2	/	/

1. Set the radio band change-over switch to the FM position.
2. Set the oscilloscope voltage shaft sensitivity to about 10mF/cm, and align the signal generator output so that waveforms on the oscilloscope can be easily observed.

■ **ALIGNMENT**

Aligning order	Signal generator frequency	Radio dial position	Item to be manipulated	Aligning procedures
1	87.5MHz	Minimal frequency	L803 (Stretch and shorten the coil)	After completing alignment, insert a wedge into the bar antenna coil and secure it with wax.
2	109MHz	Maximal frequency	C812	
3	Repeat both items 1 and 2 (above)			
4	88MHz	Synchronize to 88MHz	L801	
5	108MHz	Synchronize to 108MHz	C803	
6	Repeat both 4 and 5			

9. REPLACEMENT PARTS LIST

PRODUCT SAFETY NOTE

Components identified by the  symbol in the PARTS LIST and the shaded areas on the Schematic have special characteristics important to safety. Before replacing any of these components read carefully the **SAFETY PRECAUTION** on Page 2 of this Service Manual. **DO NOT** degrade the safety of the set through improper servicing.

RESISTOR

All resistance values are in ohms.

K : 1,000 M : 1,000,000

C R	: Carbon Resistor
Comp. R	: Composition Resistor
OM R	: Oxide Metal Film Resistor
V R	: Variable Resistor
MF R	: Metal Film Resistor
CMF R	: Coating Metal Film Resistor
UNF R	: Nonflammable Resistor
F R	: Fusible Resistor

CAPACITOR

Capacitance values are in pF or in μ F.

C Cap.	: Ceramic Capacitor
M Cap.	: Mylar Capacitor
E Cap.	: Electrolytic Capacitor
BP E Cap.	: Bi-Polar (or Non-Polar) Electrolytic Capacitor
MM Cap.	: Metalized Mylar Capacitor
PP Cap.	: Polypropylene Capacitor
MPP Cap.	: Metalized PP Capacitor
PS Cap.	: Polystyrol Capacitor
Tan. Cap.	: Tantal Capacitor

Tolerances are as follows.

M: $\pm 20\%$ K: $\pm 10\%$ J: $\pm 5\%$

Note—1: When ordering replacement parts please specify the part number as shown in this list including part name, identification number and model number. Complete information will help expedite the order.

Use of substitute replacement parts which do not have the same safety characteristics as specified, may create shock, fire, or other hazards. For maximum reliability and performance, all parts should be replaced by those having identical specifications.

Note—2: 1/4 Watt carbon resistors and 50 Volt ceramic capacitors of standard electrical components are omitted from this PARTS LIST. Each part number of these standard replacement components is defined as follows. Only by way of suggestion.

- Carbon Resistor (1/4W, $\pm 5\%$ Tolerance)

QRD141J —

CONSTANT TERM.

- Ceramic Capacitor (50 Volts, $\pm 5\%$ Tolerance)

QCS11HJ —

CONSTANT TERM.

—	<input type="text"/>	<input type="text"/>	<input type="text"/>	
	↑	↑	↑	
1	R	0	→	1.0 Ω
2	R	7	→	2.7 Ω
9	R	0	→	9.0 Ω

1	0	<input type="text"/>	(Example)
1	2	<input type="text"/>	12 <input type="text"/> means 12 x 10 ^{<input type="text"/>}
1	5	<input type="text"/>	
1	8	<input type="text"/>	<input type="text"/> 0 to 5
2	2	<input type="text"/>	
2	7	<input type="text"/>	
3	3	<input type="text"/>	
3	9	<input type="text"/>	
4	7	<input type="text"/>	
5	6	<input type="text"/>	
6	8	<input type="text"/>	
8	2	<input type="text"/>	

(For example)

- Carbon Resistors (1/4W, $\pm 5\%$ Tolerance)

2.7 Ω → QRD141J-2R7

47 k Ω → 47 x 10³ → QRD141J-473

- Ceramic Capacitors (50 Volts, $\pm 5\%$ Tolerance)

5pF → QCS11HJ-5R0

180pF → 18 x 10¹ → QCS11HJ-181

680pF → 68 x 10¹ → QCS11HJ-681

TRC-1200A (COLOR TV P. B. ASS'Y) PARTS LIST

Symbol No.	Parts No.	Rating	Parts Name	Symbol No.	Parts No.	Rating	Parts Name
R1113	QVP5A0B-014	10kΩ	VR (Noise)	C1402	QEE51CK-225	2.2μF 16V K	Tan. Cap.
1204	QVG8A3B-014	10kΩ	" (Picture)	1403	QFM41HK-563	0.056μF 50V K	M Cap.
1207	QVG8A3B-152	500Ω	" (Brightness)	1404	QFM41HK-104	0.1μF " "	"
1220	QVP5A0B-023	2kΩ	" (Sub Contrast)	1405	QFM41HK-393	0.039μF " "	"
1222	QVZ3234-023	2kΩ	" (Sub Bright)	1406	QEW41CA-227	220μF 16V +50% -10%	E Cap.
1311	QVP5A0B-024	20kΩ	" (Sub Color)	1407	QEE51CK-106	10μF 16V K	Tan. Cap.
1312	QVG8A3B-123	12kΩ	" (Color)	1408	QEW41CA-107	100μF 16V +50% -10%	E Cap.
1402	QVG8A3B-053	5kΩ	" (V. Hold)	1409	QEW41EA-477	470μF 25V +50% -10%	"
1407	QRX016J-3R3	3.3Ω 1W J	CMF R	1410	QEW41CA-477	470μF 16V +50% -10%	"
1411	QVZ3230-022	200Ω 0.3W ±30%	VR (V. Height)	1412	QFM41HK-224	0.22μF 50V K	M Cap.
1413	QRG026J-680	68Ω 2W J	OM R	1501	QFM41HK-102	0.001μF " "	"
1417	QRX016J-3R9	3.9Ω 1W J	CMF R	1502	QFM41HK-153	0.015μF " "	"
1425	QRG026J-680	68Ω 2W J	OM R	1503	QEW41HA-105	1μF 50V +75% -10%	E Cap.
1503	△QRV142F-1182	11.8kΩ ¼W ±1%	CMF R	1504	QFP11HJ-562	0.0056μF 50V J	PP Cap.
1504	QVZ3230-053	5kΩ 0.3W ±3%	VR (H. Hold)	1505	QFM41HK-223	0.022μF 50V K	M Cap.
1509	QRG026J-330	33Ω 2W J	OM R	1506	QFM41HK-333	0.033μF " "	"
1518	QRC121K-474	470kΩ ½W K	Comp. R	1507	QFM41HK-183	0.018μF " "	"
1519	QVZ3218-026G	2MΩ ½W N	VR (Screen)	1508	QEW41CA-477	470μF 16V +50% -10%	E Cap.
1520	QRC121K-684	680kΩ ½W K	Comp. R	1509, 10	△AX49316-223	0.022μF 400V	PP Cap.
1522	QRG026J-221	220Ω 2W J	OM R	1511	AX49290		BP E Cap.
1525	△AX49449-33	33Ω	Fusible R	1512	QFM41HK-473	0.047μF 50V K	M Cap.
1702	QVZ3234-053	5kΩ	VR (R. Cutoff)	1513	QEN51HA-105	1μF 50V K	BP E Cap.
1703	QVZ3234-052	500Ω	" (R. Drive)	1514	QFH63BK-223	0.022μF 1.25KV K	MPP Cap.
1705	QVZ3234-053	5kΩ	" (G. Cutoff)	1515	QEW52CA-475	4.7μF 160V +75% -10%	E Cap.
1708	QVZ3234-053	5kΩ	" (B. Cutoff)	1516	△AX49316-223	0.022μF 400V	PP Cap.
1709	QVZ3234-052	500Ω	" (B. Drive)	1517	QCZ9001-102	0.001μF AC150V K	C Cap.
1710 ~12	QRG016J-123	12kΩ 1W J	OM R	1518	△AX49316-223	0.022μF 400V	PP Cap.
1713	QRC121K-562	5.6kΩ ½W K	Comp. R	1519	QEW41EA-477	470μF 25V +50% -10%	E Cap.
1714	QRC121K-562	5.6kΩ " "	"	1520	QEW41CA-107	100μF 16V +50% -10%	"
1715	QRC121K-562	5.6kΩ " "	"	1521	QCY12HK-471	470pF 500V K	C Cap.
1804	QRC121K-393	39kΩ " "	"	1522	△QCY12HK-102	1000pF 500V K	"
1901	QRC121K-473	47kΩ " "	"	1523	QCF11HP-103	0.01μF 50V +100% -10%	C Cap.
C1101	QCF11EZ-202	0.002μF 25V +80% -20%	C Cap.	1524	QEW41EA-107	100μF 25V +50% -10%	E Cap.
1102	QCF11EZ-502	0.005μF " "	"	1601	QCY12HK-102	1000pF 500V K	C Cap.
1103, 4	QCF11EZ-202	0.002μF " "	"	1602	QCF11EZ-503	0.05μF 25V +80% -20%	"
1106, 7	QCF11EZ-202	0.002μF " "	"	1603	QCF11EZ-103	0.01μF " "	"
1108	QEE51VM-474	0.47μF 25V M	Tan. Cap.	1604	QFM41HK-153	0.015μF 50V K	M Cap.
1109	QCF11EZ-202	0.002μF 25V +80% -20%	C Cap.	1605	QCT05CH-150	15pF 50V J	C Cap.
1110	QEW41CA-476	47μF 16V +50% -10%	E Cap.	1606	QEW41CA-227	220μF 16V +50% -10%	E Cap.
1111 ~13	QCF11EZ-202	0.002μF 25V +80% -20%	C Cap.	1607, 8	QCF11EZ-103	0.01μF 25V +80% -20%	C Cap.
1115	QCT05CH-121	120pF 50V J	"	1701 ~3	QCY12HK-681	680pF 500V K	C Cap.
1116 ~19	QCF11EZ-202	0.002μF 25V +80% -20%	"	1801, 2	QCF11EZ-102	0.001μF 25V +80% -20%	"
1202	QEN41CM-106	10μF 16V M	BP E Cap.	1803, 4	QEW41HA-105	1μF 50V +100% -10%	E Cap.
1203	QEW41CA-335	3.3μF 16V +75% -10%	E Cap.	1805	QEW41HA-474	0.47μF 50V "	"
1204	QEE51VM-474	0.47μF 25V M	Tan. Cap.	1901	AX49291		MPP Cap.
1206	QEN51HM-335	3.3μF 50V M	BP E Cap.				
1211	QCY12HK-681	680pF 500V K	C Cap.				
1301 ~3	QEW41HA-105	1μF 50V +100% -10%	E Cap.				
1304 ~6	QEW41CA-106	10μF 16V +100% -10%	E Cap.				
1401	QCY11HK-681	680pF 50V K	C Cap.				

Symbol No.	Parts No.	Rating	Parts Name	Symbol No.	Parts No.	Rating	Parts Name
1910	QEW50JA-107	100 μ F 6.3V $\begin{matrix} +50\% \\ -10\% \end{matrix}$	E Cap.	S1101	QSS1201-001		Slide Switch
L1101	A04725-1R8	1.8 μ H	Peaking Coil	1102	AX49292		Push Switch
L1102	A04872-80	80 μ H	"	DL1201	A76140		Delay Line
1103	A04872-80	80 μ H	"	AR1501	A75880		Air Cap
1201	A04725-8.2	8.2 μ H	"	701	A75880		"
~3				~3			
1204	A49468-562	5.6mH	"	SA1101	A76089		Saw Filter
1301,	A04725-220	220 μ H	"	P1101	A75087		Piezonator
2				CT1201	A76137		C Trap
1501	A75758		Linearity Coil	1202	A76138		"
1502	A75759		Width Coil	1203	A76139		"
1503	A49468-101	100 μ H	Peaking Coil	CF1601	A75088-C		Ceramic Filter
1504	A76246	Choke Coil	Peaking Coil	1602	A75417-C		"
1601	A49468-101	100 μ H	"	1603	A75111-C		"
1602	A04725-15	15 μ H	"				
T1101	A76133		1st Pif Transf.				
1102	A76134		Cw Transf.				
1103	A75964		AFC Transf.				
1501	A75757		H Drive Transf.				
1601	A76135		Sif Transf.				
1602	A76136		"				
D1201,	1S2473H-Y		Si. Diode				
2							
1402	1S2076A		Si. Diode				
1501	RD9.1EB		Zener Diode				
1502	V19-E		Si. Diode				
1503	1S2076A		"				
1504	UF-01		"				
1505,	V09-E		"				
7							
1508	V06-C		"				
1601	1S2473H-Y		"				
~3							
1910	RD12EB3		Zener Diode				
X1101	2SC1906	HITACHI Pc=300mW f _T =1000MHz	Transistor				
1201	2SA673 ©	HITACHI Pc=400mW f _T =50MHz	"				
1401,	2SD476 ©, ①	HITACHI Pc=40W f _T =7MHz	"				
2							
1501	2SC1449 ©	NEC Pc=5W f _T =65MHz	"				
1502	2SC681	HITACHI Pc=50W f _T =7MHz	"				
1701	2SC1921	HITACHI Pc=600mW f _T =130MHz	"				
~3							
1910	2SC1685	MATSUSHITA Pc=250mW f _T =150MHz	"				
IC1101	TA7607AP		IC				
1201	HA11401		"				
1301	TA7622AP		"				
1501	HA11244		"				
1601	HA11107		"				

TRC-2300A (RADIO/AMPLIFIER P.B.ASS'Y) PARTS LIST

Symbol No.	Parts No.	Rating	Parts Name	Symbol No.	Parts No.	Rating	Parts Name
R2222	QVG5A2A-014	10kΩ	VR (Tone)	C2845	QCF11HP-103	0.01μF 50V +100% -10%	C Cap.
2223	" -014	10kΩ	" (Volume)	2846	QFM41HK-333	0.033μF 50V K	M Cap.
2226	QRC121K-2R2	2.2Ω ½W K	Comp. R	2847	QCF11HP-103	0.01μF 50V +100% -10%	C Cap.
2501	QRG019J-391	390Ω 1W J	OM R	2851	QCF11HP-203	0.02μF " "	"
2838	QVZ323O-054	50kΩ 0.3W ±30%	VR (IC Bias)	2852, 53	QFM41HK-223	0.022μF 50V K	M Cap.
2908	QVG5A2W-024	20kΩ	" (Mixing)	2858	QEW41EA-335	3.3μF 25V +75% -10%	E Cap.
2920	QRC121K-335	3.3MΩ ½W K	Comp. R	2859	QCF11HP-103	0.01μF 50V +100% -10%	C Cap.
2921	QRC121K-121	120Ω " "	"	2860	QEW41CA-106	10μF 16V +50% -10%	E Cap.
2925	QVZ323O-054	50kΩ 0.3W ±30%	VR (Bias)	2863	QEW41EA-335	3.3μF 25V +75% -10%	"
C2221	QFM41HK-183	0.018μF 50V K	M Cap.	2864	QCY11HK-472	0.0047μF 50V K	C Cap.
2222	QFM41HK-683	0.068μF " "	"	2865	QCY11HK-331	330pF " "	"
2223	QEW41HA-474	0.47μF 50V +75% -10%	E Cap.	2867	QCF11HP-102	0.001μF 50V +100% -10%	"
2224	QFM41HK-392	0.0039μF 50V K	M Cap.	2868	QFM41HK-103	0.01μF 50V K	M Cap.
2225	QEW41AA-107	100μF 10V +50% -10%	E Cap.	2870, 71	QCF11HP-103	0.01μF 50V +100% -10%	C Cap.
2226	QEW41CA-476	47μF 16V +50% -10%	"	2872	QCF11HP-102	0.001μF " "	"
2227	QFM41HK-104	0.1μF 50V K	M Cap.	2873	QEW41EA-335	3.3μF 25V +75% -10%	E Cap.
2228	QEW41CA-108	1000μF 16V +50% -10%	E Cap.	2874	QEW41AA-476	47μF 10V +50% -10%	"
2229	QEW41CA-227	220μF " "	"	2875	QFM41HK-103	0.01μF 50V K	M Cap.
2230	QCY11HK-471	470pF 50V K	C Cap.	2877	QEW41CA-106	10μF 16V +50% -10%	E Cap.
2231	QFM41HK-682	0.0068μF " "	M Cap.	2879	QCY11HK-152	0.0015μF 50V K	C Cap.
2232	QFM41HK-223	0.022μF " "	"	2884	QAT2002-001		Trimmer Cap.
2233	QEW40JA-477	470μF 6.3V +50% -10%	E Cap.	2886	QFM41HK-473	0.047μF 50V K	M Cap.
2801	QCY41HK-222	0.0022μF	C Cap.	2887	QCY11HK-103	0.01μF " "	C Cap.
2802	QAP1224-504		V Cap.	2888	QFM41HK-103	0.01μF " "	M Cap.
2806, 9	QCF11HP-103	0.01μF 50V +100% -10%	C Cap.	2890	QFM41HK-103	0.01μF " "	M Cap.
2810	QCT05CH-100	10pF 50V J	"	2892	QCF11HP-222	2200pF " +100% -10%	C Cap.
2813	QCT05CH-180	18pF " "	"	2893	QCF11HP-102	1000pF " +100% -10%	C Cap.
2814	QCF11HP-203	0.02μF 50V +100% -10%	"	2901	QEW41CA-336	33μF 16V +50% -10%	E Cap.
2816	QCT05CH-4R0	4pF	"	2902	QEW41EA-335	3.3μF 25V +75% -10%	"
2817	QCF11HP-103	0.01μF 50V +100% -10%	"	2903	QEW41HA-105	1μF 50V " "	"
2818	QFM41HK-683	0.068μF 50V K	M Cap.	2907	QEW41EA-335	33μF 25V " "	"
2819	QCF11HP-103	0.01μF 50V +100% -10%	C Cap.	2908	QEW41CA-106	10μF 16V +50% -10%	"
2826	QFM41HK-223	0.022μF 50V K	M Cap.	2909	QEW41HA-474	0.47μF 50V +75% -10%	"
2827 ~28	QFM41HK-103	0.01μF " "	"	2910	QEW41CA-477	470μF 16V +50% -10%	"
2829 ~31	QFM41HK-473	0.047μF " "	"	2913	QEW41HA-105	1μF 50½ +75% -10%	"
2832	QFM41HK-103	0.01μF 50V K	M Cap.	2914	QFM41HK-472	0.0047μF " K	M Cap.
2835	QCF11HP-103	0.01μF 50V +100% -10%	C Cap.	2915	QFM41HK-272	0.0027μF " "	"
2836, 37	QEW41AA-107	100μF 10V +50% -10%	E Cap.	2916	QFM41HK-152	0.0015μF " "	"
2838	QCF11HP-103	0.01μF 50V +100% -10%	C Cap.	2917	QEW41AA-107	100μF 10V +50% -10%	E Cap.
2839	QFM41HK-103	0.01μF 50V K	M Cap.	2918	QCY11HK-331	330pF 50V K	C Cap.
2841	QFM41HK-223	0.022μF " K	M Cap.	2919	QFM41HJ-682	0.0068μF 50V K	M Cap.
2842	QEW41AA-227	220μF 10V +50% -10%	E Cap.	2921	QFM41HK-102	0.001μF 50V K	"
2843	QEW41CA-106	10μF 16V +50% -10%	"	2922	QFM41HK-272	0.0027μF " "	"
2844	QEW41EA-335	3.3μF 25V +75% -10%	"				

Symbol No.	Parts No.	Rating	Parts Name	Symbol No.	Parts No.	Rating	Parts Name
C2923	QEW41CA-106	10 μ F 16V +50% -10%	E Cap.	X2804	2SC460 (B)	HITACHI Pc=200mW f _T =230MHz	Transistor
2925	QEW41AA-336	33 μ F 10V " "	"	2805	2SA844 (C)	HITACHI Pc=300mW f _T =200MHz	"
2927	QEW41AA-107	100 μ F " " " "	"	2806	2SC460 (B)	HITACHI Pc=200mW f _T =230MHz	"
2928	QEW41AA-476	47 μ F " " " "	"	2901, 02	2SC458PG (C)	HITACHI Pc=200mW f _T =230MHz	"
2929	QCF11HP-102	1000pF 50V +100% -0%	C Cap.	2903	2SC2001 (K, L)	NEC Pc=600mW f _T =170MHz	"
2930	QCY11HK-151	150pF 50V K " "	"	2904, 05	2SC945L (O)	NEC Pc=250mW f _T =450MHz	"
2931	QEW41CA-106	10 μ F 16V +50% -10%	E Cap.	IC2001	LA1201		IC
2932	QCF11HP-103	0.01 μ F 50V +100% -10%	C Cap.	2002	TBA810 33A		"
2933	QFM41HK-153	0.015 μ F 50V K " "	M Cap.	2003	TA7137P (B, C)		"
2934	QFM41HK-472	0.0047 μ F " " " "	"	S2003	QSL8300-001		Lever Switch
2935	QEW41CA-106	10 μ F 16V +50% -10%	E Cap.	2004	AX49293		Power Switch
2936, 37	QEW41CA-106	10 μ F 16V +100% -10%	E Cap.	2005	QSS9201-005		Slide Switch
2938	QCF11HP-203	0.02 μ F +100% -10%	C Cap.	2006	QSS2316-001		"
2939	QCF11HP-103	0.01 μ F 50V " " " "	"	2007	A32048-00A		Jack Board
2940, 1	QEW41CA-106	10 μ F 16V +100% -10%	E Cap.	2011	QSP2210-061		Push Switch
2943	QFM41HK-123	0.012 μ F 50V K " "	M Cap.	T2810	A32047-00A		Bar ANT. Ass'y
6001	QEW41CA-227	220 μ F 16V +50% -10%	E Cap.	CF3	A04403-001		Ceramic Filter
L2201	A04359-100		Choke Coil	CF4	A04371-001		"
2202	A04359-100		Choke Coil	CR6	03126-15		CR Block
2801	A45638-00A		RF Coil	7	A03008-020		"
2802	03226-1L		Inductor	BPF-2	A45437-00A		Band Pass Filter
2803	A45663-001		OSC Coil	J2007	QMC9014-006		Din Socket
2901	03226-17		Inductor				
2902	A04725-470		Peaking Coil				
6001	T41572-001		Choke Coil				
T2801	VQT7F12-102		If Transf.				
2802	VQM1T03-201		OSC Coil				
2803	V03067-026		Ceramic F				
2805	VQT7F11-202		If Transf.				
2806	V03067-25		"				
2807	VQT7F15-502		"				
2808	VQT7F16-602		"				
2809	A45823-00A		OSC Coil				
2901	A45738-00A		Bias OSC Transf.				
D2501	RD6.2E-B		Zener Diode				
2801	SD113		Varicap Diode				
2802	1N60		Ge. Diode				
2803, 04	1S2076		Si. Diode				
2805, 06	1N60		Ge. Diode				
2087 ~9	1N34A		Ge. Diode				
2810	1S2076		Si. Diode				
2811	1N34A		Ge. Diode				
2901	1N34A		"				
2902	1S2076		Si. Diode				
2903	1N34A		Ge. Diode				
6001	V06-C		Si. Diode				
X2801, 2	2SC461 (C)	HITACHI Pc=200mW f _T =230MHz	Transistor				
2803	2SC460 (B)	HITACHI Pc=200mW f _T =230MHz	"				

CABINET PARTS LIST

View No.	Symbol No.	Parts No.	Parts Name	Remarks
1		A27465-D	Control Panel	
2		△ C39358-A	Antenna Terminal	
3	SW11	⚡ AX49431	Seesaw Switch	all-off Power Switch
4	SW10	△ AX49433	Voltage Selector	
5		C40755	Push Knob	for Degauss
6		A27476	Protector Glass	
7		A17252-F (A17252-E)	Front Panel	
8		A38314-6 (A38314-5)	Operation Plate	with in Front Panel
9		A27471-5	Ornament Panel	
10		A27497	Adhesive Sheet	for Ornament Panel
11		C40754-2	Band Knob	for TV Band
12		C40857-2	"	for Radio Band
13		C40753-B	Manual Knob	for Volume, Tone, Mixing
14		C40796-B	Select Knob	for Power Switch
15		A32048-00A	Jack Board	on the Radio/Amp P.B. Ass'y
16	S1	QSS2228-102	Slide Switch	Charge Switch
17	P1	△ AX49432	AC Socket	
18	J2	A75907-A	Ext. Battery Jack	
19		A38480-A	Power Panel	
20		A27466-4	Fitting	
21		C40756-A	Lighting Knob	
22		A27466-1	Fitting	
23		QXM2252-003	JVC Mark	
24		C40800-3	Door Plate	
25		A27468-C	Cassette Door	
26		C40763-6 (C40763-5)	Motor Plate	
27		A17253-EV0	Top Panel	
28		A38321-C	Handle	
29		C40772	Handle Bushing	
30		C40773	Handle Spring	
31		A38481-4 (A38481-3)	Rating Label	
32		A17248-DV0	Bottom Cover	
33		A38443-A	Rod Antenna	
34		A31892-00B	Rotor	
35		A45508-001	Rotor Cap	
36		A45574-001	Rotor Spring	
37		A45445-001	Rotor Holder	
38		A45507-001	Spring	
39		A45575-001	Rotor Sheet	
40	J3	QMC0233-101	Socket	Rechargeable Battery Socket
41		A75906	Caution Label	
42		A45375-001	Battery Plate	
43		C40870	Contact Spring	
44		A27463-DV0	Battery Cover	
45		A38364-B	Tuning Knob	for TV and Radio

() for CX-500EU

(VIEW OF CABINET)

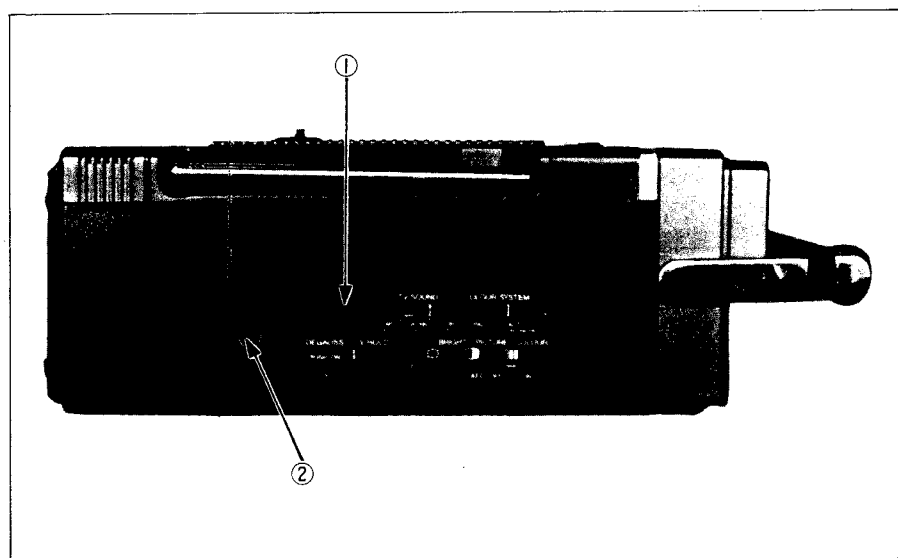

Fig. 52

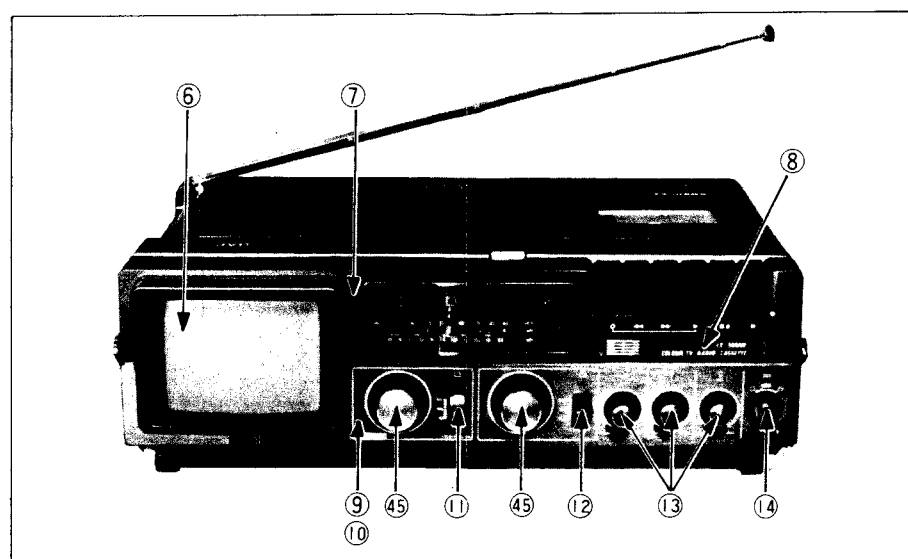

Fig. 53

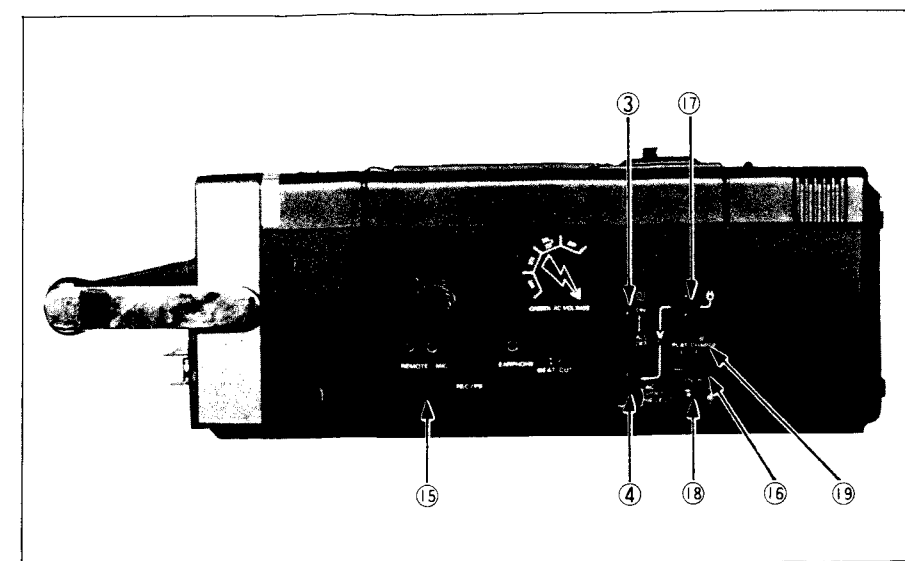

Fig. 54

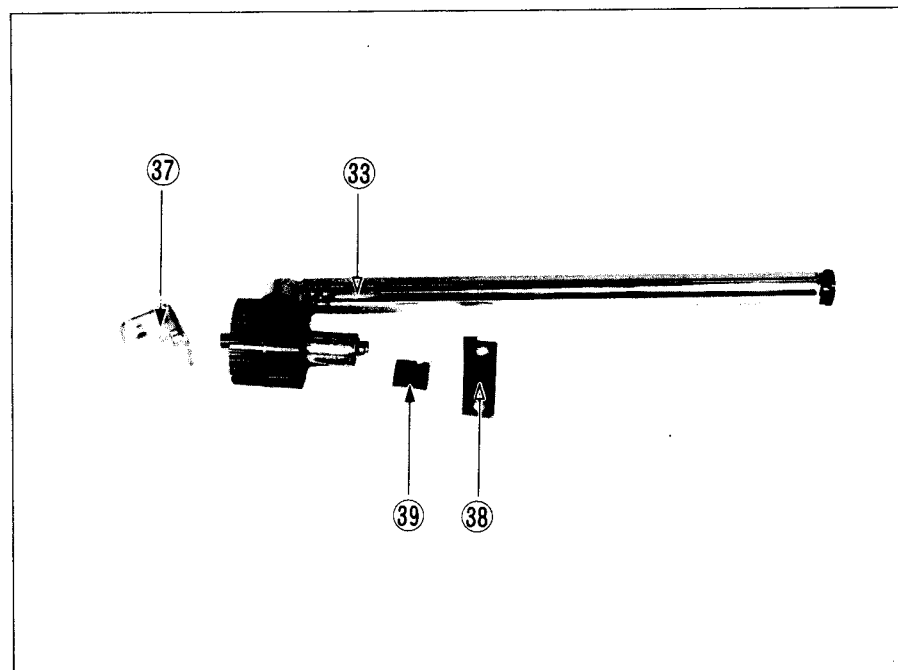

Fig. 55

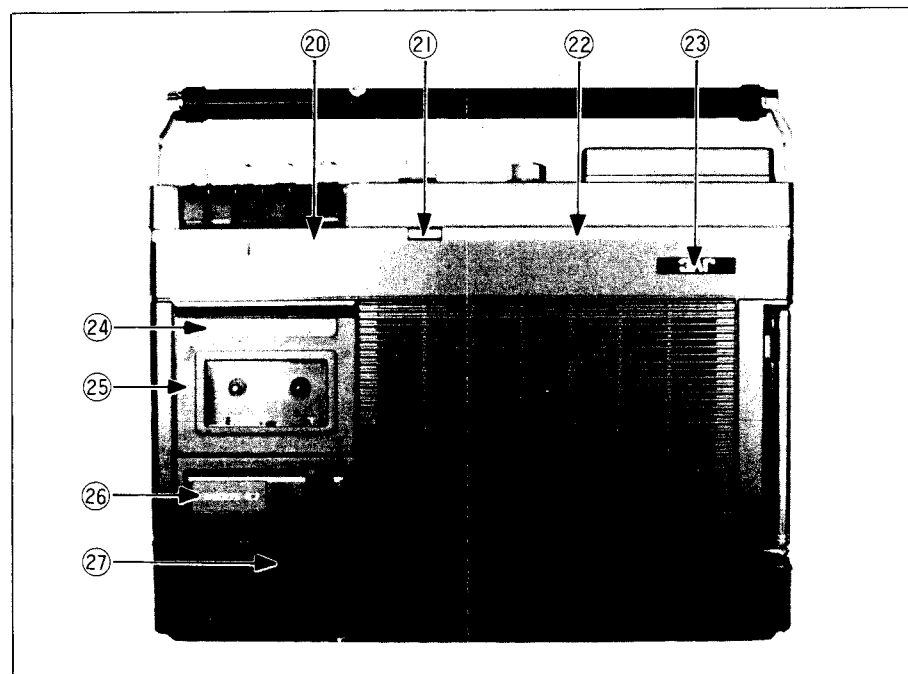

Fig. 56

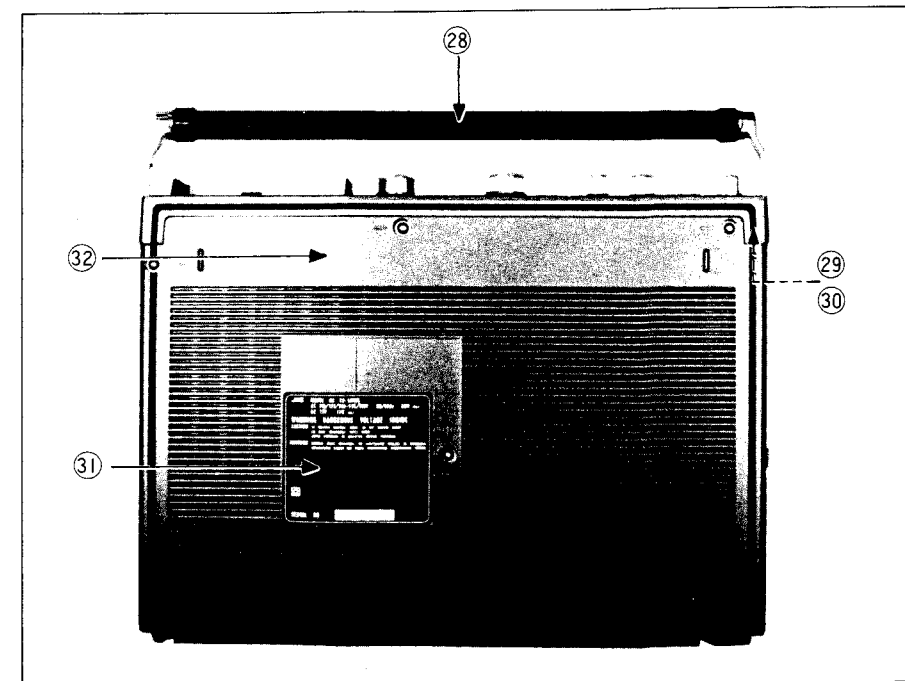

Fig. 57

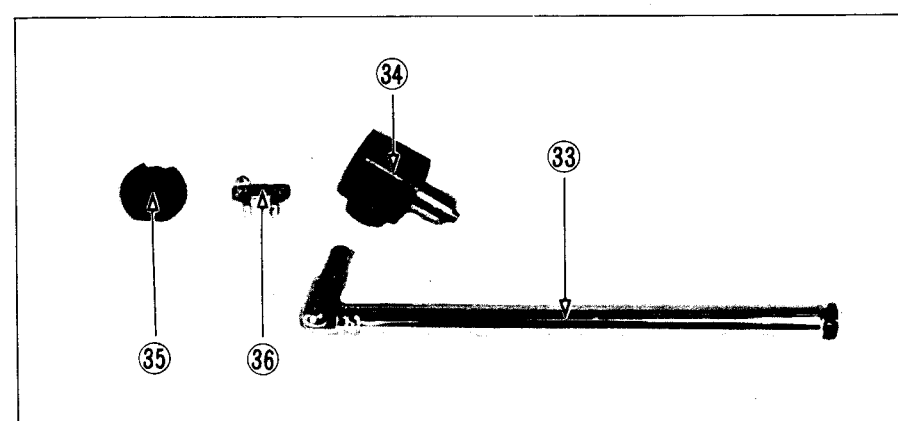

Fig. 58

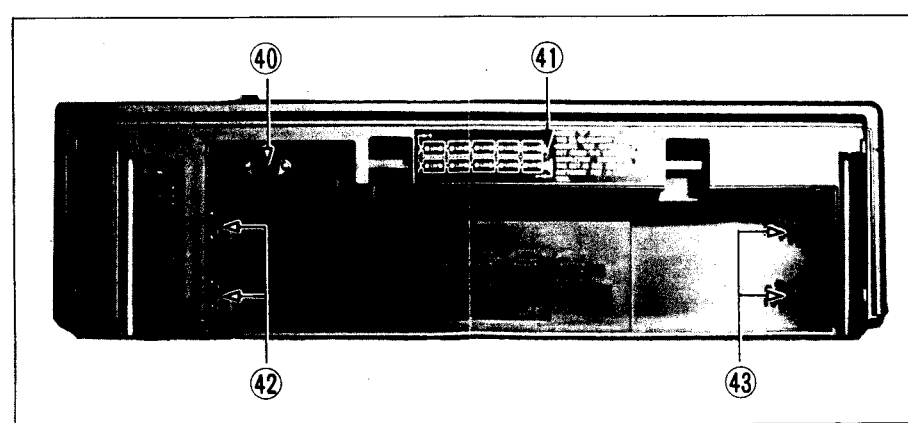

Fig. 59

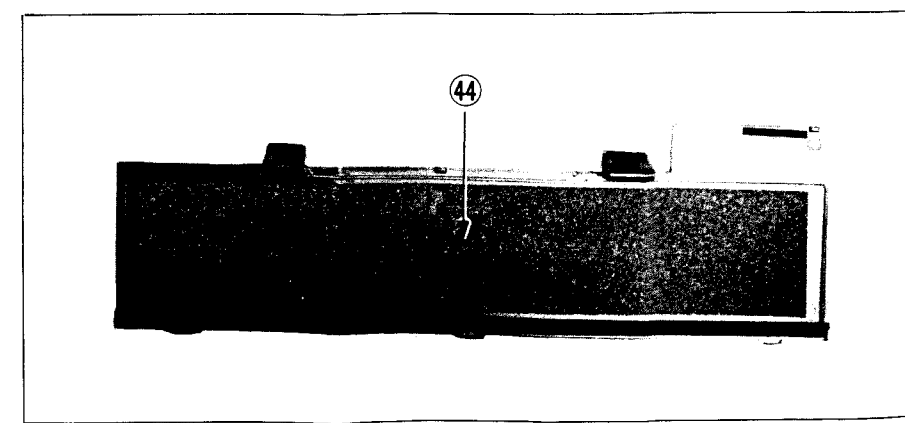

Fig. 60

EXPLODED VIEW OF CASSETTE MECHANISM

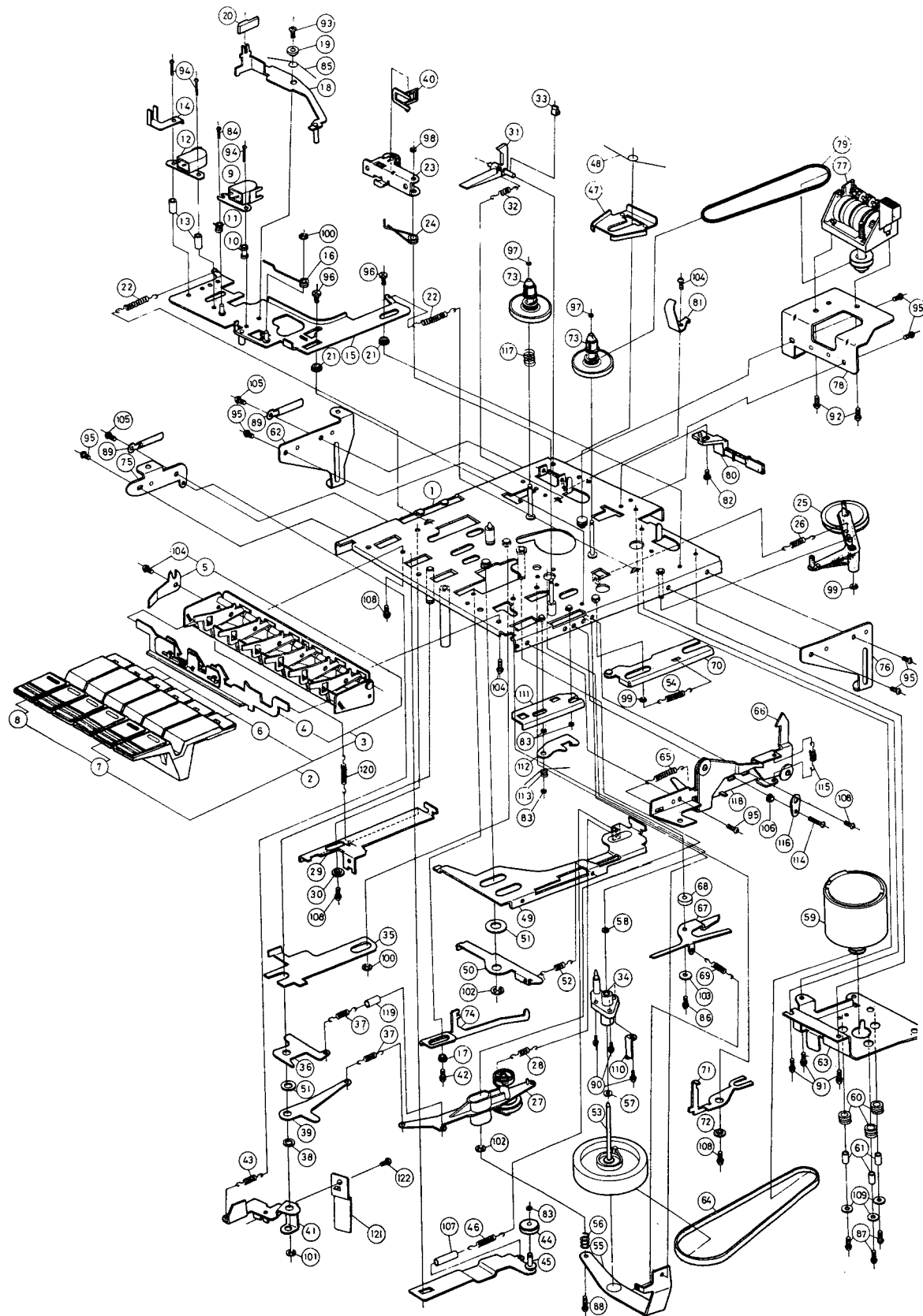

Fig. 61

CHASSIS PARTS LIST

View No.	Symbol No.	Parts No.	Parts Name	Remarks
1		A31856-001	Dial Drum	for TV
2		53498-3	Spring	"
3	R3	QVZ1163-001	V Resistor	"
4		A45773-001	Dial Cord	TV 63cm, Radio 80cm
5		C41090	Needle	
6		A38315-5	Dial Plate	for Radio
7		A38310	Dial Drum	"
8		53498-3	Spring	
9		A75760	Meter	
10	MC1	A04369-101	E.C. Mic	
11	PL1	QLP3104-314	Pilot Lamp	
12		A27461-A	Control Base	
13	L1	A29826-A	CRT DEG. Holder	with Deg. Coil
14		C40855-2	Earth Spring	
15	S2	QSP1210-021	Push Switch	for Dial Light
16	V1	△ 140BYB22(E)	Picture Tube	
17		C30195	Wedge	
18	DY1	△ A29906-V	Def. Yoke	
19		A46480	P/C Magnet	
20		△ C39158-A	CRT Socket	
21	SP1	EAS-12P105SD	Cone Speaker	12cm 6Ω
22	R1	QRF108K-150	UNF Resistor	15Ω 10W K
23	R2	QRF108K-2R2	"	2.2Ω 10W K
24	T1	△ C39270-YA	Power Transformer	
25		C41195	Door Spring	for Cassette Door
26	T1502	△ A29905-A	HV Transformer	with Focus VR
27		△ C30213-A	Focus V Resistor	
28		△ A46445	Focus Terminal Cover	
29	TU01	EM7641ES	E. Tuner	for VHF/UHF
30	PL2	QLP3104-107	Lamp	
31	F1	△ QMF51A2-1R0	Fuse	T1.0A
32	F2	△ QMF51A2-R50	Fuse	T500mA
33	R5	QRG026J-680		68Ω 2W J
34	D1	V06-C	Silicon Diode	
		TRC-1200A	Color TV P.B. Ass'y	
		TRC-2300A	Radio/Amp. P.B. Ass'y	
		TRC-4200A	Side Control P.B. Ass'y	
		TRC-5200A	PAL/SECAM P.B. Ass'y	
		TRC-7200A	TV Band SW P.B. Ass'y	
		TRC-9200A	Power Source P.B. Ass'y	

RECHARGEABLE BATTERY PACK PARTS LIST (CB-15E)

View No.	Symbol No.	Parts No.	Parts Name	Remarks
1		A38412-A	Fuse Box	
2		A38413	Fuse Box Cover	
3		A45531-001	Terminal	
4		△ QMF63R1-5R0	Fuse (5A)	
5		A75857	Caution Label	
		AP3855-2	Packing Case	
		AP3856	Cushion	
		CB-15E-IB-A	Instruction Book	

(VIEW OF CHASSIS)

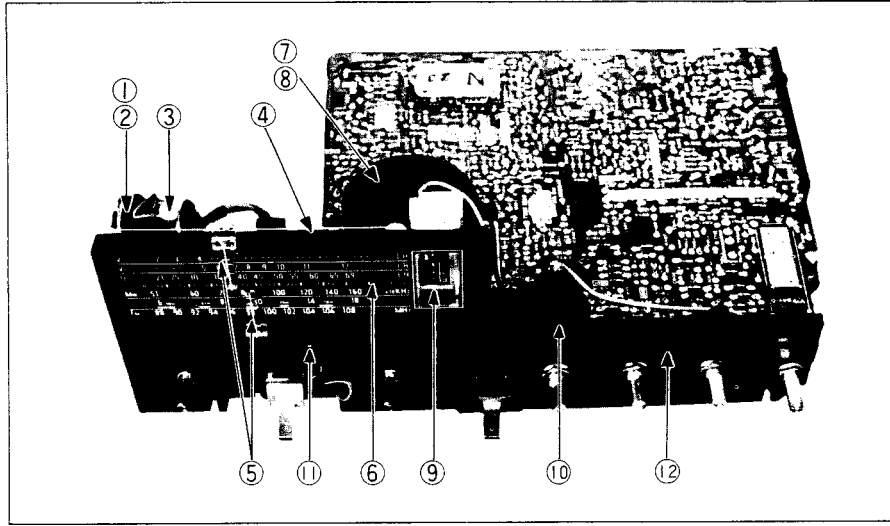

Fig. 62

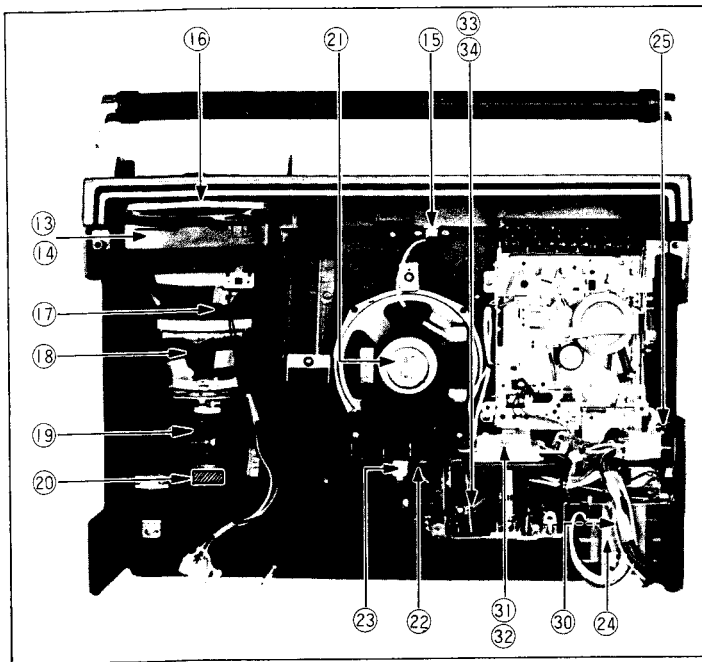

Fig. 63

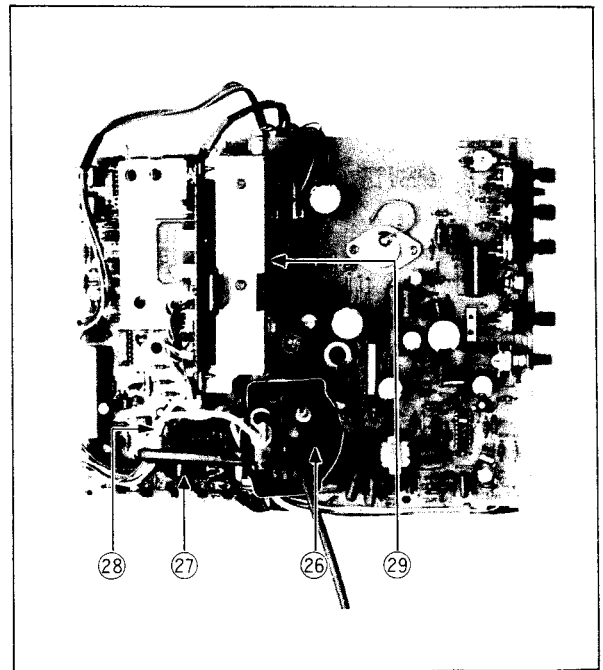

Fig. 64

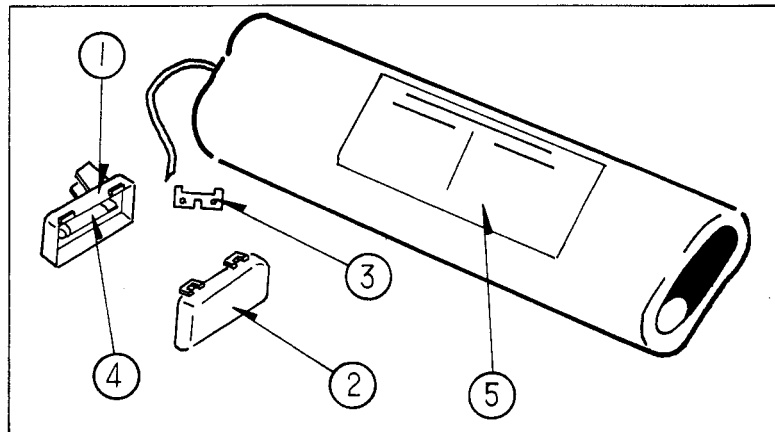

Fig. 65

CASSETTE MECHANISM PARTS LIST

View No.	Parts No.	Parts Name	Remarks	Qty
1	12990181ZT	Mecha Chassis Ass'y		1
2	12990292ZT	Push Button Switch Composite Ass'y		1
3	8290291ZT	Push Button Switch Ass'y		1
4	8290281ZT	Lock Plate Ass'y		1
5	170203T	Button Plate Spring		1
6	VXP2001-001	Key Button	for Play, FF, Rwd, Pause	4
7	VXP2001-003	Key Button	for Stop Eject	1
8	VXP2001-002	Key Button	for Rec.	1
9	T48301-001	R/P Head		1
10	4080402T	R/P Head Stud	for R/P Head	1
11	480408T	Spring	"	1
12	V03078-026	E. Head		1
13	8290410T	E. Head Stud	for E. Head	2
14	4080430T	Wire Clamp		1
15	5890481ZT	Head Panel Ass'y		1
16	4080811T	RQ. Spring		1
17	090302T	Collar	for Slide Lever	1
18	4080482ZT	Stop Detect Lever Ass'y		1
19	4080414T	Collar	for Stop Detect Lever	1
20	4531301T	Stop Detect Contact		1
21	4080411T	Collar	for Head Panel	2
22	4080413T	Spring	"	2
23	8290481ZT	Pinch Roller Ass'y		1
24	4080503T	Pinch Roller Spring		1
25	12380791ZT	Clutch Ass'y		1
26	2380406T	Spring	for Clutch Ass'y	1
27	6680891ZT	FF. Idler Ass'y		1
28	581316T	Spring	for FF. Idler Arm Ass'y	1
29	12790301T	Rec. Slide Lever		1
30	090301T	Collar	for Rec. Slide Lever	1
31	2680503T	Rec. Safety Lever		1
32	1320303T	Spring	for Rec. Safety Lever	1
33	2680515T	Stopper		1
34	3690701T	FL. Brock		1
35	4080806T	RQ. Function Plate		1
36	4080815T	Rew. Function Plate		1
37	4080810T	Spring	for FF/Rew.	1
38	1510305T	Special Washer		1
39	4080804T	FF. Function Plate		1
40	8290411T	Tape Stopper		1
41	8200303T	Rec. Lever		1
42	LPSP2608Z	Ass'y Screw		1
43	180502T	Spring	for Rec. Lever	1
44	2110902T	Rew. Idler		1
45	9701081ZT	Rew. Idler Arm Ass'y		1
46	020905BT	Spring	for Rwd. Idler Arm	1
47	4080901T	Brake Arm		1
48	4080902T	Spring	for Brake Arm	1
49	4080903T	Brake Function Plate		1
50	4080807T	RQ. Lever		1
51	110505T	Special Washer		2
52	4080811T	Spring		1
53	10451101ZT	Flywheel Ass'y		1
54	4081510T	Spring	for Slide Lever Ass'y	1
55	4081195ZT	Flywheel Bracket Ass'y		1
56	060405T	Spring		1
57	4081120T	Special Washer		1
58	031503T	Special Washer		1
59	12991292ZT	Motor Ass'y		1
60	T45687-001	Rubber Cushion		3

View No.	Parts No.	Parts Name	Remarks	Qty
61	4081211T	Collar		3
62	12991602T	Amp Bracket (L)		1
63	8201201T	Motor Bracket		1
64	9731201T	Main Belt	(ϕ 81 x3xt0.6)	1
65	581204T	Spring	for Ejec Lever	1
66	6671303T	Lock Lever		1
67	4081405T	Aut. Stop Lever		1
68	4081402T	Collar		1
69	020708T	Spring	for Aut. Stop Lever	1
70	4081581ZT	Slide Lever Ass'y		1
71	4081503T	Pinch Roller Arm Lever		1
72	2381304T	Collar		1
73	5720695ZT	Reel Disk Ass'y		2
74	5420408T	Slide Lever	for Play	1
75	8291920T	Side Bracket		1
76	12991601T	Amp Bracket (R)		1
77	VKC5115-001T	Tape Counter		1
78	12991701T	Counter Bracket		1
79	8001602T	Counter Belt		1
80	6301401T	Leaf Switch	(MSW-0038)	1
81	6010101T	Pack Spring		1
82	SDSP2605Z	Screw	for Leaf Switch	1
83	REE1500	E Ring		4
84	SPSX2006Z	P.M Screw	for R/P Head	1
85	4080515T	Spring	for Stop Detect Lever	1
86	LPSP2607Z	Ass'y Screw	for Aut. Stop Lever	1
87	SPSP2607Z	Screw	for Motor	3
88	SPSP2610Z	Screw		1
89	4660901T	Wire Clamp		2
90	LPSP2005Z	Ass'y Screw	for FL. Brock	1
91	LPSP2604Z	Ass'y Screw	for Motor Bracket	3
92	LPSP3006Z	Ass'y Screw	for Tape Counter	2
93	SSSP2005Z	Screw		1
94	SPSP2011Z	Screw	for R/P Head, E. Head	3
95	SPSD2604Z	TH. TAP Screw		7
96	SDSP2604Z	Screw	for Head Panel	2
97	REE1200	E Ring	for Reel Disk Ass'y	2
98	REE1900	E Ring	for Pinch Roller Arm Ass'y	1
99	REE2000	E Ring		2
100	REE2500	E Ring		2
101	REE3200	E Ring		1
102	REE4000	E Ring		2
103	7061501T	Washer		1
104	SPSP2606Z	Screw		3
105	SPSD2606Z	TH. TAP Screw		2
106	8291905T	Collar		1
107		Tube		1
108	LPSP2605Z	Ass'y Screw		4
109	031501T	Washer		3
110	4460701T	Earth Plate		1
111	5421881ZT	Pause Slide Lever Ass'y		1
112	8291401T	Pause Lever		1
113	5421803T	Pause Lever Spring		1
114	SPSD2610Z	TH. TAP Screw		1
115	150102T	Spring	for Ejec Lever	1
116	540402T	Eject Stopper Plate		1
117	040508T	Spring Back Tension	for Take-up	1
118	8291991ZT	Eject Lever Ass'y		1
119		Vinyl Tube	for Rwd. Arm	1
120	9410502T	Spring	for Rec. Slide Lever	1

TRC-4200A (SIDE CONTROL P.B. ASS'Y) PARTS LIST

Symbol No.	Parts No.	Rating	Parts Name	Symbol No.	Parts No.	Rating	Parts Name
C4001	QCF11EZ-103	0.01 μ F 25V $\begin{smallmatrix} +80 \\ -20 \end{smallmatrix}$ %	C Cap.				
SW4001 4002	AX49325 AX49436	(AUTO-PAL) (5.5-6-6.5MHz SOUND)	Slide Switch "				

TRC-5200A (PAL/SECAM P.B.ASS'Y) PARTS LIST

Symbol No.	Parts No.	Rating	Parts Name	Symbol No.	Parts No.	Rating	Parts Name
R5002 5006	AX49449 QVZ3230-023	10 Ω $\frac{1}{4}$ W K 2k Ω B	Fusible R VR (DL AMP)	C5030	QCF11EZ-102	1000pF 25V $\begin{smallmatrix} +80 \\ -20 \end{smallmatrix}$ %	C Cap.
C5003	QCF11EZ-103	0.01 μ F 25V $\begin{smallmatrix} +80 \\ -20 \end{smallmatrix}$ %	C Cap.	5033	QCF11EZ-103	0.01 μ F 25V $\begin{smallmatrix} +80 \\ -20 \end{smallmatrix}$ %	"
5004	QEE51CM-335	3.3 μ F 16V M	Tan. Cap.	5035	QEW41EA-475	4.7 μ F 25V $\begin{smallmatrix} +100 \\ -10 \end{smallmatrix}$ %	E Cap.
5005	QEE51CM-225	2.2 μ F 16V M	"	5036	QFM41HK-223	0.022 μ F 50V K	M Cap.
5006	QCF11EZ-103	0.01 μ F 25V $\begin{smallmatrix} +80 \\ -20 \end{smallmatrix}$ %	C Cap.	5037	QCT05CH-390	39pF 50V $\begin{smallmatrix} +50 \\ -10 \end{smallmatrix}$ %	C Cap.
5007	QEW41CA-336	33 μ F 16V M	Tan. Cap.	5040	QEN41EM-335	3.3 μ F 25V M	E Cap.
5010	QAT3001-010	1pF	Trimmer Cap.	L5001	A74600-5R6	5.6 μ H	Peaking Coil
5012	QFM41HK-123	0.012 μ F 50V K	M Cap.	5002	A04725-5.6	5.6 μ H	"
5013	QEN41HM-105	1 μ F 50V M	BP E Cap.	T5001	A75325		BP Transf.
5014	QFM41HK-123	0.012 μ F 50V K	M Cap.	5002	A75097		DL P Transf.
5016, 7	QCF11EZ-103	0.01 μ F 25V $\begin{smallmatrix} +80 \\ -20 \end{smallmatrix}$ %	C Cap.	5003	A75140		BELL Transf.
5018, 9	QEW41EA-475	4.7 μ F 25V $\begin{smallmatrix} +100 \\ -10 \end{smallmatrix}$ %	E Cap.	5004	A76146		Ident. Transf.
5020 ~22	QCF11EZ-103	0.01 μ F 25V $\begin{smallmatrix} +80 \\ -20 \end{smallmatrix}$ %	C Cap.	5005	A75142		Discrip. Transf.
5024	QCT05CH-180	18pF 50V $\begin{smallmatrix} +50 \\ -10 \end{smallmatrix}$ %	"	5006	A75142		"
5025	QCF11EZ-102	1000pF 25V $\begin{smallmatrix} +80 \\ -20 \end{smallmatrix}$ %	"	D5001, 2	1S2473H-K		Si. Diode
5029	QCT05CH-180	18pF 50V $\begin{smallmatrix} +50 \\ -10 \end{smallmatrix}$ %	"	IC5001 5002	AN5620N AN5630N		IC "
				DL5001 Y5001	A75103-B A76090		1H Delay Line Crystal

TRC-7200A(TV BAND SWITCH P.B.ASS'Y) PARTS LIST

Symbol No.	Parts No.	Rating	Parts Name	Symbol No.	Parts No.	Rating	Parts Name
R7003 7004 7005	QVP5A0B-014 QVP5A0B-054 QVP5A0B-014	10k Ω 50k Ω 10k Ω	VR (VL Tuning) " (VH Tuning) " (U Tuning)	C7002	QCF11EZ-102	0.001 μ F 25V $\begin{smallmatrix} +80 \\ -20 \end{smallmatrix}$ %	C Cap.
				IC7001	μ PC574J		IC
				S7001	QSL4310-011		Lever Switch

TRC-9200A (POWER SOURCE P.B.ASS'Y) PART LIST

Symbol No.	Parts No.	Rating	Parts Name	Symbol No.	Parts No.	Rating	Parts Name
R9000	QRC121K-471	470 Ω $\frac{1}{4}$ W K	Comp. R	D9007	V06-C		Si. Diode
9001	QRG016J-331	330 Ω 1W J	OM R	9008, 9	1S2473H		"
9003	QRV142F-2151	2.15k Ω $\frac{1}{4}$ W \pm 1%	CMF R	X9001	2S8566 (C), (D)	HITACHI Pc=40W f _T =15MHz	Transistor
9004	QVZ3230-052	500 Ω	VR (B ₁ Adj)				
9005	QRV142F-2201	2.2k Ω $\frac{1}{4}$ W \pm 1%	CMF R	9002	2SC1213A (C), (D)	HITACHI Pc=400mW f _T =50MHz	"
C9001	QEW41VH-109	10000 μ F	E Cap.	9003	2SD476 (C), (D)	HITACHI Pc=40W f _T =7MHz	"
9002	QEW41EA-477	470 μ F 25V $\begin{smallmatrix} +50 \\ -10 \end{smallmatrix}$ %	"	9004	2SC1213A (C), (D)	HITACHI Pc=400mW f _T =50MHz	"
9003, 05	QEW41CA-227	220 μ F 16V "	"	F9002	QMF51A2-3R15	T3.15A	Fuse
9006 ~8	QCF12HP-103	0.01 μ F 500V $\begin{smallmatrix} +100 \\ -10 \end{smallmatrix}$ %	C Cap.	L9001	A04096-100		Peaking Coil
9009	QEW41AA-477	470 μ F 10V $\begin{smallmatrix} +50 \\ -10 \end{smallmatrix}$ %	E Cap.				
D9001 ~4	ERD03-02J		Si. Diode				
9005	RD5.6EB1		Zener Diode				
9006	RD12EB		"				

10. BLOCK DIAGRAM

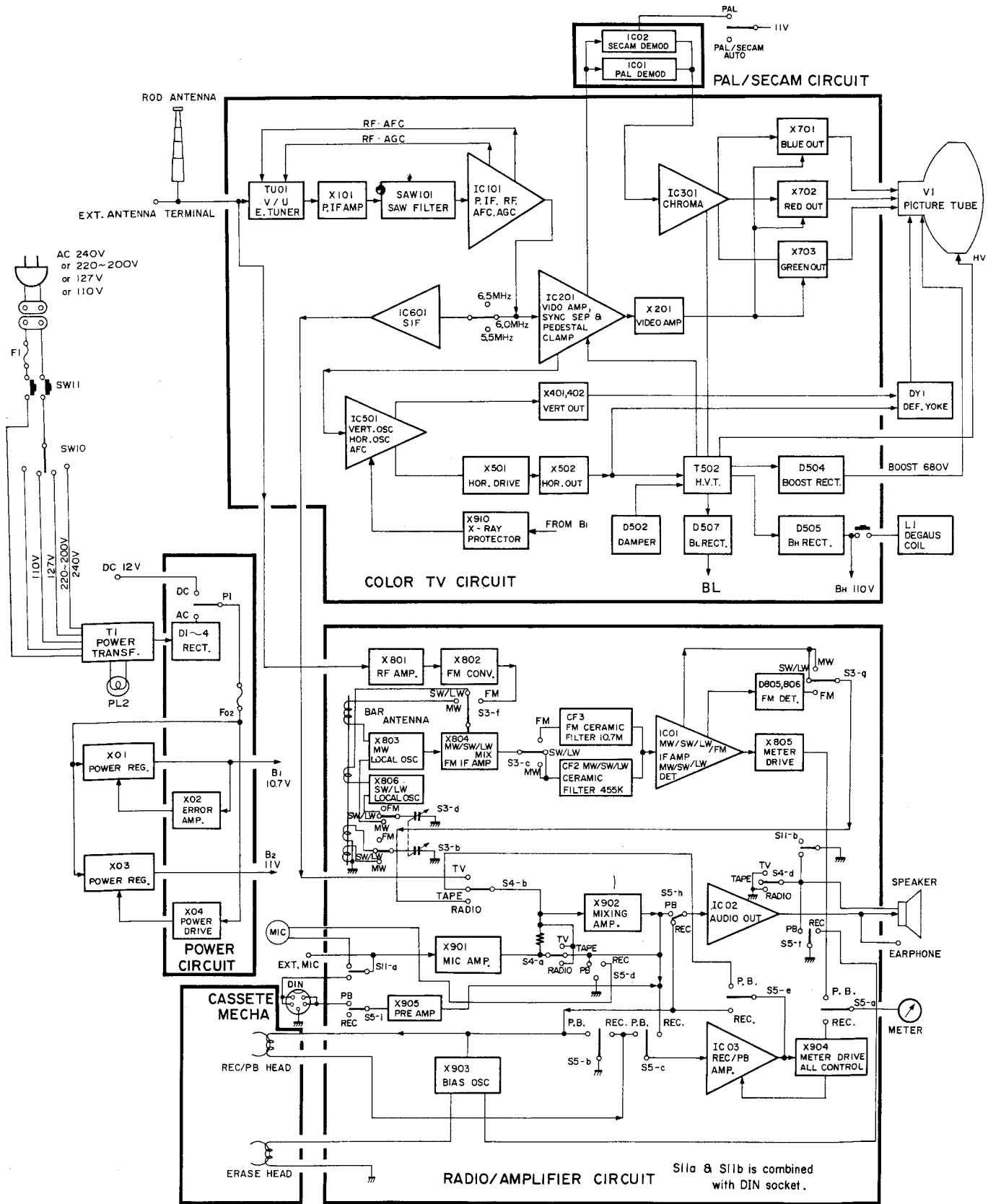

11. VHF/UHF E TUNER SCHEMATIC

EM7641ES

SYMBOL		
Symbol	Symbol No.	Semiconductor
	DT1 ~ DT8	ISV97
	DT15 ~ DT18	ISV70/MA324/IS2208
	DF1	ISV89/MA340
	DF2	ISV89/MA340
	DS1 ~ DS8	MA56
	DS9	IS2076/MAIGI
	Q1	3SK81
	Q2 ~ Q4	2SC2636
	Q5	3SK60
	Q6	2SC1070/2SC2464
	Q7	2SC2468

TRANSISTOR PIN CONNECTION

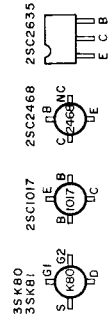

SYMBOL NAME

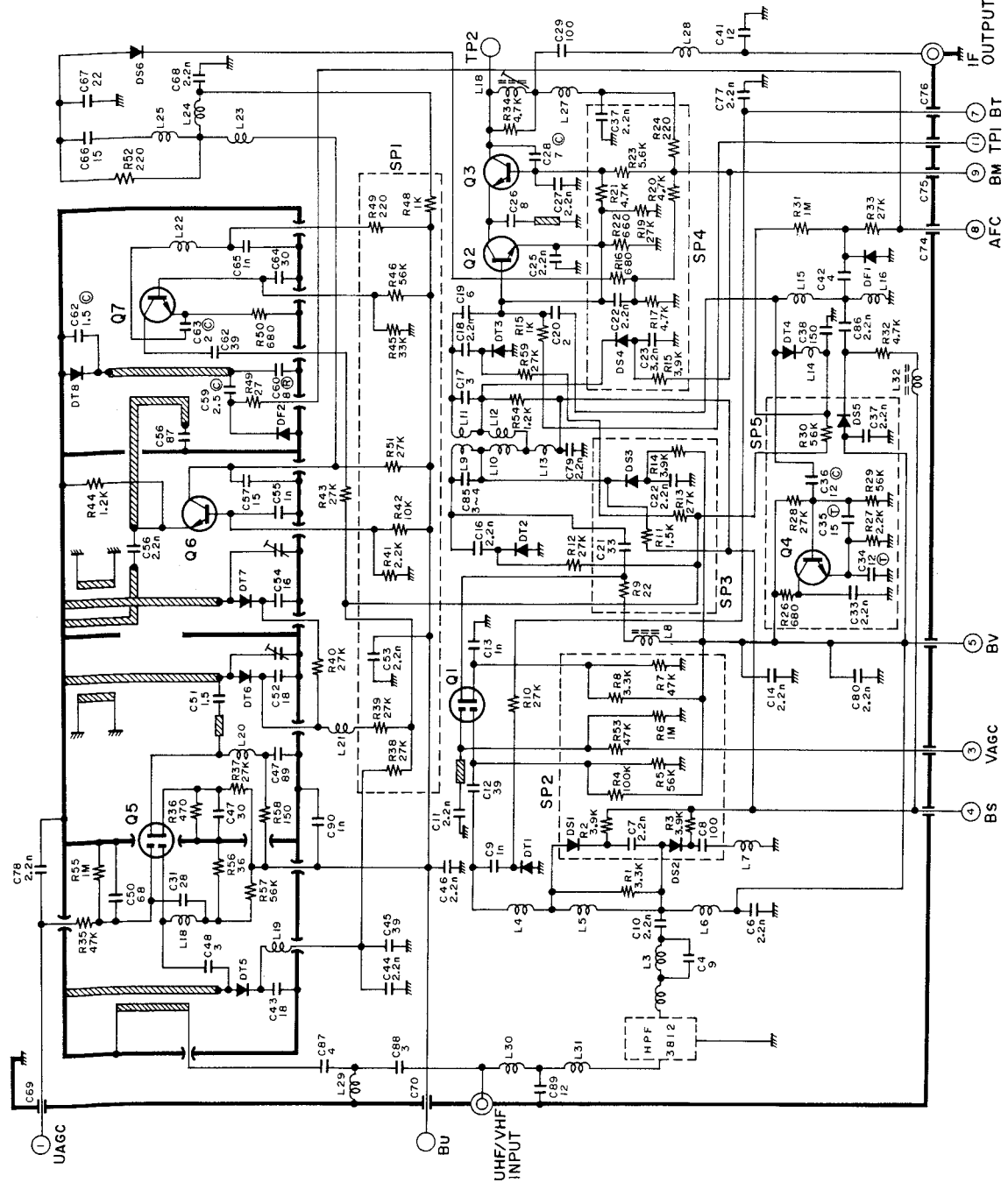
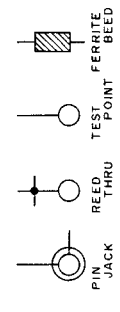

MODEL CX-500GB CX-500EU SCHEMATIC DIAGRAM

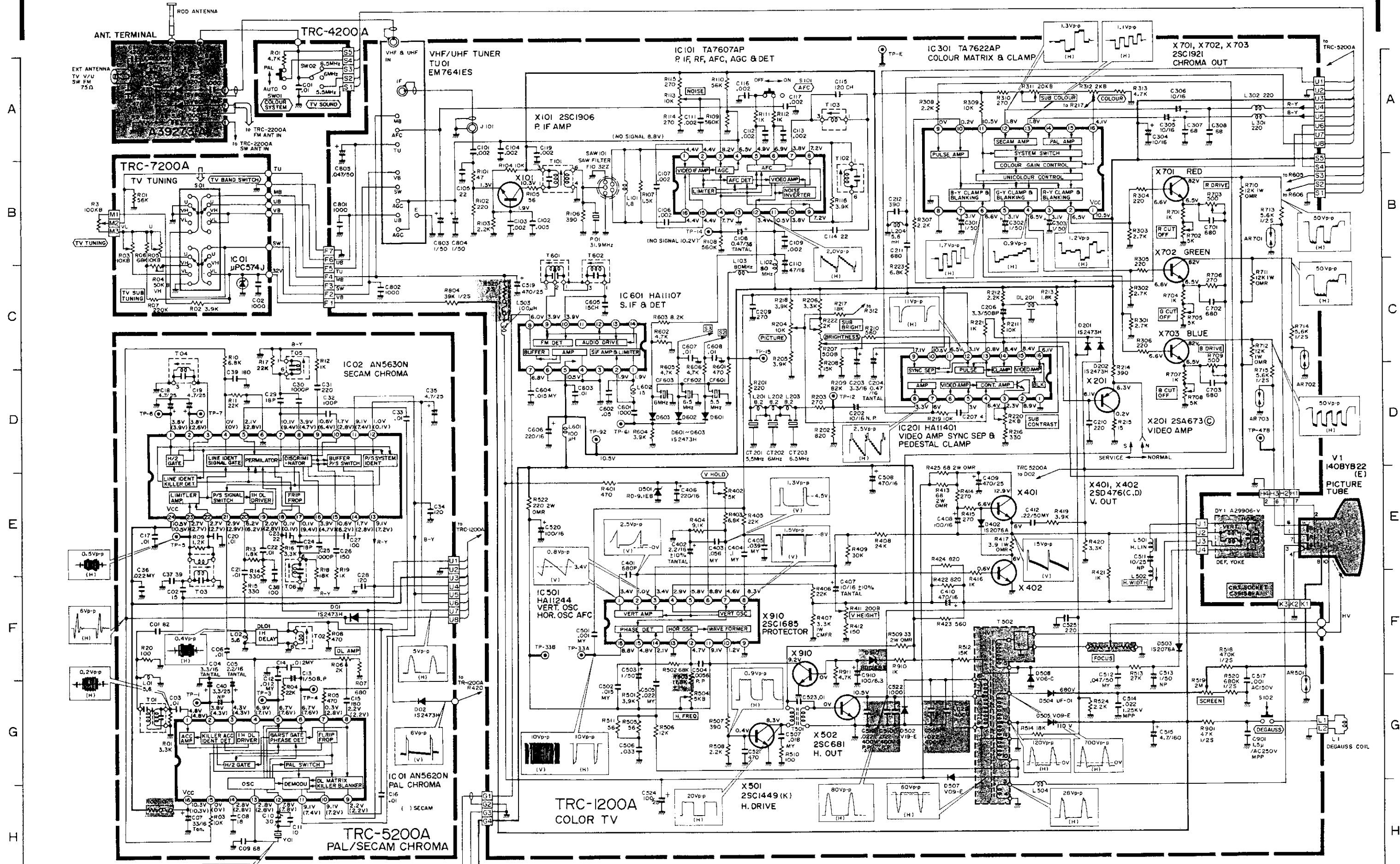

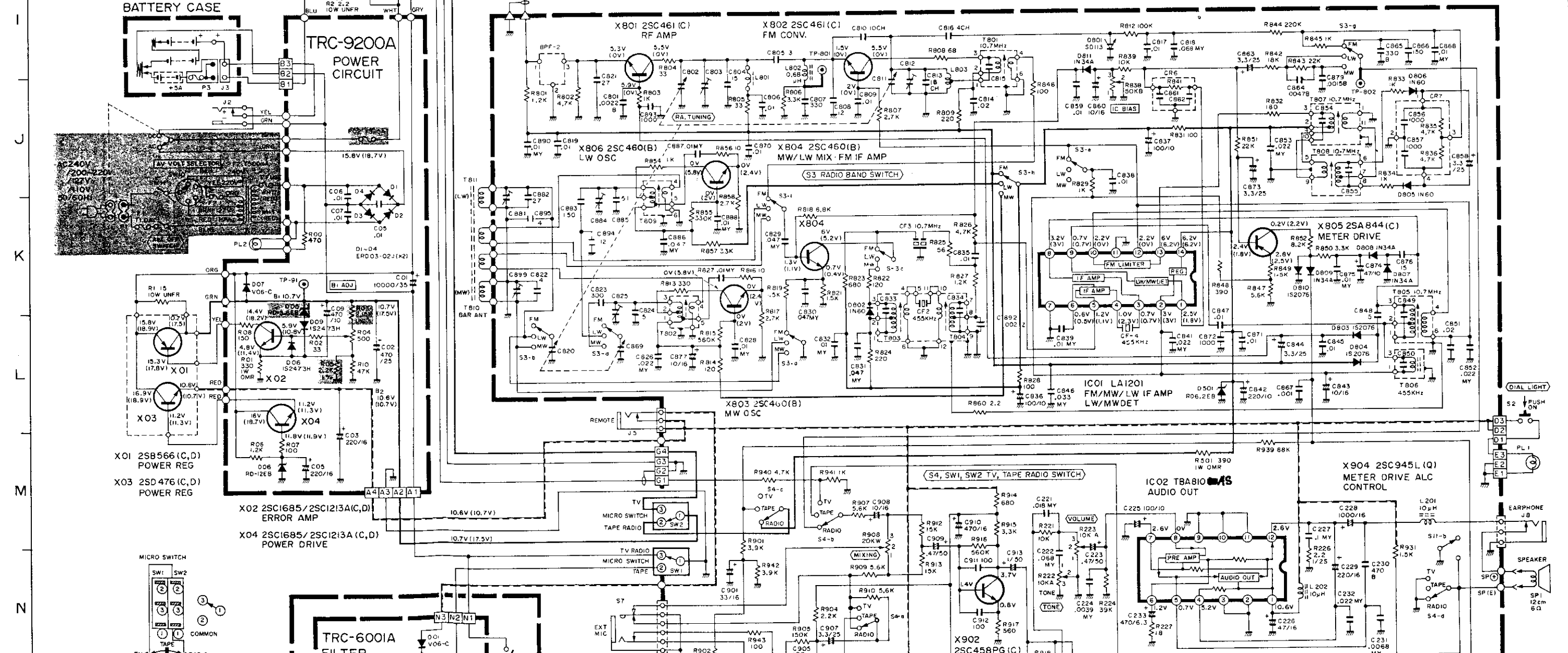
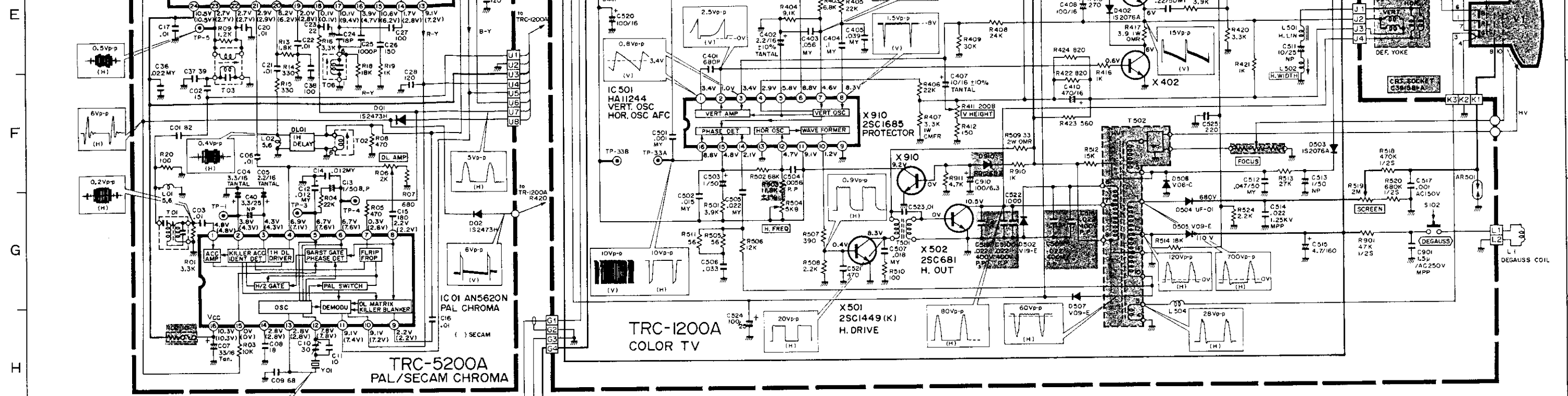

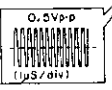

BATTERY CASE

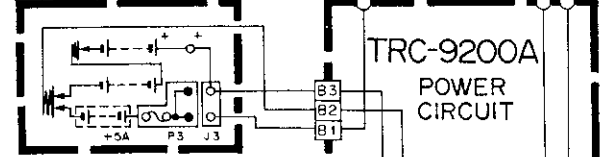

TRC-9200A POWER CIRCUIT

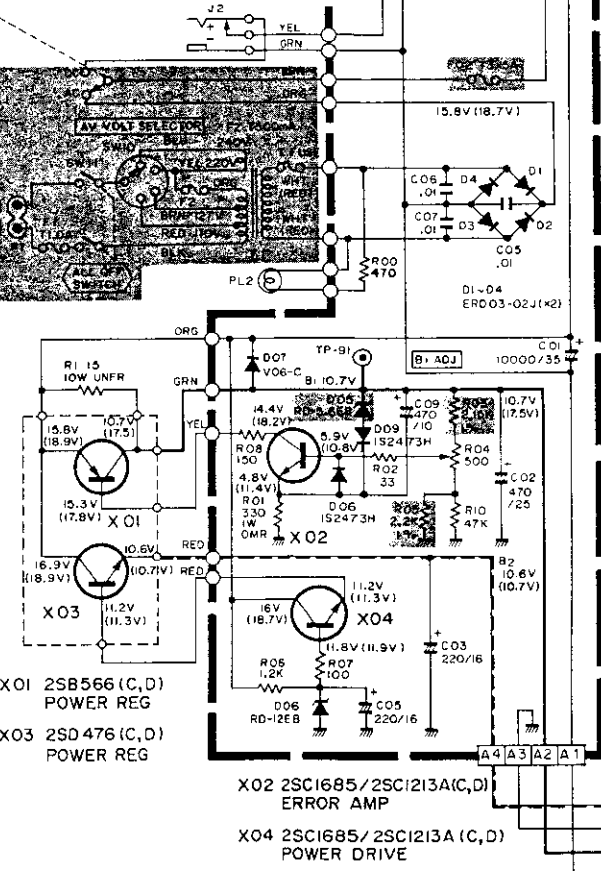

- X01 2SB566 (C,D) POWER REG
- X03 2SD476 (C,D) POWER REG
- X02 2SC1685/2SC1213A(C,D) ERROR AMP
- X04 2SC1685/2SC1213A (C,D) POWER DRIVE

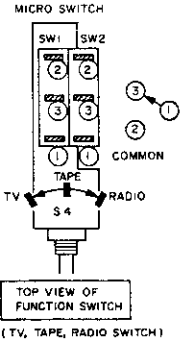

TRC-600IA FILTER

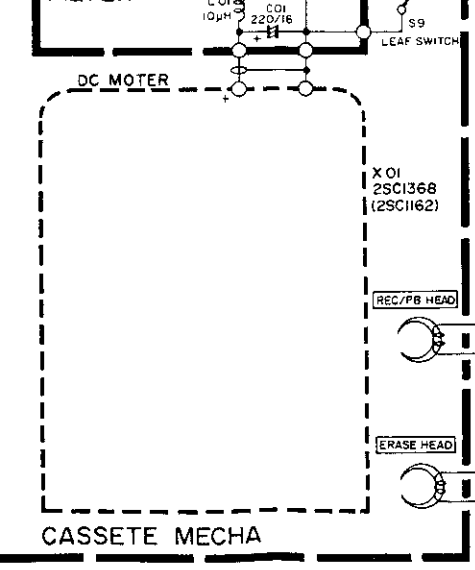

CASSETTE MECHA

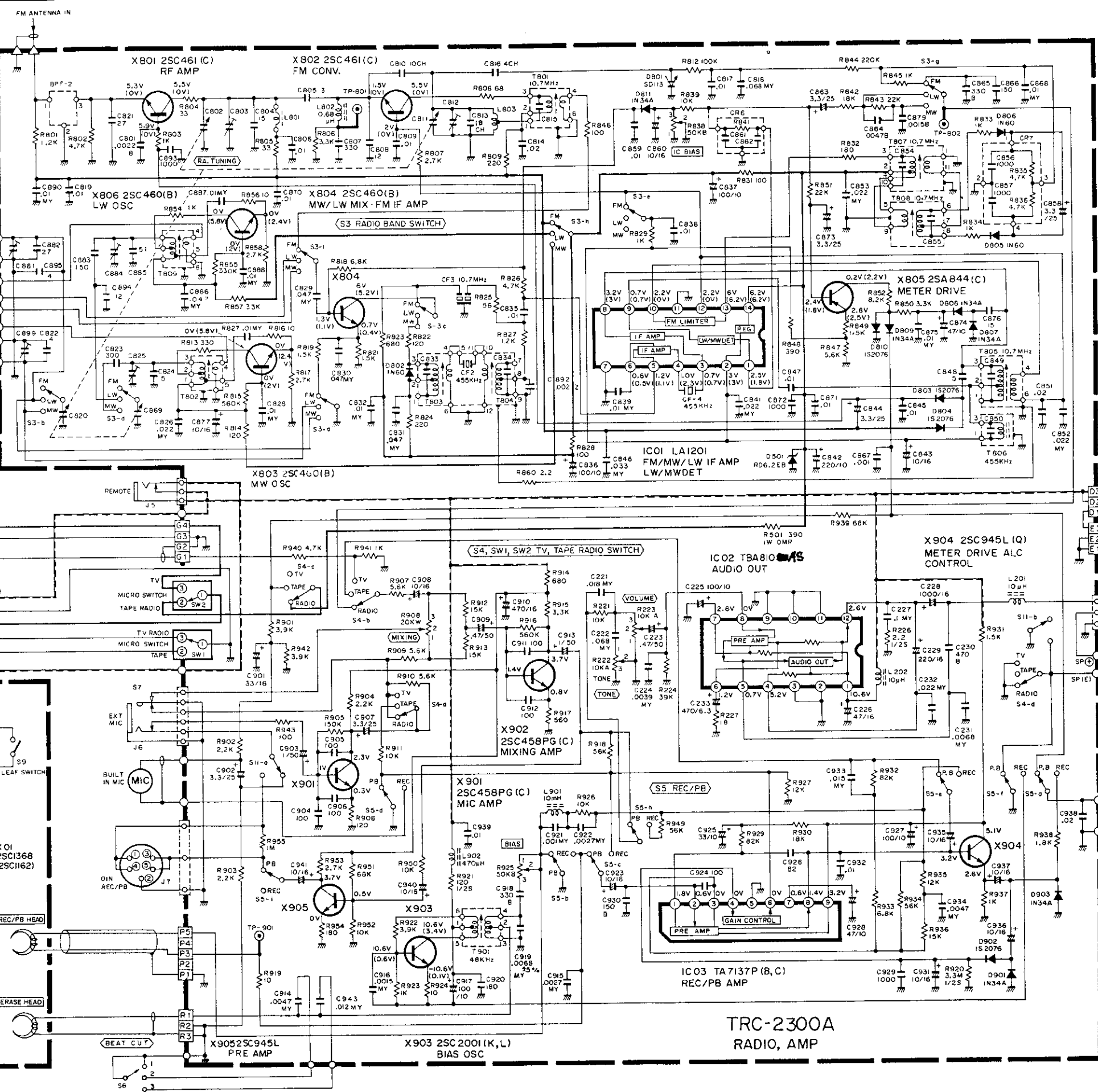

TRC-2300A RADIO, AMP



VICTOR COMPANY OF JAPAN, Ltd.
CX500GB, EU-HSA 540806EA

NOTE:

- The measuring is made as in connection with an AC source.
 - The voltage and oscillation from the TV circuit section are measured with the multimeter/oscilloscope, provided that the reception of color bar signals is sufficiently sensitive (0.825V Vp-p from the top of sync. signal to white peak, percentage modulation 85%). The voltage during black/white signal reception is shown in brackets ().
 - During the reception of FM broadcast, the voltage in the radio circuit is measured with sufficient sensitivity. The voltage during the reception of MW/LW broadcasts is shown in brackets ().
 - The voltage of the Amp-circuit is measured during playback mode of the tape recorder. The voltage during recording mode is shown in brackets ().
 - The voltage of the power supply circuit is measured during reception mode of the TV. The voltage under which only the tape recorder operates, is shown in brackets ().
 - The measurements were made with the each VR under the condition just after the shipment. The figures of the signal circuits may be more or less different after adjustment, so use the figures simply for reference.
- Multimeter used
DC 20kΩ/V
Give figures are all DC voltages. Sweep speed of oscilloscope:
H → 20μS/div.
V → 5mS/div.
Other → sweep speed specified
- Since the circuit diagram is a standard one, the circuit and circuit constants may be subject to change for improvement without any notice.

SCHEMATIC NOTES

UNLESS OTHERWISE SPECIFIED
Resistance: [Ω] (K → KΩ, M → MΩ), 1/4 [W] carbon resistor
Capacitance: 1 or higher → [pF], less than 1 → [μF] working voltage → 50 [V] ceramic capacitor
Inductance: [μH]
ELECTROLYTIC CAP.: capacitance value [μF]/working voltage [V], NP → non-polar (or bipolar) electrolytic cap.
Refer to the parts list in the SERVICE MANUAL about the tailed indications of parts.
⊙ symbols indicate test point-connections.
⚡ indicates chassis ground. Hz indicates cycles per second.

FOR SAFETY AND CONTINUED GOOD PERFORMANCE

- Replacing Fuse and shaded parts, be sure to use parts specified for safety purposes.
- For maximum reliability and performance, all other replacement parts should be identical to those specified.

CHECKPOINT OF B1 VOLTAGE

- Checking is possible at the position shown in MAIN ADJUSTMENTS LOCATION.
- Check or adjust B1 voltage under the item "Adjustment of B1 voltage".

ADJUSTMENT OF B1 VOLTAGE (10.7V)

Adjusting B1 voltage, use an accurate voltmeter. Should B1 control be set too high, it may cause possible damage of components.
Using a simple volt meter, it must be calibrated.

MAIN ADJUSTMENT LOCATION

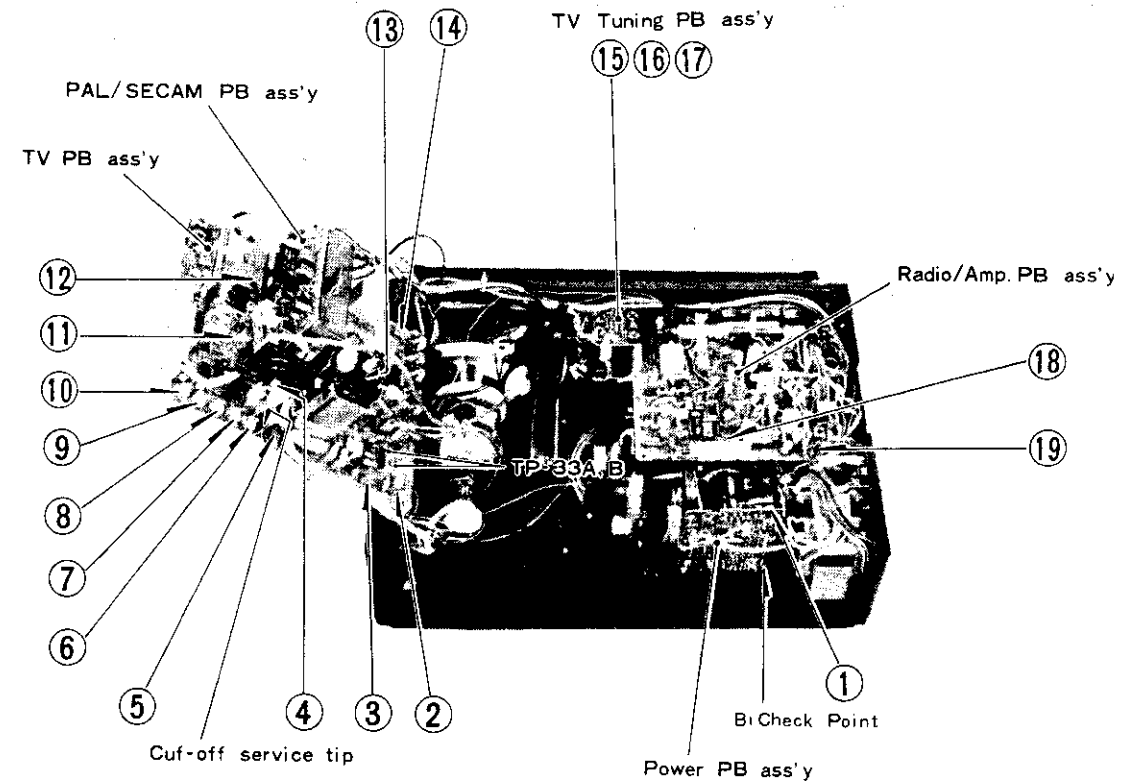

- | | | | |
|------------------|--------------|-----------------|-----------------|
| 1 B1 ADJ. | 2 H. FREQ. | 3 V. HEIGHT | 4 FOCUS |
| 5 SCREEN | 6 G. CUT-OFF | 7 R. CUT-OFF | 8 B. CUT-OFF |
| 9 R. DRIVE | 10 B. DRIVE | 11 SUB CONT. | 12 NOISE |
| 13 H. WIDTH | 14 SUB COLOR | 15 VH TV TUNING | 16 VL TV TUNING |
| 17 UHF TV TUNING | 18 IC BIAS | 19 REC BIAS | |

PARTS NO. LIST

(Shaded parts in the Schematic diagram)

Symbol No.	Parts No.	Parts Name
R1503	QRV142F-1182	CMF Resistor
R1525	AX49449-33	Fusible Resistor
C1509	AX49316-223	PP Capacitor
C1510	"	"
C1516	"	"
C1518	"	"
C1522	QCY12HK-102	C. Capacitor
D1910	RD12EB3	Zener Diode
T1502	A29905-A	F.B.T. (with Focus VR)
	C30213-A	Focus VR
R5002	AX49449-10	Fusible Resistor
R9003	QRV142F-2151	CMF Resistor
R9005	QRV142F-2201	"
D9005	RD5.6EB1	Zener Diode
F9002	QMF51A2-3R15	Fuse (T3.15A)
T1	C39270-YA	Power Transformer
P1	AX49432	AC Socket
F1	QMF51A2-1R0	Fuse (T1.0A)
F2	QMF51A2-R50	Fuse (T500mA)
SW10	AX49432	All-off Power Switch
SW11	AX49433	Voltage Selector
V1	140BYB22(E)	Picture Tube
DY1	A29906-V	Def. Yoke
	C39158-A	CRT Socket
	A39358-A	Ant. Terminal
	AX49383-R	Power Cord (for EU)
	AX49384-R	" (for GB)

MAIN PARTS LOCATION FOR TAPE-RECORDER

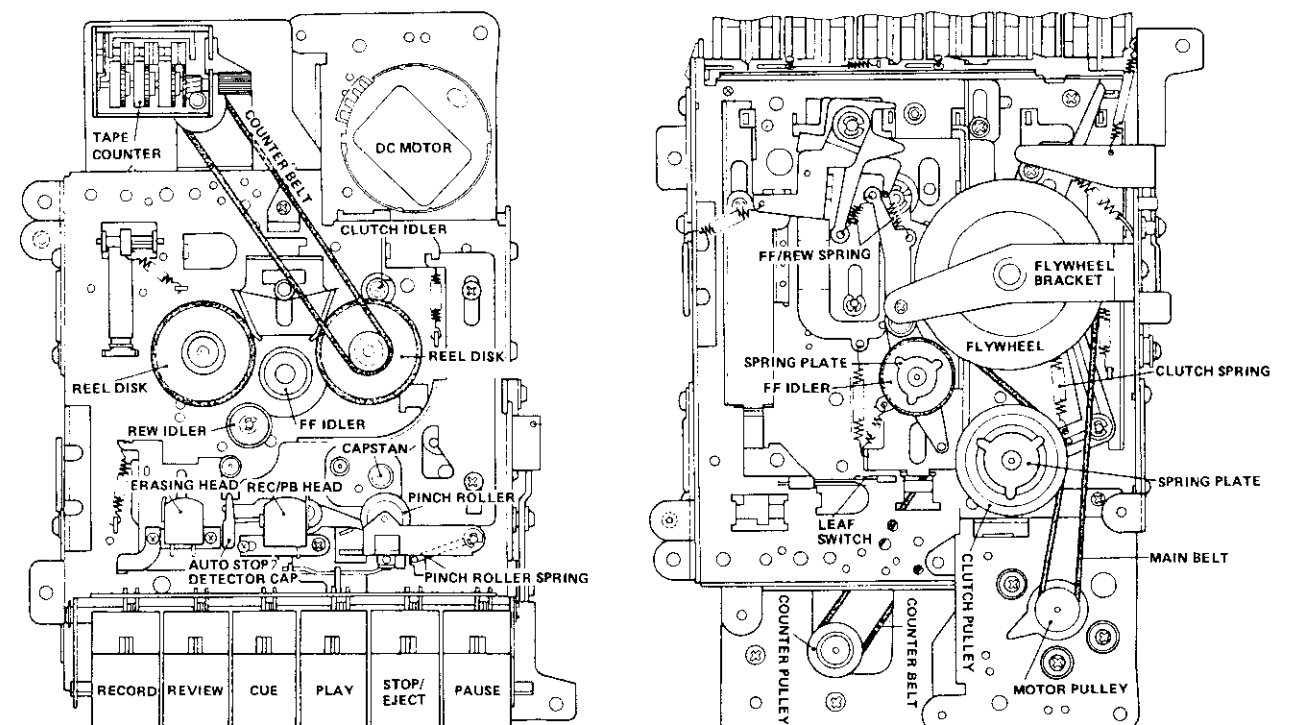

MAIN P. C. BOARD PATTERNS

BASINGS OF TRANSISTORS AND ICs

MAIN P. C. BOARD PATTERNS

FRONT ←

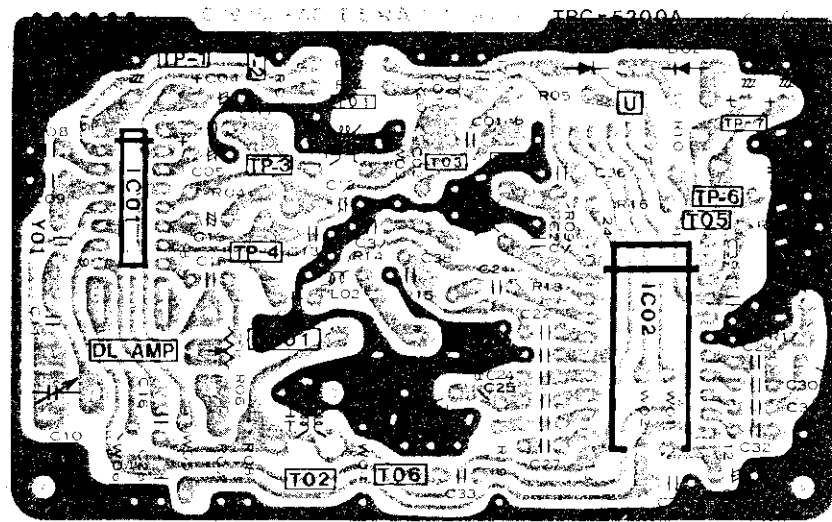

PAL/SECAM CIRCUIT

↑ FRONT

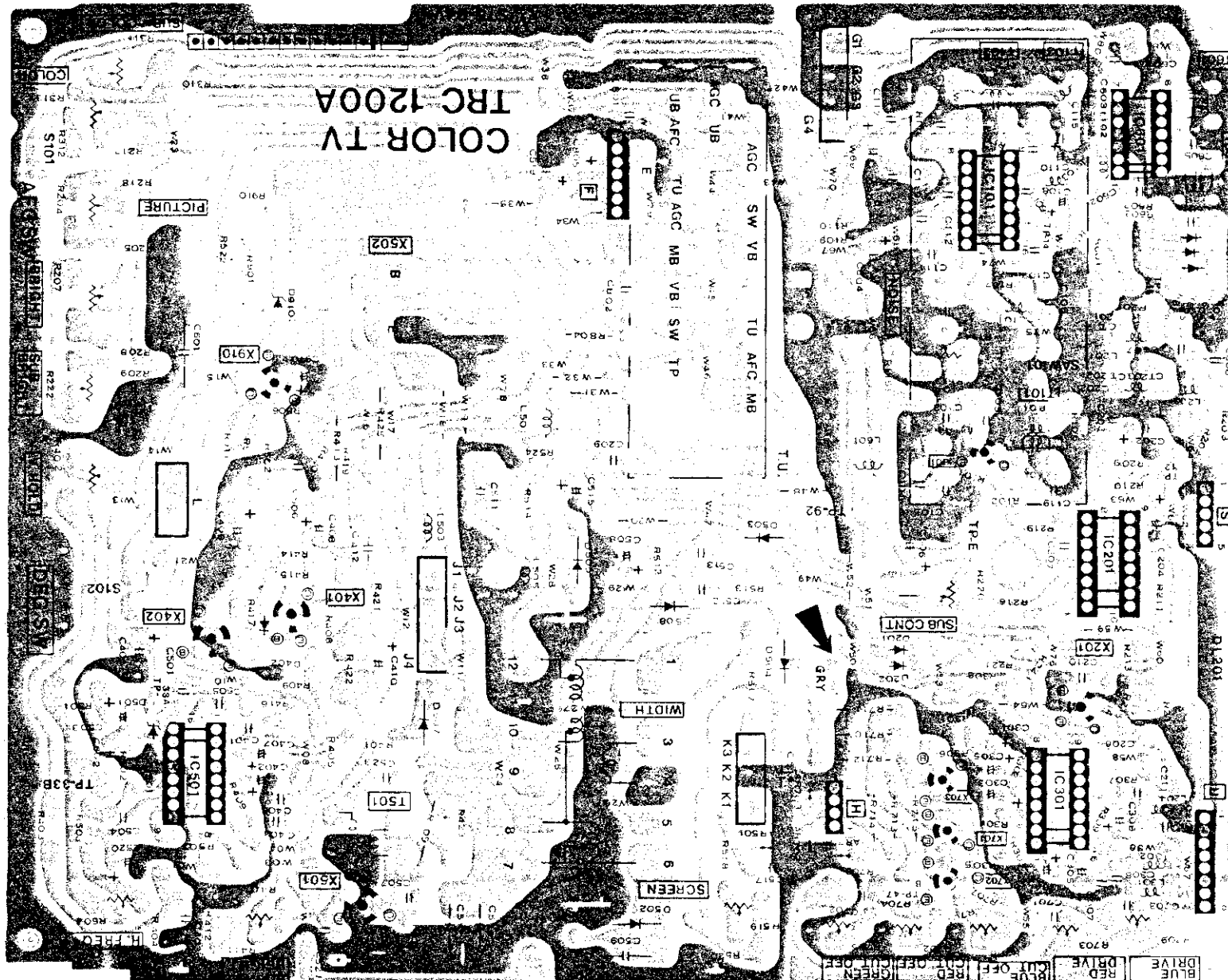

TELEVISION CIRCUIT

BASINGS OF TRANSISTORS AND ICs

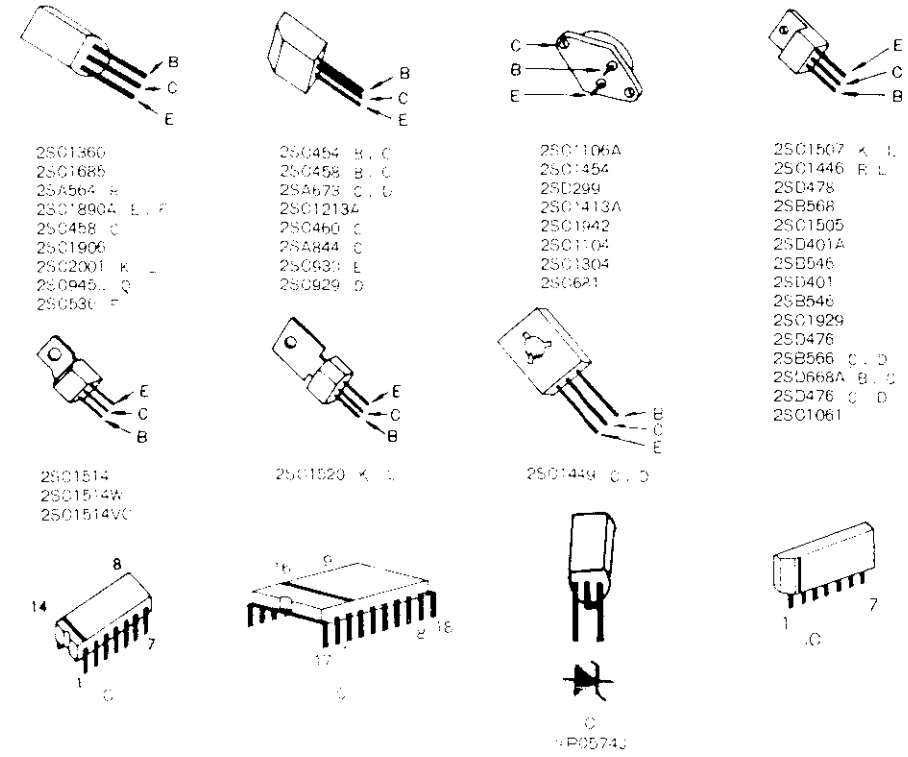

↑ FRONT

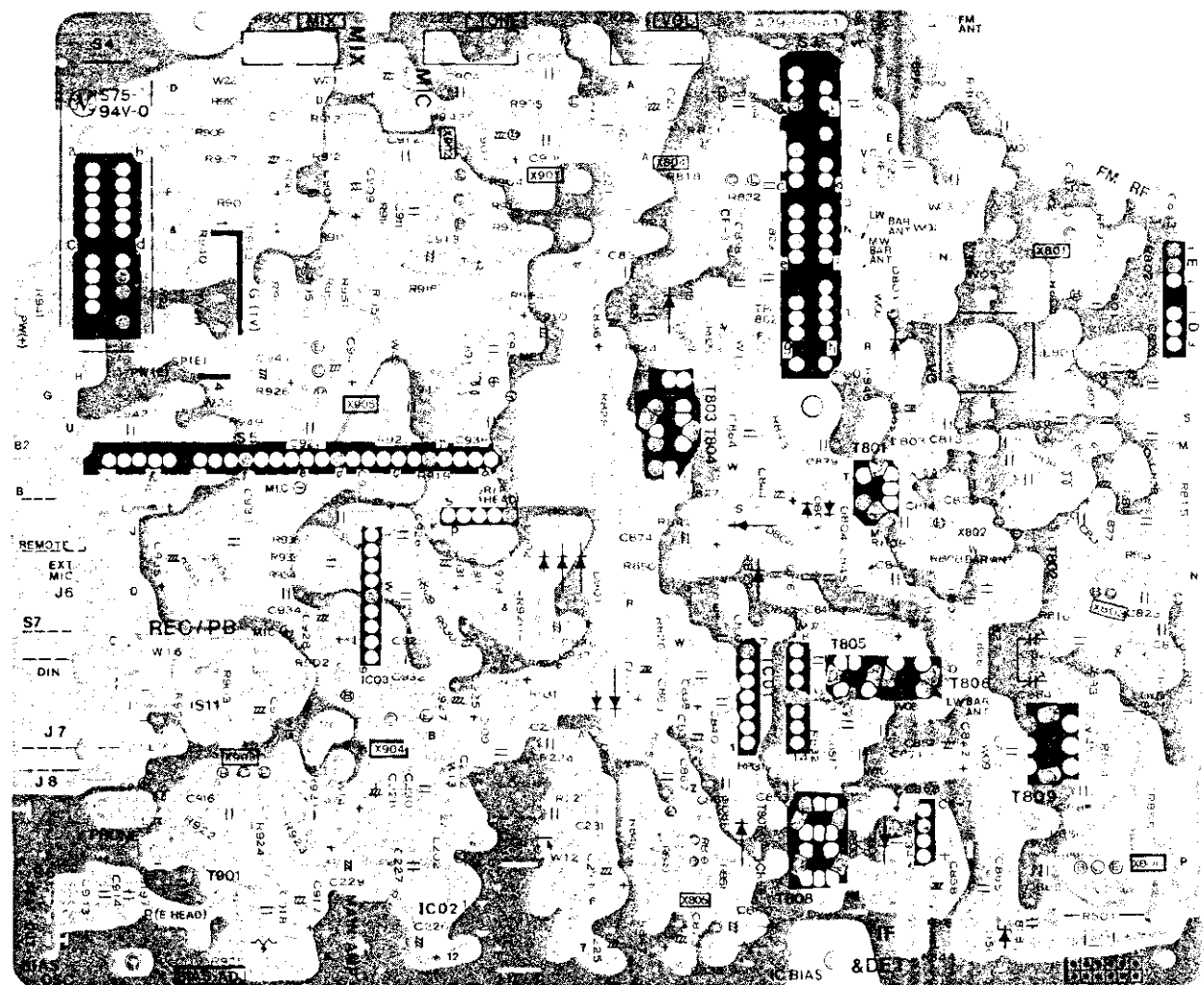

RADIO AMPLIFIER CIRCUIT

MAIN P. C. BOARD PATTERNS

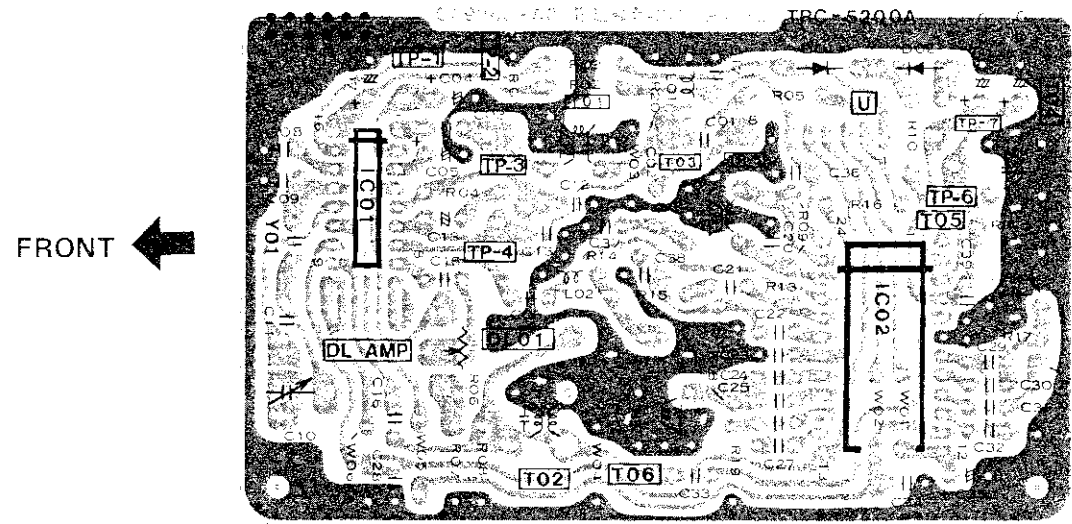

PAL/SECAM CIRCUIT

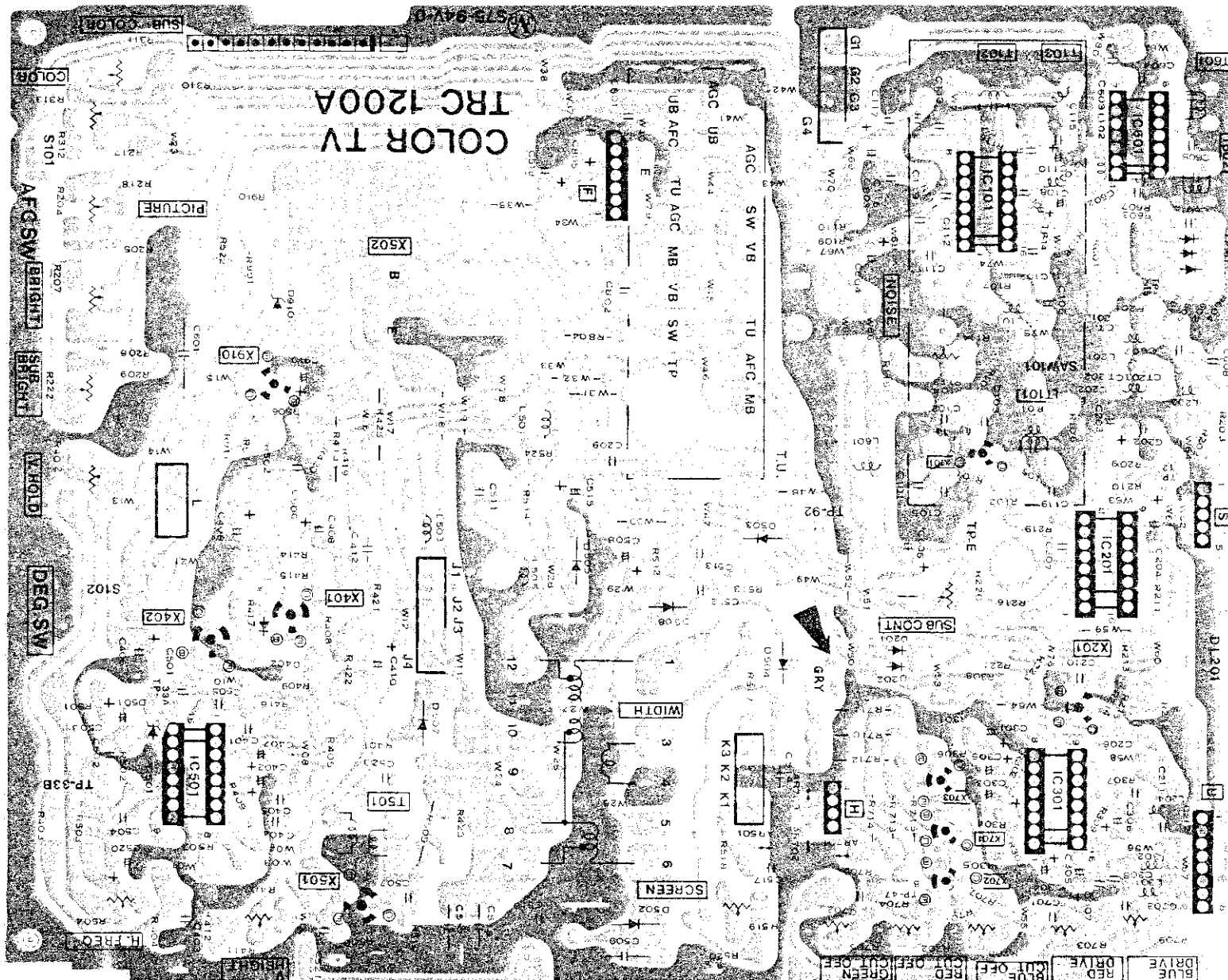

TELEVISION CIRCUIT

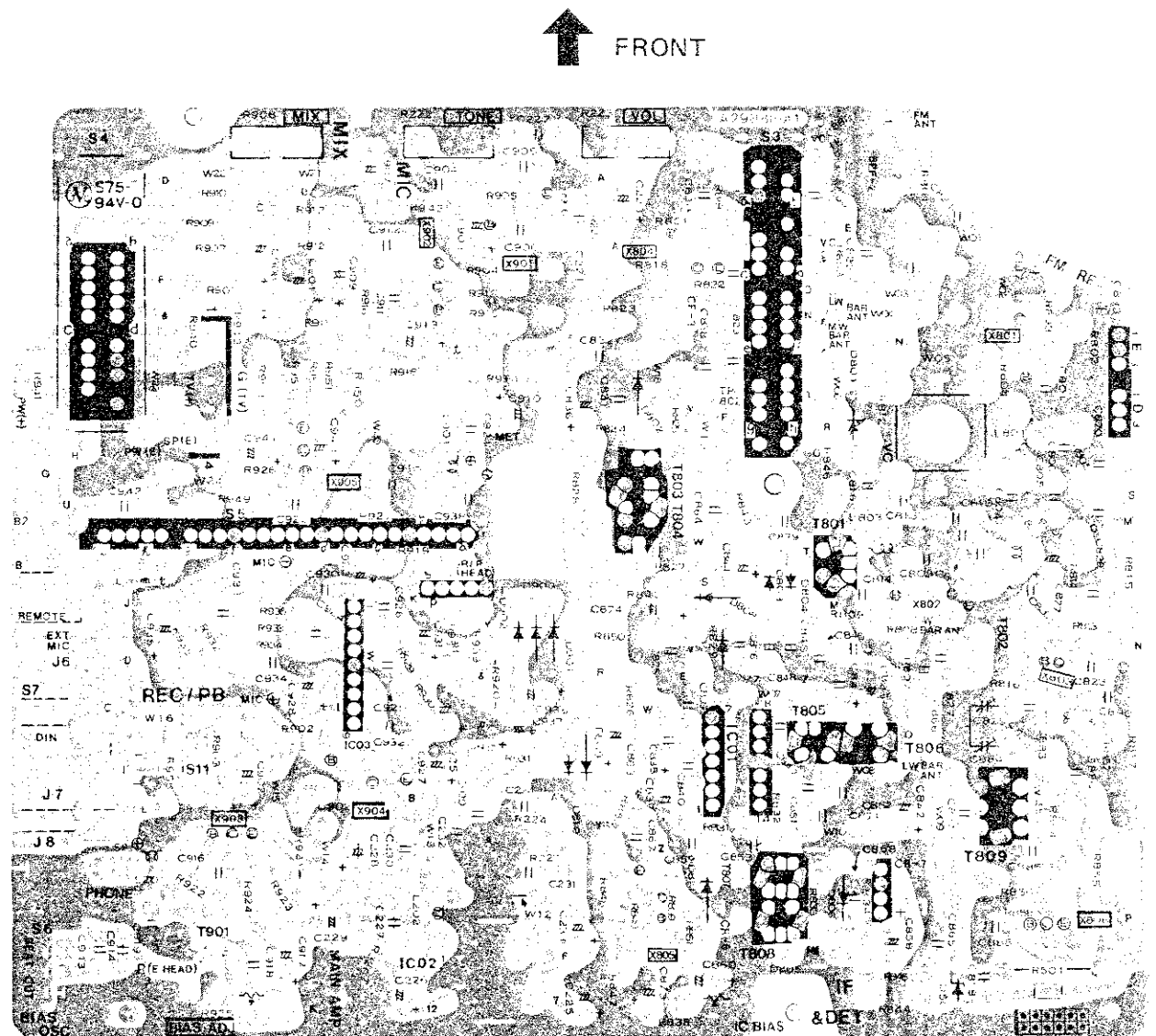

RADIO AMPLIFIER CIRCUIT

BASINGS OF TRANSISTORS AND ICs

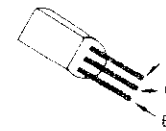

- 2SC1360
- 2SC1685
- 2SA564 H
- 2SC18904 E, F
- 2SC458 C
- 2SC1906
- 2SC2001 K, L
- 2SC945L U
- 2SC536 F

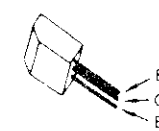

- 2SC454 B, C
- 2SC456 B, C
- 2SA673 C, D
- 2SC1213A
- 2SC460 C
- 2SA844 C
- 2SC632 L
- 2SC929 D

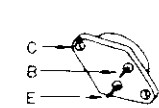

- 2SC1106A
- 2SC1454
- 2SC299
- 2SC1413A
- 2SC1942
- 2SC1104
- 2SC1304
- 2SC821

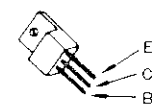

- 2SC1107 K, L
- 2SC1446 R, L
- 2SD478
- 2SB568
- 2SC1505
- 2SD401A
- 2SD546
- 2SD401
- 2SB548
- 2SC1929
- 2SD476
- 2SB566 C, D
- 2SD668A B, C
- 2SD476 C, D
- 2SC1061

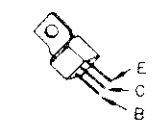

- 2SC1514
- 2SC1514W
- 2SC1514VC

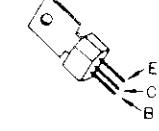

- 2SC1520 K, L

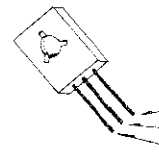

- 2SC1449 C, D

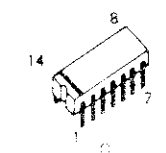

- 2SC1514
- 2SC1514W
- 2SC1514VC

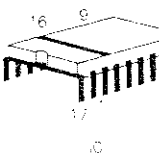

- 2SC1520 K, L

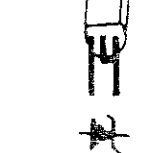

- 2SC1449 C, D

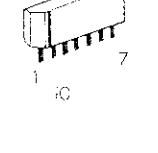

- 2SC1514
- 2SC1514W
- 2SC1514VC

4-P0574J

12. PACKING DIAGRAM

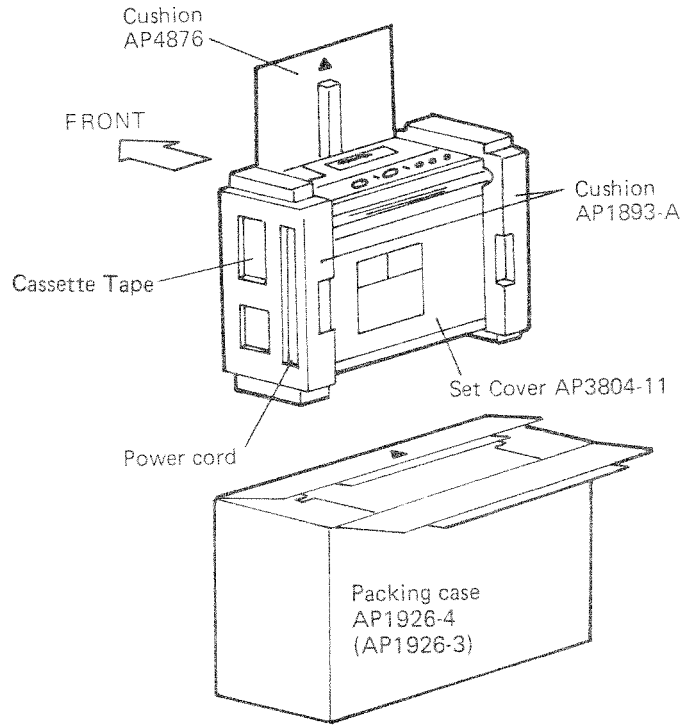

Fig. 68
() for CX-500EU

IN PACK MATERIALS

Instruction Book	CX-500GB-1B (CX-500EU-1B)
Schematic Diagram	CX500GB, EU-HSA
Warranty Card	BT-20013C (CX-500GB only)
Safety Tips	BT-20021 (BT-20033)
Power Cord	AX49384-R (AX49383-R)
Cassette Tape	BTC-606
Mag. Earphone	QME1308-004
Short Plug	V04056-1
Battery Tube	A38384

() for CX-500EU

13. OPTICAL ACCESSORIES

Carrying Case	CC-20E
Rechargeable Battery Pack	CB-15E
Auto-Plug (12V)	AP-23 (with 5A Fuse)