

Schematic Diagram..... Model SU-7700/SU-7700K

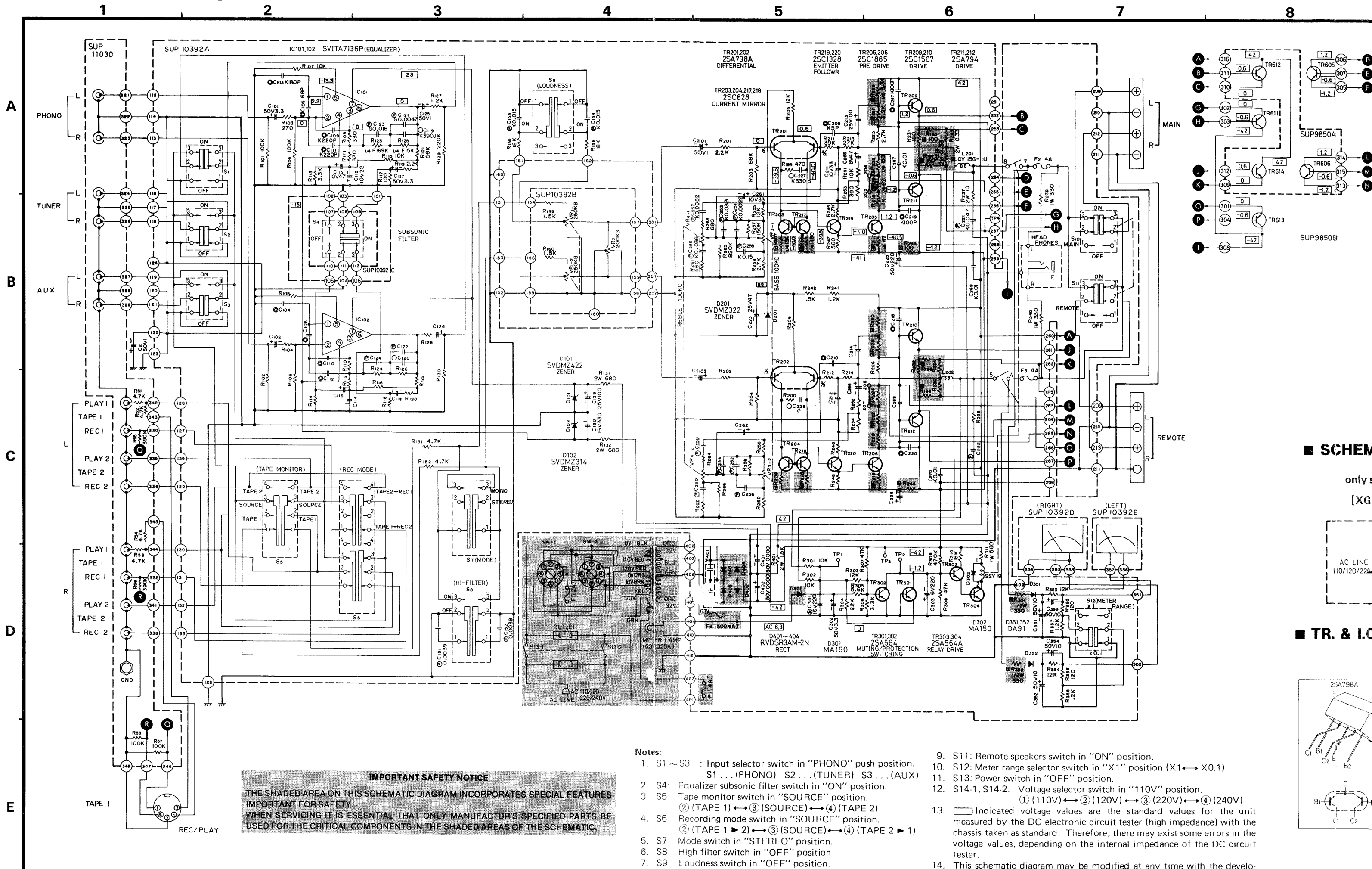

■ SCHEMATIC DIAGRAMS OF POWER SOURCE

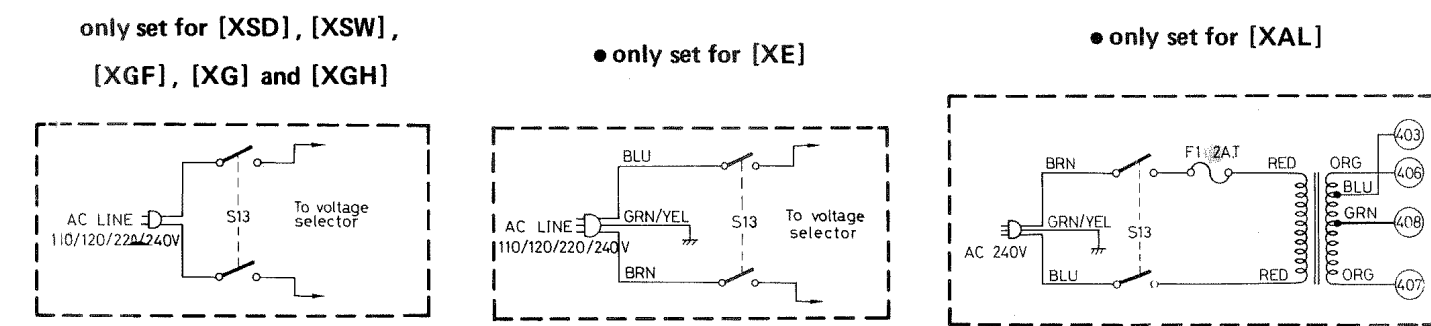

■ TR. & I.C. TERMINAL GUIDE

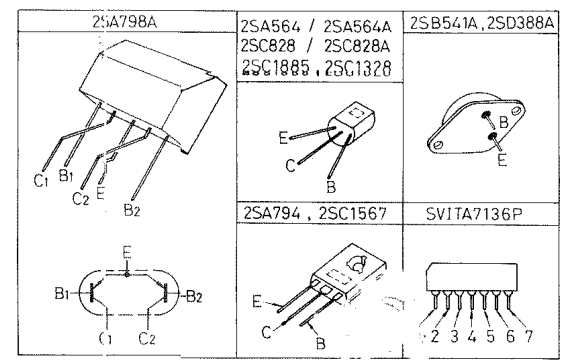

■ BLOCK DIAGRAM OF INTEGRATED CIRCUIT

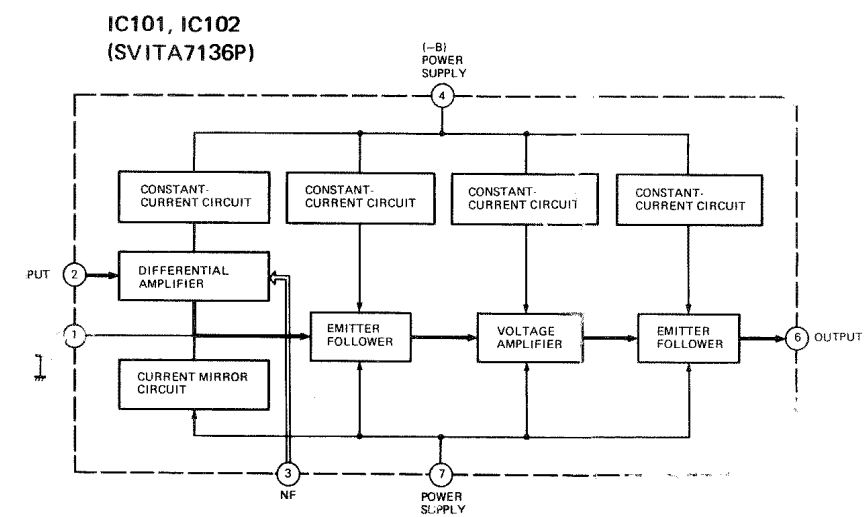

- Notes:
- S1 ~ S3 : Input selector switch in "PHONO" push position. S1... (PHONO) S2... (TUNER) S3... (AUX)
 - S4: Equalizer subsonic filter switch in "ON" position.
 - S5: Tape monitor switch in "SOURCE" position. ② (TAPE 1) ↔ ③ (SOURCE) ↔ ④ (TAPE 2)
 - S6: Recording mode switch in "SOURCE" position. ② (TAPE 1 ▶) ↔ ③ (SOURCE) ↔ ④ (TAPE 2 ▶ 1)
 - S7: Mode switch in "STEREO" position.
 - S8: High filter switch in "OFF" position.
 - S9: Loudness switch in "OFF" position.
 - S10: Main speakers switch in "ON" position.
 - S11: Remote speakers switch in "ON" position.
 - S12: Meter range selector switch in "X1" position (X1 ↔ X0.1)
 - S13: Power switch in "OFF" position.
 - S14-1, S14-2: Voltage selector switch in "110V" position. ① (110V) ↔ ② (120V) ↔ ③ (220V) ↔ ④ (240V)
 - Indicated voltage values are the standard values for the unit measured by the DC electronic circuit tester (high impedance) with the chassis taken as standard. Therefore, there may exist some errors in the voltage values, depending on the internal impedance of the DC circuit tester.
 - This schematic diagram may be modified at any time with the development of new technology.

IMPORTANT SAFETY NOTICE
THE SHADED AREA ON THIS SCHEMATIC DIAGRAM INCORPORATES SPECIAL FEATURES IMPORTANT FOR SAFETY. WHEN SERVICING IT IS ESSENTIAL THAT ONLY MANUFACTURER'S SPECIFIED PARTS BE USED FOR THE CRITICAL COMPONENTS IN THE SHADED AREAS OF THE SCHEMATIC.