

Service Manual

Stereo Integrated Amplifier

Amplifier

SU-610

Color

(S) Silver Type
(K) Black Type



Area

Country Code	Areas	Color
(E)	Continental Europe	(K) (S)
(EB)	Great Britain	(K) (S)
(EG)	F.R. Germany	(K) (S)
(GC)	Asia, Latin America, Middle Near East and Africa	(K)
(GN)	Oceania	(K)

SPECIFICATIONS

(DIN 45 500)

20 Hz~20 kHz continuous power output both channels driven	2 × 30 W (8 Ω)
1 kHz continuous power output both channels driven (THD: 1%)	2 × 38 W (8 Ω) 2 × 50 W (4 Ω)
63 Hz~12.5 kHz continuous power output both channels driven (0.7%)	2 × 35 W (8 Ω) 2 × 45 W (4 Ω)
Total harmonic distortion	
rated power at 20 Hz~20 kHz	0.07 % (8 Ω)
rated power at 1 kHz	0.02 % (8 Ω)
half power at 20 Hz~20 kHz	0.05 % (8 Ω)
half power at 1 kHz	0.02 % (8 Ω)
Intermodulation distortion	
rated power at 50 Hz: 7 kHz = 4:1, SMPTE, 8 Ω	0.07 %
Residual hum and noise	1 mV
Damping factor	40 (8 Ω), 20 (4 Ω)
Headphones output level and impedance	450 mV/330 Ω
Load impedance	
A or B	4 Ω~16 Ω
A and B	8 Ω~16 Ω
Input sensitivity and impedance	
PHONO	2.5 mV/47 kΩ
TUNER, CD, AUX, TAPE/ADAPT	150 mV/18 kΩ
Phono maximum input voltage (IHF '66, 1 kHz, RMS)	150 mV
S/N	
rated power (4 Ω)	
PHONO	76 dB (IHF '66: 77 dB)
TUNER, CD, AUX, TAPE/ADAPT	91 dB (IHF '66: 98 dB)
-26 dB power (4 Ω)	
PHONO	68 dB
TUNER, CD, AUX, TAPE/ADAPT	70 dB
50 mW power (4 Ω)	
PHONO	64 dB
TUNER, CD, AUX, TAPE/ADAPT	64 dB

Frequency response

PHONO

RIAA standard curve

±1 dB (30 Hz~15 kHz)

TUNER, CD, AUX, TAPE/ADAPT

3 Hz~80 kHz (-3 dB)

+0 dB, -0.3 dB (20 Hz~20 kHz)

Tone controls

BASS

50 Hz, +10 dB, -10 dB

TREBLE

20 kHz, +10 dB, -10 dB

Loudness control (volume at -30 dB)

50 Hz, +9 dB

Output voltage

TAPE/ADAPT REC OUT

150 mV

Channel balance, CD 250 Hz~6,300 Hz

±1 dB

Channel separation, CD 1 kHz

50 dB

■ GENERAL

Power consumption

300 W

Power supply

For Great Britain and Oceania

AC 50 Hz/60 Hz, 240 V

For Continental Europe and F.R. Germany

AC 50 Hz/60 Hz, 220 V

For others

AC 50 Hz/60 Hz, 110 V/127 V/220 V/240 V

Dimensions (W × H × D)

430 × 125 × 320 mm

(16-15/16" × 4-15/16" × 12-5/8")

Weight

For Great Britain and Oceania

6.5

For Continental Europe, F.R. Germany and

Notes:

1. Specifications are subject to change.
2. Weight and dimensions are approximate.
3. Total harmonic distortion is measured with a standard analyzer.

Technics

Matsus'

■ CONTENTS

	Page		Page
BEFORE REPAIR	2	SCHEMATIC DIAGRAM	10~12
PROTECTION CIRCUITRY	2	PRINTED CIRCUIT BOARDS	13~16
ACCESSORIES	2	TERMINAL GUIDE OF IC'S, TRANSISTORS AND DIODES	16
LOCATION OF CONTROLS	3	WIRING CONNECTION DIAGRAM	17
CONNECTIONS	4, 5	REPLACEMENT PARTS LIST	18, 21, 22
DISASSEMBLY INSTRUCTIONS	6~8	EXPLODED VIEW	19, 20
BLOCK DIAGRAM	9		

■ BEFORE REPAIR

- (1) Turn off the power supply. Using a 10Ω, 5 W resistor connect both ends of power supply capacitors (C705, C706, 4700 μF) in order to discharge the voltage.
- (2) Before turning the power supply on, after completion of repair, slowly apply the primary voltage by using a power supply voltage controller to make sure that the consumed current at 50 Hz/60 Hz in NO SIGNAL mode should be shown below with respect to supply voltage 110 V/127 V/220 V/240 V.

Power supply voltage	AC 110 V	AC 120 V	AC 220 V	AC 240 V
Consumed current 50 Hz	100~330 mA	90~310 mA	50~165 mA	45~150 mA
Consumed current 60 Hz	80~182 mA	72~166 mA	40~132 mA	36~120 mA

■ PROTECTION CIRCUITRY

The protection circuitry may have operated if either of the following conditions is noticed:

- *No sound is heard when the power is switched ON.
- *Sound stops during a performance.

The function of this circuitry is to prevent circuitry damage if, for example, the positive and negative speaker connection wires are "shorted", or if speaker systems with an impedance less than the indicated rated impedance of this unit are used.

If this occurs, follow the procedure outlined below:

1. Switch OFF the power.
2. Determine the cause of the problem and correct it.
3. Switch ON the power once again.

Note:

When the protection circuitry functions, the unit will not operate unless the power is first switched OFF and then ON again.

■ ACCESSORIES

●AC power supply cord	1	●Attachment AC plug	1
RJA0004	For (GC) area only.	SJP9215	For (GC) area only.
SJA173	For (GN) area only.		
SJA193	For (EB) area only.		
SFDAC05E03	For others.		

LOCATION OF CONTROLS

•Front Panel

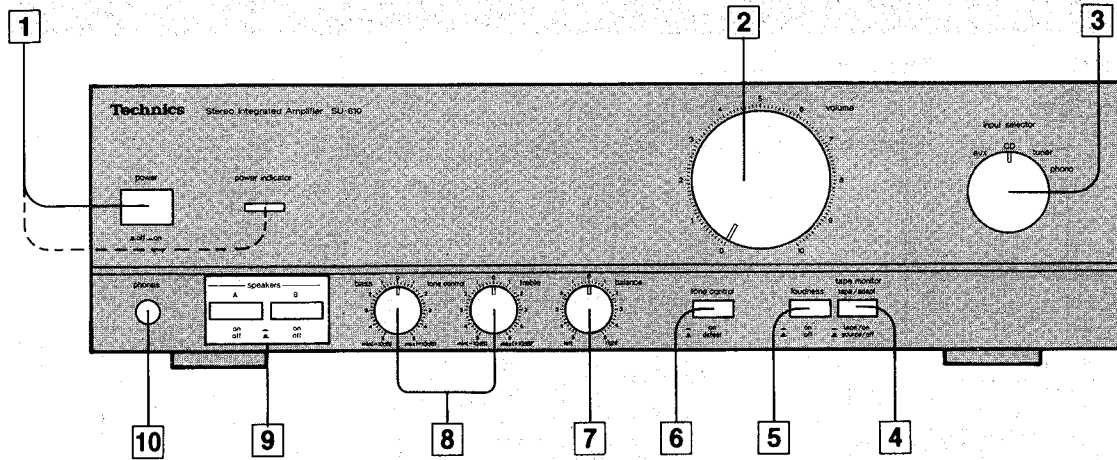

1 Power switch/indicator (power)

2 Volume control (volume)

3 Input selector (input selector)

This selector is used to select the sound source to be heard, such as a disc, radio broadcast, etc.

4 Tape-monitor selectors (tape monitor)

The left selector is used to playback or monitor the sound from a tape deck 1 (or DAT) or to record from tape deck 1,(or DAT) to 2.

The right selector is used to playback or monitor the sound from a tape deck 2 or to listen to the sound processed by a graphic equalizer.

5 Loudness switch (loudness)

This switch is used when listening to music at a low volume level. Auditory perception of sound in the low frequency range falls off at low volume, but when the switch is set to the "on" position, this deficiency is compensated for, so that the full impact of the musical performance can be enjoyed.

6 Tone control switch (tone control)

This switch is used to turn the tone control circuit (bass, treble) on or off.

7 Balance control (balance)

This control is used to adjust the left/right volume balance.

8 Tone controls (bass/treble)

The bass control is used to adjust the low-frequency sound range, and the treble control is used to adjust the high-frequency sound range.

9 Speaker selectors (speakers)

These selectors are used to turn the speaker systems on and off.

10 Headphones jack (phones)

•Rear Panel

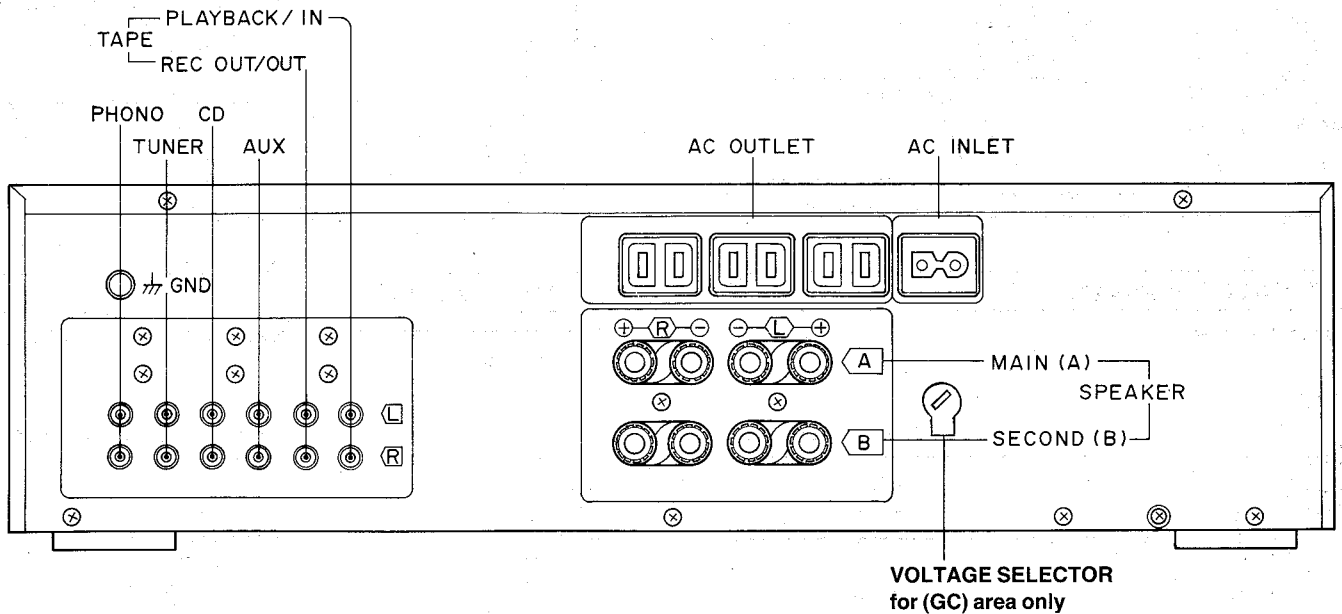

*Phono input capacitance is about 270 pF for EG area (about 100 pF for other areas).

CONNECTIONS

System configurations

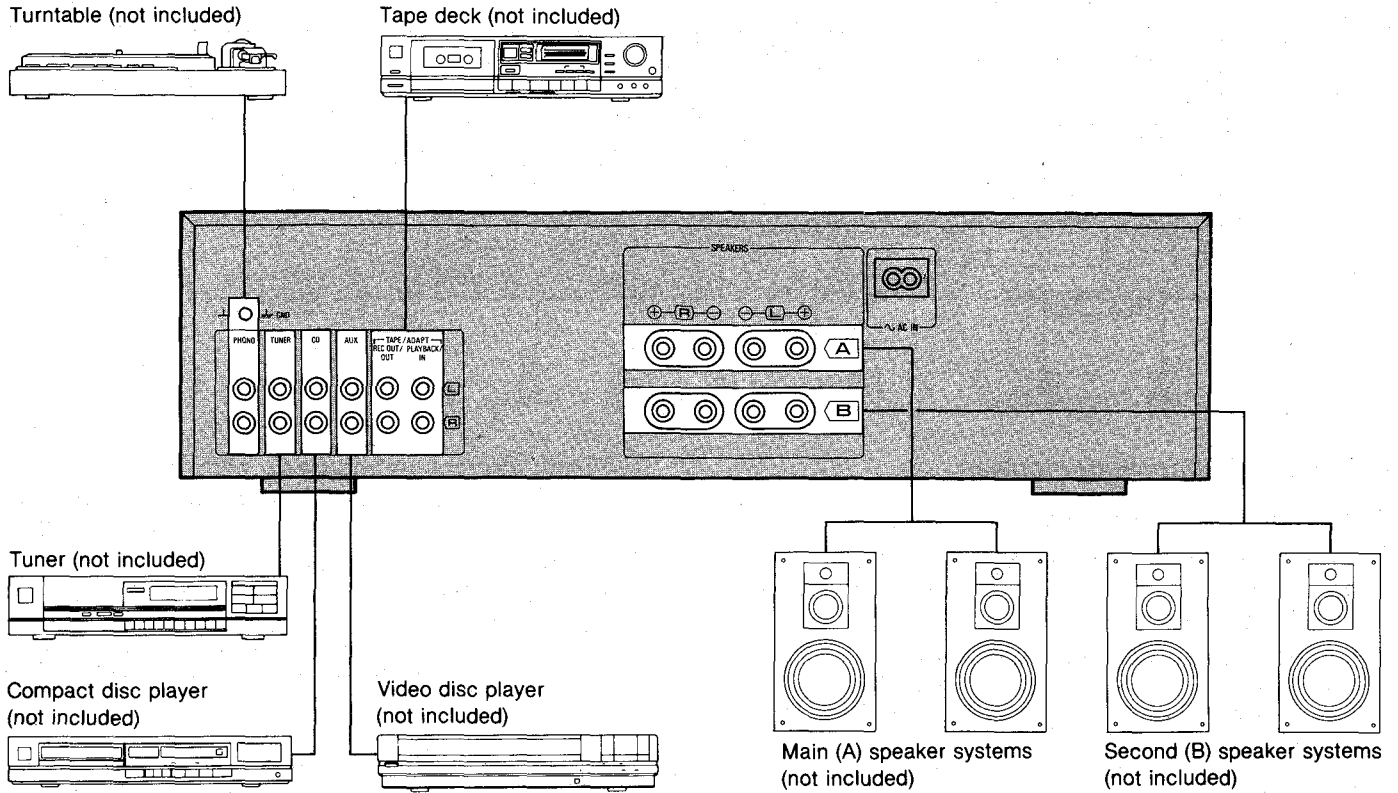

To connect to each terminals

Make connections to each component in the system by using stereo connection cables (not included).

"PHONO" terminals

Connect a turntable.

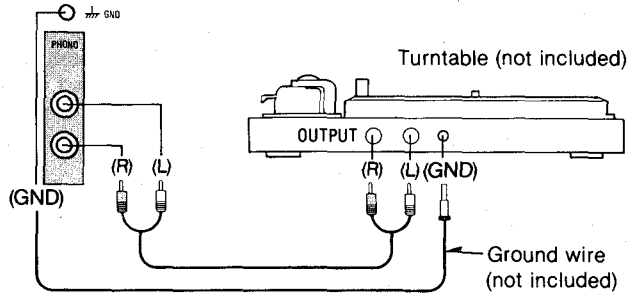

"CD" terminals

Connect a compact disc player.

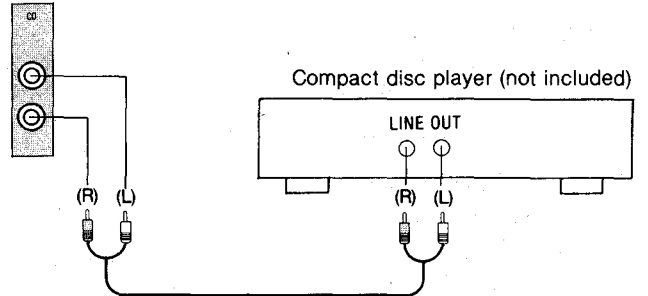

"TUNER" terminals

Connect a tuner.

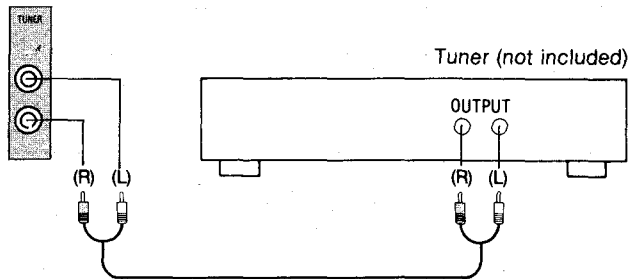

"AUX" terminals

Connect a component such as a video disc player (audio only connectable), etc.

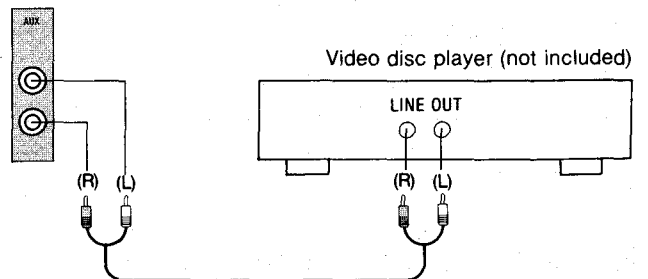

"TAPE/ADAPT" terminals

Connect a tape deck or a graphic equalizer.

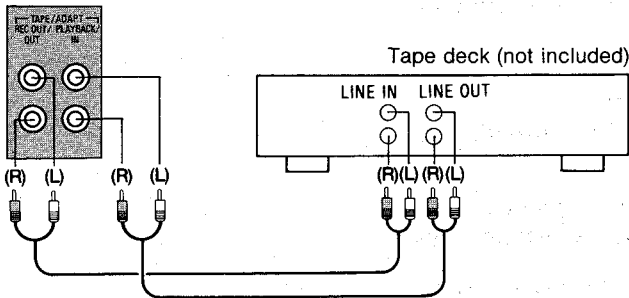

To connect the AC power supply cord (included)

Connect the AC power supply cord (included) after all other cables and cords are connected.

Note:

Configuration of AC power supply cord differs according to area.

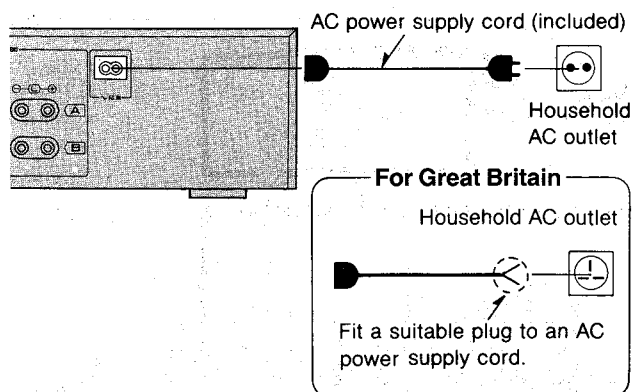

Connection to speaker systems

One pair of speaker systems can be connected to the "A" terminals of this unit and one pair to the "B" terminals.

Load impedance

- When only the "A" or only the "B" terminals are used: 4-16 ohms
- When both the "A" and the "B" terminals are used simultaneously: 8-16 ohms

To connect main (A) and/or second (B) speaker systems

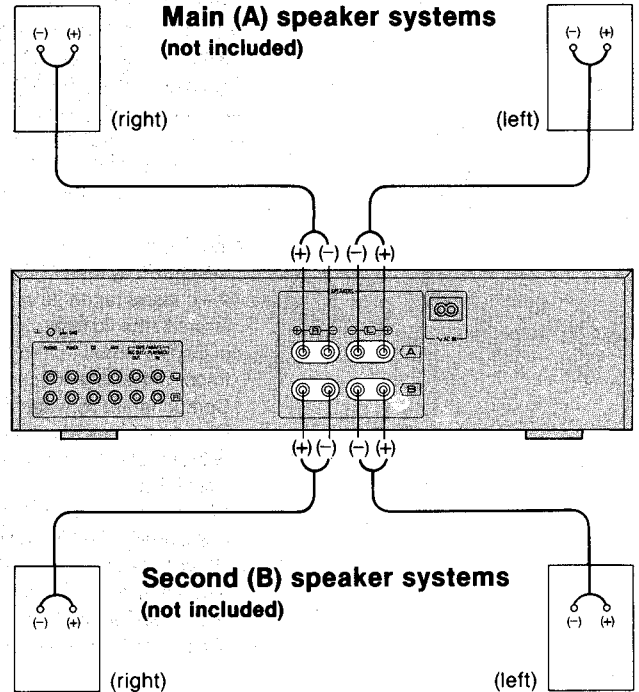

To connect cords to terminals

- ① Strip off the outer covering, and twist the center conductor.

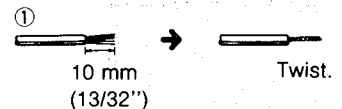

- ② Turn 5 or 6 times.

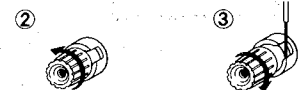

- ③ Insert the wire and tighten screw completely. Pull the wire to assure a proper connection.



Note: Be sure to only connect positive (+) cords to positive (+) terminals, and negative (-) cords to negative (-) terminals.

Note:

To prevent damage to circuitry, never short-circuit the plus (+) and minus (-) speaker terminals.

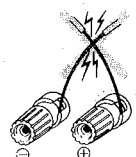

DISASSEMBLY INSTRUCTIONS

"ATTENTION SERVICER"

Some chassis components may have sharp edges. Be careful when disassembling and servicing.

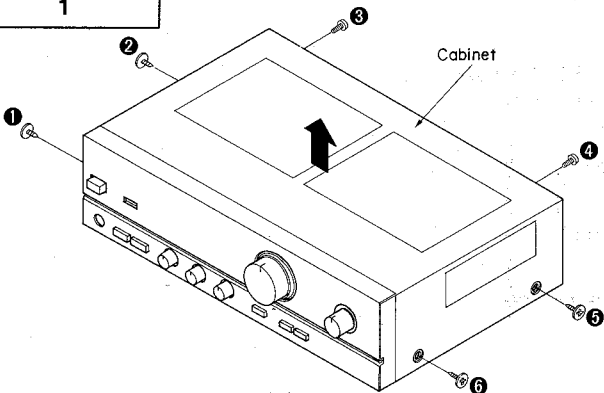
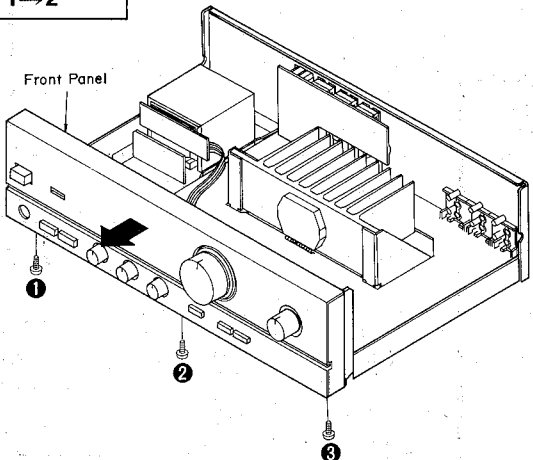
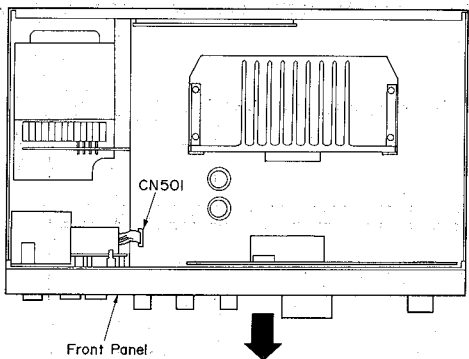
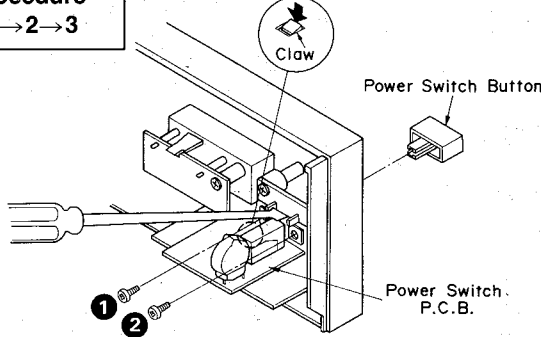
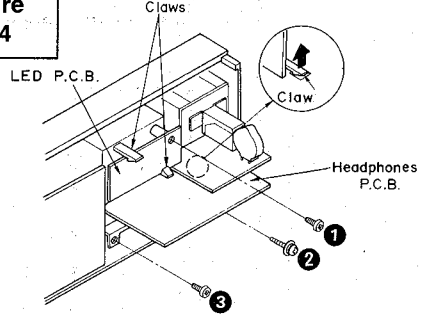
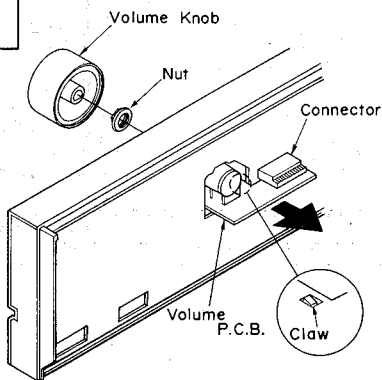
<p>Ref. No. 1</p>	<p>Removal of the cabinet</p>	<p>Ref. No. 2</p>	<p>Removal of the front panel</p>
<p>Procedure 1</p>	 <p>● Remove the 6 screws (①~⑥).</p>	<p>Procedure 1→2</p>	
<p>Ref. No. 3</p>	<p>Removal of the power switch P.C.B.</p>	<p>1. Remove the 3 screws (①~③).</p>	 <p>2. Remove the 1 flat cable (CN501). 3. Remove the front panel in the direction of the arrow.</p>
<p>Procedure 1→2→3</p>	 <p>1. Remove the power switch button by pushing it from behind the front panel. 2. Remove the 2 screws (①, ②). 3. Release the 1 claw.</p>	<p>Ref. No. 4</p>	<p>Removal of the LED P.C.B. and headphones P.C.B.</p>
<p>Procedure 1→2→4</p>	 <p>Removal of the LED P.C.B. 1. Remove the 1 screw (①). 2. Release the 2 claws.</p> <p>Removal of the headphones P.C.B. 1. Remove the 2 screws (②, ③). 2. Release the 1 claw.</p>	<p>Ref. No. 5</p>	<p>Removal of the volume P.C.B.</p>
		<p>Procedure 1→2→5</p>	 <p>1. Pull out the volume knob. 2. Remove the nut. 3. Release the 1 claw.</p>

Ref. No.
6

Removal of the operation P.C.B.

Procedure
1→2→5→6

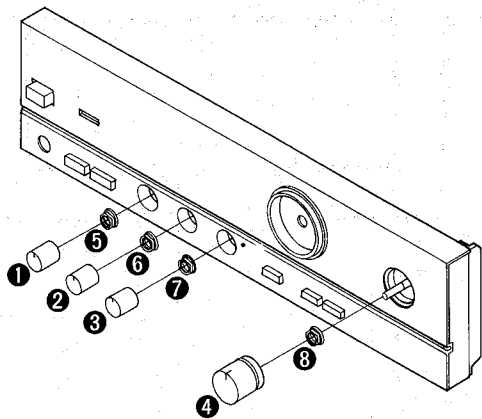

1. Pull out the 4 knobs (1~4).
2. Remove the 4 nuts (5~8).

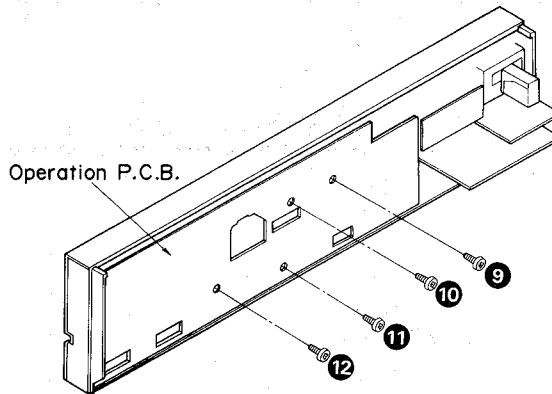

3. Remove the 4 screws (9~12).

• Use a wrench of the dimensions shown in the illustration above to remove nuts.

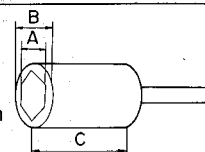

Ref. No.
7

Checking of the main P.C.B.

Procedure
1→7

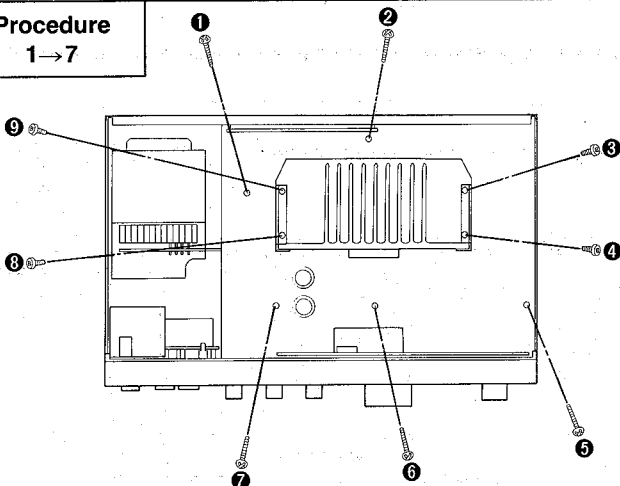

1. Remove the 9 screws (1~9).

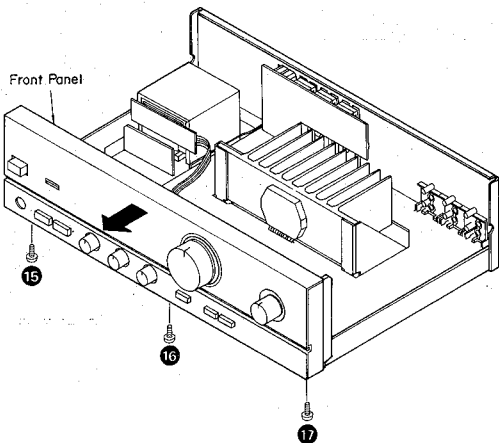

3. Remove the 3 screws (15~17).
4. Remove the front panel.

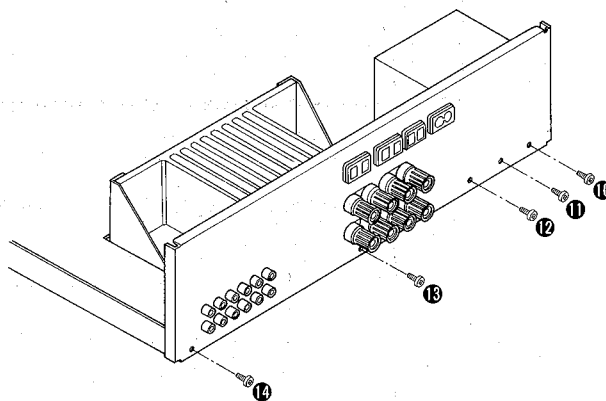

2. Remove the 5 screws (10~14).

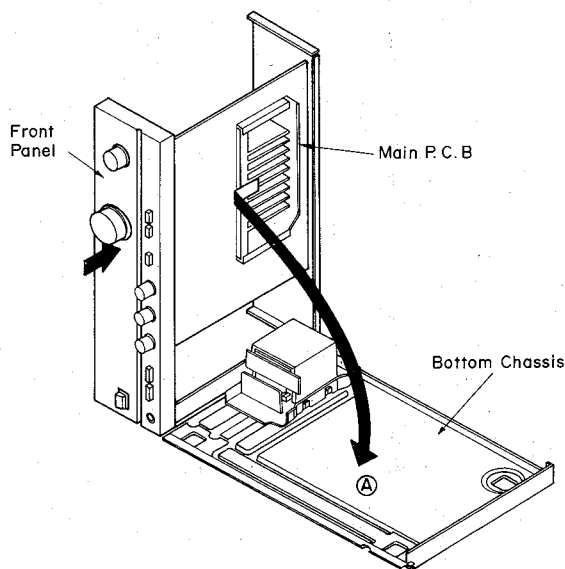

5. Remove the bottom chassis in the direction of the arrow (A).
6. Reinstall the front panel to the main P.C.B.

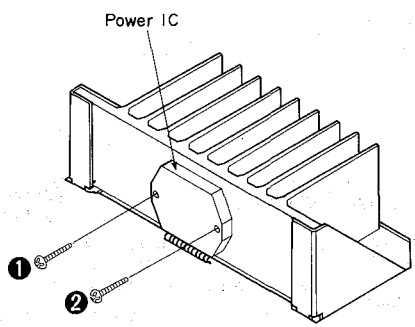
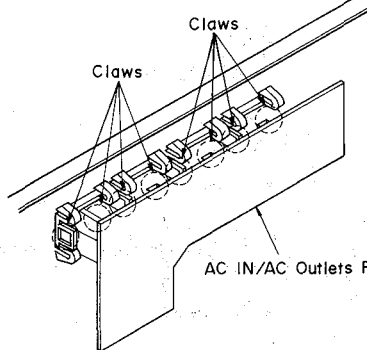
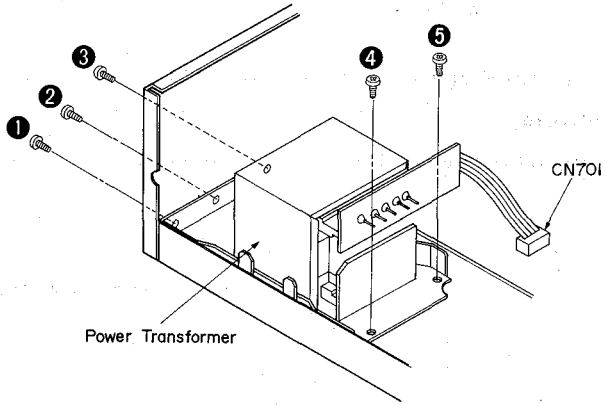
<p>Ref. No. 8</p>	<p>Removal of the power IC</p>	<p>Ref. No. 9</p>	<p>Removal of the AC IN/OUT P.C.B.</p>
<p>Procedure 1→7→8</p>	<p>1. Unsolder the power IC. 2. Remove the 2 screws (①, ②).</p>	<p>Procedure 1→9</p>	
 <p>●When mounting the power IC, apply silicon thermal compound (SZZOL15 or equivalent) to the rear of the power IC.</p>		 <p>●Release the 8 claws.</p>	
<p>Ref. No. 10</p>	<p>Removal of the power transformer</p>		
<p>Procedure 1→10</p>	<p>1. Remove the 1 flat cable (CN701). 2. Remove the 5 screws (①~⑤).</p>		
<p>1. Remove the 1 flat cable (CN701). 2. Remove the 5 screws (①~⑤).</p>			

●Replacement of the Foot.

1. Remove the 4 heat melted posts on the chassis with a pair of diagonal pliers or similar tool.
2. To mount the foot (RKA0009-1) on the chassis, melt the 4 posts with a soldering iron.

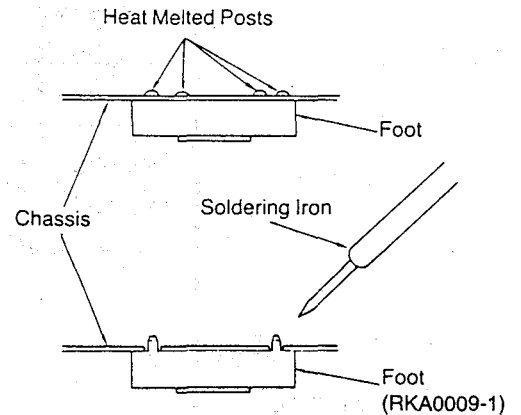

BLOCK DIAGRAM

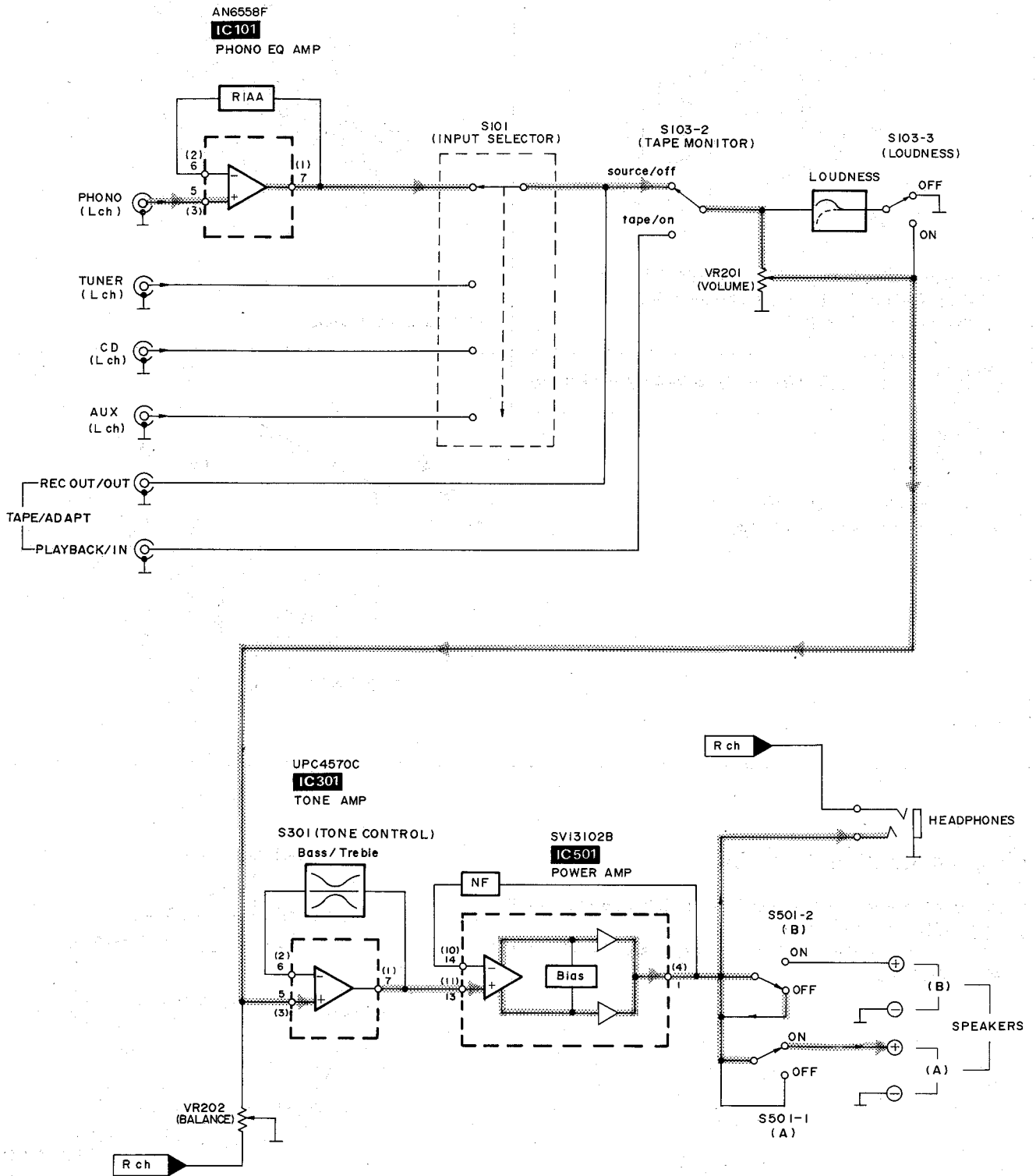

1 2 3 4 5 6 7 8 9 10

A B C D E F

A OPERATION CIRCUIT

B VOLUME CIRCUIT

D LED CIRCUIT

E HEADPHONES CIRCUIT

C MAIN CIRCUIT

F POWER SWITCH

G AC IN C

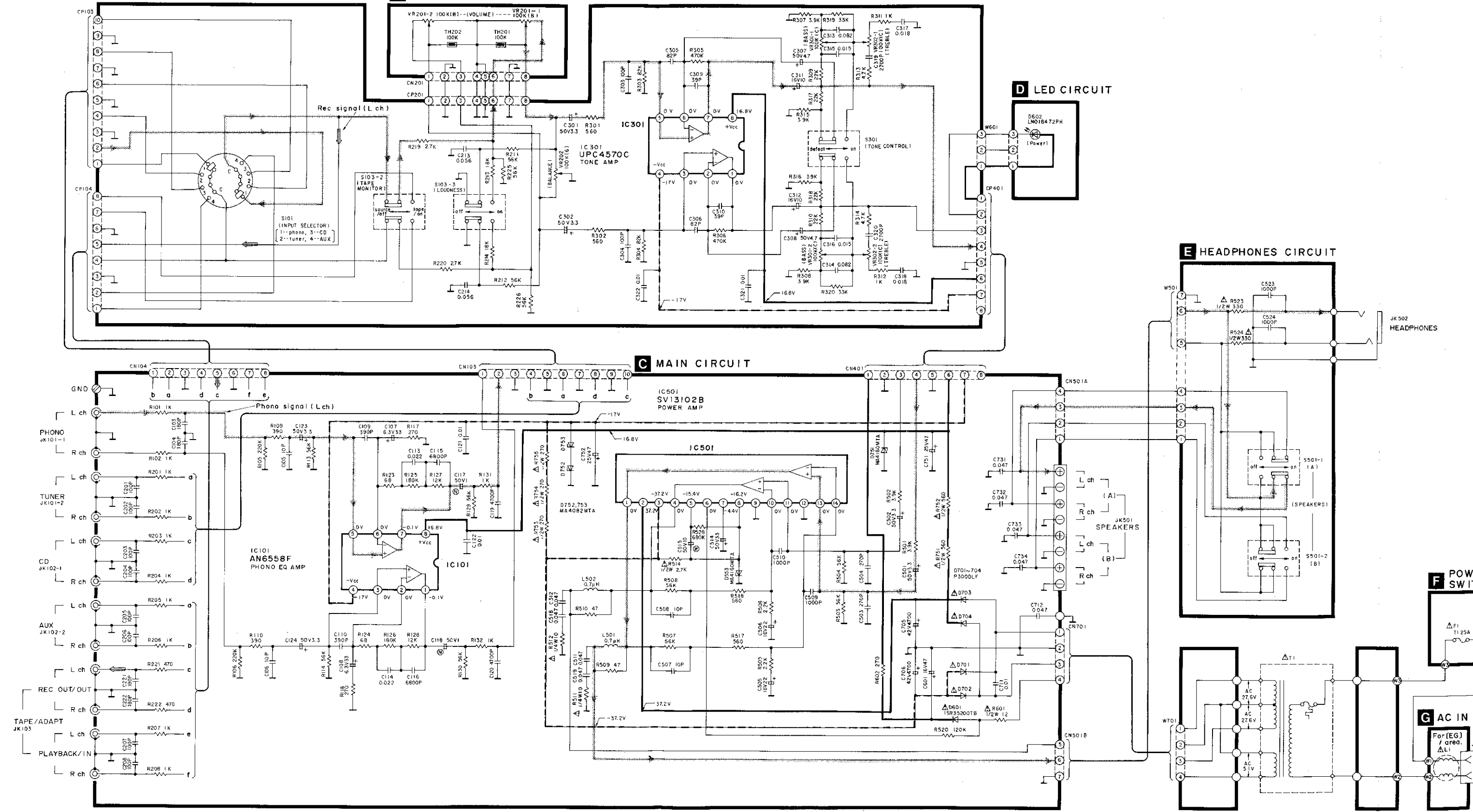

SCHEMATIC DIAGRAM

(Parts list on page 21, 22)

(This schematic diagram may be modified at any time with the development of new technology.)

Notes:

- S1 : Power switch in "on" position.
 - S2 : Voltage selector switch in "240 V" position.
(110 V/127 V/220 V/240 V)
For (GC) area only.
 - S101 : Input selector switch in "phono" position.
 - S103-1 : Tape-monitor select switch in "source/off" position.
(tape 2/on → source/off)
 - S103-2 : Tape-monitor select switch in "source" position.
(tape 1/DAT → source)
 - S103-3 : Loudness switch in "off" position.
 - S301 : Tone control switch in "defeat" position.
 - S501-1 : Speaker (A) switch in "on" position.
 - S501-2 : Speaker (B) switch in "off" position.
- : Positive voltage lines.
- - - : Negative voltage lines.
⊠ : Phono Signal (Lch)
⊡ : Recording Signal

●Indicated voltage values are the standard values for the unit measured by the DC electronic circuit tester (high-impedance) with the chassis taken as standard. Therefore, there may exist some errors in the voltage values, depending on the internal impedance of the DC circuit tester.

Important safety notice:

Components identified by Δ mark have special characteristics important for safety. When replacing any of these components, use only manufacturer's specified parts.

*Caution!

- IC and LSI are sensitive to static electricity.
- Secondary trouble can be prevented by taking care during repair.
- *Cover the parts boxes made of plastics with aluminum foil.
- *Ground the soldering iron.
- *Put a conductive mat on the work table.
- *Do not touch the legs of IC or LSI with the fingers directly.

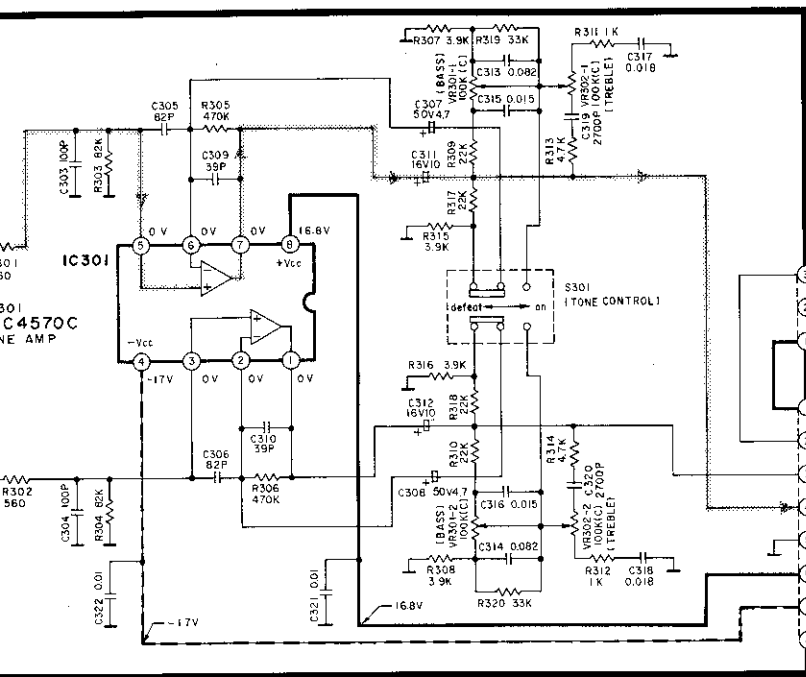

D LED CIRCUIT

E HEADPHONES CIRCUIT

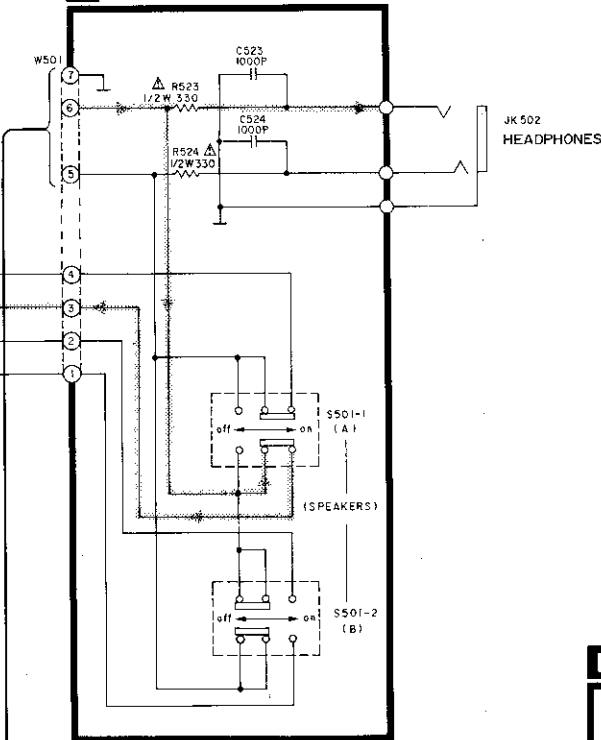

F POWER SWITCH CIRCUIT

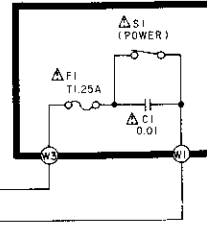

G AC IN CIRCUIT

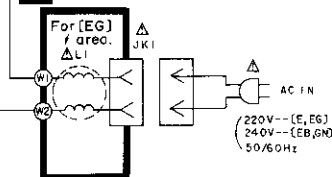

Power Source For (GC) area.

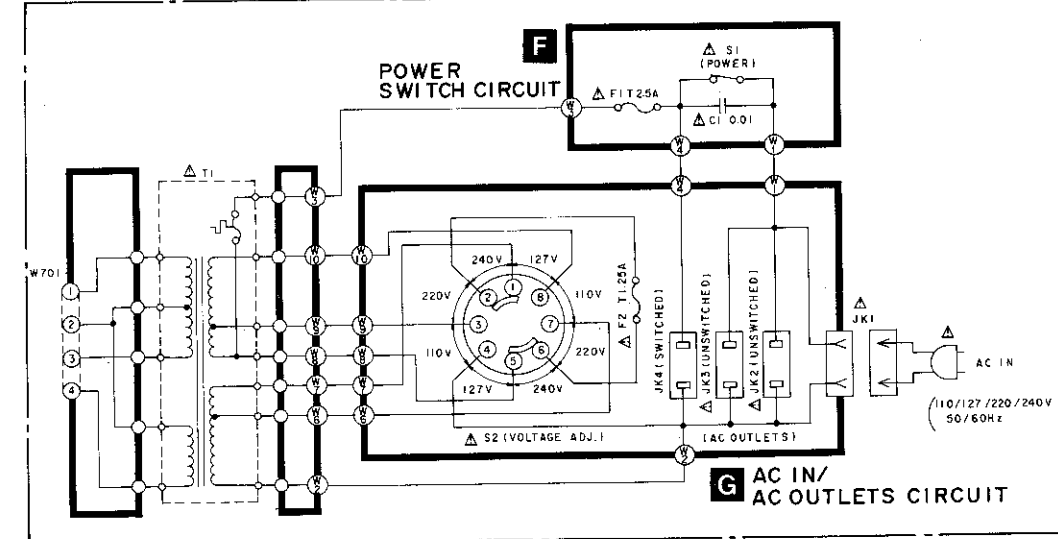

G AC IN/ AC OUTLETS CIRCUIT

PRINTED CIRCUIT BOARDS (Parts list on pages 21, 22)

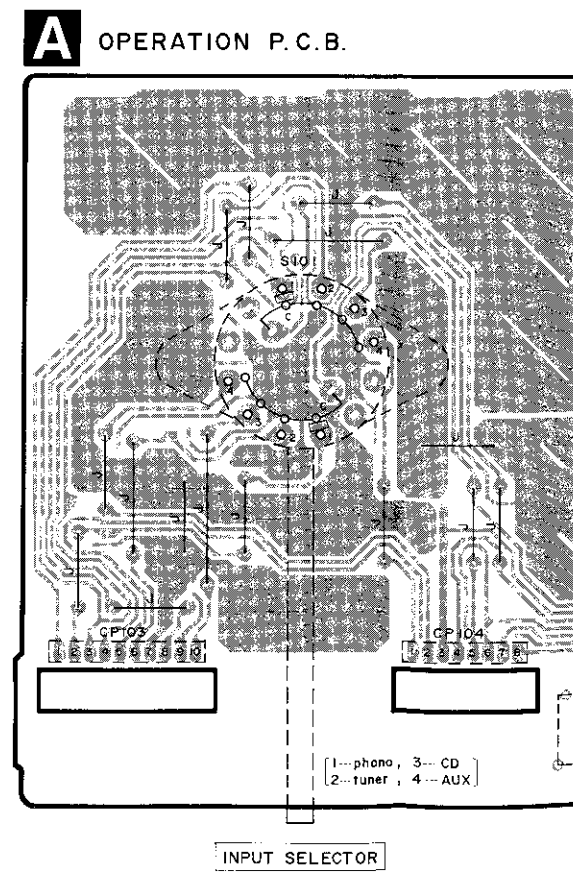
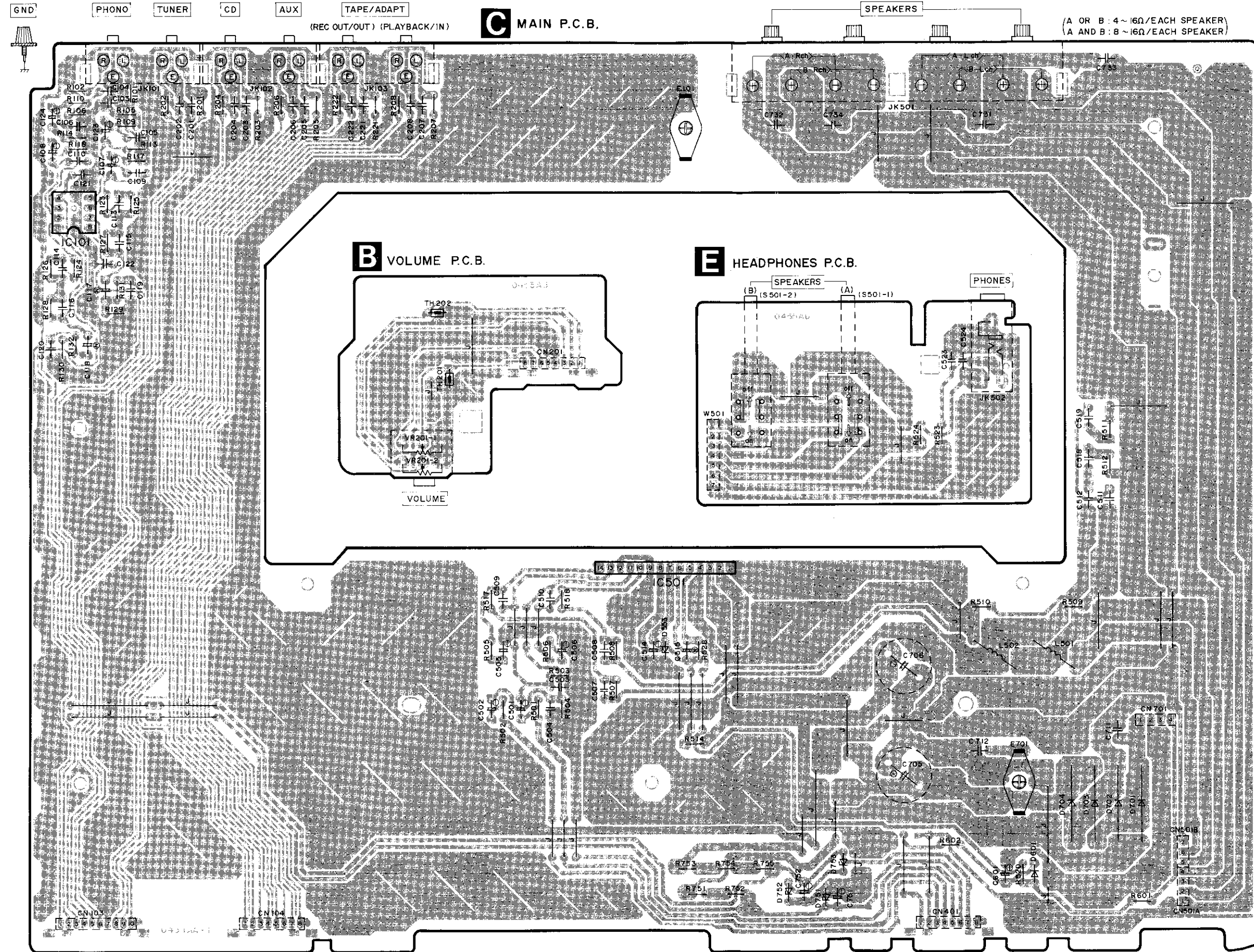

OR B : 4 ~ 16Ω/EACH SPEAKER)
AND B : 8 ~ 16Ω/EACH SPEAKER)

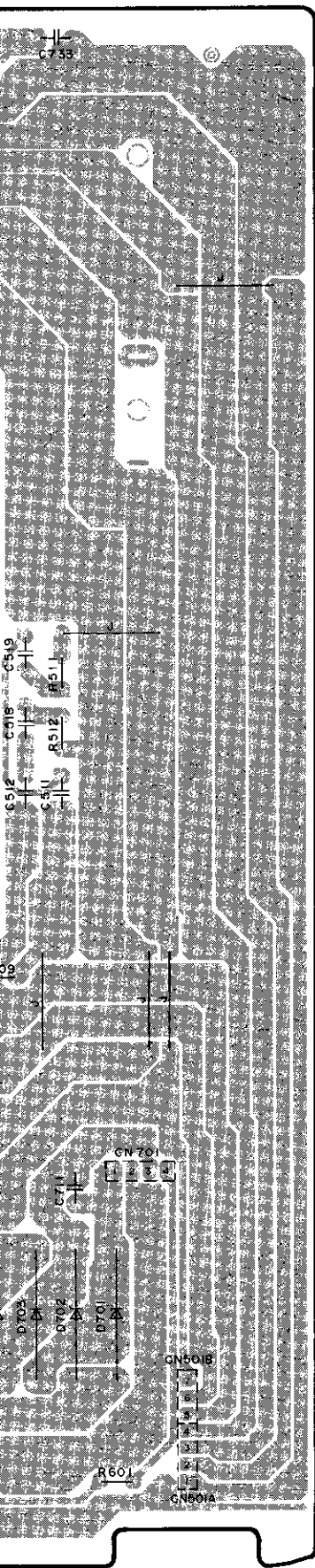

F POWER SWITCH P.C.B.

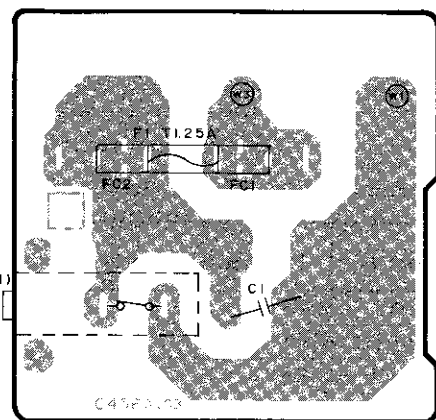

G AC IN P.C.B.

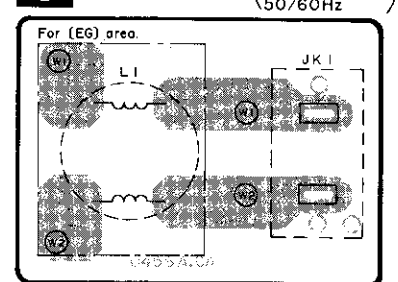

AC IN
220V---[E,EG]
240V---[EB,GN]
50/60Hz

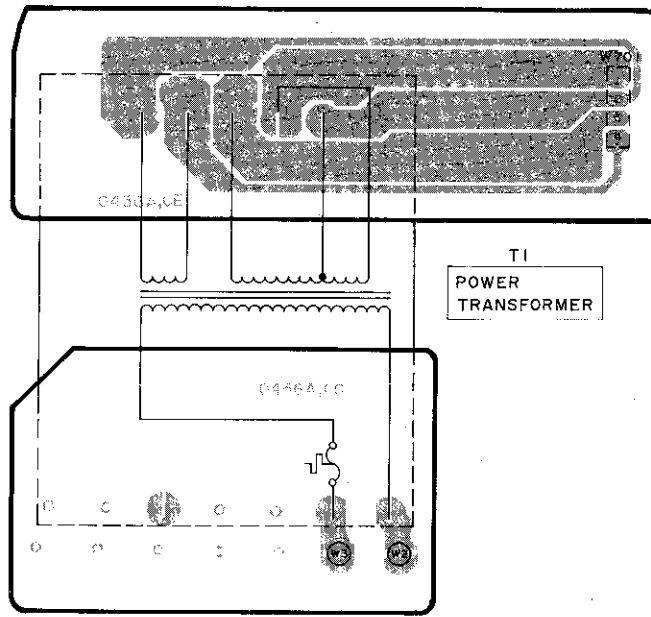

A OPERATION P.C.B.

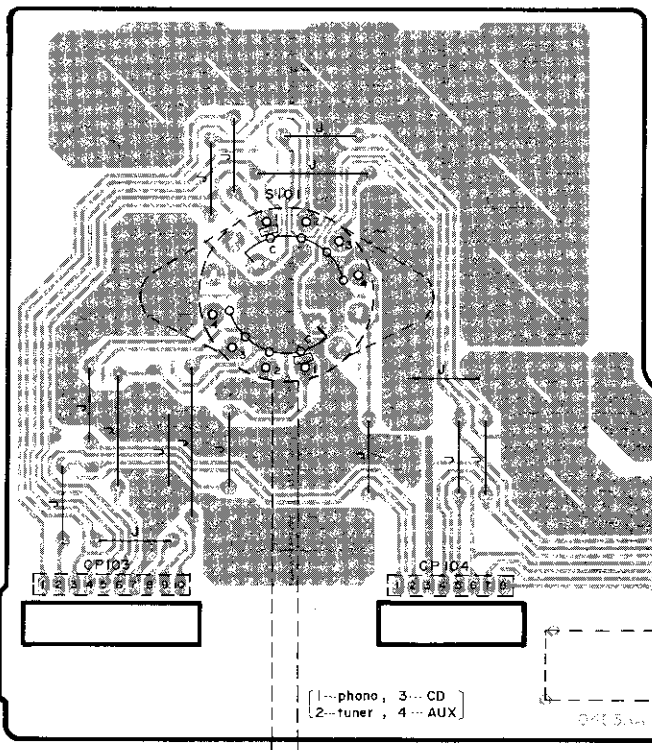

D LED P.C.B.

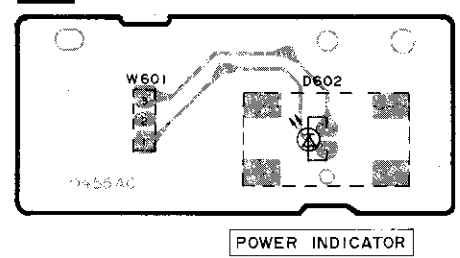

INPUT SELECTOR [1---phono, 3---CD, 2---tuner, 4---AUX] TAPE MONITOR LOUDNESS TONE CONTROL BALANCE TREBLE --- TONE CONTROL --- BASS

TERMINAL GU

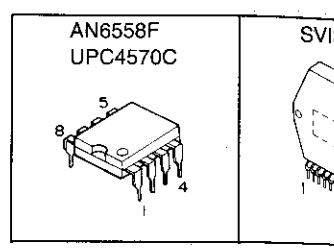

Power Source For [GC]

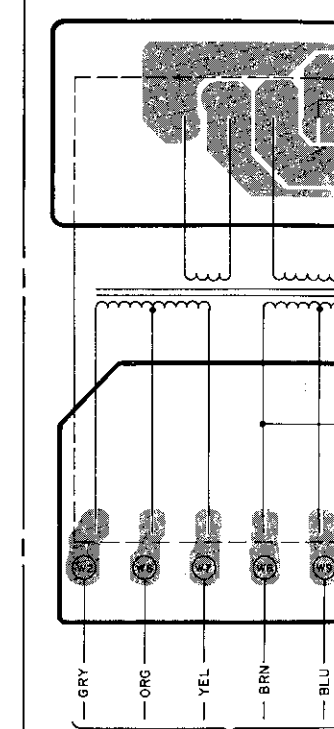

■ TERMINAL GUIDE OF IC'S, TRANSISTORS AND DIODES

<p>AN6558F UPC4570C</p>	<p>SVI3102B</p>	<p>1SR35200TB</p>	<p>MA4160MTA</p>	<p>MA4082MTA</p>	<p>P300DLF</p>	<p>LN018472PH</p>
-----------------------------	-----------------	-------------------	------------------	------------------	----------------	-------------------

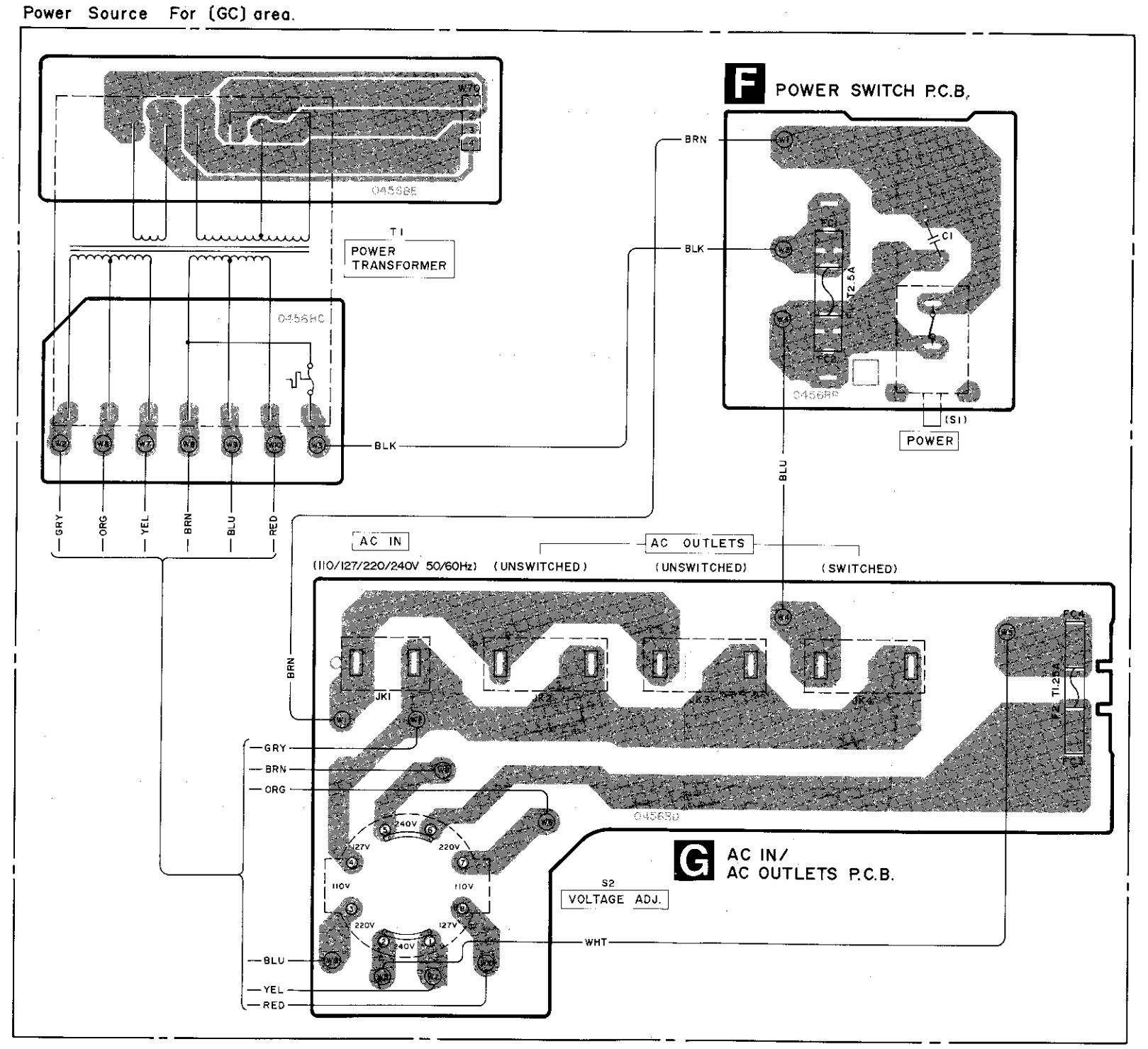
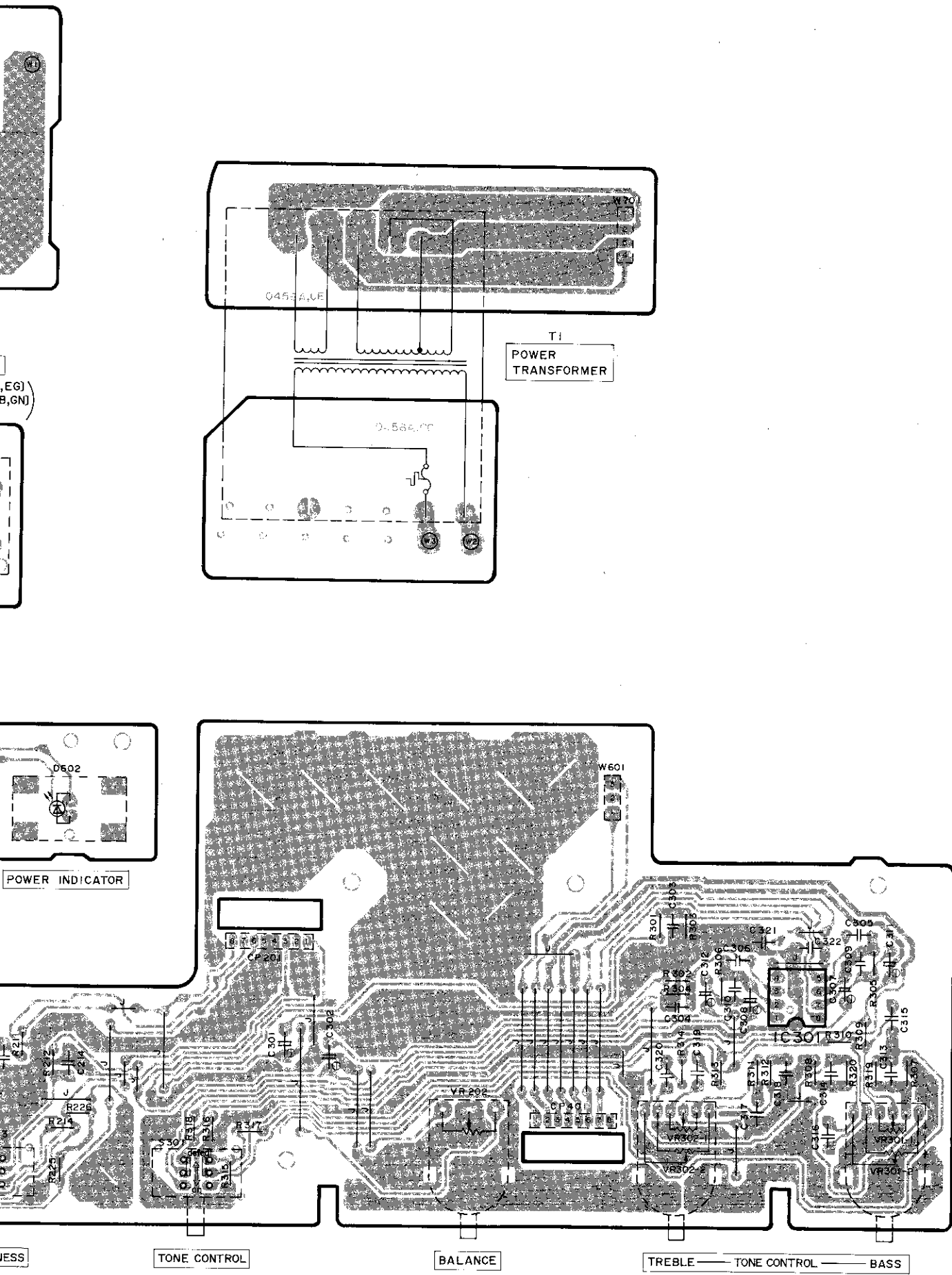

WIRING CONNECTION DIAGRAM

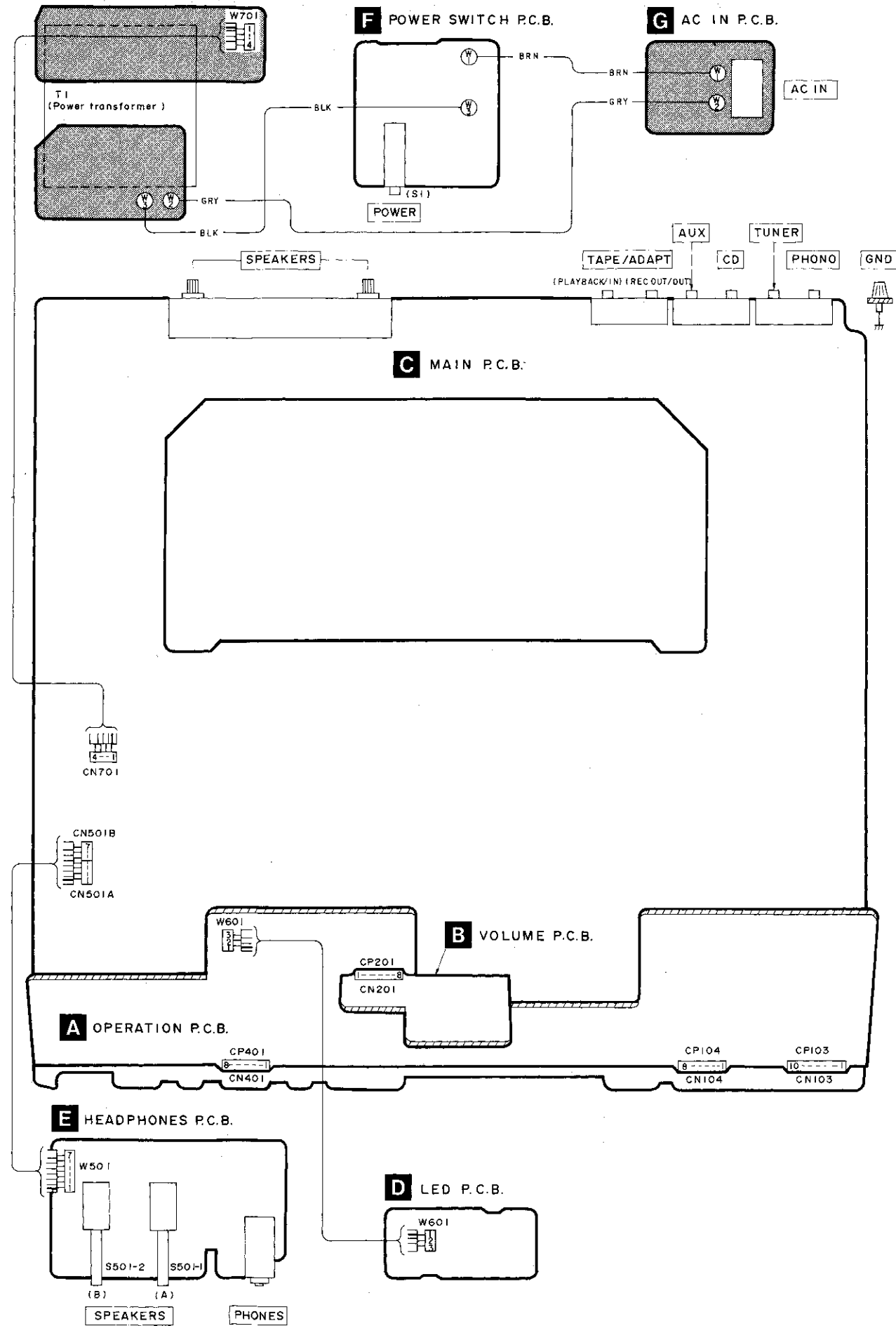

REPLACEMENT PARTS LIST

Notes: *Important safety notice:

Components identified by Δ mark have special characteristics important for safety. When replacing any of these components use only manufacturer's specified parts.

*The parenthesized indications in the Remarks columns specify the areas. (Refer to the cover page for area.)

Parts without these indications can be used for all areas.

**"K" mark parts are used for black type only.

**"S" mark parts are used for silver type only.

Parts other than "K" and "S" marked are used for all color types.

Ref. No.	Part No.	Part Name & Description	Remarks	Ref. No.	Part No.	Part Name & Description	Remarks
		CABINET PARTS		22	SNE2129	SCREW	S
1	RFKGU610E-K	FRONT PANEL ASS'Y	K	23	XTBS3+8JFZ1	SCREW	
1	RFKGU610E-S	FRONT PANEL ASS'Y	S	24	XTB3+8JFZ	SCREW	
2	RGK0098-K	ORNAMENT (LEFT)	K	25	SNE4021-1	NUT	
2	RGK0098-1S	ORNAMENT (LEFT)	S	26	XTB3+16JFZ	SCREW	
3	RGK0099-K	ORNAMENT (RIGHT)	K	27	XTB3+20J	SCREW	
3	RGK0099-1S	ORNAMENT (RIGHT)	S	29	XTWS3+8T	SCREW	
4	RGK0212-K	ORNAMENT (VOLUME)	K	30	SNE2123	GND SCREW	
4	RGK0212-S	ORNAMENT (VOLUME)	S	31	XTB3+8J	SCREW	
5	RGQ0006-1	ORNAMENT (POWER BUTTON)	K	32	XYN3+C6FZ	SCREW	(GC)
5	RGQ0006-1S	ORNAMENT (POWER BUTTON)	S			PACKING MATERIALS	
6	RMRO136-K	HOLDER	K	P1	RPG0611	CARTON BOX	K
6	RMRO136-S	HOLDER	S	P1	RPG0612	CARTON BOX	S
7	RFKNU610E-K	INDICATOR ASS'Y	K	P2	SPS5185	PAD (AC CORD)	
7	RFKNU610E-S	INDICATOR ASS'Y	S	P3	SPS5255	PAD (FRONT)	
8	SUS800	EARTH SPRING	S	P4	SPS5256-1	PAD (REAR)	
9	SMC6407-2	SHIELD PLATE (VOLUME)		P5	SPP701	PROTECTION COVER	
10	RGU0030	PUSH BUTTON, POWER	K			ACCESSORIES	
10	RGU0030-S	PUSH BUTTON, POWER	S	A1	RQF0773	INSTRUCTIONS MANUAL ASS'Y	(E)
11	RGU0118-K	PUSH BUTTON, SP. SELECT	K	A1	RQF0774	INSTRUCTIONS MANUAL ASS'Y	(EB)
11	RGU0118-S	PUSH BUTTON, SP. SELECT	S	A1	RQF0775	INSTRUCTIONS MANUAL ASS'Y	(EG)
12	RGU0120-K	PUSH BUTTON, TAPE/LOUD/TONE	K	A1	RQF0776	INSTRUCTIONS MANUAL ASS'Y	(GC)
12	RGU0120-S	PUSH BUTTON, TAPE/LOUD/TONE	S	A1	RQF0777	INSTRUCTIONS MANUAL ASS'Y	(GN)
13	RGW0025A-K	KNOB, VOLUME	K	A1-1	RQA0013	WARRANTY CARD	(E, EB, EG)
13	RGW0025A-S	KNOB, VOLUME	S	A1-1	SQX7186	WARRANTY CARD	(GN)
14	RGW0028-2K	KNOB, TONE	K	A1-2	RQCB0169	SERVLICENTOR LIST	
14	RGW0028-S	KNOB, TONE	S	A1-3	RFKSJ610E-K	INSTRUCTIONS MANUAL	(E)
15	RGW0063-1K	KNOB, INPUT SELECTOR	K	A1-3	RQT0671-G	INSTRUCTIONS MANUAL	(EB, GC, GN)
15	RGW0063-S	KNOB, INPUT SELECTOR	S	A1-3	RQT0673-D	INSTRUCTIONS MANUAL	(EG)
16	RKM0036A-K	CABINET	K	A1-4	RQCS0009	CAUTION NOTE for FTZ	(EG)
16	RKM0036A-S	CABINET	S	A1-5	SJP9215	ATTACHMENT AC PLUG	Δ (GC)
17	RFKJU610E-K	BOTTOM BOARD ASS'Y		A1-6	SQX51057	CAUTION NOTE for AC OUTLET	(GC)
17-1	RKA0009-1	FOOT		A2	SFDAC05E03	AC POWER CORD	Δ (E, EG)
17-2	XTB3+6J	SCREW		A2	SJA193	AC POWER CORD	Δ (EB)
18	RGR0092A-A	REAR PANEL	(E)	A2	RJAD004	AC POWER CORD	Δ (GC)
18	RGR0092A-C	REAR PANEL	(EB, GN)	A2	SJA173	AC POWER CORD	Δ (GN)
18	RGR0092A-B	REAR PANEL	(EG)				
18	RGR0092B-A1	REAR PANEL	(GC)				
19	SHE187-2	SPACER					
20	SJS9231A	AC INLET COVER	(E, EB, EG, GC)				
20	SJS9234A	AC INLET COVER	(GN)				
21	SJS9233A	AC OUTLET COVER	(GC)				
22	SNE2129-1	SCREW	K				

EXPLODED VIEW

A

B

C

D

E

F

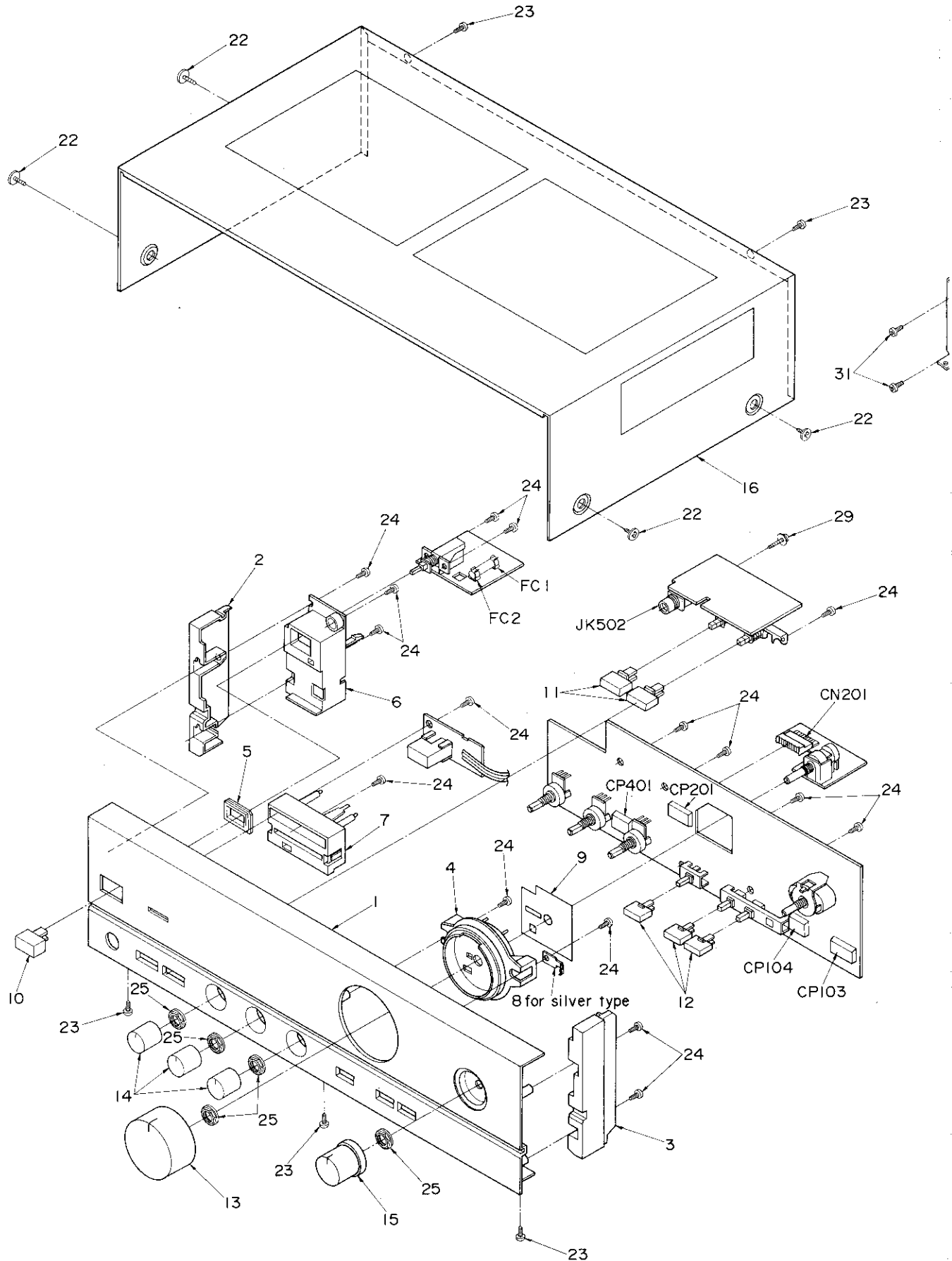

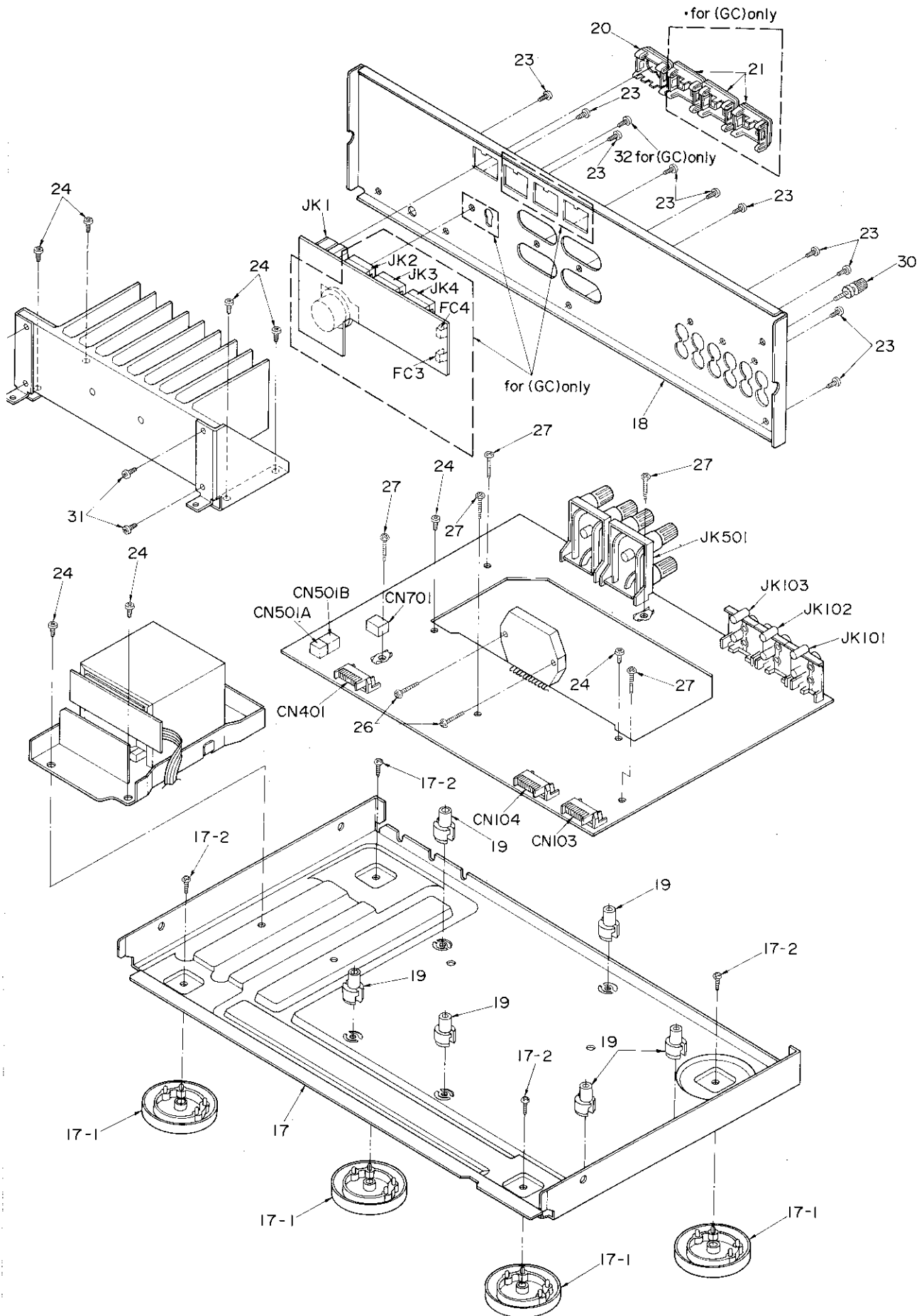

Ref. No.	Part No.	Part Name & Description	Remarks
		INTEGRATED CIRCUIT(S)	
IC101	AN6558F	IC, PHONO EQ AMP.	
IC301	UPC4570C	IC, TONE AMP.	
IC501	SVI3102B	IC, POWER AMP.	
		DIODE(S)	
D553	MA4160MTA	DIODE	
D601	1SR35200TB	DIODE	△
D602	LN018472PH	LED	
D701-704	P300DLF	DIODE	△
D751	MA4160MTA	DIODE	
D752, 753	MA4082MTA	DIODE	
		VARIABLE RESISTOR(S)	
VR201	EWJKXA090B15	V. R. VOLUME CONTROL	
VR202	EWHFDA014G15	V. R. BALANCE CONTROL	
VR301, 302	EWX2XA000C15	V. R. TONE CONTROL	
		THERMISTOR(S)	
TH201, 202	ERTD2ZHL104T	THERMISTOR	
		COIL(S)	
L1	SLQZ650MH49	COIL	△ (EG)
L501, 502	SLQY07G-40	COIL	
		TRANSFORMER(S)	
T1	RTP1M5E005-V	POWER TRANSFORMER	△ (E, EG)
T1	RTP1M5B005-V	POWER TRANSFORMER	△ (EB, GN)
T1	RTP1M5EG06-V	POWER TRANSFORMER	△ (GC)
		FUSE(S)	
F1	XBA2C12TB0	FUSE 250V T1. 25A	△ (E, EG, EB, GN)
F1	XBA2C25TB0	FUSE 250V T2. 5A	△ (GC)
F2	XBA2C12TB0	FUSE 250V T1. 25A	△ (GC)

Ref. No.	Part No.	Part Name & Description	Remarks
		SWITCH(ES)	
S1	ESB8249V	SW, POWER	△
S2	ESE37263	SW, VOLTAGE SELECTOR	△ (GC)
S101	RSR4B003-1	SW, INPUT SELECTOR	
S103	ESB68108	SW, TAPE MONITOR/LOUDNESS	
S301	ESB68107	SW, TONE CONTROL	
S501	RSP2002	SW, SPEAKER SELECTOR	
		JACK(S)	
JK1	SJS9231-1B	AC INLET	△ (E, EB, EG, GC)
JK1	SJS9234B	AC INLET	△ (GN)
JK2-4	SJS9233B	AC OUTLET	△ (GC)
JK101-103	SJF3069N	TERMINAL BOARD	
JK501	RJH4801	SP TERMINAL	
JK502	SJJD19	HEADPHONES	
CN103	RJU003K010M1	SOCKET (10P)	
CN104	RJU003K008M1	SOCKET (8P)	
CN201	RJU003K008M1	SOCKET (8P)	
CN401	RJU003K008M1	SOCKET (8P)	
CN701	RJS1A1704	SOCKET (4P)	
CN501A	RJS1A1704	SOCKET (4P)	
CN501B	RJS1A1703	CONNECTOR (3P)	
CP103	RJT003K010M1	CONNECTOR (10P)	
CP104	RJT003K008M1	CONNECTOR (8P)	
CP201	RJT003K008M1	CONNECTOR (8P)	
CP401	RJT003K008M1	CONNECTOR (8P)	
		FUSE HOLDER	
FC1, 2	SJT390	FUSE HOLDER	△
FC3, 4	SJT388	FUSE HOLDER	△ (GC)

Notes : * Capacity value are in microfarads (uF) unless specified otherwise, P=Pico-farads (pF) F=Farads (F)
 * Resistance values are in ohms, unless specified otherwise, 1K=1,000 (OHM) , 1M=1,000k(OHM)

Ref. No.	Part No.	Values & Remarks	Ref. No.	Part No.	Values & Remarks			
			C105, 106	ECBT1H100J5	50V 10P			
		RESISTORS	C107, 108	ECEA0JK330B	6.3V 33U			
			C109, 110	ECBT1H391KB5	50V 390P			
R101, 102	ERDS2TJ102T	1/4W 1K	C113, 114	ECQMLH223KV3	50V 0.022U			
R105, 106	ERDS2TJ224T	1/4W 220K	C115, 116	ECQMLH682KV3	50V 6800P			
R109, 110	ERDS2TJ391T	1/4W 390	C117, 118	ECEA1HKN010B	50V 1U			
R113, 114	ERDS2TJ563T	1/4W 56K	C119, 120	ECQMLH72KV3	50V 4700P			
R117, 118	ERDS2TJ271T	1/4W 270	C121, 122	ECBT1E103ZF5	25V 0.01U			
R123, 124	ERDS2TJ680T	1/4W 68	C123, 124	ECA1HPXS3R3B	50V 3.3U			
R125, 126	ERDS2TJ184T	1/4W 180K	C201-208	ECBT1H101KB5	50V 100P			
R127, 128	ERDS2TJ123T	1/4W 12K	C213, 214	ECQV1H563JZ3	50V 0.056U			
R129, 130	ERDS2TJ563T	1/4W 56K	C221, 222	ECBT1H181KB5	50V 180P			
R131, 132	ERDS2TJ102T	1/4W 1K	C301, 302	ECEA1HPX3R3B	50V 3.3U			
R201-208	ERDS2TJ102T	1/4W 1K	C303, 304	ECBT1H101KB5	50V 100P			
R211, 212	ERDAS3G563T	1/4W 56K	C305, 306	ECBT1H820KB5	50V 82P			
R213, 214	ERDS2TJ183T	1/4W 18K	C307, 308	ECEA1HPX4R7B	50V 4.7U			
R219, 220	ERDAS3G272T	1/4W 2.7K	C309, 310	ECBT1H390J5	50V 39P			
R221, 222	ERDS2TJ471T	1/4W 470	C311, 312	ECEA1CPX100B	16V 10U			
R225, 226	ERDAS3G563T	1/4W 56K	C313, 314	ECQV1H823JZ3	50V 0.082U			
R301, 302	ERDAS3G561T	1/4W 560	C315, 316	ECQMLH153KV3	50V 0.015U			
R303, 304	ERDS2TJ823T	1/4W 82K	C317, 318	ECQMLH183KV3	50V 0.018U			
R305, 306	ERDS2TJ474T	1/4W 470K	C319, 320	ECQMLH272KV3	50V 2700P			
R307, 308	ERDS2TJ392T	1/4W 3.9K	C321, 322	ECBT1E103ZF5	25V 0.01U			
R309, 310	ERDS2TJ223T	1/4W 22K	C501, 502	ECA1HPXS3R3B	50V 3.3U			
R311, 312	ERDS2TJ102T	1/4W 1K	C503, 504	ECBT1H271KB5	50V 270P			
R313, 314	ERDS2TJ472T	1/4W 4.7K	C505, 506	ECEA1CK220B	16V 22U			
R315, 316	ERDAS3G392T	1/4W 3.9K	C507, 508	ECCR1H100K5	50V 10P			
R317, 318	ERDAS3G223T	1/4W 22K	C509, 510	ECBT1H102KB5	50V 1000P			
R319, 320	ERDS2TJ333T	1/4W 33K	C511, 512	ECKR1H473ZF5	50V 0.047U			
R501, 502	ERDS2TJ392T	1/4W 3.9K	C514	ECEA1HU330B	50V 33U			
R503, 504	ERDS2TJ563T	1/4W 56K	C515	ECEA1HN100SB	50V 10U			
R505, 506	ERDS2TJ222T	1/4W 2.2K	C518, 519	ECKR1H473ZF5	50V 0.047U			
R507, 508	ERDS2TJ563T	1/4W 56K	C523, 524	ECBT1H102KB5	50V 1000P			
R509, 510	ERDFS2VJ470T	1/4W 47	C601	ECEA1CU470B	16V 47U			
R511, 512	ERD25FVJ100T	1/4W 10 Δ	C705, 706	ECETS42V472U	42V 4700U			
R514	ERDS1FVJ272T	1/2W 2.7K Δ	C711	ECKR2H103ZU	500V 0.01U			
R517, 518	ERDS2TJ561T	1/4W 560	C712	ECKR1H473ZF5	50V 0.047U			
R520	ERDS2TJ124T	1/4W 120K	C731-734	ECQMLH473KV3	50V 0.047U			
R523, 524	ERDS1FVJ331T	1/2W 330 Δ	C751, 752	ECA1EPXS470B	25V 47U			
R528	ERDS2TJ684T	1/4W 680K						
R601	ERDS1FVJ120T	1/2W 12 Δ						
R602	ERDS2TJ271T	1/4W 270						
R751, 752	ERDS1FVJ561T	1/2W 560 Δ						
R753-755	ERDS1FVJ271T	1/2W 270 Δ						
		CAPACITORS						
C1	ECKWKC103PF2	400V 0.01U Δ						
C103, 104	ECBT1H181KB5	50V 180P						