

ONKYO® SERVICE MANUAL

AV RECEIVER MODEL HT-R548(B)/(S)

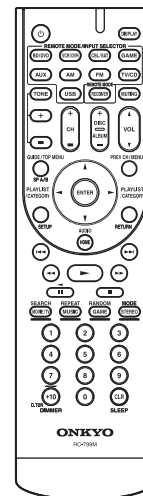
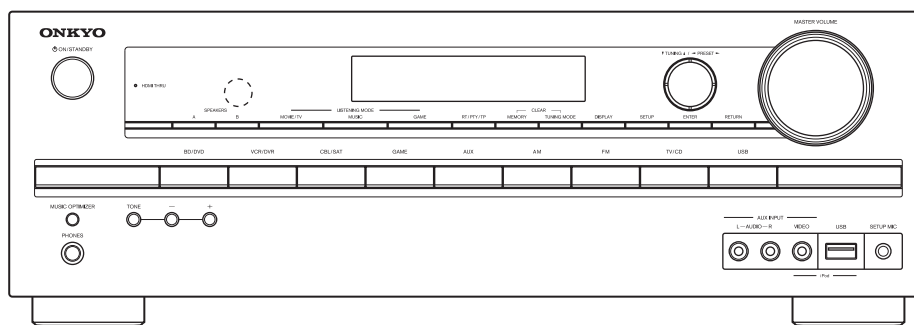

RC-799M

HT-R548 for HT-S5405 Black and Silver models

B MPP, S MPP	230V AC, 50Hz
B MMQ	220-240V AC, 50/60Hz

SAFETY-RELATED COMPONENT WARNING!!

COMPONENTS IDENTIFIED BY MARK  ON THE SCHEMATIC DIAGRAM AND IN THE PARTS LIST ARE CRITICAL FOR RISK OF FIRE AND ELECTRIC SHOCK. REPLACE THESE COMPONENTS WITH ONKYO PARTS WHOSE PART NUMBERS APPEAR AS SHOWN IN THIS MANUAL.

MAKE LEAKAGE-CURRENT OR RESISTANCE MEASUREMENTS TO DETERMINE THAT EXPOSED PARTS ARE ACCEPTABLY INSULATED FROM THE SUPPLY CIRCUIT BEFORE RETURNING THE APPLIANCE TO THE CUSTOMER.

ONKYO SOUND & VISION CORPORATION
Service Department

EXPLODED VIEWS-1

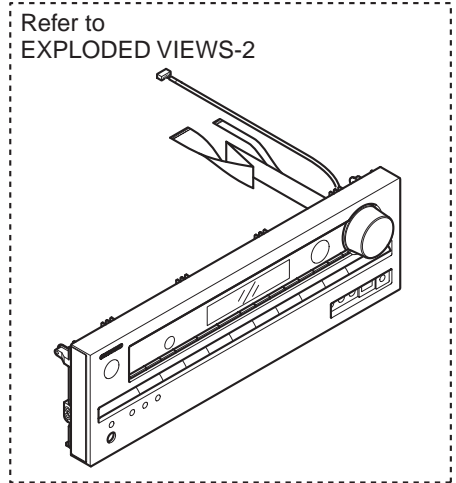
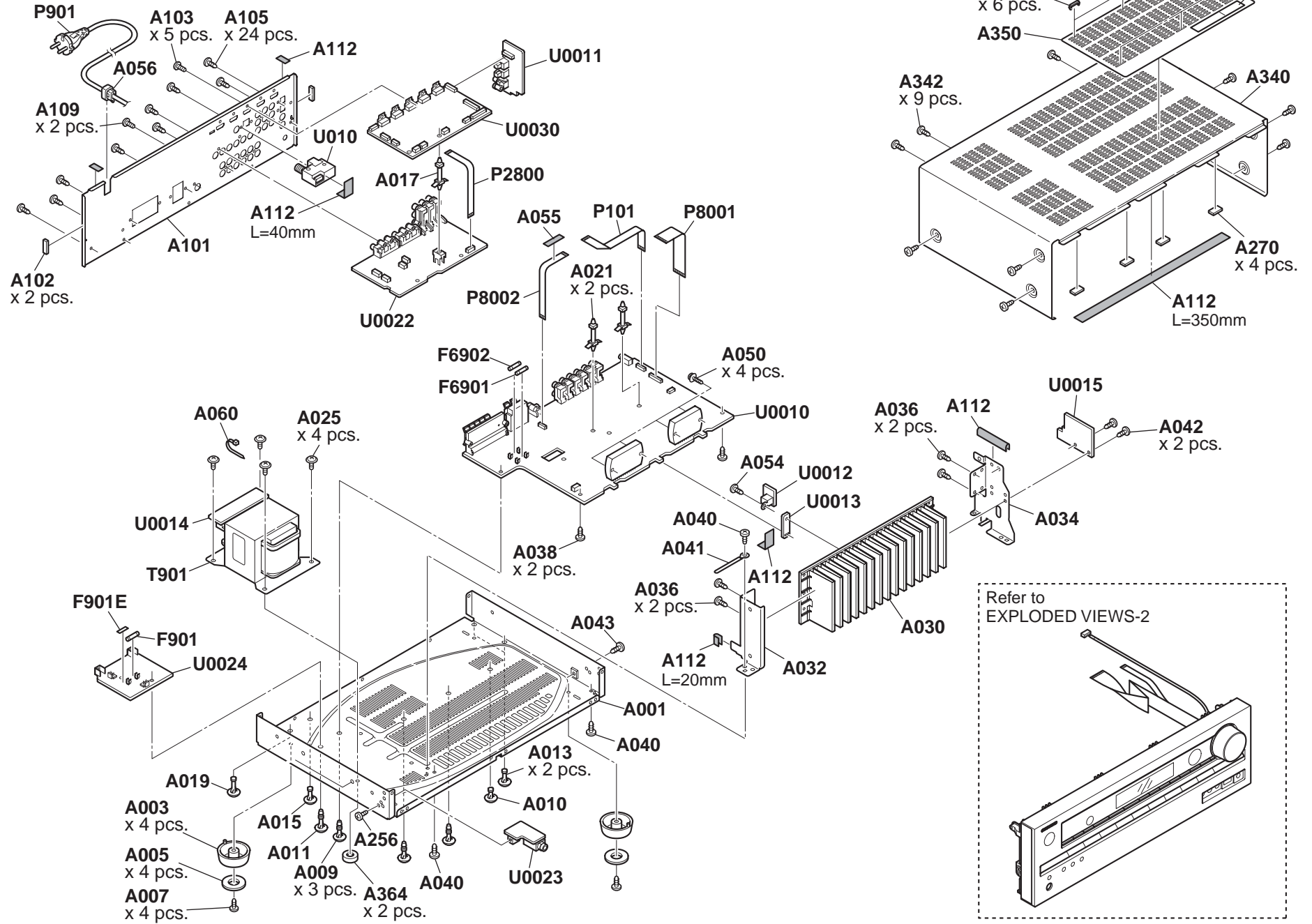

EXPLODED VIEWS-2

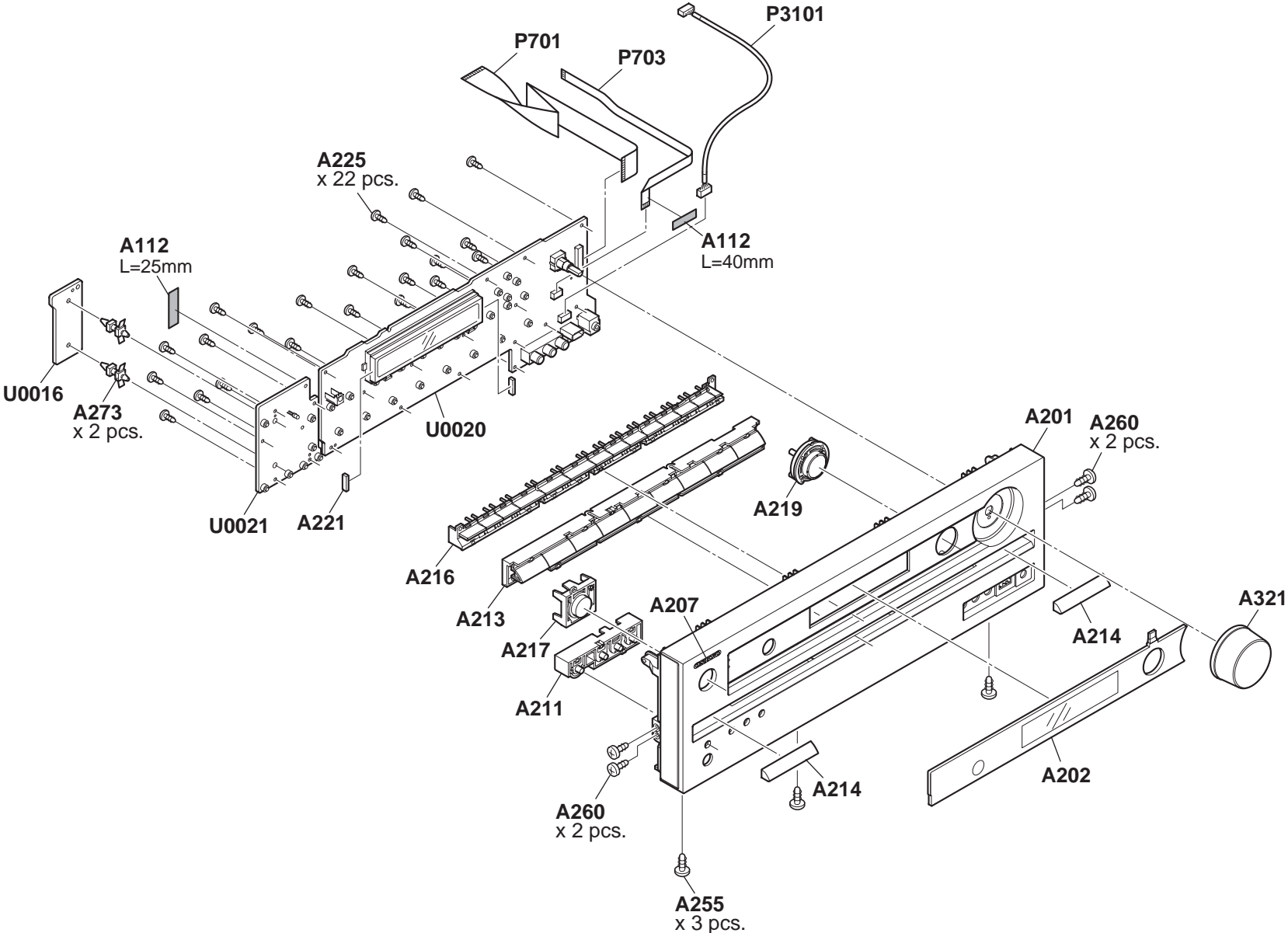

SCHEMATIC DIAGRAM/ BLOCK DIAGRAM-01 TX-SR309/HT-R390/HT-R548/HT-RC330 BLOCK DIAGRAM-1 AUDIO Section (PART-1)

1
2
3
4
5

BLOCK DIAGRAM
AUDIO SECTION PART-1

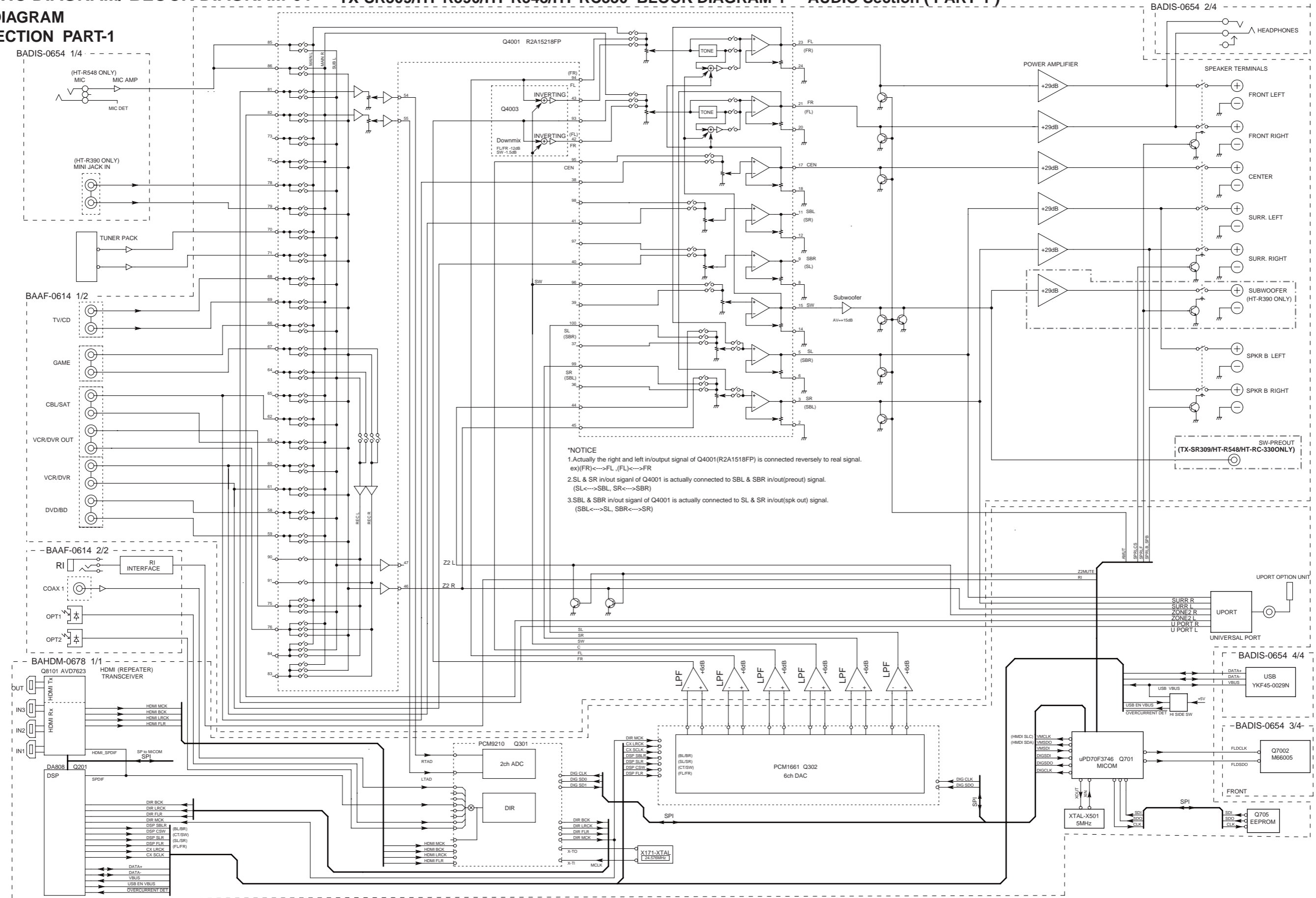

BADIS-0654 2/4

HEADPHONES

SPEAKER TERMINALS

FRONT LEFT

FRONT RIGHT

CENTER

SURR. LEFT

SURR. RIGHT

SUBWOOFER (HT-R390 ONLY)

SPKR B LEFT

SPKR B RIGHT

UPORT OPTION UNIT

UNIVERSAL PORT

BADIS-0654 4/4

BADIS-0654 3/4

FRONT

Q7002 M66005

Q705 EEPROM

SCHEMATIC DIAGRAM/ BLOCK DIAGRAM-1

BLOCK DIAGRAM
AUDIO SECTION PART-1

TX-NR509/TX-NA509/HT-R590 BLOCK DIAGRAM AUDIO Section (PART-1)

1
2
3
4
5

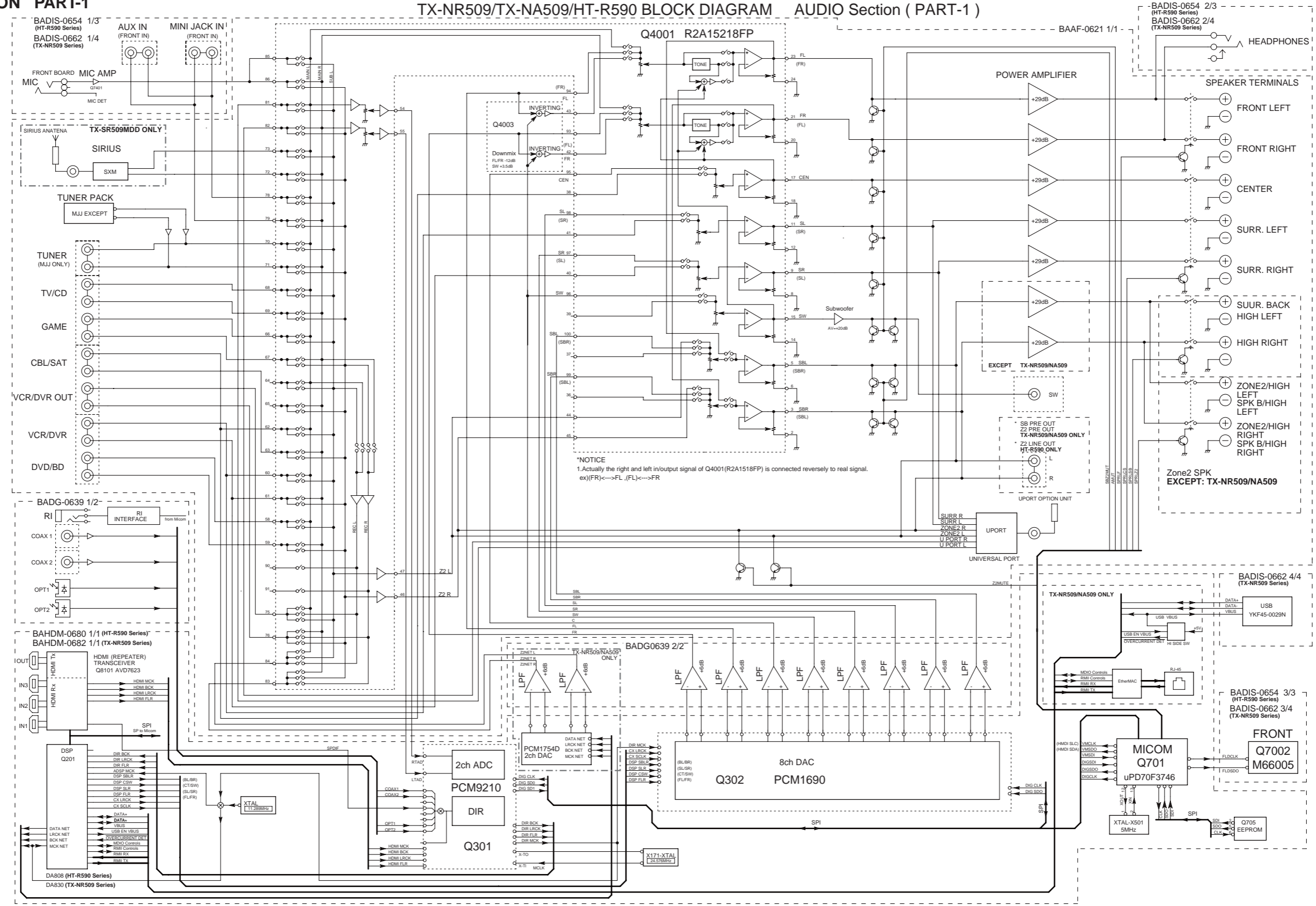

*NOTICE
1. Actually the right and left in/output signal of Q4001(R2A1518FP) is connected reversely to real signal.
ex)(FR)←→(FL) ,(L)←→(R)

EXCEPT TX-NR509/NA509

Zone2 SPK
EXCEPT: TX-NR509/NA509

BADIS-0662 4/4
(TX-NR509 Series)

BADIS-0654 3/3
(HT-R590 Series)
BADIS-0662 3/4
(TX-NR509 Series)

FRONT
Q7002
M66005

SCHEMATIC DIAGRAM/ BLOCK DIAGRAM-1 BLOCK DIAGRA AUDIO SECTION PART-1

TX-NR609/TX-NA609/HT-RC360/DTR-30.3/DTR-20.3 BLOCK DIAGRAM AUDIO Section (PART-1)

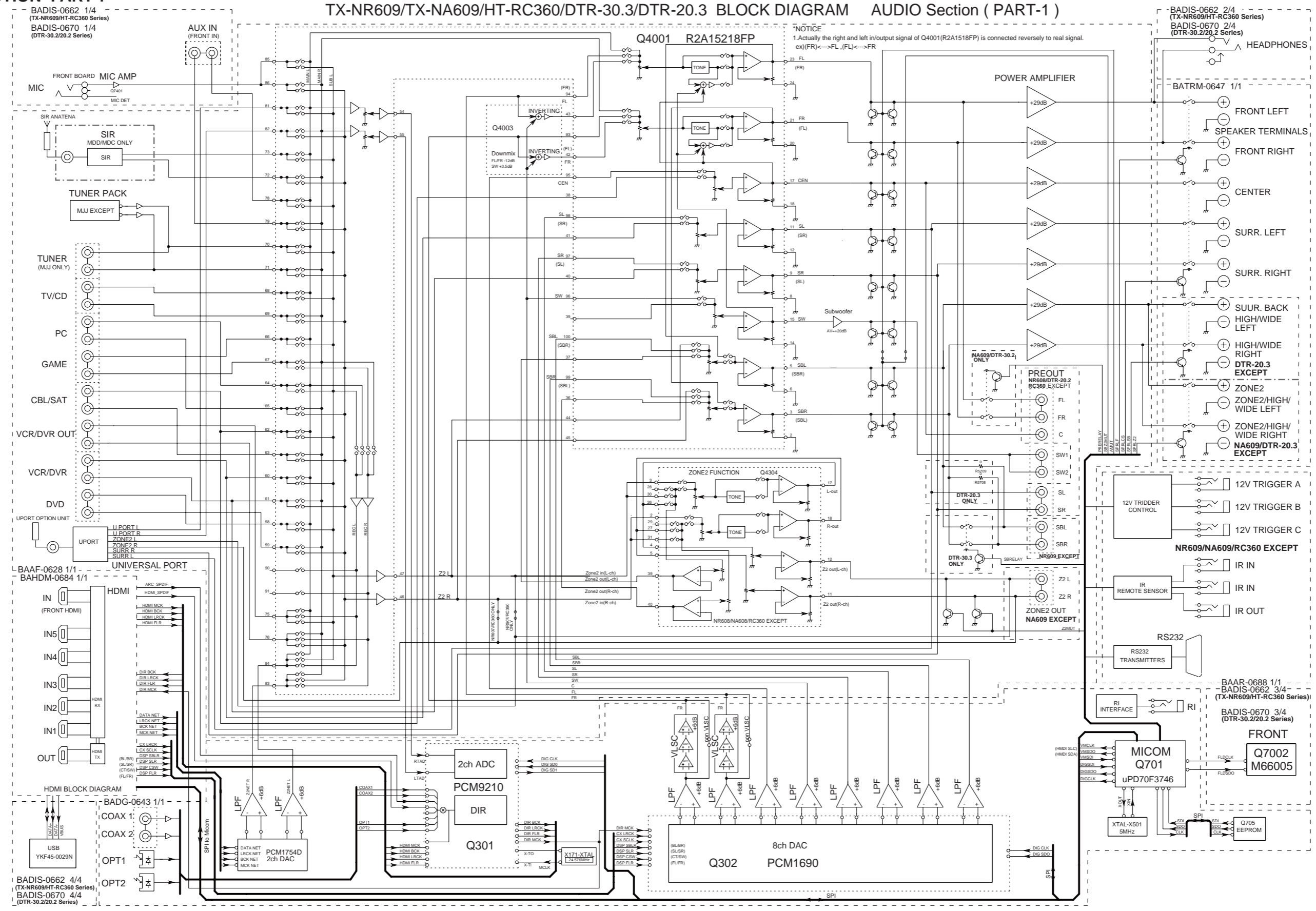

SCHEMATIC DIAGRAM/ BLOCK DIAGRAM-2

BLOCK DIAGRAM VIDEO SECTION PART-2

Model No. TX-SR309/509/609/TX-SA509/609/HT-R290/390/548/590/690/990/HT-RC330/360/DTR-20.3/30.3

SCHEMATIC DIAGRAM (PART-2)

BLOCK DIAGRAM(VIDEO)

1

2

3

4

5

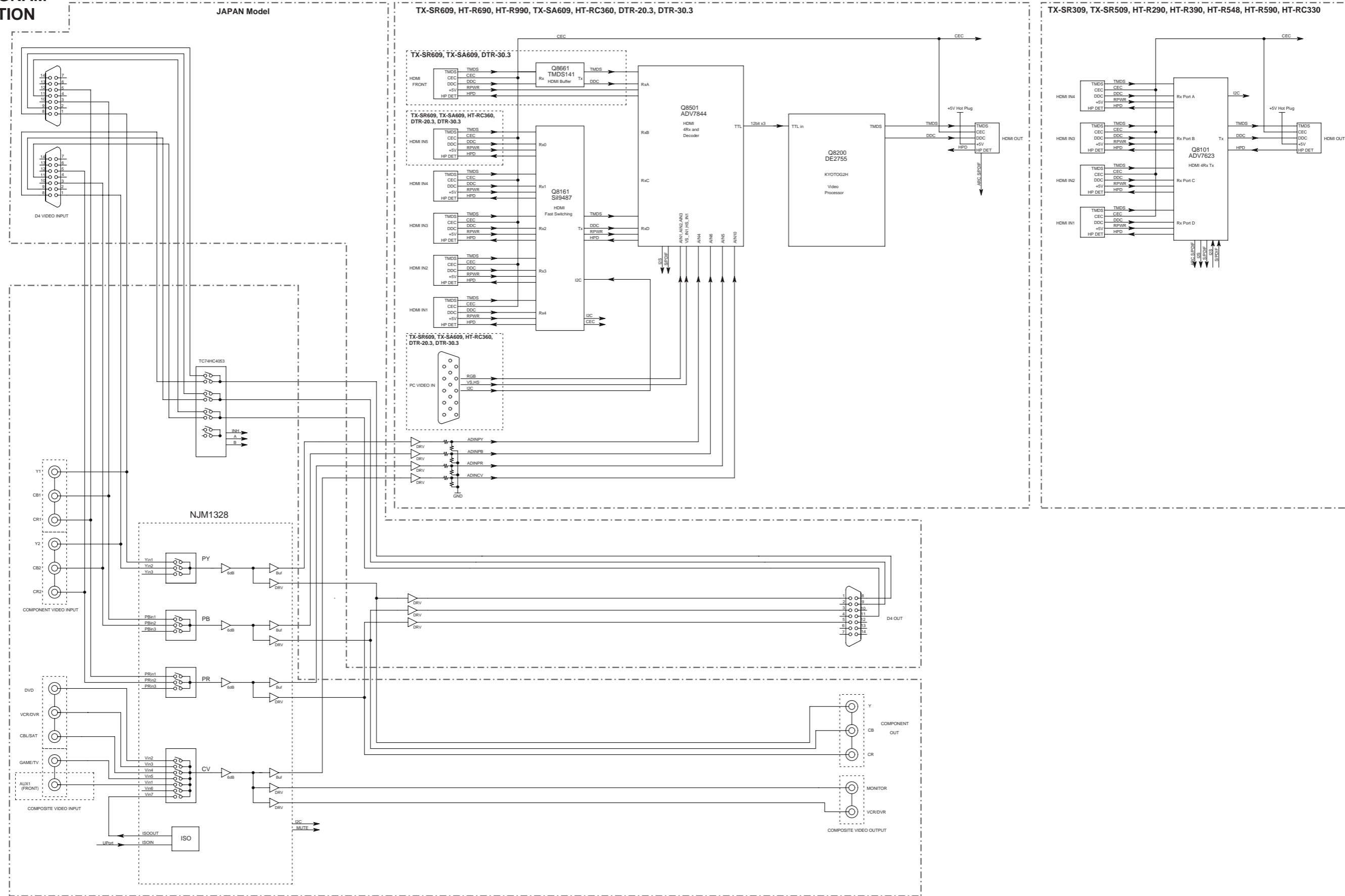

SCHEMATIC DIAGRAM/ BLOCK DIAGRAM-3
AUDIO INPUT SECTION PART-3

MODEL NO. TX-SR309/HT-R390/HT-R548/HT-RC330/HT-R290 SCHEMATIC DIAGRAM (PART-3) AUDIO INPUT

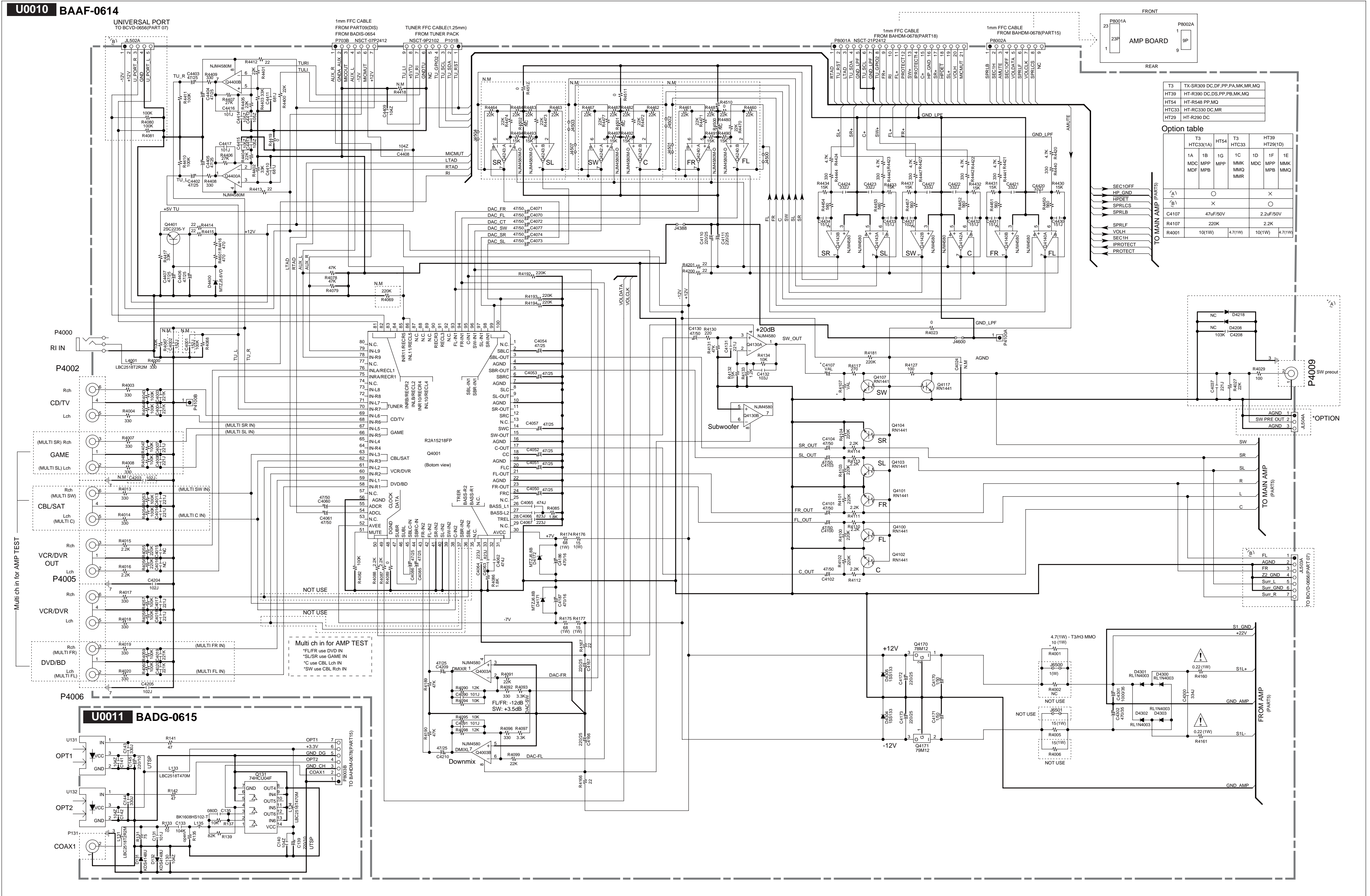

SCHEMATIC DIAGRAM/ BLOCK DIAGRAM-3
AUDIO INPUT SECTION PART-3

MODEL NO. TX-NR509/ TX-NR579/ TX-NA579/ HT-R590/ HT-R690/ HT-R990 SCHEMATIC DIAGRAM (PART-3)

AUDIO INPUT

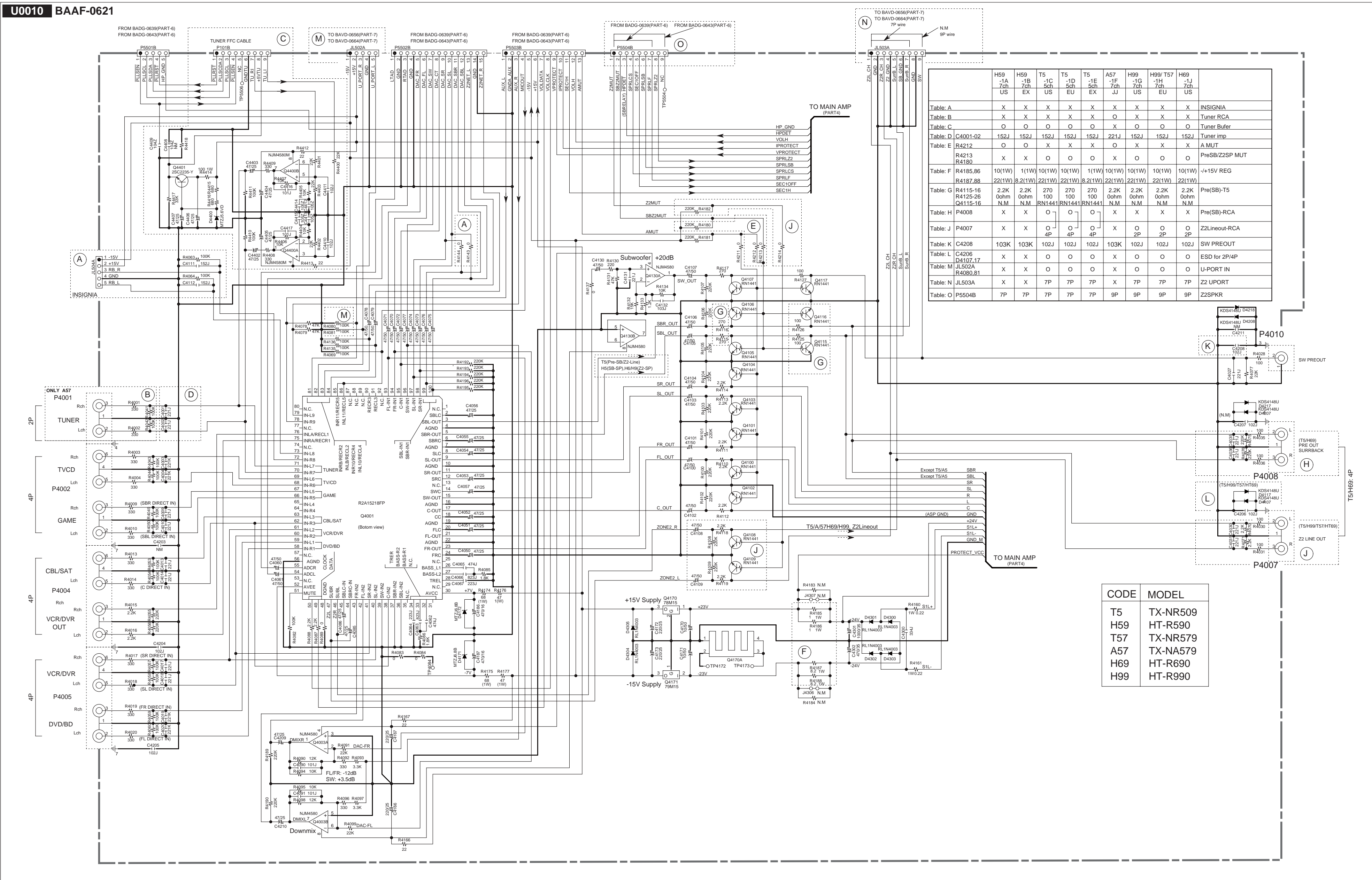

	H59 -1A 7ch US	H58 -1B 7ch EX	T5 -1C 5ch US	T5 -1D 5ch EU	T5 -1E 5ch EX	A57 -1F 7ch JJ	H99 -1G 7ch US	H99/T57 -1H 7ch EU	H69 -1J 7ch US	
Table A	X	X	X	X	X	X	X	X	X	INSIGNIA
Table B	X	X	X	X	X	X	X	X	X	Tuner RCA
Table C	O	O	O	O	O	O	O	O	O	Tuner Buffer
Table D	C4001-02	152J	152J	152J	152J	221J	152J	152J	152J	Tuner imp
Table E	R4212	O	O	X	X	X	O	X	X	A MUT
	R4213	X	X	O	O	O	X	O	O	PreSB/Z2SP MUT
	R4180	O	O	O	O	O	O	O	O	
Table F	R4185,86	10(1W)	1(1W)	10(1W)	10(1W)	1(1W)	10(1W)	10(1W)	10(1W)	-1+15V REG
	R4187,88	22(1W)	8.2(1W)	22(1W)	22(1W)	8.2(1W)	22(1W)	22(1W)	22(1W)	
Table G	R4115-16	2.2K	2.2K	270	270	270	2.2K	2.2K	2.2K	Pre(SB)-T5
	R4125-26	0ohm	0ohm	100	100	100	0ohm	0ohm	0ohm	
	Q4115-16	N.M	N.M	RN1441	RN1441	RN1441	N.M	N.M	N.M	
Table H	P4008	X	X	O	O	O	X	X	X	Pre(SB)-RCA
Table J	P4007	X	X	O	O	O	X	O	O	Z2Lineout-RCA
Table K	C4208	103K	103K	102J	102J	102J	103K	102J	102J	SW PREOUT
Table L	C4206	X	X	O	O	O	X	O	O	ESD for 2P4P
	D4107,17	X	X	O	O	O	X	O	O	
Table M	JL502A	X	X	O	O	O	X	O	O	U-PORT IN
	R4080,81	X	X	O	O	O	X	O	O	
Table N	JL503A	X	X	7P	7P	7P	X	7P	7P	Z2 UPORT
Table O	P5504B	7P	7P	7P	7P	7P	9P	9P	9P	Z2SPKR

CODE	MODEL
T5	TX-NR509
H59	HT-R590
T57	TX-NR579
A57	TX-NA579
H69	HT-R690
H99	HT-R990

SCHEMATIC DIAGRAM / BLOCK DIAGRAM-3

AUDIO INPUT SECTION PART-3

MODEL NO. TX-NR609/NA609/HT-RC360/DTR-20.3/DTR-30.3 SCHEMATIC DIAGRAM (PART-3) AUDIO INPUT

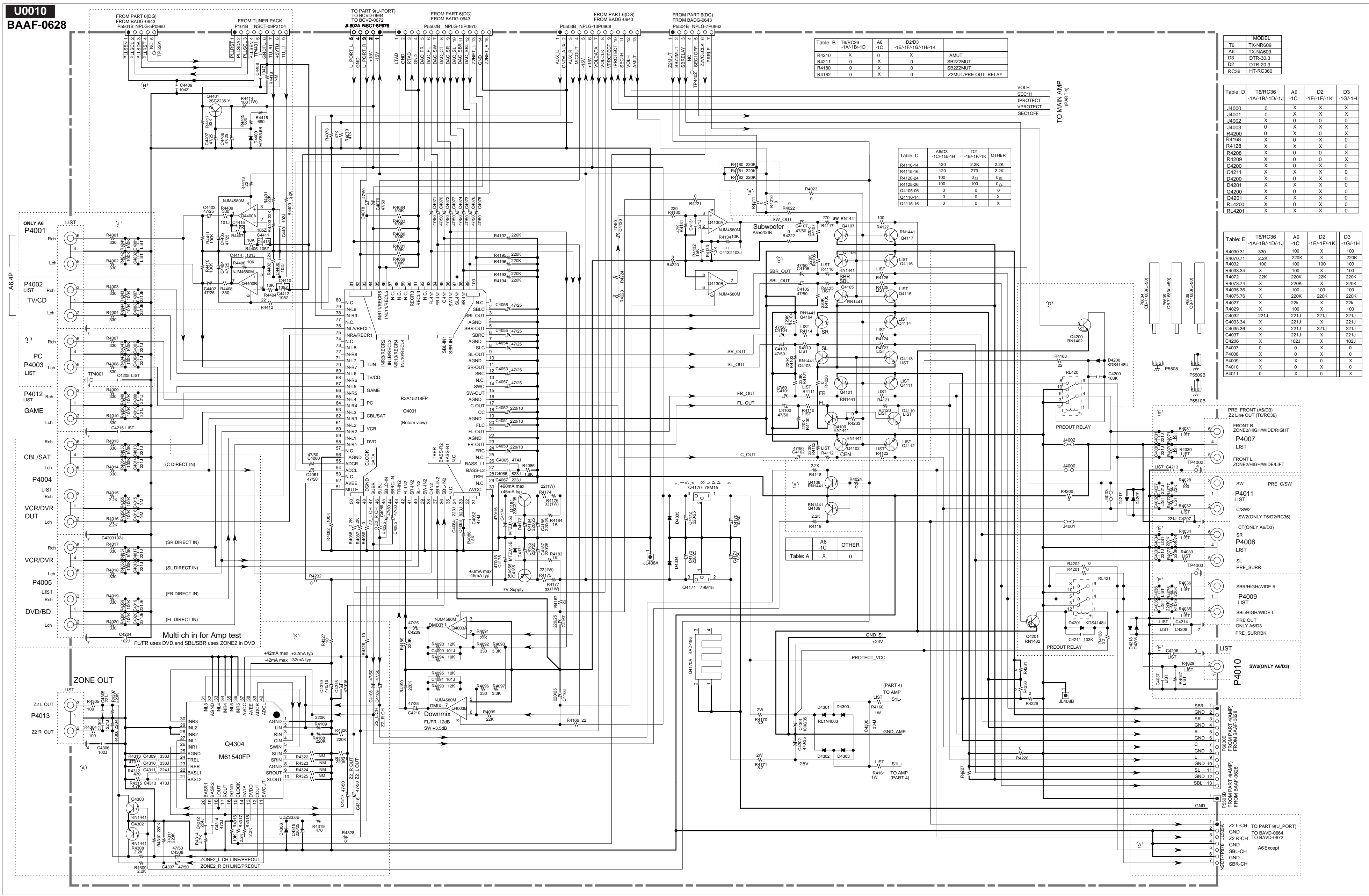

1
2
3
4
5
6
7
8

SCHEMATIC DIAGRAM/ BLOCK DIAGRAM-4

AMP SECTION PART-4

1 MODEL NO. TX-NR509/ TX-NR579/ TX-NA579/ HT-R590/ HT-R690/ HT-R990 SCHEMATIC DIAGRAM (Part-4) AMP SECTION

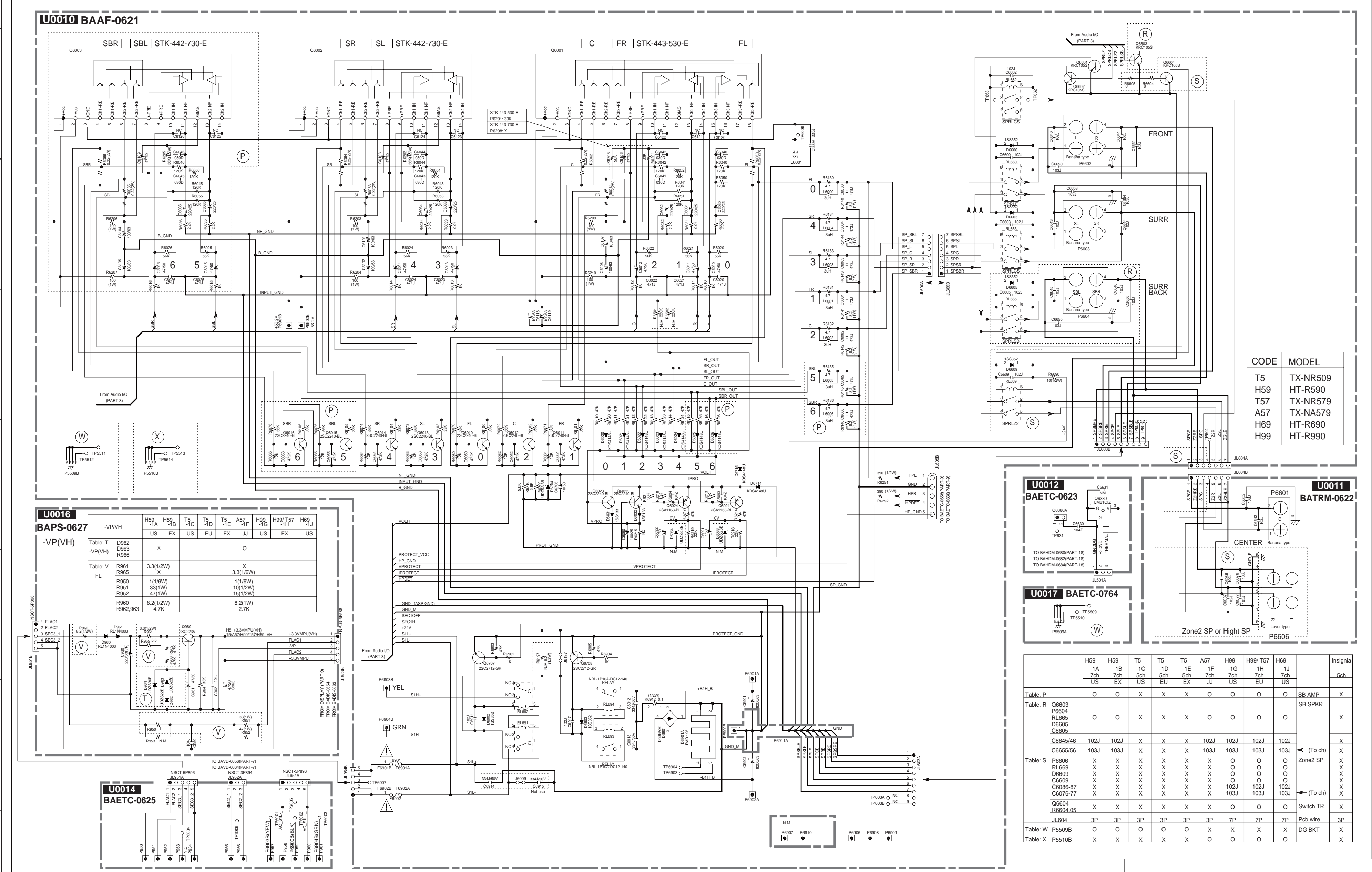

CODE	MODEL
T5	TX-NR509
H59	HT-R590
T57	TX-NR579
A57	TX-NA579
H69	HT-R690
H99	HT-R990

U0016 BAPS-0627 -VP(VH)

-VP/VH	H59 -1A	H59 -1B	T5 -1C	T5 -1D	T5 -1E	A57 -1F	H99 -1G	H99/T57 -1H	H69 -1J
Table T	D962	X							
-VP(VH)	D963								
	R966								
Table V	R961	3.3(1/2W)				X			
FL	R965						3.3(1/8W)		
	R950	1(1/6W)							
	R951	33(1W)					10(1/2W)		
	R952	47(1W)					15(1/2W)		
	R960	8.2(1/2W)					8.2(1W)		
	R962, R963	4.7K					2.7K		

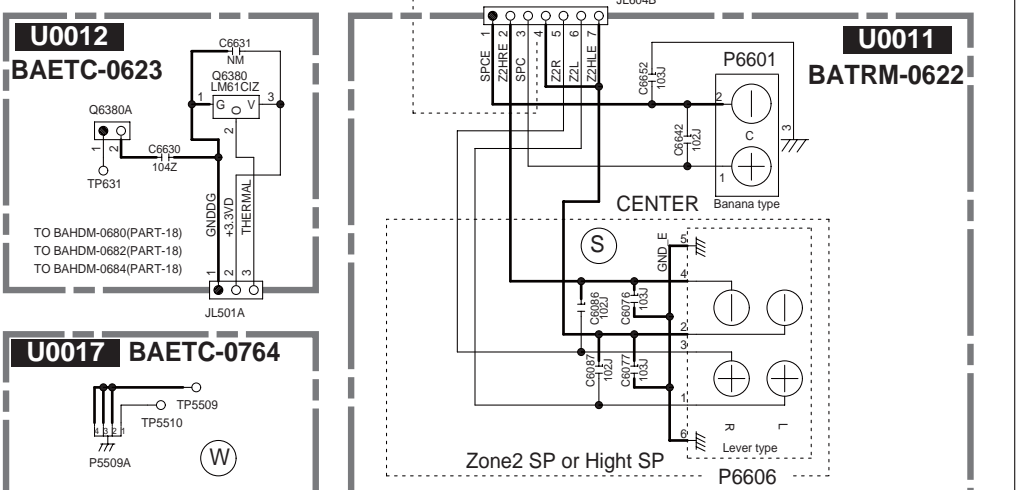

	H59 -1A	H59 -1B	T5 -1C	T5 -1D	T5 -1E	A57 -1F	H99 -1G	H99/T57 -1H	H69 -1J	Insignia
Table P	O	O	X	X	X	O	O	O	O	SB AMP
Table R	O	O	X	X	X	O	O	O	O	SB SPKR
	C6645/46	102J	X	X	X	X	102J	102J	102J	X
	C6655/56	103J	X	X	X	X	103J	103J	103J	X
Table S	P6606	X	X	X	X	X	O	O	O	Zone2 SP
	RL669	X	X	X	X	X	O	O	O	X
	D6609	X	X	X	X	X	O	O	O	X
	C6096-97	X	X	X	X	X	X	102J	102J	X
	C6076-77	X	X	X	X	X	X	103J	103J	X
	R6604	X	X	X	X	X	O	O	O	Switch TR
	JL604	3P	3P	3P	3P	3P	7P	7P	7P	Pcb wire
Table W	P5509B	O	O	O	O	O	X	X	X	DG BKT
Table X	P5510B	X	X	X	X	X	O	O	O	X

SCHEMATIC DIAGRAM/ BLOCK DIAGRAM-4

AMP. SECTION PART-4

MODEL NO. TX-NR609/NA609/HT-RC360/DTR-20.3/DTR-30.3 SCHEMATIC DIAGRAM (PART-4) AMP SECTION

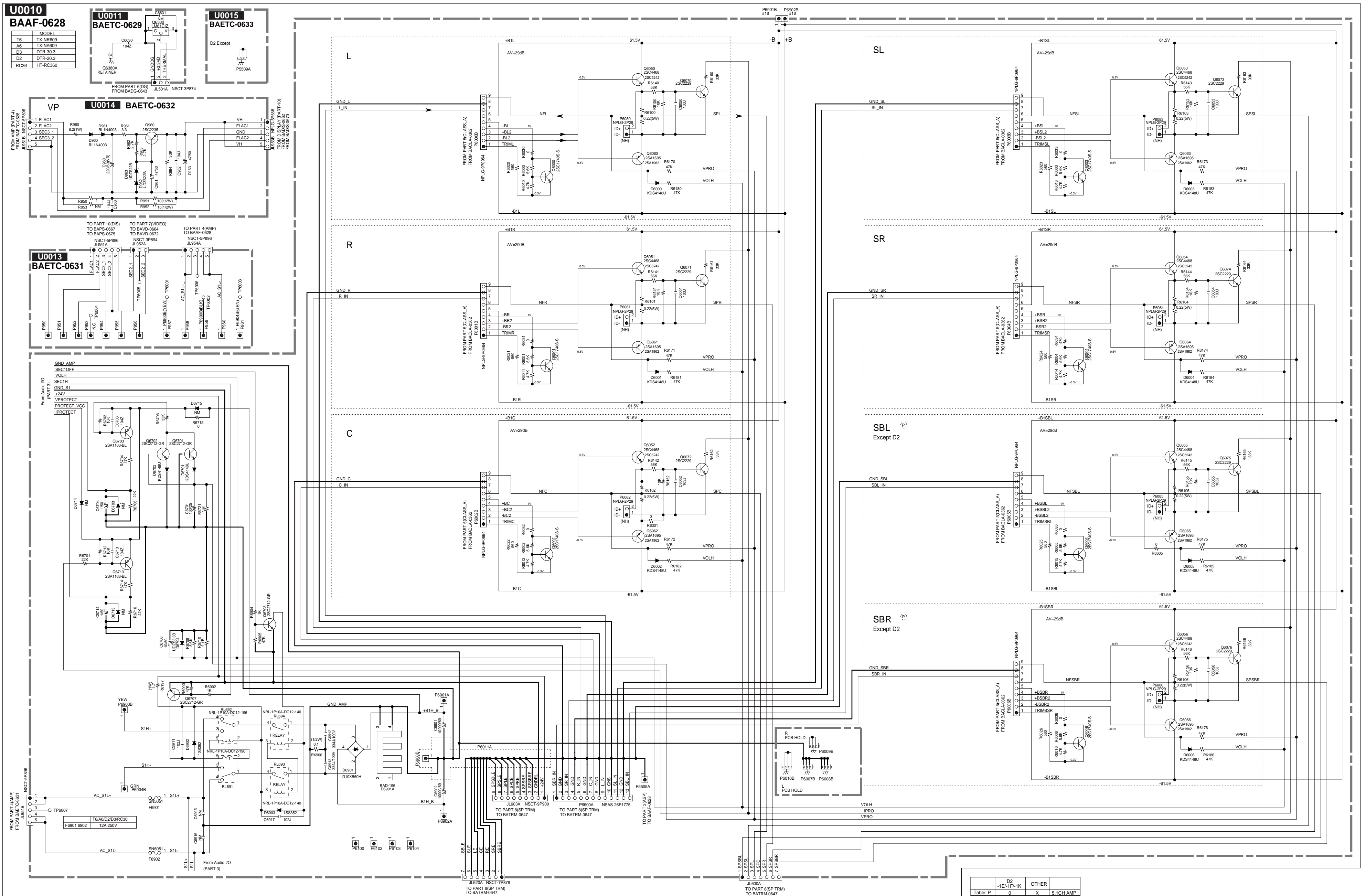

Table P	D2	OTHER
-1E/-1F/-1K	X	5.1CH AMP
0		

SCHEMATIC DIAGRAM/ BLOCK DIAGRAM-4

AMP. SECTION PART-4

Model No. TX-SR309/HT-R390/HT-R548/HT-RC330/HT-R290
SCHEMATIC DIAGRAM (Part-4) AMP SECTION

U0010
BAAF-0614

Notes
THE COMPONENTS IDENTIFIED BY MARK ARE CRITICAL FOR SAFETY. REPLACE ONLY WITH PART NUMBER SPECIFIED.
VOLTAGE(MEASURED WITH VOLTMETER) IS DC VOLTAGE (NO INPUT SIGNAL IN HT-R340MPP)
ELECTROLYTIC CAPACITORS: ARE IN uF/WV.
EX: 100uF 35V 330 330F 331 330F 333 0.033uF
CIRCUIT IS SUBJECT TO CHANGE FOR IMPROVEMENT. ALL CAPACITORS ARE IN pF/50WV UNLESS OTHERWISE NOTED.

CAUTION
AFR (ASSEMBLY LINE PROTECTION PERMANENTLY COPIES THE RESISTOR TYPE AND RATING INDICATED)
ATTENTION
THIS SYMBOL LOCATED NEAR THE FUSE INDICATES PERMANENTLY COPIES THE FUSE TYPE AND RATING REFER TO THE MARKING ADJACENT TO THE SYMBOL.
IF SYMBOL INDICATE QUE IS FUSIBLE (FUSE) BUT NOT CLEARLY FUSE, THE PROTECTION PERMANENTLY COPIES THE FUSE TYPE AND RATING REFER TO THE MARKING ADJACENT TO THE SYMBOL.

*Q6001/Q6002 Terminal Voltage

PIN NO.	Q6001/Q6002
1	+49V
2	-49V
4,5,6,7	0V
8	-46V
9	+46V
12	-45V
10,11,13,14	-0.16V
15,16	-0.16V

(1uA for T3/Q6002)

T3 TX-SR309 DC.DF.PP.PA.MK.MR.MG
HT39 HT-R390 DC.DS.PP.PB.MK.MG
HT54 HT-R548 PP.MG
HTC33 HT-RC330 DC.MR
HT29 HT-R290 DC

MODEL	Power Trans
T3/HTC33 1A, HT29/HT39 1D	NPT-1603D
T3 1B/HT39 1F/HT54 1G	NPT-1603P
T3/HTC33 1C, HT39 1E/HT54 1H	NPT-1603M

Destination table

	T3/HT54/HTC33	HT39/HT29
-1A	MDC	MDD
-1B/-1G	MPP	MPP
-1C/-1H	MMK	MMQ
-1D	MPA	MPB
-1E	MMR	MMK
MDF	MDF	MDF
MDC	MDC	MDC
MPP	MPP	MPP
MMK	MMK	MMK
MPA	MPA	MPA
MMR	MMR	MMR

Q6002 STK-442-730-E STK-443-530-E
J6477
P6001 NTM-10PDM NTM-12PDM
C6901 8200u 8200u 8200u 8200u
C6902 56V 63V 56V 63V

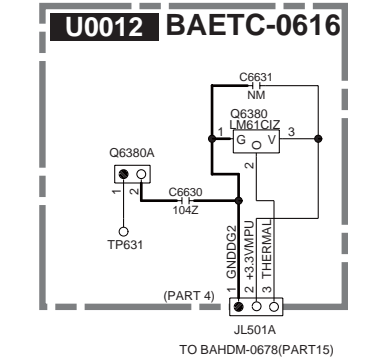
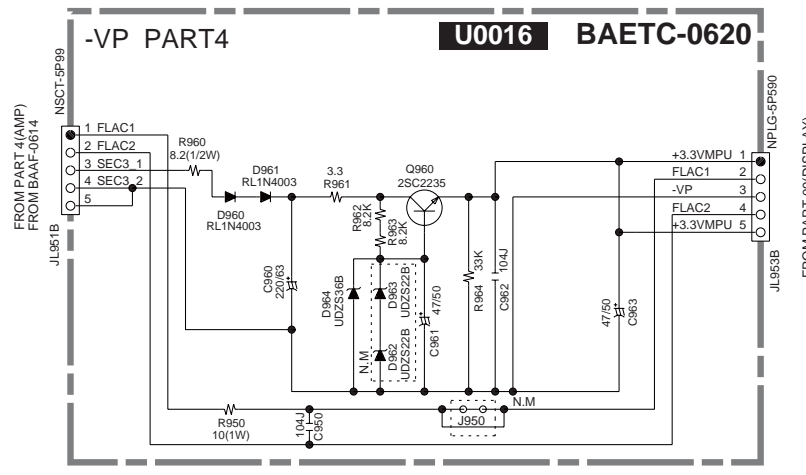
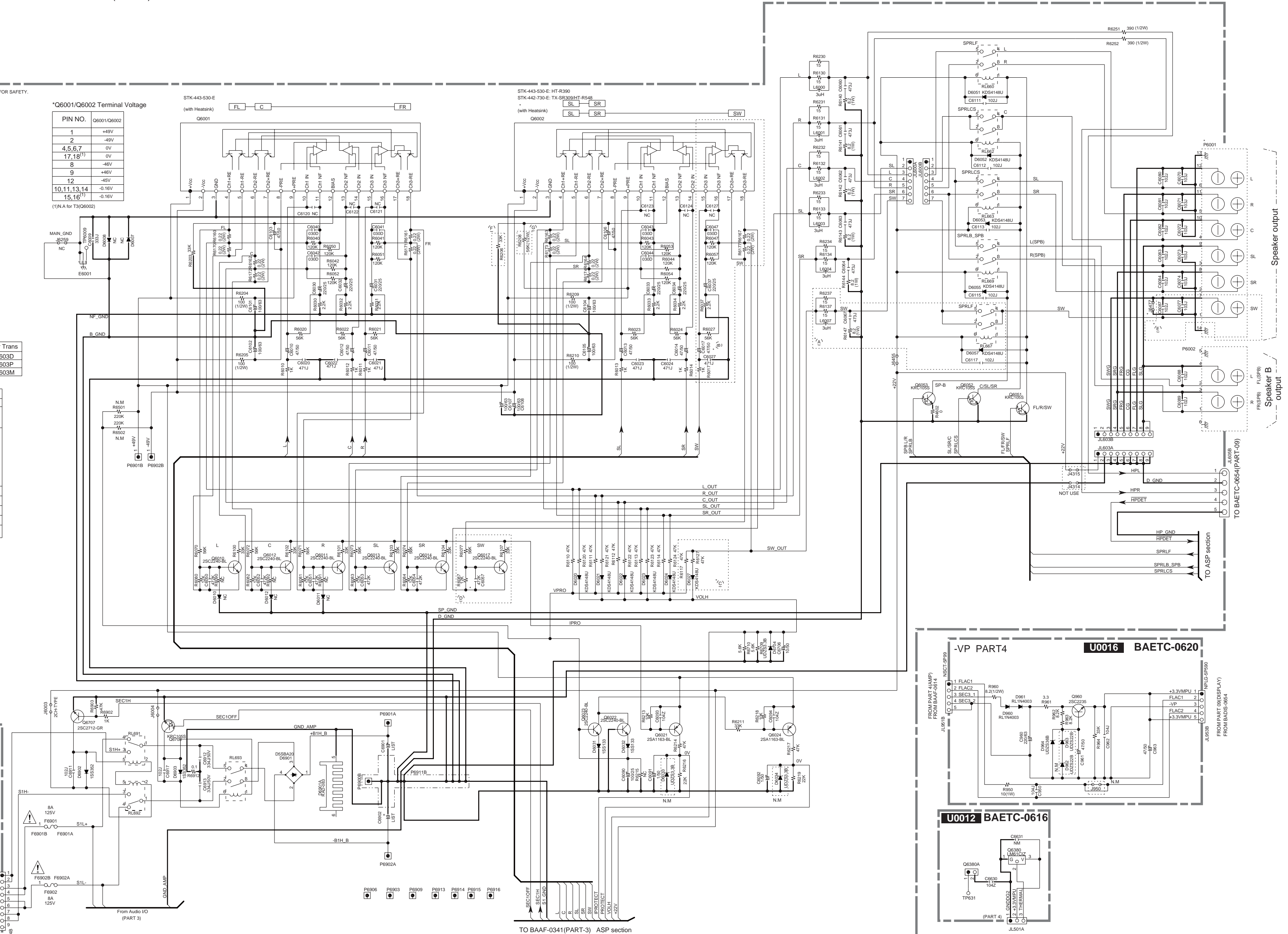
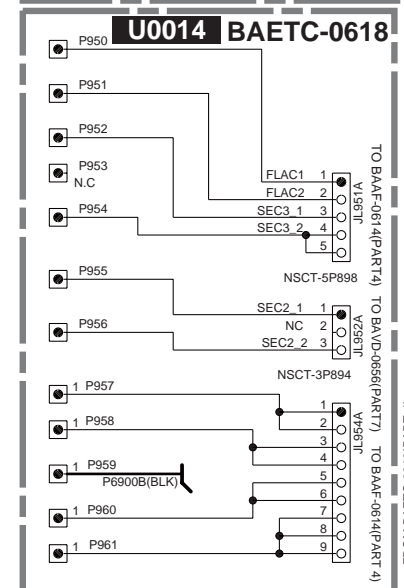

Speaker output
Speaker B output

TO BAAF-0341(PART-3) ASP section

TO BAETC-0654(PART-09)

TO BAHM-0678(PART15)

A B C D E F G H
SCHEMATIC DIAGRAM/ BLOCK DIAGRAM-5

AMP. (Input stage) SECTION
PART-5

Model No. TX-SR609, TX-SA609, HT-RC360, DTR-20.3, DTR-30.3 SCHEMATIC DIAGRAM (Part-5) AMP(input stage) SECTION

1

2

3

4

5

U0060
BACLA-0362

CODE	MODEL
T6	TX-SR609
A6	TX-SA609
H26	HT-RC360
D2	DTR-20.3
D3	DTR-30.3

IDLING CURRENT ADJUSTMENT

1. Wait for 4 - 6 minutes after power on. (Heat running)
2. Re-adjust the trimming resistors according to the following values.

Adjustment point	Measured value	Re-adjustment value
R6040 ~ R6046	In case below 6 mV	→ 6 mV
	In case 6 - 8 mV	→ 8 mV
	In case 8 - 12 mV	→ No re-adjustment
	In case over 12mV	→ 12 mV

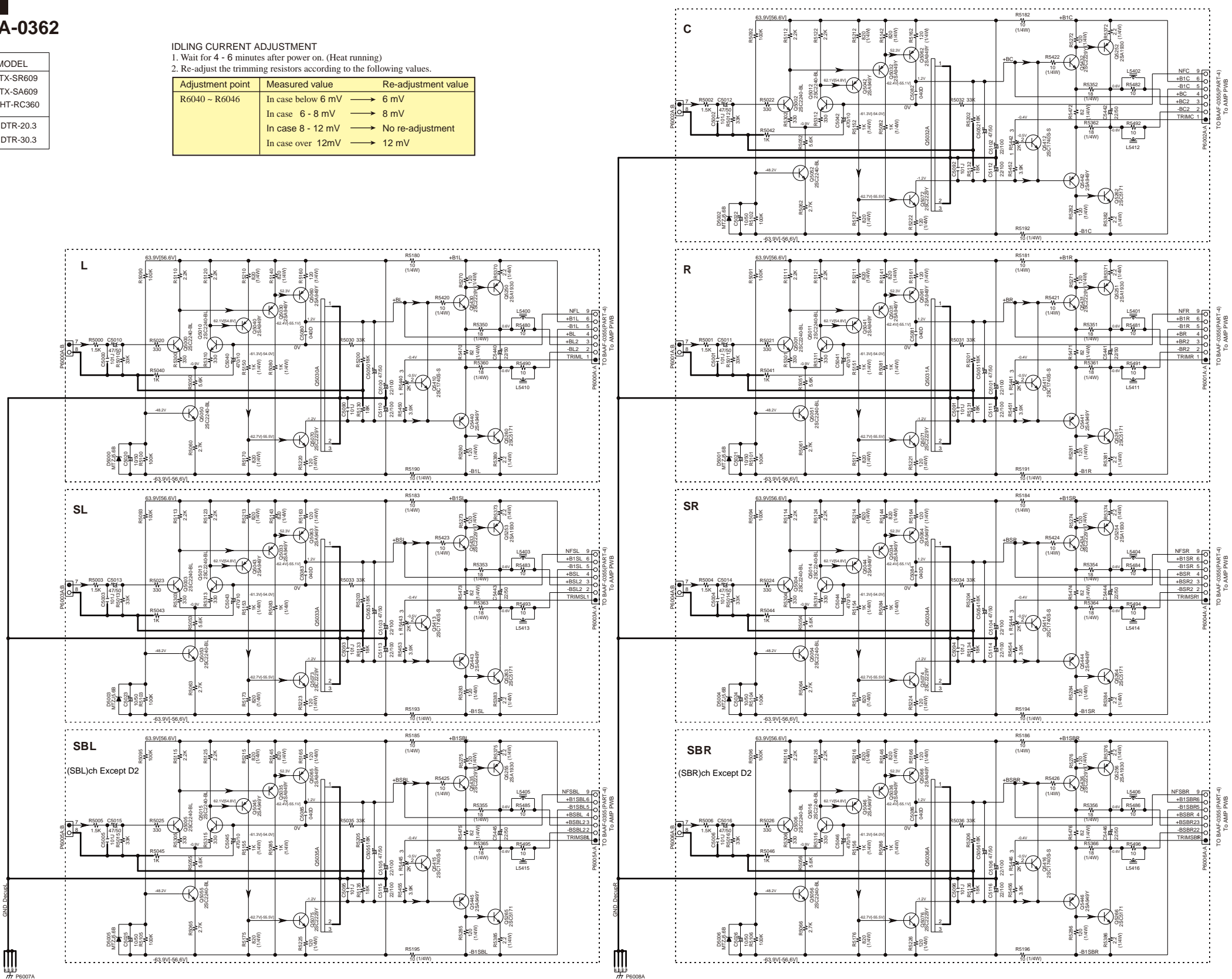

BACLA-0362

SCHEMATIC DIAGRAM/ BLOCK DIAGRAM-6 DG_A SECTION PART-6

HT-R590/TX-NR509 Schematic Diagram (Part-6) DG_A Section

1

2

3

4

5

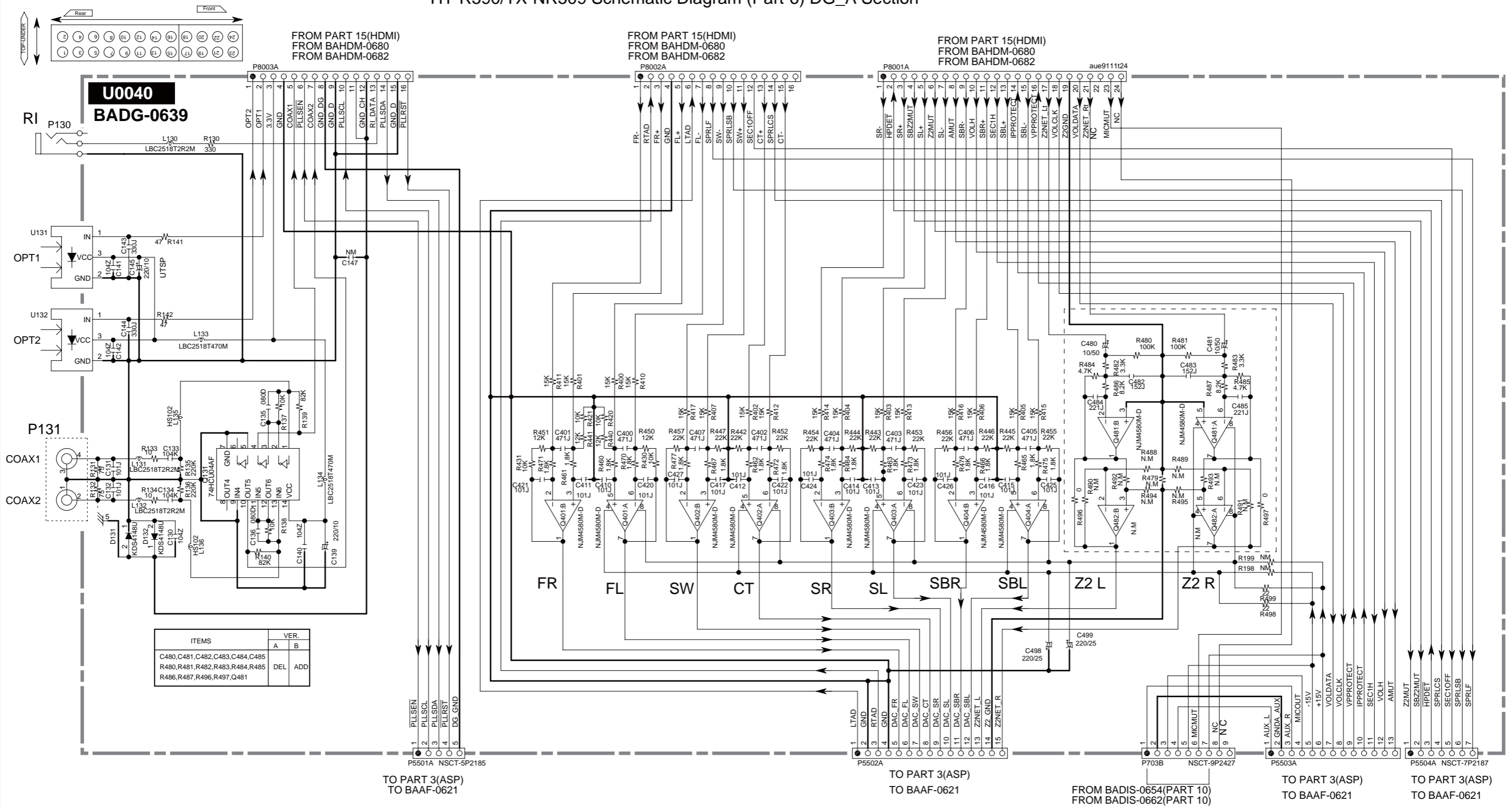

ITEMS	VER.	
	A	B
C480, C481, C482, C483, C484, C485	DEL	ADD
R480, R481, R482, R483, R484, R485	DEL	ADD
R486, R487, R496, R497, Q481	DEL	ADD

TO PART 3(ASP)
TO BAAF-0621

TO PART 3(ASP)
TO BAAF-0621

FROM BADIS-0654(PART 10)
FROM BADIS-0662(PART 10)

TO PART 3(ASP)
TO BAAF-0621

TO PART 3(ASP)
TO BAAF-0621

SCHEMATIC DIAGRAM/ BLOCK DIAGRAM-6

DIGITAL IN/ DAC/ MPU SECTION PART-6

1 TX-NR579/TX-NA579/TX-NR609/TX-NA609/DTR-20.3/DTR-30.3/HT-R690/HT-R990/HT-RC360 Schematic Diagram (Part-6)

DIGITAL IN/DAC/MPU SECTION

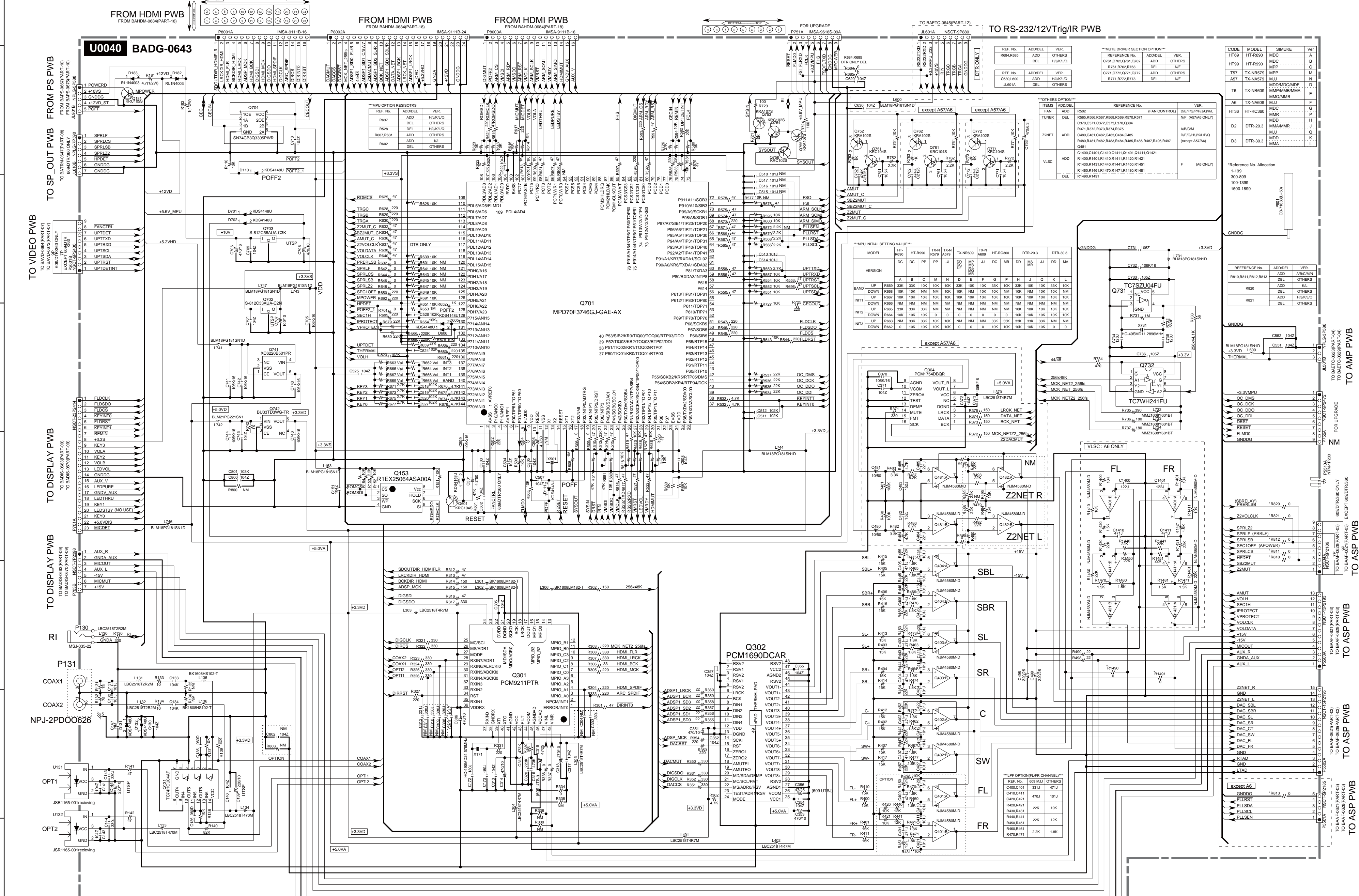

Table with 3 columns: REF. No., ADD/DEL, VER. containing component change records.

Table with 3 columns: REF. No., ADD/DEL, VER. containing component change records.

Table with 3 columns: REF. No., ADD/DEL, VER. containing component change records.

Table with 3 columns: REF. No., ADD/DEL, VER. containing component change records.

Table with 3 columns: REF. No., ADD/DEL, VER. containing component change records.

Table with 3 columns: REF. No., ADD/DEL, VER. containing component change records.

Table with 3 columns: REF. No., ADD/DEL, VER. containing component change records.

Table with 3 columns: REF. No., ADD/DEL, VER. containing component change records.

Table with 3 columns: REF. No., ADD/DEL, VER. containing component change records.

Table with 3 columns: REF. No., ADD/DEL, VER. containing component change records.

Table with 3 columns: REF. No., ADD/DEL, VER. containing component change records.

Table with 3 columns: REF. No., ADD/DEL, VER. containing component change records.

Table with 3 columns: REF. No., ADD/DEL, VER. containing component change records.

Table with 3 columns: REF. No., ADD/DEL, VER. containing component change records.

Table with 3 columns: REF. No., ADD/DEL, VER. containing component change records.

Table with 3 columns: REF. No., ADD/DEL, VER. containing component change records.

Table with 3 columns: REF. No., ADD/DEL, VER. containing component change records.

Table with 3 columns: REF. No., ADD/DEL, VER. containing component change records.

Table with 3 columns: REF. No., ADD/DEL, VER. containing component change records.

Table with 3 columns: REF. No., ADD/DEL, VER. containing component change records.

Table with 3 columns: REF. No., ADD/DEL, VER. containing component change records.

SCHEMATIC DIAGRAM/ BLOCK DIAGRAM-7

VIDEO SECTION PART-7

MODEL No. TX-NR509/ TX-NA509/ HT-R590/ HT-R690/ HT-R990/TX-NR609/ TX-NA609/ HT-RC360/ DTR-20.3/ DTR-30.3 SCHEMATIC DIAGRAM(Part-7) VIDEO SECTION

U0021 BAVD-0664
U0022 BAVD-0672

1
2
3
4
5

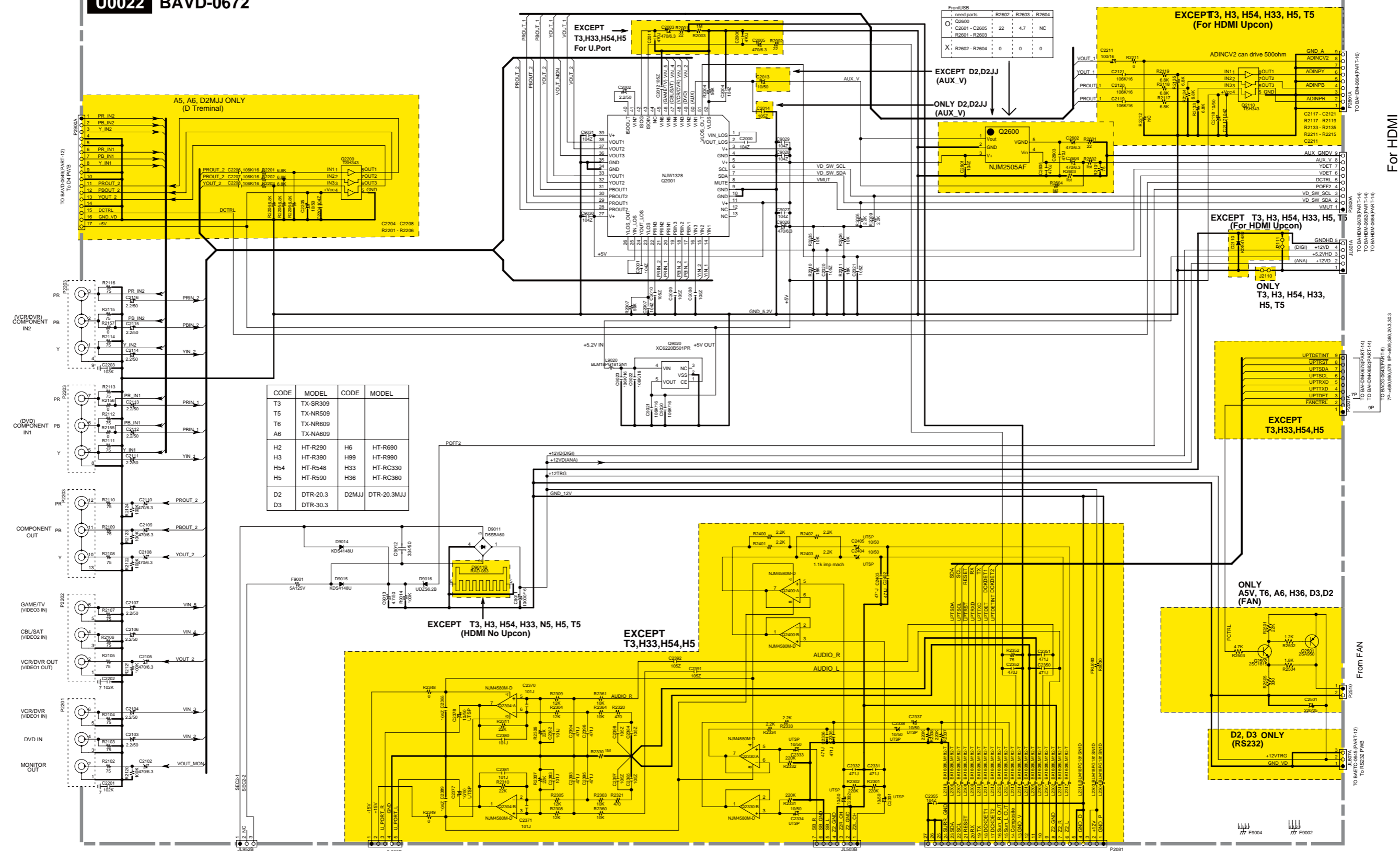

CODE	MODEL	CODE	MODEL
T3	TX-SR309		
T5	TX-NR509		
T6	TX-NR609		
A6	TX-NA609		
H2	HT-R290	H6	HT-R690
H3	HT-R390	H9	HT-R990
H4	HT-R548	H33	HT-RC360
H5	HT-R590	H36	HT-RC360
D2	DTR-20.3	D2MJ	DTR-20.3MJ
D3	DTR-30.3		

FrontUSB
 O: C2600 22 4.7 NC
 X: R2602 - R2604 0 0 0

TO BAETC-0618(PART-4)
TO BAETC-0625(PART-4)
TO BAETC-0631(PART-4)
TO AMP PWB

TO BAAF-0614(PART-3)
TO BAAF-0621(PART-3)
TO BAAF-0628(PART-3)
TO AMP PWB

TO BAAF-0614(PART-3)
TO BAAF-0621(PART-3)
TO BAAF-0628(PART-3)
TO AMP PWB

TO UP-A1L
TO iPod Dock

For HDMI

From FAN

TO BAETC-0618(PART-2)
TO RS232 PWB

SCHEMATIC DIAGRAM/ BLOCK DIAGRAM-7

VIDEO SECTION PART-7

MODEL No. TX-SR309/ HT-R390/ HT-R548/ HT-RC330 SCHEMATIC DIAGRAM (Part-7) VIDEO SECTION

U0022 BAVD-0656

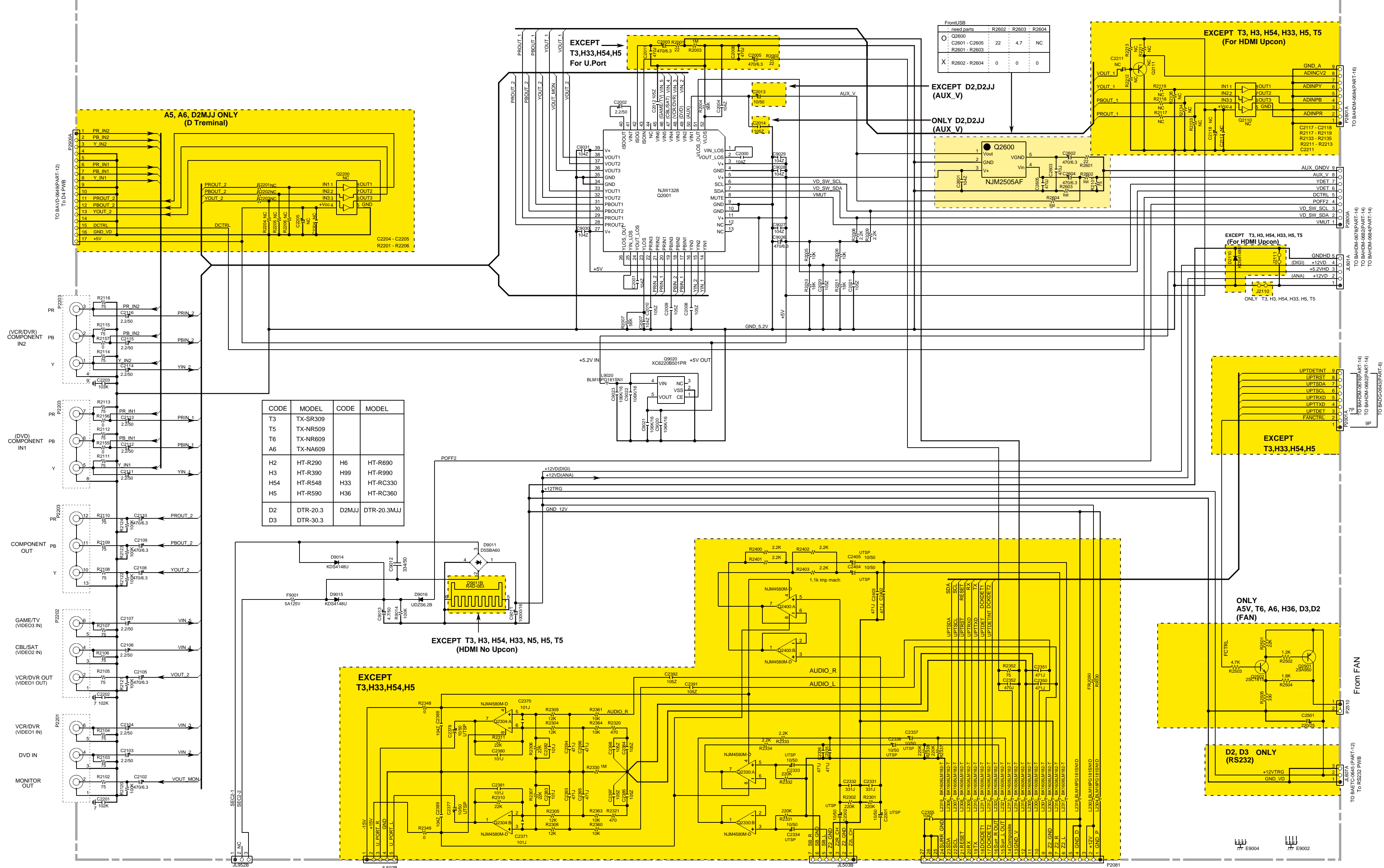

CODE	MODEL	CODE	MODEL
T3	TX-SR309		
T5	TX-NR509		
T6	TX-NR609		
A6	TX-NA609		
H2	HT-R290	H6	HT-R690
H3	HT-R390	H99	HT-R990
H4	HT-R548	H33	HT-RC330
H5	HT-R590	H36	HT-RC360
D2	DTR-20.3	D2MJJ	DTR-20.3MJJ
D3	DTR-30.3		

FrontUSB

Resistor parts	R2602	R2603	R2604
O: Q2600			
C: C2601 - C2605	22	4.7	NC
X: R2602 - R2604	0	0	0

TO BAETC-0618(PART-4)
TO BAETC-0626(PART-4)
TO BAETC-0631(PART-4)
TO AMP PWB

JL502B
TO BAAF-0614(PART-3)
TO BAAF-0621(PART-3)
TO BAAF-0628(PART-3)
TO AMP PWB

TO BAAF-0614(PART-3)
TO BAAF-0621(PART-3)
TO BAAF-0628(PART-3)
TO AMP PWB

TO UP-A1L
TO iPod Dock

TO BAETC-0645(PART-12)
TO RS232 PWB

For HDMI

From FAN

1
2
3
4
5
6
7
8

SCHEMATIC DIAGRAM/ BLOCK DIAGRAM-8

SPEAKER OUT SECTION PART-8 MODEL No. TX-NR609/NA609/HT-RC360/DTR-20.3/30.3 **SCHEMATIC DIAGRAM (PART-8) SP-OUT SECTION**

U0050 BATRM-0647

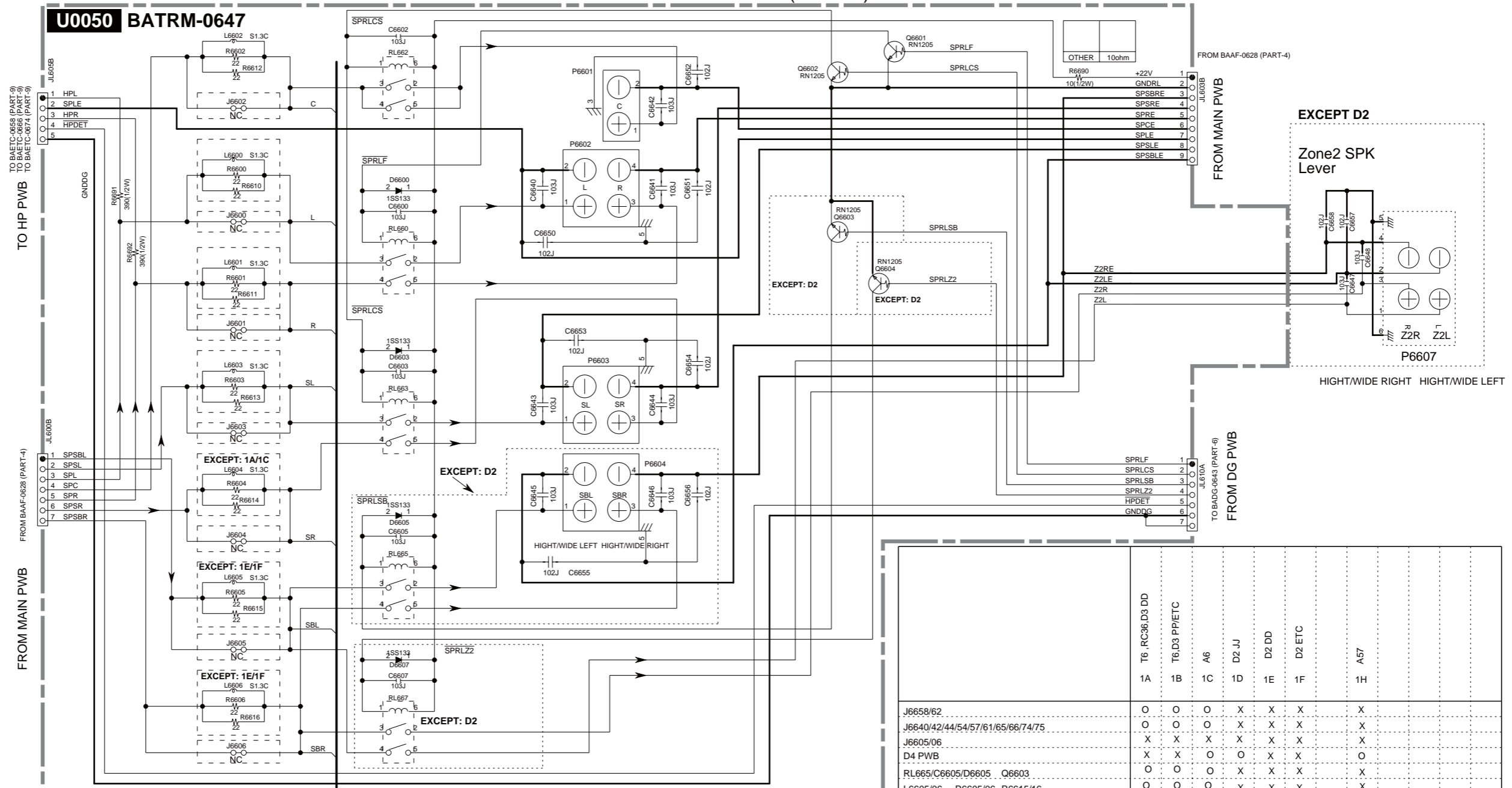

CODE	MODEL	CODE	MODEL
T6	TX-NR609	RC36	HT-RC360
A6	TX-NA609	D2	DTR-20.3
A57	TX-NA579	D3	DTR-30.3

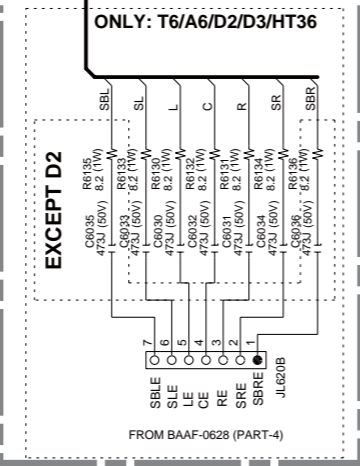

	T6 ,RC36,D3,DD	T6,D3,PP/ETC	A6	D2,JJ	D2,DD	D2,ETC	A57
	1A	1B	1C	1D	1E	1F	1H
J6658/62	O	O	O	X	X	X	X
J6640/42/44/54/57/61/65/66/74/75	O	O	O	X	X	X	X
J6605/06	X	X	O	X	X	X	O
D4 PWB	X	X	O	O	X	X	O
RL665/C6605/D6605 Q6603	O	O	O	X	X	X	X
L6605/06 R6605/06 R6615/16	O	O	O	X	X	X	X
RL667/C6607/D6607 Q6604	O	O	O	X	X	X	X
P6604	O	O	O	X	X	X	X
P6607	O	O	X	X	X	X	X
C6647/48/57/58	X	O	X	X	X	X	X
C6640-44 C6650-54	X	O	X	X	X	O	X
C6645/46 C6655/56	X	O	X	X	X	X	X
C6030-34 R6130-34	O	O	O	O	O	O	X
JL620B	O	O	O	O	O	O	X
C6035/36 R6135/36	O	O	O	X	X	X	X
J6600-04	X	X	X	X	X	X	X
L6600-04 R6600-04 R6610-14	O	O	O	O	O	O	X
J6611/12/81/82	O	O	X	X	X	X	X

1
2
3
4
5

SCHEMATIC DIAGRAM/ BLOCK DIAGRAM-9

DISPLAY SECTION PART-9

Model No. TX-NR309/HT-R290/390/548/590/HT-RC330 Schematic Diagram (Part-9) Display Section

1
2
3
4
5

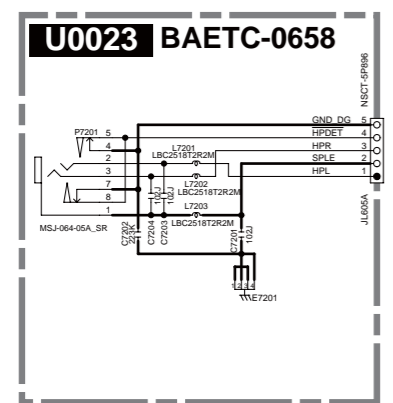

FROM SP_OUT PWB

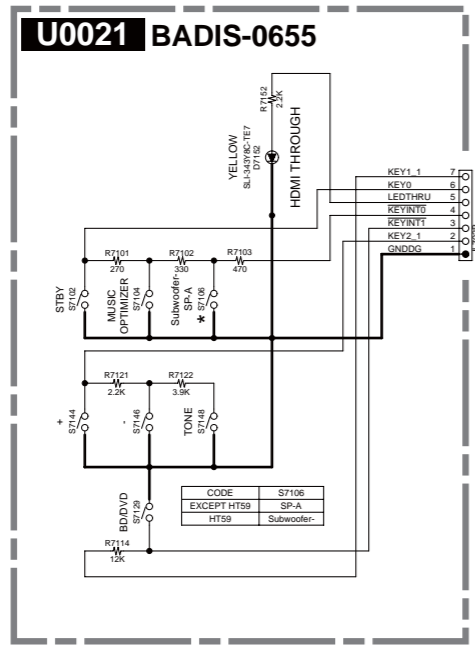

CODE	MODEL
T3	TX-SR309
HT29	HT-R290
HT33	HT-RC330
HT39	HT-R390
HT54	HT-R548
HT59	HT-R590

FROM AMP PWB

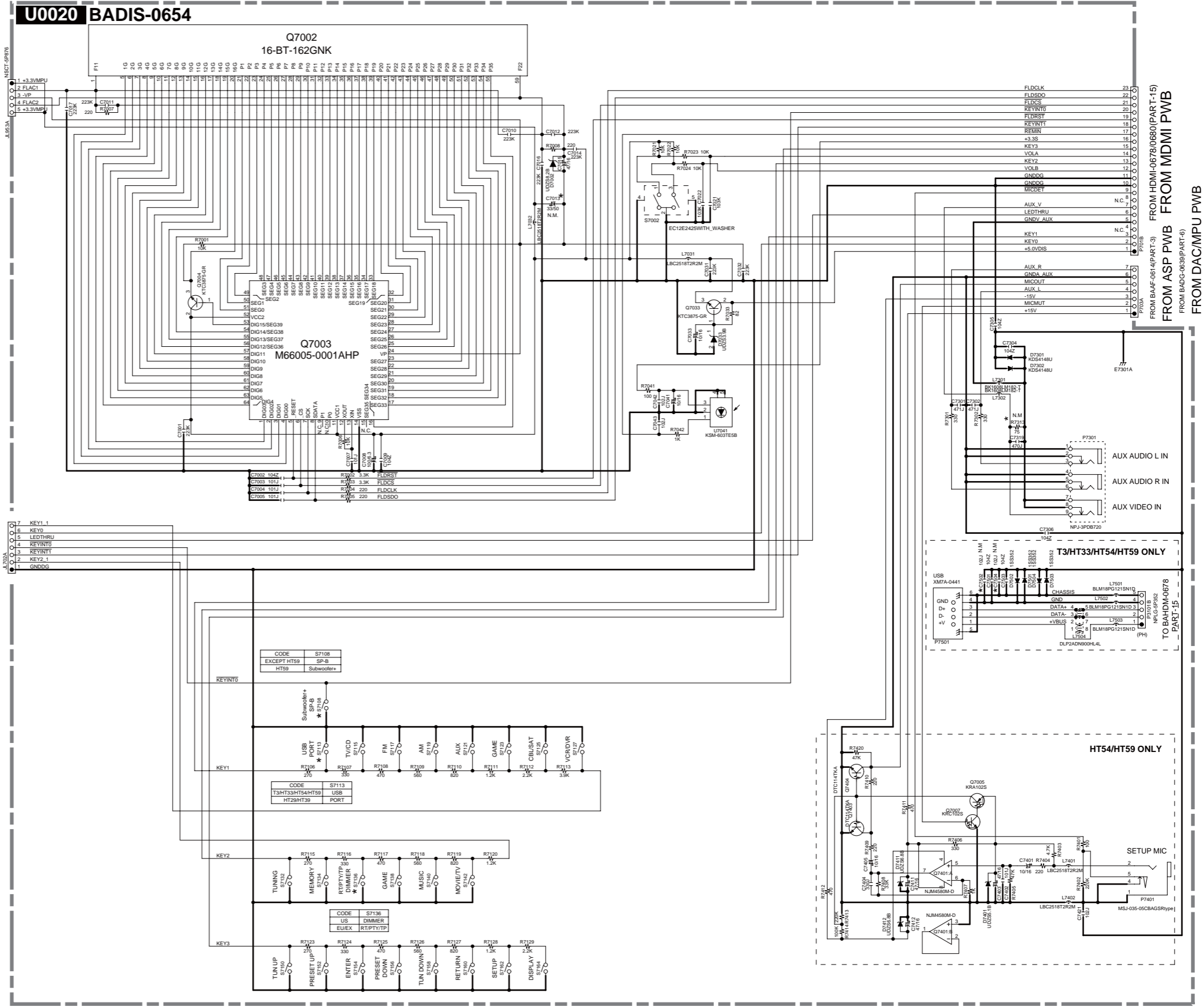

FROM HDMI-0678/0680(PART-15)
FROM BAAF-0614(PART-3)
FROM ASP PWB
FROM MDMI PWB
FROM DAC/MPU PWB

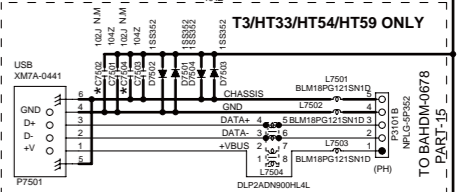

HT54/HT59 ONLY

SETUP MIC

SCHEMATIC DIAGRAM/ BLOCK DIAGRAM-9

DISPLAY SECTION PART-9

Model No. TX-NR509/609/HT-R690/990/HT-RC360 Schematic Diagram (Part-9) Display Section

1

U0020 BADIS-0663

FROM AMP PWB
FROM BAAF-0627/0632(PART-4)

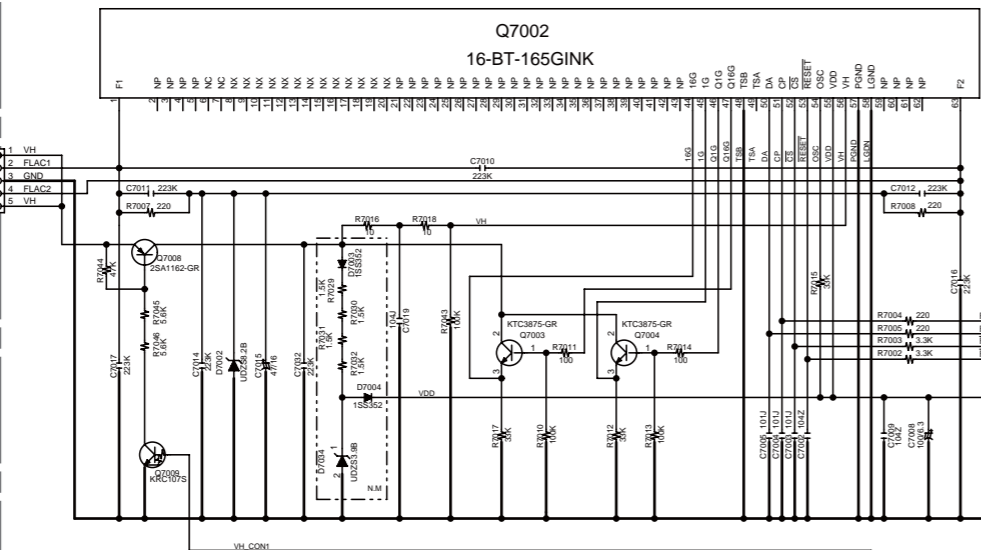

2

U0022 BADIS-0665

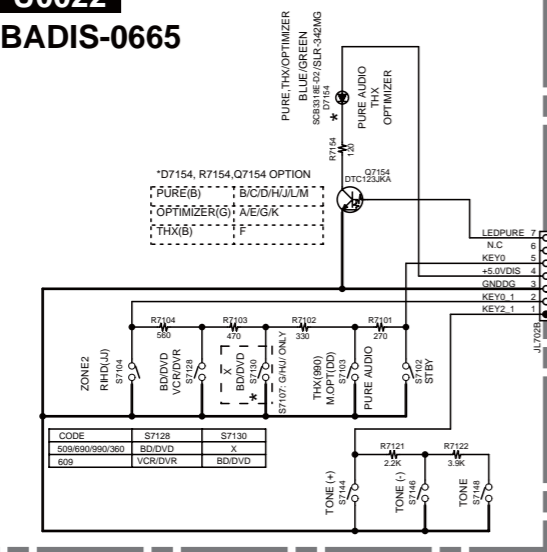

3

CODE	MODEL
T5	TX-NR509
T57	TX-NR579
A57	TX-NA579
HT69	HT-R690
HT99	HT-R990
T6	TX-NR609
A6	TX-NA609
HT36	HT-RC360

4

U0023 BAETC-0666

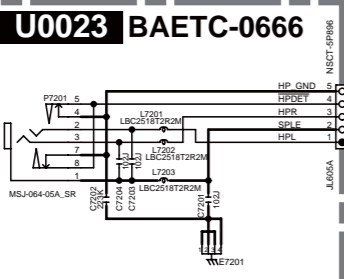

FROM BAFM-0647(PART-8)
FROM BAAF-0621(PART-4)
FROM AMP PWB

5

*Reference No. Allocation:7000-7999

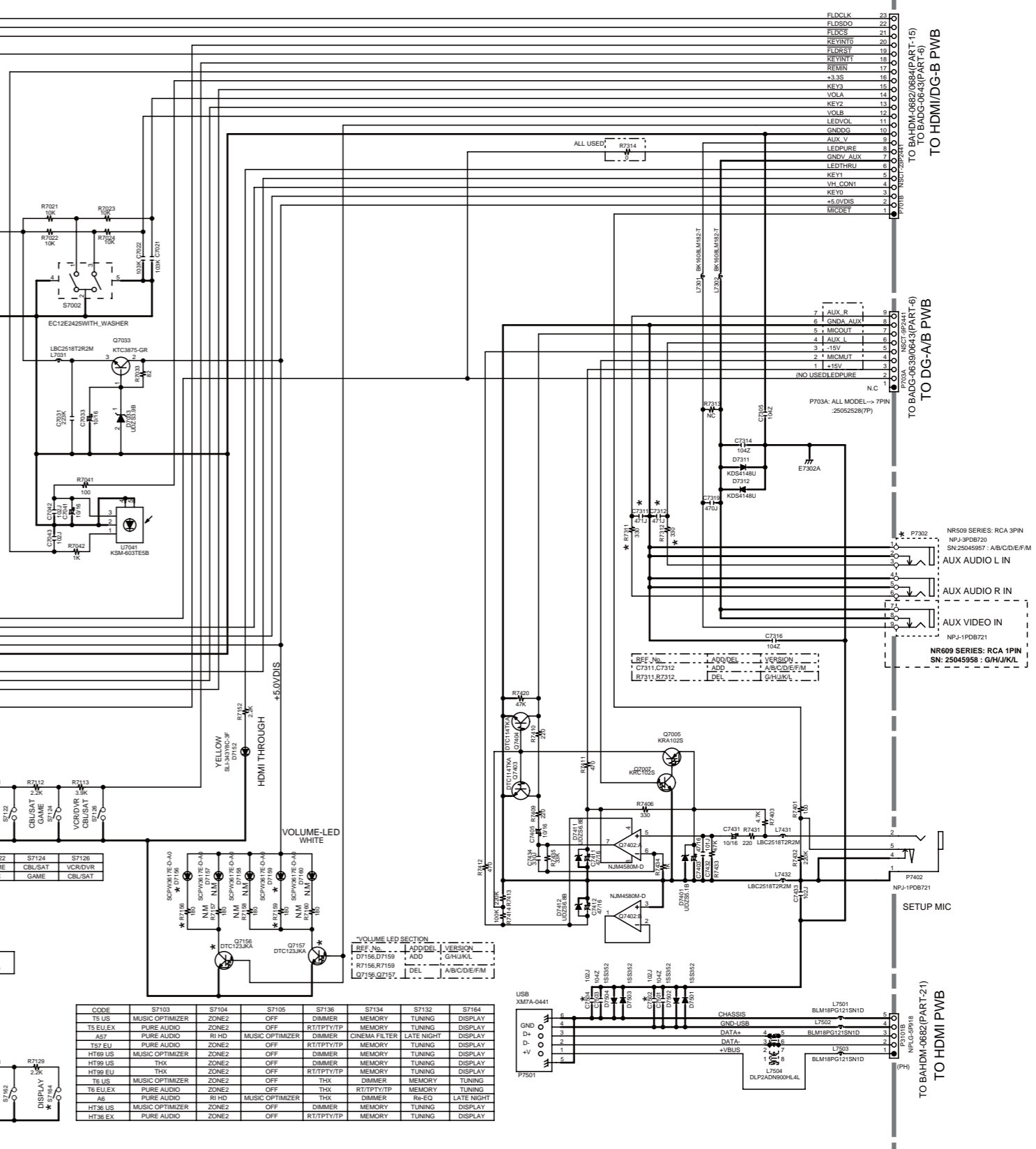

CODE	S7103	S7104	S7105	S7136	S7134	S7132	S7164
T5 US	MUSIC OPTIMIZER	ZONE2	OFF	DIMMER	MEMORY	TUNING	DISPLAY
T5 EU/EX	PURE AUDIO	ZONE2	OFF	RT/PT/TP	MEMORY	TUNING	DISPLAY
A57	PURE AUDIO	RH/D	MUSIC OPTIMIZER	DIMMER	CINEMA FILTER	LATE NIGHT	DISPLAY
T57 EU	PURE AUDIO	ZONE2	OFF	RT/PT/TP	MEMORY	TUNING	DISPLAY
HT69 US	MUSIC OPTIMIZER	ZONE2	OFF	DIMMER	MEMORY	TUNING	DISPLAY
HT69 EU	THX	ZONE2	OFF	DIMMER	MEMORY	TUNING	DISPLAY
HT69 EU	THX	ZONE2	OFF	RT/PT/TP	MEMORY	TUNING	DISPLAY
T6 US	MUSIC OPTIMIZER	ZONE2	OFF	THX	DIMMER	MEMORY	TUNING
T6 EU/EX	PURE AUDIO	ZONE2	OFF	THX	RT/PT/TP	MEMORY	TUNING
A6	PURE AUDIO	RH/D	MUSIC OPTIMIZER	THX	DIMMER	RE-EQ	LATE NIGHT
HT36 US	MUSIC OPTIMIZER	ZONE2	OFF	DIMMER	MEMORY	TUNING	DISPLAY
HT36 EX	PURE AUDIO	ZONE2	OFF	RT/PT/TP	MEMORY	TUNING	DISPLAY

SCHEMATIC DIAGRAM/ BLOCK DIAGRAM-9
DISPLAY SECTION
PART-9

Model No. DTR-20.3/DTR-30.3 Schematic Diagram (Part-09) Display Section

1

2

3

4

5

U0020 BADIS-0670

FROM AMP PWB
FROM BATEC-0632(PART-4)

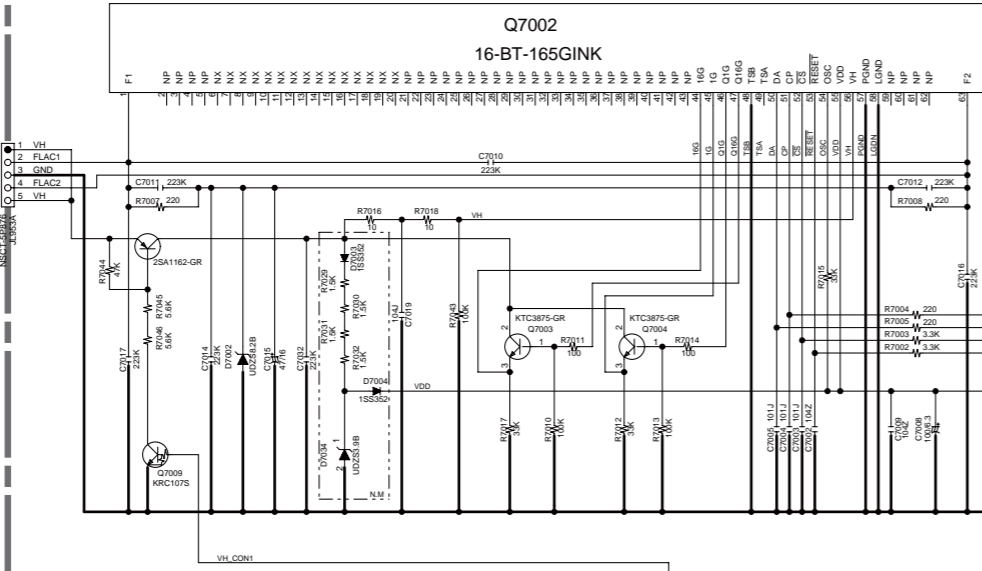

CODE	MODEL
D2	DTR-20.3
D3	DTR-30.3

U0021 BADIS-0671

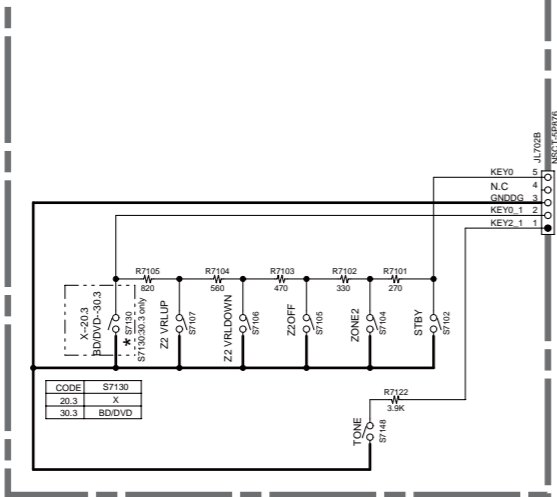

CODE	S7130
20.3	X
30.3	BD/DVD

U0023 BAETC-0674

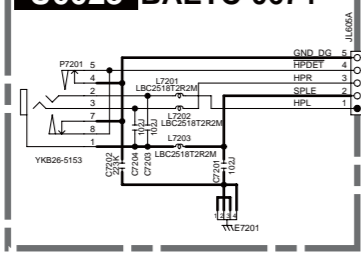

FROM BATRM-0647(PART-8)
FROM SP_OUT PWB

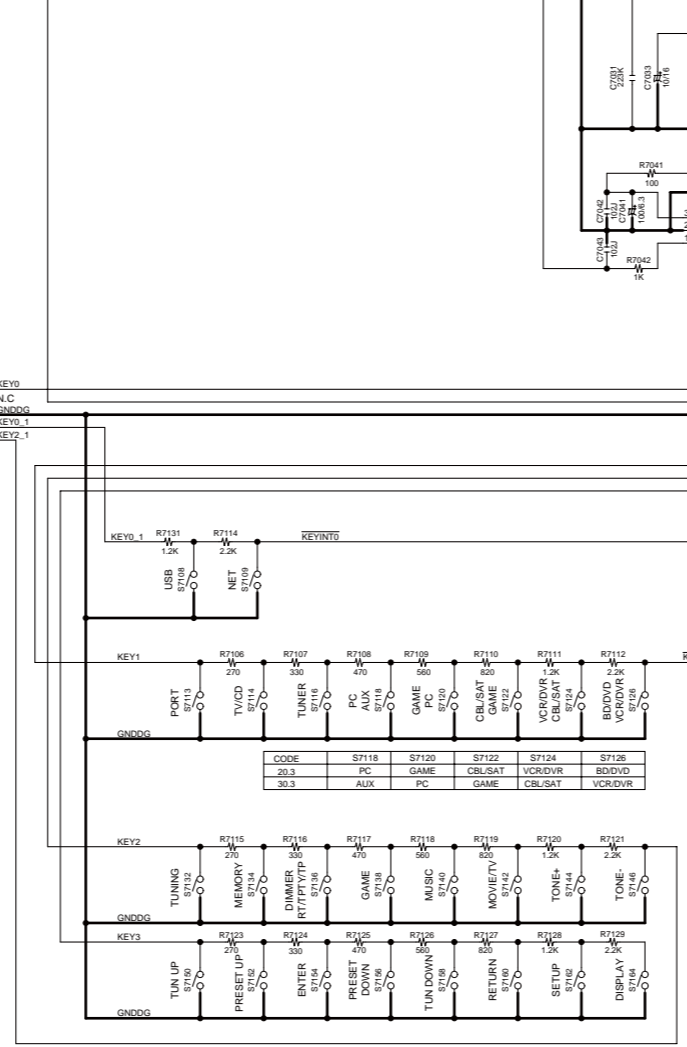

CODE	S7118	S7120	S7122	S7124	S7126
20.3	PC	GAME	CBL/SAT	VCR/DVR	BD/DVD
30.3	AUX	PC	GAME	CBL/SAT	VCR/DVR

CODE	S7136
MDD/MMR	DIMMER
MMA/MMA	RT/TP/TYP

P7560A
NPLG-3P0958
TO BADE-062
PART-10

MODEL	SIMUKE	VER.
DTR-20.3	MDD	A
	MMA_MMR	B
	MJJ	E
DTR-30.3	MDD	C
	MMA	D

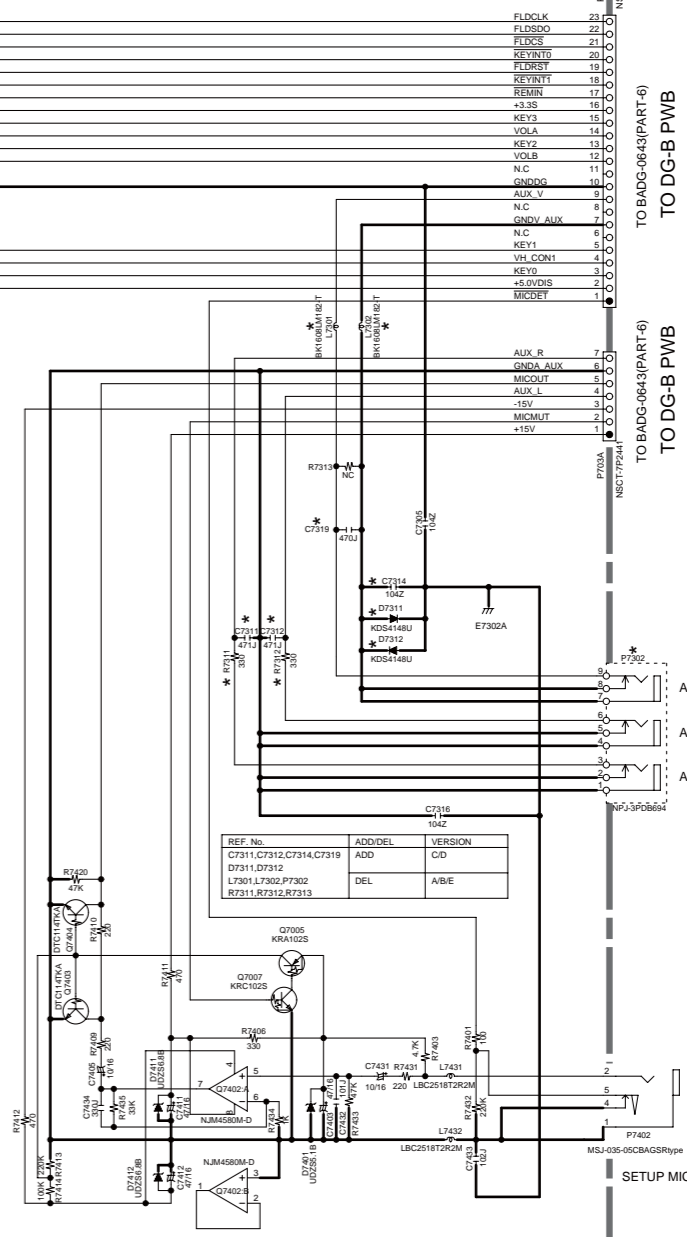

REF. No.	ADDDEL	VERSION
C7311, C7312, C7314, C7319	ADD	C/D
D7311, D7312	DEL	A/B/E
L7301, L7302, P7302		
R7311, R7312, R7313		

TO BADG-0643(PART-6)
TO DG-B PWB

TO BADG-0643(PART-6)
TO DG-B PWB

AUX AUDIO R IN
AUX AUDIO L IN
AUX VIDEO IN

SETUP MIC

*Reference No. Allocation:7000-7999

A

B

C

D

SCHEMATIC DIAGRAM/ BLOCK DIAGRAM-9

DISPLAY SECTION PART-9

1

Model No. DTR-20.3/DTR-30.3 Schematic Diagram
(Part-09) Display Section

2

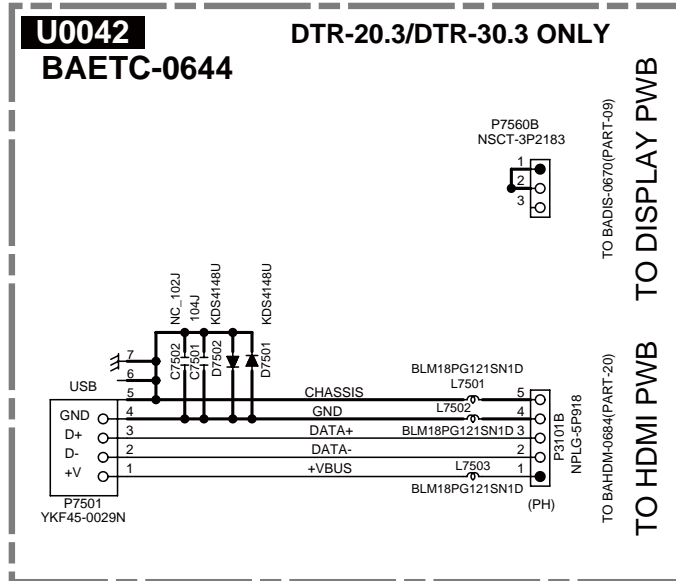

3

4

5

SCHEMATIC DIAGRAM/ BLOCK DIAGRAM-10

POWER SUPPLY SECTION PART-10

Model No. DTR-20.3/DTR-30.3
Schematic Diagram (Part-10) PS Section

- 印は火災、感電の危険に関与する部品の為、必ず指定部品を使用の事。
 - 電圧表示は無番号時に測定した直流電圧を示す。(単位V、入力抵抗100kΩ/V以上の電圧計)
- 記入なき電解コンデンサの単位はμF/VVである。
 - 記入なきコンデンサの単位はpF/50VVである。
- 例 0.30→0.3pF 3.30→3.3pF 3.31→3.30pF 3.33→0.033μF
- 本配線図は基本配線図につき性能改善等により予告なく変更する事がある。

CAUTION



FOR CONTINUED PROTECTION AGAINST FIRE HAZARD, REPLACE ONLY WITH FUSE OF SAME TYPE AND RATING INDICATED.

ATTENTION



AFIN D'ASSURER UNE PROTECTION PERMANENTE CONTRE LES RISQUES D'INCENDIE, REMPLACER UNIQUEMENT PAR UN FUSIBLE DE MEME TYPE ET CALIBRATION COMME INDIQUE.



THIS SYMBOL LOCATED NEAR THE FUSE INDICATES THAT THE FUSE USED IS SLOW OPERATING TYPE FOR CONTINUED PROTECTION AGAINST FIRE FUSE HAZARD, REPLACE WITH SAME TYPE FUSE. FOR FUSE RATING REFER TO THE MAKING ADJACENT TO THE SYMBOL.

CE SYMBOLE INDIQUE QUE LE FUSIBLE UTILISE EST A LENT, E POUR UNE PROTECTION PERMANENTE, UTILISER QUE DES FUSIBLES DE MEME TYPE. CE DARNIER EST INDIQUE LA QU LE PRESENT SYMBOLE EST APPOSE.

CODE	MODEL
D2	DTR-20.3
D3	DTR-30.3

TYPE	AC
D,F	120V / 60Hz
P,M	230-240V / 50Hz
J	100V / 50/60Hz

TYPE	D2	D3
D,F	NPT-1520JQ	NPT-1520JQ
P,M	NPT-1520GQ	NPT-1520GQ
J	NPT-1520JQ	---

U0024 BAPS-0675

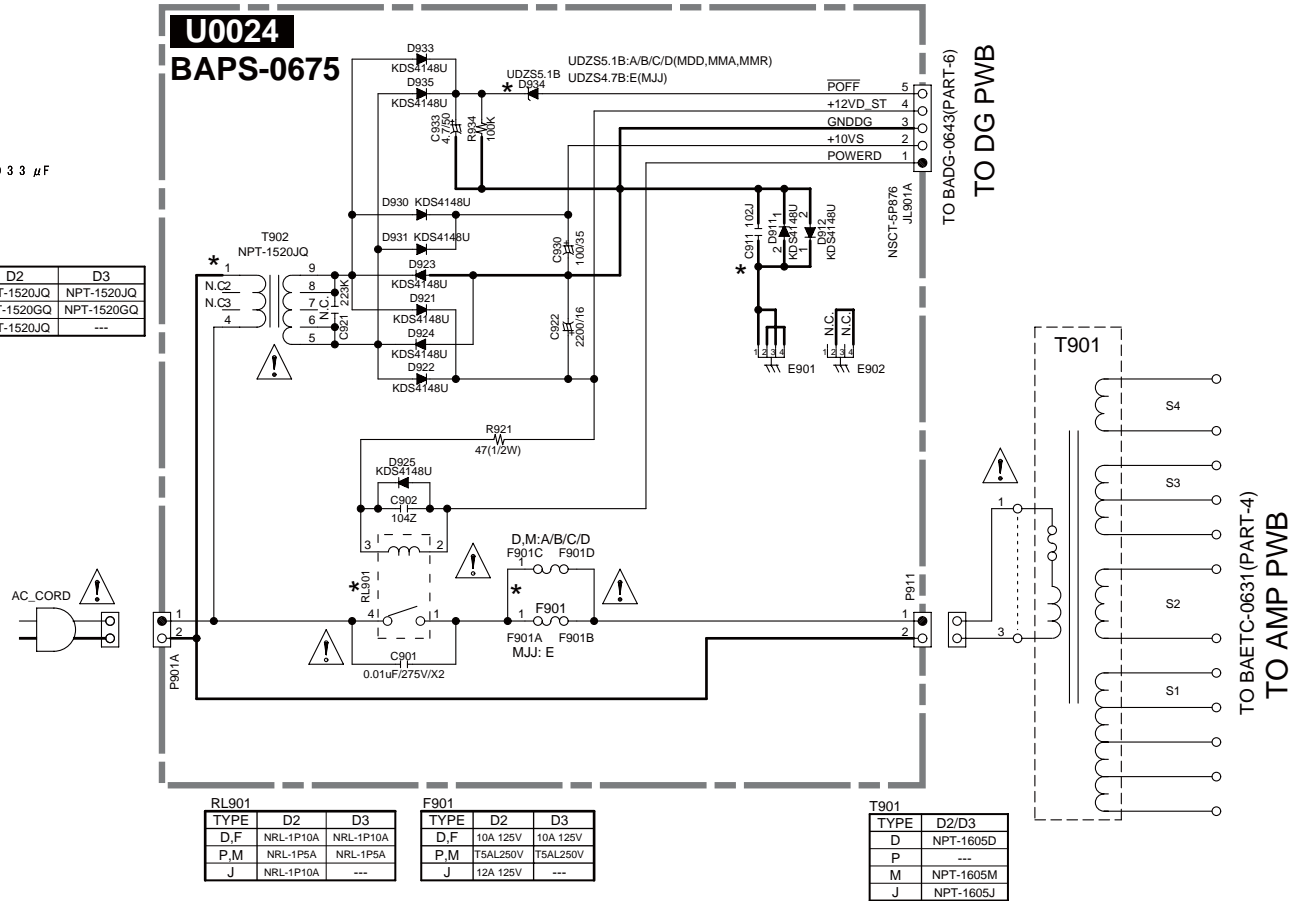

TYPE	D2	D3
D,F	NRL-1P10A	NRL-1P10A
P,M	NRL-1P5A	NRL-1P5A
J	NRL-1P10A	---

TYPE	D2	D3
D,F	10A 125V	10A 125V
P,M	T5AL250V	T5AL250V
J	12A 125V	---

TYPE	D2/D3
D	NPT-1605D
P	---
M	NPT-1605M
J	NPT-1605J

1

2

3

4

A

B

C

D

E

SCHEMATIC DIAGRAM/ BLOCK DIAGRAM-10

PS SECTION PART-10

Model No. TX-NR309/HT-R290/390/548/590/HT-RC330
Schematic Diagram (Part-10) PS Section

NOTE

- THE COMPONENTS IDENTIFIED BY MARK ARE CRITICAL FOR SAFETY. REPLACE ONLY WITH PART NUMBER SPECIFIED.
- VOLTAGE (MEASURED WITH VOLT METER) IS DC VOLTAGE. (NO INPUT SIGNAL)
- ELECTROLYTIC CAPACITORS () ARE IN μ F/WV.
- ALL CAPACITORS ARE IN pF/50V/V UNLESS OTHERWISE NOTED.
EX) 030 \rightarrow 3pF 330 \rightarrow 33pF 331 \rightarrow 330pF 333 \rightarrow 0.033 μ F
- ALL RESISTORS ARE IN OHMS 1/4WATTS UNLESS OTHERWISE NOTED.
THE THICK LINES ON PC BOARD ARE THE PRINTING SIDE OF THE PARTS.
EX) PRINTING SIDE
- CIRCUIT IS SUBJECT TO CHANGE FOR IMPROVEMENT.

CAUTION

FOR CONTINUED PROTECTION AGAINST FIRE HAZARD, REPLACE ONLY WITH FUSE OF SAME TYPE AND RATING INDICATED.



ATTENTION

AFIN D'ASSURER UNE PROTECTION PERMANENTE CONTRE LES RISQUES D'INCENDIE, REMPLACER UNIQUEMENT PAR UN FUSIBLE DE MEME TYPE ET CALIBRATION COMME INDIQUE.



THIS SYMBOL LOCATED NEAR THE FUSE INDICATES THAT THE FUSE USED IS SLOW OPERATING TYPE FOR CONTINUED PROTECTION AGAINST FIRE HAZARD, REPLACE WITH SAME TYPE FUSE. FOR FUSE RATING REFER TO THE MAKING ADJACENT TO THE SYMBOL.



CE SYMBOLE INDIQUE QUE LE FUSIBLE UTILISE EST A LENT, E POUR UNE PROTECTION PERMANENTE, UTILISER QUE DES FUSIBLES DE MEME TYPE. CE DARNIER EST INDIQUE LA QU LE PRESENT SYMBOL EST APPOSE.

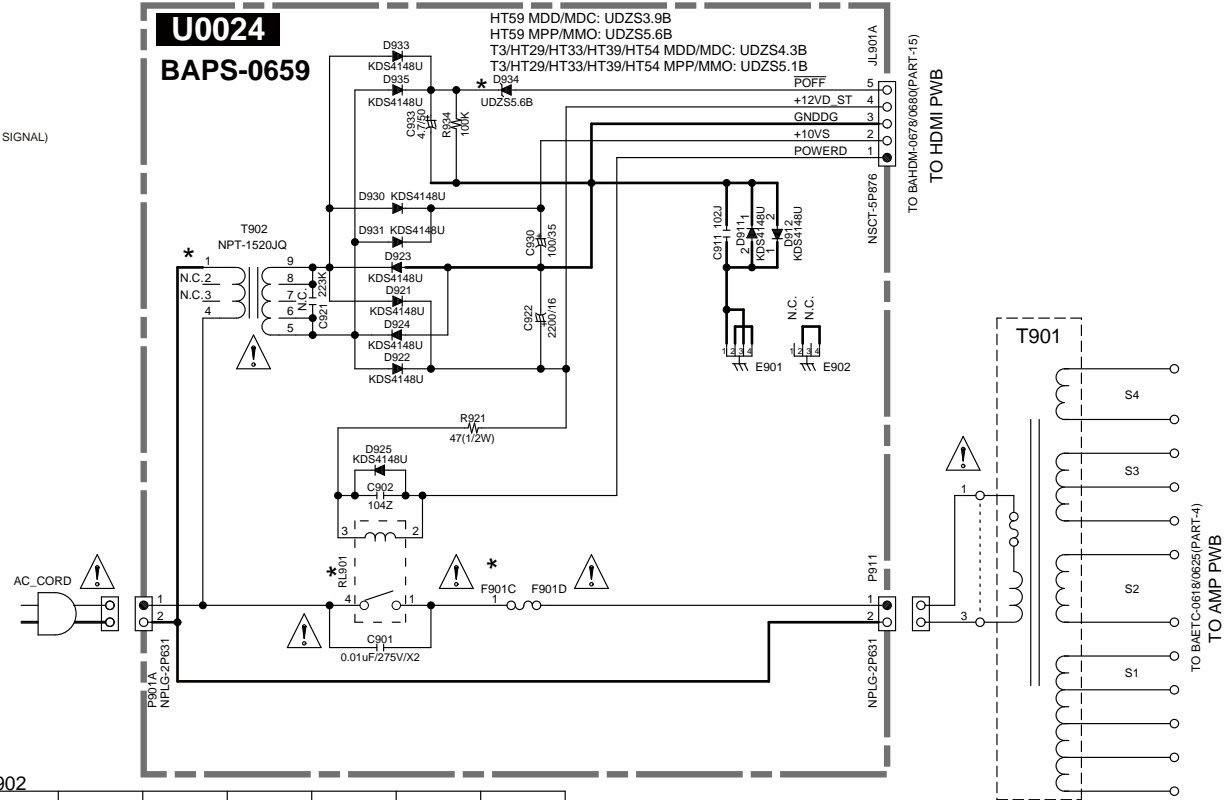

T902

TYPE	T3	HT29	HT33	HT39	HT54	HT59
D,F	1520JQ	1520JQ	1520JQ	1520JQ	---	1520JQ
P,M	1520GQ	---	1520GQ	1520GQ	1520GQ	1520GQ

F901

TYPE	T3	HT29	HT33	HT39	HT54	HT59
D,F	8A 125V	8A 125V	8A 125V	8A 125V	---	8A 125V
P,M	T4AL250V	---	T4AL250V	T4AL250V	T4AL250V	T4AL250V

RL901

TYPE	T3	HT29	HT33	HT39	HT54	HT59
D,F	NRL-1P5A	NRL-1P5A	NRL-1P5A	NRL-1P5A	---	NRL-1P5A
P,M	NRL-1P5A	---	NRL-1P5A	NRL-1P5A	NRL-1P5A	NRL-1P5A

CODE	MODEL
T3	TX-SR309
HT29	HT-R290
HT33	HT-RC330
HT39	HT-R390
HT54	HT-R548
HT59	HT-R590

TYPE	AC
D,F	120V / 60HZ
P,M	230-240V / 50HZ

1

2

3

4

A

B

C

D



E

SCHEMATIC DIAGRAM/ BLOCK DIAGRAM-10

POWER SUPPLY SECTION PART-10

Model No. TX-NR509/609/HT-R690/990/HT-RC360
Schematic Diagram (Part-10) PS Section

- ・印は火災、感電の危険に関与する部品の為、必ず指定部品を使用の事。
 ・電圧表示は無信号時に測定した直流電圧を示す。
 (単位V、入力抵抗100kΩ/V以上の電圧計)
- ・記入なき電解コンデンサの単位はμF/∞Vである。
 ・記入なきコンデンサの単位はpF/50Vである。
 例 0.30→3pF 3.30→33pF 33.1→330pF 333→0.333μF
- ・本配線図は基本配線図につき性能改善等により予告なく変更する事がある。

- * THE COMPONENTS IDENTIFIED BY MARK  ARE CRITICAL FOR SAFETY. REPLACE ONLY WITH PART NUMBER SPECIFIED.
- * VOLTAGE (MEASURED WITH VOLTMETER) IS DC VOLTAGE. (NO INPUT SIGNAL)
- * ELECTROLYTIC CAPACITORS () ARE IN μF/∞V.
- * ALL CAPACITORS ARE IN pF/50V UNLESS OTHERWISE NOTED.
- E X) 0.30→3pF 3.30→33pF 33.1→330pF 333→0.333μF
- * CIRCUIT IS SUBJECT TO CHANGE FOR IMPROVEMENT.

CAUTION

FOR CONTINUED PROTECTION AGAINST FIRE HAZARD, REPLACE ONLY WITH FUSE OF SAME TYPE AND RATING INDICATED.



ATTENTION

AFIN D'ASSURER UNE PROTECTION PERMANENTE CONTRE LES RISQUES D'INCENDIE, REMPLACER UNIQUEMENT PAR UN FUSIBLE DE MEME TYPE ET CALIBRATION COMME INDIQUE.



THIS SYMBOL LOCATED NEAR THE FUSE INDICATES THAT THE FUSE USED IS SLOW OPERATING TYPE FOR CONTINUED PROTECTION AGAINST FIRE FUSE HAZARD. REPLACE WITH SAME TYPE FUSE. FOR FUSE RATING REFER TO THE MAKING ADJACENT TO THE SYMBOL.



CE SYMBOLE INDIQUE QUE LE FUSIBLE UTILISE EST A LENT, E POUR UNE PROTECTION PERMANENTE. UTILISER QUE DES FUSIBLES DE MEME TYPE. CE DERNIER EST INDIQUE LA QU LE PRESENT SYMBOLE EST OPPOSE.

T902				
TYPE	T5	A5	HT69	HT99
D,F	NPT-1520JQ	---	NPT-1520JQ	NPT-1520JQ
P,M	NPT-1520GQ	---	---	NPT-1520GQ
J	---	NPT-1520JQ	---	---

T901			
TYPE	T6	A6	HT36
D,F	NPT-1520JQ	---	NPT-1520JQ
P,M	NPT-1520GQ	---	NPT-1520GQ
J	---	NPT-1520JQ	---

CODE	MODEL
T5	TX-NR509
	TX-NR579
A5	TX-NA579
HT69	HT-R690
HT99	HT-R990
T6	TX-NR609
A6	TX-NA609
HT36	HT-RC360

TYPE	AC
D,F	120V / 60HZ
P,M	230-240V / 50HZ
J	100V / 50/60HZ

F901							
TYPE	T5	A5	HT69	HT99	T6	A6	HT36
D,F	8A 125V	---	8A 125V	8A 125V	10A 125V	---	10A 125V
P,M	T4AL250V	---	---	T4AL250V	TSAL250V	---	TSAL250V
J	---	10A 125V	---	---	---	12A 125V	---

RL901							
TYPE	T5	A5	HT69	HT99	T6	A6	HT36
D,F	NRL-1P5A	---	NRL-1P5A	NRL-1P5A	NRL-1P10A	---	NRL-1P10A
P,M	NRL-1P5A	---	---	NRL-1P5A	NRL-1P5A	---	NRL-1P5A
J	---	NRL-1P10A	---	---	---	NRL-1P10A	---

T901							
TYPE	T5	A5	HT69	HT99	T6	A6	HT36
D,F	NPT-1604D	---	NPT-1604D	NPT-1604D	NPT-1605D	---	NPT-1605D
P	NPT-1604P	---	---	NPT-1604P	NPT-1605M	---	---
M	NPT-1604M	---	---	---	NPT-1605M	---	NPT-1605M
J	---	NPT-1604J	---	---	---	NPT-1605J	---

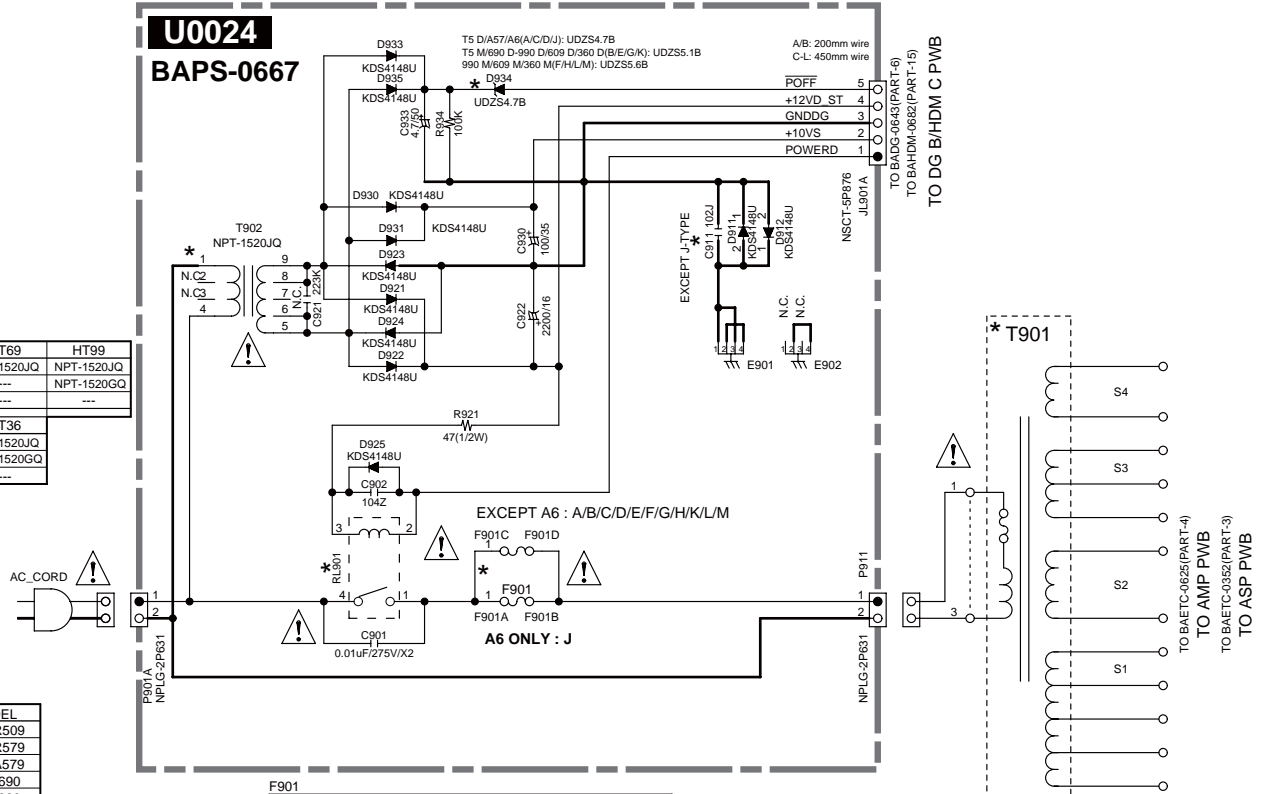

1

2

3

4

A

B

C

D

E

SCHEMATIC DIAGRAM/ BLOCK DIAGRAM-11

D4 TERMINAL SECTION PART-11

MODEL NO. TX-NA579/NA609/DTR-20.3(JJ)

SCHEMATIC DIAGRAM (PART-11) D4 SECTION

1

2

3

4

U0053

BAVD-0649

PART-11 (D Terminal)

TX-NA579/NA609/DTR-20.3(JJ) USE

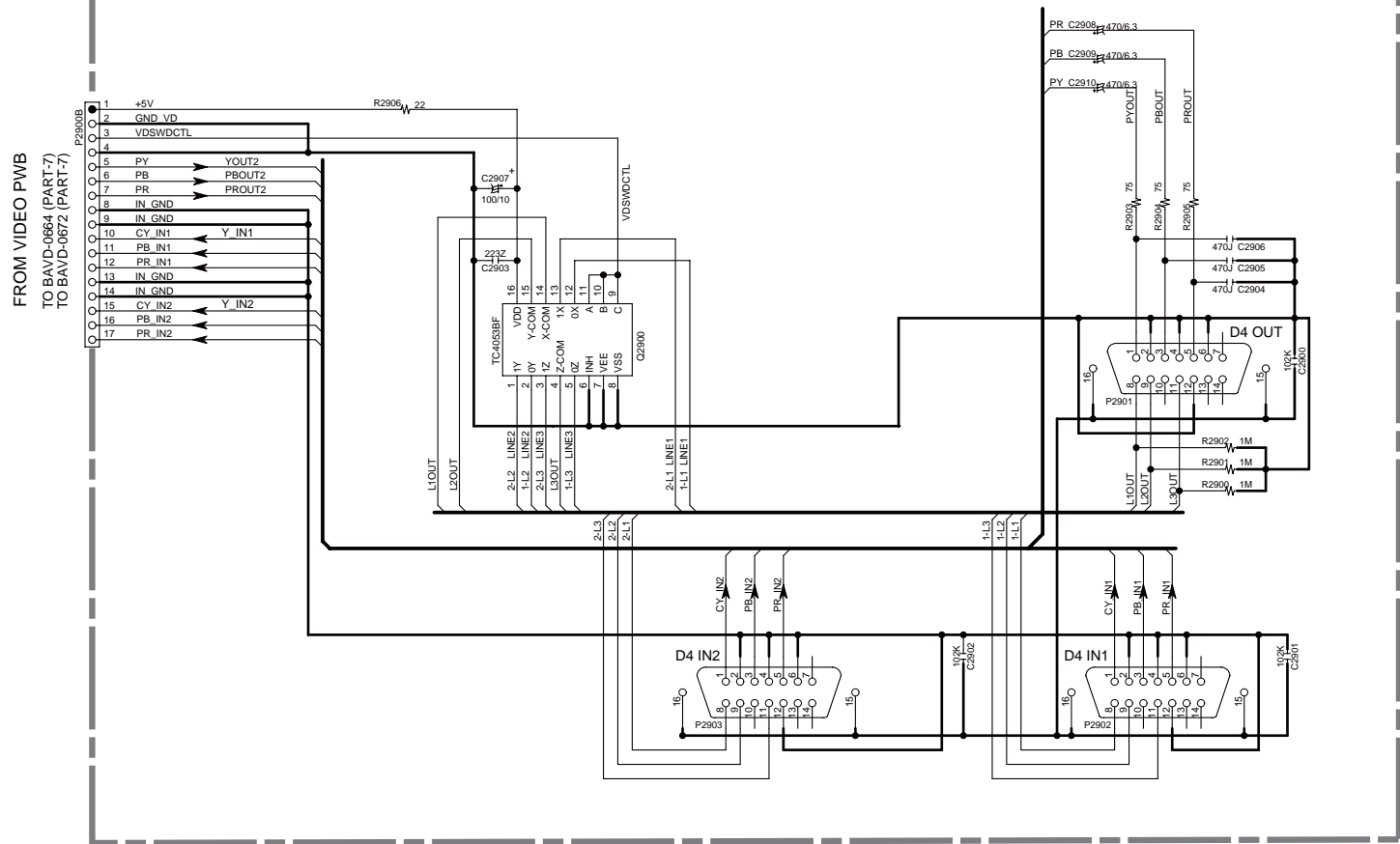

CODE	MODEL	CODE	MODEL
T6	TX-NR609	RC36	HT-RC360
A6	TX-NA609	D2	DTR-20.3
A57	TX-NA579	D3	DTR-30.3

A

B

C

D

E

SCHEMATIC DIAGRAM/ BLOCK DIAGRAM-12

RS-232/ 12V TRIG./ IR SECTION PART-12

DTR-20.3/30.3 Schematic Diagram RS-232/12VTrig/IR Section (PART-12)

1

2

3

4

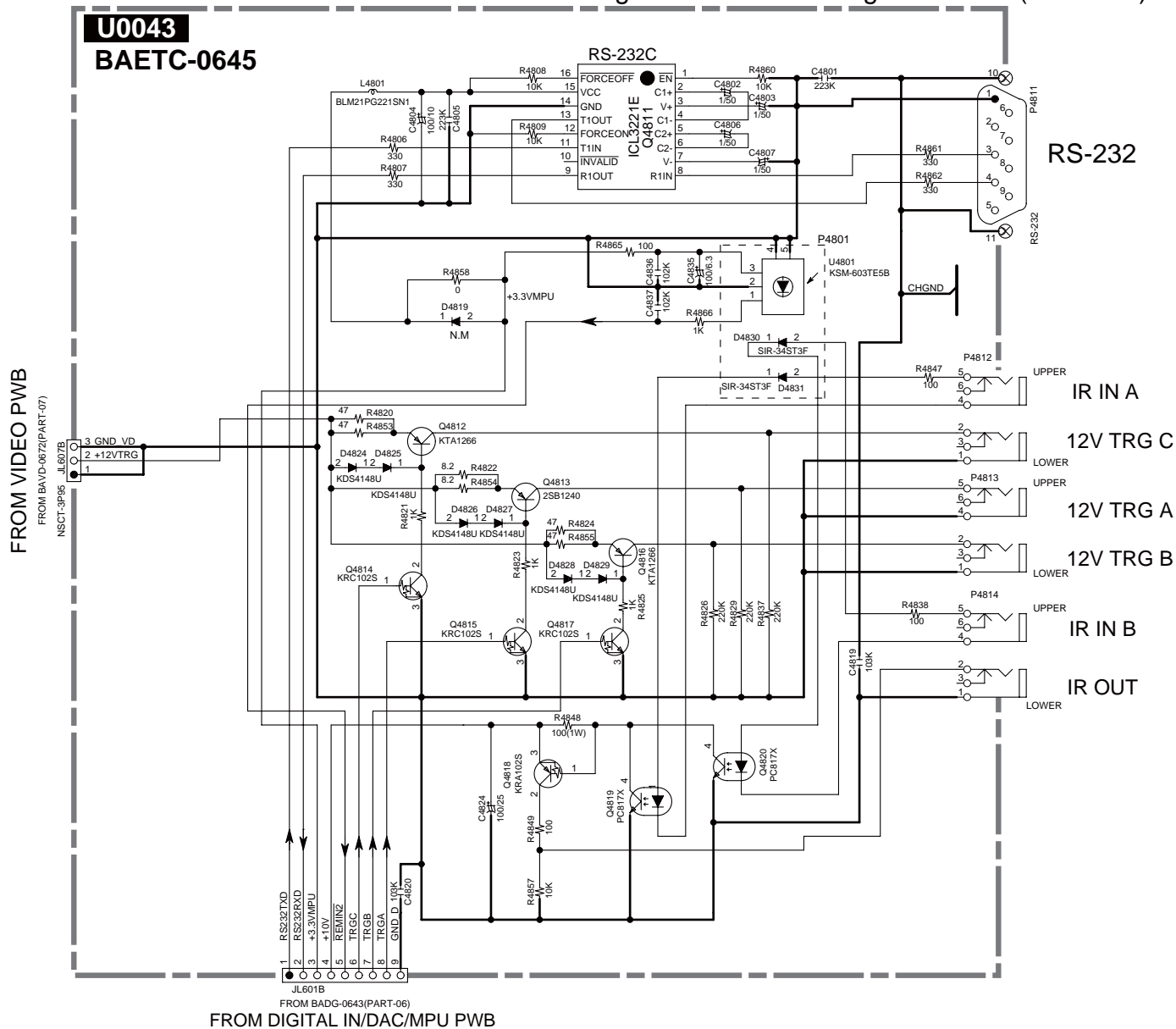

A

B

C

D

E

SCHEMATIC DIAGRAM/ BLOCK DIAGRAM-13

FRONT HDMI SECTION
PART-13

1

Model No. TX-NR(A)609,DTR-30.3,HT-RC360 SCHEMATIC DIAGRAM (PART-13) FRONT HDMI SECTION

2

3

4

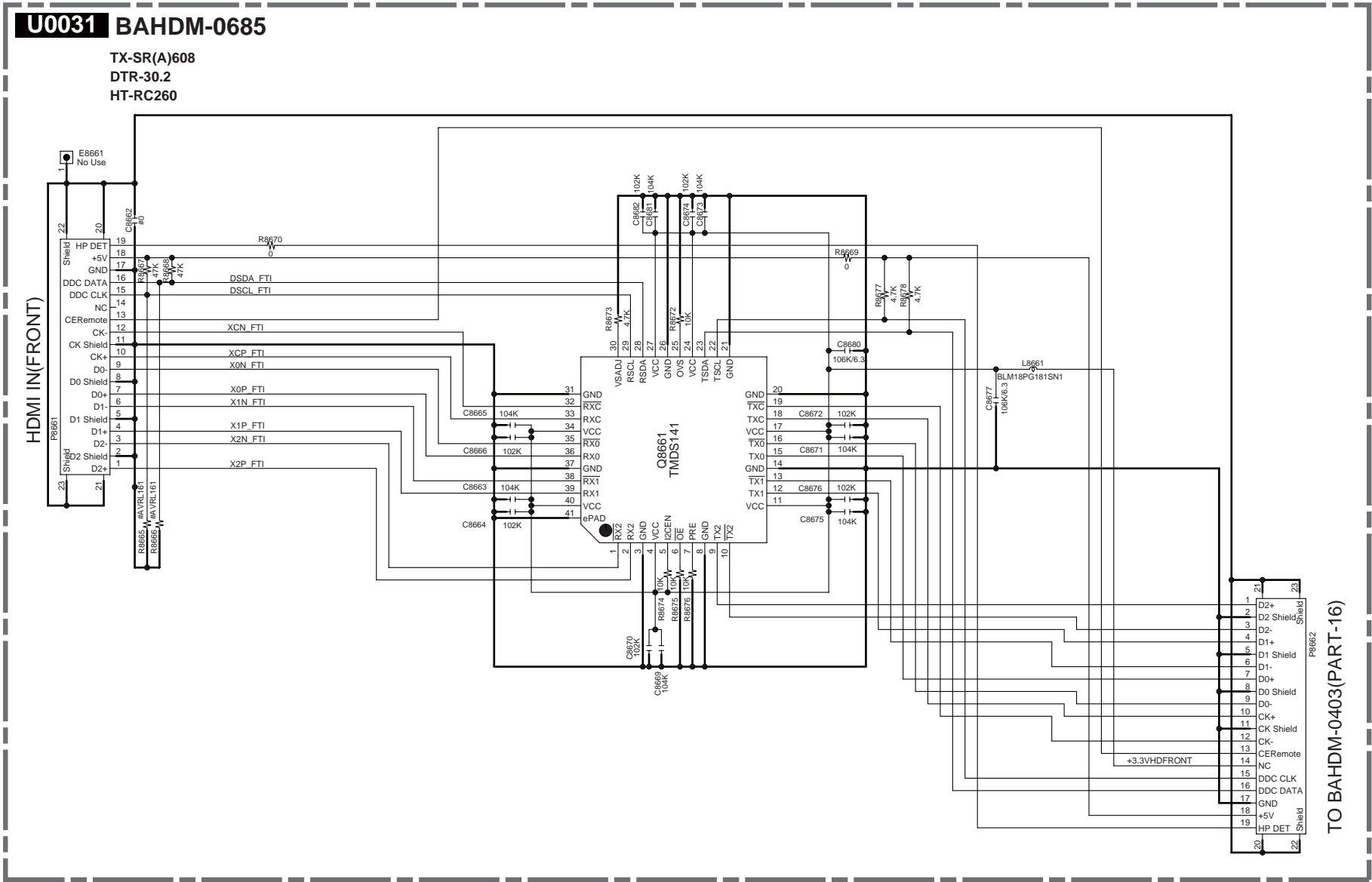

SCHEMATIC DIAGRAM/
BLOCK DIAGRAM-14

Model No. TX-NR509/TX-NA509/TX-NA509V SCHEMATIC DIAGRAM (PART-14)

MPU Section

1

MPU SECTION
PART-14

2

3

4

5

U0030 BAHDM-0680

MAIN MICOM

UPGRADE

J-TAG

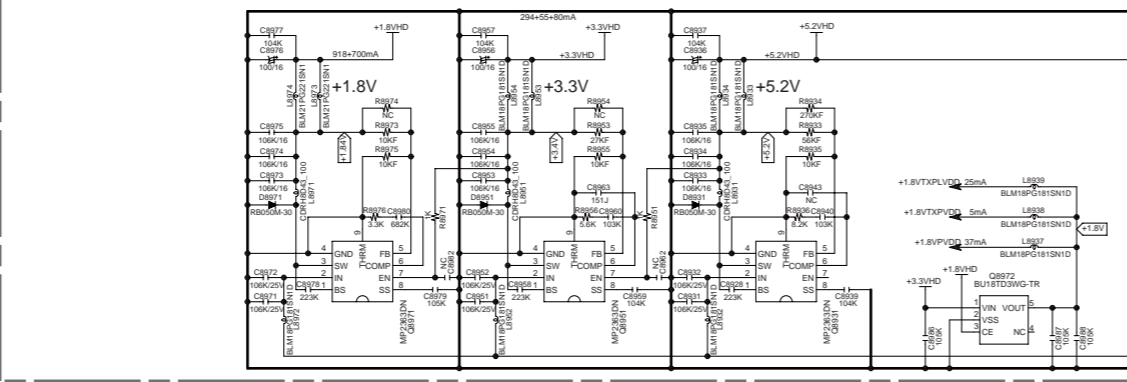
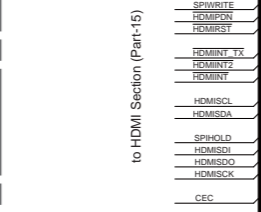
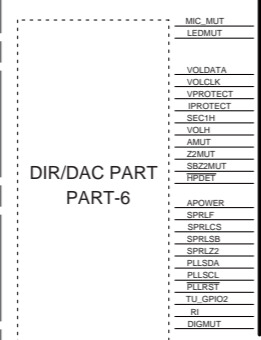
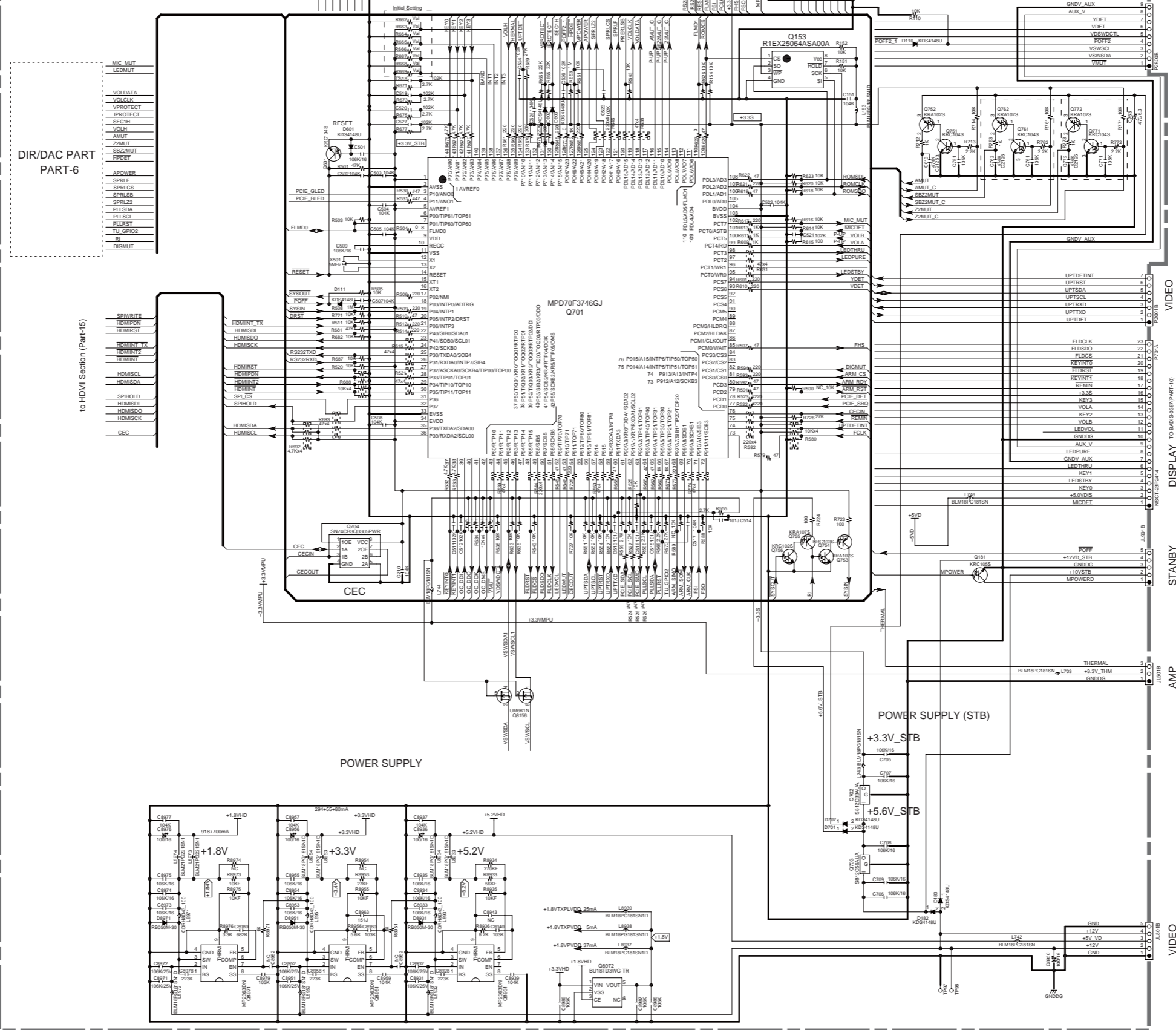

POWER SUPPLY (STB)



SCHEMATIC DIAGRAM/
BLOCK DIAGRAM-14
MPU SECTION PART-14

Model No. TX-SR309/ HT-R290/ HT-R390/ HT-R548/ HT-RC330 Schematic Diagram (Part-14) MPU Section

1
2
3
4
5

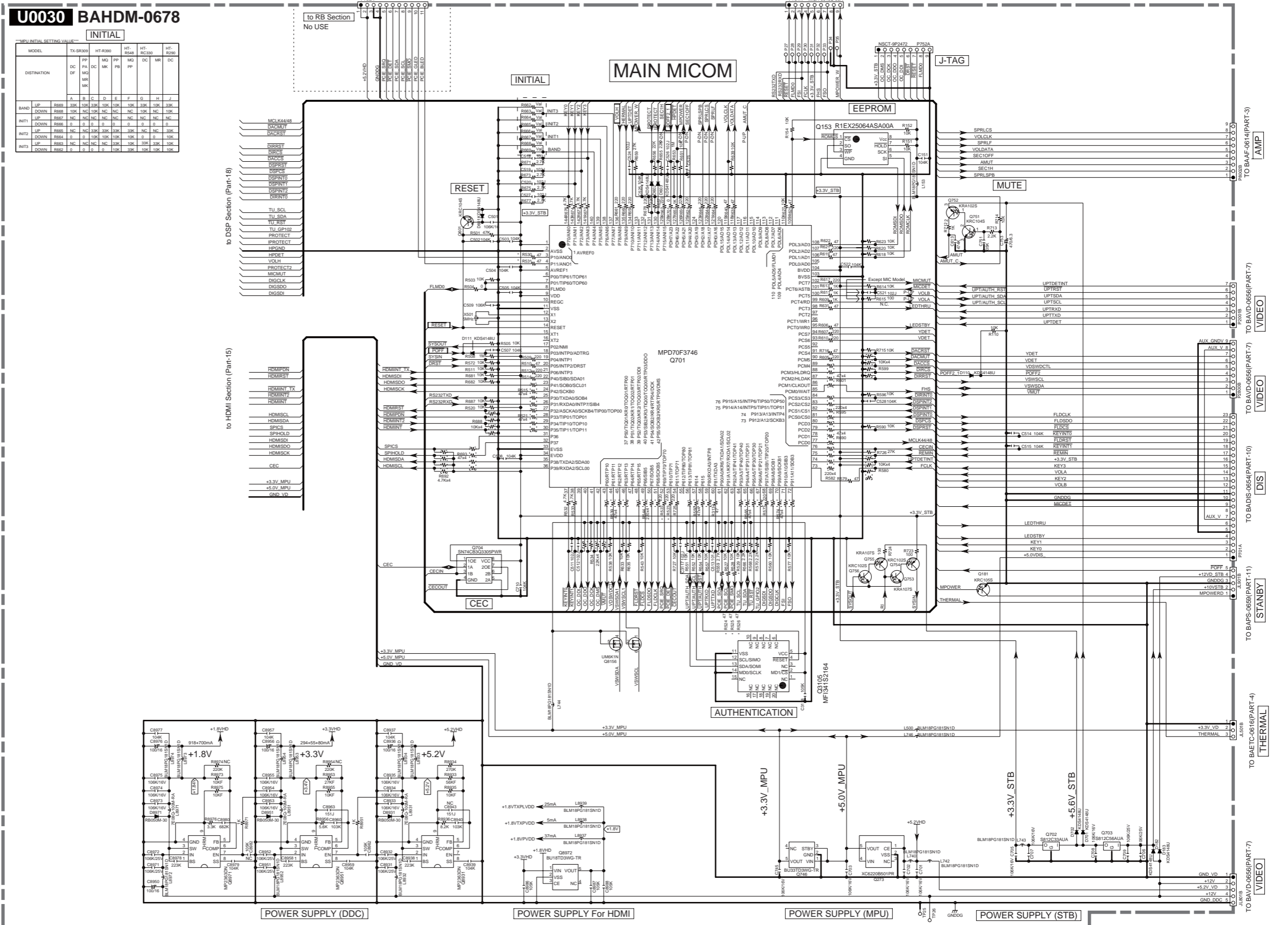

SCHEMATIC DIAGRAM-14

VMPU/ POWER SECTION PART-14

Model No. TX-NR(A)579, TX-NR(A)609, HT-RC360, DTR-20.3, DTR-30.3
Schematic Diagram (Part-14) VMPU/POWER SUPPLY Section

U0030 BAHDM-0684

1
2
3
4
5

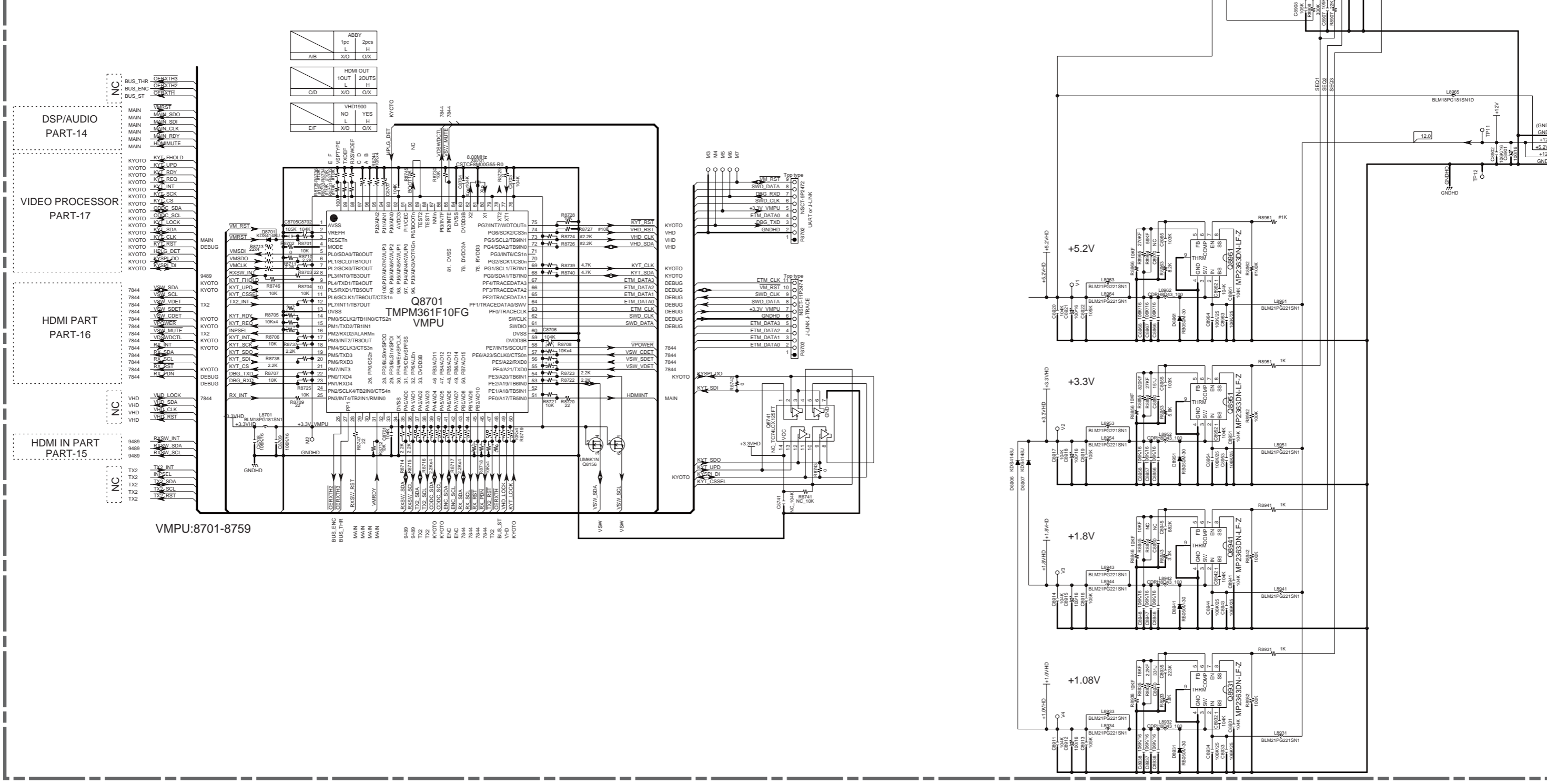

POWER SUPPLY

DSP/AUDIO
PART-18

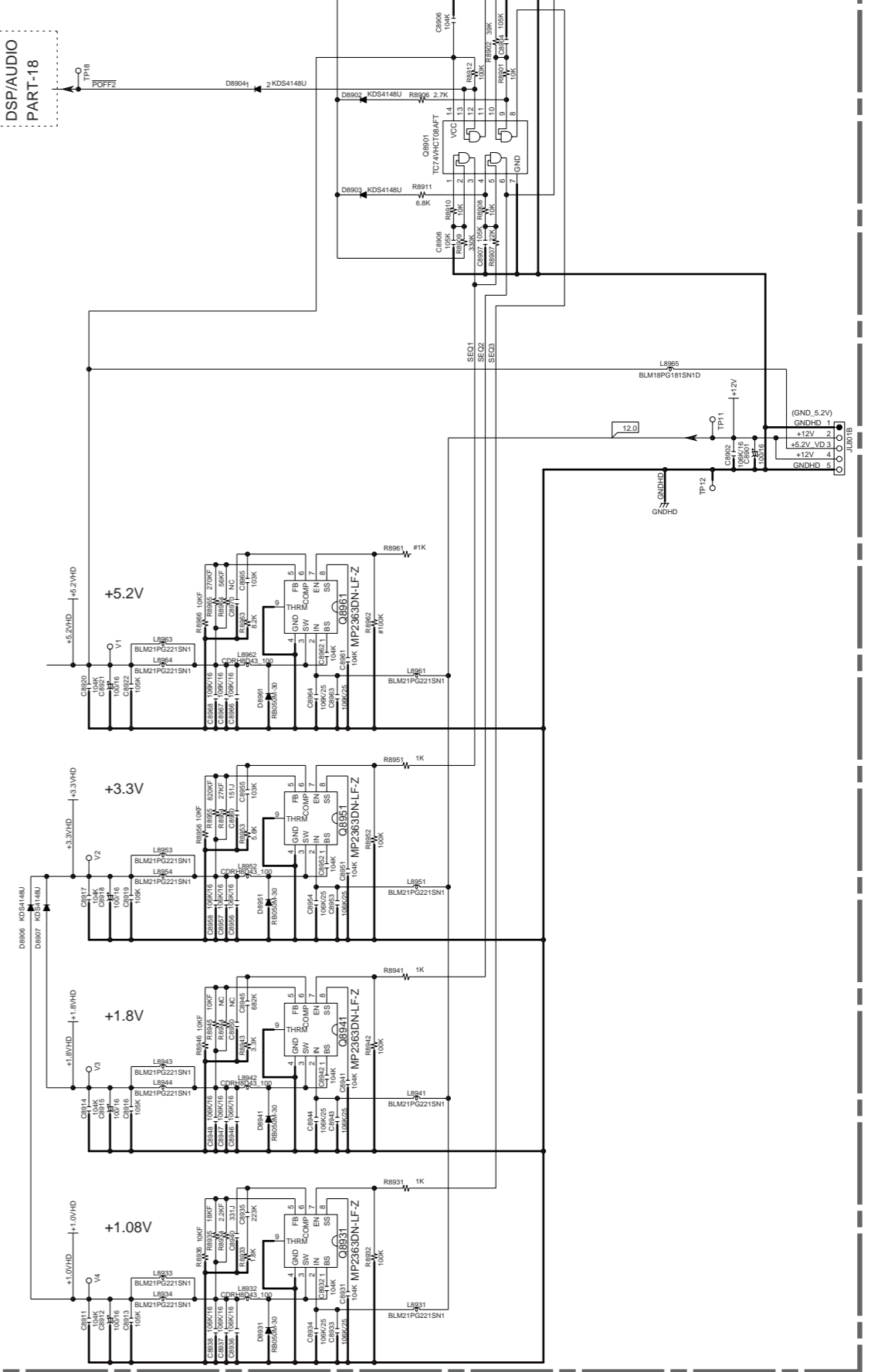

A B C D E F G H I J K
SCHEMATIC DIAGRAM/ BLOCK DIAGRAM-15

HDMI INPUT SWITCH SECTION
PART-15

Model No. TX-NR(A)579, TX-NR(A)609, HT-RC360, DTR-20.3, DTR-30.3

SCHEMATIC DIAGRAM (PART-15)
HDMI INPUT SWITCH SECTION

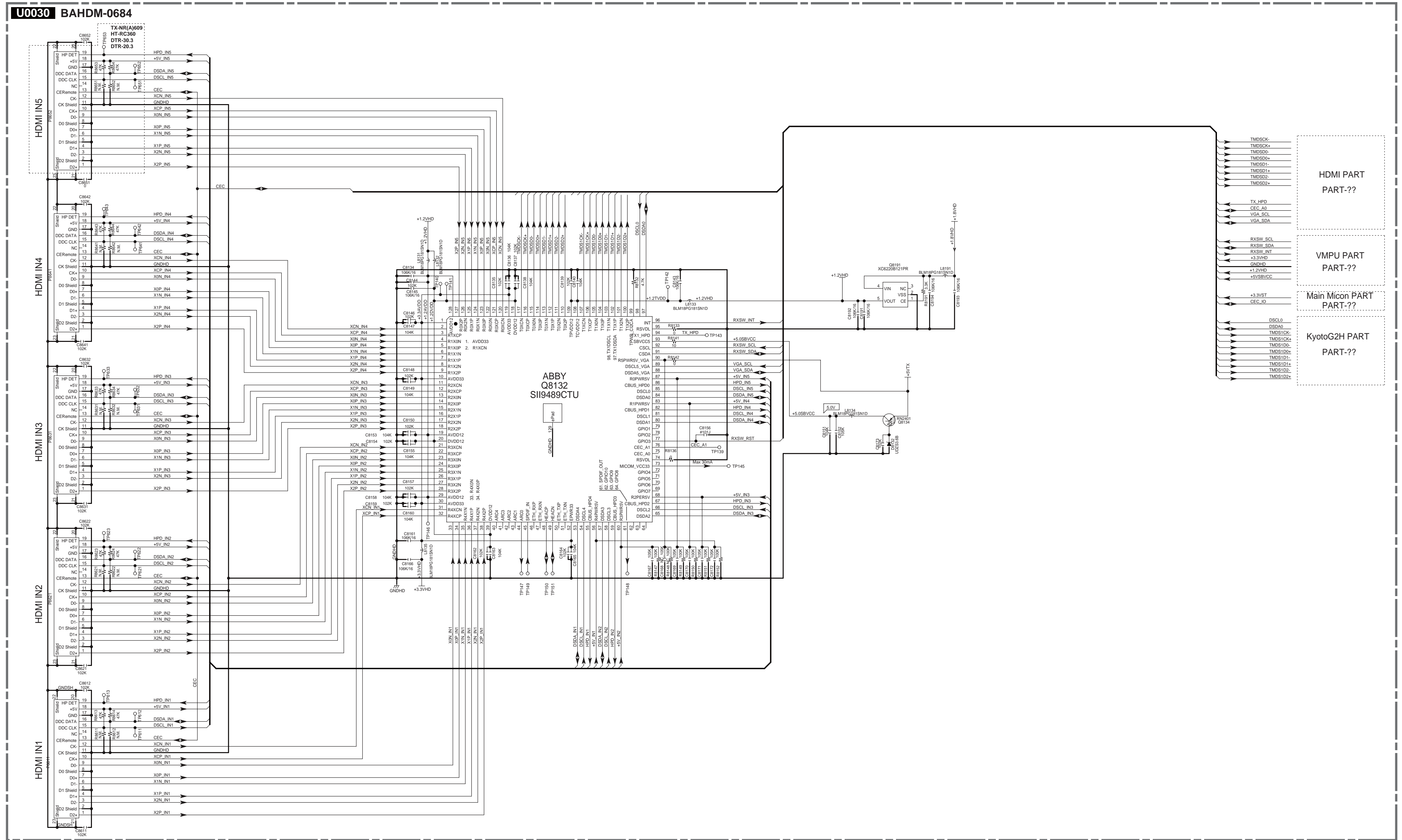

1
2
3
4
5
6
7
8

SCHEMATIC DIAGRAM/ BLOCK DIAGRAM-15
HDMI RX_TX SECTION PART-15

Model No. TX-NR509/TX-NA509/TX-NA509V
SCHEMATIC DIAGRAM (PART-15)
HDMI RX_TX Section

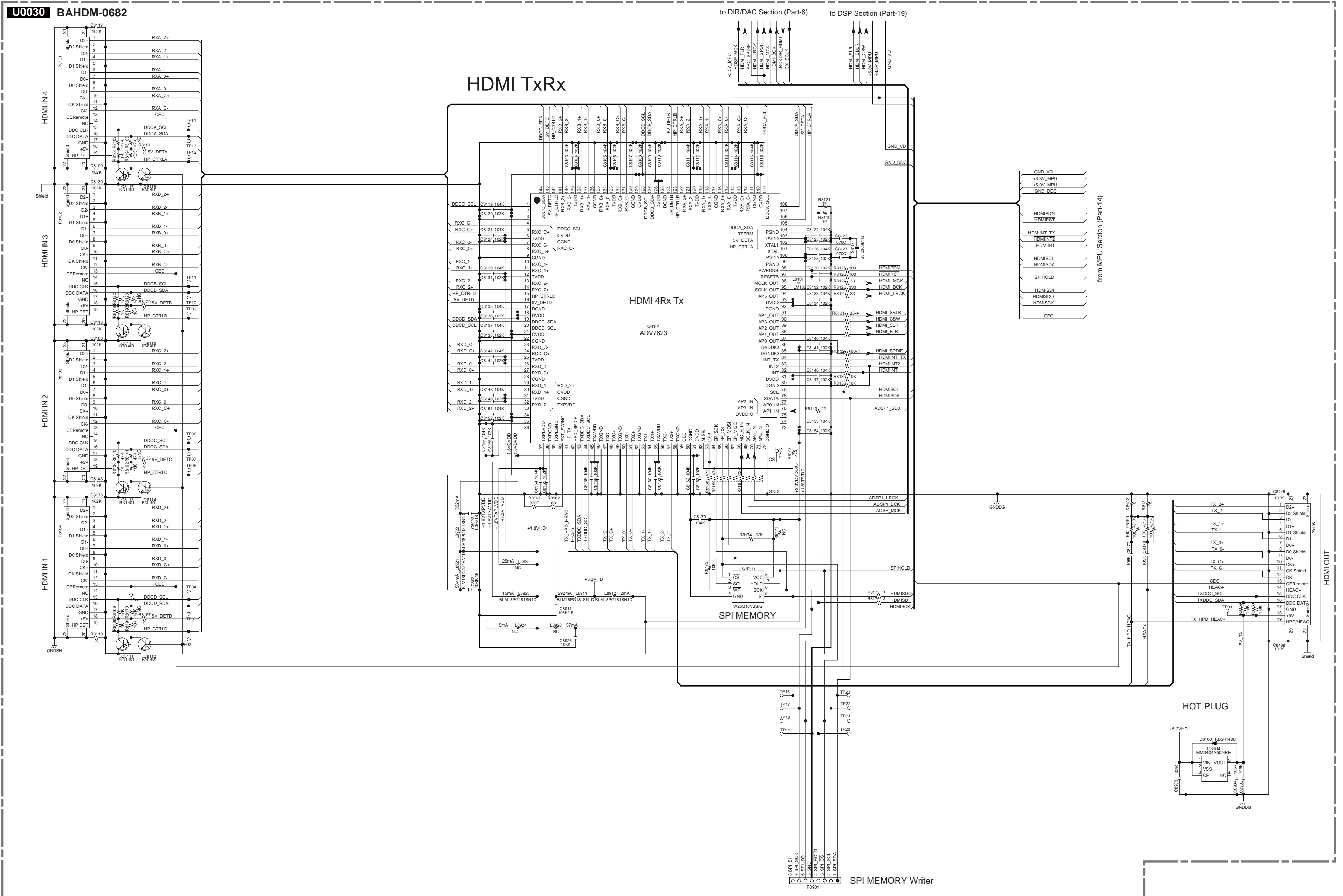

A B C D E F G H I J K
SCHEMATIC DIAGRAM/ BLOCK DIAGRAM-15

HDMI SECTION PART-15

Model No. TX-SR309/ HT-R290/ HT-R390/ HT-R548/ HT-RC330/ HT-R590 Schematic Diagram (Part-15) HDMI Section

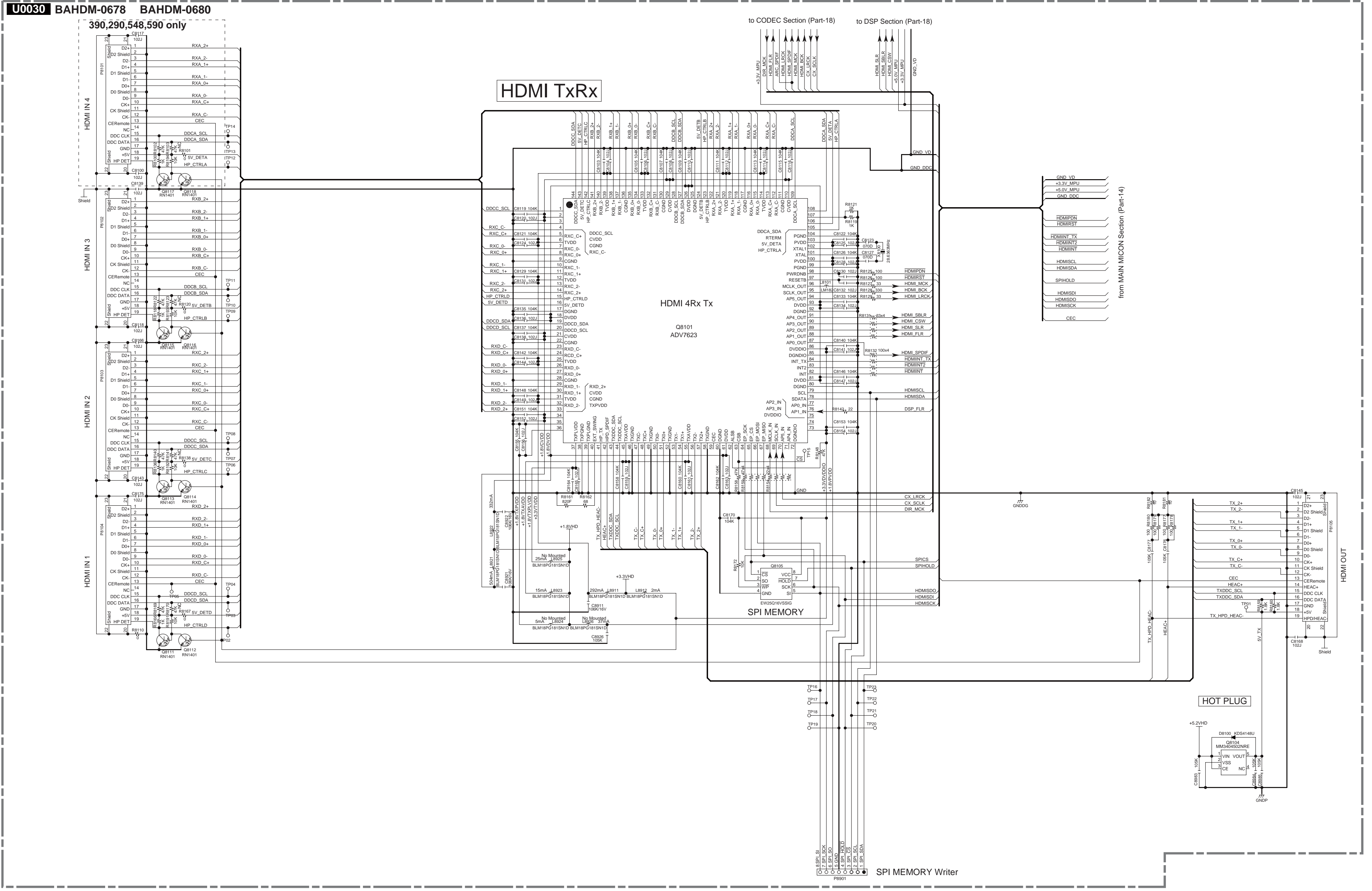

SCHEMATIC DIAGRAM/ BLOCK DIAGRAM-17 VIDEO PROCESSOR SECTION PART-17

U0030 BAHDM-0684

Model No. TX-NR(A)579,TX-NR(A)609,HT-RC360,DTR-20.3,DTR-30.3

SCHEMATIC DIAGRAM (PART-17) VIDEO PROCESSOR SECTION

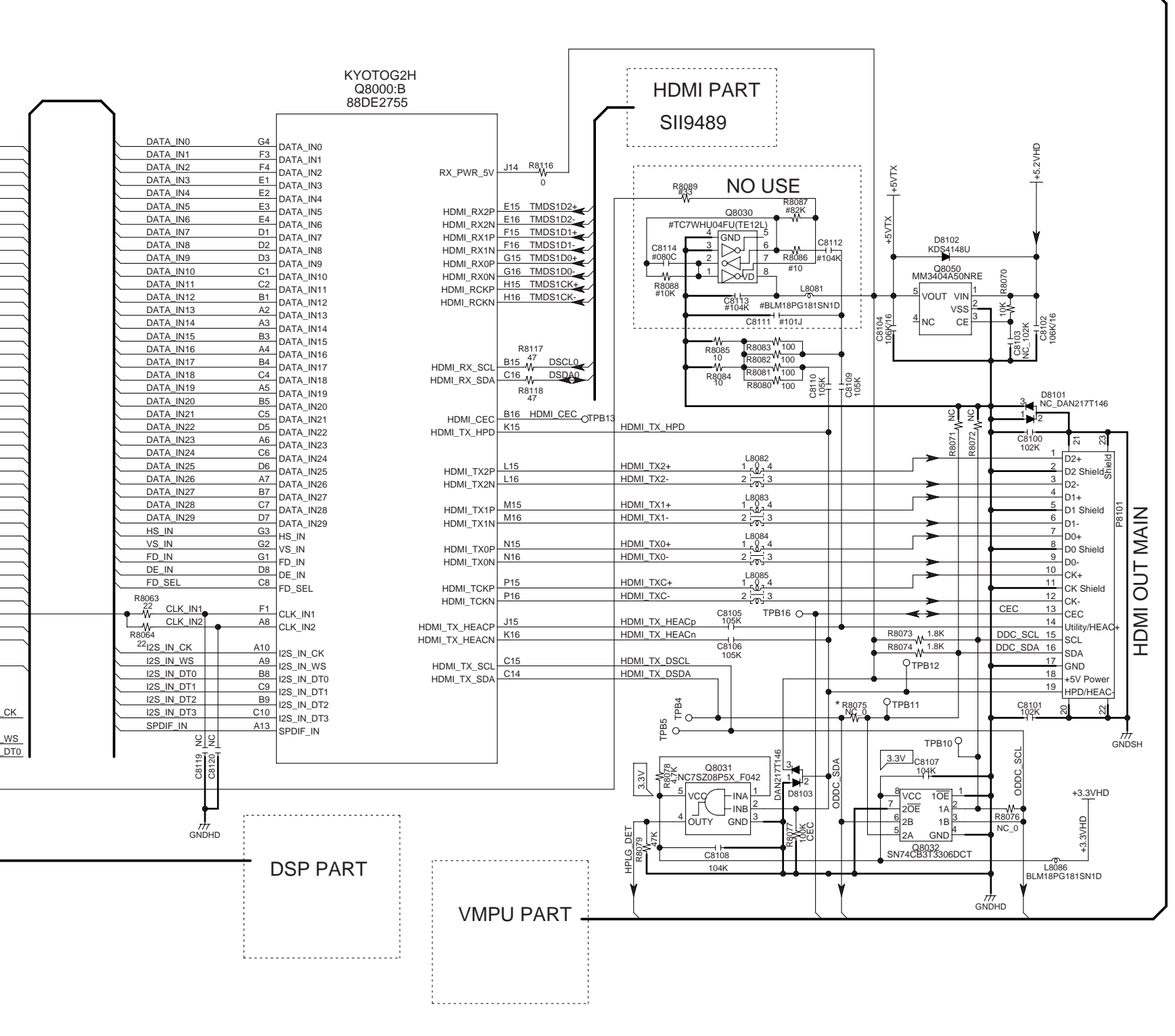
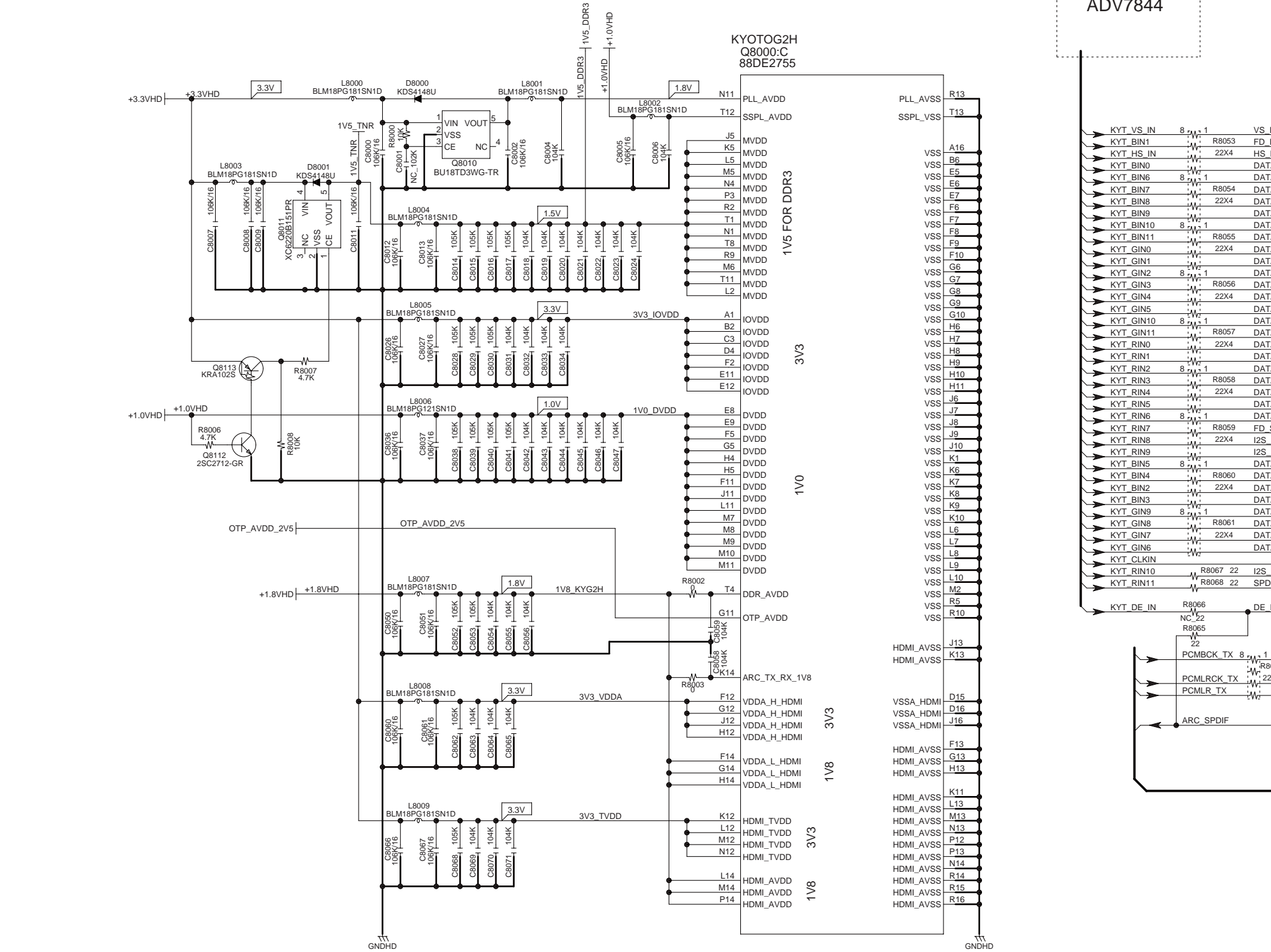
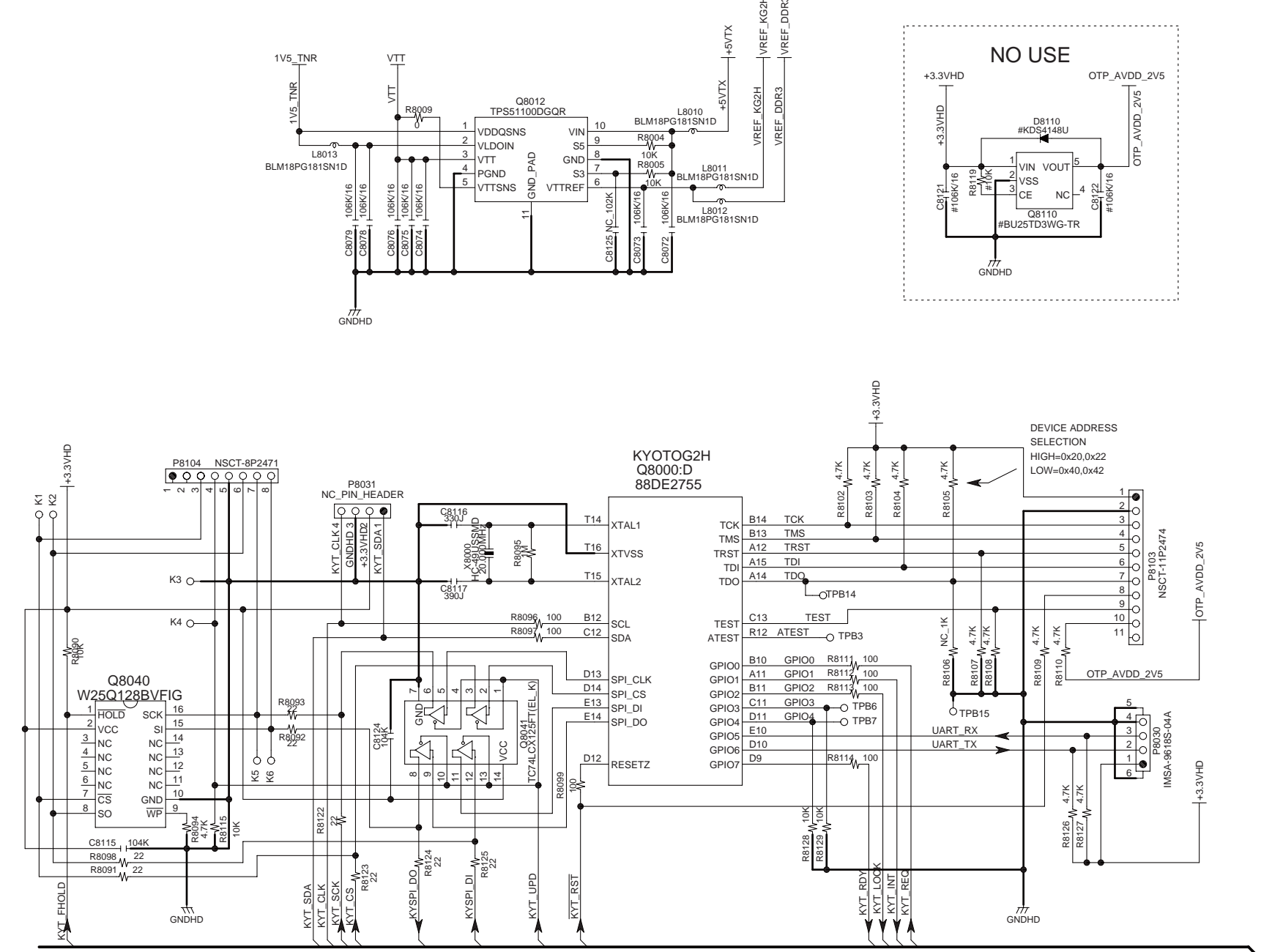
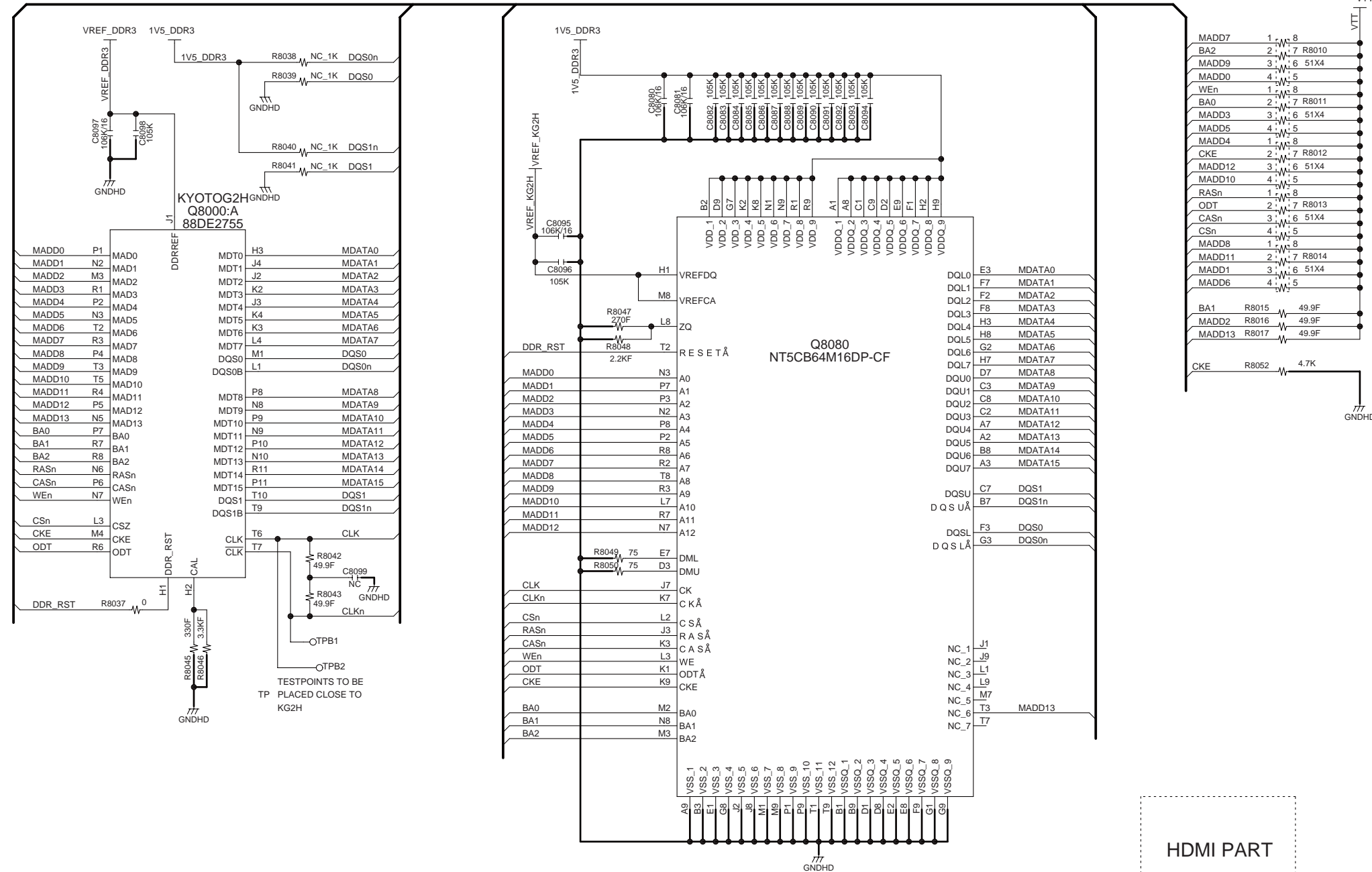

SCHEMATIC DIAGRAM/ BLOCK DIAGRAM-18

DIR/ DAC SECTION

U0040
BAHDM-0040

Model No. TX-NR509/TX-NA509/TX-NA509V SCHEMATIC DIAGRAM (PART-18) DIR/DAC Section

1
2
3
4
5

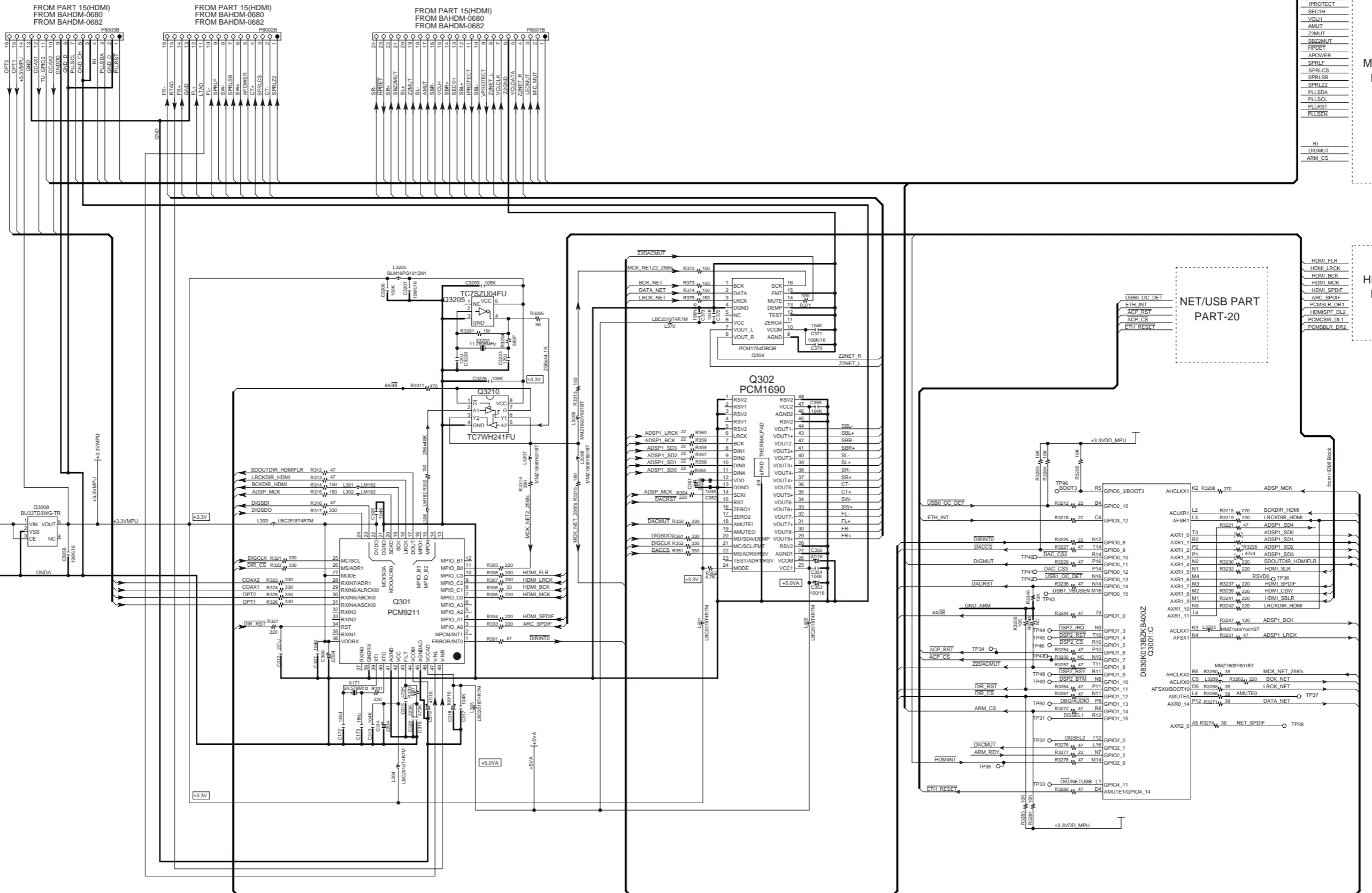

MIC_MUT
LEDMUT
VOLDATA
VOLCLK
VPROTECT
IPROTECT
SECTH
VOLH
AMUT
Z2MUT
SBZ2MUT
RIPDET
APIOWER
SPRLCS
SPRLCS
SPRLCS
SPRLZ2
PLLSDA
PLLSCL
PLLRST
PLLSN
RI
DIGMUT
ARM_CS

MPU PART
PART-14

HDMI_FLR
HDMI_LRCK
HDMI_BCK
HDMI_MCK
HDMI_SPDIF
ARC_SPDIF
PCMISLR_DR1
HDMISPF_DL2
PCMCSW_DL1
PCMISLR_DR2

HDMI PART
PART-15

NET/USB PART
PART-20

GPIO5_3/BOOT3
GPIO2_15
GPIO3_12
GPIO0_8
GPIO0_9
GPIO1_0
GPIO1_1
GPIO1_2
GPIO1_3
GPIO1_4
GPIO1_5
GPIO1_6
GPIO1_7
GPIO1_8
GPIO1_9
GPIO1_10
GPIO1_11
GPIO1_12
GPIO1_13
GPIO1_14
GPIO1_15

AXR1_0
AXR1_1
AXR1_2
AXR1_3
AXR1_4
AXR1_5
AXR1_6
AXR1_7
AXR1_8
AXR1_9
AXR1_10
AXR1_11
AXR2_0

A B C D E F G H

SCHEMATIC DIAGRAM/ BLOCK DIAGRAM-18

DSP AUDIO SECTION PART-18

U0040 BAHDM-0684

DIR/DAC/MPU PART PART-6

Model No. TX-NR(A)579,TX-NR(A)609,HT-RC360,DTR-20.3,DTR-30.3,HT-R690,HT-R990 SCHEMATIC DIAGRAM (Part-18) DSP AUDIO SECTION

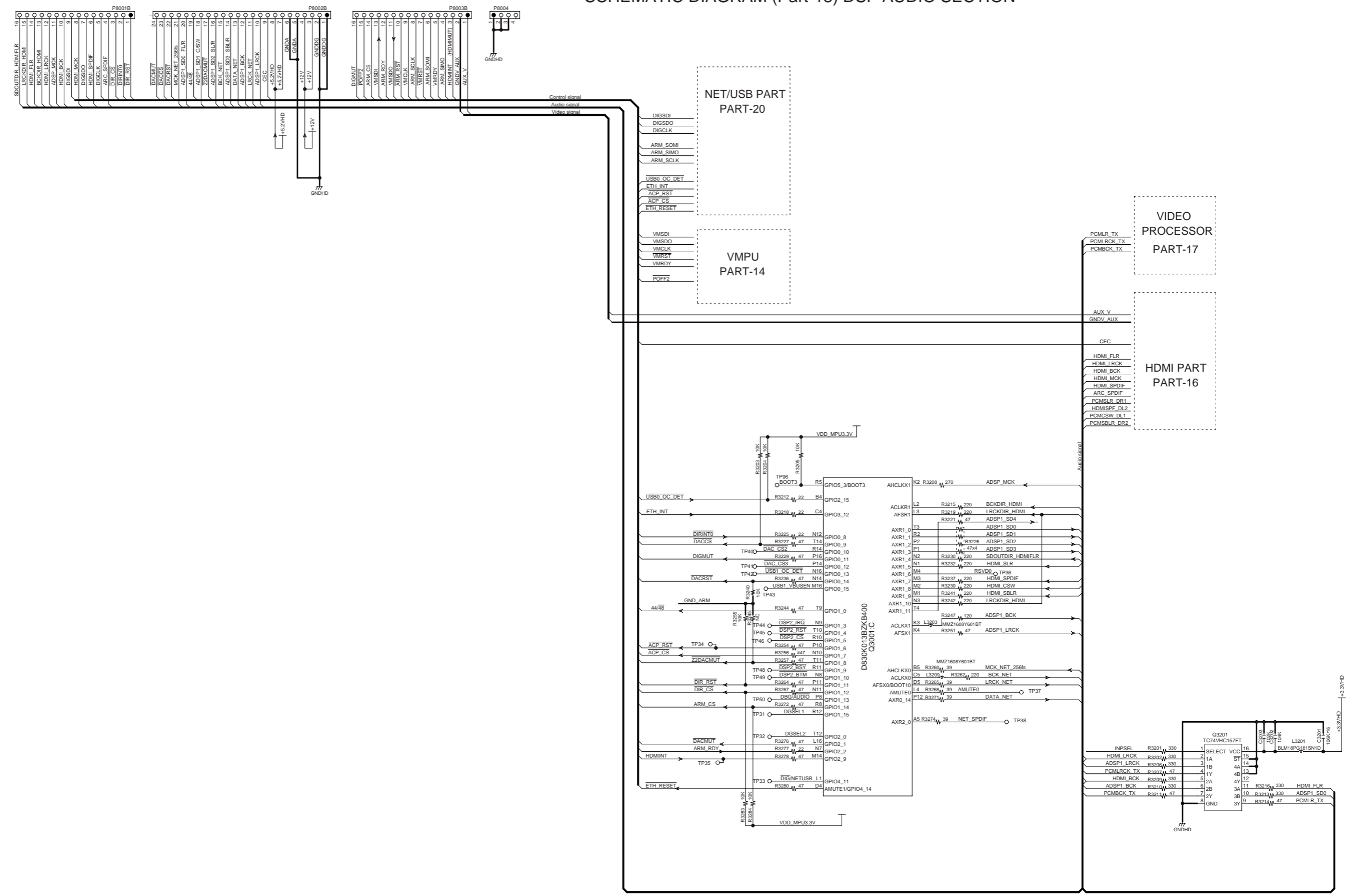

1
2
3
4
5

SCHEMATIC DIAGRAM/ BLOCK DIAGRAM-18

DSP/ CODEC/ DAC SECTION
PART-18

U0040 BAHDM-0680

Model No. HT-R590 Schematic Diagram (Part-18) DSP/CODEC/DAC Section

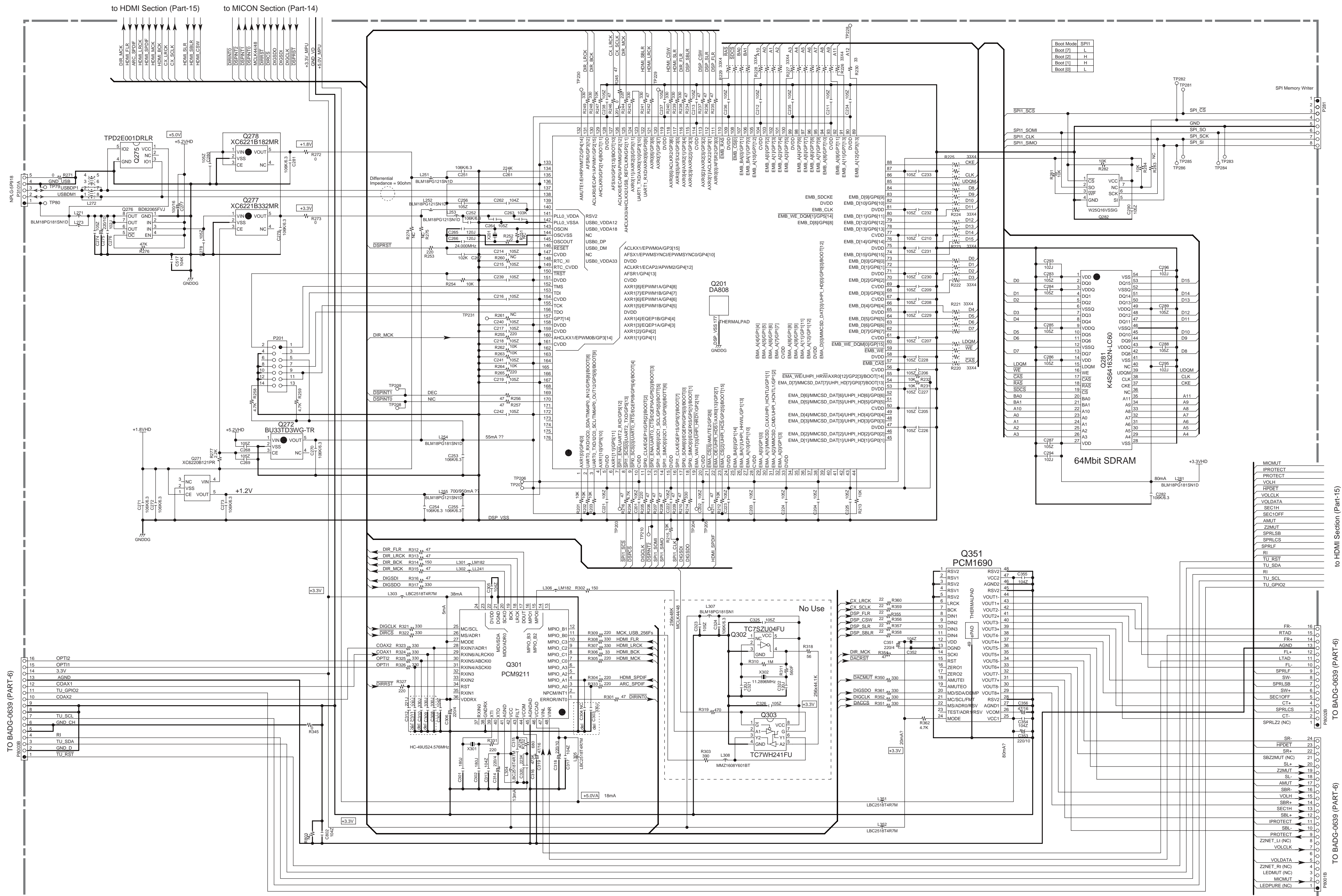

to HDMI Section (Part-15)

TO BADG-0639 (PART-6)

TO BADG-0639 (PART-6)

TO BADG-0639 (PART-6)

8

6

4

3

2

1

SCHEMATIC DIAGRAM/ BLOCK DIAGRAM-18

DSP/ CODEC/ DAC SECTION PART-18

U0030 BAHDM-0678

Model No. TX-SR309 / HT-R290 / HT-R390 / HT-R548 / HT-RC330 Schematic Diagram (Part-18) DSP/CODEC/DAC Section

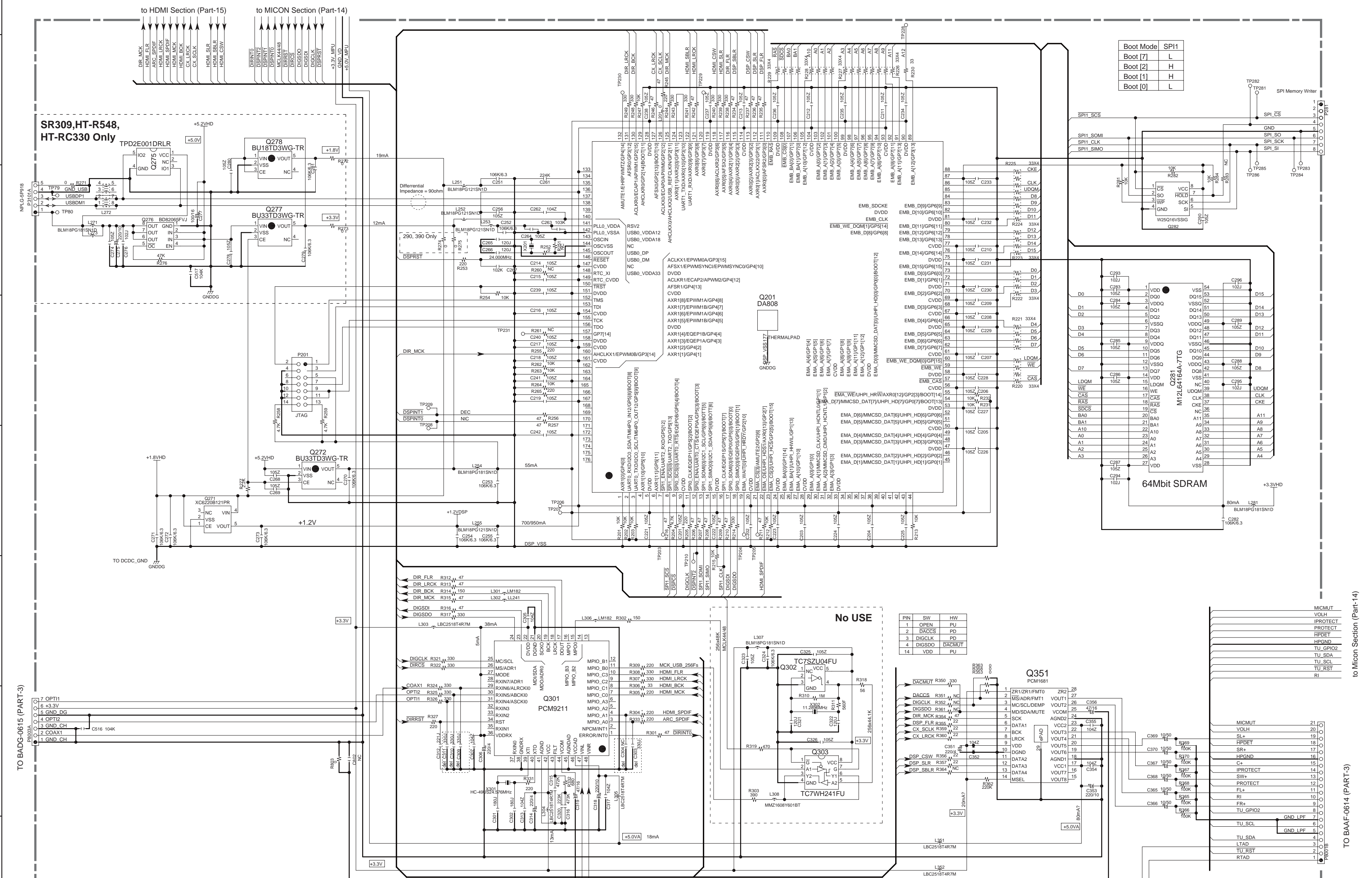

Boot Mode SPI1

Boot [7]	L
Boot [2]	H
Boot [1]	H
Boot [0]	L

64Mbit SDRAM

No USE

PIN	SW	HW
1	OPEN	PU
2	DACCS	PD
3	DIGCLK	PD
4	DIGSDO	DACMUT
14	VDD	PU

to Micon Section (Part-14)

to BAAF-0614 (PART-3)

TO BADG-0615 (PART-3)

8

1
2
3
4
5
6
7

SCHEMATIC DIAGRAM/ BLOCK DIAGRAM-19

1ST DSP MEMORY SECTION PART-19

Model No. TX-NR509/TX-NA509/TX-NA509V SCHEMATIC DIAGRAM (PART-19)
1stDSP Memory Section

1

2

3

4

5

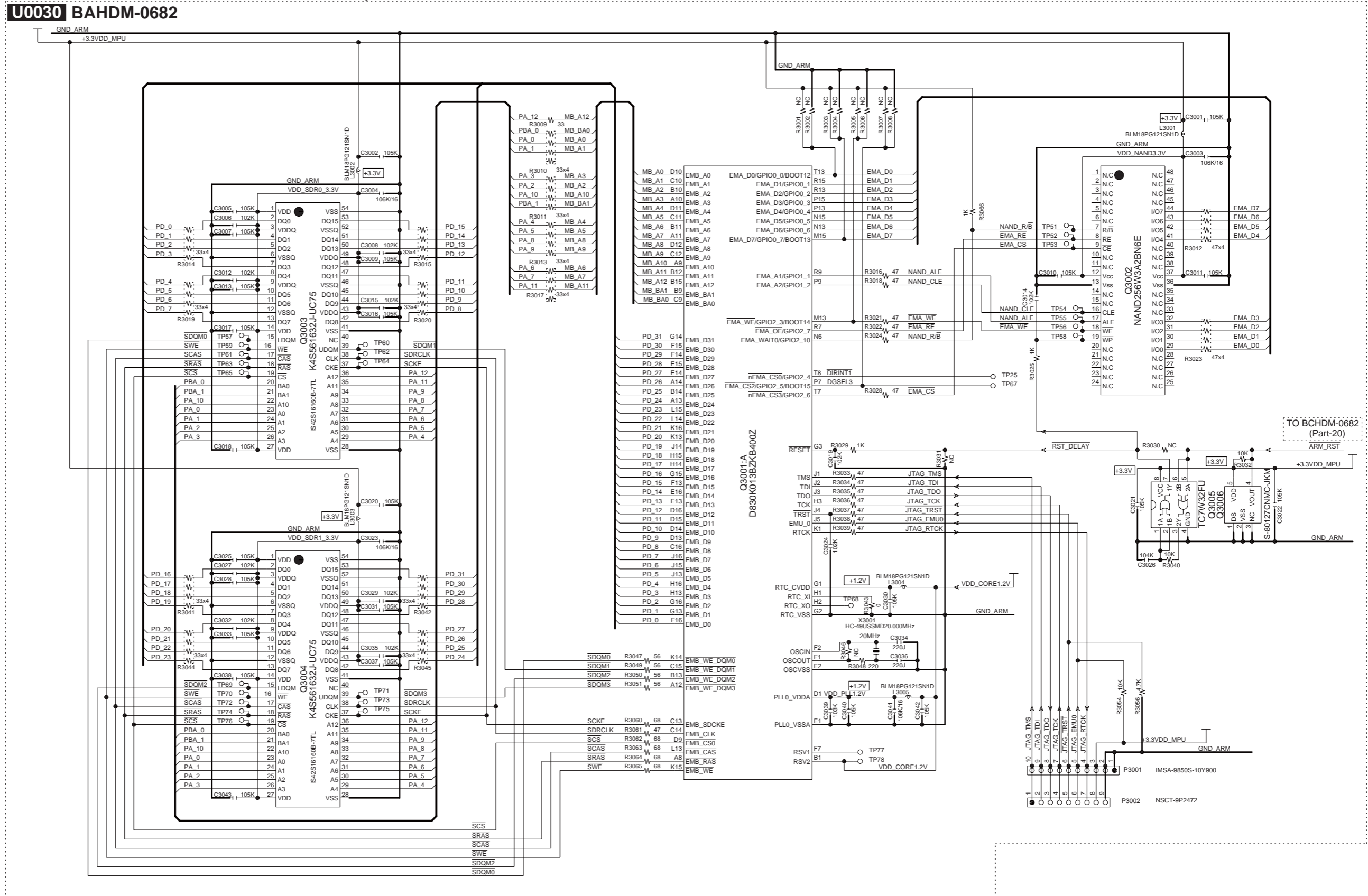

TO BChDM-0682 (Part-20)

SCHEMATIC DIAGRAM/ BLOCK DIAGRAM-19

**DSP MEMORY SECTION
PART-19**

Model No. TX-NR(A)579, TX-NR(A)609, HT-RC360, DTR-20.3, DTR-30.3 SCHEMATIC DIAGRAM (PART-19) DSP Memory Section

U0030 BAHDM-0684

1

2

3

4

5

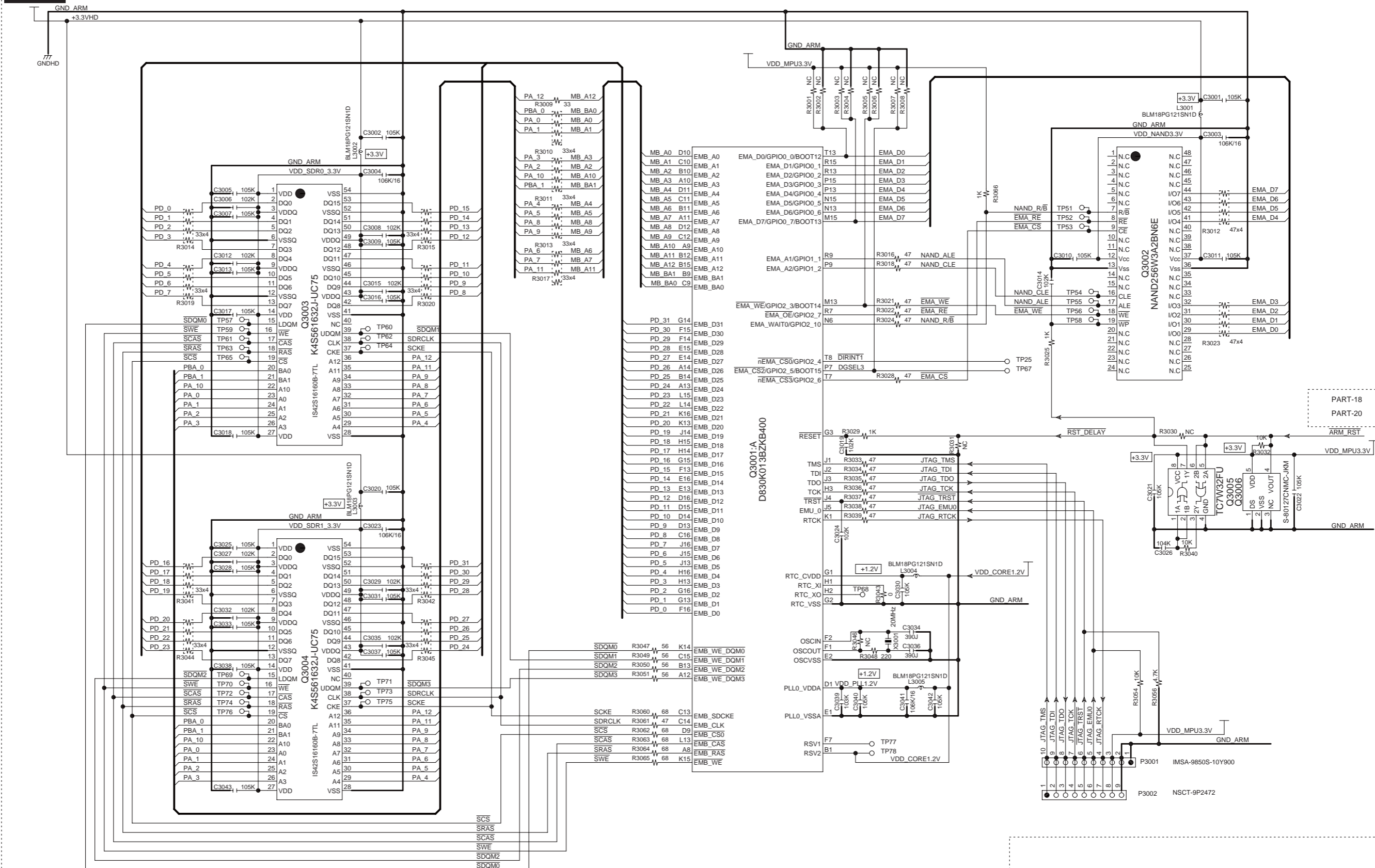

PART-18
PART-20

P3001 IMSA-9850S-10Y900
P3002 NSCT-9P2472

SCHEMATIC DIAGRAM/ BLOCK DIAGRAM-20

Model No. TX-NR509/TX-NA509/TX-NA509V

SCHEMATIC DIAGRAM (PART-20)
NET/USB Power Section

NET/ USB POWER SECTION
PART-20

U0030 BAHDM-0682

R3115 or R3116	BOOT2
R3111 or R3112	BOOT5
R3109 or R3110	BOOT6
R3107 or R3108	BOOT7

Boot Opt.	NAND	UART1	SPI0
BOOT7	L	H	L
BOOT1	H	H	L
BOOT0	H	H	H
BOOT3	H	H	H
BOOT2	H	L	H

BOOT3 is always pulled up.

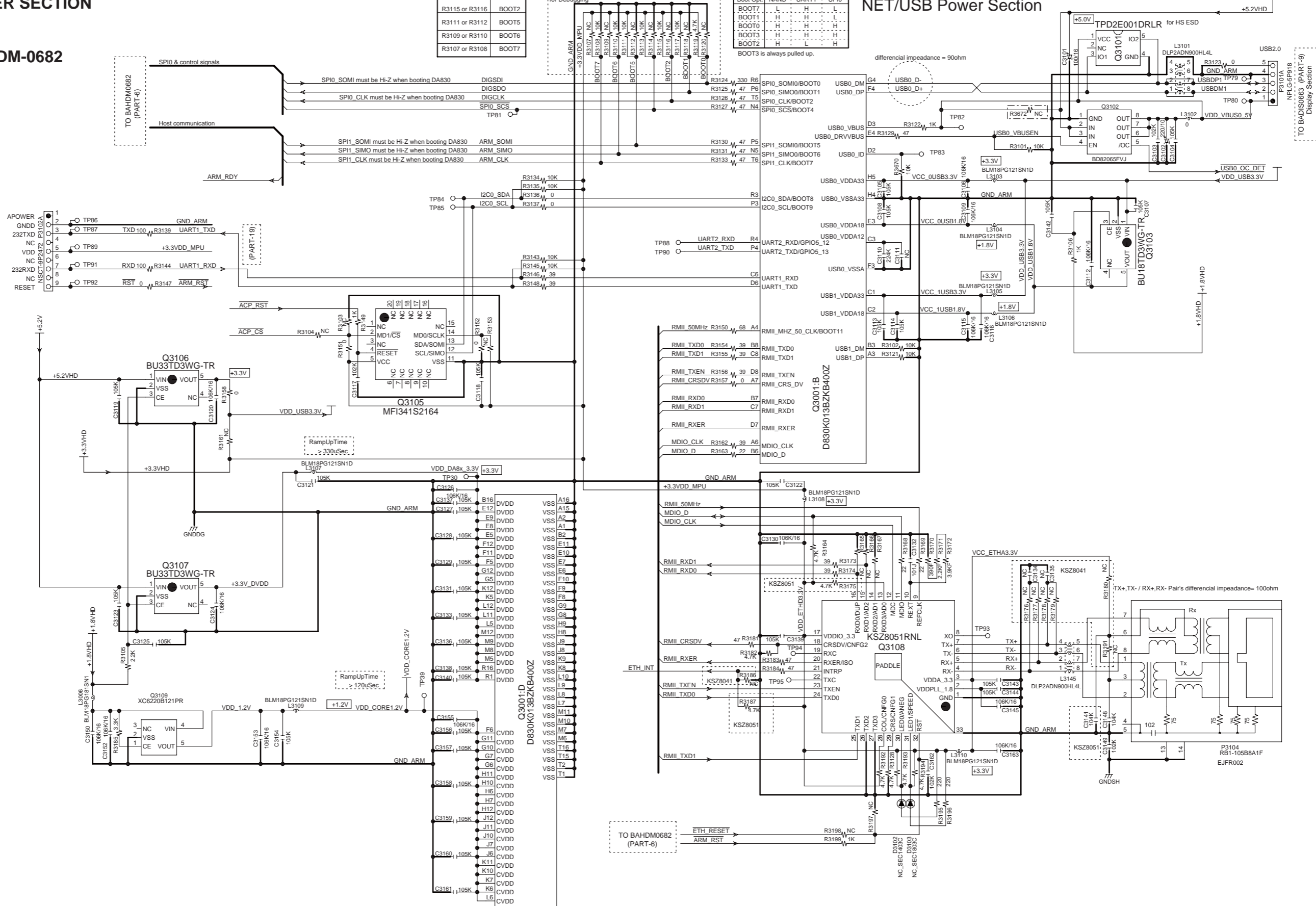

1

2

3

4

5

TO BAHDM0682 (PART-6)

TO BAHDM0682 (PART-6)

TO BAHDM0682 (PART-6)

TO BAHDM0682 (PART-6)

TO BAHDM0682 (PART-6)

TO BAHDM0682 (PART-6)

TO BAHDM0682 (PART-6)

TO BAHDM0682 (PART-6)

TO BAHDM0682 (PART-6)

TO BAHDM0682 (PART-6)

TO BAHDM0682 (PART-6)

TO BAHDM0682 (PART-6)

TO BAHDM0682 (PART-6)

TO BAHDM0682 (PART-6)

TO BAHDM0682 (PART-6)

TO BAHDM0682 (PART-6)

TO BAHDM0682 (PART-6)

TO BAHDM0682 (PART-6)

TO BAHDM0682 (PART-6)

TO BAHDM0682 (PART-6)

TO BAHDM0682 (PART-6)

TO BAHDM0682 (PART-6)

TO BAHDM0682 (PART-6)

TO BAHDM0682 (PART-6)

TO BAHDM0682 (PART-6)

TO BAHDM0682 (PART-6)

TO BAHDM0682 (PART-6)

TO BAHDM0682 (PART-6)

TO BAHDM0682 (PART-6)

TO BAHDM0682 (PART-6)

TO BAHDM0682 (PART-6)

SCHEMATIC DIAGRAM/ BLOCK DIAGRAM-20

NET/ USB POWER SECTION
PART-20

U0030 BAHDM-0684

Model No. TX-NR(A)579, TX-NR(A)609, HT-RC360, DTR-20.3, DTR-30.3

SCHEMATIC DIAGRAM (PART-20)
NET/USB Power Section

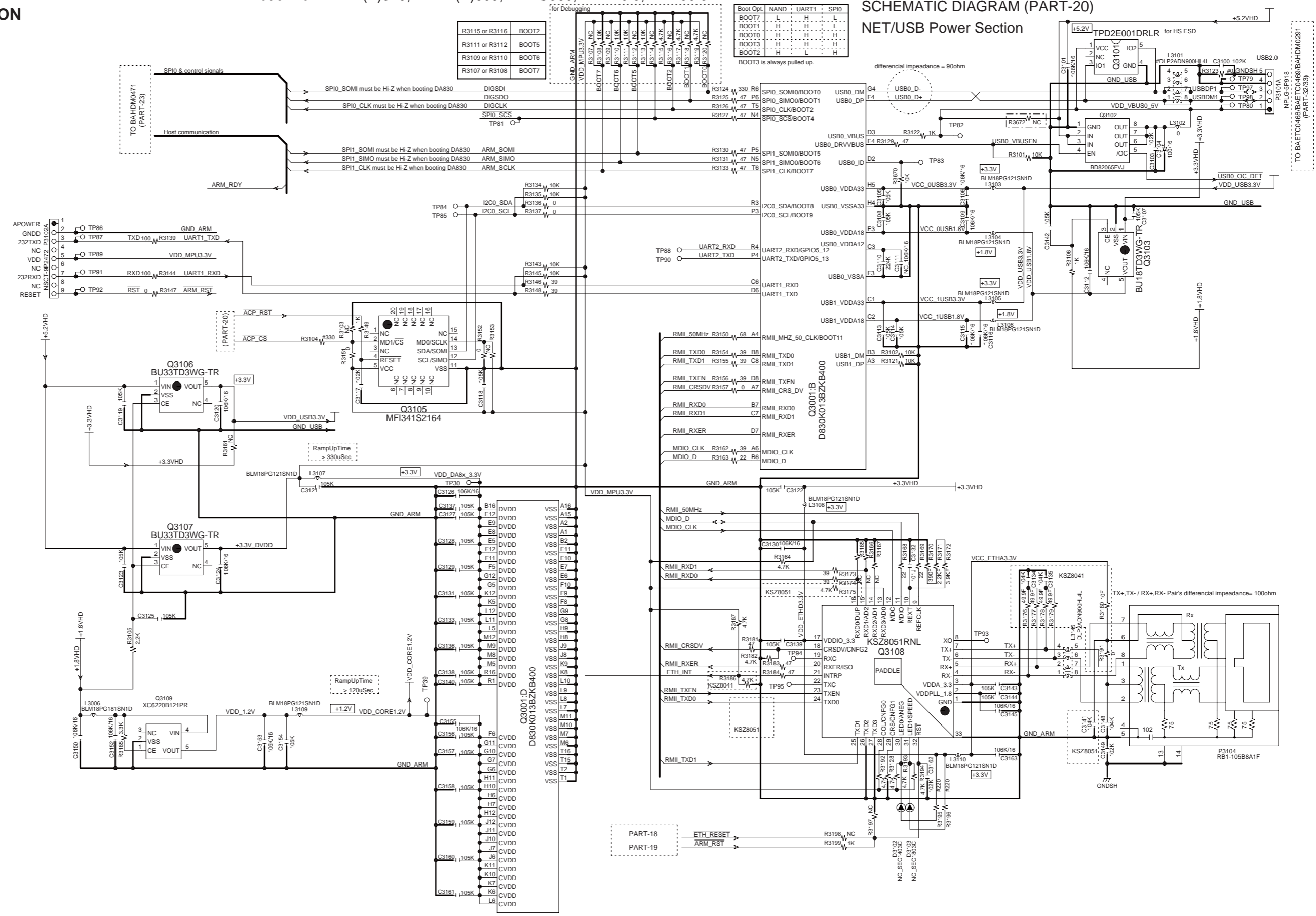

1
2
3
4
5

Boot Opt.	NAND	UART1	SPI0
BOOT7	L	H	L
BOOT1	H	H	L
BOOT0	H	H	H
BOOT3	H	H	H
BOOT2	H	H	H

BOOT3 is always pulled up.

Signal	Component	Value
R3115 or R3116	BOOT2	
R3111 or R3112	BOOT5	
R3109 or R3110	BOOT6	
R3107 or R3108	BOOT7	

TO BAHDM0471 (PART-23)

TO BAETC0468/BAETC0469/BAHDM0291 (PART-32/33)

PART-18
PART-19

ETH RESET
ARM RST

A

B

C

D

SCHEMATIC DIAGRAM/ BLOCK DIAGRAM-21

D-SUB (PC) SECTION

PART-21

1

Model No. TX-NR609/TX-NA609/DTR-20.3/DTR-30.3/HT-R690/HT-R990
Schematic Diagram (PART-21) DSUB(PC) Section

2

U0041 BAETC-0646

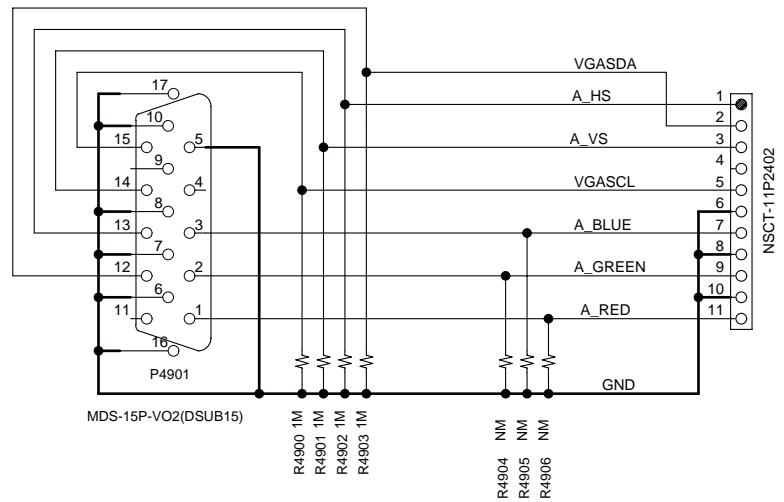

FROM BAHDM-0684(PART-15)

FROM HDMI PWB

3

4

5

HT-R548

<Note>

Parts marked by "NSP" are generally unavailable because they are not in our Master Spare Parts List.

NOTE : THE COMPONENTS IDENTIFIED BY THE MARK
! ARE CRITICAL FOR RISK OF FIRE AND
ELECTRIC SHOCK. REPLACE ONLY WITH PART
NUMBER SPECIFIED.

<Notes>

 : Black model
<S> : Silver model
<MPP> : 230V,CE(European) country model
<MMQ> : 220-240V,Hong kong model

EV EXPLODED VIEW PARTS LIST

EV	REF. NO.	PART NAME	DESCRIPTION	Q'TY	PART NO. (SN)	REMARKS
EV		[CHASSIS SCREW]				
EV	A001	CHASSIS	TX-SR307	1	27100532E	
EV	A003	LEG	(B)	4	27175464	
EV	A005	CUSHION	(ZUL)	4	28141877	
EV	A007	SCREW	3TTB+8B(3BC)	4	838430088GR	
EV	A009	HOLDER	KGLS-8RT	3	27190503A	
EV	A010	HOLDER	KGPS-8RF	1	27191044	
EV	A011	HOLDER	KGLS-10RT	1	27190428A	
EV	A013	HOLDER	KGPS-14RF	2	27190802	
EV	A015	HOLDER	KGPS-14RF	1	27190802	
EV	A017	HOLDER	KGLS-16S	1	27190607	
EV	A019	HOLDER	KGPS-16RF	1	27190991	
EV	A021	HOLDER	KGLS-22S	2	27190369	
EV	A025	SCREW	4TTC+8C(3BC)	4	830440089GR	
EV	A030	HEAT SINK	309P-1	1	27160657	N
EV	A032	RETAINER	(HL)	1	27142159	
EV	A034	RETAINER	(HR)	1	27142223A	
EV	A036	SCREW	3TTB+8B(3BC)	4	838430088GR	
EV	A038	SCREW	3TTB+8B(3BC)	2	838430088GR	
EV	A040	SCREW	3TTB+8B(3BC)	3	838430088GR	
EV	A041	CLIP	CS-1U	1	27255004	
EV	A042	SCREW	3TTB+8B(3BC)	2	838430088GR	
EV	A043	SCREW	3TTB+8B(3CM)SR	1	801637	
EV	A050	SCREW	3SMS8WSW+18B3CM	4	801636	
EV	A054	SCREW	3TTB+8B(3BC)	1	838430088GR	
EV	A055	TAPE	TAPE(CLOTH-8U)	1	29110082	

EV	A056	BUSHING	S-RELIEF #2271	1	27300750	!
EV	A060	WIRE TIE	BSK-1	11	260208	
EV	A101	REAR PANEL	548PP	1	27124228B	N <B MPP / S MPP>
EV	A101	REAR PANEL	548MQ	1	27124229A	N <B MMQ>
EV	A102	CUSHION	---	2	28141799	
EV	A103	SCREW	3P+6FN(3BC)	5	82143006GR	
EV	A105	SCREW	3TTB+8B(3BC)	24	838430088GR	
EV	A112	TAPE	TAPE(CLOTH-16U)	1	29110083	
EV	[CABINET]					
EV	A201	F PANEL	HT-R548(B)PP	1	27213426A	N <B MMQ, MPP>
EV	A201	F PANEL	HT-R548_C(S)PP	1	27213427A	N <S MPP>
EV	A202	CLEAR PLT	TX-SR309 MPP	1	28192335B	<B MMQ, MPP>
EV	A202	CLEAR PLT	TX-SR309(S)MPP	1	28192344B	<S MPP>
EV	A207	BADGE	---	1	28135317	
EV	A211	KNOB	(TONE)(B)	1	28326912	
EV	A211	KNOB	(TONE)(S)	1	28326913	<S>
EV	A213	KNOB	(INP)(B)	1	28326908B	
EV	A213	KNOB	(INP)(S)	1	28326909B	N <S>
EV	A214	KNOB	(INP-LR)(B)	2	28326910B	
EV	A214	KNOB	(INP-LR)(S)	2	28326911B	N <S>
EV	A216	KNOB	(SEL)	1	28326906A	
EV	A217	KNOB	(STBY)(B)	1	28326904	
EV	A217	KNOB	(STBY)(S)	1	28326905	<S>
EV	A219	KNOB	(CUR)	1	28326907B	
EV	A221	IB CUSHION	W15 x 3t TAPE	1	28141585	
EV	A225	SCREW	2.6TTB+8B(3BC)	22	838426088GR	
EV	A255	SCREW	3TTB+8B(3BC)	3	838430088GR	
EV	A256	SCREW	3TTB+8B(3BC)	1	838430088GR	
EV	A260	SCREW	3TTB+8B(3BC)	4	838430088GR	
EV	A268	CUSHION	5 x 20 t=4	1	28141681	
EV	A270	CUSHION	(FELT)t1 x 20 x 10	4	28141859	
EV	A273	HOLDER	KGLS-4S	2	27190009	
EV	A321	KNOB	(VOL)AS(B)	1	28326914	
EV	A321	KNOB	(VOL)AS(S)	1	28326915	N <S>
EV	A340	COVER	(B) (Bent)	1	28210089A	
EV	A340	COVER	(S) (Bent)	1	28210090A	N <S>
EV	A342	SCREW	3TTB+8B(3CM)SR	9	801637	<S>
EV	A342	SCREW	3TTB+8B(3BC)	9	838430088GR	
EV	A350	PLATE	(COVER)B	1	27262881	<B MMQ>

EV	A354	HOLDER	(PLATE)	6	27191337	<B MMQ>
EV	A360	LABEL	(COVER)	1	29390767	
EV	A364	CUSHION	T5 x Φ12 x 6	2	28141867	
EV	[TRANS COIL]					
EV	T901	P TRANS	NPT-1603P	1	2302009	! <MPP>
EV	T901	P TRANS	NPT-1603M	1	2302010	! <MMQ>
EV	[SW TRM]					
EV	F6901	FUSE	8A-T/UL-ST2	1	252261GR	!
EV	F6902	FUSE	8A-T/UL-ST2	1	252261GR	!
EV	F901	FUSE	4A-SE-EAK FUSE	1	252077GR	!
EV	F901 or	FUSE	4A-SE-TL250V	(1)	252277GR	!
EV	F901E	LABEL	T4AL250V	1	29361732A	
EV	P101	FFC	NCFC7-091512	1	2047091512	
EV	P2800	FFC	NCFC5-091012	1	2045091012	
EV	P3101	SOCKET AS	NSAS-10P1924	1	2009991224UL	
EV	P701	FFC	NCFC5-232212	1	2045232212	
EV	P703	FFC	NCFC5-072512	1	2045072512	
EV	P8001	FFC	NCFC5-211012	1	2045211012	
EV	P8002	FFC	NCFC5-091512	1	2045091512	
EV	P901	AC CORD	AS-BS	1	253198LTK	! <MMQ>
EV	P901	AC CORD	AS-CEE-2	1	253306VOL	! <MPP>
EV	P901 or	AC CORD	AS-CEE-2	(1)	253374YUN	! <MPP>
EV	[TUNER UNIT]					
EV	U001	U0010+U0011+U0012+U0013+U0014+U0015+U0016	BAAF-0614-1G *	1	1B258514-1G	N <MPP>
EV	U001		BAAF-0614-1H *	1	1B258514-1H	N <MMQ>
EV	U0010	Power Amp / Audio Input Terminals PC board ass'y	BAAF-0614-1G	1	1B2585614-1G	N <MPP>
EV	U0010		BAAF-0614-1H	1	1B2585614-1H	N <MMQ>
EV	U0011	Digital Input Terminals PC board ass'y	BADG-0615-1G	1	1B2585615-1G	N <MPP>
EV	U0011		BADG-0615-1H	1	1B2585615-1H	N <MMQ>
EV	U0012	Thermal Senser PC board ass'y	BAETC-0616-1G	1	1B2585616-1G	N <MPP>
EV	U0012		BAETC-0616-1H	1	1B2585616-1H	N <MMQ>
EV	U0013	Spacer PC board ass'y	BAETC-0617-1G	1	1B2585617-1G	N <MPP>
EV	U0013		BAETC-0617-1H	1	1B2585617-1H	N <MMQ>
EV	U0014	Terminal PC board ass'y	BAETC-0618-1G	1	1B2585618-1G	N <MPP>
EV	U0014		BAETC-0618-1H	1	1B2585618-1H	N <MMQ>
EV	U0015	FFC Fixture PC board ass'y	BAETC-0619-1G	1	1B2585619-1G	N <MPP>
EV	U0015		BAETC-0619-1H	1	1B2585619-1H	N <MMQ>

EV	U0016	Power supply PC board ass'y	BAETC-0620-1G	1	1B2585620-1G	N <MPP>
EV	U0016		BAETC-0620-1H	1	1B2585620-1H	N <MMQ>
EV	U002	U0020+U0021+U0022+U0023+U0024	BADIS-0654-1D *	1	1B258554-1D	N
EV	U0020	Display PC board ass'y	BADIS-0654-1D	1	1B2585654-1D	N
EV	U0021	Standby switch PC board ass'y	BADIS-0655-1D	1	1B2585655-1D	N
EV	U0022	Video PC board ass'y	BAVD-0656-1D	1	1B2585656-1D	N
EV	U0023	HP Jack PC board ass'y	BAETC-0658-1D	1	1B2585658-1D	N
EV	U0024	Primary Wiring PC board ass'y	BAPS-0659-1D	1	1B2585659-1D	N
EV	U003	U0030 x 2	BAHDM-0678-1F *	1	1B258578-1F	N
EV	U0030	HDMI PC board ass'y	BAHDM-0678-1F	1	1B2585678-1F	N
EV	U010	TUNER UNIT	KST-MW104MS1-S89	1	240172	

PV

HT-R548

PV **PACKING PROCEDURES PARTS LIST**

PV

REF. NO.	PART NAME	DESCRIPTION	Q'TY	PART NO. (SN)	REMARKS	
[PACKING]						
PV	A601	PAD	(AS)HTR390	1	29092582A	
PV	A605	POLY BAG	w850 x d650	1	29100245	
PV	A606	TAPE	(SEROHAN)NITTO NO.29	1	29110149	
PV	A608	SHEET	---	1	29095906	<MPP>
PV	A608	SHEET	T0.5 x 600 x 500	1	29096097	<MMQ>
PV	A611	TAPE	(SEROHAN)NITTO NO.29	1	29110149	
PV	A704A	LABEL	(DES)548BMPP	1	29391483	N <MPP>
PV	A704A	LABEL	(DES)548SMPP	1	29391484	N <MPP>
PV	A704A	LABEL	(DES)548BMMQ	1	29391485	N <MMQ>
[ACCESSARY]						
PV	A672	POLY BAG	w250 x d350	1	29100250A	<MMQ>
PV	A672	POLY BAG	w250 x d350	2	29100250A	<MPP>
PV	A673	POLY BAG	---	1	29100225A	
PV	A674	POLY BAG	D250 x d300 x W300(t0.04)	1	29100256A	
PV	A676	TAPE	(SEROHAN)NITTO NO.29	1	29110149	
PV	A677	TAPE	(SEROHAN)NITTO NO.29	1	29110149	<MPP>
PV	A678	SHEET	(PAD)	1	29096131	
PV	A679	TAPE	(SEROHAN)NITTO NO.29	1	29110149	<B MMQ, MPP>
PV	A680	PP TAPE	W50 SBT-70	1	29110200	
PV	A801	INS MANUAL	En(HTR548)	1	29400608	N
PV	A804	INS MANUAL	FrEs(HTR548)	1	29400610	N <MPP>
PV	A806	INS MANUAL	NISv(HTR548)	1	29400612	N <MPP>

PV	A807	INS MANUAL	Ct(HTR548)	1	29400614	N <MMQ>
PV	A807	INS MANUAL	En(HTP-548)	1	29400632	N <MPP>
PV	A808	INS MANUAL	U8(HTP-770)	1	29400119	<MPP>
PV	A809	INS MANUAL	Ar(HTR548)	1	29400613	N <MMQ>
PV	A810	INS MANUAL	Ar(QC ImportantSheet)	1	29344373B	<MMQ>
PV	A811	INS MANUAL	En-QSS(HTS5405)	1	29400609	N
PV	A812	INS MANUAL	En(HTP-548)	1	29400632	N <MMQ>
PV	A813	INS MANUAL	U8(HTP-770)	1	29400119	<MMQ>
PV	A818	INS MANUAL	ItDe(HTR548)	1	29400611	N <MPP>
PV	A826	INST SHEET	U11(2010_RIHD)	1	29355782	
PV	A830	INST SHEET	WEEE	1	29355793A	<MPP>
PV	A841	INST SHEET	(TX-SR309_USB)	1	29355830	N
PV	A843	INST SHEET	(TX-SR309_HP)	1	29355831	N
PV	A855	REMO CON	RC-799M	1	24140799	
PV	A856	MIC	MIC-7000	1	245044	
PV	A858	ANT COIL	NMA-3057	1	232140	
PV	A859	FM ANT AS	Type W	1	292191	
PV	A861	BATTERY	R6/AA(UM-3)	2	3010194	
PV	A861 or	BATTERY	R6/AA(UM-3)	(2)	3010054	
PV	A884	WRNTY CARD	MGQ	1	29365099A	<MMQ>

HT-R548

U001 PC BOARD PARTS LIST

U001	U001	U0010 + U0011 + U0012 + U0013 + U0014 + U0015 + U0016	
U001	U0010	Power Amp / Audio Input Terminals PC board	BAAF-0614-1G/ 1H
U001	U0011	Digital Input Terminals PC board	BADG-0615-1G/ 1H
U001	U0012	Thermal Senser PC board	BAETC-0616-1G/ 1H
U001	U0013	Spacer PC board	BAETC-0617-1G/ 1H
U001	U0014	Terminal PC board	BAETC-0618--1G/ 1H
U001	U0015	FFC Fixture PC board	BAETC-0619-1G/ 1H
U001	U0016	Power supply PC board	BAETC-0620-1G/ 1H

CIRCUIT NO.	PART NAME	DESCRIPTION	Q'TY	PART NO. (SN)	REMARKS
U001	[SEMI CONDUCTOR]				
U001	D131	C-DIODE	1	223303R2	N
U001	D131 or	C-DIODE	(1)	223283R2	
U001	D132	C-DIODE	1	223303R2	N
U001	D132 or	C-DIODE	(1)	223283R2	

U001	D4171	ZENER D	MTZJ6.8B	1	224470682T	
U001	D4172	ZENER D	MTZJ6.8B	1	224470682T	
U001	D4300	DIODE	RL1N4003	1	22380260T	
U001	D4300 or	DIODE	GP104003E	(1)	22380035T	
U001	D4301	DIODE	RL1N4003	1	22380260T	
U001	D4301 or	DIODE	GP104003E	(1)	22380035T	
U001	D4302	DIODE	RL1N4003	1	22380260T	
U001	D4302 or	DIODE	GP104003E	(1)	22380035T	
U001	D4303	DIODE	RL1N4003	1	22380260T	
U001	D4303 or	DIODE	GP104003E	(1)	22380035T	
U001	D4304	DIODE	ISS133	1	223163T	
U001	D4305	DIODE	ISS133	1	223163T	
U001	D4400	ZENER D	DZ2J056M0L	1	224760560R2	
U001	D4400 or	ZENER D	UDZS5.6B	(1)	224550560R2	
U001	D6020	C-DIODE	DA2J10100	1	223303R2	N
U001	D6020 or	C-DIODE	ISS352	(1)	223234R2	
U001	D6020 or	C-DIODE	ISS355	(1)	223269R2	
U001	D6020 or	C-DIODE	MA2J111	(1)	223279R2	
U001	D6020 or	C-DIODE	KDS4148U	(1)	223283R2	
U001	D6021	C-DIODE	DA2J10100	1	223303R2	N
U001	D6021 or	C-DIODE	ISS352	(1)	223234R2	
U001	D6021 or	C-DIODE	ISS355	(1)	223269R2	
U001	D6021 or	C-DIODE	MA2J111	(1)	223279R2	
U001	D6021 or	C-DIODE	KDS4148U	(1)	223283R2	
U001	D6022	C-DIODE	DA2J10100	1	223303R2	N
U001	D6022 or	C-DIODE	ISS352	(1)	223234R2	
U001	D6022 or	C-DIODE	ISS355	(1)	223269R2	
U001	D6022 or	C-DIODE	MA2J111	(1)	223279R2	
U001	D6022 or	C-DIODE	KDS4148U	(1)	223283R2	
U001	D6023	C-DIODE	DA2J10100	1	223303R2	N
U001	D6023 or	C-DIODE	ISS352	(1)	223234R2	
U001	D6023 or	C-DIODE	ISS355	(1)	223269R2	
U001	D6023 or	C-DIODE	MA2J111	(1)	223279R2	
U001	D6023 or	C-DIODE	KDS4148U	(1)	223283R2	
U001	D6024	C-DIODE	DA2J10100	1	223303R2	N
U001	D6024 or	C-DIODE	ISS352	(1)	223234R2	
U001	D6024 or	C-DIODE	ISS355	(1)	223269R2	
U001	D6024 or	C-DIODE	MA2J111	(1)	223279R2	
U001	D6024 or	C-DIODE	KDS4148U	(1)	223283R2	

U001	D6031	DIODE	ISS133	1	223163T	
U001	D6032	DIODE	ISS133	1	223163T	
U001	D6051	C-DIODE	DA2J10100	1	223303R2	N
U001	D6051 or	C-DIODE	ISS352	(1)	223234R2	
U001	D6051 or	C-DIODE	ISS355	(1)	223269R2	
U001	D6051 or	C-DIODE	MA2J111	(1)	223279R2	
U001	D6051 or	C-DIODE	KDS4148U	(1)	223283R2	
U001	D6052	C-DIODE	DA2J10100	1	223303R2	N
U001	D6052 or	C-DIODE	ISS352	(1)	223234R2	
U001	D6052 or	C-DIODE	ISS355	(1)	223269R2	
U001	D6052 or	C-DIODE	MA2J111	(1)	223279R2	
U001	D6052 or	C-DIODE	KDS4148U	(1)	223283R2	
U001	D6053	C-DIODE	DA2J10100	1	223303R2	N
U001	D6053 or	C-DIODE	ISS352	(1)	223234R2	
U001	D6053 or	C-DIODE	ISS355	(1)	223269R2	
U001	D6053 or	C-DIODE	MA2J111	(1)	223279R2	
U001	D6053 or	C-DIODE	KDS4148U	(1)	223283R2	
U001	D6055	C-DIODE	DA2J10100	1	223303R2	N
U001	D6055 or	C-DIODE	ISS352	(1)	223234R2	
U001	D6055 or	C-DIODE	ISS355	(1)	223269R2	
U001	D6055 or	C-DIODE	MA2J111	(1)	223279R2	
U001	D6055 or	C-DIODE	KDS4148U	(1)	223283R2	
U001	D6704	ZENER D	DZ2J033M0L	1	224760330R2	
U001	D6704 or	ZENER D	UDZS3.3B	(1)	224550330R2	
U001	D6901	DIODE	D5SBA60	1	22380070	
U001	D6901A	HEAT SINK	RAD-083	1	27160271	
U001	D6901C	SCREW	3P+10FN(3BC)	1	82143010GR	
U001	D6902	C-DIODE	DA2J10100	1	223303R2	N
U001	D6902 or	C-DIODE	ISS352	(1)	223234R2	
U001	D6902 or	C-DIODE	ISS355	(1)	223269R2	
U001	D6902 or	C-DIODE	MA2J111	(1)	223279R2	
U001	D6902 or	C-DIODE	KDS4148U	(1)	223283R2	
U001	D6903	C-DIODE	DA2J10100	1	223303R2	N
U001	D6903 or	C-DIODE	ISS352	(1)	223234R2	
U001	D6903 or	C-DIODE	ISS355	(1)	223269R2	
U001	D6903 or	C-DIODE	MA2J111	(1)	223279R2	
U001	D6903 or	C-DIODE	KDS4148U	(1)	223283R2	
U001	D960	DIODE	RL1N4003	1	22380260T	
U001	D961	DIODE	RL1N4003	1	22380260T	

U001	D964	ZENER D	DZ2J360M0L	1	224763600R2
U001	D964 or	ZENER D	UDZS36B	(1)	224553600R2
U001	Q131	IC	TC74HCU04AF	1	222740046R2TO
U001	Q4001	IC	R2A15218FP	1	22242605R3
U001	Q4003	IC	NJM4580M-D	1	22241448R2
U001	Q4100	TR	RN1441	1	2215410R2
U001	Q4101	TR	RN1441	1	2215410R2
U001	Q4102	TR	RN1441	1	2215410R2
U001	Q4103	TR	RN1441	1	2215410R2
U001	Q4104	TR	RN1441	1	2215410R2
U001	Q4107	TR	RN1441	1	2215410R2
U001	Q4117	TR	RN1441	1	2215410R2
U001	Q4130	IC	NJM4580M-D	1	22241448R2
U001	Q4140	IC	NJM4580M-D	1	22241448R2
U001	Q4142	IC	NJM4580M-D	1	22241448R2
U001	Q4143	IC	NJM4580M-D	1	22241448R2
U001	Q4170	IC	78M12HF(NJM78M12FA)	1	222780125JRC
U001	Q4170 or	IC	78M12(AN78M12F)	(1)	222780125MAT
U001	Q4170 or	IC	MPC78M12AHF-AZ	(1)	222780125NEC
U001	Q4170A	HEAT-SINK	HEAT-SINK(RAD-68)	1	27160211
U001	Q4170B	SCREW	3P+10FN(3BC)	1	82143010GR
U001	Q4171	IC	79M12HF(NJM79M12FA)	1	222790125JRC
U001	Q4171 or	IC	79M12F(AN79M12F)	(1)	222790125MAT
U001	Q4171 or	IC	79M12HF(MPC79M12HF)	(1)	222790125NEC
U001	Q4171A	HEAT-SINK	HEAT-SINK(RAD-68)	1	27160211
U001	Q4171B	SCREW	3P+10FN(3BC)	1	82143010GR
U001	Q4400	IC	NJM4580M-D	1	22241448R2
U001	Q4401	TR	2SC2235-Y(TPE6_F)	1	2211654T
U001	Q6001	IC	STK-443-530-E	1	222148
U001	Q6002	IC	STK-442-730-E	1	222150
U001	Q6010	TR	2SC2240-BL(TPE2_F)	1	2211406T
U001	Q6011	TR	2SC2240-BL(TPE2_F)	1	2211406T
U001	Q6012	TR	2SC2240-BL(TPE2_F)	1	2211406T
U001	Q6013	TR	2SC2240-BL(TPE2_F)	1	2211406T
U001	Q6014	TR	2SC2240-BL(TPE2_F)	1	2211406T
U001	Q6021	TR	2SA1163-BL(TE85L_F)	1	2216756R2
U001	Q6022	TR	2SC2240-BL(TPE2_F)	1	2211406T
U001	Q6023	TR	2SC2240-BL(TPE2_F)	1	2211406T
U001	Q6024	TR	2SA1163-BL(TE85L_F)	1	2216756R2

U001	Q6051	TR	KRC105S	1	2217290R2
U001	Q6051 or	TR	RN1405	(1)	2214500R2
U001	Q6051 or	TR	DTC123JKA	(1)	2216690R2
U001	Q6052	TR	KRC105S	1	2217290R2
U001	Q6052 or	TR	RN1405	(1)	2214500R2
U001	Q6052 or	TR	DTC123JKA	(1)	2216690R2
U001	Q6053	TR	KRC105S	1	2217290R2
U001	Q6053 or	TR	RN1405	(1)	2214500R2
U001	Q6053 or	TR	DTC123JKA	(1)	2216690R2
U001	Q6380	IC	LM61CIZ	1	22242212
U001	Q6380A	RETAINER	(PTH)	1	27141884-1
U001	Q6707	TR	KTC3875-GR	1	2216175R2
U001	Q6707 or	TR	2SC2712-GR	(1)	2213145R2
U001	Q6708	TR	KRC105S	1	2217290R2
U001	Q6708 or	TR	RN1405	(1)	2214500R2
U001	Q6708 or	TR	DTC123JKA	(1)	2216690R2
U001	Q960	TR	2SC2235-Y(TPE6_F)	1	2211654T
U001	Q960 or	TR	2SC2235-O(TPE6_F)	(1)	2211653T
U001	[TRANS COIL]				
U001	L131	CHOKE COIL	LBC2518T2R2M	1	231364M022R2
U001	L133	CHOKE COIL	LBC2518T470M	1	231364M470R2
U001	L134	CHOKE COIL	LBC2518T470M	1	231364M470R2
U001	L135	EMIFIL	BK1608HS102-T	1	230955R2
U001	L4001	CHOKE COIL	LBC2518T2R2M	1	231364M022R2
U001	L6000	S COIL	SC-0.8X6.0X29.5T-4RV-C	1	231394AS
U001	L6001	S COIL	SC-0.8X6.0X29.5T-4RV-C	1	231394AS
U001	L6002	S COIL	SC-0.8X6.0X29.5T-4RV-C	1	231394AS
U001	L6003	S COIL	SC-0.8X6.0X29.5T-4RV-C	1	231394AS
U001	L6004	S COIL	SC-0.8X6.0X29.5T-4RV-C	1	231394AS
U001	[CAPACITOR]				
U001	C130	C-CERA C	CK725F1E-104Z1	1	332161040R1
U001	C131	C-CERA C	CC725CH1H-101J1	1	342101014R1
U001	C133	C-CERA C	CK725B1C-104K1	1	332121045R1
U001	C135	C-CERA C	CC725CH1H-080D1	1	342100802R1
U001	C139	UTSP C	CE04W10V-220M(UTSP)	1	397532217T
U001	C140	C-CERA C	CK725F1E-104Z1	1	332161040R1
U001	C141	C-CERA C	CK725F1E-104Z1	1	332161040R1
U001	C142	C-CERA C	CK725F1E-104Z1	1	332161040R1
U001	C143	C-CERA C	CC725CH1H-330J1	1	342103304R1

U001	C144	C-CERA C	CC725CH1H-330J1	1	342103304R1
U001	C145	UTSP C	CE04W10V-220M(UTSP)	1	397532217T
U001	C4003	UPZ C	2AUPZTF221JE	1	376332214T
U001	C4004	UPZ C	2AUPZTF221JE	1	376332214T
U001	C4007	C-CERA C	CC725CH1H-221J1	1	342102214R1
U001	C4008	C-CERA C	CC725CH1H-221J1	1	342102214R1
U001	C4013	C-CERA C	CC725CH1H-221J1	1	342102214R1
U001	C4014	C-CERA C	CC725CH1H-221J1	1	342102214R1
U001	C4017	C-CERA C	CC725CH1H-221J1	1	342102214R1
U001	C4018	C-CERA C	CC725CH1H-221J1	1	342102214R1
U001	C4019	UPZ C	2AUPZTF221JE	1	376332214T
U001	C4020	UPZ C	2AUPZTF221JE	1	376332214T
U001	C4037	C-CERA C	CC725CH1H-221J1	1	342102214R1
U001	C4050	UTSP C	CE04W25V-47M(UTSP)	1	397554707T
U001	C4051	UTSP C	CE04W25V-47M(UTSP)	1	397554707T
U001	C4052	UTSP C	CE04W25V-47M(UTSP)	1	397554707T
U001	C4053	UTSP C	CE04W25V-47M(UTSP)	1	397554707T
U001	C4054	UTSP C	CE04W25V-47M(UTSP)	1	397554707T
U001	C4057	UTSP C	CE04W25V-47M(UTSP)	1	397554707T
U001	C4060	UTSP C	CE04W50V 47M(UTSP)	1	397584707T
U001	C4061	UTSP C	CE04W50V 47M(UTSP)	1	397584707T
U001	C4062	TF C	ECQ-V50V-474J	1	374724744T
U001	C4063	TF C	ECQ-V50V-823J	1	374728234T
U001	C4064	TF C	ECQ-V50V-223J	1	374722234T
U001	C4065	TF C	ECQ-V50V-474J	1	374724744T
U001	C4066	TF C	ECQ-V50V-823J	1	374728234T
U001	C4067	TF C	ECQ-V50V-223J	1	374722234T
U001	C4070	UTSP C	CE04W50V 47M(UTSP)	1	397584707T
U001	C4071	UTSP C	CE04W50V 47M(UTSP)	1	397584707T
U001	C4072	UTSP C	CE04W50V 47M(UTSP)	1	397584707T
U001	C4073	UTSP C	CE04W50V 47M(UTSP)	1	397584707T
U001	C4074	UTSP C	CE04W50V 47M(UTSP)	1	397584707T
U001	C4077	UTSP C	CE04W50V 47M(UTSP)	1	397584707T
U001	C4085	UTSP C	CE04W25V-47M(UTSP)	1	397554707T
U001	C4086	UTSP C	CE04W25V-47M(UTSP)	1	397554707T
U001	C4090	C-CERA C	CC725CH1H-101J1	1	342101014R1
U001	C4091	C-CERA C	CC725CH1H-101J1	1	342101014R1
U001	C4100	UTSP C	CE04W50V 47M(UTSP)	1	397584707T
U001	C4101	UTSP C	CE04W50V 47M(UTSP)	1	397584707T

U001	C4102	UTSP C	CE04W50V 47M(UTSP)	1	397584707T
U001	C4103	UTSP C	CE04W50V 47M(UTSP)	1	397584707T
U001	C4104	UTSP C	CE04W50V 47M(UTSP)	1	397584707T
U001	C4107	UTSP C	CE04W50V 47M(UTSP)	1	397584707T
U001	C4110	UTSP C	CE04W25V-220M(UTSP)	1	397552217T
U001	C4111	UTSP C	CE04W25V-220M(UTSP)	1	397552217T
U001	C4130	UTSP C	CE04W50V 47M(UTSP)	1	397584707T
U001	C4131	C-CERA C	CC725CH1H-221J1	1	342102214R1
U001	C4132	TF C	ECQ-V50V-103J	1	374721034T
U001	C4166	UTSP C	CE04W25V-220M(UTSP)	1	397552217T
U001	C4167	UTSP C	CE04W25V-220M(UTSP)	1	397552217T
U001	C4170	UTSP C	CE04W50V-1M(UTSP)	1	397580107T
U001	C4171	UTSP C	CE04W50V-1M(UTSP)	1	397580107T
U001	C4172	UTSP C	CE04W25V-220M(UTSP)	1	397552217T
U001	C4173	UTSP C	CE04W25V-220M(UTSP)	1	397552217T
U001	C4186	UTSP C	CE04W16V-470M(UTSP)	1	397544717T
U001	C4187	UTSP C	CE04W16V-470M(UTSP)	1	397544717T
U001	C4204	C-CERA C	CC725CH1H-102J1	1	342101024R1
U001	C4205	C-CERA C	CC725CH1H-102J1	1	342101024R1
U001	C4208	C-CERA C	CK725B1H-103K1	1	332101035R1
U001	C4209	UTSP C	CE04W25V-47M(UTSP)	1	397554707T
U001	C4210	UTSP C	CE04W25V-47M(UTSP)	1	397554707T
U001	C4300	TF C	ECQ-V50V-334J	1	374723344T
U001	C4301	VR C	CE04W35V-1000M(VR)	1	394661027S
U001	C4301 or	JAMICON	CE04W35V-1000M	(1)	398561027S
U001	C4302	VR C	CE04W35V-470M(VR)	1	394664717T
U001	C4302 or	JAMICON	CE04W35V-470M	(1)	398564717T
U001	C4402	UTSP C	CE04W25V-47M(UTSP)	1	397554707T
U001	C4403	UTSP C	CE04W25V-47M(UTSP)	1	397554707T
U001	C4404	UTSP C	CE04W25V-47M(UTSP)	1	397554707T
U001	C4405	UTSP C	CE04W25V-47M(UTSP)	1	397554707T
U001	C4406	UTSP C	CE04W25V-47M(UTSP)	1	397554707T
U001	C4407	UTSP C	CE04W25V-47M(UTSP)	1	397554707T
U001	C4408	C-CERA C	CK725F1E-104Z1	1	332161040R1
U001	C4409	C-CERA C	CK725F1E-104Z1	1	332161040R1
U001	C4410	C-CERA C	CC725CH1H-681J1	1	342106814R1
U001	C4411	C-CERA C	CC725CH1H-681J1	1	342106814R1
U001	C4412	C-CERA C	CK725F1A-105Z1	1	332181050R1
U001	C4413	C-CERA C	CK725F1A-105Z1	1	332181050R1

U001	C4414	C-CERA C	CK725F1A-105Z1	1	332181050R1
U001	C4415	C-CERA C	CK725F1A-105Z1	1	332181050R1
U001	C4416	C-CERA C	CC725CH1H-101J1	1	342101014R1
U001	C4417	C-CERA C	CC725CH1H-101J1	1	342101014R1
U001	C4420	MKT C	B32529C0332J289	1	376493324T
U001	C4421	MKT C	B32529C0332J289	1	376493324T
U001	C4422	MKT C	B32529C0332J289	1	376493324T
U001	C4423	MKT C	B32529C0332J289	1	376493324T
U001	C4424	MKT C	B32529C0332J289	1	376493324T
U001	C4427	TF C	ECQ-V50V-333J	1	374723334T
U001	C4430	UPZ C	2AUPZTF151JE	1	376331514T
U001	C4431	UPZ C	2AUPZTF151JE	1	376331514T
U001	C4432	UPZ C	2AUPZTF151JE	1	376331514T
U001	C4433	C-CERA C	CC725CH1H-151J1	1	342101514R1
U001	C4434	C-CERA C	CC725CH1H-151J1	1	342101514R1
U001	C4437	MKT C	B32529C0102J289	1	376491024T
U001	C6009	TF C	ECQ-V50V-333J	1	374723334T
U001	C6010	UTSP C	CE04W50V 47M(UTSP)	1	397584707T
U001	C6011	UTSP C	CE04W50V 47M(UTSP)	1	397584707T
U001	C6012	UTSP C	CE04W50V 47M(UTSP)	1	397584707T
U001	C6013	UTSP C	CE04W50V 47M(UTSP)	1	397584707T
U001	C6014	UTSP C	CE04W50V 47M(UTSP)	1	397584707T
U001	C6020	UPZ C	2AUPZTF471JE	1	376334714T
U001	C6021	UPZ C	2AUPZTF471JE	1	376334714T
U001	C6022	UPZ C	2AUPZTF471JE	1	376334714T
U001	C6023	UPZ C	2AUPZTF471JE	1	376334714T
U001	C6024	UPZ C	2AUPZTF471JE	1	376334714T
U001	C6030	UTSP C	CE04W25V-220M(UTSP)	1	397552217T
U001	C6031	UTSP C	CE04W25V-220M(UTSP)	1	397552217T
U001	C6032	UTSP C	CE04W25V-220M(UTSP)	1	397552217T
U001	C6033	UTSP C	CE04W25V-220M(UTSP)	1	397552217T
U001	C6034	UTSP C	CE04W25V-220M(UTSP)	1	397552217T
U001	C6040	CERA C	CC45CH50V-030D	1	345340302T
U001	C6041	CERA C	CC45CH50V-030D	1	345340302T
U001	C6042	CERA C	CC45CH50V-030D	1	345340302T
U001	C6043	CERA C	CC45CH50V-030D	1	345340302T
U001	C6044	CERA C	CC45CH50V-030D	1	345340302T
U001	C6050	C-CERA C	CK725B1H-472K1	1	332104725R1
U001	C6051	C-CERA C	CK725B1H-472K1	1	332104725R1

U001	C6052	C-CERA C	CK725B1H-472K1	1	332104725R1
U001	C6053	C-CERA C	CK725B1H-472K1	1	332104725R1
U001	C6054	C-CERA C	CK725B1H-472K1	1	332104725R1
U001	C6060	TF C	ECQ-V50V-473J	1	374724734T
U001	C6061	TF C	ECQ-V50V-473J	1	374724734T
U001	C6062	TF C	ECQ-V50V-473J	1	374724734T
U001	C6063	TF C	ECQ-V50V-473J	1	374724734T
U001	C6064	TF C	ECQ-V50V-473J	1	374724734T
U001	C6070	TF C	ECQ-V50V-103J	1	374721034T
U001	C6071	TF C	ECQ-V50V-103J	1	374721034T
U001	C6072	TF C	ECQ-V50V-103J	1	374721034T
U001	C6073	TF C	ECQ-V50V-103J	1	374721034T
U001	C6074	TF C	ECQ-V50V-103J	1	374721034T
U001	C6080	MKT C	B32529C0102J289	1	376491024T
U001	C6081	MKT C	B32529C0102J289	1	376491024T
U001	C6082	MKT C	B32529C0102J289	1	376491024T
U001	C6083	MKT C	B32529C0102J289	1	376491024T
U001	C6084	MKT C	B32529C0102J289	1	376491024T
U001	C6088	MKT C	B32529C0102J289	1	376491024T
U001	C6089	MKT C	B32529C0102J289	1	376491024T
U001	C6090	UTSP C	CE04W25V-100M(UTSP)	1	397551017T
U001	C6091	UTSP C	CE04W50V-1M(UTSP)	1	397580107T
U001	C6092	UTSP C	CE04W50V-1M(UTSP)	1	397580107T
U001	C6093	C-CERA C	CK725F1E-104Z1	1	332161040R1
U001	C6094	C-CERA C	CK725F1E-104Z1	1	332161040R1
U001	C6101	UTSP C	CE04W63V-100M(UTSP)	1	397571017T
U001	C6102	UTSP C	CE04W63V-100M(UTSP)	1	397571017T
U001	C6103	UTSP C	CE04W50V 47M(UTSP)	1	397584707T
U001	C6104	UTSP C	CE04W63V-100M(UTSP)	1	397571017T
U001	C6105	UTSP C	CE04W63V-100M(UTSP)	1	397571017T
U001	C6106	UTSP C	CE04W50V 47M(UTSP)	1	397584707T
U001	C6107	UTSP C	CE04W63V-100M(UTSP)	1	397571017T
U001	C6108	UTSP C	CE04W63V-100M(UTSP)	1	397571017T
U001	C6111	C-CERA C	CC725CH1H-102J1	1	342101024R1
U001	C6112	C-CERA C	CC725CH1H-102J1	1	342101024R1
U001	C6113	C-CERA C	CC725CH1H-102J1	1	342101024R1
U001	C6115	C-CERA C	CC725CH1H-102J1	1	342101024R1
U001	C6630	C-CERA C	CK725F1E-104Z1	1	332161040R1
U001	C6706	UTSP C	CE04W50V-10M(UTSP)	1	397581007T

U001	C6901	ELECT C	CE69W56V-8200MB	1	3504416
U001	C6902	ELECT C	CE69W56V-8200MB	1	3504416
U001	C6911	C-CERA C	CC725CHI1H-102J1	1	342101024R1
U001	C6912	TF C	ECQ-V50V-334J	1	374723344T
U001	C6913	TF C	ECQ-V50V-334J	1	374723344T
U001	C6917	C-CERA C	CC725CHI1H-102J1	1	342101024R1
U001	C950	TF C	ECQ-V50V-104J	1	374721044T
U001	C960	VR C	CE04W63V-220M(VR)	1	394672217T
U001	C960 or	JAMICON	CE04W63V-220M	(1)	398572217T
U001	C961	UTSP C	CE04W50V 47M(UTSP)	1	397584707T
U001	C962	TF C	ECQ-V50V-104J	1	374721044T
U001	C963	UTSP C	CE04W50V 47M(UTSP)	1	397584707T
U001	[RESISTOR]				
U001	R131	C-CARBON R	RN72K1J-750JE	1	435037504R1
U001	R133	C-CARBON R	RN72K1J-100JE	1	435031004R1
U001	R137	C-CARBON R	RN72K1J-103JE	1	435031034R1
U001	R139	C-CARBON R	RN72K1J-823JE	1	435038234R1
U001	R141	C-CARBON R	RN72K1J-470JE	1	435034704R1
U001	R142	C-CARBON R	RN72K1J-470JE	1	435034704R1
U001	R4000	C-CARBON R	RN72K1J-331JE	1	435033314R1
U001	R4001	METAL O R	RS1WBJ-10	1	443621004T
U001	R4003	C-CARBON R	RN72K1J-331JE	1	435033314R1
U001	R4004	C-CARBON R	RN72K1J-331JE	1	435033314R1
U001	R4005	METAL O R	RS1WBJ-15	1	443621504T
U001	R4007	C-CARBON R	RN72K1J-331JE	1	435033314R1
U001	R4008	C-CARBON R	RN72K1J-331JE	1	435033314R1
U001	R4013	C-CARBON R	RN72K1J-331JE	1	435033314R1
U001	R4014	C-CARBON R	RN72K1J-331JE	1	435033314R1
U001	R4015	C-CARBON R	RN72K1J-222JE	1	435032224R1
U001	R4016	C-CARBON R	RN72K1J-222JE	1	435032224R1
U001	R4017	C-CARBON R	RN72K1J-331JE	1	435033314R1
U001	R4018	C-CARBON R	RN72K1J-331JE	1	435033314R1
U001	R4019	C-CARBON R	RN72K1J-331JE	1	435033314R1
U001	R4020	C-CARBON R	RN72K1J-331JE	1	435033314R1
U001	R4023	C-CARBON R	RN72K1J-000JE	1	435030004R1
U001	R4027	C-CARBON R	RN72K1J-223JE	1	435032234R1
U001	R4029	C-CARBON R	RN72K1J-101JE	1	435031014R1
U001	R4043	C-CARBON R	RN72K1J-104JE	1	435031044R1
U001	R4044	C-CARBON R	RN72K1J-104JE	1	435031044R1

U001	R4047	C-CARBON R	RN72K1J-104JE	1	435031044R1
U001	R4048	C-CARBON R	RN72K1J-104JE	1	435031044R1
U001	R4053	C-CARBON R	RN72K1J-104JE	1	435031044R1
U001	R4054	C-CARBON R	RN72K1J-104JE	1	435031044R1
U001	R4055	C-CARBON R	RN72K1J-224JE	1	435032244R1
U001	R4056	C-CARBON R	RN72K1J-224JE	1	435032244R1
U001	R4057	C-CARBON R	RN72K1J-104JE	1	435031044R1
U001	R4058	C-CARBON R	RN72K1J-104JE	1	435031044R1
U001	R4059	C-CARBON R	RN72K1J-104JE	1	435031044R1
U001	R4060	C-CARBON R	RN72K1J-104JE	1	435031044R1
U001	R4067	C-CARBON R	RN72K1J-104JE	1	435031044R1
U001	R4068	C-CARBON R	RN72K1J-104JE	1	435031044R1
U001	R4078	C-CARBON R	RN72K1J-473JE	1	435034734R1
U001	R4079	C-CARBON R	RN72K1J-473JE	1	435034734R1
U001	R4082	C-CARBON R	RN72K1J-104JE	1	435031044R1
U001	R4085	C-CARBON R	RN72K1J-182JE	1	435031824R1
U001	R4086	C-CARBON R	RN72K1J-182JE	1	435031824R1
U001	R4087	C-CARBON R	RN72K1J-222JE	1	435032224R1
U001	R4088	C-CARBON R	RN72K1J-222JE	1	435032224R1
U001	R4089	C-CARBON R	RN72K1J-000JE	1	435030004R1
U001	R4090	C-CARBON R	RN72K1J-123JE	1	435031234R1
U001	R4091	C-CARBON R	RN72K1J-223JE	1	435032234R1
U001	R4092	C-CARBON R	RN72K1J-331JE	1	435033314R1
U001	R4093	C-CARBON R	RN72K1J-332JE	1	435033324R1
U001	R4094	C-CARBON R	RN72K1J-103JE	1	435031034R1
U001	R4095	C-CARBON R	RN72K1J-103JE	1	435031034R1
U001	R4096	C-CARBON R	RN72K1J-331JE	1	435033314R1
U001	R4097	C-CARBON R	RN72K1J-332JE	1	435033324R1
U001	R4098	C-CARBON R	RN72K1J-123JE	1	435031234R1
U001	R4099	C-CARBON R	RN72K1J-223JE	1	435032234R1
U001	R4100	C-CARBON R	RN72K1J-224JE	1	435032244R1
U001	R4101	C-CARBON R	RN72K1J-224JE	1	435032244R1
U001	R4102	C-CARBON R	RN72K1J-224JE	1	435032244R1
U001	R4103	C-CARBON R	RN72K1J-224JE	1	435032244R1
U001	R4104	C-CARBON R	RN72K1J-224JE	1	435032244R1
U001	R4107	C-CARBON R	RN72K1J-224JE	1	435032244R1
U001	R4110	C-CARBON R	RN72K1J-222JE	1	435032224R1
U001	R4111	C-CARBON R	RN72K1J-222JE	1	435032224R1
U001	R4112	C-CARBON R	RN72K1J-222JE	1	435032224R1

U001	R4113	C-CARBON R	RN72K1J-222JE	1	435032224R1
U001	R4114	C-CARBON R	RN72K1J-222JE	1	435032224R1
U001	R4117	C-CARBON R	RN72K1J-271JE	1	435032714R1
U001	R4127	C-CARBON R	RN72K1J-101JE	1	435031014R1
U001	R4130	C-CARBON R	RN72K1J-221JE	1	435032214R1
U001	R4131	C-CARBON R	RN72K1J-473JE	1	435034734R1
U001	R4132	C-CARBON R	RN72K1J-153JE	1	435031534R1
U001	R4133	C-CARBON R	RN72K1J-122JE	1	435031224R1
U001	R4134	C-CARBON R	RN72K1J-103JE	1	435031034R1
U001	R4160	METAL R	RNU1WCJ-0.22	1	453632294T
U001	R4161	METAL R	RNU1WCJ-0.22	1	453632294T
U001	R4166	C-CARBON R	RN72K1J-220JE	1	435032204R1
U001	R4167	C-CARBON R	RN72K1J-220JE	1	435032204R1
U001	R4174	METAL O R	RS1WBJ-68	1	443626804T
U001	R4175	METAL O R	RS1WBJ-68	1	443626804T
U001	R4176	METAL O R	RS1WBJ-15	1	443621504T
U001	R4177	METAL O R	RS1WBJ-15	1	443621504T
U001	R4181	C-CARBON R	RN72K1J-224JE	1	435032244R1
U001	R4189	C-CARBON R	RN72K1J-473JE	1	435034734R1
U001	R4190	C-CARBON R	RN72K1J-473JE	1	435034734R1
U001	R4192	C-CARBON R	RN72K1J-224JE	1	435032244R1
U001	R4193	C-CARBON R	RN72K1J-224JE	1	435032244R1
U001	R4194	C-CARBON R	RN72K1J-224JE	1	435032244R1
U001	R4200	C-CARBON R	RN72K1J-220JE	1	435032204R1
U001	R4201	C-CARBON R	RN72K1J-220JE	1	435032204R1
U001	R4400	C-CARBON R	RN72K1J-223JE	1	435032234R1
U001	R4401	C-CARBON R	RN72K1J-223JE	1	435032234R1
U001	R4402	C-CARBON R	RN72K1J-333JE	1	435033334R1
U001	R4403	C-CARBON R	RN72K1J-333JE	1	435033334R1
U001	R4404	C-CARBON R	RN72K1J-223JE	1	435032234R1
U001	R4405	C-CARBON R	RN72K1J-223JE	1	435032234R1
U001	R4406	C-CARBON R	RN72K1J-273JE	1	435032734R1
U001	R4407	C-CARBON R	RN72K1J-273JE	1	435032734R1
U001	R4408	C-CARBON R	RN72K1J-331JE	1	435033314R1
U001	R4409	C-CARBON R	RN72K1J-331JE	1	435033314R1
U001	R4410	C-CARBON R	RN72K1J-104JE	1	435031044R1
U001	R4411	C-CARBON R	RN72K1J-104JE	1	435031044R1
U001	R4412	C-CARBON R	RN72K1J-220JE	1	435032204R1
U001	R4413	C-CARBON R	RN72K1J-220JE	1	435032204R1

U001	R4414	C-CARBON R	RN72K1J-220JE	1	435032204R1
U001	R4415	C-CARBON R	RN72K1J-220JE	1	435032204R1
U001	R4416	C-CARBON R	RN72K1J-471JE	1	435034714R1
U001	R4417	C-CARBON R	RN72K1J-333JE	1	435033334R1
U001	R4419	C-CARBON R	RN72K1J-000JE	1	435030004R1
U001	R4420	C-CARBON R	RN72K1J-472JE	1	435034724R1
U001	R4421	C-CARBON R	RN72K1J-472JE	1	435034724R1
U001	R4422	C-CARBON R	RN72K1J-472JE	1	435034724R1
U001	R4423	C-CARBON R	RN72K1J-472JE	1	435034724R1
U001	R4424	C-CARBON R	RN72K1J-472JE	1	435034724R1
U001	R4427	C-CARBON R	RN72K1J-472JE	1	435034724R1
U001	R4430	C-CARBON R	RN72K1J-153JE	1	435031534R1
U001	R4431	C-CARBON R	RN72K1J-153JE	1	435031534R1
U001	R4432	C-CARBON R	RN72K1J-153JE	1	435031534R1
U001	R4433	C-CARBON R	RN72K1J-153JE	1	435031534R1
U001	R4434	C-CARBON R	RN72K1J-153JE	1	435031534R1
U001	R4437	C-CARBON R	RN72K1J-153JE	1	435031534R1
U001	R4440	C-CARBON R	RN72K1J-331JE	1	435033314R1
U001	R4441	C-CARBON R	RN72K1J-331JE	1	435033314R1
U001	R4442	C-CARBON R	RN72K1J-331JE	1	435033314R1
U001	R4443	C-CARBON R	RN72K1J-331JE	1	435033314R1
U001	R4444	C-CARBON R	RN72K1J-331JE	1	435033314R1
U001	R4447	C-CARBON R	RN72K1J-331JE	1	435033314R1
U001	R4450	C-CARBON R	RN72K1J-561JE	1	435035614R1
U001	R4451	C-CARBON R	RN72K1J-561JE	1	435035614R1
U001	R4452	C-CARBON R	RN72K1J-561JE	1	435035614R1
U001	R4453	C-CARBON R	RN72K1J-561JE	1	435035614R1
U001	R4454	C-CARBON R	RN72K1J-561JE	1	435035614R1
U001	R4457	C-CARBON R	RN72K1J-561JE	1	435035614R1
U001	R4601	C-CARBON R	RN72K1J-471JE	1	435034714R1
U001	R4602	C-CARBON R	RN72K1J-000JE	1	435030004R1
U001	R6010	C-CARBON R	RN72K1J-102JE	1	435031024R1
U001	R6011	C-CARBON R	RN72K1J-102JE	1	435031024R1
U001	R6012	C-CARBON R	RN72K1J-102JE	1	435031024R1
U001	R6013	C-CARBON R	RN72K1J-102JE	1	435031024R1
U001	R6014	C-CARBON R	RN72K1J-102JE	1	435031024R1
U001	R6020	CARBON R	R16J-56K	1	417345634T
U001	R6021	CARBON R	R16J-56K	1	417345634T
U001	R6022	CARBON R	R16J-56K	1	417345634T

U001	R6023	CARBON R	R16J-56K	1	417345634T
U001	R6024	CARBON R	R16J-56K	1	417345634T
U001	R6030	CARBON R	R16J-2.2K	1	417342224T
U001	R6031	CARBON R	R16J-2.2K	1	417342224T
U001	R6032	CARBON R	R16J-2.2K	1	417342224T
U001	R6033	CARBON R	R16J-2.2K	1	417342224T
U001	R6034	CARBON R	R16J-2.2K	1	417342224T
U001	R6040	CARBON R	R16J-120K	1	417341244T
U001	R6041	CARBON R	R16J-120K	1	417341244T
U001	R6042	CARBON R	R16J-120K	1	417341244T
U001	R6043	CARBON R	R16J-120K	1	417341244T
U001	R6044	CARBON R	R16J-120K	1	417341244T
U001	R6050	CARBON R	R16J-120K	1	417341244T
U001	R6051	CARBON R	R16J-120K	1	417341244T
U001	R6052	CARBON R	R16J-120K	1	417341244T
U001	R6053	CARBON R	R16J-120K	1	417341244T
U001	R6054	CARBON R	R16J-120K	1	417341244T
U001	R6070	C-CARBON R	RN72K1J-563JE	1	435035634R1
U001	R6071	C-CARBON R	RN72K1J-563JE	1	435035634R1
U001	R6072	C-CARBON R	RN72K1J-563JE	1	435035634R1
U001	R6073	C-CARBON R	RN72K1J-563JE	1	435035634R1
U001	R6074	C-CARBON R	RN72K1J-563JE	1	435035634R1
U001	R6080	C-CARBON R	RN72K1J-123JE	1	435031234R1
U001	R6081	C-CARBON R	RN72K1J-123JE	1	435031234R1
U001	R6082	C-CARBON R	RN72K1J-123JE	1	435031234R1
U001	R6083	C-CARBON R	RN72K1J-123JE	1	435031234R1
U001	R6084	C-CARBON R	RN72K1J-123JE	1	435031234R1
U001	R6100	C-CARBON R	RN72K1J-333JE	1	435033334R1
U001	R6101	C-CARBON R	RN72K1J-333JE	1	435033334R1
U001	R6102	C-CARBON R	RN72K1J-333JE	1	435033334R1
U001	R6103	C-CARBON R	RN72K1J-333JE	1	435033334R1
U001	R6104	C-CARBON R	RN72K1J-333JE	1	435033334R1
U001	R6110	C-CARBON R	RN72K1J-473JE	1	435034734R1
U001	R6111	C-CARBON R	RN72K1J-473JE	1	435034734R1
U001	R6112	C-CARBON R	RN72K1J-473JE	1	435034734R1
U001	R6113	C-CARBON R	RN72K1J-473JE	1	435034734R1
U001	R6114	C-CARBON R	RN72K1J-473JE	1	435034734R1
U001	R6120	C-CARBON R	RN72K1J-473JE	1	435034734R1
U001	R6121	C-CARBON R	RN72K1J-473JE	1	435034734R1

U001	R6122	C-CARBON R	RN72K1J-473JE	1	435034734R1	
U001	R6123	C-CARBON R	RN72K1J-473JE	1	435034734R1	
U001	R6124	C-CARBON R	RN72K1J-473JE	1	435034734R1	
U001	R6130	C-CARBON R	RN72K2E-150JE	1	435221504R1	
U001	R6131	C-CARBON R	RN72K2E-150JE	1	435221504R1	
U001	R6132	C-CARBON R	RN72K2E-150JE	1	435221504R1	
U001	R6133	C-CARBON R	RN72K2E-150JE	1	435221504R1	
U001	R6134	C-CARBON R	RN72K2E-150JE	1	435221504R1	
U001	R6140	METAL R	RNU1WCJ-8.2	1	453630824T	
U001	R6141	METAL R	RNU1WCJ-8.2	1	453630824T	
U001	R6142	METAL R	RNU1WCJ-8.2	1	453630824T	
U001	R6143	METAL R	RNU1WCJ-8.2	1	453630824T	
U001	R6144	METAL R	RNU1WCJ-8.2	1	453630824T	
U001	R6160	METAL O R	RS2WBJ-0.22	1	442722294T	N
U001	R6161	METAL O R	RS2WBJ-0.22	1	442722294T	N
U001	R6162	METAL O R	RS2WBJ-0.22	1	442722294T	N
U001	R6163	METAL O R	RS2WBJ-0.22	1	442722294T	N
U001	R6164	METAL O R	RS2WBJ-0.22	1	442722294T	N
U001	R6170	METAL O R	RS2WBJ-0.22	1	442722294T	N
U001	R6171	METAL O R	RS2WBJ-0.22	1	442722294T	N
U001	R6172	METAL O R	RS2WBJ-0.22	1	442722294T	N
U001	R6173	METAL O R	RS2WBJ-0.22	1	442722294T	N
U001	R6174	METAL O R	RS2WBJ-0.22	1	442722294T	N
U001	R6203	CARBON R	R16J-33K	1	417343334T	
U001	R6204	METAL O R	RS1/2WBJ-100	1	443521014T	
U001	R6205	METAL O R	RS1/2WBJ-100	1	443521014T	
U001	R6208	METAL O R	RS1/2WBJ-56K	1	443525634T	
U001	R6209	METAL O R	RS1/2WBJ-100	1	443521014T	
U001	R6210	METAL O R	RS1/2WBJ-100	1	443521014T	
U001	R6211	C-CARBON R	RN72K1J-333JE	1	435033334R1	
U001	R6213	C-CARBON R	RN72K1J-103JE	1	435031034R1	
U001	R6214	C-CARBON R	RN72K1J-473JE	1	435034734R1	
U001	R6216	C-CARBON R	RN72K1J-223JE	1	435032234R1	
U001	R6217	C-CARBON R	RN72K1J-473JE	1	435034734R1	
U001	R6218	C-CARBON R	RN72K1J-103JE	1	435031034R1	
U001	R6219	C-CARBON R	RN72K1J-223JE	1	435032234R1	
U001	R6230	C-CARBON R	RN72K2E-150JE	1	435221504R1	
U001	R6231	C-CARBON R	RN72K2E-150JE	1	435221504R1	
U001	R6232	C-CARBON R	RN72K2E-150JE	1	435221504R1	

U001	R6233	C-CARBON R	RN72K2E-150JE	1	435221504R1	
U001	R6234	C-CARBON R	RN72K2E-150JE	1	435221504R1	
U001	R6251	METAL O R	RS1/2WBJ-390	1	443523914T	
U001	R6252	METAL O R	RS1/2WBJ-390	1	443523914T	
U001	R6709	C-CARBON R	RN72K1J-562JE	1	435035624R1	
U001	R6710	C-CARBON R	RN72K1J-562JE	1	435035624R1	
U001	R6902	C-CARBON R	RN72K1J-102JE	1	435031024R1	
U001	R6903	C-CARBON R	RN72K1J-473JE	1	435034734R1	
U001	R6912	METAL R	RNU1/2WCJ-0.1	1	453531094T	
U001	R950	METAL O R	RS1WBJ-10	1	443621004T	
U001	R960	METAL R	RNU1/2WCJ-8.2	1	453530824T	
U001	R961	CARBON R	R16J-3.3	1	417340334T	
U001	R962	C-CARBON R	RN72K1J-822JE	1	435038224R1	
U001	R963	C-CARBON R	RN72K1J-822JE	1	435038224R1	
U001	R964	C-CARBON R	RN72K1J-333JE	1	435033334R1	
U001	[SW TRM]					
U001	E6001	RETAINER	MET37-0002	1	27142009T	
U001	F6901A	FUSE HOL	NSCT-1P2031	1	25052133T	!
U001	F6901B	FUSE HOL	NSCT-1P2031	1	25052133T	!
U001	F6902A	FUSE HOL	NSCT-1P2031	1	25052133T	!
U001	F6902B	FUSE HOL	NSCT-1P2031	1	25052133T	!
U001	JL501A	WIRE HOL	NSCT-3P874	1	25051087	
U001	JL600A	WIRE HOL	NSCT-7P898	1	25051111	
U001	JL600B	WIRE HOL	NSCT-7P898	1	25051111	
U001	JL603A	WIRE HOL	NSCT-9P900	1	25051113	
U001	JL603B	WIRE HOL	NSCT-9P900	1	25051113	
U001	JL605B	SOCKET	NSCT-5P97	1	25050269	
U001	JL951A	WIRE HOL	NSCT-5P896	1	25051109	
U001	JL951B	WIRE HOL	NSCT-5P896	1	25051109	
U001	JL952A	WIRE HOL	NSCT-3P894	1	25051107	
U001	JL953B	WIRE TRAP	NPLG-5P588	1	25055626	
U001	JL954A	WIRE HOL	NSCT-9P900	1	25051113	
U001	JL954B	WIRE HOL	NSCT-9P900	1	25051113	
U001	P101B	SOCKET	NSCT-9P2102	1	25052205	
U001	P131	PIN JACK	NPJ-1PDO554	1	25045772	
U001	P4000	ST JACK	MSJ-035-22	1	25045887	
U001	P4000 or	JACK	YKB21-5130	(1)	25045387	
U001	P4002	PIN JACK	NPJ-4PDWR690	1	25045922	
U001	P4005	PIN JACK	NPJ-4PDWWR624	1	25045845	

U001	P4006	PIN JACK	NPJ-4PDWRR624	1	25045845
U001	P4009	PIN JACK	NPJ-1PDP555	1	25045773
U001	P6001	TRM	NTM-10PDML363	1	25060434
U001	P6001 or	TRM	NTM-10PDML354	(1)	25060425
U001	P6002	TRM	NTM-4PDML364	1	25060435
U001	P6900	CRIMP AS	CRIMP AS	1	20799162UL
U001	P6901	CRIMP AS	CRIMP AS	1	2069925162UL
U001	P6902	CRIMP AS	CRIMP AS	1	2069925169UL
U001	P6903	WS CLAMP	CB-71683(L=50)	1	260261
U001	P6906	WS CLAMP	CB-71683(L=50)	1	260261
U001	P6909	WS CLAMP	CB-71683(L=50)	1	260261
U001	P6913	WS CLAMP	CB-71683(L=50)	1	260261
U001	P6915	WS CLAMP	CB-71683(L=50)	1	260261
U001	P703B	SOCKET	NSCT-7P2398	1	25052501
U001	P8001A	SOCKET	NSCT-21P2412	1	25052515
U001	P8002A	SOCKET	NSCT-9P2400	1	25052503
U001	P8003B	PLUG	NPLG-7P0962	1	25056012
U001	RL660	RELAY	NRL-2P5A-DC24-129	1	25065563A
U001	RL660 or	RELAY	NRL-2P8A-DC24-144	(1)	25065590
U001	RL660 or	RELAY	NRL-2P5A-DC24-193	(1)	25065703
U001	RL662	RELAY	NRL-2P5A-DC24-129	1	25065563A
U001	RL662 or	RELAY	NRL-2P8A-DC24-144	(1)	25065590
U001	RL662 or	RELAY	NRL-2P5A-DC24-193	(1)	25065703
U001	RL663	RELAY	NRL-2P5A-DC24-129	1	25065563A
U001	RL663 or	RELAY	NRL-2P8A-DC24-144	(1)	25065590
U001	RL663 or	RELAY	NRL-2P5A-DC24-193	(1)	25065703
U001	RL669	RELAY	NRL-2P5A-DC24-129	1	25065563A
U001	RL669 or	RELAY	NRL-2P8A-DC24-144	(1)	25065590
U001	RL669 or	RELAY	NRL-2P5A-DC24-193	(1)	25065703
U001	RL691	RELAY	NRL-1P10A-DC12-196	1	25065707
U001	RL691 or	RELAY	NRL-1P10A-DC12-197	(1)	25065708
U001	RL691 or	RELAY	NRL-1P10A-DC12-198	(1)	25065709
U001	RL692	RELAY	NRL-1P10A-DC12-196	1	25065707
U001	RL692 or	RELAY	NRL-1P10A-DC12-197	(1)	25065708
U001	RL692 or	RELAY	NRL-1P10A-DC12-198	(1)	25065709
U001	RL693	RELAY	NRL-2P5A-DC24-129	1	25065563A
U001	[TUNER UNIT]				
U001	U131	PHT CP	JSR1165-001recieving	1	24120143
U001	U132	PHT CP	JSR1165-001recieving	1	24120143

U002	U002	U0020 + U0021 + U0022 + U0023 + U0024	
U002	U0020	Display PC board ass'y	BADIS-0654-1D
U002	U0021	Standby switch PC board ass'y	BADIS-0655-1D
U002	U0022	Video PC board ass'y	BAVD-0656-1D
U002	U0023	HP Jack PC board ass'y	BAETC-0658-1D
U002	U0024	Primary Wiring PC board ass'y	BAPS-0659-1D

U002

U002	CIRCUIT NO.	PART NAME	DESCRIPTION	Q'TY	PART NO. (SN)	REMARKS
U002	[SEMI CONDUCTOR]					
U002	D7002	ZENER D	DZ2J082M0L	1	224760820R2	
U002	D7002 or	ZENER D	UDZS8.2B	(1)	224550820R2	
U002	D7033	ZENER D	DZ2J039M0L	1	224760390R2	
U002	D7033 or	ZENER D	UDZS3.9B	(1)	224550390R2	
U002	D7152	LED	SLI-343Y8C-TE7	1	225490T	
U002	D7301	C-DIODE	DA2J10100	1	223303R2	N
U002	D7301 or	C-DIODE	1SS352	(1)	223234R2	
U002	D7301 or	C-DIODE	1SS355	(1)	223269R2	
U002	D7301 or	C-DIODE	MA2J111	(1)	223279R2	
U002	D7301 or	C-DIODE	KDS4148U	(1)	223283R2	
U002	D7302	C-DIODE	DA2J10100	1	223303R2	N
U002	D7302 or	C-DIODE	1SS352	(1)	223234R2	
U002	D7302 or	C-DIODE	1SS355	(1)	223269R2	
U002	D7302 or	C-DIODE	MA2J111	(1)	223279R2	
U002	D7302 or	C-DIODE	KDS4148U	(1)	223283R2	
U002	D7401	ZENER D	DZ2J051M0L	1	224760510R2	
U002	D7401 or	ZENER D	UDZS5.1B	(1)	224550510R2	
U002	D7411	ZENER D	DZ2J068M0L	1	224760680R2	
U002	D7411 or	ZENER D	UDZS6.8B	(1)	224550680R2	
U002	D7412	ZENER D	DZ2J068M0L	1	224760680R2	
U002	D7412 or	ZENER D	UDZS6.8B	(1)	224550680R2	
U002	D7501	C-DIODE	DA2J10100	1	223303R2	
U002	D7501 or	C-DIODE	1SS352	(1)	223234R2	
U002	D7501 or	C-DIODE	1SS355	(1)	223269R2	
U002	D7501 or	C-DIODE	MA2J111	(1)	223279R2	
U002	D7501 or	C-DIODE	KDS4148U	(1)	223283R2	
U002	D7502	C-DIODE	DA2J10100	1	223303R2	
U002	D7502 or	C-DIODE	1SS352	(1)	223234R2	
U002	D7502 or	C-DIODE	1SS355	(1)	223269R2	

U002	D7502 or	C-DIODE	MA2J111	(1)	223279R2	
U002	D7502 or	C-DIODE	KDS4148U	(1)	223283R2	
U002	D7503	C-DIODE	DA2J10100	1	223303R2	
U002	D7503 or	C-DIODE	1SS352	(1)	223234R2	
U002	D7503 or	C-DIODE	1SS355	(1)	223269R2	
U002	D7503 or	C-DIODE	MA2J111	(1)	223279R2	
U002	D7503 or	C-DIODE	KDS4148U	(1)	223283R2	
U002	D7504	C-DIODE	DA2J10100	1	223303R2	
U002	D7504 or	C-DIODE	1SS352	(1)	223234R2	
U002	D7504 or	C-DIODE	1SS355	(1)	223269R2	
U002	D7504 or	C-DIODE	MA2J111	(1)	223279R2	
U002	D7504 or	C-DIODE	KDS4148U	(1)	223283R2	
U002	D9011	DIODE	D5SBA60	1	22380070F	N
U002	D9014	C-DIODE	DA2J10100	1	223303R2	N
U002	D9014 or	C-DIODE	1SS352	(1)	223234R2	
U002	D9014 or	C-DIODE	1SS355	(1)	223269R2	
U002	D9014 or	C-DIODE	MA2J111	(1)	223279R2	
U002	D9014 or	C-DIODE	KDS4148U	(1)	223283R2	
U002	D9015	C-DIODE	DA2J10100	1	223303R2	N
U002	D9015 or	C-DIODE	1SS352	(1)	223234R2	
U002	D9015 or	C-DIODE	1SS355	(1)	223269R2	
U002	D9015 or	C-DIODE	MA2J111	(1)	223279R2	
U002	D9015 or	C-DIODE	KDS4148U	(1)	223283R2	
U002	D9016	ZENER D	DZ2J062M0L	1	224760620R2	
U002	D9016 or	ZENER D	UDZS6.2B	(1)	224550620R2	
U002	D911	C-DIODE	DA2J10100	1	223303R2	N
U002	D911 or	C-DIODE	1SS352	(1)	223234R2	
U002	D911 or	C-DIODE	1SS355	(1)	223269R2	
U002	D911 or	C-DIODE	MA2J111	(1)	223279R2	
U002	D911 or	C-DIODE	KDS4148U	(1)	223283R2	
U002	D912	C-DIODE	DA2J10100	1	223303R2	N
U002	D912 or	C-DIODE	1SS352	(1)	223234R2	
U002	D912 or	C-DIODE	1SS355	(1)	223269R2	
U002	D912 or	C-DIODE	MA2J111	(1)	223279R2	
U002	D912 or	C-DIODE	KDS4148U	(1)	223283R2	
U002	D921	C-DIODE	DA2J10100	1	223303R2	N
U002	D921 or	C-DIODE	1SS352	(1)	223234R2	
U002	D921 or	C-DIODE	1SS355	(1)	223269R2	
U002	D921 or	C-DIODE	MA2J111	(1)	223279R2	

U002	D921 or	C-DIODE	KDS4148U	(1)	223283R2	
U002	D922	C-DIODE	DA2J10100	1	223303R2	N
U002	D922 or	C-DIODE	1SS352	(1)	223234R2	
U002	D922 or	C-DIODE	1SS355	(1)	223269R2	
U002	D922 or	C-DIODE	MA2J111	(1)	223279R2	
U002	D922 or	C-DIODE	KDS4148U	(1)	223283R2	
U002	D923	C-DIODE	DA2J10100	1	223303R2	N
U002	D923 or	C-DIODE	1SS352	(1)	223234R2	
U002	D923 or	C-DIODE	1SS355	(1)	223269R2	
U002	D923 or	C-DIODE	MA2J111	(1)	223279R2	
U002	D923 or	C-DIODE	KDS4148U	(1)	223283R2	
U002	D924	C-DIODE	DA2J10100	1	223303R2	N
U002	D924 or	C-DIODE	1SS352	(1)	223234R2	
U002	D924 or	C-DIODE	1SS355	(1)	223269R2	
U002	D924 or	C-DIODE	MA2J111	(1)	223279R2	
U002	D924 or	C-DIODE	KDS4148U	(1)	223283R2	
U002	D925	C-DIODE	DA2J10100	1	223303R2	N
U002	D925 or	C-DIODE	1SS352	(1)	223234R2	
U002	D925 or	C-DIODE	1SS355	(1)	223269R2	
U002	D925 or	C-DIODE	MA2J111	(1)	223279R2	
U002	D925 or	C-DIODE	KDS4148U	(1)	223283R2	
U002	D930	C-DIODE	DA2J10100	1	223303R2	N
U002	D930 or	C-DIODE	1SS352	(1)	223234R2	
U002	D930 or	C-DIODE	1SS355	(1)	223269R2	
U002	D930 or	C-DIODE	MA2J111	(1)	223279R2	
U002	D930 or	C-DIODE	KDS4148U	(1)	223283R2	
U002	D931	C-DIODE	DA2J10100	1	223303R2	N
U002	D931 or	C-DIODE	1SS352	(1)	223234R2	
U002	D931 or	C-DIODE	1SS355	(1)	223269R2	
U002	D931 or	C-DIODE	MA2J111	(1)	223279R2	
U002	D931 or	C-DIODE	KDS4148U	(1)	223283R2	
U002	D933	C-DIODE	DA2J10100	1	223303R2	N
U002	D933 or	C-DIODE	1SS352	(1)	223234R2	
U002	D933 or	C-DIODE	1SS355	(1)	223269R2	
U002	D933 or	C-DIODE	MA2J111	(1)	223279R2	
U002	D933 or	C-DIODE	KDS4148U	(1)	223283R2	
U002	D934	ZENER D	DZ2J051M0L	1	224760510R2	
U002	D934 or	ZENER D	UDZS5.1B	(1)	224550510R2	
U002	D935	C-DIODE	DA2J10100	1	223303R2	N

U002	D935 or	C-DIODE	ISS352	(1)	223234R2	
U002	D935 or	C-DIODE	ISS355	(1)	223269R2	
U002	D935 or	C-DIODE	MA2J111	(1)	223279R2	
U002	D935 or	C-DIODE	KDS4148U	(1)	223283R2	
U002	Q2001	IC	NJW1328	1	22242691R3	N
U002	Q2600	IC	NJM2505AF	1	22242490R2	
U002	Q2600 or	IC	BH7673G-TR	(1)	22242661R2	
U002	Q7002	FL TUBE	16-BT-162GNK	1	212273	
U002	Q7002A	HOLDER	(FL)	1	27191222C	
U002	Q7003	IC	M66005-0001AHP	1	22242208R3	
U002	Q7004	TR	KTC3875-GR	1	2216175R2	
U002	Q7005	TR	KRA102S	1	2216220R2	
U002	Q7007	TR	KRC102S	1	2216190R2	
U002	Q7033	TR	KTC3875-GR	1	2216175R2	
U002	Q7401	IC	NJM4580M-D	1	22241448R2	
U002	Q7403	TR	DTC114TKA	1	2216670R2	
U002	Q7404	TR	DTC114TKA	1	2216670R2	
U002	Q9020	IC	XC6220B501PR	1	22242692R2	N
U002	[TRANS COIL]					
U002	L7031	CHOKE COIL	LBC2518T2R2M	1	231364M022R2	
U002	L7032	CHOKE COIL	LBC2518T2R2M	1	231364M022R2	
U002	L7201	CHOKE COIL	LBC2518T2R2M	1	231364M022R2	
U002	L7202	CHOKE COIL	LBC2518T2R2M	1	231364M022R2	
U002	L7203	CHOKE COIL	LBC2518T2R2M	1	231364M022R2	
U002	L7301	EMIFIL	BK1608LM182-T	1	230958R1	
U002	L7302	EMIFIL	BK1608LM182-T	1	230958R1	
U002	L7401	CHOKE COIL	LBC2518T2R2M	1	231364M022R2	
U002	L7402	CHOKE COIL	LBC2518T2R2M	1	231364M022R2	
U002	L7501	CORE	BLM18PG121SN1D	1	2350006R1	
U002	L7502	CORE	BLM18PG121SN1D	1	2350006R1	
U002	L7503	CORE	BLM18PG121SN1D	1	2350006R1	
U002	L9020	CORE	BLM18PG181SN1D	1	2350005R1	
U002	T902	P TRANS	NPT-1520GQ	1	2301813A	!
U002	[CAPACITOR]					
U002	C2000	C-CERA C	CK725F1E-104Z1	1	332161040R1	
U002	C2001	C-CERA C	CK725F1E-104Z1	1	332161040R1	
U002	C2002	VR C	CE04W50V-2.2M(VR)	1	394680227T	
U002	C2002 or	JAMICON	CE04W50V-2.2M	(1)	398580227T	N
U002	C2004	C-CERA C	CK725F1E-104Z1	1	332161040R1	

U002	C2006	C-CERA C	CK725F1A-105Z1	1	332181050R1	
U002	C2007	C-CERA C	CK725F1E-104Z1	1	332161040R1	
U002	C2008	C-CERA C	CK725F1A-105Z1	1	332181050R1	
U002	C2009	C-CERA C	CK725F1A-105Z1	1	332181050R1	
U002	C2010	C-CERA C	CK725F1A-105Z1	1	332181050R1	
U002	C2011	C-CERA C	CK725F1A-105Z1	1	332181050R1	
U002	C2012	C-CERA C	CK725F1A-105Z1	1	332181050R1	
U002	C2013	VR C	CE04W50V-10M(VR)	1	394681007T	
U002	C2013 or	JAMICON	CE04W50V-10M	(1)	398581007T	N
U002	C2020	C-CERA C	CK725F1A-105Z1	1	332181050R1	
U002	C2021	C-CERA C	CK725F1A-105Z1	1	332181050R1	
U002	C2102	VR C	CE04W6.3V-470M(VR)	1	394624717T	
U002	C2102 or	JAMICON	CE04W6.3V-470M	(1)	398524717T	N
U002	C2103	VR C	CE04W50V-2.2M(VR)	1	394680227T	
U002	C2103 or	JAMICON	CE04W50V-2.2M	(1)	398580227T	N
U002	C2104	VR C	CE04W50V-2.2M(VR)	1	394680227T	
U002	C2104 or	JAMICON	CE04W50V-2.2M	(1)	398580227T	N
U002	C2105	VR C	CE04W6.3V-470M(VR)	1	394624717T	
U002	C2105 or	JAMICON	CE04W6.3V-470M	(1)	398524717T	N
U002	C2106	VR C	CE04W50V-2.2M(VR)	1	394680227T	
U002	C2106 or	JAMICON	CE04W50V-2.2M	(1)	398580227T	N
U002	C2107	VR C	CE04W50V-2.2M(VR)	1	394680227T	
U002	C2107 or	JAMICON	CE04W50V-2.2M	(1)	398580227T	N
U002	C2108	VR C	CE04W6.3V-470M(VR)	1	394624717T	
U002	C2108 or	JAMICON	CE04W6.3V-470M	(1)	398524717T	N
U002	C2109	VR C	CE04W6.3V-470M(VR)	1	394624717T	
U002	C2109 or	JAMICON	CE04W6.3V-470M	(1)	398524717T	N
U002	C2110	VR C	CE04W6.3V-470M(VR)	1	394624717T	
U002	C2110 or	JAMICON	CE04W6.3V-470M	(1)	398524717T	N
U002	C2111	VR C	CE04W50V-2.2M(VR)	1	394680227T	
U002	C2111 or	JAMICON	CE04W50V-2.2M	(1)	398580227T	N
U002	C2112	VR C	CE04W50V-2.2M(VR)	1	394680227T	
U002	C2112 or	JAMICON	CE04W50V-2.2M	(1)	398580227T	N
U002	C2113	VR C	CE04W50V-2.2M(VR)	1	394680227T	
U002	C2113 or	JAMICON	CE04W50V-2.2M	(1)	398580227T	N
U002	C2114	VR C	CE04W50V-2.2M(VR)	1	394680227T	
U002	C2114 or	JAMICON	CE04W50V-2.2M	(1)	398580227T	N
U002	C2115	VR C	CE04W50V-2.2M(VR)	1	394680227T	
U002	C2115 or	JAMICON	CE04W50V-2.2M	(1)	398580227T	N

U002	C2116	VR C	CE04W50V-2.2M(VR)	1	394680227T	
U002	C2116 or	JAMICON	CE04W50V-2.2M	(1)	398580227T	N
U002	C2201	C-CERA C	CK725B1H-102K1	1	332101025R1	
U002	C2202	C-CERA C	CK725B1H-102K1	1	332101025R1	
U002	C2203	C-CERA C	CK725B1H-103K1	1	332101035R1	
U002	C2601	C-CERA C	CK725F1E-104Z1	1	332161040R1	
U002	C2602	VR C	CE04W6.3V-470M(VR)	1	394624717T	
U002	C2602 or	JAMICON	CE04W6.3V-470M	(1)	398524717T	
U002	C2603	C-CERA C	CC725CH1H-470J1	1	342104704R1	
U002	C2604	VR C	CE04W6.3V-470M(VR)	1	394624717T	
U002	C2604 or	JAMICON	CE04W6.3V-470M	(1)	398524717T	
U002	C2605	C-CERA C	CC725CH1H-470J1	1	342104704R1	
U002	C7001	C-CERA C	CK725B1H-223K1	1	332102235R1	
U002	C7002	C-CERA C	CK725F1E-104Z1	1	332161040R1	
U002	C7003	C-CERA C	CC725CH1H-101J1	1	342101014R1	
U002	C7004	C-CERA C	CC725CH1H-101J1	1	342101014R1	
U002	C7005	C-CERA C	CC725CH1H-101J1	1	342101014R1	
U002	C7007	C-CERA C	CC725CH1H-101J1	1	342101014R1	
U002	C7008	ELECT C	CE04W6.3V-100M(S)	1	353721019T	
U002	C7009	C-CERA C	CK725F1E-104Z1	1	332161040R1	
U002	C7010	C-CERA C	CK725B1H-223K1	1	332102235R1	
U002	C7011	C-CERA C	CK725B1H-223K1	1	332102235R1	
U002	C7012	C-CERA C	CK725B1H-223K1	1	332102235R1	
U002	C7014	C-CERA C	CK725B1H-223K1	1	332102235R1	
U002	C7015	ELECT C	CE04W16V-47M(S)	1	353744709T	
U002	C7016	C-CERA C	CK725B1H-223K1	1	332102235R1	
U002	C7017	C-CERA C	CK725B1H-223K1	1	332102235R1	
U002	C7021	C-CERA C	CK725B1H-103K1	1	332101035R1	
U002	C7022	C-CERA C	CK725B1H-103K1	1	332101035R1	
U002	C7031	C-CERA C	CK725B1H-223K1	1	332102235R1	
U002	C7032	C-CERA C	CK725B1H-223K1	1	332102235R1	
U002	C7033	ELECT C	CE04W16V-10M(S)	1	353741009T	
U002	C7041	ELECT C	CE04W16V-10M(S)	1	353741009T	
U002	C7042	C-CERA C	CC725CH1H-102J1	1	342101024R1	
U002	C7043	C-CERA C	CC725CH1H-102J1	1	342101024R1	
U002	C7201	C-CERA C	CC725CH1H-102J1	1	342101024R1	
U002	C7202	C-CERA C	CK725B1H-223K1	1	332102235R1	
U002	C7203	MKT C	B32529C0102J289	1	376491024T	
U002	C7204	MKT C	B32529C0102J289	1	376491024T	

U002	C7301	C-CERA C	CC725CH1H-471J1	1	342104714R1	
U002	C7302	C-CERA C	CC725CH1H-471J1	1	342104714R1	
U002	C7304	C-CERA C	CK725F1E-104Z1	1	332161040R1	
U002	C7305	C-CERA C	CK725F1E-104Z1	1	332161040R1	
U002	C7306	C-CERA C	CK725F1E-104Z1	1	332161040R1	
U002	C7319	C-CERA C	CC725CH1H-470J1	1	342104704R1	
U002	C7401	ELECT C	CE04W16V-10M(S)	1	353741009T	
U002	C7402	C-CERA C	CC725CH1H-101J1	1	342101014R1	
U002	C7403	ELECT C	CE04W16V-47M(S)	1	353744709T	
U002	C7404	C-CERA C	CC725CH1H-330J1	1	342103304R1	
U002	C7405	ELECT C	CE04W16V-10M(S)	1	353741009T	
U002	C7411	ELECT C	CE04W16V-47M(S)	1	353744709T	
U002	C7412	ELECT C	CE04W16V-47M(S)	1	353744709T	
U002	C7421	C-CERA C	CC725CH1H-102J1	1	342101024R1	
U002	C7501	C-CERA C	CK725F1E-104Z1	1	332161040R1	
U002	C7503	C-CERA C	CK725F1E-104Z1	1	332161040R1	
U002	C901	IS C	LE103-C3.5	1	3800042S	!
U002	C901 or	IS C	ECQU2A103MLC	(1)	3800039S	!
U002	C9011	VR C	CE04W16V-10000M(VR)	1	394641037S	
U002	C9012	TF C	ECQ-V50V-334J	1	374723344T	
U002	C9013	VR C	CE04W50V-4.7M(VR)	1	394680477T	
U002	C9013 or	JAMICON	CE04W50V-4.7M	(1)	398580477T	N
U002	C902	C-CERA C	CK725F1E-104Z1	1	332161040R1	
U002	C9020	C-CERA C	CK732B16V-106K	1	332071065R2	N
U002	C9021	C-CERA C	CK732B16V-106K	1	332071065R2	N
U002	C9022	C-CERA C	CK732B16V-106K	1	332071065R2	N
U002	C9023	C-CERA C	CK732B16V-106K	1	332071065R2	N
U002	C9026	VR C	CE04W6.3V-470M(VR)	1	394624717T	
U002	C9026 or	JAMICON	CE04W6.3V-470M	(1)	398524717T	N
U002	C9027	C-CERA C	CK725F1E-104Z1	1	332161040R1	
U002	C9028	C-CERA C	CK725F1E-104Z1	1	332161040R1	
U002	C9029	C-CERA C	CK725F1E-104Z1	1	332161040R1	
U002	C9030	C-CERA C	CK725F1E-104Z1	1	332161040R1	
U002	C9031	C-CERA C	CK725F1E-104Z1	1	332161040R1	
U002	C911	C-CERA C	CC725CH1H-102J1	1	342101024R1	
U002	C921	C-CERA C	CK725B1H-223K1	1	332102235R1	
U002	C922	VR C	CE04W16V-2200M(VR)	1	394642227S	
U002	C922 or	JAMICON	CE04W16V-2200M	(1)	398542227S	
U002	C930	VR C	CE04W16V-470M(VR)	1	394644717T	

U002	C930 or	JAMICON	CE04W16V-470M	(1)	398544717T
U002	C933	UTSP C	CE04W50V-4.7M(UTSP)	1	397580477T
U002	[RESISTOR]				
U002	R2004	C-CARBON R	RN72K1J-563JE	1	435035634R1
U002	R2005	C-CARBON R	RN72K1J-103JE	1	435031034R1
U002	R2006	C-CARBON R	RN72K1J-103JE	1	435031034R1
U002	R2007	C-CARBON R	RN72K1J-563JE	1	435035634R1
U002	R2008	C-CARBON R	RN72K1J-222JE	1	435032224R1
U002	R2009	C-CARBON R	RN72K1J-222JE	1	435032224R1
U002	R2010	C-CARBON R	RN72K1J-183JE	1	435031834R1
U002	R2011	C-CARBON R	RN72K1J-183JE	1	435031834R1
U002	R2101	C-CARBON R	RN72K1J-750JE	1	435037504R1
U002	R2102	C-CARBON R	RN72K1J-750JE	1	435037504R1
U002	R2103	C-CARBON R	RN72K1J-750JE	1	435037504R1
U002	R2104	C-CARBON R	RN72K1J-750JE	1	435037504R1
U002	R2105	C-CARBON R	RN72K1J-750JE	1	435037504R1
U002	R2106	C-CARBON R	RN72K1J-750JE	1	435037504R1
U002	R2107	C-CARBON R	RN72K1J-750JE	1	435037504R1
U002	R2108	C-CARBON R	RN72K1J-750JE	1	435037504R1
U002	R2109	C-CARBON R	RN72K1J-750JE	1	435037504R1
U002	R2110	C-CARBON R	RN72K1J-750JE	1	435037504R1
U002	R2111	C-CARBON R	RN72K1J-750JE	1	435037504R1
U002	R2112	C-CARBON R	RN72K1J-750JE	1	435037504R1
U002	R2113	C-CARBON R	RN72K1J-750JE	1	435037504R1
U002	R2114	C-CARBON R	RN72K1J-750JE	1	435037504R1
U002	R2115	C-CARBON R	RN72K1J-750JE	1	435037504R1
U002	R2116	C-CARBON R	RN72K1J-750JE	1	435037504R1
U002	R2120	C-CARBON R	RN72K1J-104JE	1	435031044R1
U002	R2121	C-CARBON R	RN72K1J-104JE	1	435031044R1
U002	R2122	C-CARBON R	RN72K1J-104JE	1	435031044R1
U002	R2123	C-CARBON R	RN72K1J-104JE	1	435031044R1
U002	R2124	C-CARBON R	RN72K1J-104JE	1	435031044R1
U002	R2155	C-CARBON R	RN72K1J-000JE	1	435030004R1
U002	R2156	C-CARBON R	RN72K1J-000JE	1	435030004R1
U002	R2157	C-CARBON R	RN72K1J-000JE	1	435030004R1
U002	R2601	C-CARBON R	RN72K1J-220JE	1	435032204R1
U002	R2602	C-CARBON R	RN72K1J-220JE	1	435032204R1
U002	R2603	C-CARBON R	RN72K1J-047JE	1	435030474R1
U002	R7001	C-CARBON R	RN72K1J-103JE	1	435031034R1

U002	R7002	C-CARBON R	RN72K1J-332JE	1	435033324R1
U002	R7003	C-CARBON R	RN72K1J-332JE	1	435033324R1
U002	R7004	C-CARBON R	RN72K1J-221JE	1	435032214R1
U002	R7005	C-CARBON R	RN72K1J-221JE	1	435032214R1
U002	R7006	C-CARBON R	RN72K1J-103JE	1	435031034R1
U002	R7007	C-CARBON R	RN72K1J-221JE	1	435032214R1
U002	R7008	C-CARBON R	RN72K1J-221JE	1	435032214R1
U002	R7021	C-CARBON R	RN72K1J-103JE	1	435031034R1
U002	R7022	C-CARBON R	RN72K1J-103JE	1	435031034R1
U002	R7023	C-CARBON R	RN72K1J-103JE	1	435031034R1
U002	R7024	C-CARBON R	RN72K1J-103JE	1	435031034R1
U002	R7033	C-CARBON R	RN72K1J-820JE	1	435038204R1
U002	R7041	C-CARBON R	RN72K1J-101JE	1	435031014R1
U002	R7042	C-CARBON R	RN72K1J-102JE	1	435031024R1
U002	R7101	C-CARBON R	RN72K1J-271JE	1	435032714R1
U002	R7102	C-CARBON R	RN72K1J-331JE	1	435033314R1
U002	R7103	C-CARBON R	RN72K1J-471JE	1	435034714R1
U002	R7106	C-CARBON R	RN72K1J-271JE	1	435032714R1
U002	R7107	C-CARBON R	RN72K1J-331JE	1	435033314R1
U002	R7108	C-CARBON R	RN72K1J-471JE	1	435034714R1
U002	R7109	C-CARBON R	RN72K1J-561JE	1	435035614R1
U002	R7110	C-CARBON R	RN72K1J-821JE	1	435038214R1
U002	R7111	C-CARBON R	RN72K1J-122JE	1	435031224R1
U002	R7112	C-CARBON R	RN72K1J-222JE	1	435032224R1
U002	R7113	C-CARBON R	RN72K1J-392JE	1	435033924R1
U002	R7114	C-CARBON R	RN72K1J-123JE	1	435031234R1
U002	R7115	C-CARBON R	RN72K1J-271JE	1	435032714R1
U002	R7116	C-CARBON R	RN72K1J-331JE	1	435033314R1
U002	R7117	C-CARBON R	RN72K1J-471JE	1	435034714R1
U002	R7118	C-CARBON R	RN72K1J-561JE	1	435035614R1
U002	R7119	C-CARBON R	RN72K1J-821JE	1	435038214R1
U002	R7120	C-CARBON R	RN72K1J-122JE	1	435031224R1
U002	R7121	C-CARBON R	RN72K1J-222JE	1	435032224R1
U002	R7122	C-CARBON R	RN72K1J-392JE	1	435033924R1
U002	R7123	C-CARBON R	RN72K1J-271JE	1	435032714R1
U002	R7124	C-CARBON R	RN72K1J-331JE	1	435033314R1
U002	R7125	C-CARBON R	RN72K1J-471JE	1	435034714R1
U002	R7126	C-CARBON R	RN72K1J-561JE	1	435035614R1
U002	R7127	C-CARBON R	RN72K1J-821JE	1	435038214R1

U002	R7128	C-CARBON R	RN72K1J-122JE	1	435031224R1	
U002	R7129	C-CARBON R	RN72K1J-222JE	1	435032224R1	
U002	R7152	C-CARBON R	RN72K1J-222JE	1	435032224R1	
U002	R7301	C-CARBON R	RN72K1J-331JE	1	435033314R1	
U002	R7302	C-CARBON R	RN72K1J-331JE	1	435033314R1	
U002	R7401	C-CARBON R	RN72K1J-101JE	1	435031014R1	
U002	R7402	C-CARBON R	RN72K1J-224JE	1	435032244R1	
U002	R7403	C-CARBON R	RN72K1J-472JE	1	435034724R1	
U002	R7404	C-CARBON R	RN72K1J-221JE	1	435032214R1	
U002	R7405	C-CARBON R	RN72K1J-473JE	1	435034734R1	
U002	R7406	C-CARBON R	RN72K1J-331JE	1	435033314R1	
U002	R7407	C-CARBON R	RN72K1J-102JE	1	435031024R1	
U002	R7408	C-CARBON R	RN72K1J-333JE	1	435033334R1	
U002	R7409	C-CARBON R	RN72K1J-221JE	1	435032214R1	
U002	R7410	C-CARBON R	RN72K1J-221JE	1	435032214R1	
U002	R7411	C-CARBON R	RN72K1J-471JE	1	435034714R1	
U002	R7412	C-CARBON R	RN72K1J-471JE	1	435034714R1	
U002	R7413	C-CARBON R	RN72K1J-224JE	1	435032244R1	
U002	R7414	C-CARBON R	RN72K1J-104JE	1	435031044R1	
U002	R7420	C-CARBON R	RN72K1J-473JE	1	435034734R1	
U002	R9014	C-CARBON R	RN72K1J-104JE	1	435031044R1	
U002	R921	METAL O R	RS1/2WBJ-47	1	443524704T	
U002	R934	C-CARBON R	RN72K1J-104JE	1	435031044R1	
U002	[SW TRM]					
U002	E7201	TRM-423(SCREW)	NEJITANSI ST3	1	25060495	
U002	E7301A	RETAINER	(GND)	1	27142222A	N
U002	E9004	RETAINER	(JOINT)	1	27142069	
U002	E901	TRM-423(SCREW)	NEJITANSI ST3	1	25060495	
U002	E902	TRM-423(SCREW)	NEJITANSI ST3	1	25060495	
U002	F9001	FUSE	5A-UL-125V	1	252385T	!
U002	F901C	FUSE HOL	NSCT-1P2031	1	25052133T	!
U002	F901D	FUSE HOL	NSCT-1P2031	1	25052133T	!
U002	F901E	LABEL	T4AL250V	1	29361732A	
U002	JL605A	WIRE HOL	NSCT-5P896	1	25051109	
U002	JL702A	WIRE HOL	NSCT-7P878	1	25051091	
U002	JL702B	WIRE HOL	NSCT-7P878	1	25051091	
U002	JL801A	WIRE HOL	NSCT-5P876	1	25051089	
U002	JL901A	WIRE HOL	NSCT-5P876	1	25051089	
U002	JL952B	SOCKET	NSCT-3P95	1	25050267	

U002	JL953A	WIRE HOL	NSCT-5P876	1	25051089	
U002	P2201	PIN JACK	NPJ-3PDYYYY560	1	25045778	
U002	P2202	PIN JACK	NPJ-3PDYYYY560	1	25045778	
U002	P2203	PIN JACK	NPJ-9PDGLRGLRGLR563	1	25045781	
U002	P2800A	SOCKET	NSCT-9P2400	1	25052503	
U002	P3101B	PLUG	NPLG-5P352	1	25055369	
U002	P701B	SOCKET	NSCT-23P2441	1	25052544	
U002	P703A	SOCKET	NSCT-7P2425	1	25052528	
U002	P7201	ST JACK	MSJ-064-05A SR	1	25045783	
U002	P7201 or	ST JACK	YKB21-5005	(1)	25045724	
U002	P7301	PIN JACK	NPJ-3PDB720	1	25045957	
U002	P7401	ST JACK	MSJ-035-05C B AG SR type	1	25045879	
U002	P7501	SOCKET	000010211-00027	1	25053411	
U002	P901A	PLUG	NPLG-2P631	1	25055675	!
U002	P901A or	PLUG	1-1123724-2	(1)	25056402	!
U002	P911	PLUG	NPLG-2P631	1	25055675	!
U002	P911 or	PLUG	1-1123724-2	(1)	25056402	!
U002	RL901	RELAY	NRL-1P5A-DC9-179	1	25065669	!
U002	RL901 or	RELAY	NRL-1P10A-DC9-188	(1)	25065693	!
U002	S7002	R ENCODE	EC12E2425WITH WASHER	1	25065655W	
U002	S7102	PUSH SW	NPS-111-S681	1	25035718T	
U002	S7104	PUSH SW	NPS-111-S681	1	25035718T	
U002	S7106	PUSH SW	NPS-111-S681	1	25035718T	
U002	S7108	PUSH SW	NPS-111-S681	1	25035718T	
U002	S7113	PUSH SW	NPS-111-S681	1	25035718T	
U002	S7115	PUSH SW	NPS-111-S681	1	25035718T	
U002	S7117	PUSH SW	NPS-111-S681	1	25035718T	
U002	S7119	PUSH SW	NPS-111-S681	1	25035718T	
U002	S7121	PUSH SW	NPS-111-S681	1	25035718T	
U002	S7123	PUSH SW	NPS-111-S681	1	25035718T	
U002	S7125	PUSH SW	NPS-111-S681	1	25035718T	
U002	S7127	PUSH SW	NPS-111-S681	1	25035718T	
U002	S7129	PUSH SW	NPS-111-S681	1	25035718T	
U002	S7132	PUSH SW	NPS-111-S681	1	25035718T	
U002	S7134	PUSH SW	NPS-111-S681	1	25035718T	
U002	S7136	PUSH SW	NPS-111-S681	1	25035718T	
U002	S7138	PUSH SW	NPS-111-S681	1	25035718T	
U002	S7140	PUSH SW	NPS-111-S681	1	25035718T	
U002	S7142	PUSH SW	NPS-111-S681	1	25035718T	

U002	S7144	PUSH SW	NPS-111-S681	1	25035718T	
U002	S7146	PUSH SW	NPS-111-S681	1	25035718T	
U002	S7148	PUSH SW	NPS-111-S681	1	25035718T	
U002	S7150	PUSH SW	NPS-111-S681	1	25035718T	
U002	S7152	PUSH SW	NPS-111-S681	1	25035718T	
U002	S7154	PUSH SW	NPS-111-S681	1	25035718T	
U002	S7156	PUSH SW	NPS-111-S681	1	25035718T	
U002	S7158	PUSH SW	NPS-111-S681	1	25035718T	
U002	S7160	PUSH SW	NPS-111-S681	1	25035718T	
U002	S7162	PUSH SW	NPS-111-S681	1	25035718T	
U002	S7164	PUSH SW	NPS-111-S681	1	25035718T	
U002	[TUNER UNIT]					
U002	U7041	REMO SENS	KSM-603TE5B	1	24130019	
U003	U003	U0030 x 2 pcs.				
U003	U0030	HDMI PC board	BAHDM-0678-1F			
U003						
U003	CIRCUIT NO.	PART NAME	DESCRIPTION	Q'TY	PART NO. (SN)	REMARKS
U003	[SEMI CONDUCTOR]					
U003	D110	C-DIODE	DA2J10100	1	223303R2	N
U003	D110 or	C-DIODE	1SS352	(1)	223234R2	
U003	D110 or	C-DIODE	1SS355	(1)	223269R2	
U003	D110 or	C-DIODE	MA2J111	(1)	223279R2	
U003	D110 or	C-DIODE	KDS4148U	(1)	223283R2	
U003	D111	C-DIODE	DA2J10100	1	223303R2	N
U003	D111 or	C-DIODE	1SS352	(1)	223234R2	
U003	D111 or	C-DIODE	1SS355	(1)	223269R2	
U003	D111 or	C-DIODE	MA2J111	(1)	223279R2	
U003	D111 or	C-DIODE	KDS4148U	(1)	223283R2	
U003	D182	C-DIODE	DA2J10100	1	223303R2	N
U003	D182 or	C-DIODE	1SS352	(1)	223234R2	
U003	D182 or	C-DIODE	1SS355	(1)	223269R2	
U003	D182 or	C-DIODE	MA2J111	(1)	223279R2	
U003	D182 or	C-DIODE	KDS4148U	(1)	223283R2	
U003	D183	C-DIODE	DA2J10100	1	223303R2	N
U003	D183 or	C-DIODE	1SS352	(1)	223234R2	
U003	D183 or	C-DIODE	1SS355	(1)	223269R2	
U003	D183 or	C-DIODE	MA2J111	(1)	223279R2	
U003	D183 or	C-DIODE	KDS4148U	(1)	223283R2	

U003	D601	C-DIODE	DA2J10100	1	223303R2	N
U003	D601 or	C-DIODE	1SS352	(1)	223234R2	
U003	D601 or	C-DIODE	1SS355	(1)	223269R2	
U003	D601 or	C-DIODE	MA2J111	(1)	223279R2	
U003	D601 or	C-DIODE	KDS4148U	(1)	223283R2	
U003	D602	C-DIODE	DA2J10100	1	223303R2	N
U003	D602 or	C-DIODE	1SS352	(1)	223234R2	
U003	D602 or	C-DIODE	1SS355	(1)	223269R2	
U003	D602 or	C-DIODE	MA2J111	(1)	223279R2	
U003	D602 or	C-DIODE	KDS4148U	(1)	223283R2	
U003	D603	C-DIODE	DA2J10100	1	223303R2	N
U003	D603 or	C-DIODE	1SS352	(1)	223234R2	
U003	D603 or	C-DIODE	1SS355	(1)	223269R2	
U003	D603 or	C-DIODE	MA2J111	(1)	223279R2	
U003	D603 or	C-DIODE	KDS4148U	(1)	223283R2	
U003	D701	C-DIODE	DA2J10100	1	223303R2	N
U003	D701 or	C-DIODE	1SS352	(1)	223234R2	
U003	D701 or	C-DIODE	1SS355	(1)	223269R2	
U003	D701 or	C-DIODE	MA2J111	(1)	223279R2	
U003	D701 or	C-DIODE	KDS4148U	(1)	223283R2	
U003	D702	C-DIODE	DA2J10100	1	223303R2	N
U003	D702 or	C-DIODE	1SS352	(1)	223234R2	
U003	D702 or	C-DIODE	1SS355	(1)	223269R2	
U003	D702 or	C-DIODE	MA2J111	(1)	223279R2	
U003	D702 or	C-DIODE	KDS4148U	(1)	223283R2	
U003	D8100	C-DIODE	DA2J10100	1	223303R2	N
U003	D8100 or	C-DIODE	1SS352	(1)	223234R2	
U003	D8100 or	C-DIODE	1SS355	(1)	223269R2	
U003	D8100 or	C-DIODE	MA2J111	(1)	223279R2	
U003	D8100 or	C-DIODE	KDS4148U	(1)	223283R2	
U003	D8145	ESD D	AOZ8804ADI	1	225502R2	
U003	D8146	ESD D	AOZ8804ADI	1	225502R2	
U003	D8931	DIODE	RB050M-30	1	22380367R2	
U003	D8951	DIODE	RB050M-30	1	22380367R2	
U003	D8971	DIODE	RB050M-30	1	22380367R2	
U003	Q153	IC	R1EX25064ASA00A	1	22242581R2	
U003	Q181	TR	KRC105S	1	2217290R2	
U003	Q181 or	TR	RN1405	(1)	2214500R2	
U003	Q201	IC	D808K013BPTP	1	22242693R3	N

U003	Q271	IC	XC6220B121PR	1	22242626R2	
U003	Q272	IC	BU33TD3WG-TR	1	22242715R2	
U003	Q273	IC	XC6220B501PR	1	22242692R2	N
U003	Q275	IC	TPD2E001DRLR	1	22242589R2	
U003	Q276	IC	BD82065FVJ	1	22242718R2	
U003	Q277	IC	BU33TD3WG-TR	1	22242715R2	
U003	Q278	IC	BU18TD3WG-TR	1	22242716R2	
U003	Q281	IC	K4S641632N-LC60	1	22242603R2	
U003	Q281 or	IC	EM638165TS-7G	(1)	22242607R2	
U003	Q282	IC(DSP)	W25Q16CVSSIG(0406)	1	222W0118R204066	
U003	Q301	IC	PCM9211PTR	1	22242703R2	
U003	Q3105	IC	MF1341S2164	1	22242594R2	
U003	Q351	IC	PCM1681PWPR	1	22242697R2	N
U003	Q601	TR	KRC104S	1	2216210R2	
U003	Q601 or	TR	RN1404	(1)	2214490R2	
U003	Q701	IC(MAIN MICROPROCESSOR)	MPD70F3746GJ-GAE-AX(0405)	1	222W0079R304050	
U003	Q702	IC	S-812C33AUA-C2N	1	22242222R2	
U003	Q703	IC	S-812C56AUA-C3K	1	22242207R2	
U003	Q704	IC	SN74CB3Q3305PWR	1	22242258R2	
U003	Q746	IC	BU33TD3WG-TR	1	22242715R2	
U003	Q751	TR	KRC104S	1	2216210R2	
U003	Q751 or	TR	RN1404	(1)	2214490R2	
U003	Q752	TR	KRA102S	1	2216220R2	
U003	Q752 or	TR	RN2402	(1)	2214530R2	
U003	Q753	TR	KRA107S	1	2216350R2	
U003	Q753 or	TR	RN2407(TE85L_F)	(1)	2216360R2	
U003	Q754	TR	KRC102S	1	2216190R2	
U003	Q754 or	TR	RN1402	(1)	2214470R2	
U003	Q755	TR	KRA107S	1	2216350R2	
U003	Q755 or	TR	RN2407(TE85L_F)	(1)	2216360R2	
U003	Q756	TR	KRC102S	1	2216190R2	
U003	Q756 or	TR	RN1402	(1)	2214470R2	
U003	Q8101	IC	ADV7623	1	22242625R3	
U003	Q8104	IC	MM3404A50NRE	1	22242701R2	N
U003	Q8105	IC(HDMI/VIDEO)	W25Q16CVSSIG(0407)	1	222W0118R204075	
U003	Q8111	TR	KRC101S	1	2216330R2	
U003	Q8111 or	TR	RN1401(TE85L_F)	(1)	2214460R2	
U003	Q8112	TR	KRC101S	1	2216330R2	
U003	Q8112 or	TR	RN1401(TE85L_F)	(1)	2214460R2	

U003	Q8113	TR	KRC101S	1	2216330R2
U003	Q8113 or	TR	RN1401(TE85L_F)	(1)	2214460R2
U003	Q8114	TR	KRC101S	1	2216330R2
U003	Q8114 or	TR	RN1401(TE85L_F)	(1)	2214460R2
U003	Q8115	TR	KRC101S	1	2216330R2
U003	Q8115 or	TR	RN1401(TE85L_F)	(1)	2214460R2
U003	Q8116	TR	KRC101S	1	2216330R2
U003	Q8116 or	TR	RN1401(TE85L_F)	(1)	2214460R2
U003	Q8117	TR	KRC101S	1	2216330R2
U003	Q8117 or	TR	RN1401(TE85L_F)	(1)	2214460R2
U003	Q8118	TR	KRC101S	1	2216330R2
U003	Q8118 or	TR	RN1401(TE85L_F)	(1)	2214460R2
U003	Q8156	TR ARRAY	UM6K1N	1	226066R2
U003	Q8931	IC	MP2363DN-LF-Z	1	22242627R2
U003	Q8951	IC	MP2363DN-LF-Z	1	22242627R2
U003	Q8971	IC	MP2363DN-LF-Z	1	22242627R2
U003	Q8972	IC	BU18TD3WG-TR	1	22242716R2
U003	[TRANS COIL]				
U003	L153	CORE	BLM18PG181SN1D	1	2350005R1
U003	L201	C-CARBON R	RN72K1J-000JE	1	435030004R1
U003	L251	CORE	BLM18PG121SN1D	1	2350006R1
U003	L252	CORE	BLM18PG121SN1D	1	2350006R1
U003	L253	CORE	BLM18PG121SN1D	1	2350006R1
U003	L254	CORE	BLM18PG181SN1D	1	2350005R1
U003	L255	CORE	BLM18PG121SN1D	1	2350006R1
U003	L271	CORE	BLM18PG181SN1D	1	2350005R1
U003	L273	CORE	BLM18PG181SN1D	1	2350005R1
U003	L281	CORE	BLM18PG181SN1D	1	2350005R1
U003	L301	EMIFIL	BK1608LM182-T	1	230958R1
U003	L302	EMIFIL	BK1608LL241-T	1	230959R1
U003	L303	CHOKE COIL	LBC2518T4R7M	1	231364M047R2
U003	L304	CHOKE COIL	LBC2518T4R7M	1	231364M047R2
U003	L305	CHOKE COIL	LBC2518T4R7M	1	231364M047R2
U003	L351	CHOKE COIL	LBC2518T4R7M	1	231364M047R2
U003	L352	CHOKE COIL	LBC2518T4R7M	1	231364M047R2
U003	L500	CORE	BLM18PG181SN1D	1	2350005R1
U003	L740	CORE	BLM18PG181SN1D	1	2350005R1
U003	L742	CORE	BLM18PG181SN1D	1	2350005R1
U003	L743	CORE	BLM18PG181SN1D	1	2350005R1

U003	L744	CORE	BLM18PG181SN1D	1	2350005R1	
U003	L746	CORE	BLM18PG181SN1D	1	2350005R1	
U003	L8101	EMIFIL	BK1608LM182-T	1	230958R1	
U003	L8911	CORE	BLM18PG181SN1D	1	2350005R1	
U003	L8912	CORE	BLM18PG181SN1D	1	2350005R1	
U003	L8921	CORE	BLM18PG181SN1D	1	2350005R1	
U003	L8922	CORE	BLM18PG181SN1D	1	2350005R1	
U003	L8923	CORE	BLM18PG181SN1D	1	2350005R1	
U003	L8931	CHOKE COIL	CDRH8D43_100	1	231371P100R2	
U003	L8931 or	CHOKE COIL	0182-7E08Q-100M-RA	(1)	231396M100R2	
U003	L8931 or	CHOKE COIL	SWRH8D43C-100MT	(1)	231445M100R2	N
U003	L8932	CORE	BLM18PG181SN1D	1	2350005R1	
U003	L8933	CORE	BLM18PG181SN1D	1	2350005R1	
U003	L8934	CORE	BLM18PG181SN1D	1	2350005R1	
U003	L8937	CORE	BLM18PG181SN1D	1	2350005R1	
U003	L8938	CORE	BLM18PG181SN1D	1	2350005R1	
U003	L8939	CORE	BLM18PG181SN1D	1	2350005R1	
U003	L8951	CHOKE COIL	CDRH8D43_100	1	231371P100R2	
U003	L8951 or	CHOKE COIL	0182-7E08Q-100M-RA	(1)	231396M100R2	
U003	L8951 or	CHOKE COIL	SWRH8D43C-100MT	(1)	231445M100R2	N
U003	L8952	CORE	BLM18PG181SN1D	1	2350005R1	
U003	L8953	CORE	BLM18PG181SN1D	1	2350005R1	
U003	L8954	CORE	BLM18PG181SN1D	1	2350005R1	
U003	L8971	CHOKE COIL	CDRH8D43_100	1	231371P100R2	
U003	L8971 or	CHOKE COIL	0182-7E08Q-100M-RA	(1)	231396M100R2	
U003	L8971 or	CHOKE COIL	SWRH8D43C-100MT	(1)	231445M100R2	N
U003	L8972	CORE	BLM18PG181SN1D	1	2350005R1	
U003	L8973	CORE	BLM18PG181SN1D	1	2350005R1	
U003	L8974	CORE	BLM18PG181SN1D	1	2350005R1	
U003	X201	CRYSTAL	HC-49SMD24.000MHz	1	3010479R2	
U003	X301	CRYSTAL	HC-49SMD24.576MHz+/-50ppm	1	3010494R2	
U003	X501	CERA LOCK	CSTCR5M00G53-B0	1	3010356R2	
U003	X8100	CRYSTAL	HC-49USSMD28.6363MHz	1	3010491R2	
U003	[CAPACITOR]					
U003	C151	C-CERA C	CK725B1C-104K0	1	332011045R1	
U003	C201	C-CERA C	CK725B1A-105K0	1	332001055R1	
U003	C202	C-CERA C	CK725B1A-105K0	1	332001055R1	
U003	C203	C-CERA C	CK725B1A-105K0	1	332001055R1	
U003	C204	C-CERA C	CK725B1A-105K0	1	332001055R1	

U003	C205	C-CERA C	CK725B1A-105K0	1	332001055R1	
U003	C206	C-CERA C	CK725B1A-105K0	1	332001055R1	
U003	C207	C-CERA C	CK725B1A-105K0	1	332001055R1	
U003	C208	C-CERA C	CK725B1A-105K0	1	332001055R1	
U003	C209	C-CERA C	CK725B1A-105K0	1	332001055R1	
U003	C210	C-CERA C	CK725B1A-105K0	1	332001055R1	
U003	C211	C-CERA C	CK725B1A-105K0	1	332001055R1	
U003	C212	C-CERA C	CK725B1A-105K0	1	332001055R1	
U003	C213	C-CERA C	CK725B1A-105K0	1	332001055R1	
U003	C214	C-CERA C	CK725B1A-105K0	1	332001055R1	
U003	C215	C-CERA C	CK725B1A-105K0	1	332001055R1	
U003	C216	C-CERA C	CK725B1A-105K0	1	332001055R1	
U003	C217	C-CERA C	CK725B1A-105K0	1	332001055R1	
U003	C218	C-CERA C	CK725B1A-105K0	1	332001055R1	
U003	C219	C-CERA C	CK725B1A-105K0	1	332001055R1	
U003	C221	C-CERA C	CK725B1A-105K0	1	332001055R1	
U003	C222	C-CERA C	CK725B1A-105K0	1	332001055R1	
U003	C223	C-CERA C	CK725B1A-105K0	1	332001055R1	
U003	C224	C-CERA C	CK725B1A-105K0	1	332001055R1	
U003	C225	C-CERA C	CK725B1A-105K0	1	332001055R1	
U003	C226	C-CERA C	CK725B1A-105K0	1	332001055R1	
U003	C227	C-CERA C	CK725B1A-105K0	1	332001055R1	
U003	C228	C-CERA C	CK725B1A-105K0	1	332001055R1	
U003	C229	C-CERA C	CK725B1A-105K0	1	332001055R1	
U003	C230	C-CERA C	CK725B1A-105K0	1	332001055R1	
U003	C231	C-CERA C	CK725B1A-105K0	1	332001055R1	
U003	C232	C-CERA C	CK725B1A-105K0	1	332001055R1	
U003	C233	C-CERA C	CK725B1A-105K0	1	332001055R1	
U003	C234	C-CERA C	CK725B1A-105K0	1	332001055R1	
U003	C235	C-CERA C	CK725B1A-105K0	1	332001055R1	
U003	C236	C-CERA C	CK725B1A-105K0	1	332001055R1	
U003	C237	C-CERA C	CK725B1A-105K0	1	332001055R1	
U003	C238	C-CERA C	CK725B1A-105K0	1	332001055R1	
U003	C239	C-CERA C	CK725B1A-105K0	1	332001055R1	
U003	C240	C-CERA C	CK725B1A-105K0	1	332001055R1	
U003	C241	C-CERA C	CK725B1A-105K0	1	332001055R1	
U003	C242	C-CERA C	CK725B1A-105K0	1	332001055R1	
U003	C251	C-CERA C	CK732B16V-106K	1	332071065R2	
U003	C252	C-CERA C	CK732B16V-106K	1	332071065R2	N

U003	C253	C-CERA C	CK732B16V-106K	1	332071065R2	N
U003	C254	C-CERA C	CK732B16V-106K	1	332071065R2	N
U003	C255	C-CERA C	CK732B16V-106K	1	332071065R2	N
U003	C256	C-CERA C	CK725B1A-105K0	1	332001055R1	
U003	C261	C-CERA C	CK725B1A-224K0	1	332002245R1	
U003	C262	C-CERA C	CK725B1C-104K0	1	332011045R1	
U003	C263	C-CERA C	CK725B1C-103K0	1	332011035R1	
U003	C264	C-CERA C	CK725B1A-105K0	1	332001055R1	
U003	C265	C-CERA C	CC725CH1H-120J0	1	342031204R1	N
U003	C266	C-CERA C	CC725CH1H-120J0	1	342031204R1	N
U003	C267	C-CERA C	CK725B1H-102K0	1	332031025R1	
U003	C268	C-CERA C	CK725B1A-105K0	1	332001055R1	
U003	C269	C-CERA C	CK725B1A-105K0	1	332001055R1	
U003	C270	C-CERA C	CK732B16V-106K	1	332071065R2	N
U003	C271	C-CERA C	CK732B16V-106K	1	332071065R2	N
U003	C272	C-CERA C	CK732B16V-106K	1	332071065R2	N
U003	C273	C-CERA C	CK732B16V-106K	1	332071065R2	N
U003	C274	C-CERA C	CK725B1A-105K0	1	332001055R1	
U003	C275	CHIP ELECT C	CEWX10V-220M	1	398132217R2	
U003	C276	C-CERA C	CK725B1H-102K0	1	332031025R1	
U003	C277	CHIP ELECT C	CEWX16V-100M	1	398141017R2	
U003	C278	C-CERA C	CK725B1A-105K0	1	332001055R1	
U003	C279	C-CERA C	CK732B16V-106K	1	332071065R2	
U003	C280	C-CERA C	CK725B1A-105K0	1	332001055R1	
U003	C281	C-CERA C	CK732B16V-106K	1	332071065R2	
U003	C282	C-CERA C	CK732B16V-106K	1	332071065R2	N
U003	C283	C-CERA C	CK725B1A-105K0	1	332001055R1	
U003	C284	C-CERA C	CK725B1A-105K0	1	332001055R1	
U003	C285	C-CERA C	CK725B1A-105K0	1	332001055R1	
U003	C286	C-CERA C	CK725B1A-105K0	1	332001055R1	
U003	C287	C-CERA C	CK725B1A-105K0	1	332001055R1	
U003	C288	C-CERA C	CK725B1A-105K0	1	332001055R1	
U003	C289	C-CERA C	CK725B1A-105K0	1	332001055R1	
U003	C290	C-CERA C	CK725B1A-105K0	1	332001055R1	
U003	C293	C-CERA C	CK725B1H-102K0	1	332031025R1	
U003	C294	C-CERA C	CK725B1H-102K0	1	332031025R1	
U003	C295	C-CERA C	CK725B1H-102K0	1	332031025R1	
U003	C296	C-CERA C	CK725B1H-102K0	1	332031025R1	
U003	C301	C-CERA C	CC725CH1H-180J0	1	342031804R1	

U003	C302	C-CERA C	CC725CH1H-180J0	1	342031804R1	
U003	C305	C-CERA C	CK725B1C-104K0	1	332011045R1	
U003	C306	CHIP ELECT C	CEWX4V-220M	1	3981G2217R2	
U003	C307	C-CERA C	CK725B1C-104K0	1	332011045R1	
U003	C3117	C-CERA C	CK725B1H-102K0	1	332031025R1	
U003	C3118	C-CERA C	CK725B1A-105K0	1	332001055R1	
U003	C312	C-CERA C	CC725CH1H-221J0	1	342032214R1	N
U003	C313	C-CERA C	CK725B1C-104K0	1	332011045R1	
U003	C314	CHIP ELECT C	CEWX4V-220M	1	3981G2217R2	
U003	C315	C-CERA C	CK725B1H-472K0	1	332034725R1	
U003	C316	C-CERA C	CK725B1C-473K0	1	332014735R1	N
U003	C317	C-CERA C	CK725B1C-104K0	1	332011045R1	
U003	C318	CHIP ELECT C	CEWX10V-220M	1	398132217R2	
U003	C319	CHIP ELECT C	CEWX16V-47M	1	398144707R2	
U003	C320	C-CERA C	CK725B1E-223K0	1	332022235R1	N
U003	C351	CHIP ELECT C	CEWX4V-220M	1	3981G2217R2	
U003	C352	C-CERA C	CK725B1C-104K0	1	332011045R1	
U003	C353	CHIP ELECT C	CEWX10V-220M	1	398132217R2	
U003	C354	C-CERA C	CK725B1C-104K0	1	332011045R1	
U003	C355	C-CERA C	CK725B1C-104K0	1	332011045R1	
U003	C356	CHIP ELECT C	CEWX16V-47M	1	398144707R2	
U003	C365	CHIP ELECT C	CEWX50V-10M	1	398181007R2	
U003	C366	CHIP ELECT C	CEWX50V-10M	1	398181007R2	
U003	C367	CHIP ELECT C	CEWX50V-10M	1	398181007R2	
U003	C368	CHIP ELECT C	CEWX50V-10M	1	398181007R2	
U003	C369	CHIP ELECT C	CEWX50V-10M	1	398181007R2	
U003	C370	CHIP ELECT C	CEWX50V-10M	1	398181007R2	
U003	C501	C-CERA C	CK732B16V-106K	1	332071065R2	N
U003	C502	C-CERA C	CK725B1C-104K0	1	332011045R1	
U003	C503	C-CERA C	CK725B1C-104K0	1	332011045R1	
U003	C504	C-CERA C	CK725B1C-104K0	1	332011045R1	
U003	C505	C-CERA C	CK725B1C-104K0	1	332011045R1	
U003	C507	C-CERA C	CK725B1C-104K0	1	332011045R1	
U003	C508	C-CERA C	CK725B1C-104K0	1	332011045R1	
U003	C509	C-CERA C	CK732B16V-106K	1	332071065R2	N
U003	C511	C-CERA C	CK725B1H-102K0	1	332031025R1	
U003	C512	C-CERA C	CK725B1H-102K0	1	332031025R1	
U003	C514	C-CERA C	CK725B1C-104K0	1	332011045R1	
U003	C515	C-CERA C	CK725B1C-104K0	1	332011045R1	

U003	C516	C-CERA C	CK725B1C-104K0	1	332011045R1	
U003	C517	C-CERA C	CK725B1C-104K0	1	332011045R1	
U003	C518	C-CERA C	CK725B1H-102K0	1	332031025R1	
U003	C519	C-CERA C	CK725B1H-102K0	1	332031025R1	
U003	C520	C-CERA C	CK725B1H-102K0	1	332031025R1	
U003	C522	C-CERA C	CK725B1C-104K0	1	332011045R1	
U003	C523	C-CERA C	CK725B1H-102K0	1	332031025R1	
U003	C524	C-CERA C	CK725B1H-102K0	1	332031025R1	
U003	C525	C-CERA C	CK725B1C-104K0	1	332011045R1	
U003	C526	C-CERA C	CK725B1H-102K0	1	332031025R1	
U003	C527	C-CERA C	CK725B1H-102K0	1	332031025R1	
U003	C528	C-CERA C	CK725B1C-104K0	1	332011045R1	
U003	C613	C-CERA C	CK732B1C-474K	1	337394745R1	
U003	C701	C-CERA C	CK732B16V-106K	1	332071065R2	N
U003	C702	C-CERA C	CK732B16V-106K	1	332071065R2	N
U003	C703	C-CERA C	CK732B16V-106K	1	332071065R2	N
U003	C705	C-CERA C	CK732B16V-106K	1	332071065R2	N
U003	C706	C-CERA C	CK725B1E-106K	1	332221065R2	
U003	C707	C-CERA C	CK732B16V-106K	1	332071065R2	N
U003	C708	C-CERA C	CK732B16V-106K	1	332071065R2	N
U003	C709	C-CERA C	CK725B1E-106K	1	332221065R2	
U003	C710	C-CERA C	CK725B1C-104K0	1	332011045R1	
U003	C745	C-CERA C	CK732B16V-106K	1	332071065R2	N
U003	C751	C-CERA C	CK725B1A-105K0	1	332001055R1	
U003	C753	CHIP ELECT C	CEWT6.3V-470M	1	395724717R2	
U003	C8100	C-CERA C	CK725B1H-102K0	1	332031025R1	
U003	C8103	C-CERA C	CK725B1C-104K0	1	332011045R1	
U003	C8104	C-CERA C	CK725B1H-102K0	1	332031025R1	
U003	C8105	C-CERA C	CK725B1C-104K0	1	332011045R1	
U003	C8106	C-CERA C	CK725B1H-102K0	1	332031025R1	
U003	C8107	C-CERA C	CK725B1C-104K0	1	332011045R1	
U003	C8108	C-CERA C	CK725B1H-102K0	1	332031025R1	
U003	C8109	C-CERA C	CK725B1C-104K0	1	332011045R1	
U003	C8110	C-CERA C	CK725B1H-102K0	1	332031025R1	
U003	C8111	C-CERA C	CK725B1C-104K0	1	332011045R1	
U003	C8112	C-CERA C	CK725B1H-102K0	1	332031025R1	
U003	C8113	C-CERA C	CK725B1C-104K0	1	332011045R1	
U003	C8114	C-CERA C	CK725B1H-102K0	1	332031025R1	
U003	C8115	C-CERA C	CK725B1C-104K0	1	332011045R1	

U003	C8116	C-CERA C	CK725B1H-102K0	1	332031025R1	
U003	C8117	C-CERA C	CK725B1H-102K0	1	332031025R1	
U003	C8118	C-CERA C	CK725B1H-102K0	1	332031025R1	
U003	C8119	C-CERA C	CK725B1C-104K0	1	332011045R1	
U003	C8120	C-CERA C	CK725B1H-102K0	1	332031025R1	
U003	C8121	C-CERA C	CK725B1C-104K0	1	332011045R1	
U003	C8122	C-CERA C	CK725B1C-104K0	1	332011045R1	
U003	C8123	CERA C	CC725CH1H-070C0	1	342030701R1	N
U003	C8124	C-CERA C	CK725B1H-102K0	1	332031025R1	
U003	C8125	C-CERA C	CK725B1H-102K0	1	332031025R1	
U003	C8126	C-CERA C	CK725B1C-104K0	1	332011045R1	
U003	C8127	CERA C	CC725CH1H-070C0	1	342030701R1	N
U003	C8128	C-CERA C	CK725B1H-102K0	1	332031025R1	
U003	C8129	C-CERA C	CK725B1C-104K0	1	332011045R1	
U003	C8130	C-CERA C	CK725B1H-102K0	1	332031025R1	
U003	C8131	C-CERA C	CK725B1H-102K0	1	332031025R1	
U003	C8132	C-CERA C	CK725B1H-102K0	1	332031025R1	
U003	C8133	C-CERA C	CK725B1C-104K0	1	332011045R1	
U003	C8134	C-CERA C	CK725B1H-102K0	1	332031025R1	
U003	C8135	C-CERA C	CK725B1C-104K0	1	332011045R1	
U003	C8136	C-CERA C	CK725B1H-102K0	1	332031025R1	
U003	C8137	C-CERA C	CK725B1C-104K0	1	332011045R1	
U003	C8138	C-CERA C	CK725B1H-102K0	1	332031025R1	
U003	C8139	C-CERA C	CK725B1H-102K0	1	332031025R1	
U003	C8140	C-CERA C	CK725B1C-104K0	1	332011045R1	
U003	C8141	C-CERA C	CK725B1H-102K0	1	332031025R1	
U003	C8142	C-CERA C	CK725B1C-104K0	1	332011045R1	
U003	C8143	C-CERA C	CK725B1H-102K0	1	332031025R1	
U003	C8144	C-CERA C	CK725B1H-102K0	1	332031025R1	
U003	C8145	C-CERA C	CK725B1H-102K0	1	332031025R1	
U003	C8146	C-CERA C	CK725B1C-104K0	1	332011045R1	
U003	C8147	C-CERA C	CK725B1H-102K0	1	332031025R1	
U003	C8148	C-CERA C	CK725B1C-104K0	1	332011045R1	
U003	C8149	C-CERA C	CK725B1H-102K0	1	332031025R1	
U003	C8151	C-CERA C	CK725B1C-104K0	1	332011045R1	
U003	C8152	C-CERA C	CK725B1H-102K0	1	332031025R1	
U003	C8153	C-CERA C	CK725B1C-104K0	1	332011045R1	
U003	C8154	C-CERA C	CK725B1H-102K0	1	332031025R1	
U003	C8155	C-CERA C	CK725B1C-104K0	1	332011045R1	

U003	C8156	C-CERA C	CK725B1H-102K0	1	332031025R1	
U003	C8158	C-CERA C	CK725B1C-104K0	1	332011045R1	
U003	C8159	C-CERA C	CK725B1H-102K0	1	332031025R1	
U003	C8160	C-CERA C	CK725B1C-104K0	1	332011045R1	
U003	C8161	C-CERA C	CK725B1H-102K0	1	332031025R1	
U003	C8162	C-CERA C	CK725B1C-104K0	1	332011045R1	
U003	C8163	C-CERA C	CK725B1H-102K0	1	332031025R1	
U003	C8164	C-CERA C	CK725B1C-104K0	1	332011045R1	
U003	C8165	C-CERA C	CK725B1H-102K0	1	332031025R1	
U003	C8166	C-CERA C	CK725B1H-102K0	1	332031025R1	
U003	C8168	C-CERA C	CK725B1H-102K0	1	332031025R1	
U003	C8170	C-CERA C	CK725B1C-104K0	1	332011045R1	
U003	C8175	C-CERA C	CK725B1H-102K0	1	332031025R1	
U003	C8176	C-CERA C	CK725B1A-105K0	1	332001055R1	
U003	C8177	C-CERA C	CK725B1A-105K0	1	332001055R1	
U003	C8911	C-CERA C	CK732B16V-106K	1	332071065R2	N
U003	C8921	C-CERA C	CK732B16V-106K	1	332071065R2	N
U003	C8922	C-CERA C	CK732B16V-106K	1	332071065R2	N
U003	C8926	C-CERA C	CK725B1A-105K0	1	332001055R1	
U003	C8931	C-CERA C	CK725B1E-106K	1	332221065R2	
U003	C8932	C-CERA C	CK725B1E-106K	1	332221065R2	
U003	C8933	C-CERA C	CK732B16V-106K	1	332071065R2	N
U003	C8934	C-CERA C	CK732B16V-106K	1	332071065R2	N
U003	C8935	C-CERA C	CK732B16V-106K	1	332071065R2	N
U003	C8936	CHIP ELECT C	CEWX16V-100M	1	398141017R2	
U003	C8937	C-CERA C	CK725B1C-104K0	1	332011045R1	
U003	C8938	C-CERA C	CK725B1E-223K0	1	332022235R1	N
U003	C8939	C-CERA C	CK725B1C-104K0	1	332011045R1	
U003	C8940	C-CERA C	CK725B1E-103K0	1	332021035R1	
U003	C8943	C-CERA C	CC725CH1H-151J0	1	342031514R1	N
U003	C8950	CHIP ELECT C	CEWX16V-100M	1	398141017R2	
U003	C8951	C-CERA C	CK725B1E-106K	1	332221065R2	
U003	C8952	C-CERA C	CK725B1E-106K	1	332221065R2	
U003	C8953	C-CERA C	CK732B16V-106K	1	332071065R2	N
U003	C8954	C-CERA C	CK732B16V-106K	1	332071065R2	N
U003	C8955	C-CERA C	CK732B16V-106K	1	332071065R2	N
U003	C8956	CHIP ELECT C	CEWX16V-100M	1	398141017R2	
U003	C8957	C-CERA C	CK725B1C-104K0	1	332011045R1	
U003	C8958	C-CERA C	CK725B1E-223K0	1	332022235R1	N

U003	C8959	C-CERA C	CK725B1C-104K0	1	332011045R1	
U003	C8960	C-CERA C	CK725B1E-103K0	1	332021035R1	
U003	C8963	C-CERA C	CC725CH1H-151J0	1	342031514R1	N
U003	C8971	C-CERA C	CK725B1E-106K	1	332221065R2	
U003	C8972	C-CERA C	CK725B1E-106K	1	332221065R2	
U003	C8973	C-CERA C	CK732B16V-106K	1	332071065R2	N
U003	C8974	C-CERA C	CK732B16V-106K	1	332071065R2	N
U003	C8975	C-CERA C	CK732B16V-106K	1	332071065R2	N
U003	C8976	CHIP ELECT C	CEWX16V-100M	1	398141017R2	
U003	C8977	C-CERA C	CK725B1C-104K0	1	332011045R1	
U003	C8978	C-CERA C	CK725B1E-223K0	1	332022235R1	N
U003	C8979	C-CERA C	CK725B1C-104K0	1	332011045R1	
U003	C8980	C-CERA C	CK725B1E-682K0	1	332026825R1	N
U003	C8983	C-CERA C	CK725B1A-105K0	1	332001055R1	
U003	C8984	C-CERA C	CK725B1A-105K0	1	332001055R1	
U003	C8985	C-CERA C	CK725B1A-105K0	1	332001055R1	
U003	C8986	C-CERA C	CK725B1A-105K0	1	332001055R1	
U003	C8987	C-CERA C	CK725B1A-105K0	1	332001055R1	
U003	C8988	C-CERA C	CK725B1A-105K0	1	332001055R1	
U003	[RESISTOR]					
U003	R110	C-CARBON R	RN72K1J-103JE	1	435031034R1	
U003	R151	C-CARBON R	RN72K1J-103JE	1	435031034R1	
U003	R152	C-CARBON R	RN72K1J-103JE	1	435031034R1	
U003	R154	C-CARBON R	RN72K1J-103JE	1	435031034R1	
U003	R201	C-CARBON R	RN72K1J-103JE	1	435031034R1	
U003	R202	C-CARBON R	RN72K1J-103JE	1	435031034R1	
U003	R203	C-CARBON R	RN72K1J-103JE	1	435031034R1	
U003	R204	C-CARBON R	RN72K1J-472JE	1	435034724R1	
U003	R205	C-CARBON R	RN72K1J-221JE	1	435032214R1	
U003	R206	C-CARBON R	RN72K1J-470JE	1	435034704R1	
U003	R207	C-CARBON R	RN72K1J-470JE	1	435034704R1	
U003	R208	C-CARBON R	RN72K1J-470JE	1	435034704R1	
U003	R209	C-CARBON R	RN72K1J-470JE	1	435034704R1	
U003	R210	C-CARBON R	RN72K1J-470JE	1	435034704R1	
U003	R211	C-CARBON R	RN72K1J-470JE	1	435034704R1	
U003	R212	C-CARBON R	RN72K1J-103JE	1	435031034R1	
U003	R213	C-CARBON R	RN72K1J-103JE	1	435031034R1	
U003	R214	C-CARBON R	RN72K1J-331JE	1	435033314R1	
U003	R215	C-CARBON R	RN72K1J-103JE	1	435031034R1	

U003	R216	C-CARBON R	RN72K1J-470JE	1	435034704R1
U003	R220	C-R NET	RM7LJ330X04	1	43484733004R2
U003	R221	C-R NET	RM7LJ330X04	1	43484733004R2
U003	R222	C-R NET	RM7LJ330X04	1	43484733004R2
U003	R223	C-R NET	RM7LJ330X04	1	43484733004R2
U003	R224	C-R NET	RM7LJ330X04	1	43484733004R2
U003	R225	C-R NET	RM7LJ330X04	1	43484733004R2
U003	R226	C-R NET	RM7LJ330X04	1	43484733004R2
U003	R227	C-R NET	RM7LJ330X04	1	43484733004R2
U003	R228	C-R NET	RM7LJ330X04	1	43484733004R2
U003	R229	C-R NET	RM7LJ330X04	1	43484733004R2
U003	R230	C-CARBON R	RN72K1J-330JE	1	435033304R1
U003	R231	C-CARBON R	RN72K1J-103JE	1	435031034R1
U003	R232	C-CARBON R	RN72K1J-103JE	1	435031034R1
U003	R235	C-CARBON R	RN72K1J-470JE	1	435034704R1
U003	R236	C-CARBON R	RN72K1J-470JE	1	435034704R1
U003	R237	C-CARBON R	RN72K1J-470JE	1	435034704R1
U003	R238	C-CARBON R	RN72K1J-331JE	1	435033314R1
U003	R239	C-CARBON R	RN72K1J-331JE	1	435033314R1
U003	R240	C-CARBON R	RN72K1J-331JE	1	435033314R1
U003	R241	C-CARBON R	RN72K1J-331JE	1	435033314R1
U003	R242	C-CARBON R	RN72K1J-470JE	1	435034704R1
U003	R243	C-CARBON R	RN72K1J-331JE	1	435033314R1
U003	R244	C-CARBON R	RN72K1J-221JE	1	435032214R1
U003	R245	C-CARBON R	RN72K1J-470JE	1	435034704R1
U003	R246	C-CARBON R	RN72K1J-470JE	1	435034704R1
U003	R247	C-CARBON R	RN72K1J-103JE	1	435031034R1
U003	R248	C-CARBON R	RN72K1J-331JE	1	435033314R1
U003	R249	C-CARBON R	RN72K1J-331JE	1	435033314R1
U003	R252	C-CARBON R	RN72K1J-000JE	1	435030004R1
U003	R253	C-CARBON R	RN72K1J-221JE	1	435032214R1
U003	R254	C-CARBON R	RN72K1J-103JE	1	435031034R1
U003	R255	C-CARBON R	RN72K1J-221JE	1	435032214R1
U003	R256	C-CARBON R	RN72K1J-470JE	1	435034704R1
U003	R257	C-CARBON R	RN72K1J-470JE	1	435034704R1
U003	R262	C-CARBON R	RN72K1J-103JE	1	435031034R1
U003	R263	C-CARBON R	RN72K1J-103JE	1	435031034R1
U003	R264	C-CARBON R	RN72K1J-103JE	1	435031034R1
U003	R265	C-CARBON R	RN72K1J-221JE	1	435032214R1

U003	R271	C-CARBON R	RN72K1J-000JE	1	435030004R1
U003	R272	C-CARBON R	RN72K1J-000JE	1	435030004R1
U003	R273	C-CARBON R	RN72K1J-000JE	1	435030004R1
U003	R276	C-CARBON R	RN72K1J-473JE	1	435034734R1
U003	R277	C-CARBON R	RN72K1J-222JE	1	435032224R1
U003	R281	C-CARBON R	RN72K1J-103JE	1	435031034R1
U003	R282	C-CARBON R	RN72K1J-103JE	1	435031034R1
U003	R284	C-CARBON R	RN72K1J-103JE	1	435031034R1
U003	R301	C-CARBON R	RN72K1J-470JE	1	435034704R1
U003	R304	C-CARBON R	RN72K1J-221JE	1	435032214R1
U003	R305	C-CARBON R	RN72K1J-221JE	1	435032214R1
U003	R306	C-CARBON R	RN72K1J-330JE	1	435033304R1
U003	R307	C-CARBON R	RN72K1J-331JE	1	435033314R1
U003	R308	C-CARBON R	RN72K1J-331JE	1	435033314R1
U003	R312	C-CARBON R	RN72K1J-470JE	1	435034704R1
U003	R313	C-CARBON R	RN72K1J-470JE	1	435034704R1
U003	R314	C-CARBON R	RN72K1J-151JE	1	435031514R1
U003	R315	C-CARBON R	RN72K1J-470JE	1	435034704R1
U003	R316	C-CARBON R	RN72K1J-470JE	1	435034704R1
U003	R317	C-CARBON R	RN72K1J-331JE	1	435033314R1
U003	R321	C-CARBON R	RN72K1J-331JE	1	435033314R1
U003	R322	C-CARBON R	RN72K1J-331JE	1	435033314R1
U003	R324	C-CARBON R	RN72K1J-331JE	1	435033314R1
U003	R325	C-CARBON R	RN72K1J-331JE	1	435033314R1
U003	R326	C-CARBON R	RN72K1J-331JE	1	435033314R1
U003	R327	C-CARBON R	RN72K1J-221JE	1	435032214R1
U003	R331	C-CARBON R	RN72K1J-221JE	1	435032214R1
U003	R332	C-CARBON R	RN72K1J-681JE	1	435036814R1
U003	R333	C-CARBON R	RN72K1J-221JE	1	435032214R1
U003	R351	C-CARBON R	RN72K1J-331JE	1	435033314R1
U003	R352	C-CARBON R	RN72K1J-331JE	1	435033314R1
U003	R354	C-CARBON R	RN72K1J-470JE	1	435034704R1
U003	R355	C-CARBON R	RN72K1J-220JE	1	435032204R1
U003	R356	C-CARBON R	RN72K1J-220JE	1	435032204R1
U003	R357	C-CARBON R	RN72K1J-220JE	1	435032204R1
U003	R359	C-CARBON R	RN72K1J-220JE	1	435032204R1
U003	R360	C-CARBON R	RN72K1J-220JE	1	435032204R1
U003	R361	C-CARBON R	RN72K1J-331JE	1	435033314R1
U003	R362	C-CARBON R	RN72K1J-000JE	1	435030004R1

U003	R365	C-CARBON R	RN72K1J-104JE	1	435031044R1
U003	R366	C-CARBON R	RN72K1J-104JE	1	435031044R1
U003	R367	C-CARBON R	RN72K1J-104JE	1	435031044R1
U003	R368	C-CARBON R	RN72K1J-104JE	1	435031044R1
U003	R369	C-CARBON R	RN72K1J-104JE	1	435031044R1
U003	R370	C-CARBON R	RN72K1J-104JE	1	435031044R1
U003	R501	C-CARBON R	RN72K1J-473JE	1	435034734R1
U003	R503	C-CARBON R	RN72K1J-103JE	1	435031034R1
U003	R504	C-CARBON R	RN72K1J-000JE	1	435030004R1
U003	R505	C-CARBON R	RN72K1J-103JE	1	435031034R1
U003	R508	C-CARBON R	RN72K1J-105JE	1	435031054R1
U003	R509	C-CARBON R	RN72K1J-221JE	1	435032214R1
U003	R510	C-CARBON R	RN72K1J-470JE	1	435034704R1
U003	R511	C-CARBON R	RN72K1J-103JE	1	435031034R1
U003	R512	C-CARBON R	RN72K1J-221JE	1	435032214R1
U003	R514	C-CARBON R	RN72K1J-221JE	1	435032214R1
U003	R515	C-R NET	RM7LJ470X04	1	43484747004R2
U003	R520	C-CARBON R	RN72K1J-103JE	1	435031034R1
U003	R521	C-R NET	RM7LJ470X04	1	43484747004R2
U003	R532	C-CARBON R	RN72K1J-472JE	1	435034724R1
U003	R533	C-CARBON R	RN72K1J-472JE	1	435034724R1
U003	R534	C-R NET	RM7LJ103X04	1	43484710304R2
U003	R538	C-CARBON R	RN72K1J-103JE	1	435031034R1
U003	R539	C-R NET	RM7LJ470X04	1	43484747004R2
U003	R543	C-CARBON R	RN72K1J-103JE	1	435031034R1
U003	R544	C-R NET	RM7LJ221X04	1	43484722104R2
U003	R550	C-R NET	RM7LJ470X04	1	43484747004R2
U003	R551	C-CARBON R	RN72K1J-103JE	1	435031034R1
U003	R552	C-CARBON R	RN72K1J-103JE	1	435031034R1
U003	R554	C-CARBON R	RN72K1J-103JE	1	435031034R1
U003	R560	C-CARBON R	RN72K1J-103JE	1	435031034R1
U003	R562	C-CARBON R	RN72K1J-221JE	1	435032214R1
U003	R565	C-R NET	RM7LJ470X04	1	43484747004R2
U003	R566	C-CARBON R	RN72K1J-103JE	1	435031034R1
U003	R568	C-CARBON R	RN72K1J-103JE	1	435031034R1
U003	R570	C-CARBON R	RN72K1J-103JE	1	435031034R1
U003	R572	C-CARBON R	RN72K1J-103JE	1	435031034R1
U003	R573	C-CARBON R	RN72K1J-221JE	1	435032214R1
U003	R574	C-R NET	RM7LJ470X04	1	43484747004R2

U003	R577	C-CARBON R	RN72K1J-103JE	1	435031034R1
U003	R579	C-CARBON R	RN72K1J-470JE	1	435034704R1
U003	R580	C-R NET	RM7LJ103X04	1	43484710304R2
U003	R582	C-R NET	RM7LJ221X04	1	43484722104R2
U003	R590	C-CARBON R	RN72K1J-103JE	1	435031034R1
U003	R595	C-R NET	RM7LJ221X04	1	43484722104R2
U003	R596	C-CARBON R	RN72K1J-103JE	1	435031034R1
U003	R599	C-R NET	RM7LJ103X04	1	43484710304R2
U003	R601	C-R NET	RM7LJ470X04	1	43484747004R2
U003	R605	C-CARBON R	RN72K1J-221JE	1	435032214R1
U003	R606	C-CARBON R	RN72K1J-470JE	1	435034704R1
U003	R607	C-CARBON R	RN72K1J-221JE	1	435032214R1
U003	R609	C-CARBON R	RN72K1J-102JE	1	435031024R1
U003	R610	C-CARBON R	RN72K1J-221JE	1	435032214R1
U003	R611	C-CARBON R	RN72K1J-102JE	1	435031024R1
U003	R613	C-CARBON R	RN72K1J-102JE	1	435031024R1
U003	R614	C-CARBON R	RN72K1J-103JE	1	435031034R1
U003	R617	C-CARBON R	RN72K1J-221JE	1	435032214R1
U003	R618	C-CARBON R	RN72K1J-103JE	1	435031034R1
U003	R619	C-CARBON R	RN72K1J-470JE	1	435034704R1
U003	R620	C-CARBON R	RN72K1J-103JE	1	435031034R1
U003	R621	C-CARBON R	RN72K1J-221JE	1	435032214R1
U003	R622	C-CARBON R	RN72K1J-470JE	1	435034704R1
U003	R623	C-CARBON R	RN72K1J-103JE	1	435031034R1
U003	R624	C-CARBON R	RN72K1J-221JE	1	435032214R1
U003	R625	C-CARBON R	RN72K1J-470JE	1	435034704R1
U003	R627	C-CARBON R	RN72K1J-103JE	1	435031034R1
U003	R631	C-CARBON R	RN72K1J-470JE	1	435034704R1
U003	R633	C-CARBON R	RN72K1J-103JE	1	435031034R1
U003	R635	C-CARBON R	RN72K1J-103JE	1	435031034R1
U003	R638	C-CARBON R	RN72K1J-470JE	1	435034704R1
U003	R639	C-CARBON R	RN72K1J-103JE	1	435031034R1
U003	R640	C-CARBON R	RN72K1J-470JE	1	435034704R1
U003	R642	C-CARBON R	RN72K1J-221JE	1	435032214R1
U003	R644	C-CARBON R	RN72K1J-221JE	1	435032214R1
U003	R646	C-CARBON R	RN72K1J-221JE	1	435032214R1
U003	R650	C-CARBON R	RN72K1J-221JE	1	435032214R1
U003	R651	C-CARBON R	RN72K1J-103JE	1	435031034R1
U003	R652	C-CARBON R	RN72K1J-102JE	1	435031024R1

U003	R653	C-CARBON R	RN72K1J-105JE	1	435031054R1
U003	R655	C-CARBON R	RN72K1J-223JE	1	435032234R1
U003	R656	C-CARBON R	RN72K1J-223JE	1	435032234R1
U003	R657	C-CARBON R	RN72K1J-224JE	1	435032244R1
U003	R658	C-CARBON R	RN72K1J-221JE	1	435032214R1
U003	R659	C-CARBON R	RN72K1J-273JE	1	435032734R1
U003	R660	C-CARBON R	RN72K1J-221JE	1	435032214R1
U003	R661	C-CARBON R	RN72K1J-221JE	1	435032214R1
U003	R662	C-CARBON R	RN72K1J-333JE	1	435033334R1
U003	R663	C-CARBON R	RN72K1J-103JE	1	435031034R1
U003	R664	C-CARBON R	RN72K1J-103JE	1	435031034R1
U003	R665	C-CARBON R	RN72K1J-333JE	1	435033334R1
U003	R666	C-CARBON R	RN72K1J-000JE	1	435030004R1
U003	R669	C-CARBON R	RN72K1J-103JE	1	435031034R1
U003	R670	C-CARBON R	RN72K1J-472JE	1	435034724R1
U003	R671	C-CARBON R	RN72K1J-272JE	1	435032724R1
U003	R672	C-CARBON R	RN72K1J-472JE	1	435034724R1
U003	R673	C-CARBON R	RN72K1J-272JE	1	435032724R1
U003	R674	C-CARBON R	RN72K1J-472JE	1	435034724R1
U003	R675	C-CARBON R	RN72K1J-272JE	1	435032724R1
U003	R676	C-CARBON R	RN72K1J-472JE	1	435034724R1
U003	R677	C-CARBON R	RN72K1J-272JE	1	435032724R1
U003	R678	C-CARBON R	RN72K1J-224JE	1	435032244R1
U003	R681	C-CARBON R	RN72K1J-103JE	1	435031034R1
U003	R682	C-CARBON R	RN72K1J-103JE	1	435031034R1
U003	R687	C-CARBON R	RN72K1J-103JE	1	435031034R1
U003	R688	C-R NET	RM7LJ103X04	1	43484710304R2
U003	R690	C-R NET	RM7LJ470X04	1	43484747004R2
U003	R692	C-R NET	RM7LJ472X04	1	43484747204R2
U003	R693	C-R NET	RM7LJ470X04	1	43484747004R2
U003	R701	C-CARBON R	RN72K1J-000JE	1	435030004R1
U003	R712	C-CARBON R	RN72K1J-102JE	1	435031024R1
U003	R713	C-CARBON R	RN72K1J-222JE	1	435032224R1
U003	R714	C-CARBON R	RN72K1J-103JE	1	435031034R1
U003	R715	C-CARBON R	RN72K1J-103JE	1	435031034R1
U003	R716	C-CARBON R	RN72K1J-470JE	1	435034704R1
U003	R723	C-CARBON R	RN72K1J-101JE	1	435031014R1
U003	R724	C-CARBON R	RN72K1J-101JE	1	435031014R1
U003	R725	C-CARBON R	RN72K1J-221JE	1	435032214R1

U003	R726	C-CARBON R	RN72K1J-273JE	1	435032734R1
U003	R727	C-CARBON R	RN72K1J-103JE	1	435031034R1
U003	R803	C-CARBON R	RN72K1J-000JE	1	435030004R1
U003	R8100	C-CARBON R	RN72K1J-102JE	1	435031024R1
U003	R8101	C-CARBON R	RN72K1J-000JE	1	435030004R1
U003	R8102	C-CARBON R	RN72K1J-473JE	1	435034734R1
U003	R8118	C-CARBON R	RN72K1J-102JE	1	435031024R1
U003	R8119	C-CARBON R	RN72K1J-102JE	1	435031024R1
U003	R8120	C-CARBON R	RN72K1J-000JE	1	435030004R1
U003	R8121	C-CARBON R	RN72K1J-102JE	1	435031024R1
U003	R8122	C-CARBON R	RN72K1J-473JE	1	435034734R1
U003	R8125	C-CARBON R	RN72K1J-101JE	1	435031014R1
U003	R8126	C-CARBON R	RN72K1J-101JE	1	435031014R1
U003	R8127	C-CARBON R	RN72K1J-330JE	1	435033304R1
U003	R8128	C-CARBON R	RN72K1J-331JE	1	435033314R1
U003	R8129	C-CARBON R	RN72K1J-330JE	1	435033304R1
U003	R8131	C-R NET	RM7LJ330X04	1	43484733004R2
U003	R8132	C-R NET	RM7LJ101X04	1	43484710104R2
U003	R8136	C-CARBON R	RN72K1J-102JE	1	435031024R1
U003	R8138	C-CARBON R	RN72K1J-000JE	1	435030004R1
U003	R8140	C-CARBON R	RN72K1J-473JE	1	435034734R1
U003	R8142	C-CARBON R	RN72K1J-220JE	1	435032204R1
U003	R8148	C-CARBON R	RN72K1J-473JE	1	435034734R1
U003	R8150	C-R NET	RM7LJ470X04	1	43484747004R2
U003	R8154	C-R NET	RM7LJ220X04	1	43484722004R2
U003	R8158	C-CARBON R	RN72K1J-473JE	1	435034734R1
U003	R8159	C-CARBON R	RN72K1J-182JE	1	435031824R1
U003	R8160	C-CARBON R	RN72K1J-182JE	1	435031824R1
U003	R8161	C-CARBON R	RN72K1J-821FE	1	435038212R1
U003	R8162	C-CARBON R	RN72K1J-680JE	1	435036804R1
U003	R8166	C-CARBON R	RN72K1J-102JE	1	435031024R1
U003	R8167	C-CARBON R	RN72K1J-000JE	1	435030004R1
U003	R8169	C-CARBON R	RN72K1J-473JE	1	435034734R1
U003	R8172	C-CARBON R	RN72K1J-103JE	1	435031034R1
U003	R8177	C-CARBON R	RN72K1J-101JE	1	435031014R1
U003	R8178	C-CARBON R	RN72K1J-101JE	1	435031014R1
U003	R8179	C-CARBON R	RN72K1J-101JE	1	435031014R1
U003	R8180	C-CARBON R	RN72K1J-101JE	1	435031014R1
U003	R8181	C-CARBON R	RN72K1J-100JE	1	435031004R1

U003	R8182	C-CARBON R	RN72K1J-100JE	1	435031004R1	
U003	R8191	C-CARBON R	RN72K1J-103JE	1	435031034R1	
U003	R8192	C-CARBON R	RN72K1J-103JE	1	435031034R1	
U003	R8193	C-CARBON R	RN72K1J-103JE	1	435031034R1	
U003	R8194	C-CARBON R	RN72K1J-103JE	1	435031034R1	
U003	R8933	C-CARBON R	RN72K1J-563FE	1	435035632R1	
U003	R8934	C-CARBON R	RN72K1J-274JE	1	435032744R1	
U003	R8935	C-CARBON R	RN72K1J-103FE	1	435031032R1	
U003	R8936	C-CARBON R	RN72K1J-822JE	1	435038224R1	
U003	R8951	C-CARBON R	RN72K1J-103JE	1	435031034R1	
U003	R8953	C-CARBON R	RN72K1J-273FE	1	435032732R1	
U003	R8955	C-CARBON R	RN72K1J-103FE	1	435031032R1	
U003	R8956	C-CARBON R	RN72K1J-562JE	1	435035624R1	
U003	R8971	C-CARBON R	RN72K1J-102JE	1	435031024R1	
U003	R8973	C-CARBON R	RN72K1J-103FE	1	435031032R1	
U003	R8975	C-CARBON R	RN72K1J-103FE	1	435031032R1	
U003	R8976	C-CARBON R	RN72K1J-332JE	1	435033324R1	
U003	[SW TRM]					
U003	JL501B	WIRE TRAP	NPLG-3P586	1	25055624	
U003	JL801B	WIRE TRAP	NPLG-5P588	1	25055626	
U003	JL901B	WIRE TRAP	NPLG-5P588	1	25055626	
U003	P2800B	SOCKET	IMSA-9618S-09A	1	25053334R2	
U003	P2800Bor	SOCKET	09FMN-SMT-A-TF	(1)	25052826R2	
U003	P281	SOCKET	NSCT-8P2471	1	25052574R2	
U003	P3101A	PLUG	NPLG-5P918	1	25055965R2	
U003	P701A	SOCKET	IMSA-9618S-23A	1	25053348R2	N
U003	P701Aor	SOCKET	23FMN-SMT-A-TF	(1)	25052840R2	
U003	P751A	SOCKET	IMSA-9618S-09A	1	25053334R2	
U003	P751Aor	SOCKET	09FMN-SMT-A-TF	(1)	25052826R2	
U003	P752A	SOCKET	NSCT-9P2472	1	25052575R2	
U003	P8001B	SOCKET	IMSA-9618S-21A	1	25053346R2	N
U003	P8001Bor	SOCKET	21FMN-SMT-A-TF	(1)	25052838R2	
U003	P8002B	SOCKET	IMSA-9618S-09A	1	25053334R2	
U003	P8002Bor	SOCKET	09FMN-SMT-A-TF	(1)	25052826R2	
U003	P8003A	SOCKET	NSCT-7P2187	1	25052290	
U003	P8101	SOCKET	TCX3400-111387	1	25053406R3	
U003	P8101 or	SOCKET	YKF45-7037V	(1)	25053253R3	
U003	P8101 or	SOCKET	HDMI(47266-4101)	(1)	25053389R3	
U003	P8101 or	SOCKET	061-043-079	(1)	25053407R3	

U003	P8102	SOCKET	TCX3400-111387	1	25053406R3	N
U003	P8102 or	SOCKET	YKF45-7037V	(1)	25053253R3	
U003	P8102 or	SOCKET	HDMI(47266-4101)	(1)	25053389R3	
U003	P8102 or	SOCKET	061-043-079	(1)	25053407R3	N
U003	P8103	SOCKET	TCX3400-111387	1	25053406R3	N
U003	P8103 or	SOCKET	YKF45-7037V	(1)	25053253R3	
U003	P8103 or	SOCKET	HDMI(47266-4101)	(1)	25053389R3	
U003	P8103 or	SOCKET	061-043-079	(1)	25053407R3	N
U003	P8104	SOCKET	TCX3400-111387	1	25053406R3	N
U003	P8104 or	SOCKET	YKF45-7037V	(1)	25053253R3	
U003	P8104 or	SOCKET	HDMI(47266-4101)	(1)	25053389R3	
U003	P8104 or	SOCKET	061-043-079	(1)	25053407R3	N
U003	P8105	SOCKET	TCX3400-111387	1	25053406R3	N
U003	P8105 or	SOCKET	YKF45-7037V	(1)	25053253R3	
U003	P8105 or	SOCKET	HDMI(47266-4101)	(1)	25053389R3	
U003	P8105 or	SOCKET	061-043-079	(1)	25053407R3	N
U003	P8901	SOCKET	NSCT-8P2471	1	25052574R2	

ONKYO®**ONKYO SOUND & VISION CORPORATION**

Technical Support, Service Dept.: 2-1, Nisshin-cho, Neyagawa-shi, OSAKA 572-8540, JAPAN
Tel: 072-831-8023 Fax: 072-831-8163

ONKYO U.S.A. CORPORATION

18 Park Way, Upper Saddle River, N.J. 07458, U.S.A.
Tel: 800-229-1687, 201-785-2600 Fax: 201-785-2650 <http://www.us.onkyo.com/>

ONKYO EUROPE ELECTRONICS GmbH

Liegnitzerstrasse 6, 82194 Groebenzell, GERMANY
Tel: +49-8142-4401-0 Fax: +49-8142-4401-555 <http://www.eu.onkyo.com/>

ONKYO EUROPE ELECTRONICS GmbH (UK BRANCH)

The Coach House 81A High Street, Marlow, Buckinghamshire, SL7 1AB, UK
Tel: +44-(0)1628-473-350 Fax: +44-(0)1628-401-700

ONKYO CHINA LIMITED

Unit 1&12, 9/F, Ever Gain Plaza Tower 1, 88, Container Port Road, Kwai Chung,
N.T., Hong Kong. Tel: 852-2429-3118 Fax: 852-2428-9039
<http://www.ch.onkyo.com/>