

Zenith Radio Corp.

Model: 5R337

Chassis:

Year: Pre October 1938

Power:

Circuit:

IF:

Tubes:

Bands:

Resources

Riders Volume 9 - ZENITH 9-7

Riders Volume 9 - ZENITH 9-8

ZENITH RADIO CORP.

MODELS 5R312, 5R316, 5R317
5R337, 5R303

Chassis 5528
Schematic, Parts

FOR TUNER DATA, SEE SPECIAL SECTION

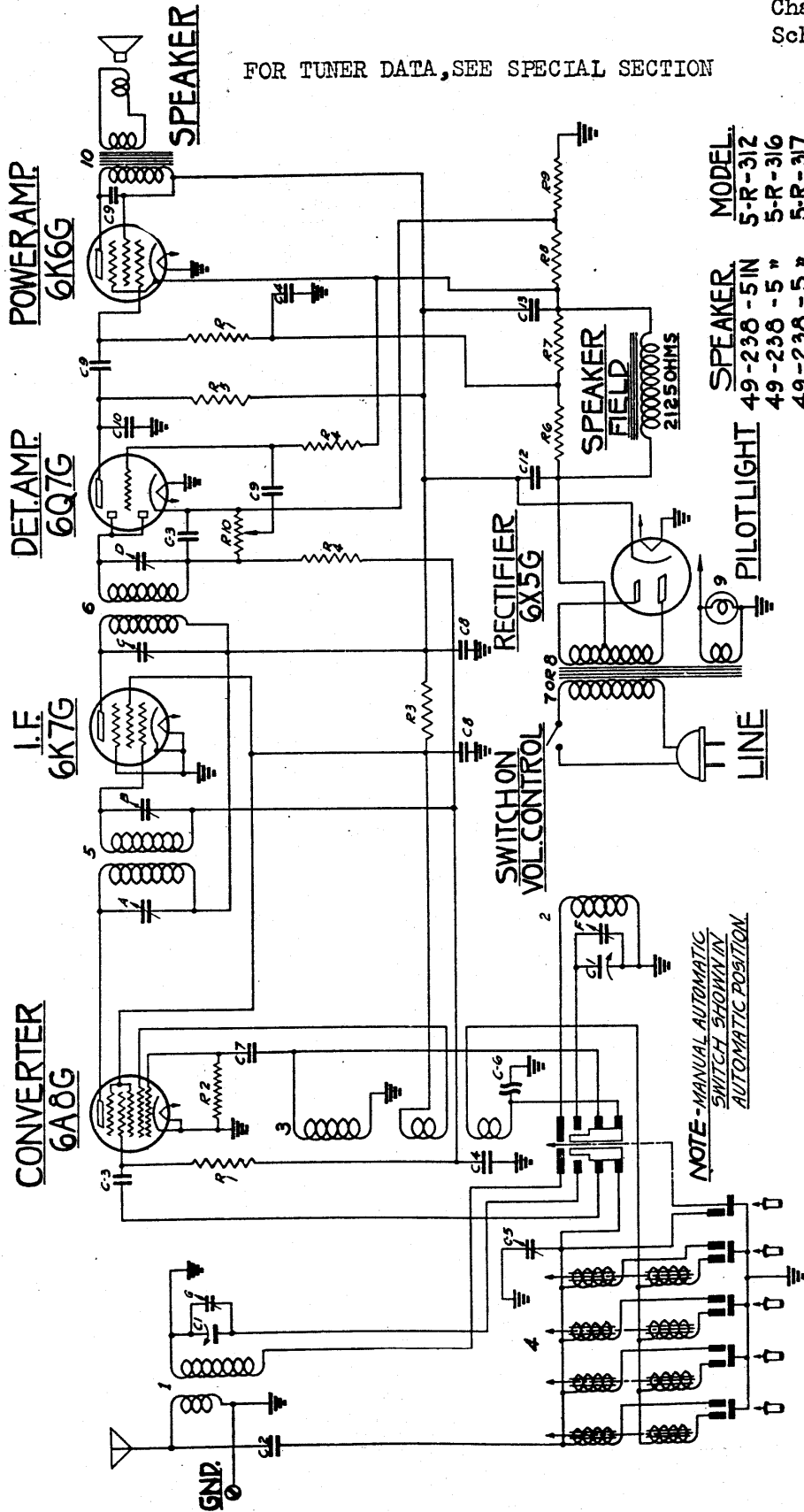

SPEAKER	MODEL
49-238 - 5"	5-R-312
49-238 - 5 "	5-R-316
49-238 - 5 "	5-R-317
49-238 - 5 *	5-R-337
49-238 - 5 *	5-R-303

I.F. FREQUENCY 455 K.C.
5 TUBE SUPERHETERODYNE
CHASSIS N° 5528 A.C.
ZENITH RADIO CORPORATION
CHICAGO, ILL.

PART NO.	DESCRIPTION	PART NO.	DESCRIPTION	DIAG. NO.	DESCRIPTION
C-1 22-695	750 GANG VAR. COND.	R-1 25-597	470 M OHM	4	1ST I.F. TRANS.
C-2 22-289	50 M MFD	R-2 25-593	47 M OHM	5	2ND I.F. TRANS.
C-3 22-162	.0001 MFD	R-3 25-208	12 M OHM	6	2ND I.F. TRANS. (100K. 50-60~)
C-4 22-250	.05 MFD	R-4 25-271	1 MEG OHM	7	POWER TRANS. 25~
C-5 22-519	TRIMMER COND.	R-5 25-296	220 M OHM	8	POWER TRANS. 25~
C-6 22-729	COMPENSATING COND.	R-6 25-650	390 M OHM	9	PILOT LIGHT .25A 6.3V
C-7 22-112	.0025 MFD.	R-7 25-260	100 M OHM	10	5 TRANS. P TRANS
C-8 22-212	.05 MFD.	R-8 25-573	80 OHM WIRE WOUND	A	1ST I.F. TRANS. PRI.
C-9 22-198	.01 MFD.	R-9 25-606	150 OHM WIRE WOUND	B	1ST I.F. TRANS. SEC.
C-10 22-147	.0005 MFD	R-10 25-955	220 M OHM VAR. COND.	C	2ND I.F. TRANS. PRI
C-11 22-691	8 MFD ELECTROLYTIC	5-2008	ANTENNA COIL ASSEMB.	D	2ND I.F. TRANS. SEC.
C-12 22-692	8 MFD ELECTROLYTIC	5-6039	OSC. COIL ASSEMB.	E	BROADCAST OSC. (20K. 45K)
		20-127	COMPENSATING COIL	F	ANTENNA. BRD. CABT. (10/6/MS)

NOTE - MANUAL AUTOMATIC SWITCH SHOWN IN AUTOMATIC POSITION.

MODELS 5R303, 5R312, 5R316
5R317, 5R337

Chassis 5528
Socket, Trimmers, Voltage
Alignment

ZENITH RADIO CORP.

SOCKET
VOLTAGES

NOTE

Voltages measured with a 1000 ohm per volt meter from chassis to socket contacts. Antenna disconnected — volume control on full.

Line voltage 115 v. Consumption 45 watts.

Power output 3.5 watts.

(A) Bias for 6A8 — 6K7 and diodes of 6Q7 measured across resistor R9.

(B) Bias for triode section of 6Q7 and 6K6 measured across R8 and R9.

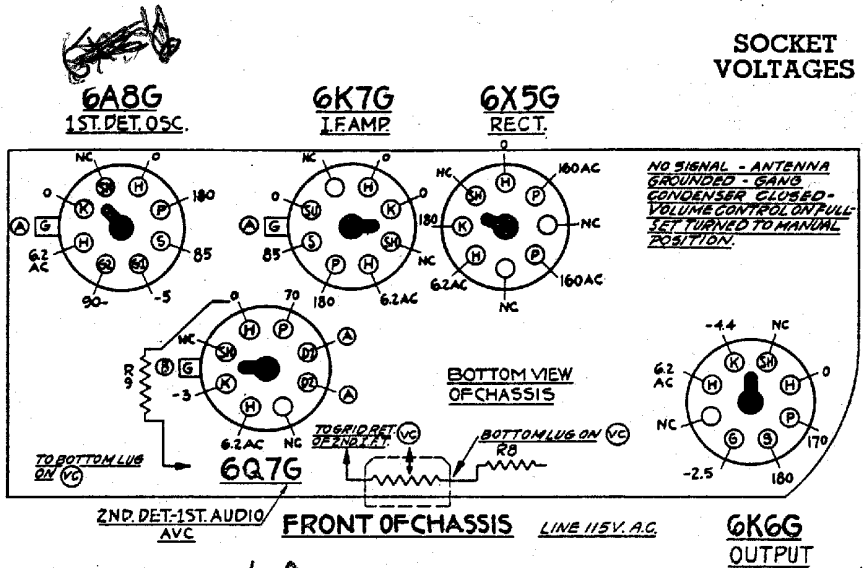

6K6G

LEGEND

- NC — No Connection
- VC — Volume Control
- SH — Shield
- H — Heater
- P — Plate
- S — Screen
- G — Grid
- SU — Suppressor
- D — Diode
- K — Cathode
- F — Filament

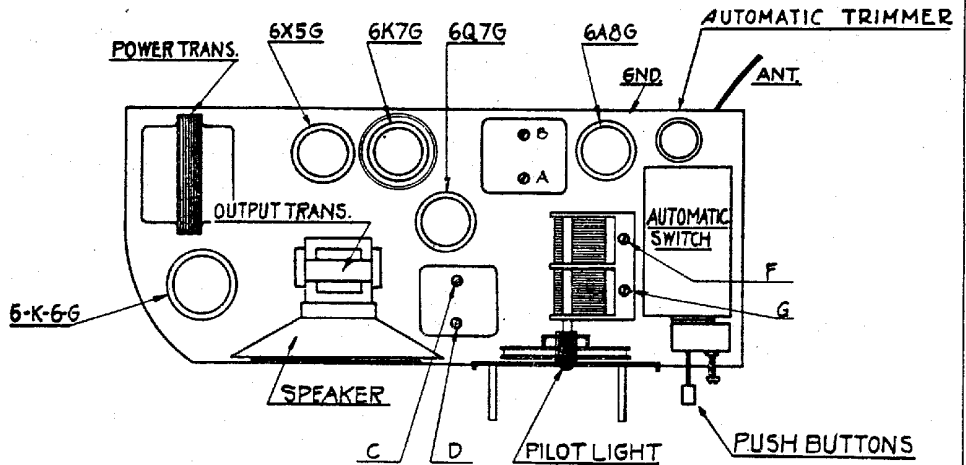

Location of Tubes and Trimmers

Models 5R303, 5R312, 5R316, 5R317, 5R337

CHASSIS No. 5528

ALIGNMENT PROCEDURE

Operation	Connect Test Oscillator to	Dummy Antenna	Set Test Osc. to	Band	Set Dial At	Adjust Trimmers	Purpose
1	1st Det. Grid	1/2 Mfd.	455	Br'dc't	600	ABCD	I. F. Alignment
2	Rec. Ant. Lead	200 Mmfd.	1500	"	1500	F	Set Osc. to Scale
3	" " "	200 Mmfd.	1500	"	1500	G	Al'gment of Ant.