

MODEL LDC-824 • LDC-824S
DIGITAL COUNTER

INSTRUCTION MANUAL



LEADER ELECTRONICS CORP.

LDC-824·LDC-824S
DIGITAL COUNTER

1. Introduction

LDC-824(S) is a digital frequency counter/timer designed to measure the frequency and period of a signal, featuring a wide frequency range (10Hz–520MHz), a high input sensitivity (20mV rms), and high resolution to 8 digits. The period function makes the unit outstanding for video tape recorder service applications. This instrument can be used for adjustment, test and repair of audio instruments, AM/FM radios, TVs, CB radios, computer clocks, amateur-radios, electronic watches, musical instruments, etc. The LDC-824(S) is small and portable. A big bright fluorescent display assures easy readability of values. The green display does not induce eye fatigue even after an extended period of viewing. Readout miscounts are reduced by zero-blanking, unit-display (kHz, MHz, ms) and overrange display. The use of LSI and MSI in the internal circuit assures reliable performance and less power consumption.

2. Specifications

Frequency Measurements

| | |
|------------|--|
| Range | 10Hz – 80MHz (direct), 50MHz – 520MHz (pre-scaler) |
| Gate time | 0.1s, 1s, 10s |
| Resolution | 10Hz, 1Hz, 0.1Hz (direct), 100Hz, 10Hz, 1Hz (pre-scaler) |
| Accuracy | ± 1 count \pm time base accuracy |

Period Measurements

| | |
|------------------------|--|
| Range | 100ms – 1 μ s |
| Multiplication Factors | $\times 10$, $\times 100$, $\times 1000$ |
| Resolution | 10 μ s, 1 μ s, 0.1 μ s |
| Accuracy | ± 1 count \pm time base accuracy \pm trigger error |

Input Section

| | |
|-----------------------|--|
| Input sensitivity | |
| (1M Ω) | 20mVrms (10Hz – 80MHz) 50mVrms (80MHz – 520MHz) |
| (50 Ω) | 20mVrms (100kHz – 80MHz) 50mVrms (80MHz – 520MHz) |
| Attenuator | 1, 1/10 |
| Coupling | AC |
| Input impedance | Switchable 1M Ω and 50 Ω . |
| Maximum input voltage | 10Hz – 400Hz : 100Vrms |
| (1M Ω) | 400Hz – 100kHz : 20Vrms 100kHz – 520MHz : 5Vrms |
| (50 Ω) | 100kHz – 520MHz : 5Vrms |

| | | | |
|------------------------|-----------------------------|--|----------------|
| Time base | | | |
| | LDC-824(S) | | |
| | Frequency | 10MHz (OVEN) | |
| | Accuracy | $\pm 1 \times 10^{-6}$ (± 1 ppm) (32°F – 104°F) (0°C – 40°C) | |
| | | Regular | Option |
| | Clock out | 1Vp-p 10MHz | 1Vp-p 1MHz |
| | External clock | 1Vp-p – 10Vp-p | 1Vp-p – 10Vp-p |
| General Specifications | | | |
| | Display | 8 digits, 7 segment fluorescent display overflow indication, gate indication and zero blanking | |
| | Operating temperature range | 0°C – 40°C (32°F – 104°F) | |
| | Power source | 100V, 117V, 200V, 234V \pm 10% 50Hz – 60Hz (Voltage-change is accomplished by change on tap of trans- former) | |
| | Power consumption | Approx. 12VA, Approx. 18VA (with optional) | |
| | Dimensions | 74(H) \times 200(W) \times 250(D)mm Approx. 3"(H) \times 8"(W) \times 10"(D) excluding knobs and legs | |
| | Weight | Approx. 2.6 kg Approx. 2.8 kg (with optional) Approx. 5¾ lbs. Approx. 6¼ lbs. (with optional) | |
| | Accessories | Clip cable with BNC connector | |

3. PANEL FUNCTIONS

3.1 Front Panel

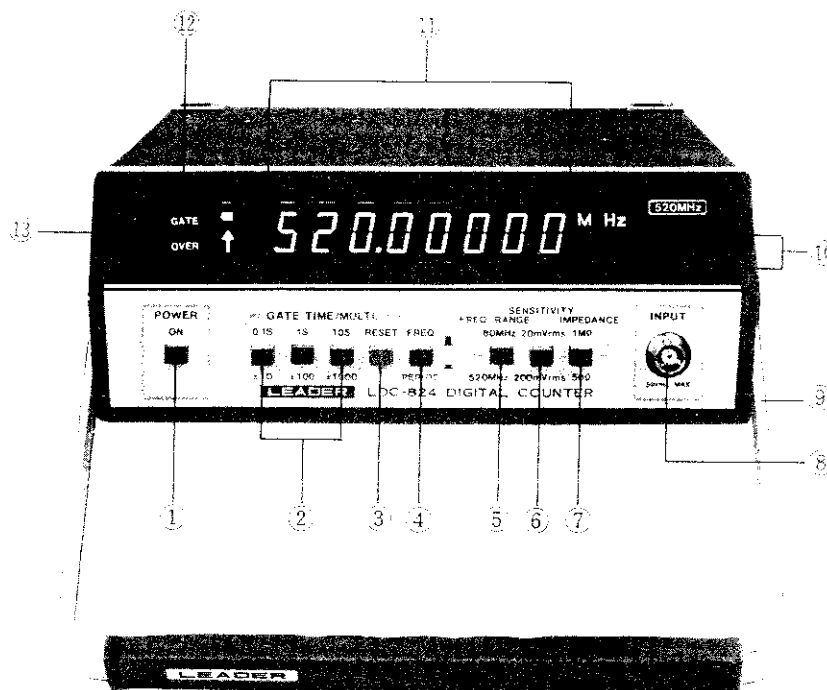

Fig. 3-1

Fig. 3-1 shows the front panel of LDC-824(S).

- ① Power switch.
To turn on, depress push-button, to turn off, again depress push button.
- ② GATE TIME: MULTIPLIER SELECTOR:
For frequency measurement, this switch is used to change GATE TIME: when in the period-measurement mode, it is used to change the multiplier factors. Each range is as follows:
GATE TIME: 0.1, 1 and 10 sec.
MULTI.: $\times 10$, $\times 100$ and $\times 1000$
- ③ RESET Switch:
By pressing this switch, the counter stops its operation. When released, the display is cleared to zero. After a delay of approximately 0.1s, if there is an input signal, the counter starts counting.
- ④ Function Selector:
A push button switch for changing the measurement mode is used for selecting the measurement functions of PERIOD and FREQ.
- ⑤ FREQ. RANGE Selector:
Selector for DIRECT MEASUREMENT (10Hz – 80MHz) and PRE-SCALER (50MHz – 520MHz).

- ⑥ SENSITIVITY Selector:
Push button switch for 20mV, 200mV, respectively.
- ⑦ IMPEDANCE Selector:
Selector for input impedance of 1MΩ and 50Ω.
- ⑧ INPUT Connector:
Put a signal in to measure.
- ⑨ Handle/Stand combination:
The lock of the handle can be released by pressing the mounted part of the handle on both sides with both hands. The handle can then be freely rotated. When the handle is released, it is locked.
- ⑩ Unit Indicator:
For frequency measurement, the indicator shows "MHz" at 520MHz Freq. Range, and "kHz" at 80MHz Freq. Range. "ms" is displayed in the case of period measurements.
- ⑪ Display:
It is a 8-digit, 7-segment, fluorescent display. In accordance with the measuring range, the decimal point is displayed automatically, and the leading zeros are blanked.
- ⑫ GATE indicator:
Displays the opened or closed state of the GATE. When GATE is open, indicator is lit.
- ⑬ OVERRANGE indicator:
Lights when the frequency is over the counting capacity of 8 digits. In the case of overrange, push the GATE TIME/MULTI selector to smaller values until the overrange indicator light goes off.

3.2 Rear Panel:

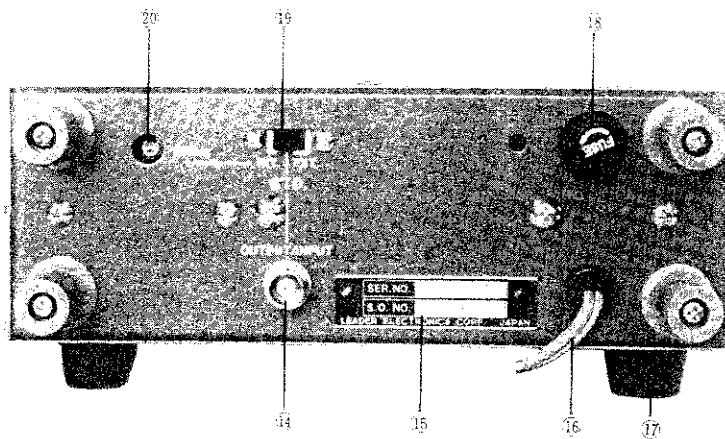

Fig. 3-2

- ⑭ OUTPUT/INPUT Terminal:
Output and input terminal for a clock signal. When the selector-switch ⑲ for internal and external (INT/EXT) is on INT, the internal clock is available to the terminal. Feed a clock to the terminal externally, when the selector switch ⑲ is on EXT.
- ⑮ Serial number label
- ⑯ Power cord
- ⑰ Rubber feet
- ⑱ Fuse holder (contains 0.3A fuse)
- ⑲ INT/EXT Switch:
Selector switch of an internal clock and an external clock.
- ⑳ With a screw driver, trimmer control adjustments of the reference frequency oscillator can be made. For procedure, refer to section 6 – Maintenance.

4. Operating Instruction

4.1 Precautions in use

- (1) In connecting the instrument to the device (to be tested), particularly in an internal connection, remove all AC power to the device, and remove the cord. After discharging all charged capacitors, connect the cable for measurement, thus, the danger of an electrical shock can be minimized. Take the same care in disconnecting the input cable.
- (2) Use AC-power source of LDC-824(S) at 50 – 60Hz, within 10% of rating voltage.
Caution: Excessively large or small AC voltages may induce erroneous operation.
- (3) In replacing the fuse, use the designated 0.3A fuse.
- (4) Avoid all the severe mechanical shocks to crystal oscillator or fluorescent indicators.
- (5) Reference clock: Wait about 20 minutes for correct measurement until the crystal oscillator gets stable in aging.

4.2 Fundamental Operation

- (1) Disconnect the input cable of the LDC-824(S).
- (2) Connect the AC power cord to the proper AC power source.
- (3) Set POWER switch to the ON position.
- (4) Set the function switch to FREQ.
- (5) Set the SENSITIVITY selector to 20mVrms.
- (6) Put the GATE TIME Selector at 0.1S.
When FREQ. RANGE Switch is 80MHz and 520MHz, Display reads 0.00 kHz and 0.0000 MHz respectively. The GATE indication is lighted for 0.1s while the gate is open, and disappears for 0.1s while the gate is closed.
- (7) Set GATE TIME Selector at 1S.
Display shows 0.000 kHz at 80 MHz and 0.00000 MHz at 520MHz. GATE indicator repeats to 1s light on/0.1s light off alternately.
- (8) Press the 10S GATE Selector
Display shows 0.0000 kHz at 80 MHz and 0.000000 MHz at 520MHz. GATE indicator repeats to 10s light on/0.1s light off alternately.

- (9) Set the FUNCTION switch to PERIOD.
- (10) Use the "MULTI" scales, and confirm the display as shown in Table 4-2-1. In the case that the displayed figure shows other than 0 (zero), or when GATE indicator is lighted, push the reset switch, then, GATE indicator disappears (gate is closed), and the display shows as in Table 4-2-1.

| MULTI | Display |
|-------|-----------|
| X10 | 0.00 ms |
| X100 | 0.000 ms |
| X1000 | 0.0000 ms |

Table 4-2-1

- (11) In the above 6-10 OVER-flow indicator always shows light off.

4.3 Input Connections

Connect BNC Connector of the accessory cable to the input terminal. Connect the ground - negative side of the clip to the common of the device under test. Connect the positive hot side to the test point. The input is AC only (DC blocked by 0.1 μ F capacitor). The maximum allowable voltage of the AC component of the input signal depends on frequency. The values are as follow:

| | | |
|-----------------------------|-----------------|--------------------|
| Input Impedance 1M Ω | 10Hz - 400Hz | 100Vrms or 280Vp-p |
| | 400Hz - 100kHz | 20Vrms or 56Vp-p |
| 50 Ω | 100kHz - 520MHz | 5Vrms or 14Vp-p |
| | 100kHz - 520MHz | 5Vrms or 14Vp-p |

The maximum voltage of the DC component of the input signal is ± 100 V DC. When the input signal is not a continuous sine-wave or is modulated, the following values are the maximum allowable AC input voltages permitted in accordance with the frequency chart below.

| | | |
|-----------------------------|-----------------|---------|
| Input Impedance 1M Ω | 10Hz - 400Hz | 250Vp-p |
| | 400Hz - 100kHz | 56Vp-p |
| 50 Ω | 100kHz - 520MHz | 14Vp-p |
| | 100kHz - 520MHz | 14Vp-p |

CAUTION NOTE: Caution should be taken not to get an electric shock when connecting or removing the input cable. High voltage circuits and horizontal output pulses of flyback transformers in TV-sets generate excessive voltages. The LDC-824(S) could be damaged by exceeding input limitations. Therefore, never make a direct connection to these circuits.

The input impedance of this instrument is approx. 1M Ω and shunted by approximately 30pF. The input cable has a distributed capacity of approx. 70pF. As the capacitance becomes 100pF in total, it is not recommended for such a circuit or a device under test as influenced by this capacitance to be measured.

Note: Do not connect the input of LDC-824(S) to a high impedance point of the device under test. The parallel effects of this 1M Ω /100pF combination affect the operation of the circuit being tested.

4.4 Setting of input sensitivity

(1) Input sensitivity and noise

The input sensitivity of LDC-824(S) can be selected from 0.02Vrms, or 0.2Vrms, in order to measure input signals of wide voltage ranges. When a large signal is applied to the input at the higher input sensitivity, the noise included in the input signal may induce miscounting. In this case, reduce the input sensitivity to the appropriate input range as listed in Table 4-4-1. This minimizes errors.

| Input sensitivity | Range of input voltage |
|-------------------|------------------------|
| 0.02Vrms | 0.02 – 0.2Vrms |
| 0.2Vrms | 0.2 – 2Vrms |

Table 4-4-1

(2) Automatic Trigger Level Function

The trigger level of LDC-824(S) is designed to function automatically in 80MHz frequency range.

Trigger level is set automatically to a level (Fig. 4-4-2) of input voltage that is divided equally into three parts. The functional range of automatic trigger level shall be, for instance, between 20mV and 200mV input voltage when preset sensitivity is 20mV. When it is preset at 200mV, the input voltage range for automatic trigger level is between 200mV and 2V. In the case the above-mentioned input voltage range is exceeded, the trigger level is fixed at 200mV position when preset at 20mV sensitivity and is fixed at 2V position when preset at 200mV sensitivity.

In accordance with all these, correct signal counting can be conducted (Fig. 4-4-2) without miscounting when noise voltage is 50% or less of the signal voltage and it is within the range of automatic trigger level.

In addition, measurement of pulse signals with large duty ratio can be conducted with ease, as the trigger level is set automatically at the optimum level, even if it has been necessary to adjust the trigger level for the pulse signal measurement.

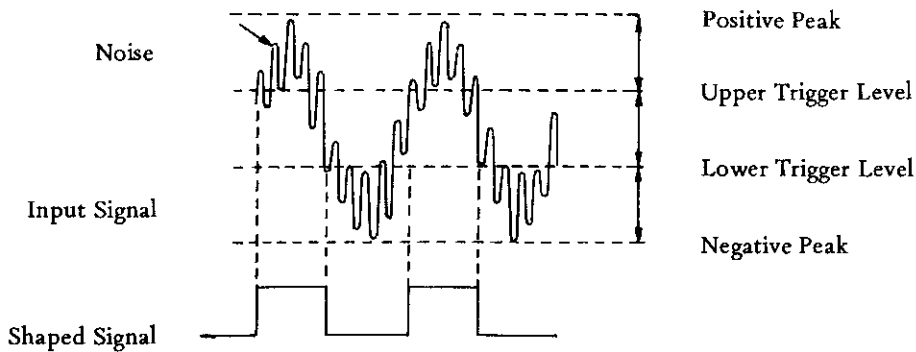

Fig. 4-4-2

(3) Measurements of Modulated Signals

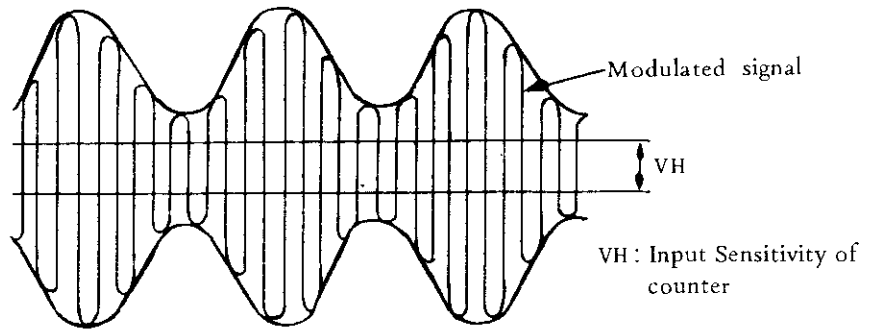

Fig. 4.4-3

As seen in the above Fig. 4.4-3, in order to measure the frequency of modulated carrier-wave, if the voltage of highest modulated part is greater than the input sensitivity V_H (0.02Vrms), it is then possible to count the carrier-wave.

4.5 Frequency measurement

Set the function switch to **FREQ.** and apply signal to the input connector. The measuring range is 10Hz – 520MHz. By setting the **GATE** time to the values shown in Table 4-5-1 and Table 4-5-2, measurement can be done at the maximum resolution without overrange.

DIRECT MEASUREMENT (up to 80 MHz)

| Gate Time | Measuring frequency | Display |
|-----------|---------------------|--------------------------|
| 10 S | 10Hz – 9999.9999kHz | 0.0100kHz – 9999.9999kHz |
| 1 S | 10Hz – 80000.000kHz | 0.010kHz – 80000.000kHz |
| 0.1 S | 10Hz – 80000.00kHz | 0.01kHz – 80000.00kHz |

Table 4-5-1

PRE-SCALER (up to 520 MHz)

| Gate Time | Measuring frequency | Display |
|-----------|----------------------|----------------------------|
| 10 S | 10Hz – 99.999999MHz | 0.000010MHz – 99.999999MHz |
| 1 S | 10Hz – 520.00000MHz | 0.00001MHz – 520.00000MHz |
| 0.1 S | 100Hz – 520.00000MHz | 0.0001MHz – 520.0000MHz |

Table 4-5-2

In measuring the frequency of 10Hz – 1kHz at a high resolution, period-measurement is more suitable.

4.6 Period measurement

- (1) Set the function switch to **PERIOD**, and apply the signal to the input connector. The measuring range is 100ms – 0.001ms (1 μ s). Period measurement is suitable for accurate measurement in the frequency range of 10Hz – 1kHz.

By setting the **MULTI.** and **PERIOD** as listed in Tables 4-6-1 and 4-6-2, more accurate

measurements can be accomplished within a short time and longer numerical display measurement results in a more accurate measurement.

When the measuring time is within 1s – 0.1s,

| Frequency | Period | MULTI | Display |
|--------------|--------------|-------|---------------------|
| 10Hz–100Hz | 100ms – 10ms | ×10 | 100.00ms – 10.00ms |
| 100Hz – 1kHz | 10ms – 1ms | ×100 | 10.000ms – 1.000ms |
| 1kHz – 10kHz | 1ms – 0.1ms | ×1000 | 1.0000ms – 0.1000ms |

Table 4-6-1

When the measuring time is within 10s – 1s,

| Frequency | Period | MULTI | Display |
|--------------|--------------|-------|----------------------|
| 10Hz – 100Hz | 100ms – 10ms | ×100 | 100.000ms – 10.000ms |
| 100Hz – 1kHz | 10ms – 1ms | ×1000 | 10.0000ms – 1.0000ms |

Table 4-6-2

(2) Measuring accuracy

The accuracy of period measurement can be expressed as follows:

$$\text{Accuracy} = \pm 1 \text{ count} \pm \text{trigger error} \pm \text{time base accuracy} \dots \text{Equation 4-6-1.}$$

In the above equation, the most important factor is the trigger-error. Trigger-error occurs with the overlapped signal noise and noise in the counter. During the measurement, when the display fluctuating range is within ± 1 , the error can be regarded as ± 1 count. If it is over ± 1 count, it may be trigger-error or alteration of the input signal. As a checking method, when the input sensitivity of counter or input voltage is set to higher values, if the variable range becomes less, it can be judged as trigger error.

In order to reduce the effect of input signal noise the trigger-error can be reduced by raising the input voltage or by rectifying the input-wave into rectangular wave-form applying to LDC-824(S).

5. BLOCK DIAGRAM

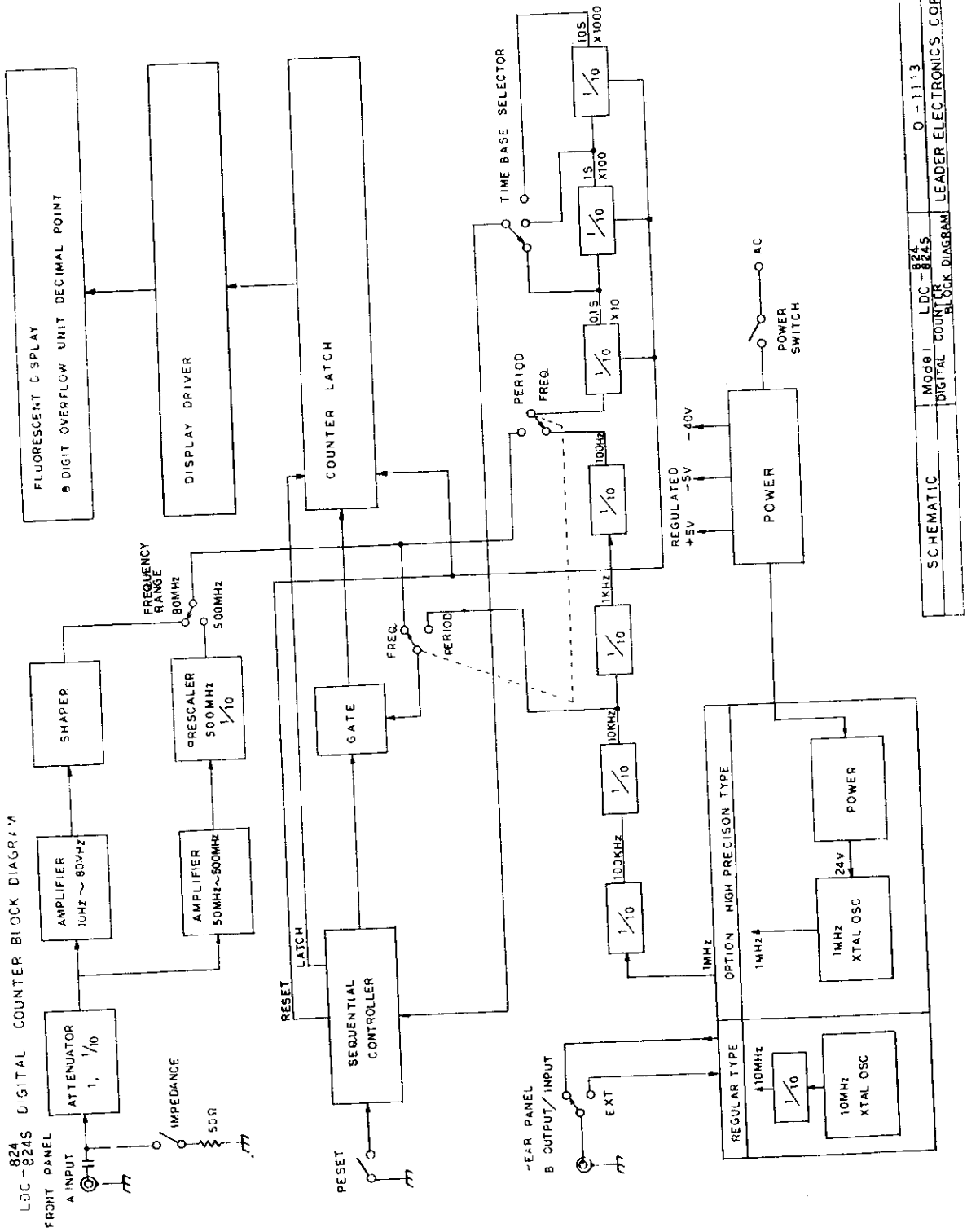

| | | | |
|--|----------------|--------|-----|
| SCHEMATIC | Model LDC-824S | 0-1113 | 1/4 |
| DIGITAL COUNTER BLOCK DIAGRAM LEADER ELECTRONICS CORP. | | | |

6. MAINTENANCE

- (1) To calibrate or adjust the reference oscillator.

Set GATE TIME selector to 10s and FREQ. RANGE selector to 80 MHz.

A standard 10MHz signal generator with an accuracy greater than $\pm 1 \times 10^{-8}$ is required for calibration. Apply the output of standard signal generator to the input terminal of LDC-824 (S) to measure the frequency. A normally operating counter displays 10MHz. If you read other than 10MHz, adjust the trimmer capacitor with the screw driver through the hole for adjustment provided at the rear panel of the LDC-824(S), in order to make exact accurate display.

- (2) The LDC-824(S) has been designed for easy maintenance and high reliability by employing LSI/MSI IC's for the digital and power-source sections of this instrument.
- (3) If the instrument fails to perform in the manner specified herein, write or call your nearest Leader office for factory-trained service. For safety reasons, and to prevent damage to the instrument, DO NOT REMOVE the unit from the case.

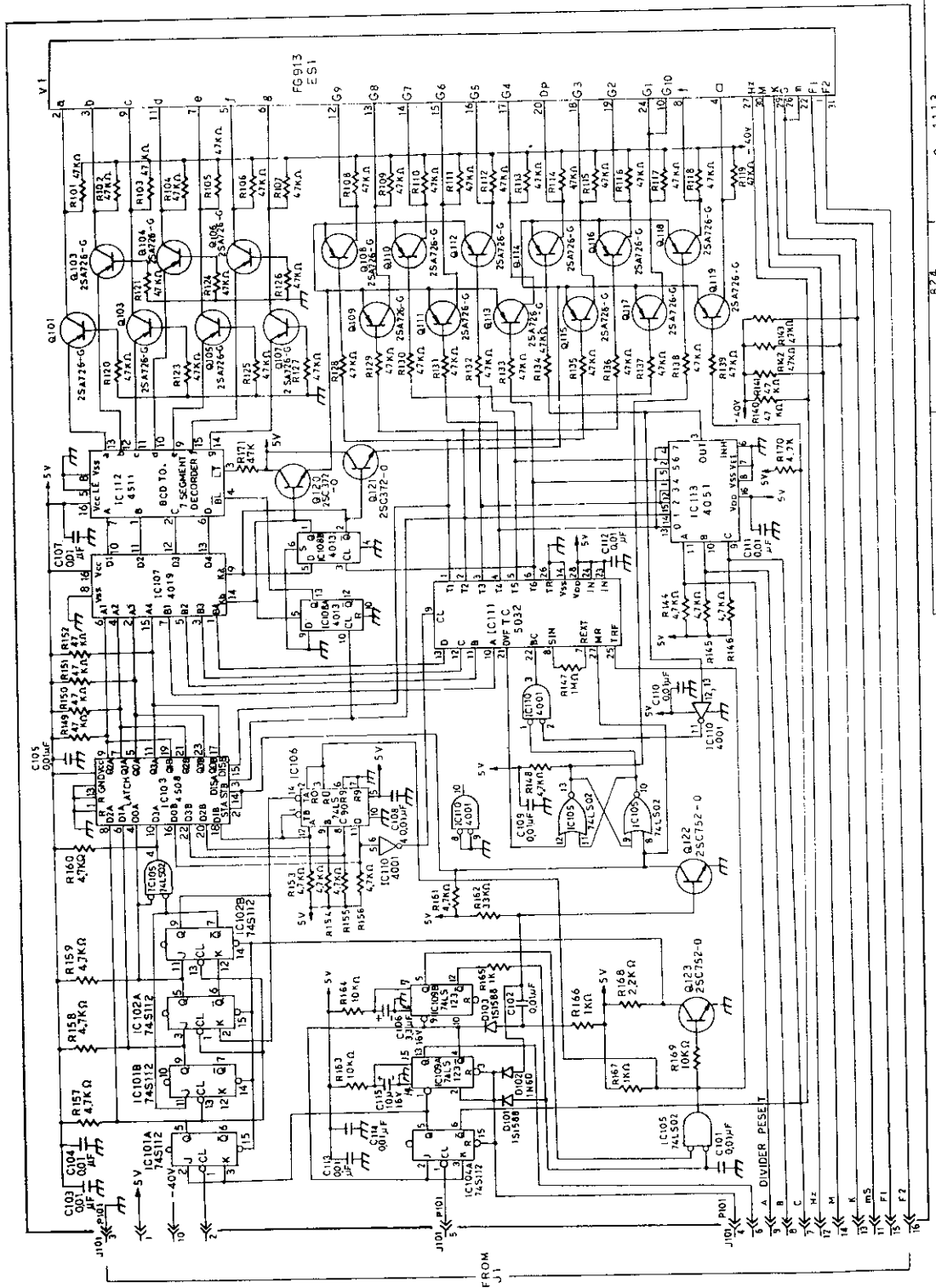

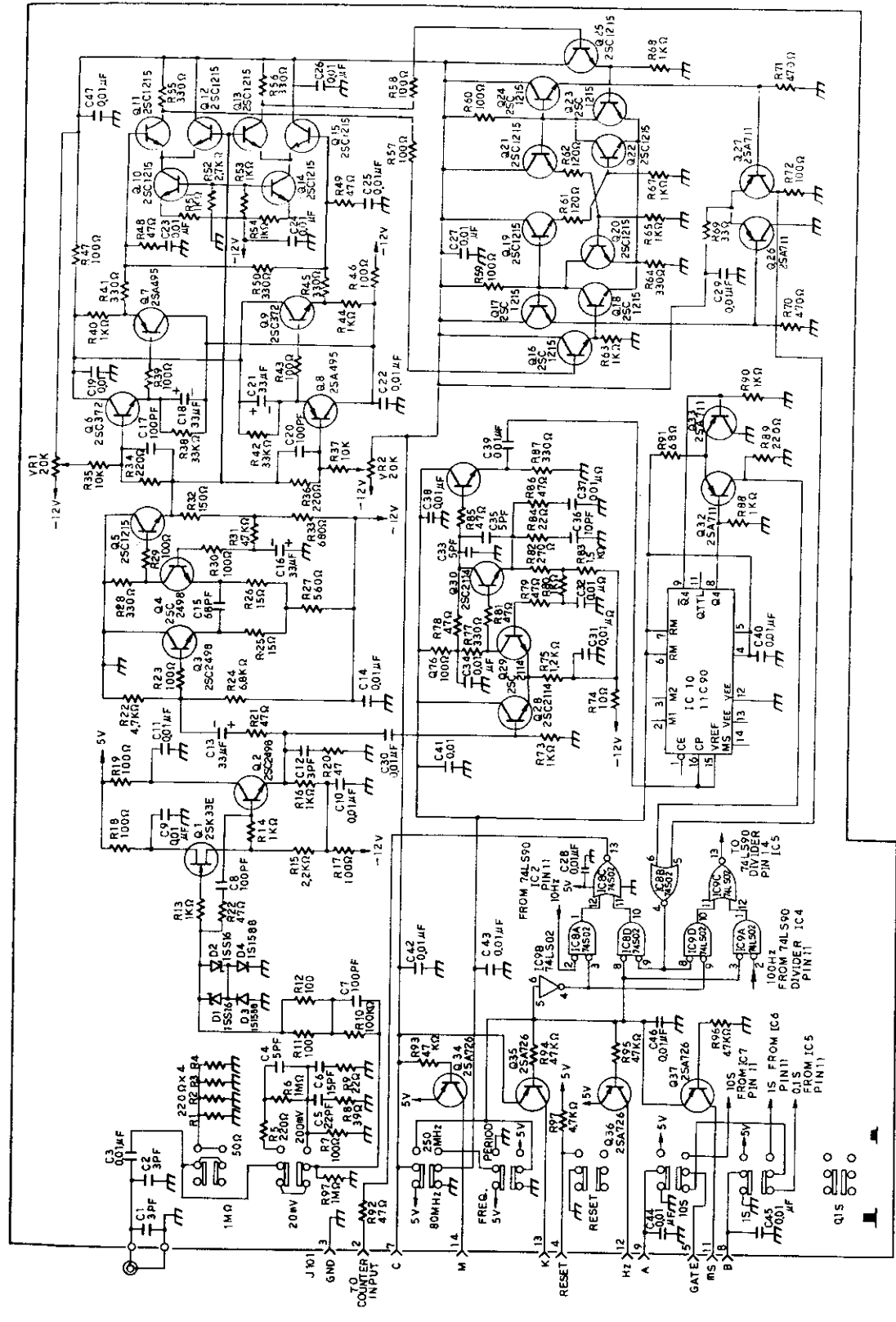

SCHEMATIC MODEL LDC-8645
INPUT AMP. & PRESCALER LEADER ELECTRONICS CORP.

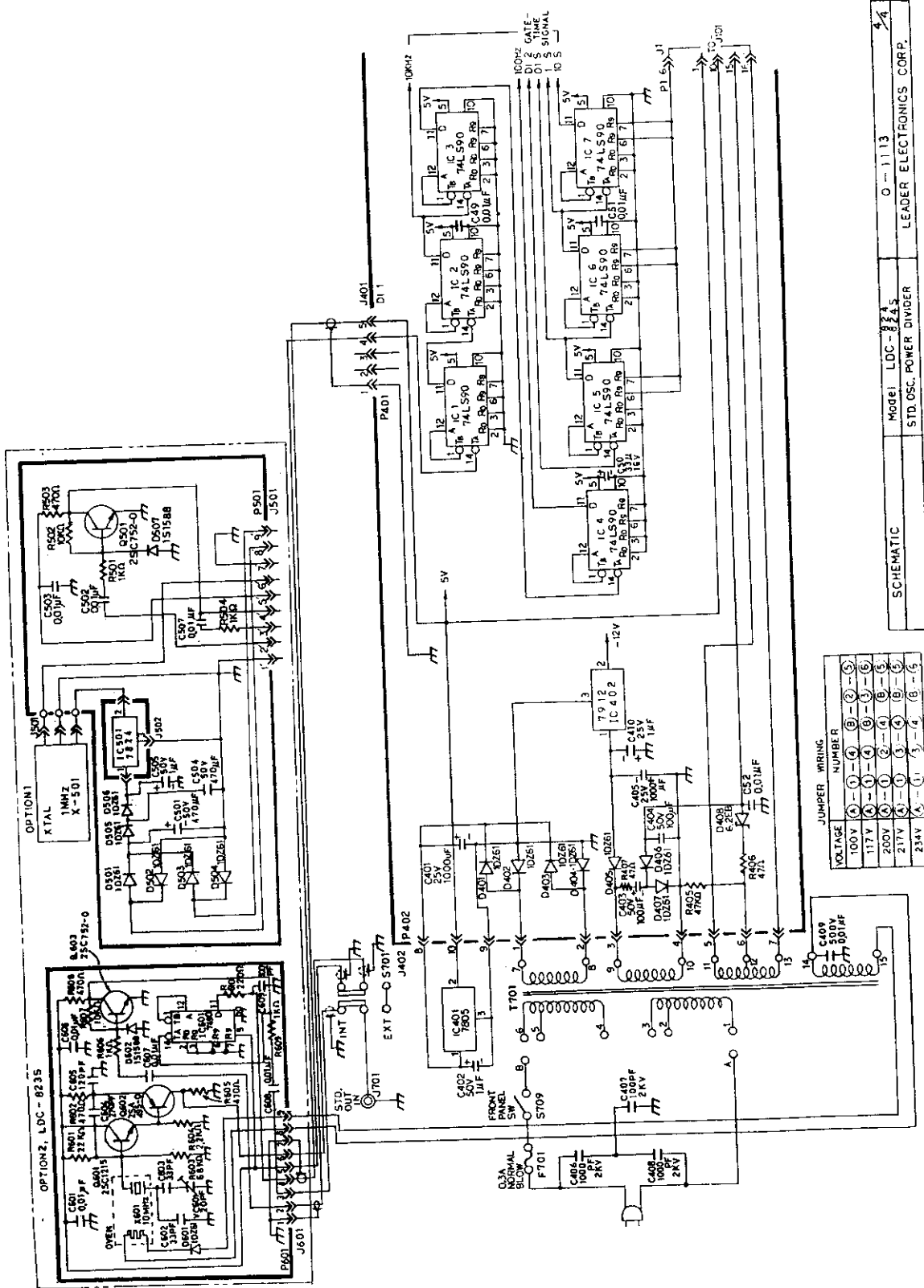

| JUMPER NUMBER | |
|---------------|-------------------------|
| VOLTAGE | NUMBER |
| 100V | (A)-(1)-(4)-(B)-(2)-(5) |
| 117V | (A)-(1)-(4)-(B)-(1)-(6) |
| 200V | (A)-(1)-(2)-(4)-(B)-(6) |
| 217V | (A)-(1)-(3)-(4)-(B)-(5) |
| 234V | (A)-(1)-(3)-(4)-(B)-(6) |

SCHEMATIC MODEL LDC-8245 0-1113 LEADER ELECTRONICS CORP.