

# TATUNG

# 170 CHASSIS

---

MODEL

---

SERVICE MANUAL

---

## SECTION 1 - INTRODUCTION

### 1.1 General Description.

The 170 Series colour television chassis, all used to drive 90° picture tubes, consists of a number of types:

Type 170 - for 14" (36cm) and 16" (42cm) conventional tubes.  
Type 170Q - for 15" (39cm) FST tubes.  
Type 171 - for 20" (51cm) and 22" (56cm) conventional tubes.  
Type 171Q - for 19"/21" (50/55cm) FST tubes - standard neck.  
Type 172Q - for 19"/21" (50/55cm) FST tubes - mini neck  
Type 172QS - for 21" (55cm) playback stereo.

The 180 Series chassis is designed to drive 110° 25" (63cm) and 28" (70cm) FST type tubes.

Type 180S is for stereo models.

All incorporate a micro-computer controlled 30-programme frequency synthesis tuning system (System 70.). Full remote control, using the battery powered RC70 hand unit, operates the programme change, picture settings, volume, muting and standby functions. Local (front panel) controls provide back-up for programme change and volume functions in the event of remote control hand unit failure, as well as Search and Memory controls for setting-up purposes (see para 1.2).

Teletext, if fitted, can be accessed and operated only through the remote control hand unit which incorporates a full range of operating buttons.

Some models are fitted with a Euroconnector (SCART socket) and stereo amplifiers.

### 1.2 Setting-up the Receiver.

The setting-up procedures to allocate TV channels and ancillary equipment to the receivers programme numbers involve the use of the remote control hand unit and/or the local controls on the receivers front panel. The method adopted depends upon whether or not the TV channels official numbers are known.

#### a) If the official channel numbers are known.

Press the remote control PROG/PAGE+ or PROG/PAGE- button (or the local PROG+ or PROG- button) to select programme 1 as indicated on the fascia display. Press remote button CS and then key in the channel number for BBC1. The keyed-in number appears on the digital display, whilst the receiver automatically tunes in the channel. The display reverts to showing the programme number after a short while. Once the selected channel appears on the screen, press local button MEM (memorise) to permanently allocate the channel to the programme.

Press remote button PROG/PAGE+ (or local PROG+ button) to select programme 2. Press remote button CS and key in the channel number for BBC2. When the selected channel appears on the screen, press local button MEM.

### 1.3 General Specification (170 Series)

		MODELS System I	MODELS System B/G
Mains Supply Voltage		220/240 V 50Hz	220/240 V 50Hz
Power Consumption (Normal Picture)	14"/15" 19"/22"	50/55 Watts 70/75 Watts	50/55 Watts 70/75 Watts
E.H.T.	14"/15" 19"/22"	23kV 25kV	23kV 25kV
Deflection angle		90°	90°
Frequency synthesis tuning		Channels 21-69 (470-860MHz)	E2-S1, E5-S20, E21-69 (47-300MHz, 470-860MHz)
Vision IF frequency		39.5MHz	38.9MHz
Sound IF frequency		33.5MHz	33.4MHz
Sound intercarrier frequency		6MHz	5.5MHz
Audio output power (approx) @ 1kHz RMS	14"/15" 19"/22" 21" mono 21" stereo	1.5 watts 3 watts 3 watts 4 watts x 2	1.5 watts 3 watts 3 watts 4 watts x 2
Colour Sensitivity		30uV	30uV
Possible Model Variants		Teletext (CCT) AV/RGB interface (Euroconnector) Stereo amplifiers	Teletext (CCT) AV/RGB interface (Euroconnector) Stereo amplifiers German broadcast stereo SECAM (System B/G)
Remote Control Hand Unit Batteries (3V)		RC70 full feature 2 x AAA	RC70 full feature 2 x AAA
Safety Standard conforms to:		BS415, class 2 - isolated chassis	IEC65, class 2 - isolated chassis
Radiation/immunity conforms to:			FTZ (W. Germany).

#### 1.4 General Specification (180 Series)

	MODELS System I	MODELS System B/G
Mains Supply Voltage	220/240V, 50Hz	220/240V, 50Hz.
Power Consumption (Normal Picture) (* Refers to high power stereo, max. consumption)	80-110* Watts	80-110* Watts.
E.H.T.	25kV	25kV
Deflection angle	110°	110°
Frequency Synthesis Tuning	Channels 21-69 (470-860MHz)	Channels E2-S1 E5-S20, E21-E69 (47-300MHz, 470-860MHz).
Vision IF Frequency	39.5MHz	38.9MHz
Sound IF Frequency	33.5MHz	33.4MHz
Sound Inter-carrier Frequency	6MHz	5.5MHz
Audio Output Power (approx) @ 1KHz RMS.		
- Mono	3 Watts	3 Watts
- Stereo	4 Watts (5)	4 Watts (5)
- High Power Stereo	2 x 6 Watts (7.5)	6 Watts (7.5)
(Ext Speakers)	2 x 12 Watts (15)	12 Watts (15)
Colour Sensitivity	30uV	30uV
Possible Model Variants	Teletext (CCT) AV/RGB interface (Euroconnector) Stereo Amps.	Teletext (CCT) AV/RGB interface (Euroconnector) Stereo Amps. German b'cast stereo SECAM (system B/G).
Remote Control - Hand Unit - Batteries -	RC70 full feature 2 x AAA	RD70 full feature 2 x AAA
Safety Standard Conforms to:	BS415, Class 2 Isolated Chassis	IEC 65 Class 2 Isolated Chassis.
Radiation/immunity conforms to:		FTZ (W. Germany).

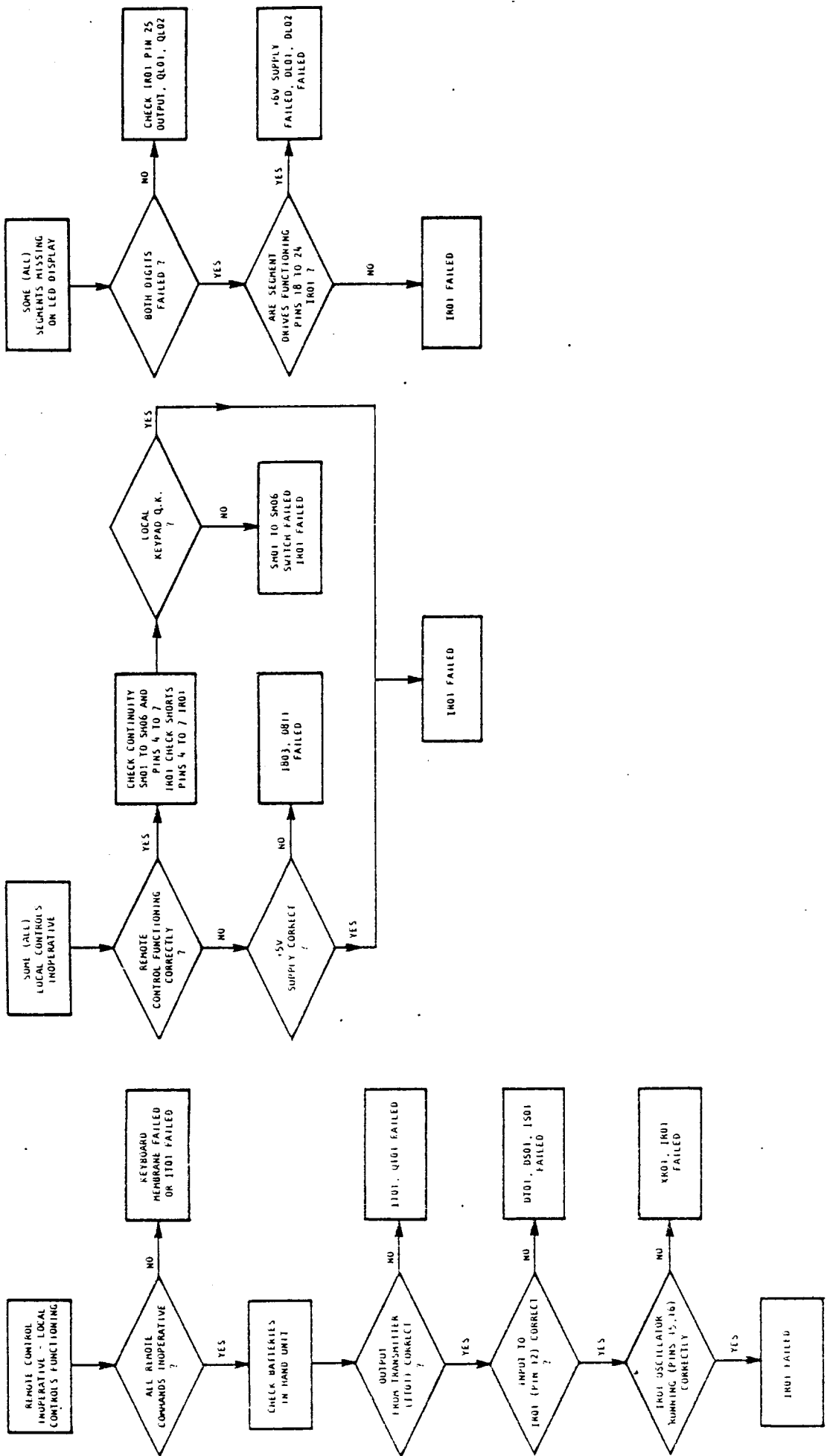

Fig 3.7 Fault Finding Chart-Controls and Indications

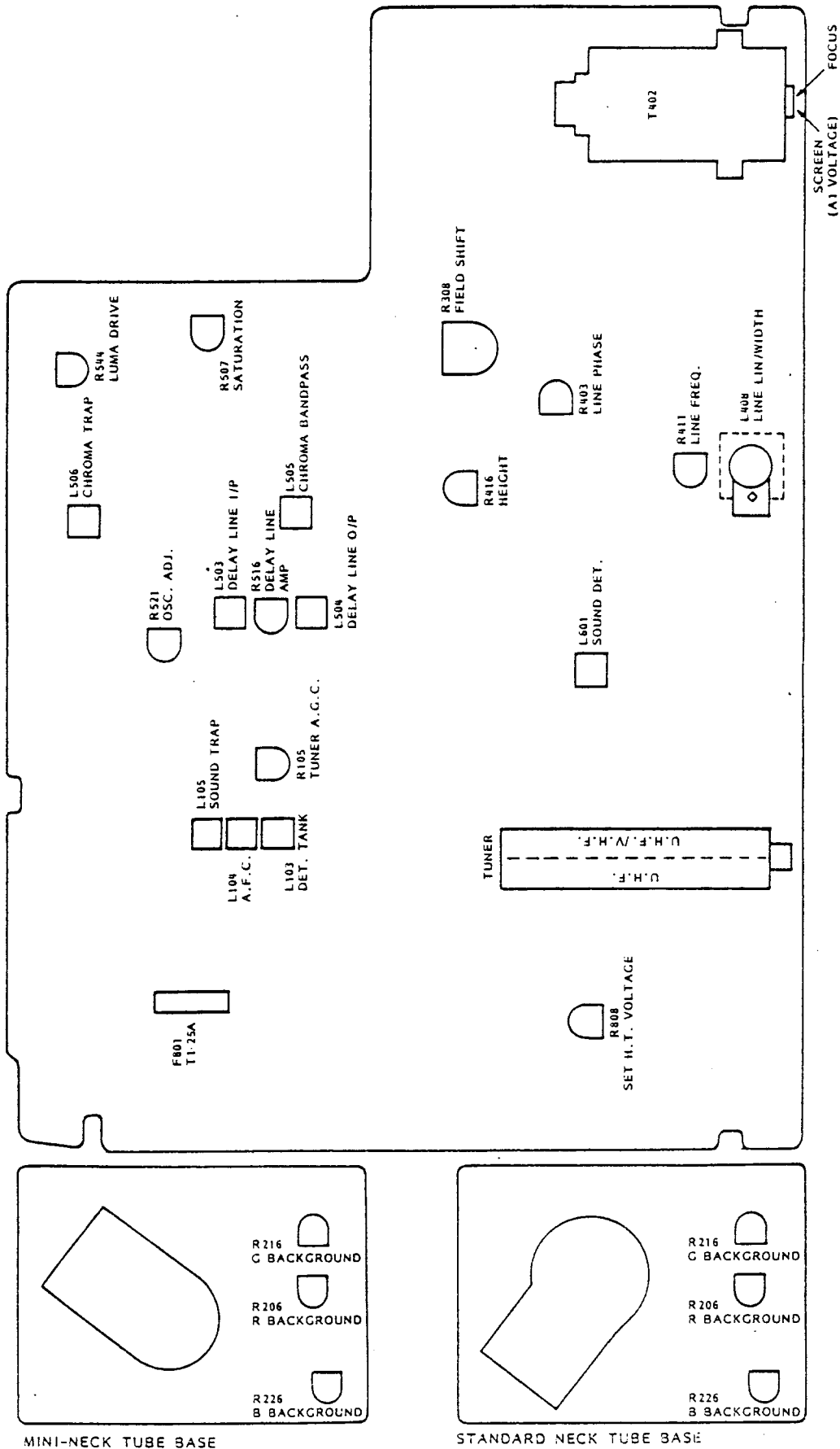

Fig 4.1 a) 170 Series Location of Adjustments  
 - Main p.c.b. and Tube Base p.c.b.'s.

### 4.3 Vision and Sound IF Alignment Procedures

#### 4.3.1 AFC Coil Alignment

- (a) Tune the receiver to a channel away from strong local transmissions.
- (b) Remove any connection to the aerial input socket.
- (c) Connect the unmodulated signal source (4.1.5), via a 68 ohm terminating resistor, to the junction of the tuner output and the input to the SAW filter. Connect the screen of the generator output cable to the 0V connection of the tuner.
- (d) Set the generator accurately ( $\pm 10$  kHz) to the I.F. frequency (38.9 MHz for System B & G, 39.5 MHz for System I).
- (e) Set the generator output level to 100mV (pd).
- (f) Monitor the a.f.c. voltage across C119, using the multimeter set to a suitable d.c. range.
- (g) Adjust the a.f.c. coil (L104) to give 6V  $\pm 0.5$ V. At the correct tuning point a small adjustment will have a large effect on voltage which will swing rapidly from almost 0V to 12V.

Note; There may be other incorrect tuning points which will give 6V. These incorrect points can be identified because they will give a relatively slow rate of voltage change and will not give the full voltage swing.

- (h) Disconnect the signal generator and the multimeter.

#### 4.3.2 Vision IF Detector Tank Coil Alignment

- (a) Connect the output of the TV Generator (4.1.2) to the aerial input of chassis.
- (b) Set the generator to any convenient TV channel.
- (c) Set the generator output to 3mV.
- (d) Tune the TV to the generator output channel.
- (e) Monitor the video output on R116 with the oscilloscope.
- (f) Adjust vision detector coil L103 for correct video waveform, and minimum amplitude, and a square corner to the start of the white bar of colour bars. Note: the adjustment for square corner is the most important criteria of correct alignment, but this can only be carried out properly with a vestigial sideband signal generator (as specified in paragraph 4.1.2. (e)).

#### 4.3.5 Sound Detector Coil Alignment.

- (a) Disable the video IF by short-circuiting C106 (IF a.g.c.)
- (b) Connect the RF signal generator (4.1.4) to the video output of I101 (IF IC), at the junction of L101 and C115/C105, via a d.c. blocking capacitor of value 10nF.
- (c) Set the signal generator to the appropriate sound intercarrier frequency i.e. 5.5. MHz for system B & G, 6.0MHz for system I, at an output of 100mV r.m.s. modulated with 1kHz sinewave at 50kHz deviation.
- (d) Monitor the audio output on C603 or M601, pin 2 with a 'scope'.
- (e) Disconnect the loudspeaker (or any other loads) from M601.
- (f) Adjust the customer volume control (with local or remote control) until an output is obtained.
- (g) Adjust the sound detector coil (L601) until a low distortion output is obtained. Re-adjust the volume control as necessary during this process to give a large output without clipping.

Note: there may be three tuning points. The correct one is the middle one.

- (h) Adjust the volume control to give approx. 10V p-p, as measured on the 'scope.
- (j) Switch in the 1kHz audio rejection filter in series with the 'scope input in order to eliminate most of the fundamental audio signal.
- (k) Slightly re-adjust the sound detector coil (L601) to achieve minimum residual distortion and noise as seen on the 'scope.
- (l) Apply a load across M601 pins 1 & 2.  
15 ohms on a 170 chassis  
8 ohms on a 171/172 and 180 chassis.
- (m) Distortion should have increased only slightly (0.6% is typical).
- (n) Switch out the 1kHz audio rejection filter.
- (p) Increase the volume level and check that 1.5W on the 170 chassis, or 3W on the 171/172 or 180 chassis can be obtained with less than 10% distortion.
- (r) Disconnect all test equipment from the chassis.



#### 4.5 Video Output Adjustments (170 Series).

##### 4.5.1 Black Levels.

- (a) Input via the aerial socket an RF signal modulated with standard colour bars.
- (b) Reduce the A1 control to zero.
- (c) Adjust line user brightness control to its mid-position and check that the R,G,B outputs of I501 (pins 13,15, and 17) are at approx. 4.6V black level.
- (d) Adjust presets R206, R216 and R226 so that the black level measured at each CRT cathode (R905, R906 and R907 respectively) is 150V.

##### 4.5.2 Luma Drive.

- (a) Maintaining the same input signal and ensuring the A1 is at a minimum, set the brightness and contrast to mid-position (NORMALISE).
- (b) With an oscilloscope monitor the signal at the junction of R906 and Q202 collector.
- (c) Adjust R544 for a black-to-white drive voltage of 50V (170 Chassis) or 65V (171 chassis).

##### 4.5.3 Picture Tube Adjustments (R,G,B backgrounds).

- (a) Input a grey-scale signal from a suitable RF source.
- (b) NORMALISE the user controls and increase the A1 control for correct overall black level on display.
- (c) Grey-scale corrections may now be carried out with small adjustments to only two of the presets mentioned in para. 4.5.1 (d).

#### 4.6 Video Output Adjustments (180 Series).

The video amplifier circuit makes use of the automatic black level facility incorporated in a decoder I.C. (I051). During a 4-line period of field blanking three consecutive pulses are sent out, one to each amplifier input. An output transistor (Q202, Q205, Q208) monitors the current in each cathode. The three returning pulses are combined and then fed back to the decoder I.C. (I051, pin 18). The black level of each output is then compared with a reference level and the three outputs are adjusted by the I.C. This system dispenses with the need for background adjustments.

#### 4.7.4 Line Width/ E-W Correction (180 Series).

- (a) Adjust E-W modulation preset R316 for best vertical line on left-hand outside edge of the picture. If necessary, first reduce overall picture width with preset R313.
- (b) Adjust preset R313 to obtain correct picture width.

#### 4.7.5 Field Shift/Field Height.

- (a) Adjust R308 to give a vertically centred picture.
- (b) Adjust R416 to obtain the correct picture height.
- (c) If necessary re-adjust the two controls to optimise the picture.

#### 4.8 Picture Tube Focus Adjustment

- (a) Tune the receiver to a signal containing fine picture detail.
- (b) Adjust the Focus control for maximum picture clarity and definition.

#### 4.9 Teletext Decoder - Setting Up.

The adjustments on the teletext decoder are confined to setting text contrast, and setting the 6MHz VCO of the character display clock (PLL).

##### 4.9.1 Text Contrast.

- (a) Ensure greyscale tracking is correct.
- (b) NORMALise the brightness and contrast controls via the remote control hand unit.
- (c) Select a page of text and put the receiver into the MIX mode. Adjust RR120 so that the brightness balance between text and picture information is correct.

##### 4.9.2 6MHz VCO

- (a) Make the VCO 'free run' by disconnecting the video input to VIP2 or tuning to a blank channel. This causes the Signal Quality Detector in CCT to measure a 'bad' signal. This forces PL to be low, causing the VCO to free run.
- (b) Connect a frequency counter to the F6 signal (IR101, Pin 17).
- (c) Adjust CR116 until the F6 frequency is 6010 KHz +/- 5 KHz.

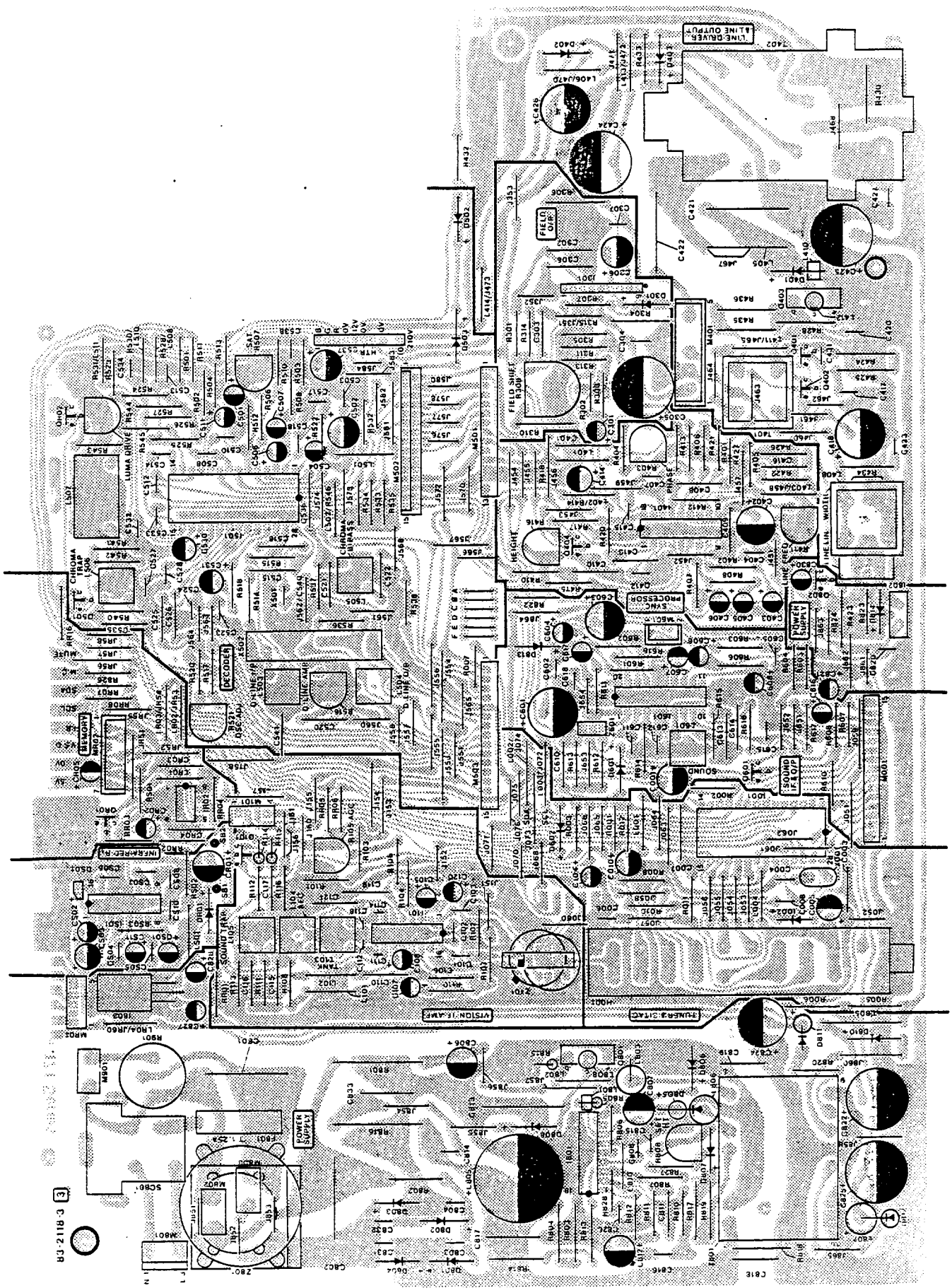

Fig 4.2 (a) 170 Series Main Chassis p.w.b. - component side

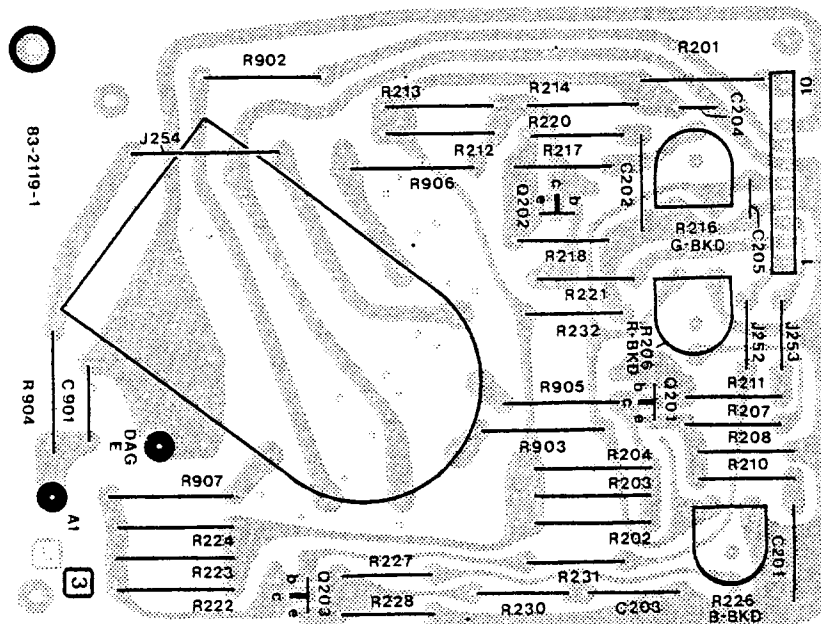

Fig 4.3 (a) 170 Series Tube Base p.w.b. (mini neck) - component side  
(170,170Q,172Q chassis)

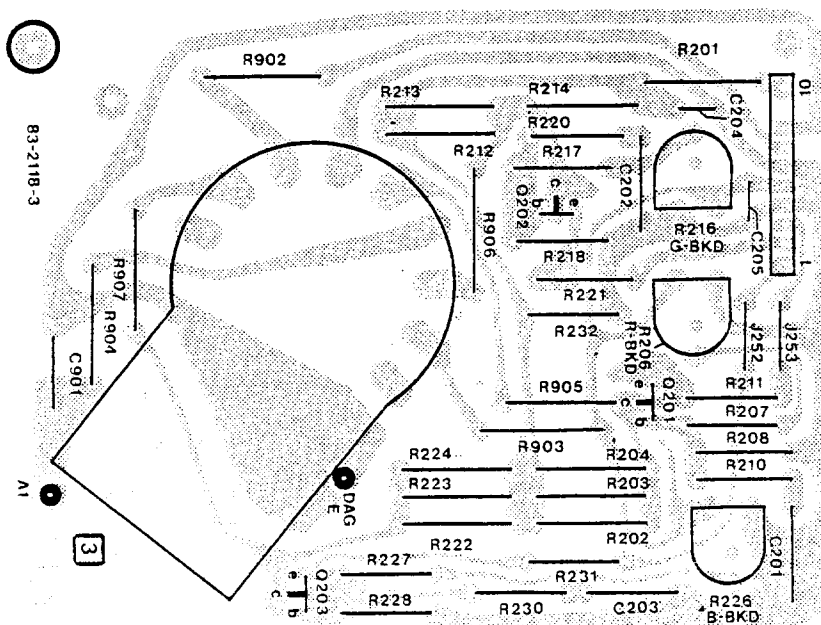

Fig 4.3 (b) 170 Series Tube Base p.w.b. (standard neck) - component side  
(171,171Q chassis)

## SECTION 5 - PARTS LIST

The following parts list details those components which should be replaced only with factory supplied parts. To obtain spares contact the Service Division at the address shown on the front cover of this publication, quoting the code number given.

Components marked  $\triangle$  in the Parts List and on the circuit diagram are safety approved types and should only be replaced with components supplied by our Service Division. All other components should be replaced with parts of the type and rating of those originally fitted. If in doubt contact the Service Division for advice.

In the following parts lists certain items are fitted to only System I or only German system receivers. These items are identified as follows:

\* System I only      + German System only.

In the capacitor listings the different types are identified as follows:

C - ceramic; CD - ceramic disc; CP - ceramic; E - Electrolytic  
MP - metallised polyester; P - polystyrene; PP - polypropylene;  
TC - tubular ceramic.

### 5.1 Main Chassis and Tube Base Board. (170 Series)

#### 5.1.1 Resistors

The majority of resistors are standard carbon film types, readily available from component stockists. Refer to the circuit diagram for values. Note that, unless marked otherwise on the circuit diagram, resistors are either  $\frac{1}{4}$  watt or  $\frac{1}{2}$  watt rated. Replacements should always be of a power rating equal to the originals. This is particularly important for those resistors which are stood off the p.c.b.

Cct Ref	Value	Tolerance	Rating	Type	Code No.
R105	10K	20%	----	Linear pot	12-2682-7
R201 $\triangle$	10R	5%	0.4W	Mullard SFR25 11-5200-9/P1	
R202,203,204	47K	2%	0.5W		11-5108-8
R206	2K2	20%	----	Preset linear pot	12-2467-0
R212,213,214	47K	2%	0.5W		11-5108-8
R216	2K2	20%	----	Preset linear pot	12-2467-0
R222,223,224	47K	2%	0.5W		11-5108-8
R226	2K2	20%	----	Preset linear pot	12-2467-0
R308	1K0	20%	----	Preset linear pot	12-3165-0
R403	47K	20%	----	Preset linear pot	12-2585-5
R411	4K7	20%	----	Preset linear pot	12-2354-2
R416	100K	20%	----	Preset linear pot	12-2455-7
R416 (170Q)	220K	20%	----	Preset linear pot	12-2859-5
R507	22K	20%	----	Preset linear pot	12-4574-0

C806,807,812	100u	20%	25V	E	14-6856-1
C813	1n5	5%	1.5KV	PP	14-6649-6
C814	47n	20%	400V	MP	14-4419-0
C817	100n	20%	400V	MP	14-5003-4
C818 $\Delta$	1n0	20%	400V a.c.	C	14-6949-5
C822	47n	20%	250V	E	14-6707-7
C824	1000u	20%	16V	E	14-3846-8
C825	2200u	20%	35V	E	14-4733-5
C831,832	1n	20%	2KV	C	14-6937-1
C901	10n	-20%/+80%	2KV	CD	14-3906-5
CR01	100u	20%	50V	E	14-6858-8
CR05	100u	20%	10V	E	14-6854-5
CS03	100u	20%	10V	E	14-6854-5
CT01 )	100p	2%	100V	CP	14-6884-7
CT02 ) (RC70)	120p	2%	100V	CP	14-6946-0
CT03 )	470u	-10%/+75%	6.3V	E	14-4891-9

### 5.1.3 Coils, Chokes, Ferrite Beads, Delay Lines.

<u>Cct Ref</u>	<u>Description</u>	<u>Code No.</u>
L001,L004	Choke 10uH	15-7528-7
L101	Choke 3u3H	15-7603-8
L102	Choke 10uH	15-7528-7
L103	Tank Coil	85-9802-9
L104	AFC Coil	85-9811-8
L105	Sound Rejection Coil	85-9651-4
L401	Choke 10uH	15-7528-7
L408 (170)	Width Coil	85-9667-0
L408 (171,172)	Width Coil	85-9792-8
L501	Choke 10uH	15-7528-7
L503	Delay Line I/P Coil	85-9653-0
L504	Delay Line O/P Coil	85-9654-9
L505	Bandpass coil	85-9666-2
LR01/LS01	Choke 10uH	15-7528-7
L506	Sub-carrier coil	85-9651-4
L507	Delay line luminance	15-7581-3
L601	Sound detector coil	85-9650-6
L801	Ferrite bead, FX4016 Mullard	15-7590-2
L802	Choke 3u3H	15-7603-8
L803	Ferrite Bead FX4027	15-7578-3
L805	Choke 22uH	85-1118-7
LR01	Choke 10uH	15-7528-1
LS01	Choke 10uH	15-7528-1
X502	Delay line, chroma	15-7606-2

### 5.1.4 Integrated Circuits.

<u>Cct Ref</u>	<u>Type</u>	<u>Code No.</u>
I001	SAB 3035 Mullard	19-8256-7
I101	TDA 3541 Mullard	19-8049-1
I301	TDA 3651 Mullard	19-8048-3
I401	TDA 2579 Mullard	19-8259-1
I501	TDA 3562A Mullard	19-8275-3
I501	TDA 8190 SGS	19-8153-6
I801	TDA 4601-D Siemens	19-8258-3

### 5.1.7 Transformers

<u>Cct Ref</u>	<u>Description</u>	<u>Code No.</u>
T401	Line Driver Transformer	85-9800-2
T402 $\Delta$	Diode split transformer	85-9845-2
T402 $\Delta$ (170Q, 172Q)	Diode split transformer	85-9846-0
T801 $\Delta$	Switched mode transformer	85-9808-8
T801 $\Delta$ (172QS)	Switched mode transformer	85-9823-1
T801A	Screen can, switched mode transformer	85-4112-4

### 5.1.8 Filters and Crystals

<u>Cct Ref</u>	<u>Description</u>	<u>Code No.</u>
X001	Crystal 4MHz	16-1881-4
X501	Crystal 8.8MHz	16-1901-2
XR01	Ceramic Resonator 4MHz	15-7632-1
XT01 (RC70)	Ceramic Resonator 455kHz	15-7630-5
Z101	S.W. Filter	15-7635-6
Z601	Filter, ceramic - 6MHz	15-6981-3
Z801	Mains Filter - 2 x 39mH	15-7637-2

### 5.1.9 Switches and Connectors

<u>Cct Ref</u>	<u>Description</u>	<u>Code No.</u>
SR01 - SR06	Switch, momentary push-button (6 off)	20-4071-9
SR01A	Button (red)	25-2037-0
SR02A - SR06A	Button (grey) (5 off)	25-2036-2
	$\Delta$ Mains ON/OFF switch	20-4065-4
M401	Connector, 5 way	42-0212-0
M501	Connector, 13-way	22-8162-7
M601	Connector, 2-way	22-8001-9
M801	Connector, 3-way	22-8168-6
M901	Connector, 2-way	42-0211-2
	Tube base socket (170,170Q,172Q)	22-8095-7
	Tube base socket (171, 171Q)	25-1990-9
	Interconnecting lead, chassis/tubebase (170,170Q)	85-4540-5
	Interconnecting lead, chassis/tubebase (171,171Q,172Q)	85-5097-2

## 5.2 Main Chassis and Tube Base Board. (180 Series)

### 5.2.1 Resistors.

The majority of resistors are standard carbon film types, readily available from component stockists. Refer to the circuit diagram for values. Note that unless marked otherwise on the circuit diagram, resistors are either  $\frac{1}{4}$  watt or  $\frac{1}{2}$  watt rated. Replacements should always be of a power rating equal to the originals. This is particularly important for those resistors which are stood off the P.C.B.

<u>Cct Ref</u>	<u>Value</u>	<u>Tolerance</u>	<u>Rating</u>	<u>Type</u>	<u>Code No.</u>
R105	10K	20%	-----	Preset Linear Pot	12-2682-7
R201 $\Delta$	22R	5%	0.5W fusing	Mullard SFR25	11-4803-6
R206,R216, R226	100K	2%	0.5W	Mullard MRS25	11-5266-1
R207,R217 R227	3K3	2%	0.25W	Metal Film	11-5265-3
R209,R219 R229	2K2	2%	0.25W	Metal Film	11-3723-9
R204,R214 R224 $\Delta$	1K	5%	0.5W fusing	Mullard SFR25	11-4292-5
R239	2K0	2%	0.25W	Metal Film	11-4255-0
R240	330R	2%	0.25W	Metal Film	11-5264-5
R308	2K2	20%	-----	Preset Linear Pot	12-2467-0
R302	16K	2%	0.25W	Metal Film	11-3726-3
R303	220K	2%	0.25W	Metal Film	11-4073-6
R313	1K0	20%	-----	Preset Linear Pot	12-2625-8
R316	10K	20%	-----	Preset Linear Pot	12-2682-7
R403	47K	20%	-----	Preset Linear Pot	12-2585-5
R411	4K7	20%	-----	Preset Linear Pot	12-2354-2
R412	33K	2%	0.25W	Metal Film	11-4062-0
R423 (180T)	10R	5%	0.5W	Fusing	11-4266-6
R434,R439	470R	5%	0.5W	Carbon Composition	11-2715-2
R416	100K	20%	-----	Preset Linear Pot	12-2455-7
R433 (180T) $\Delta$	1R2	10%	0.5W fusing	-----	11-5072-3
R437 (180T)	3R9	10%	4W	W/Wound	11-5283-1
R507	22K	20%	-----	Preset Linear Pot	12-4574-0
R516	470R	20%	-----	Preset Linear Pot	12-2461-1
R521	4K7	20%	-----	Preset Linear Pot	12-2354-2
R544	470R	20%	-----	Preset Linear Pot	12-2461-1
R423 $\Delta$	10R	5%	0.5W fusing	-----	11-4266-6



## 5.2.2 (cont'd)

<u>Cct Ref</u>	<u>Value</u>	<u>Tolerance</u>	<u>Voltage</u>	<u>Type</u>	<u>Code No.</u>
C422 (180)	330n	5%	250V	PP	14-5833-7
C422 (T180)	680n	5%	250V	PP	14-6965-7
C423	680n	5%	250V	PP	14-6965-7
C424	1000u	20%	35V	E	14-5617-2
C425	47u	20%	250V	E	14-6707-7
C426	4u7	20%	250V	E	14-6963-0
C428	22n	5%	1kV	PP	14-6951-7
C430	8n2	10%	250V	MP	14-6968-1
C432	1u	20%	250V	E	14-6971-1
C433	6n8	5%	2kV	PP	14-6959-2
C510	470n	5%	63V	MP	14-6964-9
C513	12p	2%	100V	CP	14-6862-6
C527, C528	470n	5%	63V	MP	14-6964-9
C532, C534	12p	2%	100V	CP	14-6862-6
C801 $\Delta$	220n	20%	250V a.c.	MP (class 2)	14-5163-4
C803, C804	1n	20%	2kV	C	14-6937-1
C805	100u	-10%/+30%	385V	E	14-6870-7
C808	10n	5%	400V	MP	14-6842-1
C813	1n5	5%	1.5kV	PP	14-6649-6
C813*	2n2	5%	1.5kV	PP	14-6970-3
C816	10n	5%	400V	MP	14-6842-1
C818 $\Delta$	1n0	20%	400V a.c.	C	14-6949-5
C822	47u	20%	250V	E	14-6707-7
C824	1000u	20%	16V	E	14-3846-8
C825	2200u	20%	35V	E	14-4733-5
C831, C832	1n0	20%	250V a.c.	C	14-6937-1
C901	10u	-20%/+80%	2kV	CD	14-3906-5
CR01	100u	20%	50V	E	14-6858-8
CR05	100u	20%	10V	E	14-6854-5
CS03	100u	20%	10V	E	14-6854-5
CS08	100p	2%	100V	CP	14-6884-7
CT01)	100p	2%	100V	CP	14-6884-7
CR02) - (RC70)	120p	2%	100V	CP	14-6946-0
CT03)	470u	-10%/+75%	6.3V	E	14-4891-9

\* high power stereo version.

## 5.2.3 Coils, Chokes, Ferrite Beads, Delay Lines.

<u>Cct Ref</u>	<u>Description</u>	<u>Code No.</u>
L001/L004	Choke 10uH	15-7528-7
L101	Choke 3u3H	15-7603-8
L102	Choke 10uH	15-7528-8
L103	Tank Coil	85-9802-9
L104	AFC Coil	85-9811-8
L105	Sound Rejection Coil	85-9651-4
L401	Choke 10uH	15-7528-7
L302	E/W Injection Coil, 5mH	85-9863-0
L303	Bridge Coil, 1mH	85-9837-1
L408	Line Linearity Coil	85-9839-8
L501	Choke 10uH	15-7528-7
L503	Delay Line I/P Coil	85-9653-0
L504	Delay Line O/P Coil	85-9654-9
L505	Chroma Bandpass Coil	85-9666-2

5.2.3 (cont'd)

<u>Cct Ref</u>	<u>Description</u>	<u>Code No.</u>
L506	Chroma Trap Coil	85-9651-4
L507	Delay Line, Luminance	15-7581-3
L601	Sound Detector Coil	85-9650-6
L801	Ferrite Bead, FX4016 Mullard	15-7590-2
L802	Choke 3u3H	15-7603-8
L803	Ferrite Bead FX4027	15-7578-3
L805	Choke 22uH	85-1118-7
LR01/LS01	Choke 10uH	15-7528-7
X502	Delay Line, Chroma	15-7606-2

5.2.4 Integrated Circuits.

<u>Cct Ref</u>	<u>Type</u>	<u>Code No.</u>
I001	SAB 3035 Mullard	19-8256-7
I101	TDA 3541 Mullard	19-8049-1
I301	TDA 3654 Mullard	19-8135-8
I401	TDA 2579 Mullard	19-8259-1
I501	TDA 3562A Mullard	19-8275-3
I601	TDA 8190 SGS	19-8153-6
I801	TDA 4601-D Siemens	19-8258-3
I802	LM317T	19-8264-8
I803	L4941	19-8276-1
IR01	MAB 8441 Mullard	19-8254-0
IR02	PCD 8572 General Instruments.	19-8255-9
IS01	SL 486 Plessey	19-8260-5
IT01 (RC70)	SAA3008 Mullard	19-8272-9

5.2.5 Transistors

<u>Cct Ref</u>	<u>Type</u>	<u>Code No.</u>
Q101	BC547	19-8145-5
Q201, Q203	BF422	19-8150-1
Q202	BF423	19-8293-1
Q204, Q206,		
Q207, Q209	BF422	19-8150-1
Q205, Q208	BF423	19-8293-1
Q210	BC557	19-8146-3
Q301, Q302	BC557	19-8146-3
Q303	BD239C	19-7857-8
Q304	BC547	19-8145-5
Q401	BC547	19-8145-5
Q402	BC337	19-8149-8
Q403	S2000 AF Toshiba	19-8261-3
Q404	BC547	19-8145-5
Q501	BC547	19-8145-5
Q601	BC557	19-8146-3
Q801	S2000 AF Toshiba	19-8261-3
Q802	BC547	19-8145-5
QL01, Q102	BC557	19-8146-3
QL03	BC547	19-8145-5
QR01	BC548C	19-8278-8

5.2.1 (cont'd)

Cct Ref	Value	Tolerance	Rating	Type	Code No.
R510, R511	68K	2%	0.25W	Metal Film	11-3344-6
R512	18K	2%	0.25W	Metal Film	11-3516-3
R801	12K	10%	5W	W/Wound	11-5102-9
R802	3R3	10%	4W	W/Wound	11-5105-3
R808	4K7	20%	-----	Preset Linear Pot	12-2354-2
R816	15K	10%	5W	W/Wound	11-5211-4
R803, R804	100K	5%	0.5W	Metal Film	11-5196-7
R813	120K	5%	0.5W	Metal Film	11-5197-5
R814	150K	5%	0.5W	Metal Film	11-5198-3
R816	15K	10%	5W	W/Wound	11-5211-4
R818 $\Delta$	3M3	5%	0.5W	Metal Glaze	11-4294-1
R818* $\Delta$	10M	5%	0.5W	Metal Glaze	11-5263-7
R820 $\Delta$	OR22	10%	0.4Wfusing	Mullard SFR25	11-5071-5
R823	271R	1%	0.25W	Metal Film	11-5217-3
R824	2K37	1%	0.25W	Metal Film	11-5218-1
R807	18K	2%	0.25W	Metal Film	11-3516-3
R901	---	--	-----	PTC Thermistor	11-3569-4
R902	4R7	5%	0.5Wfusing	-----	11-4724-2
R904, R905, R906, R907, R908	1K	10%	0.5W	Carbon Compound	11-2621-0

\* On later chassis

5.2.2 Capacitors

Many of the capacitors are standard off-the-shelf items. Refer to the circuit diagram for values. Replacements must be of the same tolerance and rating as the originals.

The following list details those which may not be readily available from stockists.

Cct Ref	Value	Tolerance	Voltage	Type	Code No.
C004	18p	2%	100V	CP	14-6881-2
C101, C103	4u7	10%	100V	CP	14-6894-4
C111, C112, C114	0p68	+/-0p25	100V	CP	14-6947-9
C118	100p	2%	100V	CP	14-6948-7
C203, C205, C207	47p	5%	50V	C	14-6802-2
C305	2200u	20%	35V	E	14-4733-5
C306	100u	20%	50V	E	14-6858-8
C310	100u	20%	25V	E	14-6856-1
C404	150n	10%	100V	MP	14-6913-4
C408	2n7	1%	63V	P	14-5818-3
C412	330n	10%	100V	MP	14-6967-3
C418	470u	-20%/+50%	35V	E	14-4701-7
C419	330n	10%	100V	MP	14-6967-3
C421	3n3	5%	2kV	PP	14-6961-4

## 5.1.10 Miscellaneous.

<u>Cct Ref</u>	<u>Description</u>	<u>Code No.</u>
F801	Fuse 1.25A, timelag	21-3665-1
F801A	Fuseholder	21-2628-1
	Mains lead	05-3484-0
H001	△ Tuner, UHF (System I)	21-3672-4
H001	△ Tuner, UHF/VHF (System B/G)	21-3663-5
	Prism, infra-red receiver	83-2131-0
	Screening can, infra-red receiver	05-3356-4
	LED display, 7 segment (2 off)	19-8265-6
	Support Moulding, LED p.c.b.	83-2038-1
	pcb (complete) LED and manual controls	05-3271-1
	pcb only, LED and manual controls	83-2120-5
	Moulded switch cover, manual controls	83-2037-3/10100
	Support bracket, on/off switch	83-2132-9
	Spring Clip (Q403, Q801)	57-2813-4
	Clip (I802)	57-2851-7
	Mica insulator (I802)	47-1187-4
	Screening can, switched mode transformer	85-4112-4
	Main chassis (complete) - 170Q	05-3270-3
	Main chassis (complete) - 171	05-3310-6
	Main chassis (complete) - 171Q	05-3311-4
	Main chassis (complete) - 172Q	05-3472-2
	Main chassis (complete) - 172QS	05-3648-2
	Teletext module TT17	05-3278-9
	Teletext module TT17G	05-3880-9
	Remote control (RC70) hand unit (complete)	05-3306-8
	- top cover	83-2052-7/20100
	- base cover	83-2053-5/20100
	- battery cover	83-2094-2/20100
	- membrane	83-2099-3/160100
	- escutcheon	83-2055-1/130110
	- battery contact (double)	85-4063-2
	- battery contact (single)	83-2161-2
	- printed wiring board	83-2130-2

I802	LM317T	19-8264-8
I803	L4941	19-8276-1
IR01	MAB 8441 Mullard	19-8254-0
IR02	PCD 8572 General Instruments	19-8255-9
IS01	SL 486 Plessey	19-8260-5
IT01 (RC70)	SAA3008 Mullard	19-8272-9
5.1.5 Transistors		

<u>Cct Ref</u>	<u>Type</u>	<u>Code No.</u>
Q101	BC547	19-8145-5
Q201,202,203 (170)	BF422	19-8150-1
Q201,202,203 (171,172)	BF787	18-2122-9
Q401	BC547	19-8145-5
Q402	BC337	19-8149-8
Q403	S2000 AF Toshiba	19-8261-3
Q404	BC547	19-8145-5
Q501	BC547	19-8145-5
Q601	BC557	19-8146-3
Q801	S2000 AF Toshiba	19-8261-3
Q802	BC547	19-8145-5
QL01,02	BC557	19-8146-3
QL03	BC547	19-8145-5
QR01	BC548C	19-8278-8
QR02	BC547	19-8145-5
QT01 (RC70)	BC368	19-8283-4

5.1.6 Diodes

<u>Cct Ref</u>	<u>Type</u>	<u>Code No.</u>
D002	ZTK 33	19-3443-0
D301	1N 4003	19-6405-4
D401	BY133	19-8144-7
D402,403	BA159	19-7779-2
D502	1N4148	19-3992-0
D503	C5V65 350mW V. Reg.	19-4952-7
D601,602	1N4148	19-3992-0
D801,802,803,804	BY133	19-8144-7
D805	BA157	19-4028-7
D806	1N4003	19-6405-4
D807	BA157	19-4028-7
D808,810	BA159	19-7779-2
D811	BA157	19-4028-7
D812	BY396	18-2222-5
D813,814	1N4003	19-6405-4
DR01,02	1N4148	19-3992-0
DS01	BPW41 infra-red photo sensitive	19-6905-6
DT01 (RC70)	TLN115 (Toshiba) infra-red emitting	19-8282-6

R513 $\Delta$	10R	5%	0.4W	Mullard SFR25	11-5200-9
R516	470R	20%	----	Preset linear pot	12-2461-1
R521	4K7	20%	----	Preset linear pot	12-2354-2
R544	470R	20%	----	Preset linear pot	12-2461-1
R801	12K	10%	5W	W/W	11-5102-9
R802	3R3	10%	4W	W/W	11-5105-3
R808	4K7	20%	----	Preset linear pot	12-2354-2
R816	15K	10%	5W	W/W	11-5211-4
R818 $\Delta$	3M3	5%	0.5W	Metal Glaze	11-4294-1
R818* $\Delta$	10M	5%	0.5W	Metal Glaze	11-5263-7
R820,821 $\Delta$	OR22	10%	0.5W	Fusing	11-5071-5
R901 $\Delta$	----	----	----	Thermistor	11-3569-4
R902 (170 171) $\Delta$	OR22	10%	0.5W	Fusing	11-5071-5
R902 (172) $\Delta$	1R2	10%	0.5W	Fusing	11-5072-3
R423 $\Delta$	22R	5%	0.5W	Fusing	11-4803-6/P1
R433 $\Delta$ (170)	4R7	5%	-	-	11-5291-2/P1
R433 $\Delta$ (171)	10R	5%	-	-	11-5292-0/P1

\* on later chassis

### 5.1.2 Capacitors

Many of the capacitors are standard off-the-shelf items. Refer to the circuit diagram for values. Replacements must be of the same tolerance and rating as the originals.

The following list details those which may not be readily available from stockists.

Cct Ref	Value	Tolerance	Voltage	Type	Code No.
C004	18p	2%	100V	CP	14-6881-2
C006	220n	10%	63V	MP	14-6834-0
C101,103	4n7	10%	100V	CP	14-6894-4
C102	10n	-20% +80%	63V	CP	14-6892-8
C111	0p68	+/-0p25	100V	CP	14-6947-9
C112	100p	2%	100V	CP	14-6948-7
C114	0p68	+/-0p25	100V	CP	14-6947-9
C118	100p	2%	100V	CP	14-6948-7
C305	1000u	-20%/+50%	35V	E	14-5617-2
C306	100u	20%	50V	E	14-6858-8
C402	220u	20%	16V	E	14-6861-8
C418	470u	-20%/+50%	35V	E	14-4701-7
C421 (170)	6n8	5%	1.5KV	PP	14-6505-6
C421 (170Q,172Q)	6n2	5%	2KV	PP	14-6957-6
C421 (171)	8n2	5%	2KV	PP	14-6383-7
C421 (171Q)	7n5	5%	2KV	PP	14-6917-7
C422 (170,170Q,171)	390n	5%	250V	PP	14-6505-6
C422 (171Q 172)	330n	5%	250V	PP	14-5833-7
C423	1n	20%	250V a.c.	C	14-6937-1
C424	1000u	20%	35V	E	14-5617-2
C425	47u	20%	250V	E	14-6707-7
C426	22u	20%	250V	E	14-6822-7
C502	100u	20%	25V	E	14-6856-1
C513	12p	2%	100V	CP	14-6862-6
C601	470u	20%	25V	E	14-2800-4
C603	220u	20%	25V	E	14-3715-1
C801 $\Delta$	220n	20%	250V a.c.	PP	14-5163-4
C803, 804	1n	20%	2KV	C	14-6937-1
C905	100u	-10%/+30%	385V	E	14-6870-7

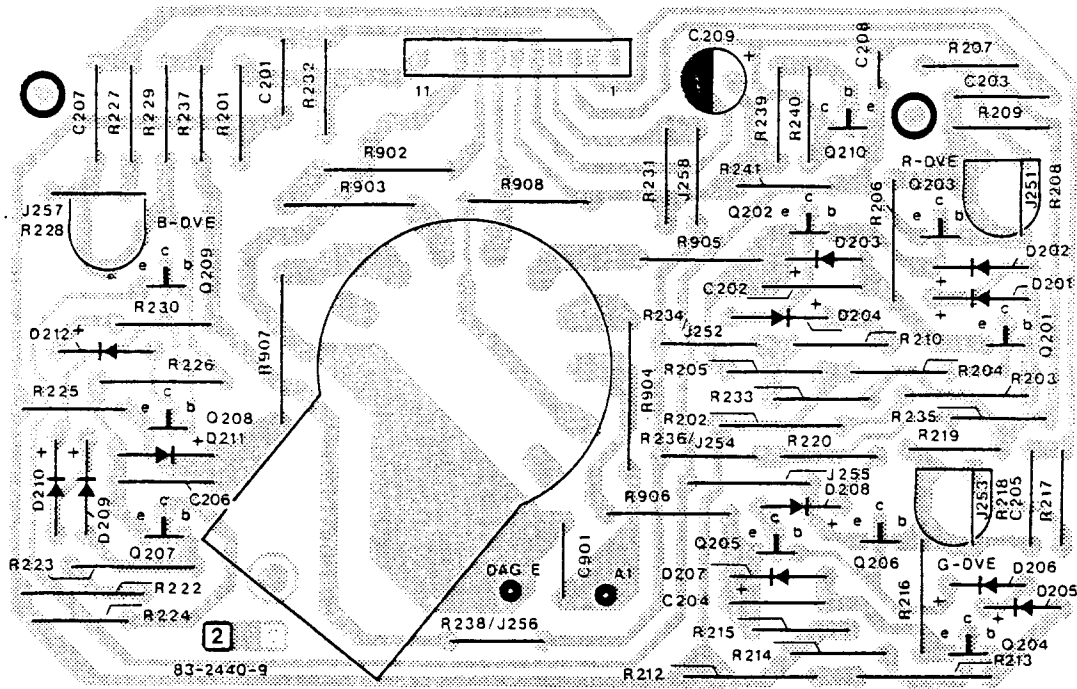

Fig 4.4 180 Series Tube Base p.w.b.

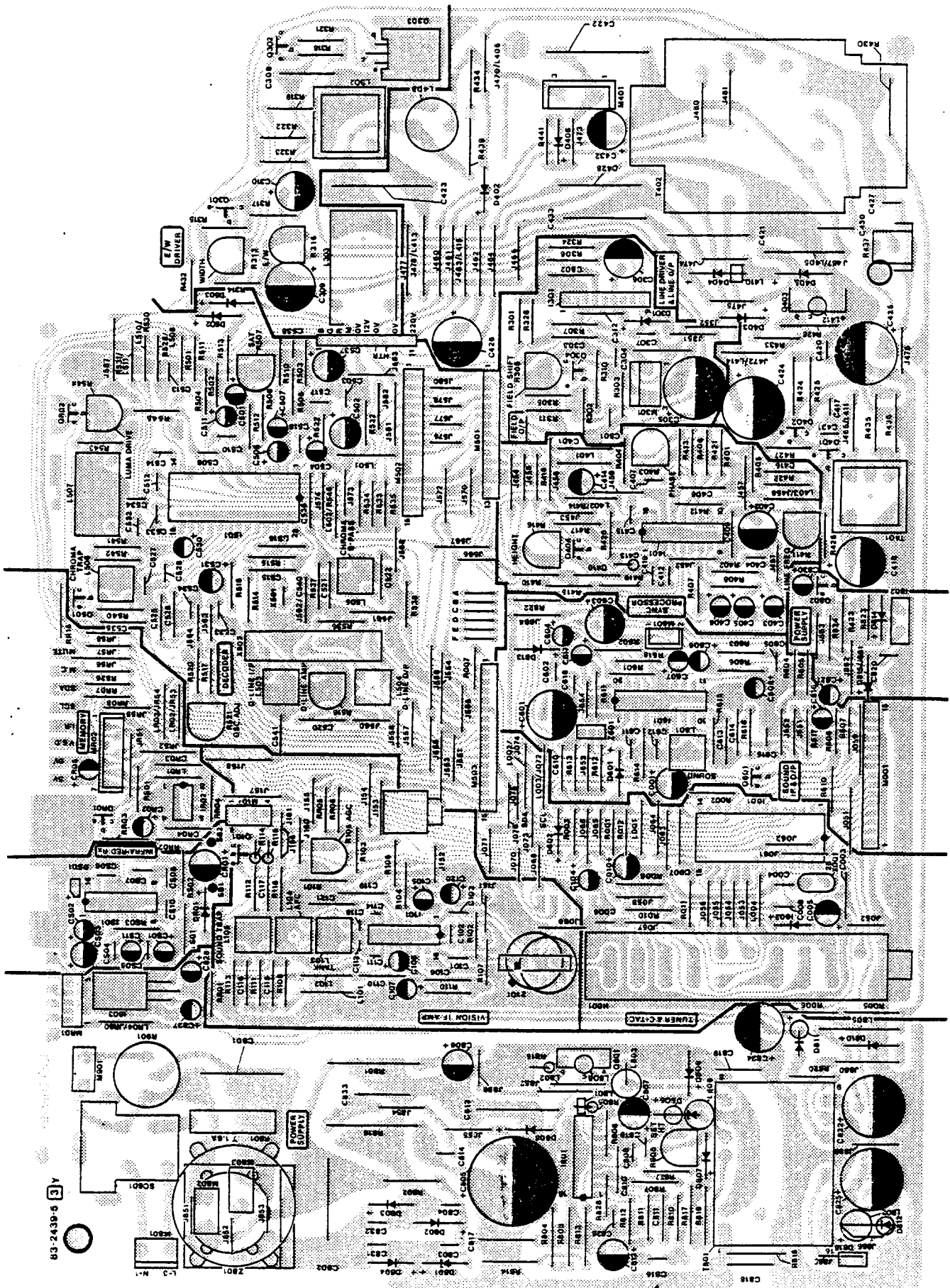

Fig 4.2 (b) 180 Series Main Chassis p.w.b. - component side.



#### 4.10 RGB Board - Setting-up (Non-UK version)

The only adjustment necessary on the RGB board is the setting-up of the Phase Locked Loop (PLL), a circuit which mutes the audio output in the absence of a valid video signal (i.e. no TV or AV).

- (a) Make sure there are no syncs applied to the input of the phase locked loop. This can be achieved by tuning the receiver to an unused channel (ie noise).
- (b) Monitor II02 pin 5 with a frequency counter set to read kHz to 2 decimal places.
- (c) First turn RI22 fully clockwise, then turn anti-clockwise to set the frequency between 15.45 kHz and 15.59 kHz, nominally 15.52 kHz. Check MI01 pin 6 is low (0v).
- (d) Tune the receiver to a valid signal. Check that syncs are applied to the input of the P.L.L. Check that MI01 pin 6 is high (5V).

#### 4.6.1 Luma Drive.

- (a) With a standard colour bar signal displayed NORMALise the contrast and brightness controls.
- (b) Set A1, initially, to the centre of its range.
- (c) Monitor the tube cathodes with an oscilloscope. Adjust A1 until the highest cathode has a black level of 140V +/- 5V.
- (d) Monitor the R,G,B outputs of I501 separately and check that the black levels are all 3.0V +/- 0.5V.
- (e) Set the brightness control to minimum, while maintaining the contrast at mid-position.
- (f) Monitor the R,G,B cathode drives. Adjust R544 until the black-to-white level is 77V +/- 1V
- (g) Check that the blanking level is 175V.

#### 4.6.2 Colour Saturation Adjustment.

- (a) Adjust saturation preset R507 to give approximately 100% saturation on the blue output, I501.
- (b) Check for 100% saturation on red and green outputs.

#### 4.7 Vertical and Horizontal Time-Base Adjustments.

##### 4.7.1 Line Frequency.

- (a) Tune the receiver to a broadcast signal.
- (b) Fit a shorting link between TP41 and TP42.
- (c) Adjust the line frequency control (R411) so that the picture is almost stationary at line rate.
- (d) Remove the shorting link.

##### 4.7.2 Line Phase Control.

Adjust R403 to centralise the picture.

##### 4.7.3 Line Linearity/Width (170 Series).

Adjust L408 to display a picture of correct width with optimum linearity.

#### 4.4 Decoder Alignment

##### 4.4.1 Chroma Bandpass.

- (a) Apply an RF signal modulated with standard colour bars to the aerial socket.
- (b) Connect oscilloscope probe to pin 4, I501 or C536.
- (c) Adjust Chroma bandpass coil, L505, for maximum chroma signal on oscilloscope.

##### 4.4.2 Chroma Trap.

- (a) Maintaining the colour bar input signal, monitor Q501 emitter with an oscilloscope.
- (b) Adjust chroma trap coil, L506, for minimum sub-carrier.

##### 4.4.3 Reference Oscillator.

- (a) Using the TV test signal generator (4.1.2) apply a low level signal of test pattern or colour bars via the aerial input socket.
- (b) Double the colour killer by applying a +12V to pin 5 of I501, i.e. short circuit R503.
- (c) Set R521 to the centre of its range of adjustment which gives colour lock.

##### 4.4.4 Delay Line Input and Output.

- (a) Apply a standard colour bar signal.
- (b) Adjust L503 and L504 for minimum Hanover bars, ensuring that the cores are in similar positions.

##### 4.4.5 Delay Line Amplitude.

- (a) Set the TV Test signal generator to produce a test pattern containing a sign alternate signal. (i.e. alternating B-Y and non-alternating R-Y components).
- (b) Adjust R516 for minimum Hanover bars on the relevant part of the blue output to the tube base.

#### 4.3.3 Tuner AGC Adjustment.

- (a) Connect the signal generator to the aerial input socket.
- (b) Set the TV generator (4.1.2) to a convenient UHF mid-band channel away from strong local transmissions (e.g. channel 45).
- (c) Set the generator modulation to colour bars, with the sound carrier off and an output level of 10mV.
- (d) Tune the receiver to the generator by selecting the appropriate channel with the remote control. (Refer to Section 1, paragraph 1.2 (a). If the channel number of the generator is not known precisely, adopt the 'Search' tuning procedure described in Section 1, paragraph 1.2 (b)).
- (e) Check that the chassis is accurately tuned to the generator by verifying that a correct video waveform is present at the IF output on R116.
- (f) Monitor the IF output of the tuner (i.e. the input to Z101, the S.W.F. Filter) with a 'scope and 10.1 probe of known accuracy at TV IF frequency.
- (g) Synchronise the 'scope at TV line rate.
- (h) Observe the peak-to-peak value of the sync. pulse (i.e. the largest part of the IF envelope).
- (j) Adjust the a.g.c. preset potentiometer R105 to give 1.2V, p-p. across the S.A.W. filter input.
- (k) Disconnect all test equipment from the chassis.

#### 4.3.4 Sound Rejector Alignment.

- (a) Connect the TV signal generator (4.1.2) to the aerial input socket.
- (b) Set the generator to a convenient UHF mid-band channel away from strong local transmissions (e.g. channel 45).
- (c) Set the generator modulation to colour bars, with the sound carrier on, modulated with a 1kHz sinewave at 50kHz deviation.
- (d) Tune the receiver to the generator by selecting the appropriate channel with the remote control (refer to Section 1, para 1.2 (a). If the channel number of the generator is not known precisely, adopt the 'Search' tuning procedure described in Section 1, para 1.2 (b)).
- (e) Check that the chassis is accurately tuned to the generator by verifying that a correct video waveform is present at the IF output on R116.
- (f) Using the 'scope, monitor the video output of the IF on R116.
- (g) Adjust sound rejector coil, L105, for minimum intercarrier signal as seen on the 'scope'.

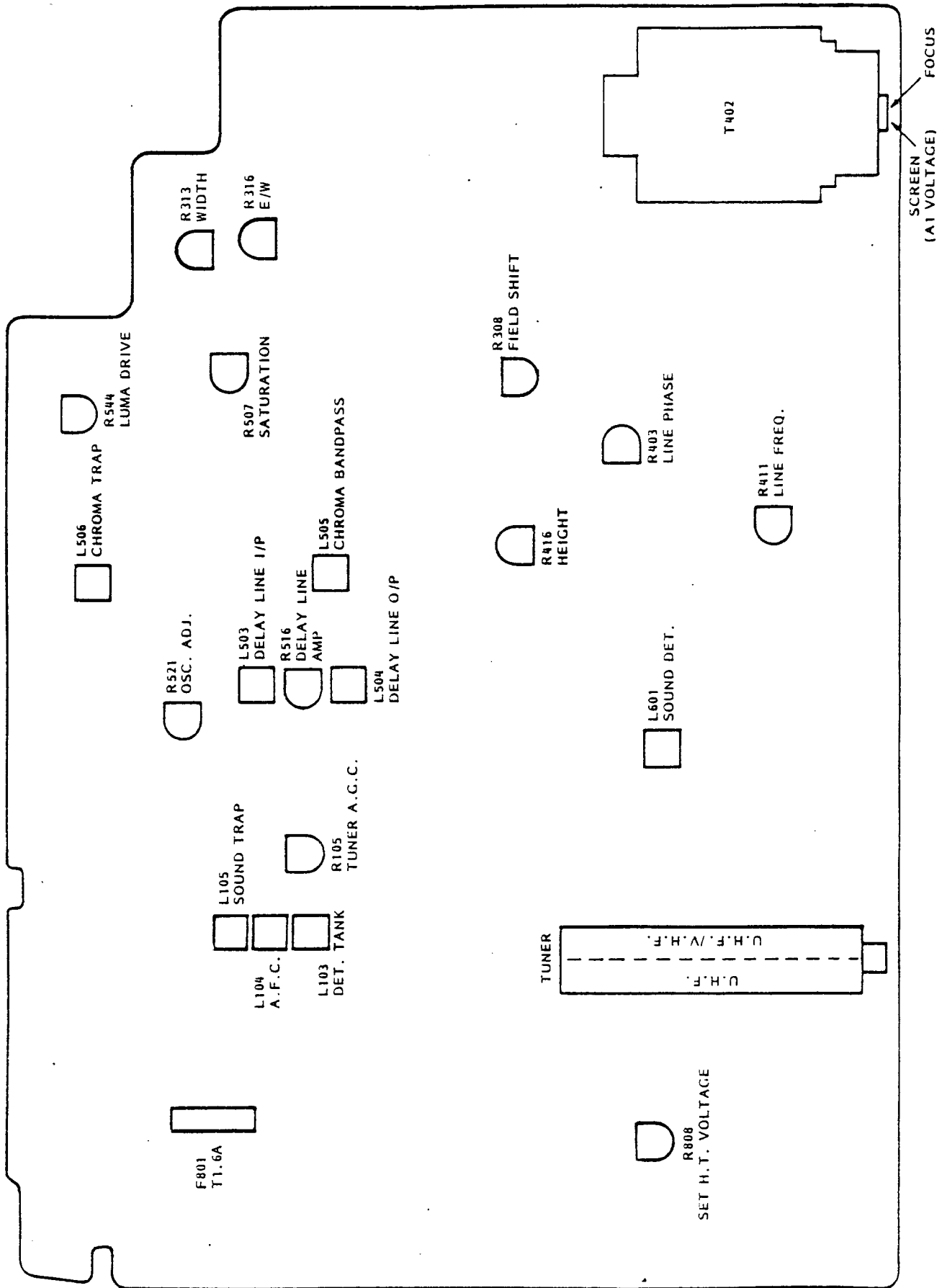

Fig 4.1 b) 180 Series - Location of Adjustments - Main p.c.b.

5.2.5 (cont'd)

<u>Cct Ref</u>	<u>Type</u>	<u>Code No.</u>
QR02	BC547	19-8145-5
QT01 (RC70)	BC368	19-8283-4

5.2.6 Diodes

<u>Cct Ref</u>	<u>Type</u>	<u>Code No.</u>
D002	ZTK 33	19-3443-0
D201 - D212	1N4148	19-3992-0
D301	1N 4003	19-6405-4
D401	BY 133	19-8144-7
D402, D403	BA 159	19-7779-2
D404	BY 228	19-7685-0
D405	BY 399	19-7995-7
D406	BA 157	19-4028-7
D502	1N 4148	19-3992-0
D503	C5V6	19-4952-7
D601, D602	1N 4148	19-3992-0
D801, D802, D803, D804	BY 133	19-8144-7
D805	BA 157	19-4028-7
D806	1N 4003	19-6405-4
D807	BA 157	19-4028-7
D808, D810	BA 159	19-7779-2
D811	BA 157	19-4028-7
D812	BY 396	19-2222-5
D813, D814, D815	1N 4003	19-6405-4
D816	BY 229-200 Mullard	19-8310-5
DR01, DR02	1N 4148	19-3992-0
DS01	BPW41-Infra-red photo sensitive	19-6905-6
DT01 (RC70)	TLN115 (Toshiba)-infra-red emitting	19-8282-6

5.2.7 Transformers.

<u>Cct Ref</u>	<u>Description</u>	<u>Code No.</u>
T401	Line Drive Transformer	85-9852-5
T402	Diode Split Transformer	85-9835-5
T801 $\Delta$	Switched Mode Transformer, mono	85-9834-7
T801 $\Delta$	Switched Mode Transformer, low power stereo	85-9825-8
T801 $\Delta$	Switched Mode Transformer, high power stereo	85-9871-1

5.2.8 Filters and Crystals.

<u>Cct Ref</u>	<u>Description</u>	<u>Code No.</u>
X001	Crystal 4MHz	16-1881-4
X501	Crystal 8.86MHz	16-1901-2
XR01	Ceramic Resonator 4MHz	15-7632-1
XT01 (RC70)	Ceramic Resonator 455KHz	15-7630-5
Z101	S.W. Filter	15-7635-6
Z601	Filter, ceramic - 6MHz	15-6981-3
Z801	Filter, mains - 2 x 39MH	15-7637-2

### 5.3 Teletext Board (if fitted)

#### 5.3.1 Resistors

All fixed resistors on this board are metal film type with 0.125W rating. Refer to the circuit diagram in Fig. 3.8 for values.

RR120 is a 10K ohm pre-set linear potentiometer - code no. 12-2682-7.

#### 5.3.2 Capacitors.

Capacitor types are coded as follows:

<u>Cct Ref</u>	<u>Value</u>	<u>Tolerance</u>	<u>Voltage</u>	<u>Type</u>	<u>Code No.</u>
CR101	10u	20%	50V	E	14-6849-9
CR102,103,105	100n	20%	100V	MP	14-6836-7
CR104	470n	20%	63V	MP	14-6869-3
CR106	10u	20%	50V	E	14-6849-9
CR107	470n	20%	63V	MP	14-6869-3
CR108	68n	20%	100V	MP	14-6835-9
CR110	220p	2%	100V	CP	14-6943-6
CR111	220p	10%	63V	MP	14-6834-0
CR112	47n	20%	100V	MP	14-6879-0
CR113	10u	20%	50V	E	14-6849-9
CR114	47n	20%	100V	MP	14-6879-0
CR115	18p	2%	100V	CP	14-6881-2
CR116	25p	-	----	Trimmer	14-6939-8
CR117	10n	-20%/+80%	63V	CP	14-6892-8
CR118	15p	2%	100V	CP	14-6942-8
CR120	1n	10%	100V	CP	14-6934-7
CR121	470p	10%	100V	CP	14-6940-1
CR122	22n	-10%/+80%	100V	CP	14-6911-8
CR123	270p	2%	100V	CP	14-6944-4
CR124,125	100p	2%	100V	CP	14-6884-7
CR126	27p	2%	100V	CP	14-6886-3
CR127	15p	2%	100V	CP	14-6942-8
CR128,130	100n	20%	100V	MP	14-6836-7
CR131	10u	20%	50V	E	14-6849-9
CR132	100n	20%	100V	MP	14-6836-7
CR133	100u	20%	25V	E	14-6856-1
CR134	1u	20%	50V	E	14-6844-8

#### 5.3.3 Chokes

<u>Cct Ref</u>	<u>Description</u>	<u>Code No.</u>
LR101	Choke 15uH	15-7529-5
LR102	Choke 10uH	15-7528-7
*LR103, LR104	Choke 3u3H	15-7603-0

\* These components replace resistors RR133 and RR134 on export models.

## 5.4 AV Interface Board

### 5.4.1 Resistors

All resistors on this board are metal film type with 0.125W rating. Refer to the circuit diagram in Fig. 3.11 for values.

### 5.4.2 Capacitors

<u>Cct Ref</u>	<u>Value</u>	<u>Tolerance</u>	<u>Voltage</u>	<u>Type</u>	<u>Code No.</u>
CI50,51,52	10u	20%	50V	E	14-6849-9
CI53	100n	20%	100V	MP	14-6836-7
CI54	10u	20%	50V	E	14-6849-9
CI55	100n	20%	100V	MP	14-6836-7
CI56	2n2	20%	50V	E	14-6845-6
CI57	100n	20%	100V	MP	14-6836-7
CI58	10u	20%	50V	E	14-6849-9
CI60,61	10u	20%	50V	E	14-6849-9
CI62	220n	10%	63V	MP	14-6834-0

(non UK only)

### 5.4.3 Integrated Circuits.

<u>Cct Ref</u>	<u>Description</u>	<u>Code No.</u>
II50	4053B	19-8124-2
II51	TEA 2014 Thomson-csf	19-8291-5

### 5.4.4 Transistors

<u>Cct Ref</u>	<u>Description</u>	<u>Code No.</u>
QI50,51,52	BC547	19-8145-5
QI53 (non UK only)	BC557	19-8146-3

### 5.4.5 Diodes

<u>Cct Ref</u>	<u>Description</u>	<u>Code No.</u>
DI50 (non UK only)	1N4531 Mullard	19-8297-1
DI51	1N4531 Mullard	19-8297-1
DI52 (UK only)	1N4531 Mullard	19-8297-1

### 5.4.6 Connectors

<u>Cct Ref</u>	<u>Description</u>	<u>Code No.</u>
MI50	21-way (Euroconnector) socket	22-8171-6
MI51	7-way plug	22-8172-4
MI52	15-way socket	22-8165-1
MI53	4-way plug	22-8173-2



## 5.6 SECAM Transcoder Board

### 5.6.1 Resistors.

All resistors on this board are carbon film types with 0.25W rating. Refer to the circuit diagram in Fig 3.13 for values.

R551 is a 1K ohm preset linear potentiometer - Code No. 12-2625-8

### 5.6.2 Capacitors

<u>Cct Ref</u>	<u>Value</u>	<u>Tolerance</u>	<u>Voltage</u>	<u>Type</u>	<u>Code No.</u>
C551	180p	5%	63V	P	14-2786-5
C552,553	100n	20%	100V	MP	14-6836-7
C554	82p	2%	100V	CP	14-6953-3
C555	470p	10%	100V	CP	14-6940-1
C556	10u	20%	50V	E	14-6849-9
C557,558	100n	20%	100V	MP	14-6836-7
C560	390p	5%	63V	P	14-4412-3
C561	100n	20%	100V	CP	14-6836-7
C562	100p	2%	100V	CP	14-6884-7
C563	22n	30%	15V	TC	14-6813-8
C564	56p	5%	50V	TC	14-6609-7
C565	100u	20%	25V	E	14-6856-1
C566	1u	20%	50V	E	14-6844-8
C567,568	4n7	10%	100V	CP	14-6894-4
C570,571	22n	30%	16V	TC	14-6813-8

### 5.6.3 Inductors, Delay Lines.

<u>Cct Ref</u>	<u>Description</u>	<u>Code No.</u>
L551	Coil, Cloche filter	85-9831-2
L552	Coil, Demodulator	85-9832-0
L553	Choke, 10uH	15-7528-7
X551	Luma Delay Line, 45nS	15-7601-1

### 5.6.4 Integrated Circuits, Transistors, Diodes.

<u>Cct Ref</u>	<u>Description</u>	<u>Code No.</u>
I551	Integrated circuit - TDA3590A N9 Mullard	19-8288-5
Q551,552	Transistors - BC547	19-8145-5
D551	Diode - 1N4148	19-3992-0

### 5.6.5 Connectors

<u>Cct Ref</u>	<u>Description</u>	<u>Code No.</u>
M553	15-way socket	22-8165-1

## 5.8 Stereo IF and Demodulator Board.

### 5.8.1 Resistors.

With the exception of the items listed below, all resistors on this board are standard  $\frac{1}{8}$  watt, 5% carbon or metal film types. Refer to the circuit diagram in Fig.3.17 for values.

<u>Cct Ref</u>	<u>Description</u>	<u>Code No.</u>
R607,608	Linear pot. 22K 20% Preset	12-4574-0
R620,623	Linear pot. 470R 20% Preset	12-2461-1

### 5.8.2 Capacitors.

<u>Cct Ref</u>	<u>Value</u>	<u>Tolerance</u>	<u>Voltage</u>	<u>Type</u>	<u>Code No.</u>
CI601	10n	20%	400V.	MP	14-6838-3
CI602	100u	20%	25V	E	14-6856-1
CI604	47u	20%	25V	E	14-6853-7
CI605	22n	10%	250V	MP	14-6877-4
CI606	47n	20%	100V	MP	14-6879-0
CI607	1u0	5%	63V	P	14-2790-3
CI608	4n7	10%	100V	CP	14-6894-4
CI610,611	4u7	20%	50V	E	14-6846-4
CI612,613	47n	20%	100V	MP	14-6879-0
CI614	100u	20%	25V	E	14-6856-1
CI615	0u47	20%	50V	E	14-6863-4
CI616,617	100n	20%	100V	MP	14-6836-7
CI618,620	220n	10%	63V	MP	14-6834-0
CI621,622	0u47	20%	50V	E	14-6863-4
CI623	47u	20%	25V	E	14-6853-7
CI624	1n0	10%	50V	TC	14-6803-0
CI625	4n7	5%	63V	P	14-4294-5
CI626	1n0	5%	63V	P	14-2790-3
CI627	1n0	10%	100V	CP	14-6934-7
CI628	47n	20%	100V	MP	14-6879-0
CI630	22n	10%	250V	MP	14-6877-4
CI631	1u0	20%	50V	E	14-6844-8
CI632-634	4n7	10%	100V	CP	14-6894-4

### 5.8.3 Transistors and Integrated Circuits.

<u>Cct Ref</u>	<u>Description</u>	<u>Code No.</u>
QI601, 602	Transistor BC547	19-8145-5
II601	Integrated circuit TDA 2556 Mullard	19-8302-4
II602	Integrated circuit TDA 3803 Mullard	19-8303-2

### 5.9.5 Connectors

<u>Cct Ref</u>	<u>Description</u>	<u>Code No.</u>
MI50	21-way Socket (Euroconnector)	22-8171-6
MI51	7-way plug	22-8172-4
MI52	15-way socket	22-8165-1
MI53	4-way Plug	22-8173-2
MI54	12-way plug	22-8177-5
MI55	5-way socket	22-8186-4

### 5.10 Stereo Power Amplifier Board (5 Watts)

#### 5.10.1 Resistors

The majority of resistors on this board are standard  $\frac{1}{2}$  watt, 5% carbon or metal film types. Refer to the circuit diagram in Fig. 3.19 for values. Other types are listed below.

<u>Cct Ref</u>	<u>Value</u>	<u>Tolerance</u>	<u>Wattage</u>	<u>Type</u>	<u>Code No.</u>
*RA16	4R7	5%	7W	W/W	11-5268-8
+RA16	3R3	5%	7W	W/W	11-5271-8
RA24,25	10R	5%	0.5W	Fusible	11-4266-6
+RA54,55	220R	5%	0.5W		11-2642-3

#### 5.10.2 Capacitors

<u>Cct Ref</u>	<u>Value</u>	<u>Tolerance</u>	<u>Voltage</u>	<u>Type</u>	<u>Code No.</u>
CA01,02	22n	10%	250V	MP	14-6877-4
CA03	100n	20%	100V	MP	14-6836-7
CA04,05	10u	20%	50V	E	14-6849-9
CA06	15n	20%	400V	MP	14-6933-9
CA07	2u2	20%	50V	E	14-6845-6
CA08	68n	20%	100V	MP	14-6835-9
CA10	100u	20%	25V	E	14-6856-1
CA11	220n	20%	63V	MP	14-6834-0
CA12	68n	20%	100V	MP	14-6835-9
CA13	15n	20%	400V	MP	14-6933-9
CA14	2u2	20%	50V	E	14-6845-6
CA15	10u	20%	50V	E	14-6849-9
CA16	15n	20%	400V	MP	14-6933-9
CA17	1u0	20%	50V	E	14-6844-8
CA18	10u	20%	50V	E	14-6849-9
CA20	15n	20%	400V	MP	14-6933-9
CA21	1u0	20%	50V	E	14-6844-8
CA22	2200u	20%	35V	E	14-4733-5
CA23	100n	20%	100V	MP	14-6836-7
CA24,25	22n	10%	250V	MP	14-6877-4
CA26,27	1000u	20%	35V	E	14-5617-2
CA28	47u	20%	25V	E	14-6853-7
CA30	10u	20%	50V	E	14-6849-9
CA31-34,CA43	100n	20%	100V	MP	14-6836-7
CA44	100u	20%	25V	E	14-6856-1

## 5.11 Stereo Power Amplifier Board (15 watts)

### 5.11.1 Resistors.

The majority of resistors on this board are standard  $\frac{1}{4}$ W, 5% carbon or metal film type. Refer to the circuit diagram in Fig. 3.20, for values. Other types are listed below.

<u>Cct Ref</u>	<u>Value</u>	<u>Tolerance</u>	<u>Wattage</u>	<u>Type</u>	<u>Code No.</u>
RA16	4R7	5%	7W	W/W	11-5268-8
RA24,25	1R0	5%	0.5W	Fusible	11-4268-2
*RA50	4R7	5%	7W	W/W	11-5268-8
+RA50	3R9	5%	7W	W/W	11-5278-5
RA54,55	220R	5%	0.5W		11-2642-3

### 5.11.2 Capacitors

<u>Cct Ref</u>	<u>Value</u>	<u>Tolerance</u>	<u>Wattage</u>	<u>Type</u>	<u>Code No.</u>
CA01,02	22n	10%	250V	MP	14-6877-4
CA03	100n	20%	100V	MP	14-6836-7
CA04,05	10u	20%	50V	E	14-6849-9
CA06	15n	20%	400V	MP	14-6933-9
CA07	2u2	20%	50V	E	14-6845-6
CA08	68n	20%	100V	MP	14-6835-9
CA10	100u	20%	25V	E	14-6856-1
CA11	220n	20%	63V	MP	14-6834-0
CA12	68n	20%	100V	MP	14-6835-9
CA13	15n	20%	400V	MP	14-6933-9
CA14	2u2	20%	50V	E	14-6845-6
CA22	2200u	20%	35V	E	14-4733-5
CA23-25	100n	20%	100V	MP	14-6836-7
CA26,27	1000u	20%	35V	E	14-5617-2
CA28	47u	20%	25V	E	14-6853-7
CA30	10u	20%	50V	E	14-6849-9
CA31-34	100n	20%	100V	MP	14-6836-7
CA35,36	1u0	20%	50V	E	14-6844-8
CA37,38,40	4u7	20%	50V	E	14-6846-4
CA41,42	1u0	10%	100V	CP	14-6934-7
CA43	100n	20%	100V	MP	14-6836-7

### 5.11.3 Transistors and Integrated Circuits.

<u>Cct Ref</u>	<u>Description</u>	<u>Code No.</u>
QA01,02	Transistor BC547	19-8145-5
IA01	Integrated circuit LM348N	19-7269-3
IA02	Integrated circuit 4053B	19-8124-2
IA03	Integrated circuit TDA1524A	19-8298-2

TO M502  
MAIN P.W.B.

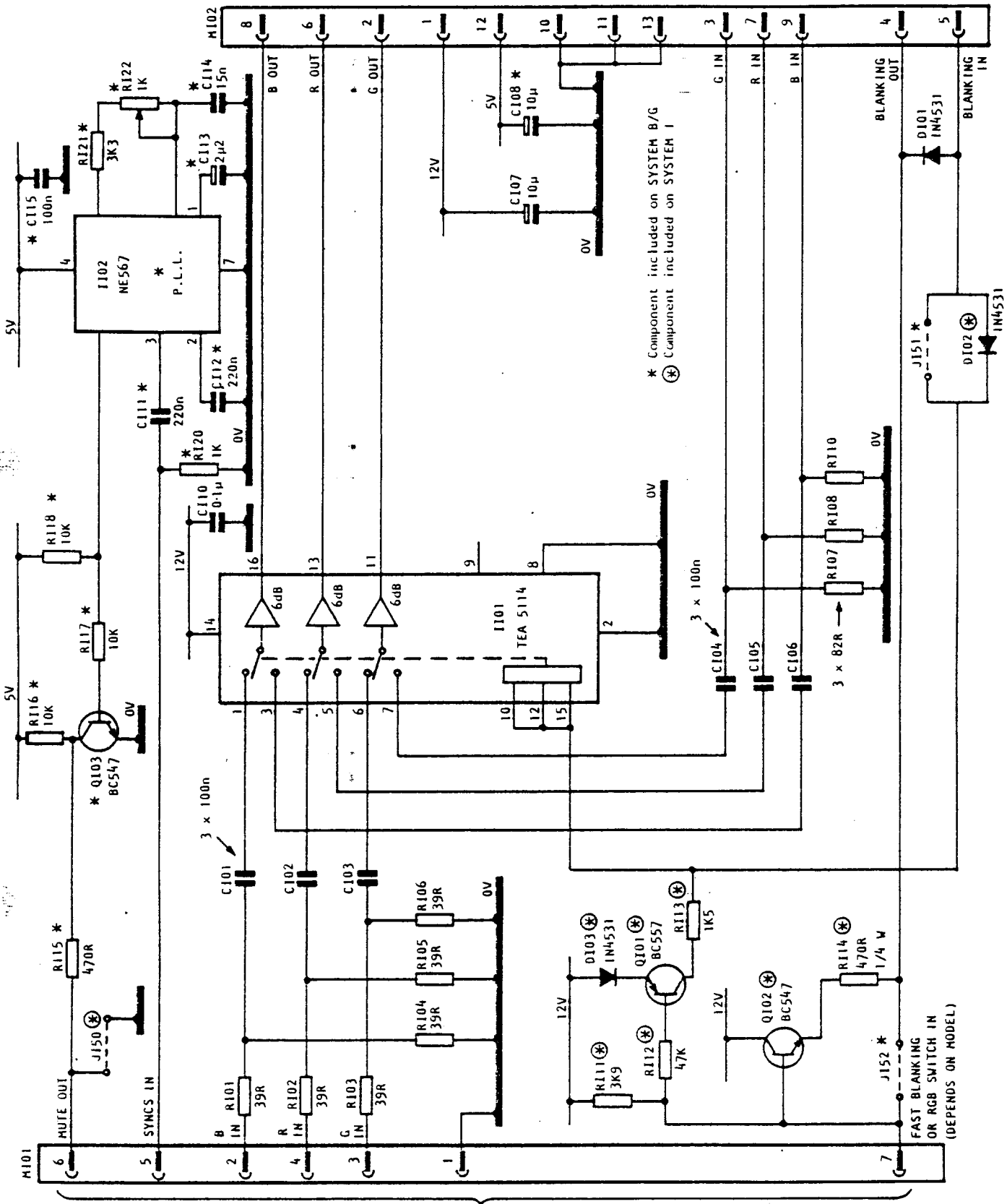

\* Component included on SYSTEM B/G  
⊗ Component included on SYSTEM I

To M151  
on AV P.W.B.

Fig 3.12 RGB Interface Board - Circuit Diagram

### 3.6 SECAM Transcoder Board

Read the following circuit description in conjunction with Fig. 3.13.

The SECAM processor I.C. (TDA3590A) is used in conjunction with the PAL decoder (TDA3562A) to provide colour decoding of both SECAM and PAL encoded signals. The TDA3590A converts SECAM signals into sequential phase modulated (quasi - PAL) signals which are then decoded by TDA3562A.

#### 3.6.1 System Identification

System identification is achieved jointly between the two I.C.'s as a function of the voltages applied to pins 1 and 6 of TDA3590A. Pin 1 voltage level is controlled by the PAL/PAL detection of TDA3562A. Pin 6 voltage level is function of SECAM/SECAM detection by TDA3590A.

The system operates on the principle of PAL/PAL as follows:-

- (i) Channel switching - pin 6 high (SECAM) mode of TDA3590A.
- (ii) PAL signal - pin 6 high. TDA3562A recognises a PAL signal and forces pin 1 to between 0.5V and 2.6V. The system locks in PAL mode.
- (iii) SECAM signal - initial high voltage at pin 6 sets TDA3590A in SECAM mode. TDA3562A recognises a PAL signal, forcing the voltage at pin 1 to 0.4V. This in turn causes a fall in the voltage level at pin 6. TDA3562A therefore detects a SECAM signal and locks the system in the SECAM mode.
- (iv) Monochrome signal - the initial high voltage at pin 6 of TDA3590A indicates a SECAM mode. THE TDA3562A detects a PAL mode. The resultant voltages at pins 1 and 6 of TDA3590A cause operation of the system colour killer circuit.

#### 3.6.2 Signal Processing

Composite video, whether derived from PAL or SECAM encoded signal, is fed to pins 4 and 16 of TDA3590A.

- (i) SECAM composite video is fed via a cloche filter (tuned to 4.286 MHz) to pin 4, and as Luma via a 450ns delay line to pin 16. The signals at pin 4 are amplified and limited, and then demodulated by the tuned circuit connected across pins 23 and 24. The demodulated signal emerges at pin 8 in the form of alternate R-Y and B-Y colour difference signals. Luma information emerges at pin 15.
- (ii) PAL and monochrome composite video signals are diverted via pin 16 to the Chroma output at pin 8.

5.11.4 Chokes, Diodes.

<u>Cct Ref</u>	<u>Description</u>	<u>Code No.</u>
LA02,03	Choke 6u8H, High current	15-7642-9
DA01,02	Diode 1N4148	19-3992-0
DA03-06	Diode 1N4003GP	19-6405-4
DA07,08	Diode 1N4148	19-3992-0

5.11.5 Connectors.

<u>Cct Ref</u>	<u>Description</u>	<u>Code No.</u>
MA01	12-way plug	22-8179-1
MA02	2-way plug	22-8180-5
MA03	2-way plug	22-8007-8
MA04	2-way plug	22-8001-9
MA05,06	2-pin DIN	22-8181-3
+MA07	Headphone jack socket	22-8185-6

5.11.6 Miscellaneous

<u>Cct Ref</u>	<u>Description</u>	<u>Code No.</u>
	Heatsink - stereo o/p integrated circuit	05-3680-6
*FA01	Fuse - 1A Fastblow	21-3670-8
+FA01	Fuse - 1.25A Fastblow	21-3671-6

5.10.3 Transistors and Integrated Circuits.

<u>Cct Ref</u>	<u>Description</u>	<u>Code No.</u>
QA01,02	Transistor BC547	19-8145-5
IA01	Integrated circuit - LM348N	19-7269-3
IA02	Integrated circuit - 4053B	19-8124-2
IA03	Integrated circuit - TDA1524A	19-8298-2

5.10.4 Chokes, Diodes.

<u>Cct Ref</u>	<u>Description</u>	<u>Code No.</u>
+LA02,03	Choke 6u8H, High current	15-7642-9
DA01,02	Diode 1N4148	19-3992-0

5.10.5 Connectors

<u>Cct Ref</u>	<u>Description</u>	<u>Code No.</u>
MA01	12-way plug	22-8179-1
MA02	2-way plug	22-8180-5
MA03	2-way plug - black Pressac	22-8007-8
MA04	2-way plug - white Pressac	22-8001-9
+MA07	Headphone jack socket	22-8185-6

5.10.6 Miscellaneous

<u>Cct Ref</u>	<u>Description</u>	<u>Code No.</u>
	Heatsink - stereo output integrated circuit	05-3650-4
*FA01	Fuse - 1A Fastblow	21-3670-8
+FA01	Fuse - 1.25A Fastblow	21-3671-6



#### 5.8.4 Chokes, Coils, Filters

<u>Cct Ref</u>	<u>Description</u>	<u>Code No.</u>
LI601	Choke 10uH	15-7538-7
LI602	Coil-stereo 38.9 MHz	85-9829-0
LI603, 605	Coil-stereo Sound Detector	85-9830-4
LI604	Coil - 54.7kHz stereo identification	85-9844-4
ZI601	Ceramic Filter - 5.5 MHz	15-7643-7
ZI602	Ceramic Filter - 5.74 MHz	15-7639-9

#### 5.8.5 Connectors

<u>Cct Ref</u>	<u>Description</u>	<u>Code No.</u>
MI601	3-way plug	22-8187-2
MI602	5-way plug	22-8176-7

### 5.9 Stereo AV Interface Board

#### 5.9.1 Resistors

All resistors on this board are standard  $\frac{1}{8}$  watt 5% carbon or metal film types. Refer to the circuit diagram in Fig. 3.18 for values.

#### 5.9.2 Capacitors

<u>Cct Ref</u>	<u>Values</u>	<u>Tolerance</u>	<u>Voltage</u>	<u>Type</u>	<u>Code No.</u>
CI50-58, CI60	10u	20%	50V	E	14-6849-9
CI61	2u2	20%	50V	E	14-6845-6
CI62	100n	20%	100V	MP	14-6836-7
CI63	220n	10%	63V	MP	14-6834-0
CI64	100n	20%	100V	MP	14-6836-7
CI65,66	10u	20%	50V	E	14-6849-9
CI67	100n	20%	100V	MP	14-6836-7
CI68,70	47n	20%	100V	MP	14-6879-0

#### 5.9.3 Transistors and Integrated Circuits.

<u>Cct Ref</u>	<u>Description</u>	<u>Code No.</u>
QI51-54	Transistor BC547	19-8145-5
QI55	Transistor BC557	19-8146-3
II50	Integrated circuit - 4053	19-8124-2
II51	Integrated circuit - 2014	19-8291-5

#### 5.9.4 Diodes

<u>Cct Ref</u>	<u>Description</u>	<u>Code No.</u>
DI50, 51	Diode 1N4148	19-3992-0

## 5.7 Spatial Sound Av Interface Board.

### 5.7.1 Resistors.

All resistors on this board are standard  $\frac{1}{8}$  watt, 5% carbon or metal film types. Refer to the circuit diagram in Fig 3.15. for values.

### 5.7.2 Capacitors.

<u>Cct Ref</u>	<u>Value</u>	<u>Tolerance</u>	<u>Voltage</u>	<u>Type</u>	<u>Code No.</u>
CI50-58					
CI60,65,66	10u	20%	50V	E	14-6849-9
CI61	2u2	20%	50V	E	14-6845-6
CI62,64,67	100n	20%	100V	MP	14-6836-7

### 5.7.3 Transistors and Integrated Circuits.

<u>Cct Ref</u>	<u>Description</u>	<u>Code No.</u>
QI50-54	Transistor BC547	19-8145-5
II50	Integrated Circuit - 4053B	19-8124-2
II51	Integrated Circuit - TEA2014	19-8291-5

### 5.7.4 Diodes

<u>Cct Ref</u>	<u>Description</u>	<u>Code No.</u>
DI51	1N4531 Mullard	19-8279-1
DI52	1N4148 Mullard	19-3992-0

### 5.7.5 Connectors.

<u>Cct Ref</u>	<u>Description</u>	<u>Code No.</u>
MI50	21-way socket (Euroconnector)	22-8171-6
MI51	7-way plug	22-8172-4
MI52	15-way socket	22-8165-1
MI53	4-way plug	22-8173-2
MI54	12-way plug	22-8177-5

## 5.5 RGB Interface Board.

### 5.5.1 Resistors

All fixed resistors on this board are metal film types with 0.125W rating. Refer to the circuit diagram in Fig 3.12 for values.

RI22 is a 1K ohm preset linear potentiometer - code no. 12-2625-8

### 5.5.2 Capacitors

<u>Cct Ref</u>	<u>Value</u>	<u>Tolerance</u>	<u>Voltage</u>	<u>Type</u>	<u>Code No.</u>
CI01 to CI06	100n	20%	100V	MP	14-6836-7
CI07	10u	20%	50V	E	14-6849-9
CI08 non UK only	10u	20%	50V	E	14-6849-9
CI10	100n	20%	100V	MP	14-6836-7
CI11,12 " "	220n	10%	63V	MP	14-6834-0
CI13 non UK only	2n2	20%	50V	E	14-6845-6
CI14 non UK only	15n	10%	400V	MP	14-6933-9

### 5.5.3 Integrated Circuits

<u>Cct Ref</u>	<u>Description</u>	<u>Code No.</u>
II01	TEA 5114	19-8292-3
II02 Non UK only	NE567 Mullard	19-8295-8

### 5.5.4 Transistors

<u>Cct Ref</u>	<u>Description</u>	<u>Code No.</u>
QI01 (UK only)	BC557	19-8146-3
QI02 (UK only)	BC547	19-8145-5
QI03 (Non UK only)	BC547	19-8145-5

### 5.5.5 Diodes

<u>Cct Ref</u>	<u>Description</u>	<u>Code No.</u>
DI01	1N4531	19-8279-6
DI02,03 UK only	1N4531	19-8279-6

### 5.5.6 Connectors.

<u>Cct Ref</u>	<u>Description</u>	<u>Code No.</u>
MI01	7-way plug	22-8172-4
MI02	15-way socket	22-8165-1

#### 5.3.4 Integrated Circuits.

<u>Cct Ref</u>	<u>Description</u>	<u>Code No.</u>
IR101	SAA5231 - Mullard	19-8266-4
IR102	SAA5240A - Mullard	19-8267-2
IR103	TMM2015BP - Toshiba	19-8269-9
IR104	MAB8441T049 - Mullard	19-8268-0

#### 5.3.5 Transistors

<u>Cct Ref</u>	<u>Description</u>	<u>Code No.</u>
QR101-108	BC547	19-8145-5
QR110	BC557	19-8146-3
QR111	BC337	19-8149-8

#### 5.3.6 Diodes

<u>Cct Ref</u>	<u>Description</u>	<u>Code No.</u>
D101-103	1N4531 Mullard	19-8279-6

#### 5.3.7 Crystals and Resonators

<u>Cct Ref</u>	<u>Description</u>	<u>Code No.</u>
XR101	Ceramic Resonator 6MHz	15-7634-8
XR102	Crystal 13.875 MHz	16-1913-6
XR103	Ceramic Resonator 4MHz	15-7632-1

#### 5.3.8 Connectors

<u>Cct Ref</u>	<u>Description</u>	<u>Code No.</u>
MR101	13-way socket	22-8160-0

### 5.2.9 Switches and Connectors

<u>Cct Ref</u>	<u>Description</u>	<u>Code No.</u>
SR01 - SR06	Switch, momentary push button (6 off)	20-4071-9
SR01A	Button (red)	25-2037-0
SR02A - SR06A	Button (grey) (5 off)	25-2036-2
	⚠ Mains ON/OFF switch	20-4065-4
M201	Connector, 11-way	22-8178-3
M301(T180)	Connector, 3-way	22-8168-5
M401(T180)	Connector, 3-way	22-6114-6
M501	Connector, 13-way	22-8162-7
M601	Connector, 2-way	22-8001-9
M801	Connector, 3-way	22-8168-6
M901	Connector, 2-way	42-0211-2
	Tube base socket	22-1990-9
	Interconnecting lead, chassis/tubebase	83-2457-3
	Interconnecting lead, chassis/scan coils (180)	05-3547-8
	Interconnecting lead, chassis/scan coils (T180) - (Line)	05-3813-2
	- (Field)	05-3814-0

### 5.2.10 Miscellaneous.

<u>Cct Ref</u>	<u>Description</u>	<u>Code No.</u>
F801⚠	Fuse 1.6A, timelag	21-2074-0
F801A	Fuseholder	21-2628-1
	Mains lead	05-3484-0
H001⚠	Tuner, UHF (System I)	21-3672-4
H001⚠	Tuner, UHF/VHF (System B/G)	21-3663-5
	Prism, infra-red receiver	83-2131-0
	Screening can, infra-red receiver	05-3356-4
	LED display, 7-segment (2 off)	19-8265-6
	Support moulding, LED p.c.b	83-2038-1
	pcb (complete) LED and manual controls	05-3271-1
	pcb only, LED and manual controls	83-2120-5
	Moulded switch cover, manual controls	83-2037-3/10100
	Support bracket, on/off switch	83-2132-9
	Spring clip (Q403, Q801)	57-2813-4
	Clip (I802)	57-2851-7
	Mica Insulator (I802)	47-1187-4
	Screening can, switched mode transformer	85-4112-4
	Main chassis (complete) - 180	05-3747-0
	Main chassis (complete) - T180	05-3718-7
	Tube base (complete)	05-3541-9
	Heatsink (Q303)	83-2522-7
	Teletext module(TT17)	05-3278-9
	Teletext module(TT17G)	05-3880-9
	Remote control (RC70) Hand Unit (complete)	05-3306-8
	- top cover	83-2052-7/20100
	- base cover	83-2053-5/20100
	- battery cover	83-2094-2/20100
	- membrane	83-2099-3/160100
	- escutcheon	83-2055-1/130110
	- battery contact (double)	85-4063-2
	- battery contact (single)	83-2161-2
	- printed wiring board	83-2130-2

### 3.1 RC70 Remote Control Hand Unit (Infra-red Transmitter)

The RC70 Remote Control Hand Unit is a self-contained battery operated device. Refer to the circuit diagram shown in Fig. 3.1. when reading the following description.

The infra-red transmitter consists of a single i.c. which contains all the circuitry required to scan the rubber membrane keyboard and produce a series of pulses to drive the infra-red transmitting diode.

In the rest state, with no keys depressed, the drive lines (pins 13 to 19, IT01) are held in the 'low' state and the sense lines (pins 2 to 9, IT01) are held in a 'high' state by internal pull-up devices. If a key on the matrix is closed then the key position is detected and the corresponding command code is produced at the transmitter output (pin 1, IT01).

The command generated by IT01 is a sequence of 12 pulses which define 11 periods. It is the period which denotes a binary '0' or '1' to represent the command as a binary code - Fig 3.2 gives details of the output format. Each of the twelve pulses consists of a burst of 38 kHz carrier frequency and the pulse duration is 5.06ms to denote a logic '0' or 7.59ms for logic '1'. The periods between the pulses represent, in order of transmission, the start bit, a toggle bit, three system address bits, and the six-bit command code. The start bit and the system address bits always have the same duration regardless of the command used. The toggle bit changes state when a new command is detected. The six bits for each command are shown in Table 3.1.

The transmitter i.c. is capable of generating 1280 commands but in this system the valid commands are restricted to 48 (or less depending on the particular model).

#### Direct Channel Selection:

When the channel number required is directly entered from the remote control unit the Tuning Microcomputer (IRO1) calculates the CCIR vision-carrier frequency for the channel and begins the 'in-channel search' (described earlier). If a valid TV signal is not found within this channel the CCIR frequency is re-tuned (after the microstep search) and tuning is aborted.

#### Full Search:

The 'Search' key on the local keypad initiates a search throughout all the valid channels (21-69 system I: 1-69, 74-78, 80-99 system B/G) until a TV signal is found. On depression of the search key, IRO1 calculates the next microstep above the current frequency and the 'in channel search' begins from this point upwards. Note: channels at lower frequencies, and microstep frequencies within the same channel but below the prevailing frequency at the start of the search, are not checked at this point. These will be searched only after the higher frequency microsteps of the prevailing channel, and higher frequency channels have been scanned as per the following description.

If a valid signal is not found within the current channel limits the search continues in the next (higher) channel where the full 'in channel search' is used. The process is repeated until a valid signal is found or until search-tuning is aborted by a remote-control command (e.g. programme number entry). In the event that the search reaches the top limit of the band, without finding a signal, then the search re-starts at the lowest valid channel for the tuning system. Full search continues until a signal is located, or until aborted by a remote command.

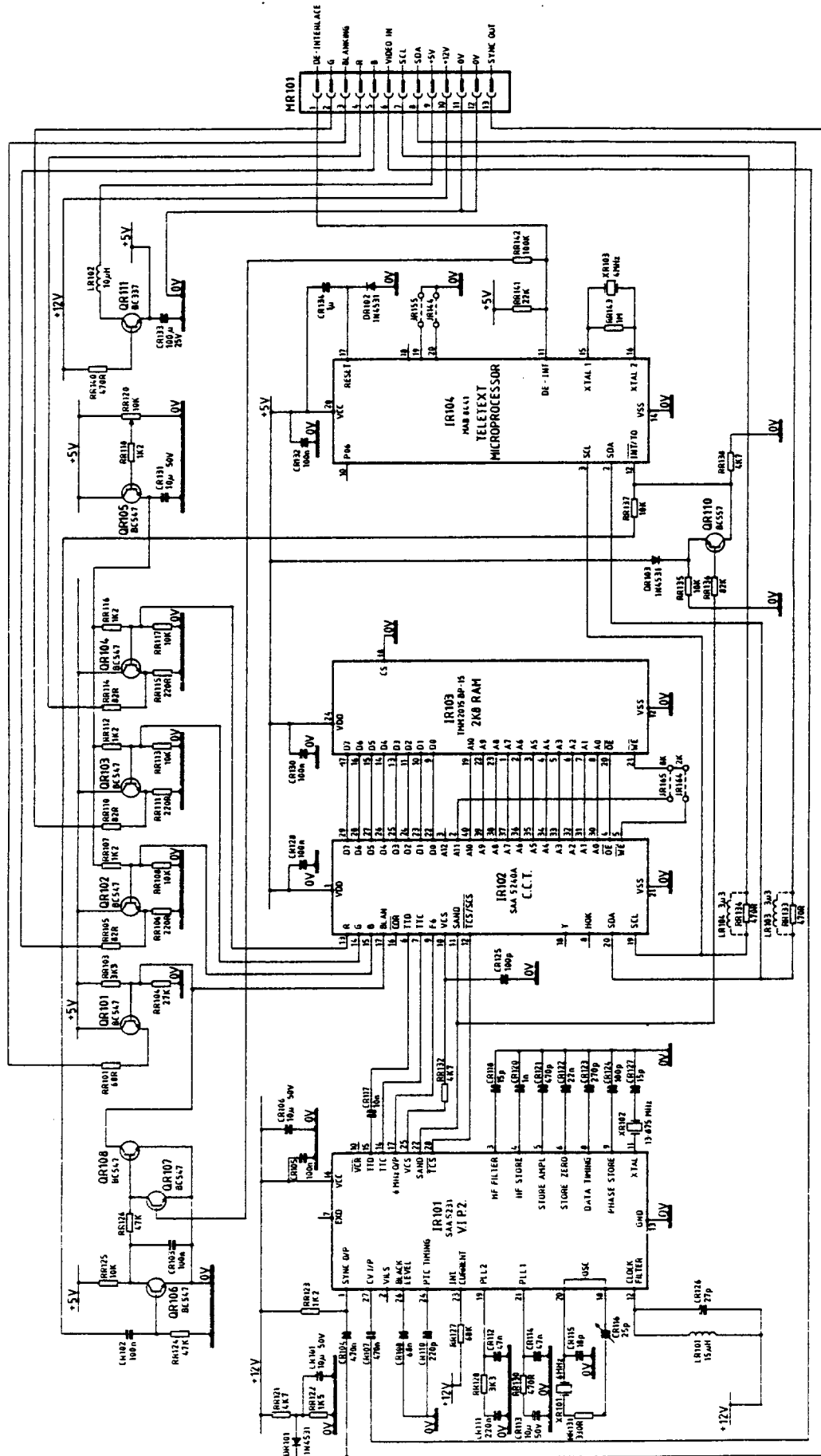

Fig. 3.8 Teletext Decoder T17/T17G (CCT) Board - Circuit Diagram.



The SAND output (Fig 3.10) on pin 11 of CCT is a three-level signal containing the phase lock (PL) and colour burst blanking (CBB) components for use in VIP2. The PL part of SAND is turned off under noisy signal conditions to allow the VIP2 phase-locked oscillator to free run.

The R.G.B. outputs (pins 13,14,15 respectively) are buffered by emitter followers and leave the Teletext Decoder board via MR101 pins 4,2,5, respectively. The amplitude of these signals is controlled by potentiometer RR120.

The BLAN output (pin 17) is active high and causes blanking of the TV picture completely for pure text or partially in the areas covered by inserted text boxes. BLAN is current buffered by QR01 before being taken to pin 3 of connector MR101.

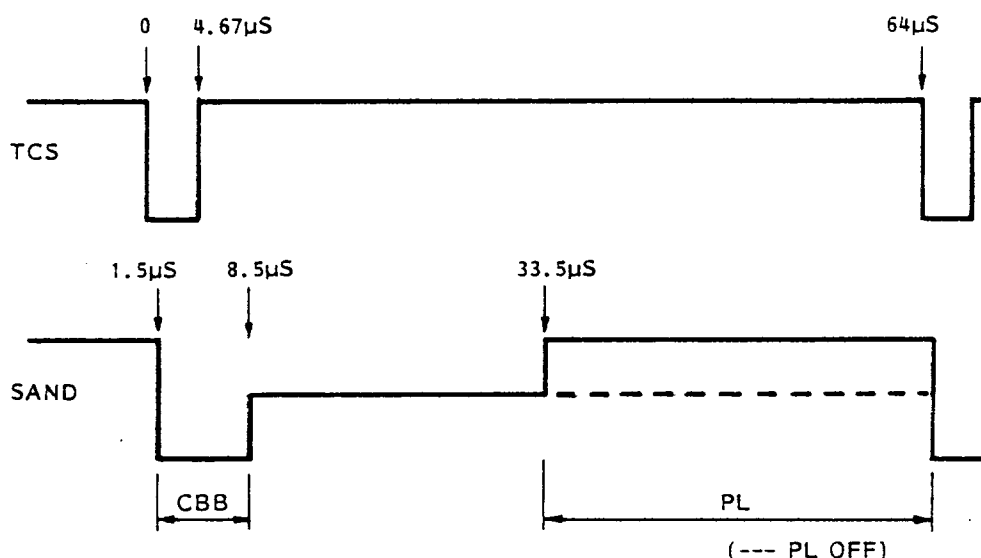

Fig 3.10 - Timing Waveforms.

c) Teletext Microprocessor (IR104)

The Teletext Microprocessor handles all communications with the Tuning Microprocessor, and the 'Firmware' within it controls the systems features. Commands are issued to CCT via the IIC bus. Pin 2 (SDA) and pin 3 (SCL) on IR104 are connected to CCT pins 20 and 19 respectively.

The Teletext Microprocessor monitors SAND via a comparator circuit (around QR110) and is interrupted at pin 12 by the phase lock (PL) component. During noisy signal conditions, PL is removed and Pin 12 no longer receives interrupts. The Teletext Microprocessor informs the system of the poor signal conditions in order to mute the audio output.

On power-up and from standby the Teletext Microprocessor is reset via CR134.

### 3.5 AV and RGB Interface Boards

The following circuit descriptions should be read in conjunction with the circuit diagrams in Fig. 3.11 and Fig 3.12.

The AV and RGB interface board are plug-in items added to the main chassis to equip the receiver to accept externally generated Composite Video (CV), RGB and audio signals. The addition and removal of relevant links plus some minor physical changes are also required. The AV board incorporates a 21-pin Euroconnector (MI50), accessible through the back cover, through which the CV, RGB and switching inputs are routed. MI50 also provides output paths for signals which correspond to what is seen and heard on the receiver.

#### 3.5.1 General.

There are two types of AV/RGB interface board, one on receivers for the UK, and the other on receivers for non-UK areas, the difference being in the way the AV mode and the RGB mode is selected.

##### (i) UK Version (System I)

AV mode is selected by depression of the AV button on the remote control hand unit.

RGB mode is selected by firstly depressing the AV button, followed by depression of the RGB button.

Depression of the AV button a second time re-selects TV mode from both AV and RGB modes.

##### (ii) Non-UK Versions (System B/G)

AV mode is selected either by pressing the AV button, as described in (i) above, or by the continuous application of 12V d.c. to pin 8 of MI50. Such a voltage is automatically generated and supplied by some VCR's and other ancillary equipment when switched on. Switching off removes the voltage and puts the receiver back into TV mode.

RGB sources can only be used if the ancillary device, when switched on, generates a 12V d.c. level (for AV switching) and a d.c. level  $>1V$  to  $<3V$  for application to pin 16 of MI50 for RGB switching. The result is selection of AV mode from which RGB mode is then accessed. Switching off the device removes the voltage levels and the receiver reverts to TV mode. The RGB button on the remote control hand unit is inoperative.

#### 3.5.2 Control Circuits (UK version)

Selection of AV and RGB modes is accomplished by toggle lines to pins 3 and pin 9 of MI52 respectively. Both signals originate at the CITAC chip (I001) on the main chassis and are +12V active high.

Selection of AV from the hand unit provides a 12V d.c. level on pin 3 of MI52. This switches II51 from internal CV to external CV and feeds this back to the main chassis via pin 2 of MI53. Additionally, II50 is switched from internal audio to external audio for feeding to the main chassis via pin 11 of MI52.

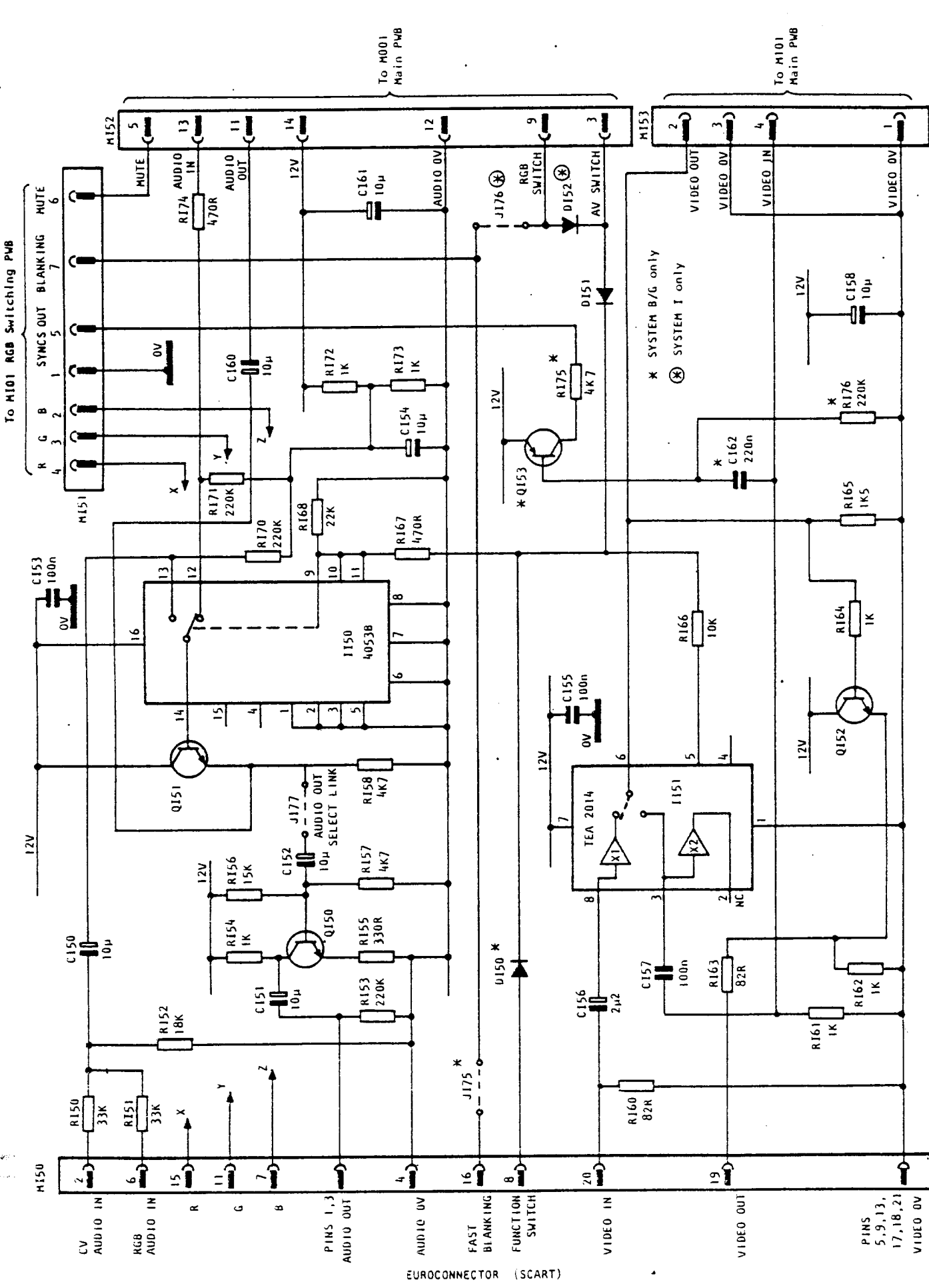

Fig 3.11 AV Interface Board - Circuit Diagram

### 3.7 Spatial Sound / Playback Stereo / German Broadcast Stereo.

There are two stereo sound options available, i.e. Spatial Sound (pseudo-stereo) for UK System I receivers, and Broadcast Stereo/Spatial Sound for German System receivers. Both involve the provision of a 21-pin Euroconnector (Scart) socket which permits the input of externally sourced AV and RGB signals, as well as providing similar outputs for processing by external equipment.

Both sound options can be supplied with either a 5 watts music power per channel amplifier to drive 8 ohm load internal speakers, or a 15 watts music power per channel amplifier to drive 7.5 watts, 8 ohms load internal speakers or 15 watts, 4 ohms load (minimum) external speakers.

A headphone socket (6.5mm dia) is also provided on German System receivers.

#### 3.7.1 Spatial Sound (UK System I).

The block diagram in Fig. 3.14 shows the interconnection of the p.c.b.'s in a receiver equipped for Spatial Sound reproduction.

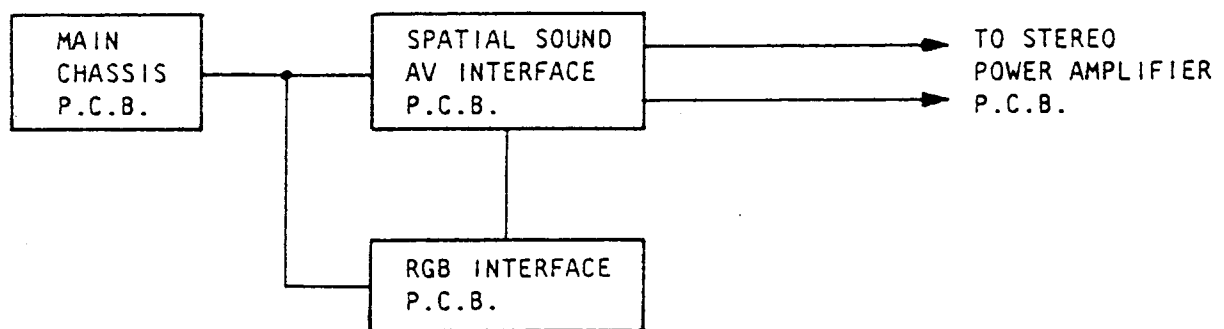

Fig. 3.14 Spatial Sound Block Diagram.

The Circuit diagram of the Spatial Sound AV Interface Board is shown in Fig. 3.15. The RGB Interface Board circuit diagram is shown in Fig 3.12.

#### a) TV Mode

During normal TV operation mono sound enters the Spatial Sound AV Interface Board via connector MI52, pin 13. After amplification, at the collector of QI51, identical signals are fed to pins 2 and 5 (left and right channels respectively) of II50 from which they emerge at pins 15 and 4 respectively. The signals are routed two ways, directly to the Stereo Power Amplifier Board via connector MI54, pins 10 and 12 for processing within the receiver, and also via buffer stages to pins 3 and 1 of MI50 for feeding to external equipment.

b) **AV Mode** (playback stereo)

Selection of the AV mode is achieved by pressing the remote control AV button to produce, via the main chassis, a +12V potential at MI52, pin 3. This switches II51 from internal CV to external CV and II50 from internal audio to external audio. In this mode a true playback stereo output from external equipment can be fed in via MI50, pins 2 and 6, and input requires identical inputs to pins 2 and 6 of MI50 to give identical mono outputs at pins 1 and 3. The signals then follow the two audio paths described in paragraph (a) above.

c) **RGB Mode**

Refer to Section 3 paragraph 3.5.1. for details of RGB operation.

3.7.2 Broadcast Stereo/Spatial Sound.

The block diagram in Fig. 3.16 shows the interconnection of the p.c.b's in a receiver equipped for broadcast stereo sound reception.

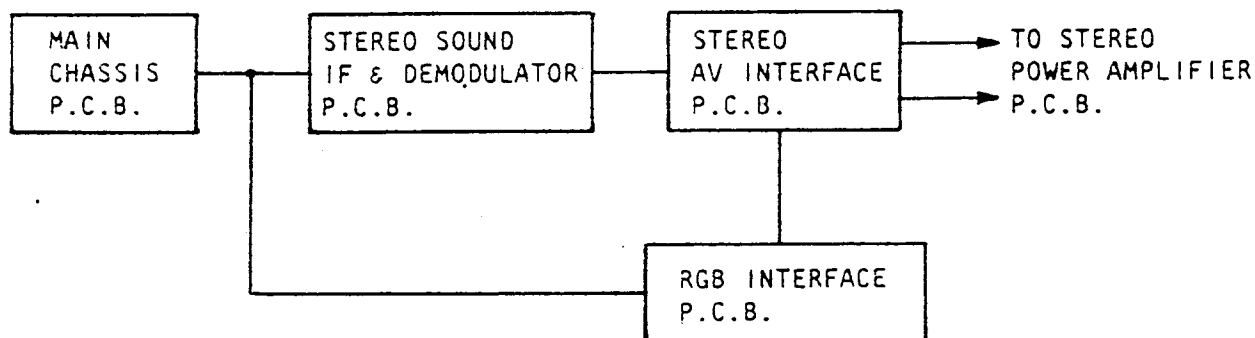

Fig 3.16 Broadcast Stereo Block Diagram.

The circuit diagram of the Stereo IF and Demodulator Board is shown in Fig. 3.17. The circuit diagram of the stereo AV Interface Board is shown in Fig. 3.18. Refer to Fig 3.12 for the RGB Interface Board circuit diagram.

a) **TV Mode**

i) Stereo IF and Demodulator Board.

There are a number of alternative audio signal possibilities available with German System transmissions, i.e. stereo sound, dual language sound, or mono sound. The stereo IF and Demodulator Board identifies and processes these signals to provide the necessary switching voltages indications.

The IF output from the main chassis is routed to II601 (TDA 2556) for FM demodulation. The outputs from this chip can be observed on pins 15 (link JI63) and 10 (JI652). For stereo transmissions the right channel is on pin 10, and a sum of the left and right channels on pin 15. For dual language transmissions the main language is on pin 15 and the secondary language on pin 10. Pin 10 also contains a 54.7 KHz AM modulated pilot signal, the modulation being a tone to identify either a stereo or a dual language transmission.

The 54.7 KHz pilot signal is routed via CI624 to pin 2 of II602 (TDA 3803) which is tuned to the signal frequency by LI604 and CI625. After AM demodulation the pilot tone emerges from pin 28 of II602. The pilot tone present is identified by one of the two tunable RC filters, 117.5 Hz for a stereo transmission, 274.1 Hz for a dual language transmission. The stereo RC filter is adjustable by means of preset potentiometer RI623, and the dual language RC filter by means of preset potentiometer RI620. The pilot tone is fed to II602, pin 5 if stereo, or to pin 6 if dual language.

For a stereo transmission a d.c. identification level appears at both pins 14 and 15 of II602. These are routed, via the flying lead from MI601, to the receiver front panel to illuminate the tri-colour LED amber. For a dual language transmission a d.c. identification level appears at either pin 14 or pin 15, according to the language selected, to illuminate the tri-colour LED either red (language 2) or green (language 1).

Mono/stereo switching and dual language switching voltages are routed from the main chassis via connectors MI52 and MI55 on the Stereo AV Interface Board to connector MI602 Pins 1 and 5 respectively on the Stereo Sound IF and Demodulator Board. As appropriate, stereo is selected when pin 1 is high, or the second language when pin 5 is high.

The output levels and the separation of the two audio channels is set by preset potentiometers RI607 and RI608. The output is a nominal 1.2V p-p on pins 2,3 and 4 of connector MI602. However, for adequate separation one output may be slightly lower.

Sound muting is routed to the Stereo Sound IF and Demodulator Board from the RGB Switching Board via processor IR01 and link JO50 on the mains chassis.

ii) German Stereo AV Interface Board.

1) Stereo Transmissions

During a stereo transmission the two channel outputs from the stereo IF and Demodulator Board are fed via MI55 pins 2 (left) and 3 and 4 (right), to pins 2, 5, 12 respectively on II50. The outputs on pins 15, 4, 14, are routed two ways, directly to MI54 pins 10 and 12 for feeding to the Stereo Power Amplifier Board, and also via buffer stages to pins 3 and 1 on MI50 for feeding to an external amplifier.

## 2) Dual language transmission.

During a dual language transmission the two language outputs from the stereo IF and Demodulator Board are fed via MI55 to II50. The language selected appears on pins 2 and 4 of MI55, whilst the alternative appears on pin 3. The switching arrangement of II50 routes the selected language to MI54 pins 10 and 12 i.e. identical signals to each one for amplification in the Stereo Power Amplifier Board. This signal is also routed via a buffer stage to pin 3. The alternative language is routed via a buffer stage to MI50 pin 1. This arrangement ensures that both languages are accessible via the Euroconnector at all times when in dual language mode.

### b) AV Mode (playback stereo)

Selection of the AV mode is achieved either by pressing the AV button on the remote control hand unit, or by the application of a continuous voltage (Function Switching) delivered from the external equipment being used. Pressing the AV button produces, via the main chassis, a +12V potential at MI52, pin 3. Via diode DI51, this switches II51 from internal CV to external CV, and II50 from internal audio to external audio. Alternatively, if the external equipment produces a switching voltage automatically when switched on, this can be applied to pin 8 of MI50 (Euroconnector). Via diode DI50, this performs the same internal to external switching functions described earlier.

Either way, externally produced playback stereo audio signals can be input via MI50 pins 2 and 6 for feeding directly to the Stereo Power Amplifier Board through MI54, pins 12 and 10. These same signals are also routed back to the Euroconnector, MI50 pins 1 and 3, for feeding an external amplifier.

### c) RGB Mode

Refer to Section 3, paragraph 3.5.1 for details of RGB operation.

## 3.7.3 STEREO POWER AMPLIFIER BOARDS.

There are two alternative Stereo Power Amplifier Boards, both of which can be used to provide the sound output stage of UK system I (Spatial Sound) and German System (Broadcast Stereo) receivers. One provides 5 watts music power per channel to drive internal speakers. (Fig. 3.19.) and the other provides 7.5 watts music power per channel to drive internal speakers or 15 watts per channel to drive external speakers (Fig. 3.20.). When used on German System receivers both boards incorporate a headphone jack socket.

### a) Connections

The Stereo Power Amplifier Board is connected to the appropriate AV Interface Board via a 12-way cable to connector MA01 which carries the audio and control lines as well as the voltage supplies. A 2-way cable connects to MA02 and carries the Spatial select signal from processor IR01 on the main chassis front panel and a return voltage for providing a visual indication that the Spatial mode has been selected.

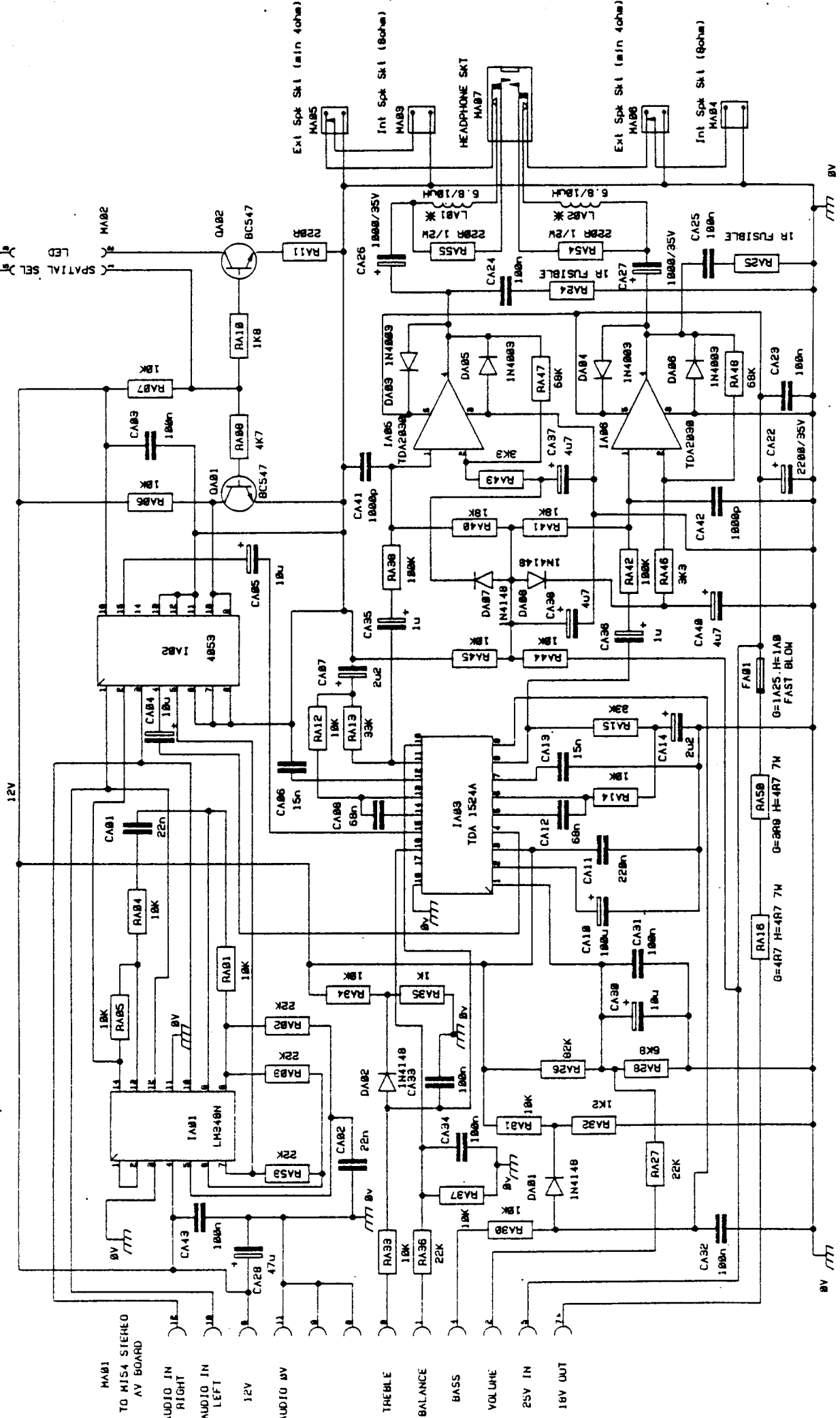

Fig 3.20 Stereo Power Amplifier Board (15 Watts).



i) 5 Watt Amplifier.

The 5 watt board is fitted with a single two-channel power amplifying device, IA04, which requires a +23V rail. The audio outputs are connected to internal speakers via connectors MA03 and MA04. On German system receivers a headphone jack socket is fitted when this is used the speakers are disconnected.

ii) 15 Watt Amplifier.

The 15 watt board is fitted with two single channel power amplifying devices which are driven from a +25V rail. These devices can deliver 7.5 watts per channel to drive the internal 8 ohm speakers via connectors MA03 and MA04, and up to 15 watts to drive external speakers of not less than 4 ohms impedance via connector MA05 and MA06. The plugging in of external speakers automatically disconnects the internal speakers.

An additional socket is provided for headphones on German System receivers. This provides between 100mW and 150mW, sufficient to drive low impedance headphones. Plugging in headphones automatically disconnects whatever speakers are being used.

- (b) Connect a voltmeter between chassis ground and the junction of L805 and C425.
  
- (c)
  - (i) 170 Series  
Adjust the Set HT control (R808) to give a reading of 115V d.c. (109.5V d.c. on 19"/21" (50/55cm) FST receivers).
  - (ii) 180 Series  
Adjust the Set HT control (R808) to give a reading of 150V +/- 0.5V.

## SECTION 4 - ADJUSTMENTS

### 4.1 Test Equipment

4.1.1 Mains isolation transformer of at least 200W rating.

4.1.2 TV Test Signal Generator with:

- a) Colour bar modulation
- b) Sound carrier at 5.5 MHz (B & G) or 6MHz (I) spacing, modulated with 1 kHz sine wave at 50 kHz deviation.
- c) Output available on a wide range of channels including:  
VHF: Band I and Band III ) as appropriate to  
Cable TV channel ) receiver under test  
U.H.F. )
- d) Output level selectable in range 50uV to 100mV.
- e) Vestigial sideband modulation (if possible).

4.1.3 Oscilloscope and 10:1 probe of known accuracy at TV IF frequency.

4.1.4 RF signal generator capable of generating the appropriate sound IF signal, 5.5 MHz (B&G) or 6MHz (I), accurate to +/- 5kHz and modulated with 1 kHz at 50 kHz deviation.

4.1.5 Unmodulated signal source, 38.9 MHz (B&G) or 39.5MHz (I) accurate to +/- 10 kHz with an output of 100mV.

4.1.6 Frequency counter.

4.1.7 Multimeter to measure 0 to 12V ( a d.c. coupled oscilloscope may be used if available).

4.1.8 Audio load resistors - 8 ohms, 5W or 16 ohms, 2.5W as necessary.

4.1.9 Audio filter to reject 1kHz by 40dB or more with optional output meter (preferable true r.m.s.)

4.1.10 Plastic or Ceramic tipped trimming tools.

### 4.2 Set HT

(a) (i) 170 Series

Reduce the beam current to zero by setting the A1 control and the customer contrast and brightness controls to minimum.

(ii) 180 Series

Adjust the brightness and contrast to 50% (5.5V on pins 25 and 26 of I001) with colour bar pattern displayed.

b) **Power Supplies**

The audio power output stage voltage supplies originate at the Switched Mode Power Supply transformer (T801) on the main chassis. The type of transformer fitted depends upon the type of Stereo Power Amplifier Board fitted. The 5 watts version receives +23V at pin 5 of MA01 and the 15 watts version receives +25V. In both cases high wattage resistors drop this to +18V for feeding back to the main chassis via MA01 pin 7 and the AV Interface Board.

c) **Spatial Sound**

Spatial sound is a user selectable feature on all models covered by this publication and is effective for broadcast and play back signals. When selected whilst listening to a mono signal a pseudo stereo effect is produced. When selected whilst listening to a stereo signal the result is a "widening" of the stereo effect.

The Spatial Sound effect is created by using three operational amplifiers in IA01 and components RA01 - RA05, RA53, and CA01-CA02 on the power amplifier board. These are configured to give phase reversed, frequency dependent cross-talk between the two audio channels across the mid-frequencies.

The left and right audio channel signals enter the Stereo Power Amplifier Board via pins 10 and 12 of connector MA01. They are routed to IA02 which switches between normal and spatial sound using a switching voltage which originates from micro-processor IR01 pin 8 on the main chassis and enters the Stereo Power Amplifier Board at connector MA02, pin 1. The +5V logic level is converted to +12V to switch IA02. A return voltage is routed via MA02, pin 2 to illuminate the decimal point of the right hand 7-segment front panel display to provide a visual indication that the Spatial Mode has been selected.

The functions of this section can be monitored by feeding the same tone (approx. 3KHz) into MA01, pins 10 and 12, and monitoring the speaker outputs. The outputs are in phase with each other in the mono mode. When the Spatial mode is selected the outputs become 90° out of phase with each other.

d) **Audio Controls.**

The volume, balance, treble and bass functions are performed by IA03 in response to d.c. control signals from the CITAC chip (I001) on the main chassis. Entering the board via connector MA01 the voltages are converted from a 0 to 12V range to a suitable control range for IA03. The tone controls have a range of approximately +6dB/-2dB.

e) **Audio Power Output Stages**

Before entering the power output stage on both Stereo Power Amplifier Boards the audio signals are attenuated and routed via a low pass filter to remove any unwanted high frequency noise.

TO HQ81 MAIN BOARD

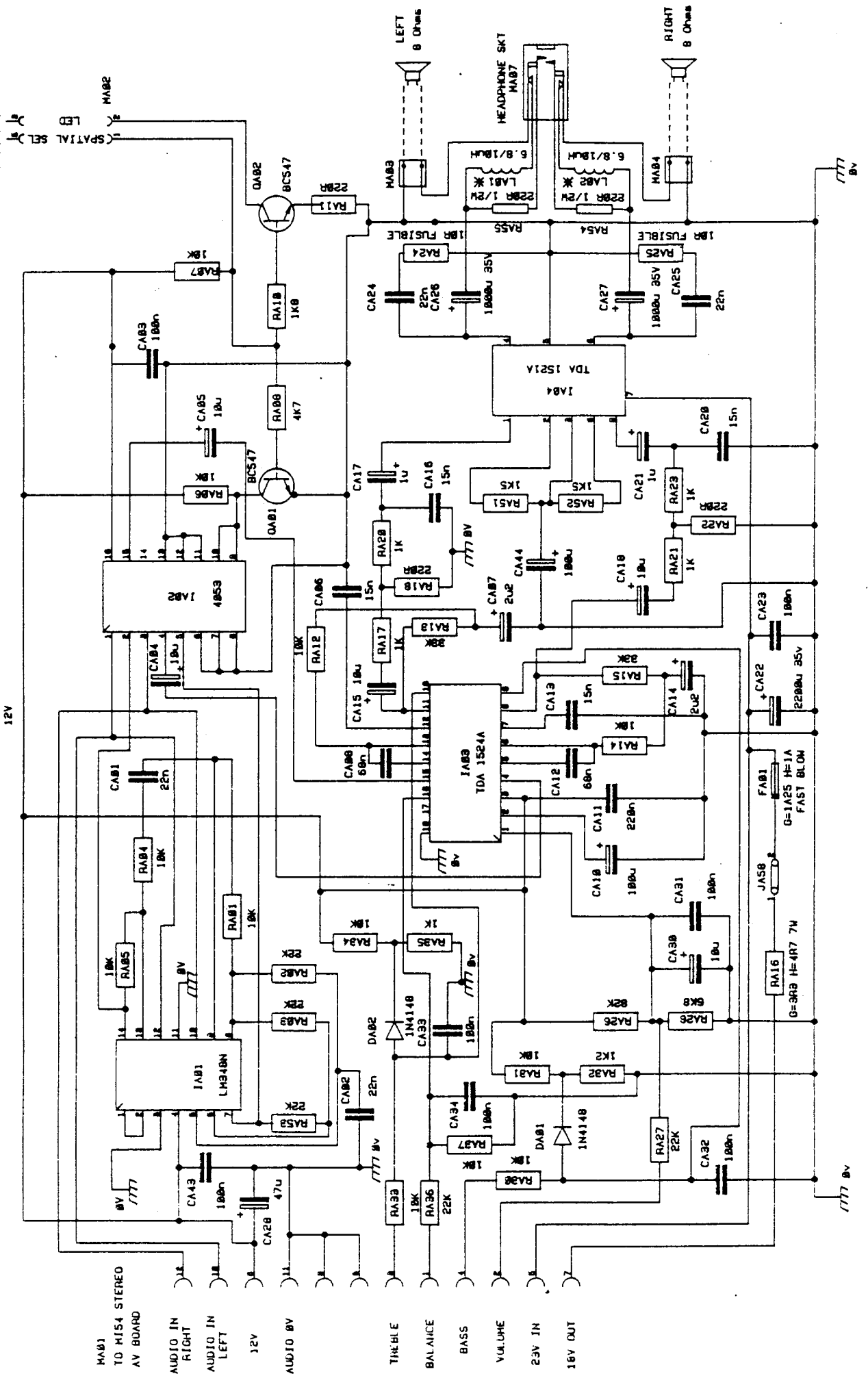
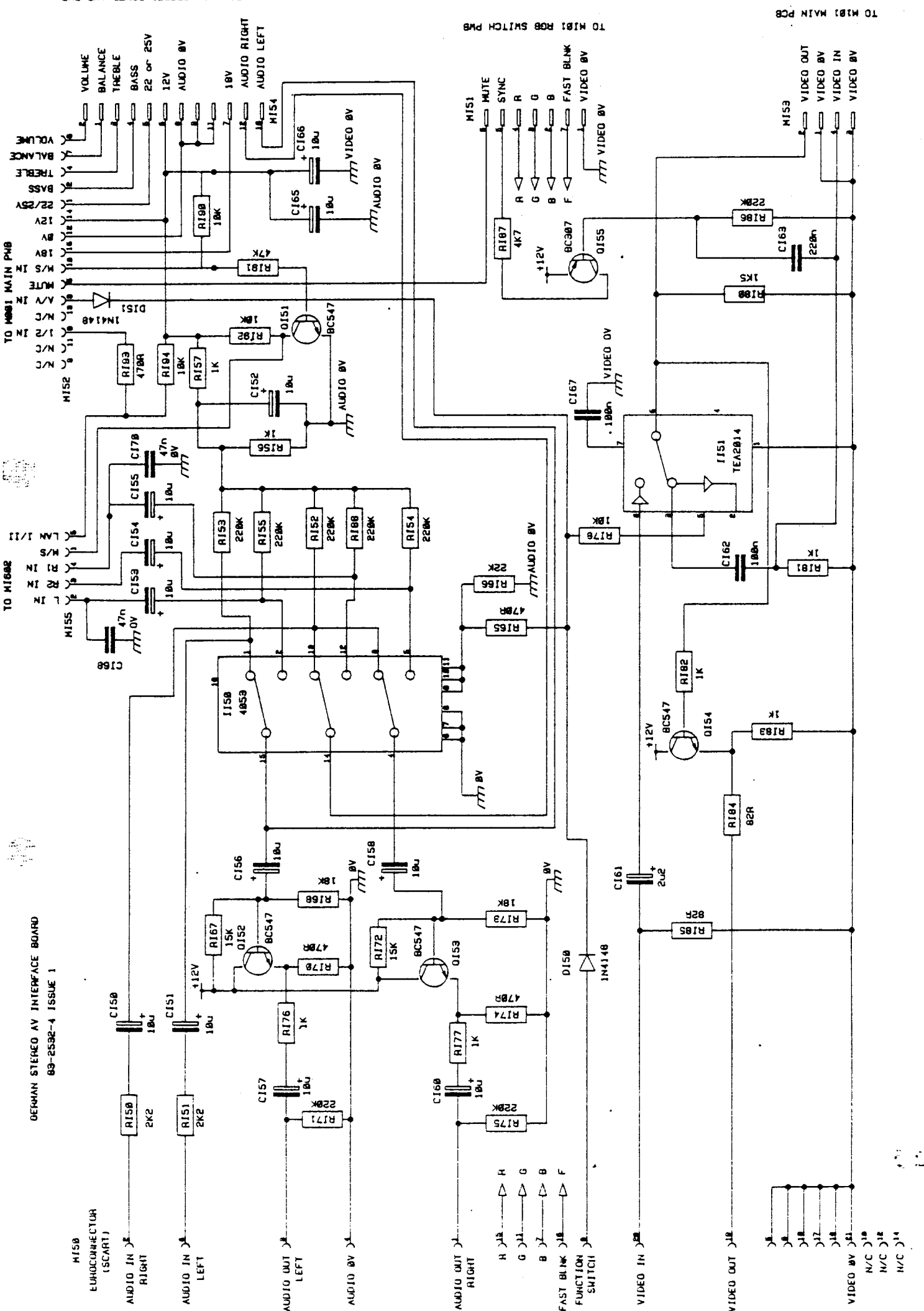

Fig 3.10 Stereo Power Amplifier Board (5 Watts).

GERMAN STEREO AV INTERFACE BOARD  
83-2532-4 ISSUE 1



TO M101 MAIN PCB

TO M101 R08 SWITCH PCB

TO M101 MAIN PCB

TO M101 MAIN PCB

TO M101 MAIN PCB

TO M101 MAIN PCB

TO M101 MAIN PCB

TO M101 MAIN PCB

TO M101 MAIN PCB

TO M101 MAIN PCB

TO M101 MAIN PCB

TO M101 MAIN PCB

TO M101 MAIN PCB

TO M101 MAIN PCB

TO M101 MAIN PCB

TO M101 MAIN PCB

TO M101 MAIN PCB

TO M101 MAIN PCB

TO M101 MAIN PCB

TO M101 MAIN PCB

TO M101 MAIN PCB

TO M101 MAIN PCB

TO M101 MAIN PCB

TO M101 MAIN PCB

TO M101 MAIN PCB

TO M101 MAIN PCB

TO M101 MAIN PCB

TO M101 MAIN PCB

TO M101 MAIN PCB

TO M101 MAIN PCB

TO M101 MAIN PCB

TO M101 MAIN PCB

TO M101 MAIN PCB

TO M101 MAIN PCB

TO M101 MAIN PCB

TO M101 MAIN PCB

TO M101 MAIN PCB

TO M101 MAIN PCB

TO M101 MAIN PCB

TO M101 MAIN PCB

TO M101 MAIN PCB

TO M101 MAIN PCB

TO M101 MAIN PCB

TO M101 MAIN PCB

TO M101 MAIN PCB

TO M101 MAIN PCB

TO M101 MAIN PCB

TO M101 MAIN PCB

TO M101 MAIN PCB

TO M101 MAIN PCB

TO M101 MAIN PCB

TO M101 MAIN PCB

TO M101 MAIN PCB

TO M101 MAIN PCB

TO M101 MAIN PCB

TO M101 MAIN PCB

TO M101 MAIN PCB

TO M101 MAIN PCB

TO M101 MAIN PCB

TO M101 MAIN PCB

TO M101 MAIN PCB

TO M101 MAIN PCB

TO M101 MAIN PCB

TO M101 MAIN PCB

TO M101 MAIN PCB

TO M101 MAIN PCB

TO M101 MAIN PCB

TO M101 MAIN PCB

TO M101 MAIN PCB

TO M101 MAIN PCB

TO M101 MAIN PCB

TO M101 MAIN PCB

TO M101 MAIN PCB

TO M101 MAIN PCB

TO M101 MAIN PCB

TO M101 MAIN PCB

TO M101 MAIN PCB

TO M101 MAIN PCB

TO M101 MAIN PCB

TO M101 MAIN PCB

TO M101 MAIN PCB

TO M101 MAIN PCB

TO M101 MAIN PCB

TO M101 MAIN PCB

TO M101 MAIN PCB

TO M101 MAIN PCB

TO M101 MAIN PCB

TO M101 MAIN PCB

TO M101 MAIN PCB

TO M101 MAIN PCB

TO M101 MAIN PCB

TO M101 MAIN PCB

TO M101 MAIN PCB

TO M101 MAIN PCB

TO M101 MAIN PCB

TO M101 MAIN PCB

MONO/STEREO IN  
CHAN 1  
CHAN 2  
LANG 1  
LANG 2  
MI602 TO MISS AV BOARD

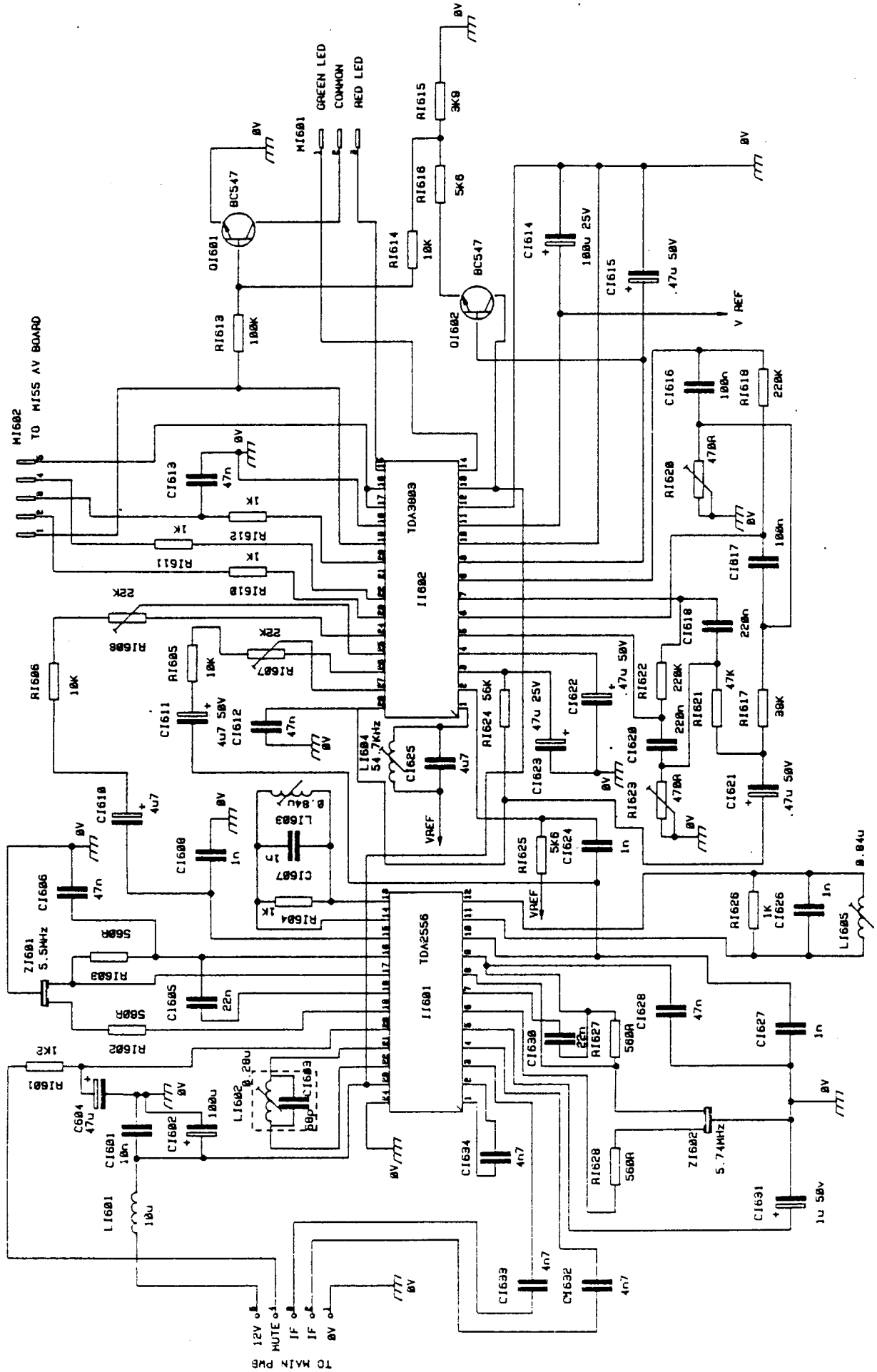

Fig. 3.17 Stereo IF and Demodulator Board.

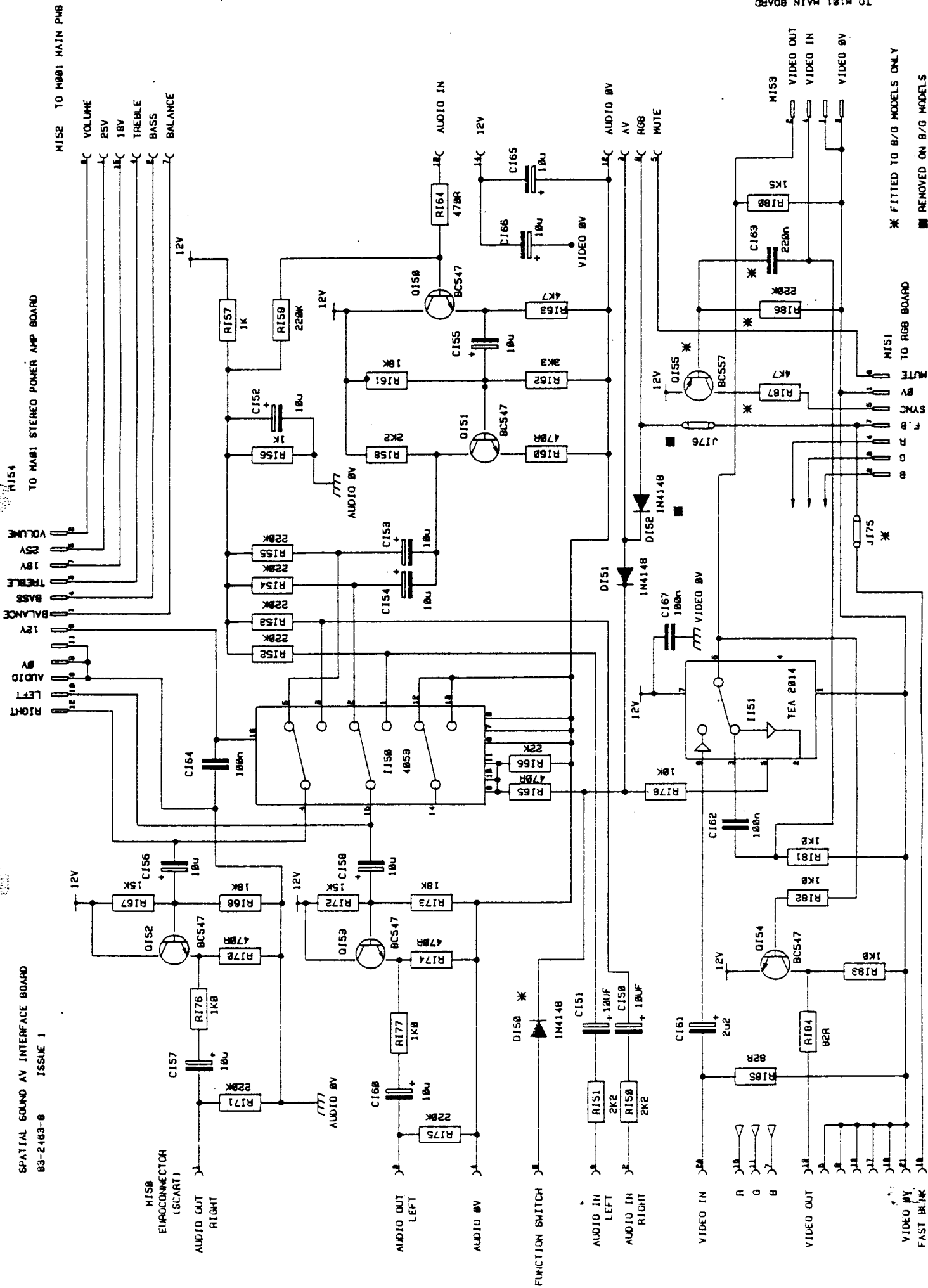

Fig. 3.15 Spatial Sound AV Interface Board.

TO M151 MAIN BOARD

\* FITTED TO B/G MODELS ONLY  
■ REMOVED ON B/G MODELS

\* TO RGB BOARD  
MUTE  
SYNC  
1  
2  
3  
4  
5  
6  
7  
8  
9  
10  
11  
12  
13  
14  
15  
16  
17  
18  
19  
20  
21  
22  
23  
24  
25  
26  
27  
28  
29  
30  
31  
32  
33  
34  
35  
36  
37  
38  
39  
40  
41  
42  
43  
44  
45  
46  
47  
48  
49  
50  
51  
52  
53  
54  
55  
56  
57  
58  
59  
60  
61  
62  
63  
64  
65  
66  
67  
68  
69  
70  
71  
72  
73  
74  
75  
76  
77  
78  
79  
80  
81  
82  
83  
84  
85  
86  
87  
88  
89  
90  
91  
92  
93  
94  
95  
96  
97  
98  
99  
100



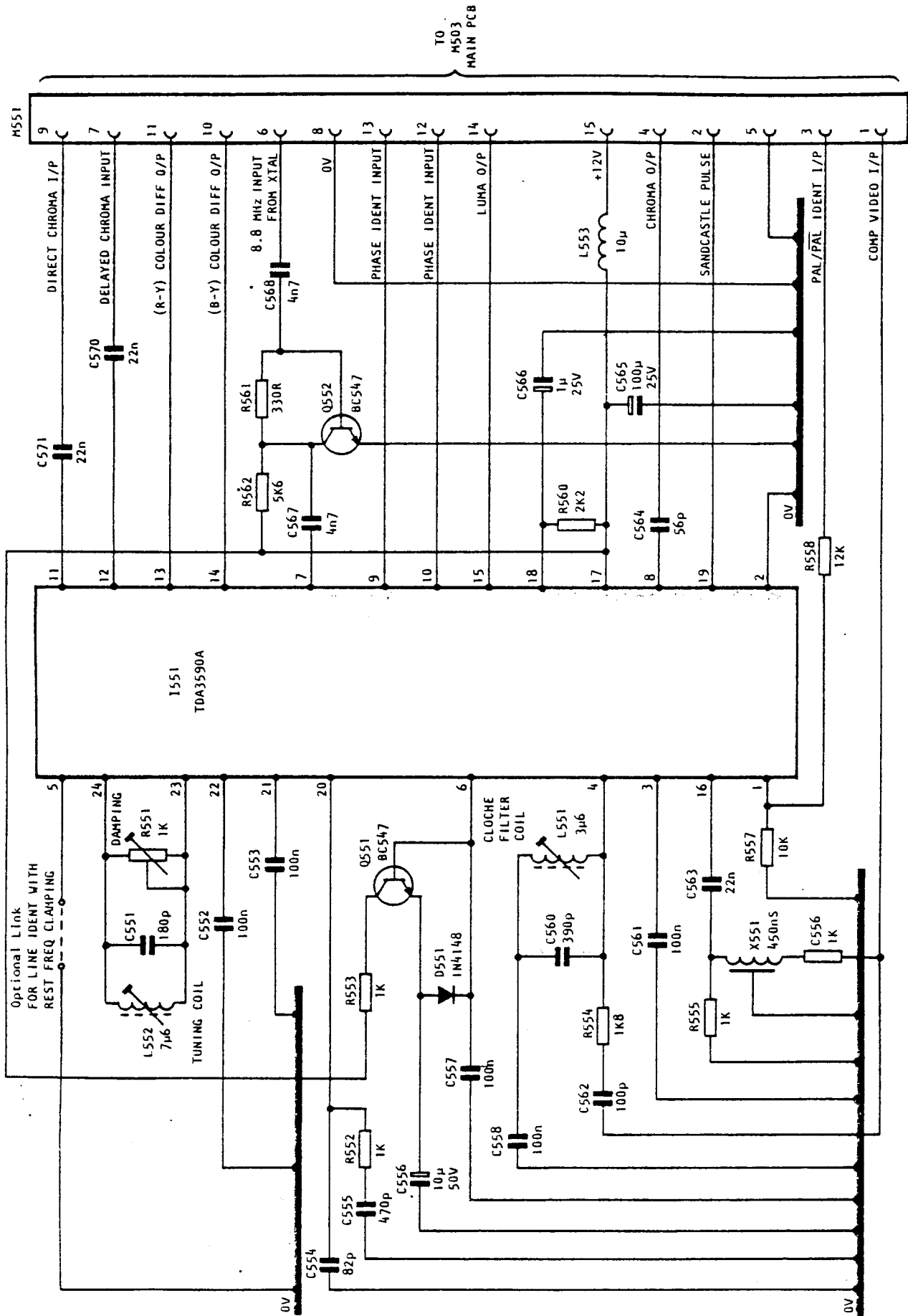

Fig. 3.13 SECAM Transcoder Board - Circuit Diagram.

Selection of RGB (whilst already in AV mode) provides a 12V d.c. level on pin 9 of MI52. This switches II01 to external RGB by applying a 'low' to its switching pins (pins 10,12,15, II01) and a high (approx 1.5V) to the PAL decoder switch. Note that a high blanking line from the teletext board switches II01 to internal RGB to allow teletext information to be displayed.

### 3.5.3 Control Circuits (non-UK versions).

Selection of AV mode is either from the hand unit or from the application of an externally generated 12V switching voltage on pin 8 of MI50. Both selection methods initiate identical switching procedures as described in 3.5.2.

Selection of RGB is achieved by application of the 12V AV switching level on pin 8 and RGB switching voltage >1V to <3V to pin 16 of MI50. This puts the RGB switch under the control of the blank line from the teletext board so that RGB is selected whilst TXT is not called up. Calling up TXT enables teletext information to be displayed.

### 3.5.4 Composite Video Input

The CV input on pin 20 of MI50 is amplified by II51 to approx. 2V p-p and fed to the main chassis via pin 2 of MI53.

### 3.5.5 RGB Input

The RGB signal inputs to pins 7, 11, 15 of MI50 are all attenuated by 6dB across the potential dividers across MI01 and then amplified by II01 to approx 0.7V p-p before being routed to the main chassis via pins 8, 2, 6 of MI02.

### 3.5.6 Sync Input in RGB Mode

The RGB sync input is applied to the CV input on pin 20 of MI50. This is amplified by 6dB in II51 and routed to the main chassis for sync input.

### 3.5.7 Audio Input

In both AV and RGB modes the audio input is fed via pins 2 and 6 of MI50. It is fed via II50 and buffer amplifier QI51 to the main chassis.

### 3.5.8 Phase Locked Loop (non-UK versions only)

The video from the IF stage is fed into the AV board on pin 4 of MI53. This is buffered by QI53 and fed to the PLL (II02). The output from II02 is buffered and inverted by QI03 before being fed back to the main chassis as a MUTE signal via pin 6 of MI01.

### 3.5.9 Composite Video and Audio Outputs.

The CV output on pin 19 and the audio outputs on pins 1 and 3 of MI50 are replicas of the signals fed to the internal circuits in TV and AV modes. In RGB mode only the sync is output on pin 19. CV to the main chassis is buffered by QI52 to provide a 1V p-p signal at pin 19 into 75 ohms. Audio to the main chassis is buffered by QI51 and amplified by QI50 to provide 0.5V r.m.s on pins 1 and 3.

The de-interlace output on IR104 pin 11 is used to set the sync processor into de-interlace mode. This leaves the Teletext Decoder board via MR101, pin 1. This output also serves to indicate that the system is in 'blanked screen teletext mode', and inhibits 'mix mode' and 'status boxes' during poor signal conditions so as to 'prevent' the teletext screen from rolling.

Combinations of two link options are available to allow the command set to be displayed in different languages, as shown in Table 3.4.

Table 3.4

<u>Language</u>	<u>Link JR154</u>	<u>Link JR155</u>
English	removed	removed (TT17)
German	removed	inserted (TT17G)
Swedish	inserted	removed

d) 2K8 Random Access Memory (RAM) IR103

The 2K8 RAM stores the character data for two selected teletext pages, one of which is displayed. The RAM is addressed, written to and read by the CCT IC, in which the character data is transformed into a dot matrix pattern.

TTC appears on VIP2, pin 14 and is used to clock teletext data into CCT (IR102).

The composite sync part of the video signal is output as VCS on VIP2, pin 25, and its line component is compared with the sandcastle input (SAND) (Fig 3.8) on pin 22. This locks the 6MHz resonator (XR101) to provide a phase-locked 6MHz system clock (F6) on pin 17 (Accurate setting-up of the 6MHz clock is described in Section 4, paragraph 2).

When the system is in 'text' mode the composite sync. output TCS (Fig 3.8) from CCT pin 12 is passed to VIP2, pin 28 and is output from VIP2 to pin 1. The d.c. level is then restored to provide the sync signal to the receiver timebases via MR101, pin 13.

a) Video Input Processor (VIP2) (IR101)

This IC processes the analogue video signal to produce all the clock references and the digital teletext data.

Video enters the decoder board via MR101 pin 6. This is coupled via capacitor CR107 to pin 27 of VIP2. It is then processed by an adaptive data slicer which sets the threshold level for slicing at half the data amplitude regardless of the amplitude of the incoming signal. This gives some compensation for distortion, e.g. co-channel interference, thereby improving system performance under adverse conditions. Serial TTD (Fig. 3.9) leaves VIP2 via pin 15.

A data clock signal TTC (Fig 3.9) is generated from the sliced data by using the external 13.875 MHz crystal, XR102.

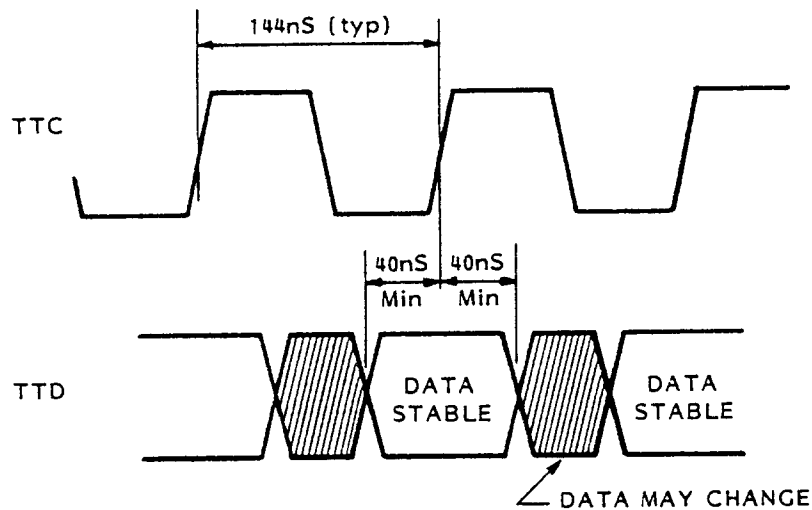

Fig 3.9 Data Waveforms

b) Computer Controlled Teletext (CCT) (IR102)

The CCT IC processes the serial digital teletext data from VIP2 into a parallel error-detected form which can be written into memory. CCT also uses clock information from VIP2 to generate synchronising information used by the teletext system.

TTC on IR102, pin 7 is used to clock teletext data (TTD on IR102, pin 6) into CCT. The rising edges of the clock are nominally at the centre of the valid data period. The data is processed to produce memory address and data information.

The main 6MHz system clock, supplied from VIP2, is internally buffered to produce a 50% duty cycle, used in the timing for the display. Field synchronisation of CCT is effected through the VCS input signal on IR102 pin 10. This signal, provided by VIP2, is 'slewed' by a filter to reduce the cut-off level of the signal quality detectors. The VCS signal is assessed by a digital signal quality detector within CCT.

A TCS output on pin 12 of CCT is used to provide drive for the display timebases when in full teletext mode (i.e. blanked screen teletext mode using 312/313 non-interlaced picture scan).

### 3.4 Teletext Decoder TT17/TT17G (CCT) Board.

The Teletext Decoder p.w.b. is a plug-in item which, depending upon the model of receiver, may be supplied already fitted or as a retrofit option at a later date. To retrofit the board proceed as follows:

- 1 Plug the teletext decoder p.w.b. into socket M501.
- 2 Cut link J566 which is located to one side of M501.
- 3 Fit the plastic clip (supplied) between the decoder and the L.O.P. stage screening plate to secure the p.w.b.
- 4 Teletext Contrast Setting:
  - a) Select TEXT followed by MIX
  - b) Set RR120 on the text p.w.b, so that the text white level is equal to the TV picture white level.

The Teletext Decoder circuit diagram is shown in Fig 3.8 and should be used in conjunction with the main circuit diagram when reading this description. To assist in correlating these paragraphs with the decoder circuit diagram a number of abbreviations have been used, with meanings as follows:

BLAN - blanking	SDA - serial data
CBB - colour burst blanking	TCS - teletext composite sync.
CCT - computer controlled teletext	TTC - teletext clock
IC - integrated circuit	TTD - teletext data.
IIC - inter - IC	VCO - voltage controlled oscillator
PL - phase lock	VCS - video composite sync.
SCL - serial clock	VIP2 - video input processor.

#### 3.4.1 Control Interface

The Teletext System Microprocessor (IR104) receives commands sent from the Tuning Microprocessor via the two-wire IIC bus (refer to paragraph 3.3.1 for further details). The Teletext Microprocessor decodes the commands, and communicates with the 'Computer Controlled Teletext' IC (IR102) which implements the commands.

#### 3.4.2 Teletext Decoder

The teletext decoder extracts teletext data during the vertical blanking period of the video signal. It processes and decodes the data so that it can be displayed in the form of user selectable pages of text. The teletext system is controlled totally by the Teletext Microprocessor which receives and issues commands.

The Teletext Decoder is always powered when the receiver is switched on. Power enters the decoder p.w.b. via connector MR101, +12V on pin 10, +5V on pin 9, 0V on pins 11 and 12. When the receiver is in 'standby' mode the +12V input is removed, and this shuts off transistor QR111 to disconnect the +5V supply from the rest of the decoder board.

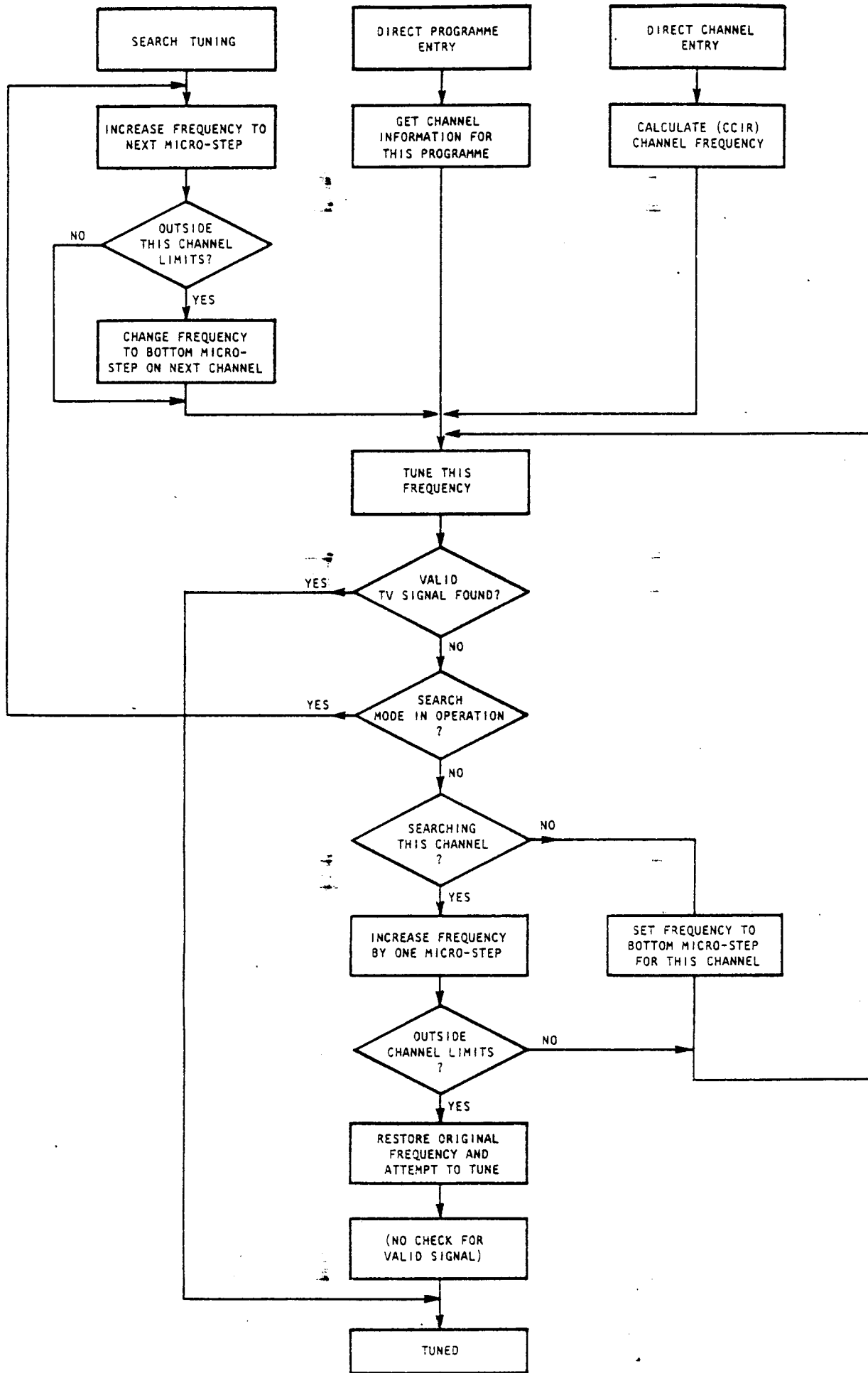

Fig 3.5 Tuning System Flowchart.

### SECTION 3 - CIRCUIT DESCRIPTIONS

No attempt has been made<sup>3</sup> to describe those parts of the circuit which will already be familiar to the experienced service engineer. Reference to the main circuit diagram (loose in the cover pocket of this publication), and the main chassis and tube base p.w.b. layouts (see Figs 4.2, 4.3 and 4.4 at the end of Section 4) will provide most of the information to enable efficient servicing to be carried out. Our Service Division is always available for consultation during normal working hours in the event of difficulties.

Circuit descriptions are provided in the following paragraphs as per the index below:-

- 3.1 RC70 Remote Control Hand Unit  
(Infra-red Transmitter)
- 3.2 Infra Red Receiver
- 3.3 Tuning and Control System - including fault finding charts (Figs 3.6 & 3.7).
- 3.4 Teletext Decoder TT17/TT17G (CCT) Board.
- 3.5 AV and RGB Interface Boards.
- 3.6 SECAM Transcoder Board.
- 3.7 Spatial sound / playback stereo / German Broadcast Stereo.

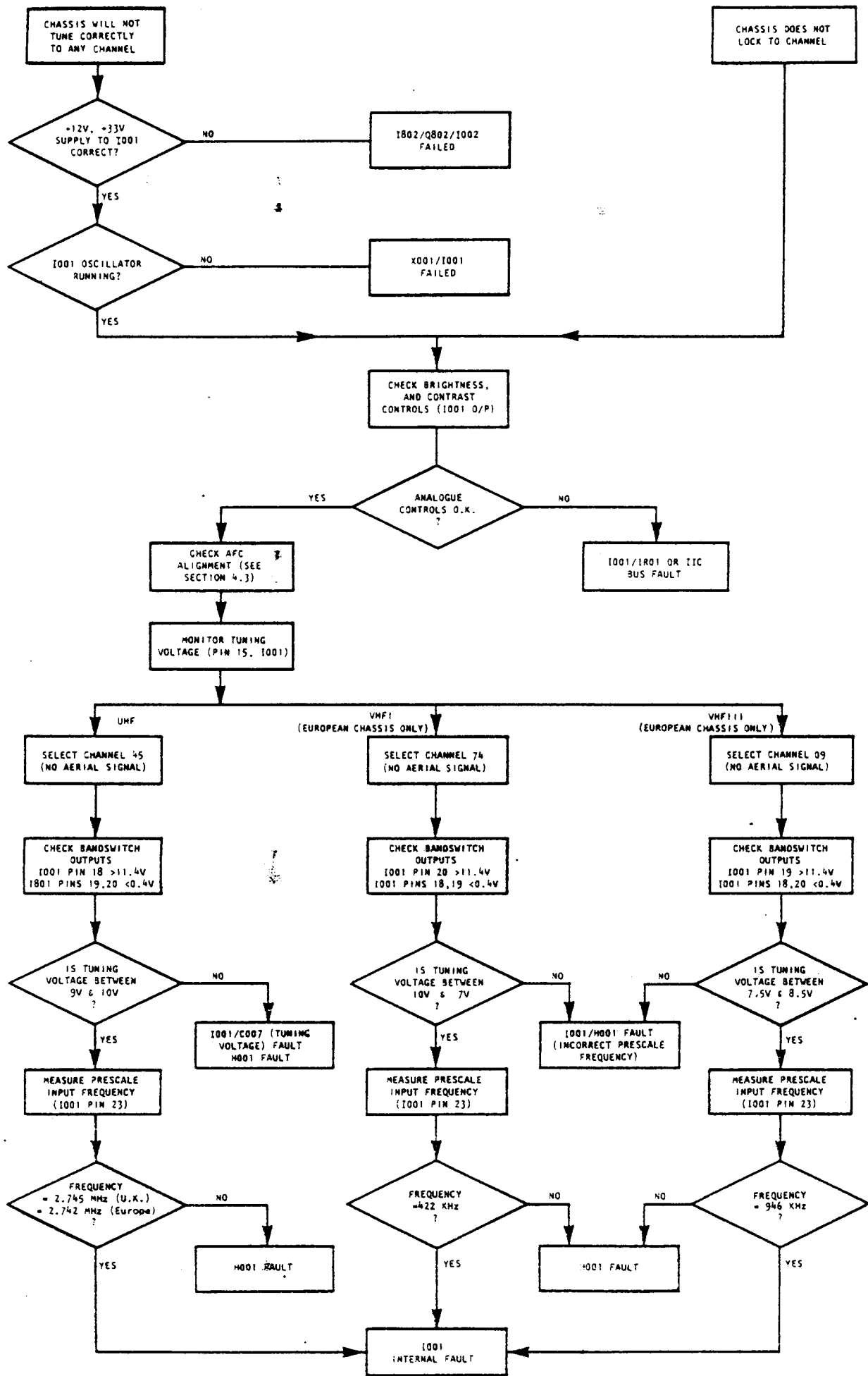

Fig 3.6 Fault Finding Chart - Tuning System



### 2.3 Main Chassis - Front Panel Removal/Fitting.

The front panel is secured to the main chassis by two rivet-like screws with 2mm. Allen - key socket heads. Removal of the screws and unsoldering the electrical connections allows the panel to be lifted clear. To fit a front panel first secure the assembly using the two screws and then solder the electrical connections.

### 3.3.5 Analogue Controls

The seven analogue function commands on the remote control (volume, brightness, contrast, colour, bass, treble, balance) control seven variable-level outputs on the Computer Interface for Tuning and Control (CITAC) device - I001.

The output from pins 1-4 & 25-28 of I001 varies between a minimum of 1.0V and a maximum of 10.0V in 64 discrete steps. When the appropriate command is received and decoded by IR01 the internal copy of the analogue control level is incremented or decremented by one step and the new value is transmitted to I001 via the IIC bus. On receiving this information I001 converts the IIC data to an analogue voltage at the pin output. Table 3.2 shows analogue output pin number and control function.

When the Teletext board is fitted to the chassis, IR01 also transmits information to the Text Microcomputer (IR104) in order that the bar graph graphics may be displayed on-screen when an analogue control button is operated.

Table 3.2

Function	I001 pin	Comments
Volume	1	
Balance	2	(not used on all models)
Colour	4	
Contrast	25	
Brightness	26	
Treble	27	(not used on all models)
Bass	28	(not used on all models)

A 'fast switch-on' circuit is included which ensures that the closure of the momentary contact is detected even when the chassis has been standing with the mains disconnected for some time (e.g. overnight). This operates by maintaining a charge on capacitor CR01 whilst the chassis is running. When the mains is disconnected from the chassis, CR01 is prevented from discharging by diode DR01, and therefore retains its charge for a considerable time. When the mains is re-applied to the chassis the Switched-Mode-Power-Supply (SMPS) may take a number of mains cycles to start. During this period the momentary contact of SC80-1 discharges CR01 into CR02 via RR02. When the 5V supply rail is established and the Tuning Microcomputer begins operation sufficient charge remains on CR02 to forward-bias transistor QR01 and pull the standby input of IR01 (the Tuning Microcomputer) 'low'. After IR01 has detected the low level on pin 1, it internally grounds pin 1 to keep the 12V supply regulator I802 enabled after CR02 has discharged via the base-emitter junction of QR01. Standby mode is now controlled by IR01 and can be entered or exited via the appropriate hand unit commands.

Once the chassis enters normal operating mode (whether from Standby or power-up) the Tuning Microcomputer (IR01) attempts to tune to the last programme selected using the programme number which is stored in Non-Volatile memory (IR02). Tuning then continues in the normal manner (refer to para. 3.3.8).

Table 3.1

Function	Command Code Bits (see fig 3.1)	Function	Command Code Bits (see fig 3.1)
	F E D C B A		F E D C B A
TV/AV	0 0 0 0 1 0	Digit 1	0 1 1 0 1 0
Mute	0 0 0 0 1 1	Digit 2	0 1 1 0 1 1
Standby	0 0 0 1 0 0	Digit 3	0 1 1 1 0 0
Fine -	0 0 0 1 0 1	Digit 4	0 1 1 1 0 1
Fine +	0 0 0 1 1 0	Digit 5	0 1 1 1 1 0
Volume -	0 0 0 1 1 1	Digit 6	0 1 1 1 1 1
Volume +	0 0 1 0 0 0	Digit 7	1 0 0 0 0 0
Brightness -	0 0 1 0 0 1	Digit 8	1 0 0 0 0 1
Brightness +	0 0 1 0 1 0	Digit 9	1 0 0 0 1 0
Contrast -	0 0 1 0 1 1	Digit 0	1 0 0 0 1 1
Contrast +	0 0 1 1 0 0	Channel Select	1 0 0 1 0 0
Colour -	0 0 1 1 0 1	2 Digit('nn') entry	1 0 0 1 0 1
Colour +	0 0 1 1 1 0	Picture	1 0 0 1 1 0
Mix	0 0 1 1 1 1	Text	1 0 0 1 1 1
Analogue bar/cancel	0 1 0 0 0 0	Rotate	1 0 1 0 0 0
Sub-Code	0 1 0 0 0 1	Bass - / List	1 0 1 0 0 1
Hold	0 1 0 0 1 0	Bass + / Browse	1 0 1 0 1 0
Size	0 1 0 0 1 1	Status	1 0 1 0 1 1
Treble + / Reset	0 1 0 1 0 0	Balance left	1 0 1 1 0 0
Treble - / Reveal	0 1 0 1 0 1	Balance right	1 0 1 1 0 1
Norm/Initial Page	0 1 0 1 1 0	Stereo/Mono	1 0 1 1 1 1
Pseudo stereo/store	0 1 0 1 1 1	RGB	1 1 0 0 0 0
Programme -	0 1 1 0 0 0	Language (I/II)	1 1 0 0 0 1
Programme +	0 1 1 0 0 1		

### 3.3 Tuning and Control System

The tuning and control system circuit is part of the main chassis. Refer to the main circuit diagram when reading this description.

#### 3.3.1 Serial Interface Bus and Micro-Computer Control

This chassis incorporates a serial interface bus which conforms to the Philips IIC (Inter-Integrated Circuit) bus. This interface consists of two lines - the serial data line (SDA) and serial clock line (SCL). These interconnect the various devices which utilise the feature and allow the micro-computers for tuning and text (when fitted) to control other programmable devices with a minimum of interconnection. The format of the transmission protocol is beyond the scope of this text. However, it may be necessary to check for signals on the bus during fault diagnosis, and to this end a generalised diagram of the waveforms is shown in Fig 3.4.

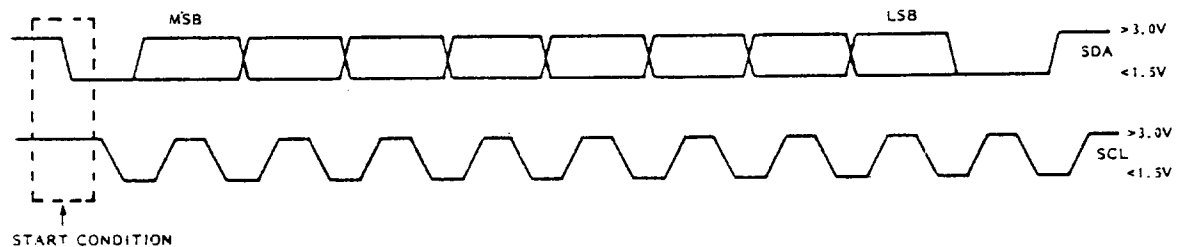

Fig. 3.4 Serial (IIC) Bus Format

All tuning and picture control functions are initiated by the Tuning Microcomputer (IRO1). This device is a single-chip microcomputer which controls the television in response to the controls on the local or remote keypads, and also in response to signals from other parts of the chassis. To perform this control function the microcomputer receives inputs directly on the pins of IRO1, or indirectly from other devices via the IIC bus. This necessarily implies that from initiation of a command/signal there will be little measurable effect other than at the output affected (if any). Other devices controlled by the Tuning Microcomputer via the IIC bus are the Computer Interface for Tuning and Control (CITAC), the Non-Volatile-Random-Access Memory (NVRAM), and the Teletext Microcomputer (where fitted) which itself controls the computer Controlled Teletext (CCT) decoder via the IIC bus.

With AFC enabled the tuner frequency is corrected by the AFC circuit (via pin 5, I101 and pin 12, I001) whilst the tuner frequency remains within the AFC hold range, and CITAC operates almost independently of the Tuning Microcomputer (I001). If the tuner frequency should move outside the AFC hold-range however, CITAC can no longer track the signal and the Tuning Microcomputer (I001) must regain control of the tuning system. In practice, during normal operation, the tuner frequency is continuously checked against the programmed frequency and if a mismatch is found the programmed frequency is incremented/ decremented in 50kHz steps to track the signal. This ensures that the AFC hold range is maintained symmetrical about the tuner frequency whilst tracking a drifting signal.

The remote control and local keypads give a variety of methods for tuning a particular frequency. However, the basic tuning method is always the same, although the means by which the channel number is calculated may change. Refer to Fig. 3.5 for a full Tuning System Flowchart.

#### In-channel Search:

Once the required vision-carrier frequency is known the relevant band is calculated by I001 from the channel number and the band is switched via the IIC bus and I001 pins 18,19 and 20. The carrier frequency is then transmitted to I002 (from the Tuning Microcomputer) as data on the IIC bus and I001 tunes to this frequency. When the tuner frequency matches the programmed frequency of the Tuning Microcomputer, I001 enables the AFC and checks for an AFC lock condition. If AFC lock occurs then a further check is made for coincidence detection in the synchronisation circuit (Via I401 pin 13 and I001 pin 10). This enables the microcomputer to detect that a valid television signal has been tuned.

If AFC lock fails or coincidence is not achieved by I501 the Microcomputer initiates an 'in-channel search' for a valid TV signal. The channel is split into six discrete sections or 'microsteps' and each microstep is searched in turn (lowest frequency first) by setting the tuner frequency to the middle of the microstep, enabling the AFC, and checking for AFC lock and coincidence of the synchronisation circuit. If a valid signal is not found the search continues in the next microstep. The process is repeated in up to six micro steps until a valid TV signal is found. The action that follows is dependent on the tuning selection mode used.

Note: An in-channel search may be forced at any time by entering again the currently selected programme number.

#### Direct Programme Selection:

In normal viewing when a programme selection is made the channel frequency associated with this programme is read, by I001, from the Non-Volatile-Memory (I002) where it has previously been stored. Once the frequency is known I001 initiates an 'in-channel search' (see previous paragraph). If a valid signal is not found within this channel then the stored frequency is re-tuned (after the microstep search) and tuning is aborted.

### 3.3.6 Muting

Muting of the audio signals is controlled by the Tuning Microcomputer via pin 1, I001 (volume control signal) and pin 27, IR01 (sound IF mute) in response to the coincidence detector output from pin 13, I401 (pin 10, I001) and the IF phase-locked-loop output from Q103 collector. In the presence of a valid TV signal, i.e. coincidence detected by I401, the volume control output (pin 1, I001) is taken to its normal operating level as set by the user. If, however, coincidence is not detected the output is forced to a level 1.0V in order to mute the audio (speaker) output. Note that this action will not mute the low-level audio output from the sound IF stage (pin 9 I601) which is used on the AV/SCART daughter-board (where fitted). This method of muting is therefore dependent on the presence of sync. pulses at the input of the sync. processor (pin 5, I401), regardless of the signal source, which could be from the vision IF stage or from the AV/SCART interface.

On B/G versions of this chassis which are fitted with the AV/SCART option, a phase-locked-loop circuit is incorporated into the interface which takes its input from the vision IF at all times. This signal is used by the Tuning Microcomputer (pin 13, IR01) to detect that a valid signal is present at the vision IF output. The audio output from the AV/SCART socket can thus still be muted in the absence of a valid-off-air signal even when in AV mode.

### 3.3.7 Pseudo-Stereo, (Spatial Sound) Mono/Stereo, Dual Language and RGB Option Switches.

The software within the Tuning Microcomputer incorporates decoding for commands associated with the optional daughter-boards which may or may not be fitted according to the particular model. These commands toggle the outputs of pins on IR01 and I001 as shown in Table 3.3

Table 3.3

Command	Pin	Comments
Pseudo-stereo	IR01, pin 8	(active 'high')
Mono/stereo	I001, pin 7	(stereo active 'high')
Language 1/2	I001, pin 9	(language 2 active 'high')
RGB Select	I001, pin 8	(active 'high' Valid in AV mode only).

### 3.3.8 Frequency Synthesis Tuning System

The tuning system is based on the CITAC device (I001) which is controlled by the Tuning Microcomputer (IR01) at all times via the IIC bus. Tuning is by frequency-locked-loop digital control with AFC. The actual tuner frequency is divided by a factor of 256 within the tuner (H001) and fed to I001 pin 23 where it is compared with the frequency required, as programmed from IR01 with AFC disabled. The tuning voltage (pin 15, I001) is corrected using the result of this comparison, forming a closed-loop control system which ensures that the tuner frequency is equal to the programmed frequency.

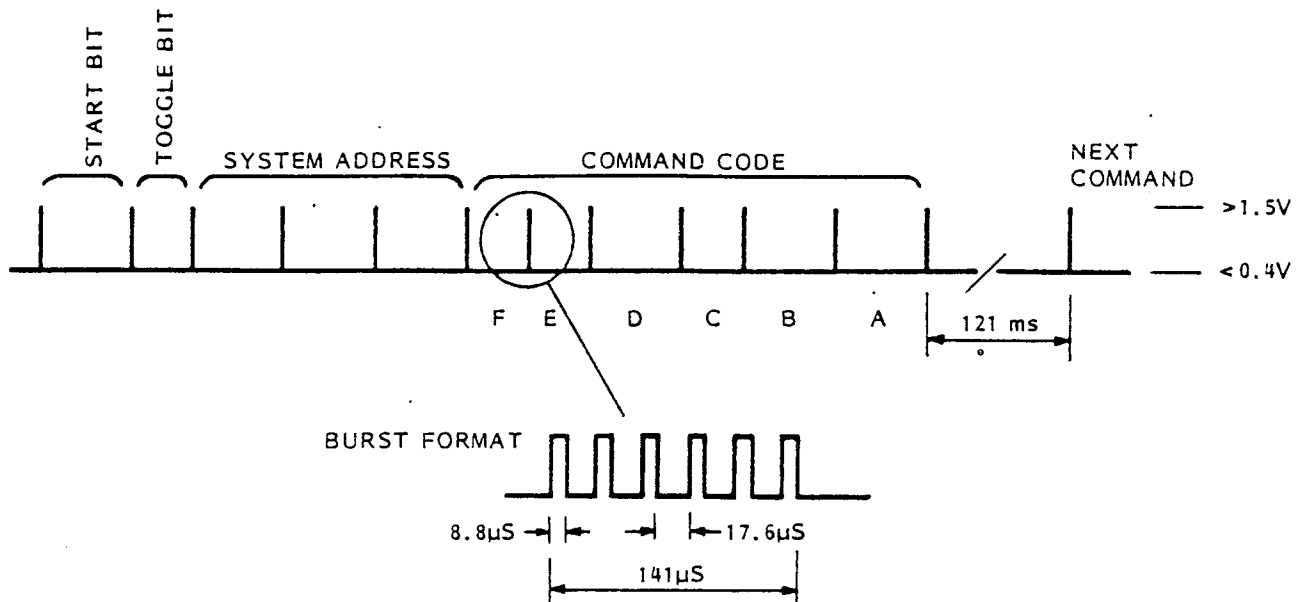

Fig. 3.2 Infra Red Transmitter (IT01, Pin 1) Output.

### 3.2 Infra Red Receiver

The Infra-Red Receiver Circuit is part of the main chassis. Refer to the main circuit diagram in the pocket of this publication when reading this description.

The coded infra-red signals are detected by an infra-red diode DS01 and fed to the pre-amplifier IS01. In addition to providing gain IS01 incorporates AGC circuitry to improve the performance in noisy environments, and a pulse-stretched output to allow the Tuning Microcomputer (IR01) to decode the signal. The output signal (pin 11, IS01) inverted with respect to the input (Pins 1,16 IS01), is normally 'high' ( 4.9V) and pulses 'low' ( 0.5V) when an infra-red pulse is received. The width of the output pulses is governed by capacitors CS07 and CS08 which ensure a minimum duration of 200uS. Fig 3.3 shows IS01 output format.

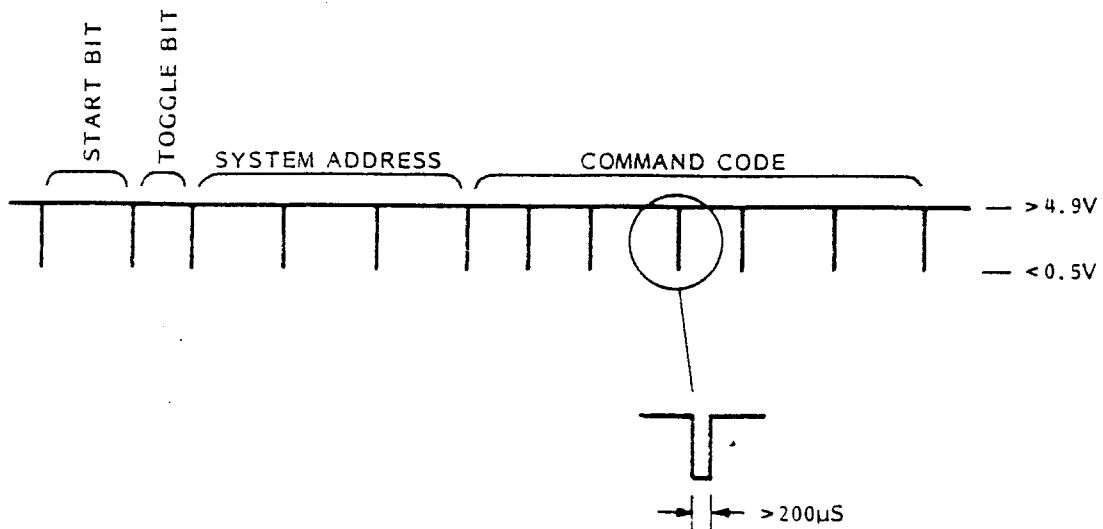

Fig 3.3 Infra Red Receiver (IS01, pin 11) Output

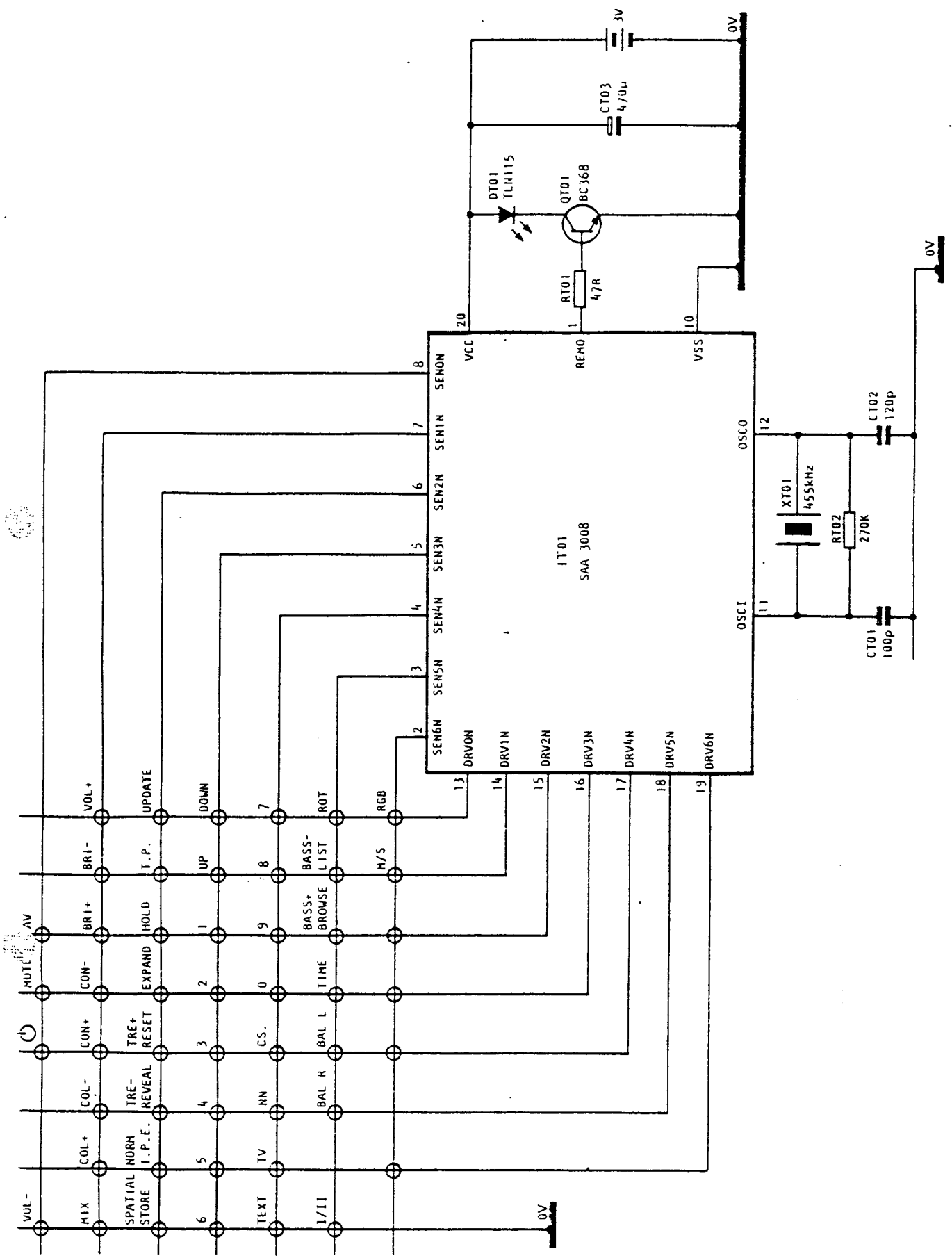

Fig. 3.1. RC70 Remote Control Hand Unit - Circuit Diagram



### 3.3.2 Link Selectable Options

Two link positions are provided on the front panel of the chassis. These select:

- i) The tuning system (link JR02) - European (System B/G) with the link fitted.  
- UK (System I) with the link not fitted

Note: this link must be set according to the tuner unit fitted.

- ii) AV mode (JR01) - valid (i.e. daughter board fitted) with the link fitted.  
- invalid with the link removed.

For UK (System I) tuning, only bands IV/V are valid, when system B/G is employed band I, III, IV and V are valid.

### 3.3.3 Mains On/Off and Standby Mode

The mains on/off switch (SC801) is fitted with a momentary contact to allow the Tuning Microcomputer to detect the operation of the switch and decide in which mode to operate the chassis when mains power is applied.

If mains voltage is applied with the on/off switch already in the 'on' position then the chassis will enter Standby mode i.e. the 12V supply is disabled which shuts down the tuning control, I.F. stage, colour decoder, and timebase circuits. If, however, the mains voltage is applied by closing the mains switch the Tuning Microcomputer will detect this and enable the 12V supply, thus placing the chassis in it's normal operating mode.

Entry to, and exit from Standby mode can be made using the Standby key on the remote-control hand-unit. Alternatively any number (digit) key, or the 'NN' key on the hand-unit will invoke normal operation from Standby mode.

### 3.3.4 Local Controls and L.E.D. Display.

The local control switches (SM01 to SM06) operate a limited range of functions (Volume Up and Down, Programme Up and Down, Tuning Search, and Tuning Memorise). These key-switches are scanned periodically by the Tuning Microcomputer (via pins 4-7\* on IR01) to check for key depressions.

The 2-digit LED display (DL01, DL02) is directly driven by the Tuning Microcomputer (IR01). Pins 18 to 24 of the Microcomputer drive the segment cathodes of both display devices and pin 25 of IR01 provides a multiplex control signal to the anode driver transistors QL01, QL02, which drive DL01 and DL02 respectively. The multiplex output is a square-wave of frequency 55Hz +/- 2Hz. The decimal point of DL01 is driven, via QL03, to provide a 'message received' indication in response to the remote control system commands.

\* Early models (i.e. with QR02 fitted).

When in 'Standby' mode, pin 6 of IR01 operates as an auxiliary input to maintain the correct mark: space ratio of the L.E.D. multiplex signal (IR01, pin 25), via the standby output (IR01, pin 1) and QR02.

## SECTION 2 GENERAL SERVICING NOTES

### 2.1 Safety And Isolation

Under no circumstances should any form of repair or maintenance be attempted by any person other than a competent technician or engineer. Most of the circuitry on the chassis is isolated from the mains by T801, C818, C819, R818 and 6mm air gaps. To maintain this safety factor, ensure that after repair, any gaps and leakage paths are not reduced by protruding wires, etc., following component replacement. Connecting wires should be routed clear of resistors which run hot, e.g. R801.

NOTE: Although the output supplies from the power supply section are isolated from the incoming mains supply, the bridge rectifier and the control and regulation circuits are not isolated. Therefore, when servicing the power supply section of the panel, the chassis should be supplied via a mains isolation transformer of at least 200W rating.

The power supply section remains charged with respect to chassis for 30-60 seconds after switching off. Care should be taken when handling the chassis to avoid touching this area during this time.

Components marked  $\triangle$  on the parts list and circuit diagram are safety approved types and should be replaced only with components supplied or approved by our Service Department. It is also recommended that components not marked with the safety symbol should be replaced by parts of the type originally fitted, and this applies particularly to those resistors which are stood off the printed circuit boards.

#### HANDLING PRECAUTIONS - Static Electrical Charges.

The receiver contains devices which may be damaged by static electrical charges during handling. When replacing, or handling these devices, care should be taken. Soldering irons should be earthed, and personnel should use wrist straps earthed via a 1M ohm resistor. If the latter is not practicable, they should discharge themselves of any static electricity by touching an earthed point.

Static sensitive devices should be packed in suitable conductive containers.

It should be stressed that, although the receiver chassis is isolated, it must be disconnected from the supply during service replacement of these devices.

### 2.2 Access

Chassis access - after removing the back cover, loosen the fixing screws from each of the two chassis support brackets. Note the warning in paragraph 2.1 to delay handling of the chassis for approximately 60 seconds after switch-off. The main chassis may then be withdrawn from the cabinet to provide access to preset adjustments, copper track side, etc.

Repeat the procedure for programmes 3 and 4 to tune to ITV1 and ITV2 (Channel 4) respectively.

b) If the official channel numbers are not known.

Select programme 1 as described in (a) above (using the local controls is more convenient in this case). Press the local button SEARCH and the receiver will continue tuning until it detects a TV channel of sufficient strength to "lock onto".

If the picture is that for BBC1, press local button MEM. If not press SEARCH again and tuning will continue until another TV channel is "locked onto". If this is BBC1, press MEM. If not repeat the SEARCH procedure until the correct channel is located. Repeat the procedure for programmes 2,3 and 4 i.e. BBC2, ITV1 and ITV2 respectively.

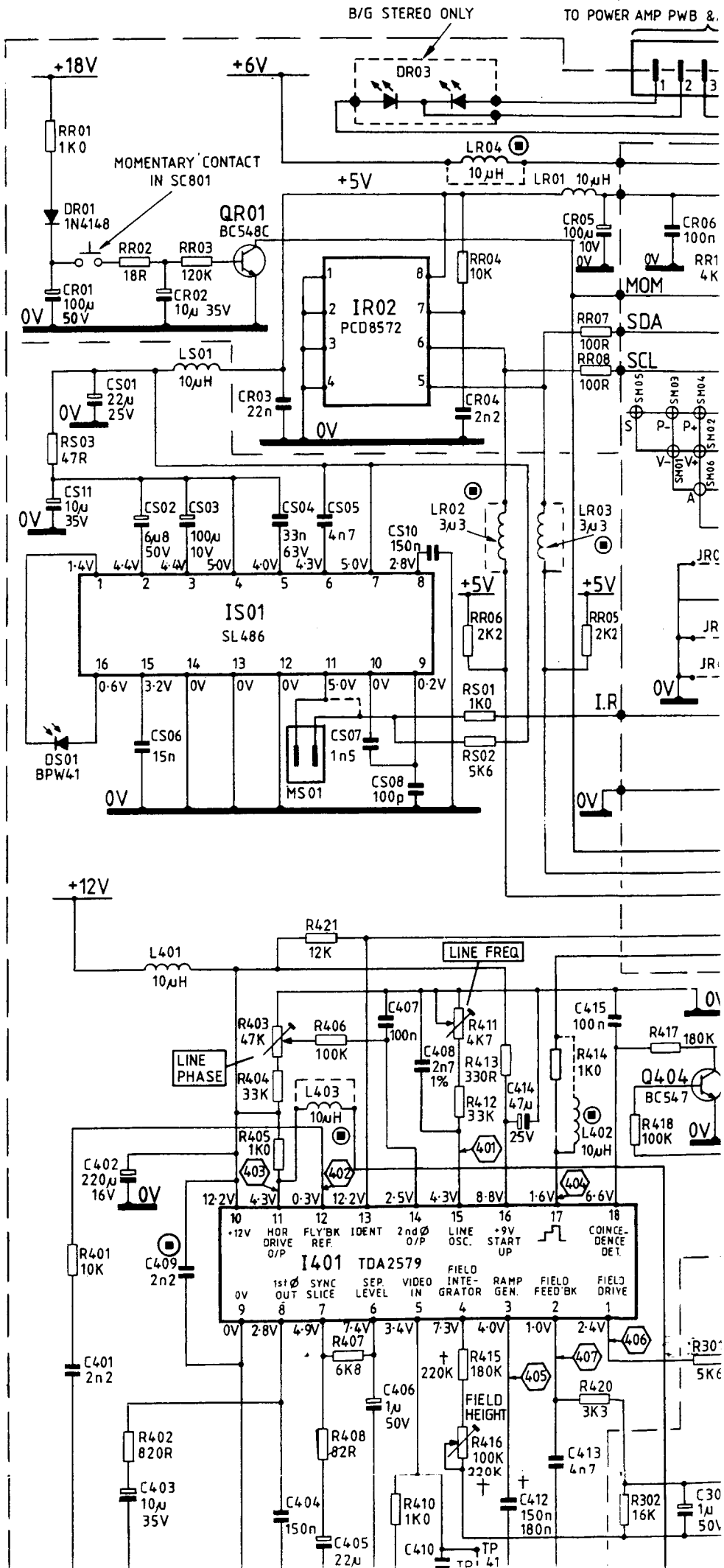
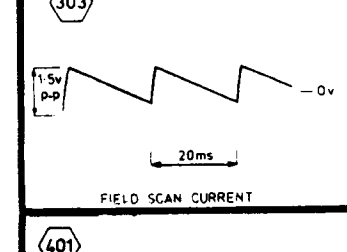
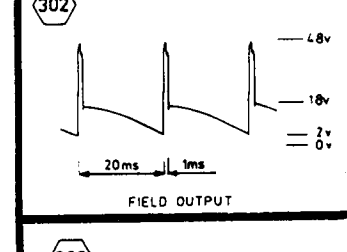
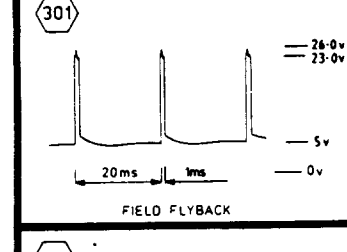
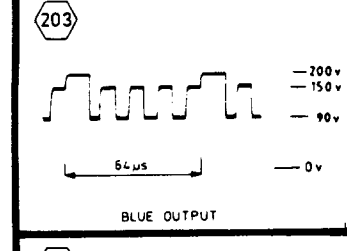
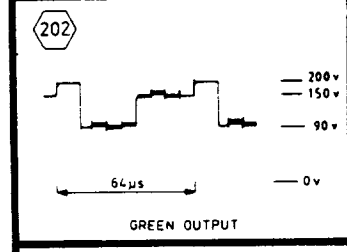
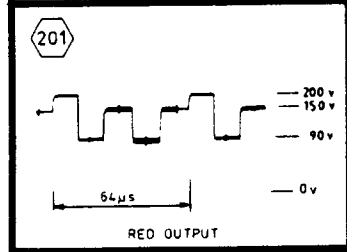
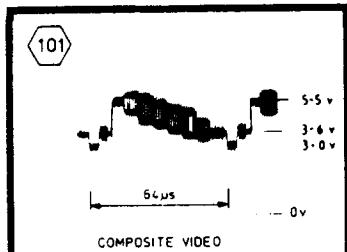

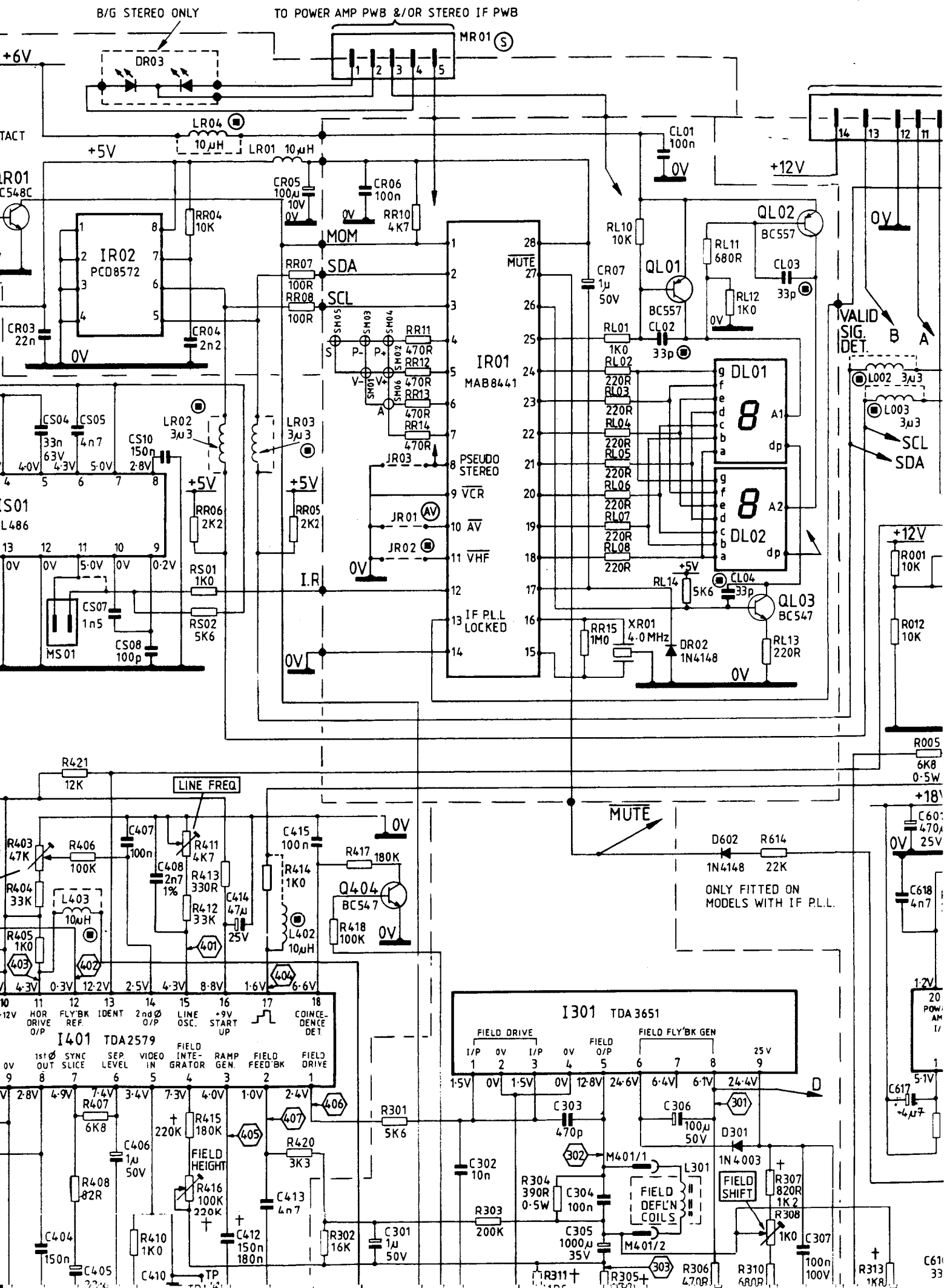

TO M152 ON AV PWB

M001 AV PWB PLUG

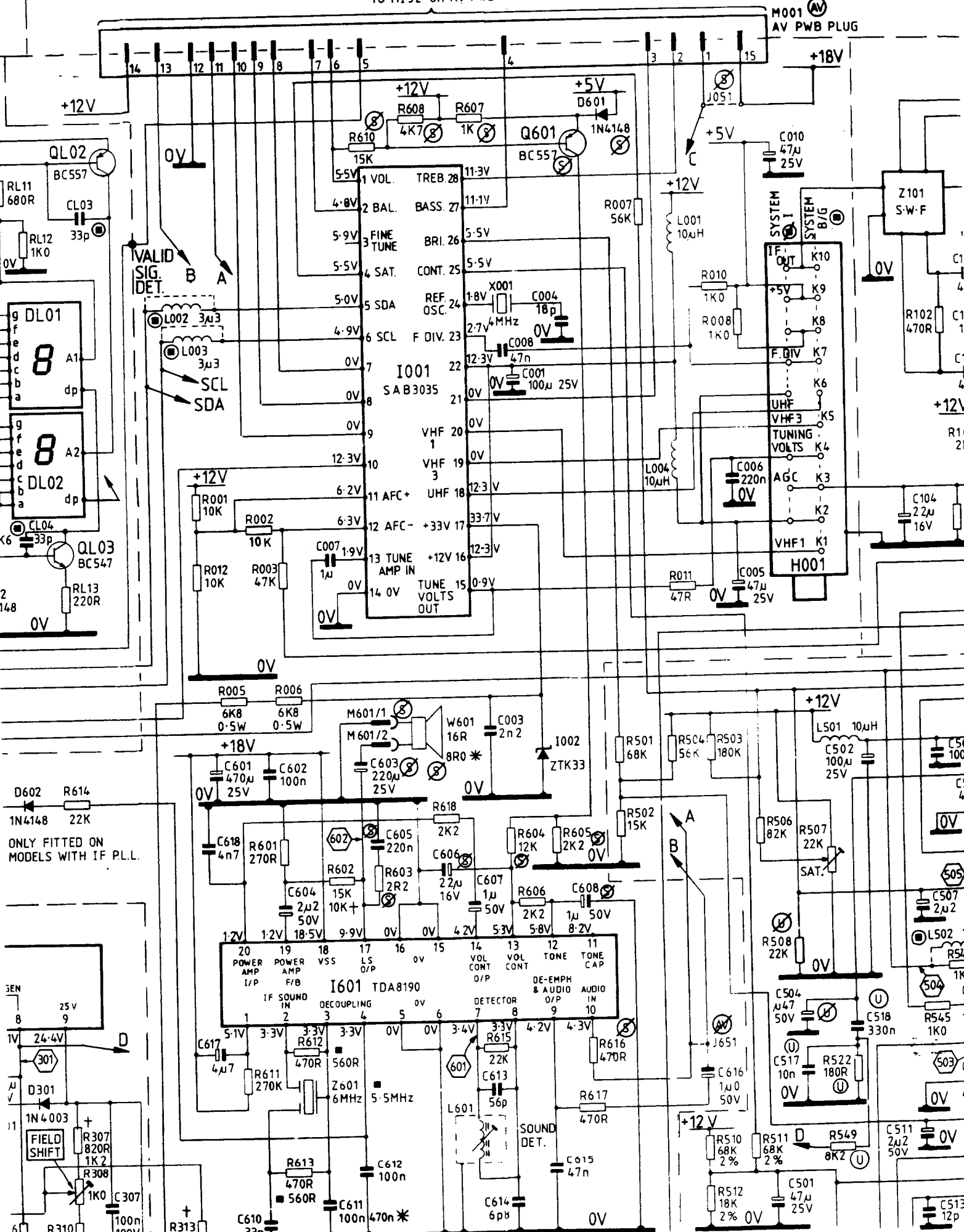

VALID SIG. DET.

ONLY FITTED ON MODELS WITH IF PLL.

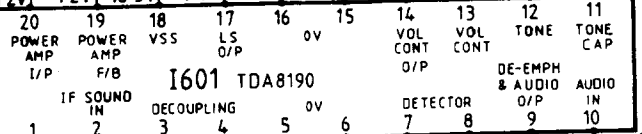

FIELD SHIFT

SOUND DET.

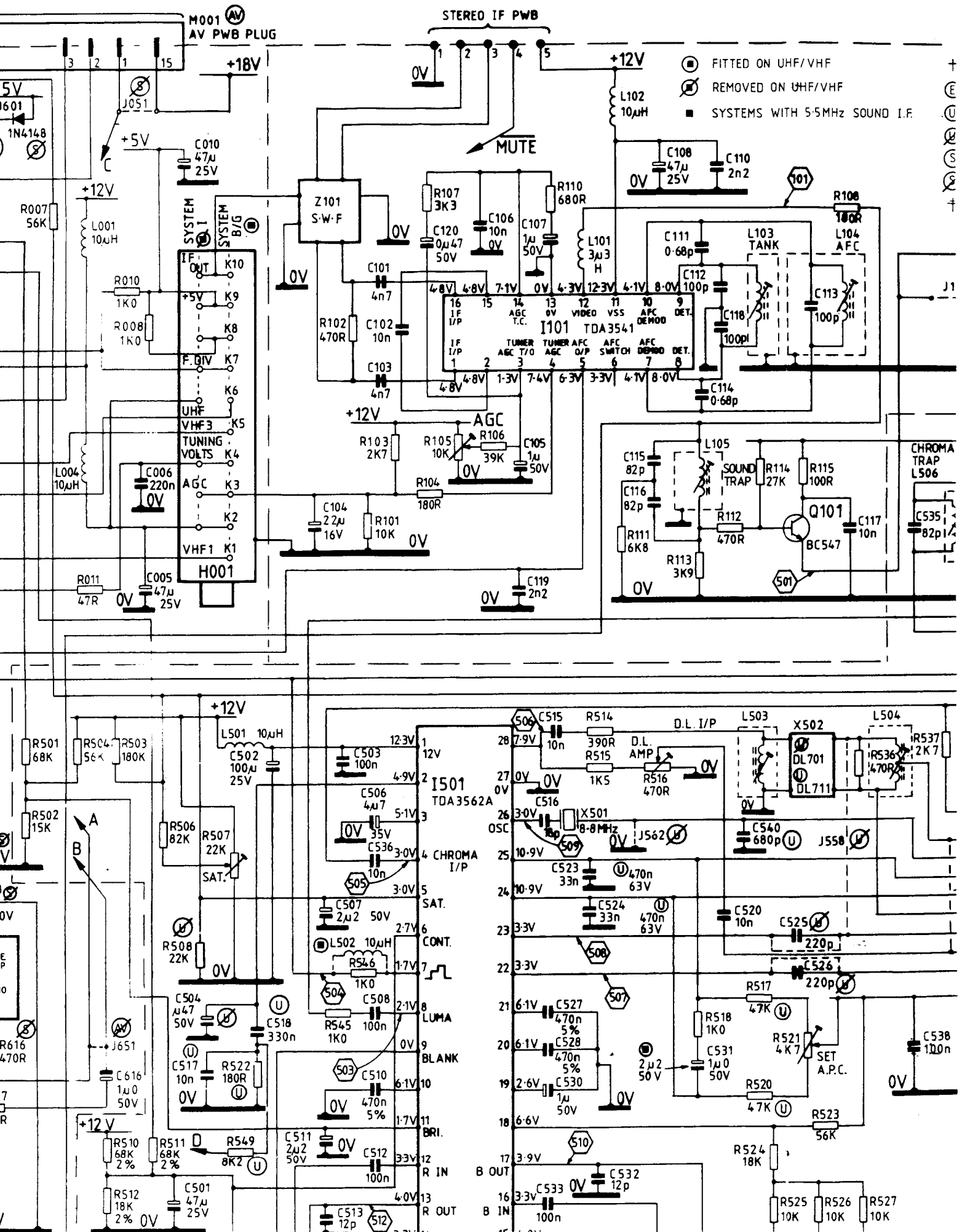

FITTED ON UHF/VHF  
 REMOVED ON UHF/VHF  
 SYSTEMS WITH 5.5MHz SOUND I.F.

- + VARIES WITH MODEL
- ⓔ MODELS FOR EIRE
- Ⓤ FITTED ON SECAM
- Ⓜ REMOVED ON SECAM
- Ⓢ STEREO
- Ⓜ MONO ONLY
- † 19" & 21" FST MODELS
- ⓧ REMOVED ON TELETEXT
- Ⓜ AV FITTED ON AV
- Ⓜ AV REMOVED ON AV
- \* MAY BE FITTED

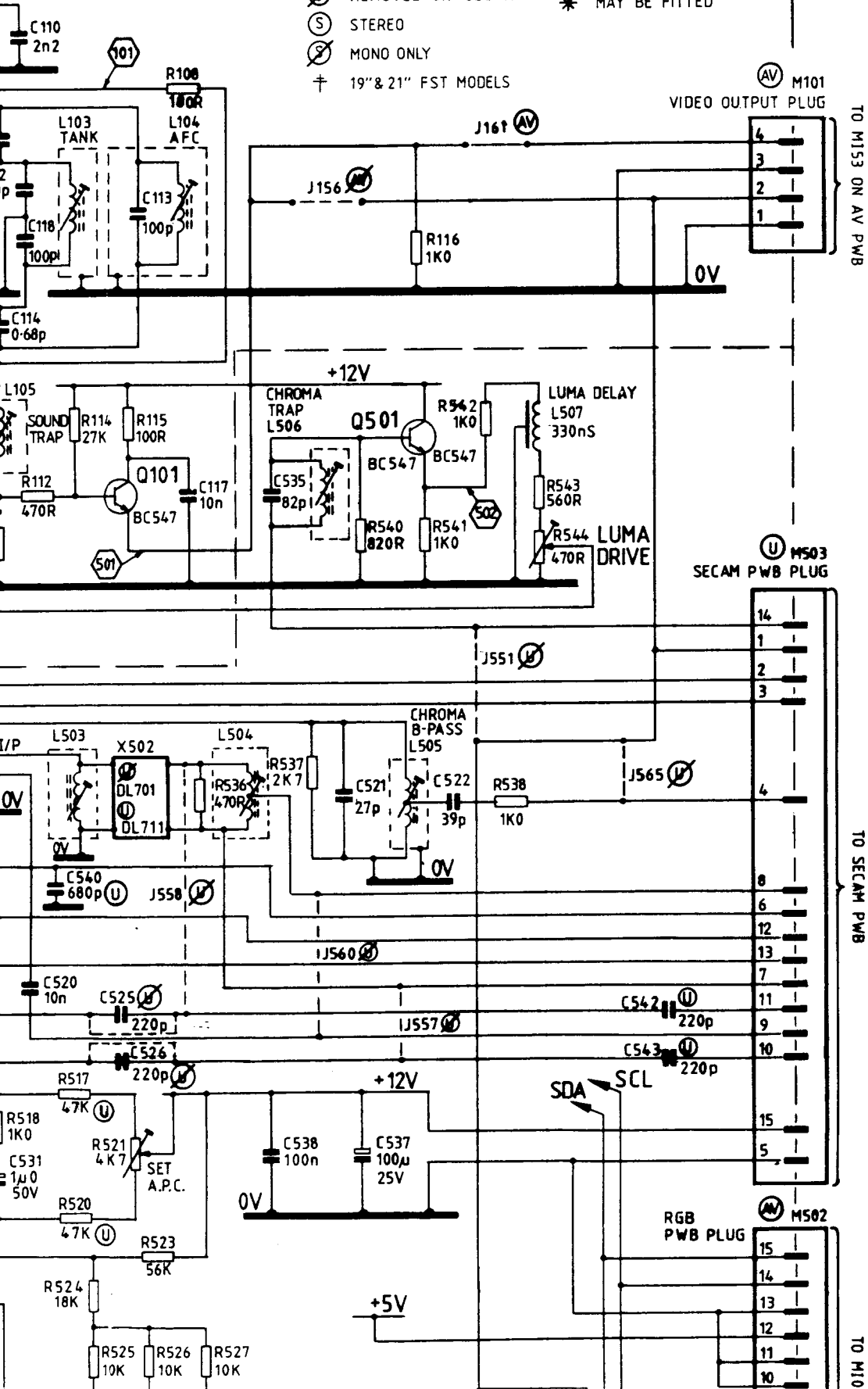

Ⓜ AV M101  
 VIDEO OUTPUT PLUG

TO M153 ON AV PWB

Ⓤ M503  
 SECAM PWB PLUG

TO SECAM PWB

Ⓜ AV M502  
 RGB PWB PLUG

TO M10



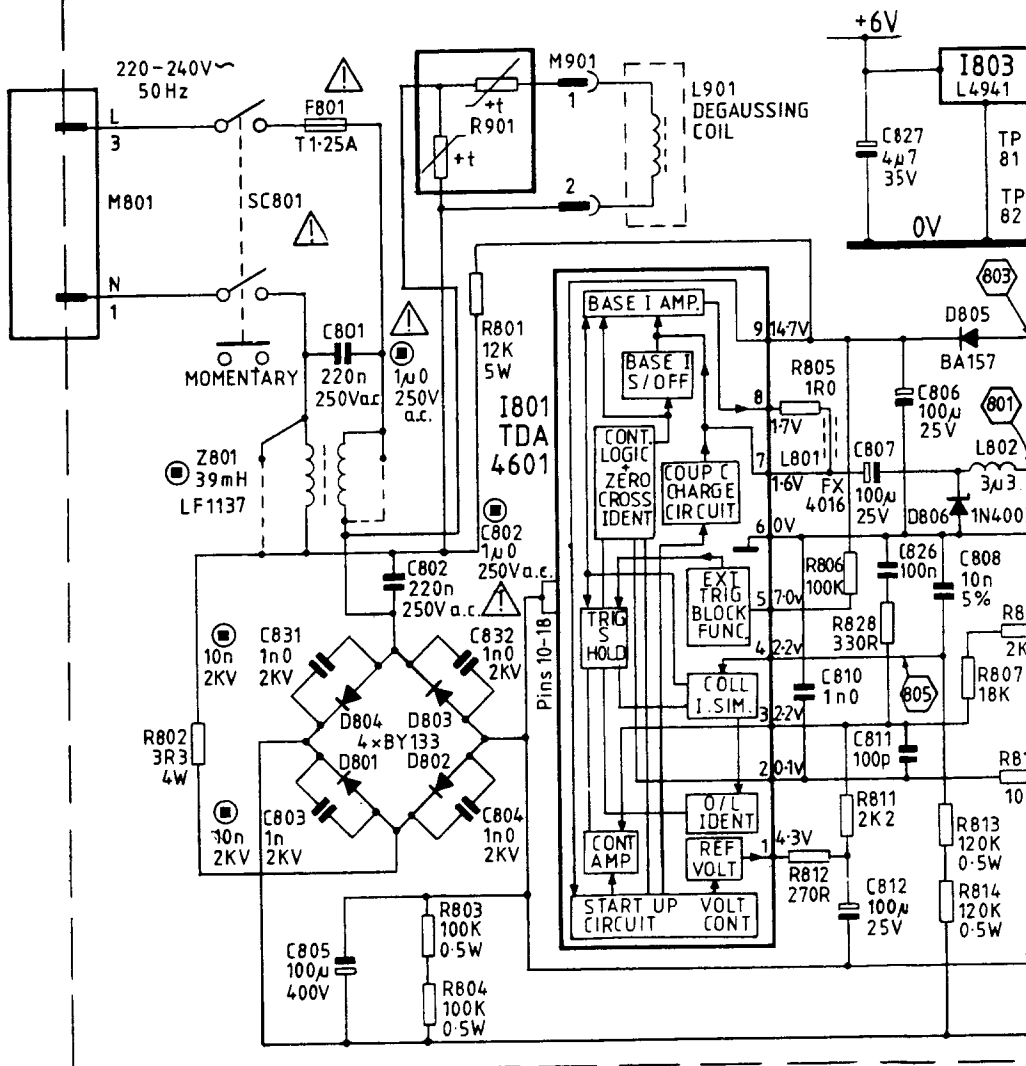
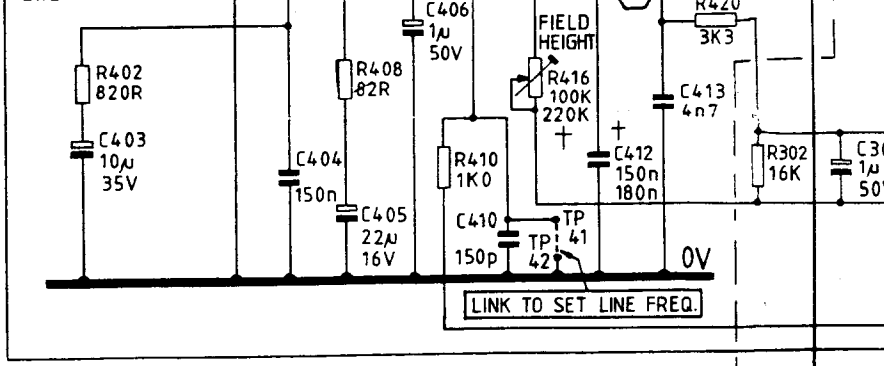
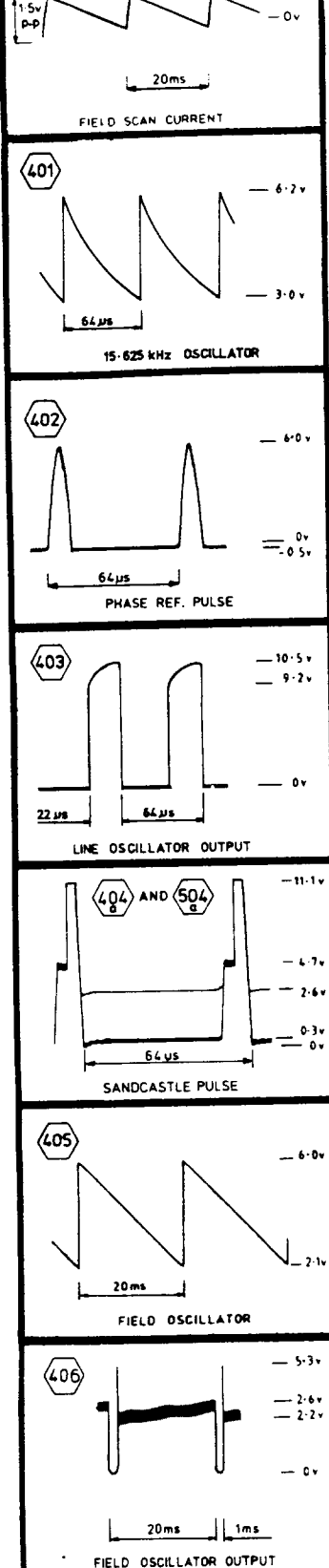

N.B. VOLTAGES AND WAVEFORMS ON I801 ARE MEASURED RELATIVE TO PIN 6 WHICH IS APPROX

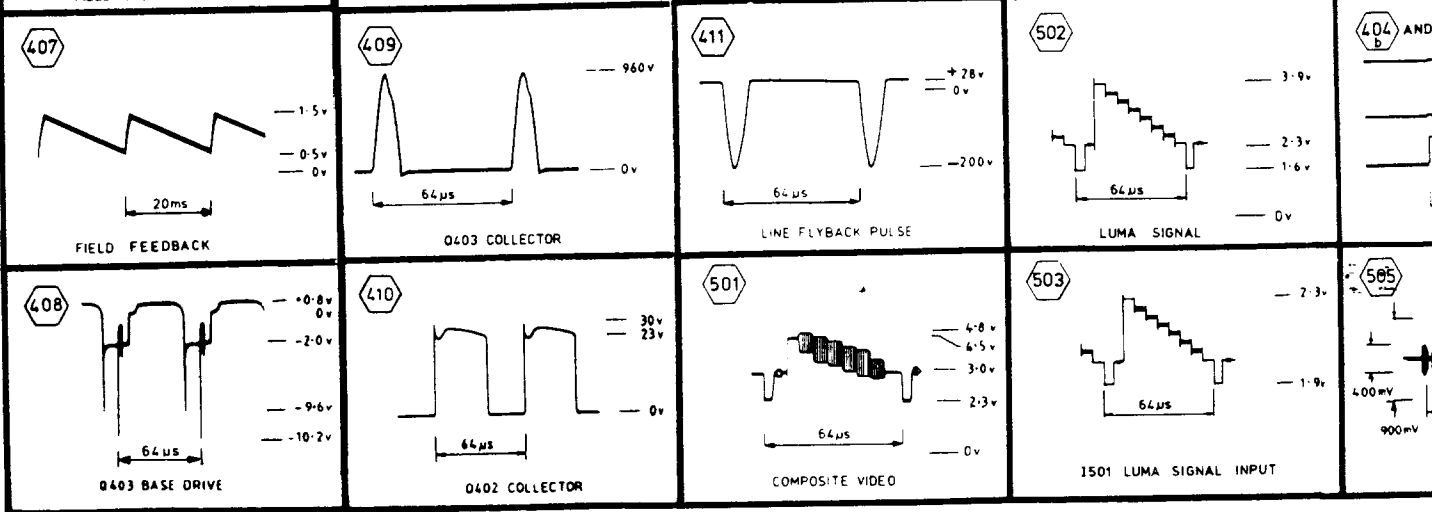

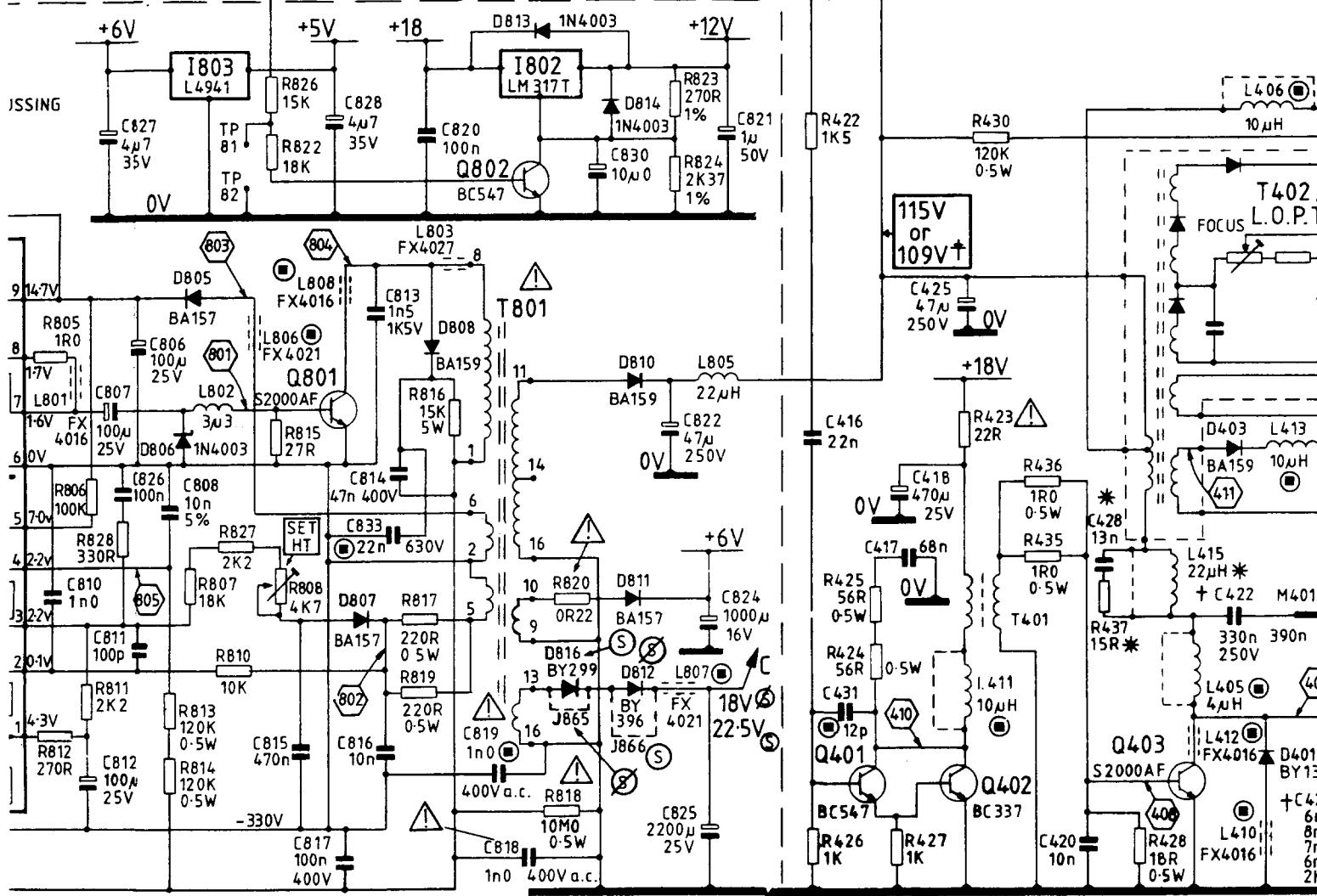
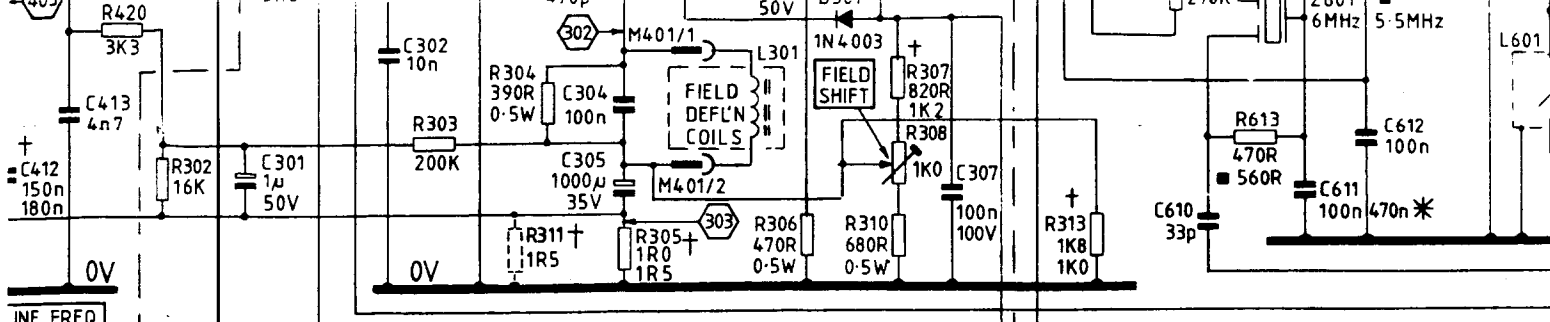

PIN 6 WHICH IS APPROX -330V RELATIVE TO CHASSIS 0V.

D.C. VOLTAGES MEASURED WITH D.V.M.

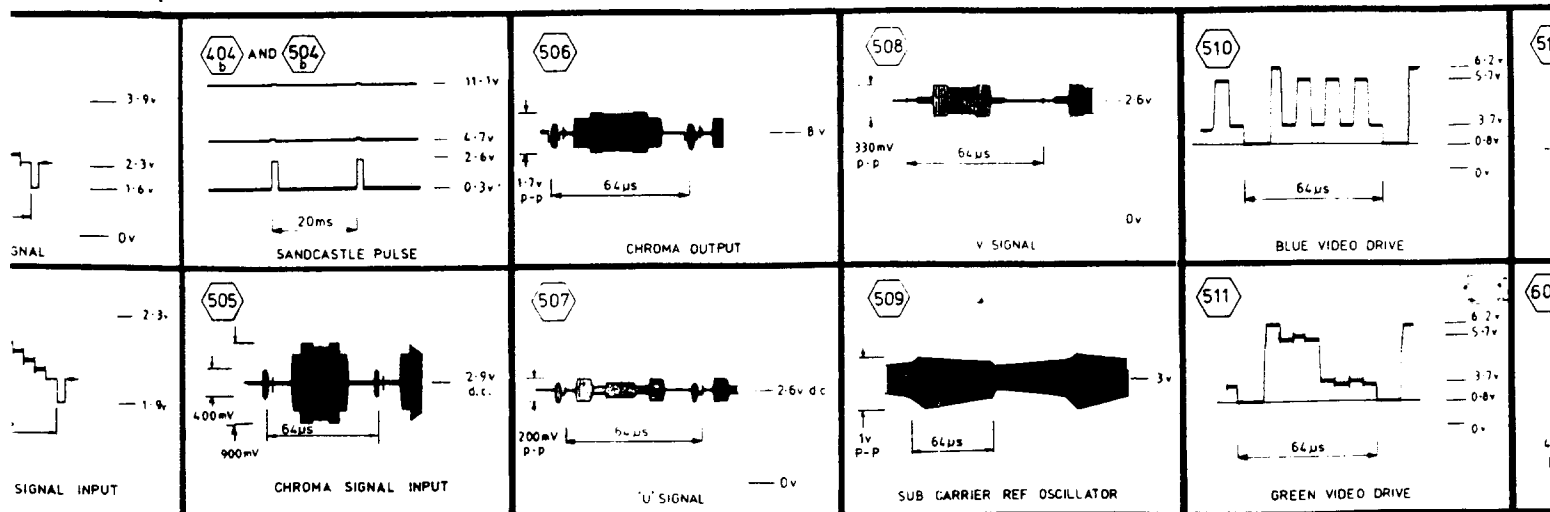

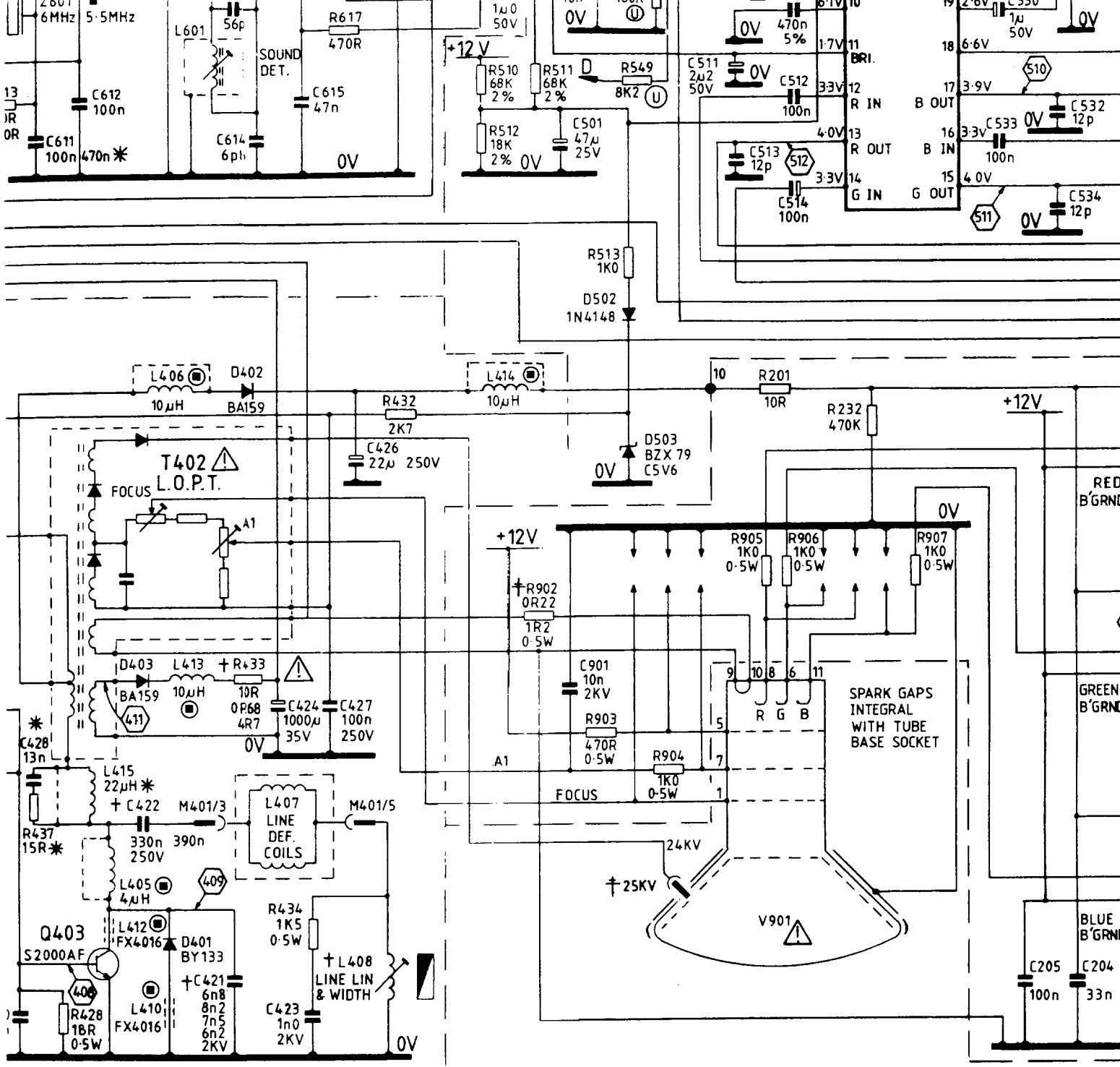

170 SERIES CHASSIS CIRCUIT DIAGRAM for systems I & II

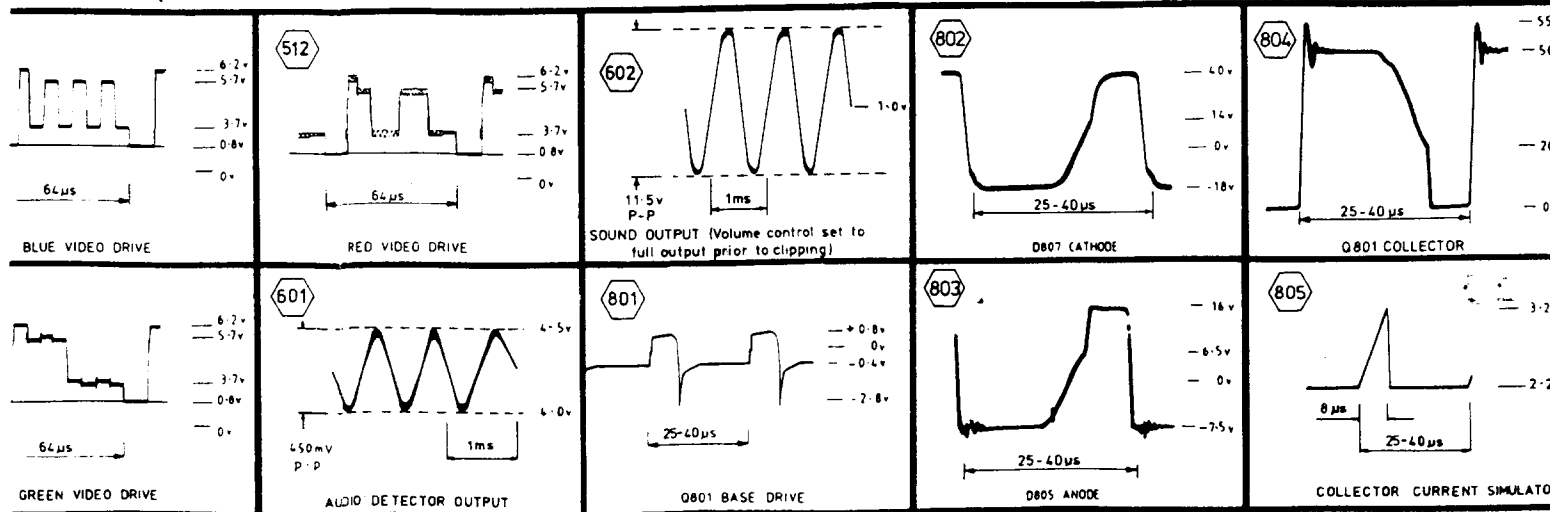

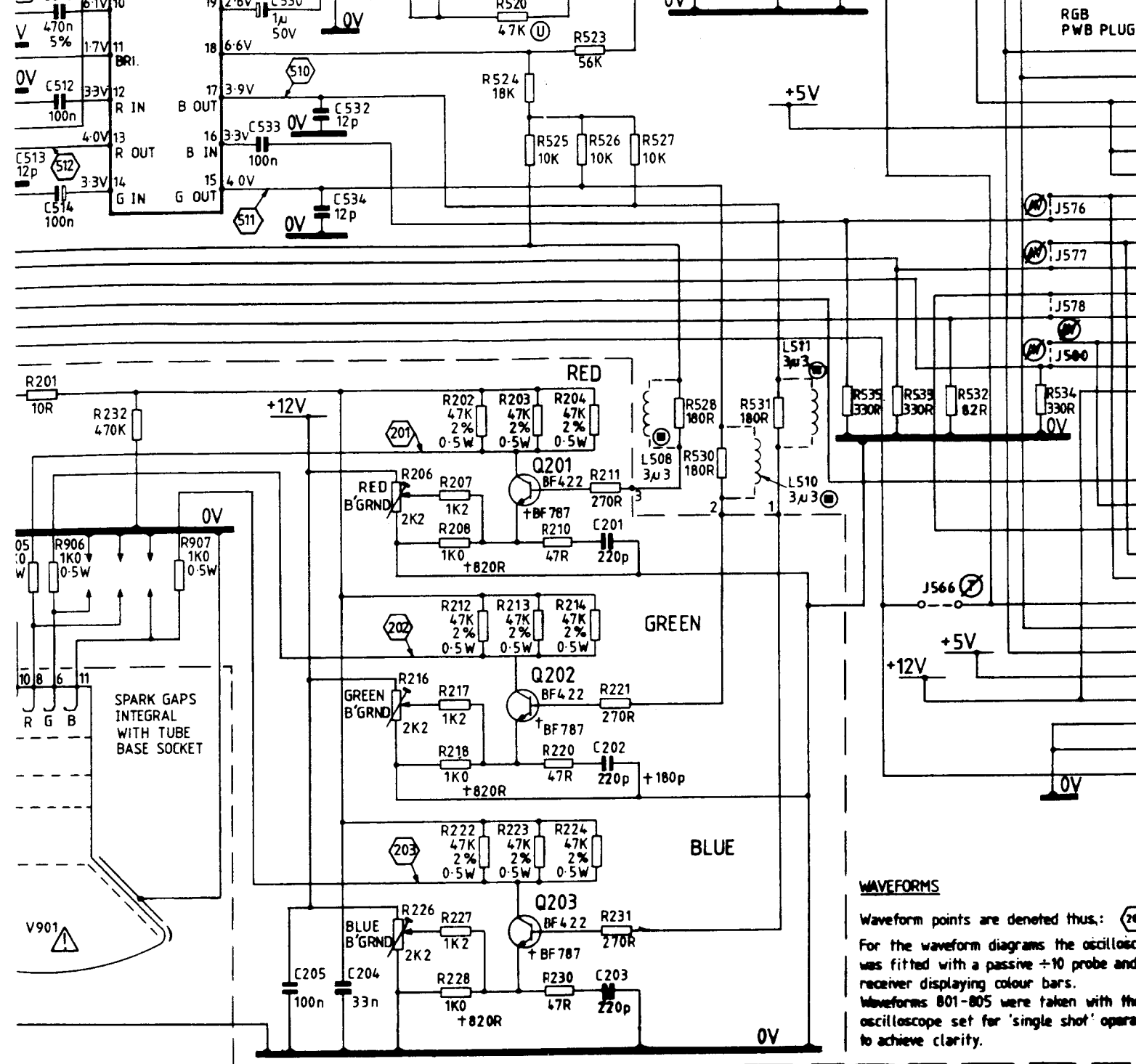

SSIS CIRCUIT DIAGRAM for systems I & B/G

DRAWING NO. 83-1989-8

ISSUE 2

DATE. 4/89

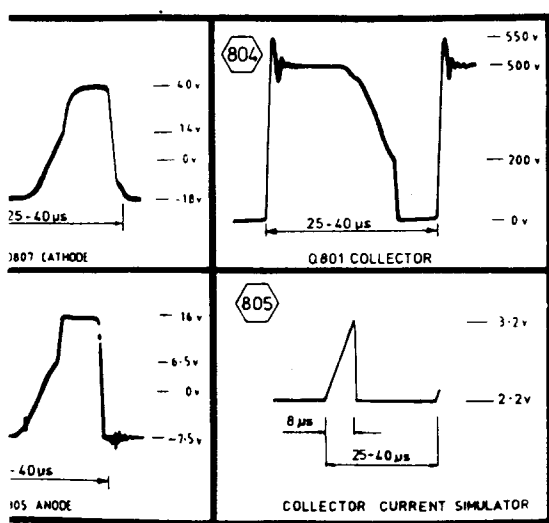

**FOR SERVICE MANUALS**  
 contact  
**MAURITRON ELECTRONICS**  
 8 Cherrytree Road, Chinnor  
 Oxon OX9 4QY.  
 Tel:- (0844) 51694

SAFETY AND ISOLATION

The power supply is always live regardless of the mains servicing, the receiver should be supplied through a main switch.

The power supply remains charged for about 30 seconds after switching off. Do not touch this area during this time.

Most of the receiver, other than the power supply, is earthed to the chassis. The air gaps between the tubes (R818, C818 (and C819 if fitted), and an air gap of 6mm between the tubes) should be checked and ensure that after repair the air gaps are not reduced.

Components marked  $\Delta$  on the parts list or circuit diagram should be replaced only with components supplied by Mauritron Electronics Department. It is recommended that other replaced parts should be the same as originally fitted, particularly resistors stood off the chassis.

**FAILURE TO OBSERVE THE ABOVE MAY RENDER THE CHASSIS A HAZARDOUS AREA OR CAUSE OTHER HAZARDS.**

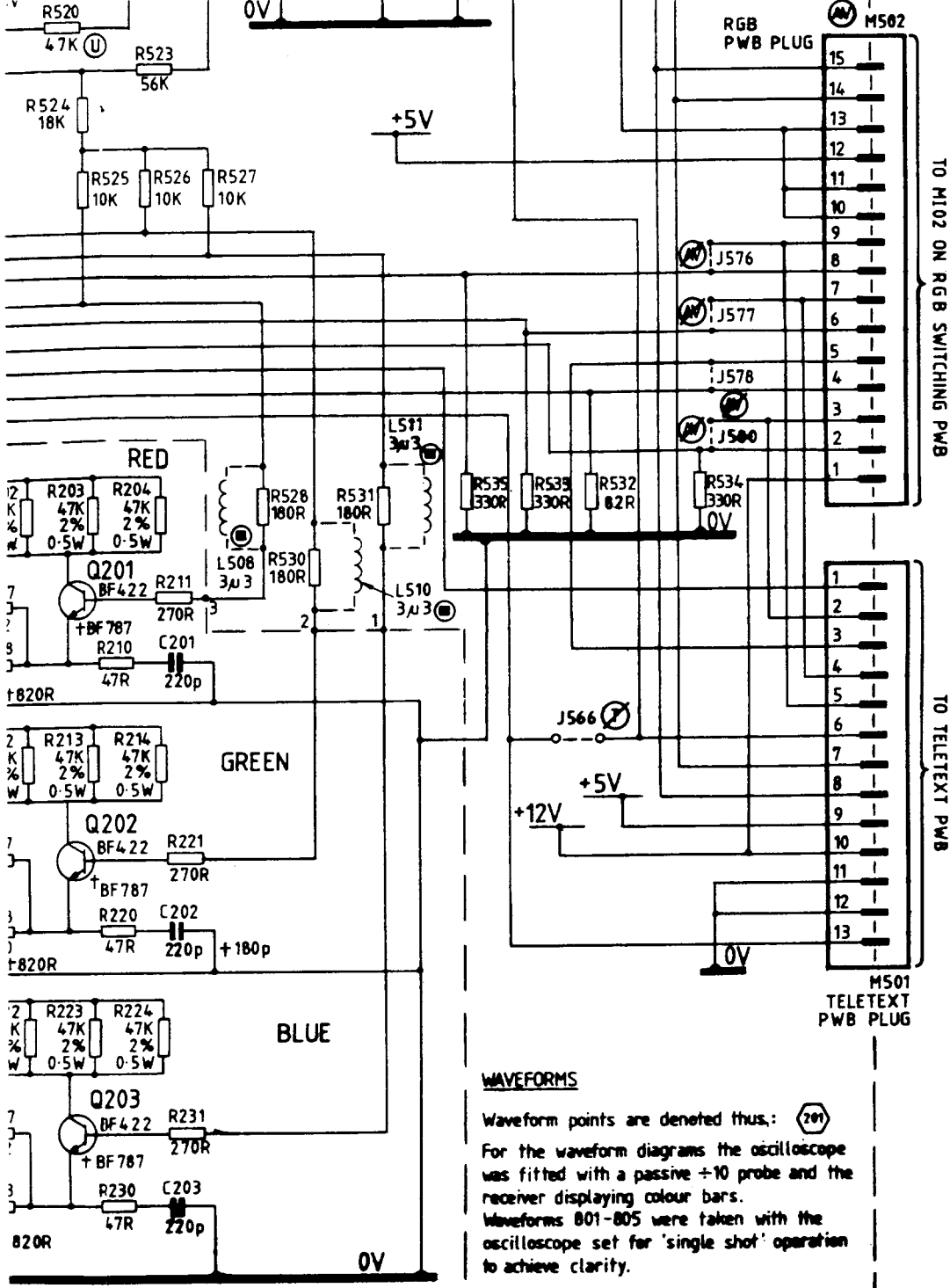

**WAVEFORMS**

Waveform points are denoted thus:  $\textcircled{201}$   
 For the waveform diagrams the oscilloscope was fitted with a passive +10 probe and the receiver displaying colour bars. Waveforms 801-805 were taken with the oscilloscope set for 'single shot' operation to achieve clarity.

DRAWING NO. 83-1989-8      ISSUE 2      DATE. 4/89

**R SERVICE MANUALS**  
 contact  
**URITRON ELECTRONICS**  
 herrytree Road, Chinnor  
 Oxon OX9 4QY.  
 Tel:- (0844) 51694

**SAFETY AND ISOLATION**

The power supply is always live regardless of the mains supply polarity. Therefore, for servicing, the receiver should be supplied through a mains isolation transformer.

The power supply remains charged for about 30 seconds after switch off. Avoid touching this area during this time.

Most of the receiver, other than the power supply, is isolated from the mains by T801, R818, C818 (and C819 if fitted), and an air gap of 6mm or more. To maintain safety, ensure that after repair the air gaps are not reduced by protruding wires, etc.

Components marked  $\triangle$  on the parts list or circuit diagram are safety approved types and should be replaced only with components supplied, or approved by, our Service Department. It is recommended that other replaced parts should be of the type originally fitted, particularly resistors stood off the printed board.

FAILURE TO OBSERVE THE ABOVE MAY RENDER THE CHASSIS AND EXTERNAL ACCESSIBLE PARTS LIVE, OR CAUSE OTHER HAZARDS.

B/G STEREO ONLY

TO POWER AMP

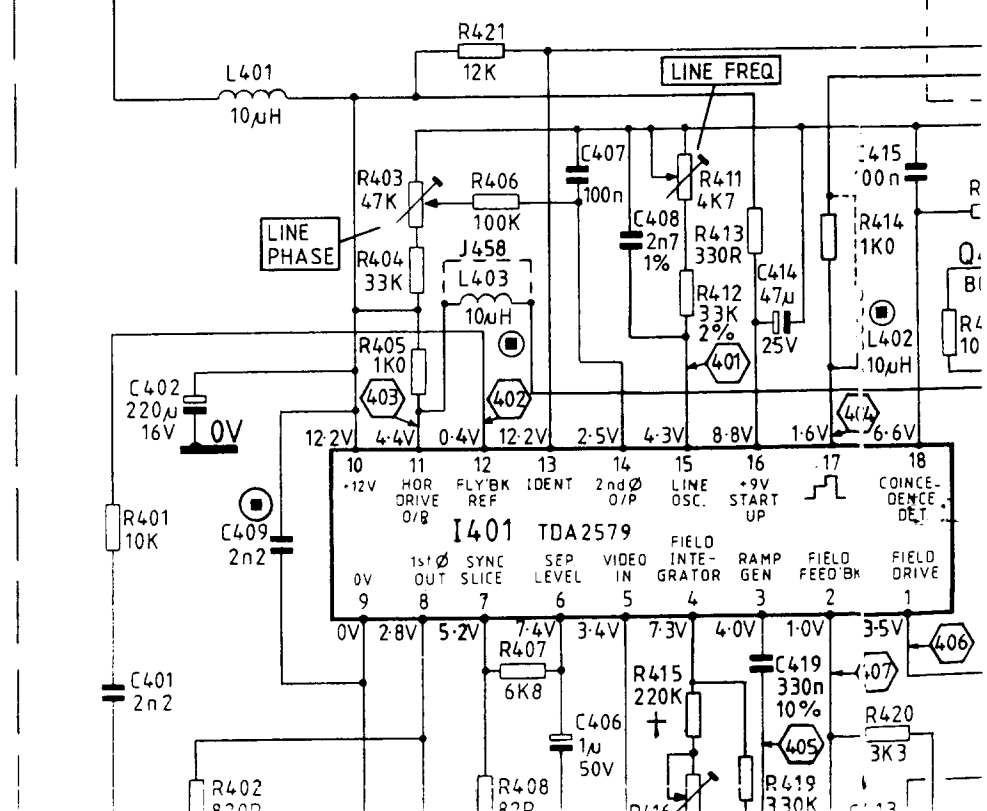
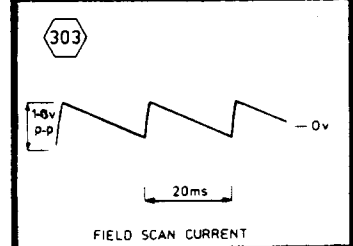
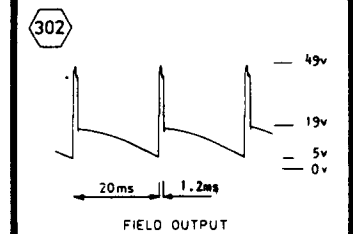
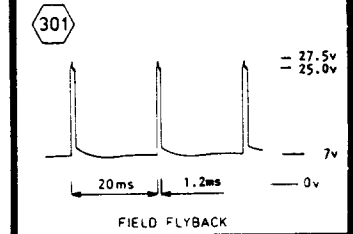
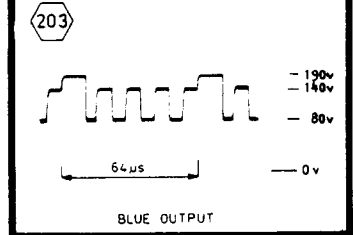
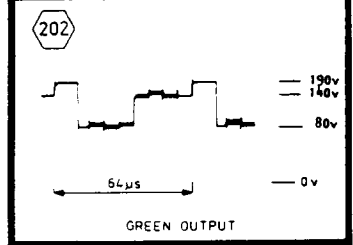
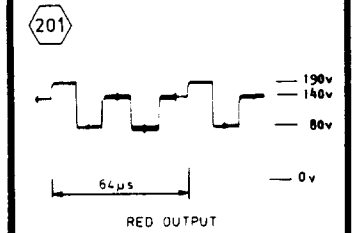
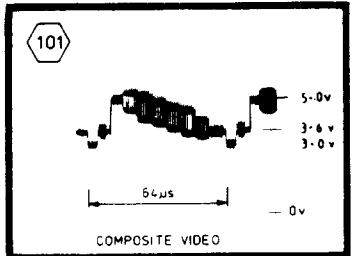
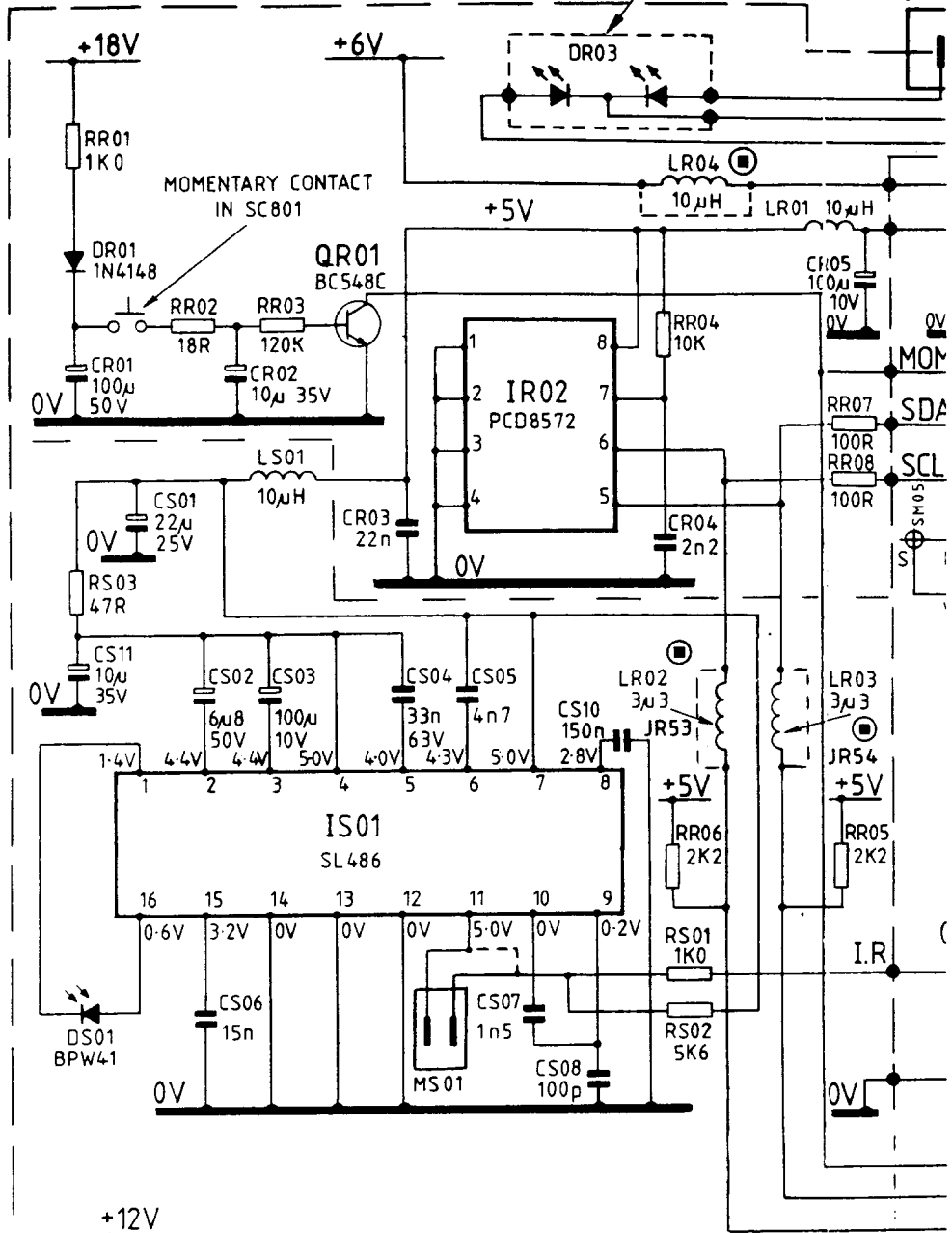

EO ONLY

TO POWER AMP PWB &/OR STEREO IF PWB

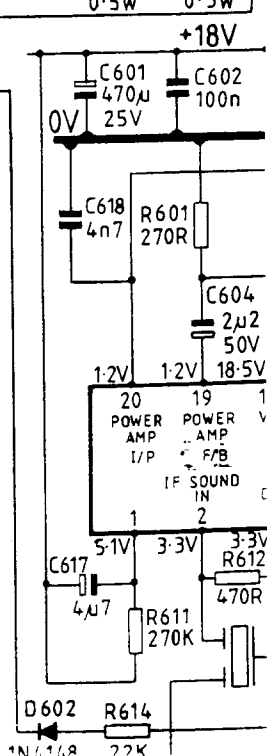
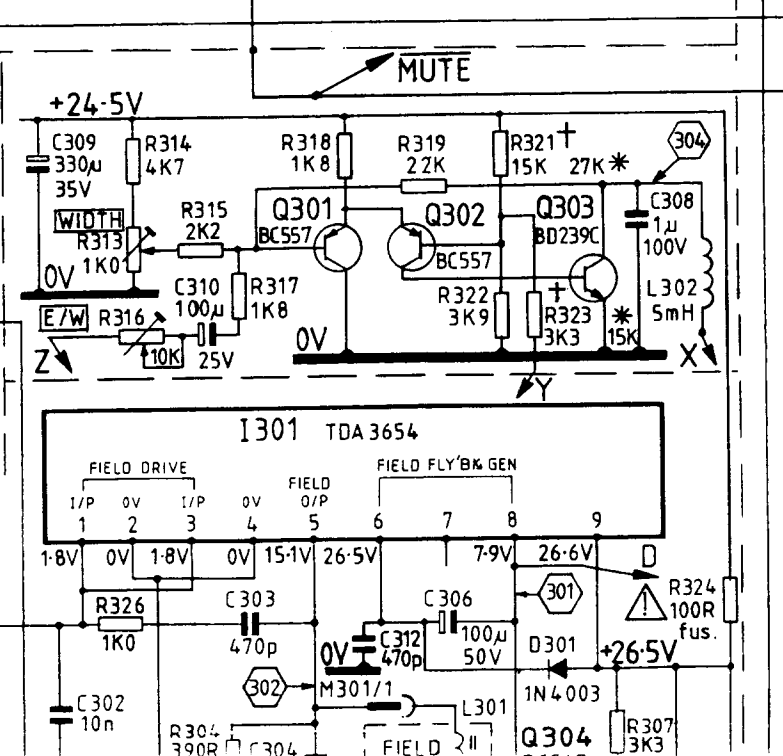
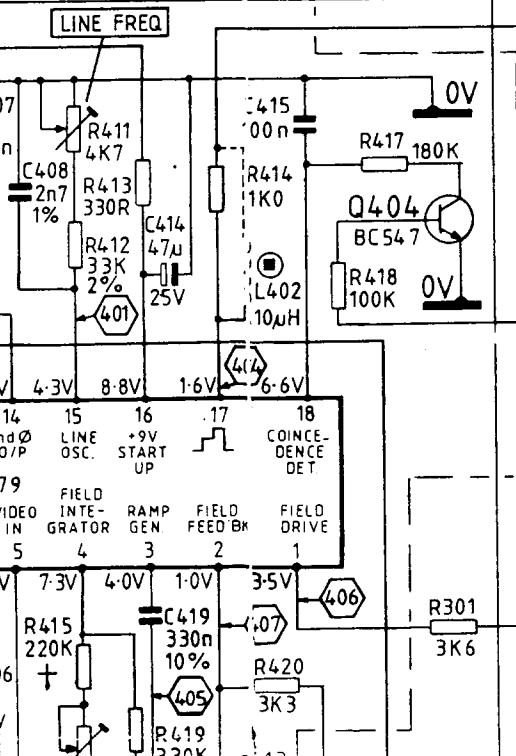
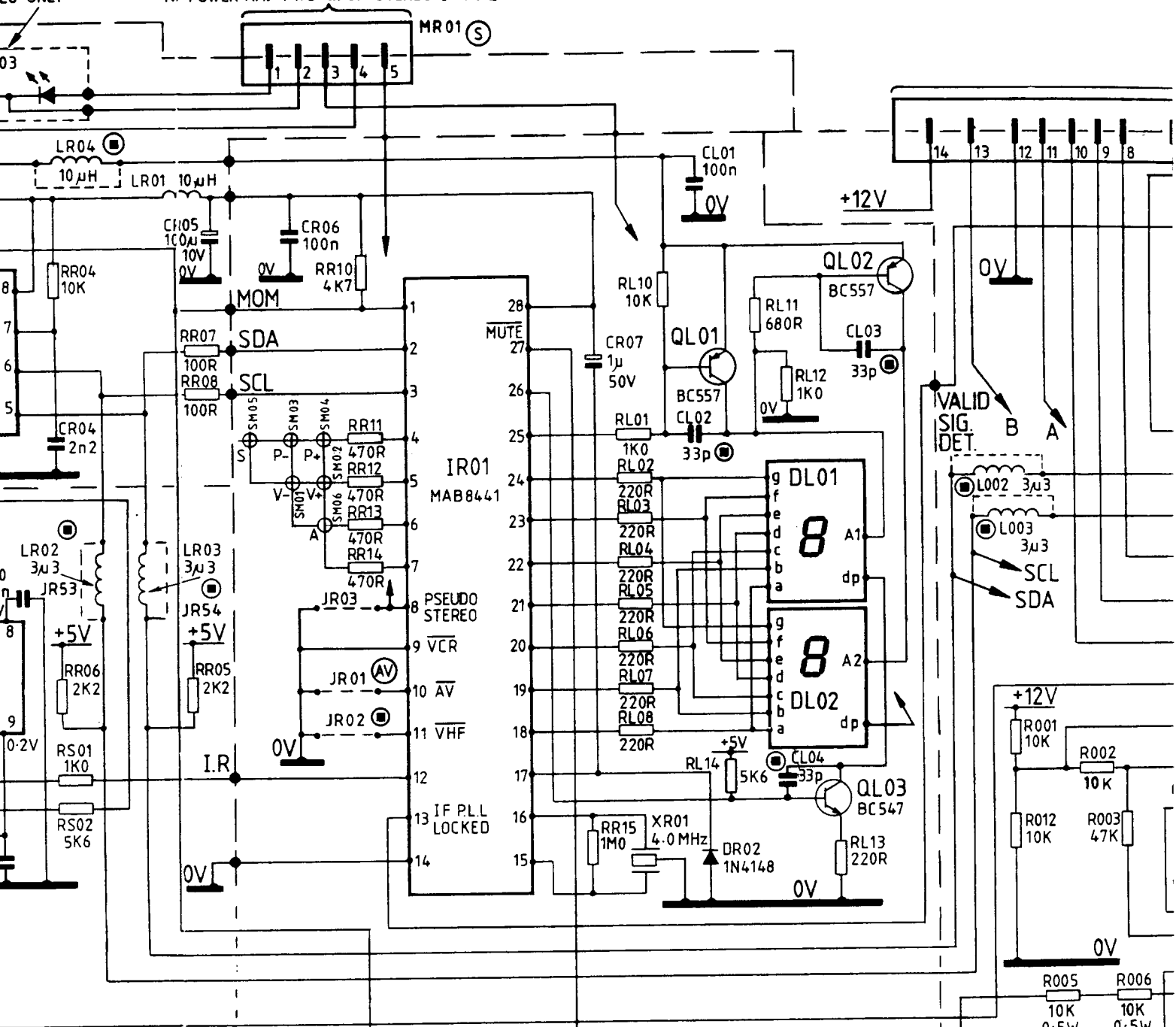

TO MI52 ON AV PWB

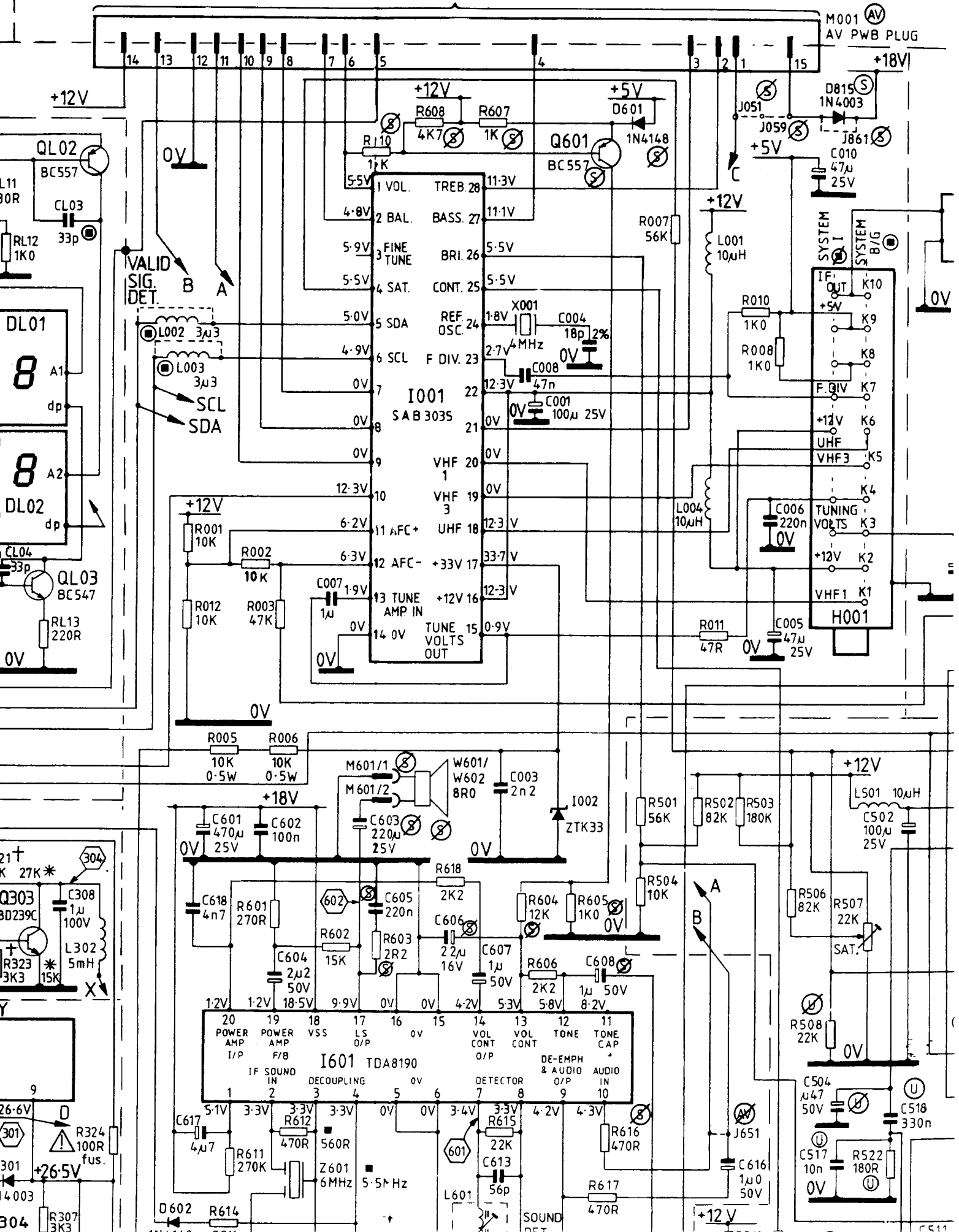



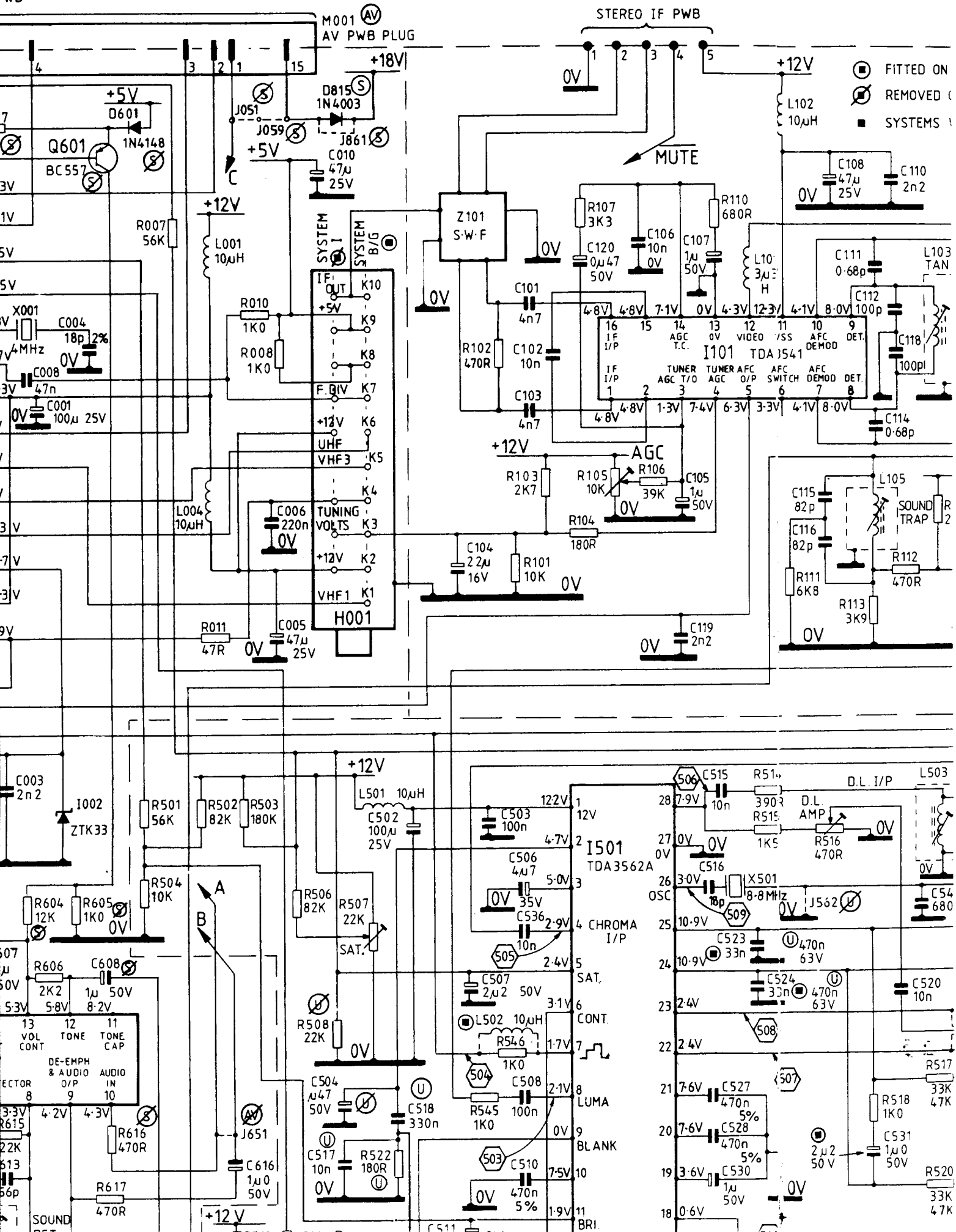



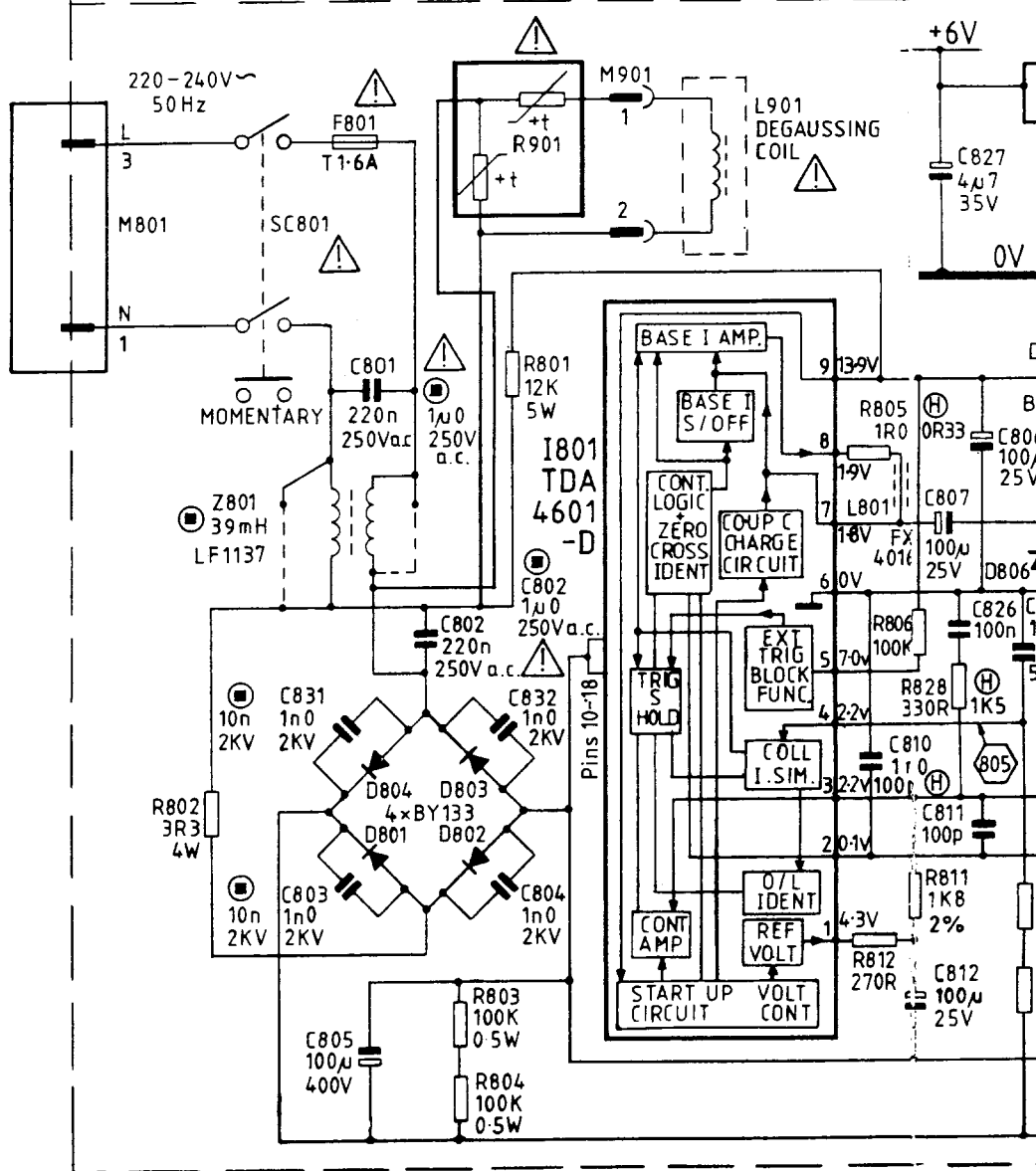
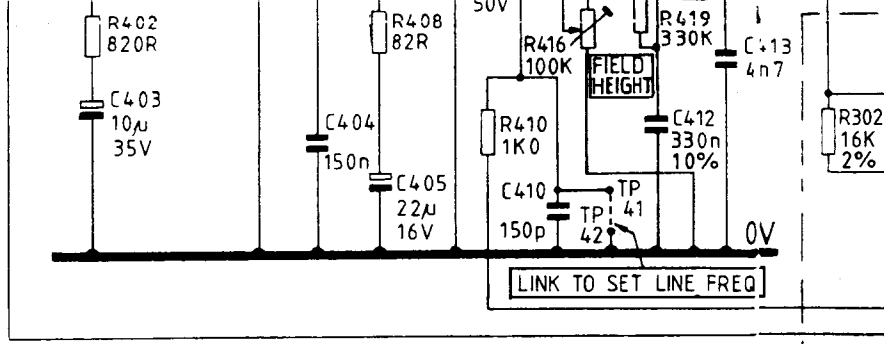
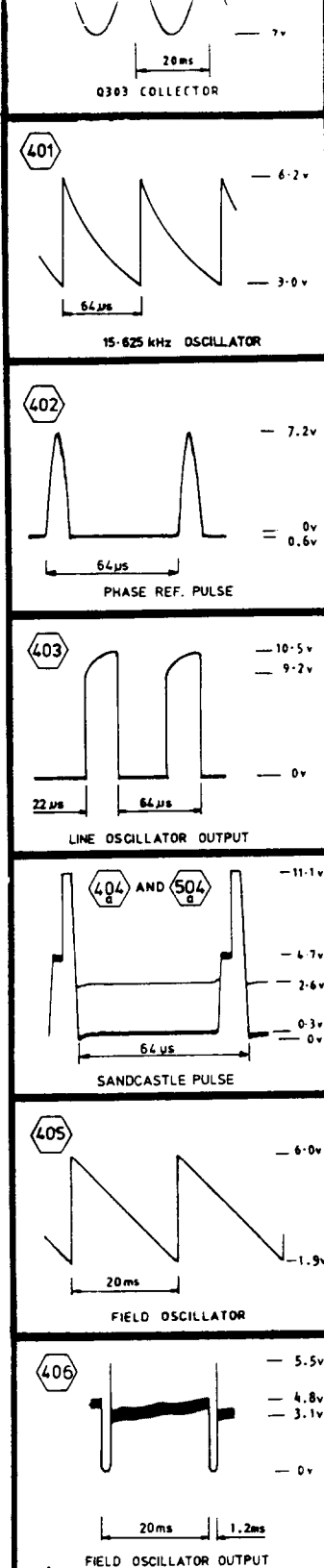

N.B. VOLTAGES AND WAVEFORMS ON I801 ARE MEASURED RELATIVE TO PIN 6 WHICH IS AP

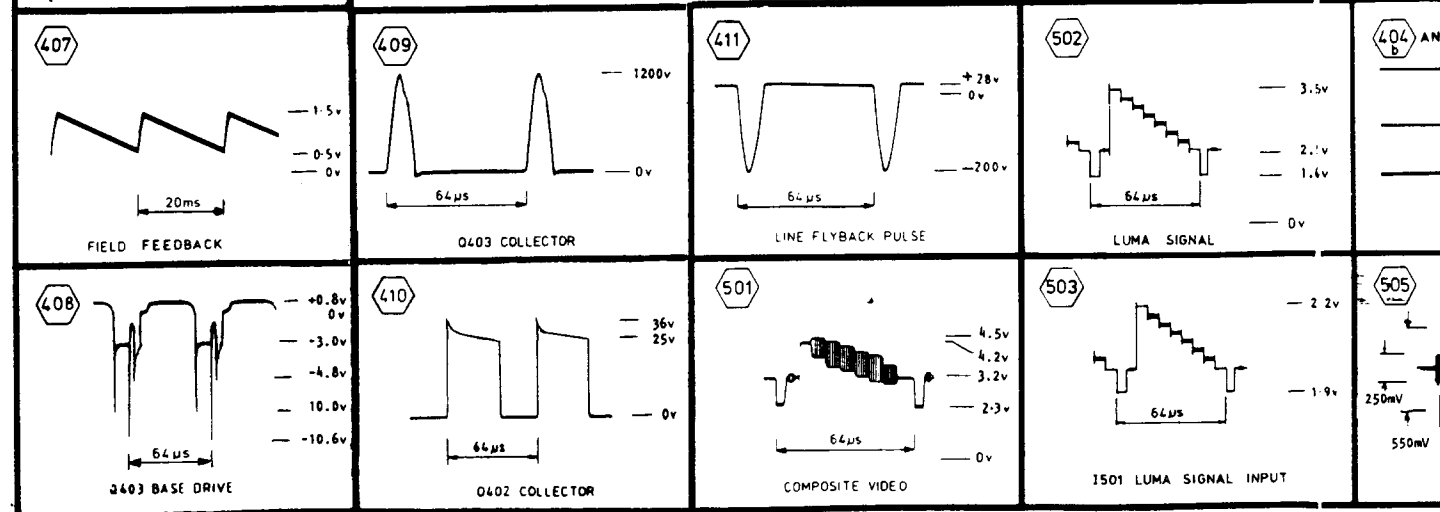



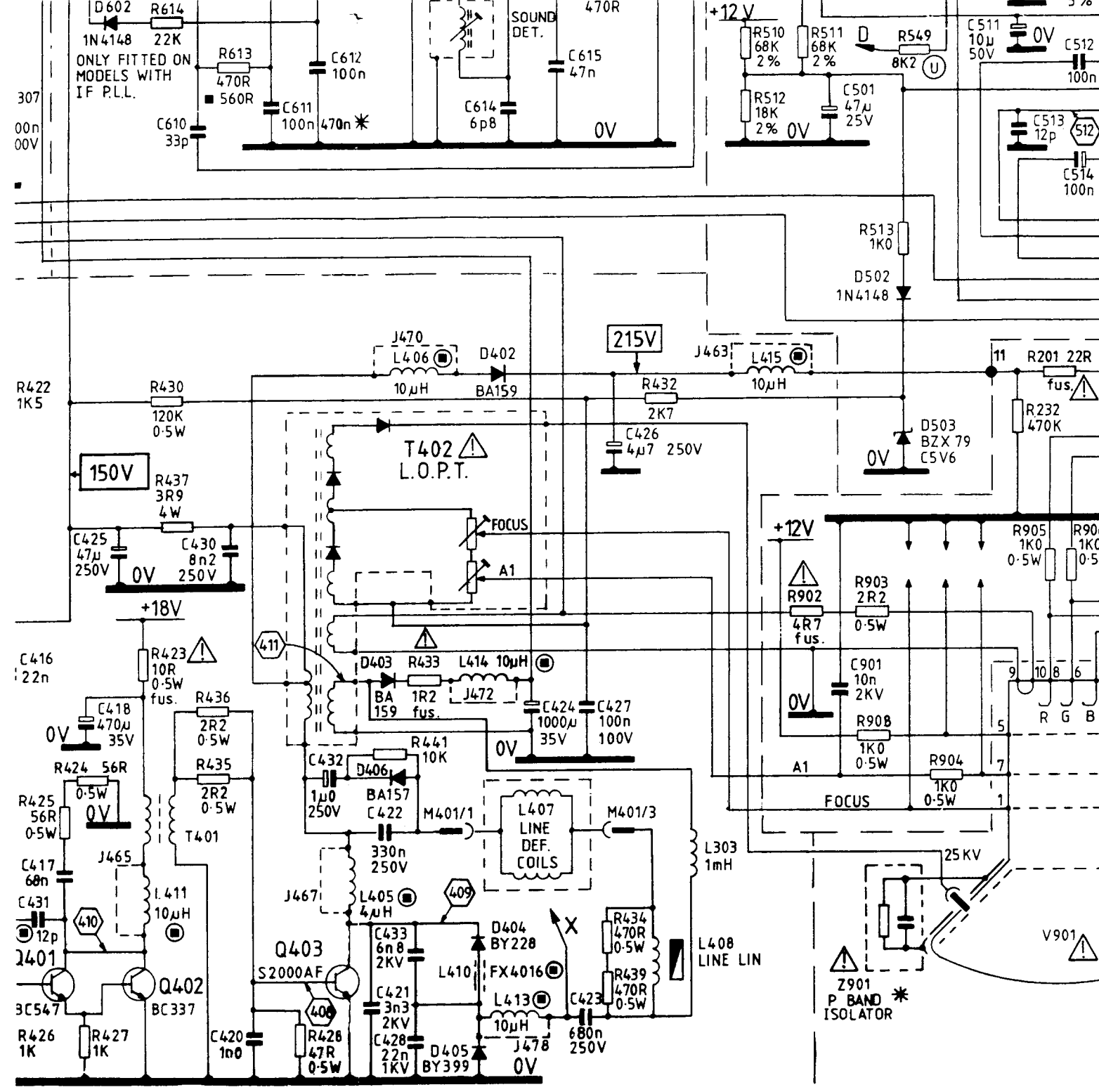

VOLTAGES MEASURED WITH D.V.M.

180 SERIES CHASSIS C

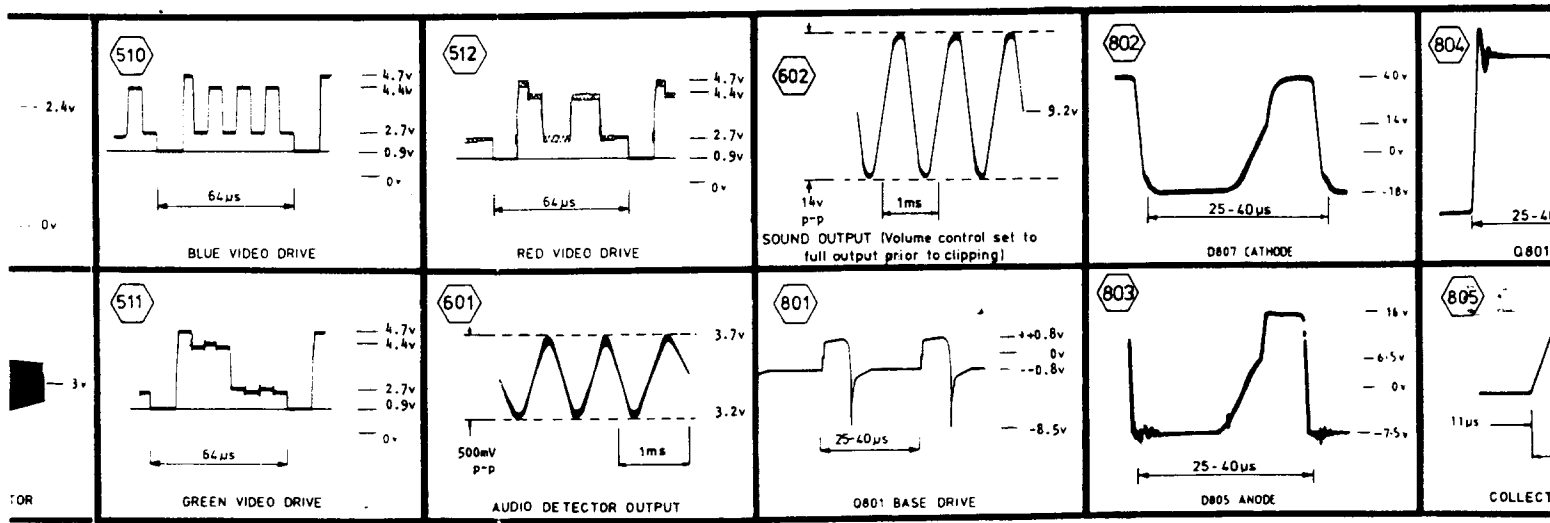

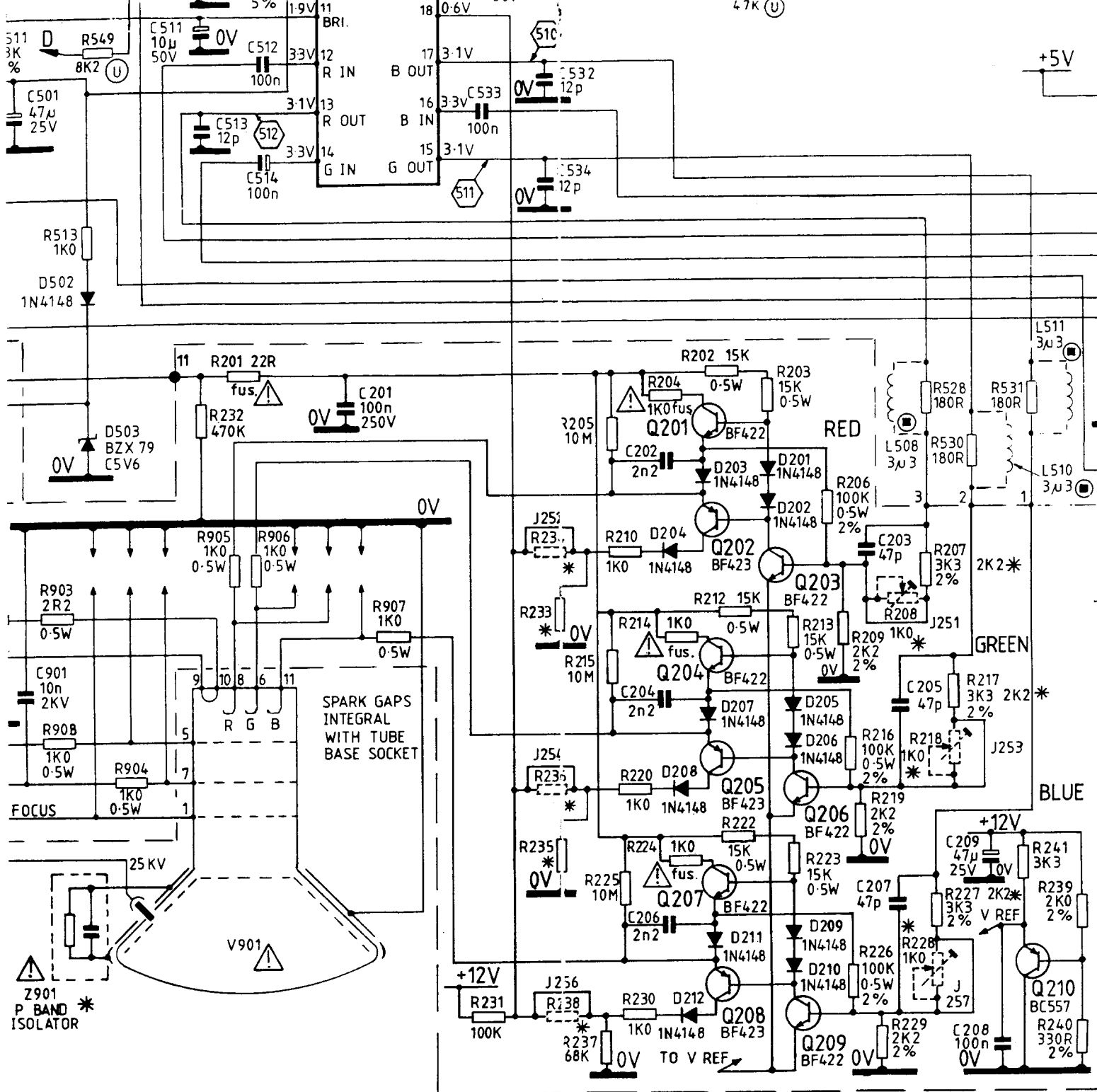

180 SERIES CHASSIS CIRCUIT DIAGRAM for systems I & B/G

DRAWING NO. 83-2683-5

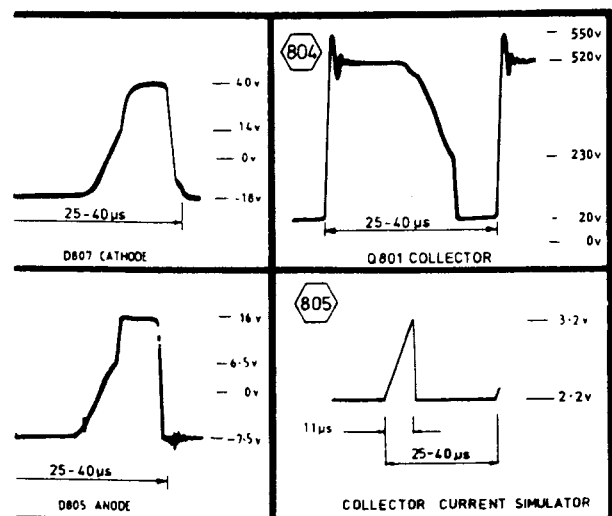

SAFETY AND ISOLATION

The power supply is always live regardless of the servicing, the receiver should be supplied through a fuse.

The power supply remains charged for about 30 seconds after touching this area during this time.

Most of the receiver, other than the power supply, is protected by a 25KV spark gap (V901) and an air gap (R181, C818 (and C819 if fitted), and an air gap (R240) ensure that after repair the air gaps are not removed.

Components marked  $\Delta$  on the parts list or circuit diagram and should be replaced only with components supplied by the Department. It is recommended that other replacement components be of the same type as originally fitted, particularly resistors stood off.

FAILURE TO OBSERVE THE ABOVE MAY RENDER THE CHASSIS INOPERATIVE OR CAUSE OTHER HAZARDS.

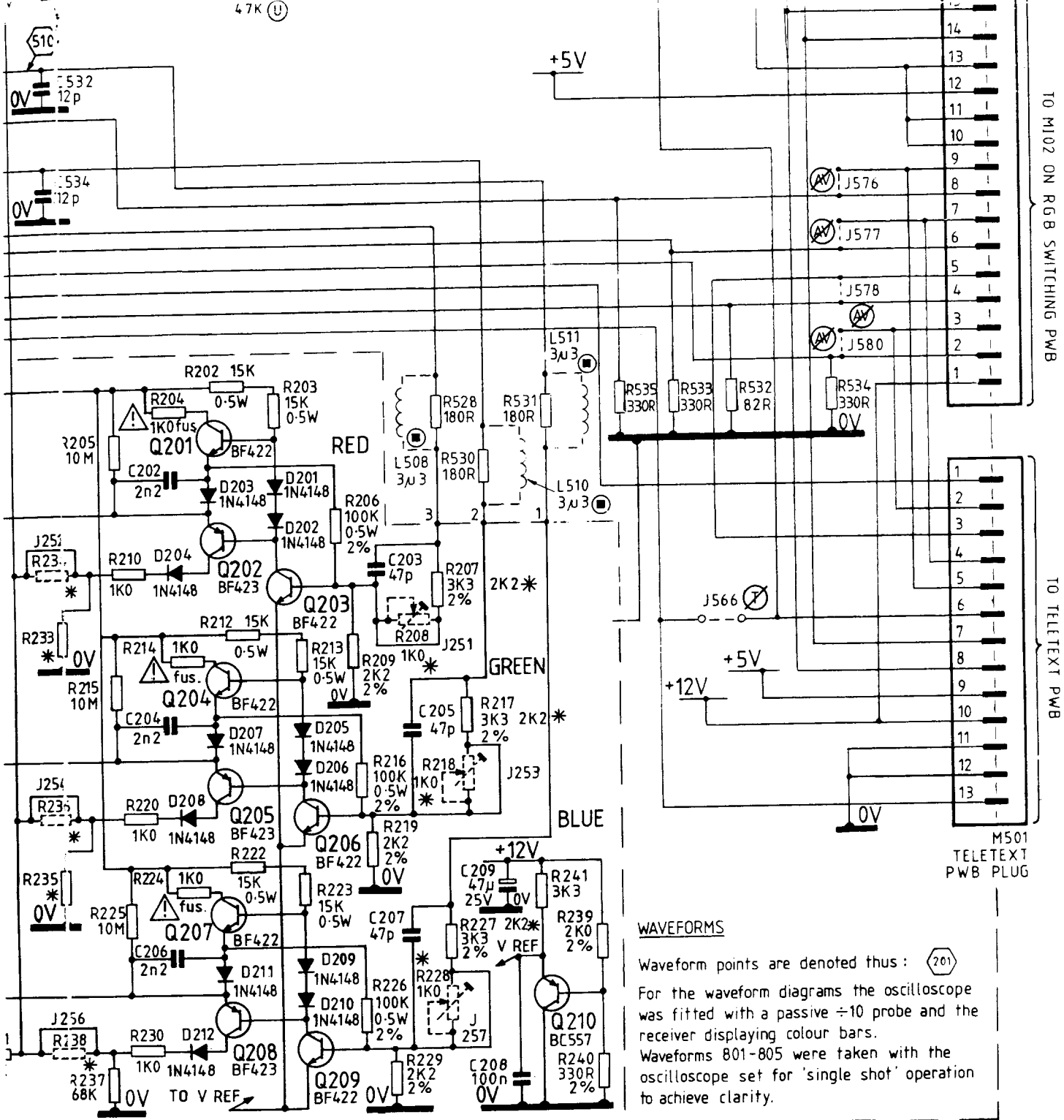

**WAVEFORMS**

Waveform points are denoted thus: (201)

For the waveform diagrams the oscilloscope was fitted with a passive  $\times 10$  probe and the receiver displaying colour bars.

Waveforms 801-805 were taken with the oscilloscope set for 'single shot' operation to achieve clarity.

systems I & B/G

DRAWING NO. 83-2683-5

ISSUE 2

DATE 4/88

**SAFETY AND ISOLATION**

The power supply is always live regardless of the mains supply polarity. Therefore, for servicing, the receiver should be supplied through a mains isolation transformer.

The power supply remains charged for about 30 seconds after switch off. Avoid touching this area during this time.

Most of the receiver, other than the power supply, is isolated from the mains by T801, R818, C818 (and C819 if fitted), and an air gap of 6mm or more. To maintain safety, ensure that after repair the air gaps are not reduced by protruding wires, etc.

Components marked  $\Delta$  on the parts list or circuit diagram are safety approved types and should be replaced only with components supplied, or approved by, our Service Department. It is recommended that other replaced parts should be of the type originally fitted, particularly resistors stood off the printed board.

FAILURE TO OBSERVE THE ABOVE MAY RENDER THE CHASSIS AND EXTERNAL ACCESSIBLE PARTS LIVE, OR CAUSE OTHER HAZARDS.