

# ROADSTAR

# 11AK19PRO

---

MODEL

---

SERVICE MANUAL

---

## DO NOT CHANGE ANY MODULE UNLESS THE SET IS SWITCH OFF

The mains supply side of the switch mode power supply transformer is live.

Use an isolating transformer.

The receivers fulfill completely the safety requirements.

### Safety precautions:

Servicing of this TV should only be carried out by a qualified person.

- Components marked with the warning symbol on the circuit diagram are critical for safety and must only be replaced with an identical component.

- Power resistor and fusible resistors must be mounted in an identical manner to the original component.

- When servicing this TV, check that the EHT does not exceed 26kV.

### TV Set switched off:

Make short-circuit between HV-CRT clip and CRT ground layer.

Short C804 (150mF) before changing IC802 or other components in primary side of SMPS.

### Measurements:

Voltage readings and oscilloscope traces are measured under following conditions.

Antenna signal 60dB from colourbar generator. (100% white, 75% colour saturation)

Brightness, contrast, colour set for a normal picture.

Mains supply, 220VAC, 50Hz.

## PERI-TV SOCKET

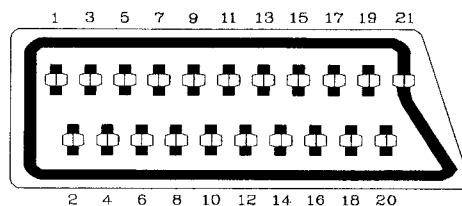

### SCART 1 (SC050)

1	Audio right output	0.5Vrms / 1K
2	Audio right input	0.5Vrms / 10K
3	Audio left output	0.5Vrms / 1K
4	Ground AF	
5	Ground Blue	
6	Audio left input	0.5Vrms / 10K
7	Blue input	0.7Vpp / 75ohm
8	AV switching input	0-12VDC / 10K
9	Ground Green	
10	-	
11	Green input	0.7Vpp / 75ohm
12	-	
13	Ground Red	
14	Ground Blanking	
15	Red input	0.7Vpp / 75ohm
16	Blanking input	0-0.4VDC, 1-3VDC / 75ohm
17	Ground CVS output	
18	Ground CVS input	
19	CVS output	1Vpp / 75ohm
20	CVS input	1Vpp / 75ohm
21	Ground	

### SCART 2 (SC051)

1	Audio right output	0.5Vrms / 1K
2	Audio right input	0.5Vrms / 10K
3	Audio left output	0.5Vrms / 1K
4	Ground AF	
5	Ground Blue	
6	Audio left input	0.5Vrms / 10K
7	Blue input	0.7Vpp / 75ohm
8	AV switching input	0-12VDC / 10K
9	Ground Green	
10	-	
11	-	
12	-	
13	Ground Red	
14	Ground Blanking	
15	-	
16	-	
17	Ground CVS output	
18	Ground CVS input	
19	CVS output	1Vpp / 75ohm
20	CVS input	1Vpp / 75ohm
21	Ground	

## 1. INTRODUCTION

11AK19 is a 90ø and 110ø chassis capable of driving 20-21", 24", 25", 28-29", 32", 33" tubes at appropriate currents.

The chassis is capable of working in both PAL and SECAM. The sound system is capable of giving 6watts

RMS output into a load of 8ohms.

One 8 page simple TELETEXT, TOPTXT and FASTEXT is provided.

The chassis is equipped with 21-pin scart connectors which can accept via scart the SVHS format from VCRs so equipped.

## 2. SMALL SIGNAL PART WITH TDA884X

The TDA8840/8842/8844 combine all small signal functions required for a colour TV receiver, except tuning.

### 2.1. Vision IF amplifier

The IF-amplifier contains 3 AC-coupled control stages with a total gain control range which is higher than 66dB.

The sensitivity of the circuit is comparable with that of modern IF-IC's. The video signal is demodulated by means of a PLL carrier regenerator. This circuit contains a frequency detector and a phase detector. The AFC output is obtained by using the VCO control voltage of the PLL and can be read via the I<sup>2</sup>C-bus. For fast search tuning systems the window of the AFC can be increased with a factor 3. The setting is realised with the AFW bit.

Depending on the type the AGC-detector operates on top-sync level (single standard versions) or on top sync and top white-level (multi standard versions). The demodulation polarity is switched via the I<sup>2</sup>C-bus. The AGC detector time-constant capacitor is connected externally. This mainly because of the flexibility of the application. The time-constant of the AGC system during positive modulation is rather long to avoid visible variations of the signal amplitude.

To improve the speed of the AGC system a circuit has been included which detects whether the AGC detector is activated every frame period. When during 3 frame periods no action is detected the speed of the system is increased. For signals without peak white information the system switches automatically to a gated black level AGC. Because a black level clamp pulse is required for this way of operation the circuit will only switch to black level AGC in the internal mode.

The circuits contain a video identification circuit which is independent of the synchronisation circuit. Therefore search tuning is possible when the display section of the receiver is used as a monitor. The ident output is supplied to the tuning system via the I<sup>2</sup>C-bus. The video ident circuit can be made less sensitive by means of the STM bit. This mode can be used during search tuning to avoid that the tuning system will stop at very weak input signals.

## **2.2. Video Switches**

The circuits have two CVBS inputs (internal and external CVBS) and Y/C input. When the Y/C input is not required the Y input can be used as third CVBS input. The selection of the various sources is made via the I<sup>2</sup>C-bus. The circuit has one CVBS output.

## **2.3. Sound Circuit**

The sound band pass and trap filters have to be connected externally. The filtered intercarrier signal is fed to a limiter circuit and is demodulated by means of a PLL demodulator. This PLL circuit tunes itself automatically to the incoming carrier signal so that no adjustment is required.

The volume is controlled via the I<sup>2</sup>C-bus. The deemphasis capacitor has to be connected externally. The non-controlled audio signal can be obtained from this pin. The FM demodulator can be muted via the I<sup>2</sup>C-bus. This function can be used to switch-off the sound during a channel change so that high output peaks are prevented. The TDA8840/8842 contain an automatic volume levelling (AVL) circuit which automatically stabilises the audio output signal to a certain level which can be set by the viewer by means of the volume control. This function prevents big audio output fluctuations due to variations of the modulation depth of the transmitter. The AVL function can be activated via the I<sup>2</sup>C-bus.

## **2.4. Synchronisation circuit**

The sync separator is preceded by a controlled amplifier which adjusts the sync pulse amplitude to a fixed level. These pulses are fed to the slicing stage which is operating at 50% of the amplitude. The separated sync pulses are fed to the first phase detector and to the coincidence detector. This coincidence detector is used to detect whether the line oscillator is synchronised and can also be used for transmitter identification. The first PLL has a very high static steepness so that the phase of the picture is independent of the line frequency. The horizontal output signal is generated by means of an oscillator which is running at twice the line frequency. Its frequency is divided by 2 to lock the first control loop to the incoming signal. The time-constant of the loop can be forced by the I<sup>2</sup>C-bus (fast or slow).

If required the IC can select the time-constant depending on the noise content of the incoming video signal.

To protect the horizontal output transistor, the horizontal drive is immediately switched off when a power-on-reset is detected. The drive signal is switched-on again when the normal switch-on procedure is followed.

Via the I<sup>2</sup>C-bus, adjustments can be made of the horizontal and vertical geometry. The vertical sawtooth generator drives the vertical output drive circuit which has a differential output current. For the EW drive a single ended current output is available. When the horizontal scan is reduced to display 4 : 3 pictures on a 16 : 9 picture tube an accurate video blanking can be switched on to obtain well defined edges on the screen.

Overvoltage conditions can be detected via the EHT tracking pin. When an overvoltage condition is detected the horizontal output drive signal will be switched-off via the slow stop procedure but it is also possible that the drive is not switched-off and that just a protection indication is given in the I<sup>2</sup>C-bus output byte. The choice is made via the input bit PRD.

## **2.5. Chroma and Luminance processing**

The circuits contain a chroma bandpass and trap circuit. The filters are realised by means of gyrator circuits and they are automatically calibrated by comparing the tuning frequency with the X-tal frequency of the decoder.

The luminance delay line and the delay for the peaking circuit are also realised by means of gyrator circuits.

The centre frequency of the chroma bandpass filter is switchable via the I<sup>2</sup>C-bus so that the performance can be optimised for "front-end" signals and external CVBS signals.

During SECAM reception the centre frequency of the chroma trap is reduced to get a better suppression of the SECAM carrier frequencies.

## **2.6. Colour Decoder**

The decoder contains an alignment-free X-tal oscillator, a killer circuit and two colour difference demodulators. The 90° phase shift for the reference signal is made internally.

The IC contains an automatic colour limiting (ACL) circuit which prevents that oversaturation occurs when signals with a high chroma-to-burst ratio are received. The ACL circuit is designed such that it only reduces the chroma signal and not the burst signal. This has the advantage that the colour sensitivity is not affected by this function.

The base-band delay line is integrated in the PAL/SECAM IC's.

The demodulated colour difference signals are internally supplied to the delay line. The matrixed signals are externally available.

The colour difference matrix switches automatically between

PAL/SECAM and NTSC, however, it is also possible to fix the matrix in the PAL standard.

Which colour standard the IC can decode depends on the external X-tals. The X-tal to be connected to pin 34 must have a frequency of 3.5 MHz (NTSC-M, PAL-M or PAL-N) and pin 35 can handle X-tals with a frequency of 4.4 and 3.5 MHz. To prevent calibration problems of the horizontal oscillator the external switching between the 2 X-tals should be carried out when the oscillator is forced to pin 35. For a reliable calibration of the horizontal oscillator it is very important that the X-tal indication bits (XA and XB) are not corrupted. For this reason the X-tal bits can be read in the output bytes so that the software can check the I<sup>2</sup>C-bus transmission.

## **2.7. RGB output circuit and black-current stabilisation**

The colour-difference signals are matrixed with the luminance signal to obtain the RGB-signals. The TDA 884X device has one linear RGB input. This RGB signal can be controlled on contrast and brightness.

The output signal has an amplitude of about 2 volts black-to-white at nominal input signals and nominal settings of the controls.

To increase the flexibility of the IC it is possible to insert OSD and/or teletext signals directly at the RGB outputs.

This insertion mode is controlled via the insertion input (pin 26 in the S-DIP 56- and pin 38 in the QFP-64 level). This blanking action at the RGB outputs has some delay which must be compensated externally.

To obtain an accurate biasing of the picture tube a "Continuous Cathode Calibration" circuit has been developed.

This function is realised by means of a 2-point black level stabilisation circuit.

When the TV receiver is switched-on, the RGB output signals are blanked and the black current loop will try to set the right picture tube bias levels. Via the AST bit a choice can be made between automatic start-up or a start-up via the m-processor.

### 3. TUNER

Either a PLL or a VST tuner is used as a tuner.

UV1316 (VHF/UHF) is used as a PLL tuner. For only PALM/N, NTSC M applications UV 1336 is used as the PLL tuner. UV 1315 (VHF/UHF) is used as a VST Tuner.

#### Channel coverage of UV1316:

BAND	OFF-AIR CHANNELS		CABLE CHANNELS	
	CHANNELS RANGE (MHz)	FREQUENCY	CHANNELS	FREQUENCY RANGE (MHz)
Low Band	E2 to C	48.25 to 82.25 (1)	S01 to S08	69.25 to 154.25
Mid Band	E5 to E12	175.25 to 224.25	S09 to S38	161.25 to 439.25
High Band	E21 to E69	471.25 to 855.25 (2)	S39 to S41	447.25 to 463.25

(1). Enough margin is available to tune down to 45.25 MHz.

(2). Enough margin is available to tune up to 863.25 MHz.

Noise	Typical	Max.	Gain	Min.	Typical	Max.
Low band	: 5dB	9dB	All channels	: 38dB	44dB	52dB
Mid band	: 5dB	9dB	Gain Taper (of-air channels)	: -	-	8dB
High band	: 6dB	9dB				

#### Channel Coverage UV1336:

BAND	CHANNELS	FREQUENCY RANGE (MHz)
Low Band	2 to D	55.25 to 139.25
Mid Band	E to PP	145.25 to 391.25
High Band	QQ to 69	397.25 to 801.25

Noise is typically 6dB for all channels. Gain is minimum 38dB and maximum 50dB for all channels.

#### Channel Coverage of UV1315:

BAND	OFF-AIR CHANNELS		CABLE CHANNELS	
	CHANNELS	FREQUENCY RANGE (MHz)	CHANNELS	FREQUENCY RANGE (MHz)
Low Band	E2 to C	48.25 to 82.25 (1)	S01 to S10	69.25 to 168.25
Mid Band	E5 to E12	175.25 to 224.25	S11 to S39	231.25 to 447.25
High Band	E21 to E69	471.25 to 855.25 (2)	S40 to S41	455.25 to 463.25

(1). Enough margin is available to tune down to 45.25 MHz.

(2). Enough margin is available to tune up to 863.25 MHz.

Noise	Typ.	Max.	Gain	Min.	Typ.	Max.
Low band	: 6dB	9dB	All Channels	38dB	44dB	50dB
Mid band	: 6dB	10dB	Gain Taper	-	-	8dB
High band	: 6dB	11dB	(off-air channels)			

### 4.VIDEO SWITCH TEA6415C

In case of three or more external sources are used, the video switch IC TEA6415C is used. The main function of this device is to switch 8 video input sources on the 6 outputs.

Each output can be switched on only one of each input. On each input an alignment of the lowest level of the signal is made (bottom of sync. top for CVBS or black level for RGB signals).

Each nominal gain between any input and output is 6.5dB. For D2MAC or Chroma signal the alignment is switched off by forcing, with an external resistor bridge, 5VDC on the input. Each input can be used as a normal input or as a MAC or Chroma input (with external resistor bridge). All the switching possibilities are changed through the BUS.

Driving 75ohm load needs an external resistor.

It is possible to have the same input connected to several outputs.

## 5. AM DEMODULATOR TDA9830

The TDA9830 is designed for AM-sound demodulation used in L and L' standard.

### Sound IF Input:

The sound IF amplifier consists of three AC-coupled differential amplifier stages each with approximately 20dB gain. At the output of each stage is a multiplier for gain controlling. The overall control range is approximately -6 to +60dB and the frequency response (-3dB) of the IF amplifier is approximately 6 to 70MHz. The steepness of gain control is approximately 10mV/dB.

### IF AGC:

The automatic gain control voltage to maintain the AM demodulator output signal at a constant level is generated by a mean level detector. The AGC-detector charges and discharges the capacitor at pin 3 controlled by the output signal of the AM-demodulator compared to an internal reference voltage. The maximum charge/discharge current is approximately 5 mA.

### AM-demodulator

The IF amplifier output signal is fed to a limiting amplifier (two stages) and to a multiplier circuit. However the limiter output signal (which is not any more AM modulated) is also fed to the multiplier, which provides AM demodulation (in phase demodulation). After lowpass filtering (fg @ 400kHz) for carrier rejection and buffering, the demodulator output signal is present at pin 6.

### Audio Switch

This circuit is an operational amplifier with three input stages and internal feedback network determining gain (0dB) and frequency response (fg @ 700kHz). Two of the input stages are connected to pin 7 and pin 9, the third input stage to an internal reference voltage. Controlled by the switching pins 10 and 12, one of the three input stages can be activated and a choice made between two different AF signals or mute state. The selected signal is present at pin 8. The decoupling capacitors at the input pins are needed, because the internally generated bias voltage for the input stages must not be influenced by the application in order to avoid DC-plop in case of switching.

### Reference Circuit:

This circuit is a band gap stabiliser in combination with a voltage regulation amplifier, which provides an internal reference voltage of about 3.6V nearly independent from supply voltage and temperature. This reference voltage is filtered by the capacitor at pin 4 in order to reduce noise. It is used as a reference to generate all important voltages and currents of the circuit. For application in 12V power supply concepts, there is an internal voltage divider in combination with a Darlington transistor in order to reduce the supply voltage for all IC function blocks to approximately 6V.

## 6. MULTISTANDARD SOUND PROCESSOR:

The MSP 34x0D is designed to perform demodulation of FM or AM-Mono TV sound. Alternatively, two-carrier FM systems according to the German or Korean terrestrial specs or the satellite specs can be processed with the MSP 34x0D. Digital demodulation and decoding of NICAM-coded TV stereo sound, is done only by the MSP 3410. The MSP 34x0D offers a powerful feature to calculate the carrier field strength which can be used for automatic standard detection (terrestrial) and search algorithms (satellite).

## 7. SOUND OUTPUT STAGE TDA2614/TDA2615/TDA2616Q

TDA2614 is used as the AF output amplifier for mono applications. It is supplied by  $\pm 12$ VDC coming from a separate winding in the SMPS transformer. An output power of 2\*6W (THD=0.5%) can be delivered into an 8ohm load.

TDA2615 is used as the AF output amplifier for stereo applications. It is supplied by  $\pm 12$ VDC coming from a separate winding in the SMPS transformer. An output power of 2\*6W (THD=0.5%) can be delivered into an 8ohm load.

TDA2616Q is used as the AF output amplifier for stereo and dolby prologic applications. It is supplied by  $\pm 16$ VDC coming from a separate winding in the SMPS transformer. An output power of 2\*12W (THD=0.5%) can be delivered into an 8ohm load.

## 8. VERTICAL OUTPUT STAGE WITH TDA8351/8356

The TDA8351/8356 vertical deflection circuit can be used in 90° and 110° deflection systems with field frequencies from 50 up to 120Hz. With its bridge configuration the deflection output can be DC coupled with few external components. Only a single supply voltage for the scan and a second supply for the flyback are needed. The TDA8356 is intended for 90° systems and the TDA8351 is intended for 110° systems.

The drive voltage is amplified by an amplifier and fed to two amplifiers, one is inverting and the other is a non inverting amplifier. The outputs (pins 7 and 4) are connected to the series connection of the vertical deflection coil and feedback resistor Rsense (R702//R703). The voltage across Rsense is fed via pin 9 to correction amplifier, to obtain a deflection current which is proportional to the drive voltage. The supply voltage for the TDA8351/8356 is 15VDC at pin 3. The supply voltage generator has a separate supply voltage of 45VDC at pin 6.

## 9. VIDEO OUTPUT AMPLIFIER TDA6108M

The TDA6108M consists of three monolithic video output amplifiers. The amplifier can be seen as an operational amplifier with negative feedback.

The advantage of negative feedback is that the amplifier characteristics do not play an important role up to certain frequencies. The internal flash diodes protect the amplifiers against flash over in the picture tube.

The only protections required at the cathode outputs are a flash resistor and a sparkgap.

The TDA6108M has an internal thermal protection circuit which gives a decrease of the slew rate at high temperatures.

Furthermore, the device needs only one power supply voltage (Vdd).

In contrast to previous types of DMOS video amplifiers, all the external resistors (Rf, Ri and Ra) are integrated, so the gain is fixed and saves 9 resistors.

Furthermore, the reference voltage is integrated, it saves a resistor divider and a decoupling capacitor. So, the replacement value of the TDA6108MQ is very high.

The TDA6108M is provided with a black current data pin. Since TDA884X is used as drive device, no adjustments are required for gain and black setting, as the TDA884X has I<sup>2</sup>C white point adjustment and black current set-up.

#### 10. SINGLE/MULTISTANDARD VIF/SIF-PLL and FM-PLL/AM DEMODULATOR TDA4470

The TDA4470 is an integrated bipolar circuit for multi-standard video / sound IF (VIF/SIF) signal processing, in TV/VCR and multimedia applications. The circuit processes all TV video IF signals with negative modulation (e.g.. B/G standard) positive modulation (e.g.. L standard) and the AM, FM/NICAM sound IF signals.

#### 11. COMBFILTER TDA9181

The TDA 9181 is an adaptive PAL/NTSC comb filter with two internal delay lines, filters, clock control, and input clamps. Video standards PAL B, G, H, I, M and N NTSC M are supported. Two CVBS input signals can be selected by means of input switch. In addition to the comb filter the circuit contains an output switch so that a selection can be made between the combed CVBS signal and an external Y/C signal. The supply voltage is 5V.

#### 12. POWER SUPPLY (SMPS)

The DC voltages required at various parts of the chassis are provided by an SMPS transformer controlled by the IC MC44604 which is designed for driving, controlling and protecting switching transistor of SMPS. The transformer produces 150/115V for FBT input,  $\pm 14V$  for audio output IC, S+2.5V and S+3.3V for microcontroller, +15V for vertical output (field scan) and +33V for tuner and some other ICs and transistors.

#### 13. MICROCONTROLLER SDA5555

The device is TV PRO tuning and control system based on the SDA 5555 TV TEXT microcontroller. It is designed for a low cost mono TV-SET with analogue picture and sound control. Nevertheless the system offers an on screen display (OSD) and IR remote control of all functions.

##### SDA5555 has the following features:

- Display of program number, channel number, TV standard, analogue values, sleep timer, parental control, and mute is done by OSD.
- Single LED for IR active, standby and on mode indication.
- 1 Control line to select external source.
- 3 Control lines for TV standard selection.
- Frequency synthesis tuning (62.5 kHz steps)
- 192 step fine tuning
- Channels corresponding to standards B/G, OIRT, L and I (I+)
- Mono sound control by analogue voltage
- System configuration with service mode

#### 14. SERIAL ACCESS CMOS 8K (1024\*8) EEPROM ST24C08

The ST24C08 is a 8Kbit electrically erasable programmable memory (EEPROM), organised as 4 blocks of 256\*8 bits. The memory is compatible with the I<sup>2</sup>C standard, two wire serial interface which uses a bi-directional data bus and serial clock. The memory carries a built-in 4 bit, unique device identification code (1010) corresponding to the I<sup>2</sup>C bus definition. This is used together with 1 chip enable input (E) so that up to 2\*8K devices may be attached to the I<sup>2</sup>C bus and selected individually.

#### 15. CLASS AB STEREO HEADPHONE DRIVER TDA1308

The TDA1308 is an integrated class AB stereo headphone driver contained in a DIP8 plastic package. The device is fabricated in a 1 mm CMOS process and has been primarily developed for portable digital audio applications.

#### 16. SAW FILTERS

Saw filter type : Model:

G1965M	: PAL-SECAM B/G MONO
G3962M	: PAL-SECAM B/G GER&NIC STEREO, PAL I' NIC STEREO, INT-1
G1984	: PAL-SECAM B/G GER&NIC STEREO INT-2
J1951M	: PAL-I MONO
J3950M	: PAL-I NIC STEREO
J1956M	: PAL-I' MONO
K2955M	: PAL-SECAM B/G-D/K MONO, PAL-SECAM B/G-D/K-I', MONO, PAL-SECAM B/G-D/K-L MONO
K2958M	: PAL-SECAM B/G-D/K (38) MONO
K2962M	: PAL-SECAM B/G-L/L' MONO
G3957M	: PAL-SECAM B/G-L/L' GER&NIC BG/L STEREO
K6256K	: PAL-SECAM B/G-D/K-I-L/L' MONO, PAL-SECAM B/G-D/K-I, L/L' GER&NIC BG/L STEREO, PAL-SECAM B/G-D/K-I-L/L' I, NICAM STEREO, PAL-SECAM B/G-D/K-I-L/L' GER&NIC I'-B/G-L, STEREO
K6259K	: PAL-SECAM B/G-D/K-I-M/N (EURO) MONO
M1963M	: PAL M/N MONO, NTSC M MONO, PAL M/N-NTSC M MONO

#### 17. BTSC STEREO/SAP/DBX-DECODER and AUDIO PROCESSOR TDA9855

The TDA9855 is a BTSC stereo/SAP/dbx decoder and audio processor. It performs all functions to transform the composite baseband signal into the appropriate audio output signals to line out and to the loudspeaker output stages.

## IC DESCRIPTIONS AND INTERNAL BLOCK DIAGRAM

- TDA8840/8842/8844
- TUNER (UV1315, UV1316, UV1336)
- TEA6415C
- TDA9830
- TDA2614/2615/2616Q
- TDA8351/8356
- TDA6108M
- TDA9181
- TDA 44608
- SDA555X
- MSP34X0D
- TDA4470
- ST24C08
- TDA1308
- G1965M
- TDA3430G
- DPL3519A
- SDA9488A
- TDA9886

### TDA8840/8842/8844:

The TDA884X is I<sup>2</sup>C-bus controlled single chip TV processor which is intended to be applied in PAL, NTSC, PAL/NTSC and multi-standard television receivers. These IC's are nearly pin compatible with the TDA837X TV processors but have a higher degree of integration because the delay line (TDA4665 function) and the SECAM decoder have been integrated. In addition to these functions some additional features have been added like "Continuous Cathode Calibration" (2-point black current loop which results in an accurate biasing of the 3 guns), adjustable luminance delay time, blue stretching and dynamic skin tone control.

#### Features:

- Vision IF circuit with PLL demodulator
- Alignment-free multi-standard FM sound demodulator (4.5 MHz to 6.5 MHz)
- Audio switch
- Flexible source selection with CVBS switch and Y(CVBS)/C input so that a comb filter can be applied
- Integrated chrominance trap circuit
- Integrated luminance delay line
- Asymmetrical peaking in the luminance channel with a noise coring function
- Black stretching of non-standard CVBS or luminance signals
- Integrated chroma band-pass filter with switchable center frequency
- Blue stretch circuit which offsets colours near white towards blue
- RGB control circuit with "Continuous Cathode Calibration" and white point adjustment
- Linear RGB inputs and fast blanking
- Possibility to insert a "blue black" option when no video signal is available
- Horizontal synchronisation with two control loops and alignment-free horizontal oscillator
- Vertical count-down circuit
- Vertical driver optimised for DC-coupled vertical output stages
- I<sup>2</sup>C-bus control of various functions
- Low dissipation (850 mW)

Functional Differences between the 8840/8842/8844:

IC VERSION (TDA)	8840	8842	8844
Multi-standard IF		X	X
Automatic Volume Limiting	X	X	
PAL Decoder	X	X	X
SECAM Decoder		X	X
NTSC Decoder		X	X
Dynamic Skin Control			X
Colour Matrix PAL/NTSC (Japan)		X	X
Colour Matrix NTSC Japan/USA			
YUV interface			X
Base-band delay line	X	X	X
Adjustable luminance delay time			X
Horizontal geometry			X
Horizontal and vertical zoom			X
Vertical scroll			X

#### PINNING

	PIN VALUE
1. Sound IF input	: 1mVrms
2. External audio input	: 500mVrms
3. IF demodulator tuned circuit 1	
4. IF demodulator tuned circuit 2	
5. IF-PLL loop filter	: Min:32-Max:60 MHz
6. IF video output	: 4.7V (Negative Modulation), 2V (Positive Modulation)
7. Serial clock input	: Low level max:1.5 V, High level min 3.5V
8. Serial data input/output	: Low level max:1.5 V, High level min 3.5V
9. Bandgap decoupling	
10. Chrominance input (S-VHS)	: 1Vpp, Max:1.4Vpp
11. External CVBS/Y input	: 1Vpp, Max:1.4Vpp
12. Main supply voltage 1	: 8V, Min:7.2V, Max:8.8V
13. Internal CVBS input	: 1Vpp, Max:1.4Vpp
14. Ground 1	

15. Audio output	: 700mVrms, Min:500mVrms, Max:900mVrms
16. SECAM PLL decoupling	
17. External CVBS input	: Vpp, Max:1.4Vpp
18. Black-current input	: Amplitude of "low" reference current : 8mA Amplitude of "high" reference current : 20mA
19. Blue output	: 2Vpp
20. Green output	: 2Vpp
21. Red output	: 2Vpp
22. Beam current limiter input/V-guard input	
23. Red input for insertion	: 0.7Vpp, Max:0.8Vpp
24. Green input for insertion	: 0.7Vpp, Max:0.8Vpp
25. Blue input for insertion	: 0.7Vpp, Max:0.8Vpp
26. RGB insertion input	: Max:0.3V
27. Luminance input	: 1.4Vpp
28. Luminance output	: 1.4Vpp
29. (B-Y) signal output	: 1.05Vpp
30. (R-Y) signal output	: 1.05Vpp
31. (B-Y) signal input	: 1.05Vpp
32. (R-Y) signal input	: 1.05Vpp
33. Subcarrier reference output	: 3.58/4.43 MHz
34. 3.58 MHz crystal connection	
35. 4.43/3.58 MHz crystal connection	
36. Loop filter phase detector	
37. 2nd supply voltage 1	: 8V, Min:7.2V, Max:8.8V
38. CVBS output	: 1Vpp, Max:1.4Vpp
39. Decoupling digital supply	: 1.8V
40. Horizontal output	: Max: 0.3V
41. Flyback input/sandcastle output	: Min:100ma, Max:300mA
42. Phase-2 filter	: 150 ms/ms
43. Phase-1 filter	: ±0.9 kHz, Max: ±1.2 kHz
44. Ground 2	
45. East-west drive output	
46. Vertical drive A output	: 0.95mA
47. Vertical drive B output	: 0.95mA
48. IF input 1	
49. IF input 2	
50. EHT/overvoltage protection input	: Min:1.2V, Max : 2.8V
51. Vertical sawtooth capacitor	: 3Vpp
52. Reference current input	: 3Vpp
53. AGC decoupling capacitor	
54. Tuner AGC output	: Max:9V (Maximum tuner AGC Output voltage), 300mV (Output saturation voltage)
55. Audio deemphasis	: 500mVrms
56. Decoupling sound demodulator	

## UV1315, UV1316, UV1336

### General description of UV1315:

The UV1315 tuner belongs to the UV 1300 family of tuners, which are designed to meet a wide range of applications. It is a combined VHF, UHF tuner suitable for CCIR systems B/G, H, L, L', I and I'. The low IF output impedance has been designed for direct drive of a wide variety of SAW filters with sufficient suppression of triple transient.

### Features of UV1315:

- Member of the UV1300 family small sized UHF/VHF tuners
- Systems CCIR:B/G, H, L, L', I and I'; OIRT:D/K
- Voltage synthesized tuning (VST)
- Off-air channels, S-cable channels and Hyperband
- Standardized mechanical dimensions and pinning
- Compact size

### PINNING

### PIN VALUE

1. Gain control voltage (AGC)	: 4.0V, Max:4.5V
2. Tuning voltage	
3. High band switch	: 5V, Min:4.75V, Max:5.5V
4. Mid band switch	: 5V, Min:4.75V, Max:5.5V
5. Low band switch	: 5V, Min:4.75V, Max:5.5V
6. Supply voltage	: 5V, Min:4.75V, Max:5.5V
7. Not connected	
8. Not connected	
9. Not connected	
10. Symmetrical IF output 1	
11. Symmetrical IF output 2	

### Bandswitching table:

	Pin 3	Pin 4	Pin 5
Low band	0V	0V	+5V
Mid band	0V	+5V	0V
High band	+5V	0V	0V



### General description of UV1316:

The UV1316 tuner belongs to the UV 1300 family of tuners, which are designed to meet a wide range of applications. It is a combined VHF, UHF tuner suitable for CCIR systems B/G, H, L, L', I and I'. The low IF output impedance has been designed for direct drive of a wide variety of SAW filters with sufficient suppression of triple transient.

### Features of UV1316:

- Member of the UV1300 family small sized UHF/VHF tuners
- Systems CCIR: B/G, H, L, L', I and I'; OIRT: D/K
- Digitally controlled (PLL) tuning via I<sup>2</sup>C-bus
- Off-air channels, S-cable channels and Hyperband
- World standardized mechanical dimensions and world standard pinning
- Compact size
- Complies to "CENELEC EN55020" and "EN55013"

### PINNING

### PIN VALUE

- |  |                             |
|--|-----------------------------|
| 1. Gain control voltage (AGC)          | : 4.0V, Max:4.5V            |
| 2. Tuning voltage                      |                             |
| 3. I <sup>2</sup> C-bus address select | : Max:5.5V                  |
| 4. I <sup>2</sup> C-bus serial clock   | : Min:-0.3V, Max:5.5V       |
| 5. I <sup>2</sup> C-bus serial data    | : Min:-0.3V, Max:5.5V       |
| 6. Not connected                       |                             |
| 7. PLL supply voltage                  | : 5.0V, Min:4.75V, Max:5.5V |
| 8. ADC input                           |                             |
| 9. Tuner supply voltage                | : 33V, Min:30V, Max:35V     |
| 10. Symmetrical IF output 1            |                             |
| 11. Symmetrical IF output 2            |                             |

### General description of UV1336:

UV1336 series is developed for reception of channels broadcast in accordance with the M, N standard. The tuning is available through built-in digitally controlled I<sup>2</sup>C bus (PLL).

### Features of UV1336:

- Global standard pinning
- Integrated Mixer-Oscillator&PLL function
- Conforms to CISPR 13, FCC and DOC (Canada) regulations
- Low power consumption
- Both Phono connector and 'F' connector are available

### PINNING

### PIN VALUE

- |                          |                             |
|--------------------------|-----------------------------|
| 1. Gain control voltage  | : 4.0V, Max:4.5V            |
| 2. Tuning voltage        |                             |
| 3. Address select        | : Max:5.5V                  |
| 4. Serial clock          | : Min:-0.3V, Max:5.5V       |
| 5. Serial data           | : Min:-0.3V, Max:5.5V       |
| 6. Not connected         |                             |
| 7. Supply voltage        | : 5.0V, Min:4.75V, Max:5.5V |
| 8. ADC input (optional)  |                             |
| 9. Tuning supply voltage | : 33V, Min:30V, Max:35V     |
| 10. Ground               |                             |
| 11. IF output            |                             |

### TEA6415C:

#### General Description:

The main function of the TEA6415C is to switch 8 video input sources on the 6 outputs. Each output can be switched to only one of the inputs whereas but any same input may be connected to several outputs. All switching possibilities are controlled through the I<sup>2</sup>C-bus.

#### Features:

- 20 MHz Bandwidth
- Cascadable with another TEA6415C (Internal address can be changed by pin 7 voltage)
- 8 inputs (CVBS, RGB, Mac, CHROMA, ...)
- 6 Outputs
- Possibility of MAC or chroma signal for each input by switching-off the clamp with an external resistor bridge
- Bus controlled
- 6.5dB gain between any input and output
- -55dB crosstalk at 5MHz
- Fully ESD protected

### PINNING

### PIN VALUE

- |          |             |                              |            |                |
|----------|-------------|------------------------------|------------|----------------|
| 1. Input | : Max       | : 2Vpp, Input Current        | : 1mA, Max | : 3mA          |
| 2. Data  | : Low level | : -0.3V Max:1.5V, High level | : 3.0V     | Max : Vcc+0.5V |
| 3. Input | : Max       | : 2Vpp, Input Current        | : 1mA, Max | : 3mA          |
| 4. Clock | : Low level | : -0.3V Max:1.5V, High level | : 3.0V     | Max : Vcc+0.5V |
| 5. Input | : Max       | : 2Vpp, Input Current        | : 1mA, Max | : 3mA          |

6. Input	: Max	: 2Vpp, Input Current	: 1mA, Max	: 3mA
7. Prog				
8. Input	: Max	: 2Vpp, Input Current	: 1mA, Max	: 3mA
9. Vcc	: 12V			
10. Input	: Max	: 2Vpp, Input Current	: 1mA, Max	: 3mA
11. Input	: Max	: 2Vpp, Input Current	: 1mA, Max	: 3mA
12. Ground				
13. Output	: 5.5Vpp,	Min : 4.5Vpp		
14. Output	: 5.5Vpp,	Min : 4.5Vpp		
15. Output	: 5.5Vpp,	Min : 4.5Vpp		
16. Output	: 5.5Vpp,	Min : 4.5Vpp		
17. Output	: 5.5Vpp,	Min : 4.5Vpp		
18. Output	: 5.5Vpp,	Min : 4.5Vpp		
19. Ground				
20. Input	: Max	: 2Vpp, Input Current	: 1mA, Max	: 3mA

### TDA9830:

#### General description:

The TDA9830, a monolithic integrated circuit, is designed for AM-sound demodulation used in L- and L'-standard. The IC provides an audio source selector and also mute switch.

#### Features:

- Adjustment free wideband synchronous AM demodulator
- Audio source-mute switch (low noise)
- Audio level according EN50049
- 5 to 8V power supply or 12 V alternative
- Low power consumption

#### PINNING

#### PIN VALUE

1. Sound IF differential input signal	: Minimum IF input signal (between pins 1 and 16):60mV Max:100mV Maximum IF input signal (between pins 1 and 16) :120mV Min :70mV
2. Not connected	
3. AGC capacitor	
4. REF voltage filtering capacitor	
5. Not connected	
6. AM demodulator output	: THD:0.8%, Max:2%; S/N:53dB, Min:47%; DC potential:2.15V, Min : 2.00V Max :2.30V
7. Input signal (from AM) to audio switch	: Max:1.2V
8. Output signal from audio switch	: 80dB, Min : 70dB
9. Input signal (from external) to audio switch	: Max:1.2V
10. Switch input select control	: Audio switching voltage to activate pin7 : Min :0V, Max :0.8V Audio switching voltage to activate pin9 : Min:1.5V, Max :Vp
11. Supply voltage	: 12V, Min:10.8V, Max:13.2V
12. Mute control	: For Mute-ON Min : 0V, Max : 0.8V For Mute-OFF Min : 1.5V, Max : Vp
13. Ground	
14. Supply voltage	: 5V, Min : 4.5V, Max : 8.8V
15. Not connected	
16. Sound IF differential input signal	: Look at pin 1

### TDA2614/TDA2615/TDA2616Q:

#### General Description of TDA2614:

The TDA2614 is a power amplifier in a 9-lead single-in-line (SIL9) plastic medium power package. It has been especially designed for mains fed applications.

#### Features:

- Requires very few external components
- No switch-on/switch-off clicks
- Input mute during switch-on and switch-off
- Low offset voltage between output and ground
- Hi-fi in accordance with IEC 268 and DIN 45500
- Short-circuit proof and thermal protected
- Mute possibility

#### PINNING

#### PIN VALUE

1. Not connected	
2. Mute input	: 300mA (For mute to activate)
3. Ground	
4. Not connected	
5. Supply voltage (negative)	: -12VDC
6. Output	: 6.9Vrms
7. Supply voltage (positive)	: +12VDC
8. Inverting input (Ground)	: 0V
9. Non-inverting input	: 700mVrms, Min : 500mVrms, Max : 900mVrms

### General Description of TDA2615:

The TDA2615 is a dual power amplifier in a 9-lead single-in-line (SIL9). It has been especially designed for mains fed applications.

#### Features:

- Requires very few external components
- No switch-on/switch-off clicks
- Input mute during switch-on and switch-off
- Low offset voltage between output and ground
- Excellent gain balance of both amplifiers
- Hi-fi in accordance with IEC 268 and DIN 45500
- Short-circuit proof and thermal protected
- Mute possibility

#### PINNING

	PIN VALUE
1. Non-inverting input 1	: 700mVrms, Min :500mVrms, Max : 900mVrms
2. Mute input	: 300mA (For mute to activate)
3. Ground	
4. Output 1	: 6.9Vrms
5. Supply voltage (negative)	: -12VDC
6. Output 2	: 6.9Vrms
7. Supply voltage (positive)	: +12VDC
8. Inverting inputs 1 and 2 (Ground)	: 0V
9. Non-inverting input 2	: 700mVrms, Min : 500mVrms, Max : 900mVrms

### General Description of TDA2616Q:

The TDA2616Q is a dual power amplifier. It is supplied in a 9-lead SIL-bent-to DIL plastic power package (SOT157). It has been especially designed for mains fed applications.

#### Features:

- Requires very few external components
- No switch-on/switch-off clicks
- Input mute during switch-on and switch-off
- Low offset voltage between output and ground
- Excellent gain balance of both amplifiers
- Hi-fi in accordance with IEC 268 and DIN 45500
- Short-circuit proof and thermal protected
- Mute possibility

#### PINNING

	PIN VALUE
1. Non-inverting input 1	: 700mVrms, Min : 500mVrms, Max : 900mVrms
2. Mute input	: 300mA (For mute to activate)
3. Ground	
4. Output 1	: 9.8Vrms
5. Supply voltage (negative)	: -16VDC
6. Output 2	: 9.8Vrms
7. Supply voltage (positive)	: +16VDC
8. Inverting inputs 1 and 2 (Ground)	: 0V
9. Non-inverting input 2	: 700mVrms, Min : 500mVrms, Max : 900mVrms

### TDA8351/8356:

#### General Description:

The TDA8356 is a power circuit for use in 90° colour deflection system for field frequencies of 50 to 120 Hz.

The circuit operates as a highly efficient class G system.

The TDA8351 is a power circuit for use in 110° colour deflection system for field frequencies of 50 to 120 Hz.

The circuit operates as a highly efficient class G system.

#### Features:

- Few external components
- Highly efficient fully DC-coupled vertical output bridge circuit
- Vertical flyback switch
- Guard circuit
- Protection against:
  - short-circuit of the output pins (7 and 4)
  - short-circuit of the output pins to Vp
- Temperature (thermal) protection
- High EMC immunity because of common mode inputs
- A guard signal in zoom mode

#### PINNING

	PIN VALUE
1. Input power-stage (positive); includes Ii(sb) signal bias	: 400mA, Min : 50mA, Max : 500mA
2. Input power-stage (negative); includes Ii(sb) signal bias	: 400mA, Min : 50mA, Max : 500mA
3. Operating supply voltage	: +15VDC
4. Output voltage B	: Max : 52V Output current : 2App (TDA8356) 3App (TDA8351)
5. Ground	
6. Input flyback supply voltage	: Min : Vp, Max : 50V
7. Output voltage A	: Max : 52V Output current : 2App (TDA8356) 3App (TDA8351)
8. Guard output voltage	: Max:5.5V (Io:100mA)
9. Input feedback voltage	: Max:52V

## TDA6108:

The TDA6108 includes three video output amplifiers in a SIL 9 MP (Single In Line 9 pins Medium Power) package SOT111BE, using high-voltage DMOS technology, and is intended to drive the three cathodes of a colour picture tube.

In contrast to previous types of DMOS video amplifiers, all external resistors ( $R_f$ ,  $R_i$  and  $R_a$ ) are integrated, so the gain is fixed and it saves 9 resistors.

To obtain maximum performance, the amplifier should be used with black-current control and mounted on the CRT panel.

### Features:

- Bandwidth: 4.0 MHz typ at 100Vpp (Measured in application set-up, with  $R_{fl}=1K\Omega$  and  $C_l=C_{tube}+C_{pcb}=10pF$ )
- Slewrate: 950V/ms
- Fixed gain of 50 times
- No external components, only the well known supply decoupling
- Very simple application with a variety of colour decoders
- Black-current measurement output for automatic black current stabilization
- Only one supply voltage needed
- Internal protection against positive appearing CRT flash-over discharges
- Protection against ESD
- Internal reference voltage
- Thermal protection
- Controllable switch-off behaviour
- Very small PCB dimensions
- Very high replacement value

### PINNING

	PIN VALUE
1. Inverting input 1	: 2Vpp
2. Inverting input 2	: 2Vpp
3. Inverting input 3	: 2Vpp
4. Ground	
5. BSC-output	: Max:7V
6. Supply voltage	: 200VDC
7. Cathode output 3	: 20mA, 100Vpp
8. Cathode output 2	: 20mA, 100Vpp
9. Cathode output 1	: 20mA, 100Vpp

## TDA 9181

### General description:

The TDA 9181 is an adaptive PAL/NTSC comb filter with two internal delay lines, filters, clock control, and input clamps. Video standards PAL B, G, H, I, M and N NTSC M are supported. Two CVBS input signals can be selected by means of input switch. In addition to the comb filter the circuit contains an output switch so that a selection can be made between the combed CVBS signal and an external Y/C signal. The supply voltage is 5V.

### Features:

- One-chip multistandard adaptive comb filter
- Cross luminance reduction
- Cross colour reduction
- No chroma trap, so sharper vertical luminance transients
- Analog discrete-time signal processing, so no quantization noise
- Anti aliasing and reconstruction filters are included
- Input switch selects between two Y/ CVBS inputs.
- Output switch selects between combed CVBS and an external Y-C source.
- Fsc as well as  $2 \times F_{sc}$  colour subcarrier signal may be applied
- Alignment free
- Few external components
- Low power

### PINNING

1. Off time circuit
2. Primary current simulation
3. Regulation and zero Crossing input
4. Soft-Start and Regulation Capacitor
5. Opto Coupler Input
6. Fault Comparator 2
7. Synchronization Input
8. Not Connected
9. Reference Voltage and Current
10. Fault Comparator 1
11. Primary Voltage Check
12. Ground
13. Output
14. Supply Voltage

## MC44604

### General description:

The MC44604 is an enhanced high performance controller that is specifically designed for off-line and DC-to-OC converter applications. In fact, the MC44604 is an evolution of the MC44603 and enables the same working in normal mode. So, it offers a really safe and reliable power management thanks particularly to its protection features (foldback, overvoltage detection, soft start accurate demagnetization detection). Its high current totem pole output is also ideally suited for driving a power MOSFET but can be used for driving a bipolar transistor in low power converters (< 150 W).

In addition to these MC44603 features, the MC44604 features a new efficient way to reduce the stand-by power, indeed, the circuit is able to detect transitions between stand-by and normal mode, and to control a patented stand-by burst mode working of the converter enabling to significantly reduce the converter consumption in stand-by mode.

### Features

- Operation up to 250 kHz Output Switching Frequency
- Inherent Feed Forward Compensation
- Latching PWM for Cycle-by-Cycle Current Limiting
- Oscillator with Precise Frequency Control
- Externally Programmable Reference Current
- Secondary or Primary Sensing
- High Current Totem Pole Output
- Overvoltage Lockout with Hysteresis
- Overvoltage Protection Facility against Open Loop
- Protection against Short Circuit on Oscillator Pin
- Fully Programmable Foldback
- Soft-Start Feature
- Accurate max Duty Cycle Setting
- Demagnetization (Zero Current Detection) Protection
- Internally Trimmed Reference
- Low Start-Up and Operating Current
- Patented Stand-by Burst Mode for low stand-by losses
- Low dV/dT for Low EMI radiations

### PINNING

1. Positive supply voltage
2. Output high state voltage
3. Output
4. Ground
5. Foldback input
6. Overvoltage Protection
7. Current sense input
8. Demagnetization detection
9. Stand-by current set
10. Oscillator frequency set
11. Soft-Start / Dmax / voltage - mode
12. Clamp error amplifier input
13. E / A Out (Error amplifier output)
14. Voltage Feedback
15. Stand-by management
16. Internal Reference current

## SDA5555

### General description:

The SDA 5555 is a single chip teletext decoder for decoding World System Teletext data as well as Video Programming System (VPS), Program Delivery Control (PDC), and Wide Screen Signalling (WSS) data used for PAL plus transmissions (line 23). The device also supports Closed caption acquisition and decoding. The device provides an integrated general-purpose, fully 8051-compatible Microcontroller with television specific hardware features. Microcontroller has been enhanced to provide powerful features such as memory banking, data pointers and additional interrupts etc. Device has an internal ROM of 128 KBytes, and an internal XRAM consists of 16 KBytes. The SDA 5555 supports a wide range of standards including PAL, NTSC and contains a digital slicer for VPS, WSS, PDC, TTX and Closed Caption, an accelerating acquisition hardware module, a display generator for Level 1.5 TTX data and powerful On screen Display capabilities based on parallel attributes, and Pixel oriented characters (DRCS). The 8-bit Microcontroller runs at 360 ns. cycle time(min.). Controller with dedicated hardware does most of the internal TTX acquisition processing, transfers data to/from external memory interface and receives/transmits data via I<sup>2</sup>C-firmware user-interface. The slicer combined with dedicated hardware stores TTX data in a VBI buffer of 1 Kilobyte. The Microcontroller firmware performs all the acquisition tasks (hamming- and parity-checks, page search and evaluation of header control bits) once per field. Additionally, the firmware can provide high-end Teletext-features like Packet-26-handling, FLOF, TOP and list-pages. The interface to user software is optimized for minimal overhead. SDA 5555 is realized in 0.25 micron technology with 2.5V supply voltage and 3.3V I/O (TTL compatible).

## Features

### General

- Feature selection via special function register
- Simultaneous reception of TTX, VPS, PDC, and WSS (line 23)
- Supply Voltage 2.5 and 3.3 V
- ROM version package P-SDIP 52, P-MQFP64
- Romless version package P-MQFP100,P-LCC84

### External Crystal and Programmable clock speed

- Single external 6MHz crystal, all necessary clocks are generated internally
- CPU clock speed selectable via special function registers.
- Normal Mode 33.33 Mhz CPU clock, Power Save mode 8.33 Mhz

### Microcontroller Features

- 8bit 8051 instruction set compatible CPU.
- 33.33-MHz internal clock (max.)
- 0.360ms (min.) instruction cycle
- Two 16-bit timers
- Watchdog timer
- Capture compare timer for infrared remote control decoding
- Pulse width modulation unit (2 channels 14 bit, 6 channels 8 bit)
- ADC (4 channels, 8 bit)
- UART

### Memory

- Non-multiplexed 8-bit data and 16 ... 20-bit address bus (ROMless Version)
- Memory banking up to 1Mbyte (Romless version)
- Up to 128 Kilobyte on Chip Program ROM
- Eight 16-bit data pointer registers (DPTR)
- 256-bytes on-chip Processor Internal RAM (IRAM)
- 128bytes extended stack memory.
- Display RAM and TXT/VPS/PDC/WSS-Acquisition-Buffer directly accessible via MOVX
- UP to 16KByte on Chip Extended RAM(XRAM) consisting of;
  - 1 Kilobyte on-chip ACQ-buffer-RAM (access via MOVX)
  - 1 Kilobyte on-chip extended-RAM (XRAM, access via MOVX) for user software
  - 3 Kilobyte Display Memory

### Display Features

- ROM Character Set Supports all East and West European Languages in single device
- Mosaic Graphic Character Set
- Parallel Display Attributes
- Single/Double Width/Height of Characters
- Variable Flash Rate
- Programmable Screen Size (25 Rows x 33...64 Columns)
- Flexible Character Matrixes (HxV) 12 x 9...16
- Up to 256 Dynamical Redefinable Characters in standard mode; 1024 Dynamical Redefinable Characters in Enhanced Mode
- CLUT with up to 4096 color combinations
- Up to 16 Colors per DRCS Character
- One out of Eight Colors for Foreground and Background Colors for 1-bit DRCS and ROM Characters
- Shadowing
- Contrast Reduction
- Pixel by Pixel Shiftable Cursor With up to 4 Different Colors
- Support of Progressive Scan and 100 Hz.
- 3 X 4Bits RGB-DACs On-Chip
- Free Programmable Pixel Clock from 10 MHz to 32MHz
- Pixel Clock Independent from CPU Clock
- Multinorm H/V-Display Synchronization in Master or Slave Mode

### Acquisition Features

- Multistandard Digital Data Slicer
- Parallel Multi-norm Slicing (TTX, VPS, WSS, CC, G+)
- Four Different Framing Codes Available
- Data Caption only Limited by available Memory
- Programmable VBI-buffer
- Full Channel Data Slicing Supported
- Fully Digital Signal Processing
- Noise Measurement and Controlled Noise Compensation
- Attenuation Measurement and Compensation
- Group Delay Measurement and Compensation
- Exact Decoding of Echo Disturbed Signals

### Ports

- One 8-bit I/O-port with open drain output and optional I<sup>2</sup>C Bus emulation support(Port0)
- Two 8-bit multifunction I/O-ports (Port1, Port3)
- One 4-bit port working as digital or analog inputs for the ADC (Port2)
- One 2-bit I/O port with secondary functions (P4.2, 4.3, 4.7)
- One 4-bit I/O-port with secondary function (P4.0, 4.1, 4.4) (Not available in P-SDIP 52)

## PINNING

1. Filter (sound standard) selection output 1	Low Level : 0V High Level : 3.3 V
2. Filter (sound standard) selection output 2	Low Level : 0V High Level : 3.3 V
3. Mod-switch selection output	Low Level : 0V High Level : 3.3 V
4. Loc.key.switch input	Low Level : 0V High Level : 3.3 V
5. Loc.key.switch input	Low Level : 0V High Level : 3.3 V
6. Loc.key.switch input	Low Level : 0V High Level : 3.3 V
7. Loc.key.switch input	Low Level : 0V High Level : 3.3 V
8. Mute output	Low Level : 0V High Level : 3.3 V
9. Digital supply voltage	2.5 V
10. Ground	
11. Digital supply voltage	3.3 V
12. CVBS input	1 Vpp
13. Analog supply voltage	2.5 V
14. Analog ground	
15. Safety input	Low Level : 0V High Level : 2.5 V
16. AV-1 status input	Low Level : 0V High Level : 2.5 V
17. AV-2 status input	Low Level : 0V High Level : 2.5 V
18. Service output	Low Level : 0V High Level : 2.5 V
19. SAND input	Low Level : 0V High Level : 2.5 V
20. ODD/EVEN output	Low Level : 0V High Level : 3.3 V
21. Cristal selection output 1	Low Level : 0V High Level : 3.3 V
22. St-by output	Low Level : 0V High Level : 3.3 V
23. Local connection	Low Level : 0V High Level : 3.3 V
24. IR-input	Low Level : 0V High Level : 3.3 V
25. Data output	Low Level : 0V High Level : 3.3 V
26. Clock signal output	Low Level : 0V High Level : 3.3 V
27. Cristal selection output 2	Low Level : 0V High Level : 3.3 V
28. IDTV serial communication output	Low Level : 0V High Level : 3.3 V
29. Ground	
30. Digital supply voltage	3.3 V
31. L-ACC output	Low Level : 0V High Level : 3.3 V
32. Write Protect output	Low Level : 0V High Level : 3.3 V
33. Reset output	Low Level : 0V High Level : 3.3 V
34. 6 MHz cristal connection 2	Low Level : 0V High Level : 3.3 V
35. 6 MHz cristal connection 1	Low Level : 0V High Level : 3.3 V
36. Analog ground	
37. Analog supply voltage	2.5 V
38. OSD-Red output	0.7 Vpp to 1.2 Vpp
39. OSD-Green output	0.7 Vpp to 1.2 Vpp
40. OSD-Blue output	0.7 Vpp to 1.2 Vpp
41. OSD-Blanking output	Low Level : 0V High Level : 3.3 V
42. Digital supply voltage	2.5 V
43. Ground	

44. Digital supply voltage	3.3 V
45. Comb Filter Standard Selection 1	Low Level : 0V High Level : 3.3 V
46. Comb Filter Standard Selection 2	Low Level : 0V High Level : 3.3 V
47. Audio Switch Transistor Selection 1	Low Level : 0V High Level : 3.3 V
48. Audio Switch Transistor Selection 2	Low Level : 0V High Level : 3.3 V
49. Audio Switch Transistor Selection 3	Low Level : 0V High Level : 3.3 V
50. Audio Switch Transistor Selection 4	Low Level : 0V High Level : 3.3 V
51. Tuning output	Low Level : 0V High Level : 3.3 V
52. Comb Filter PAL-SECAM selection output	Low Level : 0V High Level : 3.3 V

## MSP 34X0D

### General Description

The MSP 34x0D is designed to perform demodulation of FM or AM-Mono TV sound. Two kinds of MSP's are used in TV Text PRO. MSP 3400D and MSP 3410D. The MSP 3400D is fully pin and software-compatible to the MSP 3410D, but is not able to decode NICAM. It is also compatible to the MSP 3400C.

### Features

#### Demodulator and NICAM Decoder Section

The MSP 34x0D is designed to perform demodulation of FM or AM-Mono TV sound. Alternatively, two-carrier FM systems according to the German or Korean terrestrial specs or the satellite specs can be processed with the MSP 34x0D. Digital demodulation and decoding of NICAM-coded TV stereo sound, is done only by the MSP 3410.

The MSP 34x0D offers a powerful feature to calculate the carrier field strength which can be used for automatic standard detection (terrestrial) and search algorithms (satellite).

- two selectable analog inputs (TV and SAT-IF sources)
- Automatic Gain Control (AGC) for analog IF input. Input range: 0.10–3 V pp
- integrated A/D converter for sound-IF inputs
- all demodulation and filtering is performed on chip and is individually programmable
- easy realization of all digital NICAM standards (B/G, I, L, and D/K) with MSP 3410.
- FM demodulation of all terrestrial standards (incl. identification decoding)
- FM demodulation of all satellite standards
- no external filter hardware is required
- only one crystal clock (18.432 MHz) is necessary
- FM carrier level calculation for automatic search algorithms and carrier mute function
- High-deviation FM-Mono mode (max. deviation: approx.  $\pm 360$  kHz)

#### DSP Section (Audio Baseband Processing)

- flexible selection of audio sources to be processed
- two digital input and one output interface via I<sup>2</sup>S bus for external DSP processors, featuring surround sound, ADR etc.
- digital interface to process ADR (ASTRA Digital Radio) together with DRP 3510A
- performance of all deemphasis systems including adaptive Wegener Panda 1 without external components or controlling
- digitally performed FM identification decoding and dematrixing
- digital baseband processing: volume, bass, treble, 5-band equalizer, loudness, pseudostereo, and basewidth enlargement
- simple controlling of volume, bass, treble, equalizer etc.

#### Analog Section

- four selectable analog pairs of audio baseband inputs(=four SCART inputs)input level: $\leq 2$ V RMS,input impedance: $\geq 25$  KW
- one selectable analog mono input (i.e. AM sound): input level:  $\leq 2$  V RMS , input impedance:  $\geq 15$  KW
- two high-quality A/D converters, S/N-Ratio:  $\geq 85$  dB
- 20 Hz to 20 kHz bandwidth for SCART-to-SCART copy facilities
- MAIN (loudspeaker) and AUX (headphones): two pairs of fourfold oversampled D/A-converters output level per channel: max. 1.4 V RMS output resistance: max. 5 KW S/N-ratio:  $\geq 85$  dB at maximum volume max. noise voltage in mute mode:  $\leq 10$  mV (BW: 20 Hz ... 16 kHz)
- two pairs of fourfold oversampled D/A converters supplying two selectable pairs of SCART outputs. output level per channel: max. 2 V RMS , output resistance: max. 0.5 KW, S/N-Ratio:  $\geq 85$  dB (20 Hz ... 16 kHz)



## **PINNING**

1. Audio clock output (18.432 MHz)
2. Not connected
3. Not connected
4. Digital control output 1
5. Digital control output 0
6. I2C Bus address select
7. Standby (low-active)
8. Not connected
9. I2C clock
10. I2C data
11. I2S clock
12. I2S word strobe
13. I2S data output
14. I2S1 data input
15. ADR data output
16. ADR word strobe
17. ADR clock
18. Digital power supply +5 V
19. Digital ground
20. I2S2 data input
21. Not connected
22. Not connected
23. Not connected
24. Power-on reset
25. Headphone out, right
26. Headphone out, left
27. Reference ground 2 high voltage part
28. Loudspeaker out, right
29. Loudspeaker out, left
30. Not connected
31. Subwoofer output
32. Not connected
33. SCART output 2, right
34. SCART output 2, left
35. Reference ground 1 high voltage part
36. SCART output 1, right
37. SCART output 1, left
38. Volume capacitor AUX
39. Analog power supply 8.0 V
40. Volume capacitor MAIN
41. Analog ground
42. Analog reference voltage high voltage part
43. SCART input 4 in, left
44. SCART input 4 in, right
45. Analog Shield Ground 4
46. SCART input 3 in, left
47. SCART input 3 in, right
48. Analog Shield Ground 2
49. SCART input 2 in, left
50. SCART input 2 in, right
51. 32 Analog Shield Ground 1
52. SCART input 1 in, left
53. SCART input 1 in, right
54. Reference voltage IF A/D converter
55. Mono input
56. Analog ground
57. Analog power supply +5 V
58. IF input 1
59. 24 IF common
60. IF input 2 (if ANA\_IN1+ is used only, connect to AVSS with 50 pF capacitor)
61. Test pin
62. Crystal oscillator
63. Crystal oscillator
64. Test pin

## TDA 4470

### Features:

- 5 V supply voltage; low power consumption
- Aktive carrier generation by FPLL principle (frequency - phase - locked - loop) for true synchronous demodulation.
- Very linear video demodulation, good pulse response and excellent intermodulation figures.
- VCO circuit is operating on picture carrier frequency, the VCO frequency is switchable for L' - mode.
- Alignment - free AFC without external reference circuit, polarity of the AFC curve is switchable.
- VIF-AGC for negative modulated signals (peak sync detection) and for positive modulation (peak white / black level detector).
- Tuner AGC with adjustable take over point
- Alignment-free quasi parallel sound ( QPS ) mixer for FM / NICAM sound IF signals.
- Intercarrier output signal is gain controlled (necessary for digital sound processing).
- Complete alignment - free AM demodulator with gain controlled AF output.
- Separate SIF - AGC with average detection.
- Two independent SIF inputs.
- Parallel operation of the AM demodulator and QPS mixer (for NICAM - L stereo sound)
- Package and relevant pinning is compatible with the single standard version TDA4472, simplifies the design of an universal IF module

### PINNING

1. SIF1 input (symmetrical)
2. SIF1 input (symmetrical)
3. Input selector switch
4. Ground
5. SIF - AGC (time constant)
6. VIF input (symmetrical)
7. VIF input (symmetrical)
8. VIF AGC (time constant)
9. Ground
10. Take over point, tuner AGC
11. Tuner AGC output current
12. Video output
13. Standart switch
14. L' switch
15. Black level capacitor
16. Ground
17. Internal reference voltage
18. Loop filter
19. AFC switch
20. VCO circuit
21. VCO circuit
22. AFC output
23. Supply voltage
24. Intercarrier output
25. AF output - AM sound
26. Offset compensation
27. SIF 2 input (symmetrical)
28. SIF 2 input (symmetrical)

## S-24C08A

### General description:

The S-24C08A is a series of 2-wire , low power 8Kbit EEPROM with a wide operating range. It is organized as 1K-word X 8-bit. It is capable of page write and sequential read.

### Features:

- Power consumption
  - standby : 1.0 uA Max. (Vcc = 5.5 V)
  - Operating : 0.8 mA Max. (Vcc = 5.5 V f=400kHz)
  - 0.4 mA Max. (Vcc = 4.5 V f=100kHz)
- Operating voltage range
  - Write : 2.5 V to 5.5 V
  - Read : 1.8 V to 5.5 V
- Page write
  - 16 bytes
- Sequential read capable
- Endurance : 100.000 cycles / word
- Data retention : 10 years
- Write Protection
- 8 K bit

## PIN FUNCTIONS

Pin No	Name	Function
1	AO	Connected to ground
2	A1	Connected to ground
3	A2	Connected to ground
4	A3	Connected to ground
5	SDA	Serial data input/output
6	SCL	Serial clock input
7	WP	Write Protection Pin - Connected to Vcc : Protection valid - Connected to Ground : Protection invalid
8	Vcc	Power Supply

## TDA1308:

### Features:

- Wide temperature range
- No switch ON/OFF clicks
- Excellent power supply ripple rejection
- Low power consumption
- Short-circuit resistant
- High performance
  - high signal-to-noise ratio
  - high slew rate
  - low distortion
- Large output voltage swing

### PINNING

1. Output A (Voltage swing)
2. Inverting input A
3. Non-inverting input A
4. Ground
5. Non-inverting input B
6. Inverting input B
7. Output B (Voltage swing)
8. Positive supply

### PIN VALUE

- : Min : 0.75V, Max : 4.25V
- : Vo(clip) : Min : 1400mVrms
- : 2.5V
- : 0V
- : 2.5V
- : Vo(clip) : Min : 1400mVrms
- : Min : 0.75V, Max : 4.25V

## G1965M:

### Features:

- TV IF filter with Nyquist slope and sound shelf at typ. 20.4dB
- High colour carrier level at typ. 1.0dB
- Constant group delay
- Insertion attenuation typ. 15.0dB

### PINNING

1. Input
2. Input-ground
3. Chip carrier-ground

## MSP 3430G

### General Description

The MSP3430G is the BTSC version of the MSP34X0G series Multi Standard Sound Processors.

### Features

- Standard Selection with single I 2 C transmission
- Automatic Standard Detection of terrestrial TV standards
- Automatic Sound Selection (mono/stereo/bilingual), new registers MODUS, STATUS
- Two selectable sound IF (SIF) inputs
- Automatic Carrier Mute function
- Interrupt output programmable (indicating status change)
- Loudspeaker / Headphone channel with volume, balance, bass, treble, loudness
- AVC: Automatic Volume Correction
- Subwoofer output with programmable low-pass and complementary high-pass filter
- 5-band graphic equalizer for loudspeaker channel
- Spatial effect for loudspeaker channel
- Four Stereo SCART (line) inputs, one Mono input; two Stereo SCART outputs
- Complete SCART in/out switching matrix
- Two I 2 S inputs; one I 2 S output
- Dolby Pro Logic with DPL 351xA coprocessor
- Demodulation of the BTSC multiplex signal and the SAP channel
- Alignment free digital DBX noise reduction for BTSC Stereo and SAP
- BTSC stereo separation (MSP 3420/40G also EIA-J) significantly better than spec.
- SAP and stereo detection for BTSC system
- Demodulation of the FM-Radio multiplex signal

## PINNING

1. Audio clock output (18.432 MHz)
2. Not connected
3. Not connected
4. D\_CTR\_I/O\_1
5. D\_CTR\_I/O\_0
6. I2C Bus address select
7. Stand-by (low-active)
8. Not connected
9. I2C clock
10. I2C data
11. I2S clock
12. I2S word strobe
13. I2S data output
14. I2S1 data input
15. ADR data output
16. ADR word strobe
17. ADR clock
18. Digital power supply 5 V
19. Digital ground
20. I2 S2-data input
21. Not connected
22. Not connected
23. Not connected
24. Power-on-reset
25. Headphone out, right
26. Headphone out, left
27. Reference ground 2
28. Loudspeaker out, right
29. Loudspeaker out, left
30. Not connected
31. Subwoofer output
32. Not connected
33. SCART output 2, right
34. SCART output 2, left
35. Reference ground 1
36. SCART output 1, right
37. SCART output 1, left
38. Volume capacitor AUX
39. Analog power supply 8 V
40. Volume capacitor MAIN
41. Analog ground
42. Analog reference voltage
43. SCART 4 input, left
44. SCART 4 input, right
45. Analog Shield Ground 4
46. SCART 3 input, left
47. SCART 3 input, right
48. Analog Shield Ground 2
49. SCART 2 input, left
50. SCART 2 input, right
51. Analog Shield Ground 1
52. SCART 1 input, left
53. SCART 1 input, right
54. Reference voltage IF A/D converter
55. Mono input
56. Analog ground
57. Analog power supply 5 V
58. IF input 1
59. IF common (can be left vacant, only if IF input 1 is also not in use)
60. IF input 2 (can be left vacant, only if IF input 1 is also not in use)
61. Test pin
62. Crystal oscillator
63. Crystal oscillator
64. Test pin

## DPL 3519A DOLBY SURROUND PROLOGIC IC.

The DPL 3519A processor is designed to decode Dolby encoded surround sound. The IC integrates the complete Dolby Surround Pro Logic decoding on chip without any necessary external circuitry. The DPL 3519A is designed as a coprocessor to the MSP family. Together with the MSP, a TV set with up to six outputs (L,R,C,SUB,SL,SR) can be developed together with headphones and several line outputs.

### Features:

- Full Dolby Surround Pro Logic Adaptive Matrix
- Pseudo-surround mode for signals not encoded in Dolby Surround
- PANORAMA sound mode (3-D Surround sound via 2 loudspeakers)
- Noise sequencer
- Automatic input balance control
- 7 kHz low-pass filter
- 100 Hz low-pass filter for subwoofer
- Modified Dolby B-type NR decoder
- 30 ms surround delay according to table created by Dolby Laboratories (1 ms steps)
- 2 I<sup>2</sup>S input channels (e.g. MSP and DRPA)
- 2 I<sup>2</sup>S output channels, freely programmable with sound channels L/R (resp. L \_ C/R \_ C), C/S, Sub or I<sup>2</sup>S input
- Mode control: normal/phantom/wide/three channel/center off/panorama sound/stereo bypass
- Surround matrix mode control: adaptive/passive/effect
- Additional surround basewidth effect
- Reverberation of surround signals
- 2 digital input/output pins
- 1 digital input pin
- Master volume control in dB units
- Level Trim for L, C, R, S in dB units, \_ 12 dB
- Identical treble/bass/loudness function for L, C, R, S
- Separate volume control for two surround outputs
- Additional line output for HIFI receiver connection (SCART output). Volume for this output is in dB units.
- 3 pairs of D/A converters
- Scart switches

### PINNING

1.	NC	Not connected
2.	NC	Not connected
3.	NC	Not connected
4.	I <sup>2</sup> S_DA_IN1	I <sup>2</sup> S1 data input
5.	I <sup>2</sup> S_DA_OUT1	I <sup>2</sup> S1 data output
6.	I <sup>2</sup> S_WS	I <sup>2</sup> S wordstrobe
7.	I <sup>2</sup> S_CL	I <sup>2</sup> S clock
8.	I <sup>2</sup> C_DA	I <sup>2</sup> C data
9.	I <sup>2</sup> C_CL	I <sup>2</sup> C clock
10.	NC	Not connected
11.	STANDBYQ	Standby (low-active)
12.	ADR_SEL	I <sup>2</sup> C-Bus address select
13.	D_CTR_IO0	Digital control IO 0
14.	D_CTR_IO1	Digital control IO 1
15.	NC	Not connected
16.	NC	Not connected
17.	NC	Not connected
18.	AUD_CL_OUT	Audio clock output
19.	D_CTR_IN	Digital control input
20.	XTAL_OUT	Crystal oscillator
21.	XTAL_IN	Crystal oscillator
22.	TESTEN	Test pin
23.	NC	Not connected
24.	NC	Not connected
25.	NC	Not connected
26.	AVSUP	Analog power supply +5 V
27.	AVSS	Analog ground
28.	MONO_IN	Mono input
29.	VREFTOP	Reference voltage
30.	SC1_IN_R	Scart input 1 in, right
31.	SC1_IN_L	Scart input 1 in, left
32.	ASG1	Analog Shield Ground 1
33.	SC2_IN_R	Scart input 2 in, right
34.	SC2_IN_L	Scart input 2 in, left
35.	ASG2	Analog Shield Ground 2
36.	SC3_IN_R	Scart input 3 in, right
37.	SC3_IN_L	Scart input 3 in, left
38.	ASG4	Analog Shield Ground 4
39.	NC	Not connected
40.	NC	Not connected
41.	NC	Not connected

42.	AGNDC	Analog reference voltage high voltage part
43.	AHVSS	Analog ground
44.	CAPL_C1	Volume capacitor Channel1
45.	AHVSUP	Analog power supply 8.0 V
46.	CAPL_C2	Volume capacitor Channel2
47.	SC1_OUT_L	Scart output 1, left
48.	SC1_OUT_R	Scart output 1, right
49.	VREF1	Reference ground 1 high voltage part
50.	SC2_OUT_L	Scart output 2, left
51.	SC2_OUT_R	Scart output 2, right
52.	ASG3	Analog Shield Ground 3
53.	NC	Not connected
54.	NC	Not connected
55.	NC	Not connected
56.	DACC1_L	Analog output Channel 1, left
57.	DACC1_R	Analog output Channel 1, right
58.	VREF2	Reference ground 2 high voltage part
59.	DACC2_L	Analog output Channel 2, left
60.	DACC2_R	Analog output Channel 2, right
61.	RESETQ	Power-on-reset
62.	NC	Not connected
63.	NC	Not connected
64.	I <sup>2</sup> S_DA_OUT2	I <sup>2</sup> S2-data output
65.	I <sup>2</sup> S_DA_IN2	I <sup>2</sup> S2-data input
66.	DVSS	Digital ground
67.	DVSUP	Digital power supply +5 V
68.	NC	Not connected

### SDA 9488X High-end Picture-In-Picture (PIP) IC

#### Features

- Single chip solution:
  - AD-conversion for CVBS or Y/C or YUV, multistandard color decoding, PLL for synchronization of inset channel, decimation filtering, embedded memory, RGB-matrix, DA-conversion, RGB/YUV switch, data-slicer and clock generation integrated on chip
- Analog inputs:
  - 3x CVBS or 1x CVBS and 1x Y/C or 1xYUV alternatively
  - Clamping of each input
  - All ADCs with 8 bit amplitude resolution
  - Automatic Gain Control (AGC) for Y and CVBS
- Inset Synchronization:
  - Multiple time constants for reliable synchronization
  - Automatic recognition of 625 lines / 525 lines standard
- Color Decoder:
  - PAL-B/G, PAL-M, PAL-N(Argentina), PAL60, NTSC-M, NTSC4.4 and SECAM
  - Adjustable Chroma Saturation
  - Hue Control for NTSC
  - Automatic Chroma Control (-24 dB ... +6 dB)
  - Automatic recognition of chroma standards: different search strategies selectable
  - Single crystal for all standards
  - IF-characteristic compensation filter
- Display Features:
  - 16:9 compatibility
  - Display on VGA and SVGA screen (f H limited to 40kHz)
  - Coarse positioning at 4 corners of the parent picture
- Output signal processing:
  - 7 Bit DAC
  - RGB or YUV switch: connection of an external source without PIP processing
  - Analog outputs: Y, +(B-Y), +(R-Y), or Y, -(B-Y), -(R-Y) or RGB.
  - Three RGB matrices available: NTSC(Japan), NTSC(USA) or EBU
  - Slicing of closed-caption or WSS data ('violence blocking capability')
- I<sup>2</sup>C-Bus control (400 kHz)
- High stability clock generation
- SDA 9388X / SDA 9389X pinout compatibility
- 3.3V supply voltage (5V input capable)

#### PINNING

1.	XIN	crystal oscillator (input) or crystal clock (from another IC)
2.	XQ	crystal oscillator (output)
3.	HSP	horizontal sync for parent channel
4.	VSP	vertical sync for parent channel
5.	SDA	I <sup>2</sup> C-bus data
6.	SCL	I <sup>2</sup> C-bus clock
7.	VDD	digital supply voltage
8.	VSS	digital ground
9.	I <sup>2</sup> C	I <sup>2</sup> C Address

10.	INT	interrupt
11.	IN1	V/R Input for external YUV/RGB source
12.	IN2	Y/G Input for external YUV/RGB source
13.	IN3	U/B Input for external YUV/RGB source
14.	FSW	fast switch input for YUV/RGB switch
15.	SEL	fast blanking output for PIP
16.	OUT3	analog output: chrominance signal $+(B-Y)$ or $-(B-Y)$ or B
17.	OUT2	analog output: luminance signal Y or G
18.	OUT1	analog output: chrominance signal $+(R-Y)$ or $-(R-Y)$ or R
19.	VDDA2	analog supply voltage (V DDA ) for DAC
20.	VSSA2	analog ground (V SS ) for DAC
21.	VREFH	reference voltage for ADC and DAC (high)
22.	VDDA1	analog supply voltage (V DDA ) for ADC
23.	VSSA1	analog ground (Vss) for ADC
24.	CVBS3	CVBS Input 3 or C (selectable via I <sup>2</sup> C-bus)
25.	VREFL	reference voltage for ADC (low)
26.	CVBS2	CVBS Input 2 or Y (selectable via I <sup>2</sup> C-bus)
27.	VREFM	reference voltage for ADC (medium)
28.	CVBS1	CVBS Input 1 (selectable via I <sup>2</sup> C-bus)

### TDA9886

#### I<sup>2</sup>C-bus controlled single/multistandard alignment-free IF-PLL

The TDA9886 is an alignment-free multistandard (PAL, SECAM and NTSC) vision IF signal PLL demodulator for positive and negative modulation.

#### Features

- 5 V supply voltage
- Gain controlled wide-band Vision Intermediate Frequency (VIF) amplifier (AC-coupled)
- Multistandard demodulation with active carrier regeneration
- Gated phase detector for L/L accent standard
- Fully integrated VIF Voltage Controlled Oscillator (VCO), alignment-free; frequencies switchable for all negative and positive modulated standards via I<sup>2</sup>C-bus
- Digital acquisition help, VIF frequencies of 33.4, 33.9, 38.0, 38.9, 45.75 and 58.75 MHz
- 4 MHz reference frequency input [signal from PLL tuning system] or operating as crystal oscillator
- VIF Automatic Gain Control (AGC) detector for gain control,
- Fully digital Automatic Frequency Control (AFC) detector with 4-bit digital-to-analog converter;
- Alignment-free selective FM-PLL demodulator with high linearity and low noise
- I<sup>2</sup>C-bus control for all functions

#### PINNING

1.	VIF1	VIF differential input 1
2.	VIF2	VIF differential input 2
3.	OP1	Output 1 (open-collector)
4.	FMPLL	FM-PLL for loop filter
5.	DEEM	De-emphasis output for capacitor
6.	AFD	AF decoupling input for capacitor
7.	DGND	Digital ground
8.	AUD	Audio output
9.	TOP	Tuner AGC TakeOver Point (TOP)
10.	SDA	I <sup>2</sup> C-bus data input/output
11.	SCL	I <sup>2</sup> C-bus clock input
12.	SIOMAD	Sound intercarrier output and MAD select
13.	NC	Not connected
14.	TAGC	Tuner AGC output
15.	REF	4 MHz crystal or reference input
16.	VAGC	VIF-AGC for capacitor
17.	CVBS	Video output
18.	AGND	Analog ground
19.	VPLL	VIF-PLL for loop filter
20.	VP	Supply voltage (+5 V)
21.	AFC	AFC output
22.	OP2	Output 2 (open-collector)
23.	SIF1	SIF differential input 1
24.	SIF2	SIF differential input 2

# AK19PRO CHASSIS MANUAL ADJUSTMENTS PROCEDURE

In order to enter the service menu, first enter the installation menu and then press the digits 4, 7, 2 and 5 respectively.

For ADJUST settings:

Select **Adjust** using  $\nabla$  or  $\triangle$  button and press  $\triangleright$  or  $\triangleleft$  button to enter it. To select different adjust parameters, use  $\nabla$  or  $\triangle$  button. To change the selected parameter, use  $\triangleright$  or  $\triangleleft$  button.

## WHITE BALANCE ADJUSTMENT:

The following three parameters are used to make white balance adjustment. To do this, use a Colour Analyser. Using white point RED, white point GREEN and white point BLUE parameters, insert the + sign in the square which is in the middle of the screen.

**ADJUST 00** = White Point RED

**ADJUST 01** = White Point GREEN

**ADJUST 02** = White Point BLUE

## AGC ADJUSTMENT:

In order to do AGC adjustment, enter a 60dBmV RF signal level from channel C-12.

Connect a digital voltmeter to pin 1 of the tuner. Change the AGC parameter until you see 3.70VDC on voltmeter display. Check that picture is normal at 90dBmV signal level.

**ADJUST 03** = AGC

## IF-PLL NEGATIVE ADJUSTMENT (Only with PLL tuner):

Connect 38.9 MHz test pattern for PAL B/G, PAL-SECAM B/G, 39.5 MHz test pattern for PAL I or 45.75 MHz test pattern for PAL M/N, NTSC M model to Z401 SAW filter input terminals. Change the IF-PLL Negative parameter until you see IN, DOWN below. If you cannot catch IN, DOWN position this way, using a screwdriver rotate the VIF-COIL LT401 left or right until you see IN, DOWN.

**ADJUST 04** = IF-PLL Negative

## IF-PLL POSITIVE ADJUSTMENT (Only with PLL tuner):

Connect 33.9 MHz test pattern for SECAM L' model to Z401 SAW filter input terminals. Change the IF-PLL Positive parameter until you see IN, DOWN below. If you cannot catch IN, DOWN position this way, using a screwdriver rotate the VIF-COIL LT401 left or right until you see IN, DOWN.

**ADJUST 05** = IF-PLL Positive

## LUMINANCE DELAY ADJUSTMENT (with only TDA 8844 video processor):

**ADJUST 06** = Y-Delay PAL

Enter a PAL B/G colour and black-white bar test pattern via RF. Adjust Y-Delay PAL till the colour transients on the colour bar of the pattern become as sharper and colours between transients do not mix with each other as possible.

**Note:** If the SAW filter is one of the G1965M, J1951M, J3950M, K2958M, K2962M, G3957M, K6256K, K6259K or M1963M, there is constant group delay distortion, so for an equal delay of the luminance and chrominance signal the delay must be set at a value of 160nS. This means the adjustment must be set to the maximum value.

**ADJUST 07** = Y-Delay SECAM

Enter a SECAM B/G colour and black-white bar test pattern via RF. Adjust Y-Delay SECAM till the colour transients on the colour bar of the pattern become as sharper and colours between transients do not mix with each other as possible.

**Note:** If the SAW filter is one of the G1965M, K2958M, K2962M, G3957M, K6256K or K6259K, there is constant group delay distortion, so for an equal delay of the luminance and chrominance signal the delay must be set at a value of 160nS. This means the adjustment must be set to the maximum value.

**ADJUST 08** = Y-Delay NTSC

Enter an NTSC colour and black-white bar test pattern via RF. Adjust Y-Delay NTSC till the colour transients on the colour bar of the pattern become as sharper and colours between transients do not mix with each other as possible.

**Note:** If the SAW filter is M1963M, there is constant group delay distortion, so for an equal delay of the luminance and chrominance signal the delay must be set at a value of 160nS. This means the adjustment must be set to the maximum value.

**ADJUST 09** = Y-Delay Other

In case of other colour systems, enter this system with colour and black-white bar test pattern via RF. Adjust Y-Delay Other till the colour transients on the colour bar of the pattern become as sharper and colours between transients do not mix with each other as possible. Normally for an equal delay of the luminance and chrominance signal the delay must be set at a value of 160nS. This means the adjustment must be set to the maximum value.



**VERTICAL ZOOM ADJUSTMENT (only for 110ø picture tubes):**

**ADJUST 10 (4:3 PICTURE MODE), ADJUST 21 (16:9 PICTURE MODE), ADJUST 32 (CINEMA PICTURE MODE), ADJUST 43 (SUBTITLE PICTURE MODE), ADJUST 54 (SUPER ZOOM PICTURE MODE) = Vertical Zoom**

Enter a PAL B/G circle test pattern via RF. Change vertical zoom till you see the upper and lower limit of the circle as close to the upper and lower limit of the picture tube as possible.

**VERTICAL SCROLL ADJUSTMENT (only for 110ø picture tubes):**

**ADJUST 11 (4:3 PICTURE MODE), ADJUST 22 (16:9 PICTURE MODE), ADJUST 33 (CINEMA PICTURE MODE), ADJUST 44 (SUBTITLE PICTURE MODE), ADJUST 55 (SUPER ZOOM PICTURE MODE) = Vertical Scroll**

Enter a PAL B/G circle test pattern via RF. Change vertical scroll till you see the circle exactly in the middle of the screen.

**4:3 HORIZONTAL SHIFT ADJUSTMENT:**

**ADJUST 12 (4:3 PICTURE MODE), ADJUST 23 (16:9 PICTURE MODE), ADJUST 34 (CINEMA PICTURE MODE), ADJUST 45 (SUBTITLE PICTURE MODE), ADJUST 56 (SUPER ZOOM PICTURE MODE) = Horizontal Shift**

Enter a RED PURITY test pattern via RF. Change horizontal shift till the picture is horizontally centred. Check whether this adjustment is correct after completing Service Mode Adjustment.

**VERTICAL SLOPE ADJUSTMENT:**

**ADJUST 13 (4:3 PICTURE MODE), ADJUST 24 (16:9 PICTURE MODE), ADJUST 35 (CINEMA PICTURE MODE), ADJUST 46 (SUBTITLE PICTURE MODE), ADJUST 57 (SUPER ZOOM PICTURE MODE) = Vertical Slope**

Enter a CROSS-HATCH B/G test pattern via RF. Change vertical slope till the size of squares on both the upper and lower part of test pattern become equal to the squares laying on the vertical centre of the test pattern. Check and readjust VERTICAL SLOPE item if the adjustment becomes improper after some other geometric adjustments are done.

**VERTICAL AMPLITUDE ADJUSTMENT:**

**ADJUST 14 (4:3 PICTURE MODE), ADJUST 25 (16:9 PICTURE MODE), ADJUST 36 (CINEMA PICTURE MODE), ADJUST 47 (SUBTITLE PICTURE MODE), ADJUST 58 (SUPER ZOOM PICTURE MODE) = Vertical Amplitude**

Enter a PAL B/G test pattern via RF. Change vertical slope till horizontal black lines on both the upper and lower part of the test pattern become very close to the upper and lower horizontal sides of picture tube and nearly about to disappear. Check and readjust VERTICAL AMPLITUDE item if the adjustment becomes improper after some other geometric adjustments are done.

**S-CORRECTION ADJUSTMENT:**

**ADJUST 15 (4:3 PICTURE MODE), ADJUST 26 (16:9 PICTURE MODE), ADJUST 37 (CINEMA PICTURE MODE), ADJUST 48 (SUBTITLE PICTURE MODE), ADJUST 59 (SUPER ZOOM PICTURE MODE) = S-Correction**

Enter a PAL B/G circle test pattern via RF. Change S-correction till the middle part of the circle is as round as possible.

**VERTICAL SHIFT ADJUSTMENT:**

**ADJUST 16 (4:3 PICTURE MODE), ADJUST 27 (16:9 PICTURE MODE), ADJUST 38 (CINEMA PICTURE MODE), ADJUST 49 (SUBTITLE PICTURE MODE), ADJUST 60 (SUPER ZOOM PICTURE MODE) = Vertical Shift**

Enter a PAL B/G test pattern via RF. Change Vertical Shift till the test pattern is vertically centred, i.e. horizontal line at the centre pattern is in equal distance both to upper and lower side of the picture tube. Check and readjust Vertical Shift item if the adjustment becomes improper after some other geometric adjustments are done.

**EW WIDTH ADJUSTMENT (only for 110ø picture tubes):**

**ADJUST 17 (4:3 PICTURE MODE), ADJUST 28 (16:9 PICTURE MODE), ADJUST 39 (CINEMA PICTURE MODE), ADJUST 50 (SUBTITLE PICTURE MODE), ADJUST 61 (SUPER ZOOM PICTURE MODE) = EW Width**

Enter a PAL B/G test pattern via RF. Change EW Width till the vertical black and white bars on both left and right side of the pattern exactly disappear.

**EW PARABOLA WIDTH ADJUSTMENT (only for 110ø picture tubes):**

**ADJUST 18 (4:3 PICTURE MODE), ADJUST 29 (16:9 PICTURE MODE), ADJUST 40 (CINEMA PICTURE MODE), ADJUST 51 (SUBTITLE PICTURE MODE), ADJUST 62 (SUPER ZOOM PICTURE MODE) = EW Parabola Width**

Enter a PAL B/G test pattern via RF. Change EW Parabola Width till vertical lines close to the both sides of the picture frame become parallel to vertical sides of picture tube. Check and readjust EW Parabola Width item if the adjustment becomes improper after some other geometric adjustments are done.

**EW CORNER PARABOLA ADJUSTMENT (only for 110ø picture tubes):**

**ADJUST 19 (4:3 PICTURE MODE), ADJUST 30 (16:9 PICTURE MODE), ADJUST 41 (CINEMA PICTURE MODE), ADJUST 52 (SUBTITLE PICTURE MODE), ADJUST 63 (SUPER ZOOM PICTURE MODE) = EW Corner Parabola**

Enter a PAL B/G test pattern via RF. Change EW Corner Parabola till vertical lines at the corners of both sides of picture frame become vertical and parallel to vertical corner sides of picture tube. Check and readjust EW Corner Parabola item if the adjustment becomes improper after some other geometric adjustments are done.

**EW TRAPEZIUM ADJUSTMENT (only for 110ø picture tubes):**

**ADJUST 20 (4:3 PICTURE MODE), ADJUST 31 (16:9 PICTURE MODE), ADJUST 42 (CINEMA PICTURE MODE), ADJUST 53 (SUBTITLE PICTURE MODE), ADJUST 64 (SUPER ZOOM PICTURE MODE) = EW Trapezium**

Enter a PAL B/G test pattern via RF. Change EW Trapezium till vertical lines, especially lines at the sides of the picture frame become parallel to the both sides of picture tube as close as possible. Check and readjust EW Trapezium item if the adjustment becomes improper after some other geometric adjustments are done.

**ADJUST 65 OSD position**

Determines the horizontal position of the OSD's.

### For OPTION settings:

Select **OPTION** using ▽ or △ button and press ▷ or ◁ button to enter it. To select different option bytes, use ▽ or △ button. Usine ◁ or ▷ button select the bit you want to set and then set it pressing 0 or 1 button.

#### Option 0. Video Processor Crystal indication

B7:	Ina	=	x
B6:	Inb	=	x
B5:	Inc	=	x
B4:	Akb	=	0 ((0x 02) Hue B6 (Black current stabilisation))
B3:	Foa	=	x
B2:	Fob	=	x
B1:	Xa	=	note1 (Crystal indication)
B0:	Xb	=	note1 (Crystal indication)

#### note 1:

Xa,Xb

0,1	:	Pal M, Pal N, Ntsc M Pin 34 : 3.58 (1, 2 or 3 crystals) Pin 35 : No crystal
1,0	:	Pal BG, Pal DK, Pal I/I+, Secam BG, Secam DK, Secam L/L', Secam K1 Pin 34 : No crystal Pin 35 : 4.43 (1 crystal)
1,1	:	Pal BG, Pal DK, Pal I/I+, Secam BG, Secam DK, Secam L/L', Secam K1, Pal M, Pal N, Ntsc M Pin 34 : 3.58 (1, 2 or 3 crystals) Pin 35 : 4.43 (1 crystal)

#### Option 01 (0x01) Video Processor Decoder Mode Register

B7:	Forf	=	1 (Forced fiel frequency auto (50Hz when line not synchronized))
B6:	Fors	=	1 (Forced fiel frequency auto (50Hz when line not synchronized))
B5:	DI	=	x
B4:	Stb	=	x (Stand-by)
B3:	Poc	=	x
B2:	Cm2	=	x
B1:	Cm1	=	x
B0:	Cm0	=	x

#### Option 02 (0x18) Video Processor Blanking Control

B7:	Oso	=	0 (Switch-off in vertical overscan)
B6:	Vsd	=	0 (Vertical scan disable)
B5:	Cb	=	0 (Chroma bandpass center frequency)
B4:	Bls	=	0 (Blue Stretch)
B3:	Bks	=	0 (Black Stretch)
B2:	le1	=	x
B1:	Afw	=	x
B0:	Bb	=	0 (Blue back when no video signal is identified)

#### Option 03 (0x 19) Video Processor Cathode Drive Level

B7:	Hob	=	x note 1
B6:	Bps	=	0 (Bypass of chroma base-band delay line)
B5:	Acl	=	x
B4:	Cmb	=	note 2 (Enable external comb filter)
B3:	Ast	=	x
B2:	CI2	=	1 (Cathode drive level) +57%
B1:	CI1	=	0 (Cathode drive level) +57%
B0:	CI0	=	0 (Cathode drive level) +57%

#### note 1:

- 0 = Pal+ helper output blanking disabled
- 1 = Pal+ helper output blanking enabled

#### note 2:

- 0 = Comb filter disabled
- 1 = Comb filter enabled

#### Option 04

B7:	lfs	=	x
B6:	Mod	=	x
B5:	Vsw	=	x
B4:	Sm	=	x
B3:	Ds	=	0 ((0x1A) LuminanceDelay (Dynamic skin control on/off ))
B2:	Dsa	=	0 ((0x1A) LuminanceDelay (Dynamic skin control angle))
B1:	Fav	=	0 ((0x14) (VolumeControl B6 (Fixed Audio Volume )))
B0:	Lfa	=	x

**Option 05 CTI Available**

B7 : Hbl = 0 ((0x02) Hue (RGB blanking mode (TDA8844/47/54/57)))  
 B6 : Lbm = 0 ((0x09) Vertical Amplitude (Long blanking mode))  
 B5 : Vim = x  
 B4 : Gai = note 1 ((0x03) Horizontal Shift B6 (Gain of luminance channel))  
 B3 : Nci = x  
 B2 : Strm = x  
 B1 : Vid = x  
 B0 : ... = x

**note 1:**

0 = CTI disabled  
 1 = CTI available

**Option 06**

B7 : Hco = x  
 B6 : Evg = 1((0x0A) S-Correction ( Enable vertical guard (RGB blanking)))  
 B5 : Sbl = 1((0x0B) Vertical Shift B7 (Service Blanking))  
 B4 : Prd = x  
 B3 : Mat = note 1 ((0x 0E White Point Blue B7(PAL-SECAM/NTSC matrix(TDA8841/42/44/54)))  
 B2 : Rbl = x  
 B1 : Cor = x  
 B0 : ... = x

**Option 07 Country Value, PLL\_VST, PIP Zoom Mode, PIP Position**

B7 : C3 = note 1  
 B6 : C2 = note 1  
 B5 : C1 = note 1  
 B4 : C0 = note 1  
 B3 : PV = note 2  
 B2 : PZM = note 3  
 B1 : PP1 = note 4  
 B0 : PP0 = note 4

**note 1:**

C3,C2,C1,C0 = Country  
 0,0,0,0 = ? Not allowed  
 0,0,0,1 = D Germany  
 0,0,1,0 = A Austria  
 0,0,1,1 = CH Switzerland  
 0,1,0,0 = I Italy  
 0,1,0,1 = F France  
 0,1,1,0 = B Belgium  
 0,1,1,1 = DK Denmark  
 1,0,0,0 = S Sweden  
 1,0,0,1 = N Norway  
 1,0,1,0 = SF Finland  
 1,0,1,1 = GB Great Britain  
 1,1,0,0 = NL Netherlands  
 1,1,0,1 = P Portugal  
 1,1,1,0 = E Spain  
 1,1,1,1 = TR Turkey

**note 2:****P/V : PLL / VST bit**

1 : = VST Tuner  
 0 : = PLL Tuner

**note 3:****PZM : PIP zoom mode**

1 : = 16 : 9  
 0 : = 4:3

**note 4:****PP1, PP0 : PIP position**

00 : = LEFT-TOP  
 01 : = LEFT-BOTTOM  
 10 : = RIGHT-BOTTOM  
 11 : = RIGHT-TOP

**Option 08 Tube Size, Default Zoom mode, IF Frequency**

B7 : Tub = note 1  
 B6 : Z.Def = note 2  
 B5 : IfI = note 3  
 B4 : IfD = note 4  
 B3 : IfM = note 5  
 B2 : Aps = note 6  
 B1 : Hp = note 7  
 B0 : Hue = note 8

**note 1:**

Tub : Tube size  
 0 = 16:9 Tube size  
 1 = 4:3 Tube size

**note 2:**

Z.Def : Zoom Default Mode  
 0 = 16:9 mode default  
 1 = 4:3 mode default

**note 3:**

IfI  
 0 = IF I 39.5 MHz Great Britain I, Only UHF Tuner  
 1 = IF I 38.9 MHz Ireland I+, Standard Tuner

**note 4:**

IfD  
 0 = IF DK 38.0 MHz  
 1 = IF DK 38.9 MHz

**note 5:**

IfM  
 0 = IF M,N 45.75 MHz S&N American Models, Tuner UV1336 (Only Pal M/N, Ntsc M)  
 1 = IF M,N 38.9 MHz Euro M,N Models, Standard Tuner

**Note 6:**

Aps ( Only for PLL )  
 0 = A.P.S. done  
 1 = A.P.S. set

**note 7:**

Hp : Headphone available  
 0 = No headphone  
 1 = Headphone available

**note 8:**

Hue : Hue Available  
 0 = No hue  
 1 = Hue available

**Option 09 Standard Available**

B7 : NM = note 1  
 B6 : PN = note 1  
 B5 : PM = note 1  
 B4 : K1 = note 1  
 B3 : L = note 1  
 B2 : I = note 1  
 B1 : DK = note 1  
 B0 : BG = note 1

**note 1:**

0 = Standard not supported  
 1 = Standard available

**Option 10 Scart, Combfilter, Teletext Language**

B7 : TXL2 = note 1  
 B6 : TXL1 = note 1  
 B5 : TXL0 = note 1  
 B4 : Com = note 2  
 B3 : Svh = note 3  
 B2 : Fro = note 4  
 B1 : Sc2 = note 5  
 B0 : .. = x

**note 1:**

TXL2, TXL1, TXL0: Primary Language

000 = WEST, {{ENGLISH}, {FRENCH}, {SCAND}, {CZECH }, {GERMAN}, {SPANISH}, {ITALIAN}, {ENGLISH }}  
 001 = WEST-EAST{{POLISH}, {FRENCH}, {SCAND}, {CZECH}, {GERMAN}, {SERBIAN}, {ITALIAN}, {RUMANIAN}}  
 010 = WEST-TR{{ENGLISH}, {FRENCH}, {SCAND}, {TURKISH}, {GERMAN}, {SPANISH}, {ITALIAN}, {GREEK}}  
 011 = EAST (Cyrillic) {{ENGLISH}, {RUSSIAN}, {HUNGARIAN}, {CZECH}, {GERMAN}, {UKRAINIAN}, {LETTISH}, {RUMANIAN}}  
 100 = ARABIC{{ENGLISH}, {FRENCH}, {ENGLISH}, {ENGLISH}, {ENGLISH}, {HEBREW}, {ENGLISH}, {ARABIC}}

**note 2:**

0 = Comb filter not supported  
 1 = Comb filter available

**note 3:**

0 = S-VHS not supported  
 1 = S-VHS available

**note 4:**

0 = Front/Back AV (AV-3) not supported  
 1 = Front/Back AV (AV-3) available

**note 5:**

0 = Scart 2 not supported  
 1 = Scart 2 available

**Option 11 PII tuner control 1 byte**

B7 : b7 = note 1  
 B6 : b6 = note 1  
 B5 : b5 = note 1  
 B4 : b4 = note 1  
 B3 : b3 = note 1  
 B2 : b2 = note 1  
 B1 : b1 = note 1  
 B0 : b0 = note 1

**note 1 :**

PII tuner control 1 byte

		b7	b6	b5	b4	b3	b2	b1	b0
Philips	UV1316MK2	1	0	0	0	1	1	1	0
Alps	TELE9X062A	1	0	0	0	1	1	1	0
Samsung	TEXX2949PG28A	1	0	0	0	1	1	1	0
Siel	PT060	1	0	0	0	1	1	1	0
Temic	5001PH5-3X0003	1	0	0	0	1	1	1	0
Thomson	CTT5020	1	0	0	0	1	1	1	0

**Option 12 PII tuner control 2 low byte**

B7 : b7 = note 1  
 B6 : b6 = note 1  
 B5 : b5 = note 1  
 B4 : b4 = note 1  
 B3 : b3 = note 1  
 B2 : b2 = note 1  
 B1 : b1 = note 1  
 B0 : b0 = note 1

**note 1 :**

PII tuner control 2 low byte

		b7	b6	b5	b4	b3	b2	b1	b0
Philips	UV1316MK2	1	0	1	0	0	0	0	1
Alps	TELE9X062A	0	0	0	0	0	0	0	1
Samsung	TEXX2949PG28A	0	0	0	0	0	0	0	1
Siel	PT060	0	1	1	0	0	0	0	0
Temic	5001PH5-3X0003	0	0	0	0	0	0	1	0
Thomson	CTT5020	0	0	0	0	0	0	1	1

**Option 13 PII tuner control 2 mid byte**

B7 : b7 = note 1  
 B6 : b6 = note 1  
 B5 : b5 = note 1  
 B4 : b4 = note 1  
 B3 : b3 = note 1  
 B2 : b2 = note 1  
 B1 : b1 = note 1  
 B0 : b0 = note 1

**note 1 :**

PII tuner control 2 mid byte

		b7	b6	b5	b4	b3	b2	b1	b0
Philips	UV1316MK2	1	0	0	1	0	0	1	0
Alps	TELE9X062A	0	0	0	0	0	0	1	0
Samsung	TEXX2949PG28A	0	0	0	0	0	0	1	0
Siel	PT060	0	1	0	1	0	0	0	0
Temic	5001PH5-3X0003	0	0	0	0	0	1	0	0
Thomson	CTT5020	0	0	0	0	0	1	1	0

**Option 14 PII tuner control 2 high byte**

B7 : b7 = note 1  
 B6 : b6 = note 1  
 B5 : b5 = note 1  
 B4 : b4 = note 1  
 B3 : b3 = note 1  
 B2 : b2 = note 1  
 B1 : b1 = note 1  
 B0 : b0 = note 1

**note 1 :**

PLL tuner control 2 high byte

		b7	b6	b5	b4	b3	b2	b1	b0
Philips	UV1316MK2	0	0	1	1	0	1	0	0
Alps	TELE9X062A	0	0	0	0	1	0	0	0
Samsung	TEXX2949PG28A	0	0	0	0	1	0	0	0
Siel	PT060	0	0	1	1	0	0	0	0
Temic	5001PH5-3X0003	0	0	0	0	0	0	0	1
Thomson	CTT5020	1	0	0	0	0	1	0	1

**Option 15 PLL tuner VHF LOW - VHF HIGH crossover low byte**

B7 :	b7	=	note 1
B6 :	b6	=	note 1
B5 :	b5	=	note 1
B4 :	b4	=	note 1
B3 :	b3	=	note 1
B2 :	b2	=	note 1
B1 :	b1	=	note 1
B0 :	b0	=	note 1

**note 1 :**

PLL tuner VHF LOW - VHF HIGH crossover low byte

		b7	b6	b5	b4	b3	b2	b1	b0	
Philips	UV1316MK2	0	0	0	0	1	0	1	0	(0A hex)
Alps	TELE9X062A	0	0	0	0	0	0	0	0	
Samsung	TEXX2949PG28A	0	0	0	0	1	0	0	0	
Siel	PT060	0	0	0	0	0	0	0	0	
Temic	5001PH5-3X0003	0	0	0	0	0	0	0	0	
Thomson	CTT5020	1	0	1	0	1	0	1	0	(AA hex)

**Option 16 PLL tuner VHF LOW - VHF HIGH crossover high byte**

B7 :	b7	=	note 1
B6 :	b6	=	note 1
B5 :	b5	=	note 1
B4 :	b4	=	note 1
B3 :	b3	=	note 1
B2 :	b2	=	note 1
B1 :	b1	=	note 1
B0 :	b0	=	note 1

**note 1 :**

PLL tuner VHF LOW - VHF HIGH crossover high byte

		b7	b6	b5	b4	b3	b2	b1	b0	
Philips	UV1316MK2	0	0	0	0	1	1	0	0	(0C hex)
Alps	TELE9X062A	0	0	0	0	0	0	0	0	
Samsung	TEXX2949PG28A	0	0	0	0	1	1	0	1	
Siel	PT060	0	0	0	0	0	0	0	0	
Temic	5001PH5-3X0003	0	0	0	0	0	0	0	0	
Thomson	CTT5020	0	0	0	0	1	0	0	1	(09 hex)

**Option 17 PLL tuner VHF HIGH - UHF crossover low byte**

B7 :	b7	=	note 1
B6 :	b6	=	note 1
B5 :	b5	=	note 1
B4 :	b4	=	note 1
B3 :	b3	=	note 1
B2 :	b2	=	note 1
B1 :	b1	=	note 1
B0 :	b0	=	note 1

**note 1 :**

PLL tuner VHF HIGH - UHF crossover low byte

		b7	b6	b5	b4	b3	b2	b1	b0	
Philips	UV1316MK2	1	1	1	0	0	0	1	0	(E2 hex)
Alps	TELE9X062A	0	0	0	0	0	0	0	0	
Samsung	TEXX2949PG28A	1	0	1	0	0	0	1	0	
Siel	PT060	0	0	0	0	0	0	0	0	
Temic	5001PH5-3X0003	0	0	0	0	0	0	0	0	
Thomson	CTT5020	1	0	1	0	0	0	1	0	(A2 hex)

**Option 18. PII tuner VHF HIGH - UHF crossover high byte**

B7 : b7 = note 1  
 B6 : b6 = note 1  
 B5 : b5 = note 1  
 B4 : b4 = note 1  
 B3 : b3 = note 1  
 B2 : b2 = note 1  
 B1 : b1 = note 1  
 B0 : b0 = note 1

**note 1 :**

PII tuner VHF HIGH - UHF crossover high byte

		b7	b6	b5	b4	b3	b2	b1	b0	
Philips	UV1316MK2	0	0	0	1	1	1	1	0	(1D hex)
Alps	TELE9X062A	0	0	0	0	0	0	0	0	
Samsung	TEXX2949PG28A	0	0	0	1	1	1	1	0	
Siel	PT060	0	0	0	0	0	0	0	0	
Temic	5001PH5-3X0003	0	0	0	0	0	0	0	0	
Thomson	CTT5020	0	0	0	1	1	0	1	1	(1B hex)

**Option 19 PIP PII tuner control 1 byte**

B7 : b7 = note 1  
 B6 : b6 = note 1  
 B5 : b5 = note 1  
 B4 : b4 = note 1  
 B3 : b3 = note 1  
 B2 : b2 = note 1  
 B1 : b1 = note 1  
 B0 : b0 = note 1

**note 1 :**

PII tuner control 1 byte

		b7	b6	b5	b4	b3	b2	b1	b0
Philips	UV1316MK2	1	0	0	0	1	1	1	0
Alps	TELE9X062A	1	0	0	0	1	1	1	0
Samsung	TEXX2949PG28A	1	0	0	0	1	1	1	0
Siel	PT060	1	0	0	0	1	1	1	0
Temic	5001PH5-3X0003	1	0	0	0	1	1	1	0
Thomson	CTT5020	1	0	0	0	1	1	1	0

**Option 20 PIP PII tuner control 2 low byte**

B7 : b7 = note 1  
 B6 : b6 = note 1  
 B5 : b5 = note 1  
 B4 : b4 = note 1  
 B3 : b3 = note 1  
 B2 : b2 = note 1  
 B1 : b1 = note 1  
 B0 : b0 = note 1

**note 1 :**

PII tuner control 2 low byte

		b7	b6	b5	b4	b3	b2	b1	b0
Philips	UV1316MK2	1	0	1	0	0	0	0	1
Alps	TELE9X062A	0	0	0	0	0	0	0	1
Samsung	TEXX2949PG28A	0	0	0	0	0	0	0	1
Siel	PT060	0	1	1	0	0	0	0	0
Temic	5001PH5-3X0003	0	0	0	0	0	0	1	0
Thomson	CTT5020	0	0	0	0	0	0	1	1

**Option 21 PIP PII tuner control 2 mid byte**

B7 : b7 = note 1  
 B6 : b6 = note 1  
 B5 : b5 = note 1  
 B4 : b4 = note 1  
 B3 : b3 = note 1  
 B2 : b2 = note 1  
 B1 : b1 = note 1  
 B0 : b0 = note 1

**note 1 :**

PII tuner control 2 mid byte

		b7	b6	b5	b4	b3	b2	b1	b0
Philips	UV1316MK2	1	0	0	1	0	0	1	0
Alps	TELE9X062A	0	0	0	0	0	0	0	1
Samsung	TEXX2949PG28A	0	0	0	0	0	0	0	1
Siel	PT060	0	1	0	1	0	0	0	0
Temic	5001PH5-3X0003	0	0	0	0	0	0	1	0
Thomson	CTT5020	0	0	0	0	0	0	1	1

**Option 22 PIP PII tuner control 2 high byte**

B7 :	b7	=	note 1
B6 :	b6	=	note 1
B5 :	b5	=	note 1
B4 :	b4	=	note 1
B3 :	b3	=	note 1
B2 :	b2	=	note 1
B1 :	b1	=	note 1
B0 :	b0	=	note 1

**note 1 :**

PII tuner control 2 high byte

		b7	b6	b5	b4	b3	b2	b1	b0
Philips	UV1316MK2	0	0	1	1	0	1	0	0
Alps	TELE9X062A	0	0	0	0	1	0	0	0
Samsung	TEXX2949PG28A	0	0	0	0	1	0	0	0
Siel	PT060	0	0	1	1	0	0	0	0
Temic	5001PH5-3X0003	0	0	0	0	0	0	0	1
Thomson	CTT5020	1	0	0	0	0	1	0	1

**Option 23 PIP PII tuner VHF LOW - VHF HIGH crossover low byte**

B7 :	b7	=	note 1
B6 :	b6	=	note 1
B5 :	b5	=	note 1
B4 :	b4	=	note 1
B3 :	b3	=	note 1
B2 :	b2	=	note 1
B1 :	b1	=	note 1
B0 :	b0	=	note 1

**note 1 :**

PII tuner VHF LOW - VHF HIGH crossover low byte

		b7	b6	b5	b4	b3	b2	b1	b0	
Philips	UV1316MK2	0	0	0	0	1	0	1	0	(0A hex)
Alps	TELE9X062A	0	0	0	0	0	0	0	0	
Samsung	TEXX2949PG28A	0	0	0	0	1	0	0	0	
Siel	PT060	0	0	0	0	0	0	0	0	
Temic	5001PH5-3X0003	0	0	0	0	0	0	0	0	
Thomson	CTT5020	1	0	1	0	1	0	1	0	(AA hex)

**Option 24 PIP PII tuner VHF LOW - VHF HIGH crossover high byte**

B7 :	b7	=	note 1
B6 :	b6	=	note 1
B5 :	b5	=	note 1
B4 :	b4	=	note 1
B3 :	b3	=	note 1
B2 :	b2	=	note 1
B1 :	b1	=	note 1
B0 :	b0	=	note 1

**note 1 :**

PII tuner VHF LOW - VHF HIGH crossover high byte

		b7	b6	b5	b4	b3	b2	b1	b0	
Philips	UV1316MK2	0	0	0	0	1	1	0	0	(0C hex)
Alps	TELE9X062A	0	0	0	0	0	0	0	0	
Samsung	TEXX2949PG28A	0	0	0	0	1	1	0	1	
Siel	PT060	0	0	0	0	0	0	0	0	
Temic	5001PH5-3X0003	0	0	0	0	0	0	0	0	
Thomson	CTT5020	0	0	0	0	1	0	0	1	(09 hex)



**Option 25 PIP PII tuner VHF HIGH - UHF crossover low byte**

B7 : b7 = note 1  
 B6 : b6 = note 1  
 B5 : b5 = note 1  
 B4 : b4 = note 1  
 B3 : b3 = note 1  
 B2 : b2 = note 1  
 B1 : b1 = note 1  
 B0 : b0 = note 1

**note 1 :**

PII tuner VHF HIGH - UHF crossover low byte

		<b>b7 b6 b5 b4 b3 b2 b1 b0</b>	
Philips	UV1316MK2	1 1 1 0 0 0 1 0	(E2 hex)
Alps	TELE9X062A	0 0 0 0 0 0 0 0	
Samsung	TEXX2949PG28A	1 0 1 0 0 0 1 0	
Siel	PT060	0 0 0 0 0 0 0 0	
Temic	5001PH5-3X0003	0 0 0 0 0 0 0 0	
Thomson	CTT5020	1 0 1 0 0 0 1 0	(A2 hex)

**Option 26 PIP PII tuner VHF HIGH - UHF crossover high byte**

B7 : b7 = note 1  
 B6 : b6 = note 1  
 B5 : b5 = note 1  
 B4 : b4 = note 1  
 B3 : b3 = note 1  
 B2 : b2 = note 1  
 B1 : b1 = note 1  
 B0 : b0 = note 1

**note 1 :**

PII tuner VHF HIGH - UHF crossover high byte

		<b>b7 b6 b5 b4 b3 b2 b1 b0</b>	
Philips	UV1316MK2	0 0 0 1 1 1 1 0	(1D hex)
Alps	TELE9X062A	0 0 0 0 0 0 0 0	
Samsung	TEXX2949PG28A	0 0 0 1 1 1 1 0	
Siel	PT060	0 0 0 0 0 0 0 0	
Temic	5001PH5-3X0003	0 0 0 0 0 0 0 0	
Thomson	CTT5020	0 0 0 1 1 0 1 1	(1B hex)

**Option 27 LANGUAGE AVAILABLE 1**

B7 : L7 = DANISH  
 B6 : L6 = SWEDISH  
 B5 : L5 = ITALIAN  
 B4 : L4 = PORTUGUESE  
 B3 : L3 = SPANISH  
 B2 : L2 = FRENCH  
 B1 : L1 = GERMAN  
 B0 : L0 = ENGLISH

1 : Language available

0 : Language not available

**Option 28 LANGUAGE AVAILABLE 2**

B7 : L15 = RUSSIA  
 B6 : L14 = BULGARIAN  
 B5 : L13 = RUMANIAN  
 B4 : L12 = HRVATSKI  
 B3 : L11 = POLISH  
 B2 : L10 = CZECH  
 B1 : L9 = HUNGARY  
 B0 : L8 = TURKEY

1 : Language available

0 : Language not available

**Option 29 LANGUAGE AVAILABLE 3 and Zoom Mode Available**

B7 : ZSP = SUPER ZOOM MODE  
B6 : ZSB = SUBTITLE ZOOM MODE  
B5 : ZCN = CINEMA ZOOM MODE  
B4 : PMK = note 1  
B3 : L19 = Not used  
B2 : L18 = Not used  
B1 : L17 = ARABIC  
B0 : L16 = HEBREW

1 : Available  
0 : Not available

**note 1 :**

PMK : Picture mode key  
0 : Not available picture mode key from RC  
1 : available picture mode key from RC

**OPTION 38. TV TELETEXT MODE SELECTION, Child Lock, Equalizer, Country**

B7 : B7 = x  
B6 : C = note 2  
B5 : LM = 0  
B4 : EQ = 0  
B3 : ... = x  
B2 : CL = note 1  
B1 : T1 = x  
B0 : T0 = x

**note 1 :**

CL = Child Lock  
0 = Off  
1 = On (Active)

**note 2 :**

C = Country Line available / Aps available or not  
0 = Country Line not available / Aps not available  
1 = Country Line available / Aps available

**OPTION 50. FM PRESCALE**

B7 : b7 = note 1  
B6 : b6 = note 1  
B5 : b5 = note 1  
B4 : b4 = note 1  
B3 : b3 = note 1  
B2 : b2 = note 1  
B1 : b1 = note 1  
B0 : b0 = note 1

**note 1 :**

**b7 b6 b5 b4 b3 b2 b1 b0**

FM PRESCALE 0 0 0 0 1 1 0 0

**OPTION 51. NICAM PRESCALE**

B7 : b7 = note 1  
B6 : b6 = note 1  
B5 : b5 = note 1  
B4 : b4 = note 1  
B3 : b3 = note 1  
B2 : b2 = note 1  
B1 : b1 = note 1  
B0 : b0 = note 1

**note 1 :**

**b7 b6 b5 b4 b3 b2 b1 b0**

NICAM PRESCALE 0 0 1 0 1 1 0 1

**OPTION 52. SCART PRESCALE and AVL Bit**

B7 : b7 = note 1  
B6 : b6 = note 1  
B5 : b5 = note 1  
B4 : b4 = note 1  
B3 : b3 = note 1  
B2 : b2 = note 1  
B1 : b1 = note 1  
B0 : b0 = note 1

**note 1 :**

**b7 b6 b5 b4 b3 b2 b1 b0**

SCART PRESCALE 0 0 0 1 0 1 1 0

**OPTION 53. I2S PRESCALE**

B7 : b7 = note 1  
 B6 : b6 = note 1  
 B5 : b5 = note 1  
 B4 : b4 = note 1  
 B3 : b3 = note 1  
 B2 : b2 = note 1  
 B1 : b1 = note 1  
 B0 : b0 = note 1

**note 1 :**  
 I2S PRESCALE **b7 b6 b5 b4 b3 b2 b1 b0**  
 0 0 0 0 0 1 1 0

**OPTION 54. MSP SCART OUTPUT VOLUME**

B7:b7 = note 1  
 B6:b6 = note 1  
 B5:b5 = note 1  
 B4:b4 = note 1  
 B3:b3 = note 1  
 B2:b2 = note 1  
 B1:b1 = note 1  
 B0:b0 = note 1

**note 1 :**  
 MSP SCART OUTPUT VOLUME **b7 b6 b5 b4 b3 b2 b1 b0**  
 1 0 0 0 0 0 0 0

**OPTION 55. SPEAKER SETUP**

B7:b7 = note 1  
 B6:b6 = note 1  
 B5:b5 = note 1  
 B4:b4 = note 1  
 B3:b3 = note 1  
 B2:b2 = note 1  
 B1:b1 = note 1  
 B0:b0 = note 1

**note 1 :**  
 SPEAKER SETUP (L/R, L/C/R, L/R/S, L/C/R/S) **b7 b6 b5 b4 b3 b2 b1 b0**  
 0 0 0 0 0 0 0 0

**OPTION 56. AUDIO OPTIONS AVAILABLE OR NOT**

B7 : nicam = x  
 B6 : b6 = x  
 B5 : SRS = note 1  
 B4 : ... = x  
 B3 : ... = x  
 B2 : Bbe = note 2  
 B1 : Spa = note 3  
 B0 : Avl = note 4

**note 1 :**  
 SRS = TruSurround , TruBass , BBE  
 0 = SRS not available  
 1 = SRS available

**note 2 :**  
 Bbe = BBE (Analog BBE)  
 0 = BBE not available  
 1 = BBE available

**note 3 :**  
 Spa = Spatial Effect available  
 0 = Spatial Effect not available  
 1 = Spatial Effect available

**note 4 :**  
 Avl = Automatic volume level available  
 0 = Automatic volume level not available  
 1 = Automatic volume level available

**OPTION 57. STEREO THRESHOLD**

B7 : b7 = note 1  
B6 : b6 = note 1  
B5 : b5 = note 1  
B4 : b4 = note 1  
B3 : b3 = note 1  
B2 : b2 = note 1  
B1 : b1 = note 1  
B0 : b0 = note 1

Remark :

-Threshold for all FM A2 signals to switch from MONO to STEREO.  
-For first check after programme change half value is changed (0Ch) 19h/2  
-For switching from STEREO back to MONO: 19h/4 \*3

note 1 :

MSP STEREO/MONO THRESHOLD

**b7 b6 b5 b4 b3 b2 b1 b0**  
0 0 0 1 1 0 0 1

**OPTION 58. MSP AUDIO FLAGS**

B7 : b7 = x  
B6 : b6 = x  
B5 : b5 = x  
B4 : Trs = note 1  
B3 : Trb = note 1  
B2 : Bbe = note 1  
B1 : Spa = note 1  
B0 : Avl = note 1

note 1 :

Defines whether the feature is toggled ON or OFF in the menu and stored.

0 :OFF  
1 :ON

**OPTION 59. Nicam Threshold**

B7 : b7 = note 1  
B6 : b6 = note 1  
B5 : b5 = note 1  
B4 : b4 = note 1  
B3 : b3 = note 1  
B2 : b2 = note 1  
B1 : b1 = note 1  
B0 : b0 = note 1

note 1 :

MSP NICAM THRESHOLD

**b7 b6 b5 b4 b3 b2 b1 b0**  
0 1 1 0 0 1 0 0

**OPTION 60. Power Delay Time**

B7 : L7 = note 1  
B6 : L6 = note 1  
B5 : L5 = note 1  
B4 : L4 = note 1  
B3 : L3 = note 1  
B2 : L2 = note 1  
B1 : L1 = note 1  
B0 : L0 = note 1

Note 1:

Default Value :            **L7   L6   L5   L4   L3   L2   L1   L0**  
                              0   0   1   1   0   0   0   0

## AK19PRO CHASSIS ADJUST SETTING

### ADJUST 00-65

ADJUST 00	=	White Point RED
ADJUST 01	=	White Point GREEN
ADJUST 02	=	White Point BLUE
ADJUST 03	=	AGC
ADJUST 04	=	IF-PLL Negative
ADJUST 05	=	IF-PLL Positive
ADJUST 06	=	Y-Delay PAL
ADJUST 07	=	Y-Delay SECAM
ADJUST 08	=	Y-Delay NTSC
ADJUST 09	=	Y-Delay OTHER
ADJUST 10	=	4:3 Vertical Zoom
ADJUST 11	=	4:3 Vertical Scroll
ADJUST 12	=	4:3 Horizontal Shift
ADJUST 13	=	4:3 Vertical Slope
ADJUST 14	=	4:3 Vertical Amplitude
ADJUST 15	=	4:3 S-correction
ADJUST 16	=	4:3 Vertical Shift
ADJUST 17	=	4:3 EW Width
ADJUST 18	=	4:3 EW Parabola Width
ADJUST 19	=	4:3 EW Corner Parabola
ADJUST 20	=	4:3 EW Trapezium
ADJUST 21	=	16:9 Vertical Zoom
ADJUST 22	=	16:9 Vertical Scroll
ADJUST 23	=	16:9 Horizontal Shift
ADJUST 24	=	16:9 Vertical Slope
ADJUST 25	=	16:9 Vertical Amplitude
ADJUST 26	=	16:9 S-correction
ADJUST 27	=	16:9 Vertical Shift
ADJUST 28	=	16:9 EW Width
ADJUST 29	=	16:9 EW Parabola Width
ADJUST 30	=	16:9 EW Corner Parabola
ADJUST 31	=	16:9 EW Trapezium
ADJUST 32	=	Cinema Vertical Zoom
ADJUST 33	=	Cinema Vertical Scroll
ADJUST 34	=	Cinema Horizontal Shift
ADJUST 35	=	Cinema Vertical Slope
ADJUST 36	=	Cinema Vertical Amplitude
ADJUST 37	=	Cinema S-correction
ADJUST 38	=	Cinema Vertical Shift
ADJUST 39	=	Cinema EW Width
ADJUST 40	=	Cinema EW Parabola Width
ADJUST 41	=	Cinema EW Corner Parabola
ADJUST 42	=	Cinema EW Trapezium
ADJUST 43	=	Subtitle Vertical Zoom
ADJUST 44	=	Subtitle Vertical Scroll
ADJUST 45	=	Subtitle Horizontal Shift
ADJUST 46	=	Subtitle Vertical Slope
ADJUST 47	=	Subtitle Vertical Amplitude
ADJUST 48	=	Subtitle S-correction
ADJUST 49	=	Subtitle Vertical Shift
ADJUST 50	=	Subtitle EW Width
ADJUST 51	=	Subtitle EW Parabola Width
ADJUST 52	=	Subtitle EW Corner Parabola
ADJUST 53	=	Subtitle EW Trapezium
ADJUST 54	=	Super Zoom Vertical Zoom
ADJUST 55	=	Super Zoom Vertical Scroll
ADJUST 56	=	Super Zoom Horizontal Shift
ADJUST 57	=	Super Zoom Vertical Slope
ADJUST 58	=	Super Zoom Vertical Amplitude
ADJUST 59	=	Super Zoom S-correction
ADJUST 60	=	Super Zoom Vertical Shift
ADJUST 61	=	Super Zoom EW Width
ADJUST 62	=	Super Zoom EW Parabola Width
ADJUST 63	=	Super Zoom EW Corner Parabola
ADJUST 64	=	Super Zoom EW Trapezium
ADJUST 65	=	OSD position

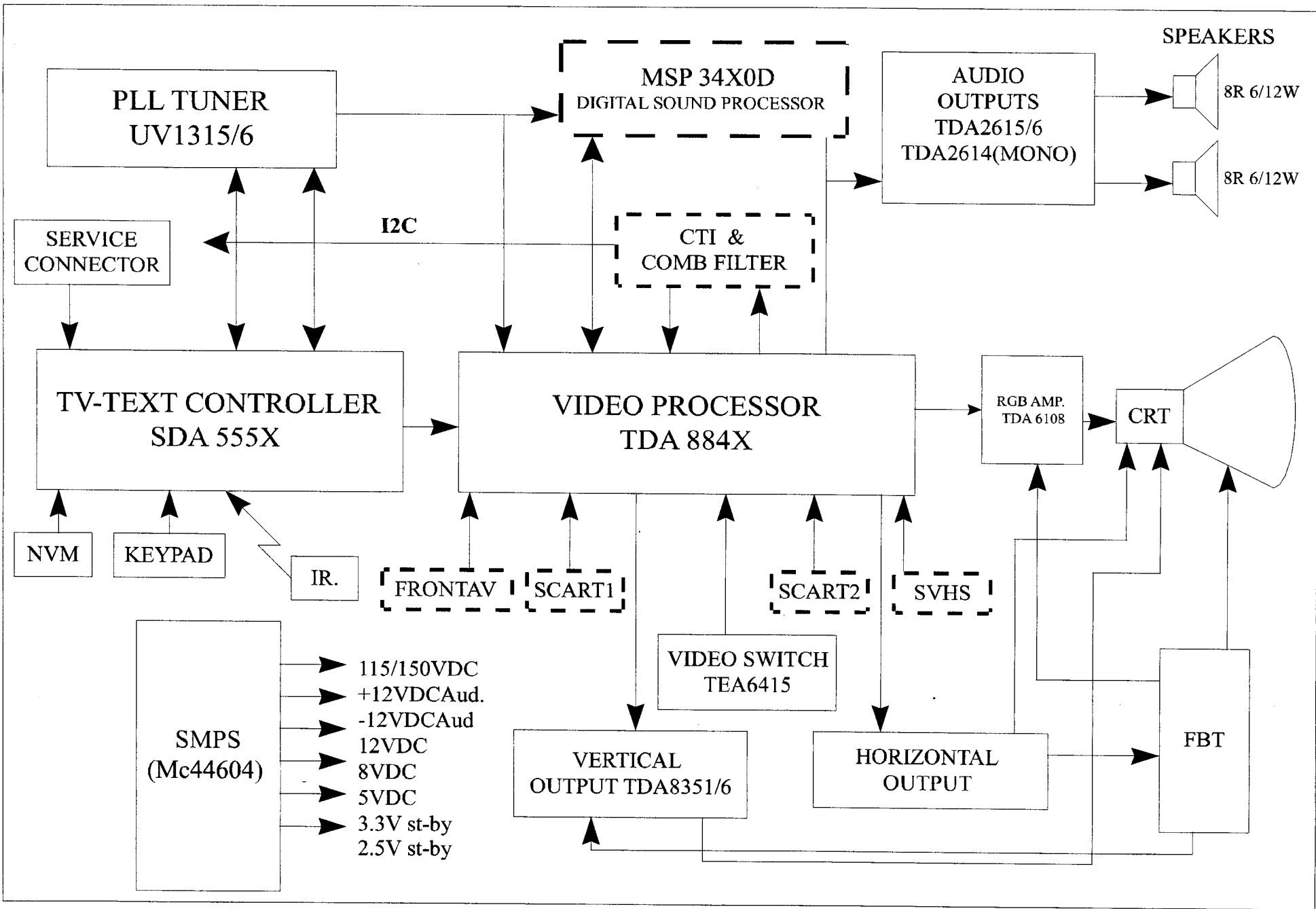

GENERAL BLOCK DIAGRAM OF CHASSIS AK19PRO

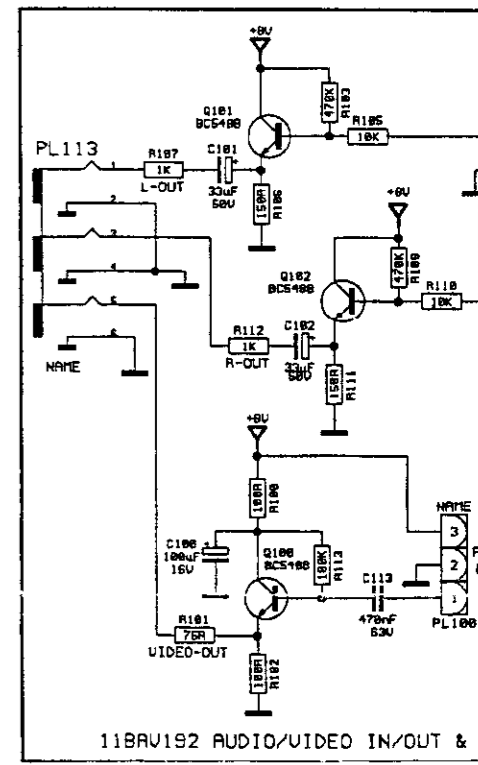
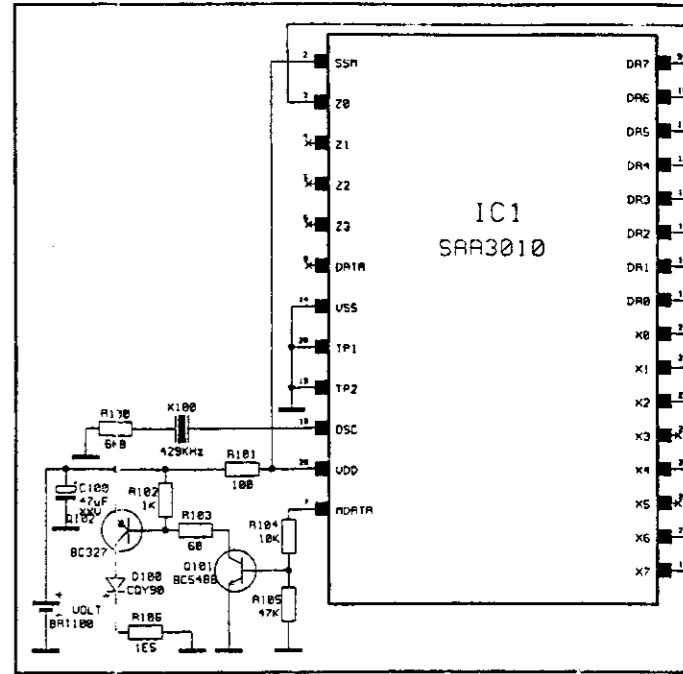
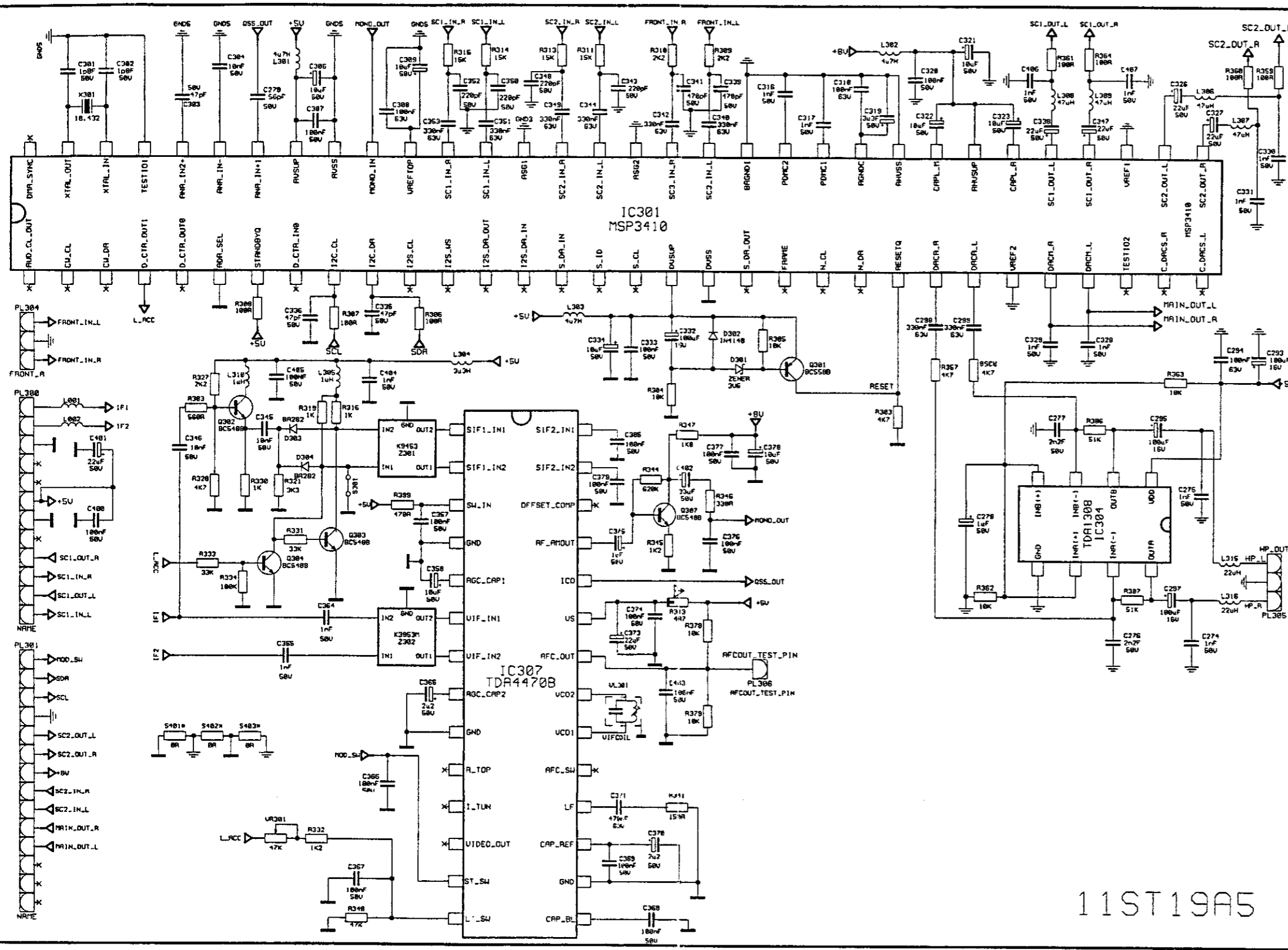

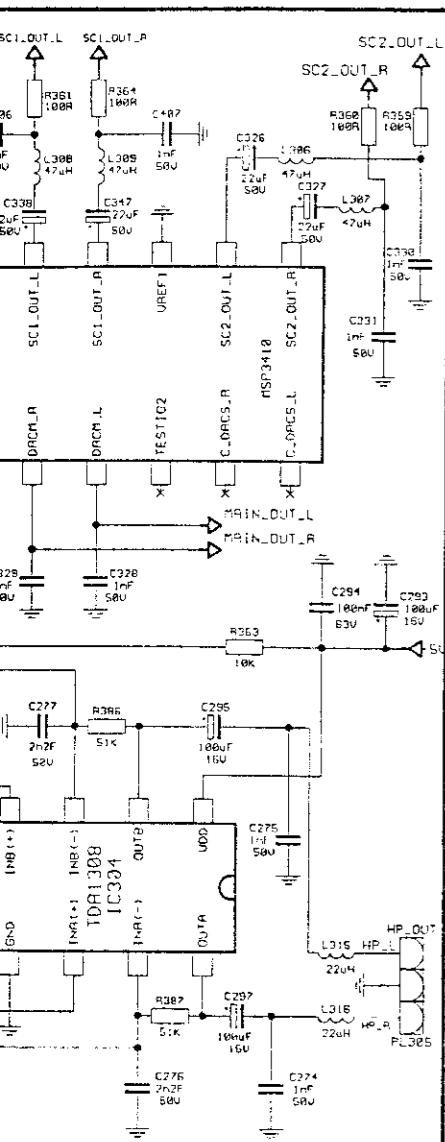

11ST19A5

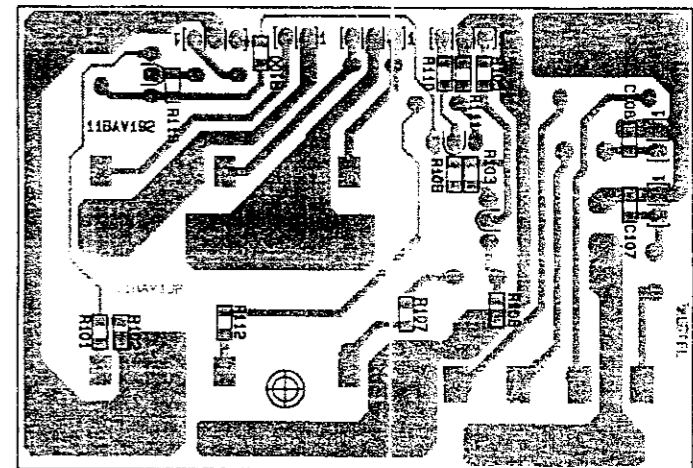
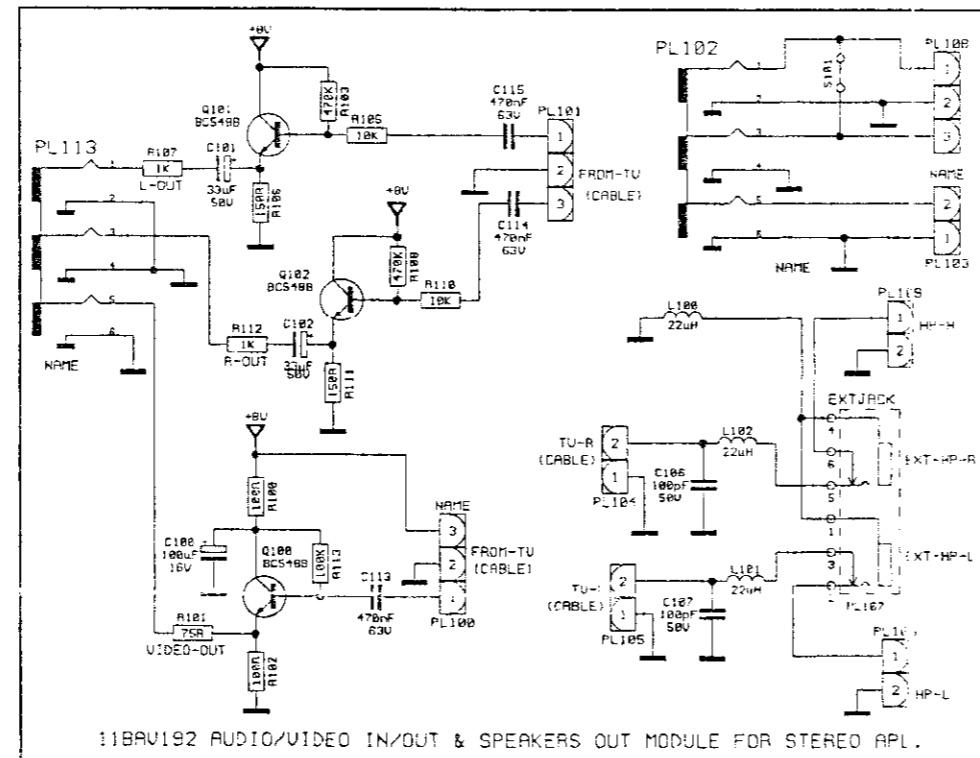
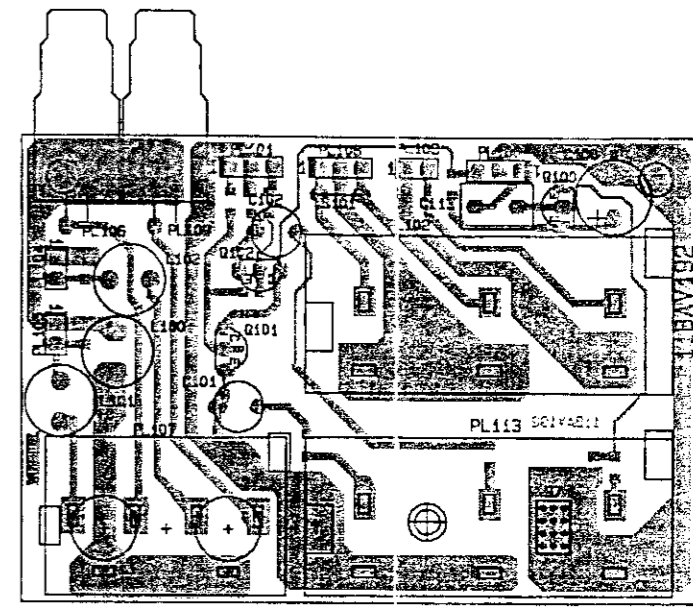
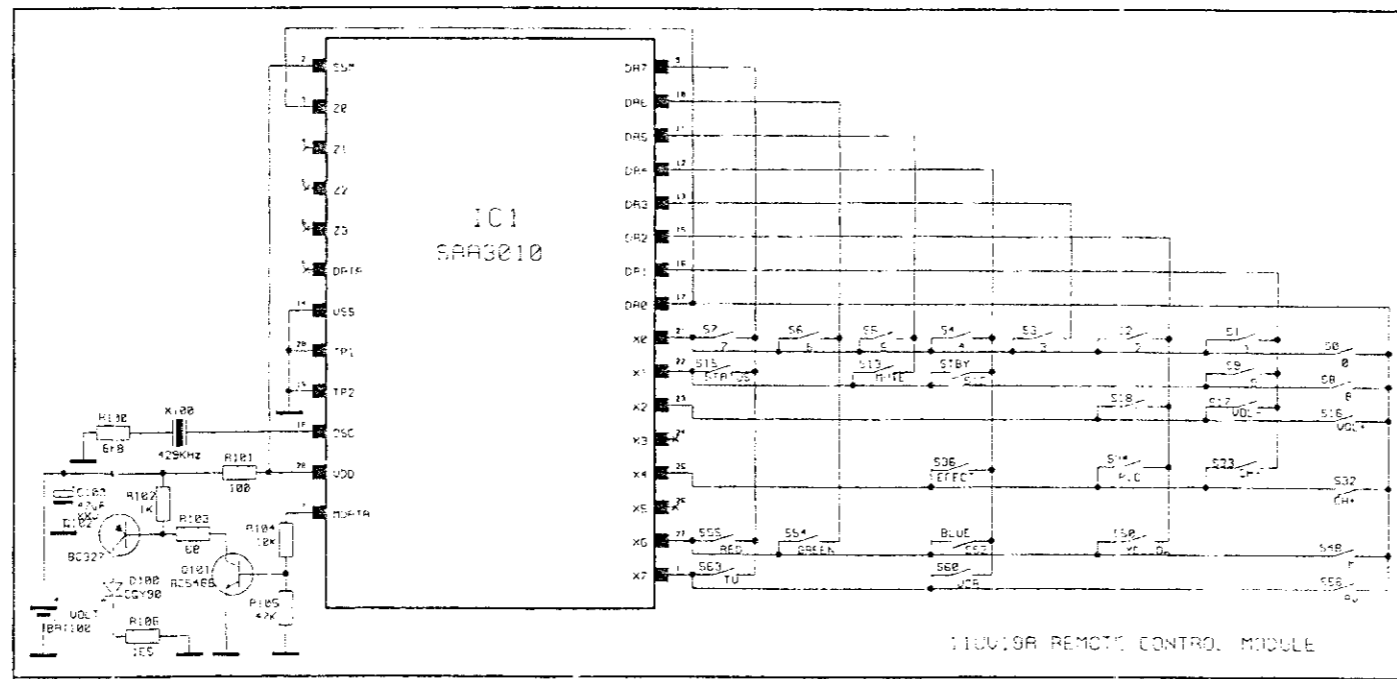



# 11CTFI9-2 CTI+COMB FILTER MODULE

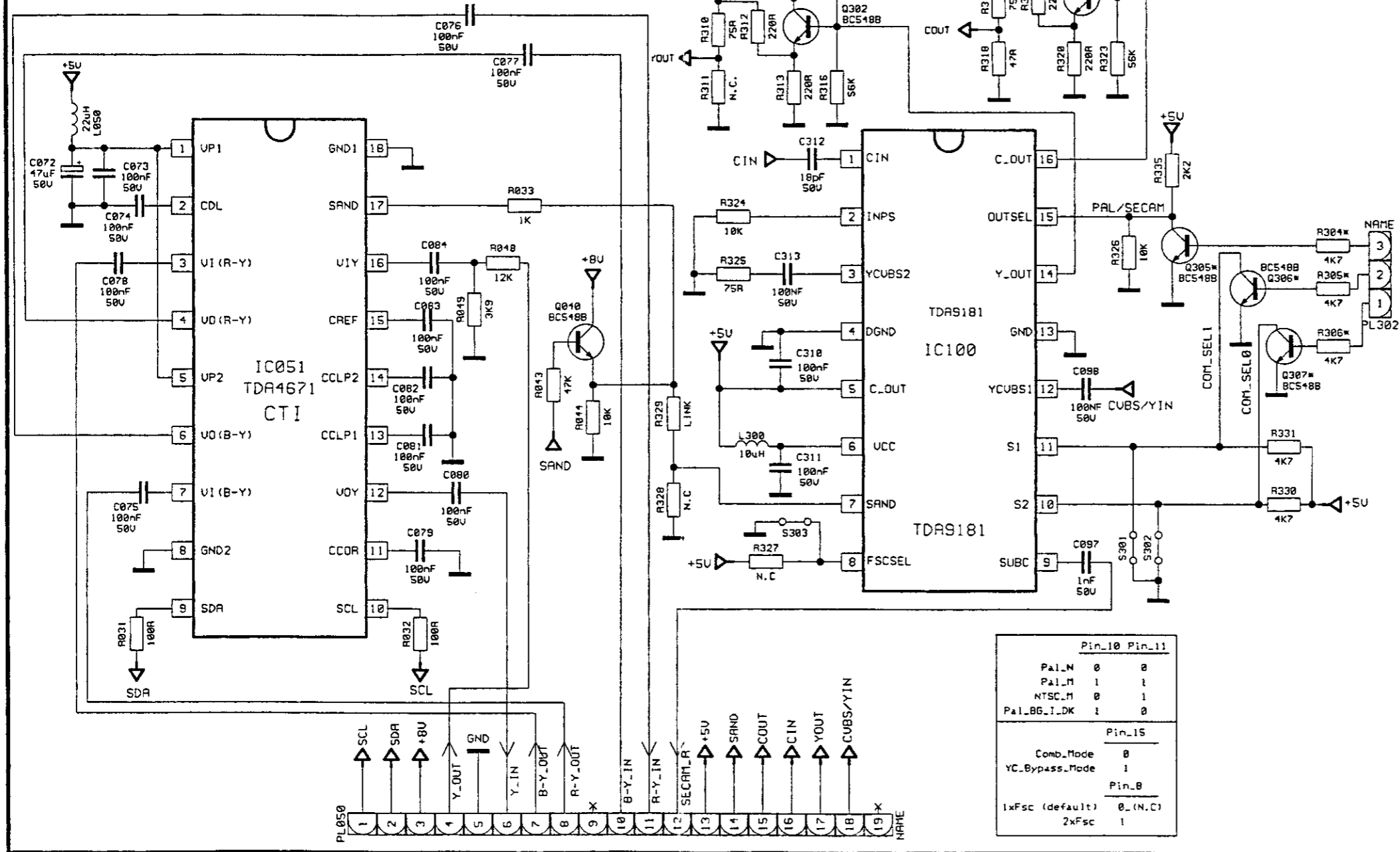

Pin_10	Pin_11
Pal_N	0
Pal_M	1
NTSC_M	0
Pal_BG_I_DK	1

  

Pin_15	
Comb_Mode	0
YC_Bypass_Mode	1

  

Pin_8	
1xFsc (default)	0 (N.C)
2xFsc	1

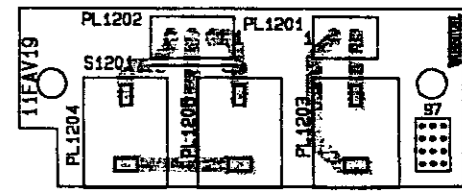
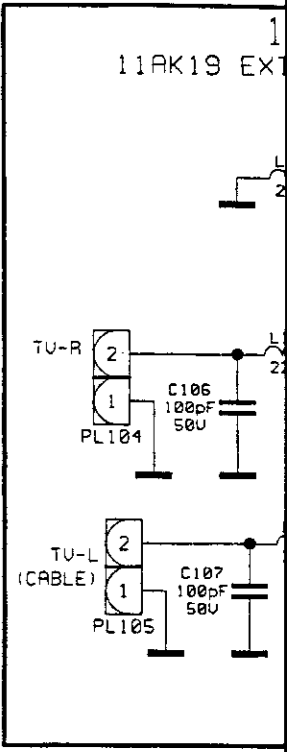

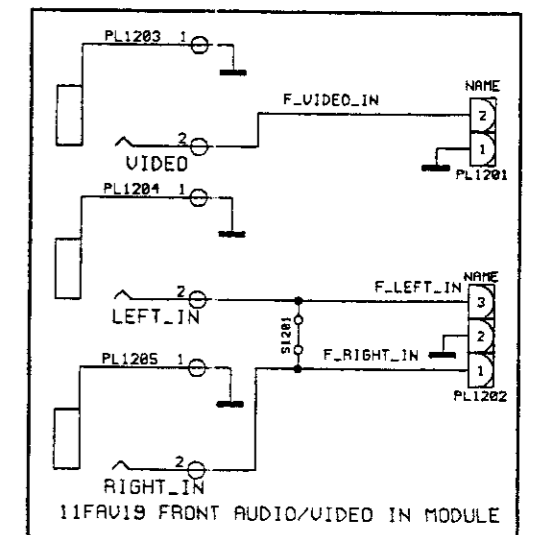
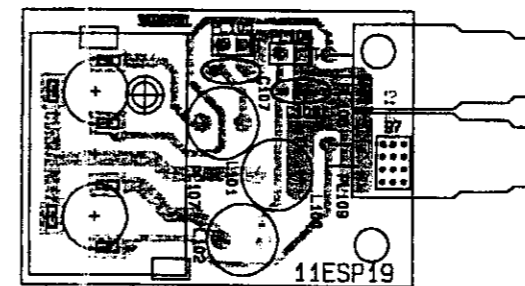
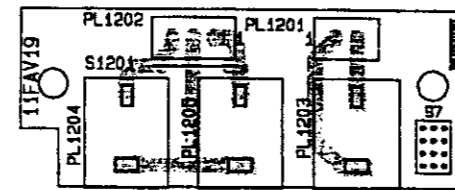
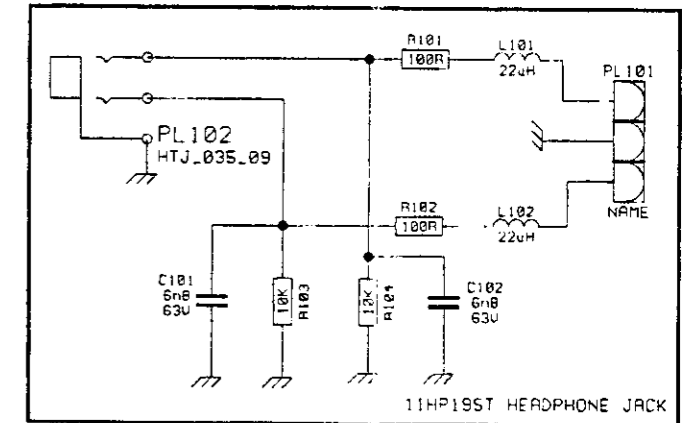
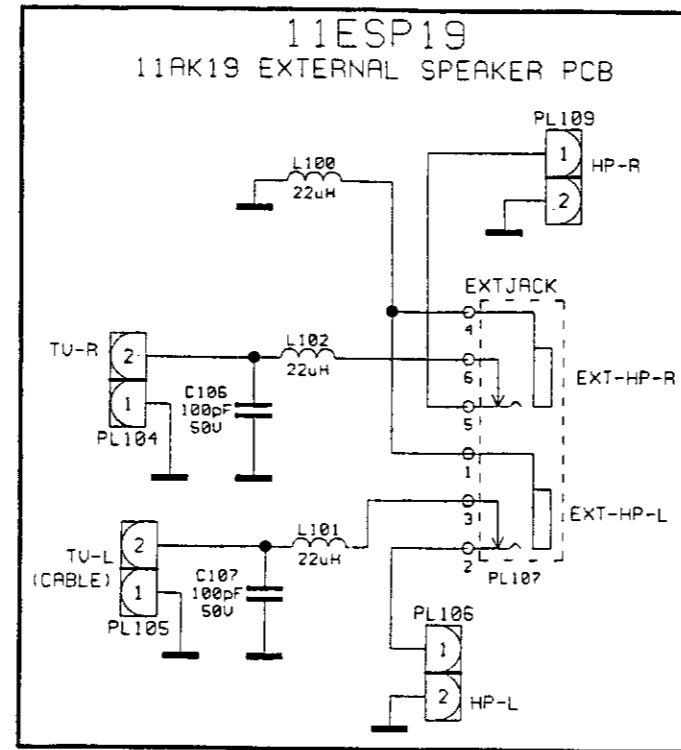
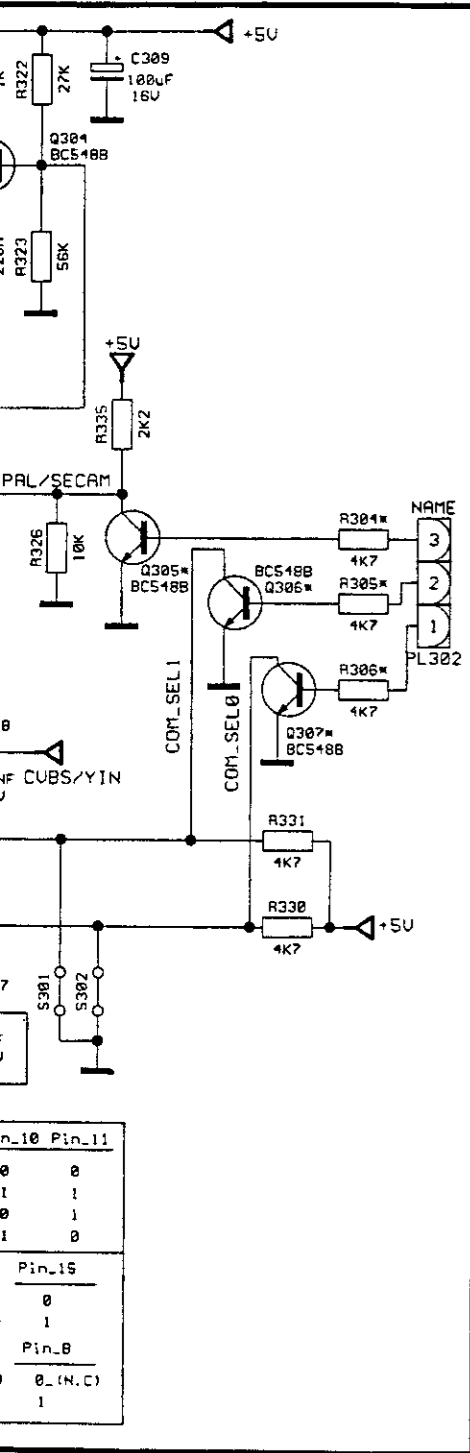

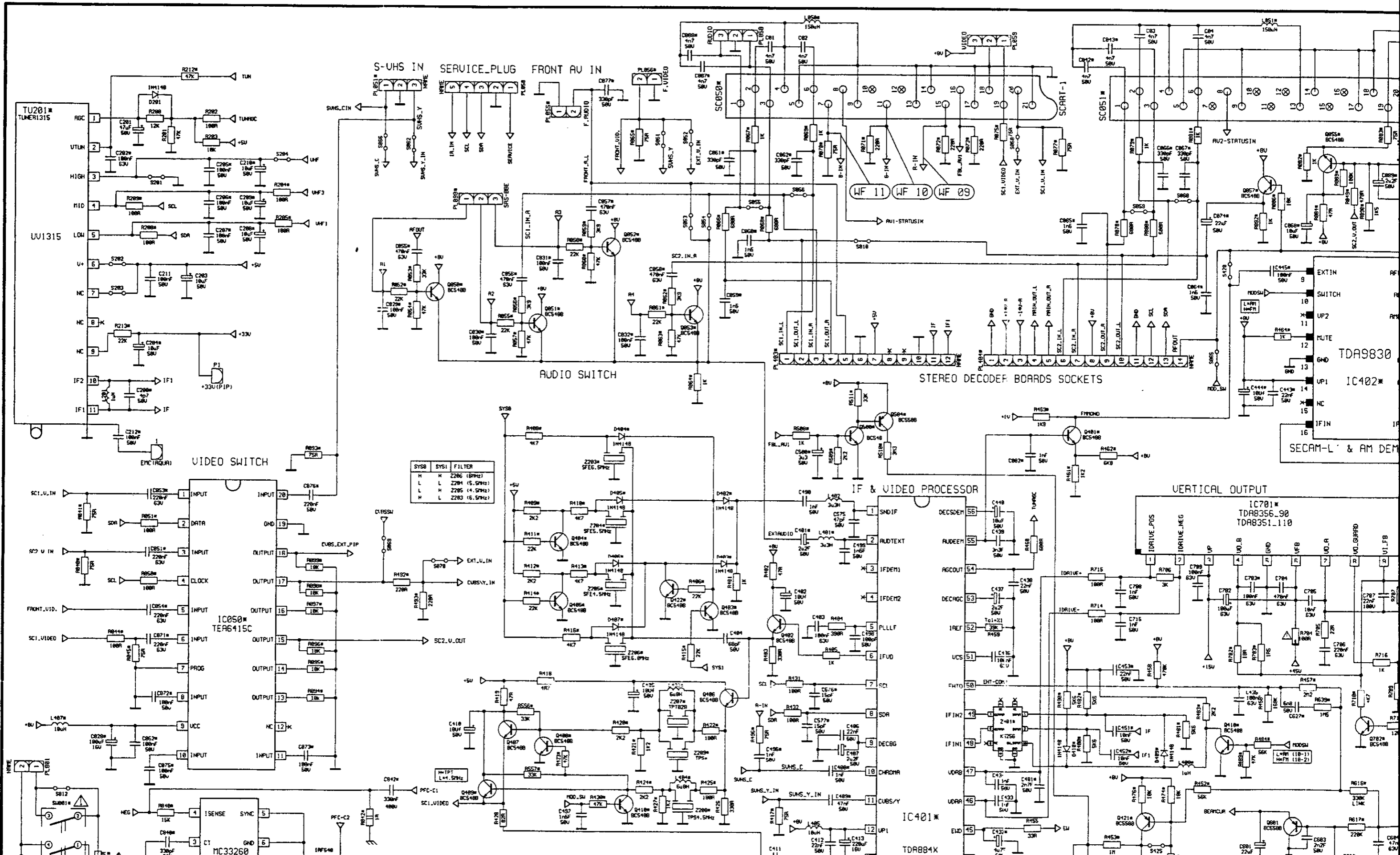
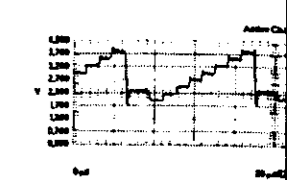
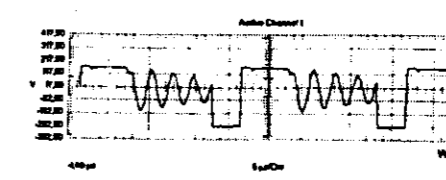
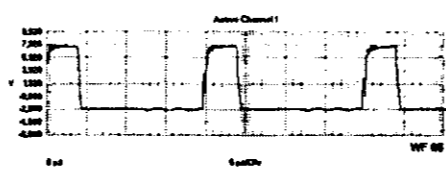
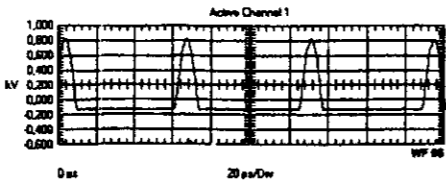
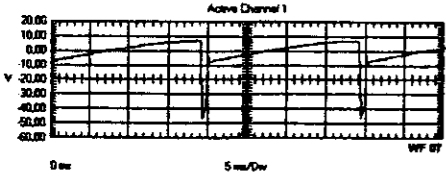

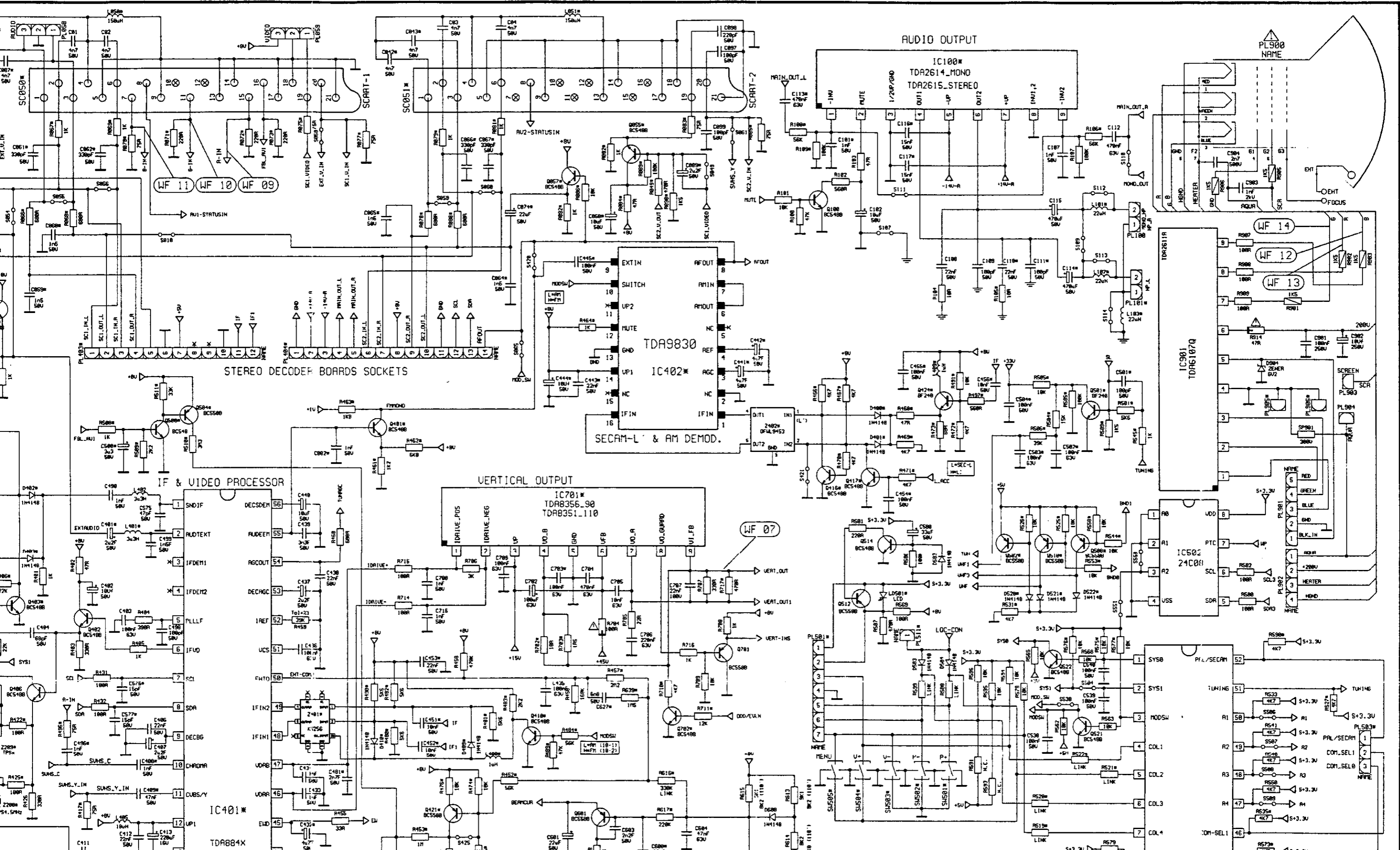
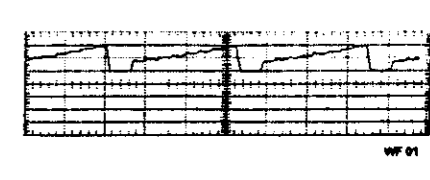
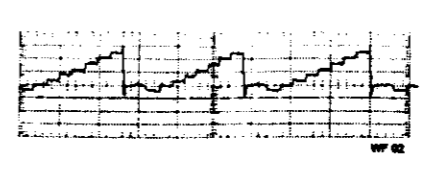
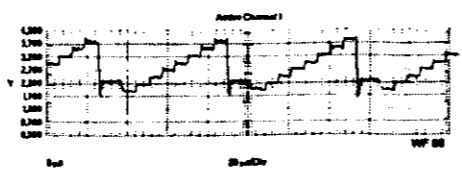
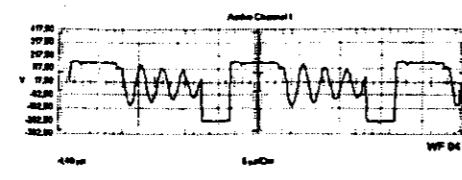
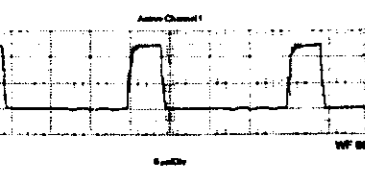

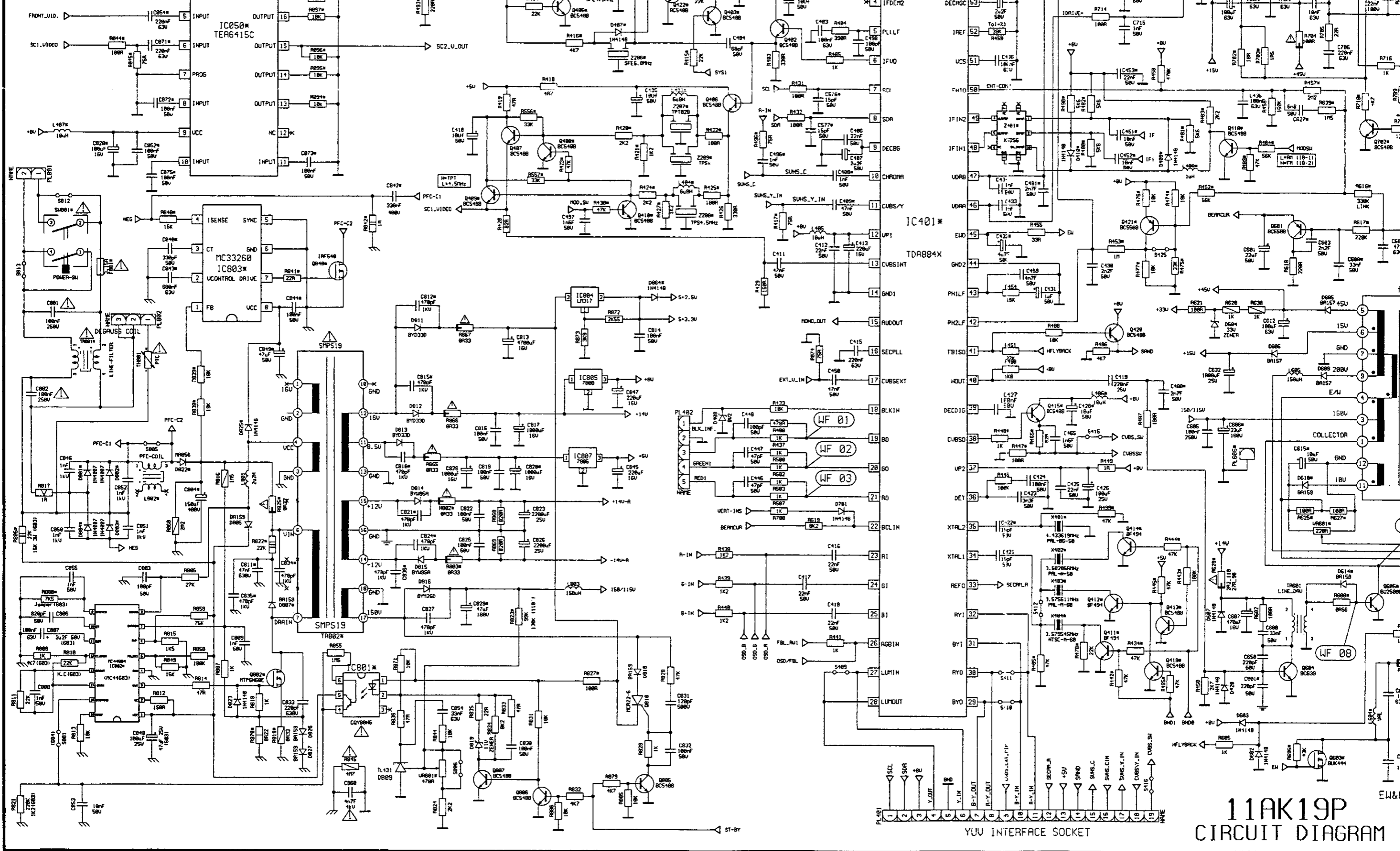

# 11AK19P CIRCUIT DIAGRAM

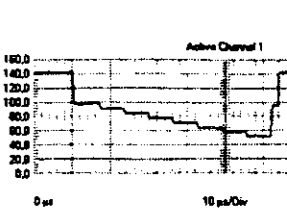
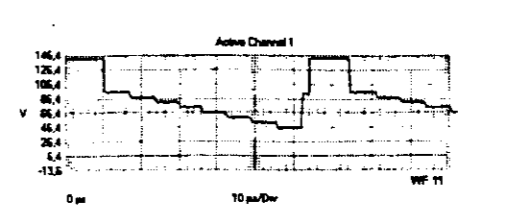
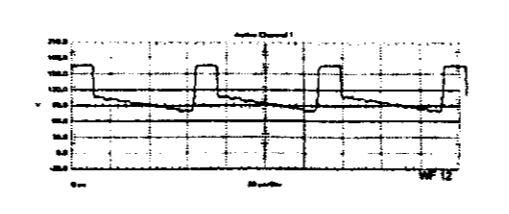
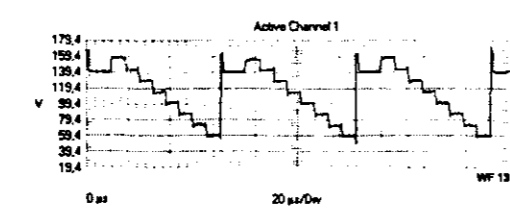
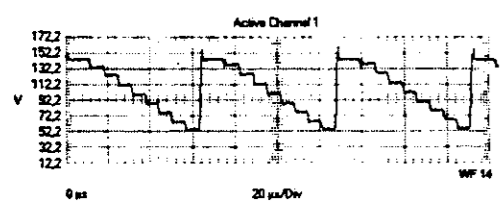

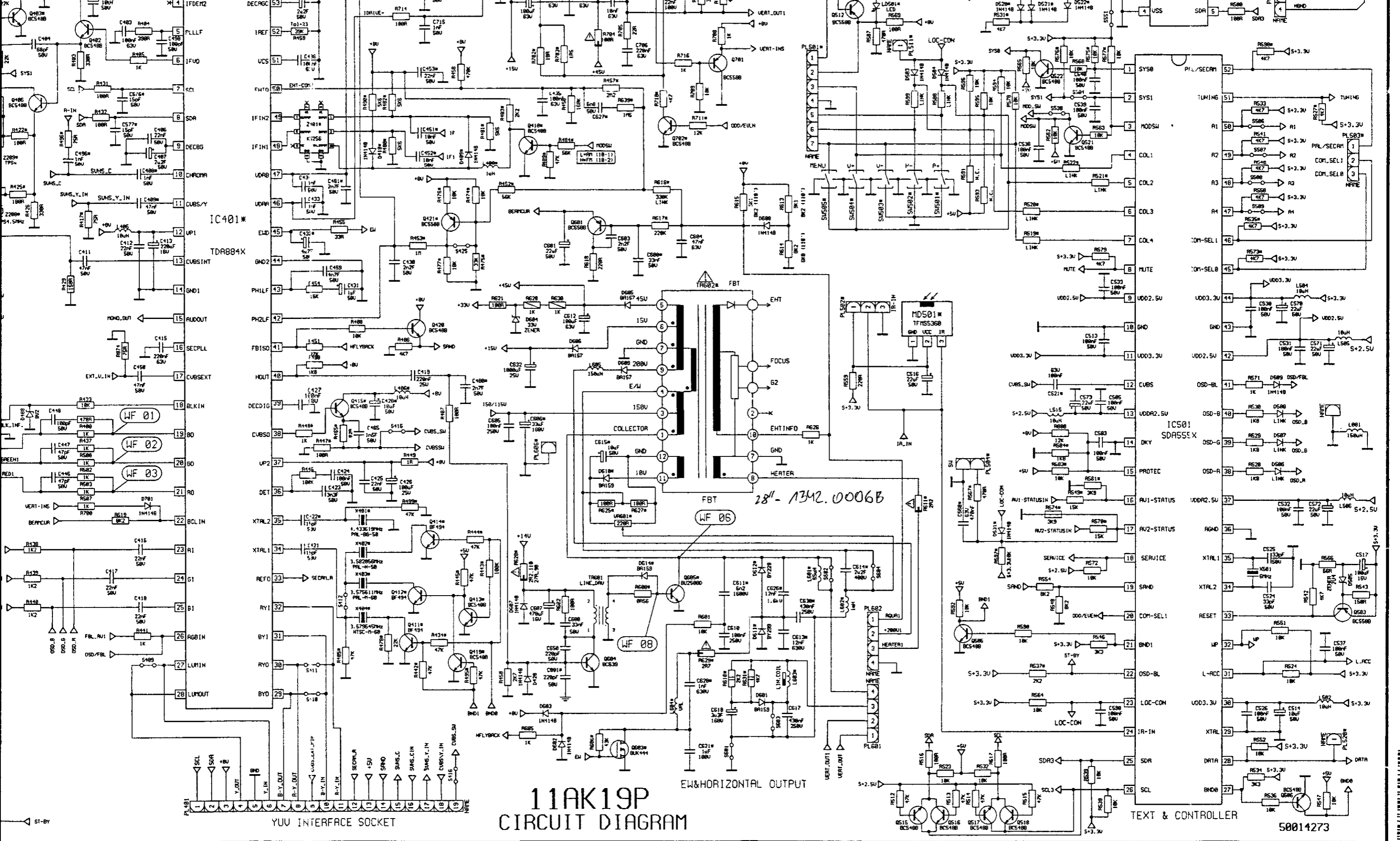

11AK19P  
CIRCUIT DIAGRAM

50014273

