

SERVICE INSTRUCTIONS

FOR

TRUVOX SERIES 100

SERVICE INSTRUCTIONS
FOR
TRUVOX SERIES 100

RECORDERS:—
R102, R104

TAPE UNITS:—
PD102, PD104

TRUVOX Ltd.,
Technical Advisory Bureau,
HYTHE,
SOUTHAMPTON.

CONTENTS

- Section 1 Introduction
2 Maintenance
3 Head Assembly
4 Pressure Pad Assembly
5 Reel Carriers and Brakes
6 Motors, Flywheel and Capstan
7 Idler Wheel and Speed Change
8 Tape Tension—Wind and Rewind
9 Cue (Pause) Control
10 Auto-Stop
11 Switches
12 Circuit Notes
13 Test Procedure
- Figure 1 Deck Layout
2 Head Assembly, Pinch Roller, etc. (Gate Closed)
3 Pinch Roller Assembly, Pause Control "Open"
4 Head Assembly, Front Elevation of Tape Guides
5 Head Assembly, Azimuth Adjustment
6 Recorder—Under-chassis Lay-out
7 P.D. Amplifier Lay-out
8 P.D. Amplifier—Switch Details
9 Printed Circuit Board—Pre-amp (No. 21538)
10 Printed Circuit Board—Power Amplifier (No. 21553)
Bias Oscillator (No. 21539)
11 Motor Circuits—Practical
12 Motor Circuits—100/125V
13 Motor Circuits—200/250V
14a Power Pack
14b Power Pack
15 Deleted
16a R102, R104 and R104D—Head Assembly Variants
16b R102, R104 and R104D—Circuit Diagram
16c R102, R104 and R104D—Track Switching Variants
17 PD102/PD104—Circuit Diagram
18 R102, R104 and R104D—Circuit Diagram (later models)

INTRODUCTION

1.1 The Series 100 Tape Recorders and Tape Units employ a deck which is basically the same as that used in the 90 Series, the deck mechanism is unchanged but a triple head assembly (two-track or four-track according to requirements) is fitted in all models.

The triple head arrangement (erase, record and play) in conjunction with the sophisticated circuitry, which employs transistors throughout, permits almost simultaneous play-back of the recorded material, without interruption of the recording process. An immediate comparison is thus possible between the original and the recording.

The Recorders are monophonic, the Units are Stereophonic but can be used monophonically as and when desired.

1.2 Production of this range started in March 1965 and machines of this Series bear Serial No.'s from 73,000 onwards.

MAINTENANCE

2.1 A certain amount of maintenance must be carried out. Once a month, more frequently if the machine is used for more than three hours daily, lift the hinged flap to expose the heads for cleaning. An accumulation of dust and of oxide from the tape will be seen on the head faces, this must be removed. Wrap a match or an orange stick with cotton wool, dip this in methylated spirits (alcohol) or in lighter fuel (gasoline), and gently but firmly wipe the head faces with this until they are clean. The tape guides should be cleaned in the same way if they appear dirty.

The capstan and pinch roller should also be cleaned, using spirits, petrol will damage the pinch roller.

ON NO ACCOUNT USE ANY METALLIC OBJECT TO ASSIST HEAD CLEANING.

2.2 The 3-speed motor pinion, the flywheel and the rubber idler must be kept clean and free from any trace of oil or grease. Clean these with methylated spirits, we do not recommend the use of cleaning fluids sold under various brand names, many of these contain powerful solvents which may attack and damage the plastic mouldings. The deck surfaces should be wiped over with a damp cloth occasionally.

2.3 Each of the two moulded covers is secured to the deck by two plated screws. The SPEED SELECTOR and the RECORD/PLAY control knobs will have to be pulled off to allow the larger cover to be removed. When both the covers have been taken off the deck will be seen as in Fig. 1.

TAKE CARE NOT TO TRAP THE AUTO-STOP LEVER INSIDE THE MOULDING WHEN REFITTING THE LARGE COVER.

2.4 Most of the bearings are of the self-lubricating type which should not normally require oiling. However, after a long period without use it may be advisable to apply a drop of oil to the motor bearings and to the bearings of the idler wheel and pinch roller. Use a non-metallic knitting needle or a similar object to convey a drop of fine oil to the place where it is needed.

DO NOT OVER-OIL.

HEAD ASSEMBLY

3.1 To completely expose the head assembly, remove the small cover. Clean the heads as described in Section 2.1 and then carefully examine them visually. If they show signs of considerable wear replacement may be necessary. The condition of the Record and Play heads can be checked by comparing the Record/Play characteristic with that given in the test specification; this is, however, inclined to be mis-leading, due to the possibility of a fault elsewhere in the system.

3.2 Heads should not be tested for continuity with an ohm-meter, or any device which relies on the passage of a D.C. current to establish proof of continuity unless means are available for demagnetising the heads. Do not over-look the possibility that the heads may have become magnetised as a result of having been so "tested" at some time or other, or by some other means. Magnetised Record and Play heads will result in excessive tape hiss. The heads may be effectively demagnetised by means of one or the other of the various defluxers which are on the market. It does no harm to regularly deflux the heads, even though it may not appear to be necessary. Heads should be tested on an inductance bridge, one which operates at 1,000 cps is recommended for this purpose. R102 and PD102 Erase heads have an inductance of 5mH and each section of both R104 and PD104 Erase heads also have an inductance of 5mH. The Record and Play heads in the R102 are alike, they have an inductance of 120mH and a D.C. resistance of 35 ohms. The Record and Play heads in the PD102 have the same inductance for each winding, but the resistance of each section is increased to 75 ohms. The quarter-track Record and Play heads used in R104 and PD104 are all identical, they also have an inductance of 120mH with a D.C. resistance of 170 ohms. The half-track heads in the R102 and the PD102 require a recording current of 120 μ A, the quarter-track heads in the R104 and PD104 need a recording current of 70 μ A. Recording bias should be 25V and Erase should be 60V at 90 Kc/s for all models.

3.3 Reference to the circuit diagram will show that the connections are straight-forward between the three heads and the relevant points in the circuitry, no switching being involved. Figs. 2, 4 and 5 together with the circuit diagram show that although there are circuit differences to suit the various head configurations the mechanics of head mounting and adjustment are identical to all models. All three heads are mounted on a plate 85 of Figs. 2, 4 and 5. The Erase head 76 is firmly bolted to the plate 85 but the height of the Record head 78 and the Play head 81 with reference to the Erase head is governed by the adjustment of the screws 17 and 20. These are pre-set so that the pole-faces of the three heads will be accurately aligned with reference to each other.

3.4 Do not readily suspect that heads are at fault if poor erasure or poor recording is experienced, heads are seldom the cause of failure, either in recording or playing. Poor recording and unsatisfactory erasure is almost certain to be due to low bias potentials and these should be checked using a valve-voltmeter for the purpose. If the erase bias volts are low it is almost certain that the recording bias potential will also be low and vice versa.

3.5 The circuitry associated with the individual heads is easily tested as there is no switching in the head circuits (apart from the track selection switches in the R104) and the screened cables connecting the amplifiers to the heads may be checked for continuity and for short-circuits between the inner and outer conductors of these cables using an ohm-meter in the usual manner. Before carrying out such a test, the actual leading-out wires from the heads should be disconnected from the lead-through pins 4, 5 and 11 of Fig. 1 in the case of R102/R104 and from the lead-throughs "a" to "k" as in Fig. 2 for PD102 or PD104.

3.6 Lead-through pins 3, 6 and 10 are the earth connections for the erase, record and play heads respectively in the R102 and R104.

3.7 In PD102 and PD104, connections to the lead-throughs are as follows:—

- a upper track, erase
- b common earth, erase
- c lower track, erase
- d earth, upper track, record
- e live, upper track, record
- f earth, lower track, record
- g live, lower track, record
- h earth, upper track, play

- i live, upper track, play
- j earth, upper track, play
- k live, upper track, play

3.8 In all cases care should be taken not to disturb the heads as this may involve resetting the azimuth adjustment and this is something to avoid if at all possible unless the test gear which is required for this adjustment is available.

Normal wear will necessitate the replacement of the heads in due time, and although the exchange of a head demands no great skill, the subsequent alignment of the heads and the setting of the azimuth can only be effected using the appropriate test gear.

3.9 Reference to Fig. 5 will reveal the head assembly fitted with quarter-track heads, it will be seen that there is a vertical gap in each poleface and it is, of course, across this gap that the magnetic field is developed during recording, or when a modulated tape is passed across the play head.

The high-frequency response of any tape recording equipment is, in the first instance, governed by the width of the gap in the head pole-face and with modern manufacturing techniques it has become possible to reduce this gap to microscopic dimensions and this has made it possible to efficiently record and play frequencies which though considered to be within the audio spectrum are, in fact, well above the limits of human perception. To gain the full benefit of the minute gap it is essential that the gap be exactly at right angles to the direction of tape travel across the head face, for, if the head is tilted so that the gap is no longer truly vertical the tape will actually cross the gap diagonally. This will present a wider gap to the tape and the response of the combination of head and tape will drop at the higher frequencies at a rate which will depend upon the deviation from the vertical; a deviation of only a few degrees can reduce the head output by more than 6 db at 10,000 cps, all other factors remaining unaltered.

The adjustment of the head azimuth is described later.

3.10 Erase Head—R102/R104

R102—using a small soldering iron and great care, unsolder the lead-out wires from the "ERASE OFF" switch and from the lead-through pin. Remove screw 15 (Fig. 1 and Fig. 5), this may be nipped at the base of the head. Fit and connect new head, check that it erases the full width of the track.

If the horizontal alignment of the erase head poleface is not accurate relative to the other heads it may be necessary to insert a "shim" between the erase head and plate 85. Alternatively, the record and play heads may be raised or lowered relative to plate 85 as described later. However, the close tolerances observed during manufacture of the tape guides 25, 26 and 27 and their assembly to plate 85 leave very little scope for altering the height of the record and play heads without them becoming misaligned with the tape, but the imposition of such close tolerances render it improbable that any difficulty will be experienced. In the event, examine the new head to see that no unevenness of the moulding exists, also check that there is no foreign matter either on the head or plate which could prevent the head from seating correctly.

R104—using a small soldering iron and great care, unsolder the lead-out wires from the track selector switch, note that the earthy ends of the windings are terminated on the track switch and not, as might be expected, on lead-through pin 3. See Figs. 16a and 16c.

Fit new head, connect up, check that it fully erases both tracks.

The notes regarding the erase head of R102 apply to this model also.

3.11 Record and Play Heads

All Models

Using a small soldering iron and exercising great care, remove all the connecting wires from the lead-through pins. Make a note of the colour code of the various connecting wires. Remove screws 86 and 87 and withdraw the head assembly complete. In the R104 only, unsolder the lead-out wires from the head concerned to the appropriate section of the track switch.

Do not disturb screws 17 or 20 at this stage, but remove screws 16 and 18 or 19 and 21 according to which head is to be changed. It is recommended that screw 16 (or 19), together with the spring, be removed first and screw 18 (or 21) secondly. When fitting the new head reverse the order in which these screws (and the spring) are reinserted. There are two dimples in the saddle upon which the head is mounted and in these the points of screws 17 (or 20) should locate. When the spring 77 (or 80) is in position on screw 16 (or 19) and the nut fitted on that screw, the azimuth adjustment screw, 18 (or 21), should be rotated until the horizontal plane of the substitute head appears to be in line with the other two heads, i.e., the upper edges of the record and play heads should be equidistant from plate 85. The upper edge of the erase head will be slightly nearer the plate 85 than the edges of the other heads, due to the greater width of the erase head's poleface.

Stretch a length of transparent leader tape tightly across tape guides 25, 26 and 27, (Fig. 4). Use a pen-torch to brightly illuminate the area of the head poleface, a watch-makers eye-glass will greatly assist inspection of the head. At this stage the aim should be to see that the upper edges of the record and play heads are level with the upper edge of the tape, under these conditions the upper edge of the erase head should be barely visible above the upper edge of the tape. Having adjusted the horizontal alignment in this manner by altering screws 17 (or 20), further adjustment of these screws may be necessary to bring the polefaces parallel to the tape in the vertical plane.

If polefaces are not parallel to the tape guides, and thus to the tape the pressure pads will press harder against the top or bottom of the poleface as the case may be. If a head is markedly mal-adjusted in this respect drop-outs may occur on the track upon which the least pressure is exerted, whilst excessive wear will occur on the track which is subjected to higher pressure.

Refit assembly and re-connect to lead-through pins.

Adjust azimuth as follows in 3.12.

3.12 Azimuth Adjustment

As explained in 3.9, the tonal quality of recording on tape is, in the first instance, determined by the width of the gap in the magnetic circuit of the head, other factors being equal. Consequently, no matter what other conditions may exist in the equipment in the form of treble boost circuits the efficiency with which the high-frequency components of the complicated wave structures of sounds are recorded depends primarily on this gap being precisely at right angles to the direction of tape travel. This is also true of the situation when playing a tape which carries recorded material.

METHOD—PLAY HEAD

First, check that the "play" amplifier(s) characteristics are the same as quoted in the instructions for testing these given under the heading of "Test Procedure".

Connect suitable meter to the pre-amplifier output socket R102/R104 or to the output socket, Left Channel, PD102 or PD104. If two meters are available the work will be simplified, with a meter for each output. Load the machine with a standard test tape.

Play the 8 Kc/s or 10 kc/s section of this tape at $7\frac{1}{2}$ " per second. Proceed as below.

R102—Adjust azimuth screw, 21, for maximum output.

R104—

- (a) Adjust azimuth screw to give maximum output on track 1-4. Note the reading obtained.
- (b) Operate the track switch and note the output obtained on 2-3.
- (c) Adjust the azimuth screw until the difference between these two readings is halved and note the new reading.
- (d) Return the track switch to 1-4 and note the output now obtained.
- (e) Again adjust the azimuth screw until the difference between the (c) and (d) readings has been halved.
- (f) Repeat (b), (c), (d) and (e) until both outputs are equal. The final output should not differ from the original as obtained at (a) by much more than -3 db.

PD102 and PD104

Proceed as for R104 but instead of operating the track switches transfer the meter from one output socket to the other. Adjust the azimuth screw until the output from each socket is equal to the other. If two meters are available, one for each output, the operation will be much easier. Both PLAYBACK controls should be at maximum during these adjustments.

METHOD—RECORD HEAD

First, check that the record amplifier(s) characteristics are the same as quoted in the instructions for testing these given under the heading of "Test Procedure".

Connect suitable meter to the pre-amplifier output socket R102/R104 or to the output socket, Left Channel, PD102/PD104. If two such meters are available, connect one to each output socket in the PD machines. Load the machine with a clean tape.

Connect signal generator to Radio/PU input socket. Link input sockets together in the case of the PD models.

Set machine to RECORD, turn Radio/Phono gain control to maximum. Set signal generator to 10 kc/s and set the output level of the signal generator to give a reading of -10 db on the VU meters. In PD models adjust signal level in conjunction with the gain controls to obtain equal readings on the VU meters.

Set VOLUME (PLAYBACK) controls at maximum.

The Monitor button on R102/R104 should be in the TAPE position.

The Monitor buttons on PD102/PD104 should both be "up".

Record the 10 kc/s signal at $7\frac{1}{2}$ " per second.

Whilst recording:—

R102—Adjust azimuth screw 18 for maximum output, reduce signal input if necessary to avoid over-loading.

R104—Follow the instructions for the play head, but adjust the screw 18 instead of 21, reduce the signal level if necessary to avoid distortion.

PD102 and PD104

Adjust azimuth screw 18 for equal output on each channel.

3.13 Experience suggests that signal generator and output meter may be more readily available than a standard test tape. In these circumstances it is possible to set the azimuths by following the procedure below:—

Set up the test gear as described in 3.12 and commence recording at 10 Kc/s.

Whilst recording:—

R102—Adjust screw 18 for maximum output if the azimuth of the record head needs correction, or, if the play head adjustment is to be corrected, adjust screw 21. If the azimuth of both heads needs adjustment, deal with the record head first as described above, and follow up by adjusting the play head, repeating the process until no further improvement in output appears possible.

R104—Proceed as above, but operate the track switches to ensure that the output is equal on each track as described in 3.12.

PD102 and PD104

Proceed as before. The aim is to modulate each track equally, (by adjusting the azimuth of the record head) and, by adjusting the azimuth of the play head, obtain equal output on each track and, as already stated, it will be much easier to carry out the adjustments if the two outputs can be metered simultaneously.

AVOID RANDOM ADJUSTMENTS.

PRESSURE PAD ASSEMBLY

4.1 The assembly is shown in detail in Figs. 1 and 2.

The three pad carriers 29, 35 and 36 are mounted on the carrier plate; when the START key is pressed, motion is imparted to the rod, 42, and this causes the cam, 53, to move the carrier plate, 43, which is pivoted at 34, towards the head assembly. The pressure pads are held against the heads by the tension of the springs, 44. Interference with these springs should be avoided as only a small increase in tension may cause wow to occur. It is anticipated that this part of the mechanism will not develop faults during the working life of the machine.

4.2 A spring, 51, ensures retraction of the assembly when the STOP key has been depressed.

REEL CARRIERS AND BRAKES

5.1 Refer to Fig. 6. The lever M, pivoted at N, is actuated when the START, FAST REWIND, or FAST WIND keys are depressed, the lever is connected to the brake assembly by a rigid link. Normally, when the machine is not running the brakes are held against the reel carriers by the action of an expanded spring. Pressing either of the keys mentioned above pulls the brake shoes clear of the reel carriers and the lever M is then locked in this position by the latch L, until released by pressing the STOP key.

5.2 An Allen (hexagonal) key, measuring .0625" across flats is required to undo the 4-B.A. socket grub screw securing each reel carrier to its motor. The take-up (right-hand) reel carrier provides a belt drive to the digital counter. If a reel carrier has been moved on the motor spindle the height of the reel above deck level should be carefully checked to ensure correct spooling of the tape. Provided that the motor is mounted correctly it will be found that when pushed right home on the motor spindle the reel carrier automatically acquires the right height.

5.3 When refitting a machine in its case see that the drive to the counter does not become fouled by flexible leads to loud-speaker etc.

5.4 It is not likely that the brakes will ever need renewing. However, if repair or replacement does become necessary the machine may have to be partially dismantled, this is not a simple or straightforward task, and in such an event it is recommended that the machine be sent to the factory for the work to be carried out. It is, of course, possible to work on the brakes without extensive dismantling and the engineer will have to decide on his course of action on the basis of what the actual fault happens to be.

5.5 If, for any reason, repairs have to be carried out on the spot, it is advisable to first remove the reel carriers and then place the deck upside down on a soft surface.

The brakes may now be sufficiently accessible to work on. Note the order in which the nuts and washers are taken off and take care to see that they are placed back in the correct sequence.

5.6 If partial dismantling has to be undertaken, proceed as follows:—

Unhook the link from lever M (Fig. 6) to the brakes.

Remove the strut between pre-amp chassis and the motor platform in the P.D. models.

In Recorders remove:—

- (a) Unit carrying oscillator and power amplifier boards.
- (b) Power pack.
- (c) Bracket carrying jack sockets.

In P.D. Models remove power pack.

Unlace and/or unsolder any leads which may impede adequate movement of the motor platform.

Remove the screws and nut securing motor platform to deck pillars.

Lift the motor platform free so that the brakes are accessible. Should there appear to be any risk of damage to the flywheel/capstan assembly withdraw this from the deck.

If a brake lever has to be removed note the order in which the various washers etc., are removed, ensure that these are put back in the right sequence.

Refitting of the capstan spindle and its thrust bearing is referred to in Section 6 which should be read in connection with the foregoing.

Take care not to damage the capstan assembly, it is possible to do so quite inadvertently.

MOTORS, FLYWHEEL AND CAPSTAN

6.1 Fig. 6 illustrates the underside of a Recorder chassis. This is not dissimilar to the underside of a P.D. machine for both models have the same deck as a common feature. The motor platform referred to in the previous Section carries the three motors together with the associated resistors and capacitors and the "U" shaped bracket which supports the lower thrust bearing for the capstan spindle.

Fig. 11 is a practical diagram of the motor circuits and associated switches; Figs. 12 and 13 are schematic diagrams of the circuits of the 110-120 and 200-250 volt models respectively.

6.2 The wind and rewind motors have self-aligning and self-lubricating bearings; hexagon headed screws which pass through the platform engage in crescent-shaped plates, two screws to each plate and these hold the motors in position. If the screws are loosened it is possible to move the motors sufficiently to accurately centre the reel carriers in the holes in the deck casting. The brakes must be "off" when making this adjustment or when preparing to remove either the wind or rewind motor or either of the reel carriers.

6.3 A new motor should be fitted exactly as the original, i.e. the side from which the lead-out wires emerge should be facing inwards, turning a motor through 180° will affect the hum level. If the right-hand motor has been replaced or refitted, check that the drive to the counter is quite free-running, the motor develops insufficient torque to overcome any undue friction, such as might be caused by a flexible lead resting against the counter drive belt.

A slight knocking sound from the wind or rewind motor will be due to misalignment of the bearings, this is usually attributable to rough handling or to shock during transit. The defect may sometimes be cured by slightly easing off the end brackets of the motor, and then tapping the spindle gently whilst spinning the rotor by hand. When the rotor is quite free the brackets may be tightened up again. This is largely a question of proceeding by trial and error and we therefore recommend a motor with this fault be replaced without ado.

6.4 Before starting to remove the capstan motor loosen the 4-B.A. screw (see 5.2) which secures the 3-speed pinion to the motor spindle, make sure that the pinion is quite free although it cannot be taken off the spindle at this stage.

The motor is supported between the motor platform and a triangular plate K (Fig. 6) and is mounted on anti-vibration bushes, four of these are located in the platform and the fifth as shown at J (Fig. 6). Three screws, H, pass through spacers and screw into the platform.

Once these screws have been removed the motor may be withdrawn and the pinion may be slipped off the spindle as the motor is freed. Re-assembly is quite straight-forward, but it would be advisable to fit new anti-vibration bushes, in either event the bushes should be fitted to the motor before assembly and not in the holes in the platform and triangular plate.

Exercise care in refitting the 3-speed pinion on the motor spindle and check that the pinion is correctly located on the spindle relative to the idler wheel so that these two engage correctly at each setting of the speed control before finally tightening the grub screw.

6.5 The need for removing the capstan/flywheel assembly is unlikely to arise, the spindle passes through a long sleeved bearing which is part of the deck casting and it is highly improbable that any troubles will develop here.

The moulded nylon bracket shown as 12 in Fig. 1, which retains a steel ball, forms the upper thrust bearing. The lower thrust bearing consists of a steel ball located in the dimpled end of the capstan

spindle, this ball rests on a pad fitted in the thrust plug P of Fig. 6. The plug is screwed into the bracket Q and is locked in position by the nut, R.

There should be no up and down play in the bearings, but the flywheel should spin quite freely with no suggestion of stiffness. A small amount of vaseline may be applied to the thrust bearings at infrequent intervals but care should be exercised to see that no grease gets on to the capstan or the pinch roller.

6.6 Instructions for dismantling to the extent which will enable flywheel and capstan to be withdrawn have been given in Section 5.

The main sleeved bearing for the capstan is self-lubricating. A slight smear of fine oil or of vaseline may be applied to a new spindle prior to inserting it in the bearing. As the deck is, at this stage, upside down, a steel ball can be placed on the nylon bracket and, after the spindle is inserted in the main bearing its upper end may be allowed to rest on the upper thrust bearing. Loosen nut R and unscrew the thrust plug P two or three turns and ensure that the pad is in position in the plug—a little grease should hold it in position. Place a $\frac{1}{8}$ " steel ball in the dimple in the spindle end, using a spot of grease to retain it in position.

The motor platform may next be lowered into position and the securing screws inserted and partially tightened, watching to see that the spindle end, with the ball sitting in position, enters the thrust plug correctly. Check that no leads have become trapped, tighten down the securing screws and adjust the thrust plug and lock it with nut R. Insert the brake link in the hole from which it was removed earlier and bend the end over.

Refit and connect up those units which have been removed and resolder any other connections which have been broken, refit the reel carriers and the counter belt. Lace up all loose ends.

IDLER WHEEL AND SPEED CHANGE

7 The idler wheel assembly which is shown in Fig. 15 transmits motion to the capstan by engaging against the selected diameter of the drive pinion and the capstan flywheel.

The position of the idler wheel relative to the three-speed pinion is determined by a moulded cam, secured to the spindle of the speed selector by two socket grub screws. If, for any reason, these screws are disturbed they must be re-tightened in the correct order. First, fully tighten the screw which engages against the flat on the spindle and then the other to provide the required locking action. If these screws are tightened up in the wrong order there is danger that the cam will gradually become loose and fail to locate the idler wheel correctly as a result.

The moulded cam is designed to lift the idler quite clear from other parts of the mechanism when changing from one speed to another as well as when switching the machine on or off.

TAPE TENSION—WIND AND REWIND

8 Refer to Figs. 11, 12 and 13. It will be seen that when the START switch is made the capstan motor will be energised. The WIND or take-up motor will also be energised via C2 and the rewind motor will be partly energised via C2 and the paralleled resistors R1 and R2. The torque developed by the rewind motor under these conditions is sufficient only to give the required degree of back tension to the tape as it is drawn from the spool.

Depressing the FORWARD WIND key connects the WIND or take-up motor directly across the supply; at the same time R2 is disconnected, which leaves R1 in series with the rewind motor, which now provides a measure of back tension during the fast forward wind. When the REWIND key is pressed the foregoing situation is reversed.

Operation of the CUE control short-circuits resistors R1 and R2 and the wind and rewind motors are thus equally energised and develop equal torque in opposite directions, holding the tape taut and stationary.

CUE (PAUSE) CONTROL

9 The mechanics of this device are quite simple. Reference to Fig. 1 will show that lever 58 is drawn forward by operating the cue knob, 49.

A "gate" in the bracket 59, retains the lever in the open condition until the cue knob is pressed down. When the cue knob is drawn forward motion is transmitted via link 47 to the pinch wheel carrier 33. There is a degree of lost motion in link 47, the ferrule 68 being adjusted so that when the lever 58 is at the extreme limit of its travel, the pinch wheel is only just clear of the capstan.

Simultaneously, the micro-switch S6 of Fig. 11 closes and, as stated in Section 8, the WIND and REWIND motors are equally energised and the tape is thus held stationary and taut and is drawn clear of the capstan by the tape guide 28.

S6 is mounted on the underside of the deck and is actuated by a peg which extends downwards from lever 58 through a hole in the deck.

AUTO-STOP

10 The AUTO-STOP assembly consists of the tape guide 14 Fig. 1, beneath which is mounted a micro-switch—S2 of Fig. 11. This switch is actuated by the small lever 24 (Fig. 1) and is biased to break, but it is held in the make condition by the tape passing between lever 24 and tape guide 14. The lever M of Fig. 6, besides actuating the brake mechanism, also holds the micro-switch S2 in the "make" position when all the keys are up, thus enabling the tape to be loaded correctly.

The lever, M, besides pulling off the brakes when either the START, WIND or REWIND key is depressed also releases lever 24, and if the tape has been loaded incorrectly the AUTO-STOP will function immediately any one of these three keys is operated.

When the end of the tape has passed through the AUTO-STOP, lever 24 will travel its full extent, the switch will open and power will be cut from the motors which will slowly come to rest. The brakes will not be applied nor will the pinch wheel be retracted from the capstan till the STOP key is pressed.

REMOVAL OF AUTO-STOP:—

Depress the START key, remove screws a and a¹ (Fig. 1) and carefully lift the assembly clear of the deck, disconnect the leads to the switch and re-connect to the replacement. When fitting new assembly, see that the START key is down and take care to see that lever 24 is in front of lever M (of Fig. 6) and before finally tightening screws a and a¹ ensure that the lever 24 moves freely to the "make" position when the STOP key is pressed and that it rests against the tape when any one of the three keys controlling tape transport is operated.

SWITCHES

11.1 TAPE SPEED SELECTOR:—

The wafer switches associated with the equalisation circuits of the record and play amplifiers are operated by this control, so too, is the mains switch S20/S21 of Fig. 6. The Idler Wheel assembly is operated by this control.

11.2 PIANO-KEY SWITCH:—

The START, FAST FORWARD and REWIND keys operate the switches S3, S4 and S5 of Fig. 11 respectively. The failure of any one of these switches to function correctly will result in incorrect operation of one of the motors and this fault will be due to distortion of the relevant plunger or to failure in the micro-switch concerned. If the former, the fault should not be difficult to rectify in situ.

If the machine is in the RECORD mode, pressing either the fast WIND or REWIND key will automatically return it to the PLAY condition. The STOP key will also do this even if the tape has not been put in motion.

11.3 RECORD/PLAY CONTROL:—

This control operates a wafer-type switch in the D.C. supply to the record amplifier and bias oscillator circuits. Although it has no other electrical function it provides a measure of protection against erasure of recorded material which might otherwise occur accidentally.

The control will normally be set to PLAY, being biased by a spring to take up this position from which it cannot be turned to RECORD until the RECORD key is operated which lifts the interlock lever 50 of Fig. 1. This permits the RECORD/PLAY control, with the lever 61 attached to its spindle, to be turned in a clockwise direction. When lever 61 has passed under the two interlock levers 50 and 60 the latter will lock the lever 61 to prevent the control being returned (by the tension of the biasing spring) to the PLAY position. Depressing any key other than START will lift the interlock lever 60, free lever 61 and the control will revert to the PLAY position.

CIRCUIT NOTES

12.1 Reference to the circuit diagram will show that material may be fed to the machine for recording, either at the MICROPHONE socket or at the RADIO/P.U. socket, or at both simultaneously, each input having its own gain control so that it is possible to mix two programmes.

With the three-head configuration and separate record and play pre-amplifiers of the 100 Series one is able to monitor the recording as it progresses in the certain knowledge that what is heard on this occasion is also what will be heard from subsequent playings.

If a recording made on the machine appears distorted check that the PLAY pre-amplifiers (and the power amplifier in the case of a Recorder) reproduce satisfactorily from a recorded tape of known quality. If this test shows that the fault is in the recording section of the machine it will most likely be found in the bias oscillator circuits.

12.2 The drawings of the printed circuit boards show the location of the board-mounted components and the printed wiring on the underside of the boards is shown by hatching, so that one views a board as though it was semi-transparent. The terminal points on the boards are numbered on the component side and these numbers are shown at the appropriate points on the circuit diagram. Voltage tests are thus easily carried out and the identification of components is also easy but care must be taken during tests. The voltages to be expected at various points in the circuit are indicated in the circuit diagram.

12.3 The input signal at the MICROPHONE socket is amplified by VT5 which is a low-noise transistor, the gain of which is set at a pre-determined level by the adjustment of R28. The output of this stage is taken via the MICROPHONE gain control, R29, to the base of VT6 to which point any input at the RADIO/P.U. socket will also be fed via R47, its manual gain control. The output from the emitter of VT6 takes two parallel paths, one to the base of VT7, the other to the base of VT9. Amplified by VT7, the signal passes to the base of VT8, the output at its collector being taken to the record head. The frequency characteristic of the feedback circuit between the collector of VT8 and the emitter of VT7 is designed to provide high-frequency pre-emphasis over a given band of frequencies appropriate to the tape speed. Switch 7, operated by the speed control, selects the required value of capacitance.

As stated above, the output from the emitter of VT6 is taken to the base of VT9. After amplification by VT9 and VT10 the signal again takes two paths, one to S2, the other to the base of VT11. When S2 is set to SOURCE (in a Recorder) or to the appropriate channel (in a PD model) the amplified input signal is fed to the base of VT4, finally appearing at the output socket of the PLAY pre-amplifier.

The signal applied at the base of VT11 is reproduced across R56 and so actuates the VU meter.

12.4 Equalisation characteristics are governed by the negative feed-back circuit between the collector of VT3 and the emitter of VT2 in the PLAY pre-amplifier. The tape, having passed across erase and record heads, whether inert or energised, finally passes across the play head and the magnetic pattern on the tape induces currents in the play head circuit, the potentials so produced are applied via C1 to the base of VT1. This is a low-noise transistor, the gain of which is set at a pre-determined level by adjusting R5. Further amplification is effected by VT2 and VT3 and the time constant of the feed-back equalisation circuit between VT2 and VT3 depends on the value of resistance selected by S1, which, being ganged to S7, depends upon the setting of the speed control.

When S2 is set to TAPE (or the relevant channel MONITOR button "up" in a PD model) the signal is impressed at the base of VT4 which, acting as an emitter follower, provides a low impedance output at Socket 2.

12.5 In the Recorders, unless a plug is inserted in Socket 2, the signal is fed to the base of VT14, the input stage of the power amplifier. The feed-back circuit between the L.S. output socket SKT.5 and the emitter of VT14 has a variable control which permits of some variation of tonal quality.

An external loudspeaker can be connected to SKT.5. This will silence the internal speaker of the Recorder.

In both Recorders and PD models, the signal available at SKT.2 will be at a suitable level to feed to an external amplifier, such as TRUVOX TSA.100, at a sufficiently low impedance to allow the use of fairly long inter-connecting cables.

12.6 It will be understood that although these remarks have not yet made the point, the D.C. supply to the record preamp and the bias oscillator must be cut off except when recording. A switch, S22, operated by the master PLAY/RECORD control performs this function in the R102 and R104.

In the PD models there is in addition to the master switch S22, two push-button switch assemblies marked RECORD, and these control the D.C. supply to the associated record preamps and meter amplifiers via S9 and S12 for the Left and Right channels respectively. Supply to the bias oscillator is controlled by S9 (Left channel) or S10 (Right channel). The Left channel assembly also includes S8, S14, S15 and S16. The Right channel assembly includes S13, S17, S18 and S19.

S8 and S13 switch the pilot bulbs B2 and B3 respectively which indicate that that channel is in the record mode. S16 and S17 switch the erase head circuits while S15 and S18 switch the bias to the record heads.

12.7 P.D. Models only

The physical location of the various switches comprising the RECORD press-button switch assemblies is not quite as suggested by the circuit diagram and a more practical view of these switches with the associated circuitry will be found in Fig. 8. Given certain tolerance combinations erasure may occur on one track while recording on the other. In such an event compare the machine with Fig. 8. Remove C53 and C54 and the links shown by the dotted lines and provide new links, as shown by the broken lines in the drawing—refer to Note 4 in Fig. 8.

12.8 RECORDERS only

Two types of power pack have been fitted in these machines, one may be seen in Fig. 14a, the other in Fig. 14b; both are shown in the circuit diagram, Fig. 16. Where the unit of Fig. 14a is incorporated a filter is added in parallel with the Loud-speaker. This filter, not shown in Fig. 16, consists of a 12 ohm resistor in series with a 1 mfd capacitor. The power pack of Fig. 14b has a source of D.C. for the power amplifier that is independent of the supply to the pre-amps and bias oscillator and in these circumstances the filter is superfluous.

Some early production models, fitted with the power pack of Fig. 14a did not have this filter. If, with age, instability is experienced in a machine of this type, a filter should be made up and fitted.

TEST PROCEDURE

13.1 In the event of failure, subject all components to visual scrutiny for signs of over-heating and examine the underside of printed circuit boards for fused or burned-out conductors, having previously made sure that the fuse is in order and of the correct rating.

13.2 Recorders only:—Power Amplifier

Connect a 15 ohm 5-watt non-inductive resistor across the output in place of the loud-speaker. Inject a 1,000 cps signal via a capacitor between point 47 and the earth line.

Adjust input signal level and R71 to give maximum sine-wave output with symmetrical clipping on peaks.

Reduce signal level until clipping ceases and note that the output wave-form is not distorted.

13.3 Recorders only:—Erase and Bias Oscillator

Connect a 22K. ohm .5-watt resistor between points 29 and 30 on the oscillator printed circuit board. With the machine switched on and the Master Control in the Record mode and with the 'scope connected across the load resistor, check that the circuit is working and the wave-form undistorted.

Depress S23 (NOT R104D) and check that oscillations are maintained.

Remove load resistor and 'scope.

Connect valve-voltmeter between lead-through 4 of Fig. 1 and earth, note that the potential across the erase head exceeds 50V RMS.

Transfer valve-voltmeter to lead-through 5 of Fig. 1 and adjust C33 (which is adjacent to VT12 and VT13 of Fig. 6) to give a minimum of 25V RMS across the record head. Operate the track switches (NOT R102) and verify that the bias volts do not vary by more than 3 dB.

P.D. Units:—See 13.7

13.4 Record and Meter Amplifier:—All Models

(a) Set MIC and RADIO gain controls to maximum (fully clockwise), turn Master Control to Record, inject a 1,000 cps signal at the MIC socket; with the input signal level set to 0.5mV, adjust R28 to give a reading of 0 dB on the VU meter. Transfer signal generator to Radio socket and check that the input level required to give a reading of 0 dB on the VU meter does not exceed 50mV.

Switch S2 to SOURCE and verify that the output at SKT.2 is not less than 1 volt.

(b) Equalisation:—To check the equalisation of the Record amplifier, connect valve-voltmeter and 'scope between point 14 and earth. Reduce the signal input at 1 Kc/s to give a reading of -10 dB on the VU meter and note the resultant reading on the valve-voltmeter.

(c) Vary the input frequency as follows:—

Between 17-20 Kc/s with Speed Control set to $7\frac{1}{2}$ ips

Between 10-13 Kc/s with Speed Control set to $3\frac{3}{4}$ ips

Between 6-10 Kc/s with Speed Control set to $1\frac{7}{8}$ ips

At these frequencies an increase in gain of 12 to 16 dB's (referred to the level noted at (b) above) is to be expected.

(d) Some modification to the fore-going is necessary in the case of PD units—in addition to setting the Master Control to Record, the press switch marked RECORD will have to be operated on the track which is to be tested and the tests described in this sub-Section and those in the following sub-Section will have to be applied to each channel.

This should present no difficulty as, with obvious exceptions, the component references, etc., are the same for both types of machine.

13.5 Replay Amplifiers

(a) With the machine still in the Record mode, inject a signal of 1 Kc/s and adjust the input level and gain control to give a reading of -10 dB on the VU meter. With R7 (Volume Control) at

maximum, set S2 to SOURCE and measure (and note) the output voltage at SKT.2 registered by valve-voltmeter.

- (b) Record and replay this 1 Kc/s signal with R7 at maximum. Set S2 to TAPE and while playing this recording, adjust R5 to give the same output as was obtained under the conditions of 13.5 (a).
- (c) Equalisation:— With input signal frequency of 1 Kc/s and recording level -10 dB on VU meter commence recording at the same time varying the frequency of the input signal as follows:—
 - From 40 c/s to 17 Kc/s at a tape speed of $7\frac{1}{2}$ ips
 - From 40 c/s to 10 Kc/s at a tape speed of $3\frac{3}{4}$ ips
 - From 60 c/s to 5 Kc/s at a tape speed of $1\frac{7}{8}$ ips

The output at SKT.2 should, on replay, be level ± 3 dB, relative to the output at 1 Kc/s, at each tape speed.

Slight adjustment of C33 is permissible if the H.F. response at $7\frac{1}{2}$ needs correction.

- (d) In PD Units, C33 and C36 may be trimmed to bring the H.F. response of the two channels in line at $7\frac{1}{2}$ ips. Care should be taken to ensure that adequate bias is maintained.

13.6 Signal to Noise Ratio:—

RECORDERS:—

- (a) Record a 1 Kc/s signal via MIC socket at 0 dB level on VU meter.
- (b) With 15 ohm resistor in place of loud-speaker, play this recording with the volume control at maximum. Measure the output across the load resistor.
- (c) Play an un-recorded tape and note the noise level across the load. Compare this with the output noted at (b). The mains transformer may be rotated to reduce any hum content in the residual noise level and this should be done with the motors running and with no tape loaded.
- (d) Signal to noise ratio should be better than 42 dB.

P.D. UNITS:—

- (e) Follow the procedure given above, taking the required measurements at the output sockets. Any alteration in the orientation of the mains transformer should be directed towards producing an equal level of hum on each channel. The signal to noise ratio should be at least 40 dB on each channel.

13.7 P.D. UNITS—Erase and Bias Oscillator:—

- (a) In the first instance, examine the machine to ascertain that it is in accord with the Circuit Diagram and the remarks in Section 12.7; if C53 and C54 are present the necessary modifications should be effected before proceeding with any tests.
- (b) Refer to Fig. 2 and with the Master Control in the Record position, depress the two press switches marked "RECORD". Measure the potential across the two erase head windings at lead-throughs a and c, note that valve-voltmeter readings are as given in the table at (e). Release Left channel RECORD button and note that the voltage across the Right erase winding rises as shown at (e). Depress the Left channel RECORD button, release the Right. Confirm that the Left channel erase voltage is as quoted in the table.
- (c) Depress the RECORD buttons and adjust C33 and C34 to give readings at lead-throughs e and g as shown at (f). Release one button and check that the bias changes by approximately 1 dB across the head winding of the channel still on RECORD—repeat with the alternative channel.
- (d) As mentioned in 13.5 (d), some difference in bias potential between one channel and another is permissible as a means of obtaining uniform H.F. response; it is advisable to increase the bias across one winding rather than to lower the potential across the other. Although this may not give the optimum response at frequencies in the region of 17 Kc/s, it will not entail any significant loss of H.F. response. In this way tape hiss will be kept to a minimum.

- (e) Erase voltages:—
 - P.D.102—Both channels on Record53V
 - One channel on Record55V
 - P.D.104—Both channels on Record59V
 - One channel on Record60V
- (f) Bias voltages:—
 - P.D.102—Both channels on Record36V
 - One channel on Record35V
 - P.D.104—Both channels on Record26V
 - One channel on Record25V
- (g) Divergencies of less than ± 3 dB are not significant.

LEGEND FOR FIGURE 1

- | | | |
|-------------------------------|---------------------------------|---|
| 1 Reel Carriers | 25 Tape Guide | 52 Bracket |
| 2 Hublocks | 26 Tape Guide | 53 Cam Operating 43 |
| 3 Lead-through | 27 Tape Guide | 54 Deleted |
| 4 Lead-through | 28 Tape Guide | 55 Locator Arm |
| 5 Lead-through | 29 Pressure Pad Lever—Erase | 56 Leaf Spring |
| 5 Lead-through | 30 Pressure Pad—Erase | 57 Adjustment Plate |
| 6 Lead-through | 31 Pressure Pad—Record | 58 Cue Control Lever |
| 7 R102/4—Erase Switch | 32 Capstan Flywheel | 59 Cue Control Bracket |
| 8 R104D—Track Switch 1 & 4 | 33 Pinch Wheel Lever | 60 Interlock Lever |
| 8 R102/4—Track Switch 1 & 4 | 34 Pivot Screw | 61 Master Control Lever |
| 8 R104D—Track Switch 2 & 3 | 35 Pressure Pad Lever—Record | 62 Hairpin Spring |
| 9 R102/4—Track Switch 2 & 3 | Head | 63 Spring |
| 9 R104D—Duo-Play Switch | 36 Pressure Pad Lever—Play Head | 64 Bearing Post for 55 and 72 |
| 10 Lead-through | 37 Pressure Pad—Play Head | 65 Bearing Post for 58 |
| 11 Lead-through | 38 Pressure Pad Lever Mounting | 66 Counter Re-set |
| 12 Upper Thrust Bearing | 39 Spacer | 67 Master Control—Index Plate |
| 13 Piano Control Switch | 40 Pinch Wheel | 68 Adjustment for 47 |
| 14 Tape Guide | 41 Pivot for 33 | 69 Digital Counter |
| 15 Screw—Securing Erase Head | 42 Link | 70 Screws Securing Bracket |
| 16 Screw—Securing Record Head | 43 Pressure Pad Assembly Lever | 71 Finger Grip |
| 17 Screw—Record Head Height | 44 Tension Springs (3—off) | 72 Adjustment Plate |
| 18 Screw—Record Head Azimuth | 45 Control Link | 73 Locking Screw |
| 19 Screw—Securing Play Head | 46 Cam | 74 Adjustment Screw |
| 20 Screw—Play Head Height* | 47 Link | 86 Screw Securing Head Assembly |
| 21 Screw—Play Head Azimuth | 48 Tension Spring | 87 Screw Securing Head Assembly |
| 22 Capstan | 49 Pause Control Knob | a Screw Securing Auto-Stop |
| 23 Tape Guide | 50 Interlock Lever | a ¹ Screw Securing Auto-Stop |
| 24 Auto-Stop Lever | 51 Spring | |

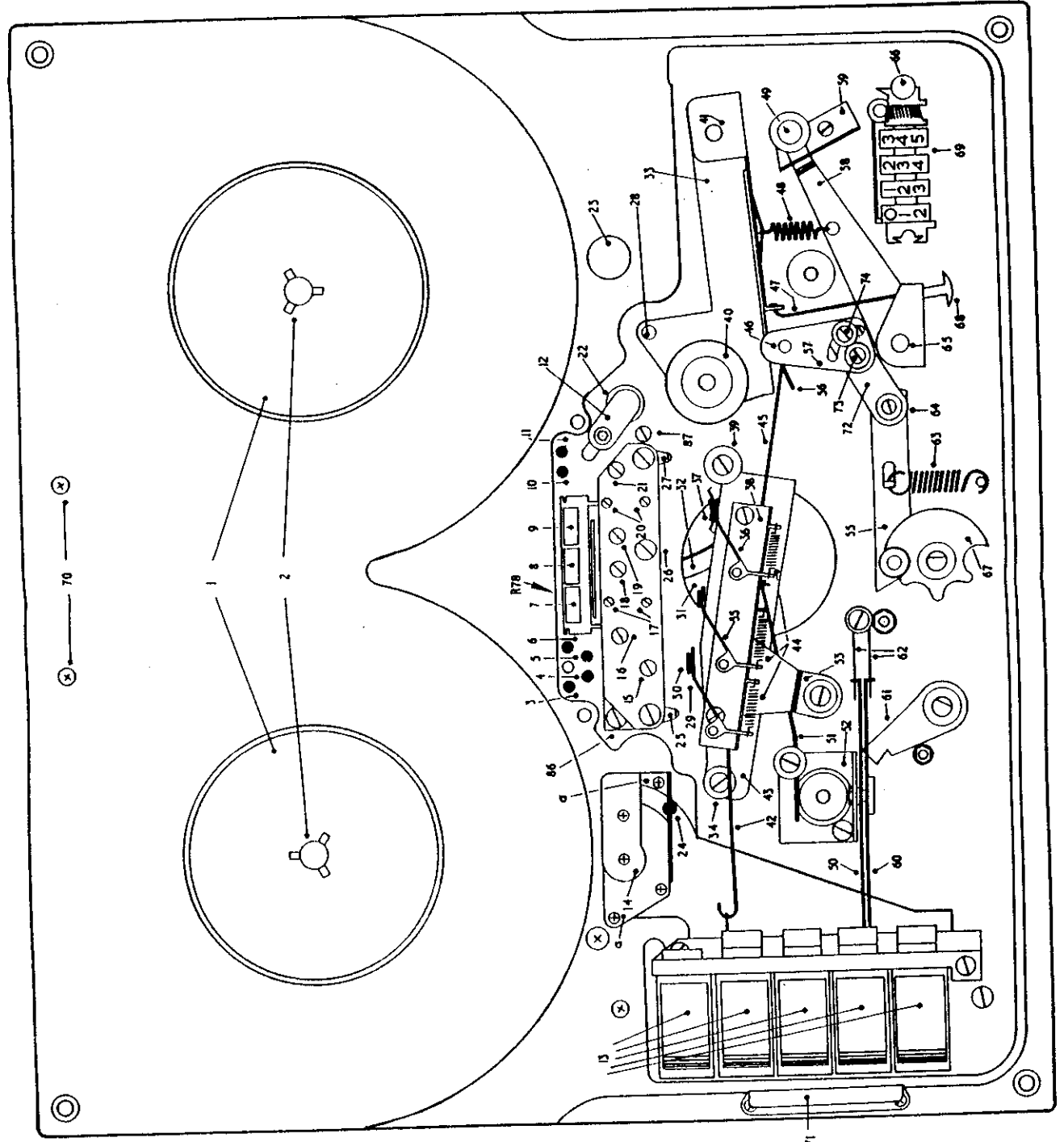

FIG. 1

a b c d e f g h i j k

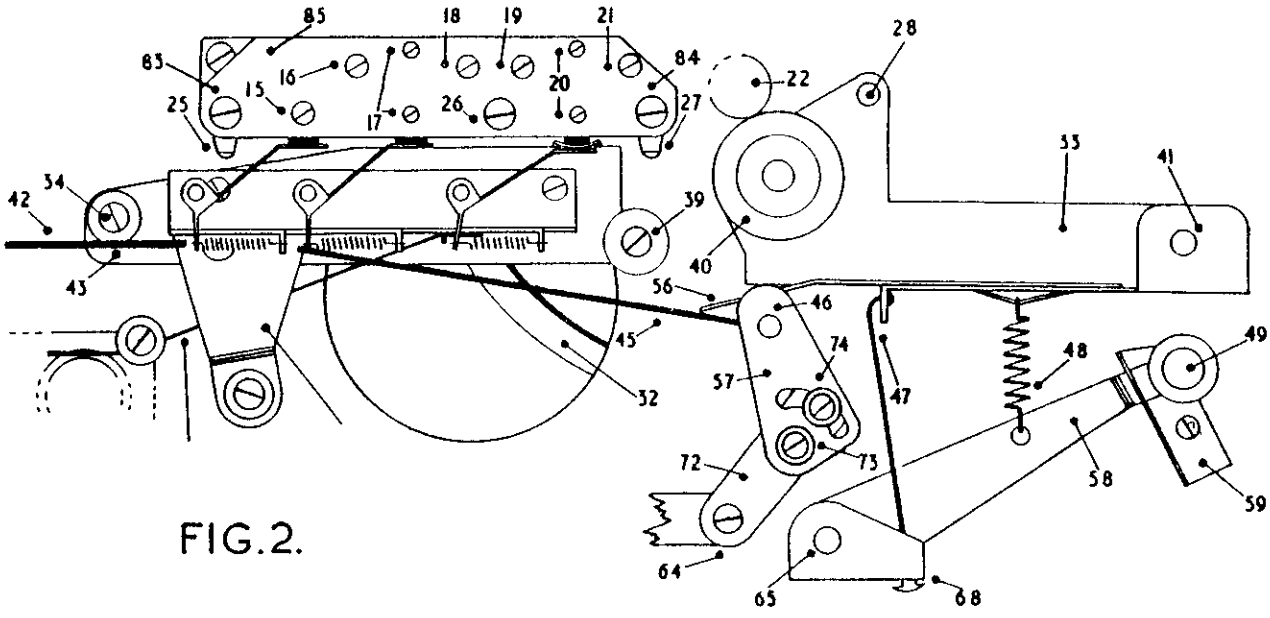

FIG. 2.

References as
in FIG. 1.

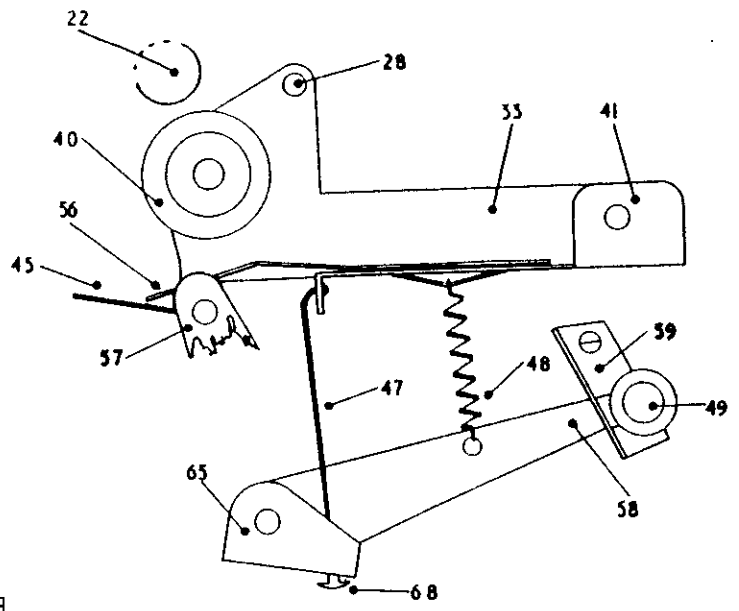

FIG. 3.

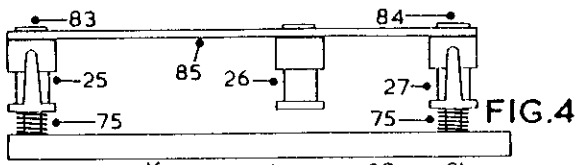

FIG. 4

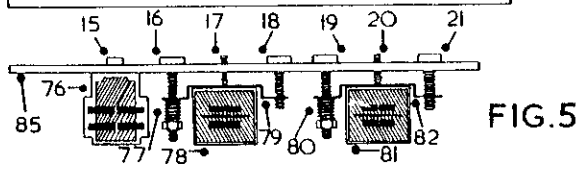

FIG. 5

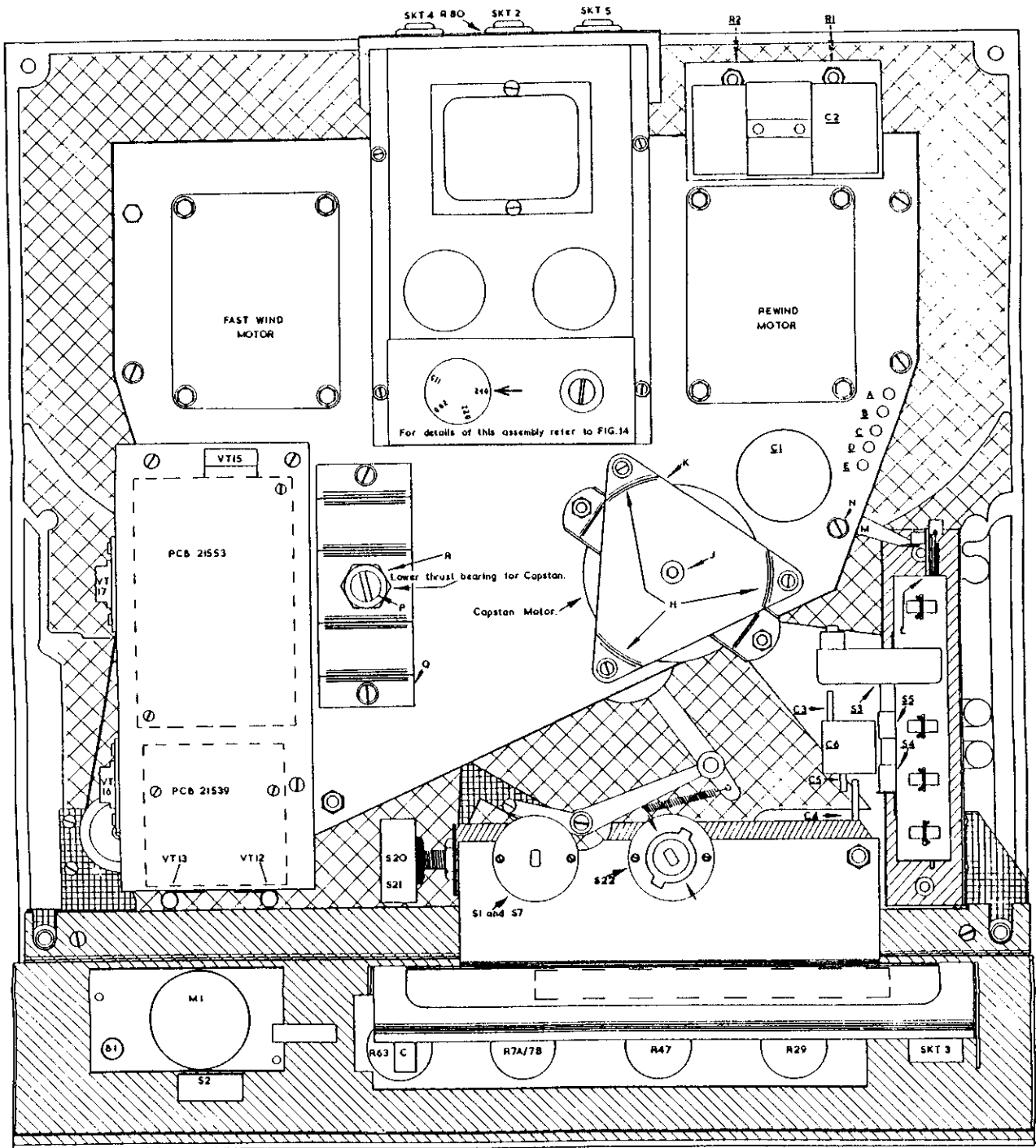
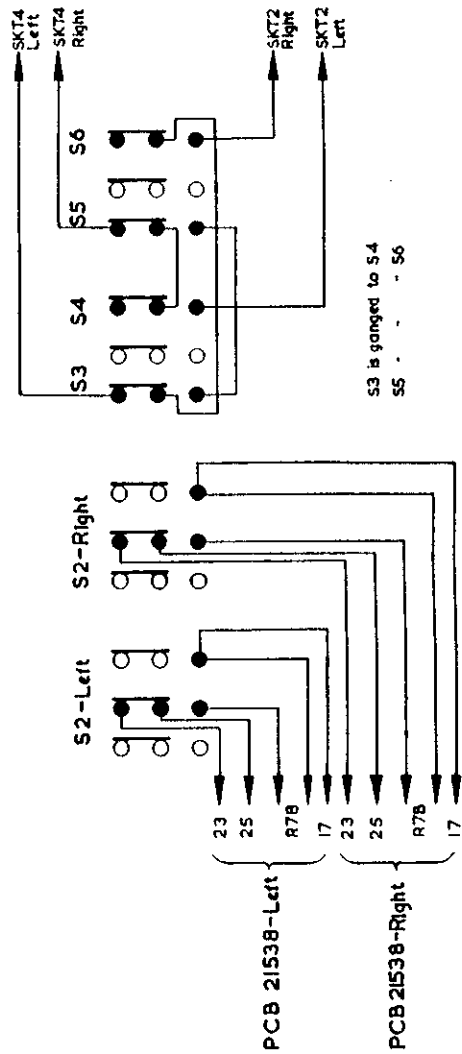
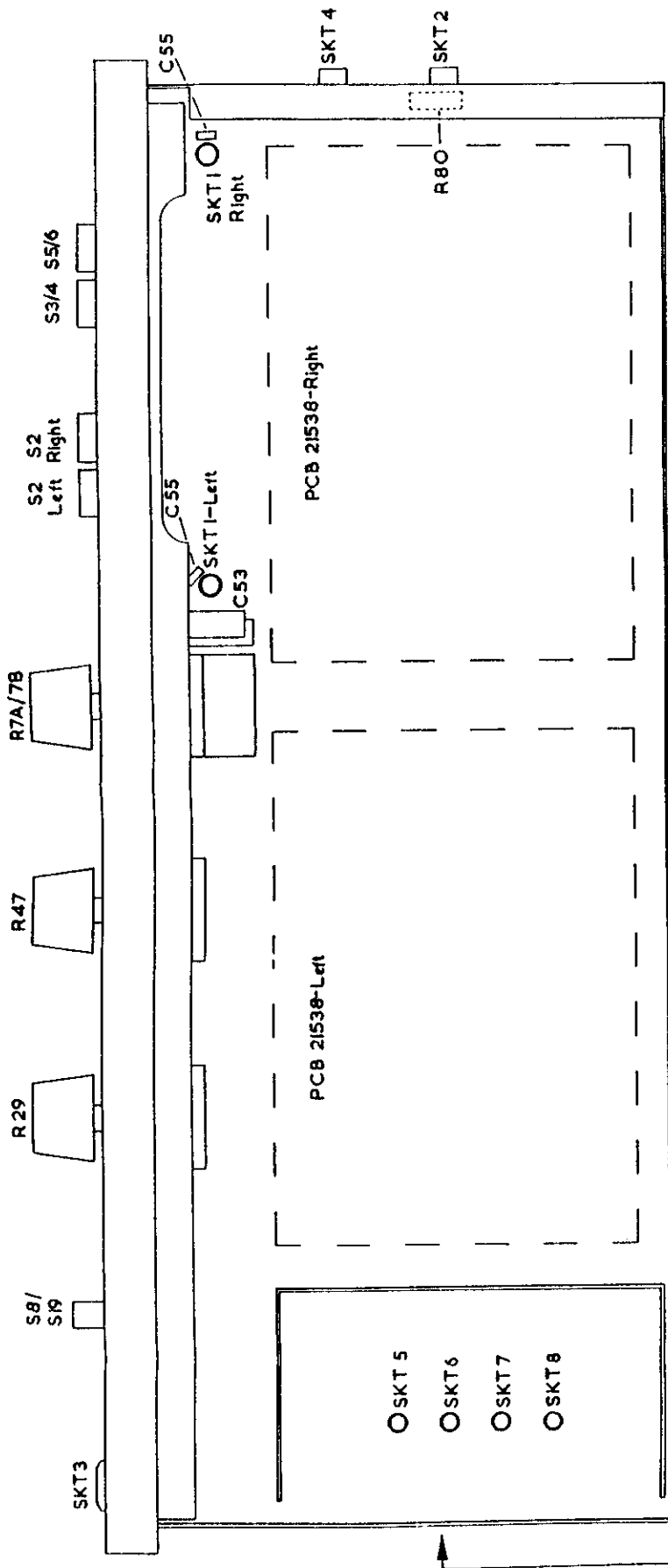

FIG. 6

S1/7, S20, S21, S22 are fitted as shown in PD units as well as in Recorders.
 In PD units S1/7 has two wipers, the wiper nearest the knob is in the Right amplifier.
 Other divergencies are dealt with in the text.

Items underlined thus: C2, refer to FIGs II 12 and 13.



See FIG 8 for wiring of switches S8 to S19 inclusive.

FIG.7

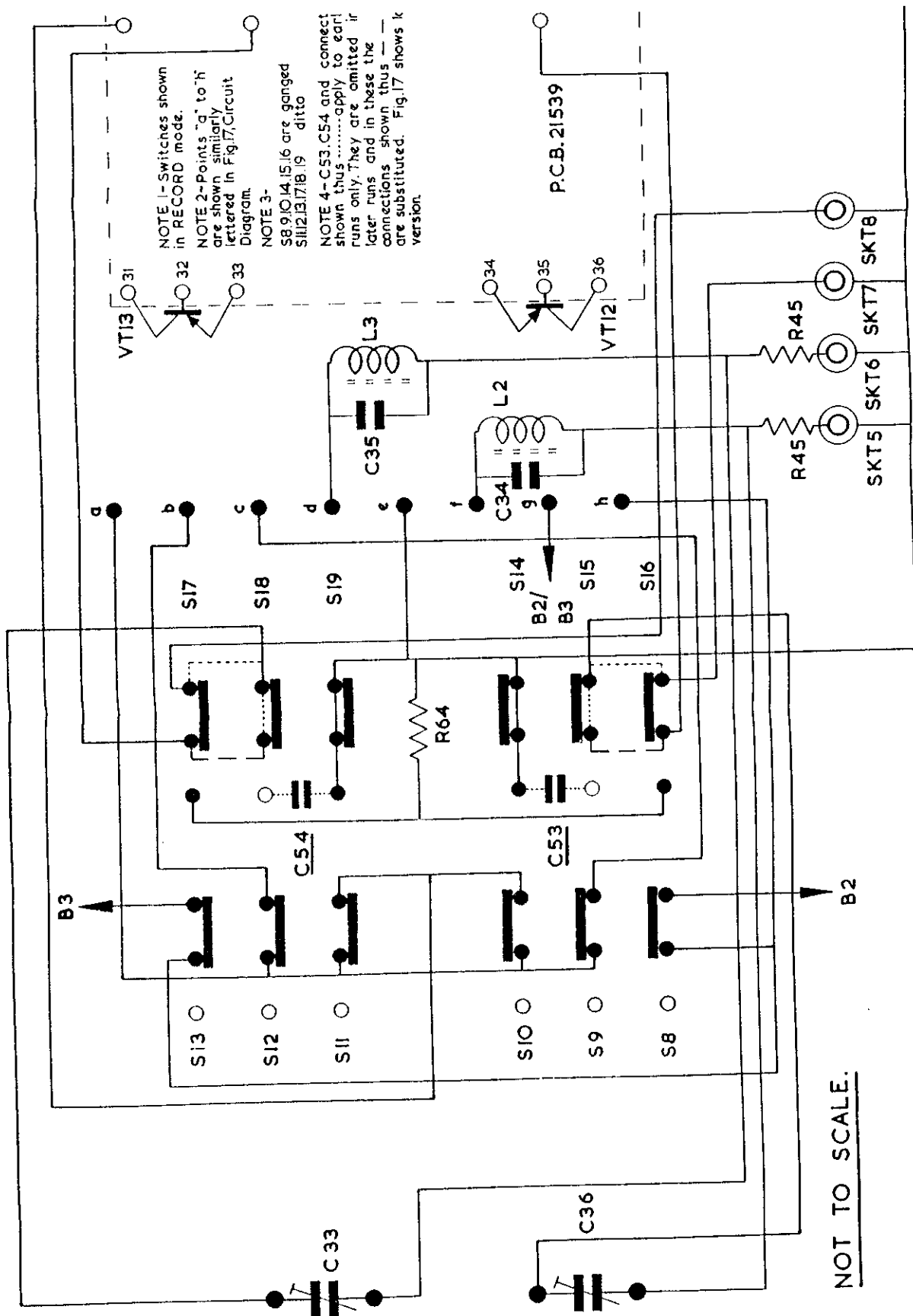

NOTE 1- Switches shown in RECORD mode.

NOTE 2- Points "a" to "h" are shown similarly lettered in Fig.17,Circuit Diagram.

NOTE 3- S8,9,10,14,15,16 are ganged S11,12,13,17,18,19 ditto

NOTE 4- C53, C54 and connect shown thus.....apply to earl runs only. They are omitted in later runs and in these the connections shown thus --- are substituted. Fig.17 shows k version.

P.C.B. 21539

NOT TO SCALE.

FIG.8

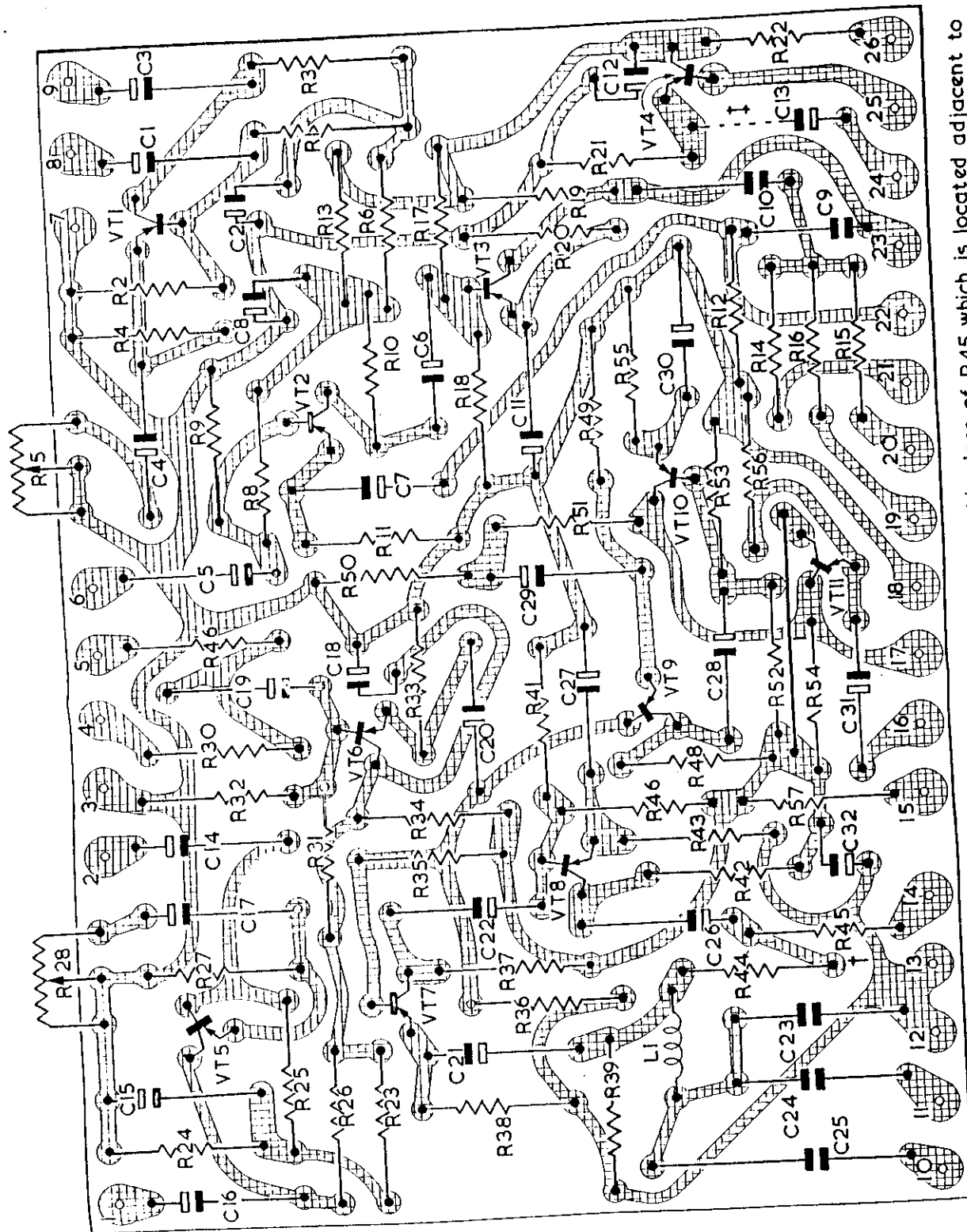

P.C. Board 21538

† In PD models a shorting link is fitted in place of R45 which is located adjacent to Skt 5(left) or Skt 6(right).

‡ R82 is inserted here in series with CI3 in PD models.

FIG.9

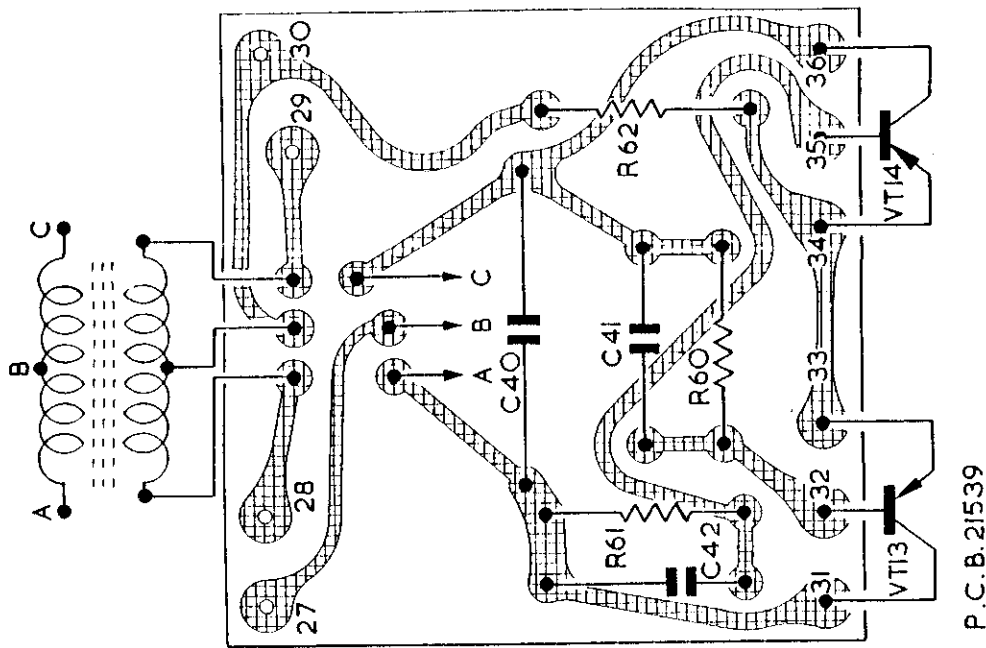
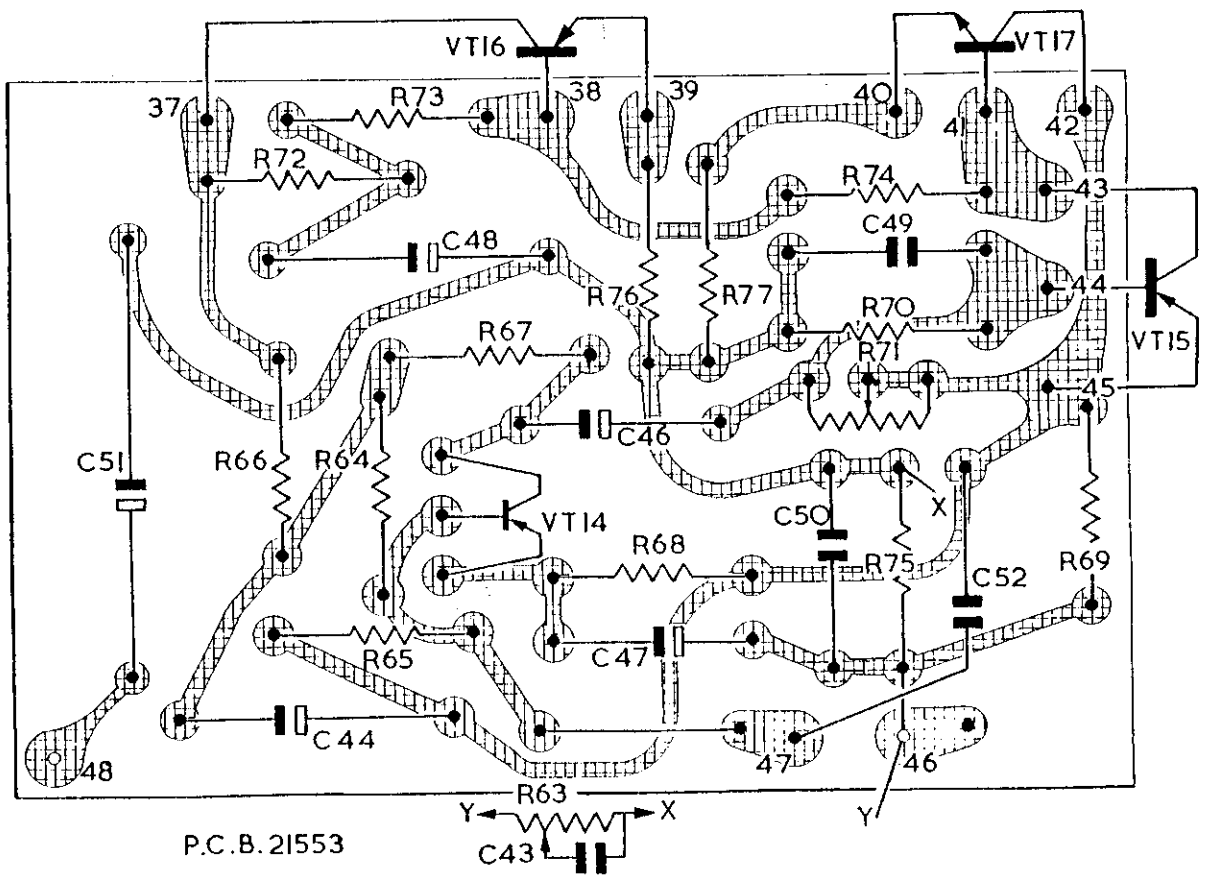

FIG.10



Motor Connections:—

200/250 volt — — — —

100/125 · · · · ·

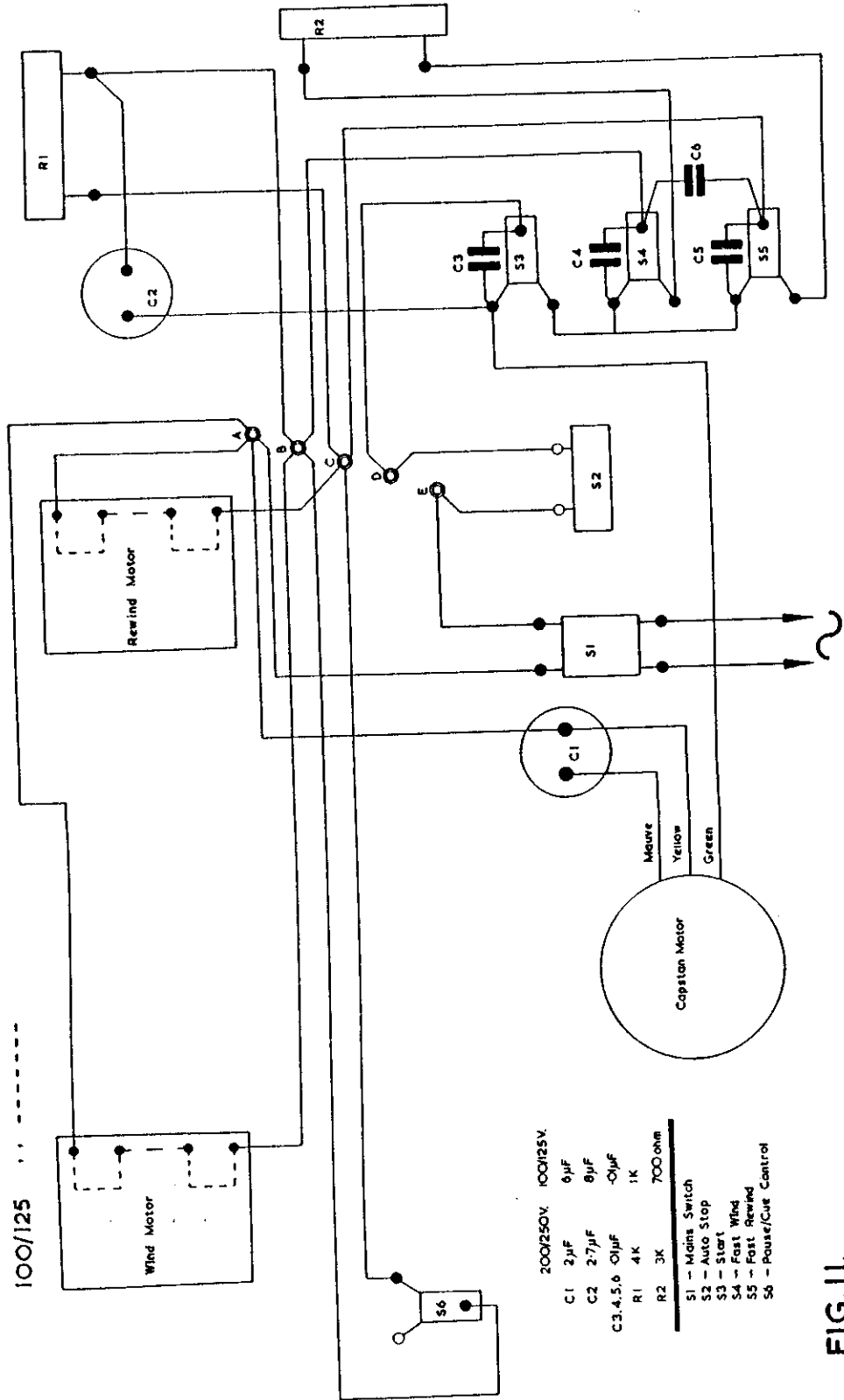

- | | |
|--------------|----------|
| 200/250V | 100/125V |
| C1 2µF | 6µF |
| C2 2.7µF | 9µF |
| C3,4,5,6 0µF | 0µF |
| R1 4K | 1K |
| R2 3K | 700 ohm |
-
- | | |
|----|---------------------|
| S1 | — Mains Switch |
| S2 | — Auto Stop |
| S3 | — Start |
| S4 | — Fast Wind |
| S5 | — Fast Rewind |
| S6 | — Pause/Cue Control |

FIG. 11.

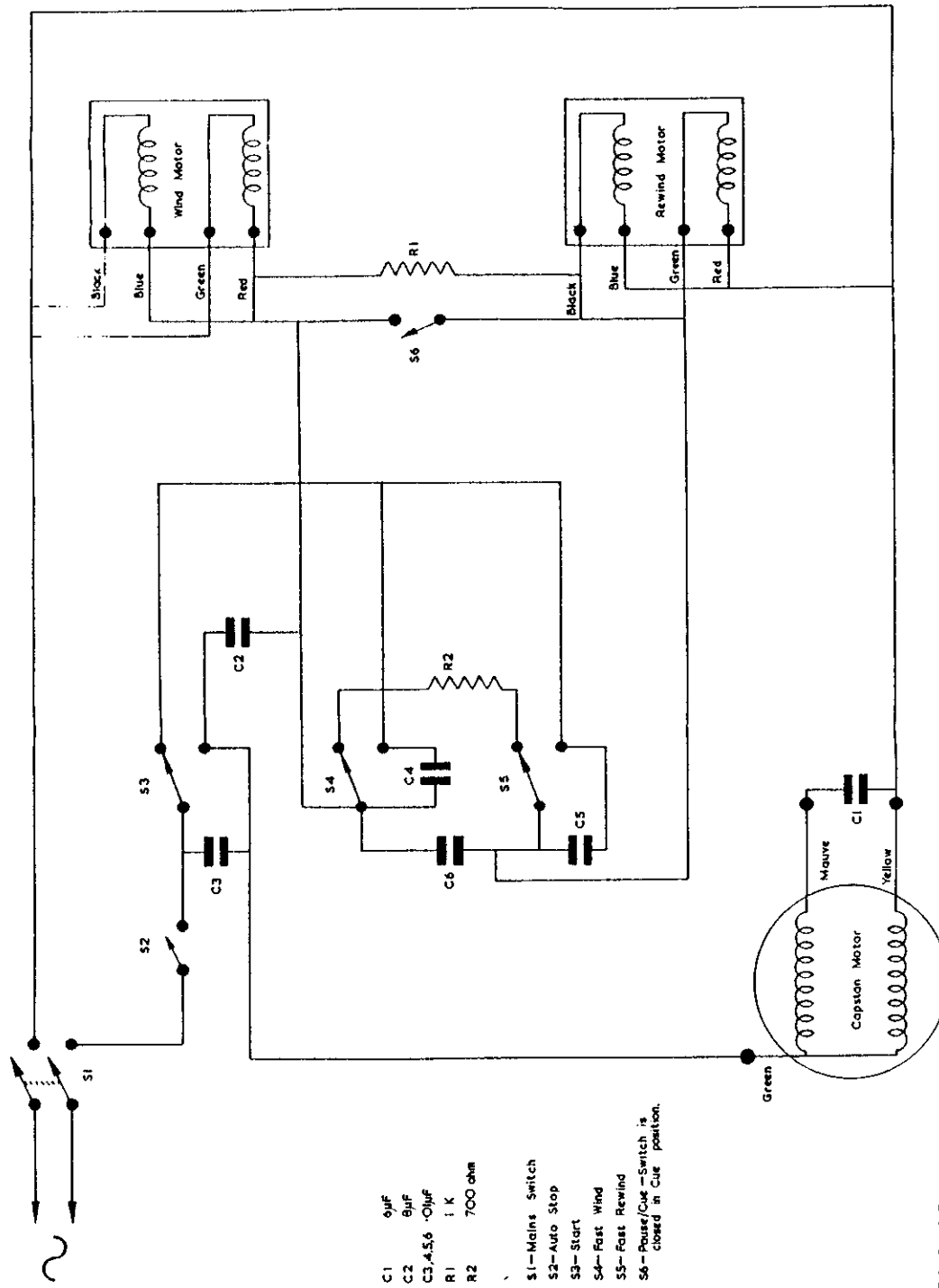

FIG. 12

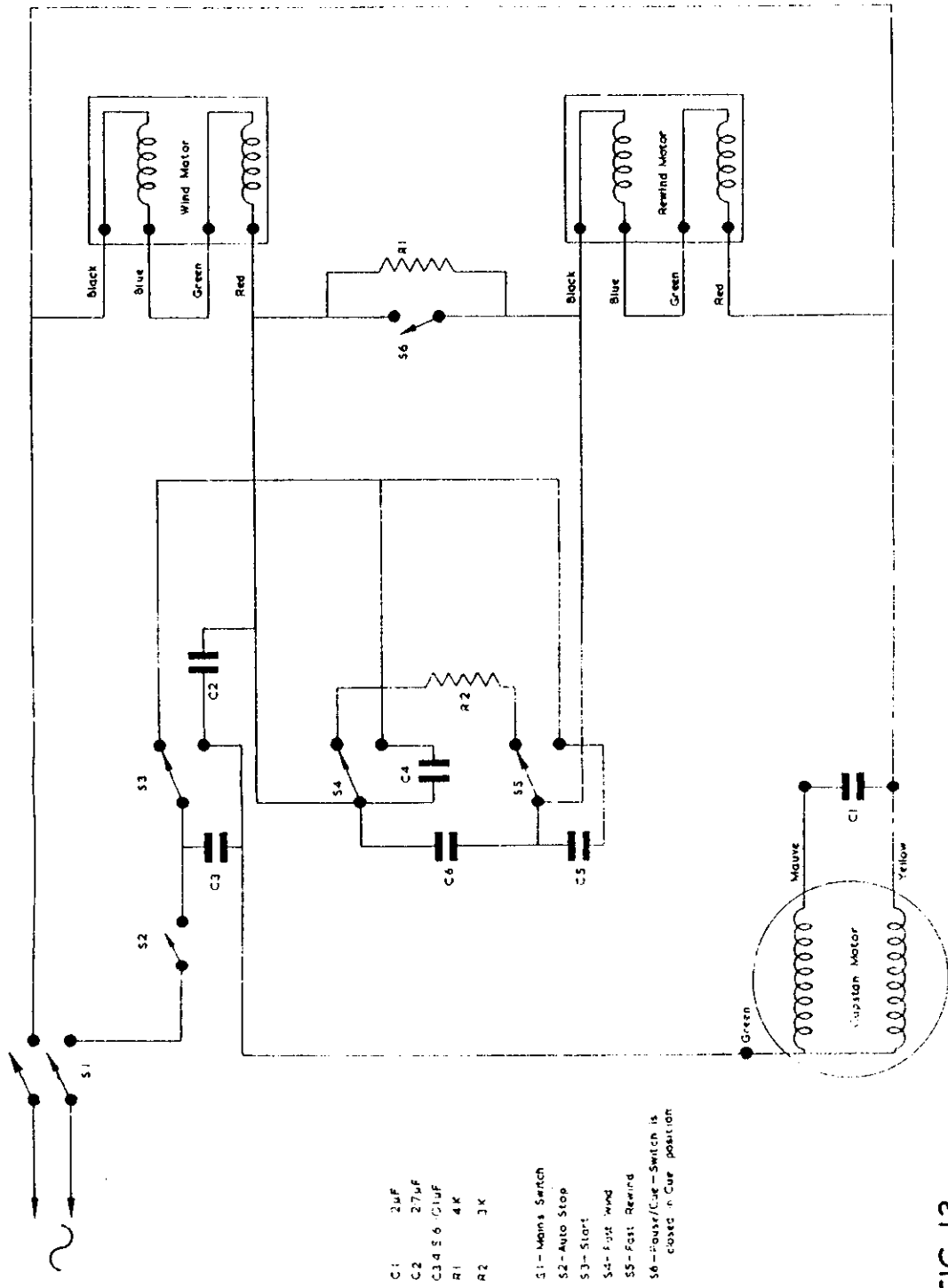

FIG.13

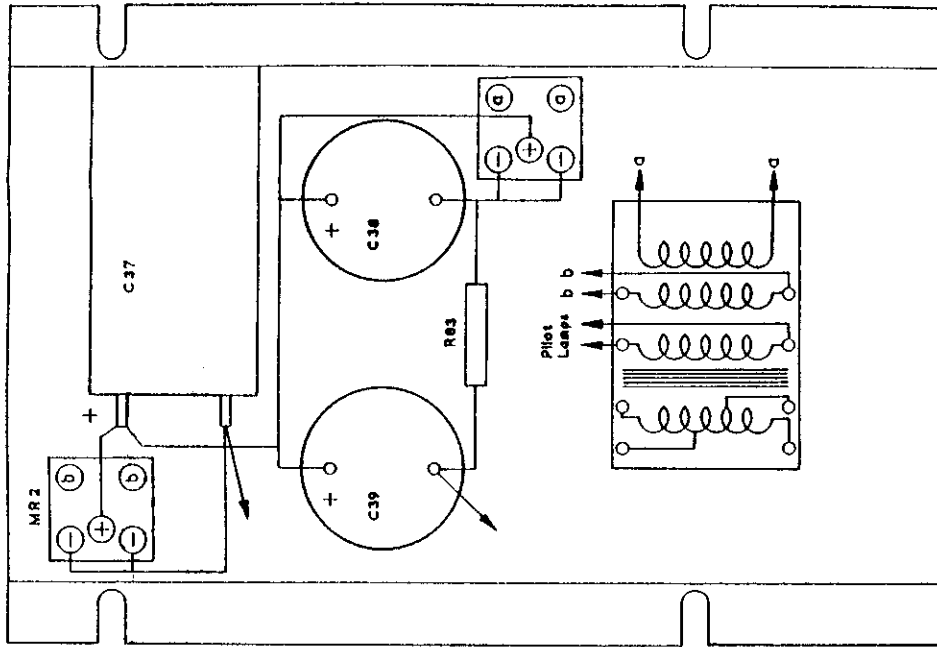

FIG. 14b

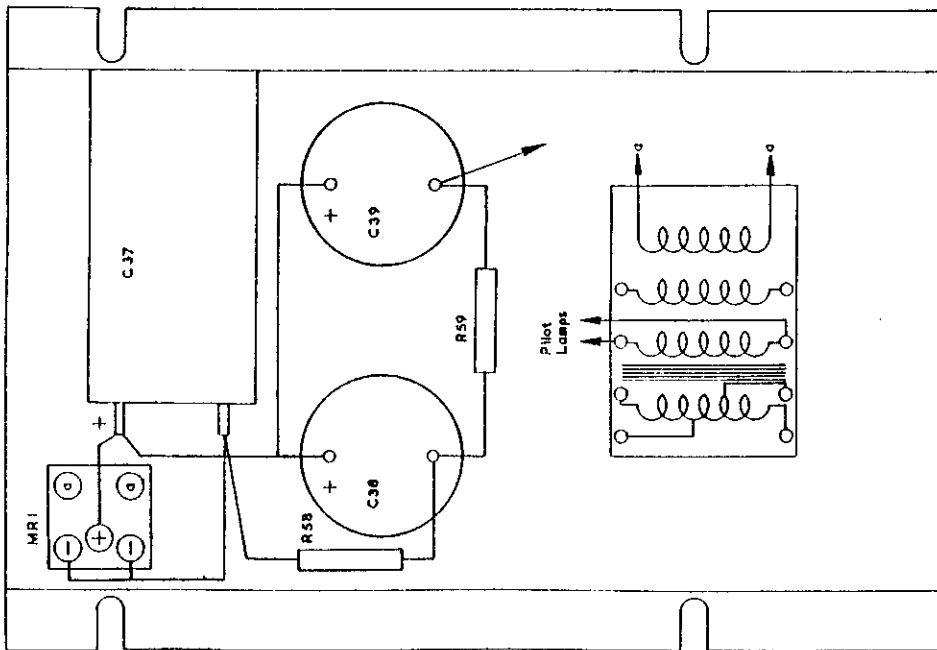

FIG. 14a

LEGEND FOR FIGURE 16

R1	220K H.S.	R66	2.2K	C1	12.5 Mfd	C27	50 Mfd
R2	47K H.S.	R67	4.7K	C2	32 Mfd	C28	12.5 Mfd
R3	33K H.S.	R68	2.2K	C3	12.5 Mfd	C29	50 Mfd
R4	10K H.S.	R69	100 ohms	C4	50 Mfd	C30	50 Mfd
R5	22K Pre-set	R70	47K	C5	12.5 Mfd	C31	12.5 Mfd
R6	22K	R71	2K Pot	C6	12.5 Mfd	C32	32 Mfd
R7A	25K } Changed	R72	180 ohms	C7	50 Mfd	C33	10-60 pf
R7B	25K }	R73	470 ohms	C8	50 Mfd	C34	PD Units only
R8	150K	R74	12 ohms	C9	470 pf	C35	" " "
R9	39K	R75	680 ohms	C10	.01 Mfd	C36	1000 Mfd
R10	22K	R76	2.2K	C11	50 Mfd	C37	1000 Mfd
R11	10K	R77	2.2K	C12	32 Mfd	C38	1000 Mfd
R12	220 ohm	R78	2.2K	C13	12.5 Mfd	C39	1000 Mfd
R13	39K	R79	22K	C14	12.5 Mfd	C40	.01 Mfd
R14	27K	R80	47K	C15	50 Mfd	C41	.001 Mfd
R15	10K	R81	1K	C16	12.5 Mfd	C42	.001 Mfd
R16	33K	R83	47 ohms	C17	50 Mfd	C43	.1 Mfd
R17	100K			C18	32 Mfd	C44	32 Mfd
R18	27K			C19	12.5 Mfd	C46	12.5 Mfd
R19	15K			C20	12.5 Mfd	C47	50 Mfd
R20	6.8K			C21	50 Mfd	C48	64 Mfd
R21	10K			C22	12.5 Mfd	C49	2000 Mfd
R22	1.5K			C23	.068 Mfd	C50	3000 Mfd
R23	47K			C24	.1 Mfd	C51	400 Mfd
R24	10K			C25	.47 Mfd	C52	.01 Mfd
R25	100K H.S.			C26	12.5 Mfd	C53	200 pf
R26	33K H.S.					VT13	OC81Z
R27	10K	VT1	2N2613			VT14	OC71
R28	2K Pre-set	VT2	OC71			VT15	AC128
R29	25K Pot	VT3	OC71			VT16	AD162
R30	47K	VT4	OC71			VT17	AD161
R31	100K	VT5	2N2613				
R32	100K	VT6	OC44				

Metal Rectifier(s) — H129PE01B. Fuse — 250 mAmp. surge-resisting

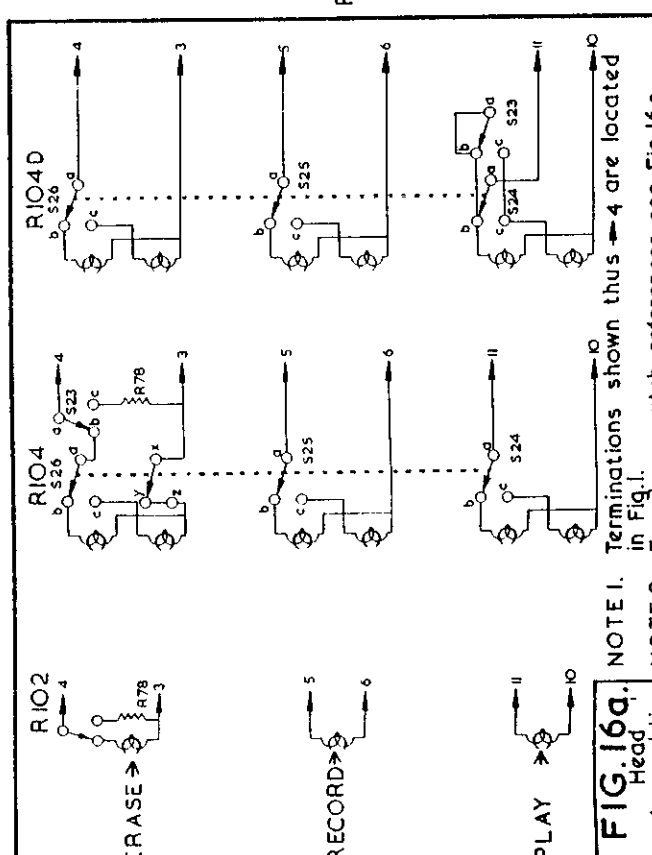
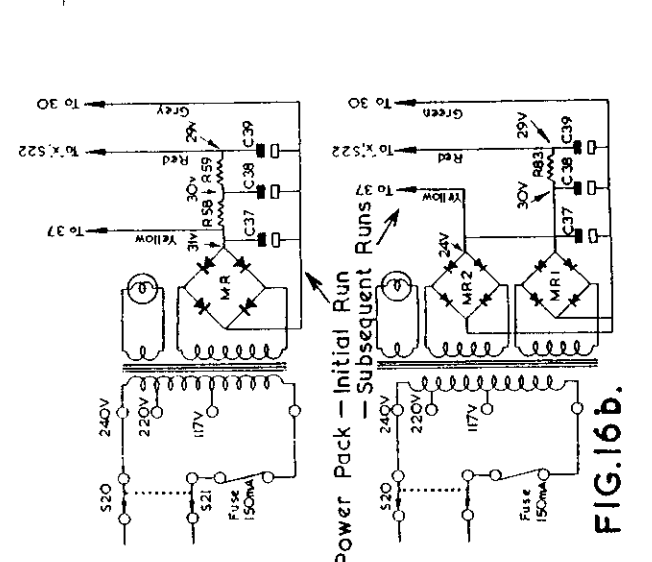
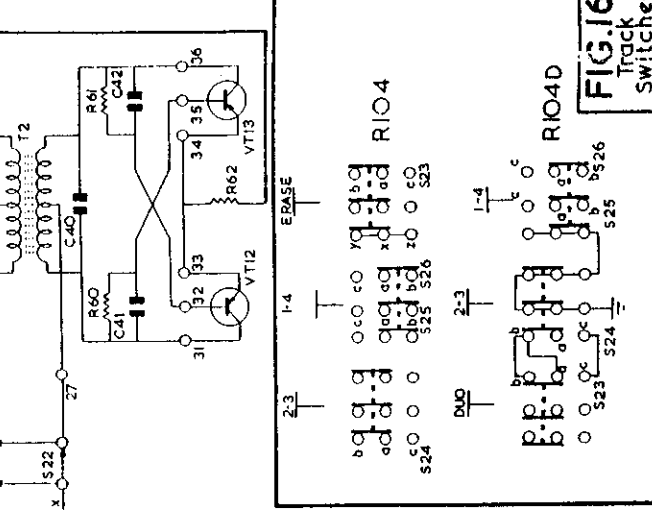
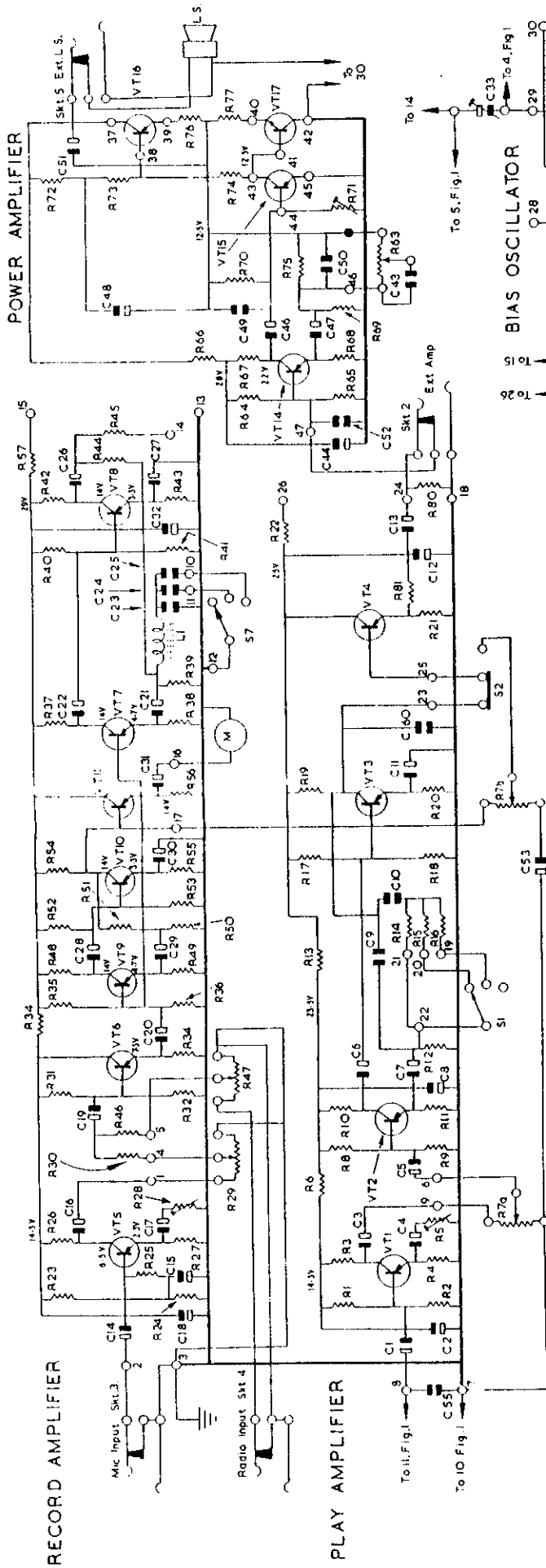

FIG. 16a. Head Assemblies

NOTE 1. Terminations shown thus \rightarrow 4 are located in Fig. 1.

NOTE 2. For above switch references see Fig. 16c.

FIG. 16c. Track Switches

LEGEND FOR FIGURE 17

R1	200K H.S.	R24	15K	C1	12.5 Mfd	C22	12.5 Mfd	VT1	2N2613
R2	47K H.S.	R25	100K	C2	32 Mfd	C23	.068 Mfd	VT2	OC71
R3	33K H.S.	R26	22K	C3	12.5 Mfd	C24	.1 Mfd	VT3	OC71
R4	10K H.S.	R27	15K	C4	50 Mfd	C25	.47 Mfd	VT4	OC71
R5	2K Pre-set	R28	4.7K	C5	12.5 Mfd	C26	12.5 Mfd	VT5	2N2613
R6	22K	R29	270 ohms	C6	12.5 Mfd	C27	50 Mfd	VT6	OC44
R7A	25K } Ganged	R30	47K	C7	50 Mfd	C28	12.5 Mfd	VT7	OC71
R7B	25K }	R31	6.8K	C8	64 Mfd	C29	50 Mfd	VT8	OC71
R8	150K	R32	4.7K	C9	470 pf	C30	50 Mfd	VT9	OC71
R9	39K	R33	1K	C10	.01 Mfd	C31	12.5 Mfd	VT10	OC71
R10	22K	R34	47K	C11	50 Mfd	C32	32 Mfd	VT11	OC71
R11	10K	R35	15K	C12	32 Mfd	C33	10-60 pf	VT12	OC31Z
R12	230 ohm	R36	220K	C13	12.5 Mfd	C34	300 pf	VT13	OC31Z
R13	39K	R37	250K Pot	C14	12.5 Mfd	C35	300 pf		
R14	27K	R38	15K	C15	50 Mfd	C36	10-60 pf		
R15	10K	R39	4.7K	C16	12.5 Mfd	C37	1000 Mfd		
R16	33K	R40	220 ohms	C17	50 Mfd	C38	1000 Mfd		
R17	100K	R41	100K	C18	32 Mfd	C39	1000 Mfd		
R18	27K	R42	47K	C19	12.5 Mfd	C40	.01 Mfd		
R19	15K	R43	6.8K	C20	12.5 Mfd	C41	.001 Mfd		
R20	6.8K	R44	4.7K	C21	50 Mfd	C42	.001 Mfd		
R21	10K	R45	1K			C43	200 pf		
R22	1.5K	R46	10K						
R23	47K	R47	100 ohms						
R24	10K	R48	22 ohms						
R25	100K H.S.	R49	22 ohms						
R26	33K	R50	47K						
R27	10K	R51	330 ohms						
R28	2K Pre-set	R52	22K						
R29	25K Pot	R53	47K						
R30	47K	R54	1K						
R31	100K	R55	1K						
R32	100K	R56	10K						
R33	22K	R57	100 ohms						
		R58	22 ohms						
		R59	22 ohms						
		R60	47K						
		R61	47K						
		R62	330 ohms						
		R64	22K						
		R80	47K						
		R81	1K						

Rectifier—H129PE01B

Fuse—250 mAmp. surge-resisting

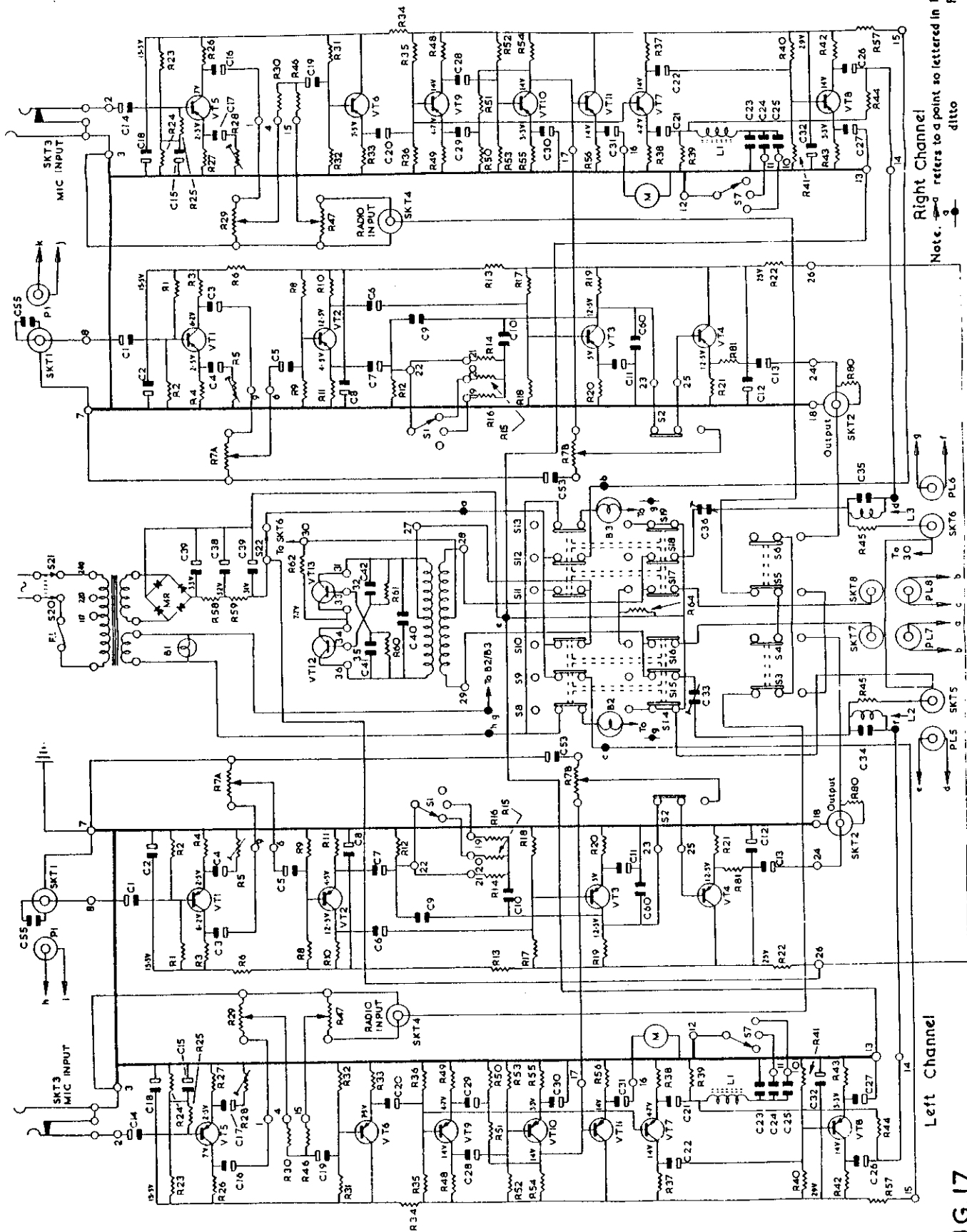

Right Channel
 Note: \rightarrow refers to a point so lettered in Fig. 2
 \rightarrow ditto

FIG. 17.

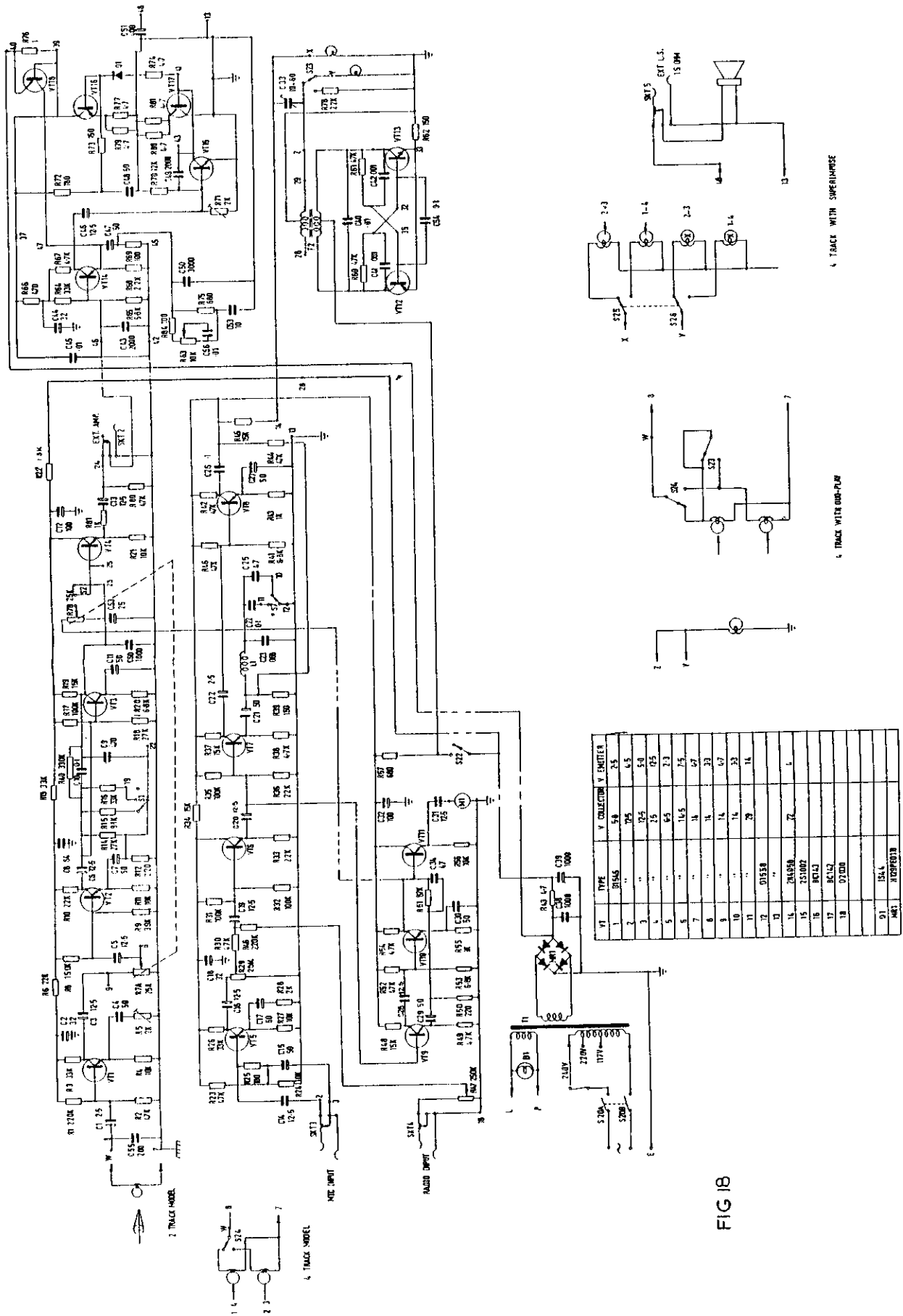
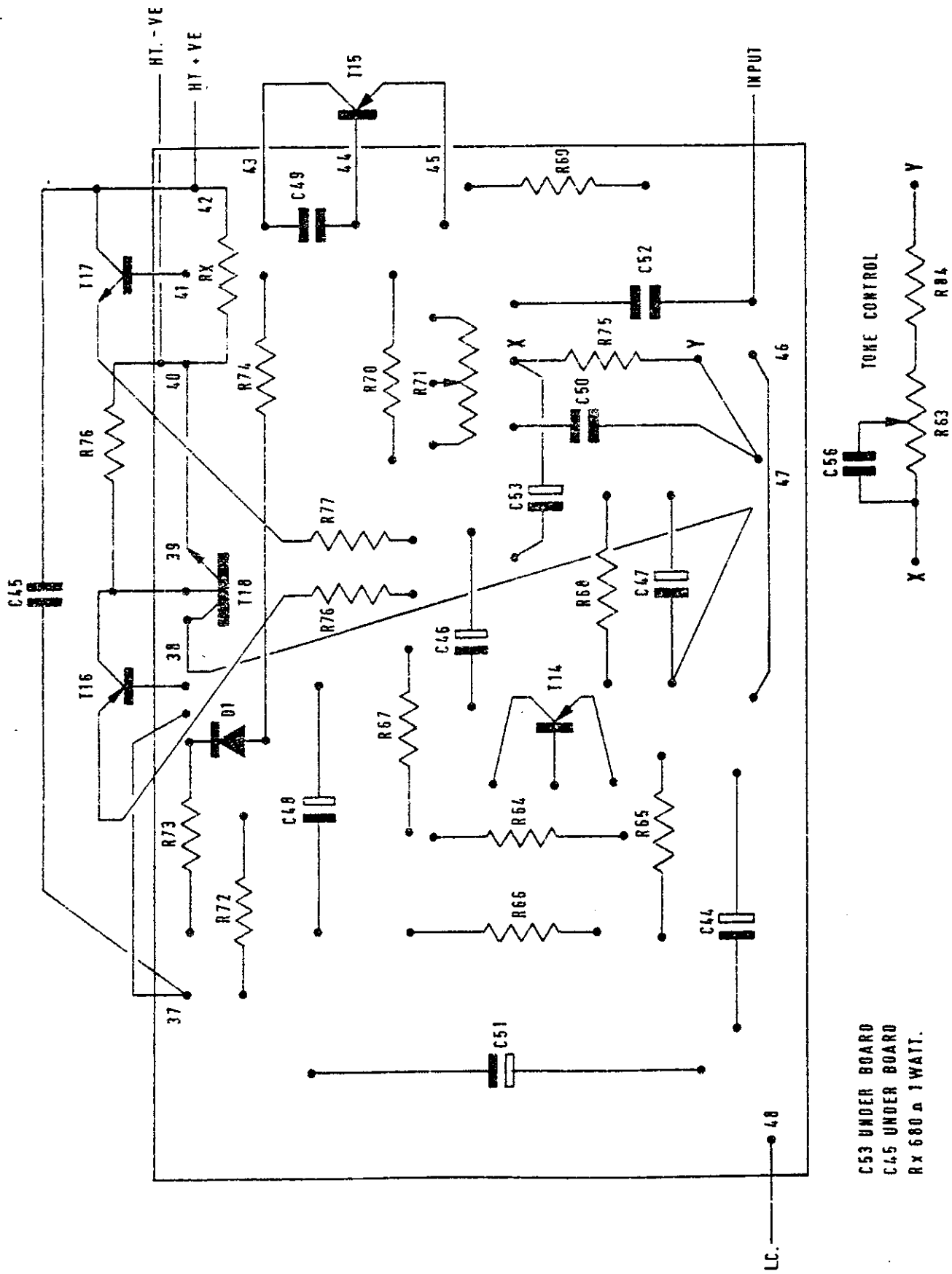

FIG 1B



C53 UNDER BOARD
 C45 UNDER BOARD
 RX 680 Ω 1WATT.

R100/200 OUTPUT P.C. BOARD