

LIFETEC

LT-7101

MODEL

SERVICE MANUAL

CONTENTS

Page

Safety Precautions	1
Technical Specifications	2
Special Features	3
Instruction Manual	4
Block Diagram	26
74LVC04A Hex Inverter	27
FAN117A 1A Adj./Fixed Linear Regulator	27
FQPF12N60 600V N-Channel MOSFET	28
HY57V641620HG 4 Banks x 1M x 16 Bit DRAM	28
LD 1086 and NCP1117 Voltage Regulators	29
TDA6111Q Video Output Amplifier	30
SDA 6000 Teletext Decoder	31
DDP 3315C Display and Deflection Processor	35
VSP 94x7B	36
TDA 7265 25+25 W /TDA 7297 15+15W Amplifier	39
TDA9885 I C Bus Controlled IF-PLL demodulators	40
Service Adjustments	43
Wave Forms	49
Part List	52

SAFETY PRECAUTIONS

GENERAL GUIDELINES

1. It is advised to insert an isolation transformer in the AC supply before servicing a hot chassis.
2. Potentials as high as 33KV are present when this receiver is in operation. Operation of the receiver without the rear cover involves the danger of a shock hazard from the receiver power supply. Servicing should not be attempted by any one who is not competent with the precautions necessary when working on the high voltage equipment. Always discharge the anode of the tube.
3. When servicing observe the original lead dress in the high voltage circuits. If a short circuit is found , replace all the parts which have been overheated or damaged by the short circuit.
4. always use the manufacturer's replacement safety components. The critical safety components marked with ∇ on the schematics diagrams should not be by other substitutes. Other substitute may create the electrical shock , fire or other hazards. Take attention to replace the spacers with the originals. Furthermore where a short circuit has occurred , replace those components that indicate evidence of overheating.
5. After servicing , see that all the protective devices such as insulation barriers, insulation papers, shields and isolation R-C combinations are correctly installed.
6. When the receiver is not being used for a long time of period of time , unplug the power cord from the AC outlet.
7. After servicing make the following leakage current checks to prevent the customer from being exposed to shock hazard.

LEAKAGE CURRENT COLD CHECK

1. Unplug the AC cord and connect a jumper between the two prongs of the plug.
2. Turn the receiver's power switch.
3. Measure the resistance value with an ohmmeter, between the jumpered AC plug and each exposed metallic cabinet part on the receiver, such as screw
- 4.

heads, aerials, connectors , control shafts etc. When the exposed metallic part a return path to the chassis the reading should be between 4Mohm and the 20Mohm. When the exposed metal does not have a return path to the chassis, the reading must be infinite.

LEAKAGE CURRENT HOT CHECK

1. Plug the AC cord directly in to the AC outlet. Do not use an isolation transformer for this check.
2. Connect a 2Kohm 10W resistor in series with an exposed metallic part on the receiver and an earth, such as a water pipe.
3. Use an AC voltmeter with high impedance to measure the potential across the resistor.
4. Check each exposed metallic part and check the voltage at the each point.
5. Reverse the AC plug at the outlet and repeat each of the above measurements.
6. The potential at the any point should not exceed 1.4 Vrms. In case a measurement is outside the limits specified , there is the possibility of a shock hazard , and the receiver should be repaired and rechecked before it is returned to the customer.

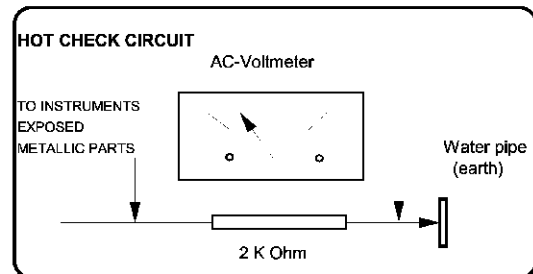

Figure 1

X-RAY RADIATION WARNING

The primary source of X-ray radiation in this receiver is the picture tube. The chassis is specially constructed to limit X-ray radiation. For continued X-ray radiation protection, replace the tube with the same type of the original one.

CAUTION

SHORT CIRCUIT THE ANODE OF THE PICTURE TUBE AND THE ANODE CAP TO THE METAL CHASSIS, CRT SHIELD, OR THE CARBON PAINTED ON THE CRT, AFTER REMOVAL OF THE ANODE CAP.

TECHNICAL SPECIFICATIONS AND THE FEATURES

Power source:	230-240V AC ,50-60Hz
Power consumption:	175 W 28" 4:3 / 28" 16:9 SF 180 W 28" 16:9 PF 180 W 29" 4:3 SF 185 W 29" 4:3 PF 185 W 32" 16:9 SF 190 W 32" 16:9 PF 200 W 33" 4:3
Stand by Power consumption :	6 W (For all sizes)
Aerial impedance :	75Ohm, Coaxial type
Receiving system *:	PAL BG PAL SECAM BG PAL SECAM BG DK/DK' PAL SECAM BG LL' PAL I
Receiving channels:	VHF BAND I , CH2-4 VHF BAND III , CH5-12 CATV CHANNLES S1-S41 UHF BAND CH21-69
Sound systems :	Mono/Stereo/NICAM (optional)
Grid 2 voltage :	0-1400V
Heater voltage :	6.3±0.2Vrms
Operating temperature :	0-45 Degrees
Safety	: IEC 65 /BS P2N
X-Ray radiation	: ACC. IEC 65/BS P2N

- : TV set is produced to receive "one" of this colour and sound systems options which is based one your countries norms and can not be changed by user except BG/DK and BG/LL' if both systems are available to receive (BG or DK and BG or LL').

NOTE : Using a subwoofer causes 20 W extra power consumption and supplies maximum 20 W extra sound output.

SPECIAL FEATURES

- 100 Hz digital scan.
- 512 page teletext (1024/2048 pages optional).
- Fasttext and/or Toptext (Optional).
- Letterbox, Subtitle 1 & 2, 16:9, 14:9 picture formats (for Widescreen TV sets).
- Digital Colour Transition Improvement (DCTI).
- Digital Comb Filter (DCF).
- Digital Luminance Transition Improvement (DLTI).
- Manual degaussing.
- Scan Velocity Modulation (SVM.) (Optional).
- TILT function (Optional).
- Dynamic Focus (Optional).
- 3 step Zoom function.
- Picture freeze function.
- Automatically switch to stand by in five minutes after a channel ceases to transmit or selecting a channel which has no transmission (Auto off function).
- PIP (2 tuner).
- PIP sound via headphone jack (except Secam LL).
- Virtual Dolby surround (Optional).
- Subwoofer (optional).
- Dynamic Bass Enhancement.
- Back audio out.
- 5 band graphic equaliser.
- Automatic Volume Limiting (AVL).
- Programme Editing Table.
- Naming the channels.
- Your TV can receive stereo channels directly (NICAM optional).
- Automatic tuning system with country selection (ATS).
- 100 Programme Memory.
- Cable/Hyperband tuner.
- Manual Fine Tuning.
- Child Lock.
- Return to the last channel viewed (SWAP).
- Normalisation system to recall the setting in memory after the volume, colour, contrast, brightness settings have been changed (PP).
- Picture adjustment using one button (Picture Smart Control).
- Sound adjustment using one button (Sound Smart Control).
- Advanced On Screen Display.
- Infrared Remote Control.
- Programmable on/off timer.
- Multi language menu system (18).
- Stereo headphone socket.
- 2 Scart Sockets: Video cassette recorder, satellite receiver, video disc player, DVD, TV games or a home computer can be connected to this AV socket with an appropriate connecting cable (3rd Scart socket is optional).
- S-Video connection.
- Audio/Video RCA sockets.

Remote control

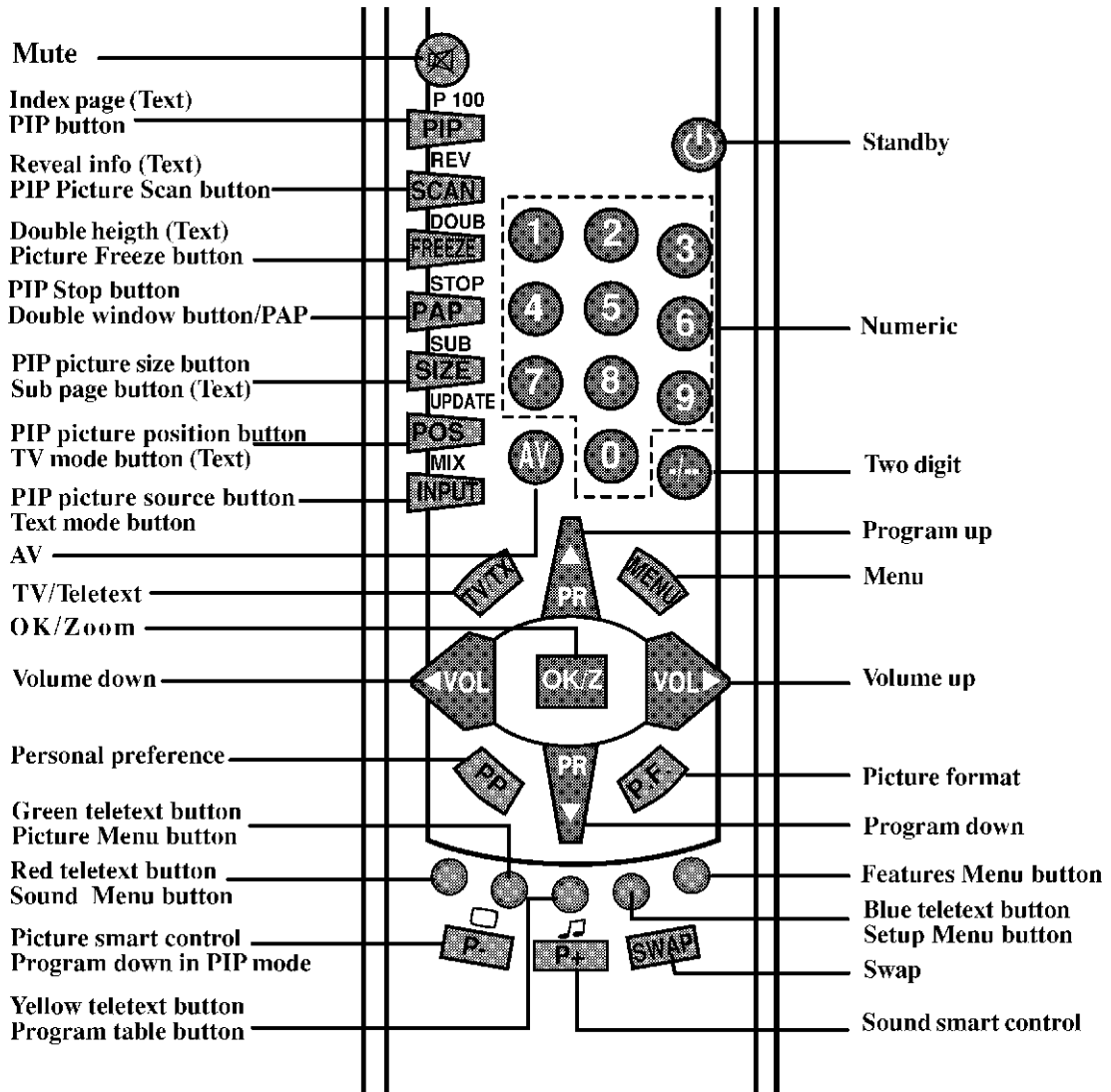

Using the TV

Turning on for the first time and Tuning

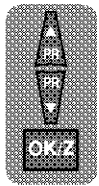

When you first turn your TV on, “Language” menu will appear. To search on the languages, use the **Program up** or **Program down**. **Volume up** or **Volume down** buttons and choose your desired language and press “OK” button.

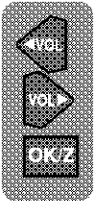

Then “Country Selection” menu will appear. Choose your country using **Program up** or **Program down**. **Volume up** or **Volume down** and press “OK” button. “Autoprogram” process will begin and all the channels will be searched and stored.

TV controls

Stand-By mode

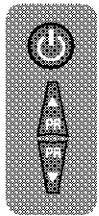

When your TV is working on, press the red “STAND-BY” button on the right upper corner of your remote control to switch off and the Stand-By indicator (Led) will be brighter. To turn on your TV again, press one off the numeric buttons, **Program up** or **Program down**.

Please Note: If you will not use your TV for a long time, do not leave it on Stand-By mode, instead switch it off from the power button on the front panel of the TV set. If you always leave your TV on Stand-By mode, demagnetization process will not occur and that will cause coloring problems. If you occurs, press the power button to switch off your TV and wait until it cools off.

Programme selection

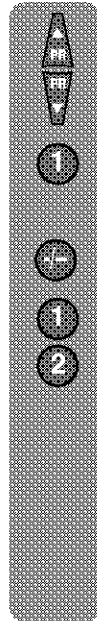

Press the **Program up** or **Program down** buttons on the TV or remote control or press a **Numeric** button to select a programme.

To select a programme whose number is greater than 9 using the numeric buttons, press the **-/--** button first and then press the two **Numeric** buttons. For example, to select programme 12, press the **-/--** button followed by **1** and then **2**.

You can also select a program by pressing in the Yellow button to see the Program Table.

PROGRAM TABLE		
P00	P005	P010
P01 ITU	P006	P011
P02 TV4	P007	P012
P03 CNN	P008	P013
P04 BBC1	P009	P014
SKIP	DELETE	
TABLE	NAME	

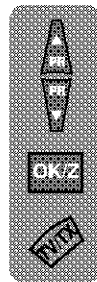

Use the **Program up** and **Program down** buttons to scroll through the programme numbers. When you find the program number you want press the **OK** button again.

Press the **TV/TX** button to close the Program Table.

Volume

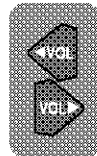

Press the **Volume +** or **Volume -** button on the TV or the **Vol ◀** or **Vol ▶** button on the remote control. A sound level bar will appear on the screen.

Mute

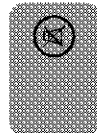

To mute the sound press the **Mute** button on the remote control. A loudspeaker symbol will appear on the screen.

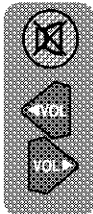

Press the **Mute** button again to restore the sound. The symbol will disappear.

Pressing **Volume up** buttons will also restore the sound. But pressing the **Volume down** button will increase the volume without restoring.

PP

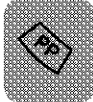

Personal preference. Press the **PP** button to revert to the default settings for the TV. (See TV setup).

Swap

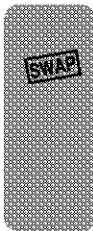

Select the programme you would like to recall by pressing **SWAP** button. Selected programme number will appear on the upper left side of the screen. While watching any programme, you can recall the selected one by pressing **SWAP** button again. If you press swap button again you can recall the last programme you watched. You can cancel SWAP function by pressing **MENU** button.

PR 01 → PR 11 → PR 12 → PR 13... → PR 01

AV

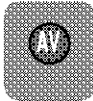

Your TV has 3 scarts so every time you press your AV button, your input will change as follows:

- 1 AV1 when using SCART socket 1 (RGB support) (Option).
- 2 AV2 when using SCART socket 2.
- 3 AV3 when using SCART socket 3 (RGB support) (Optional).
- 4 AV3-S for S-Video equipment to scart 3 (S-VHS/Scart adapter is needed).
- 5 AV4 when using the RCA sockets of the TV.
- 6 AV4-S when using the S-video socket.



Press the **AV** button again to return to TV.

Tuning the television

There are two ways of tuning your television: Manual, where you control the tuning process or

Autoprogram where the television does it all automatically.

Your TV will sort all the channels with the ATS. Sorting will be performed in the following order:

- a- Selected country's channels with teletext and channel names.
- b- Selected country's channels with teletext and without channel names.
- c- Selected country's channels without teletext.
- d- Foreign channels with teletext and channel names.

Please Note

If the TV is set to a channel with no signal the TV will return to standby in 5 minutes. The last minute remaining is displayed on the screen.

Automatic tuning (Autoprogram)

There are two ways to access the SETUP menu:

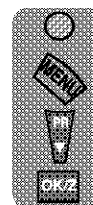

Press the blue **Setup** button.

or

Press the **Menu** button and use the **Program down** button to select **SETUP** Press the **OK** button to enter the **SETUP** menu.

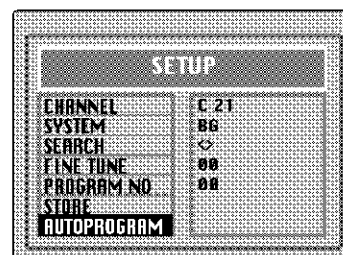
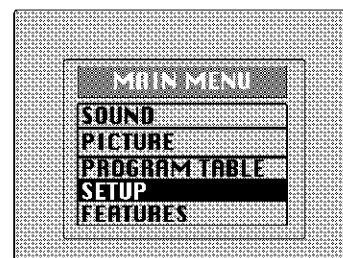

Please note

The system will displayed automatically on SYSTEM row i.e.BG, L, I, DK depending the receiving broadcasting system of the country. In some countries the broadcasting system can be both in BG/DK or BG/LL'. Only the TV sets produced with Pal Secam BG/DK or Pal Secam BG/LL' systems can receive both BG/DK or BG/LL' broadcasts. In this case the user can select the required SYSTEM using **Volume up/down** buttons.

Please note

If you do not press any buttons for 15 seconds the TV will exit the menu system.

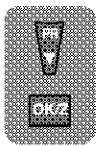

Use the Program down button to select AUTOPROGRAM and press the OK button. A list of countries will appear. Select the desired country using **Program** and **Volume** buttons.

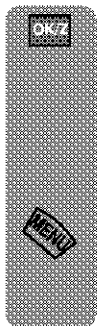

When you are sure the aerial is connected properly press the **OK** button. Autoprogram will start. AUTOPROGRAM will flash.

To cancel Autoprogram whilst it is working press the **Menu** button repetitively.

As Autoprogram stores a channel it will appear briefly on the screen before the search continues.

Your TV is now tuned and ready to use.

Please note:

If auto sort fails to arrange the programmes in the required sequence please refer to programme organising.

Manual tuning

If you want to tune manually:

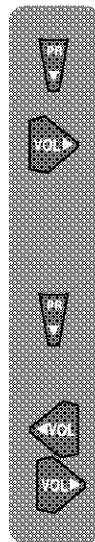

In the Setup menu select PROGRAM NO using the **Program down** button and use the **Volume up** button to change the Program No to 01.

Starting with Program 01, tune in the first channel as follows:

Use the **Program down** button to select SEARCH.

Press the **Volume up** or **Volume down** button to start the tuning search.

When the search finds a strong channel signal it will stop searching. The picture will appear.

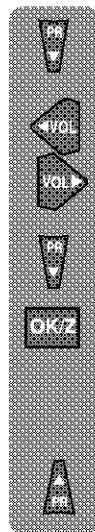
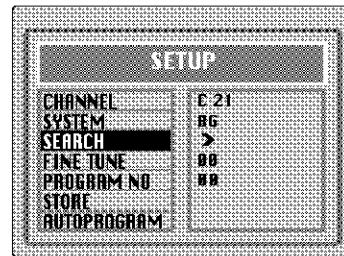

Use the **Program down** button to select PROGRAM NO.

Use the **Volume up/down** or numeric buttons to select the desired programme number.









Use the **Program down** button to select STORE. Press the **OK** button and STORED will appear on the STORE line.

You have now stored the first channel.

Use the **Program up** button to select again SEARCH and continue the tuning procedure until you have tuned in all the programmes you want or the television can receive.

Tuning with channel numbers

Enter the SETUP menu by pressing the blue button.

-  Press **OK** button when CHANNEL row is blue.
-  Use OK button to select “S” for cable channels and “C” for terrestrial broadcast.
-  Enter the channel number using the Numeric buttons or use the **Volume up/down** buttons on your remote control.
-  Use the **Program down** button to select PROGRAM NUMBER.
-  Use the **Volume up/down** or numeric buttons to select the desired programme number.
-  Use the **Program down** button to select STORE. Press the **OK** button and STORED will appear on the STORE line.
-  You have now stored the first channel.
-  Use the **Program up** button to select again CHANNEL and continue the tuning procedure until you have tuned in all the programmes you want or the television can receive.

-  To exit the SETUP menu press the TV/TX button.

Fine tuning

Although the search and Autoprogram will automatically try and tune to the best reception, in areas of poor reception a bit of fine tuning may be required.

-  In the SETUP menu use the Program up/down buttons to select FINE TUNING. Use the Volume up and Volume down buttons to fine tune.

-  When you have finished use the **Program down** button to select STORE and press the **OK** button.

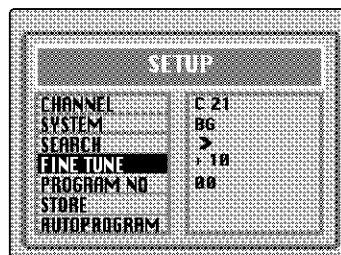

Program organising

Once you have tuned in all the channels you want, you can change their programme number, if required, and name them.



To enter the PROGRAM TABLE menu press the **Menu** button and select PROGRAM TABLE and press the **OK** button or press directly the **Yellow** button.

PROGRAM TABLE		
P01 ITU	P005	P010
P02 TU4	P006	P011
P03 CNN	P007	P012
P04 BBC1	P008	P013
	P009	P014
SKIP	DELETE	
MOVE	NAME	

PROGRAM 01 will be selected and the channel stored under PROGRAM 01 will be shown on the screen.

The details of the program will be shown across the top of the screen i.e. P1 CH31.

The buttons used to edit the programs are shown at the bottom of the display:

Blue button	-	Name
Green button	-	Move
Pink button	-	Delete
Red button	-	Skip

To name the programmes

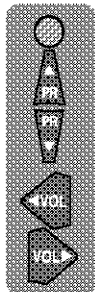

Press the **Blue** button, the selected line will turn blue and the CH will be highlighted.

Use the **Program up** and **Program down** buttons to select the letters and numbers and the **Volume up** and **Volume down** buttons to move through the name.

Press the **Blue** button again to store the name.

Repeat this process to name all the programmes.

Please Note

Some TV channels may send their names with teletext transmission. In this case their names will be automatically shown on the name line.

To move the programmes

You can move the programmes around the programme list to the order you want

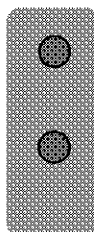

Select the programme you want to move and press the **Green** button. The programme will turn to yellow. Select the number you want to move and press the **Green** button again and the programme will be moved to that number.

All the following programmes are shifted down by one place.

To delete a programme

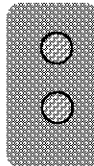

To delete a programme, select it and press the **Pink** button. The programme will be deleted.

All the following programmes are shifted up by one position.

To skip programmes

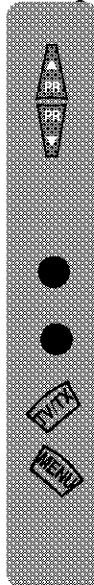

Skipped programmes will not appear when you move through the program list using the **Program up/Program down** buttons.

They can still be selected using the numeric buttons or the OK button.

Select the programs you want to skip and press the **Red** button. The program will turn red. To unskip the program press the **Red** button again.

To exit the PROGRAM EDIT press the **TV/TX** button once or the **Menu** button twice.

When you select a programme, the information you entered in the PROGRAM EDIT menu will appear on the top of the screen i.e. P1 BBC1. This will disappear after about three seconds.

TV set up

The TV set up is accessed through a menu system.

Once you have stored your set up, this is the set up the TV will default to when you switch it on.

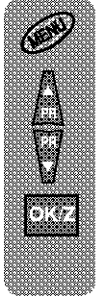

To enter the MAIN menu press the **Menu** button.

Once in the MAIN menu use the **Program up** and **Program down** buttons to select items in the menu and the **OK** to access sub menus or use the coloured fasttext buttons for quick access.

Red button - SOUND
Green button - PICTURE
Pink button - FEATURES

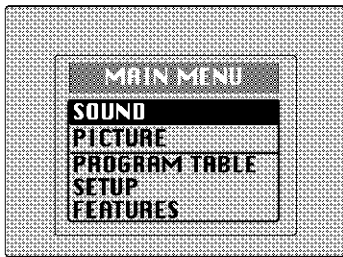

Please note

If you do not press any buttons for 15 seconds the TV will exit the menu system.

Sound menu (red button)

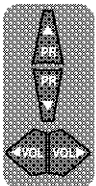
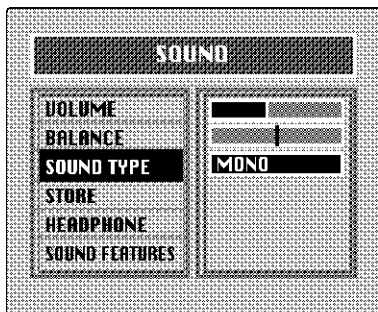

Select the required item in the menu using the **Program up/down** buttons and make the changes pressing **Volume up/down** buttons. Use the **OK** button to enter **HEADPHONE** and **SOUND FEATURES** sub menus.

Volume

Sets default volume using the **Volume up** and **down** buttons.



To save your settings, select **STORE** and press the **OK** button. **STORED** will be displayed. Press the **Menu** button to go back to the previous menu.

Balance

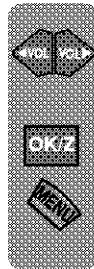

Sets the sound balance mode using the **Volume up** and **down** buttons

To save your settings, select **STORE** and press the **OK** button. **STORED** will be displayed. Press the **Menu** button to go back to the previous menu.

Sound type

This item shows **STEREO** when receiving stereo transmission and **MONO** for mono transmissions.

The TV can be produced to receive the **NICAM** broadcasts as a optional feature.

If the channel you are watching is in **Nicam stereo** the **On Screen Display** will show **NICAM STEREO** for a while.

Please Note

If, while watching a **nicam stereo** channel, the signal strength drops and the system cannot receive **nicam stereo** the **OSD** will show **MONO**. If the signal strength increases again and **nicam stereo** can be received again, the **OSD** will show **NICAM STEREO**.

Dual I/II

Some broadcasters supply the programmes in two languages. To able to listen the second language select **DUAL II** by **SOUND TYPE** using **Volume up/down** buttons.



To save your settings, select **STORE** and press the **OK** button. **STORED** will be displayed. Press the **Menu** button to go back to the previous menu.

Headphone

You can set up the volume, balance, bass treble and sound type (stereo or mono) of the headphone output. Use **OK** button to enter the **HEADPHONE** menu.

You can also listen to the **PIP** window by choosing **PIP** from the **SOURCE** line. (Except Secam L TV sets).

Use **Program down** button to go to **SOURCE** and press **Volume Up** or **down** button to select **PIP**.



Please Note

1. PIP listening through the headphone jack is not available in Secam LL TV sets.
2. If the mainscreen is AV input source, you can not listen to any other input sources from the headphone jack. In such cases headphone source can not be chosen as PIP.



To save your settings, select **STORE** and press the **OK** button. **STORED** will be displayed. Press the **Menu** button to go back to the previous menu.

Sound Features

You can set up the Sound Mode, AVL Mode Dynamic Bass, Subwoofer (Optional) and Equalizer from **Sound Features** menu.

To access the **Sound Features** menu press the **Red** button on the remote control and press **Volume down** button to select **Sound Features**.

Press **OK** to enter the **Sound Features**.

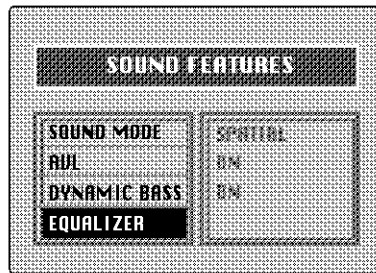

Sound mode

You can select **NORMAL**, **SPATIAL** or **DOLBY VIRTUAL** (optional) using the **Volume up/down** buttons.

SPATIAL sound is an 'expanded stereo'. It gives the impression that the two speakers in the TV are further apart than they really are.

DOLBY VIRTUAL is based on Dolby Pro Logic decoding for production of the Left, Right, Centre and Virtual Surround Sound channels using two loudspeaker.

® "DOLBY", "VIRTUAL DOLBY SURROUND" and  the double-D symbols are trademarks of Dolby Laboratories Licensing Corporation.

Please Note

To get the surround effects in Virtual Dolby mode, you must apply a Dolby Pro Logic coded input to the TV. You can't adjust the **AVL** and **EQUALIZER** in **DOLBY VIRTUAL** mode.

AVL

TV transmitters have different sound levels. **AVL** (automatic volume limiting) maintains the same sound level as you switch from program to program.

To apply this press **Volume up** or **down** button and select **ON** for **AVL** in **Sound Features** menu.

Dynamic Bass

To give depth effect to bass sound you can select **Dynamic Bass** as **ON**.

To supply this press **Volume up** or **down** button and select **ON** for **Dynamic Bass** in **Sound Features** menu.

Note: If you select **Dynamic Bass** as **ON** Subwoofer will also be automatically **ON**. (If the set has subwoofer option).

Equalizer



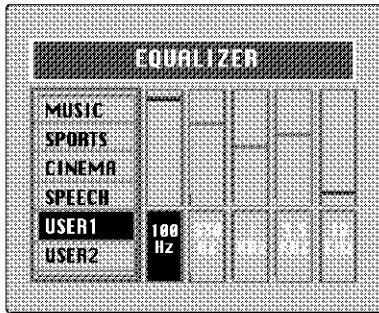



To access the 5 band equalizer menu press **Volume up** or **down** button and press **OK** on the **Equalizer** line.



In this menu there are a series of preset equalizer settings for different types of sound output.

There are four music settings - MUSIC, SPORTS, CINEMA, SPEECH and USER1 & USER2 modes.

USER modes allow you to set your own sound outputs as follows:

-  Press the OK button to enter the EQUALIZER menu.
-  Use the **Program down** button to select USER1.
-  Press OK button to adjust the frequency band levels.
-  Use the **Volume up** button to select the KHz column you want to change.
-  Use the **Program up/down** buttons to make the changes.
-  To save your settings, press the **OK** button. Press the **Menu** button to go back to the previous menu.

You can also adjust the settings of USER2 by the same method.

You can change the equalizer setting whilst watching the TV using the sound Smart control.

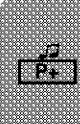
-  Press the sound **Smart control** to page through the different equalizer settings and select the one you want.

Once you have switched the TV off the equalizer setting will revert to the stored setting.

-  When you have finished in the Sound sub-menu select STORE and press the **OK** button.

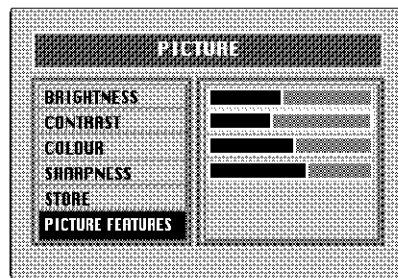

-  To exit the sub-menu press the **Menu** button and return to the main menu.

Picture menu (Green button)

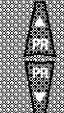

The picture menu allows you to set up the following:

BRIGHTNESS
CONTRAST
COLOUR
SHARPNESS
and the other PICTURE FEATURES

-  To change, for example, the colour, select it using **Program up and down** buttons.
-  Use the **Volume up** and **Volume down** buttons to change the setting.
-  To save your settings, select STORE and press the **OK** button. STORED will be displayed.
-  These settings are stored as USER picture type.

You can change the picture type whilst watching the TV using the picture Smart control.

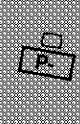
-  Press the picture **Smart control** to page through the different picture types and select the one you want: SOFT, NATURAL, RICH or USER.

Picture Features

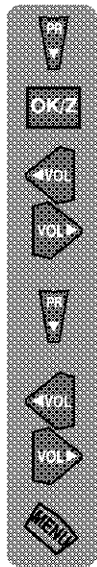

In the picture menu use the **Program down** button to select **PICTURE FEATURES** and press OK.

In this menu you can adjust the picture quality features.

Use the **Program up** and **down** buttons to select your desired picture feature and use **Volume up** and **down** buttons to adjust this feature.

NOISE REDUCTION: You can reduce the noise effects in the pictures by selecting low, medium or high.

CTI (Colour Transient Improvement): You can improve the colour transitions in the picture by selecting ON or OFF.

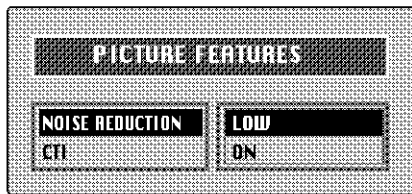

IMPORTANT NOTE: Your TV has Digital Comb Filter and DLTI (Digital Luminance Transient Improvement) features to improve picture quality. These features are set ON and they can not be changed by the end user.

Features Menu (Purple button)

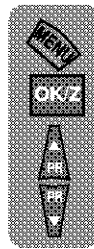

To select **Features** menu press the menu button and using the **Program up** and **down** buttons select **Features**.

You can also select the **Features** menu directly by pressing the **purple** button on the remote control.

The **Features** menu allows you to set up the following:

PIP PROGRAM
CHILD LOCK
BACK GROUND
BLUE BACK
DEGAUSS
AV OUT
LANGUAGE
TIMER

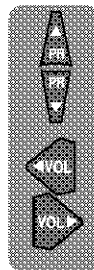

Use the **Program up** and **down** buttons to select the feature you wish to change and use **Volume up** and **down** buttons to adjust this feature.

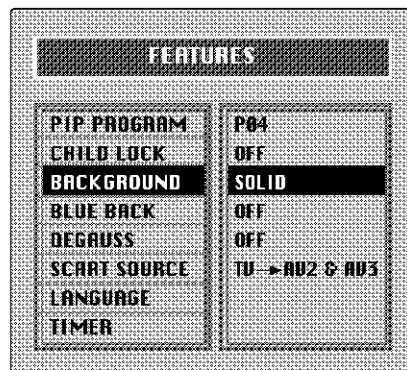

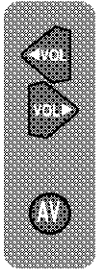

PIP Program: You can select the program to be displayed on the PIP sub-picture by pressing **Volume up** and **down** buttons or you can also press the numeric buttons to select the PIP program directly. To select AV input press the **AV** button repeatedly.

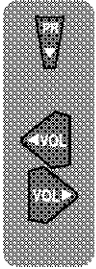

Child Lock: Using the **Child Lock**, you can lock any Program you want so that adult channels can not be watched by children.

You can cancel child lock any time you want. To cancel **Child Lock**, select **Child Lock** as OFF when you are watching that program.

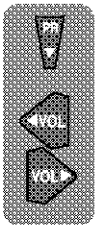

Background: You can adjust the menu background as **SOLID**, **MESHED**, **CONTRAST REDUCTION** and **NONE**.

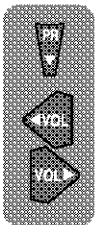

Blue Back: When there is no broadcast, you can select the background purely blue instead of snowy picture.

Select **blue back** as ON.

Degauss: If you leave your TV on stand-by mode for a long time or because of strong electro-magnetic field sources, there may be cloudy effects over the picture.

To prevent such effects select **DEGAUSS** and press **Volume up** button.

DEGAUSS will be ON for a short time, the screen will be cleaned and **DEGAUSS** will be OFF again.

Scart Source: You can select the output from your TV to the devices connected to your 2nd and 3rd scarts. So if you want to record or copy the program you are watching, you should output this program to AV2 or AV3, inputs.

The following options are possible

- TV→AV2 & AV3: The current program you are watching,
- TUNER1→AV2 & AV3: The program you have last selected,
- TUNER2→AV2 & AV3: The program you have last selected for PIP sub-picture,
- AV1, AV2, AV3, AV3-S, AV4, AV4-S→AV2 & AV3: The devices connected to these inputs; are output to the 2nd and 3rd scarts.

Note: TUNER2 option, is not available in Sec LL' TV sets.

Note: 3rd. Scart is optional.

Language: You can select one of the 18 languages by pressing OK button in the language selection.

Timer: Use **Program up** and **down** buttons to select **Timer** in the features menu. Using the Timer function, you can switch to a specific programme at a pre-programmed time or you can turn your TV off at the time you want your TV to be turned off.

Press OK to access the **Timer** menu.

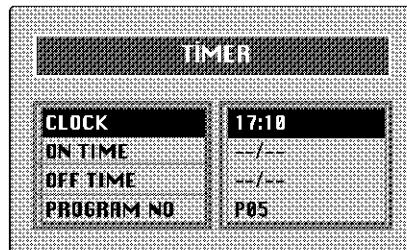

Clock: Use the numeric buttons to set the real time.

On Time: Use the numeric buttons to set the time that you want your TV to be turned on (TV should be on stand-by mode).

Off Time: Use the numeric buttons to set the time that you want your TV to be turned off (Stand-by mode).

Program No: Use the numeric buttons to set the programme number that will be shown when you set the **On Time**.

Picture format

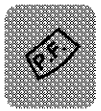

You can adjust the picture format of your TV according to the program format you are watching. Press the "P.F." button to change the Picture format.

Available formats are 16:9, 14:9, 4:3, Letterbox, Subtitle1, Subtitle2.

16:9 and **14:9** are the screen formats of widescreen TV sets (28" SF/PF, 32" SF/PF). The TV will automatically switch to this format if it detects 16:9 format from the SCART inputs.

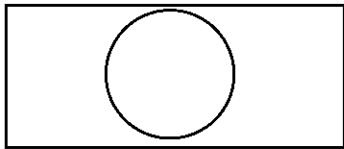

4:3, conventional TV picture format.

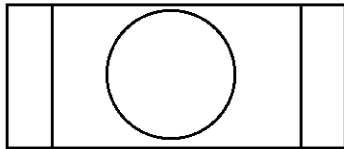

L Box (Letter box), Useful for watching video, some film formats and Pal-Plus format.

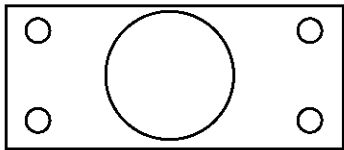

Subtitle1: If you can not see subtitles at the bottom of the screen, especially when watching 4:3 pictures in Letter box format, select Subtitle1.

Subtitle2: When Subtitle1 is not enough, select the picture format as Subtitle2.

Subwoofer (optional)

A sub woofer speaker can be fitted within the TV case as an option depending to the model.

For 33"(84cm) TV sets there is an external subwoofer (optional) to be fixed as shown below.

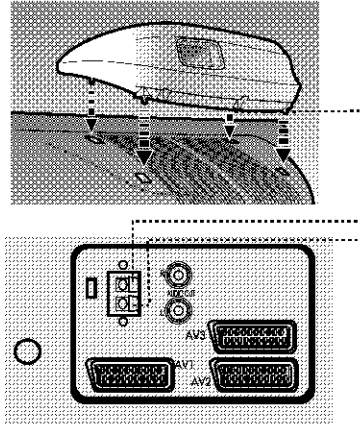

Select Sound menu and press **Program down** button to access Sound Features menu.

Press **Program down** button and select SUBWOOFER line.



Press the **Volume up** button to switch the Subwoofer on or off.

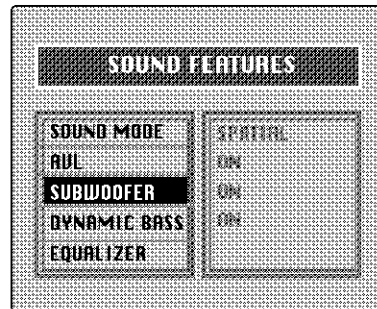

Note: If your TV has Subwoofer and if you turn on the Dynamic Bass, the subwoofer will also automatically turn on. You can not turn your subwoofer off when Dynamic Bass is on.

Setup menu (blue button)

Program table menu (yellow button)

These two menus are explained under "Tuning the TV" and "Program Organising".

OTHER FEATURES



Picture freeze

When you press "FREEZE" key on your remote control, the picture on the screen becomes fixed. To get out of the position, press the same key again.



Picture scan

You can scan the programmes starting from the current programme you have been watching, on the screen within twelve frames. Press "SCAN" key on your command for this.

To view the desired one from these programmes, press "OK" during scanning. The programme you chose will appear on the screen. To exit, press "SCAN" key. Blank programmes will not be scanned.



Zoom Function

Pressing OK/Z button zooms in to the picture. Zoom function is performed towards the center of the picture.

There are 3 steps Zoom, each time you press the OK/Z button. ZOOM1, ZOOM2, ZOOM3. You can also scroll on the picture by pressing **Program up** or **down** and **Volume up** and **down** buttons.

PIP OPERATION (OPTIONAL)

2 Tuner PIP function allows you to watch 2 programmes or other inputs like DVD, VCR or satellite receiver at the same time through its PIP window. It includes lots of functions like, SWAP, SIZE, POSITION, ZAPP and DOUBLE WINDOW.



On and off

Press the **PIP** button to switch on the PIP picture. Press again to switch it off.

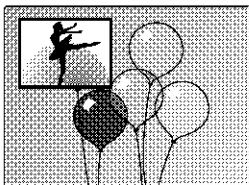

Input mode selection for PIP picture

Press the **INPUT** button to select the AV input signal for the PIP picture.

Each time this button is pressed, each input signal for the PIP picture is displayed as shown below.

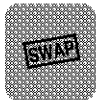
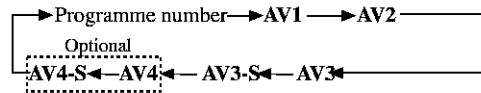

Swapping between main and PIP pictures

Press the **SWAP** button to exchange the main and PIP pictures.

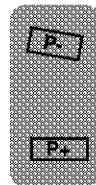
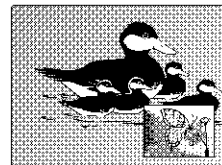
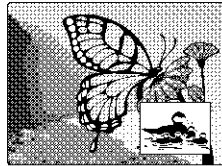

ZAPP: Programme selection for PIP picture

Press the **P-/P+** buttons The selected sub-programme number is displayed just below the sub picture.

PiP User Hints

- 1- It is not possible to watch AV2, AV2S at the same time on main screen and PIP screen. PIP picture will automatically switch to AV3 mode and it is also valid for AV3 and AV3S.
- 2- In NTSC mode from scart, only one SCAN MODE is available and double window (PAP) can not be displayed.
- 3- During tuning scan, all programs that are found after Auto-Programming will be displayed.
- 4- PIP picture in AV2S and AV3S inputs are only black and white.



PIP picture size

Repeatedly press the **SIZE** button to select the desired PIP picture size. The sub picture appears as 1/9 size of the main picture, followed by 1/16.

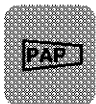
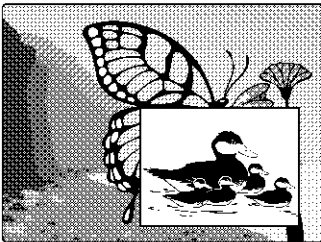
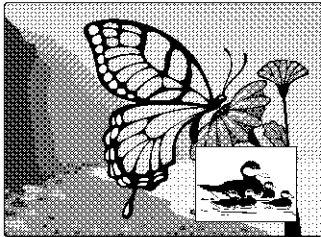

DOUBLE WINDOW

If you press the **PAP** button then the double window function will be displayed by putting the PIP window on the half of the main picture.

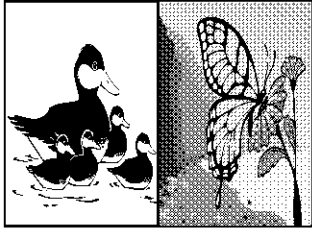

PAT (Picture and Text)

In the double window function, you can also display the teletext screen in the second window. Press the **PAP** button to see the double window function and then press the purple button on the remote control to see the PAT mode.



PPT (Picture Picture Text)

In the double window function, you can also display two pictures and one teletext page at the same time.

1. Press the **PAP** button to see the double window function.
2. Press the **TV/TX** button on the remote control.
3. Press the purple button on the remote control to see the PAT mode.

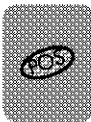
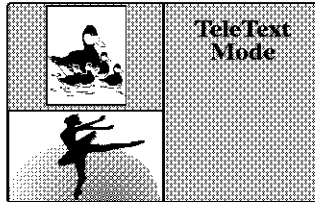

PIP picture position change

Press the **POS** button repeatedly until desired position is achieved. The PIP picture moves clockwise.

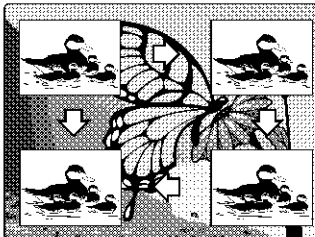

Programme scan

This function enables you to search all the stored stations in 12 PIP pictures.

To select desired one press **OK** button. To exit press **SCAN** key.

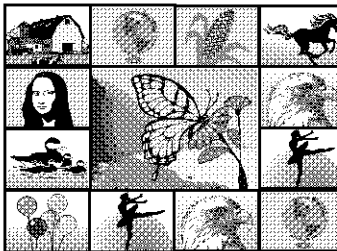

Using Teletext

Teletext is an information system that displays text on your TV screen. Using the teletext control buttons you can view pages of information that are listed in the teletext index.

Please Note

No on screen display is available in text mode. The contrast, brightness and colour cannot be changed but the volume control is still available.

To enter Text mode

Please Note

Make sure the TV channel you are watching transmits teletext.

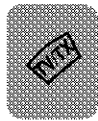

Press the **TV/TEXT** button. The text page will appear, normally the index page.

To exit Text mode

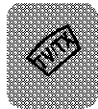

Press the **TV/TXT** button. The TV will return to the channel you were watching.

To select a page of text

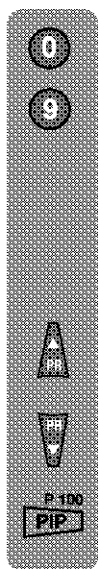

Find the number of the page in the index and enter it using the **Numeric** buttons. The number of the page will appear in the top left hand corner of the screen.

The page counter will search for your page. When it finds it, the page will be displayed.



To move to the next page of text press the **Program up** button.



To move to the previous page press the **Program down** button.



To return to the index page press the **P100** button.

TV/text mix

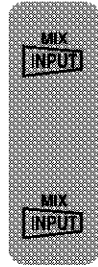

To view a page of text whilst watching a TV programme press the **MIX** button. The text will be superimposed over the TV programme.

Press the **MIX** button again to return to the text page.

Page search whilst watching TV

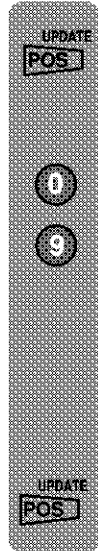

In Text mode press the **Update** button. The TV will return to TV mode with the text page number in the top left hand corner of the screen.

Enter the page number you want using the **Numeric** buttons.

The top line of the text page will appear whilst the text searches for your page. When the page is found the number will remain in the top left hand corner of the screen.

Press the **Update** button to view your selected page of text.

Double height text

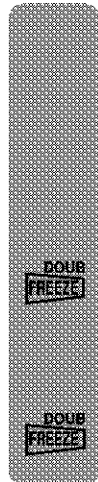

If you have difficulty reading the text on the TV you can double the height of the text.

Press the **Double height** button. The top half of the page will be displayed in double height text.

Press the **Double height** button again. The bottom half of the page will be displayed in double height text.

Press the **Double height** button again to return to the full page.

Page Stop

If the page of text you have selected contains sub pages, these sub pages will automatically be displayed in order with a delay to allow you to read the page.



To stop the move to the next sub page press the **STOP** button. **STOP** will appear in the top left hand corner.



To continue moving through the sub pages press the **STOP** button again.

To select a sub page

If the page of text you are viewing contains sub pages, the number of the sub page you are on and the total number of sub pages is displayed on the right of the screen i.e. 1/7.



To select a sub page press the **SUB** button. The number in the top left hand corner will be replaced by **S** followed by 4 asterisks.



Enter the number of the sub page, using the **Numeric** buttons in the format S0001 for sub page 1.

The teletext will search for the sub page. This may take some time. To return to the TV whilst the teletext is searching press the **Update** button.

When the page number is found it will appear in the top left hand corner of the screen.



Press the **Update** button again to view the text page.

To reveal information



Press the **Rev** button to reveal concealed information (quiz answers etc.).



Press the **Rev** button again to conceal the information again.

Clock

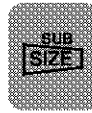

Press the **Sub** button, whilst watching a TV program, to display the time.

Fast text

At the bottom of the teletext screen is a row of subject headings in red, green yellow and blue.

The remote control has a row of coloured buttons corresponding to the row of coloured subjects on the screen.

Pressing one of the coloured buttons will take you directly to the page corresponding to the subject heading.

Toptext (optional)

At the bottom of the teletext screen is a row of subject headings in yellow and blue. Pressing yellow or blue buttons on the remote control, selects the related Subject. Next page can be selected by pressing the red button and previous page can be selected by pressing the green button.

Note: Fasttext and Toptext features are not available in every program.

Connecting external equipment

You can connect a wide range of audio and video equipment to your TV.

Connecting a video recorder

① Via SCART

Make sure the TV and video recorder are both switched off.

Plug one end of the SCART lead (not supplied) into the back of the video recorder and the other end into one of the SCART sockets on the back of the TV.

Switch on the video recorder and the TV.

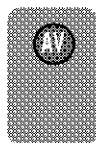

Press the **AV** button on the remote control to select AV1, AV2 or AV3 (optional) to correspond with SCART socket you are using on the back of the TV.

Please note:

You can connect a RGB external equipment via Scart 3 (optional) or Scart 1. It is necessary to you use full Scart cable for this purpose.

Select the video outputs of external device by using its menu to RGB if it's available.

② Via RCA lead (optional)

Make sure the TV and video recorder are both switched off.

Plug one end of the RCA lead into the video and audio out sockets on the back of the video recorder and plug the other end into the video and audio in sockets of the TV.

If the sound is in mono use the Audio Input L. In the SOUND menu select MONO.



Press the **AV** button repetitively and select the AV3 (AV4 optional) mode.

Please note:

When using RCA lead, you should select AV4 in 3 Scart models and AV3 in 2 Scart models.

1 Via aerial socket

Make sure the TV and video recorder are both switched off.

Unplug the aerial lead from the TV and plug it into the aerial socket on the video recorder (if fitted).

Plug a coaxial plug into the RF out socket on the rear of the video recorder and plug the other end into the aerial socket of the TV.

Switch on the video recorder and the TV.

If your video recorder has a test signal, switch it on. (Refer to the video recorder user guide).

See 'Tuning the TV' and carry out the tuning procedure for the video recorder test signal. Select a programme number 0.

2 S-Video Player

If you have an S-Video player you can connect it to SCART socket 3 (optional) via an adaptor from scart to S-Video/RCA audio (not supplied).



Press the AV button repetitively to select AV3-S.(3 scart models only)

3 Via RCA lead and S-Video socket

You can also connect it through the S-Video socket of the TV.

Plug the S-Video plug into the S-Video socket and the audio leads into the audio sockets.



Press the AV button repetitively to select AV3-S or AV4-S (optional).

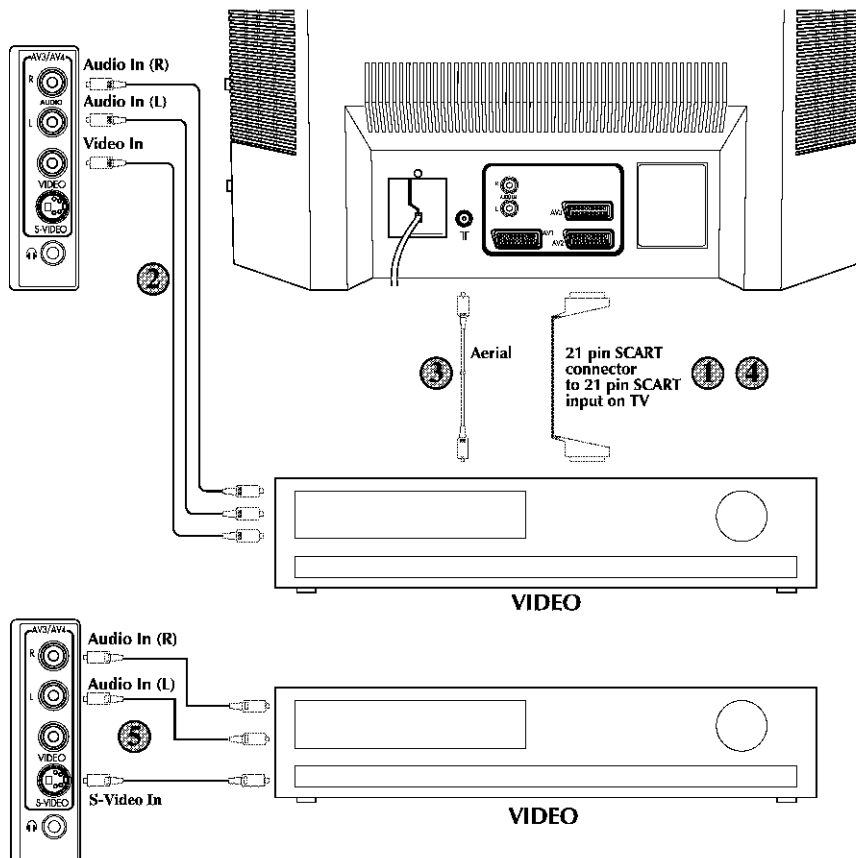

Connecting a DVD player

1 Via SCART

Make sure the TV and DVD player are both switched off.

Plug one end of the SCART lead (not supplied) into the back of the DVD player and the other end into one of the SCART sockets on the back of the TV.

Switch on the DVD and the TV.

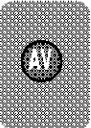
 Press the AV button on the remote control to select AV1, AV2 or AV3 correspond with SCART socket you are using on the back of the TV.

Note: Scart 1 and Scart 3 (optional) will give you RGB picture quality. For DVD connections RGB capable scart sockets (AV1 or AV3) are recommended.

2 Via RCA lead (optional)

Make sure the TV and DVD player are both switched off.

Plug one end of the RCA lead into the video and audio out sockets on the back of the DVD player and plug the other end into the video and audio in sockets of the TV.

 Press the AV button repetitively and select the AV3 (AV4 optional) mode.

3 Via RCA lead and S-Video socket

You can also connect it through the S-Video socket of the TV.

Plug the S-Video plug into the S-Video socket and the audio leads into the audio sockets.

 Press the AV button repetitively to select AV3-S or AV4-S (optional).

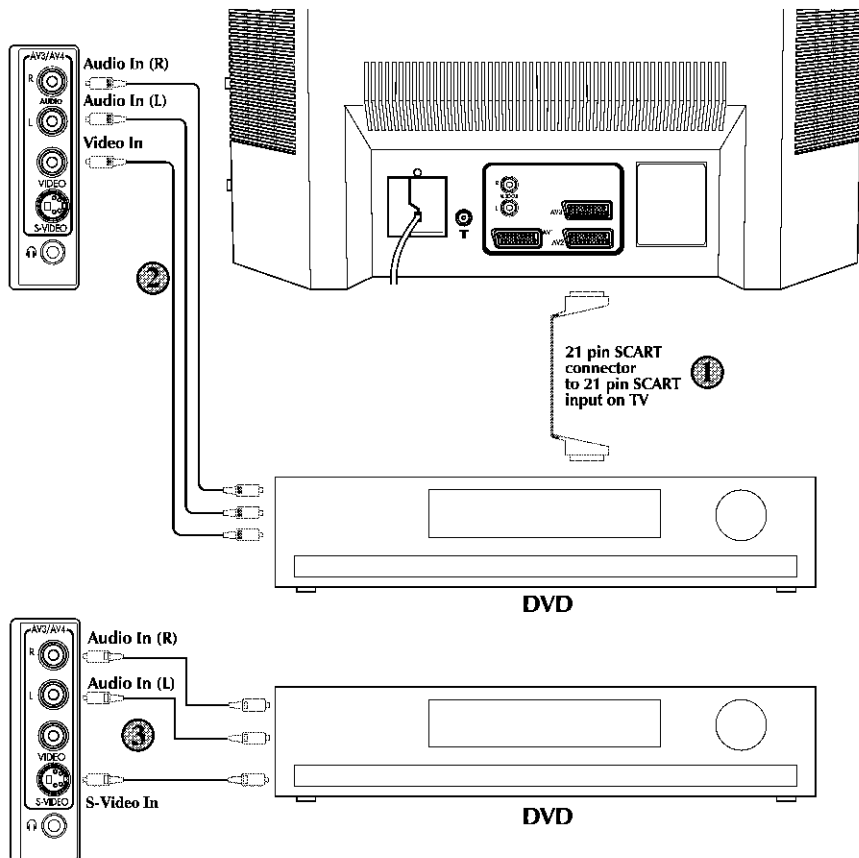

Connecting a decoder

Via SCART

Make sure the TV and decoder are both switched off.

Plug one end of the SCART lead (not supplied) into the back of the decoder and the other end into the SCART 1 on the back of the TV.

Switch on the decoder and the TV.

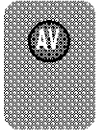

Press the **AV** button on the remote control to select AV1.

② Via RCA lead

Make sure the TV and decoder are both switched off.

Note: For Decoder connection Via RCA lead your Decoder device should have the tuner built in.

Plug one end of the RCA lead into the video and audio out sockets on the back of the decoder and plug the other end into the video and audio in sockets on the TV.



Press the **AV** button repetitively and select the AV3 mode (AV4 optional).

Please Note

You can record from one external device to another via scart sockets. You should select the source and destination of video using FEATURES menu. If you select the source as AV3/AV3-S or AV4/AV4-S (optional) you will have a "WARNING: COPY FUNCTION ACTIVE" message on the screen. You will not have picture at AV4/AV4-S if you select source AV3/AV3-S or vice versa.

You can connect NTSC supported equipment to the TV via the SCART sockets and adjusting the colour via the PICTURE menu.

Select TINT by using **Program down** button and use to adjust the colour. **Volume up** and **down** buttons.

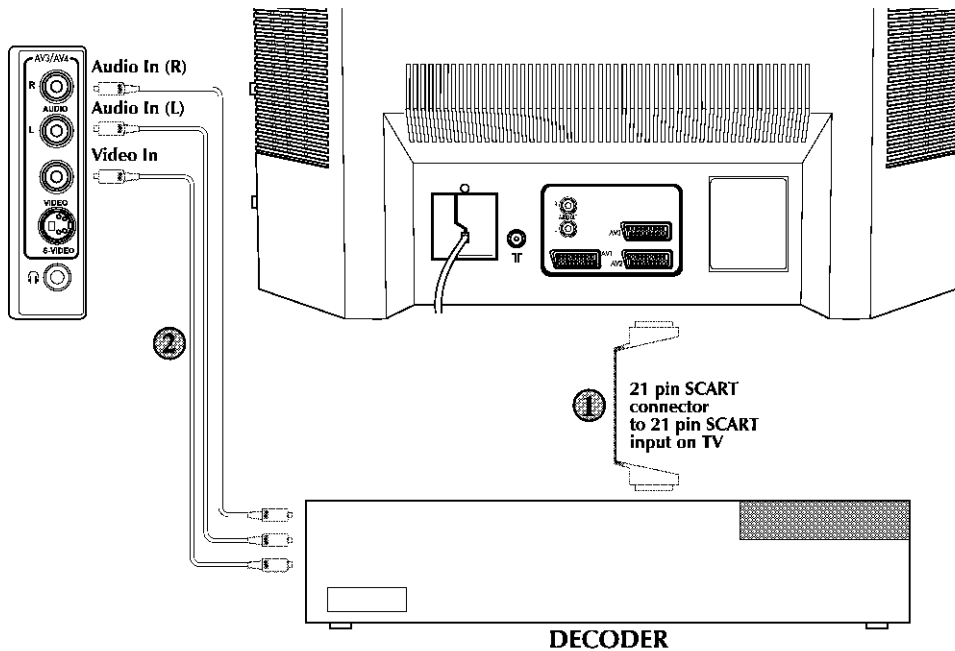

Connecting TV with video and satellite/digital receiver

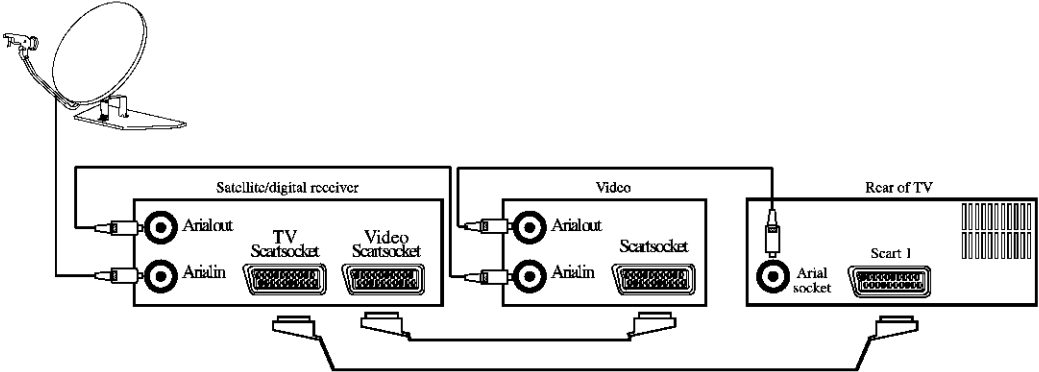

Connecting TV with camcorder

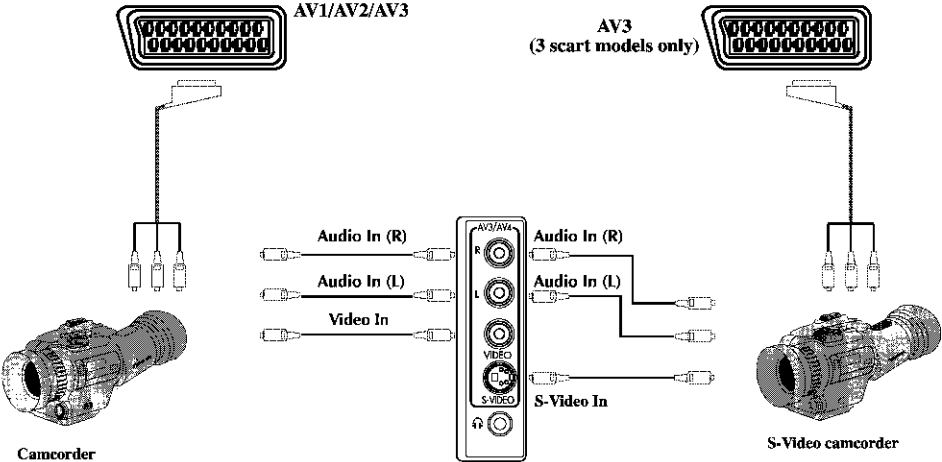

Connecting TV games and computer

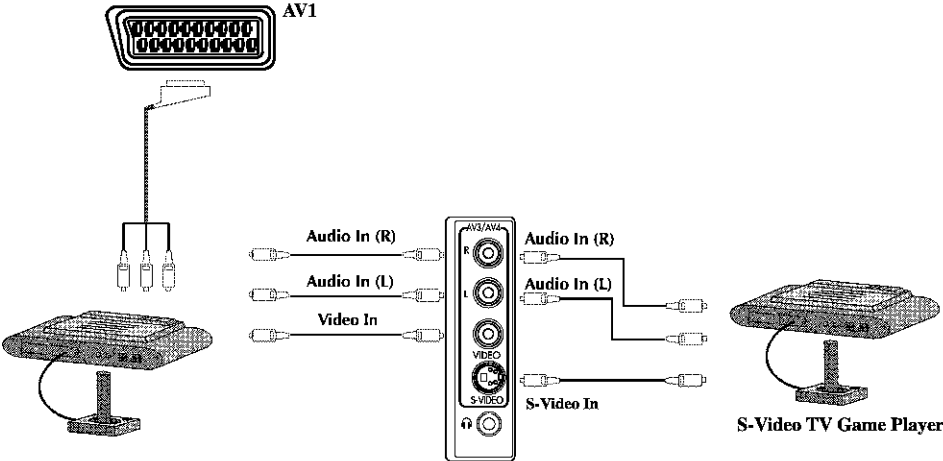

Help and service tips

The TV does not work

Make sure it is plugged into the mains supply and switched on.

Poor picture

- Is the aerial plugged in?
- If you are using a set top aerial is it properly aligned for the best signal.
- Make sure the aerial is not too close to neon lights, loudspeakers etc.
- Try changing the direction of the outdoor aerial. High buildings and mountains can cause ghost pictures or double images.
- The picture quality may be reduced by connecting two external sources at once. Disconnect one of the sources.
- Adjust the fine tuning.

No picture

- Is the aerial plugged in properly?
- Is the aerial lead damaged?
- Are all the plugs in the aerial lead fitted correctly?
- Have you pressed the correct buttons on the remote control?

No sound

- Is the sound muted? Press the Mute button.
- Is the volume turned down?
- Are there headphones connected?

Sound coming from only one speaker

- Is the balance set to one side? See the sound menu.
- If you have external speakers, has one of them become disconnected.

No response to the remote control

- Try changing the batteries.
- Is there an obstruction between the remote control and the sensor on the TV.

If nothing works

If you have tried the above solutions and none seem to work, try switching the unit off and on again.

If this does not work contact your supplier or TV repair technician. Never attempt to repair a defective TV yourself.

Symptoms	Solutions												
	Check if on/off switch is "on"	Try a different channel, if OK, probably station trouble	Check aerial connections on back of set	Check aerial for broken wires	Re orientate aerial	Probably local interference, such as an appliance	Adjust fine tuning control	Adjust brightness control	Adjust contrast control	Check if station is broadcasting colour	Adjust colour control	Check batteries in the remote control handset.	Switch the TV set OFF and ON from mains
No picture, no sound	✓	✓	✓	✓	✓	✓	✓	✓	✓	✓	✓	✓	✓
Poor sound, picture OK													
Poor Picture, sound OK		✓	✓	✓	✓	✓	✓	✓	✓	✓	✓	✓	✓
Weak picture		✓	✓	✓	✓	✓	✓	✓	✓	✓	✓	✓	✓
Blurred picture		✓	✓	✓	✓	✓	✓	✓	✓	✓	✓	✓	✓
Double image		✓	✓	✓	✓	✓	✓	✓	✓	✓	✓	✓	✓
Lines in picture		✓	✓	✓	✓	✓	✓	✓	✓	✓	✓	✓	✓
Distorted picture		✓	✓	✓	✓	✓	✓	✓	✓	✓	✓	✓	✓
Weak reception on some channels		✓	✓	✓	✓	✓	✓	✓	✓	✓	✓	✓	✓
Horizontal bars			✓	✓	✓	✓	✓	✓	✓	✓	✓	✓	✓
Picture rolls vertically		✓	✓	✓	✓	✓	✓	✓	✓	✓	✓	✓	✓
Poor colour		✓	✓	✓	✓	✓	✓	✓	✓	✓	✓	✓	✓
No colour		✓	✓	✓	✓	✓	✓	✓	✓	✓	✓	✓	✓
Remote control not working												✓	✓
TV does not accept any command												✓	✓
Teletext rolling up/down												✓	✓

22.1 CHASSIS BLOCK DIAGRAM

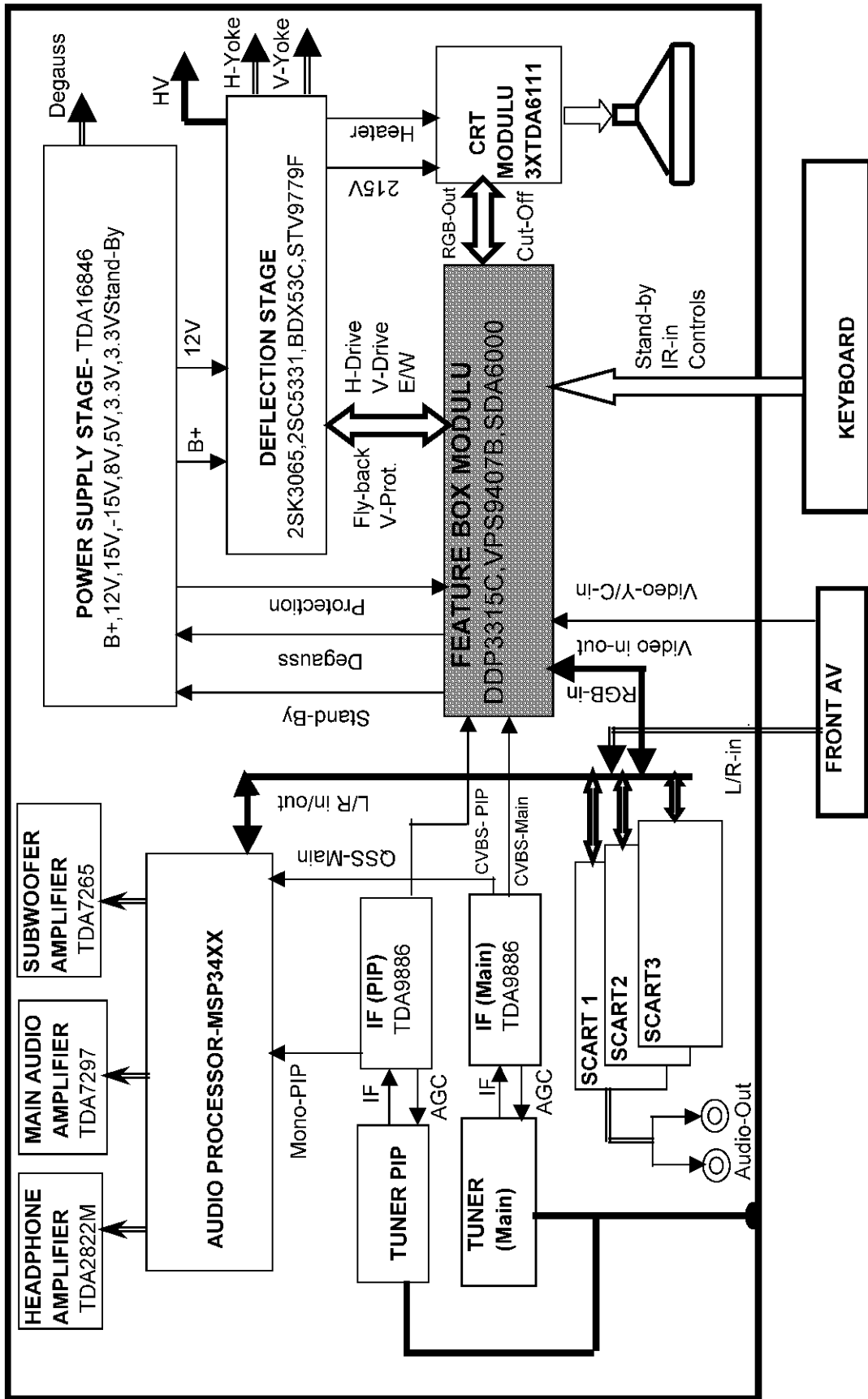

74LVC04A

Hex Inverter

FEATURES

- 5 V tolerant inputs for interfacing with 5 V logic
- Wide supply voltage range from 1.2 to 3.6 V
- CMOS low power consumption
- Direct interface with TTL levels
- Inputs accept voltages up to 5.5 V
- Complies with JEDEC standard no. 8-1A
- Specified from -40 to +85 °C and -40 to +125 °C.

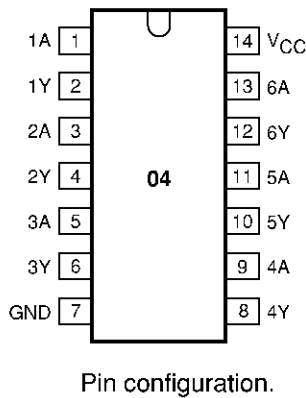

DESCRIPTION

The 74LVC04A is a high-performance, low-power, low-voltage, Si-gate CMOS device, superior to most advanced CMOS compatible TTL families.

Inputs can be driven from either 3.3 or 5 V devices. This feature allows the use of these devices as translators in a mixed 3.3 and 5 V environment.

The 74LVC04A provides six inverting buffers.

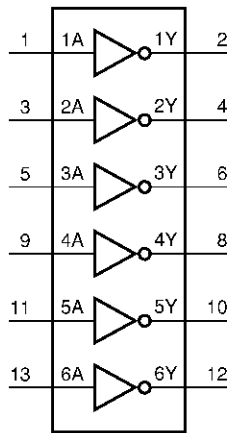

Logic symbol.

FAN117A

Features

- Low dropout voltage
- Load regulation: 0.05% typical
- Trimmed current limit
- On-chip thermal limiting
- Standard SOT-223, TO-220, and TO-252 packages
- Three-terminal adjustable or fixed 1.8V, 2.5V, 2.85V, 3.3V, 5V

Applications

- Active SCSI terminators
- High efficiency linear regulators
- Post regulators for switching supplies
- Battery chargers
- 12V to 5V linear regulators
- Motherboard clock supplies

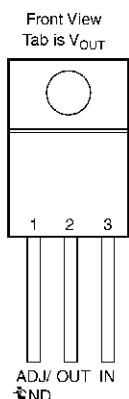

1A Adjustable/Fixed Low Dropout Linear Regulator

Description

The FAN117A and FAN117A-1.8, -2.5, -2.85, -3.3 and -5 are low dropout three-terminal regulators with 1A output current capability. These devices have been optimized for low voltage where transient response and minimum input voltage are critical. The 2.85V version is designed specifically to be used in Active Terminators for SCSI bus.

Current limit is trimmed to ensure specified output current and controlled short-circuit current. On-chip thermal limiting provides protection against any combination of overload and ambient temperatures that would create excessive junction temperatures.

Unlike PNP type regulators where up to 10% of the output current is wasted as quiescent current, the quiescent current of the FAN117A flows into the load, increasing efficiency.

The FAN117A series regulators are available in the industry-standard SOT-223, TO-220, and TO-252 (DPAK) power packages.

HY57V641620HG

4 Banks x 1M x 16Bit Synchronous DRAM

FEATURES

- Single 3.3±0.3V power supply
- All device pins are compatible with LVTTTL interface
- JEDEC standard 400mil 54pin TSOP-II with 0.8mm of pin pitch
- All inputs and outputs referenced to positive edge of system clock
- Data mask function by UDQM or LDQM
- Internal four banks operation
- Auto refresh and self refresh
- 4096 refresh cycles / 64ms
- Programmable Burst Length and Burst Type
 - 1, 2, 4, 8 or Full page for Sequential Burst
 - 1, 2, 4 or 8 for Interleave Burst
- Programmable $\overline{\text{CAS}}$ Latency ; 2, 3 Clocks

Pin Description

PIN	PIN NAME	DESCRIPTION
CLK	Clock	The system clock input. All other inputs are registered to the SDRAM on the rising edge of CLK
CKE	Clock Enable	Controls internal clock signal and when deactivated, the SDRAM will be one of the states among power down, suspend or self refresh
$\overline{\text{CS}}$	Chip Select	Enables or disables all inputs except CLK, CKE and DQM
BA0,BA1	Bank Address	Selects bank to be activated during $\overline{\text{RAS}}$ activity Selects bank to be read/written during $\overline{\text{CAS}}$ activity
A0 ~ A11	Address	Row Address : RA0 ~ RA11, Column Address : CA0 ~ CA7 Auto-precharge flag : A10
$\overline{\text{RAS}}$, $\overline{\text{CAS}}$, $\overline{\text{WE}}$	Row Address Strobe, Column Address Strobe, Write Enable	$\overline{\text{RAS}}$, $\overline{\text{CAS}}$ and $\overline{\text{WE}}$ define the operation Refer function truth table for details
LDQM, UDQM	Data Input/Output Mask	Controls output buffers in read mode and masks input data in write mode
DQ0 ~ DQ15	Data Input/Output	Multiplexed data input / output pin
VDD/VSS	Power Supply/Ground	Power supply for internal circuits and input buffers
VDDQ/VSSQ	Data Output Power/Ground	Power supply for output buffers
NC	No Connection	No connection

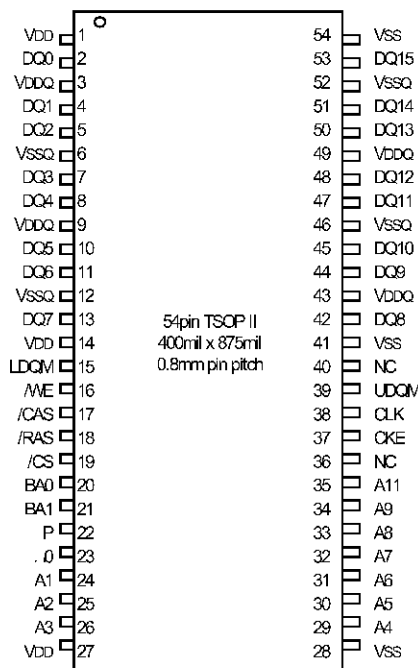

Pin Configuration

LD 1086

1.5A Low Drop Fixed And Adjustable Positive Voltage Regulators

- TYPICAL DROPOUT VOLTAGE 1.3V AT 1.5A
- THREE TERMINAL ADJUSTABLE OR FIXED OUTPUT VOLTAGE 1.8V, 2.5V, 2.85V, 3.3V, 3.6V, 5V, 8V, 9V, 12V
- GUARANTEED OUTPUT CURRENT UP TO 1.5A
- OUTPUT TOLERANCE $\pm 1\%$ AT 25°C AND $\pm 2\%$ IN FULL TEMPERATURE RANGE
- INTERNAL POWER AND THERMAL LIMIT
- WIDE OPERATING TEMPERATURE RANGE -40°C TO 125°C
- PACKAGE AVAILABLE: TO-220, D²PAK, D²PAK/A, DPAK,
- PINOUT COMPATIBILITY WITH STANDARD ADJUSTABLE VOLTAGE REGULATORS

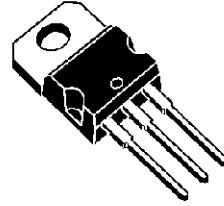

DESCRIPTION

The LD1086 is a LOW DROP Voltage Regulator able to provide up to 1.5A of Output Current. Dropout is guaranteed at a maximum of 1.5V at the maximum output current, decreasing at lower loads. The LD1086 is a pin compatible with older 3-terminal adjustable regulators, but has better performances in term of drop and output tolerance. A 2.85V output version is suitable for SCSI-2 active termination. Unlike PNP regulators, where a part of the output

current is wasted as quiescent current, the LD1086 quiescent current flow into the load, so increase efficiency. Only a 10 μ F minimum capacitor is needed for stability.

NCP1117

1.0A Low-Dropout Positive Fixed And Adjustable Voltage Regulators

The NCP1117 series are low dropout positive voltage regulators that are capable of providing an output current that is in excess of 1.0 A with a maximum dropout voltage of 1.2 V at 800 mA over temperature. This series contains eight fixed output voltages of 1.5 V, 1.8 V, 2.0 V, 2.5 V, 2.85 V, 3.3 V, 5.0 V, and 12 V that have no minimum load requirement to maintain regulation. Also included is an adjustable output version that can be programmed from 1.25 V to 18.8 V with two external resistors. On chip trimming adjusts the reference/output voltage to within $\pm 1.0\%$ accuracy. Internal protection features consist of output current limiting, safe operating area compensation, and thermal shutdown. The NCP1117 series can operate with up to 20 V input. Devices are available in SOT-223 and DPAK packages.

Features

- Output Current in Excess of 1.0 A
- 1.2 V Maximum Dropout Voltage at 800 mA Over Temperature
- Fixed Output Voltages of 1.5 V, 1.8 V, 2.0 V, 2.5 V, 2.85 V, 3.3 V, 5.0 V, and 12 V
- Adjustable Output Voltage Option
- No Minimum Load Requirement for Fixed Voltage Output Devices
- Reference/Output Voltage Trimmed to $\pm 1.0\%$
- Current Limit, Safe Operating and Thermal Shutdown Protection
- Operation to 20 V Input

Applications

- Consumer and Industrial Equipment Point of Regulation
- Active SCSI Termination for 2.85 V Version
- Switching Power Supply Post Regulation
- Hard Drive Controllers
- Battery Chargers



(Top View)

- Pin: 1. Adjust/Ground
2. Output
3. Input

TDA6111Q

Video Output Amplifier

FEATURES

- High bandwidth and high slew rate
- Black-current measurement output for Automatic Black-current Stabilization (ABS)
- Two cathode outputs; one for DC currents, and one for transient currents
- A feedback output separated from the cathode outputs
- Internal protection against positive appearing Cathode-Ray Tube (CRT) flashover discharges
- ESD protection
- Simple application with a variety of colour decoders
- Differential input with a designed maximum common mode input capacitance of 3 pF, a maximum differential mode input capacitance of 0.5 pF and a differential input voltage temperature drift of 50 $\mu\text{V/K}$
- Defined switch-off behaviour.

GENERAL DESCRIPTION

The TDA6111Q is a video output amplifier with 16 MHz bandwidth. The device is contained in a single in-line 9-pin medium power (DBS9MPF) package, using high-voltage DMOS technology, intended to drive the cathode of a colour CRT.

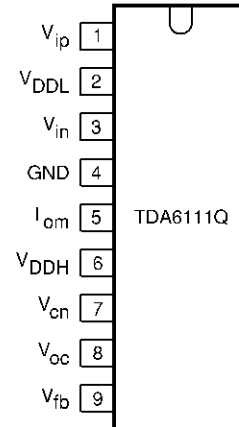

Pin configuration.

PINNING

SYMBOL	PIN	DESCRIPTION
V_{ip}	1	non-inverting voltage input
V_{DDL}	2	supply voltage LOW
V_{in}	3	inverting voltage input
GND	4	ground, substrate
I_{om}	5	black current measurement output
V_{DDH}	6	supply voltage HIGH
V_{cn}	7	cathode transient voltage output
V_{oc}	8	cathode DC voltage output
V_{fb}	9	feedback voltage output

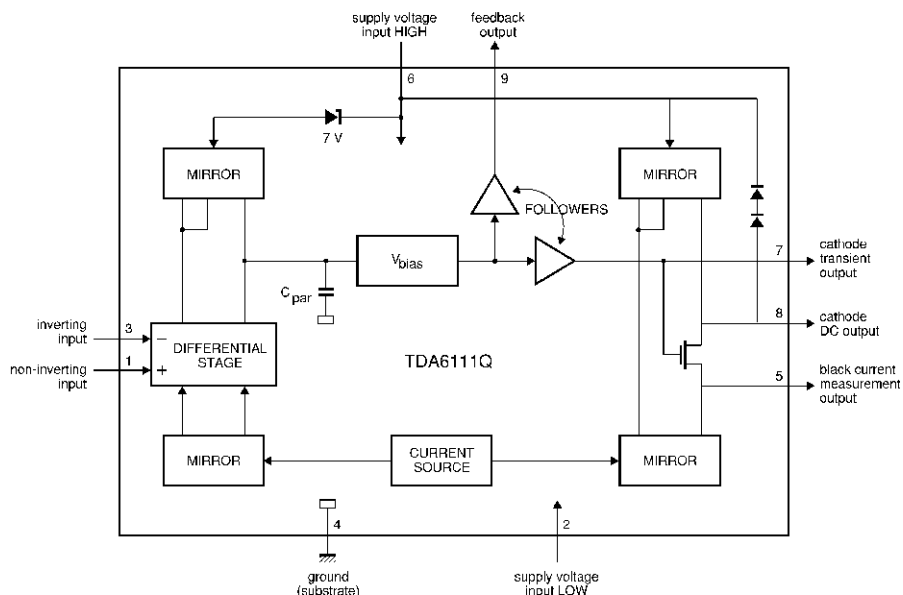

Features**General**

- Level 1.5, 2.5, 3.5 WST Display Compatible
- Fast External Bus Interface for SDRAM (Up to 8 MByte) and ROM or Flash-ROM (Up to 2 x 4 MByte)
- Embedded General Purpose 16 Bit CPU (Also used as TV-System Controller, C16x Compatible)
- Display Generation Based on Pixel Memory
- Program Code also Executable From External SDRAM
- Embedded Refresh Controller for External SDRAM
- Enhanced Programmable Low Power Modes
- Single 6 MHz Crystal Oscillator
- Multinorm H/V-Display Synchronization in Master or Slave Mode
- Free Programmable Pixel Clock from 10 MHz to 50 MHz
- Pixel Clock Independent from CPU Clock
- 3 x 6 Bits RGB-DACs On-Chip
- Supply Voltage 2.5 and 3.3 V
- P-MQFP-128 Package

Microcontroller Features

- 16-bit C166-CPU Kernel (C16x Compatible)
- 60 ns Instruction Cycle Time
- 2 KBytes Dual Ported IRAM
- 2 KBytes XRAM On-chip
- General Purpose Timer Units (GPT1 and GPT2).
- Asynchronous/Synchronous Serial Interface (ASC0) with IrDA Support. Full-duplex Asynchronous Up To 2 MBaud or Half-duplex Synchronous up to 4.1 MBaud.
- High-speed Synchronous Serial Interface (SSC). Full- and Half-duplex synchronous up to 16.5 Mbaud
- 3 Independent, HW-supported Multi Master/Slave I²C Channels at 400 Kbit/s
- 16-Bit Watchdog Timer (WDT)
- Real Time Clock (RTC)
- On Chip Debug Support (OCDS)
- 4-Channel 8-bit A/D Converter
- 42 Multiple Purpose Ports
- 8 External Interrupts
- 33 Interrupt Nodes

Display Features

- OSD size from 0 to 2046 (0 to 1023) pixels in horizontal (vertical) direction
- Frame Buffer Based Display
- 2 HW Display Layers
- Support of Double Page Level 2.5 TTX in 100 Hz Systems
- Support of Transparency for both Layers Pixel by Pixel
- User Programmable Pixel Frequency from 10.0 MHz to 50 MHz
- Up to 65536 Displayable Colors in one Frame

- DMA Functionality
- Graphic Accelerator Functions (Draw Lines, Draw and Fill Rectangle, etc.)
- 1, 2, 4 or 8-bit Bitmaps (up to 256 out of 4096 colors)
- 12 bit/16 bit RGB Mode for Display of up to 65535 Colors
- HW-support for Proportional Characters
- HW-support for Italic Characters
- User Definable Character Fonts
- Fast Blanking and Contrast Reduction Output
- Double resolution graphic for interlaced sync rasters (SDA6001 only)

Acquisition Features

- Two Independent Data Slicers (One Multistandard Slicer + one WSS-only Slicer)
- Parallel Multi-norm Slicing (TTX, VPS, WSS, CC, G+)
- Four Different Framing Codes Available
- Data Caption only Limited by available Memory
- Programmable VBI-buffer
- Full Channel Data Slicing Supported
- Fully Digital Signal Processing
- Noise Measurement and Controlled Noise Compensation
- Attenuation Measurement and Compensation
- Group Delay Measurement and Compensation
- Exact Decoding of Echo Disturbed Signals

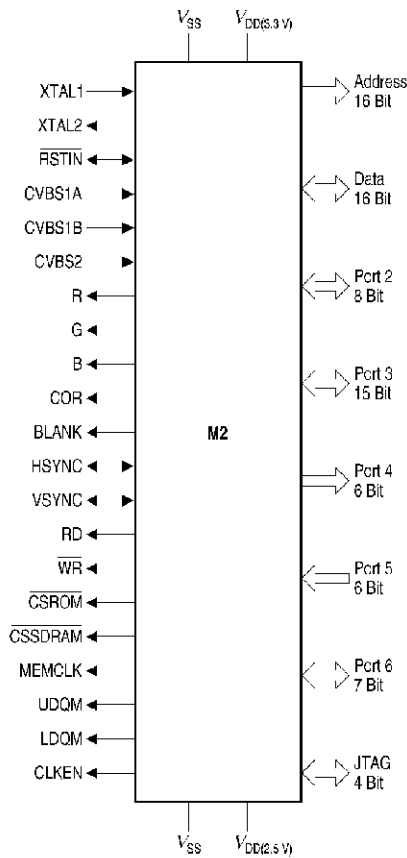

Pin Diagram (top view)

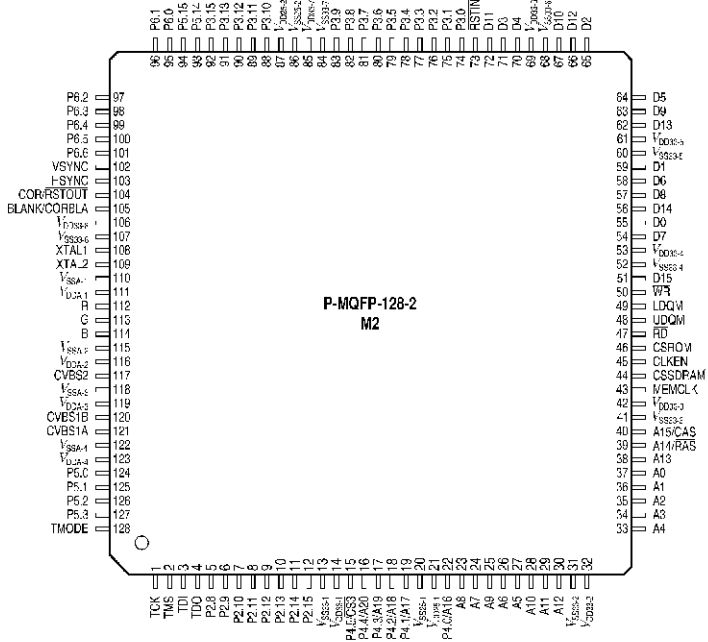

SDA 6000

Pin No	Pin Name	Type	Function
38, 37, 36, 35, 34, 33, 30, 29, 28, 27, 26, 25, 24, 23	From A13 to A0	Output	Address bit/SDRAM address bit
39	A14	Output	Address bit/Row address strobe for SDRAM access
40	A15	Output	Address bit/Column address strobe for SDRAM access
55, 59, 65, 71, 70, 64, 58, 54, 57, 63, 67, 72, 66, 62, 56, 51	From D0 to D15	Input/Output	Data bit
47	RD	Output	External memory read strobe for ROM. RD is activated for every external instruction or data access.
46	CSROM	Output	Chip select signal for ROM device.
44	CSSDRAM	Output	Chip select signal for SDRAM device.
43	MEMLCK	Output	Clock for SDRAM
45	CLKEN	Output	Enable for memory clock
50	WR	Output	Memory write strobe
109	XTAL2	Output	Output of the oscillator amplifier circuit
108	XTAL1	Input	Input of the oscillator amplifier circuit
73	RSTIN	Input	Reset input pin
121	CVBS1A	Input	CVBS signal inputs for full service data slicing
120	CVBS1B	Input	Ground for CVBS1A (Differential input)
117	CVBS2	Input	CVBS signal inputs for WSS data slicing
112	R	Output	Analog output for red channel
113	G	Output	Analog output for green channel
114	B	Output	Analog output for blue channel
104	COR	Output	Output for contrast reduction /Reset output
105	BLANK	Output	Fast blanking signal/Three-level signal for contrast reduction + fast blanking
103	HSYNC	Input	Horizontal sync Input
102	VSYNC	Input	Vertical sync Input
74	SCL0	Output	I2C Bus Clock line 0
75	SDA0	Output	I2C Bus Data line 0
76	IR	Input	Connect to pin 1 of the Keyboard module
77	LED	Input/Output	Connect to pin 3 of the Keyboard module
78, 79, 80	KEY 3/2/1	Input	Connect to pin 5/6/7 of the Keyboard module
81	MSP_RESET	Output	Reset signal for the MSP 3410G
92	STAND-BY	Output	Stand-by ON/OFF signal output.
124	PROT	Input	Protection signal input.
125	STATUS3	Input	Switching signal comes from pin 8 of the SCART3
126	STATUS2	Input	Switching signal comes from pin 8 of the SCART2
127	STATUS1	Input	Switching signal comes from pin 8 of the SCART2
97	FIELD	Output	Field signal of field detection.
98	SCL1	Input/Output	I2C Bus Clock line 1
99	SDA1	Input/Output	I2C Bus Data line 1
101	RESET_FBOX	Output	Reset signal for the IC DDP3315C.
110	VSSA_1	Supply	Analog ground
111	VDDA_1	Supply	Analog power (2.5V) (for PLL and DAC)
115, 118, 122	VSSA2_4	Supply	Analog ground
116, 119, 123	VDDA2_4	Supply	Analog power (2.5V) (for ADCs)
20, 86	VSS25_1_2	Supply	Digital ground (for digital core)
21, 87	VDD25_1_2	Supply	digital power (2.5V) (for digital core)
13, 31, 41, 52, 60, 68, 84, 107	VSS33_1_8	Supply	Digital ground for pads
14, 32, 42, 53, 61, 69, 85, 106	VDD33_1_8	Supply	Digital power (3.3V) (for pads)

SDA 6000

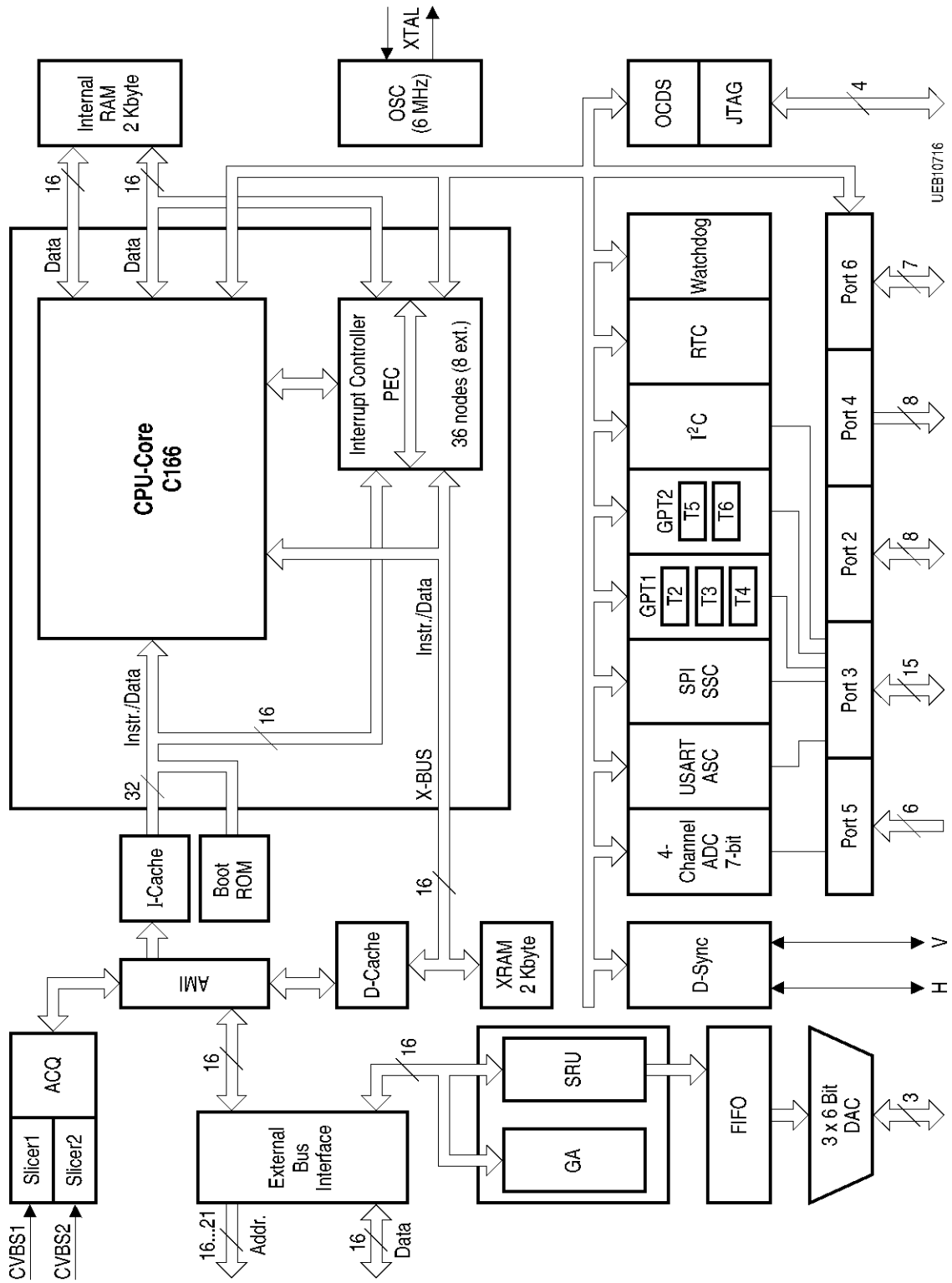

Architectural Overview

DDP 3315C

Display and Deflection Processor

Introduction

The DDP 3315C is a mixed-signal single-chip digital display and deflection processor, designed for high-quality backend applications in double scan and HDTV TV sets with 4:3 or 16:9 picture tubes. The interfaces qualify the IC to be combined with state of the art digital scan rate converters, as well as analog HDTV sources. The DDP 3315C contains the entire digital video component, deflection processing, and all analog interfaces to display the picture on a CRT. The main features are

Video Processing

- linear horizontal scaling (0.25 ... 4), as well as nonlinear horizontal scaling "panorama vision"
- dynamic black level expander
- luma sharpness enhancement by dynamic peaking and luma transient improvement (LTI)
- color transient improvement (CTI)
- programmable RGB matrix
- black stretch, blue stretch, gamma correction via programmable Non-linear Colorspace Enhancer (NCE) on RGB
- two analog double scan inputs with fast blank (one RGB and one RGB/YC_rC_b/YP_rP_b selectable)

- average and peak beam current limiter
- automatic picture tube adjustment (cutoff, drive)

Deflection Processing

- scan velocity modulation output
- digital EHT compensation for vertical / east-west
- vertical angle and bow correction
- differential vertical outputs
- vertical zoom via deflection adjustment
- horizontal and vertical protection circuit
- horizontal frequency for VGA/SVGA/1080i
- black switch off procedure
- supports horizontal and vertical dynamic focus

Miscellaneous

- selectable ITU-R 601 4:1:1 / 4:2:2 YC_rC_b input at 27/32 MHz or double scan ITU-R 656 input at 54 MHz line-locked clock
- crystal oscillator for horizontal safety
- picture frame generator
- hardware for simple 50/60 Hz to 100/120 Hz conversion (display frequency doubling)
- PQFP80 package, 5 V analog and 3.3 V digital supply

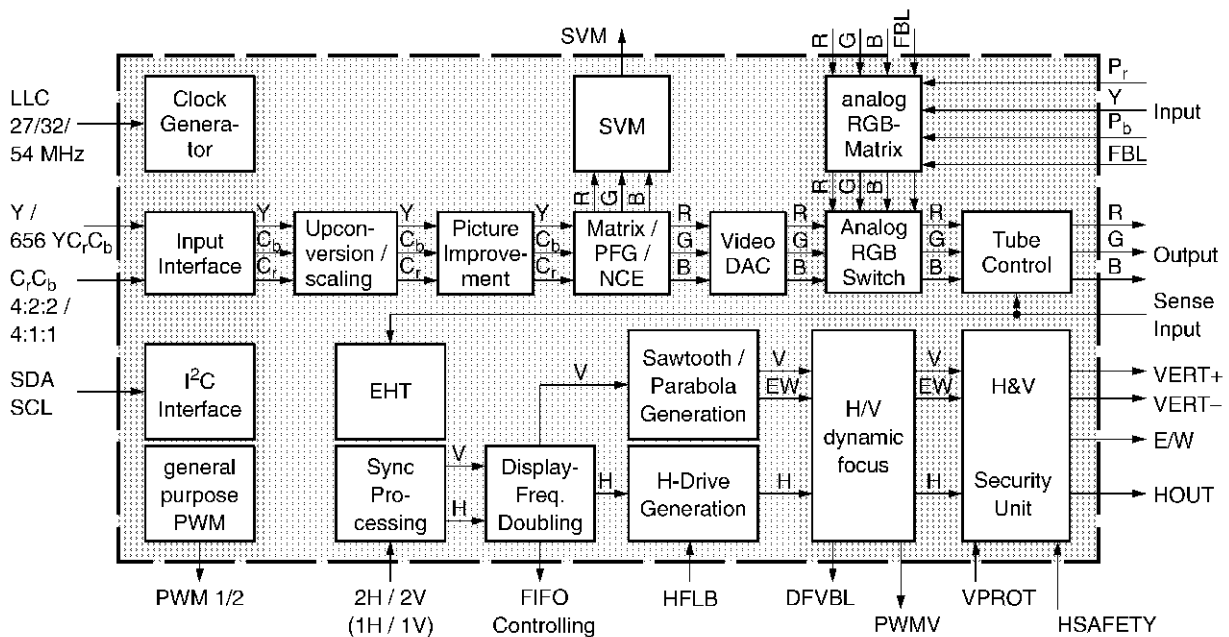

VSP 94x7B

General Description

The VSP 94xxB (OPTIMUS) is a new component of the Micronas MEGAVISION® single-chip-IC family. The VSP 94xxB family comprises all main functions of a digital featurebox in one monolithic IC. The amount of features is splitted up to different levels from mid to high end, always giving highest picture quality. The family is ideally suited to work in conjunction with the deflection processors SDA 9380, DDP3310B or DDP3315C (dependent on 94xxB version). In combination with the 'digital TV decoder' MDE 9500 double-scan IDTV are possible. 50/60Hz derivatives are also available. The device comprises digital multistandard color decoder for master and slave channel, a RGB interface with fast-blank capability (SCART), scaling units including panorama, embedded DRAM for upconversion, high performance frame based upconversion algorithms, picture improvements, temporal noise reduction as well as A/D and D/A converter.

Features

- **Different Application modes**
 - FSM: frame based high performance master with PIP
 - SSC: Split screen ('Double Window')
 - MUP: Multi pictures, several still and 2 live pictures possible
 - PC: PC signal in combination with TV signal (TV in PC or PC in TV)
- **Data Acquisition connectivity**
 - Up to seven (9425B/9427B: nine) CVBS inputs, up to two Y/C inputs,
 - Up to three CVBS outputs (even when Y/C input)
 - ITU-R 656 compatible digital input
 - RGB/FBL or YUV or YUV-H-V input
 - 9 bit amplitude resolution for CVBS/Y/C A/D converter
 - 8 bit amplitude resolution for RGB/FBL A/D converter
- **Multi-standard color decoder with 4H comb-filter**
 - PAL/NTSC/SECAM including all substandards
 - Automatic recognition of chroma standard
 - AGC (Automatic Gain Control)
- **Second Multi-standard color decoder for slave channel (94x7B only)**
- **Processing of two input channels independently: master and slave channel**
- **Motion adaptive temporal noise reduction for master and slave channel**
 - Field or frame based temporal noise reduction for luminance and chrominance
- **Pre-Scaling of the 1f_H signal (master and slave channel)**
 - horizontal scaling factors: 1.5...[2 pixel resolution]...1/28
 - vertical scaling factors: 1...[1 line resolution]...1/30
- **Horizontal and vertical scaling of the 2f_H signal (master and slave channel)**
 - Horizontal Scaling factors: 3...[2 pixel resolution]...0.75
 - 5 zone horizontal panorama generator
- **Vertical scaling of the 2f_H signal (master channel)**
 - Vertical Scaling factors: 0.92...[2 line resolution]...8
 - 5 zone vertical panorama generator
- **Detection circuits**
 - Global motion and global still detection
 - Film mode and phase detection (PAL, NTSC; 2-2, 3-2 pull down)
 - measurement of the noise level (blanking)
 - measurement of the noise level (inside active picture)
 - detection of letter box formats
- **Embedded memory**
 - On-chip memory controller
 - Embedded DRAM core for field memory
 - SRAM for delay lines
- **Data format 4:2:2**
- **Read or write of memory content via 656 interface**
- **Data slicer for closed caption ('V-chip') and WSS**
- **Flexible clock and synchronization concept**
 - Horizontal line-locked or free-running mode
 - Vertical locked or free-running mode
- **Scan-rate-conversion (version dependent)**
 - Motion adaptive frame based 100/120 Hz interlaced scan rate conversion
 - Motion adaptive frame based 50/60 Hz progressive scan rate conversion
 - Special treatment for film material ('Inverse 3-2 pull down')
 - Large area and line flicker reduction
 - Simple progressive modes: AB, AA*
 - Simple interlaced modes (100/120 Hz): ABAB, AABB, AAAA, BBBB
 - No scan-rate-conversion modes (50/60 Hz): AB, AA, BB
- **Signal manipulations**
 - Still field or still frame
 - Insertion of colored background
 - 2D and 3D frames for master and slave channel
 - Snapshot
 - Windowing
 - Temporal overblending between master and slave
 - Vertical chrominance shift for improved VCR picture quality
 - Mosaic-mode generator
 - Test pattern generator
 - Demo mode
- **Sharpness improvement**
 - Digital color transition improvement (DCTI)
 - Adaptive horizontal and vertical Peaking (luminance)
 - Digital luminance transition improvement (DLTI)
 - Digital contrast improvement (DCI, master channel only)
- **(S) VGA support**
 - synchronization to external (S)VGA source possible
 - scaling of VGA picture, including TV picture and VGA display 'side-by-side'
- **Three D/A converters**
 - 9 bit amplitude resolution for YUV, RGB output
 - (nominal) 72 MHz clock frequency with two-fold oversampling
- **Digital output (version dependent)**
 - 4:4:4 YUV or RGB output with 24 or 27 bit
 - 4:2:2 YUV output with 24 or 27 bit
 - 2f_H-8bit (656 like) digital output
 - ITU-R 656 compatible digital output
- **I²C-bus control (400 kHz)**
- **1.8V± 5% and 3.3V ± 5% supply voltages**
- **P-MQFP-80 or P-MQFP-144 package**
- **Only one crystal necessary for whole IC and all color standards**

VSP 94x7B

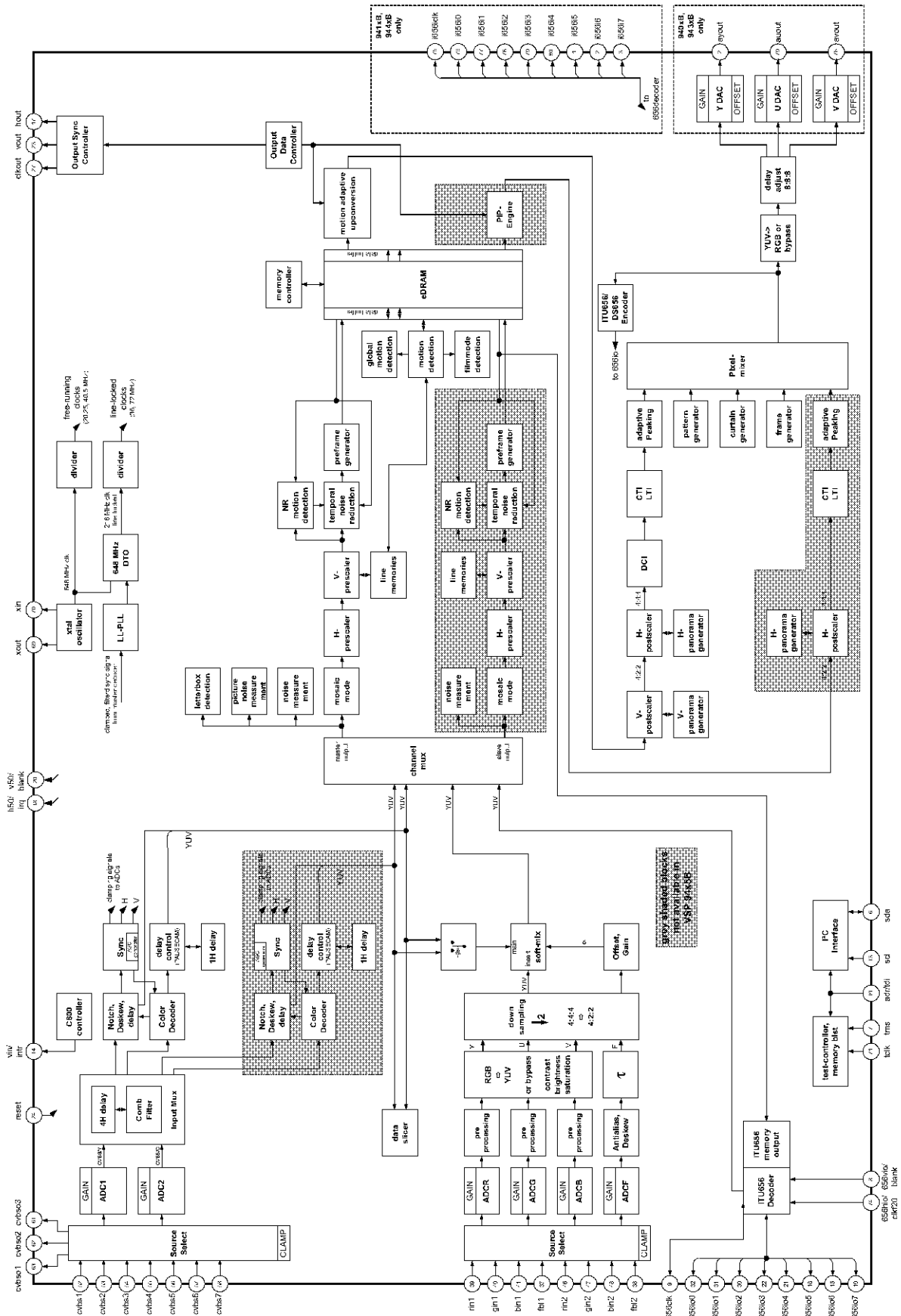

VSP 94x7B

Pin No	Pin Name	Type	Function
52	CVBS1	Input	CVBS input (analog input)
53	CVBS2	Input	CVBS input (analog input)
54	CVBS3	Input	CVBS input (analog input)
55	CVBS4	Input	CVBS input or Y1 (analog input)
56	CVBS5	Input	CVBS input or C1 (analog input)
57	CVBS6	Input	CVBS input or Y2 (analog input)
58	CVBS7	Input	CVBS input or C2 (analog input)
63	CVBSOUT1	Output	CVBS output 1 (analog output)
62	CVBSOUT2	Output	CVBS output 2 (analog output)
61	CVBSOUT3	Output	CVBS output 3 (analog output)
70	XIN	Input	Crystal connection 1
69	XOUT	Output	Crystal connection 2
23	VOOUT	Output	Vertical output
17	HOOUT	Output	Horizontal output
1	VDDDACY	Supply	Supply DAC (Y) (3.3 V)
3	VSSDACY	Supply	Supply DAC (Y) (0 V)
78	VDDDACU	Supply	Supply DAC (U) (3.3 V)
80	VSSDACU	Supply	Supply DAC (U) (0 V)
75	VDDDACV	Supply	Supply DAC (V) (3.3 V)
77	VSSDACV	Supply	Supply DAC (V) (0 V)
2	AYOUT	Output	Luminance output (analog out put)
79	AUOUT	Output	Chrominance output (analog output)
76	AVOUT	Output	Chrominance output (analog output)
39	RIN1	Input	R or V IN1
40	GIN2	Input	G or Y IN1
41	BIN3	Input	B or U IN1
37	FBL1	Input	Fast blanking input 1 (H1) (analog input)
46	RIN2	Input	R or V IN2 (analog input)
47	GIN2	Input	G or Y IN2 (analog input)
48	BIN2	Input	B or U IN2 (analog input)
38	FBL2	Input	Fast blanking input 2 (H2) (analog input)
6	SDA	Input/Output	I2C - Bus data
13	SCL	Input	I2C - Bus clk
7	TMS	Input	Testmode select
24	RESET	Input	Reset input
27	CLKOUT	Output	Output clock (27 MHz)
59	VDD33C	Supply	Supply voltage CVBS (3.3 V)
60	VSS33C	Supply	Supply voltage CVBS (0 V)
50	VDDAC1	Supply	Supply voltage CVBS1 (1.8 V)
51	VSSAC1	Supply	Supply voltage CVBS1 (0 V)
64	VDDAC2	Supply	Supply voltage CVBS2 (1.8 V)
65	VSSAC2	Supply	Supply voltage CVBS2 (0 V)
44	VDD33RGB	Supply	Supply voltage RGB (3.3 V)
45	VSS33RGB	Supply	Supply voltage RGB (0 V)
42	VDDARGB	Supply	Supply voltage for RGB (1.8 V)
43	VSSARGB	Supply	Supply voltage for RGB (0 V)
35	VDDAFBL	Supply	Supply voltage for FBL (1.8 V)
36	VSAFBL	Supply	Supply voltage for FBL (0 V)
68	VDDAPLL	Supply	Supply voltage for PLL (1.8 V)
66, 5, 28, 34	VDDD	Supply	Supply voltage for digital (1.8 V)
67, 4, 29, 33, 73,11, 26	VSSD	Supply	Supply Voltage for digital (0 V)
72, 12, 25	VDDP	Supply	Supply voltage for digital (3.3 V)
32, 31, 30, 22, 21, 16, 15, 10	656IO0	Output	Digital output
9	656CLK	Output	Digital output clock
74	656HIO	Input	Separate H input for 656
8	656VIO	Input	Separate V input for 656

TDA 7265

25+25 W Amplifier with Mute and Stand-by

- WIDE SUPPLY VOLTAGE RANGE (UP TO $\pm 25V$ ABS MAX.)
- SPLIT SUPPLY
- HIGH OUTPUT POWER
25 + 25W @ THD = 10%, $R_L = 8\Omega$, $V_S = \pm 20V$
- NO POP AT TURN-ON/OFF
- MUTE (POP FREE)
- STAND-BY FEATURE (LOW I_q)
- SHORT CIRCUIT PROTECTION
- THERMAL OVERLOAD PROTECTION

DESCRIPTION

The TDA7265 is class AB dual Audio power amplifier assembled in the Multiwatt package, specially designed for high quality sound application as Hi-Fi music centers and stereo TV sets.

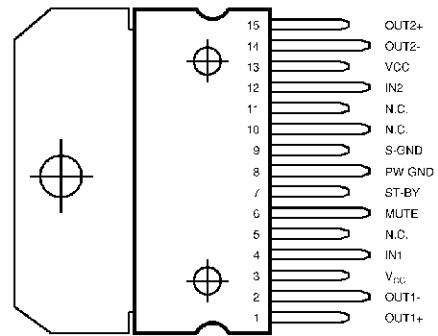
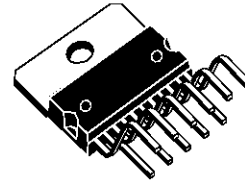

PIN CONNECTION

TDA 7297

15+15W Dual Bridge Amplifier

- WIDE SUPPLY VOLTAGE RANGE (6V -18V)
- MINIMUM EXTERNAL COMPONENTS
 - NO SWR CAPACITOR
 - NO BOOTSTRAP
 - NO BOUCHEROT CELLS
 - INTERNALLY FIXED GAIN
- STAND-BY & MUTE FUNCTIONS
- SHORT CIRCUIT PROTECTION
- THERMAL OVERLOAD PROTECTION

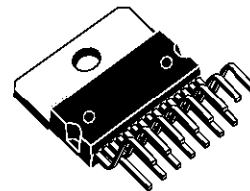

TDA9886

FEATURES

- 5 V supply voltage
- Gain controlled wide-band Vision Intermediate Frequency (VIF) amplifier, AC-coupled
- Multistandard true synchronous demodulation with active carrier regeneration: very linear demodulation, good intermodulation figures, reduced harmonics, and excellent pulse response
- Gated phase detector for L and L-accent standard
- Fully integrated VIF Voltage Controlled Oscillator (VCO), alignment-free, frequencies switchable for all negative and positive modulated standards via I²C-bus
- Digital acquisition help, VIF frequencies of 33.4, 33.9, 38.0, 38.9, 45.75, and 58.75 MHz
- 4 MHz reference frequency input: signal from Phase-Locked Loop (PLL) tuning system or operating as crystal oscillator
- VIF Automatic Gain Control (AGC) detector for gain control, operating as peak sync detector for negative modulated signals and as a peak white detector for positive modulated signals
- External AGC setting via pin OP1
- Precise fully digital Automatic Frequency Control (AFC) detector with 4-bit digital-to-analog converter, AFC bits readable via I²C-bus
- TakeOver Point (TOP) adjustable via I²C-bus or alternatively with potentiometer
- Fully integrated sound carrier trap for 4.5, 5.5, 6.0, and 6.5 MHz, controlled by FM-PLL oscillator
- Sound IF (SIF) input for single reference Quasi Split Sound (QSS) mode, PLL controlled

FUNCTIONAL DESCRIPTION

1. VIF amplifier
2. Tuner AGC and VIF-AGC
3. VIF-AGC detector
4. Frequency Phase-Locked Loop (FPLL) detector
5. VCO and divider
6. AFC and digital acquisition help
7. Video demodulator and amplifier
8. Sound carrier trap
9. SIF amplifier
10. SIF-AGC detector
11. Single reference QSS mixer
12. AM demodulator
13. FM demodulator and acquisition help
14. Audio amplifier and mute time constant
15. Internal voltage stabilizer
16. I²C-bus transceiver and MAD (module address).

I²C- Bus controlled single and multistandard Alignment-free IF-PLL demodulators

- SIF-AGC for gain controlled SIF amplifier, single reference QSS mixer able to operate in high performance single reference QSS mode and in intercarrier mode, switchable via I²C-bus
- AM demodulator without extra reference circuit
- Alignment-free selective FM-PLL demodulator with high linearity and low noise
- I²C-bus control for all functions
- I²C-bus transceiver with pin programmable Module Address (MAD)
- Four I²C-bus addresses via MAD.

2 GENERAL DESCRIPTION

The TDA9885 is an alignment-free multistandard (PAL and NTSC) vision and sound IF signal PLL demodulator for negative modulation only and FM processing.

The TDA9886 is an alignment-free multistandard (PAL, SECAM and NTSC) vision and sound IF signal PLL demodulator for positive and negative modulation, including sound AM and FM processing.

3 APPLICATIONS

- TV, VTR, PC and STB applications.

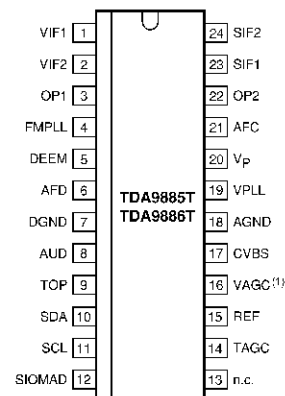

Pin configuration

TDA9886

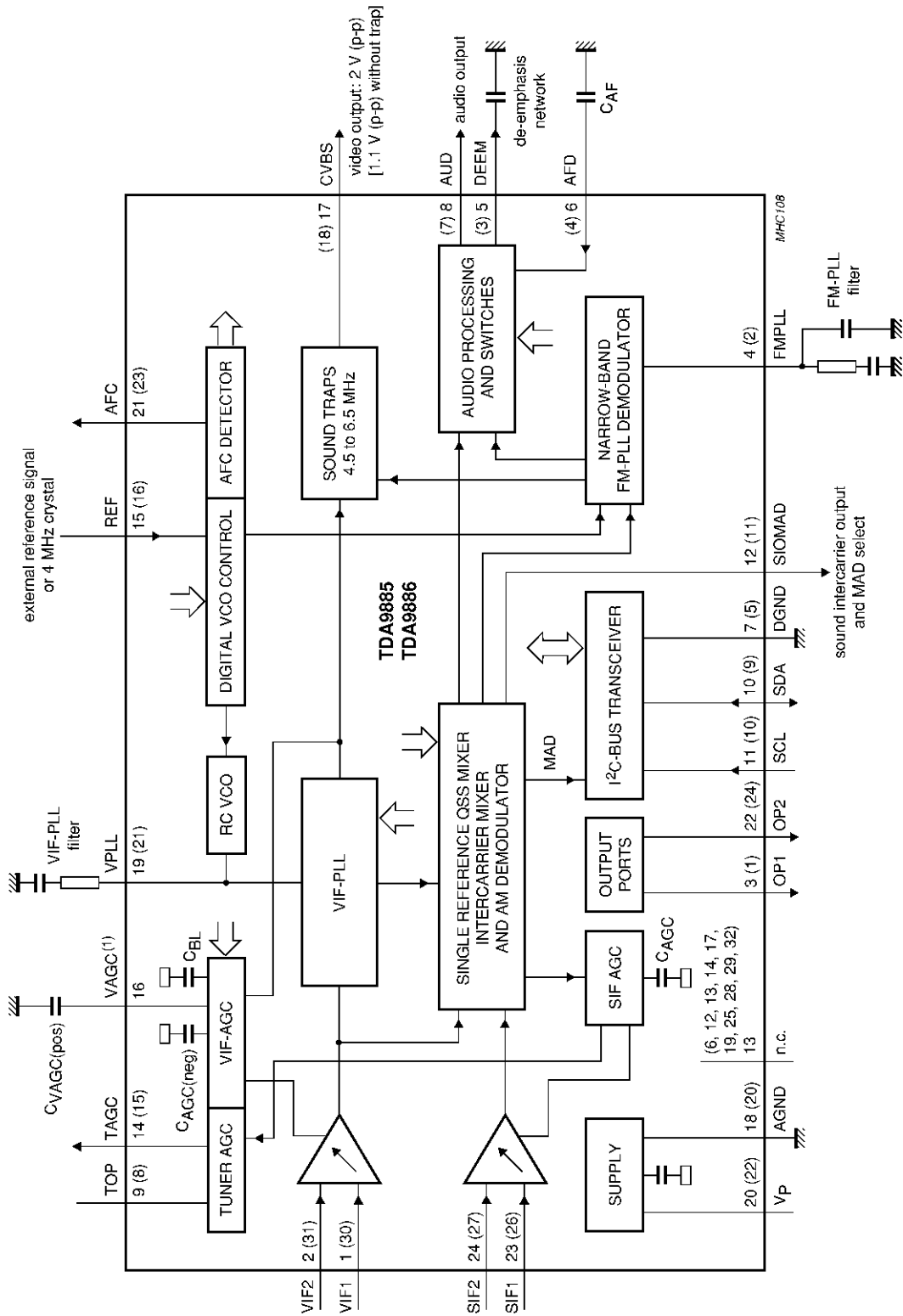

Block diagram.

TDA9886

SYMBOL	PIN	DESCRIPTION
	TDA9886T TDA9886TS	
VIF1	1	VIF differential input 1
VIF2	2	VIF differential input 2
n.c.	–	not connected
OP1	3	output port 1; open-collector
FMPLL	4	FM-PLL for loop filter
DEEM	5	de-emphasis output for capacitor
AFD	6	AF decoupling input for capacitor
DGND	7	digital ground
n.c.	–	not connected
AUD	8	audio output
TOP	9	tuner AGC TakeOver Point (TOP) for resistor adjustment
SDA	10	I ² C-bus data input and output
SCL	11	I ² C-bus clock input
SIOMAD	12	sound intercarrier output and MAD select with resistor
n.c.	–	not connected
n.c.	13	not connected
n.c.	–	not connected
TAGC	14	tuner AGC output
REF	15	4 MHz crystal or reference signal input
VAGC	16	VIF-AGC for capacitor
n.c.	–	not connected
CVBS	17	composite video output
n.c.	–	not connected
AGND	18	analog ground
VPLL	19	VIF-PLL for loop filter
V _P	20	supply voltage
AFC	21	AFC output
OP2	22	output port 2; open-collector
n.c.	–	not connected
SIF1	23	SIF differential input 1 and MAD select with resistor
SIF2	24	SIF differential input 2 and MAD select with resistor
n.c.	–	not connected
n.c.	–	not connected

1. ELECTRICAL ADJUSTMENTS

1.1 Supply Voltage Adjustment

Connect a digital voltmeter to the cathode of diode D607 at the AV mode of the TV and set the screen voltage to the minimum with the screen potentiometer. Adjust the main supply voltage (B+) with P601 potentiometer to the following value. (After supply adjustment , readjust Screen and focus voltage)

- 28" : 145 VDC (For A66EAK071X44)
- 29" Pure Flat : 130 VDC (For A68QCP891X232)
- 32" 16:9 Pure Flat : 125 VDC (For W76EKW10X71)
- 33" : 145 VDC (For A80AEJ10X522)

2. SERVICE ADJUSTMENTS

2.1 Video Adjustment

- Apply a signal with FUBK or Philips test pattern.
- Enter the service menu with service the remote control or with the user R/C (When main menu appears, enter "9301")
- Select the VIDEO ADJUSTMENTS option.
- Adjust BCL GAIN, BCL TRESHOLD , BCL TRESHOLD 16:9, BCL TIME CONSTANT1, BCL TIME CONSTANT2, OSD BRIGHTNESS, OSD CONTRAST, TXT BRIGHTNESS to the following values, are given in Table 1.
- Adjust the values of YC DELAY FOR PAL , YC DELAY FOR SECAM, YC DELAY FOR NTSC to "0" .
- Adjust " SUBCARRIER ADJ." to the level where colour bar is pure and also "SUBCARRIER INDICAT." is VALID.

NOTE 1: Do not allow to change the values of SUBCARRIER DEV. and SUBCARRIER INDICAT .

NOTE 2: Do not enter anyt value to EEPROM EDIT, PRESET and I2C CHECK REPORT titles.

- PRESET title is used get back to the factory mode adjustmenst.
- I2C CHECK REPORT is used to read the data from I2C line.
- EEPROM EDIT is used to send the data to any adress in the Eeprom or to read the data from the Eeprom.
- Exit from the service menu with the service R/C or with the user R/C (with TV/TXT button on the R/C).

2.2 Background Adjustment

- Enter the service menu with the service R/C or the user R/C.
- Select the COLOURS menu.
- Adjust BLUEBACK Y to "0",
Adjust BLUEBACK U to "3",
Adjust BLUEBACK V to "0",
Adjust CURTAIN Y to "0",
Adjust CURTAIN U to "1",

Adjust CURTAIN V to “ 0” ,
 Adjust MULTIPICTURE Y to “4” ,
 Adjust MULTIPICTURE U to “ 0” ,
 Adjust MULTIPICTURE V to “ 0” ,
 Adjust PIP FRAME Y to “ 0” ,
 Adjust PIP FRAME U to “ 0” ,
 Adjust PIP FRAME V to “ 2” ,
 Adjust FRAME Y to “0” ,
 Adjust FRAME U to “ 2” ,
 Adjust FRAME V to “ 0” .

- Exit from the service menu with the service R/C or with the user R/C (with TV/TXT button on the R/C).

2.3 Screen Adjustment

- Enter the service menu with service the remote control or with the user R/C (When main menu is selected, enter “ 9301”)
- Select the VIDEO ADJUSTMENTS menu.
- Find the SCREEN ADJ. option with P+/P- button and adjust it to “ 0 “ with V+/V- button.
- Press “ OK” button from the service R/C or the user R/C. At the momet, the screen will be black and a line will be visiable in the middle of the screen.
- Adjust the screen potantiometer to the level where the screen is just black and the line is just visiable)
- By pressing “OK” button , the picture will appear again. (Screen is switched to Off)
- Exit from the service menu with the service R/C or with the user R/C (with TV/TXT button on the R/C).

2.4 AGC Adjustment

- Enter the service menu with the service R/C or the user R/C.
- Select the IF ADJUSTMENTS title.
- Adjust AGC 1 VHFIII-UHF to “ 15” and AGC 1 VHFI to “ 20” .
- Adjust the value of AGC 2 VHFIII-UHF to the same value of AGC 1 VHFIII-UHF . (“ 15”)
 (This adjustment is valid for PIP versions.)
- Adjust the value of AGC 2 VHFI to the same value of AGC 1 VHFI . (“ 20 “)
 (This adjustment is also valid for PIP versions.)
- Exit from the service menu with the service R/C or with the user R/C (with TV/TXT button on the R/C).

NOTE 3: AGC 2 VHFIII-UHF and AGC 2 VHFI titles are used to AGC adjustment of PIP tuner. If the set do not contain the PIP specification, these items are not used.

2.5 Geometry Adjustment

There are two different Geometry adjustment memories for PAL/SECAM and NTSC systems in this chassis.

- 100 Hz GEOMETRY ADJUSTMENTS are used for PAL/SECAM systems.
- 120 Hz GEOMETRY ADJUSTMENTS are used for NTSC systems.

NOTE 4: Both PAL and NTSC geometry adjustments must be completed for all of the versions.

2.5.1 PAL /SECAM Geometry Adjustment

- Apply a FUBK or Philips Test Pattern to the antenna input.
- Enter the service menu with service the remote control or with the user R/C (When main menu appears, enter "9301")
- Select 100 Hz Geometry Adjustments "
- Adjust TILT to " 127 " .
- Adjust VERTICAL ZOOM, EHT TRESHOLD , EHT TIME CONSTANT, VERTICAL EHT1 , VERTICAL EHT 2, HORIZONTAL EHT 1 , HORIZONTAL EHT 2 to the values which are given **Table 1**.
- Adjust Vertical amplitude with " VERTICAL AMPLITUDE " .
Adjust Vertical position with " VERTICAL SHIFT " .
Adjust Vertical linearity with " LINEARITY " .
Adjust Vertical correction with " S_CORRECTION " .
Adjust Vertical parallel with " VERTICAL ANGLE " .
Adjust Vertical curved line with " VERTICAL BOW " .
Adjust Horizontal position with " HORIZONTAL SHIFT " .
Adjust Horizontal general parabola with " CUSHION CORRECTION " .
Adjust Upper corner parabola with " UPPER CORNER 1" and " UPPER CORNER 2 " .
Adjust Lower corner parabola with " LOWER CORNER 1 " and " LOWER CORNER 2 " .
Adjust Horizontal position of OSD with " HOR.OSD POSITION " .
Adjust Vertical position of OSD with " VER.OSD POSITION " .
Adjust Horizontal width with " HORIZONTAL WIDTH " . If the adjustment field is not enough, the value of Horizontal width has to be adjusted to " 255 " . After that, the value of EHT TRESHOLD is decreased and horizontal width adjustment has been completed.
- Exit from the service menu with the service R/C or with the user R/C (with TV/TXT button on the R/C).

2.5.2 NTSC System Geometry Adjustment

- Apply a NTSC signal to scart 1 (AV1) from a pattern generator with FUBK or Philips test pattern.
- Enter the service menu with service the remote control or with the user R/C (When the main menu appears, enter "9301")
- Select 120 Hz Geometry Adjustments "
- NTSC system Geometry adjustments will be done as PAL/SECAM system Geometry adjustments as mentioned above.
- Exit from the service menu with the service R/C or with the user R/C (with TV/TXT button on the R/C).

2.6 Feature Options

SCART3	: Yes (AVAILABLE) or No (NOT AVAILABLE)
FRONT AV	: NOT AVAILABLE CVBS&SVHS AVAIAABLE ONLY CVBS AVAILABLE ONLY SVHS AVAILABLE
TELETEXT	: TEXT (Default) FASTEXT TOPTXT FASTEXT&TOPTXT
TXT TABLE	: AUTO(Selecting TXT table according to menu language automaticly) NOT (Default AUTO) West, East, Greec, Cyrillic, Arabic, Farsi, Hebrew
LANGUAGE	: Used for select the menu language. A (English,German,French,Itailan, Spanish,Portugal, Dutch, Greek, Danish, Swiss, Finnish, Norwegian, Turkish, Hebrew, Russian, Hungary, Slovenian,Slovak, Czech) B (English,German,French,Itailan, Dutch, Greek, Danish, Swiss, Turkish, Hebrew, Russian, Hungary, Slovenian, Slovak, Czech, Croatian, Romanian,Bulgarian)
MAIN TUNER	: Used to select the Main Tuner. (Philips,Panasonic DB2G3, Temic, Panasonic D44G3, Sharp or Alps)
PIP TUNER	: Used to select the PIP Tuner. (Philips,Panasonic DB2G3, Temic, Panasonic D44G3, Sharp or Alps)
DEGAUSS	: NOT AVAILABLE (Degauss is selected from the User menu) 1-15 SECOND (Degauss timer adjustment - It will be adjusted to 5 seconds)
BLUE BACK	: NOT AVAILABLE AVAILABLE VIA MENU (Blue Back function can be selected from the user menu)
CURTAIN	: YES (Blue back function is ON at the interval programs .This feature is valid when the P+/P- button is used on the user R/C) NO (Blue back function is OFF at the interval programs)
BG	: Yes (AVAILABLE) or No (NOT AVAILABLE)
DK	: Yes (AVAILABLE) or No (NOT AVAILABLE)
I	: Yes (AVAILABLE) or No (NOT AVAILABLE)
L/L'	: Yes (AVAILABLE) or No (NOT AVAILABLE)
NICAM	: Yes (AVAILABLE) or No (NOT AVAILABLE)
DOLBY VIRTUAL	: Yes (AVAILABLE) or No (NOT AVAILABLE)
SUBWOOFER	: Yes (AVAILABLE) or No (NOT AVAILABLE)
HEADPHONE	: Yes (AVAILABLE) or No (NOT AVAILABLE)
DYNAMIC BASS	: Yes (AVAILABLE) or No (NOT AVAILABLE) Default (DYNAMIC BASS has to be selected as NOT AVAILABLE in the products with Subwoofer feature.) NOTE 5: When the DYNAMIC BASS is "ON" on the user Menu for the Subwoofer versions, SUBWOOFER is also " ON" automatically.
LTI	: ON (Default), OFF VIA MENU(Luminance Transient Improvement can be selected from the User menu)
CTI	:ON (Colour Transient Improvement), OFF VIA MENU (Default) (Luminance transient improvement can be selected from the User menu)

- CRT : 4:3 (For 4:3 CPT)
16:9 (For 16:9 CPT)
- PIP : Yes (AVAILABLE) or No (NOT AVAILABLE)
- SVM : Scan Velocity Modulation . ON, OFF (Default)
VIA MENU (SVM can be selected from the User menu)
NOTE 6: SVM is not available in this chassis. This feature will be selected " ON" as default till is supported by the chassis.
- TILT : AVAILABLE (Correct slant of picture function is ON)
NOT AVAILABLE (Default)
NOTE 7: TILT is not available in this chassis. This feature will be selected " NOT AVAIABLE" as default till is supported by the chassis.
- CARRIER MUTE : VIA MSP (For other countries)
VIA MICRO (For local country)
- COMB FILTER : ON (Default), OFF
VIA MENU (COMB FILTER can be selected from the User menu)

2.7 Factory Settings for Service Mode

1. Values given in Table 1 are typical values and can vary according to the CRT type.
2. Values given in Table 2 are typical values and can vary according to the CRT type and the frequency. (according to the 50 Hz or 60 Hz)
3. PF means Pure Flat and SF means Super Flat.

	28" 4:3	28" 16:9 PF	28" 16:9 SF	29" PF	32" 16:9 PF	33"
R.DRIVE	234	260	234	224	260	230
G.DRIVE	225	225	225	225	225	225
B.DRIVE	237	225	216	214	225	220
R.CUTOFF	399	320	288	350	320	350
G.CUTOFF	300	300	300	300	300	300
B.CUTOFF	282	255	292	325	255	325
BCL GAIN	500	500	500	500	500	450
BCL TRESHOLD	340	315	315	340	315	400
BCL TRESHOLD 16:9	50	150	150	50	150	150
SCREEN ADJ.	0	0	0	0	0	0
BCL TIME CONSTANT1	200	200	200	200	200	200
BCL TIME CONCTANT2	0	0	0	0	0	0
OSD BRIGHTNESS	128	128	128	128	128	200
TEXT BRIGTNES	0	0	0	128	0	127
OSD CONTRAST	400	400	400	400	400	500

Table 1

	100 HZ GEOMETRY						120 HZ GEOMETRY					
	28" 4:3	28" 16: 9 PF	28" 16: 9 SF	29" PF	32" 16: 9 PF	33"	28" 4:3	28" 16: 9 PF	28" 16: 9 SF	29" PF	32" 16: 9 PF	33"
VERTICAL AMP.	-298	-262	-428	-314	-384	-292	-296	-278	-418	-275	-375	-304
VERTICAL ZOOM	255	200	150	255	200	255	255	200	150	255	200	255
VERTICAL SHIFT	2	-2	3	-2	-2	3	-3	-5	0	-6	-3	0
LINEARITY	-12	-37	33	-40	-37	-10	5	-1	86	5	-1	-14
S-CORRECTION	145	85	85	180	85	100	125	175	175	125	175	109
VERTICAL ANGLE	10	1	2	0	1	6	5	0	-4	0	1	6
VERTICAL BOW	10	6	15	-3	-16	2	4	-6	23	4	-6	0
HORIZONTAL WIDTH	141	225	228	255	252	219	153	215	245	255	255	213
HORIZONTAL SHIFT	287	273	274	278	284	274	271	256	255	259	283	260
TRAPEZE CORREC.	-34	-68	-79	-46	-47	-55	1	-45	-22	-19	-42	-16
CUSHION CORREC.	-215	-189	-331	-205	-184	-242	-200	-217	-370	-210	-214	-261
UPPER CORNER 1	44	-9	-58	33	-4	12	72	32	72	20	92	136
LOWER CORNER 1	74	114	134	39	54	39	44	104	44	20	114	63
UPPER CORNER 2	8	51	34	4	74	20	-45	63	-45	-6	-45	-60
LOWER CORNER 2	- 8	-85	-21	33	45	22	-13	-13	-13	-23	-13	21
EHT TRESHOLD	10	10	10	10	10	10	10	10	10	10	10	10
EHT TIME CONST.	0	0	0	0	0	0	0	0	0	0	0	0
VERTICAL EHT 1	-100	-100	-100	-100	-100	-100	-100	-100	-100	-100	-100	-100
VERTICAL EHT 2	-50	-50	-50	-50	-50	-50	-50	-50	-50	-50	-50	-50
HORIZONTAL EHT 1	-450	-450	-450	-450	-450	-450	-450	-450	-450	-450	-450	-450
HORIZONTAL EHT 2	-40	-40	-40	-40	-40	-40	-40	-40	-40	-40	-40	-40
TILT	127	127	127	127	127	127	127	127	127	127	127	127
HOR.OSD POSITION	32	31	32	33	29	32	32	30	28	32	28	28
VER.OSD POSITION	6	4	5	5	4	4	6	0	0	0	0	0

Table 2

NOTE 8 : Values given Table 1 and Table 2 can be increased or decreased as 1 by 1, 10 by 10 or 100 by 100 with the service/user Remote Control .

- Vol +/- Vol - keys on the Remote Control are used to increase/decrease 1 by 1,
- 1 and 3 keys on the Remote Control are used to to increase/decrease 10 by 10,
- 4 and 6 keys on the Remote Control are used to to increase/decrease 100 by 100, values in the Table 1and Table 2.

WAVE FORMS

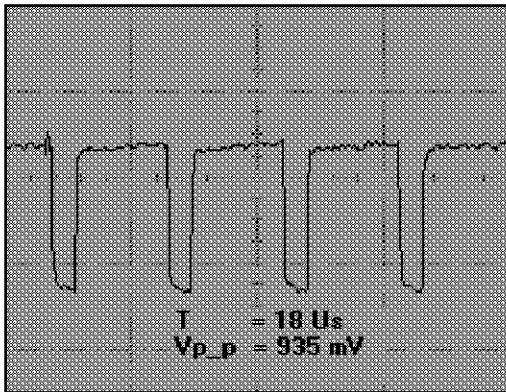

H_DRIVE
X205 PIN (2)- Std.by

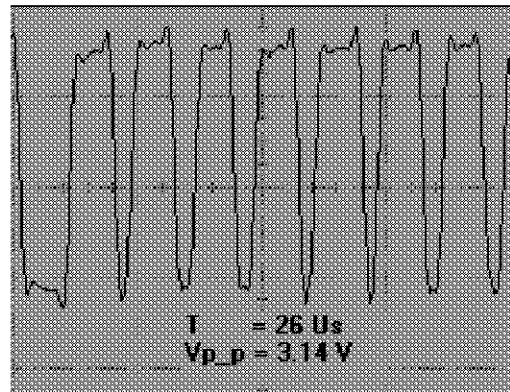

SCL 3_3
X204 PIN (17)

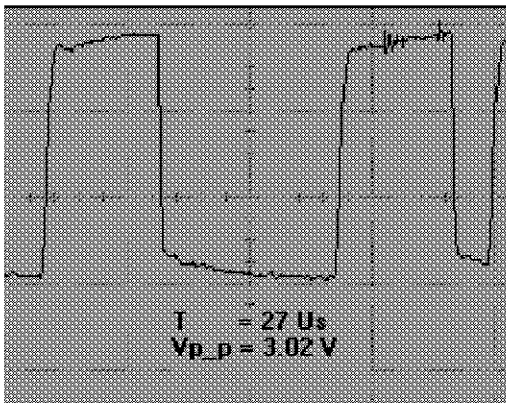

SDA 3_3
X204 PIN (18)

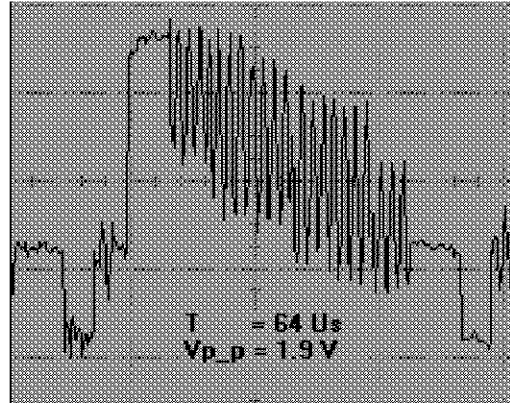

SC1 VID_OUT
X203 PIN (7)

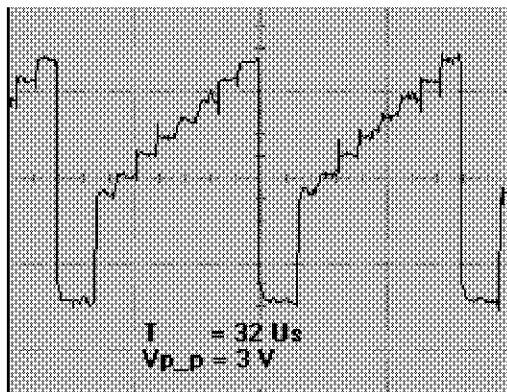

RED
X701 PIN (2)

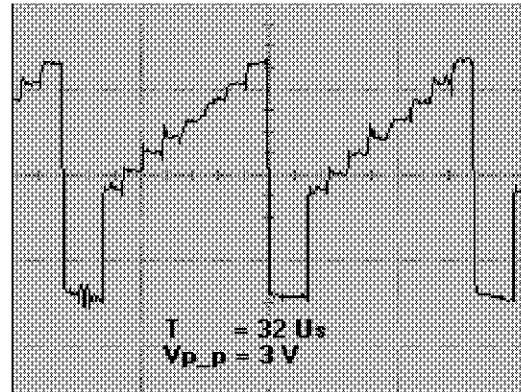

GREEN
X701 PIN (4)

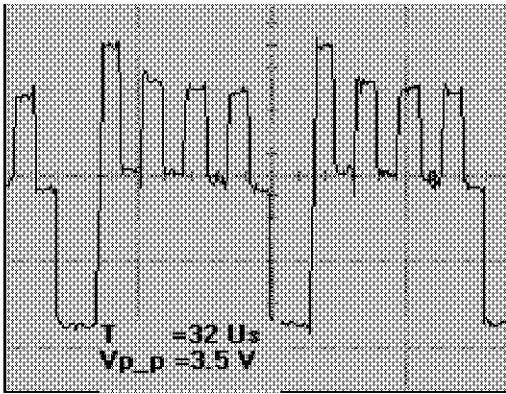

BLUE
X701 PIN (6)

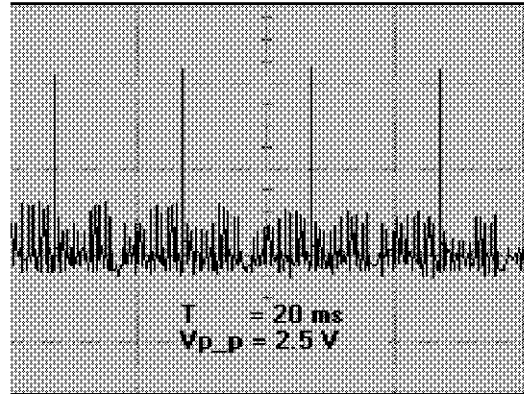

CUT OFF
X701 PIN (10)

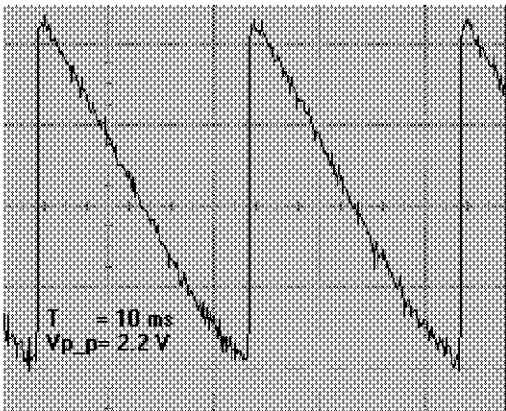

V_DRIVE (-)
X205 PIN (5)

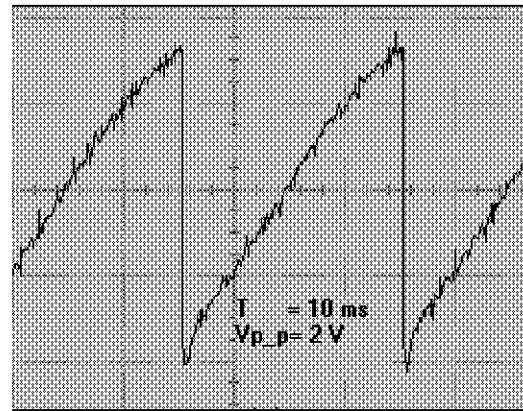

V_DRIVE (+)
X205 PIN (4)

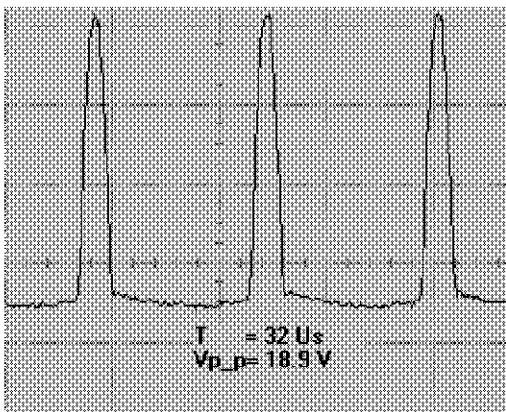

FLY_BACK
X205 PIN (2)

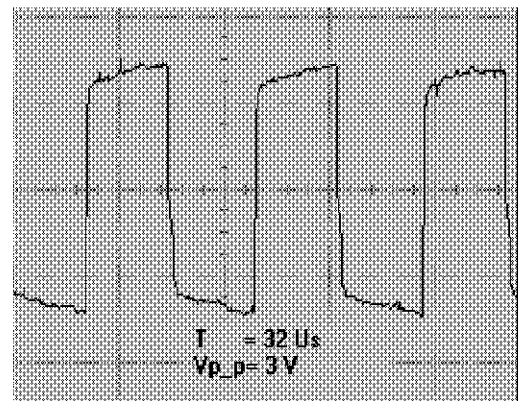

H_DRIVE
X205 PIN (3)

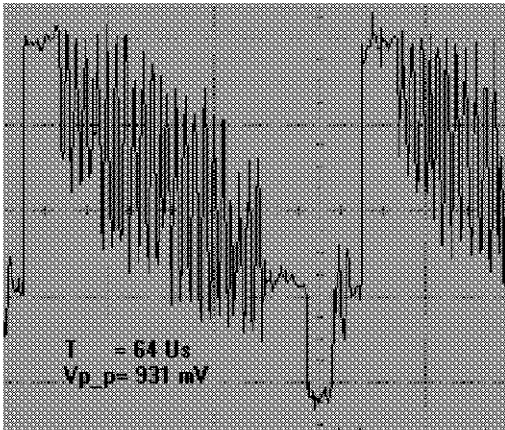

**CVBS_TUN1
X203 PIN (1)**

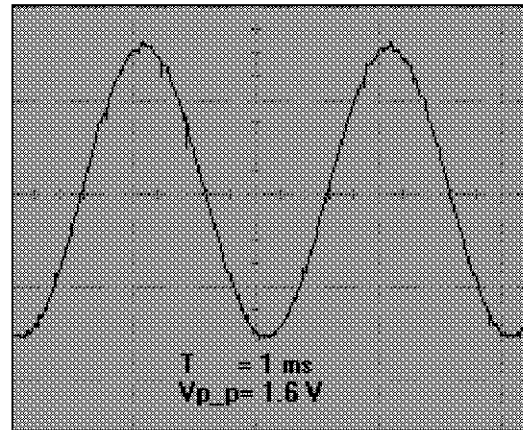

**MONO PIP
IC102 PIN (8)**

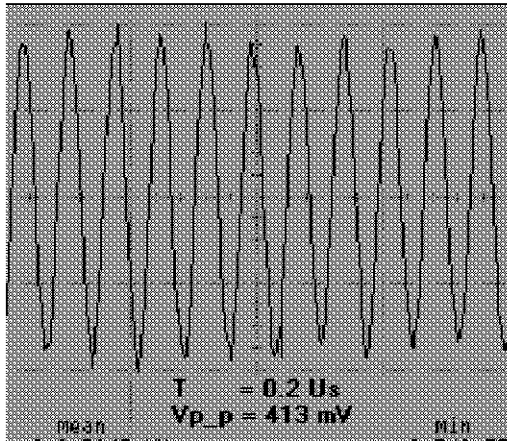

**QSS_TUN1
IC101 PIN (12)**

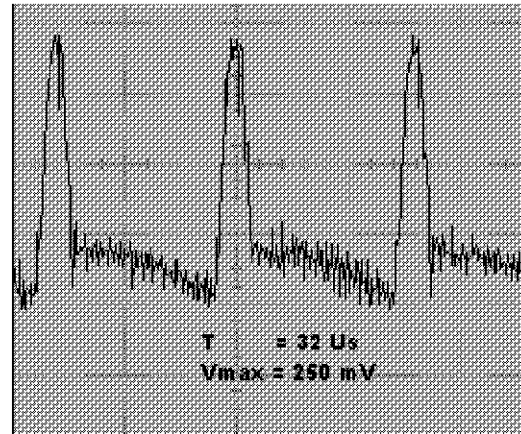

**HEATER
X504 PIN (2)**

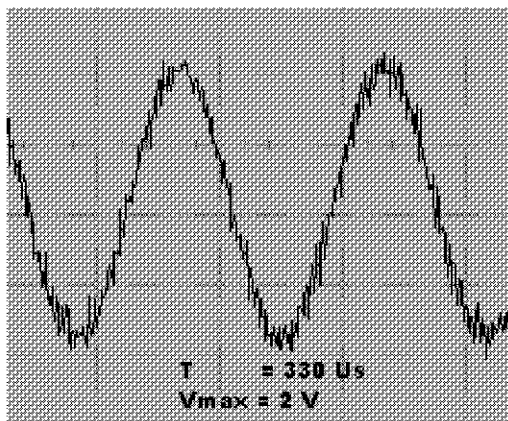

**L OUT
IC 301 PIN (29)**

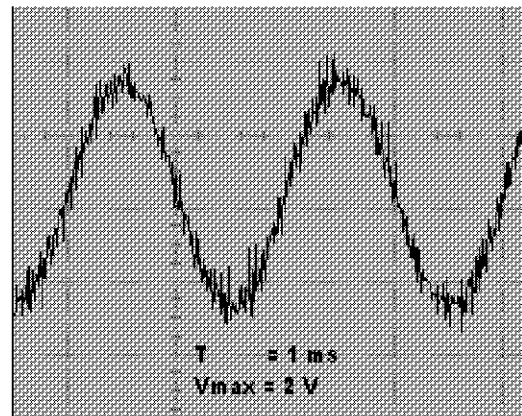

**R OUT
IC 301 PIN (28)**

PART LIST

PART NO	DESCRIPTION	NOTES	POSITION NUMBERS					
010840-01	TACT SW LONG STEN 2LEG							
010845	TACT SW WITH GREEN LED							
010845	TACT SW WITH GREEN LED							
010971	MAIN SWITCH GDE S40 4/100A-250V							
010712-03	POWER SWITCH S40 4/100A-250V S.BRAC.							
291101	CC-CHIP 100PF J 50V /1206 NPO		C02	C03				
290223	CC-CHIP 22PF J 50V /0603 NPO TAPE		C118	C142	C812	C830	C843	C844
294476	CC-CHIP 470NF K 16V /0805 X7R		C119	C138	C143	C218	C244	
252112	EC 100UF 16V 11*6 R:5		C217	C307	C312	C319	C322	C325
294111	CC-CHIP 100NF K 25V /0805 X7R		C328					
250105	EC 1UF 100V 11*5 R:5		C334	C523	C524			
251478	EC 47UF 16V 11*5 R:5		C402	C455	C456	C457	C801A	C807
251115	EC 10UF 25V 11*5 R:5		C425	C837	C874			
291476	CC-CHIP 470PF J 50V /0603 NPO		C502	C303	C304	C305	C306	C209
274102	C-PEM 100NF J 63V R:5		C505	C508	C513	C529		
274107	C-PEM 100NF J 100V R:5		C506					
274230	C-PEM 220NF J 100V R:5		C509					
252476	EC 470UF 25V 11*10 R:5		C512	C533	C537			
272154	C-PPM 1.5NF J 1600V R:15		C516					
273114	C-PPM 10NF J 1.5/1.6KV R:15 CLASS-B	28"	C517					
273122	C-PPM 11NF J 1.5/1.6KV R:15 ALASS-B	29" / 32"	C517					
273123	C-PPM 12NF J 1.5/1.6KV R:15 CLASS-B	33"	C517					
274563	C-PPM 560NF J 250V R:15 CLAAS-B		C518					
274330	C-PEM 330NF J 250V R:15		C520					
274684	C-PPM 680NF J 250V R:15 CLASS-B		C521					
273270	C-PPM 27NF J 400V R:15		C522					
293681	CC-CHIP 68NF K 25V /0805 X7R		C527					
273475	C-PEM 47NF K 100V R:5		C528					
252106	EC 100UF 63V 11*5.8 R:5		C534					
272110	C-PEM 1NF J 100V R:5		C540					
274238	C-PEM 220NF K 275V-AC R:15 CLASS-B		C601					
274341	C-PEM 330NF K 275V-AC R:15 CLASS-B		C602	C604				
274340	C-PEM 330NF K 275V-AC R:22.5 CLASS-B		C602	C604				
274108	C-PPM 100NF J 400V R:10		C603					
202220	CC 2.2NF M 250VAC Y5U R:10 AH/NSA		C606	C607	C623			
202105	CC 1NF K 1KV Y5P R:5		C608	C609	C610	C611		
203330	C-PPM 33NF J 630V R:15		C612					
252222	EC 220UF M 400V 40*25 R:10		C613					
201481	CC 470PF K 2KV +15%, -30% 105C R:5		C614					
292475	CC-CHIP 4.7NF K 50V /0603 X7R		C617	C618	C640			
271820	C-PEM 820PF J 100V R:5		C619					
201226	CC 220PF K 2KV Y5P R:5		C624					
252104	EC 100UF 200V 25*16 R:7.5		C625					
253106	EC 1000UF 25V 20*13 R:5		C630	C633				
253150	EC 1500UF 25V 20*13 R:5		C631	C327				
201220	CC 220PF K 500V R:5		C632	C657	C658	C530	C531	C536
252482	EC 470UF 16V 12.5*10 R:5		C701					
252229	EC 220UF 16V 11*8 R:5		C702					
259478	EC 4.7UF 250V 12*10 R:5		C703	C722	C730	C519		
274474	C-PEM 470NF J 63V R:5		C704					
209220	CC 2PF C 50V NPO R:5		C706	C711	C716			
273222	C-PEM 22NF K 250V R:7.5		C707	C712	C717			
273229	C-PEM 22NF K 100V R:5		C708	C710	C713	C715	C718	C720
202221	C-CE 2.2NF K 2KV Y5P R:7.5		C721	C723				
273225	C-PEM 22NF J 63V R:5		C740					
272101	C-PEM 1NF K 50V R:5		C781	C782	C784	C785		
294231	CC-CHIP 220NF K 16V /0805 X7R		C811	C873				
291104	CC-CHIP 100PF J 50V /0603 NPO		C831	C833	C869	C428	C439	C441

PART LIST

PART NO	DESCRIPTION	NOTES	POSITION NUMBERS
251120	EC 10UF 10V 5*4 R:5		C901
202106	CC 1NF K 50V Y5P R:5		C920 C921
292110	CC-CHIP 1NF K 50V /0805 X7R		C921 C922 C923
202102	C-CEA 1NF K 50V R:10		C922 C923
273471	C-PEM 47NF K 63V R:5		C940 C941
303991	LED IR SIR563SB3F 23/940		D01
303993	LED LTL4221N D:3 R/D RED		D02
303223	DIODE-CHIP BA682 SOD80		D101
303195	DIODE 4148 MELF		D401 D402 D801 D802 D803 D804
303215	DIODE RGP10G		D503
300305	DIODE BA157		D504 D507 D509
302316	DIODE FFPF60B150DS		D505
303216	DIODE RGP15G		D508 D510
303308	DIODE RF2007		D601 D602 D603 D604
303214	DIODE UF4006		D605 D705
302317	DIODE BYT56M		D607
302319	DIODE BYW29F-150		D609 D608
303813	DIODE RGP15D		D611 D501
302947	DIODE 1N4004		D612 D617
302289	DIODE 1N4148 52MM		D701 D502 D506 D511 D613 D606
303942	LED LTL4224 RED	28"	D901
303900	LED ROT	29" / 32" / 33"	D901
056708	SAW FILTER OFW K3958M		F101
056010	SAW FILTER OFW K9656M		F102
056766	SAW FILTER OFW K2962M		F103
056709	SAW FILTER OFW K3953M		F103
055547	FERRIT-CHIP MI0603J680R-00 68R 1A /0603		FB401 FB402 FB403 FB801 FB802 FB803
055571	FERRITE 5*2*8		FB501
054280	FUSE 3.15AT (215)		FS601
054300	FUSE T6.3A		FS602
452382	IC-CHIP S3C1840DA9/SMB1		IC01
451569	IC-CHIP TDA9886T/V3 118(SO24)		IC101 IC102
452510	IC 4053B CMOS 16SOIC		IC201
452595-01	IC MSP3411G B8 V3		IC301
452298	IC TDA2822M		IC302
453082	IC TDA7297		IC303
452878	IC TDA7265 MULTIWAT 11 20.2	SUBWOOFER	IC304
453092	IC-CHIP SDA6000-A23 (M2)(T&R)		IC401
453077	IC-CHIP AT24C32N-10SI-2.7 (T&R)		IC402
453073	IC-CHIP KF25BDT(T&R)		IC403
453097	IC-CHIP MBM29LV160B-90 PFTN (TRAY)		IC404
453098	IC-CHIP HY57V641620HGT-H (T&R)		IC405
452485	IC KA75270 (SAMSUNG)		IC406
453096	IC-CHIP 74LVC04AD SOT108-1 (T&R)PHILIPS		IC407
452437	IC STV9379FA		IC501
452795	IC TDA16846		IC601
451885-01	IC TL431CLP (ON SEMICONDUCTOR)		IC602
451518	IC KA317TU T0220CASE		IC603 IC606
50S310	INSULATOR BUZ90 17*12*.15		IC603 IC604 IC606 IC607 IC501
451849	IC TDB7808		IC605
453100	IC LD1086V T0220CASE		IC607 IC604
453093	IC-CHIP VSP9407B-B11(T&R)		IC801
453072	IC-CHIP FAN1117AD18X(T&R)		IC802
453094	IC-CHIP DDP3315C-D2(T&R)		IC803
452521	IR RECEIVER TSOP 1838		IC901
452300	IC TDA6111Q/N4		IC701 IC702 IC703

PART LIST

PART NO	DESCRIPTION	NOTES	POSITION NUMBERS					
053500	COIL 10UH K AXIAL LAL04		L201	L104	L106	L101	L103	L301
053781	COIL 2.2UH LAL04		L401	L405	L801	L802	L806	L811
053732	COIL 4.7UH LAL04 52MM		L402	L403				
056296	FILTER EMI 470PF		L406	L407	L410			
051706-01	BRIDGE COIL 1MH 20.1		L502					
051707-10	COIL 6MH E/W		L503					
051736-01	COIL 4.2UH LINEARITE V2	28" / 32"	L504					
051810	COIL- LINEARITE 8.3UH	29" / 33"	L504					
051735-02	COIL 150UH CHOKE		L505					
051599-10	LINE FILTER 27MH TOROID		L601	L602				
051811	COIL PFC 40MH DTH30403H57 ELIM TECH		L603					
053739-10	COIL CHOKE 50UH		L604	L501				
053711	COIL 10UH K (TAIYO) LAL03	28" / 33"	L605					
053734	COIL 4.7UH LAL03	29" / 32"	L605					
053743	COIL-CHIP 2.2UH K/0805		L803	L804	L810	L807	L808	L809
133118	R-VAR 10K V(2.5MM) 5*3		P601					
452297-01	IC SFH617 OPTO COUPLER		PH601					
056210	CER.RESONATOR GSB455E		Q01					
056013	CRYSTAL 4 MHZ		Q101	Q102				
056952	CRYSTAL 18.432MHZ +-30PPM		Q201					
056620	CRYSTAL 6MHZ (CL 30PF)		Q401					
056038	CRYSTAL 20.25MHZ 20PPM (106478)		Q801					
056162	CRYSTAL 5MHZ		Q802					
179002	RC-CHIP 0R /1206		R01					
101223	CFR 220R J 1/4W 52MM		R115	R116	R133			
170750	RC-CHIP 75R J 1/10W /0805		R240	R243	R244	R245	R248	R209
170683	RC-CHIP 68R J 1/10W /0805		R242	R210	R226			
171224	RC-CHIP 220R J 1/16W/0603 TAPE		R251	R519	R308	R414	R425	R447
173277	RC-CHIP 27K J 1/16W /0603 TAPE		R304	R306				
129471	RF 4.7R J 0.25W 52MM		R310					
170047	RC-CHIP 4.7R J 1/10W /0805		R311	R312				
172336	RC-CHIP 3.3K J 1/16W /0603		R313	R424	R430	R431	R454	R455
102157	CFR 1.5K J 1/4W /6 52MM		R318	R721	R726	R732		
119470	RMO 4.7R J 1W	SUBWOOFER	R327	R331				
173108	RC-CHIP 10K J 1/16W /0603		R411	R439	R445	R812	R816	R309
173153	RC-CHIP 15K J 1/16W /0603 TAPE		R448					
172224	RC-CHIP 2.2K J 1/16W/0603 TAPE		R459	R813	R633	R141	R255	R260
113271	RM 27K %1 1/4W		R501	R502	R503	R504	R626	
109150	CFR 1.5R J 1/2W /9		R505					
111395	RMO 390R J 1W		R506					
119221	RM 2.2R J 1W		R507	R508				
100473	CFR 47R J 1/4W /6 52MM		R510	R735				
119563	RMO 0.56R J 2W 52MM		R512					
111100	RMO 100R J 2W		R513					
113113	RMF 10K J 1/2W		R514					
121220	RMF 220R J .75W	28" / 32"	R515					
122114	RWF 1K J 1.5W 73MM	29" / 33"	R515					
112683	RMO 6.8R J 1W		R516					
114110	RM 100K %1 1/4W 26MM		R517					
103116	CFR 10K J 1/4W /6 52MM		R527	R624	R631	R649	R652	R656
129395	RMF 3.9R J 0.5W 52MM		R529					
129229	RWF 0.22R J 0.75W		R530	R531	R533			
112335	RMO 3.3K J 1W		R532					
119690	RMF 6.8R J 1W		R536					
119227-01	RMF 2.2R J 1W	28"	R537	R709				
160110	CAP VARISTOR 5006V00001A		R601					
160111	VARISTOR EPCOS S14K385		R601					
114470	RM 470K J 1/2W 52MM		R602					

PART LIST

PART NO	DESCRIPTION	NOTES	POSITION NUMBERS			
154225	PTC 18R/3 PIN		R603			
154216	NTC 5.1R M (S234R)		R604			
100154	CFR 15R J 1/2W 52MM		R607			
115392	RMO 3.9M %1 0.5W		R608			
115104	RMO 1M %1 0.5W		R611			
115470	RM 4.7M J 1/2W 52MM		R616			
110474	RMO 47R J 1/2W 52MM		R618			
119564	RMO 0.56R J 3W		R622			
114105	RM 100K %1 1/2W		R625			
119113	RMF 0.1R J 1/4W (FM 1/4)		R634	R635		
119235	RMO 0.22R J 3W		R636			
171562	RC-CHIP 560R J 1/16W/0603 TAPE		R638	R413	R877	R880
114115	RM 115K %1 1/4W	29" / 32"	R639			
114152	RM 150K F 1/4W 52MM	28" / 33"	R639			
112272	RM 2.7K %1 1/4W 26MM		R643			
171392	RC-CHIP 390R %1 1/16W/0603 TAPE		R644	R646		
102141	CFR 1K J 1/4W /6 26MM		R701	R535		
112131	RM 1.3K %1 1/4W 26MM		R704			
101274	CFR 270R J 1/4W /6 52MM		R707			
119478	RMF 0.47R J 1W	29" / 32" / 33"	R709			
103136	CFR 10K J 1/4W /6 26MM		R710			
111101	RMO 1K J 1W		R723	R729	R734	
055127	CORE FERRIT		RGBKA			
054301	ROLE RT424-012		RL601			
031251	SCART SOCKET 14.1		SK201			
031197	SCART SOKET HR-DM2441S-O		SK202			
401047	TRN BC337-25		T01			
401142	TRN-CHIP BC858B SOT23		T103	T502	T503	T101 T401 T803
401141	TRN-CHIP BC848B SOT23		T402	T405	T802	T807 T809 T810
401331	TRN-CHIP 2SK3065		T501			
401235	TRN 2SC5331		T504			
401231	TRN BDX53C		T505			
400131	TRN FQP12N60		T601			
400339	TRN BF423		T602			
400366	TRN BC546B		T603			
400831	TRN BC548C		T701	T702		
400989	TRN BC558B		T703			
058533-TR4	FBT 28" 20.2	28"	TR501			
058935-TR1	FBT 29" FLAT 20.2	29"	TR501			
058935-TR2	FBT 20.2 29"CF.FOC.TR/003321144	29"	TR501			
058235-TR4	FBT 32"16:9 TR/...20.2	32"	TR501			
058235-TR5	FBT 32"16:9/C CF.FOC.TR/... 20.2	32"	TR501			
058335-TR1	FBT 20.2 33" TERMAL	33"	TR501			
051789	DRIVER TRANSFORMER 20.2		TR502			
059535-EL1	SMPS 28" EL/2094.0082 22.1	28" / 33"	TR601			
059535-TR1	SMPS 28" 22.1	28" / 33"	TR601			
059931-EL1	SMPS 29PF EL/2094.0083 22.1	29"	TR601			
059231-EL1	SMPS 32PF EL/2094.0084 22.1	32"	TR601			
S99136-PH1	TUNER PH SPL ASIMETRIK UV1316 T / ALG-3		TU101			
G99136-PH2	TUNER PH ASM.PLL UV1316/AIG-3 SV22		TU102			
031866	CONN.HOUSING X2006 GREY		X202			
031313	CONN.30P 3MM MOLEX-52872-3011		X203			
031312	CONN.20P 3MM MOLEX-52872-2011		X204			
031854	CONN.HOUSING X2003 GREY		X301	X940		
031858	CONN.HOUSING X2004 GREY		X302			
031090	PIN HEADER 2*4		X401	X404		
031872	CONN.HOUSING X2007 BLACK		X405			

PART LIST

PART NO	DESCRIPTION	NOTES	POSITION NUMBERS
031291	PIN HEADER 2P		X407 X408
031794	CONN.MALE HOR. 4.PIN PLUG		X503
031675	CON.HOUSING 2P MALE		X601 X501
031672	CON.HOUSING 2P MALE RED		X602
031823	CON.HOUSING X2.5TMK 2204 BLACK	28" / 32"	X702
031821	CON.HOUSING X2.5TMK 2204 GRAY	29" / 33"	X702
031541	CRT SOCKET 29" DOUBLE FOCUS	29" / 32"	X703
031530-02	INCHANG/CRT SOCKET ISHM23S-W	28" / 33"	X703
031021	PIN HEADETR 2.54MM 3.PC.MOLEX 14.1		X783 X784
031280	CINCH AUDIO 2P		X785
031320	CONN.20P 3MM MOLEX 53.615-2011		X801
031299	CONN.HOUS.10P 2317-10S JST4B-XH-A BEYAZ		X803 X701
031330	CONN.30P 3MM MOLEX 53.615-3011		X805
031870	CONN.HOUSING X2007 GREY		X807
031165	KONN. CINCH YELLOW HOR.14.1	29" / 32"	X921
031162	KONN. CINCH RCA PJ803-4 YELLOW VER.14.1	28" / 33"	X921
031164	KONN. CINCH RED HOR.14.1	29" / 32"	X922
031161	KONN. CINCH RCA PJ803-3 RED VER.14.1	28" / 33"	X922
031163	KONN. CINCH WHITE HOR.14.1	29" / 32"	X923
031160	KONN. CINCH RCA PJ803-2 WHITE VER.14.1	28" / 33"	X923
031784	KONN.S-VHS B10B MONAKOR	29" / 32"	X924
031788	KONN.S-VHS DIN-406D VER.14.1	28" / 33"	X924
031423	HEADPHONE JACK YKB21-5103		X941
303765	DIOED-CHIP BZT55C5V6-GS08 VISHAY		ZD401 ZD402 ZD403 ZD404 ZD405 ZD406
302298	DIODE Z. ZPD5.1V 26MM		ZD501
300193	DIODE Z. BZX55C9V1-GPS(VISHAY)		ZD502 ZD701
302318	DIODE Z. BZX55C33		ZD503
303814	DIODE Z.MTZJ39B		ZD504 ZD505
303771	DIODE Z. UZT33V		ZD601
5YZ205-31	BACK COVER (GREY FR) 33BZTL5/6 3S/AU/SWO	33" 4:3	
6X1205-26	BACK COVER (LG GREY)32T20 BEKO 3SC+AUB 2	32" 16:9	
7T1205-26	BACK COVER (SILVER) 28T08 3-SC 22.1	28" 4:3	
7PZ205-26	BACK COVER LGRI 29FLAT BEKO 22.1 3S+AU+S	29"	
7XB273	BACK COVER R/C FLAT GREY	33"	
BB7273	BACK COVER R/C FLAT LG-GREY	29" / 32"	
T60273	BACK COVER R/C FLAT SILVER	28"	
7UZ216-20	CHASSIS BRACKET 20.2		
7XB276	COVER BATTERY BOX R/C GREY M.	33"	
BB7276	COVER BATTERY BOX R/C LG-GREY	29" / 32"	
T60276	COVER BATTERY BOX R/C SILVER	28"	
DJ4251-40	FRONT COVER GREY PAINTED 33TL5		
7W7251-23	FRONT COVER SILV.PAINTED 28BCT08 HP+SV		
U64251	FRONT COVER SILVER PAINTED 29B8T12		
6X8251	FRONT COVER SILVER PAINTED 32BCT20		
DJ2261	FRONT PANNEL SILV.100HZ/VDL/D.FL 29T33		
7UB222-01	FUNCTION PLK.28T08 SVHS+HP		
833293	HOLDER BACK COVER		
7RZ292-03	HOLDER HP.KON.S-VHS 28B4T0533" GREY		
7PZ277	HOLDER MAIN CABLE 29T12(FASON)	29" / 32"	
7XZ277	HOLDER MAIN CABLE MITSUBISHI (FASON)	28" / 33"	
6X1258	KNOB MAIN SW. SILVER PAINTED T12/T19/T20		
5YY258	KNOB MAIN SW.GREY S.LI 33P1TL5		
U47258	KNOB MAIN SW.SILV.PAINTED 29T25/29T33		
7W7258	KNOB MAIN SW.SILVER 28T08		
7PZ273	KNOB PROG.CONT.PANEL 29" T12(FASON)		
7PA282	KNOB PROGRAM CONT.PANEL 29T17		
5YY282	KNOB PROG-VOLUME 33TL5		

PART LIST

PART NO	DESCRIPTION	NOTES	POSITION NUMBERS
7XZ276	LOCK CU.FUME MAS. MTSB CABINETS(FASON)		
5YY320	NAME PLATE ARCELIK 33P1TL5 13*60		
7PZ279	PANEL 29T12(FASON)		
7PB279	PANEL 29T25(FASON)		
5YY279	PANEL 33P1TL5(FASON)		
DJ4259	PANEL GRI S.LI 33TL5 FX+PIP+100HZ		
6X8222	PLATE FUNCTION FSIL.PRG-VOI.T19/T12/T23		
T50187F	RC FLAT B-TYPE BEKO SIL/LGRI 22.1		
DJ3187F	RC FLAT B-TYPE BEKO SILVER 22.1		
7UB806	STROPOR BOT.LEFT-RIGHT 28T08 MTSB		
7PZ806	STROPOR BOTTOM 29B4T12 FLAT		
5YZ806	STROPOR BOTTOM 33" PLASTIK 11.1		
7PZ805	STROPOR TOP 29B4T12 FLAT		
5YZ805	STROPOR TOP 33" PLASTIK 11.1		
7UB805	STROPOR TOP LEFT-RIGHT 28T08 MTSB		
600303	TERMINAL BATT.BOX(+ -) R/C		
DJ2252	TOP COVER R/C A-FLAT GREY		
T50252	TOP COVER R/C B-FLAT SMRT-C. M.GREY		
DJ3261	VR DOOR PAINTED SILV.28T08 100HZ/V DOL		
7W7260	VR DOOR SAT.REC.SILVER MB.28T08		
7XB277	WINDOW FILTER R/C FLAT		
DJ7110	BZ CHASSIS 28 PS/NVDX/3S/HP/SVH/AUB/PIP	28"	
DJ4110	BZ CHASSIS 33 PS/VDNX/3S/HP/SV/AU/SW/PIP	33"	
DJ1110	BZ CHASSIS PS/NVDTX/3S/HP/SVHS/AUB/SWOO	32"	
DJ6110	BZ CHASSIS PS/NVDTX/3S/HP/SVHS/AUB/SWOO	29"	
DJ1165	BZ CRT BOARD	32"	
DJ4165	BZ CRT BOARD	33"	
ZA1165	BZ CRT BOARD	28"	
ZA9165	BZ CRT BOARD	29"	
DJ5160	BZ-MN FEAT.BOX 22.1 29 3SC FLAT 4:3	29" 4:3	
DJ1160	BZ-MN FEAT.BOX 22.1 32" 3SC FLAT 16:9	32" 16:9	
DJ7160	BZ-MN FEATURE BOX 22.1 28 3SC 4:3	28" 4:3	
DJ4160	BZ-MN FEATURE BOX 33 22.1 3SC 4:3	33" 4:3	
DJ1172	CU ASSY 29T12 22.1		
Y01172	CU ASSY 33"TL5 14.2		
S96130	CU+SVHS ASSY 21T04/28T08/25T15 14.2		
7SZ185	H.PHONE MOD. 14.1		
DJ2160	IR/LED ASSY 29T12 22.1		
7PZ191	PCB CU 29T12	29" / 32"	
7VA191	PCB CU 14.1	33"	
7UB191	PCB CU 21T04/28T08/25T15 14.1	28"	
056328-PH3	CPT PH A66EAF071X44 100HZ	28" 4:3	
056432-PS1	CPT PS W76EKW10X71 (100HZ) P.FLAT	32" 16:9	
056329-SB2	CPT SEB A68QCP891X232 (100HZ)	29" 4:3	
056333-VC7	CPT VC A80AEJ10X522 (100HZ) ITALY	33" 4:3	
533167-AS	DEGAUSSING COIL 33"	33" 4:3	
628167-AS	DEGAUSSING COIL ASSY 28" BAND	28" 4:3	
629167-AS	DEGAUSSING COIL ASSY 29" BAND	29" 4:3	
532168-AS	DEGAUSSING COIL ASSY 32" BAND(9R PTC)	32" 16:9	
5YX107-AS	SPEAKER 8R .../15W(M) 207X64		
7UB107-AS	SPEAKER 8R 10W/15W(M) 102X102		
6X1107-AS	SPK.8R .../15W(M) 177.5X45		
7UB109-AS	SUBWOOFER SPEAKER 4R 20W(N)/...		
7XZ109-AS	SUBWOOFER SPEAKER 4R 20W(N)/...		
7VA109-AS	SUBWOOFER SPEAKER 4R 40W(N)/...134X71.5		
7UB108-AS	TWEETER SPEAKER 10R 5W(N)/10W(M) 53X28		
7VA108-AS	TWEETER SPEAKER 8R 12W(N)/15W(M) 52X74		

FEATUREBOX MODUL

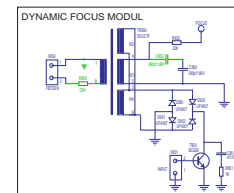
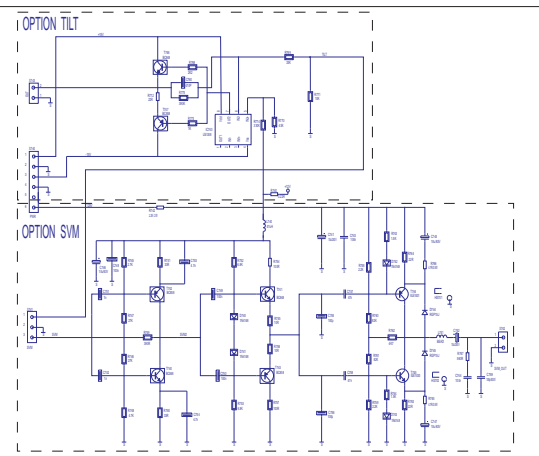
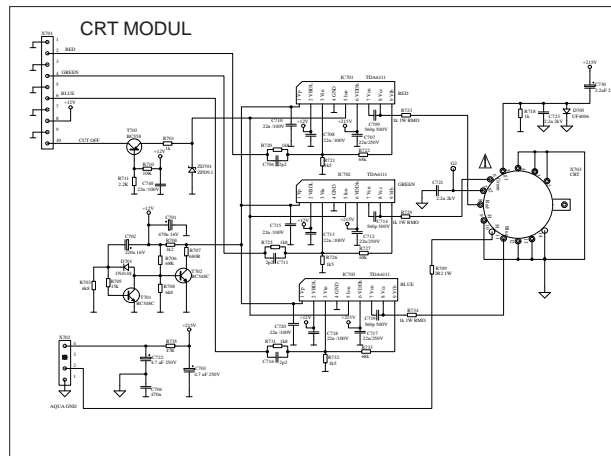
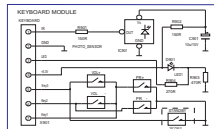
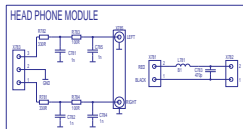
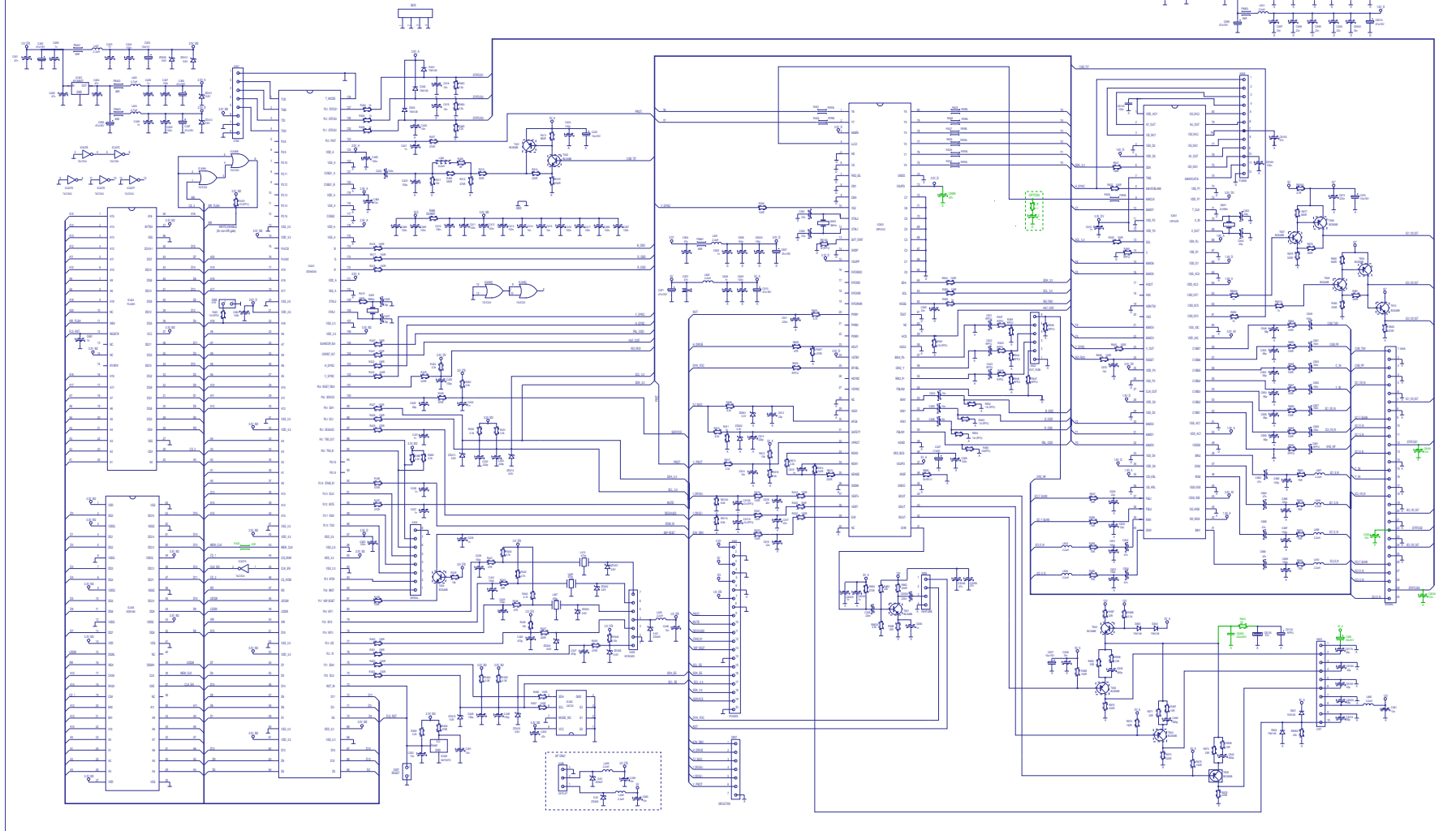

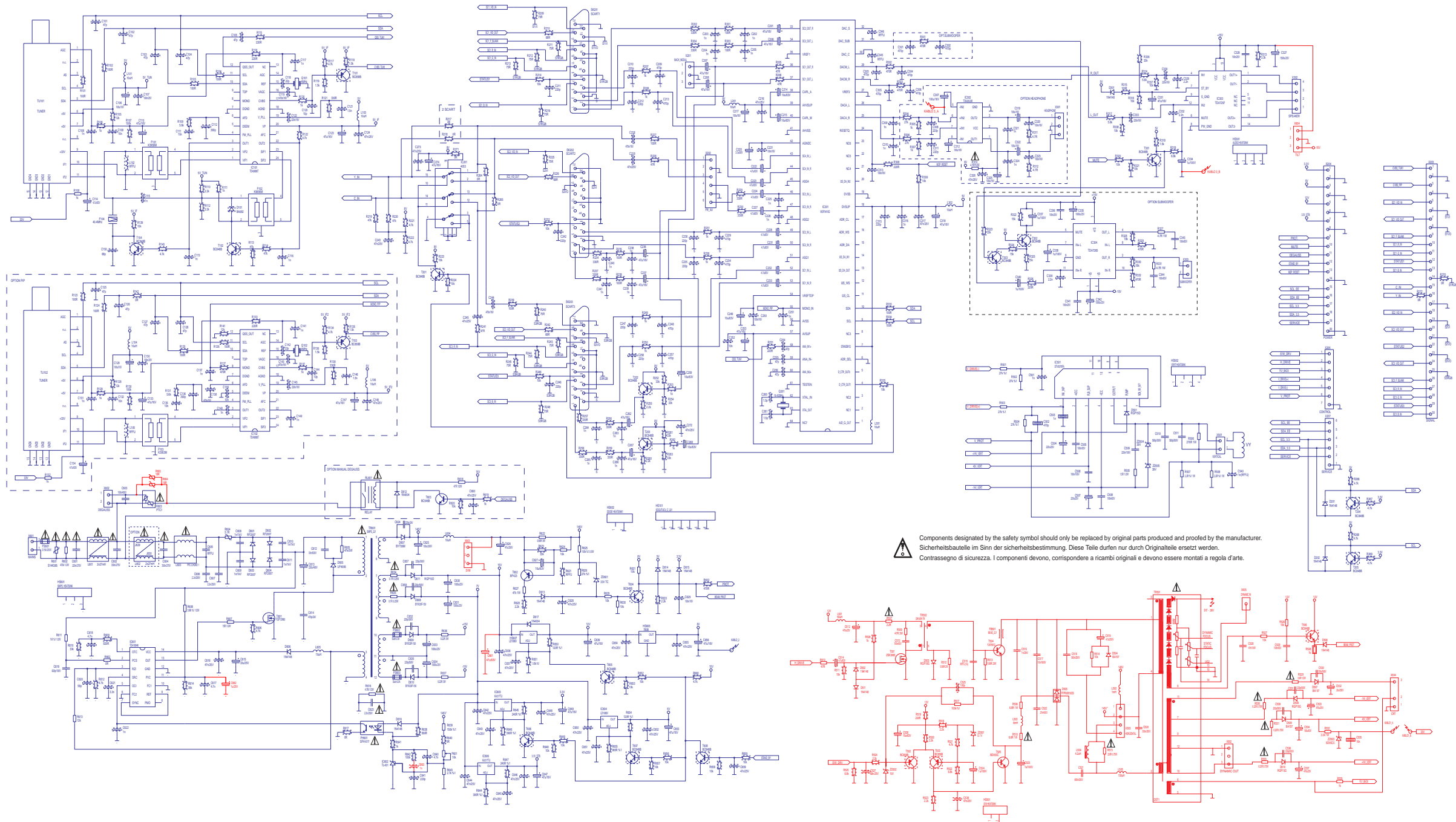

⚠ Components designated by the safety symbol should only be replaced by original parts produced and proofed by the manufacturer.
 Sicherheitsbauteile im Smn der sicherheitsbestimmung. Diese Teile dürfen nur durch Originalteile ersetzt werden.
 Contrassegno di sicurezza. I componenti devono, corrispondere a ricambi originali e devono essere montati a regola d'arte.