

**Goodmans**

# Service Manual

Stereo Colour Television

**CHASSIS : CP-775  
PAL-I SYSTEM  
(NTSC PLAY BACK)**

**STEREO, TELETEXT,**

**MODEL : 255NS/255NS(B)/  
285NS/285NS(B)**

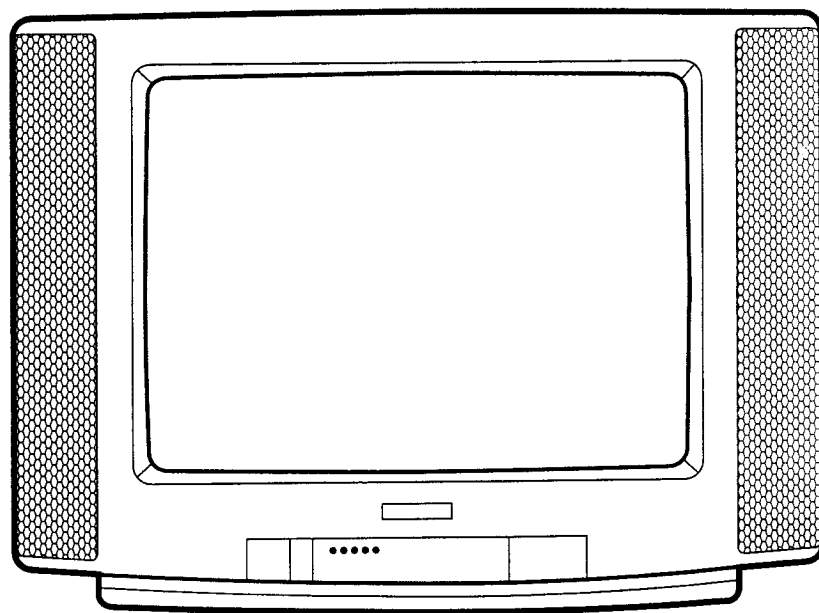

**COMET GROUP PLC**

## ■ Specifications

CRT	25" : A59EAK071X11 (PHILIPS) 28" : A66EAK071X11 (PHILIPS)
System	TF : PAL - B/G for West Europe, NTSC-3.58 / 4.43 (Play back) TA : PAL - B/G, SECAM-L/L' for France, NTSC-3.58 / 4.43 (Play back) TU : PAL- I for U.K, NTSC-3.58 / 4.43 (Play back) TK : PAL/SECAM - B/G, D/K, NTSC-3.58/4.43(play back) for East Europe & CIS
Main Voltage	230V AC, 50Hz
Power Consumption	Stand-by mode : 10 Watts Normal operating mode : 25" = 75 Watts 28" = 75 Watts
Sound output	5 + 5 Watts, 10 % THD at RF 60 % mod. (1 kHz)
Speaker	12W 4 ohm x 2 EA
Antenna Impedance	75 ohm unbalanced input
Tuning system	VS( voltage synthesis ) tuning
Tuner	3303KHC (TF, TA, TK, TI Model) BAND I : CH2 - CH4 BAND III : CH5 - CH12 CABLE BAND : S1' - S3' , S1 - S20 HYPER BAND : S21 - S41 BAND IV, V : CH21 - CH69 DT2-IV17D (TU Model ) BAND IV, V : CH21 - CH69
Number of program	70 programs
Aux. Terminal	21 pin EURO-SCART jack ( AV input, TV output, RGB input ) 21 pin EURO-SCART jack ( AV input, S-VHS input ) RCA type AV input jack Headphone jack (3.5 mm $\phi$ )
Remote controller	R-28B03 or R-35D05 with 2 "AA" type batteries
Teletext	8 pages memory TOP & FLOF - West option :English, German/Dutch/Flemish, French, Italian, Spanish/Portuguese, Swedish/Finnish/Danish, Czech/Slovak - East option : Polish, Czech/Slovak, Rumanian, Hungarian, Servo-croat, German/Dutch/Flemish, French, Italian - Turkish option : Turkish, English, German/Dutch/Flemish, French, Italian, Spanish/Portuguese, Swedish/Finnish/Danish - Cyrillic option: Russian, Lettish/Lithuanian, Estonian, Ukranian, Czech/Slovak, Servo-croat, English
OSD language	-East,West,Turkish Version : English,French,German,Italian,Spanish -Cyrillic Version : Russian, English, German

**\* 21 PIN EURO-SCART**

PIN	Signal Designation	Matching Value
1	Audio Out(linked with 3)	0.5Vrms,Imp<1 k $\Omega$ (RF 60% MOD)
2	Audio In(linked with 6)	0.5Vrms,Imp>10 k $\Omega$
3	Audio Out(linked with 1)	0.5Vrms,Imp<1 k $\Omega$ (RF 60% MOD)
4	Audio Earth	
5	Blue Earth	
6	Audio in (linked with 2)	0.5Vrms,Imp>10 k $\Omega$
7	Blue in	0.7Vpp $\pm$ 3 dB,Imp75 $\Omega$
8	Slow(Function) Switching	TV:0-2V,PERI:9.5-12V,Imp>10 k $\Omega$
9	Green Earth	
10	NC	
11	Green In	0.7Vpp $\pm$ 3 dB,Imp75 $\Omega$
12	NC	
13	Red Earth	
14	NC	
15	Red In, C In	0.7Vpp $\pm$ 3 dB,Imp75 $\Omega$
16	Rapid(Blanking) switching	Logic 0:0-0.4V,Logic 1:1-3V,Imp 75 $\Omega$
17	Video Earth	
18	Rapid Blanking Earth	
19	Video Out	1Vpp $\pm$ 3 dB,Imp75 $\Omega$
20	Video In, Y In	1Vpp $\pm$ 3 dB,Imp75 $\Omega$
21	Common Earth	

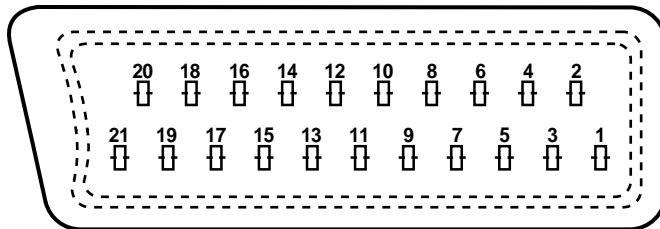

## ■ Safety Instruction

**WARNING:** Only competent service personnel may carry out work involving the testing or repair of this equipment.

### ■ X-RAY RADIATION PRECAUTION

1. Excessive high voltage can produce potentially hazardous X-RAY RADIATION. To avoid such hazards, the high voltage must not exceed the specified limit. The nominal value of the high voltage of this receiver is 26kV at max beam current. The high voltage must not, under any circumstances, exceed 29.5kV (25"), 30kV (28"). Each time a receiver requires servicing, the high voltage should be checked. It is important to use an accurate and reliable high voltage meter.
2. The only source of X-RAY Radiation in this TV receiver is the picture tube. For continued X-RAY RADIATION protection, the replacement tube must be exactly the same type tube as specified in the parts list.

### ■ SAFETY PRECAUTION

1. Potentials of high voltage are present when this receiver is operating. Operation of the receiver outside the cabinet or with the back board removed involves a shock hazard from the receiver.
  - 1) Servicing should not be attempted by anyone who is not thoroughly familiar with the precautions necessary when working on high-voltage equipment.
  - 2) Discharge the high potential of the picture tube before handling the tube. The picture tube is highly evacuated and if broken, glass fragments will be violently expelled.
2. If any Fuse in this TV receiver is blown, replace it with the FUSE specified in the Replacement Parts List.
3. When replacing a high wattage resistor (oxide metal film resistor) in circuit board, keep the resistor 10mm away from circuit board.
4. Keep wires away from high voltage or high temperature components.
5. This receiver must operate under AC230 volts, 50Hz. NEVER connect to DC supply or any other power or frequency.

### ■ PRODUCT SAFETY NOTICE

Many electrical and mechanical parts in this have special safety-related characteristics. These characteristics are often passed unnoticed by a visual inspection and the X-RAY RADIATION protection afforded by them cannot necessarily be obtained by using replacement components rated for higher voltage, wattage, etc. Replacement parts which have these special safety characteristics are identified in this manual and its supplements, electrical components having such features are

identified by designated symbol on the parts list. Before replacing any of these components, read the parts list in this manual carefully. The use of substitute replacement parts which do not have the same safety characteristics as specified in the parts list may create X-RAY Radiation.

# Alignment Instructions

## 1. AFT

### 1.1 Standard B/G,D/K,I and L

- 1) Set a Signal Generator with
  - RF FREQUENCY = 38.9 MHz,
  - RF OUTPUT LEVEL =  $80 \pm 5$  dBuV
  - System = PAL / SECAM - B/G, D/K, I
- 2) Connect the Signal Generator RF Output to P101 (Tuner IF Output).  
There must be no signal input to the tuner.
- 3) Press the "AFT" KEY and wait until the TV screen display "AFT OK".

### 1.2 Standard SECAM-L' (France VHF-Low)

\* Above mentioned "1.1" adjustment has to be done in advance.

- 1) Set a Signal Generator with
  - RF FREQUENCY = 34.5 MHz,
  - RF OUTPUT LEVEL =  $80 \pm 5$  dBuV
  - System = SECAM - L'
- 2) Connect the Signal Generator RF Output to P101 (Tuner IF Output).  
There must be no signal input to the tuner.
- 3) Press the "L' AFT" KEY and wait until the TV screen display "L AFT OK".

## 2. AGC

- 1) Set a Pattern Generator with RF LEVEL  $63 \pm 2$  dBuV .
- 2) Connect a OSCILLOSCOPE PROBE to P101 (TUNER AGC INPUT).
- 3) Adjust AGC UP/DOWN KEY the voltage drop 1V dc over below its maximum voltage.

\* Alternative Method

- 1) Set a Pattern Generator with
  - RF LEVEL  $80 \pm 5$  dBuV
  - PAL CROSSHATCH  
( without SOUND CARRIER )
- 2) Connect a OSCILLOSCOPE  
( Bandwidth  $\geq 100$ MHz ) PROBE  
to P101 (TUNER IF OUTPUT).
- 3) Use AGC UP/DOWN KEY to obtain  
an envelop amplitude 200 + 50 mVp-p.

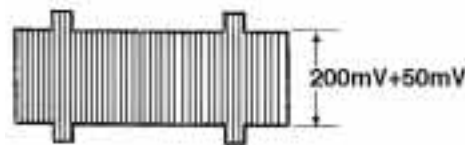

## 3. SCREEN

- 1) Apply a COLOR BAR pattern signal.
- 2) Set the CONTRAST, BRIGHTNESS to MAX, COLOR to MIN.
- 3) Set the R,G,B LEVEL to CENTER (31/63) with R,G,B UP/DOWN KEY.
- 4) Connect a OSCILLOSCOPE PROBE to P906 ( CRT CATHOD R, G, B ).
- 5) Adjust the SCREEN VOLUME on FBT such that the highest black level voltage  $140 \pm 5$ Vdc.

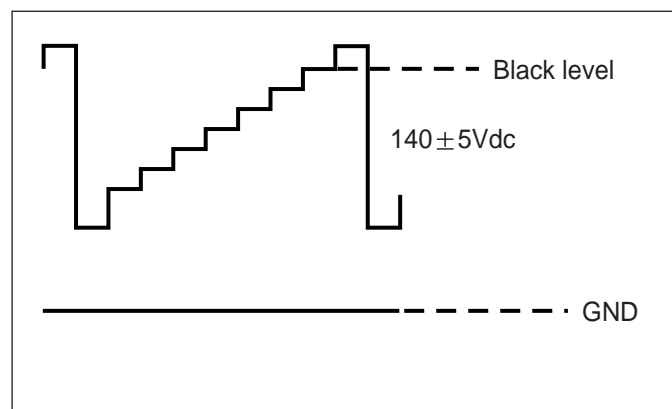

---

#### 4. WHITE BALANCE

- 1) Set the TV to NOR I mode.
- 2) Set the R,G,B LEVEL to CENTER with R,G,B UP/DOWN KEY .
- 3) Adjust the R,G,B UP/DOWN KEY of the other color which did not appear on the screen to obtain WHITE.

#### 5. FOCUS

- 1) Apply a RETMA PATTERN signal.
- 2) Adjust the FOCUS VOLUME on FBT to obtain optimal resolution.

#### 6. GEOMETRY

##### 6.1 VERTICAL CENTER

- 1) Set the TV to NOR I mode.
- 2) Pressing the V-SIZE UP/DOWN KEY, the lower half of the screen is blanked.
- 3) Adjust the border line of blanked picture coincident with the mechanical center marks of the CRT using the V-SIZE UP/DOWN KEY.

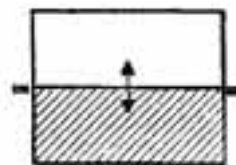

##### 6.2 VERTICAL SIZE

\* The VERTICAL CENTER adjustment has to be done in advance.

- 1) Apply a RETMA PATTERN signal.
- 2) Set the TV to NOR I mode.
- 3) Adjust the upper part of the picture with the V-SIZE UP/DOWN keys.

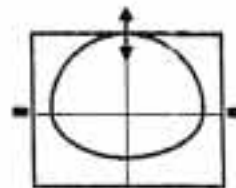

##### 6.3 VERTICAL SLOPE

\* The VERTICAL SIZE adjustment has to be done in advance.

- 1) Apply a RETMA PATTERN signal.
- 2) Adjust the lower part of the picture with the V-SLOPE UP/DOWN keys.

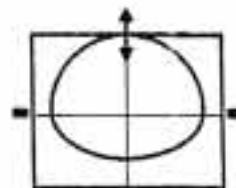

##### 6.4 VERTICAL S-CORRECTION

- 1) Apply a CROSSHATCH PATTERN signal.
- 2) Adjust the S-COR UP/DOWN KEY to obtain the same distance between horizontal lines.

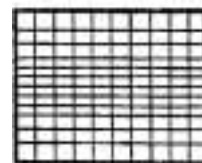

##### 6.5 HORIZONTAL CENTER

- 1) Apply a RETMA PATTERN signal.
- 2) Adjust picture centering with CENTER LEFT/RIGHT keys.

---

## 7. EW

### 7.1 WIDTH

- 1) Apply a RETMA PATTERN signal.
- 2) Pressing the EW KEY, the WIDTH OSD appear in the screen.
- 3) Adjust the over to make a perfect circle with VOL-UP/DOWN KEY.

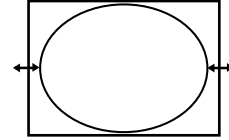

### 7.2 PARA

- 1) Apply a CROSSHATCH PATTERN signal.
- 2) Pressing the EW KEY, the PARA OSD appear in the screen.
- 3) Adjust the vertical line to straight with VOL-UP/DOWN KEY.

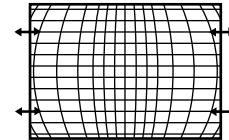

### 7.3 CORNER

- 1) Apply a CROSSHATCH PATTERN signal.
- 2) Pressing the EW KEY, the CORNER OSD appear in the screen.
- 3) Adjust the vertical line to straight with VOL-UP/DOWN KEY.

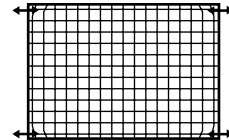

### 7.4 TRAPI

- 1) Apply a CROSSHATCH PATTERN signal.
- 2) Pressing the EW KEY, the TRAPI OSD appear in the screen.
- 3) Adjust the vertical line to straight with VOL-UP/DOWN KEY.

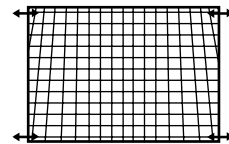

- If EEPROM (I702) has been changed ;
- Option data has to be changed and
  - all alignment function has to be readjusted .

\* The initial state of adjustment are as follows;

	28TAF	28TUF	28TFF
TUNER	3303KHC	DT21V17D	3303KHC
LANGAGE	French	English	English
W/B	RGB = 32	32	32
AGC	11	9	10
V-CENTER	30	37	30
V-SIZE	52	54	52
V-SLOPE	27	28	27
S-COR	15	15	15
H-CENTER	43	42	42
WIDTH	63	63	62
PARA	36	38	37
CORNER	30	28	30
TRAPI	29	28	29

\* Service Remocon

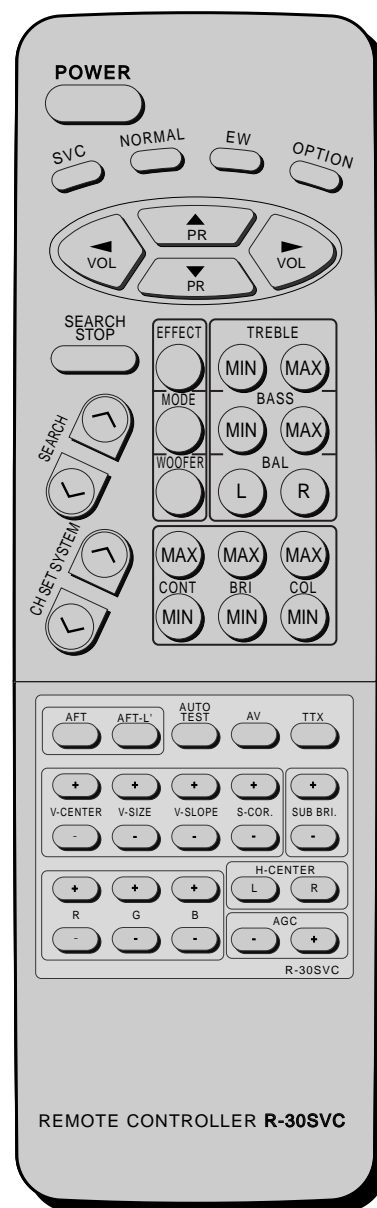



# SIF ADJUSTMENT

## 1. APPARATUS CONNECTION & PRESETTING

### \* CONNECTION

- 1) Connect H-out of LSW-480 to X-axis of the oscilloscope and V-out of LSW-480 to Y-axis of the oscilloscope.
- 2) Connect the sweep signal output to TP1.
- 3) Set ATTENUATOR of LSW-480 to 20dB.
- 4) Supply 12V D.C. voltage(B+) to TP3.
- 5) Supply 3V D.C. voltage(B+) to TP4.
- 6) Connect the test point of LSW-480 to TP2.
- 7) Adjust L109(AFT COIL) so that the P marker point is located on the reference level.

### \* PRESET

- 1) Oscilloscope Scaling
  - a) Put the scale of X and Y of the oscilloscope to D.C. level
  - b) Set the horizontal time display to X-Y.
  - c) Put the horizontal axis (x) to 1V / div. and the vertical axis (Y) to 2V / div.
- 2) LSW-480 MARKER FREQ. SETTING

fp(n+1)	fs	fc	fp-2	fp	fs(n-1)
31.9	33.4	34.47	36.9	38.9	40.4

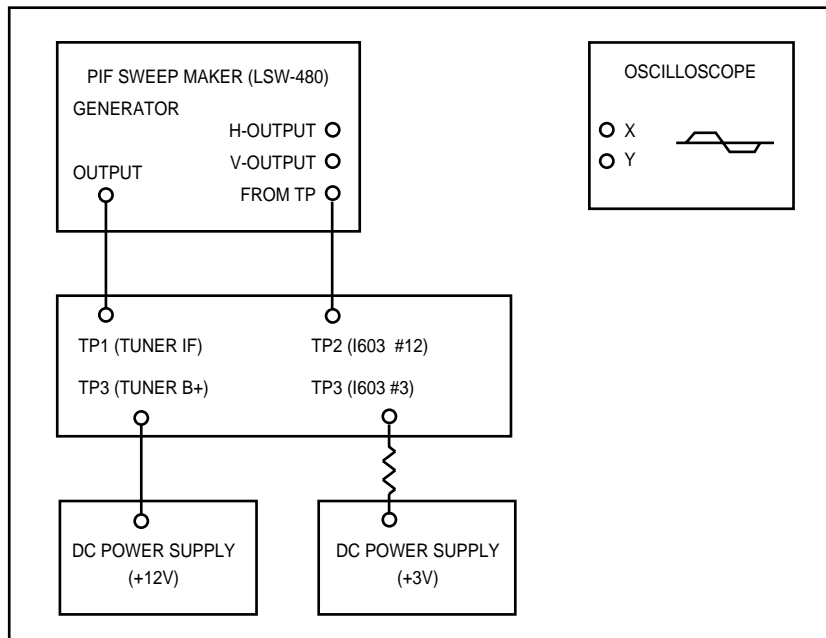

- Connection For SIF Adjustment -

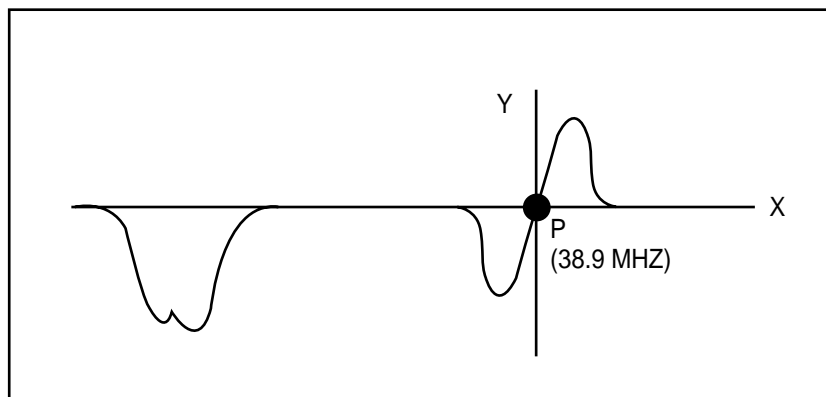

# ■ IC Description

---

## DW5255S\*(Micro-controller & West/East Teletext Decoder)

### (1) General Description

The TDA5255 contains a slicer for VPS and TTX, an accelerating acquisition hardware module, a display generator for "LEVEL 1" TTX data and a 8 bit u-controller running at 333 nsec cycle time.

The controller with dedicated hardware guarantees flexibility, does most of the internal processing of TTX acquisition, transfers data to/from the external memory interface and receives/transmits data via I2C and UART user interfaces.

The Slicer combined with dedicated hardware stores TTX data in a VBI 1Kbyte buffer.

The u-controller firmware does the total acquisition task ( hamming- and parity -checks, page search and evaluation of header control bits) once per field.

### (2) Feature

#### • Acquisition:

- feature selection via special function register
- simultaneous reception of TTX and VPS
- fixed framing code for VPS and TTX
- programmable framing code window for TTX
- Acquisition during VBI
- direct access to VBI RAM buffer
- Acquisition of packets x/26, x/27, 8/30 (firmware)
- assistance of all relevant checks (firmware)
- 1-bit framing-code error tolerance (switchable)

#### • Display:

- features selectable via special function register
- 50/60 Hz display
- level 1 serial attribute display pages
- blanking and contrast reduction output
- 8 direct addressable display pages
- 12 x 10 character matrix
- 96 character ROM (standard G0 character set)
- 143 national option characters for 11 languages
- 288 characters for X/26 display
- 64 block mosaic graphic characters
- 32 free addressable characters for OSD in expanded character ROM + 32 inside OSD box
- double height (TOP/BOTTOM)
- conceal/reveal
- transparent foreground/background -inside/outside of a box
- cursor (colour changes from foreground to background colour)
- flash (flash rate 1s)
- programmable horizontal und vertical sync delay
- hardware assisted fast display page erase
- full screen background colour in outer screen

#### • Synchronization:

display synchronization to sandcastle or Horizontal Sync (HS) and Vertical Sync (VS) with startstop-oscillator or display synchronization to sandcastle or Horizontal Sync and Vertical Sync with external clock  
independent clock systems for acquisition, display and controller

#### • Controller:

- 8 bit configuration
- 18 MHz internal clock
- 0.33 us instruction cycle
- eight 16-bit data pointer registers (DPTR)

- two 16-bit timers
- watchdog timer
- serial interface (UART)
- 256 bytes on-chip RAM
- 1 Kbyte on-chip extended RAM (access via MOVX)
- 8 Kbyte on-chip ACQ-buffer-RAM (access via MOVX)
- 6 channel 8-bit pulse width modulation unit
- 2 channel 14-bit pulse width modulation unit
- 4 multiplexed ADC inputs with 8-bit resolution
- one 8-bit I/O port with open drain output and optional I2C emulation
- two 8-bit multifunctional I/O ports
- one 4-bit port working as digital or analog inputs
- one 2-bit I/O port with optional address latch enable function
- P-SDIP 52 package
- 5 V supply voltage

### (3) Block Diagram

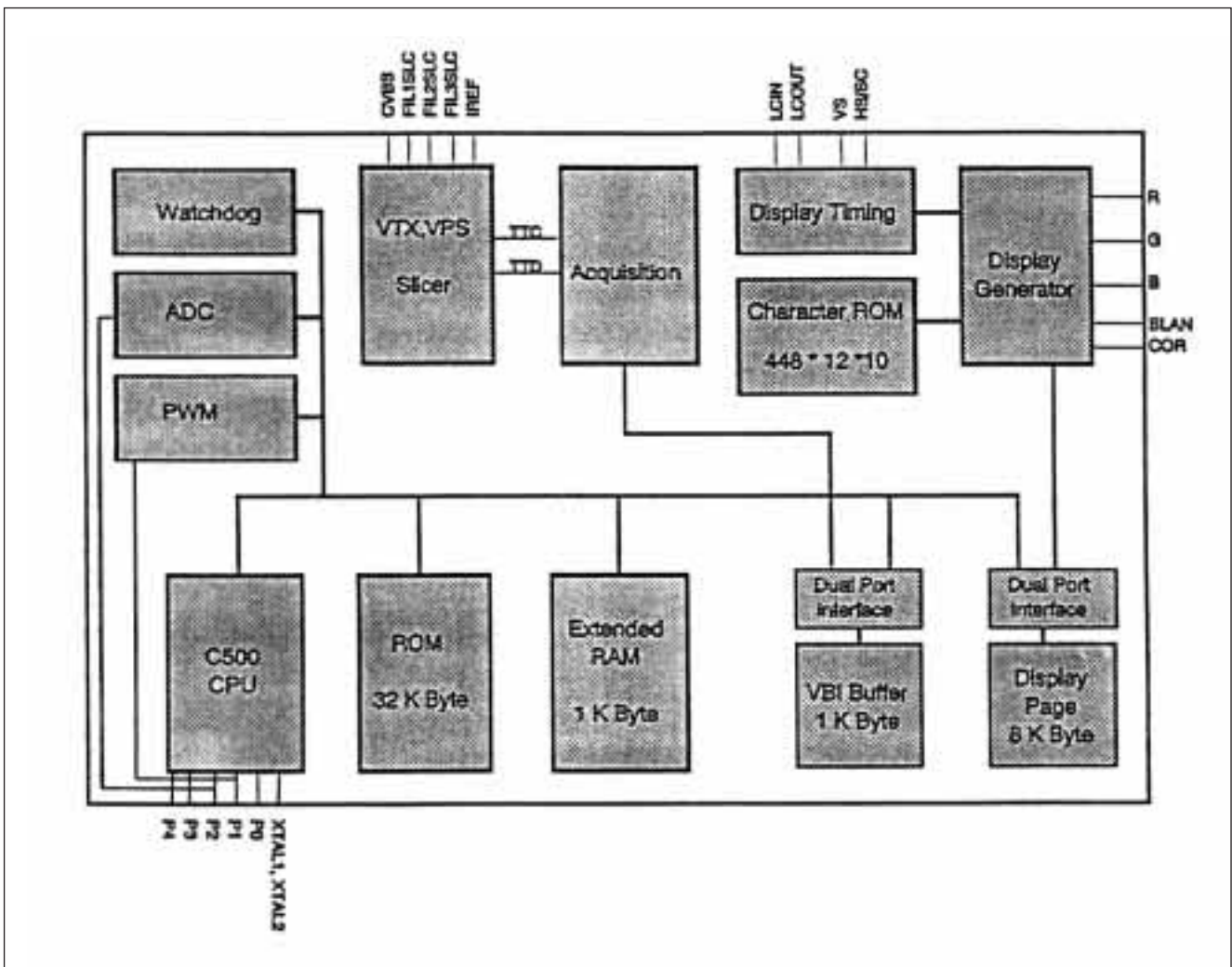

Pin	Name	Symbol	Description
1	P3.1	SYS	SECAM-L' OUT for switching SAW filter L9461 - SECAM-L' : H - SECAM- L : L
2	P0.7/Open Drain	BUSSTOP	I2C BUS STOP IN for Computer controlled alignment in Factory ( Active Low )
3	P0.6/Open Drain	SDA	Serial data IN/OUT for I2C
4	P0.5/Open Drain	SCL	Serial clock IN/OUT for I2C
5	P0.4/Open Drain	OPTION	#5 #6 Teletext
6	P0.3/Open Drain	OPTION	H H West Teletext L H East Teletext H L Turkish Teletext
7	P0.2/Open Drain	OPTION	#7 #8 #17 Tuning / Sound System
8	P0.1/Open Drain	OPTION	L H H B/G (2-G, NICAM) H H H B/G, D/K (2-C, NICAM) L L H I/I (NICAM) H L H I (UHF only, NICAM) H H L L/L' → B/G (2-C, NICAM) L H L B/G → L/L' (2-C, NICAM)
9	P0.0/Open Drain	LED	LED drive OUT - Stand-by mode : H - Operating mode : L ( IR reception : pulse )
10	VSS	VSS	ground
11	VCC	VCC	Power Supply
12	XTAL1	OSCIN	Input to inverting osc. Amplifier
13	XTAL2	OSCOOUT	Output of inverting osc. Amplifier
14	P4.0/ALE		Not Used
15	RESET	RST	RESET IN (ACTIVE LOW)
16	P1.7/14BIT PWM	VT	TUNING VOLTAGE OUT
17	P1.6/14BIT PWM	OPTION	TUNING SYSTEM
18	P1.5/14BIT PWM	F/SW	F/SW IDENT IN for stopping OSD display in RGB mode - H : TV /AV mode - L : RGB mode
19	P1.4/14BIT PWM	OPTION	ATS OPTION H : ON L : OFF
20	P1.3/14BIT PWM	MUTE	AUDIO MUTE OUT
21	P1.2/14BIT PWM	GND	GND
22	P1.1/8BIT PWM		Not Used
23	P1.0/8BIT PWM		Not Used

Pin	Name	Symbol	Description
24	VSSA	VSSA	Analog GND for Slicer
25	FIL3	FIL3	PLL Loop Filter I/O for Phase Shifting
26	FIL2	FIL2	PLL Loop Filter I/O for TTX Slicing
27	FIL1	FIL1	PLL Loop Filter I/O for VPS Slicing
28	VCCA	VCCA	Analog Supply for Slicer
29	IREF	IREF	Reference Current for Slicer PLLs
30	CVBS	CVBS	CVBS IN
31	P2.3/8 bit ADC		Not Used
32	P2.2/8 bit ADC	AGC	IF AGC INPUT for Auto Tuning System
33	P2.1/8 bit ADC	KS	Local KEY SCAN IN
34	P2.0/8 bit ADC	S/SW	S/SW IDENT IN for Automatic switching between TV/AV mode - H : AV / RGB mode - L : TV mode
35	VSS VSS-OSD	VSS	Ground
36	P3.3/INT1	IR	REMOTE IR IN
37	VDD VCC-OSD	VDD	Power Supply
38	LCIN OSCIN-OSD	LCIN	CLOCK IN for OSD
39	LCOUT	LCOUT	CLOCK OUT for OSD
40	P3.7/TXT I/O	BL	BAND VHF-L OUT ( Active High )
41	P3.6/RXD	BH	BAND VHF-H OUT ( Active High )
42	P3.5/T1	BU	BAND UHF OUT ( Active High )
43	P3.4/T0	POWER	POWER CONTROL OUT
44	P3.2/INT0		Not Used
45	HS/SC	HSYNC	HOR. SYNC. IN (Active High)
46	P4.7/VS	VSYNC	VERT. SYNC. IN (Active High)
47	R	R	RED OUT
48	G	G	GREEN OUT
49	B	B	BLUE OUT
50	BLANK	BL	BLANK OUT
51	COR	COR	Not Used (CONTRAST REDUCTION OUT)
52	P3.0 T1C2/PWM1	EVEN/ODD	EVEN/ODD OUT for non-interlacing in TTX mode

## CAT24C08P (E<sup>2</sup> PROM)

### (1) Typical Features

- IC Bus compatible
- Low power CMOS Technology
- 16 Byte page write Buffer
- Self-Timed Write cycle with Auto-Clear
- 100,000 program/Erase cycles
- 100 Year Data Retention
- Optional High Endurance Device Available

### (2) Description

The CAT24C08P is a 8K bit serial CMOS E<sup>2</sup> PROM internally organized as 1024x8bits. The CAT 24C08P features a 16 byte page write buffer.

### (3) Block Diagram

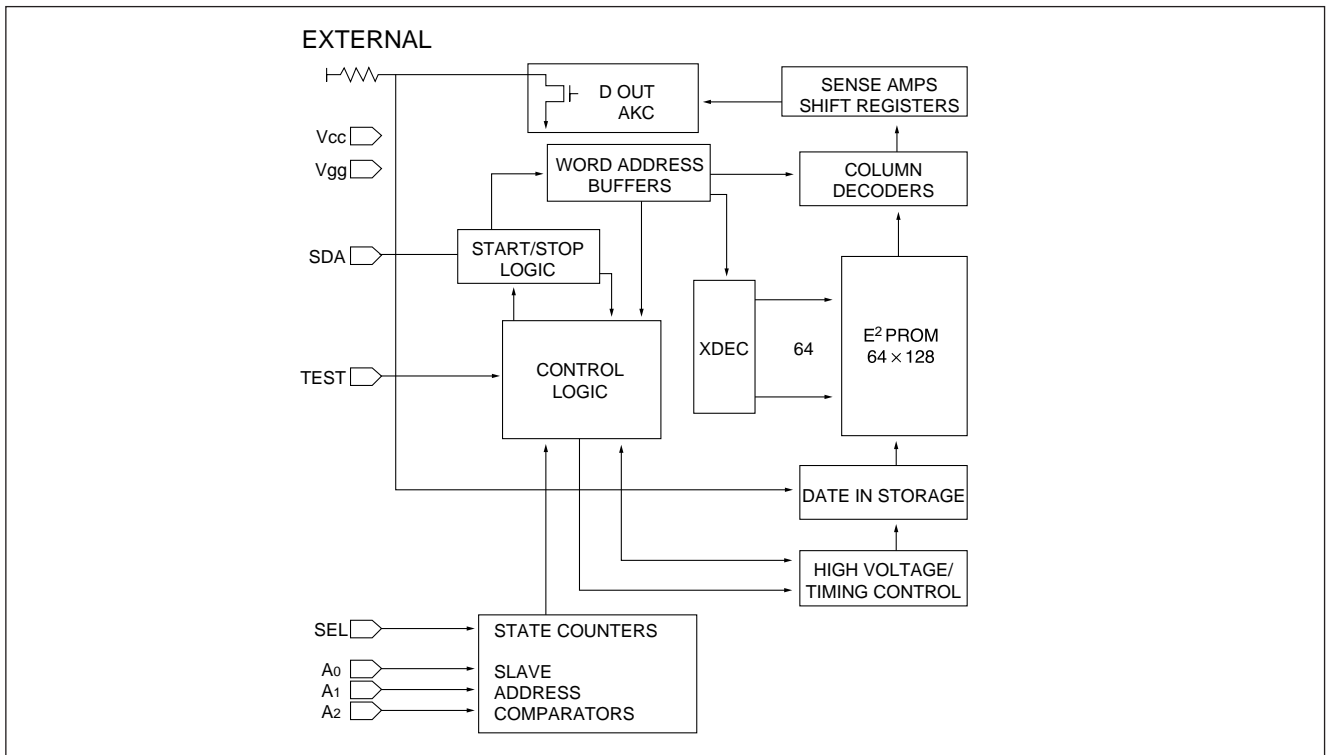

### (4) Pin Description

PIN	SYMBOL	DESCRIPTION
1-3	A0, A1, A2	Device Address Inputs
4	Vss	Ground
5	SDA	Serial Data/Address
6	SCL	Serial Clock
7	TEST	Connect to Vss
8	Vcc	+5V Power supply

---

## TDA8375A (Single chip TV Processor for Negative modulation IF )

### (1) General Description

The TDA8375A is I2C-bus controlled single chip TV processors which are intended to be applied in PAL/NTSC television receiver.

The IC is mounted in a S-DIL 56 envelope.

### (2) Feature

#### • IF

- Vision IF amplifier with high sensitivity and good figures for differential phase and gain
- PLL demodulator with high linearity offering the possibility for (single standard) intercarrier stereo audio application .
- Alignment PLL via I2C
- [TDA8375A] Multistandard IF with negative and positive modulation, switchable via I2C

#### • Video

- Integrated luminance delay line
- Integrated chroma trap and bandpass filters (auto calibrated)
- Asymmetrical peaking circuit in the luminance channel
- Black stretching of non standard CVBS or luminance signals

#### • Colour

- SECAM interface for application with SECAM add-on TDA8395.

#### • RGB

- RGB control (brightness, contrast, saturation)
- Black current stabilization and white point adjustment

#### • Input / Output

- Flexible video source select with CVBS input for the internal signal and two external video inputs(one switchable for CVBS or Y/C).
- The output signal of the video source select is externally available ( also as CVBS when Y/C input is used).
- External audio input.
- Linear RGB input with fast blanking.

#### • Synchronization and Deflection

- Horizontal synchronization with two control loops and alignment free horizontal oscillator.
- Slow start and slow stop of the horizontal drive output to enable low stress start-up and switch-off from the line circuit at nominal line supply voltage.
- Vertical count-down circuit for stable behavior with provisions for non-standard signals.
- Vertical geometry control.
- Vertical drive optimized for DC coupled vertical output stages.

#### • Control

- Full I2C bus control, as well for customer controls as for factory alignment.
- All automatic controls have an option for forced mode.

#### • Power consumption

- Low power consumption (900 mW at 8.0 Volts).

#### • Packaging

- SDIL-56 (Shrunked Dual In Line, 56 pins).

### (3) Block Diagram

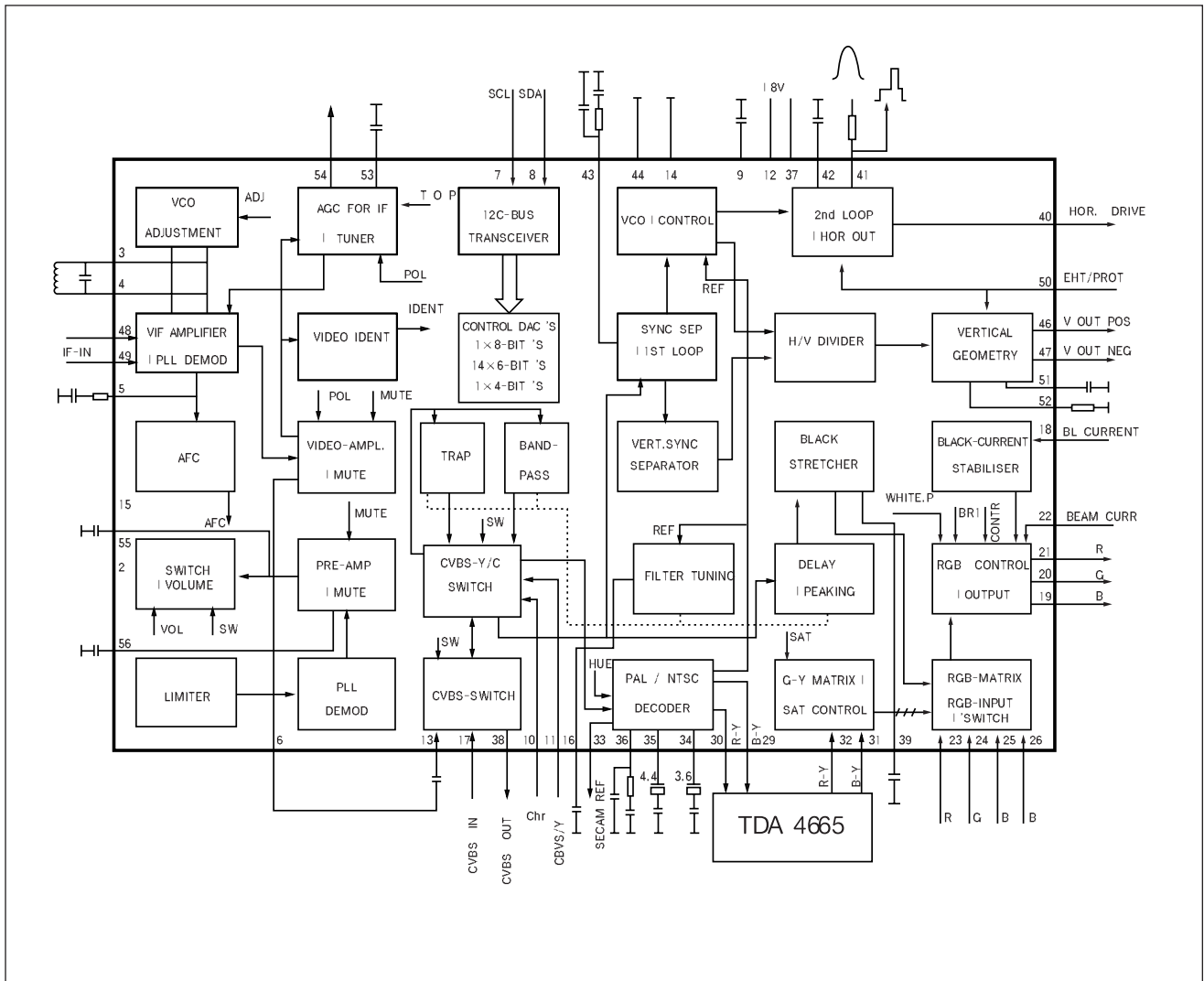



No	Name	Description
1	SOUND IF INPUT	not used.
2	EXT AUDIO INPUT	not used.
3 4	VCO REF FILTER	The IF VCO tuned circuit is applied to these pin. Its resonance frequency must be two times the IF-frequency and in between a range of 64-120MHz. This range is suitable for the IF standards as 33.4, 38.9, 45.75 and 58.75MHz. The VCO frequency can be adjusted by I2C bus so a fixed coil can be used.
5	PLL LOOP FILTER	The PLL loopfilter is a first order filter with R=390 ohm and C = 100nF in series to ground. The loopfilter bandwidth is 60kHz and is optimal for both fast catching and sufficient video suppression for optimal sound performance. Sound performance can theoretically be improved by adding a small capacitor (approx.0- 4.7nF) between pin 5 and ground. This however must be evaluated further because the normal video signal response should not be effected.
6	IF VIDEO OUTPUT	Although the video output impedance is low it is recommended to avoid high frequency current in the output due to for instance sound trap filters. This can be achieved by means of an emitter follower at the video output with a 1 k $\Omega$ resistor in series with the base.
7	BUS INPUT : SCL	Serial clock line
8	BUS INPUT : SDA	Serial data line
9	BANDGAP DECOUPLING	The bandgap circuit provides a very stable and temperature independent reference voltage. This reference voltage (6.7V) ensures optimal performance of the TDA8375 and is used in almost all functional circuit blocks.
10	CHROMA INPUT	The supplied C S-VHS input burst amplitude should be nominally 300mVpp (assumed is a colour bar signal with 75% saturation and with chroma/burst ratio of 2.2/1 ). The C S-VHS input is internally clamped to 4V via 50 k $\Omega$ . The external AC coupling capacitor with 50 k $\Omega$ forms a high pass filter. A recommended coupling capacitor is 1 nF; the high pass filter cut off frequency is then approximately 3KHz.
11	Y/CVBS INPUT	The Y S-VHS signal of 1Vpp ( inclusive sync amplitude) is AC coupled to pin11.
12 37	MAIN POSITIVE SUPPLY	The TDA8375 has a main supply pin 12 and a horizontal supply pin 37. Both pins have to be supplied simultaneously. Notice that the IC has not been designed to use this pin 37 as start pin. (pin 37 supplies the horizontal oscillator, PHI-1 and PHI-2) (pin 12 supplies the rest of the circuits in the IC)  The nominal supply voltage is 8V. With min/max values of 7.2-8.8V. Also in stand-by condition the IC must be supplied with 8V. A voltage detection circuit is connected to both pins. - pin12 if V12 <6.8V than a power on reset, POR, is generated. The Hout output is disabled immediate. - pin37 if V37 <5.8V than the horizontal output is disabled immediate.

No	Name	Description															
13 17	INT CVBS INPUT EXT CVBS INPUT	It is recommended that the CVBS1 int and CVBS2 ext input amplitudes are 1 Vpp (inclusive sync amplitude). This, because the noise detector switches the $\phi$ 1 loop to slow mode (i.e. auto $\phi$ 1 mode when FOA, FOB = 0,0) when noise level exceeds 100mVrms (i.e. at S/N of 20dB).															
14	GROUND	All internal circuits are connected to this ground pin 14.															
15	AUDIO OUTPUT	not used.															
16	DECOUPLING FILTER TUNING	Voltage variations at pin 16, which can be due to external leakage current or crosstalk from interference sources, should be less than 50mV to ensure that tuning of filters/delay cells remains correct.															
18	BLACK CURRENT INPUT	For correct operation of the loop CURRENT information is supplied to the black current input pin.															
19 20 21	BLUE OUTPUT GREEN OUTPUT RED OUTPUT	The RGB outputs are supplied to the video output stages from pins 21, 20 and 19 respectively. For nominal signals (i.e. CVBS/S-VHS, -(R-Y)/-(R-Y), TXT inputs) and for nominal control settings, then the RGB output Signal amplitudes is typically 2VBLACK_WHITE.															
22	V-GUARD INPUT/ BEAM CURRENT LIMITER	<b>Vertical Guard</b> With this function, the correct working of the vertical deflection can be monitored. If the vertical deflection fails, the RGB outputs are blanked to prevent damage to the picture tube. <b>Beam current limiting</b> The beam current limiting function is realised by reducing the contrast (and finally the brightness) when the beam current reaches a too high level. The circuit falls apart in two functions: - Average beam current limiting (ABL): reacting on the average content of the picture - Peak white limiting (PWL): reacting on high local peaks in the RGB signal.															
23 24 25	RED INPUT GREEN INPUT BLUE INPUT	The Rin, Gin, Bin input signals (nominal signal amplitude of 700mV) are AC coupled to pin 23, 24 and 25 respectively. Clamping action occurs during burstkey period.															
26	RGB INSERTION SWITCH INPUT	The table below a survey is given of the three modes which can be selected with a voltage on RGB insertion switch input pin ; <table border="0" style="margin-left: 20px;"> <tr> <td>Vpin26</td> <td>I2C function</td> <td>Selected RGB signal</td> </tr> <tr> <td>0.9V-3V</td> <td>IE1=0</td> <td>RGB(internal)</td> </tr> <tr> <td></td> <td>IE1=1</td> <td>Rin,Gin,Bin</td> </tr> <tr> <td></td> <td></td> <td>(fast insertion on pin23,24,25)</td> </tr> <tr> <td>&gt; 4V</td> <td>IE1=X</td> <td>OSD can be inserted at the RGBout pins</td> </tr> </table>	Vpin26	I2C function	Selected RGB signal	0.9V-3V	IE1=0	RGB(internal)		IE1=1	Rin,Gin,Bin			(fast insertion on pin23,24,25)	> 4V	IE1=X	OSD can be inserted at the RGBout pins
Vpin26	I2C function	Selected RGB signal															
0.9V-3V	IE1=0	RGB(internal)															
	IE1=1	Rin,Gin,Bin															
		(fast insertion on pin23,24,25)															
> 4V	IE1=X	OSD can be inserted at the RGBout pins															
27	LUMINANCE INPUT	An nominal input signal amplitude of 1 Vblack-white MUST be DC coupled to the luminance input pin 27. The pin is internally AC coupled to the luminance clamp via a capacitor of 50pF; clamping action occurs during burstkey period.															
28	LUMINANCE OUTPUT	The luminance output signal is approximately 1 V black-white with typical output impedance of 250 ohm.															

No	Name	Description
29 30	B-Y OUTPUT R-Y OUTPUT	The maximum output impedance of pins 29 and 30 is 500 $\Omega$ when PAL/NTSC signals are identified. When SECAM is identified by the SECAM add-on and no PAL/NTSC is already identified by the ASM, then the ASM sets the -(B-Y)/-(R-Y) output switch open (via DEMSW). This enables the -(B-Y)/-(R-Y) outputs of the TDA8395 to be directly connected to pins 29 and 30 respectively.
31 32	B-Y INPUT R-Y INPUT	The -(B-Y),-(R-Y) output signals (supplied from baseband delay line) are AC coupled, via a coupling capacitor of 10nF or greater, to the -(B-Y)/-(R-Y) inputs; both inputs are clamped during burstkey period.
33	SECAM REF OUTPUT	The SECAM reference output is directly connected to pin I of the TDA8395 for SECAM decoding ; it also can be used as a reference for comb filter applications.
34 35	X-TAL 3.58 X-TAL 4.43	To ensure correct operation of both: - colour processing internal circuits, - sync calibration internal circuits, it is only allowed to have 3.6MHz Xtals on pin34: both 4.4MHz,3.6MHz Xtals are allowed on pin 35. If pin 35 is not used: then it is left open in application (also XA,XB=0,1 ).
36	LOOP FILTER BURST PHASE DETECTOR	One of the important aspects of the PLL is the 1oop filter connected to pin 36; it influences the dynamic performance of the loop.
38	CVBS OUTPUT	The output amplitude is 1Vpp (transfer gain ratio between CVBS1int or CVBS2ext or CVBS3ext/Ys-vhs and CVBSout is 1). The maximum output impedance is 250 ohm.
39	BLACK PEAK HOLD CAPACITOR	For the correct working of the black stretcher an external time constant should be added at the black peak hold capacitor input.
40	HOR OUTPUT	This open collector output is meant to drive the horizontal output stage. The output is active low, i.e. the line transistor should conduct during the low period of the output.
41	SANDCASTLE OUTPUT/ FLYBACK INPUT	Pin 41 is a combined input/output pin. The pin provides a three level sandcastle pulse. Both burstkey pulse and vertical blanking pulse are always available, the line blanking pulse is only present when the external flyback pulse is fed to this pin. The line flyback pulse, fed to this pin is used for two functions: - input signal for the PHI-2 1oop and - RGB line blanking. (without flyback pulse blanking occurs only during the burstkey pulse) To ensure correct working of the delay line and SECAM add-on, the output should not be loaded with more than: - Sandcastle input delay line TDA 4665 - Sandcastle input SECAM add-on TDA 8395
42	PHI-2 FILTER / FLASH PROTECT	The loopfilter is a first order filter. This pin requires a capacitor (C) only. A flash protection becomes active when this pin is forced >6V. The horizontal drive is switched-off immediately. Once the voltage is <6V the horizontal drive is switched-on again via the slow start procedure.

No	Name	Description
43	PHI-1 FILTER	The loopfilter connected to pin 43 is suitable for various signal conditions as strong/weak and VCR signal. This is achieved by switching of the loopfilter time constant by changing the PHI-1 output current. Via I2C bus FOA/B, different time constants can be chosen, including an automatic mode which gives optimal performance under varying conditions.
44	GROUND	To this pin are connected the IC-substrate and horizontal output.
45	EAST-WEST DRIVE	The EW drive is a current output. The output is single-ended and is fed directly to the EW-input terminal
46 47	VERT DRIVE + VERT DRIVE -	The vertical drive has a current output. The output is balanced which ensures a good common mode behavior with temperature and makes the output signal less sensitive for disturbances.
48 49	IF INPUT	The PLL frequency range is 32-60MHz with corresponding VCO frequency 64-120MHz. The IF input impedances is 2 k $\Omega$ in parallel with 3pF and matches the required load for commonly used SAW filters. A DC coupling is allowed, so no series capacitors between SAW filter and IF input are necessary.
50	EHT/OVERVOLTAGE PROTECT INPUT	The input range for EHT tracking is 1.2 ~ 2.8V, for a compensation of +/- 5% on vertical and/or EW. The tracking on EW can be switched on/off by HCO. The overvoltage protection is activated when the voltage on pin 50 exceeds 3.9V typical.
51	VERT SAWTOOTH CAPACITOR	This pin requires a capacitor to ground of 100nF +/- 5%. The optimal sawtooth amplitude is 3.5V and is determined by the external capacitor and charge current. The sawtooth bottom-level is 2V.
52	REFERENCE CURRENT INPUT	This pin requires a resistor to ground. The optimal reference current is 100 $\mu$ A. which is determined by this resistor.
53	AGC DECOUPLING CAPACITOR	The AGC capacitor value is 2.2 $\mu$ F and has been defined for an optimal compromise between AGC speed and tilt for all AGC modes (negative/positive modulation).
54	TUNER AGC OUTPUT	This output is used to control (reduce) the tuner gain for strong RF signals. The tuner AGC is an open collector output which is acting as a variable current source to ground.
55	AUDIO DEEMPHASSIS	not used.
56	DECOUPLING SOUND DEMODULATOR	This pin requires a capacitor of 10 $\mu$ F connected to ground. The pin acts as a low pass filter needed for the DC feedback loop.

# TDA4665(Base Band Delay Line)

## (1) Features

- Two comb filters, using the switched-capacitor technique, for one line delay time (64µs)
- Adjustment free application
- No crosstalk between SECAM colour carriers
- Handles negative or positive colour-difference input signals
- Clamping of AC-coupled input signals(±(R-Y)and±(B-Y))
- VCO without external components
- 3MHz internal clock signal derived from a 6MHz VCO, line-locked by the sandcastle pulse (64µs line)
- Sample-and -hold circuits and low-pass filters to suppress the 3 MHz clock signal
- Addition of delayed and non-delayed output signals
- Output buffer amplifiers
- Comb filtering functions for NTSC colour-difference signals to suppress cross-colour

## (2) General Description

The TDA4661 is an integrated baseband delay line circuit with one line delay. It is suitable for decoders with colour-difference signal outputs±(R-Y)and±(B-Y).

## (3)Block Diagram

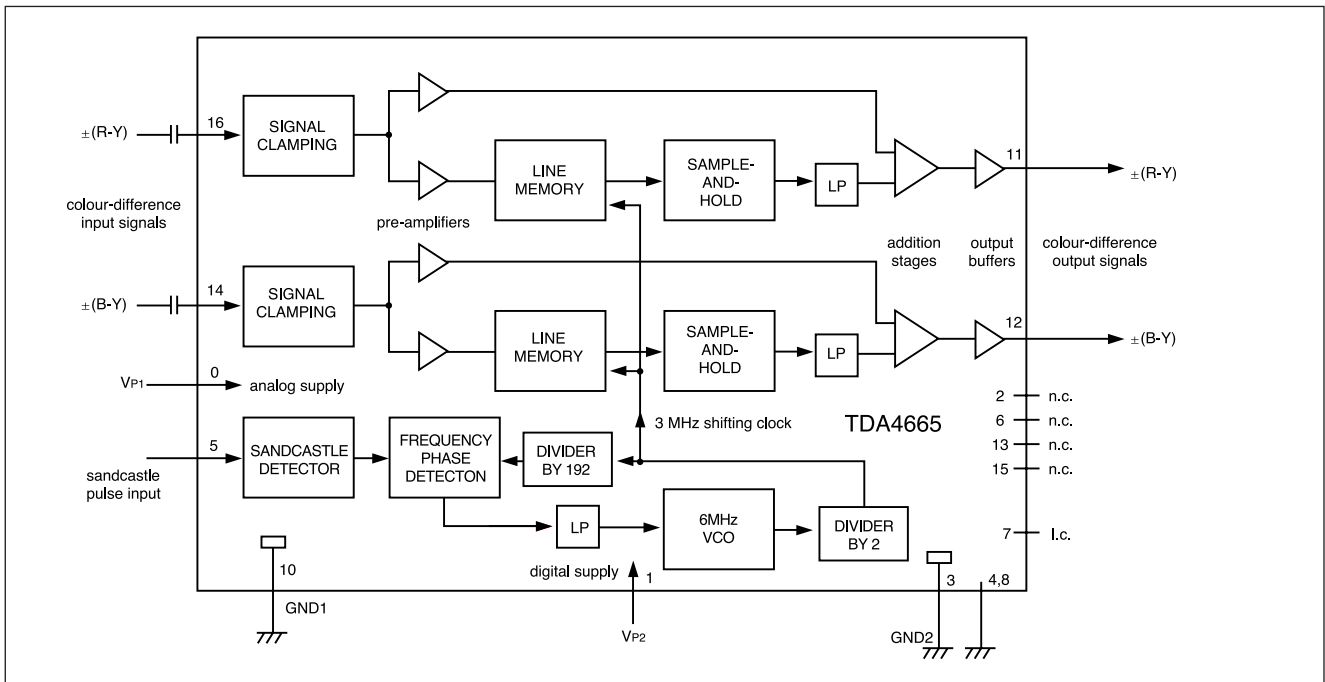

## (4) Pin Description

SYMBOL	PIN	DESCRIPTION
V <sub>p2</sub>	1	+5V supply voltage for digital part
n.c.	2	not connected
GND2	3	ground for digital part (0V)
i.c.	4	internally connected
SAND	5	sandcastle pulse input
n.c.	6	not connected
i.c.	7	internally connected
i.c.	8	internally connected

SYMBOL	PIN	DESCRIPTION
V <sub>p1</sub>	9	+5V supply voltage for analog part
GND1	10	ground for analog part (0V)
V <sub>0</sub> (R-Y)	11	± (R-Y) output signal
V <sub>0</sub> (B-Y)	12	± (B-Y) output signal
n.c.	13	not connected
V <sub>1</sub> (B-Y)	14	± (B-Y) input signal
n.c.	15	not connected
V <sub>1</sub> (R-Y)	16	± (R-Y) input signal

## TDA8395 (Secam Decoder)

### (1) Features

- Fully integrated filters
- Alignment free
- For use with baseband delay

### (2) Description

The TDA8395 is a self-calibrating, fully integrated SECAM decoder. The IC should preferably be used in conjunction with the PAL/NTSC decoder TDA8362 and with the switch capacitor baseband delay circuit TDA4665. The IC incorporates HF and LF filters, a demodulator and an identification circuit (luminance is not processed in this IC).

A highly stable reference frequency is required for calibration and a two-level sandcastle pulse for blanking and burst gating.

### (3) Block Diagram

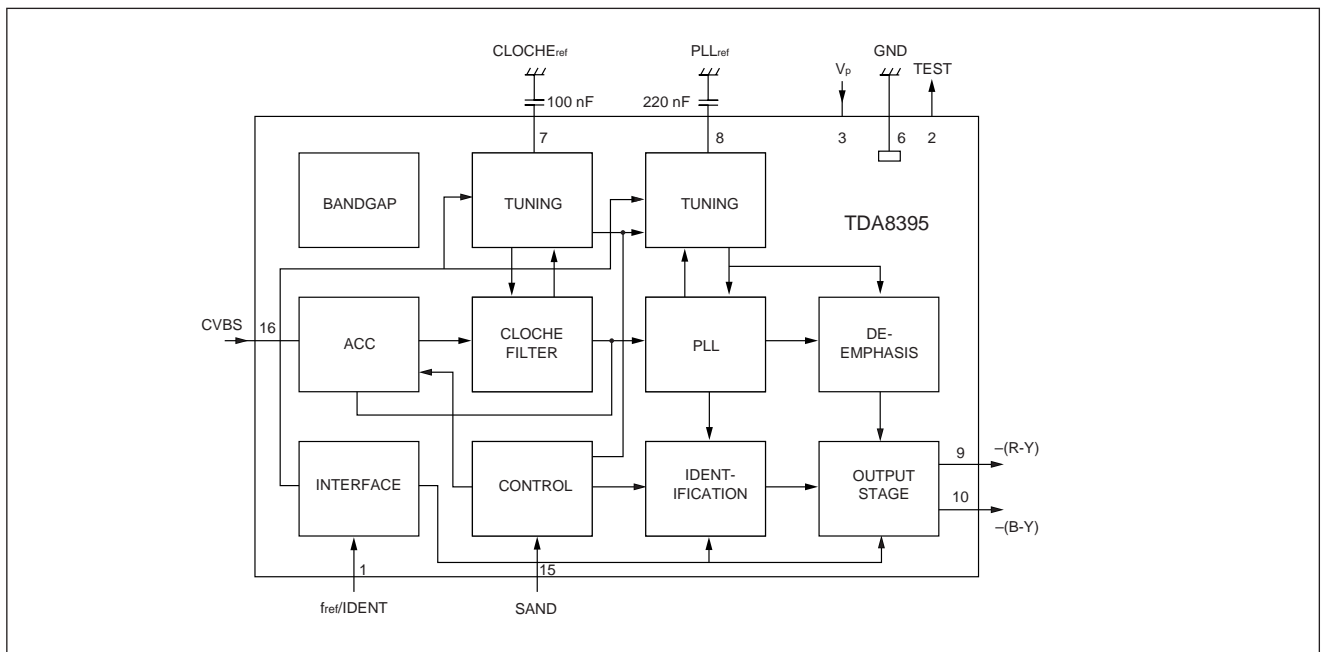

### (4) Pin Description

SYMBOL	PIN	DESCRIPTION
f <sub>p1</sub> /IDENT	1	reference frequency input/identification input
TEST	2	test output
V <sub>p</sub>	3	positive supply voltage
n.c.	4	not connected
n.c.	5	not connected
GND	6	ground
CLOCHE <sub>ref</sub>	7	Cloche reference filter
PLL ref	8	PLL reference
-(R-Y)	9	-(R-Y) output
-(B-Y)	10	-(B-Y) output
n.c.	11	not connected
n.c.	12	not connected
n.c.	13	not connected
n.c.	14	not connected
SAND	15	sandcastle pulse input
CVBS	16	video (chrominance) input

## TDA6106Q ( Video Output Amplifier )

### (1) General Description

The TDA6106Q is a monolithic video output amplifier (5MHz bandwidth) in a SIL 9 MPpackage, using high-voltage DMOS technology, and is intended to drive the cathode of CRT directly .

To obtain maximum performance, the amplifier should be used with black-current control.

### (2) Feature

- Black - current measurement output for automatic black current stabilization (ABS)
- Single supply voltage of 200V
- Internal protection against positive appearing CRT flash-over discharge
- Protection against ESD
- Internal 2.5V reference circuit
- Controllable switch-off behavior

### (3) Block Diagram

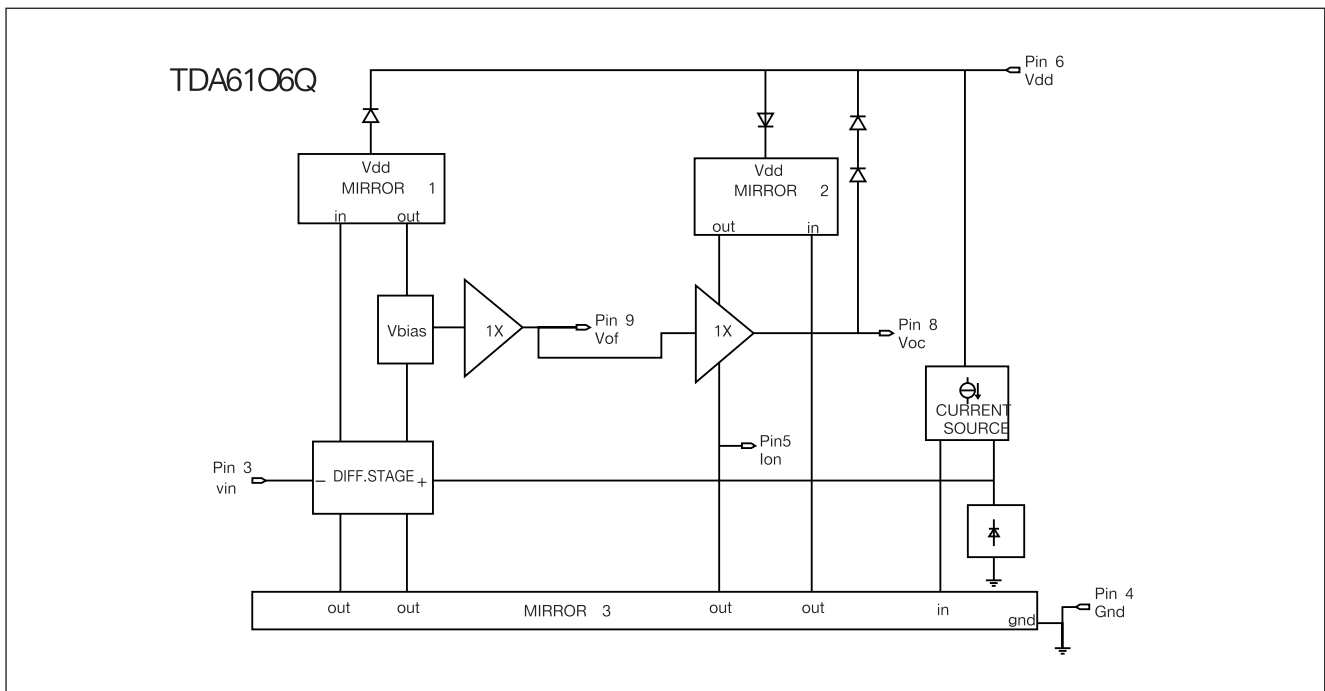

### (4) Pin Description

PIN	SYMBOL	DESCRIPTION
1		N.C
2		N.C
3	V in	inverting input
4	GND	ground, substrate
5	I om	Black-current measurement output
6	V dd	supply voltage high
7		N.C
8	V oc	cathode output
9	V of	feedback/transient output

## TDA8351 (DC-coupled vertical deflection circuit)

### (1) General Description

The TDA8351 is power circuit for use in 90° and 110° color deflection systems for field frequencies of 50 to 120 Hz. The circuit provides a DC driven vertical deflection output circuit, operating as a high efficient class G system.

### (2) Feature

- High efficient fully DC-coupled vertical output bridge circuit
- Vertical fly-back switch
- Guard circuit
- Protection against : - short circuit of the output pins (7 and 4)  
- short circuit of the output pins to  $V_p$
- Temperature (thermal) protection
- High EMC immunity because of common mode inputs
- A guard signal in zoom mode.

### (3) Block Diagram

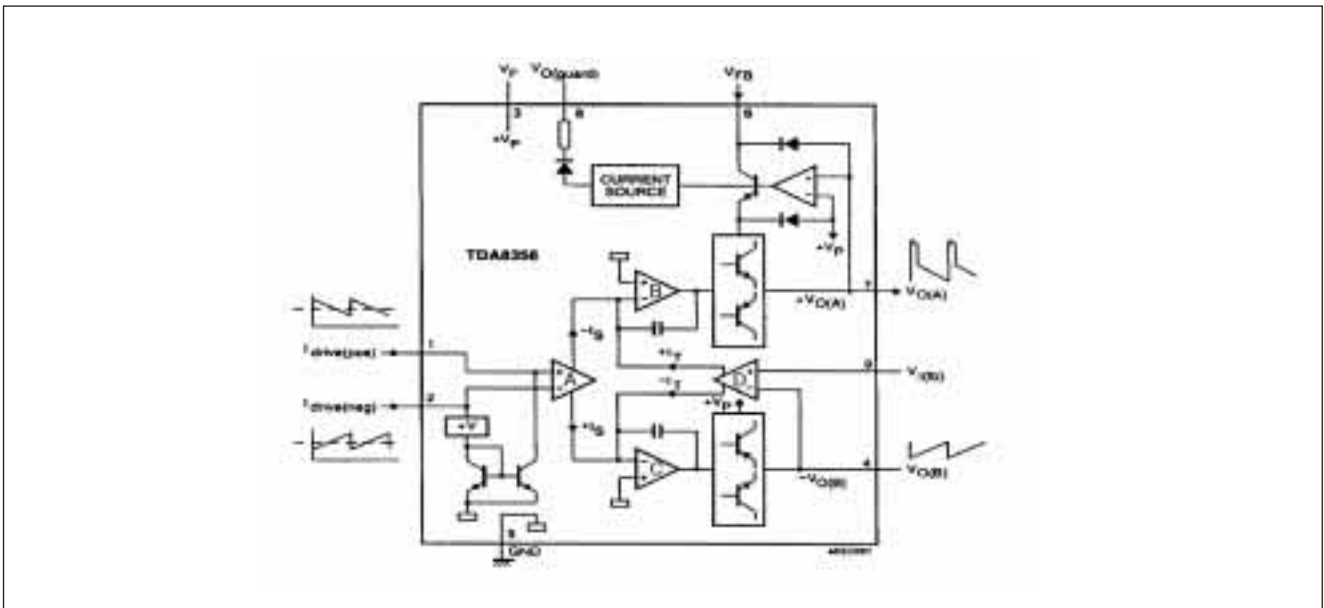

### (4) Pin Description

PIN	SYMBOL	DESCRIPTION
1	I drive (pos)	input power stage (positive); include Ii(sb) signal bias
2	I drive (neg)	input power stage (negative); include Ii(sb) signal bias
3	V p	operating supply voltage
4	V o(b)	output voltage B
5	GND	ground
6	V fb	input fly-back supply voltage
7	V o(a)	output voltage A
8	V o(guard)	guard output voltage (Not used)
9	V I(fb)	input feedback voltage



# STR-S5707 (Hybrid IC for a Switching Regulator)

## (1) General Description

The STR-S5707 is a Hybrid IC with a built in power transistor and a separate excitation control IC, designed for converter type switching mode power supply applications. The IC is capable of quasi-resonant mode and requires small number of external component.

## (2) Feature

- Small SIP isolated package : Resin sealed type (transfer mold)
- Lower power dissipation at a lighter load
- Many protection function : - Pulse-by-pulse over current protection
  - Over-voltage protection with a latch
  - Thermal protection with a latch
- These protection functions are incorporated and can be latched with an external signal.

## (3) Block Diagram

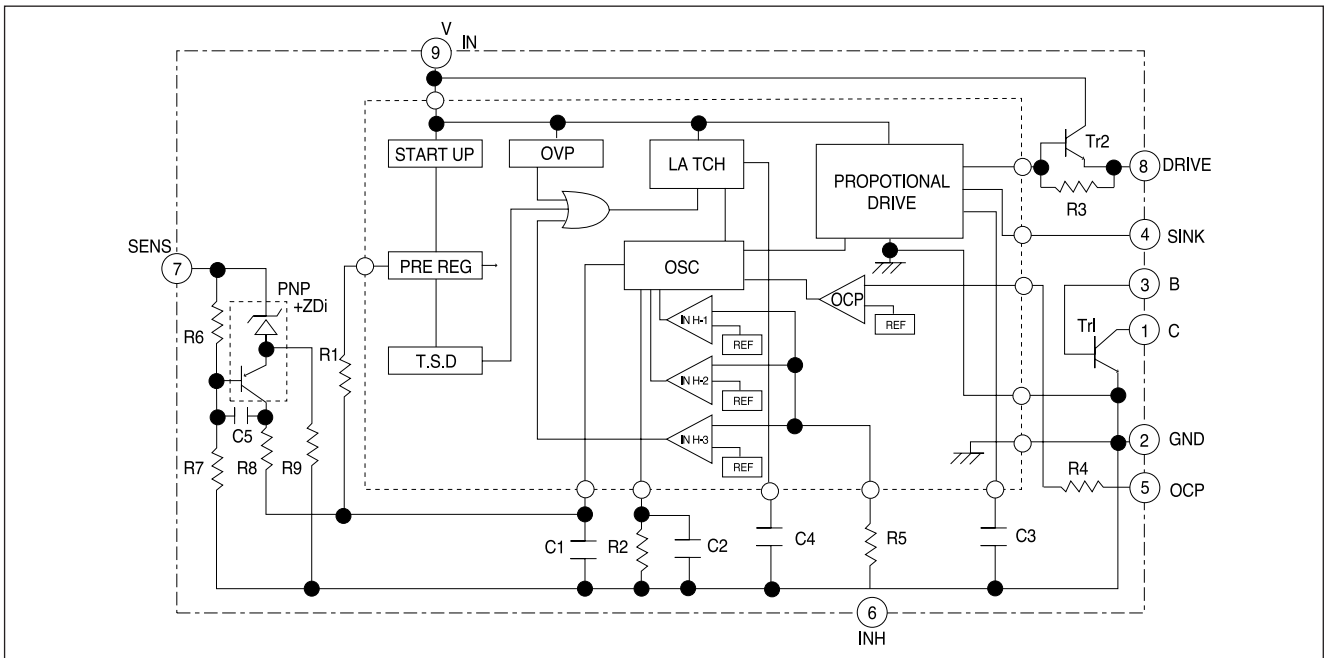

## (4) Pin Description

PIN	NAME	SYMBOL	DESCRIPTION
1	Collector	C	Collector of power Tr
2	Ground	GND	ground (Emitter of power Tr)
3	Base	B	Base of power Tr
4	Sink	SINK	Base current (IS) input
5	Over-current protection	OCP	over-current sensing signal input
6	Inhibit Latch	INH	input for synchronizing OFF time and latch circuit operation
7	Sensing	SENS	constant voltage control signal input
8	Drive	DRIVE	Base drive current (ID) output
9	Vin	VIN	supply voltage for control circuit

**Electrical Characteristics of Control Part (Ta=25℃)**

Description	Terminal	Symbol	Rating			Unit
			MIN	TYP	MAX	
On-state Voltage	9-2	V <sub>IN(ON)</sub>	7.6	8	8.4	V
Off-state Voltage	9-2	V <sub>IN(OFF)</sub>	4.6	4.9	5.2	V
Operating Circuit Current	9-2	I <sub>IN(ON)</sub>	15	—	28	mA
Stand-by Circuit Current	9-2	I <sub>IN(OFF)</sub>	—	—	200	μA
On Time	—	T <sub>ON</sub>	33	—	41	μsec
Off Time	—	T <sub>OFF</sub>	45	—	55	μsec
OCP terminal Threshold Voltage	6-2	V <sub>OCP</sub>	-1.12	-1	-0.88	V
INH terminal Threshold Voltage 1	8-2	V <sub>INH-1</sub>	0.65	0.75	0.85	V
INH terminal Threshold Voltage 2	8-2	V <sub>INH-2</sub>	—	1.4	2.0	V
INH terminal Threshold Voltage 3	8-2	V <sub>Latch</sub>	3.2	5.1	5.8	V
OVP Operating Voltage	9-2	V <sub>IN(OVP)</sub>	9.2	—	10.7	V
Latch Circuit Sustaining Current	9-2	I <sub>H</sub>	—	—	500	μA
Latch Circuit Cancellation Voltage	9-2	V <sub>IN(La.OFF)</sub>	2.5	3.1	—	V
MIC Thermal Shutdown Starting Temp	—	T <sub>j(TSD)</sub>	125	150	—	℃
Fixed Reference Voltage	7-2	V <sub>s</sub>	32.0±0.3			V
Temperature Coefficient of Reference Voltage	7-2	—	—	+2.5	—	mV/℃

**Electrical Characteristics of Power Transistor Part(Trl) (Ta=25℃)**

Description	Terminal	Symbol	Rating			Unit
			MIN	TYP	MAX	
Collector Saturation Voltage	1-2	V <sub>CE(sat)</sub>	—	—	0.4	V
Collector Cutoff Current	1-2	I <sub>CEx</sub>	—	—	100	μA
Base-Emitter saturation voltage	3-2	V <sub>BE(sat)</sub>	—	—	1.5	V
DC Current Gain	—	h <sub>FE</sub>	29	—	61	—
Thermal Resistance	—	θ <sub>j-F</sub>	—	—	1.3	℃/W
Switching Time	1-2	t <sub>s</sub>	—	—	15	μsec
	1-2	t <sub>f</sub>	—	—	0.5	

## TDA8138 (5.1V+12V regulator with Disable and Reset)

### (1) General Description

The TDA8138 is a monolithic dual positive voltage regulator designed to provide fixed precision output voltages of 5.1V and 12V at currents up to 1A.

An internal reset circuit generates a reset pulse when the output 1 decreases below the regulated voltage value.

Output 2 can be disabled by TTL input.

Short circuit and thermal protections are included.

### (2) Feature

- output currents up to 1A
- fixed precision Output 1 voltage  $5.1V \pm 2\%$
- fixed precision Output 2 voltage  $12V \pm 2\%$
- output 1 with Reset facility
- output 2 with Disable by TTL input
- short circuit protection at both outputs
- thermal protection
- low drop output voltage

### (3) Block Diagram

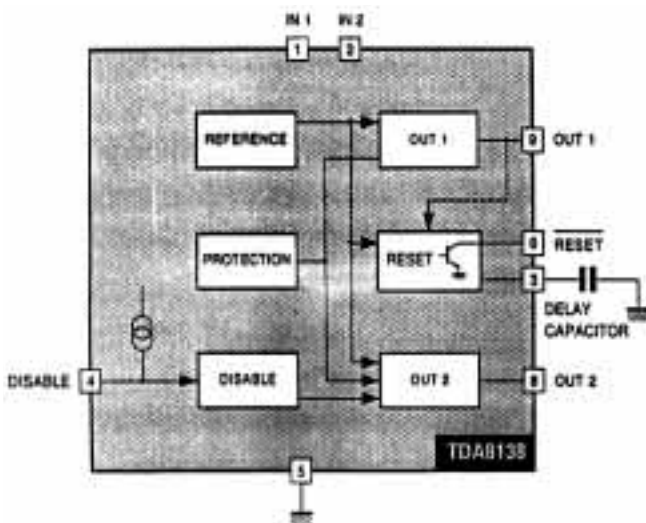

### (4) Pin Description

PIN	SYMBOL	DESCRIPTION
1	V in 1	input 1
2	V in 2	input 2
3	C e	Delay capacitor
4	V dis	disable
5	GND	ground
6	RST	reset
7		n.c
8	V out 2	output 2 (12V)
9	V out 1	output 1 (5.1V)

## TDA1519B (BTL or STEREO audio amplifier)

### (1) Features

- Requires very few external components for Bridge Tied Load (BTL)
- Stereo or BTL application
- High output power
- Low offset voltage at output (important for BTL)
- Fixed gain
- Good ripple rejection
- Mute/stand-by switch
- Load dump protection
- SC and DC short-circuit-safe to ground and VP

- Thermally protected
- Reverse polarity safe
- Capability to handle high energy on outputs (VP = 0 V)
- No switch-on/switch-off plop
- Protected against electrostatic discharge
- Identical inputs (inverting and non-inverting)
- Compatible with TDA1519A (except output power)

### (2) General Description

The TDA1519B is an integrated class-B dual output amplifier in a 9-lead single in-line (SIL) plastic medium power package. The device is primarily developed for car radio applications.

### (3) Block Diagram

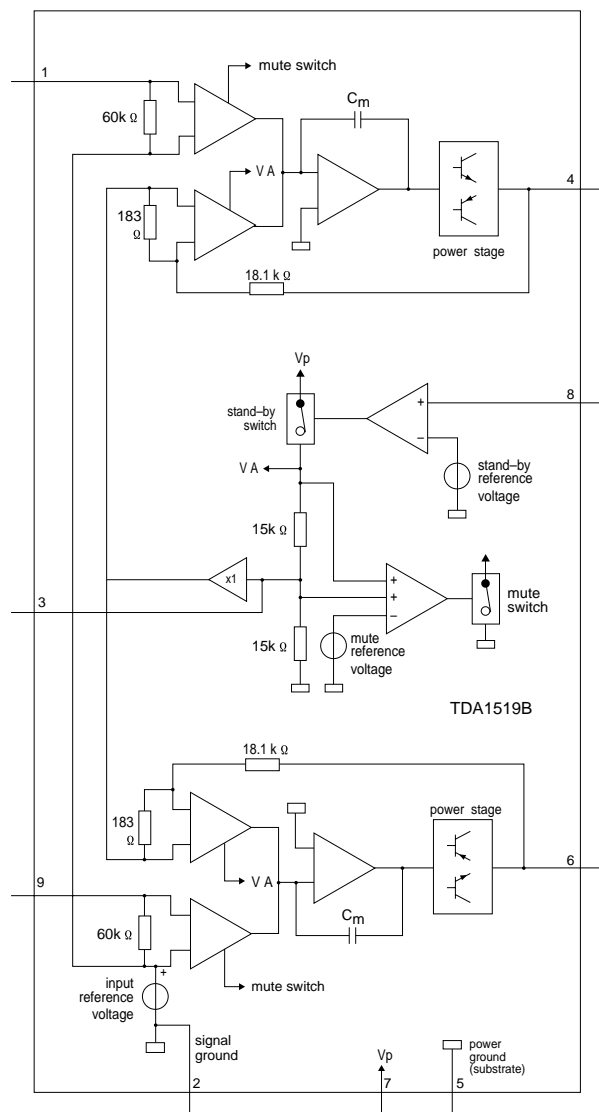

### (4) Pin Description

PIN	NAME	DESCRIPTION
1	NINV	non-inverting input
2	GND1	ground (signal)
3	RR	supply voltage ripple rejection
4	OUT1	output 1
5	GND2	ground (substrate)
6	OUT2	output 2
7	Vp	positive supply voltage
8	M/SS	mute/stand-by switch
9	INV	inverting input

# MSP3410 (Multistandard Sound processor for NICAM & 2-Carrier)

## (1) Features

- Asingle-chip Multistandard Sound Pressor for applications in analog and digital TV sets
- TWO selectable analog inputs
- Automatic Gain control for analog input
- All demoudlation and filtering is performed on chip and is individually programmable
- Adjustment of volume, balance, loudness, treble, bass, base width enlargement, pseudo stereo
- Independent input selection for speaker-out and scart-out

## (2) Block Diagram

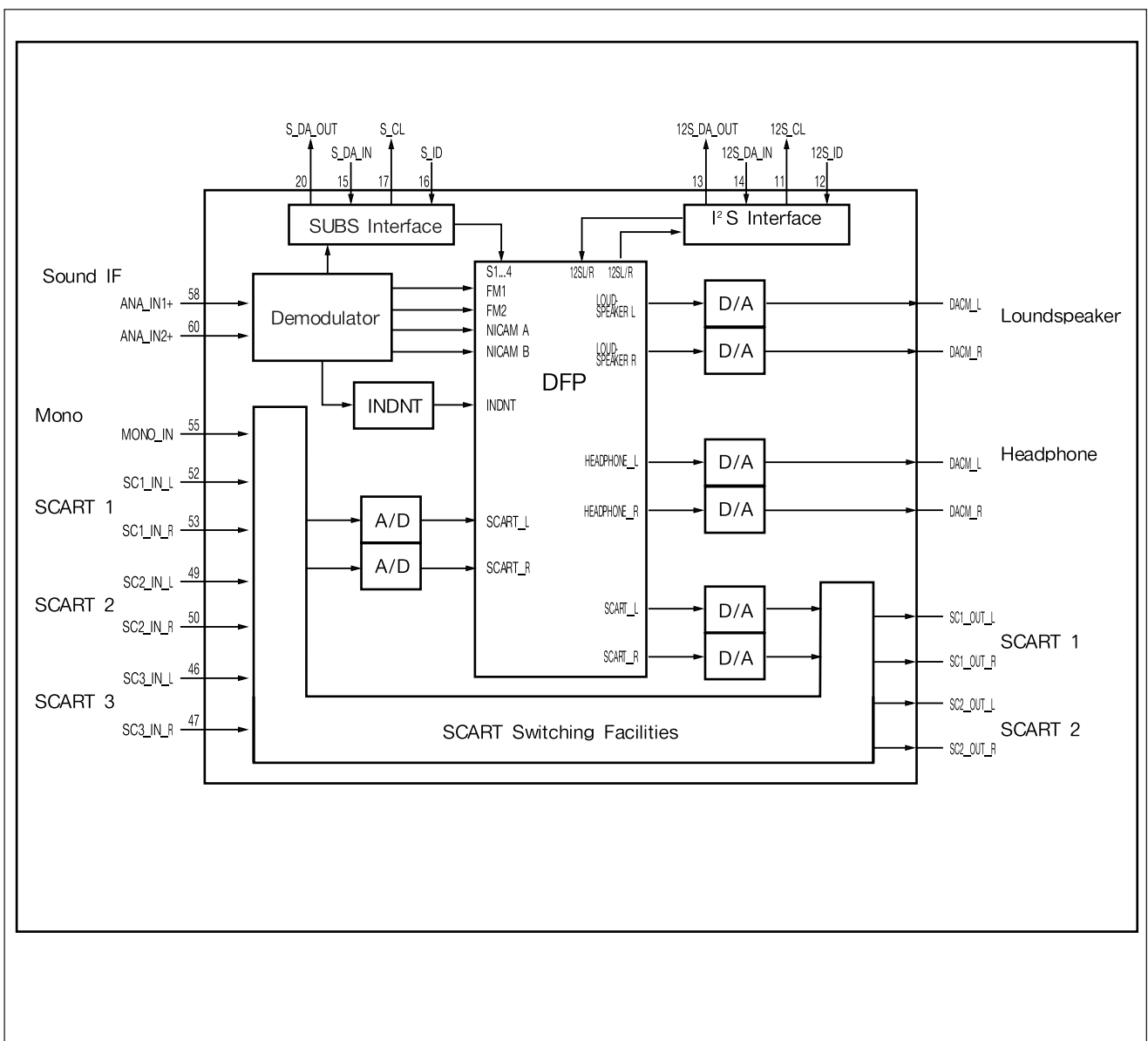

---

### (3) Description

- Analog Sound IF - Input Section

The input pins ANA\_IN1+, ANA\_IN2+ and ANN\_IN-offer the possibility to connect two different sound IF sources to the MSP 3410. By means of bit [8] of AD\_CV either terrestrial or satellite sound IF signals can be selected. The analog-to-digital conversion of the preselected sound IF signal is done by a flash-converter, whose output can be used to control an analog automatic gain circuit (AGC), providing optimum level for a wide range of input levels. It is possible to switch between automatic gain control and a fixed (setable) input gain. In the optimum case, the input range of the AD converter is completely covered by the sound if source. Some combinations of SAW filters and sound IF mixer IC's however show large picture components on their outputs. In this case filtering is recommended. It was found, that the high pass filters formed by the coupling capacitors at pins ANA\_IN1+ and ANA\_IN2+ are sufficient in most cases.

- Quadrature Mixers

The digital input coming from the integrated A/D converter may contain audio information at a frequency range of theoretically 0 to 9 MHz corresponding to the selected standards. By means of two programmable quadrature mixers two different audio sources, for example NICAM and FM-mono, may be shifted into baseband position. In the following the two main channels are provided to process either:

- NICAM (channel 1) and FM mono (channel 2) simultaneously or alternatively
- FM2 (channel 1) and FM1 (channel2).

Two independent digital oscillators are provided to generate two pairs of sin/cos-functions. Two programmable increments, to be divided up into Low- and High part, determine frequency of the oscillator, which corresponds to the frequency of the desired audio carrier.

- Lowpass Filtering Block for Mixed Sound IF Signals

By means of decimation filters the sampling rate is reduced. Then, data shaping and/or FM bandwidth limitation is performed by a linear phase Finite Impulse Response (FIR-filter). Just like the oscillators' increments the filter coefficients are programmable and are written into the IC by the CCU via the control bus. Thus, for example, different NICAM versions can easily be implemented. Two not necessarily different sets of coefficients are required, one for channel 1 (NICAM or FM2) and one for channel 2 (FM1=FM-mono).

Since both MSP channels are designed to process the German FM Stereo System with the same FIR coefficient set (despite 7 dB power level difference of the two sound carriers), the MSP channel 1 has an internal overall gain of 6 dB. To process two carriers of identical power level these 6 dBs have to be taken into account by decreasing the values of the channel 1 coefficient set.

- CORDIC Block

The filtered sound IF signals are demodulated by transforming the incoming signals from Cartesian into polar format by means of a CORDIC processor block. On the output, the phase and amplitude is available for further processing. AM signals are derived from the amplitude information whereas the phase information serves for FM and NICAM (DQPSK) demodulation.

- Differentiators

FM demodulation is completed by differentiation the phase information output of the CORDIC block.

- Lowpass Filer Block for Demodulated Signals

The demodulated FM and AM signals are further lowpass filtered and decimated to a final sampling frequency of 32 kHz. The usable bandwidth of the final baseband signals is about 15 kHz.

- DQPSK-Decoder

In case of NICAM-mode the phase samples are decoded according the DQPSK-Coding scheme. The output of this block contains the original NICAM-bitstream, which is available at the N-Bus interface.

- NICAM-Decoder

Before any NICAM decoding can start, the MSP must lock to the NICAM frame structure by searching and synchronizing to the so-called Frame Alignment Words (FAW).

To reconstruct the original digital sound samples the NICAM-bitstream has to be descrambled, deinterleaved and rescaled. Also bit error detection and correction (concealment) is performed in this NICAM specific block.

To facilitate the Central Control Unit CCU to switch the TV-set to the actual sound mode, control information on the NICAM mode and bit error rate are supplied by the the NICAM-Decoder, It can be read out via the I<sup>2</sup>C-Bus.

- Analog Section and SCART Switches

The analog input and output sections offer a wide range of switching facilities, which are shown in Fig. To realize a TV-set with 3 pairs of SCART-inputs and two pairs of SCART-outputs no external switching hardware is required.

The switches are controlled by the ACB bits defined in the audio processing interface (see chapter “programming the audio processing part”).

If the MSP 3410 is switched off by first pulling STANDBYQ low and then disconnecting the 5V but keeping the 8V power supply (**‘Standby’-mode**), the switches S1, S2 and S3 maintain their position and function. This facilitates the copy from selected SCART-inputs to SCART-outputs in the TV-sets standby mode.

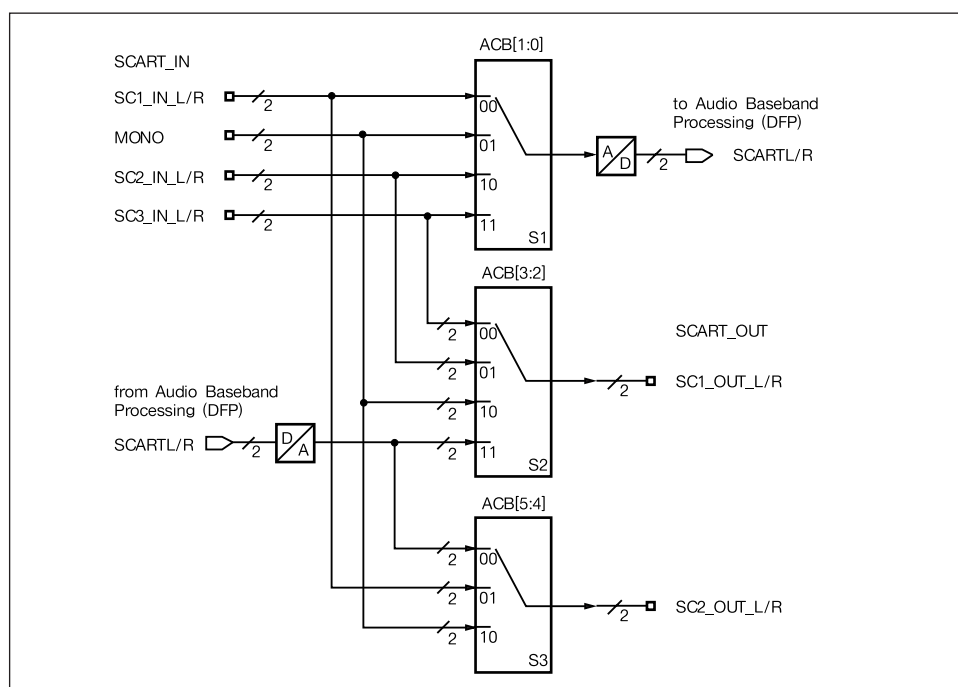

Fig. SCART-Switching Facilities Bold lines determine the default configuration

---

In case of power-on start or starting from standby, the IC switches automatically to the default configuration, shown in the figure above. This action takes place after the first I<sup>2</sup>C transmission into the DFP part. By transmitting the ACB register first, the default setting mode can be changed.

- MSP 3410 Audio Baseband Processing

By means of the DFP processor all audio baseband functions are performed by digital signal processing (DSP). The DSP functions are grouped into three processing parts: Input preprocessing, channel selection and channel postprocessing.

The input preprocessing is intended to prepare the various signals of all input sources in order to form a standardized signal at the input to the channel selector. The signals can be adjusted in volume, are processed with the appropriate deemphasis and are dematrixed if necessary.

Having prepared the signals that way, the channel selector makes it possible to distribute all possible source signals to the desired output channels.

Of special importance is the ability to route in an external coprocessor for special effects like graphic equalizer, surround processing and sound field processing. Routing can be done with each input source and output channel via the I<sup>2</sup>S inputs and outputs.

All input and output signals can be processed simultaneously with the exception that FM2 cannot be processed at the same time as NICAM. Note that the NICAM input signals are only available in the MSP 3410 version. While processing the adaptive deemphasis, no dual carrier stereo (German or Korean) or NICAM processing is possible. Identification values are not valid either.

- Dual Carrier FM Stereo/Bilingual Detection

In the German and Korean TV standard, audio information can be transmitted in three modes: Mono, stereo or bilingual. To obtain information about the current audio operation mode, the MSP 3410 detects the so-called identification signal. Information is supplied via the Stereo Detection Register to an external CCU.

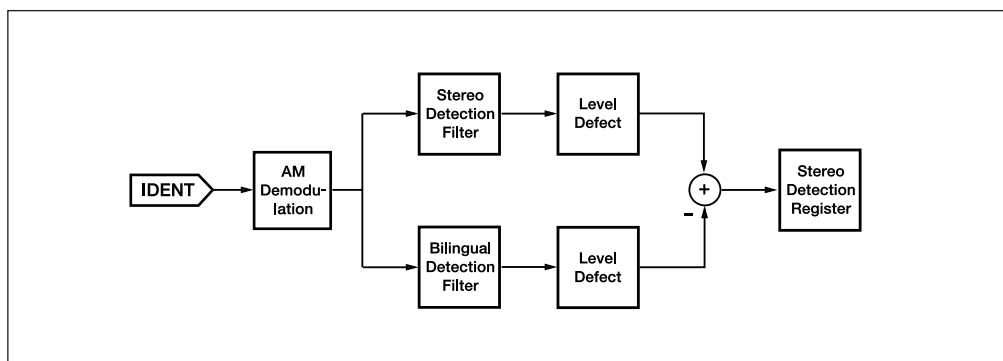



#### (4) Pin Description

PIN	PIN NAME	DESCRIPTION
1	AUD_CL_OUT	Audio clock output
2	CW_CL	Pay-TV control clock
3	CW_DA	Pay-TV control data
4	D_CTR_OUT1	Digital control output 1
5	D_CTR_OUT0	Digital control output 0
6	ADR_SEL	Control bus address select
7	STANDBYQ	Standby (low-active)
8	D_CTR_IN 0	For future use
9	I <sup>2</sup> C_CL	I <sup>2</sup> C clock
10	I <sup>2</sup> C_DA	I <sup>2</sup> C clock
11	I <sup>2</sup> S_CL	I <sup>2</sup> S clock
12	I <sup>2</sup> S_WS	I <sup>2</sup> S wordstrobe
13	I <sup>2</sup> S_DA_OUT	I <sup>2</sup> S data output
14	I <sup>2</sup> S_DA_IN	I <sup>2</sup> S data input
15	S_DA_IN	SBUS data input
16	S_ID	SBUS ident
17	S_CL	SBUS clock
18	DVSUP	Digital power supply +5V
19	DVSS	Digital ground
20	S_DA_OUT	SBUS data output (FM/NICAM-test)
21	FRAME	NBUS frame
22	N_CL	NBUS clock
23	N_DA	NBUS data
24	RESETQ	Power-on-reset
25	DACA_R	Analog output AUX, right
26	DACA_L	Analog output AUX, left
27	VREF2	Reference ground2 high voltage part
28	DACM_R	Analog output MAIN, right
29	DACM_L	Analog output MAIN, left
30	TESTIO2	Test pin 2
31	C_DACS_R	SCART output capacitor to ground
32	C_DACS_L	SCART output capacitor to ground
33	SC2_OUT_R	SCART output2, right
34	SC2_OUT_L	SCART output2, left
35	VREF1	Reference ground1 high voltage part
36	SC1_OUT_R	SCART output, right
37	SC1_OUT_L	SCART output, left
38	CAPL_A	Volume capacitor AUX
39	AHVSUP	Analog power supply 8V
40	CAPL_M	Volume capacitor MAIN

PIN	PIN NAME	DESCRIPTION
41	AHVSS	Analog ground
42	AGNDC	Analog reference voltage high voltage part
43	PDMC1	Capacitor to BAGNDI
44	PDMC2	Capacitor to BAGNDI
45	BAGNDI	Buffered AGNDC
46	SC3_IN_L	Scart input3 in, left
47	SC2_IN_R	Scart input3 in, right
48	ASG2	Analog Shield Ground2
49	SC2_IN_L	Scart input2 in, left
50	SC2_IN_R	Scart input2 in, right
51	ASG1	Analog Shield Ground1
52	SC1_IN_L	Scart input1 in, left
53	SC1_IN_R	Scart input1 in, right
54	VREFTOP	Reference voltage IF A/D converter
55	MONO_IN	Mono input
56	AVSS	Analog ground
57	AVSUP	Analog power supply +5V
58	ANA_IN1+	IF input1
59	ANA_IN1-	IF common
60	ANA_IN2+	IF input (if ANA_IN1+ is used only, connect to AVSS with 50pF Capacitor)
61	TESTIO1	Test pin1
62	XTAL_IN	Crystal oscillator
63	XTAL_OUT	Crystal oscillator
64	DMA_SYNC	DMAC-sync: signal

## TDA4445B (Quasi Parallel Sound Processor)

### (1) Features

- Very high input sensitivity
- Excellent signal to noise ratio
- Fast averaged AGC
- IF amplifier can be switched off for VTR mode
- Output signal stabilized against supply voltage variations
- Very few external components
- Targeting bistandard applications
- Low AM distortion

### (2) General Description

The TDA4445B is quasi parallel sound processor with quadrature intercarrier demodulator.

### (3) Block Diagram

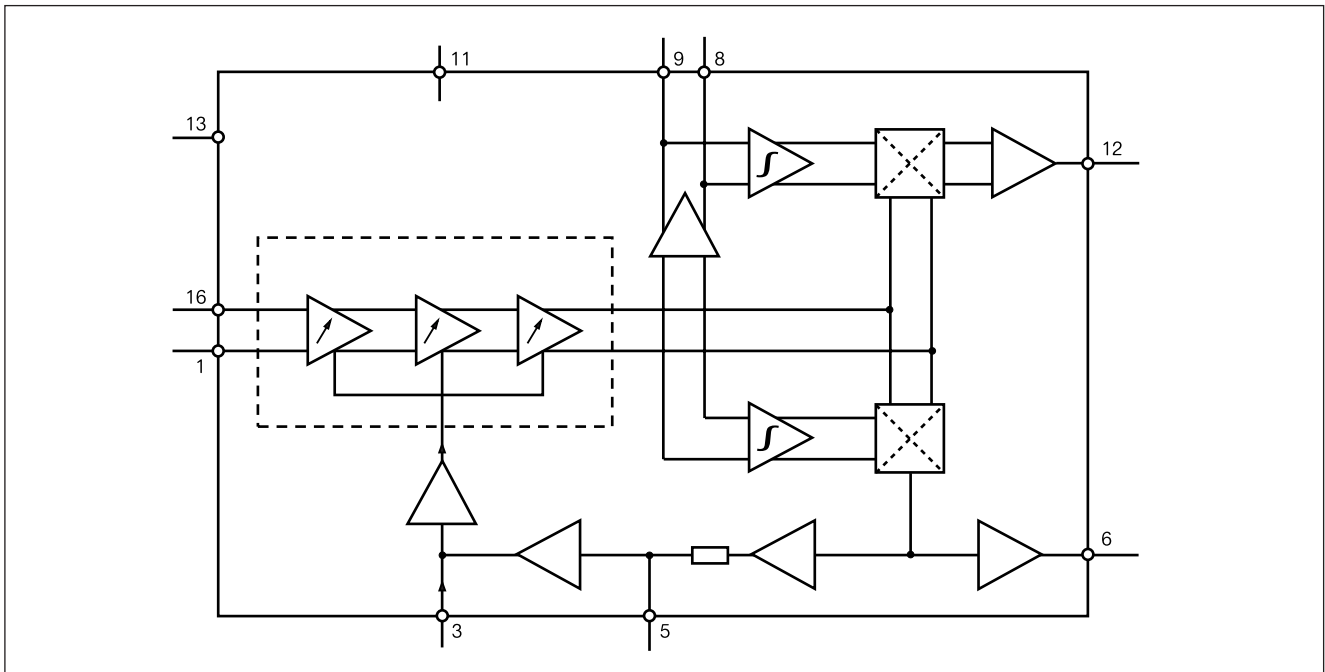

### (4) Pin Description

PIN	DESCRIPTION
1, 16	IF input
3	IF AGC time constant
8, 9	Tuned circuit
11	Supply voltage
12	Sound-IF-output
13	Ground
2,4,7,10	not be connected
14,15	not be connected
5	Average capacitor
6	AF output

# GMS30112-R098 (4-bit Single Chip Microcomputer for Remote control)

## (1) General Description

The GMS30112-R098 is 4-bit single chip CMOS microcomputer.

## (2) Feature

- program memory : 1024 bytes
- data memory : 32 x 4 bits
- 43 types of instruction set
- 3 levels of subroutine nesting
- 1 bit output port for a large current (REMOUT signal)
- operating frequency : 300kHz - 1 MHz
- instruction cycle : 12.5 usec @ 480kHz
- CMOS process ( single 3.0 V power supply )
- stop mode (through internal instruction)
- released stop mode by key input (masked option)
- built in capacitor for ceramic oscillation circuit (masked option)
- built in a watch dog timer(WDT)
- low operating voltage (2.0 V to 4.0 V)

## (3) Block Diagram

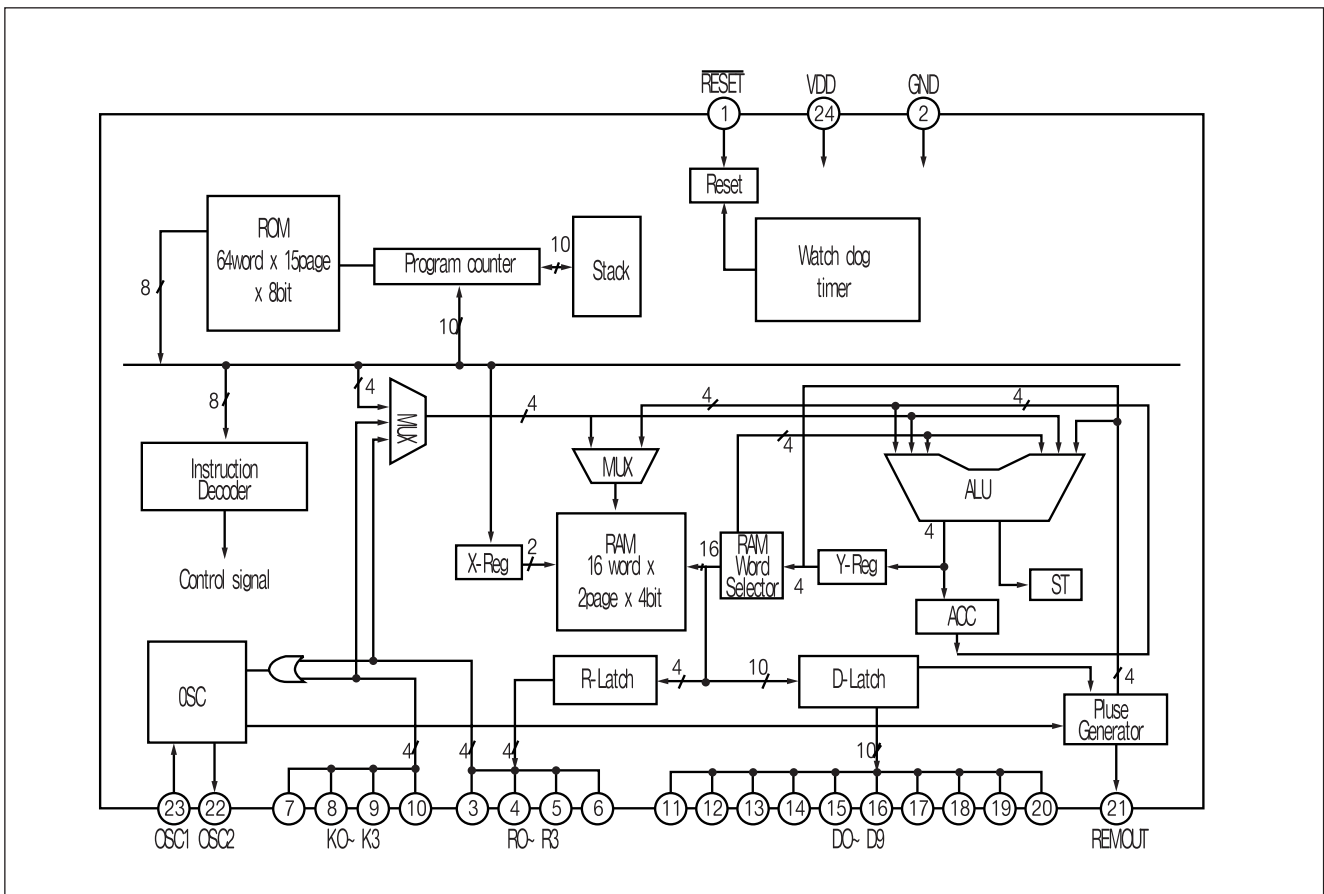

---

#### (4) Pin Description

PIN	SYMBOL	DESCRIPTION
1,2,3,4	K0,K1,K2,K3	4 bit input port with built in pull up resistor
5,6,7,8,9,10	D0,D1,D2,D3,D4,D5	10 bit output port which can be set or reset pin by pin independently. The output structure is N-channel open drain.
11	REMOUT	remote control signal output port which has high current driving capability
12	OSC 2	oscillator output
13	OSC 1	oscillator input
14	Vdd	2-4V power supply
15	RESET	reset signal input which is a low active
16	GND	ground
17,18,19,20	R0,R1,R2,R3	4 bit programmable I/O port

## ■ IC DC Voltage charts

\* **Input signal** ..... PAL/CH5-Video : 8 step colour bar (87% AM)

Audio : 1 KHz sinewave (60% FM)

\* **User's control condition** ..... Contrast, Brightness, Colour, Volume Controls-max.

\* **Line voltage** ..... AC 230V, 50Hz

\* **All the voltage in each point are measured with Multimeter.**

### 1. TDA 8375A (I501)

Pin No.	1	2	3	4	5	6	7	8	9	10
V(DC)	0	0	3.6	3.6	2.7	3.3	3.7	3.4	6.6	4

Pin No.	11	12	13	14	15	16	17	18	19	20
V(DC)	3.5	8	4	0	3.4	3.6	3.5	5.1	3.8	3.9

Pin No.	21	22	23	24	25	26	27	28	29	30
V(DC)	4	1.9	3.5	3.5	3.5	0.3	2.8	2.8	1.8	1.8

Pin No.	31	32	33	34	35	36	37	38	39	40
V(DC)	4	4	1.6	2.6	2.6	4.9	8	8	4	1.5

Pin No.	41	42	43	44	45	46	47	48	49	50
V(DC)	0.5	4.5	4	0	0.5	2.2	2.2	4	4	1.7

Pin No.	51	52	53	54	55	56
V(DC)	3.8	3.9	3	3	3.5	3.8

### 2. DW 5255S \* (I701)

Pin No.	1	2	3	4	5	6	7	8	9	10
V(DC)	0	5	3.4	3.6	5	5	5	5	0	0

Pin No.	11	12	13	14	15	16	17	18	19	20
V(DC)	5	2.6	2.6	5	5	4.1	0	5	5	0

Pin No.	21	22	23	24	25	26	27	28	29	30
V(DC)	5	5	5	0	2.6	2.6	2.6	5	1.5	1.5

Pin No.	31	32	33	34	35	36	37	38	39	40
V(DC)	0.5	2.5	5	0	0	5	5	2.7	2.8	3.2

Pin No.	41	42	43	44	45	46	47	48	49	50
V(DC)	0	0	4.7	5	0.4	1.3	0	0	0	0

Pin No.	51	52
V(DC)	0	0

### 3. TDA 4665 (I503)

Pin No.	1	2	3	4	5	6	7	8	9	10
V(DC)	5	0	0	0	0.6	0	0.3	0	5	0

Pin No.	11	12	13	14	15	16
V(DC)	2.9	2.9	0	1.3	0	1.3

### 4. TDA 4445B (I603)

Pin No.	1	2	3	4	5	6	7	8	9	10
V(DC)	4.5	0	2.5	0	4	4	0	4.7	4.7	0

Pin No.	11	12	13	14	15	16
V(DC)	12	5.3	0	0	0	4.5

### 5. TDA 4445B (I602)

Pin No.	1	2	3	4	5	6	7	8	9	10
V(DC)	4.5	0	2.6	0	4	4	0	4.8	4.8	0

Pin No.	11	12	13	14	15	16
V(DC)	12	3.7	0	0	0	4.5

---

**6. TDA 8395 (I502)**

Pin No.	1	2	3	4	5	6	7	8	9	10
V(DC)	1.6	1.2	8	0	0	0	3.3	4.3	1.7	1.7

Pin No.	11	12	13	14	15	16
V(DC)	0	0	0	0	0.5	3.4

**7. TDA 8138 (I802)**

Pin No.	1	2	3	4	5	6	7	8	9
V(DC)	12	4.5	3	4.5	0	5	0	12	5

**8. TDA 8351 (I301)**

Pin No.	1	2	3	4	5	6	7	8	9
V(DC)	2.3	2.3	16	8.3	0	4.6	8.3	0.6	7.1

**9. TDA 1519B (I601)**

Pin No.	1	2	3	4	5	6	7	8	9
V(DC)	1.9	0	6.4	6.4	0	6.5	13.3	12.7	1.9

**10. MSP 3410 (I602)**

Pin No.	1	2	3	4	5	6	7	8	9	10
V(DC)	0	0	0	0	0	0	4.9	0	3.6	3.4

Pin No.	11	12	13	14	15	16	17	18	19	20
V(DC)	2.5	2.5	2.5	2.5	2.5	4.9	3.8	4.9	0	3.8

Pin No.	21	22	23	24	25	26	27	28	29	30
V(DC)	0	2.5	0.5	5	0.1	0.1	0	1.5	1.7	0

Pin No.	31	32	33	34	35	36	37	38	39	40
V(DC)	3.8	3.8	3.8	3.8	0	3.8	3.8	7.1	8	6.2



---

Pin No.	41	42	43	44	45	46	47	48	49	50
V(DC)	0	3.7	3.8	3.8	3.8	3.8	3.8	0	3.8	3.8

Pin No.	51	52	53	54	55	56	57	58	59	60
V(DC)	0	3.8	3.8	2.7	4	0	5	1.5	1.5	0.1

Pin No.	61	62	63	64
V(DC)	0	2.5	2.5	0.1

## ■ Circuit Description

---

### Vision IF amplifier, AFC, video demodulator

The IF signal from the tuner is fed through a SAW filter to the differential IF input (pin 48 and 49).

The first IF stage consists of 3 AC-coupled amplifiers with a total gain control range of over 66 dB.

The reference carrier for the video demodulator is obtained by a PLL carrier regenerator

(eliminating notch filter compromises, as in reference tuned circuits for passive carrier regeneration).

Only an oscillator coil is needed (pin 3 and 4) that can be aligned via I2C-bus to the double IF frequency.

The AFC information is derived from the VCO control voltage of the IF-PLL and can be read via I2C-bus.

Bit AFB toggles when the picture carrier is exactly at the desired IF frequency (= half the aligned IF-PLL frequency).

AFA is active in a window around this point.

For fast search-tuning applications this window can be increased by a factor 3 (AFW bit).

### Tuner A.G.C.

The automatic gain control (A.G.C.) circuit operates on top sync level at negative modulated signals or on peak white level at positive modulation, selected by MOD bit.

The tuner A.G.C. is controlled via pin 54.

The tuner A.G.C. take over point (T.O.P.) can be set over a wide range: 0.8 mVrms .. 80 mVrms IF input signal amplitude.

The tuner AGC output may have to operate above Vcc of TDA8375A.

Therefore pin 54 is an open collector output, that can operate from 0.3 up to Vcc+ 1 Volt (at > 2 mA sink current)

### Source select switch

TDA8375A input switch can select one of the following sources ;

pin 13 front-end : CVBS I int

pin17 : CVBS 2 ext

pin 11.pinIO : Y (S-VHS), C (S-VHS)

Selected signal is available at the CVBS output pin 38, in case of Y/C input Y+C are added.

It drive teletext and the TDA8395 SECAM add-on.

For S-VHS applications, the Y,C input can be selected, independent of the CVBS source switch.

TDA8375A Y,C inputs are selected, while the source switch outputs CVBS I int or CVBS 2 ext on CVBS out.

### Horizontal synchronization and protection

The synchronization separator adapts its slicing level in the middle between top-sync and black level of the CVBS signal.

The separated synchronization pulses are fed to the first phase detector and to the coincidence detector.

The  $\phi$ -1 loop gain is determined by the components at pin 43 (C+RC).

The coincidence detector detects whether the horizontal line oscillator is synchronized to the incoming video.

The line oscillator is a VCO-type, running at twice the line frequency.

It is calibrated with the X-tal oscillator frequency of the colour decoder and has a maximum deviation of 2% of the nominal frequency, so no alignment is-needed.

Calibration is done at start up ( the TDA8375A must first know what colour X-tals are connected, bits XA and XB) and after synchronization loss ( $\phi$ -1 coincidence detector "Sync Locked" bit SL).

The second phase detector  $\phi$ -2 locks the phase of the horizontal driver pulses at output pin 40 to the horizontal flyback pulse at input pin 41 .

This compensates for the storage time of the horizontal deflection transistor.

The  $\phi$ - 2 loop filter (C) is externally connected to pin 42.

The horizontal phase can be given a static off set via I2C-but (HSH "horizontal shift")

A dynamic correction is possible by current feedback into the  $\phi$ - 2 loop filter capacitor.

To protect the horizontal deflection transistor, the horizontal drive is switched off immediately when a power

---

failure ( " Power-On Reset " bit POR ) is detected.

The power failure may have corrupted the contents of the internal data registers, so the TDA8375A should be started up again.

The TDA8375A has a separate supply input (pin 37) that only used as a clean supply voltage for the horizontal oscillator circuits.

## Vertical synchronization

The vertical sawtooth generator drives the vertical output.

It uses an external capacitor at pin 51 and a current reference resistor at pin 52.

The TDA8375A vertical drive has differential current outputs for DC-coupled vertical output stage, like the TDA8351 . At TDA8351 input pins 1 and 2 this current is converted into a drive voltage via a resistor.

## Geometry processing

With the TDA8375A is possible to implement automatic geometry alignment, because all parameters are adjusted via the I2C bus.

The deflection processor of the TDA8375A offers the following five controls;

- Horizontal shift
- Vertical slope.
- Vertical amplitude
- Vertical S-correction
- vertical shift

## Colour decoder

The colour decoder contains an alignment-free X-tal oscillator, a dual killer circuit and colour difference demodulators. Together with the TDA8395 SECAM add-on a multi standard PAL/SECAM/NTSC decoder can be built with automatic recognition.

Which standard can be decoded depends on the external Xtals used.

Two Xtal pins (34 and 36) are present so normally no external switching is required.

The I.C. must be told which X-tals are connected (bits XA and XB).

This is important, because the X-tal frequency of the colour decoder is also used to calibrate many internal circuit.

The burst phase detector locks the Xtal oscillator with the chroma burst signal.

The phase detector operates during the burst key period only, to prevent disturbance of the PLL by the chroma signal.

Two gain modes provide:

- Good catching range when the PLL is not Locked.
- Low ripple voltage and good noise immunity once the PLL has locked

The killer circuit switches-off the R-Y and B-Y demodulators at very low input signal conditions (chroma burst amplitude).

A hysteresis prevents on/off switching at low, noisy signals.

Color standard	pin34	pin35	XA	XB
PAL4.43/SECAM + NTSC-4.43	none	4.43	1	0
PAL4.43/SECAM + NTSC-M	3.58	4.43	1	1

## Integrated video filters

The TDA8375A has alignment-free internal luminance delay, chroma bandpass and chroma trap.

They are implemented as gyrator circuits tuned by tracking to the frequency of the chroma Xtal oscillator.

The chroma trap in the Y signal path is by-passed when Y/C input is selected (S-VHS ).

For SECAM an extra luminance delay is build-in, for correct delay of the luminance signal.

---

## RGB output and black current stabilization

The colour difference signals (R-Y, B-Y) are matrixed with the luminance signal (Y) to obtain the RGBout output signals (pins 19, 20, 21).

In the TDA8375A the matrix type automatically adapts to the decoded standard (NTSC,PAL) .

Linear amplifiers are used to interface external RGB in signals (pins 23,24,25) from the SCART connector.

These signals overrule the internal RGB signals when the data insertion pin 26 (FBI) is switched to a level between 1.0V and 3.0V.

The contrast and brightness control and the peak white limiter operate on both internal and external RGB signals R,G and B each have their own, independent gain control to compensate for the difference in phosphor efficiencies of the picture tube: so called "white point" adjustment.

The nominal amplitude is about 2V black to white, at nominal input signals and control settings.

TDA8375A has a black current stabilization loop, that automatically adjust the black level to the cut-off voltage of the picture tubes three gun cathodes.

Since no current is flowing when the voltage the cathode is equal to the cut-off voltage of the tube, the loop stabilizes at a very small gun current.

This "black current" of the three guns is measured internally and compared with a reference current, to adjust the black level of RGBout.

The black level loop is active during 4 lines at the end of the vertical blanking.

In the first line the leakage current is measured (max. acceptable 100  $\mu$ A).

In the next three lines the black levels of the three guns are adjusted.

The nominal value of the 'black current' is 10  $\mu$ A.

The ratio of the 'black currents' for the 3 guns tracks automatically with the white point adjustment, so the back-ground colour is the same as the adjusted white point.

At switch-on of the TV receiver the black current stabilization circuit is not yet active and RGBout are blanked.

Before the first measurement pulses appear, 0.5 sec delay ensures that the vertical deflection is active, so the pulses will not be visible on the screen.

During the measuring lines RGBout will supply 4V pulses to the video output stages.

The TDA8375A waits until the black current feedback input (pin 18) exceeds 200  $\mu$ A, which indicates that the picture tube is warm-up.

Then the black current stabilization circuit is active.

After a waiting time of about 1.0 sec, the blanking of RGBout is released.

## Tuning

The AFC information of the TDA8375A is not available as an analogue voltage.

Automatic following (=frequency tracking, AFC) can be done via the I2C-bus by software.

The TDA8375A AFC window is typically 80 kHz wide.

This value is made higher than the 62.5 kHz tuning step, to prevent an automatic following loop from continuously adapting the tuning frequency..

With this AFC window ( $\pm 40$  kHz) the maximum tuning error is less than 62.5 kHz.

For high speed search-tuning-algorithms, the AFC window can be widened to 240 kHz via bit AFW.

## TDA8395 SECAM decoder

The TDA8395 is an alignment-free SECAM colour decoder, including a Cloche filter, demodulator and line identification circuit.

The Cloche filter is a gyrator-capacitor type.

Its frequency is calibrated in the vertical retrace period.

The calibration reference( pin 1 ) is obtained from the TDA8375A color X-tal oscillator (pin 33).

Pin 7 is a decoupling for the Cloche reference.

---

The voltage change at this pin due to leakage currents should be lower than 10 mV, during field scan, resulting in a capacitor of minimal 100 nF.

Pin 8 is the reference capacitor for the PLL.

The voltage variation during field scan at this pin should be lower than 2 mV, resulting in a capacitor of 220 nF.

The sandcastle input (pin 15) is connected to TDA8375A pin 41 and is used for generation of the blanking periods and provides clock information for the identification circuit.

The CVBS source select output (TDA8375A pin 38) supplies SECAM chroma to pin 16 of the TDA8395.

This is demodulated by a PLL demodulator, that uses the reference frequency at pin 1 and a bandgap reference to obtain the desired demodulation characteristic.

If the digital line identification in the TDA8395 detects SECAM, pin 1 will sink a current of 150  $\mu$ A out of TDA8375A SECAMref pin 33.

When the TDA8375A has not detected PAL or NTSC, it will respond by increasing the voltage at pin 33 from 1.5V to 5V. Now the TDA8375A color difference outputs pin 30 and 29 are made high-ohmic and the TDA8395 output pin 9 and 10 are switched on.

These outputs will be disconnected and high-ohmic when no SECAM is detected for two frame periods, the decoder will be initialized before trying again.

## SECAM-L and -L' application

For SECAM-L and L' the TDA8375A has to be switched to positive modulation via I2C-bus bit MOD.

SECAM-L' signals only occur in VHF band I and have their picture and sound carrier interchanged, compared to SECAM-L/PAL channels.

For SECAM-L' the IF picture carrier is situated at 34.5 MHz and the AM-sound carrier at 41MHz.

Therefore the IF-PLL reference has to be tuned away from 38.9 to 34.5 MHz.

This can be done via I2C-bus sub-address 15hex (IF-PLL).

The AM sound output is inserted at TDA8375A external audio input pin via the SCART plug.

When bit MOD selects positive modulation for SECAM-L/L', the TDA8375A automatically switches to external audio.

## Base band delay line TDA4665

TDA4665 is an integrated double baseband delay line of 64  $\mu$ S.

It couples to the TDA8375A and TDA8395 without any switches or alignments.

The TDA4665 consist of two main blocks:

- Two delay lines of 64  $\mu$ sec in switched capacitor technique
- Internal clock generation of 3 MHz, line locked to the sandcastle pulse

The TDA4665 operates according to the mode demanded by the colour transmission standard:

- For PAL it operates as geometric adder to satisfy the PAL demodulation requirements
- In NTSC mode it reduces cross-colour interference (comb-filtering)
- For SECAM it repeats the colour difference signal on consecutive horizontal scan lines.

A sandcastle pulse is connected to pin 5.

The top pulse voltage (should not exceed 5 V) can be directly coupled to the 5 V sandcastle output of the TDA8375A.

The R-Y and B-Y colour difference signals (from TDA8375A pins 30 and 29) are AC-coupled and clamped by the input stages at pins 16 and 14.

An internal 6 MHz Current controlled oscillator is line locked via a PLL to the sandcastle pulse at pin 5.

This clock drives the delay lines to obtain the required 64  $\mu$ sec.

Sample and hold low pass filters suppress the clock signal.

The original and the delayed signals are added, buffered and fed to the output pins 11 and 12.

These are AC-coupled to the R-Y and B-Y colour difference input pin 32 and 31 of TDA8375A.

---

The TDA4665 needs a 5 V supply voltage on pin 1 for the digital part and on pin 9 for the analog part.

### **TDA8351 vertical deflection.**

The TDA8351 is a vertical deflection circuit.

It can be used in 90 deflection systems with frame frequencies from 50 up to 120 Hz

With its bridge configuration the deflection output can be DC coupled with few external components.

Only a supply voltage for the scan and a second supply for the flyback are needed.

The TDA8351 can drive max.2A.

The vertical drive currents of TDA8375A pins 47 and 46 are connected to input pins 1 and 2 of the TDA8351.

The currents are converted into a voltage by a resistor between pins 1 and 2.

Pin2 is on a fixed DC level (internal bias voltage) and on pin 1 the drive voltage can be measured (typical 1.8 Vpp).

The drive voltage is amplified by 'A' and fed to two amplifiers 'B' and 'C', one is inverting and the other is a non inverting amplifier.

The outputs (pins 4 and 7) are connected to the series connection of the vertical deflection coil and feedback resistor .

The voltage across feedback resistor is fed via pin 9 to correction amplifier 'D', to obtain a deflection current which is proportional to the drive voltage.

The supply voltage for the TDA8351 is 16V at pin 3.

The flyback generator has a separate supply voltage of 45V on pin 6.

### **Horizontal deflection**

The circuit contains horizontal drive, line output transformer.

The horizontal driver pulses from the TDA8375A are amplified in the horizontal drive circuit, to get sufficient base-drive current for the high voltage switching transistor Q401.

During the horizontal scan period(  $\approx 52 \mu\text{s}$ ) Q401 will conduct, and a sawtooth current flows from +132V through the primary winding of the FBT to ground.

After this time Q401 is switched off and the energy stored in the FBT during the scan period will be transformed to the flyback capacitor CT.

This energy transfer will take place in a cosine shape because the primary of the FBT and CT form a resonant circuit.

The time the energy is transferred from FBT to CT. and back to the FBT, is called the flyback time and will take place in about  $12 \mu\text{s}$ .

The flyback peak voltage is about 9 times the scan voltage.

In series with the horizontal deflection coil there is a (damped) linearity corrector coil.

During the scan there is some loss in the resistance of the deflection coil.

In the first part of a line the linearity corrector stores some energy in a permanent magnet until it is saturated.

This improves the linearity of the horizontal scan speed.

The required S correction for the picture tube can be adjusted with the value of C408.

The beam current limiting information (BeamCurr) is derived from the foot of the H.V winding of the FBT.

This is connected via resistor to +8V.

As the beam current increase, the voltage on line BeamCurr decreases.

BeamCurr is damped by a integration filter before it is fed back to TDA8375A pin 22.

The TDA8375A will decrease the contrast (and eventually the brightness) to limit the average beam current.

### **EW drive**

The DC voltage on pin 45 is determined by the East-West driver stage input and may range from 1 to 8 volts.

To prevent distortion, the voltage must always be  $>1$  volt.

Because the DC voltage on pin 45 is equal to the minimal output voltage of the East-West driver stage (reached for  $i_{ew} = 0$ ), it is recommended to choose this level close to 1 volt for maximum range.

---

## Video amplifiers

Three TDA6106Q integrated video amplifiers drive cathode of the picture tube directly. They are protected against CRT flashover discharges and ESD (electro static discharge).

The three video amplifiers, have a beam current output I black, used by the TDA8375A black current loop to control the black level on the cathodes.

The outputs can be connected together because the black current 100p sequentially controls the black level for each cathode.

The amplification of the TDA6106Q is set by the resistors between pin 3 and 9 and between pin 3 (negative-input) and the TDA8375A output.

There are no alignment any more on the CPT panel, because of the automatic black current stabilization and because the white point adjustment can be done in the TDA8375A via I2C bus.

## Power Supply STR-S5707

### (1) VIN terminal, start-up circuit

A start-up circuit is to start and stop a operation of a control IC by detecting a voltage appearing at a VIN terminal (pin-9).

At start up of a power supply, when a voltage at the VIN terminal reaches to 8V (typical) by charging up C812 by the function of a start-up resistor, R802, a control circuit starts operating by the function of the start-up circuit.

After the control circuit starts its operation, power source is obtained by smoothing voltage appearing at winding of pin6-7 of T802.

### (2) Oscillator, F/B terminal voltage (Pin 7)

A oscillator generates pulse signals which turns a power transistor on and off by making use of charge and discharge of C1 and C2 incorporated in the Hybrid IC.

Constant voltage control of a switch-mode power supply is performed by changing both ON-time and OFF-time except when the load is light (ex. remote control stand-by mode of TVs).

The ON-time is controlled by changing a current charged by C1, which is as the result of that the detection winding of pin5-7 of T802, which detects a change of voltage in a secondary side, connected to the sensing terminal (Pin 7) has the current in accordance with an output signal from an output voltage detection circuit (an error amplifier) built in.

As an AC input voltage to the power supply gets the higher and a load current the smaller, the current flowing to the SENS terminal gets the larger, and the ON-time gets the shorter.

### (3) Function of INH terminal (Pin 6), control of OFF-time

Signal to the INH terminal is used as inputs to COMP.1 and COMP.2 inside of the control IC.

A threshold voltage of COMP.1, VTH1 is set at 0.75V (Ta=25°) and an input signal to a drive circuit becomes almost 0V (the power transistor is in OFF mode) when a voltage at the INH terminal reaches the VTH1.

A threshold voltage of COMP.2, VTH2, is set at 1.5V (Ta=25°).

When the INH terminal voltage reaches VTH2, an output from COMP.2 reverses (the power transistor is in on mode).

#### \* Quasi-resonant operation

By inputting the voltage of winding of pin6-7 of T802 which is synchronized with the energy discharge time of a secondary winding, pin14(or 15)-16 of T802, to the INH terminal through D805 and RC803, quasi-resonant operation can be achieved.

When the power transistor turns off and a voltage higher than VTH2 is applied to the INH terminal, C3 immediately discharges and then starts charging again.

Even after the discharge of energy of a secondary winding is completed, VINH does not immediately increases.

When it gets lower than VTH1, the transistor turns on.

---

\* Stand-By Mode

While being in remote control stand-by mode, the output voltage is kept on providing to the secondary side and the power transistor operates at A class mode.

**(4) Drive circuit**

The STR-S5707 applies the proportional drive system in order to minimize turn-on and saturation loss, and storage time.

**(5) OCP (over-current protection) function**

Over-current protection is performed pulse by pulse by directly detecting collector current of the power transistor. Detecting voltage is set to -1V below a reference point of GND (ground).

**(6) Latch circuit**

It is a circuit which sustains an output from the oscillator low and stops operation of the power supply when over-voltage protection (OVP) circuit and thermal shutdown (TSD) circuit are in operation.

As the sustaining current of the latch circuit is 500  $\mu$ A maximum when  $V_{IN}$  terminal voltage is 4V, the power supply circuit sustains the off state as long as current of 500  $\mu$ A minimum flows to  $V_{IN}$  terminal from a start-up resistor.

In order to prevent a malfunction to be caused by a noise and so on, delay time is provided by C1 incorporated in the IC and, therefore, the latch circuit operates when the OVP or TSD circuit is in operation, or an external signal input is provided for about 10  $\mu$ sec or longer.

In addition, even after the latch circuit start operating, the constant voltage regulator (Reg) circuit is in operation and the circuit current is at high level.

As a result,  $V_{IN}$  terminal voltage rapidly decreases.

When  $V_{IN}$  terminal voltage becomes lower than the shutdown voltage,  $V_{IN(OFF)}$  (4.9V typical), it starts increasing as the circuit current is below 500 $\mu$ A.

When it reaches the ON-state voltage,  $V_{IN(ON)}$  (8V typical),  $V_{IN}$  terminal voltage starts decreasing because the circuit current increases again.

When the latch circuit is on,  $V_{IN}$  terminal voltage increases and decreases within the range from 4.9V typical to 8V typical and is prevented from abnormally rising.

Cancellation of the latch is done by decreasing  $V_{IN}$  terminal voltage below 3.3V.

The power supply can be restarted after disconnecting an AC input to the power supply once.

**(7) Thermal shutdown circuit**

It is a circuit to trigger the latch circuit when the frame temperature of the IC exceeds 150 $^{\circ}$ C (typical).

Although the temperature is actually sensed at the control chip, it works against overheating of the power transistor as the power transistor and the control IC are mounted on the same lead frame.

**(8) Over-voltage protection circuit**

It is a circuit to trigger the latch circuit when  $V_{IN}$  terminal voltage exceeds 11V (typical).

Although it basically functions as protection of  $V_{IN}$  terminal against over-voltage, since  $V_{IN}$  terminal is usually supplied from the drive winding of the transformer and the voltage is proportional to the output voltage, it also functions against the over-voltage of secondary output which causes when the control circuit opens or in some other events.



## THE DIFFERENT PARTS FOR CRT (CP-775)

No	LOC.	NAME	28" (V/COLOR (2896ST, 2898ST))	28"(PHILIPS) (2896ST, 2898ST)	25"(PHILIPS) (2594ST)	25"(ORION) (25G1ST)	29"(ORION) (29G1ST)
1	C402	C MYLAR	1.6KV 7200PF	←	←	←	1.6KV 8200PF
			CMYH3C722J				CMYH3C822J
2	C404	C MYLAR	1.6KV 4700PF	←	←	←	1.6KV 8200PF
			CMYH3C472J				CMYH3C822J
3	C408	C MYLAR	400V 0.27MF	←	←	400V 0.33MF	400V 0.47MF
			CMYE2G274J			CMYE2G334J	CMYE2G474J
4	D406	DIODE	BYW95C	←	←	←	×
			DBYW95C - - -				
5	C409	C CERA	250V 47MF	←	←	←	×
			CEXF2E470V				
6	J802	WIRE COPPER	×	×	×	×	AWG22 1/0.65 TIN COATING
							85801065GY
7	R333	R C-FILM	1/4W 2K OHM	1/4W 3K OHM	←	←	←
			RD-4Z202J -	RD-4Z302J-			
8	R919	R FUSIBLE	1W 0.68	1W 3.3	←	←	←
			RF01Z688J -	RF01Z339J -			
9	V901	CRT	A66ECY13X611	A66EAK071X11	A59EAK071X11	A59KTB96X01 P38	A68KTB190X006 P38
			4859613360	4859622160	4859622260	4859608962	4859618060
10	ZDC10	COIL	DC-2701	←	DC-2501	DC-2500	DC-2901
		DEGAUSSING	58G0000103		58G719M096	58G0000092	58G0000094
11	L401	COIL	TRL-330	←	←	←	TRL-200D
		H-LINEARITY	58G0000025				58G0000039
12	P501A	CONN AS	YH025-06+YST025+	←	←	←	YH025-06+YST025+
			ULW=400				USW=500
13	ZCG10	CRT	2801H-1015-2P	←	2501H-1015-2P	←	2901H-1015-2P
		GROUND AS	48519A5510		48519A4010		48519A4210

## THE DIFFERENT PARTS FOR SYSTEM (CP-775)

No	LOC.	NAME	TF	TU	TK	TA
1	J701	WIRE COPPER	×	×	AWG22 1/0.65 TIN COATING 85801065GY	×
2	J702	WIRE COPPER	×	×	×	×
3	J703	WIRE COPPER	AWG221/0.65 TIN COATING 85801065GY	×	×	×
4	J704	WIRE COPPER	×	AWG22 1/0.65 TIN COATING 85801065GY	×	×
5	J705	WIRE DOPPER	×	×	×	AWG22 1/0.65 TIN COATING 85801065GY
6	J706	WIRE COPPER	×	×	×	×
7	SF01	FILTER SAW	G3962M 5PG3962M - -	G3962M 5PG3962M - -	G3962M 5PG3962M - -	G3962M 5PG3962M - -
8	SF02	FILTER SAW	G9251M 5PG9251M - -	K9260M 5PK9260M - -	K9260M 5PK9260M - -	G9251M 5PG9251M - -
9	SF03	FILTER SAW	×	×	×	L9461M 5PL9461M - -
10	Z502	FILTER CERA	MKT40MA100P 5PMKT40MA -	MKT40MA100P 5PMKT40MA -	×	MKT40MA100P 5PMKT40MA -
11	I502	IC	×	×	TDA8395 1TDA8395 - -	TDA8395 1TDA8395 - -
12	I604	IC	×	×	×	TDA4445B TDA4445B -
13	U100	TUNER VATACTOR	3303KHC 4859714430	DT2-IV17D 4859716130	3303KHC 4859714430	3303KHC 4859714430
14	P801	CORD POWER AS	CW4232+BL102NG +TUBE=2500 4859903110	CW3222/240V 5A +HOUS=2200 4859905110	KKP419C+BL102NG +TUBE+2100 4859902910	CW4232+BL102NG +TUBE=2500 4859903110
15	D601	DIODE	×	×	×	1S2186 D1S2186 - - -
16	D602	DIODE	×	×	×	1S2186 D1S2186 - - -

MECHANICAL EXPLODED VIEW

2896

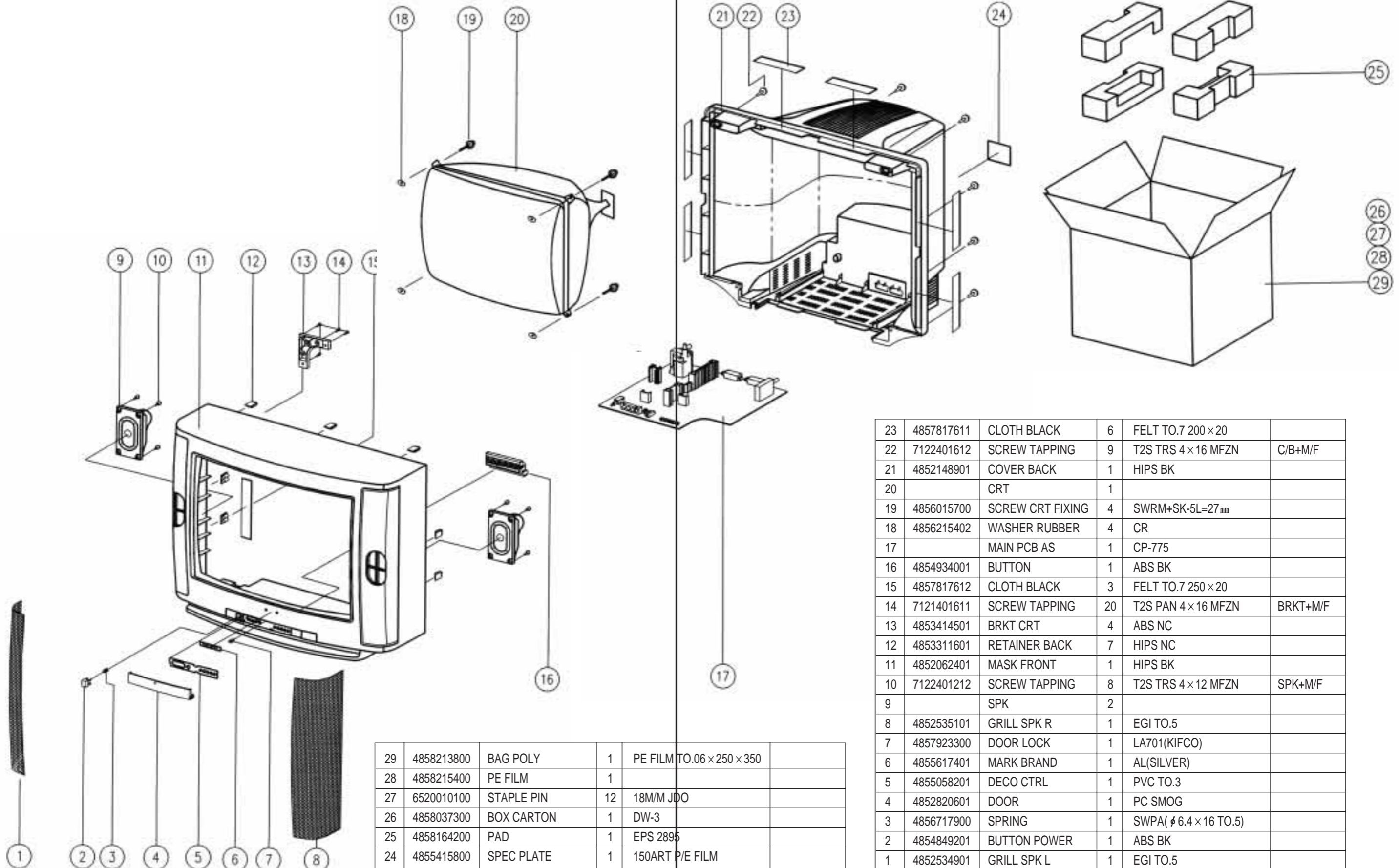

29	4858213800	BAG POLY	1	PE FILM TO.06 × 250 × 350	
28	4858215400	PE FILM	1		
27	6520010100	STAPLE PIN	12	18M/M JDO	
26	4858037300	BOX CARTON	1	DW-3	
25	4858164200	PAD	1	EPS 2895	
24	4855415800	SPEC PLATE	1	150ART P/E FILM	

23	4857817611	CLOTH BLACK	6	FELT TO.7 200 × 20	
22	7122401612	SCREW TAPPING	9	T2S TRS 4 × 16 MFZN	C/B+M/F
21	4852148901	COVER BACK	1	HIPS BK	
20		CRT	1		
19	4856015700	SCREW CRT FIXING	4	SWRM+SK-5L=27mm	
18	4856215402	WASHER RUBBER	4	CR	
17		MAIN PCB AS	1	CP-775	
16	4854934001	BUTTON	1	ABS BK	
15	4857817612	CLOTH BLACK	3	FELT TO.7 250 × 20	
14	7121401611	SCREW TAPPING	20	T2S PAN 4 × 16 MFZN	BRKT+M/F
13	4853414501	BRKT CRT	4	ABS NC	
12	4853311601	RETAINER BACK	7	HIPS NC	
11	4852062401	MASK FRONT	1	HIPS BK	
10	7122401212	SCREW TAPPING	8	T2S TRS 4 × 12 MFZN	SPK+M/F
9		SPK	2		
8	4852535101	GRILL SPK R	1	EGI TO.5	
7	4857923300	DOOR LOCK	1	LA701(KIFCO)	
6	4855617401	MARK BRAND	1	AL(SILVER)	
5	4855058201	DECO CTRL	1	PVC TO.3	
4	4852820601	DOOR	1	PC SMOG	
3	4856717900	SPRING	1	SWPA(φ 6.4 × 16 TO.5)	
2	4854849201	BUTTON POWER	1	ABS BK	
1	4852534901	GRILL SPK L	1	EGI TO.5	

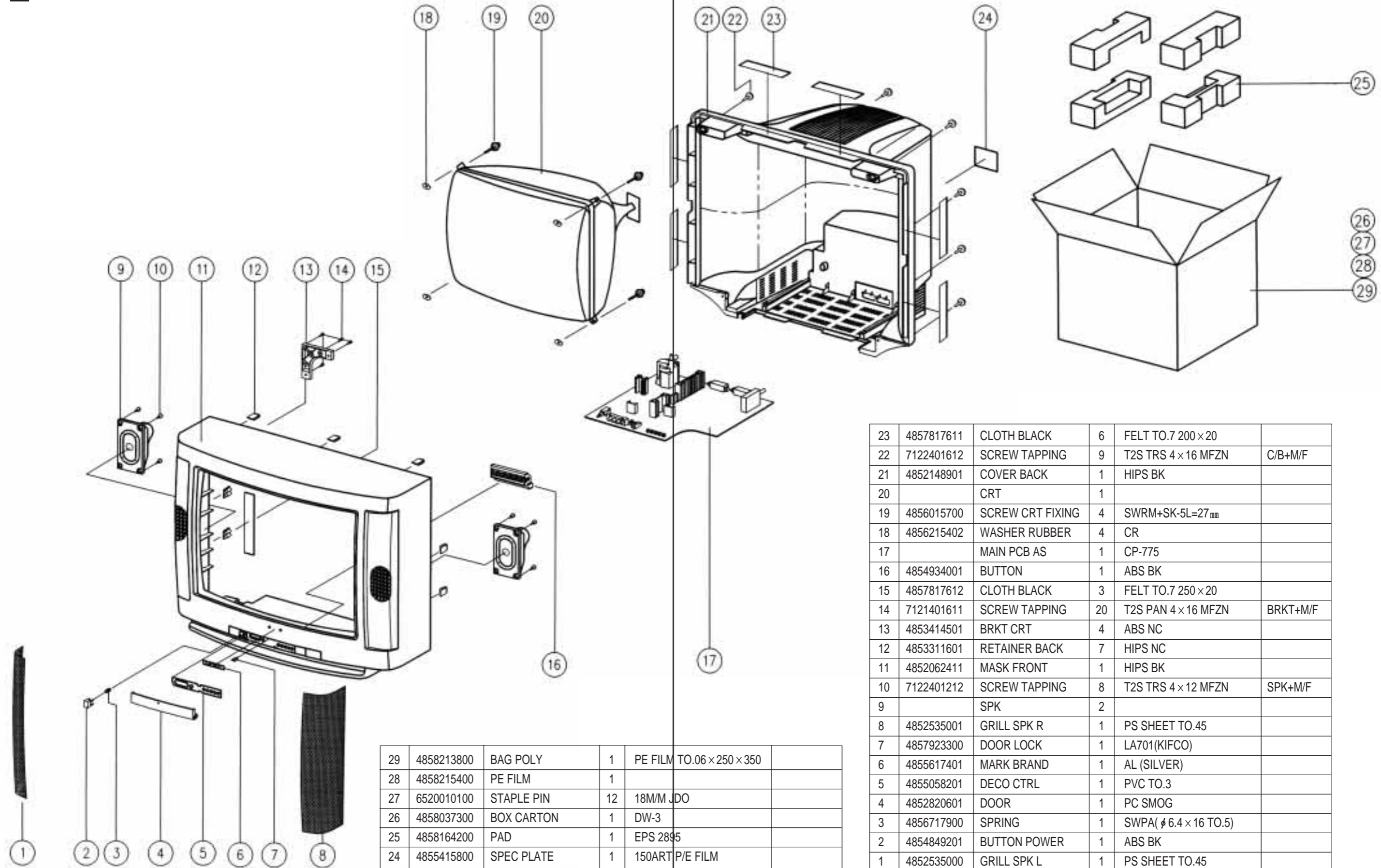

29	4858213800	BAG POLY	1	PE FILM	TO.06 × 250 × 350	
28	4858215400	PE FILM	1			
27	6520010100	STAPLE PIN	12	18M/M	JDO	
26	4858037300	BOX CARTON	1	DW-3		
25	4858164200	PAD	1	EPS 2895		
24	4855415800	SPEC PLATE	1	150ART	P/E FILM	

23	4857817611	CLOTH BLACK	6	FELT TO.7	200 × 20	
22	7122401612	SCREW TAPPING	9	T2S TRS	4 × 16 MFZN	C/B+M/F
21	4852148901	COVER BACK	1	HIPS BK		
20		CRT	1			
19	4856015700	SCREW CRT FIXING	4	SWRM+SK-5L=27mm		
18	4856215402	WASHER RUBBER	4	CR		
17		MAIN PCB AS	1	CP-775		
16	4854934001	BUTTON	1	ABS BK		
15	4857817612	CLOTH BLACK	3	FELT TO.7	250 × 20	
14	7121401611	SCREW TAPPING	20	T2S PAN	4 × 16 MFZN	BRKT+M/F
13	4853414501	BRKT CRT	4	ABS NC		
12	4853311601	RETAINER BACK	7	HIPS NC		
11	4852062411	MASK FRONT	1	HIPS BK		
10	7122401212	SCREW TAPPING	8	T2S TRS	4 × 12 MFZN	SPK+M/F
9		SPK	2			
8	4852535001	GRILL SPK R	1	PS SHEET	TO.45	
7	4857923300	DOOR LOCK	1	LA701(KIFCO)		
6	4855617401	MARK BRAND	1	AL (SILVER)		
5	4855058201	DECO CTRL	1	PVC	TO.3	
4	4852820601	DOOR	1	PC SMOG		
3	4856717900	SPRING	1	SWPA(φ 6.4 × 16	TO.5)	
2	4854849201	BUTTON POWER	1	ABS BK		
1	4852535000	GRILL SPK L	1	PS SHEET	TO.45	

25G1

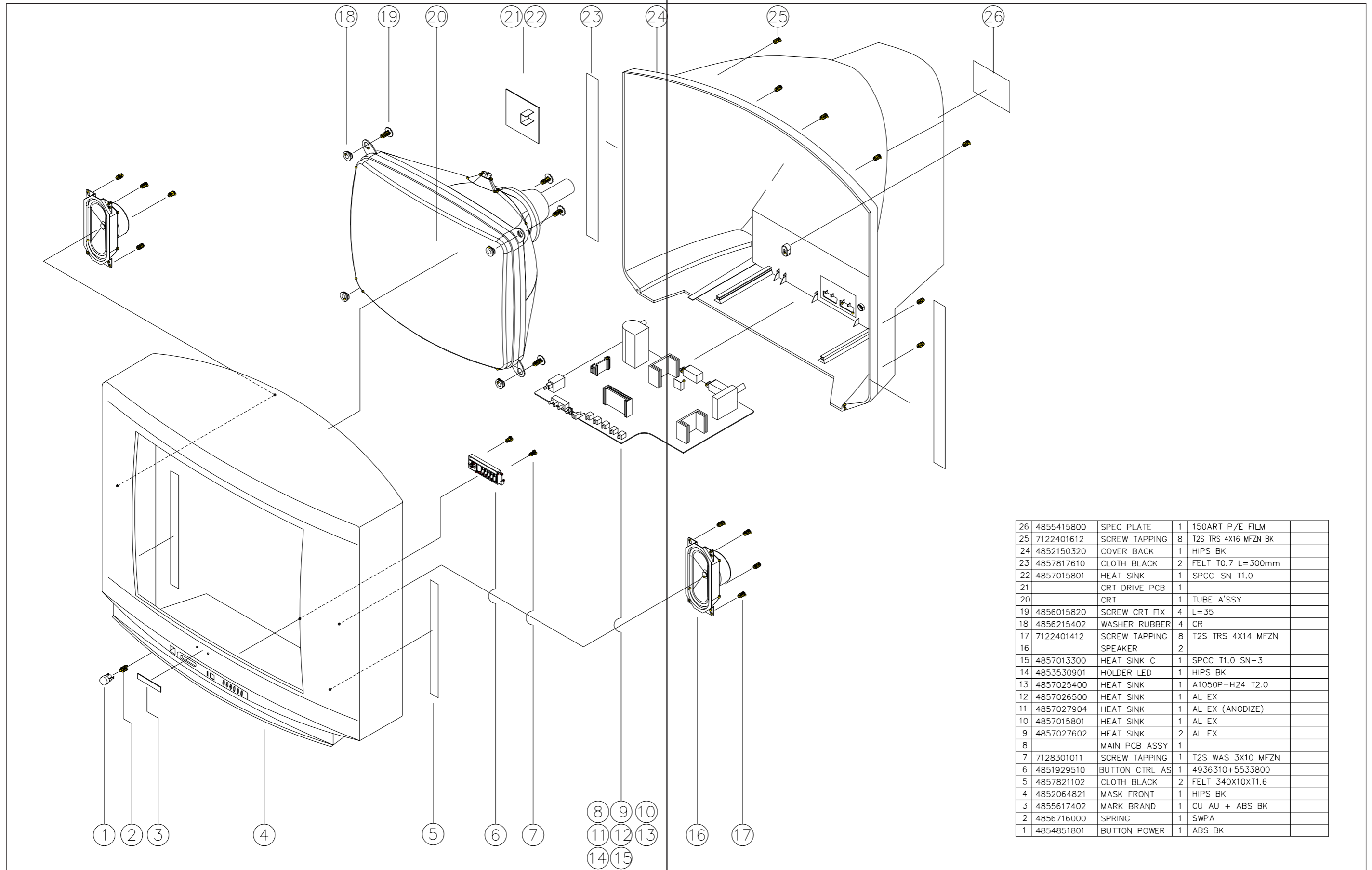

26	4855415800	SPEC PLATE	1	150ART P/E FILM	
25	7122401612	SCREW TAPPING	8	T2S TRS 4X16 MFZN BK	
24	4852150320	COVER BACK	1	HIPS BK	
23	4857817610	CLOTH BLACK	2	FELT T0.7 L=300mm	
22	4857015801	HEAT SINK	1	SPCC-SN T1.0	
21		CRT DRIVE PCB	1		
20		CRT	1	TUBE A'SSY	
19	4856015820	SCREW CRT FIX	4	L=35	
18	4856215402	WASHER RUBBER	4	CR	
17	7122401412	SCREW TAPPING	8	T2S TRS 4X14 MFZN	
16		SPEAKER	2		
15	4857013300	HEAT SINK C	1	SPCC T1.0 SN-3	
14	4853530901	HOLDER LED	1	HIPS BK	
13	4857025400	HEAT SINK	1	A1050P-H24 T2.0	
12	4857026500	HEAT SINK	1	AL EX	
11	4857027904	HEAT SINK	1	AL EX (ANODIZE)	
10	4857015801	HEAT SINK	1	AL EX	
9	4857027602	HEAT SINK	2	AL EX	
8		MAIN PCB ASSY	1		
7	7128301011	SCREW TAPPING	1	T2S WAS 3X10 MFZN	
6	4851929510	BUTTON CTRL AS	1	4936310+5533800	
5	4857821102	CLOTH BLACK	2	FELT 340X10XT1.6	
4	4852064821	MASK FRONT	1	HIPS BK	
3	4855617402	MARK BRAND	1	CU AU + ABS BK	
2	4856716000	SPRING	1	SWPA	
1	4854851801	BUTTON POWER	1	ABS BK	

29G1

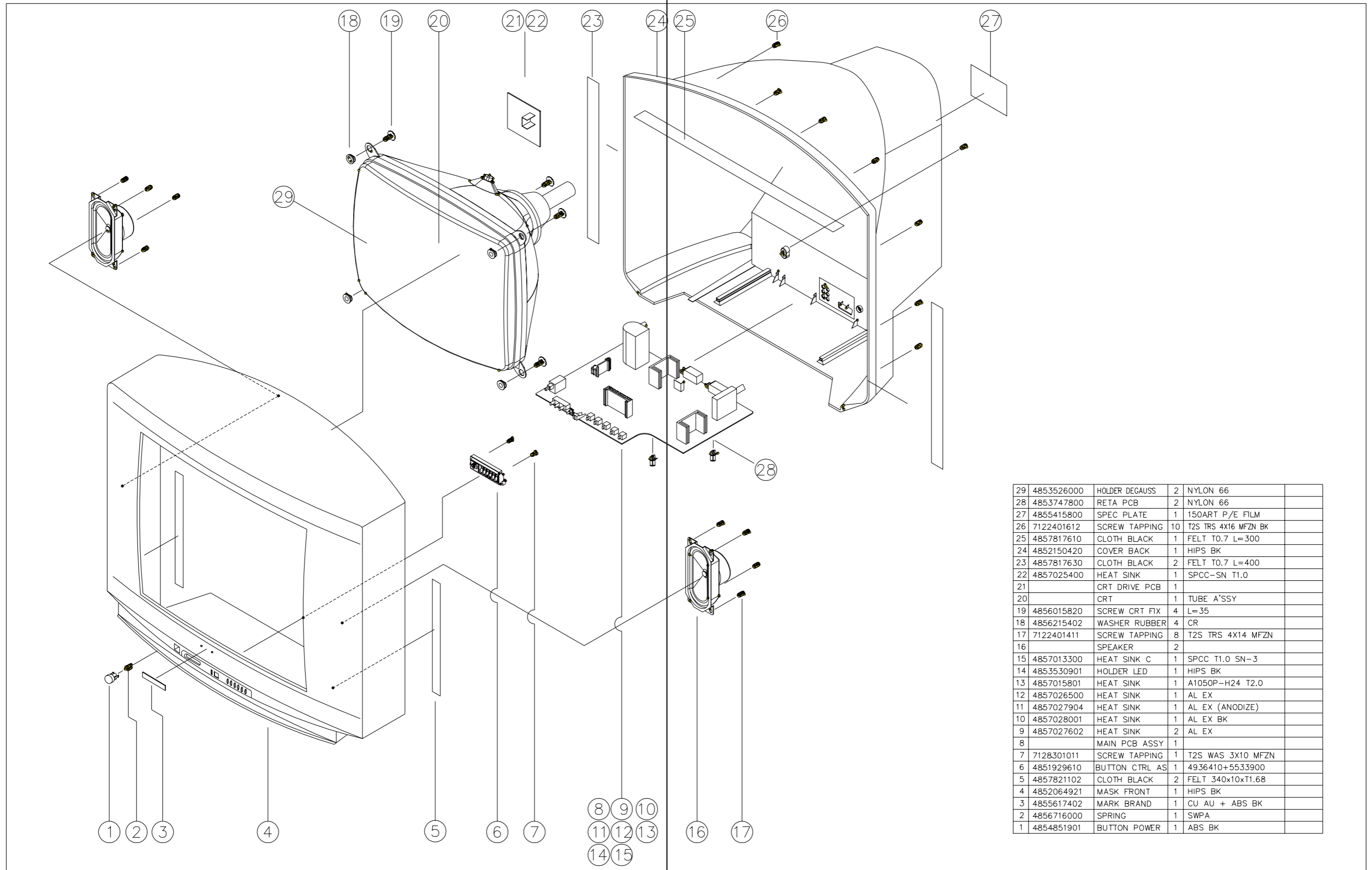

29	4853526000	HOLDER DEGAUSS	2	NYLON 66	
28	4853747800	RETA PCB	2	NYLON 66	
27	4855415800	SPEC PLATE	1	150ART P/E FILM	
26	7122401612	SCREW TAPPING	10	T2S TRS 4X16 MFZN BK	
25	4857817610	CLOTH BLACK	1	FELT TO.7 L=300	
24	4852150420	COVER BACK	1	HIPS BK	
23	4857817630	CLOTH BLACK	2	FELT TO.7 L=400	
22	4857025400	HEAT SINK	1	SPCC-SN T1.0	
21		CRT DRIVE PCB	1		
20		CRT	1	TUBE A'SSY	
19	4856015820	SCREW CRT FIX	4	L=35	
18	4856215402	WASHER RUBBER	4	CR	
17	7122401411	SCREW TAPPING	8	T2S TRS 4X14 MFZN	
16		SPEAKER	2		
15	4857013300	HEAT SINK C	1	SPCC T1.0 SN-3	
14	4853530901	HOLDER LED	1	HIPS BK	
13	4857015801	HEAT SINK	1	A1050P-H24 T2.0	
12	4857026500	HEAT SINK	1	AL EX	
11	4857027904	HEAT SINK	1	AL EX (ANODIZE)	
10	4857028001	HEAT SINK	1	AL EX BK	
9	4857027602	HEAT SINK	2	AL EX	
8		MAIN PCB ASSY	1		
7	7128301011	SCREW TAPPING	1	T2S WAS 3X10 MFZN	
6	4851929610	BUTTON CTRL AS	1	4936410+5533900	
5	4857821102	CLOTH BLACK	2	FELT 340x10xT1.68	
4	4852064921	MASK FRONT	1	HIPS BK	
3	4855617402	MARK BRAND	1	CU AU + ABS BK	
2	4856716000	SPRING	1	SWPA	
1	4854851901	BUTTON POWER	1	ABS BK	

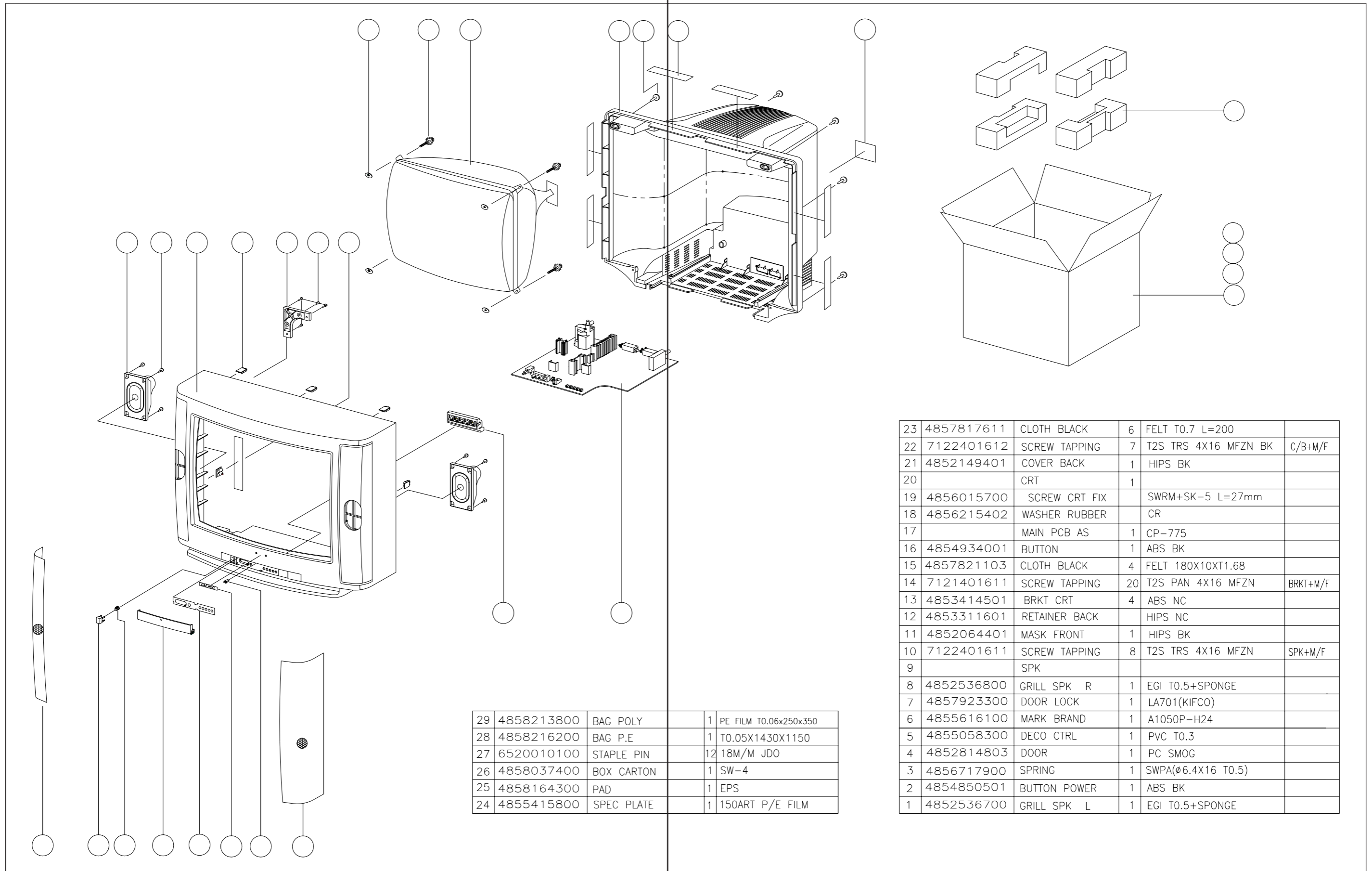

29	4858213800	BAG POLY	1	PE FILM T0.06x250x350
28	4858216200	BAG P.E	1	T0.05X1430X1150
27	6520010100	STAPLE PIN	12	18M/M JDO
26	4858037400	BOX CARTON	1	SW-4
25	4858164300	PAD	1	EPS
24	4855415800	SPEC PLATE	1	150ART P/E FILM

23	4857817611	CLOTH BLACK	6	FELT T0.7 L=200	
22	7122401612	SCREW TAPPING	7	T2S TRS 4X16 MFZN BK	C/B+M/F
21	4852149401	COVER BACK	1	HIPS BK	
20		CRT	1		
19	4856015700	SCREW CRT FIX		SWRM+SK-5 L=27mm	
18	4856215402	WASHER RUBBER		CR	
17		MAIN PCB AS	1	CP-775	
16	4854934001	BUTTON	1	ABS BK	
15	4857821103	CLOTH BLACK	4	FELT 180X10XT1.68	
14	7121401611	SCREW TAPPING	20	T2S PAN 4X16 MFZN	BRKT+M/F
13	4853414501	BRKT CRT	4	ABS NC	
12	4853311601	RETAINER BACK		HIPS NC	
11	4852064401	MASK FRONT	1	HIPS BK	
10	7122401611	SCREW TAPPING	8	T2S TRS 4X16 MFZN	SPK+M/F
9		SPK			
8	4852536800	GRILL SPK R	1	EGI T0.5+SPONGE	
7	4857923300	DOOR LOCK	1	LA701(KIFCO)	
6	4855616100	MARK BRAND	1	A1050P-H24	
5	4855058300	DECO CTRL	1	PVC T0.3	
4	4852814803	DOOR	1	PC SMOG	
3	4856717900	SPRING	1	SWPA(ø6.4X16 T0.5)	
2	4854850501	BUTTON POWER	1	ABS BK	
1	4852536700	GRILL SPK L	1	EGI T0.5+SPONGE	

28G2

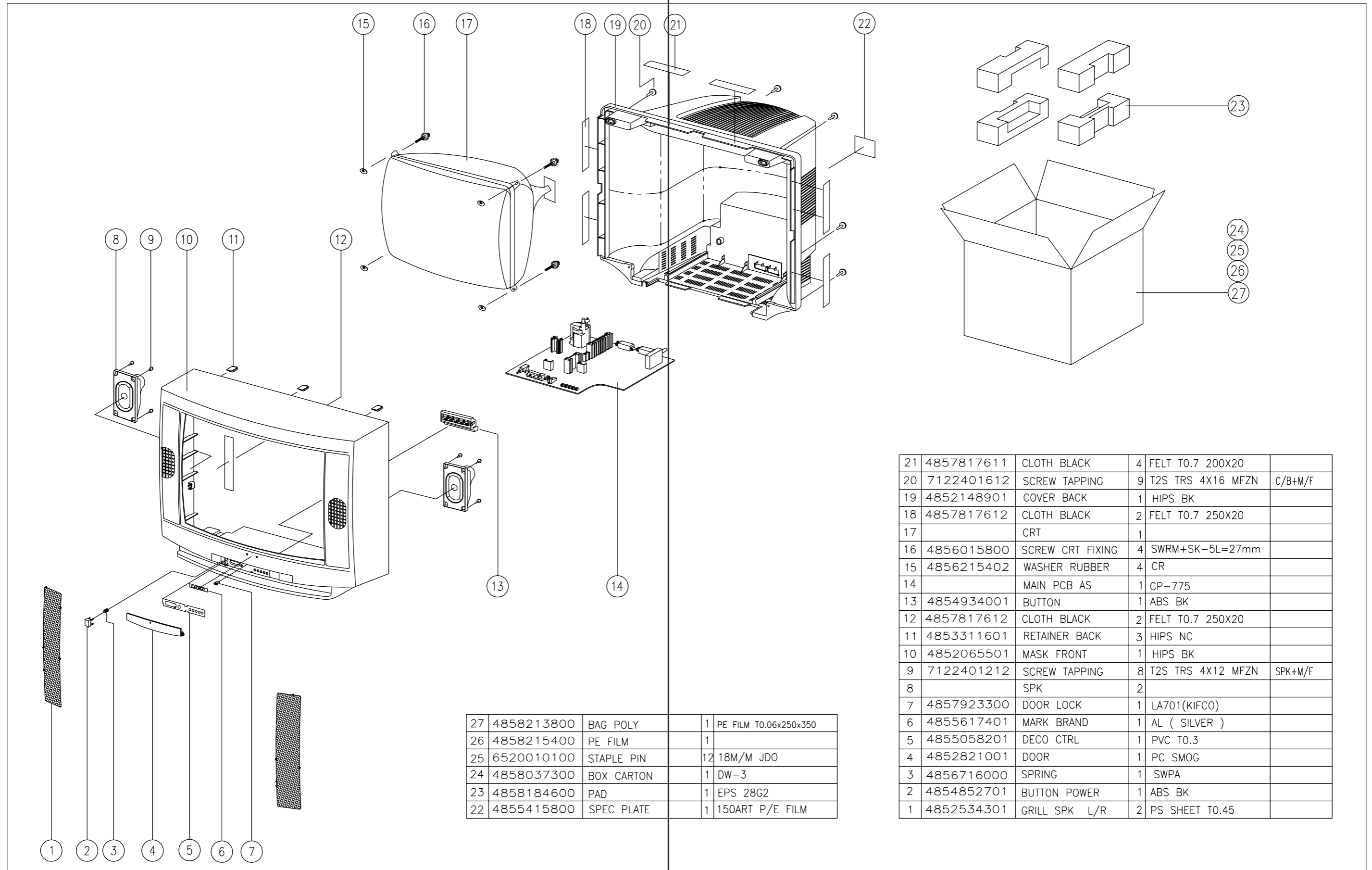

27	4858213800	BAG POLY	1	PE FILM T0.06x250x350
26	4858215400	PE FILM	1	
25	6520010100	STAPLE PIN	12	18M/M JDO
24	4858037300	BOX CARTON	1	DW-3
23	4858184600	PAD	1	EPS 28G2
22	4855415800	SPEC PLATE	1	150ART P/E FILM

21	4857817611	CLOTH BLACK	4	FELT T0.7 200X20	
20	7122401612	SCREW TAPPING	9	T2S TRS 4X16 MFZN	C/B+M/F
19	4852148901	COVER BACK	1	HIPS BK	
18	4857817612	CLOTH BLACK	2	FELT T0.7 250X20	
17		CRT	1		
16	4856015800	SCREW CRT FIXING	4	SWRM+SK-5L=27mm	
15	4856215402	WASHER RUBBER	4	CR	
14		MAIN PCB AS	1	CP-775	
13	4854934001	BUTTON	1	ABS BK	
12	4857817612	CLOTH BLACK	2	FELT T0.7 250X20	
11	4853311601	RETAINER BACK	3	HIPS NC	
10	4852065501	MASK FRONT	1	HIPS BK	
9	7122401212	SCREW TAPPING	8	T2S TRS 4X12 MFZN	SPK+M/F
8		SPK	2		
7	4857923300	DOOR LOCK	1	LA701(KIFCO)	
6	4855617401	MARK BRAND	1	AL ( SILVER )	
5	4855058201	DECO CTRL	1	PVC T0.3	
4	4852821001	DOOR	1	PC SMOG	
3	4856716000	SPRING	1	SWPA	
2	4854852701	BUTTON POWER	1	ABS BK	
1	4852534301	GRILL SPK L/R	2	PS SHEET T0.45	



# DTY-28G6

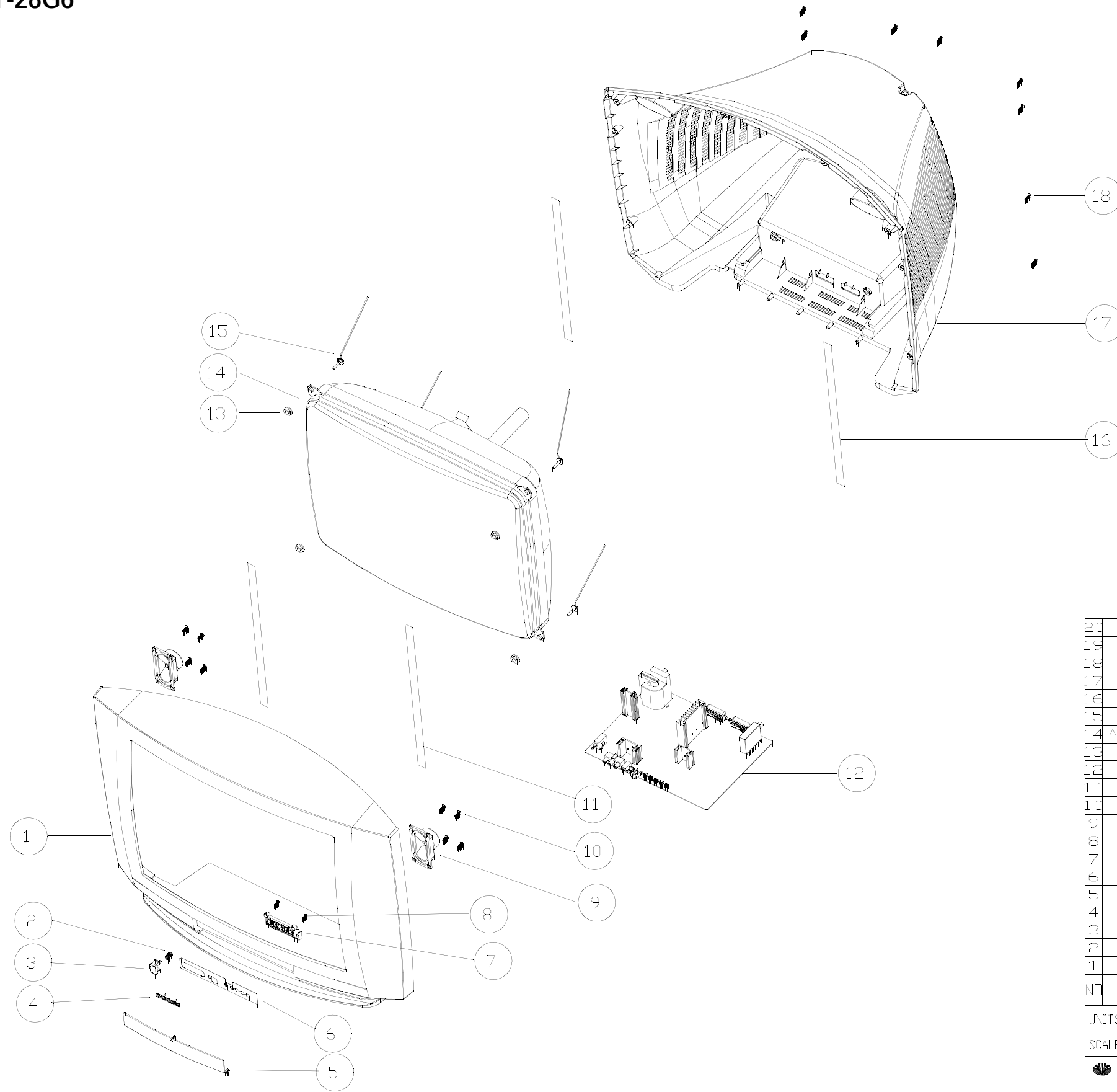

20						
19						
18	7122401612	SCREW TAPPING	10		SWRM BK	
17	4852151900	COVER BACK	1		HIPS BK	
16	4857817611	CLOTH BLACK	2		FELT T0.7 L=200	
15	4856015800	SCREW_CRT_FIX	4		SWRM+SK-5 BK	
14	A66ECY13X_26V	CRT A'ssy	1		GLASS	
13	4856215402	WASHER RUBBER	4		CR	
12		PCB A'ssy	1		cp-775	
11	4857818702	CLOTH BLACK	2		FELT T0.7 L=250 W=15	
10	7122401412	SCREW TAPPING	8		SWRM BK	
9		SPEAKER	2			
8	7121301212	SCREW TAPPING	2		SWRM BK	
7	4854939901	BUTTON_CTRL	1		ABS BK	
6	4855059001	DECO_CTRL	1		PS	
5	4852821501	DOOR	1		PC	
4	4855617400	MARK_BRAND	1		A1050P-H24	
3	4854854001	BUTTON_POWER	1		ABS	
2	4856716001	SPRING	1		SWPA	
1	4852067901	MASK_FRONT	1		HIPS BK	
NO	PART CODE	PART NAME	QTY		MATERIAL	REMARKS
UNITS	mm	Designed by	Checked by	Inspected by	Approved by	PART NAME
SCALE	N/S	Y.PULEE	N.M.WONG	K.G.OH	S.H.KIM	OUTLINE DRAWING <1/1>
		Daewoo Electronics CO.,LTD.	MODEL	DTY-28G6	3D	485009D1
		Mechanical Design Team, TV Research Center	REFERENCE		N	

DTY-28G7

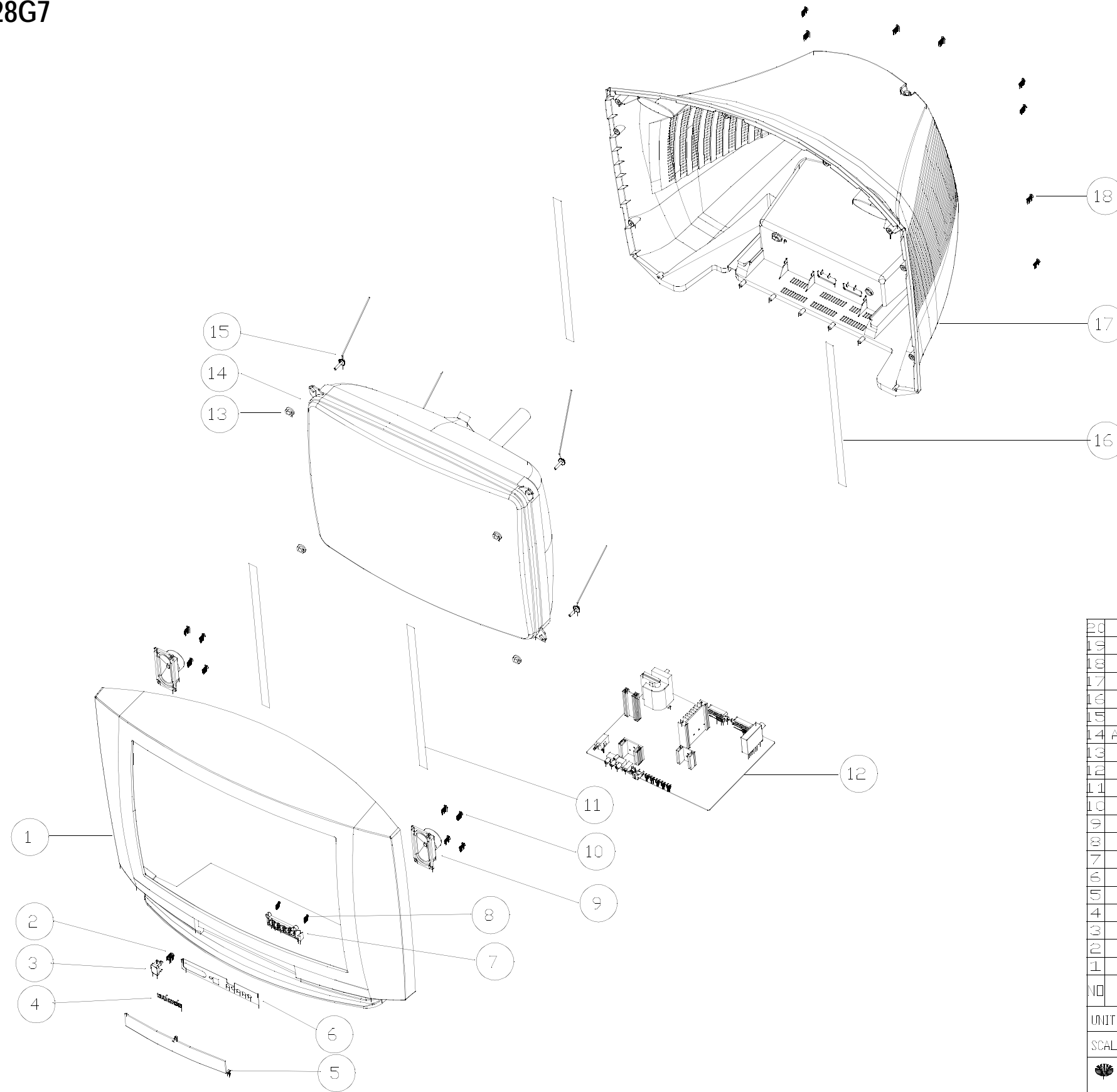

20					
19					
18	7122401612	SCREW TAPPING	10	SWRM BK	
17	4852151900	COVER BACK	1	HIPS BK	
16	4857817611	CLOTH BLACK	2	FELT T0.7 L=200	
15	4856015800	SCREW_CRT_FIX	4	SWRM+SK-5 BK	
14	A66ECY13X_26V	CRT A'ssy	1	GLASS	
13	4856215402	WASHER RUBBER	4	CR	
12		PCB A'ssy	1	cp-775	
11	4857818702	CLOTH BLACK	2	FELT T0.7 L=250 W=15	
10	7122401412	SCREW TAPPING	8	SWRM BK	
9		SPEAKER	2		
8	7121301212	SCREW TAPPING	2	SWRM BK	
7	4854939901	BUTTON_CTRL	1	ABS BK	
6	4855059001	DECO_CTRL	1	PS	
5	4852821701	DOOR	1	PC	
4	4855617400	MARK BRAND	1	A1050P-H24	
3	4854854101	BUTTON_POWER	1	ABS	
2	4856716001	SPRING	1	SWPA	
1	4852068001	MASK FRONT	1	HIPS BK	
NO	PART CODE	PART NAME	QTY	MATERIAL	REMARKS
UNITS	mm	Designed by	Checked by	Inspected by	approved by
SCALE	N/S	YH.LEE	NH.WONG	KC.OH	S.H.KIM
				PART NAME	
				OUTLINE DRAWING <1/1>	
		MODEL		DTY-28G7	D N
		REFERENCE		485009D3	

Daewoo Electronics CO.,LTD.  
Mechanical Design Team, TV Research Center

MODEL  
REFERENCE

DTY-28G7

485009D3

## ■ Electrical Parts List



Components marked with this symbol must only be replaced by a component having identical physical characteristics.

LOC.	PART-CODE	PART-NAME	PART-DESCRIPTION	REMARK
ZAC10	PSACPW0069	ACCESSORY AS	DTY-2896TAF	
M821	4858211400	POLY BAG	P.E FILM T0.03X600X550	
10	47P7500001	BATTERY	AAM 1.5V	
10000	48586A1617	MANUAL INSTRUCTION	ALL	
ZBC10	PSBCSH0031	COVER BACK AS	DTY-2896TF	
M211	4852148901	COVER BACK	HIPS BK	
M541	4855415800	SPEC PLATE	150ART P/E FILM (C/TV)	
M781	4857817611	CLOTH BLACK	FELT T0.7 L=200	
M782	4857817610	CLOTH BLACK	FELT T0.7 L=300	
ZCA10	PSCACA0069	CABINET AS	DTY-2896TAF	
M211A	7122401612	SCREW TAPPING	T2S TRS 4X16 MFZN BK	
M251	4852534901	GRILL SPKR L	EGI T0.5	
M252	4852535101	GRILL SPKR R	EGI T0.5	
M281	4852820601	DOOR	PC SMOG	
M352	97P4602700	CLAMP CORD	NYLON 66 BLK 5280N	
M481	4854849201	BUTTON POWER	ABS BK	
M481A	4856717900	SPRING	SWPA	
M491	4854934001	BUTTON	ABS BK	
M501	4855058201	DECO CTRL	PVC T0.3	
M561	4855617401	MARK BRAND	AL (SILVER)	
M681	4856812001	TIE CABLE	NYLON66 DA100	
M783	4857817612	CLOTH BLACK	FELT T0.7 L=250	
M791	4857923300	DOOR LOCK	LA701(KIFCO)	
P405	4850706S10	CONN AS	35135-06+HS30052+ULW=500	
SP01B	7122401212	SCREW TAPPING	T2S TRS 4X12 MFZN BLACK	
SP01C	7122401212	SCREW TAPPING	T2S TRS 4X12 MFZN BLACK	
V901	4859622160	CRT	A66EAK071X11	△
V901A	4856215402	WASHER RUBBER	CR	
V901B	4856015700	SCREW CRT FIX	SWRM+SK5 L=27	
ZFM10	PSFMSJ0031	MASK FRONT AS	DTY-2896TF	
M201	4852062401	MASK FRONT	HIPS BK	
M331	4853311601	RETAINER BACK	HIPS NC	
M341	4853414501	BRKT CRT	ABS NC	
M341A	7121401611	SCREW TAPPING	T2S PAN 4X16 MFZN	
ZMP10	PSMPMS0069	PCB MAIN MANUAL AS	DTY-2896TAF	
10	2193102005	SOLDER BAR	SN:PB=63:47 S63S-1320	
20	2193011101	SOLDER WIRE	RS 60-1.2 1.6A	
30	2291050615	FLUX SOLDER	DF-2012U	

LOC.	PART-CODE	PART-NAME	PART-DESCRIPTION	REMARK
40	2291050301	FLUX SOLVENT	IM-1000	
60	2224050026	BOND SILICON	RTV 122 CARTRIDGE	
90	2291051001	FLUX KILLER	KFT-7	
C302	CEYD1H689W	C ELECTRO	50V RHD 6.8MF (16X35.5)	△
C402	CMYH3C722J	C MYLAR	1.6KV BUP 7200PF J	△
C404	CMYH3C472J	C MYLAR	1.6KV BUP 4700PF J	△
C408	CMYE2G274J	C MYLAR	400V PU 0.27MF J	
C417	CMYB2G472J	C MYLAR	100V 0.1MF J (TP)	
C666	CEXF1E102V	C ELECTRO	25V RSS 1000MF (13X20) TP	
C801	CL1JB3474M	C LINE ACROSS	AC250V 0.47MF U/C/SNDFIS	△
C805	CEYN2G181P	C ELECTRO	400V LHS 180MF (25X35)	△
C821	CH1FFE472M	C CERA AC	4.0KV 4700PF M KD AC250V	△
C965	CCYB3D102K	C CERA	2KV B 1000PF K	△
D403	DBY228—	DIODE	BY228 (TAPPING)	△
D404	DBYW95C—	DIODE	BYW95C (TAPPING)	△
D406	DBYW95C—	DIODE	BYW95C (TAPPING)	△
D707	DKLR114L—	LED	KLR114L	
D809	DBYW95C—	DIODE	BYW95C (TAPPING)	
D810	DBYW95C—	DIODE	BYW95C (TAPPING)	
D812	DBYW95C—	DIODE	BYW95C (TAPPING)	
F801	5FSCB4022R	FUSE CERA	SEMKO F4AH 4A 250V MF51	△
G971	4SG0D00103	SPARK GAP	S-23 900V-1.5KV	
G972	4SG0D00103	SPARK GAP	S-23 900V-1.5KV	
G973	4SG0D00103	SPARK GAP	S-23 900V-1.5KV	
HP01	4859102130	JACK EARPHONE	YSC-1537	
I301	1TDA8351—	IC VERTICAL	TDA8351	
I301A	4857024403	HEAT SINK	AL EX	
I301B	7174301011	SCREW TAPPTITE	TT2 RND 3X10 MFZN	
I501	1TDA8375A-	IC VCD	TDA8375A	
I502	1TDA8395—	IC	TDA8395	
I503	1TDA4665V4	IC DELAY	TDA4665/V4	
I601	1TDA1519B-	IC AMP	TDA1519B	
I601A	4857026401	HEAT SINK	AL EX (BK)	
I601B	7174300811	SCREW TAPPTITE	TT2 RND 3X8 MFZN	
I601C	4856815900	CLAMP WIRE	EGI T0.4+PVC COATING	
I601D	7128261011	SCREW TAPPING	T2S WAS 2.6X10 MFZN	
I602	1MSP3410D-	IC AUDIO	MSP3410D	
I603	1TDA4445B-	IC	TDA4445B	
I604	1TDA4445B-	IC	TDA4445B	
I700	1UPC574J—	IC	UPC574J	
I701	1DW5255S1-	IC MICOM	DW5255S1	
I702	124LC08B—	IC MEMORY	24LC08B	

LOC.	PART-CODE	PART-NAME	PART-DESCRIPTION	REMARK
I703	1TFMW5380-	IC PREAMP	TFMW5380	
I801	1STRS5707-	IC POWER	STR-S5707	△
I801A	4857025403	HEAT SINK	AL050P-H24 T=2	
I801B	7174301011	SCREW TAPPTITE	TT2 RND 3X10 MFZN	
I802	1TDA8138—	IC REGULATOR	TDA8138	
I802A	4857025401	HEAT SINK	A1050P-H24 T2	
I802B	7174300811	SCREW TAPPTITE	TT2 RND 3X8 MFZN	
I803	1KA7808—	IC REGULATOR	KA7808	
I901	1TDA6106Q-	IC AMP	TDA6106Q	
I902	1TDA6106Q-	IC AMP	TDA6106Q	
I903	1TDA6106Q-	IC AMP	TDA6106Q	
JPA01	4859200401	SOCKET RGB	SR-21A1 (ANGLE TYPE)	△
JPA02	4859200401	SOCKET RGB	SR-21A1 (ANGLE TYPE)	△
JPA03	4859108450	JACK PIN BOARD	YSC03P-4120-14A	
LF801	5PLF24A1—	FILTER LINE	LF-24A1	△
L103	58C9780027	COIL CHOKE	TRF-1201B (0.97 UH)	
L109	58M38R9006	COIL DET	TRF-1490	
L110	58E0000S37	COIL AFT	TRF-A001	
L401	58H0000025	COIL H-LINEARITY	TRL-330	
L402	58C7070085	COIL CHOKE	TLN-3062A	
L802	58C9430599	COIL CHOKE	AZ-9004Y(94MH)	
M351	4853530901	HOLDER LED	HIPS BK	
M721	4857235402	SHIELD CASE	SPTH-C T0.25	
PWC1	4859903110	CORD POWER AS	CW4232+BL102NG+TUBE=2500	△
A000	4859903511	CORD POWER	CW4232 H03VVH2-F=2250	△
P401A	4850704S04	CONN AS	YH025-04+YST025+ULW=400	
P402	4859240120	CONN WAFER	YFW500-06	
P501A	4850706S02	CONN AS	YH025-06+YST025+ULW=400	
P801	4859242220	CONN WAFER	YFW800-02	
P802	4859242220	CONN WAFER	YFW800-02	
P903	4859238620	CONN WAFER	YPW500-02	
P904	4859275220	CONN WAFER	YF254-05R (ANGLE)	
Q401	T2SD1880—	TR	2SD1880	△
Q401A	4857024500	HEAT SINK	AL EX B/K	
Q401B	7174300811	SCREW TAPPTITE	TT2 RND 3X8 MFZN	
Q403	T2SB546K—	TR	2SB546-K	
Q403A	4857024902	HEAT SINK	AL EX	
Q403B	7174300811	SCREW TAPPTITE	TT2 RND 3X8 MFZN	
R406	RF-2Y479J-	R FUSIBLE	1/2 4.7 OHM J	
R801	DEC140M290	POSISTOR	ECPC140M290	△
R819	RX10B339JN	R CEMENT	10W 3.3 OHM J BENCH 4P	△
SCT1	4859302930	SOCKET CRT	ISHS-09S	△

LOC.	PART-CODE	PART-NAME	PART-DESCRIPTION	REMARK
SF01	5PG3962M—	FILTER SAW	G 3962-M	
SF02	5PG9251M—	FILTER SAW	G 9251-M	
SF03	5PL9461M—	FILTER SAW	L 9461-M	
SW801	5S40101143	SW PUSH	PS3-22SP (P.C.B)	△
T401	50D19A1—	TRANS DRIVE	TD-19A1	△
T402	50H0000181	FBT	1352.5008E	△
T802	50M0000101	TRANS SMPS	2094.0008C	△
U100	4859714430	TUNER VARACTOR	3303KHC-3X1289	
X501	5XE4R4336E	CRYSTAL QUARTZ	HC-49/U 4.433619MHZ 30PPM	
X502	5XE3R5795E	CRYSTAL QUARTZ	HC-49/U 3.579545MHZ 30PPM	
X601	5XE18R432E	CRYSTAL QUARTZ	HC-49/U 18.43200MHZ 30PPM	
X701	5XE18R000E	CRYSTAL QUARTZ	HC-49/U 18.000MHZ 30PPM	
Z502	5PMKT40MA-	FILTER CERA	MKT40MA100P	
ZMP10	PSMPJ20069	PCB CHIP MOUNT B AS	DTY-2896TAF	
CCA01	HCQK471JCA	C CHIP CERA	50V CH 470PF J 2012	
CCA02	HCQK331JCA	C CHIP CERA	50V CH 330PF J 2012	
CCA03	HCQK471JCA	C CHIP CERA	50V CH 470PF J 2012	
CCA04	HCQK331JCA	C CHIP CERA	50V CH 330PF J 2012	
CCA05	HCFK103ZCA	C CHIP CERA	50V Y5V 0.01MF Z 2012	
CCA06	HCFK103ZCA	C CHIP CERA	50V Y5V 0.01MF Z 2012	
CCA07	HCFK103ZCA	C CHIP CERA	50V Y5V 0.01MF Z 2012	
CCA08	HCFK103ZCA	C CHIP CERA	50V Y5V 0.01MF Z 2012	
CCA10	HCBK102KCA	C CHIP CERA	50V X7R 1000PF Z 2012	
CCA11	HCBK102KCA	C CHIP CERA	50V X7R 1000PF Z 2012	
CCA15	HCFK103ZCA	C CHIP CERA	50V Y5V 0.01MF Z 2012	
CCA16	HCBK102KCA	C CHIP CERA	50V X7R 1000PF K 2012	
CCA17	HCBK152KCA	C CHIP CERA	50V X7R 1500PF K 2012	
CCA18	HCBK102KCA	C CHIP CERA	50V X7R 1000PF K 2012	
CCA19	HCBK102KCA	C CHIP CERA	50V X7R 1000PF K 2012	
CCA20	HCBK102KCA	C CHIP CERA	50V X7R 1000PF K 2012	
CCA21	HCQK561JCA	C CHIP CERA	50V CH 560PF J 2012	
CCA22	HCQK561JCA	C CHIP CERA	50V CH 560PF J 2012	
CCA25	HCBK102KCA	C CHIP CERA	50V X7R 1000PF K 2012	
CCA26	HCFK103ZCA	C CHIP CERA	50V Y5V 0.01MF Z 2012	
CCA27	HCBK152KCA	C CHIP CERA	50V X7R 1500PF K 2012	
CCA31	HCFK103ZCA	C CHIP CERA	50V Y5V 0.01MF Z 2012	
CC101	HCQK220JCA	C CHIP CERA	50V CH 22PF J 2012	
CC102	HCBK102KCA	C CHIP CERA	50V X7R 1000PF K 2012	
CC103	HCBK102KCA	C CHIP CERA	50V X7R 1000PF K 2012	
CC104	HCBK102KCA	C CHIP CERA	50V X7R 1000PF K 2012	
CC105	HCBK102KCA	C CHIP CERA	50V X7R 1000PF K 2012	
CC106	HCBK102KCA	C CHIP CERA	50V X7R 1000PF K 2012	

LOC.	PART-CODE	PART-NAME	PART-DESCRIPTION	REMARK
CC111	HCBK473KCA	C CHIP CERA	50V X7R 0.047MF K 2012	
CC310	HCBK152KCA	C CHIP CERA	50V X7R 1500PF K 2012	
CC401	HCBK102KCA	C CHIP CERA	50V X7R 1000PF K 2012	
CC402	HCBK102KCA	C CHIP CERA	50V X7R 1000PF K 2012	
CC403	HCBK102KCA	C CHIP CERA	50V X7R 1000PF K 2012	
CC404	HCBK472KCA	C CHIP CERA	50V X7R 4700PF K 2012	
CC501	HCFK104ZCA	C CHIP CERA	50V Y5V 0.1MF Z 2012	
CC502	HCFK104ZCA	C CHIP CERA	50V Y5V 0.1MF Z 2012	
CC503	HCFK104ZCA	C CHIP CERA	50V Y5V 0.1MF Z 2012	
CC504	HCFK104ZCA	C CHIP CERA	50V Y5V 0.1MF Z 2012	
CC509	HCBK473KCA	C CHIP CERA	50V X7R 0.047MF K 2012	
CC510	HCBK472KCA	C CHIP CERA	50V X7R 4700PF K 2012	
CC511	HCFK104ZCA	C CHIP CERA	50V Y5V 0.1MF Z 2012	
CC512	HCBK223KCA	C CHIP CERA	50V X7R 0.022MF K 2012	
CC513	HCBK223KCA	C CHIP CERA	50V X7R 0.022MF K 2012	
CC514	HCBK223KCA	C CHIP CERA	50V X7R 0.022MF K 2012	
CC515	HCBK102KCA	C CHIP CERA	50V X7R 1000PF K 2012	
CC516	HCBK102KCA	C CHIP CERA	50V X7R 1000PF K 2012	
CC517	HCQK221JCA	C CHIP CERA	50V CH 220PF J 2012	
CC518	HCQK180JCA	C CHIP CERA	50V CH 18PF J 2012	
CC519	HCBK222KCA	C CHIP CERA	50V X7R 2200PF K 2012	
CC520	HCBK472KCA	C CHIP CERA	50V X7R 4700PF K 2012	
CC521	HCBK102KCA	C CHIP CERA	50V X7R 1000PF K 2012	
CC522	HCBK102KCA	C CHIP CERA	50V X7R 1000PF K 2012	
CC523	HCFK104ZCA	C CHIP CERA	50V Y5V 0.1MF Z 2012	
CC524	HCBK223KCA	C CHIP CERA	50V X7R 0.022MF K 2012	
CC526	HCBK152KCA	C CHIP CERA	50V X7R 1500PF K 2012	
CC527	HCFK104ZCA	C CHIP CERA	50V Y5V 0.1MF Z 2012	
CC528	HCQK181JCA	C CHIP CERA	50V CH 180PF J 2012	
CC529	HCQK100DCA	C CHIP CERA	50V CH 10PF D 2012	
CC530	HCBK102KCA	C CHIP CERA	50V X7R 1000PF K 2012	
CC531	HCFK104ZCA	C CHIP CERA	50V Y5V 0.1MF Z 2012	
CC532	HCBH224KCA	C CHIP CERA	25V X7R 0.22MF K 2012	
CC540	HCQK101JCA	C CHIP CERA	50V CH 100PF J 2012	
CC541	HCQK101JCA	C CHIP CERA	50V CH 100PF J 2012	
CC542	HCQK101JCA	C CHIP CERA	50V CH 100PF J 2012	
CC555	HCBK223KCA	C CHIP CERA	50V X7R 0.022MF K 2012	
CC601	HCQK391JCA	C CHIP CERA	50V CH 390PF J 2012	
CC602	HCQK391JCA	C CHIP CERA	50V CH 390PF J 2012	
CC603	HCBK102KCA	C CHIP CERA	50V X7R 1000PF K 2012	
CC604	HCFK104ZCA	C CHIP CERA	50V Y5V 0.1MF Z 2012	
CC605	HCQK471JCA	C CHIP CERA	50V CH 470PF J 2012	

LOC.	PART-CODE	PART-NAME	PART-DESCRIPTION	REMARK
CC606	HCQK471JCA	C CHIP CERA	50V CH 470PF J 2012	
CC607	HCFK104ZCA	C CHIP CERA	50V Y5V 0.1MF Z 2012	
CC608	HCBK223KCA	C CHIP CERA	50V X7R 0.022MF K 2012	
CC609	HCQK509DCA	C CHIP CERA	50V CH 5PF D 2012	
CC610	HCQK509DCA	C CHIP CERA	50V CH 5PF D 2012	
CC611	HCBK102KCA	C CHIP CERA	50V X7R 1000PF K 2012	
CC612	HCBK102KCA	C CHIP CERA	50V X7R 1000PF K 2012	
CC613	HCBK102KCA	C CHIP CERA	50V X7R 1000PF K 2012	
CC614	HCFK103ZCA	C CHIP CERA	50V Y5V 0.01MF Z 2012	
CC616	HCBK102KCA	C CHIP CERA	50V X7R 1000PF K 2012	
CC618	HCQK220JCA	C CHIP CERA	50V CH 22PF J 2012	
CC619	HCQK470JCA	C CHIP CERA	50V CH 47PF J 2012	
CC620	HCFK103ZCA	C CHIP CERA	50V Y5V 0.01MF Z 2012	
CC622	HCBK223KCA	C CHIP CERA	50V X7R 0.022MF K 2012	
CC623	HCFK104ZCA	C CHIP CERA	50V Y5V 0.1MF Z 2012	
CC624	HCBK223KCA	C CHIP CERA	50V X7R 0.022MF K 2012	
CC625	HCFK104ZCA	C CHIP CERA	50V Y5V 0.1MF Z 2012	
CC660	HCFK104ZCA	C CHIP CERA	50V Y5V 0.1MF Z 2012	
CC701	HCBK102KCA	C CHIP CERA	50V X7R 1000PF K 2012	
CC708	HCBK102KCA	C CHIP CERA	50V X7R 1000PF K 2012	
CC711	HCQK220JCA	C CHIP CERA	50V CH 22PF J 2012	
CC712	HCQK220JCA	C CHIP CERA	50V CH 22PF J 2012	
CC715	HCFK103ZCA	C CHIP CERA	50V Y5V 0.01MF Z 2012	
CC770	HCQK390JCA	C CHIP CERA	50V CH 39PF J 2012	
CC801	HCFK104ZCA	C CHIP CERA	50V Y5V 0.1MF Z 2012	
CC805	HCQK471JCA	C CHIP CERA	50V CH 470PF J 2012	
CC807	HCBK102KCA	C CHIP CERA	50V X7R 1000PF K 2012	
CC901	HCQK561JCA	C CHIP CERA	50V CH 560PF J 2012	
CC902	HCQK561JCA	C CHIP CERA	50V CH 560PF J 2012	
CC903	HCQK561JCA	C CHIP CERA	50V CH 560PF J 2012	
RCA02	HRFT473JCA	R CHIP	1/10 47K OHM J 2012	
RCA03	HRFT473JCA	R CHIP	1/10 47K OHM J 2012	
RCA10	HRFT750JCA	R CHIP	1/10 75 OHM J 2012	
RCA11	HRFT750JCA	R CHIP	1/10 75 OHM J 2012	
RCA14	HRFT750JCA	R CHIP	1/10 75 OHM J 2012	
RCA16	HRFT750JCA	R CHIP	1/10 75 OHM J 2012	
RCA17	HRFT750JCA	R CHIP	1/10 75 OHM J 2012	
RCA18	HRFT750JCA	R CHIP	1/10 75 OHM J 2012	
RCA19	HRFT750JCA	R CHIP	1/10 75 OHM J 2012	
RCA20	HRFT102JCA	R CHIP	1/10 1K OHM J 2012	
RCA21	HRFT102JCA	R CHIP	1/10 1K OHM J 2012	
RCA30	HRFT101JCA	R CHIP	1/10 100 OHM J 2012	



LOC.	PART-CODE	PART-NAME	PART-DESCRIPTION	REMARK
RC101	HRFT183JCA	R CHIP	1/10 18K OHM J 2012	
RC102	HRFT153JCA	R CHIP	1/10 15K OHM J 2012	
RC103	HRFT682JCA	R CHIP	1/10 6.8K OHM J 2012	
RC110	HRFT104JCA	R CHIP	1/10 100K OHM J 2012	
RC111	HRFT104JCA	R CHIP	1/10 100K OHM J 2012	
RC115	HRFT102JCA	R CHIP	1/10 1K OHM J 2012	
RC302	HRFT472JCA	R CHIP	1/10 4.7K OHM J 2012	
RC303	HRFT473JCA	R CHIP	1/10 47K OHM J 2012	
RC304	HRFT103JCA	R CHIP	1/10 10K OHM J 2012	
RC305	HRFT823JCA	R CHIP	1/10 82K OHM J 2012	
RC306	HRFT471JCA	R CHIP	1/10 470 OHM J 2012	
RC401	HRFT272JCA	R CHIP	1/10 2.7K OHM J 2012	
RC402	HRFT472JCA	R CHIP	1/10 4.7K OHM J 2012	
RC501	HRFT123JCA	R CHIP	1/10 12K OHM J 2012	
RC502	HRFT103JCA	R CHIP	1/10 10K OHM J 2012	
RC503	HRFT273JCA	R CHIP	1/10 27K OHM J 2012	
RC504	HRFT102JCA	R CHIP	1/10 1K OHM J 2012	
RC505	HRFT104JCA	R CHIP	1/10 100K OHM J 2012	
RC506	HRFT182JCA	R CHIP	1/10 1.8K OHM J 2012	
RC507	HRFT102JCA	R CHIP	1/10 1K OHM J 2012	
RC510	HRFT102JCA	R CHIP	1/10 1K OHM J 2012	
RC511	HRFT470JCA	R CHIP	1/10 47 OHM J 2012	
RC513	HRFT102JCA	R CHIP	1/10 1K OHM J 2012	
RC514	HRFT102JCA	R CHIP	1/10 1K OHM J 2012	
RC515	HRFT104JCA	R CHIP	1/10 100K OHM J 2012	
RC517	HRFT334JCA	R CHIP	1/10 330K OHM J 2012	
RC518	HRFT332JCA	R CHIP	1/10 3.3K OHM J 2012	
RC520	HRFT153JCA	R CHIP	1/10 15K OHM J 2012	
RC521	HRFT393JCA	R CHIP	1/10 39K OHM J 2012	
RC522	HRFT100JCA	R CHIP	1/10 10 OHM J 2012	
RC523	HRFT470JCA	R CHIP	1/10 47 OHM J 2012	
RC524	HRFT101JCA	R CHIP	1/10 100 OHM J 2012	
RC526	HRFT273JCA	R CHIP	1/10 27K OHM J 2012	
RC527	HRFT100JCA	R CHIP	1/10 10 OHM J 2012	
RC528	HRFT121JCA	R CHIP	1/10 120 OHM J 2012	
RC529	HRFT472JCA	R CHIP	1/10 4.7K OHM J 2012	
RC530	HRFT101JCA	R CHIP	1/10 100 OHM J 2012	
RC531	HRFT101JCA	R CHIP	1/10 100 OHM J 2012	
RC532	HRFT101JCA	R CHIP	1/10 100 OHM J 2012	
RC533	HRFT102JCA	R CHIP	1/10 1K OHM J 2012	
RC601	HRFT101JCA	R CHIP	1/10 100 OHM J 2012	
RC602	HRFT222JCA	R CHIP	1/10 2.2K OHM J 2012	

LOC.	PART-CODE	PART-NAME	PART-DESCRIPTION	REMARK
RC603	HRFT153JCA	R CHIP	1/10 15K OHM J 2012	
RC604	HRFT751JCA	R CHIP	1/10 750 OHM J 2012	
RC605	HRFT102JCA	R CHIP	1/10 1K OHM J 2012	
RC606	HRFT223JCA	R CHIP	1/10 22K OHM J 2012	
RC607	HRFT103JCA	R CHIP	1/10 10K OHM J 2012	
RC608	HRFT103JCA	R CHIP	1/10 10K OHM J 2012	
RC609	HRFT683JCA	R CHIP	1/10 68K OHM J 2012	
RC610	HRFT562JCA	R CHIP	1/10 5.6K OHM J 2012	
RC613	HRFT102JCA	R CHIP	1/10 1K OHM J 2012	
RC614	HRFT332JCA	R CHIP	1/10 3.3K OHM J 2012	
RC615	HRFT332JCA	R CHIP	1/10 3.3K OHM J 2012	
RC616	HRFT563JCA	R CHIP	1/10 56K OHM J 2012	
RC617	HRFT152JCA	R CHIP	1/10 1.5K OHM J 2012	
RC618	HRFT103JCA	R CHIP	1/10 10K OHM J 2012	
RC619	HRFT752JCA	R CHIP	1/10 5.1K OHM J 2012	
RC620	HRFT152JCA	R CHIP	1/10 7.5K OHM J 2012	
RC701	HRFT101JCA	R CHIP	1/10 100 OHM J 2012	
RC702	HRFT101JCA	R CHIP	1/10 100 OHM J 2012	
RC703	HRFT333JCA	R CHIP	1/10 33K OHM J 2012	
RC704	HRFT333JCA	R CHIP	1/10 33K OHM J 2012	
RC706	HRFT333JCA	R CHIP	1/10 33K OHM J 2012	
RC709	HRFT472JCA	R CHIP	1/10 4.7K OHM J 2012	
RC710	HRFT182JCA	R CHIP	1/10 1.8K OHM J 2012	
RC711	HRFT333JCA	R CHIP	1/10 33K OHM J 2012	
RC713	HRFT912JCA	R CHIP	1/10 9.1K OHM J 2012	
RC714	HRFT682JCA	R CHIP	1/10 6.8K OHM J 2012	
RC715	HRFT822JCA	R CHIP	1/10 8.2K OHM J 2012	
RC716	HRFT682JCA	R CHIP	1/10 6.8K OHM J 2012	
RC717	HRFT153JCA	R CHIP	1/10 15K OHM J 2012	
RC718	HRFT392JCA	R CHIP	1/10 3.9K OHM J 2012	
RC719	HRFT182JCA	R CHIP	1/10 1.8K OHM J 2012	
RC720	HRFT132JCA	R CHIP	1/10 1.3K OHM J 2012	
RC721	HRFT103JCA	R CHIP	1/10 10K OHM J 2012	
RC722	HRFT103JCA	R CHIP	1/10 10K OHM J 2012	
RC723	HRFT103JCA	R CHIP	1/10 10K OHM J 2012	
RC724	HRFT103JCA	R CHIP	1/10 10K OHM J 2012	
RC725	HRFT473JCA	R CHIP	1/10 47K OHM J 2012	
RC726	HRFT101JCA	R CHIP	1/10 100 OHM J 2012	
RC727	HRFT222JCA	R CHIP	1/10 2.2K OHM J 2012	
RC729	HRFT332JCA	R CHIP	1/10 3.3K OHM J 2012	
RC730	HRFT332JCA	R CHIP	1/10 3.3K OHM J 2012	
RC731	HRFT100JCA	R CHIP	1/10 10 OHM J 2012	

LOC.	PART-CODE	PART-NAME	PART-DESCRIPTION	REMARK
RC732	HRFT913JCA	R CHIP	1/10 91K OHM J 2012	
RC733	HRFT564JCA	R CHIP	1/10 560K OHM J 2012	
RC734	HRFT473JCA	R CHIP	1/10 47K OHM J 2012	
RC735	HRFT332JCA	R CHIP	1/10 3.3K OHM J 2012	
RC737	HRFT100JCA	R CHIP	1/10 10 OHM J 2012	
RC738	HRFT102JCA	R CHIP	1/10 1K OHM J 2012	
RC739	HRFT472JCA	R CHIP	1/10 4.7K OHM J 2012	
RC741	HRFT472JCA	R CHIP	1/10 4.7K OHM J 2012	
RC742	HRFT472JCA	R CHIP	1/10 4.7K OHM J 2012	
RC743	HRFT472JCA	R CHIP	1/10 4.7K OHM J 2012	
RC744	HRFT103JCA	R CHIP	1/10 10K OHM J 2012	
RC747	HRFT472JCA	R CHIP	1/10 4.7K OHM J 2012	
RC748	HRFT182JCA	R CHIP	1/10 1.8K OHM J 2012	
RC749	HRFT182JCA	R CHIP	1/10 1.8K OHM J 2012	
RC777	HRFT103JCA	R CHIP	1/10 10K OHM J 2012	
RC778	HRFT103JCA	R CHIP	1/10 10K OHM J 2012	
RC802	HRFT104JCA	R CHIP	1/10 100K OHM J 2012	
RC803	HRFT222JCA	R CHIP	1/10 2.2K OHM J 2012	
RC804	HRFT220JCA	R CHIP	1/10 22 OHM J 2012	
RC805	HRFT102JCA	R CHIP	1/10 1K OHM J 2012	
RC901	HRFT162JCA	R CHIP	1/10 1.6K OHM J 2012	
RC902	HRFT162JCA	R CHIP	1/10 1.6K OHM J 2012	
RC903	HRFT162JCA	R CHIP	1/10 1.6K OHM J 2012	
RC904	HRFT162JCA	R CHIP	1/10 1.6K OHM J 2012	
RC905	HRFT162JCA	R CHIP	1/10 1.6K OHM J 2012	
RC906	HRFT162JCA	R CHIP	1/10 1.6K OHM J 2012	
ZMP10	PSMPJ00069	PCB MAIN (RHU) AS	DTY-2896TAF	
C305	CEXF1E471V	C ELECTRO	25V RSS 470MF (10X16) TP	
C403	CEXF1E471V	C ELECTRO	25V RSS 470MF (10X16) TP	
C405	CMXE2G273J	C MYLAR	400V PU 0.027MF J (TP)	△
C409	CEXF2E470V	C ELECTRO	250V RSS 47MF (16X25) TP	
C413	CEXF2C470V	C ELECTRO	160V RSS 47MF (13X25) TP	
C415	CEXF2E100V	C ELECTRO	250V RSS 10MF (10X20) TP	
C416	CCXB3D681K	C CERA	2KV B 680PF K (TAPPING)	
C806	CCXB3D102K	C CERA	2KV B 1000PF K (TAPPING)	
C813	CEXF2C101V	C ELECTRO	160V RSS 100MF (16X25) TP	
C814	CEXF2C101V	C ELECTRO	160V RSS 100MF (16X25) TP	
C815	CEXF1E102V	C ELECTRO	25V RSS 1000MF (13X20) TP	
C820	CEXF1E222V	C ELECTRO	25V RSS 2200MF (16X25) TP	
C902	CEXF2E100V	C ELECTRO	250V RSS 10MF (10X20) TP	
C905	CEXF2E100V	C ELECTRO	250V RSS 10MF (10X20) TP	
ZMP10	PSMPJB0069	PCB MAIN M-10 AS	DTY-2896TAF	

LOC.	PART-CODE	PART-NAME	PART-DESCRIPTION	REMARK
P101	485923162S	CONN WAFER	YW025-03 (STICK)	
P401	485923172S	CONN WAFER	YW025-04 (STICK)	
P501	485923192S	CONN WAFER	YW025-06 (STICK)	
P601	485923172S	CONN WAFER	YW025-04 (STICK)	
P702	485923182S	CONN WAFER	YW025-OF(STICK)	
R407	RS02Z561JS	R M-OXIDE FILM	2W 560 OHM J SMALL	
R410	RS02Z223JS	R M-OXIDE FILM	2W 22K OHM J SMALL	
R415	RS02Z102JS	R M-OXIDE FILM	2W 1K OHM J SMALL	
R700	RS02Z912JS	R M-OXIDE FILM	2W 9.1K OHM J SMALL	
R701	RS02Z912JS	R M-OXIDE FILM	2W 9.1K OHM J SMALL	
R802	RS02Z473JS	R M-OXIDE FILM	2W 47K OHM J SMALL	
R803	RS02Z473JS	R M-OXIDE FILM	2W 47K OHM J SMALL	
R804	RF02Z338J-	R FUSIBLE	2W 0.33 OHM J (TAPPING)	△
R805	RS02Z300JS	R M-OXIDE FILM	2W 30 OHM J SMALL	
R812	RS02Z300JS	R M-OXIDE FILM	2W 30 OHM J SMALL	
R816	RS02Z300JS	R M-OXIDE FILM	2W 30 OHM J SMALL	
R820	RS02Z100JS	R M-OXIDE FILM	2W 10 OHM J SMALL	
R822	RF01Z228J-	R FUSIBLE	1W 0.22 OHM J (TAPPING)	
R916	RS02Z101JS	R M-OXIDE FILM	2W 100 OHM J SMALL	
R919	RF01Z339J-	R FUSIBLE	1W 3.3 OHM J (TAPPING)	△
R920	RF01Z129JA	R FUSIBLE	1W 1.2 OHM J A CURVE	△
ZMP10	PSMPJR0069	PCB MAIN RADIAL AS	DTY-2896TAF	
CA10	CBXF1H104Z	C CERA SEMI	50V F 0.1MF Z (TAPPING)	
CA11	CCXF1H473Z	C CERA	50V F 0.047MF Z (TAPPING)	
C101	CEXF1E470V	C ELECTRO	25V RSS 47MF (5X11) TP	
C102	CEXF1H479V	C ELECTRO	50V RSS 4.7MF (5X11) TP	
C103	CEXF1H479V	C ELECTRO	50V RSS 4.7MF (5X11) TP	
C104	CEXF1H100V	C ELECTRO	50V RSS 10MF (5X11) TP	
C105	CMXM2A104J	C MYLAR	100V 0.1MF J (TP)	
C106	CEXF1E330V	C ELECTRO	25V RSS 33MF (5X11) TP	
C111	CEXD1H109F	C ELECTRO	50V RND 1MF (5X11) TP	
C301	CMXM2A223J	C MYLAR	100V 0.022MF J TP	
C303	CMXM2A104J	C MYLAR	100V 0.1MF J (TP)	
C304	CMXM2A104J	C MYLAR	100V 0.1MF J (TP)	
C310	CMXM2A104J	C MYLAR	100V 0.1MF J (TP)	
C401	CEXF1H100V	C ELECTRO	50V RSS 10MF (5X11) TP	
C411	CEXF2C229V	C ELECTRO	160V RSS 2.2MF (8X11.5)TP	
C414	CMXM2A104J	C MYLAR	100V 0.1MF J (TP)	
C501	CCXF1H473Z	C CERA	50V F 0.047MF Z (TAPPING)	
C502	CEXF1H229V	C ELECTRO	50V RSS 2.2MF (5X11) TP	
C504	CEXF1E101V	C ELECTRO	25V RSS 100MF (6.3X11) TP	
C505	CEXF1H100V	C ELECTRO	50V RSS 10MF (5X11) TP	

LOC.	PART-CODE	PART-NAME	PART-DESCRIPTION	REMARK
C506	CEXF1E470V	C ELECTRO	25V RSS 47MF (5X11) TP	
C507	CEXF1H109V	C ELECTRO	50V RSS 1MF (5X11) TP	
C508	CEXF1H109V	C ELECTRO	50V RSS 1MF (5X11) TP	
C509	CMXL2E104K	C MYLAR	250V MEU 0.1MF K	
C510	CEXF1H109V	C ELECTRO	50V RSS 1MF (5X11) TP	
C511	CEXF1E470V	C ELECTRO	25V RSS 47MF (5X11) TP	
C514	CEXF1E470V	C ELECTRO	25V RSS 47MF (5X11) TP	
C515	CEXF1H109V	C ELECTRO	50V RSS 1MF (5X11) TP	
C525	CMXM2A473J	C MYLAR	100V 0.047MF J (TP)	
C601	CXCH1H680J	C CERA	50V CH 68PF J (TAPPING)	
C602	CEXF1H470V	C ELECTRO	50V RSS 47MF (6.3X11) TP	
C606	CEXF1H479V	C ELECTRO	50V RSS 4.7MF (5X11) TP	
C607	CEXF1H479V	C ELECTRO	50V RSS 4.7MF (5X11) TP	
C608	CEXF1H100V	C ELECTRO	50V RSS 10MF (5X11) TP	
C609	CEXF1E470V	C ELECTRO	25V RSS 47MF (5X11) TP	
C610	CEXF1H100V	C ELECTRO	50V RSS 10MF (5X11) TP	
C611	CEXF1H339V	C ELECTRO	50V RSS 3.3MF (5X11) TP	
C612	CEXF1H109V	C ELECTRO	50V RSS 1MF (5X11) TP	
C613	CEXF1H109V	C ELECTRO	50V RSS 1MF (5X11) TP	
C614	CEXF1H109V	C ELECTRO	50V RSS 1MF (5X11) TP	
C615	CEXF1H109V	C ELECTRO	50V RSS 1MF (5X11) TP	
C616	CEXF1H100V	C ELECTRO	50V RSS 10MF (5X11) TP	
C618	CEXF1E470V	C ELECTRO	25V RSS 47MF (5X11) TP	
C619	CEXF1H100V	C ELECTRO	50V RSS 10MF (5X11) TP	
C620	CEXF1H479V	C ELECTRO	50V RSS 4.7MF (5X11) TP	
C621	CEXF1H100V	C ELECTRO	50V RSS 10MF (5X11) TP	
C622	CEXF1H479V	C ELECTRO	50V RSS 4.7MF (5X11) TP	
C623	CEXF1E470V	C ELECTRO	25V RSS 47MF (5X11) TP	
C625	CEXF1H100V	C ELECTRO	50V RSS 10MF (5X11) TP	
C626	CEXF1H100V	C ELECTRO	50V RSS 10MF (5X11) TP	
C701	CEXF1E470V	C ELECTRO	25V RSS 47MF (5X11) TP	
C702	CEXF1H109V	C ELECTRO	50V RSS 1MF (5X11) TP	
C703	CMXM2A104J	C MYLAR	100V 0.1MF J (TP)	
C704	CMXM2A104J	C MYLAR	100V 0.1MF J (TP)	
C705	CEXF1E470V	C ELECTRO	25V RSS 47MF (5X11) TP	
C706	CMXB1H224J	C MYLAR	50V EU 0.22MF J (TP)	
C707	CEXF1H100V	C ELECTRO	50V RSS 10MF (5X11) TP	
C708	CEXF1H109V	C ELECTRO	50V RSS 1MF (5X11) TP	
C709	CMXM2A104J	C MYLAR	100V 0.1MF J (TP)	
C710	CXCH1H331J	C CERA	50V CH 330PF J (TAPPING)	
C716	CXCH1H309J	C CERA	50V CH 3PF J (TAPPING)	
C717	CXCH1H330J	C CERA	50V CH 33PF J (TAPPING)	

LOC.	PART-CODE	PART-NAME	PART-DESCRIPTION	REMARK
C727	CMXM2A104J	C MYLAR	100V 0.1MF J (TP)	
C803	CCXF3A472Z	C CERA	1KV F 4700PF Z (T)	△
C804	CCXF3A472Z	C CERA	1KV F 4700PF Z (T)	△
C807	CCXB3A471K	C CERA	1KV B 470PF K (T)	
C808	CEXF2A100V	C ELECTRO	100V RSS 10MF (6.3X11) TP	
C809	CCXB3A471K	C CERA	1KV B 470PF K (T)	
C811	CEXF1E221V	C ELECTRO	25V RSS 220MF (8X11.5) TP	
C812	CEXF1E221V	C ELECTRO	25V RSS 220MF (8X11.5) TP	
C816	CEXF1E101V	C ELECTRO	25V RSS 100MF (6.3X11) TP	
C817	CEXF1E470V	C ELECTRO	25V RSS 47MF (5X11) TP	
C818	CEXF1E101V	C ELECTRO	25V RSS 100MF (6.3X11) TP	
C819	CEXF1E101V	C ELECTRO	25V RSS 100MF (6.3X11) TP	
C822	CEXF1E470V	C ELECTRO	25V RSS 47MF (5X11) TP	
C823	CEXF1H109V	C ELECTRO	50V RSS 1MF (5X11) TP	
C968	CMXL2E104K	C MYLAR	250V MEU 0.1MF K	
C969	CMXL2E104K	C MYLAR	250V MEU 0.1MF K	
C970	CMXL2E104K	C MYLAR	250V MEU 0.1MF K	
F801A	4857415001	CLIP FUSE	PFC5000-0702	△
F801B	4857415001	CLIP FUSE	PFC5000-0702	△
QA01	TKTA1266Y-	TR	KTA1266Y (TP)	
QA02	TKTC3198Y-	TR	KTC3198Y	
QA03	TKTC3198Y-	TR	KTC3198Y	
Q301	TKTC3198Y-	TR	KTC3198Y	
Q402	T2SD1207T-	TR	2SD1207-T (TAPPING)	
Q404	TKTC3198Y-	TR	KTC3198Y	
Q405	TKTC3198Y-	TR	KTC3198Y	
Q406	TKTA1266Y-	TR	KTA1266Y (TP)	
Q501	TKTC3198Y-	TR	KTC3198Y	
Q502	TKTC3198Y-	TR	KTC3198Y	
Q601	TKTC3198Y-	TR	KTC3198Y	
Q602	TKTC3198Y-	TR	KTC3198Y	
Q603	TKTC3198Y-	TR	KTC3198Y	
Q604	TKTC3197—	TR	KTC3197 (TP)	
Q606	TKTC3198Y-	TR	KTC3198Y	
Q702	TKTC3198Y-	TR	KTC3198Y	
Q703	TKTC3198Y-	TR	KTC3198Y	
Q704	TKTC3198Y-	TR	KTC3198Y	
Q705	TKTA1266Y-	TR	KTA1266Y (TP)	
Q706	TKTA1266Y-	TR	KTA1266Y (TP)	
Q707	TKTA1266Y-	TR	KTA1266Y (TP)	
Q708	TKTC3198Y-	TR	KTC3198Y	
Q709	TKTC3198Y-	TR	KTC3198Y	

LOC.	PART-CODE	PART-NAME	PART-DESCRIPTION	REMARK
Q711	TKTC3202Y-	TR	KTC3202Y (TP)	
Q801	TKTC3198Y-	TR	KTC3198Y	
Q802	TKTC3198Y-	TR	KTC3198Y	
SW700	5S50101090	SW TACT	SKHV17910A	
SW701	5S50101090	SW TACT	SKHV17910A	
SW702	5S50101090	SW TACT	SKHV17910A	
SW703	5S50101090	SW TACT	SKHV17910A	
SW704	5S50101090	SW TACT	SKHV17910A	
ZMP10	PSMPJA0069	PCB MAIN AXIAL AS	DTY-2896TAF	
A001	4859801393	PCB MAIN	330X246 D1B	
DA01	D1N4148—	DIODE	1N4148 (TAPPING)	
DA02	DMTZ5R6B—	DIODE ZENER	MTZ 5.6-B(TAPPING)	
DA03	DMTZ12C—	DIODE ZENER	MTZ-12C	
DA04	DMTZ5R6B—	DIODE ZENER	MTZ 5.6-B(TAPPING)	
DA05	DMTZ5R6B—	DIODE ZENER	MTZ 5.6-B(TAPPING)	
DA06	DMTZ5R6B—	DIODE ZENER	MTZ 5.6-B(TAPPING)	
DA07	DMTZ5R6B—	DIODE ZENER	MTZ 5.6-B(TAPPING)	
DA08	DMTZ5R6B—	DIODE ZENER	MTZ 5.6-B(TAPPING)	
DA09	DMTZ5R6B—	DIODE ZENER	MTZ 5.6-B(TAPPING)	
DA10	DMTZ5R6B—	DIODE ZENER	MTZ 5.6-B(TAPPING)	
DA11	DMTZ5R6B—	DIODE ZENER	MTZ 5.6-B(TAPPING)	
DA12	DMTZ5R6B—	DIODE ZENER	MTZ 5.6-B(TAPPING)	
DA13	DMTZ5R6B—	DIODE ZENER	MTZ 5.6-B(TAPPING)	
DA14	DMTZ5R6B—	DIODE ZENER	MTZ 5.6-B(TAPPING)	
DA15	DMTZ5R6B—	DIODE ZENER	MTZ 5.6-B(TAPPING)	
DA16	DMTZ5R6B—	DIODE ZENER	MTZ 5.6-B(TAPPING)	
DA20	DMTZ5R6B—	DIODE ZENER	MTZ 5.6-B(TAPPING)	
DA21	DMTZ5R6B—	DIODE ZENER	MTZ 5.6-B(TAPPING)	
DA22	DMTZ5R6B—	DIODE ZENER	MTZ 5.6-B(TAPPING)	
D101	D1N4148—	DIODE	1N4148 (TAPPING)	
D301	DMTZ220—	DIODE ZENER	MTZ 22-D	
D302	DUZ5R1BM—	DIODE ZENER	UZ-5.1BM	
D401	D1N4003—	DIODE	1N4003 (TAPPING)	△
D402	D1N4003—	DIODE	1N4003 (TAPPING)	△
D405	D1N4936GP-	DIODE	1N4936GP (TAPPING)	△
D407	DBYV95C—	DIODE	BYV95C (TAPPING)	△
D408	DBYV95C—	DIODE	BYV95C (TAPPING)	△
D410	DBYV95C—	DIODE	BYV95C (TAPPING)	△
D501	DMTZ5R1B—	DIODE ZENER	MTZ 5.1-B (TAPPING)	
D502	D1N4148—	DIODE	1N4148 (TAPPING)	
D503	D1N4148—	DIODE	1N4148 (TAPPING)	
D504	D1N4148—	DIODE	1N4148 (TAPPING)	

LOC.	PART-CODE	PART-NAME	PART-DESCRIPTION	REMARK
D505	D1N4148—	DIODE	1N4148 (TAPPING)	
D506	DUZ5R1BM—	DIODE ZENER	UZ-5.1BM	
D601	D1SS85TA-	DIODE	1SS85TA	
D602	D1SS85TA-	DIODE	1SS85TA	
D701	D1N4148—	DIODE	1N4148 (TAPPING)	
D702	D1N4148—	DIODE	1N4148 (TAPPING)	
D703	D1N4148—	DIODE	1N4148 (TAPPING)	
D704	D1N4148—	DIODE	1N4148 (TAPPING)	
D705	D1N4148—	DIODE	1N4148 (TAPPING)	
D706	D1N4148—	DIODE	1N4148 (TAPPING)	
D708	DMTZ5R6B—	DIODE ZENER	MTZ 5.6-B(TAPPING)	
D709	DMTZ5R6B—	DIODE ZENER	MTZ 5.6-B(TAPPING)	
D710	DMTZ5R6B—	DIODE ZENER	MTZ 5.6-B(TAPPING)	
D711	DMTZ5R6B—	DIODE ZENER	MTZ 5.6-B(TAPPING)	
D712	DMTZ5R6B—	DIODE ZENER	MTZ 5.6-B(TAPPING)	
D801	D1S1888—	DIODE	1S1888 (TAPPING)	△
D802	D1S1888—	DIODE	1S1888 (TAPPING)	△
D803	D1S1888—	DIODE	1S1888 (TAPPING)	△
D804	D1S1888—	DIODE	1S1888 (TAPPING)	△
D805	DBYV95C—	DIODE	BYV95C (TAPPING)	△
D806	DBYV95C—	DIODE	BYV95C (TAPPING)	△
D807	DBYV95C—	DIODE	BYV95C (TAPPING)	△
D808	DBYV95C—	DIODE	BYV95C (TAPPING)	△
D903	D1S1888—	DIODE	1S1888 (TAPPING)	
LA01	5CPZ109M04	COIL PEAKING	1UH 10.5MM K (LAL04TB)	
LA02	5CPZ109M04	COIL PEAKING	1UH 10.5MM K (LAL04TB)	
LA03	5CPZ109M04	COIL PEAKING	1UH 10.5MM K (LAL04TB)	
LA04	5CPZ109M04	COIL PEAKING	1UH 10.5MM K (LAL04TB)	
LA06	5CPZ109M04	COIL PEAKING	1UH 10.5MM K (LAL04TB)	
LA07	5CPZ109M04	COIL PEAKING	1UH 10.5MM K (LAL04TB)	
LA10	5CPZ100K04	COIL PEAKING	10UH 10.5MM K (LAL04TB)	
LA12	5CPZ100K04	COIL PEAKING	10UH 10.5MM K (LAL04TB)	
L101	5CPZ470K02	COIL PEAKING	47UH K (AXIAL 3.5MM)	
L301	5CPZ100K04	COIL PEAKING	10UH 10.5MM K (LAL04TB)	
L302	5CPZ100K04	COIL PEAKING	10UH 10.5MM K (LAL04TB)	
L601	5CPZ479K02	COIL PEAKING	4.7UH K (AXIAL 3.5MM)	
L602	5CPZ479K02	COIL PEAKING	4.7UH K (AXIAL 3.5MM)	
L603	5CPZ470K04	COIL PEAKING	47UH 10.5MM K (LAL04TB)	
L604	5CPZ479K02	COIL PEAKING	4.7UH K (AXIAL 3.5MM)	
L605	5CPZ479K02	COIL PEAKING	4.7UH K (AXIAL 3.5MM)	
L606	RD-4Z102J—	R CARBON FILM	1/4 IK OHM J	
L607	5CPZ100K04	COIL PEAKING	10UH 10.5MM K (LAL04TB)	



LOC.	PART-CODE	PART-NAME	PART-DESCRIPTION	REMARK
L608	5CPZ100K04	COIL PEAKING	10UH 10.5MM K (LAL04TB)	
L701	5CPZ689K02	COIL PEAKING	6.8UH K (AXIAL 3.5MM)	
L804	5MC0000100	COIL BEAD	MD-5 (HC-3550)	
RA01	RD-4Z101J-	R CARBON FILM	1/4 100 OHM J	
RA02	RD-4Z221J-	R CARBON FILM	1/4 220 OHM J	
RA03	RD-4Z221J-	R CARBON FILM	1/4 220 OHM J	
RA04	RD-4Z221J-	R CARBON FILM	1/4 220 OHM J	
RA05	RD-4Z103J-	R CARBON FILM	1/4 10K OHM J	
R301	RD-4Z472J-	R CARBON FILM	1/4 4.7K OHM J	
R302	RD-2Z129J-	R CARBON FILM	1/2 1.2 OHM J	
R303	RD-2Z129J-	R CARBON FILM	1/2 1.2 OHM J	
R304	RD-2Z220J-	R CARBON FILM	1/2 22 OHM J	
R305	RD-2Z101J-	R CARBON FILM	1/2 100 OHM J	
R306	RD-2Z101J-	R CARBON FILM	1/2 100 OHM J	
R307	RD-4Z101J-	R CARBON FILM	1/4 100 OHM J	
R308	RD-4Z472J-	R CARBON FILM	1/4 4.7K OHM J	
R309	RD-4Z752J-	R CARBON FILM	1/4 7.5K OHM J	
R333	RD-4Z302J-	R CARBON FILM	1/4 3K OHM J	
R401	RD-4Z272J-	R CARBON FILM	1/4 2.7K OHM J	
R403	RD-4Z220J-	R CARBON FILM	1/4 22 OHM J	
R404	RD-4Z102J-	R CARBON FILM	1/4 1K OHM J	
R405	RD-2Z470J-	R CARBON FILM	1/2 47 OHM J	
R409	RD-4Z472J-	R CARBON FILM	1/4 4.7K OHM J	
R501	RD-4Z684J-	R CARBON FILM	1/4 680K OHM J	
R502	RD-4Z334J-	R CARBON FILM	1/4 330K OHM J	
R503	RD-4Z103J-	R CARBON FILM	1/4 10K OHM J	
R603	RD-4Z123J-	R CARBON FILM	1/4 12K OHM J	
R604	RD-4Z123J-	R CARBON FILM	1/4 12K OHM J	
R605	RD-4Z101J-	R CARBON FILM	1/4 100 OHM J	
R606	RD-4Z101J-	R CARBON FILM	1/4 100 OHM J	
R607	RD-4Z223J-	R CARBON FILM	1/4 22K OHM J	
R608	RD-2Z151J-	R CARBON FILM	1/2 150 OHM J	
R609	RD-2Z151J-	R CARBON FILM	1/2 150 OHM J	
R610	RD-4Z102J-	R CARBON FILM	1/4 1K OHM J	
R702	RD-4Z103J-	R CARBON FILM	1/4 10K OHM J	
R703	RD-4Z332J-	R CARBON FILM	1/4 3.3K OHM J	
R705	RD-4Z472J-	R CARBON FILM	1/4 4.7K OHM J	
R706	RD-4Z472J-	R CARBON FILM	1/4 4.7K OHM J	
R707	RD-4Z472J-	R CARBON FILM	1/4 4.7K OHM J	
R711	RD-4Z472J-	R CARBON FILM	1/4 4.7K OHM J	
R713	RD-4Z101J-	R CARBON FILM	1/4 100 OHM J	
R715	RD-4Z472J-	R CARBON FILM	1/4 4.7K OHM J	

LOC.	PART-CODE	PART-NAME	PART-DESCRIPTION	REMARK
R716	RD-4Z823J-	R CARBON FILM	1/4 82K OHM J	
R720	RD-4Z101J-	R CARBON FILM	1/4 100 OHM J	
R721	RD-4Z101J-	R CARBON FILM	1/4 100 OHM J	
R806	RD-4Z101J-	R CARBON FILM	1/4 100 OHM J	
R807	RD-4Z302J-	R CARBON FILM	1/4 3K OHM J	
R818	RC-2Z565J-	R CARBON COMP	1/2 5.6M OHM J	
R910	RD-4Z104J-	R CARBON FILM	1/4 100K OHM J	
R911	RD-4Z104J-	R CARBON FILM	1/4 100K OHM J	
R912	RD-4Z104J-	R CARBON FILM	1/4 100K OHM J	
R913	RC-2Z332J-	R CARBON COMP	1/2 3.3K OHM J	
R914	RC-2Z332J-	R CARBON COMP	1/2 3.3K OHM J	
R915	RC-2Z332J-	R CARBON COMP	1/2 3.3K OHM J	
R917	RD-4Z105J-	R CARBON FILM	1/4 1M OHM J	
R918	RD-2Z102J-	R CARBON FILM	1/2 1K OHM J	
Z502	5PMKT40MA-	FILTER CERA	MKT40MA100P	
ZSP10	PSSPPW0069	SPEAKER AS	DTY-2896TAF	
P601A	4850704N10	CONN AS	YH025-04+YST025+ULW=700	
SP01	4858313010	SPEAKER	SP-58126F03	
ZCG10	48519A5510	CRT GROUND AS	2801H-1015-2P	
ZDC10	58G0000103	COIL DEGAUSSING	DC-2701	
ZPK10	PSPKCP0069	PACKING AS	DTY-2896TAF	
M641	6520010100	STAPLE PIN	18M/M J D O	
M801	4858037300	BOX CARTON	DW-3	
M811	4858164200	PAD	EPS 2895	
M822	4858215400	BAG P.E	PE FILM	
ZTR10	48B3228B03	TRANSMITTER REMOCON	R-28B03	

**ENGINEER NOTE**



A series of horizontal dotted lines providing a template for writing notes.

**DAEWOO**

DAEWOO ELECTRONICS CO., LTD.  
686, AHYEON-DONG, MAPO-GU,  
SEOUL, KOREA.  
C.P.O. BOX 8003 SEOUL KOREA  
TELEX : DWELEC K28177-8  
F A X : (02) 364-5588,5305  
T E L : (02) 360-7360~4, 7315~7

S/M NO : CP775P-011

PRINTED DATE: DEC. 1997

CP-775 CHASSIS SCHEMATIC DIAGRAM

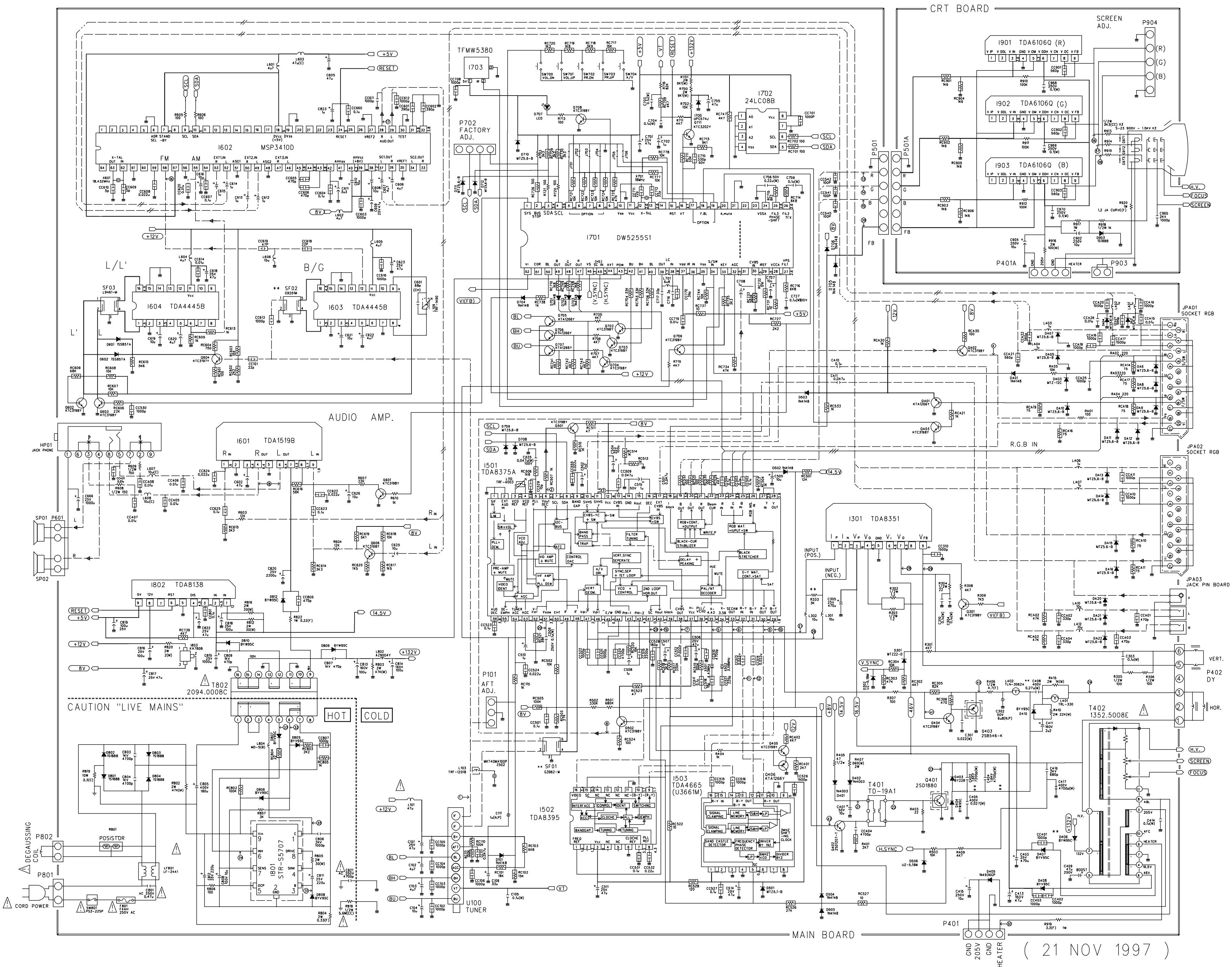

( 21 NOV 1997 )

CHASSIS : CP - 775

SCHEMATIC DIAGRAM

- \* PAL - B/G
- \* PAL/SECAM - B/G, D/K  
NTSC - 3.58/4.43 (AV)
- \* PAL/SECAM - B/G, D/K  
SECAM - L
- \* PAL - I

RESISTOR		CAPACITOR		COIL	
CARBON FLM	MM	ELECTRO	ME	BEARING	MM
R W-ORISE	MM (M)	CERAMIC	MC	CHOICE	MM (C)
CARBON COMP	MM (CC)	CERAMIC CH	MC (CH)	BEAD	MM (B)
FUSIBLE	MM (F)	ELECTRO MONOPOLAR	ME (MP)		
CEMENT	MM (C)	MYLAR	MC (M)		
CHP	MM (CHP)	CHP	ME (CHP)		

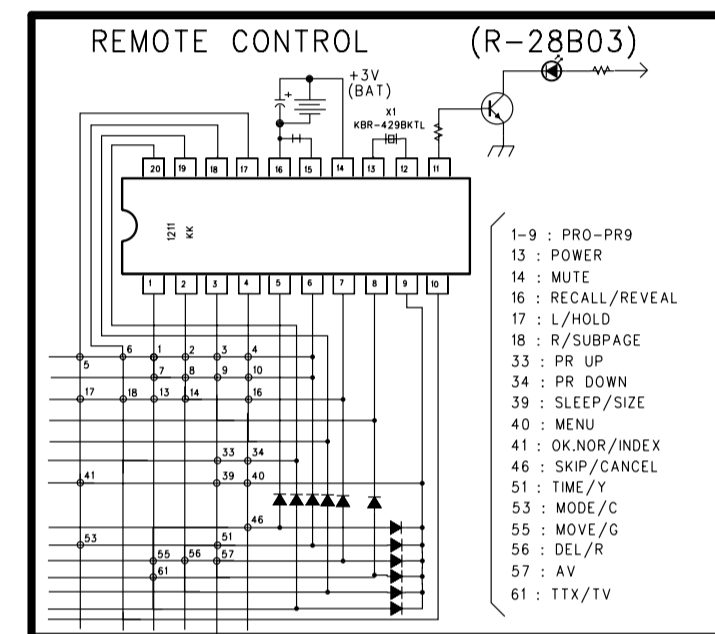

THE DIFFERENT PARTS FOR CRT

LOC.	28 INCH 1/2 COLOR	28 INCH PHILIPS	28 INCH PHILIPS	28 INCH URION	28 INCH URION
C432	1.6KV 7200pF(M)	←	←	←	1.6KV 8200pF(M)
C434	1.6KV 4700pF(M)	←	←	←	1.6KV 8200pF(M)
C438	400V 0.27uF(M)	←	←	←	400V 0.33uF(M)
C439	250V 47uF(M)	←	←	←	*
C440	50V 100uF	←	←	←	*
C452	*	←	←	←	250V 100uF
H401	TRL-330	←	←	←	TRL-2000
F501A	1Y025-06+Y51025 +05W-500	←	←	←	←
R333	1/4W 2K 0W	←	←	←	←
R339	1W 50K(1)	←	←	←	←
Z2131	280H-1015-2P	←	←	←	280H-1015-2P
Z2132	DC-2701	←	DC-2501	DC-2500	DC-2901

OPTION

#5	#6	#7	#8	#17	#19	TTX	TUNING/SOUND SYSTEM	ATS
H	H					WEST TTX		
L	H					EAST TTX		
H	L					TURKEY TTX		
	L	H	H				B/G (2-C, NICAM)	
	H	H	H				B/G, D/K (2-C, NICAM)	
	L	L	H				1/1 (NICAM)	
	H	L	H				1 (UHF ONLY, NICAM)	
	H	H	L				L/L' B/G (2-C, NICAM)	
	L	H	L				B/G, L/L' (2-C, NICAM)	
				H				ATS ON
				L				ATS OFF

THE DIFFERENT PARTS OF SYSTEM

SYSTEM	PAL-B/G	PAL-I	P/S-B/G, D/K	P/S-B/G, SECAM-L/L'
1 J701	X	X	JUMPER	X
2 J702	X	X	X	X
3 J703	JUMPER	X	X	X
4 J704	X	X	X	X
5 J705	X	X	X	JUMPER
6 J706	X	X	X	X
7 SF01	C3962M	C3962M	C3962M	C3962M
8 SF02	G9251M	K9260M	K9260M	G9251M
9 SF03	X	X	X	L9461M
10 Z502	MKT40MA	MKT40MA	X	MKT40MA
11 IS02	X	X	TD8395	TD8395
12 I604	X	X	X	TD4445B
13 UI00	3303KHC	DT2-IV17D	3303KHC	3303KHC
14 P801	CW-4232	CW-3222	KKP-419C	CW-4232
15 D601	X	X	X	1S2186
16 D602	X	X	X	1S2186

NOTE:

1. RESISTANCE IS SHOWN IN OHM. K=1000, M=1000000
2. UNLESS OTHERWISE NOTED IN SCHEMATIC ALL CAPACITOR VALUES ARE EXPRESSED IN uF.
3. VOLTAGES READ WITH "VTVM" FROM POINT INDICATED TO CHASSIS GROUND USING A COLOR BAR SIGNAL WITH ALL CONTROLS AT NORMAL LINE 230V AC VOLTAGE READINGS SHOWN ARE NORMAL VALUES AND MAY VARY +20% EXCEPT H.V
4. THIS CIRCUIT DIAGRAM IS A STANDARD ONE CIRCUIT PRINTED MAY BE SUBJECT TO CHANGE FOR PRODUCT IMPROVEMENT WITHOUT PRIOR NOTICE

WARNING:

BEFORE SERVICING THE CHASSIS, READ "X-RAY RADIATION", "SAFETY PRECAUTION", AND "PRODUCT SAFETY NOTICE" IN SERVICE MANUAL.

CAUTION TO SERVICE TECHNICIANS:

BEFORE RETURNING THE RECEIVER TO CUSTOMER, LEAKAGE CURRENT OR RESISTANCE MEASUREMENTS SHOULD BE PERFORMED TO DETERMINE THAT EXPOSED PARTS ARE PROPERLY INSULATED FROM THE SUPPLY CIRCUIT.

PRODUCT SAFETY NOTE :

THE COMPONENTS MARKED WITH  $\Delta$  ARE IMPORTANT FOR MAINTAINING THE SAFETY OF THE SET AND SHOULD BE REPLACED ONLY WITH TYPES IDENTICAL TO THOSE IN THE ORIGINAL OR SPECIFIED ONE IN THE PART LIST. DONT DEGRADE THE SAFETY OF THE SET THROUGH IMPROPER SERVICING.

WAVE FORMS

INPUT SIGNAL : PAL SYSTEM  
VIDEO : 8 STEP COLOR BAR 87.5K AM  
CONTROL ALL MAX MODE  
AUDIO : 1KHz SINE WAVE 60X FM

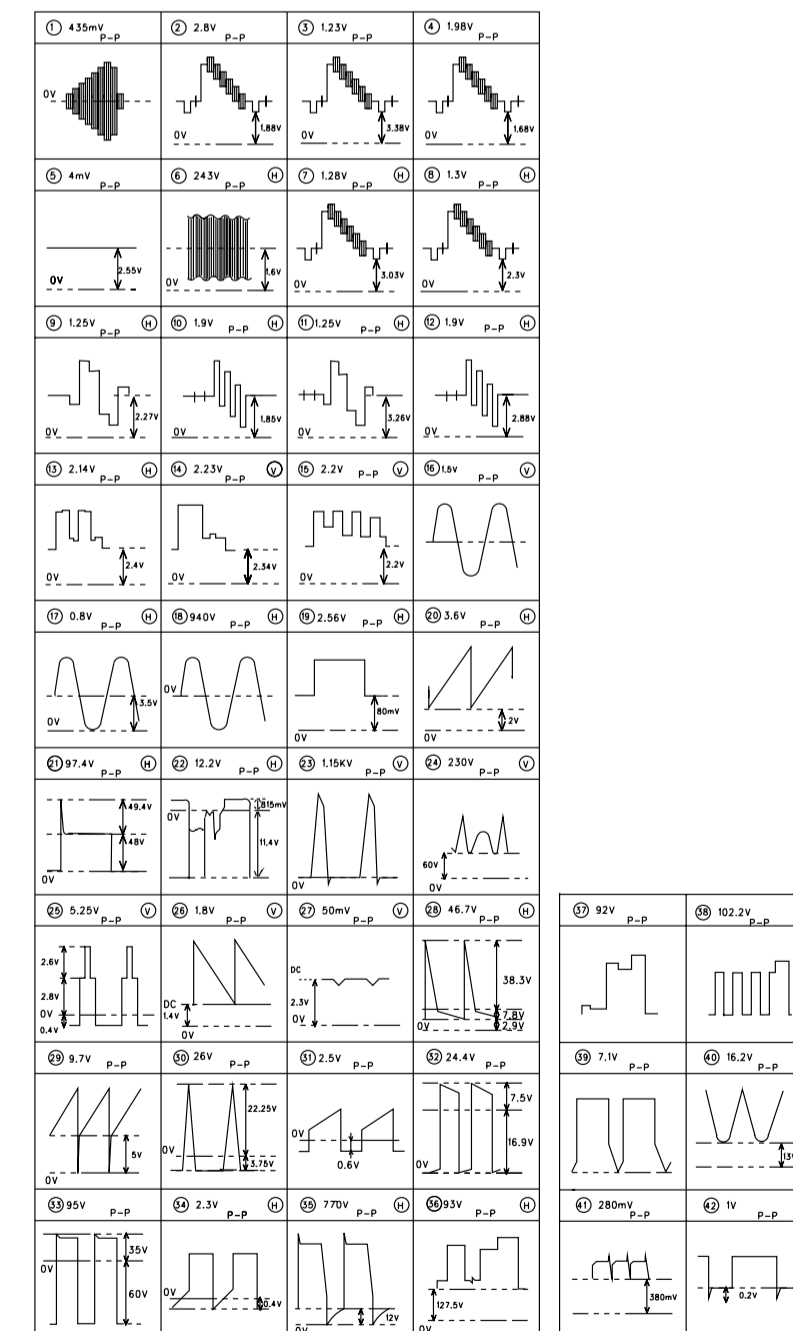

M E M O