



**AKAI**

**MINI HI-FI  
MICRO COMPONENT SYSTEM**

Model:  
QX-3700

**SERVICE MANUAL**

# AKAI

# SERVICE MANUAL

---

---

## *Mini Hi-Fi Micro Component System*

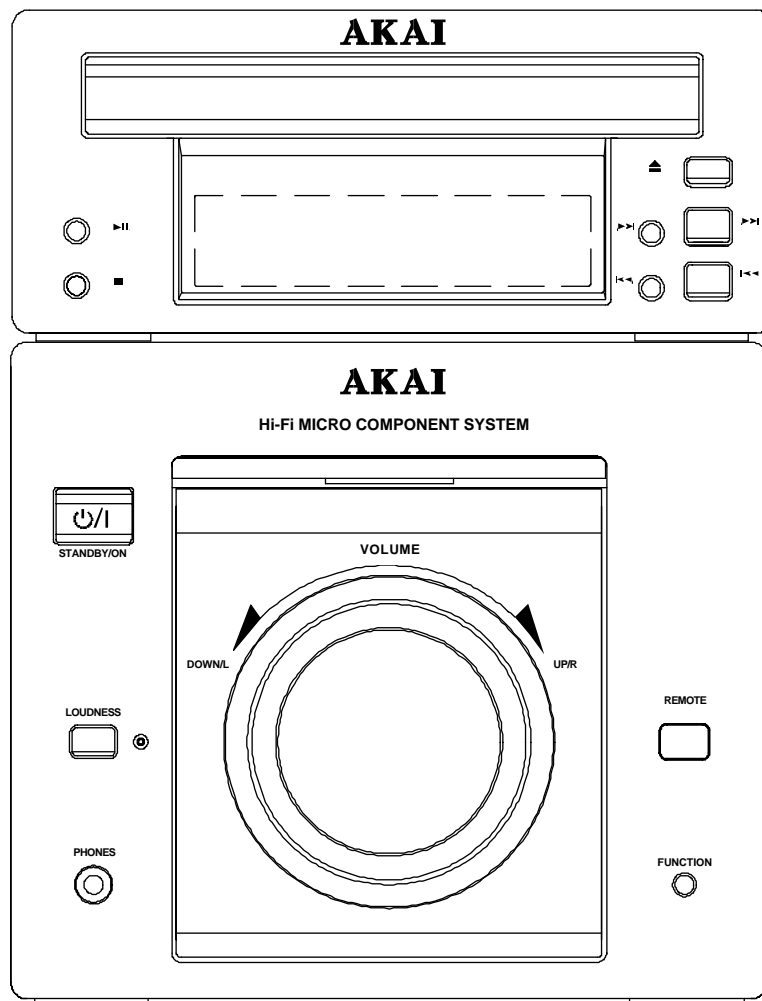

**QX-3700**

# Contents

- I. Safety instructions..... 2
- II. Specifications ..... 3
- III. Level List of Equipments & Instruments Required for Production ..... 6
- IV. Block diagram ..... 7
- V. Wiring diagram ..... 8
- VI. Schematic Diagram ..... 9
- VII. Component Diagrams ..... 10
- VIII. Exploded Diagram View and Parts List ..... 18

This manual is the latest at the time of printing, and does not include the modification which may be made after the printing, by the constant improvement of product.

# I. Safety instructions

When using electric products, basic precautions should always be followed, including the following:

1. **Read Instructions** – All the safety and operating instructions should be read before the appliance is operated.
2. **Retain Instructions** – The safety and operating instructions should be retained for future reference.
3. **Heed Warnings** – Adhere to all warnings on the appliance and in the operating instructions.
4. **Follow Instructions** – All operating and use instructions should be followed.
5. **Water and Moisture** – The appliance should not be used near water-for example, near a bathtub, wash-bowl, kitchen sink, laundry tub, in a wet basement, or near a swimming pool, etc.
6. **Carts and Stands** – The appliance should be used only with a cart or stand that is recommended by the manufacturer. An appliance and cart combination should be moved with care. Quick stops, excessive force, and uneven surfaces may cause the appliance and cart combination to overturn.
 

**Portable cart warning**
7. **Wall or Ceiling Mounting** – The appliance should be mounted to a wall or ceiling only as recommended by the manufacturer.
8. **Ventilation** – The appliance should be situated so that its location or position does not interfere with its proper ventilation. For example, the appliance should not be situated on a bed, sofa, rug or similar surface that may block the ventilation openings; or placed in a built-in installation, such as a bookcase or cabinet that may impede the flow of air through the ventilation openings.
9. **Heat** – The appliance should be situated away from heat sources such as radiators, heat registers, stoves, or other appliance (including amplifier) which produce heat.
10. **Nonuse Periods** – The power cord of the appliance should be unplugged from the outlet when left unused for a long period of time.
11. **Power Sources** – The appliance should be connected to a power supply only of the type described in the operating instructions or as marked on the appliance.
12. **Power Lines** – An outdoor antenna should be located away from power lines.
13. **Power Cord Protection** – Power-supply cords should be routed so that they are not likely to be walked on or pinched by items placed upon or against them, paying particular attention to cords, at plugs, convenience receptacles, and the point where they exit from the appliance.
14. **Power requirements for multi voltage (not for all models)** – Before connecting the power cord, make sure that the voltage selector on the rear panel is set to the correct voltage for you area. If not, please set it correctly.
15. **Load** – For protecting the appliance from being damaged, rated load while is printed on the appliance or is explained in operation instruction, that should be connected to the speaker output of the appliance. Never short circuit the speaker output of the appliance when the appliance is working.
16. **Object and Liquid Entry** – Care should be taken so that objects do not fall and liquids are not spilled into the enclosure through openings.
17. **Cleaning** – Unplug the appliance from the wall outlet before cleaning. Do not use liquid cleaners or aerosol cleaner. Use a damp cloth for cleaning.
18. **Make your contribution to protect the environment** – Used batteries with the ISO symbol for recycling as well as small accumulators (rechargeable batteries), mini-batteries (cells) and starter batteries should not be thrown into the garbage can. Please leave them at an appropriate depot.

19. **Overloading** – Do not overload wall outlets and extension cords as this can result in a risk of fire or electric shock.
20. **Damage Requiring Service** – Unplug this appliance from the wall outlet and refer servicing to qualified service personnel under the following conditions:
  - a). The power-supply cord or the plug has been damaged;
  - b). Objects have been fallen, or liquid has been spilled into the appliance;
  - c). The appliance has been exposed to rain;
  - d). The appliance does not appear to operate normally or exhibits a marked change in performance;
  - e). The appliance has been dropped, or the enclosure damaged.

**WARNING**  
TO REDUCE THE RISK OF FIRE OR ELECTRIC SHOCK, DO NOT EXPOSE THIS APPLIANCE TO RAIN OR MOISTURE.



**CAUTION**  
RISK OF ELECTRIC SHOCK  
DO NOT OPEN



**CAUTION**  
TO REDUCE THE RISK OF ELECTRIC SHOCK, DO NOT REMOVE COVER (OR BACK). NO USER SERVICEABLE PARTS INSIDE. REFER SERVICING TO QUALIFIED SERVICE PERSONNEL.

The lightning flash with arrowhead symbol, within an equilateral triangle, is intended to alert the user to the presence of uninsulated “dangerous voltage” within the product’s enclosure; that may be of sufficient magnitude to constitute a risk of electric shock to persons.



The exclamation point within an equilateral triangle is intended to alert the user to the presence of important operating and maintenance (servicing) instructions in the literature accompanying the appliance.



## CLASS 1 LASER PRODUCT

This product contains a low power laser device. To ensure continued safety, do not remove any covers or attempt to gain access to the inside of the product. Refer any servicing to qualified personnel.

### A. CLASSIFICATION LABEL, PLACED ON EXTERIOR SURFACE

CLASS	1	LASER	PRODUCT
KLASSE	1	LASER	PRODUKT
LUOKAN	1	LASER	LAITE
KLASS	1	LASER	APPARAT

### B. WARNING LABEL, PLACED INSIDE THE UNIT

<p><b>CAUTION</b> ; INVISIBLE LASER RADIATION WHEN OPEN AND INTERLOCKS DEFEATED. AVOID EXPOSURE TO BEAM.</p> <p><b>ADVARSEL</b> ; USYNLIG LASERSTRÅLNING VID ÖPNING NÄR SÄKERHEDSÅRBJYDERE ELL. UDEAF FUNKTION UNDDÅ UDSTRÆLSELSE FOR STRÅLING.</p> <p><b>VARO</b> ; AVATTARESSA JA SUOJALUKITUS OHITETTÄESSÄ OLET ALTTIINA NÄKYMÄTTÖMÄLLE LASERSTRÄLTYVILLE.</p> <p><b>ÄLÄ KATSO SÄTEESEENI</b></p> <p><b>VARNING</b> ; ÖSYNLIG LASERSTRÅLNING NÄR DENNA DEL ÄR ÖPPNAD OCH SPRÄNEN ÄR UPPKOPPLAD. BEHÅRKA FJ STRÅL FÖN!</p>
--

## II. Specifications

### CONDITIONS OF SPECIFICATION MEASUREMENTS

#### 1. STANDARDS ENVIRONMENTAL CONDITIONS

TEMPERATURE : 23°C

HUMIDITY : 65%

IF NO DOUBT ARISES IN THE JUDEMENT, THE MEASUREMENT CAN BE MADE UNDER CONDITIONS OF TEMPERATURE 10 TO 35°C AND HUMIDITY 45 TO 85%.

#### 2. REATED POWER SUPPLY AC: 220V 50Hz

#### 3. LOAD IMPEDANCE

SPEAKER OUTPUT : RESISTIVE LOAD AS SPECIFIED.(4 OHM)

PREAMPLIFIER OUTPUT AND RECORDING OUTPUT : 47k OHM RESISTOR (± 5%)

VIDEO OUTPUT: 75 OHM

#### 4. STANDARD OPERATING CONDITION AND METHOD OF MEASUREMENT

a) OPERATION METHOD, SETTING POSITION OF THE UNIT STARTING CONDITION FOR THE MEASUREMENT SHOULD BE MAINTAINED FOR TESTS OF AMPLIFIER SECTION AS EIA-RS-490, FOR TEST OF TUNER SECTION AS IHF-T-200.

b) EXCEPT AS OTHERWISE SPECIFIED HEREIN, ALL TESTS SHALL BE MEASURED AT FRONT CHANNELS AND SET THE SELECTOR POSITION.

**MEASURED MODE**

c) MODULATION OF FM DODE 75KHz DEVIATION AUDIO 1KHz 75 OHM

d) MODULATION OF FM STEREO MPX. 67.5KHz DEVIATION

7.5KHz PILOT

AUDIO 1 KHz

e) MODULATION OF MW 30% MOD. AUDIO 1KHz

f) REF. OUTPUT

LINE OUT

### Specifications

#### 1. FM Section

FM Electrical Specifications (Text Point at Line Out)

Measurement Description	Specifications	Measurement Condition/Method/Remarks				
		1HF BPF	FM MODE	Measu. Freq.	SSG Level	Others
FM RANGE	87MHz~108MHz					
30dB S/N	≤20uV		Mono	98MHz	Adjust	
AUTO STOP SENSITIVITY	30±5dBuV		Auto	98MHz	Adjust	Output level ratio of modulation OFF to ON Pilot : ON, R ch : ON
OUTPUT LEVEL	0.50±0.1Vrms	Yes	Mono	98MHz	60dBu	Measure both channel test point at Line Out
STEREO SEPARATION	≥20dB	Yes	Auto	98MHz	60dBu	

## 2. MW Section

### i. MW Measurement Condition

- (a) Antenna Input : Loop Antenna
- (b) Measurement Frequency : Lower Center Upper  
All version 603kHz 1008kHz 1404kHz (In case of no comment, measure at center frequency.)
- (c) Modulation Frequency : In case of no comment, use 1kHz 30% modulation
- (e) Selectivity : Arithmetical mean of 2 values at  $\pm 10$ kHz deviated frequency
- (f) Measurement Point : Test Point (At line out)

### ii. MW Electrical Specifications

Measurement Description	Specifications	Measurement Condition/Method/Remarks		
		Meas.Freq.	SG Level	Others
AM RANGE	522KHz~1611KHz			
26dB S/N	$\leq 5.0$ mV/M	Center	Adjust	Output level ratio of modulation OFF to ON
AUTO STOP SENSITIVITY	20mV/M $\leq$ Auto Stop Sensitivity $\leq 5.0$ mV/M	Center	Adjust	Minimum input level of Auto Stop threshold
OUTPUT LEVEL	150-500Mvrms	Center	10mV/M	Measure both channel test point at Line Out

## 3. VCD Section

### VCD Measurement Condition

Measurement Point: At line out or video out

### 1. Electrical Specifications

No.	Test Item	Unit	Specification
1	Video Output Level	Vp-p	1.0 $\pm$ 0.2
2	Audio Output Level	Vrms	2.0+0.2/-1.0
3	Audio of Resp (20Hz~20KHz)	dB	$\leq \pm 3.5$
4	Audio S/N (A-WTD)	dB	$\geq 70$
5	Distortion & Noise (1KHz)	dB	$\leq -50$
6	Cross Talk L-R (Fundamental)	dB	$\geq 60$

### 2. Mechanical Specifications

No.	Test Item	Unit	Specification
1	Reading Time	S	<20 (S)
2	Ball Bound: Drop 8g Super Ball from 3cm Height		No AV Noise

#### 4. AMPLIFIER Section

##### i. AMPLIFIER Measurement Condition

- (a) Power Output : Measure without pre-heating
- (b) Source Impedance : Normally 600Ω
- (c) S/N : Measure the noise level without low frequency (≤ 80Hz) vibration
- (d) Frequency Response : Measure at -10dBs output (1kHz) by adjusting oscillator output
- (e) Difference of L/R ch : The output level difference between L ch and R ch at ± 3dB output
- (f) Other : In case of no comment, set volume maximum and 4Ω load

##### ii. AMPLIFIER Specifications

Measurement Description	Specifications	Measurement Condition/Method/Remarks						Measurement Method/Remarks
		Test Point	Input Selector	Input Signal		Output Level	Vol.	
				Freq.	Level			
Power Output	15±3W	SP out front	Line	1kHz	Adjust	Adjust THD 2%	MAX	Both channel drive/ 4Ω load
Distortion	Less than 2%	SP out	Line	1kHz	Adjust	12W	MAX	Both channel drive/ 4Ω load read best value when indicator of distortion meter is changing
Line Input Sensitivity	200±50mV	SP out	Line	1kHz	Adjust	Adjust THD 2%	MAX	
S/N	≥65dB	SP out	Line	4.7kΩ Terminate		5W	MAX	
Channel Separation	more than 30dB	SP out	Line	1kHz	Adjust	5W	MAX	Measure a ratio of leak level of L→R, R→L; Measured channel input terminal AUX: 4.7kΩ Terminate
Frequency Response	±2dB	SP out	Line	80Hz 12.5kHz	Adjust	+3dBs	MAX	Measure the level difference
Loudness	+10dB±5dB	H:10KHz L:100Hz	Line	1KHz	Adjust	---	30Bar	Difference from 1KHz out
Line Out Level	80±20mV	Line out	Line	1KHz	Adjust	Adjust THD 2%	MAX	

Measurement Description		Specifications	Measurement Condition/Method/Remarks						Measurement Method/Remarks
			Test Point	Input Selector	Input Signal		Output Level	Vol.	
					Freq.	Level			
Frequency Response		- 5.0 dB ± 3.0dB	SP	AUX	10Hz	Adjust	0dBs	MAX	Measure the level difference from 1kHz output
		- 4.0 dB ± 3.0dB	OUT		100kHz				
Super Bass		+ 10dB ± 3.0dB	SP OUT	AUX	70Hz	Adjust	0dBs	30	Measure the level difference ( S BASS ON)-(S BASS OFF) at 1kHz Volume Level 30 Position
Loudness Equalizer	Low	+ 6.0 dB ± 3.0dB - 10.0 dB ± 3.0dB	SP OUT	AUX	100Hz	Adjust	0dBs	30	Volume Level 30 Position
	High	+ 5.0 dB ± 3.0dB - 7.0 dB ± 3.0dB			10kHz				

### III. Level List of Equipments & Instruments Required for Production

NO.	Designation	Requirement	Reference Model	Remark
1	Standard signal Generator	EXT. MOD. Input Modulation: AM 0-60% FM 0-99.9KHz Frequency: 0.1-140MHz Level: -20-120dBu Output: 1-50W	LEADER 3216	1 set
2	AC voltmeter	Inter Resistance 1M-10MW	KENWOOD V7-171	2 set
3	Automatic Distortion Meter		VP7702C	1 set
4	CD Player Evaluation Filter		NF3346A	1 set
5	Multiplex Signal Generator		KIKU SUI 3400S	1 set
6	Oscilloscope	Max Frequency of input signal; 5MHz	KENWOOD CO-1305	2 set
7	Oscillator	Frequency of output signal; 20Hz-20kHz	KENWOOD AG-203A	2 set
8	Test Loop	Resistance: 50Ω Frequency: 100KHz~30MHz	LEADER LPA-070	1 set
9	WOW FLUTTER METER		MEGURO MK-668G	1 set



# IV. Block diagram

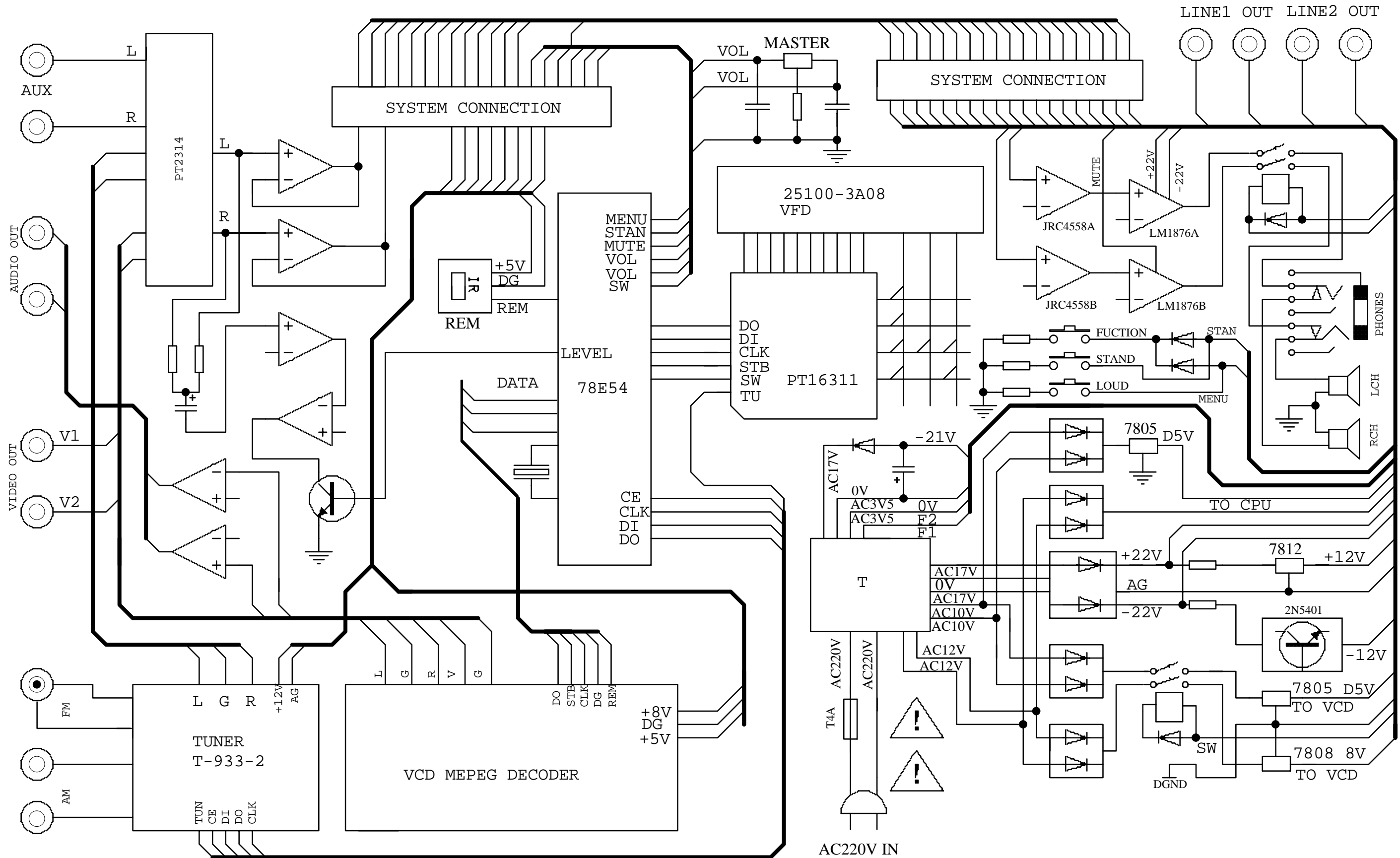

# V. Wiring diagram

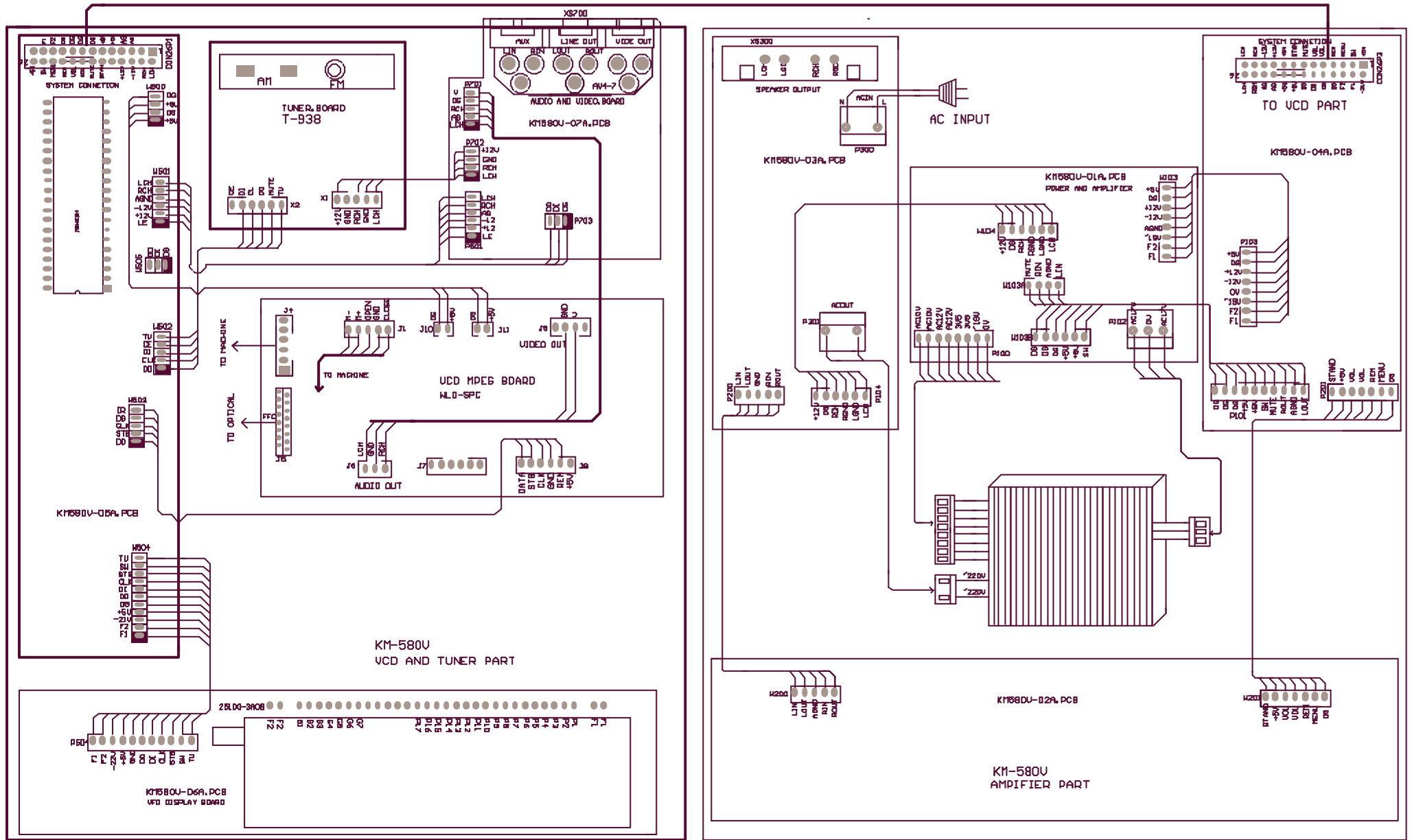

# VI. Schematic Diagram

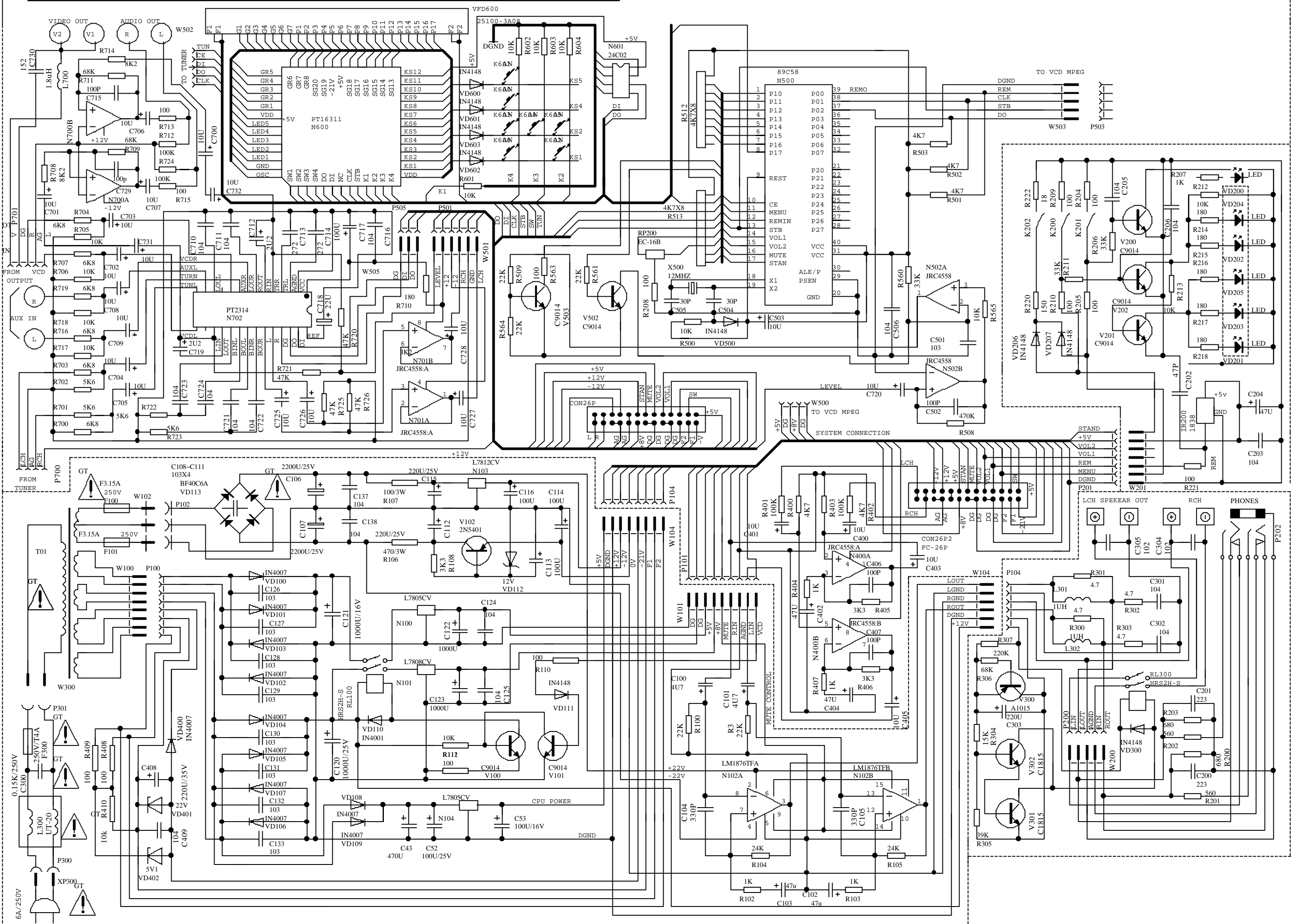

## VII. Component Diagrams

### i. AMP PCB Component Diagram

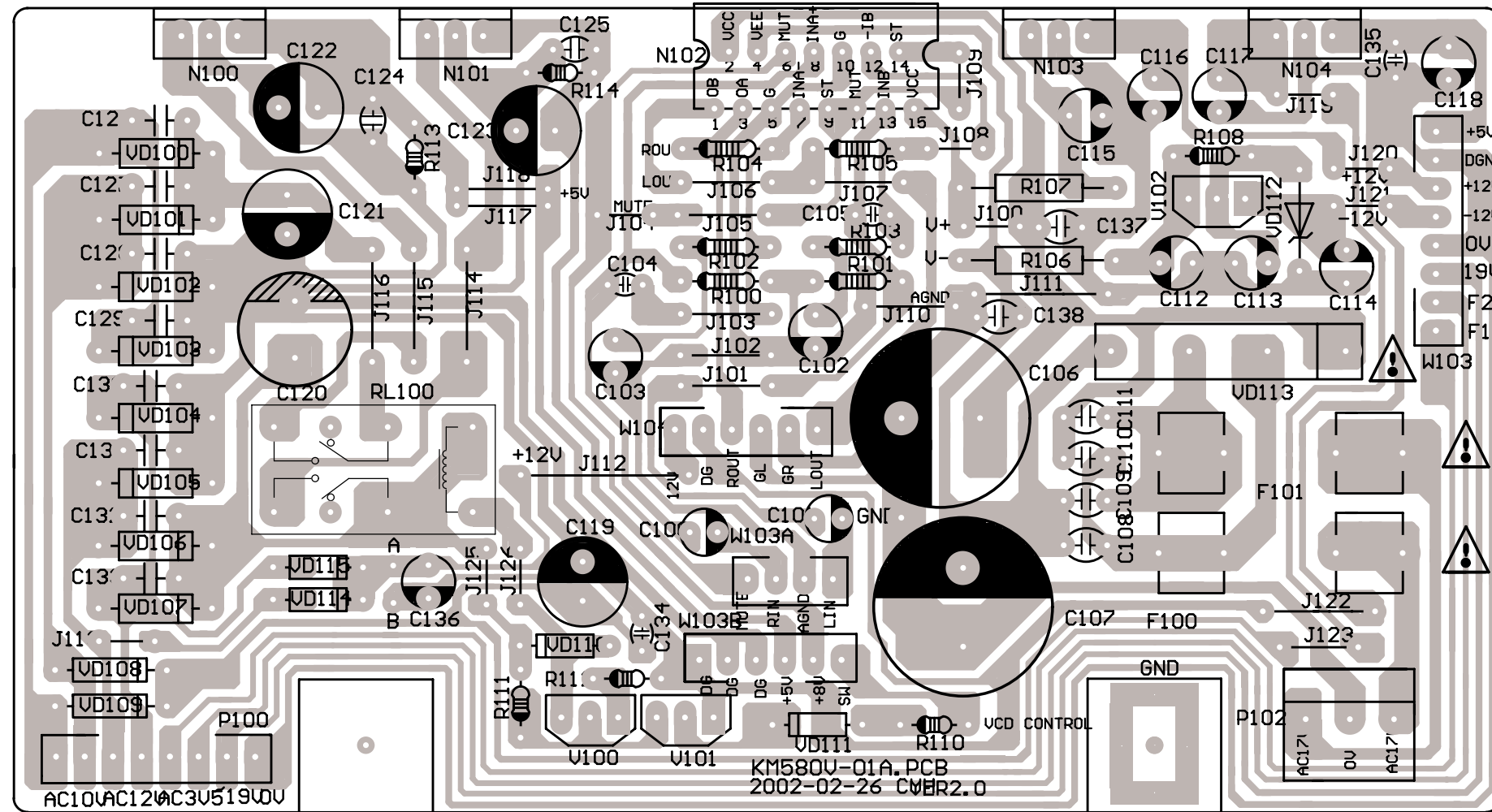

ii. AMP CONTROL PCB Component Diagram

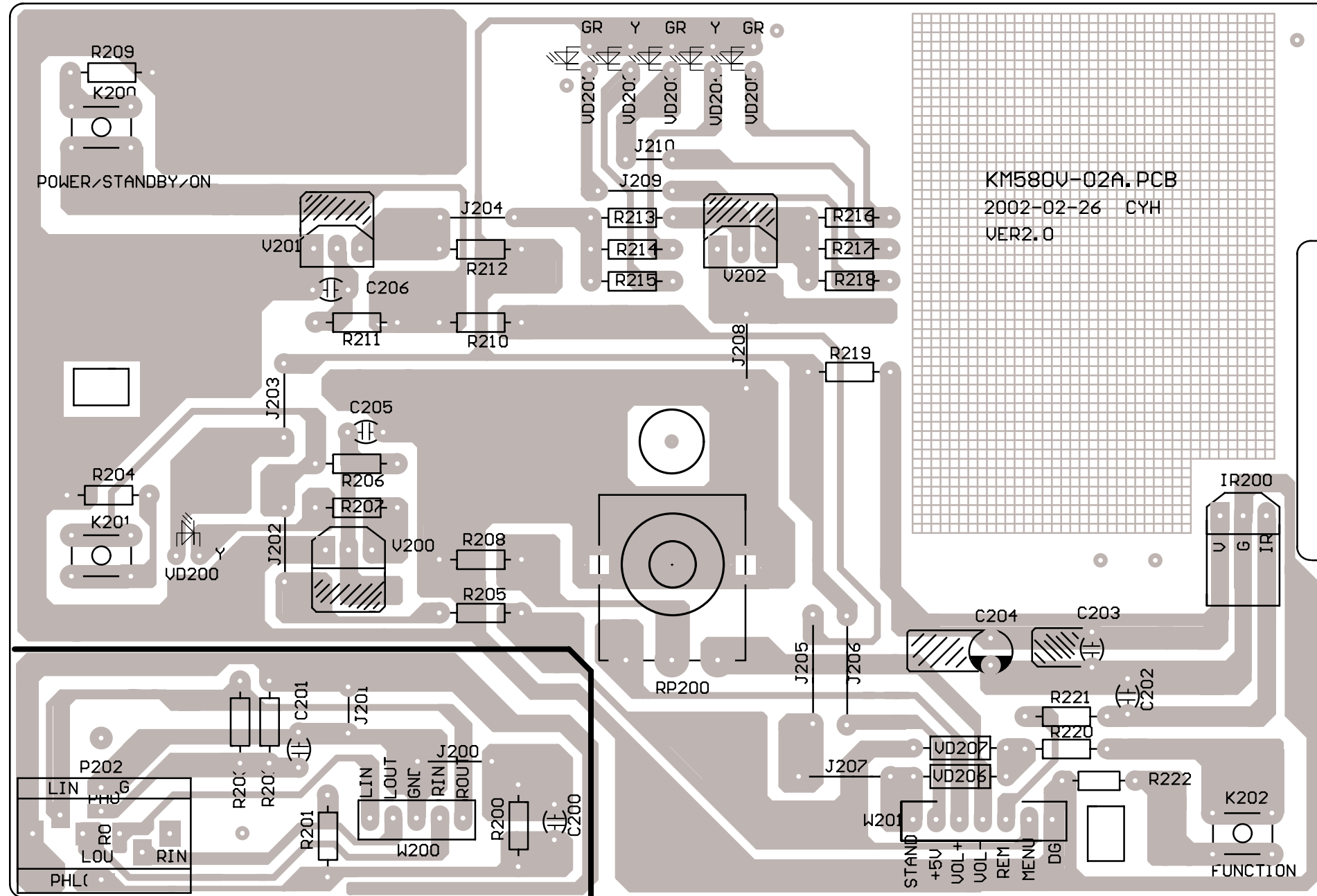

iii. AMP OUTPUT PCB Component Diagram

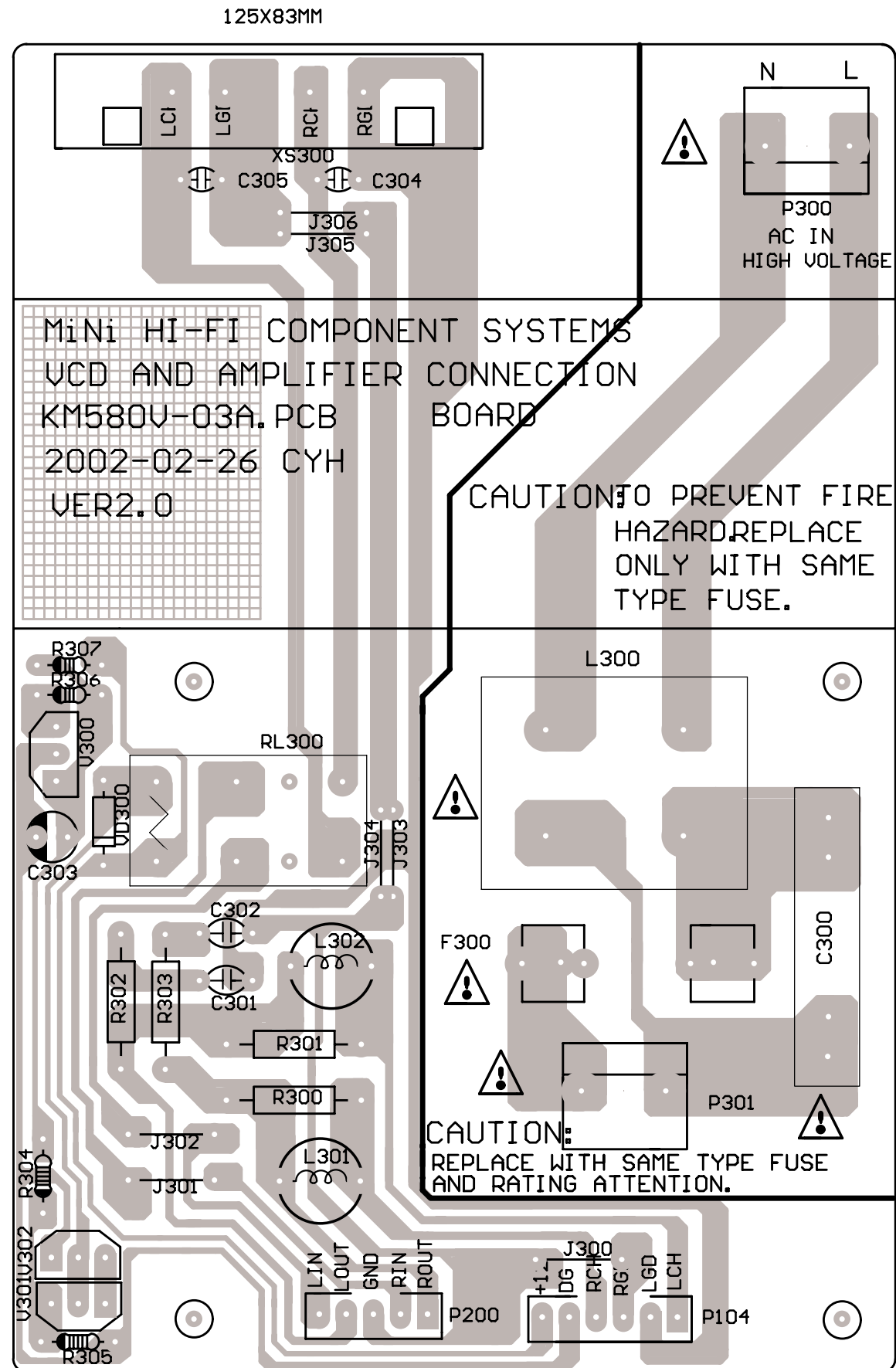

iv. CONNECTIVE PCB Component Diagram

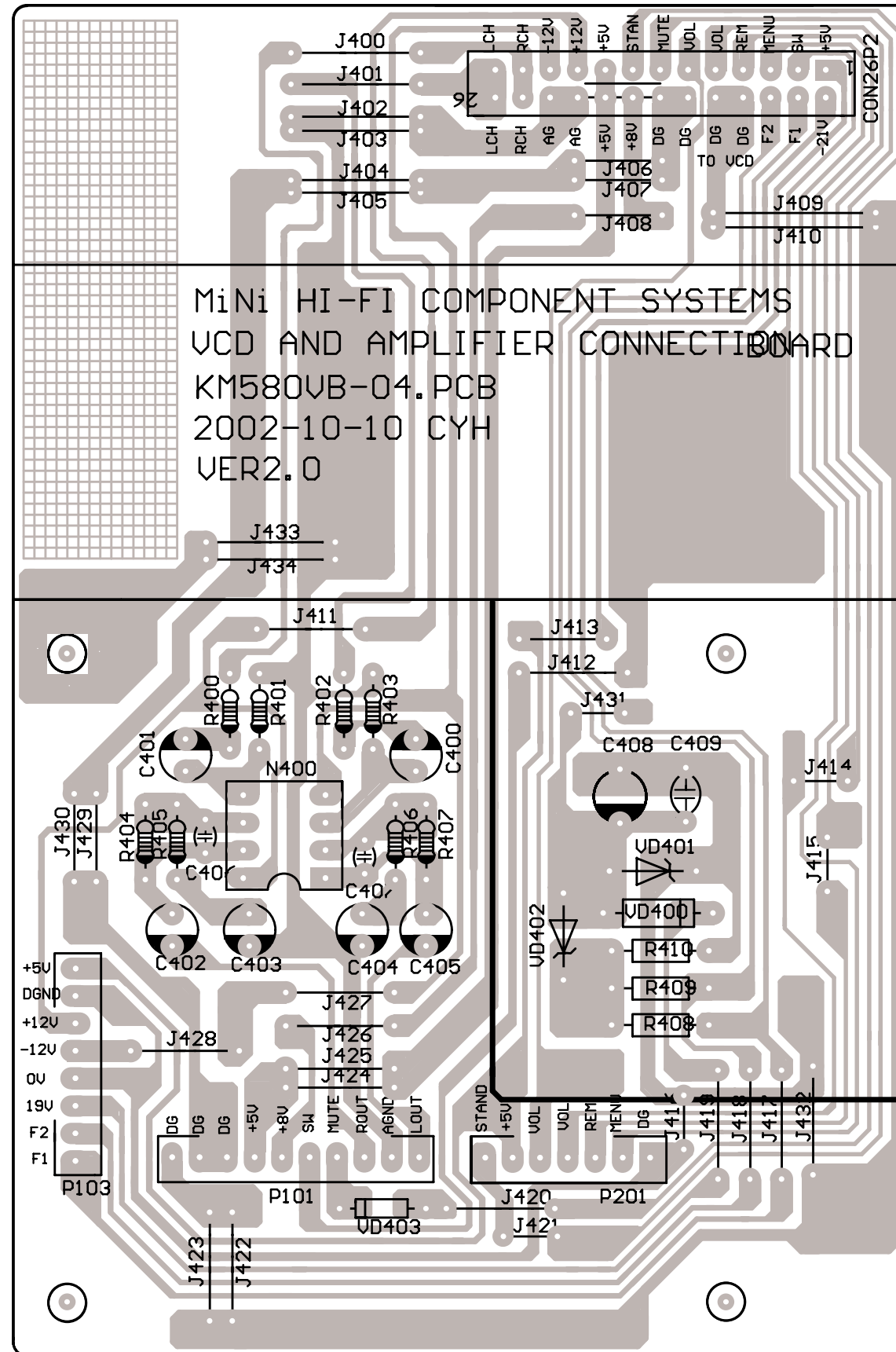

v. CPU CONTROL PCB Component Diagram

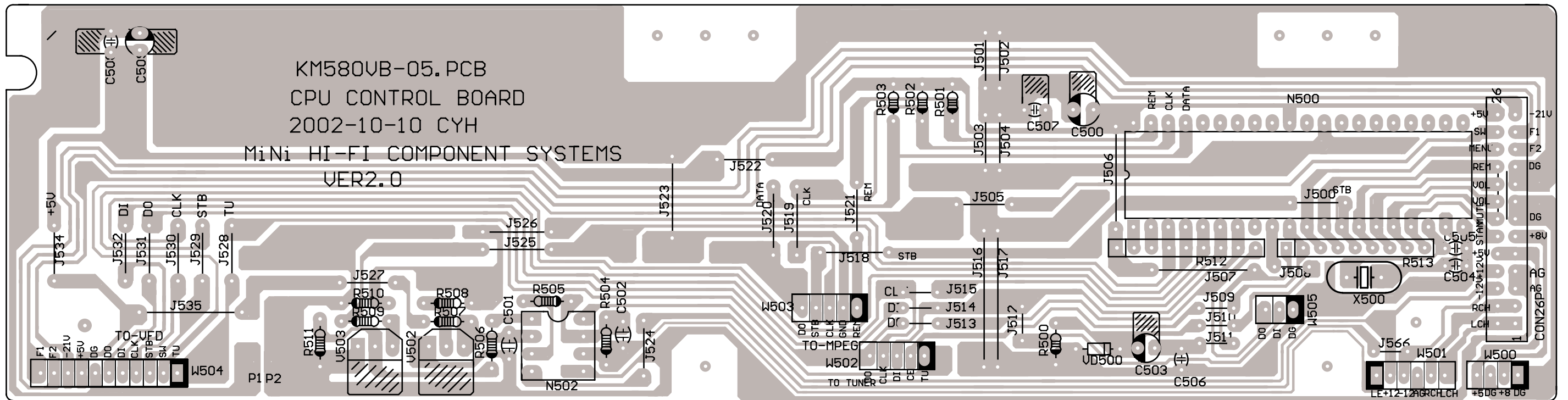



vi. VCD CONTROL PCB Component Diagram

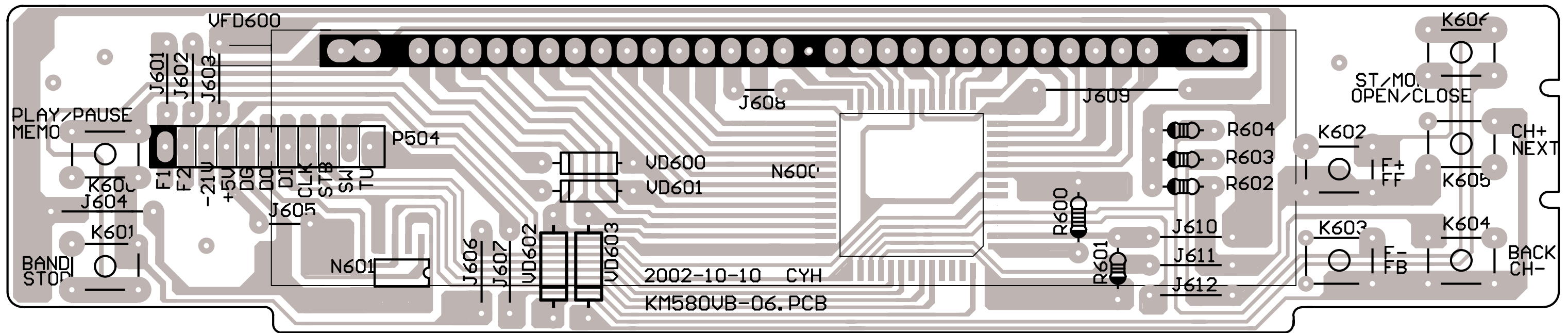

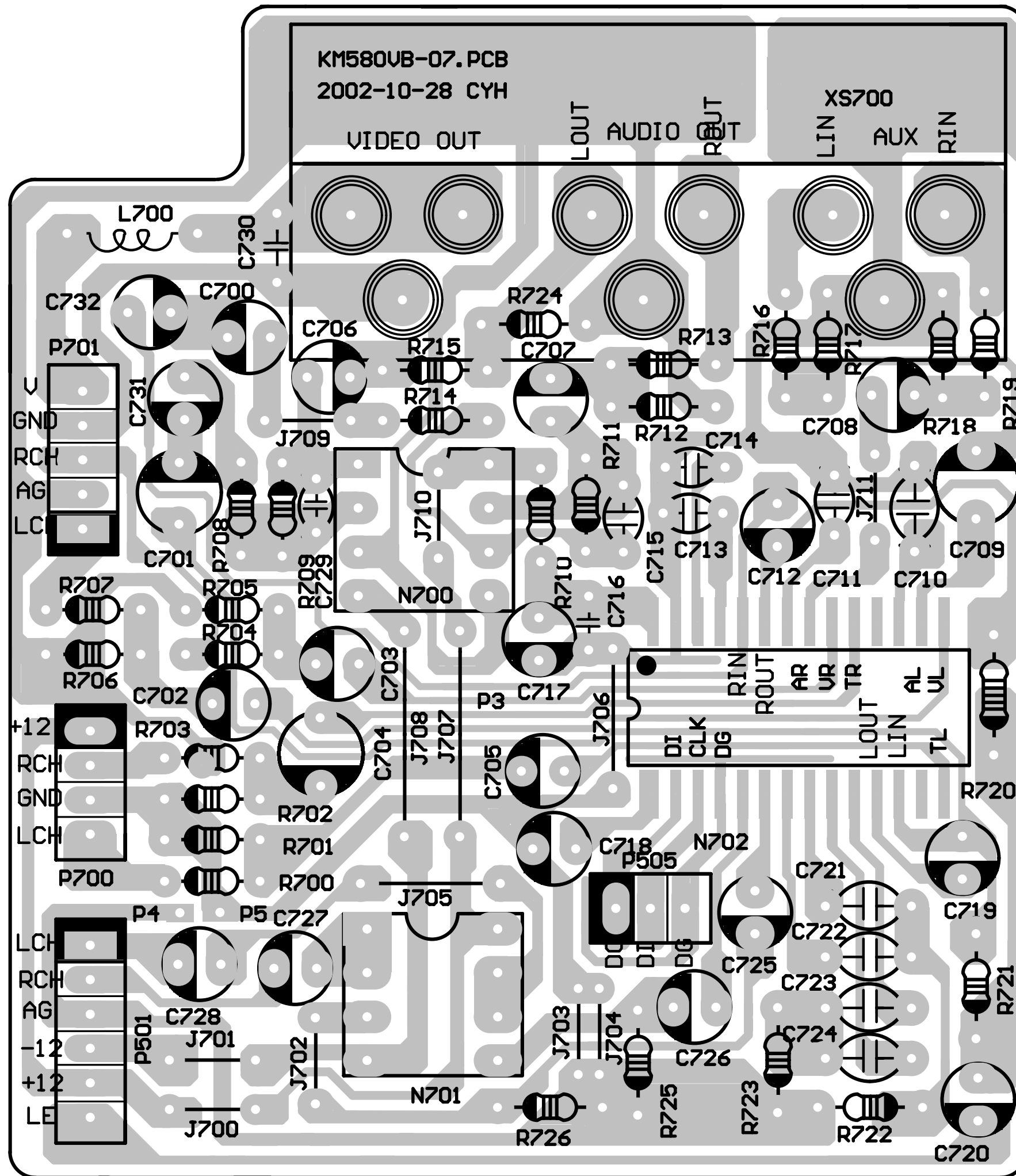

### viii. REMOTE HANDSET PCB Component Diagram

TOP SIDE SCREEN

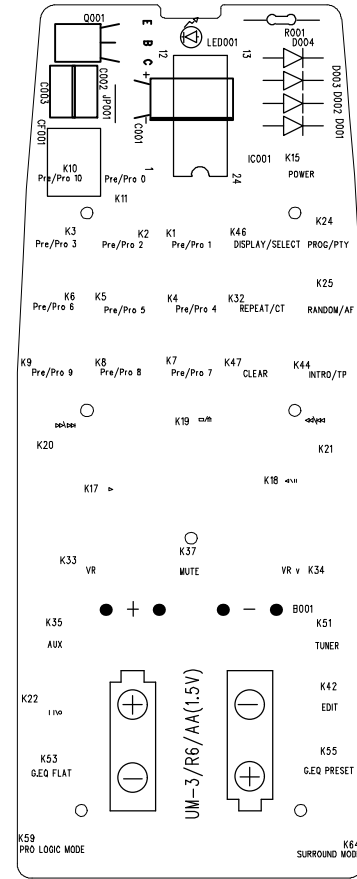

18 17 16 15 14 13 12 11 10 9 8 7 6 5 4 3 2 1  
K60 K59 K58 K57 K56 K55 K54 K53 K52 K51  
K48 K47 K46 K45 K44 K43 K42 K41 K40 K39 K38 K37 K36 K35 K34 K33 K32 K31 K30 K29 K28 K27 K26 K25 K24 K23 K22 K21 K20 K19 K18 K17 K16 K15 K14 K13 K12 K11 K10 K9 K8 K7 K6 K5 K4 K3 K2 K1 K0

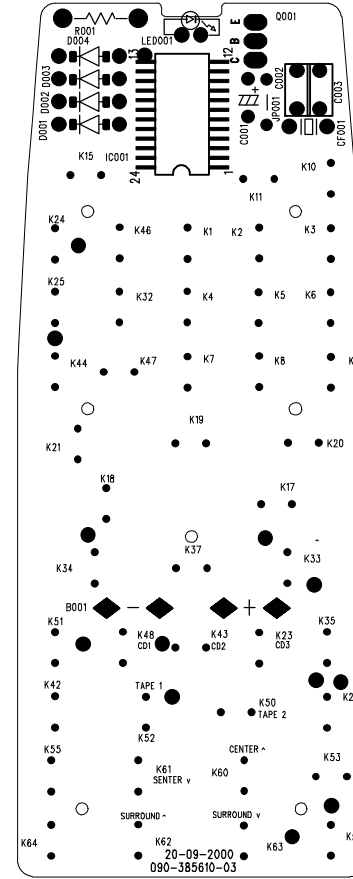

K60 K59 K58 K57 K56 K55 K54 K53 K52 K51  
K48 K47 K46 K45 K44 K43 K42 K41 K40 K39 K38 K37 K36 K35 K34 K33 K32 K31 K30 K29 K28 K27 K26 K25 K24 K23 K22 K21 K20 K19 K18 K17 K16 K15 K14 K13 K12 K11 K10 K9 K8 K7 K6 K5 K4 K3 K2 K1 K0

BOTTOM SIDE SCREEN

# VIII. Exploded Diagram View and Parts List

## A. VCD exploded

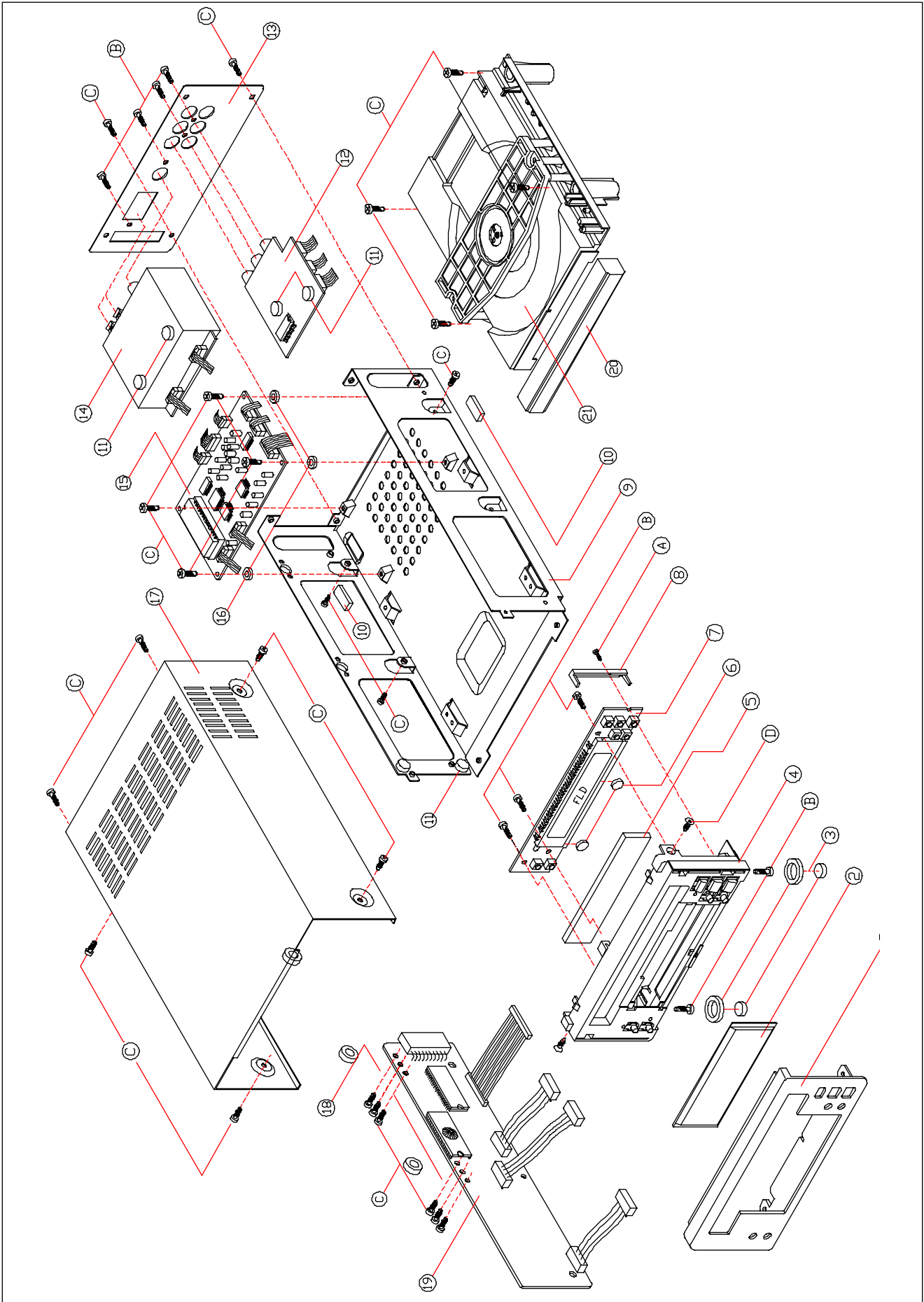

**Parts list for VCD exploded view diagram**

<b>Location</b>	<b>Part No.</b>	<b>Discription</b>	<b>QTY</b>
1	405-AA0902-05	PANEL FRONT	1
2	263-AA0901-06L	FRONT LENS	1
3	370-AA0801-01	FOOT CSH	2
4	227-AA0921-06S	MTB CV CD	1
5	260-AA0901-01L	LENS REAR	1
6		CSH	2
7	E7801-013006	FRONT CONTROL PCB ASSY	1
8	224-AA0902-01B	HOLD PCB	1
9	403-AA0903-01	CHASSIS BOTTOM	1
10	370-AA0802-01	FOOT CSH REAR	2
11	322-AA0801-01	SPOG SPR	6
12	E7801-013007	OUTPUT PCB ASSY	1
13	402-AA0903-05	REAR COVER	1
14	E7801-013009	TUNER PCB ASSY	1
15	E7801-013008	MPEG PCB ASSY	1
16	530-V58001-01	FIBER PAPER WASHER	4
17	401-AA0902-01	TOP CABINET	1
18	429-AA0901-01	BRACKET FOR PCB	2
19	E7801-013005	CPU PCB ASSY	1
20	239-AA0901-07S	CD DOOR	1
21	E7706-003001	MECHANISM VCD	1
A	610-200108-10	S-TAP. SCREW RND 2x8	1
B	610-300108-90	S-TAP. SCREW RND 3x8	9
C	610-300106-90	S-TAP. SCREW 3x6	25
D	611-300208-10	S-TAP. SCREW FLT 3x8	2

## B. AMP exploded

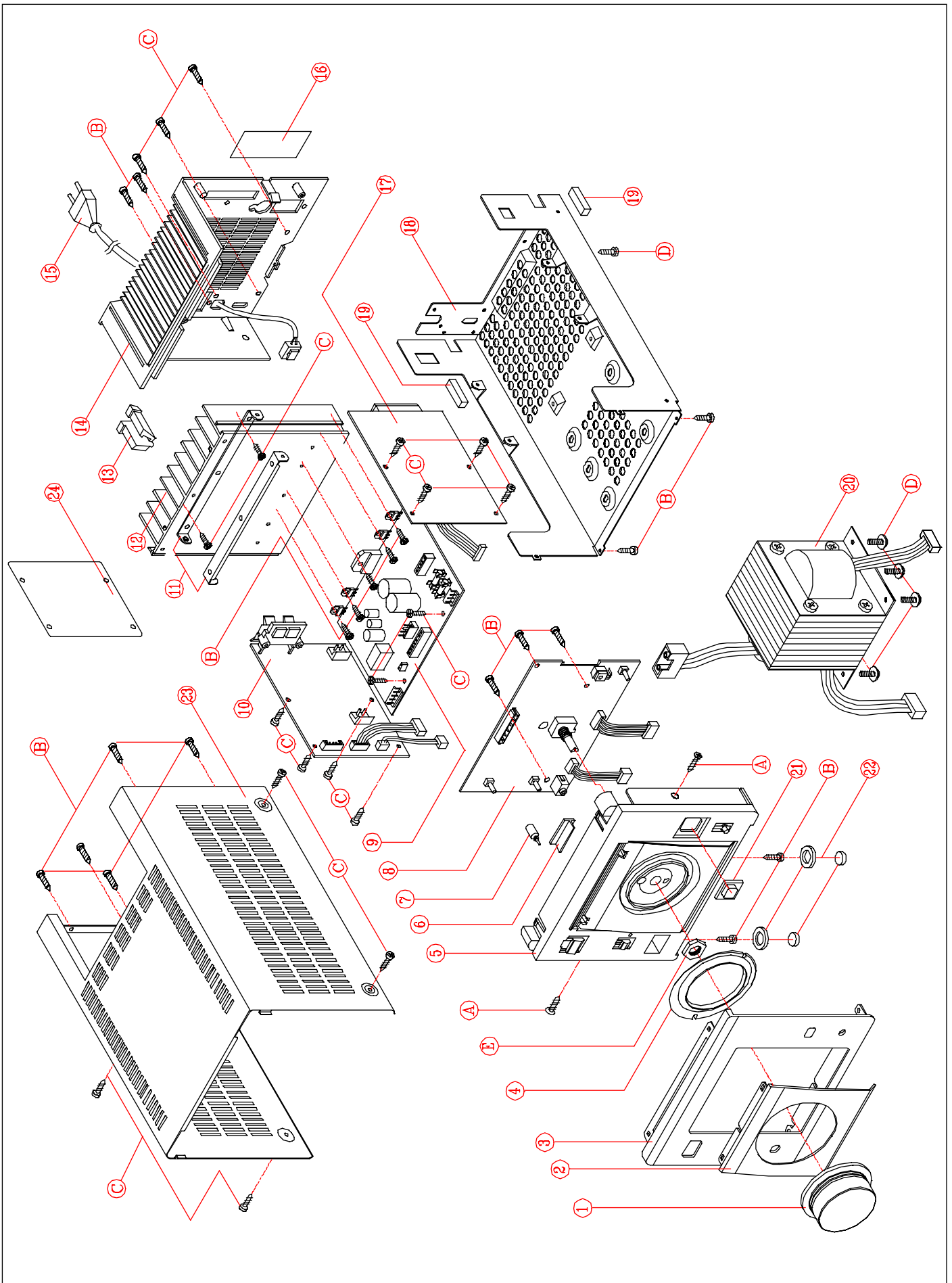

**Parts list for AMP exploded view diagram**

<b>Location</b>	<b>Part No.</b>	<b>Discription</b>	<b>QTY</b>
1	739-AA0802-04	ASY+VOL	1
2	405-AA0803-04	PNL FR B	1
3	405-AA0802-06	PNL FR A	1
4	289-AA0803-03L	RNG+VOL	1
5	227-AA0811-05S	BRACKET FOR COVER	1
6	269-AA0802-01K	L+AA 1	1
7	269-AA0803-01K	L+AA 2	1
8	E7801-013002	AMP CONTROL PCB	1
9	E7801-013001	AMP PCB	1
10	E7801-013003	AMP OUTPUT PCB	1
11	429-AA0801-1	BRACKET FOR PCB	2
12		HTSK	1
13	367-V58801-01	BSHG RELIEF	1
14	236-AA0811-22S	CABINET BACK	1
15	E3404-136001	AC LINE CORD	1
16	384-K58001-02H	BACK PLATE	1
17	E7801-013004	CONNECTIVE PCB	1
18	403-AA0803-01	CABINET BOTTOM	1
19	370-AA0802-01	FOOT CSH REAR	2
20	E5102-151001	TRANSFORMER	1
21	269-AA0821-01K	LENS+RCN FLTR	1
22	370-AA0801-01	FOOT CSH	2
23	401-AA0803-01	CABINET TOP	1
24	389-AA0802-01H	PLT SHD PCB	1
A	611-300208-10	S-TAP. SCREW FLT 3x8	2
B	610-300108-90	S-TAP. SCREW RND 3x8	12
C	610-300106-90	S-TAP. SCREW 3x6	19
D	612-400108-10	S-TAP. SCREW WHR 4x8	8
E	660-907520-11	NUT 9x11x2	1

**C. Remote handset**

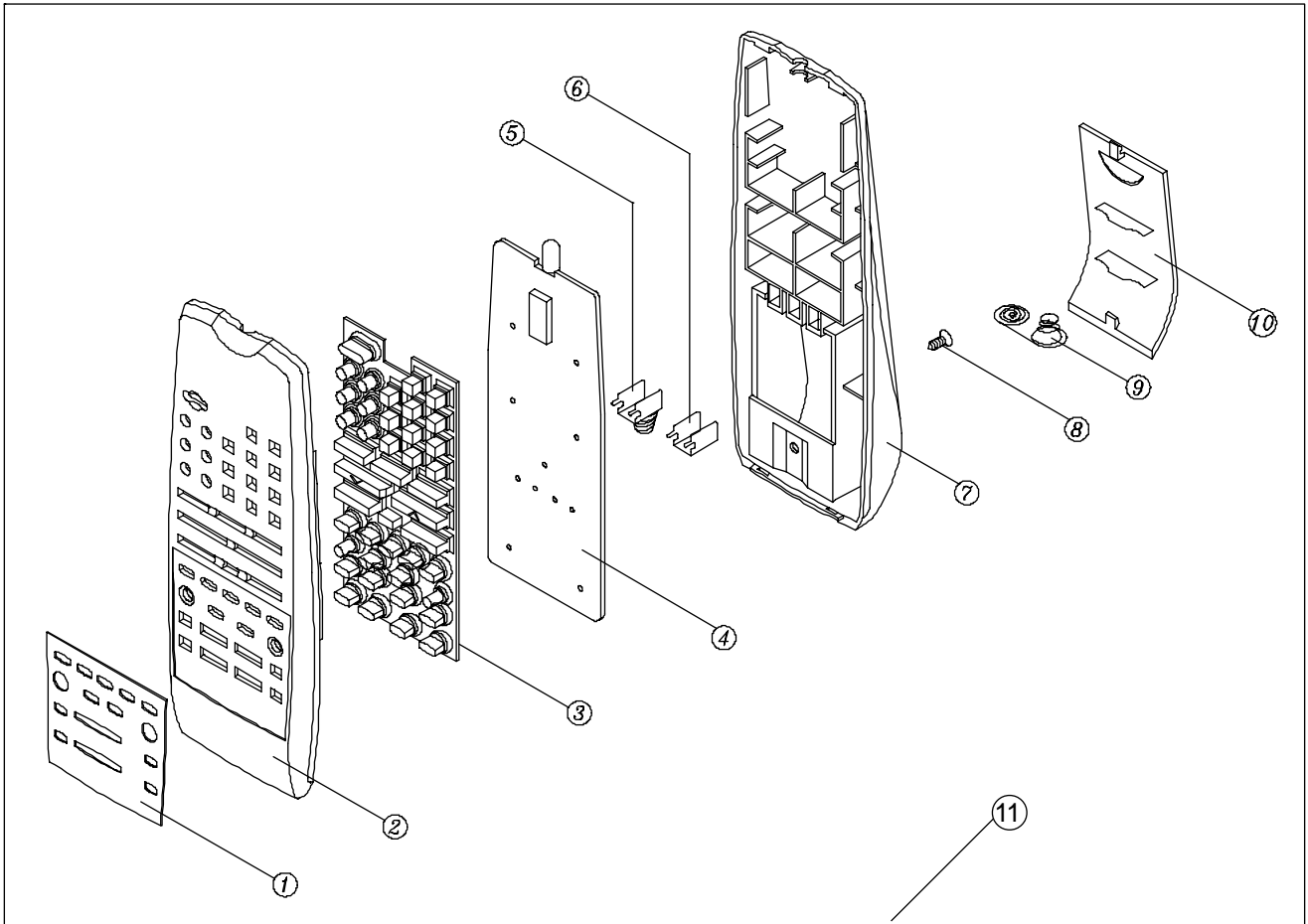

Location	Part No.	Discription	QTY
1	384-010101-11H	REMOTE OVERLAY	1
2	201-010111-22S	REMOTE CAB TOP	1
3	373-010101-03Y	REMOTE CONTATIVE RUBBER	1
4	090-385610-03	P.C.B. REMOTE BOARD	1
5	473-010101-01	BATT CONTACT SPRING SHEET-VE	1
6	472-010101-01	BATT CONTACT PLATE+VE	1
7	203-010131-03S	REMOTE CABINET BOTTOM	1
8	611-260206-10	SELF-TAPPING SCREW K/T 2.6x6mm	1
9	474-010101-01	BATT CONTACT SPRING WIRE	1
10	210-010101-03S	REMOTE BATTERY COVER +/- VE	1
11	790-010110-11	REMOTE CONTROL HANDSET (43 KEYS)	1



**D. Elec. Parts list**

**i. RESISTOR**

Location	Description	QTY
R22	RESISTOR CARBON 18 1/16W ±5%	1
R110	RESISTOR CARBON 100 1/16W ±5%	5
R112		
R509		
R713		
R715		
R710	RESISTOR CARBON 180 1/16W ±5%	1
R102	RESISTOR CARBON 1K 1/16W ±5%	2
R103		
R108	RESISTOR CARBON 3K3 1/16W ±5%	1
R501	RESISTOR CARBON 4K7 1/16W ±5%	3
R502		
R503		
R701	RESISTOR CARBON 5K6 1/16W ±5%	4
R702		
R722		
R723		
R700	RESISTOR CARBON 6K8 1/16W ±5%	6
R703		
R704		
R707		
R716		
R719		
R111	RESISTOR CARBON 10K 1/16W ±5%	13
R500		
R505		
R601		
R602		
R603		
R604		
R705		
R706		
R708		
R714		
R717		
R718		
R304	RESISTOR CARBON 15K 1/16W ±5%	1
R100	RESISTOR CARBON 22K 1/16W ±5%	8
R101		
R506		
R508		
R510		
R511		
R562		
R564		
R104	RESISTOR CARBON 24K 1/16W ±5%	2
R105		
R507	RESISTOR CARBON 33K 1/16W ±5%	1
R305	RESISTOR CARBON 39K 1/16W ±5%	1
R720	RESISTOR CARBON 47K 1/16W ±5%	4
R721		
R725		
R726		
R600	RESISTOR CARBON 56K 1/16W ±5%	1
R306	RESISTOR CARBON 68K 1/16W ±5%	3
R709		
R711		
R712	RESISTOR CARBON 100K 1/16W ±5%	2
R724		
R307	RESISTOR CARBON 220K 1/16W ±5%	1
R504	RESISTOR CARBON 470K 1/16W ±5%	1
R204	RESISTOR CARBON 100 1/4W ±5%	8
R205		
R209		
R210		
R219		
R221		
R408		
R409		
R220	RESISTOR CARBON 150 1/4W ±5%	1

R214	RESISTOR CARBON 180 1/4W ±5%	5
R215		
R216		
R217		
R218		
R208	RESISTOR CARBON 220 1/4W ±5%	1
R201	RESISTOR CARBON 560 1/4W ±5%	2
R203		
R200	RESISTOR CARBON 680 1/4W ±5%	2
R202		
R207	RESISTOR CARBON 1K 1/4W ±5%	3
R405		
R406		
R404	RESISTOR CARBON 3K3 1/4W ±5%	2
R407		
R400	RESISTOR CARBON 4K7 1/4W ±5%	2
R402		
R212	RESISTOR CARBON 10K 1/4W ±5%	3
R213		
R410		
R206	RESISTOR CARBON 33K 1/4W ±5%	2
R211		
R401	RESISTOR CARBON 100K 1/4W ±5%	2
R403		
R300	RESISTOR CARBON 4.7 1W ±5%	4
R301		
R302		
R303		
R107	RESISTOR CARBON 100 3W ±5%	1
R106	RESISTOR CARBON 470 3W ±5%	1
R512	RESISTOR 4K7 ±5% 9PIN	2
R513		

**ii. CAPACITOR**

Location	Description	QTY
C504	CAPACITOR CERAMIC 30PF/50V ±20%	2
C505		
C202	CAPACITOR CERAMIC 47PF/50V ±20%	1
C406	CAPACITOR CERAMIC 100PF/50V ±20%	5
C407		
C502		
C715		
C729		
C104	CAPACITOR CERAMIC 330PF/50V ±20%	2
C105		
C304	CAPACITOR CERAMIC 102PF/50V ±20%	3
C305		
C730		
C108	CAPACITOR CERAMIC 103PF/50V ±20%	13
C109		
C110		
C111		
C126		
C127		
C128		
C129		
C130		
C131		
C132		
C133		
C501		
C200	CAPACITOR CERAMIC 223PF/50V ±20%	2
C201		
C713	CAPACITOR CERAMIC 272/50V ±20%	2
C714		
C124	CAPACITOR CERAMIC 104/50V ±20%	22
C125		
C134		
C135		
C137		
C138		
C203		
C205		

				iii. DIODE.TRANSISTOR		
				Location	Description	QTY
C206				VD111	DIODE IN4148	9
C301				VD206		
C302				VD207		
C409				VD403		
C506				VD500		
C507				VD600		
C508				VD601		
C710				VD602		
C711				VD603		
C716				VD110	DIODE IN4001	2
C721				VD300		
C722				VD100	DIODE IN4007	13
C723				VD101		
C724				VD102		
C100	CAPACITOR ELEC 4.7uF/16V ±20%	2		VD103		
C101				VD104		
C400	CAPACITOR ELEC 10uF/16V ±20%	22		VD105		
C401				VD106		
C402				VD107		
C405				VD108		
C503				VD109		
C700				VD114		
C701				VD115		
C702				VD400		
C703				VD200	DIODE LED F3 YELLOW	3
C704				VD202		
C705				VD204		
C706				VD201	DIODE LED F3 GREEN	3
C707				VD203		
C708				VD205		
C709				VD402	DIODE ZENER 5V1 0.5W	1
C720				VD112	DIODE ZENER 12V 1W	1
C725				VD401	DIODE ZENER 22V 1W	1
C726				VD113	DIODE BRIDGE BF40C6A	1
C727				V100	TRANSISTOR C9014 β≥250	7
C728				V101		
C731				V200		
C732				V201		
C718	CAPACITOR ELEC 22uF/16V ±20%	1		V202		
C113	CAPACITOR ELEC 100uF/16V ±20%	9		V502		
C114				V503		
C118				V301	TRANSISTOR C1815 β≥250	2
C204				V302		
C403				V300	TRANSISTOR A1015 β≥250	1
C404				V102	TRANSISTOR 2N5401 β≥250	1
C500				N100	TRANSISTOR ZENER L7805CV	2
C509				N104		
C717				N101	TRANSISTOR ZENER L7808CV	1
C116	CAPACITOR ELEC 220uF/16V ±20%	1		N103	TRANSISTOR ZENER L7812CV	1
C119	CAPACITOR ELEC 470uF/16V ±20%	1				
C121	CAPACITOR ELEC 1000uF/16V ±20%	3				
C122						
C123						
C136	CAPACITOR ELEC 10uF/25V ±20%	1				
C102	CAPACITOR ELEC 47uF/25V ±20%	2				
C103						
C117	CAPACITOR ELEC 100uF/25V ±20%	1				
C112	CAPACITOR ELEC 220uF/25V ±20%	3				
C115						
C303						
C120	CAPACITOR ELEC 1000uF/25V ±20%	1				
C408	CAPACITOR ELEC 220uF/35V ±20%	1				
C106	CAPACITOR ELEC 2200uF/35V ±20%	2				
C107						
C712	CAPACITOR ELEC 2.2uF/50V ±20%	2				
C719						
C300	CAP H-VOLTAGE MKP-0.15K/275V ±20%	1				
				iv. IC		
				Location	Description	QTY
				N400	IC, JRC4558	4
				N502		
				N700		
				N701		
				N600	IC, PT16311	1
				N702	IC, PT2314	1
				N102	IC, LM1876TF	1
				N601	IC, HT24C02	1
				N500	IC, CPU(89C58)	1

v. OTHERS

Location	Description	QTY
RP200	ENCODER VOLUME	1PCS
L700	INDUCTANCE 1.8UH	1PCS
L300	COIL INDUCTANCE 3UH	1PCS
L301	COIL INDUCTANCE 1UH	2PCS
L302		
X500	CRYSTAL 12MHZ	1PCS
IR200	REMOTE SENSOR 1838	1PCS
VFD600	VFD 25100-3A08	1PCS
XS700	RCA SOCKET AV6-8.4-7	1PCS
XS300	JACK SPK WP4-15	1PCS
P202	JACK HEADPHONE 7PIN	1PCS
RL100	RELAY YL-202 (DC12V)	1PCS
RL300		
F100	FUSE F3.15A/250V	1PCS
F101		
F300	FUSE T4A/250V	1PCS
F100	FUSE HOLD	2PAIR
F101		
F300	FUSE HOLD	1PCS
P300	AC LINE CORD 1.8M	1PCS
K200	SWITCH TACT 6x6x9.5	10PCS
K201		
K202		
K600		
K601		
K602		
K603		
K604		
K605		
K606		
	AV LINE (RED, WHITE, YELLOW) L=1.2M	1PCS
	FM ANTENNA 1.8M	1PCS
	AM ANTENNA	1PCS
	CONNECTOR WIRE (See attachment 1)	1SET

(Attachment 1)

