

Service Manual

Stereo Cassette Deck

Cassette Deck

RS-BX501

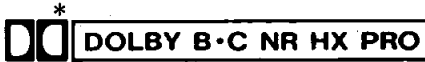

Colour

(K) ... Black Type

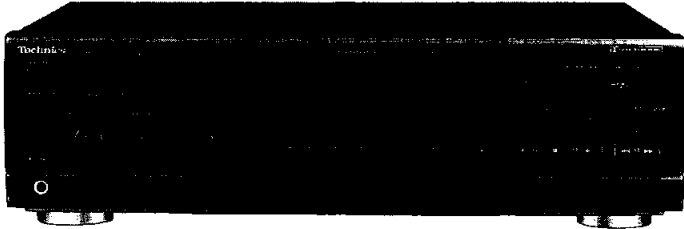

Area

Suffix for Model No.	Area	Colour
(E)	Europe.	(K)
(EB)	Great Britain.	
(EG)	Germany and Italy.	

* Dolby noise reduction and HX PRO headroom extension manufactured under license from Dolby Laboratories Licensing Corporation. HX PRO originated by Bang and Olufsen. "Dolby", the double-D symbol, and "HX PRO" are trademarks of Dolby Laboratories Licensing Corporation.

RFKV0013 Capstan Mod

12.

AR-1 MECHANISM SERIES

SPECIFICATIONS

■ CASSETTE DECK SECTION

Deck system	Stereo cassette deck
Track system	4-track, 2-channel
Recording system	AC bias
Bias frequency	80 kHz
Erasing system	AC erase
Heads	Recording/Playback head (Permalloy)×1 Erasing head (Double-gap ferrite)×1
Motors	Capstan drive (DC servo motor)×1 Reel table drive (DC motor)×1
Tape speed	4.8 cm/sec. (1 $\frac{7}{8}$ ips)
Wow and flutter	0.07% (WRMS) ±0.2% (DIN)
Fast forward and rewind times	Approx. 50 seconds with C-60 cassette tape
Frequency response (Dolby NR off)	
NORMAL	30 Hz–15 kHz, ±3 dB 30 Hz–16 kHz (DIN)
CrO ₂	30 Hz–15 kHz, ±3 dB 30 Hz–16 kHz (DIN)
METAL	30 Hz–16 kHz, ±3 dB 30 Hz–17 kHz (DIN)

S/N (Signal level=max recording level, CrO₂ type tape)

NR off	56 dB (A weighted)
Dolby B NR on	66 dB (A weighted)
Dolby C NR on	74 dB (A weighted)

Input sensitivity and impedance

REC (IN)	100 mV/47 kΩ
----------	--------------

Output voltage and impedance

PLAY (OUT)	500 mV/500Ω
------------	-------------

HEADPHONES

	190 mV/(8Ω) (Load impedance 8Ω–600Ω)
--	---

■ GENERAL

Power consumption	19 W
Power supply	AC 50 Hz/60 Hz, 230 V–240 V
Dimensions (W×H×D)	430×125×293 mm
Weight	3.8 kg

Note:

Design and specifications are subject to change without notice.
Weight and dimensions are approximate.

Technics

CONTENTS

	Page
CAUTION FOR AC MAINS LEAD	2
FRONT PANEL CONTROLS	3
ACCESSORIES	4
CONNECTIONS	4
PLAYBACK	5, 6
TO FAST-FORWARD OR REWIND THE TAPE	6
ABOUT THE ATC FUNCTION	7
SELF-DIAGNOSTIC	8
DISASSEMBLY INSTRUCTIONS	9~18
WRITING TO EEPROM	19~21
MEASUREMENTS AND ADJUSTMENTS	22~24
TROUBLESHOOTING GUIDE	25~29

CAUTION FOR AC MAINS LEAD

For (EB) area only

For your safety, please read the following text carefully.

This appliance is supplied with a moulded three pin mains plug for your safety and convenience.

A 5-ampere fuse is fitted in this plug.

Should the fuse need to be replaced please ensure that the replacement fuse has a rating of 5-ampere and that it is approved by ASTA or BSI to BS1362.

Check for the ASTA mark  or the BSI mark  on the body of the fuse.

If the plug contains a removable fuse cover you must ensure that it is refitted when the fuse is replaced.

If you lose the fuse cover the plug must not be used until a replacement cover is obtained.

A replacement fuse cover can be purchased from your local dealer.

CAUTION!

IF THE FITTED MOULDED PLUG IS UNSUITABLE FOR THE SOCKET OUTLET IN YOUR HOME THEN THE FUSE SHOULD BE REMOVED AND THE PLUG CUT OFF AND DISPOSED OF SAFELY.

THERE IS A DANGER OF SEVERE ELECTRICAL SHOCK IF THE CUT OFF PLUG IS INSERTED INTO ANY 13-AMPERE SOCKET.

If a new plug is to be fitted please observe the wiring code as shown below.

If in any doubt please consult a qualified electrician.

IMPORTANT

The wires in this mains lead are coloured in accordance with the following code:

Blue: Neutral

Brown: Live

As the colours of the wires in the mains lead of this appliance may not correspond with the coloured markings identifying the terminals in your plug, proceed as follows:

The wire which is coloured BLUE must be connected to the terminal in the plug which is marked with the letter N or coloured BLACK.

	Page
BLOCK DIAGRAM	30~32
SCHEMATIC DIAGRAM	33~39
PRINTED CIRCUIT BOARDS	40~43
REPLACEMENT OF THE FOOT	43
WIRING CONNECTION DIAGRAM	44
TERMINAL FUNCTION OF IC	45~47
REPLACEMENT PARTS LIST	48, 53~55, 57
PACKAGING	48
CABINET PARTS LOCATION	49, 50
MECHANISM PARTS LOCATION	51, 52
RESISTORS AND CAPACITORS	56, 57

The wire which is coloured BROWN must be connected to the terminal in the plug which is marked with the letter L or coloured RED.

Under no circumstances should either of these wires be connected to the earth terminal of the three pin plug, marked with the letter E or the Earth Symbol \perp .

Before use

Remove the connector cover as follows.

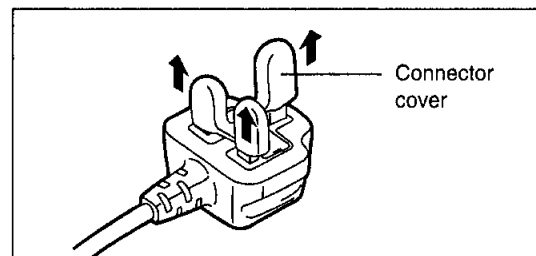

How to replace the fuse

1. Remove the fuse cover with a screwdriver.

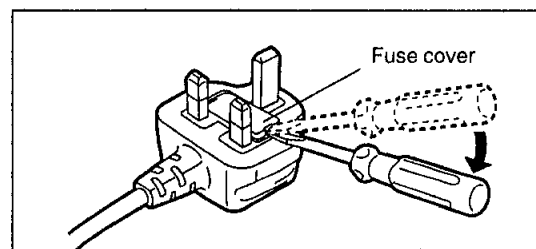

2. Replace the fuse and attach the fuse cover.

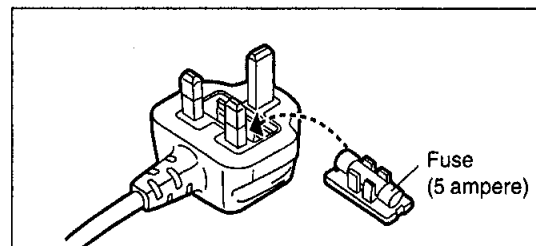

FRONT PANEL CONTROLS

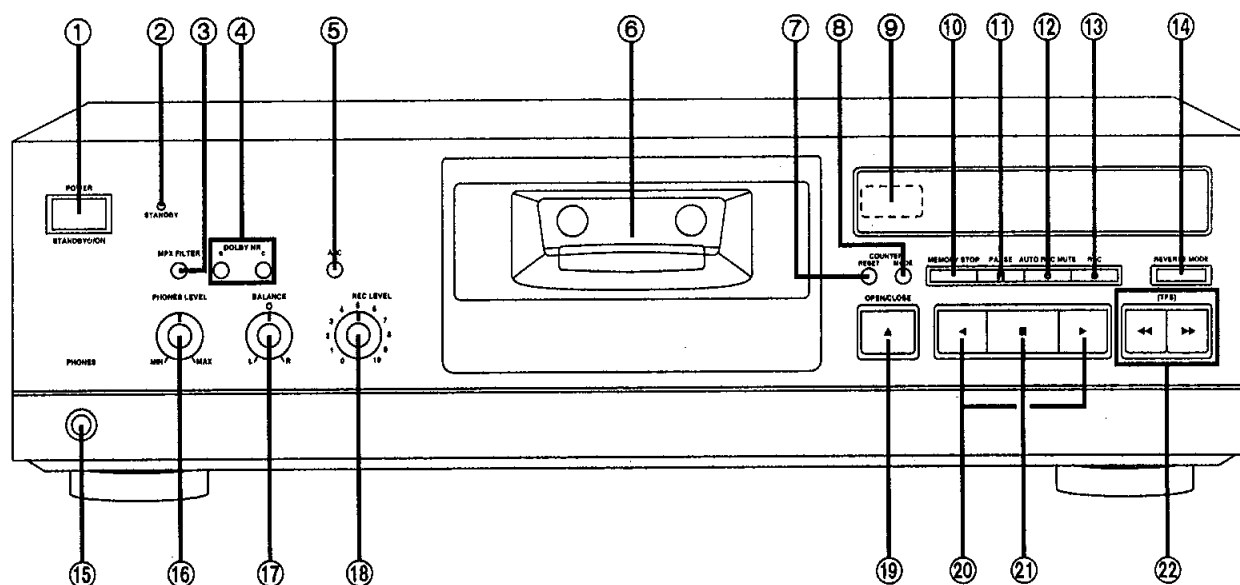

No.	Name
①	Power "STANDBY ⏻/ON" switch (POWER, STANDBY ⏻/ON) Press to switch the unit from on to standby mode or vice versa. In standby mode, the unit is still consuming a small amount of power.
②	Standby indicator (STANDBY) When the unit is connected to the AC mains supply, this indicator lights up in standby mode and goes out when the unit is turned on.
③	Multiplex filter button (MPX FILTER)
④	Dolby noise reduction buttons (DOLBY NR B, C)
⑤	Auto tape calibration button (ATC)
⑥	Cassette holder
⑦	Tape/linear counter reset button (COUNTER RESET)
⑧	Tape/linear counter mode button (COUNTER MODE)
⑨	Remote control signal sensor
⑩	Memory stop button (MEMORY STOP)
⑪	Pause button (II PAUSE)
⑫	Automatic record muting button (□ AUTO REC MUTE)

No.	Name
⑬	Record button (● REC)
⑭	Reverse-mode select button (REVERSE MODE)
⑮	Headphones jack (PHONES)
⑯	Headphones volume control (PHONES LEVEL)
⑰	Recording balance control (BALANCE)
⑱	Recording level control (REC LEVEL)
⑲	Cassette holder open/close button (▲ OPEN/CLOSE)
⑳	Playback buttons (◀/▶)
㉑	Stop button (■)
㉒	Rewind/fast-forward search buttons (◀◀/▶▶ [TPS])

ACCESSORIES

AC power supply cord 1 pc.
 (For (EB) area: VJA0733) (for others: RJA0019-2K)

Stereo connection cables (SJP2276) 2 pcs.

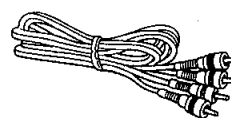
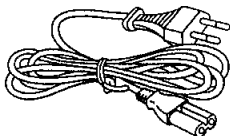
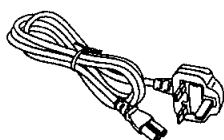

CONNECTIONS

Before making connections, make sure that the power to this unit and all other system components is turned off.

Note

- Avoid letting the cables touch each other as much as possible, otherwise noise will be generated.
- The configuration of the AC outlet and AC mains lead differ according to area.
- Although the figure below shows the AC power supply cord being connected to a household AC outlet, if the amplifier (or receiver) is equipped with an AC outlet, connect the cord to that outlet.

For (EB) area only
BE SURE TO READ THE CAUTION FOR AC MAINS LEAD ON PAGE 2 BEFORE THE FOLLOWING CONNECTIONS.

Placements hints

If this unit is placed near a receiver or a tuner, a "hum" noise may be heard during tape playback, recording, or AM reception of the receiver or the tuner.

If this occurs, leave as much space as possible between the units, or place them where there is the least amount of "hum".

Insertion of connector

Even when the connector is perfectly inserted, depending on the type of inlet used, the front part of the connector may jut out as shown in the drawing. However there is no problem using the unit.

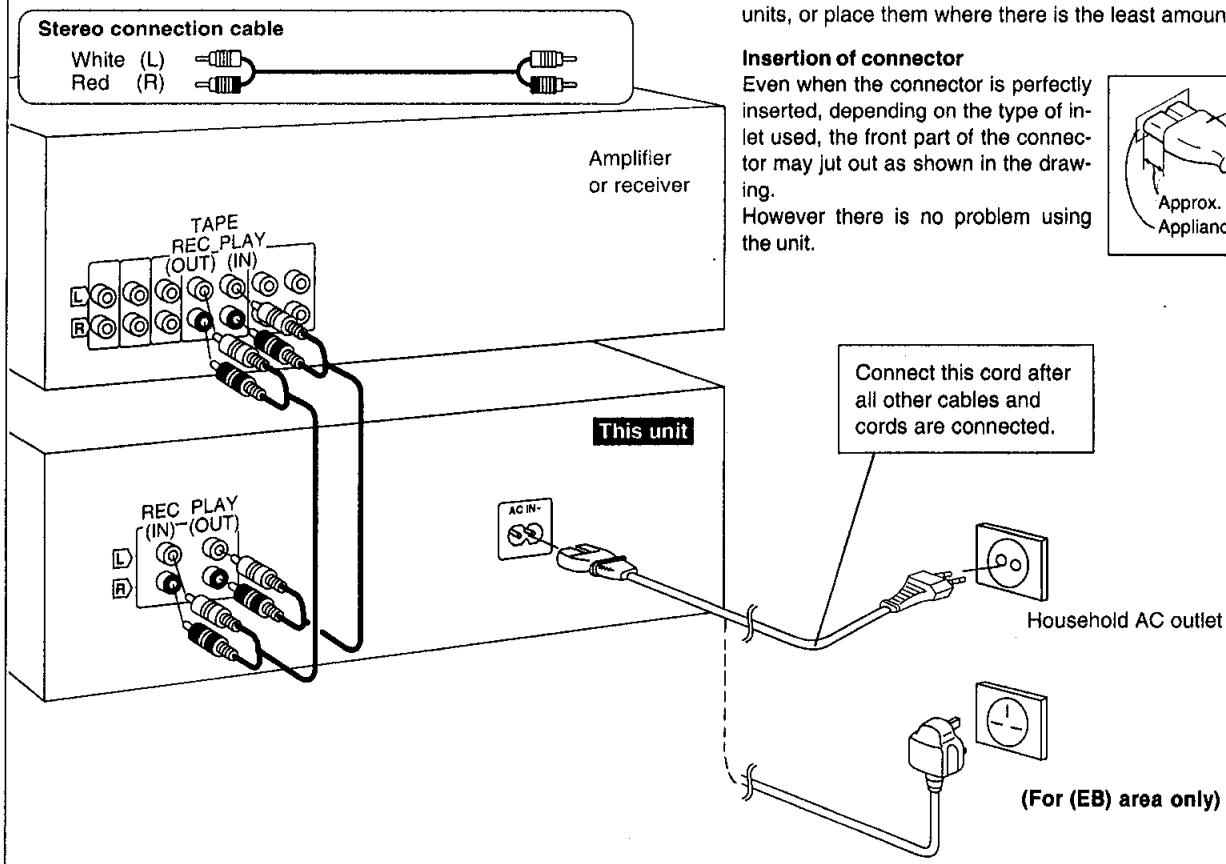
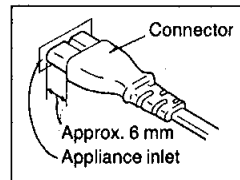

PLAYBACK

Either normal, CrO₂ or metal type cassettes can be used.

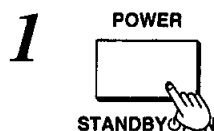
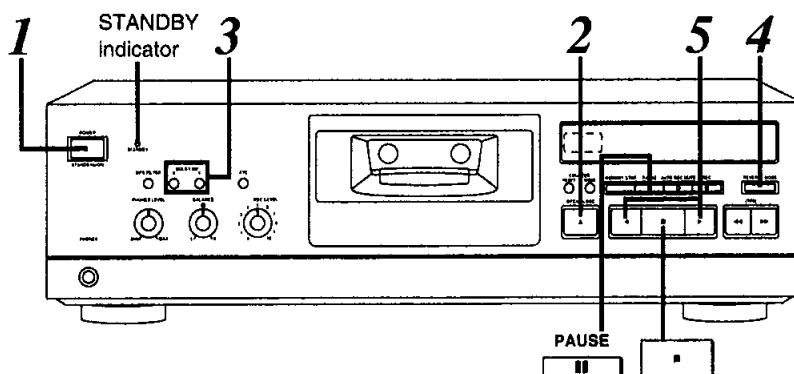

Press POWER.
(The unit will switch on.)
Standby indicator will go off.

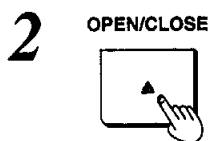

Press OPEN/CLOSE, and then insert the cassette tape.
Press again to close the cassette holder.

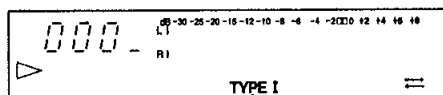
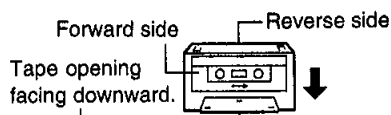

The tape type will be displayed.

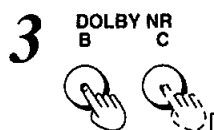

Press either DOLBY NR B or C to select the appropriate noise-reduction system.

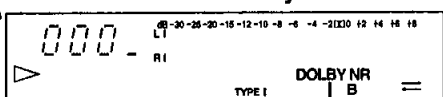

Illuminates

Select the same type as that used for recording. When playing back a tape which was not recorded using a Dolby NR system, press so that the indicators go off.

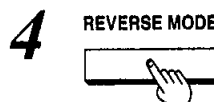

Press REVERSE MODE to select the appropriate reverse mode.

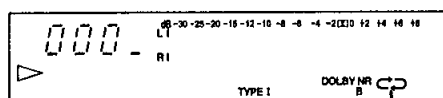

Each time the button is pressed, the indicator will change in the order:

⇄ : One side only.

↻ : Both sides repeatedly (up to 8 times).

(Refer to page 6.)



Press ► or ◀.
(Playback will begin.)
► : To begin from the forward side.
◀ : To begin from the reverse side.

Indicates the side being played.

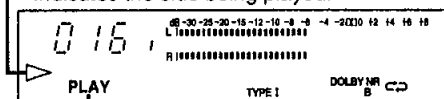

Illuminates

To temporarily stop playback

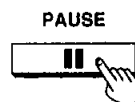

Press II.
The "PLAY" indicator will flash.

Press once again to resume playback.

To stop playback



Press ■.

For your reference:

When the cassette holder is open, pressing ◀, ►, ◀◀ or ►► will close the holder and begin the desired function.

About the automatic-tape-select function

This unit is equipped with the automatic-tape-select feature; it automatically detects the type of tape being used, and then makes the suitable adjustments of the bias and equalization accordingly.

The type of tape being used will be automatically detected and the indicator will illuminate.

TYPE I: NORMAL
TYPE II: CrO₂
TYPE IV: METAL

About the Dolby noise-reduction system

The Dolby noise-reduction system is designed to effectively reduce the annoying high-frequency "hissing" noise typical of cassette tapes. During recording, the system functions to increase the high-frequency sound level, the sound, and then, during playback, that same portion is weakened to bring it back to the previous level.

This unit includes two types of Dolby noise-reduction systems, the Dolby B NR-type and C NR-type.

Dolby B-type noise-reduction

Noise is reduced to about one-third.

Use this system when playing back tapes recorded by the Dolby-B noise-reduction system, such as prerecorded music tapes, etc.

Dolby C-type noise-reduction

Noise is reduced to about one-tenth.

Use this system for the recording and playback of sound sources that have a wide dynamic range and good tone quality, such as FM broadcasts of live performances, etc., and for playing back such tapes.

About the Dolby HX-Pro headroom extension system

By functioning to improve the maximum output level of the tape's high-frequency range, this system permits recordings without a reduction in the level of the sound source's high-frequency range. In addition, by using the system in parallel with this unit's noise-reduction system, recording and playback with a greatly extended dynamic range is possible.

Reverse function

The reverse function on this unit has two modes (↔, ⇄). Read the descriptions below and select the mode as desired. (Refer to step 4 on page 5.)

Mode	Tape travel
→ ←	Only one side of the tape (either the forward side or the reverse side) will be played, and operation will automatically stop when playback has been completed.
↔	Both sides of the tape will be played repeatedly eight times, and then operation will automatically stop. (If playback is begun from the reverse side, the forward side will be played seven times.)

TO FAST-FORWARD OR REWIND THE TAPE

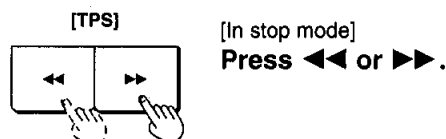
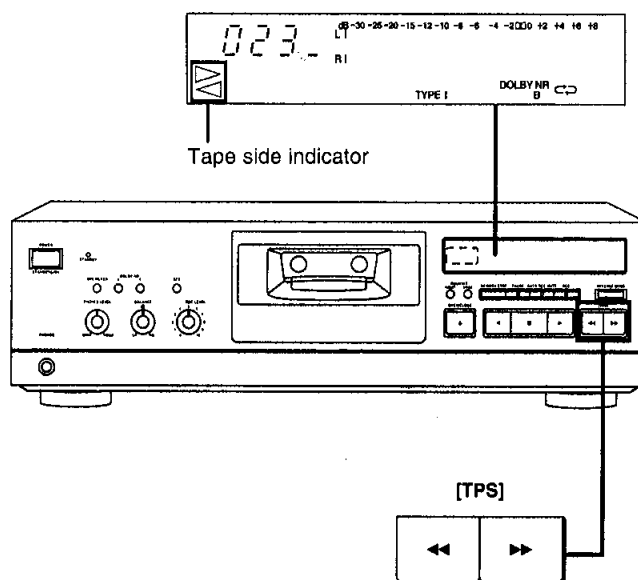

Because this unit is capable of playing back both sides of the tape, the operation changes in accordance with the direction of the tape side indicator.

Tape side Indicator	Rewind	Fast forward
▶	◀◀	▶▶
◀	▶▶	◀◀

High-speed tape transport

When fast-forwarding from near the beginning of the tape or when rewinding from near the end of the tape, the tape travel speed will be faster than that during normal fast-forwarding or rewind. (During high-speed tape transport, the **H** indication will light up.)

This high-speed tape transport will also function during TPS.

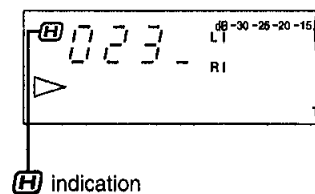

■ ABOUT THE ATC FUNCTION

The ATC (auto tape calibration) function records a test signal in order to automatically set the bias, equalizer and recording/playback level to the optimum recording conditions in accordance with the characteristics of the tape being used.

The table below shows the conditions of the display and the operation of the unit while the ATC settings are being made.

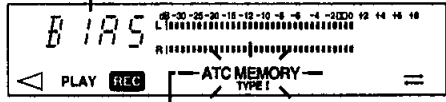
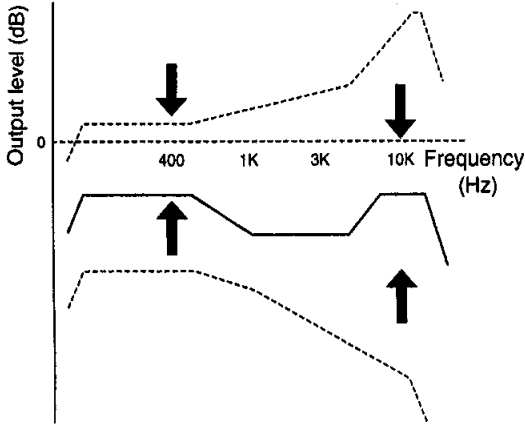
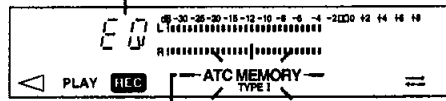
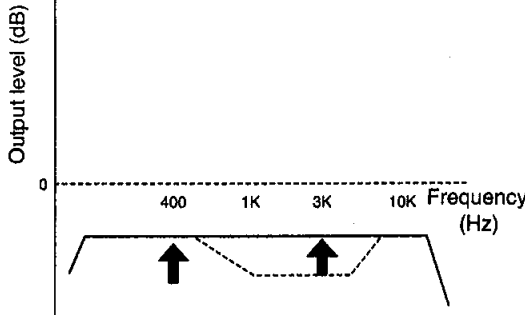
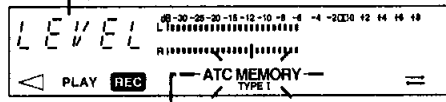
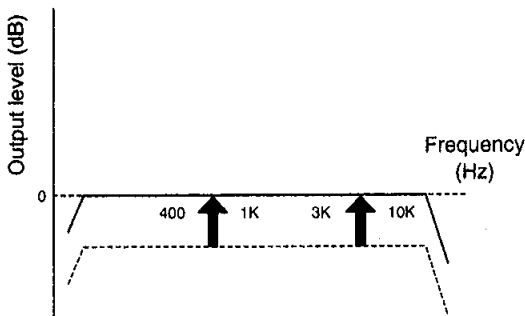
	Display	Unit operation
① Bias adjustment	<p>"BIAS" is displayed.</p>  <p>Flashes</p>	<p>The bias is adjusted so that the output level is the same at 400 Hz and at 10 kHz.</p> 
② Equalizer adjustment	<p>"EQ" is displayed.</p>  <p>Flashes</p>	 <p>The equalizer is adjusted so that the output level is the same at 400 Hz and at 3 kHz.</p>
③ Level adjustment	<p>"LEVEL" is displayed.</p>  <p>Flashes</p>	 <p>The tape sensitivity is compensated so that the recording input level and the playback output level are the same.</p>

■ SELF-DIAGNOSTIC

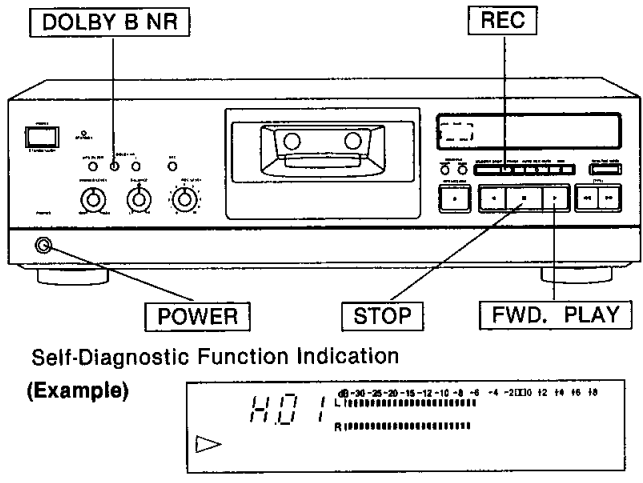
Indicating Procedure	Indicating Position
<p>To indicate Self-Diagnostic Function</p> <ol style="list-style-type: none"> 1. Check the cassette holder is empty (no cassette tape), then turn on the power. 2. Press and hold the DOLBY NR B button (for more than 3 seconds), and also press the STOP (■) button for about 2 seconds until the level meter changes from constantly lit to blinking. 3. Insert a normal blank cassette tape, either A or B side of which has the erase preventing piece folded. Then close the cassette holder. 4. Press the FWD. PLAY (▶) button and play the tape for more than 1 second, then press the STOP (■) button. 5. Insert a normal blank cassette tape, both A and B sides of which have the erase preventing pieces respectively, and close the cassette holder. (NOTE: Rewind the tape for 1 or 2 minutes before use.) 6. Press the REC (●) button. This automatically makes Deck perform the following operations. <p style="text-align: center;"> Record an eight second portion with no sound. → Record a 20 second portion off 400Hz test signal. When the signal is detected, stop the unit ← TPS-REVIEW search mode ← Stop the unit </p> <p>(NOTE: The tape has to be taken up by playback for about 1 minute.)</p> <ol style="list-style-type: none"> 7. To check the self-diagnostic results, press the STOP (■) button. These results are indicated in the respective displays. 8. If there is no fault, the counter display remains unchanged when the STOP (■) button is pressed. <p>To resume Ordinary Indication</p> <p>To return the display to normal mode, switch the power off and then back on again. To have the indication appear again, take the above-stated steps 1, 2 and 8.</p> <p>NOTE: The self-diagnostic results are stored in memory. To clear this memory, press and hold the STOP (■) button for at least 6 seconds until "CL" appears in the FL display. Be sure to clear the memory after the repair.</p>	 <p style="text-align: center;">Self-Diagnostic Function Indication (Example)</p> <p style="text-align: center;">▶ H01 00-20-25-20-15-12-10-8-6-4-2 0010 12 14 16 18</p>

Indication Text

Symbol	Trouble	Remedy
H01	Irregular action of cassette mechanism. (Example) Pressing the FWD PLAY button results in REW PLAY action.	The cassette mechanism mode switch (S971) and plunger are defective. (Check and replace them.)
H02	No recording can be made, or the unit is placed in the recording mode though the erase preventing piece has been broken.	The erase preventing switch (S974, S975) contacts improperly, or there is a shortcircuit. (Check and replace the switch.)
H03	Pressing the PLAY (▶) button fails to play the tape. Pressing the PLAY (▶) button causes the motor to rotate though no cassette tape is in.	The cassette half detect switch (S972) contacts improperly, or there is a shortcircuit. (Check and replace the switch.)
H04	The cassette holder will not open or close when the OPEN/CLOSE (▲) button is pressed.	The cassette holder open/close detect switch (S853, S854) contacts improperly, or there is a shortcircuit. (Check and replace the switch.)
H05	Pressing the OPEN/CLOSE (▲) button causes the cassette holder to open after it has closed, and vice versa.	
H06	No treble is produced when a normal tape is played or recorded.	The auto tape select (CrO ₂) switch (S973) contacts improperly, or there is a shortcircuit. (Check and replace the switch.)
H07	Excessive treble is produced when a CrO ₂ /Metal tape is played, or the recorded treble is distorted and at a low level.	The automatic tape select (Metal) switch (S976) contacts improperly, or there is a shortcircuit. (Check and replace the switch.)
F01	When the PLAY (▶) button is pressed, the tape runs a little and stops soon.	The hall IC (IC971, 972) is defective and, as the result, reel pulse is out of order. (Check and replace the IC.)
F02	TPS dose not operate.	The PLAYBACK AMP IC (IC2) is defective. (Check and replace the IC.)

DISASSEMBLY INSTRUCTIONS

OPERATION CHECKS AND MAIN COMPONENT REPLACEMENT PROCEDURES

NOTE

1. This section describes procedures for checking the operation of the major printed circuit boards and replacing the main components.
2. For reassembly after operation checks or replacement, reverse the respective procedures. Special reassembly procedures are described only when required.
3. Select items from the following index when checks or replacement are required.
4. Illustrated screws are equivalent to actual size.
5. [] indicates parts No.

• Contents

	page.
1. Checking for the FL P.C.B.	10.
2. Checking for the operation P.C.B.	11.
3. Checking for the main P.C.B.	12,13.
4. Checking for the motor P.C.B.	13.
5. Replacement for the mechanism unit.	14.
6. Replacement for the head block (R/P) and pinch roller ass'y.	15,16.
7. Replacement for the belt, flywheel ass'y, reel motor and capstan motor.	16,17.
8. Replacement of the parts mounted on mechanism P.C.B. and the plunger.	17,18.
9. Replacement for the drive rack and friction gear.	18.

1. Common disassembly procedures (Follow this procedure prior to other disassembly.)

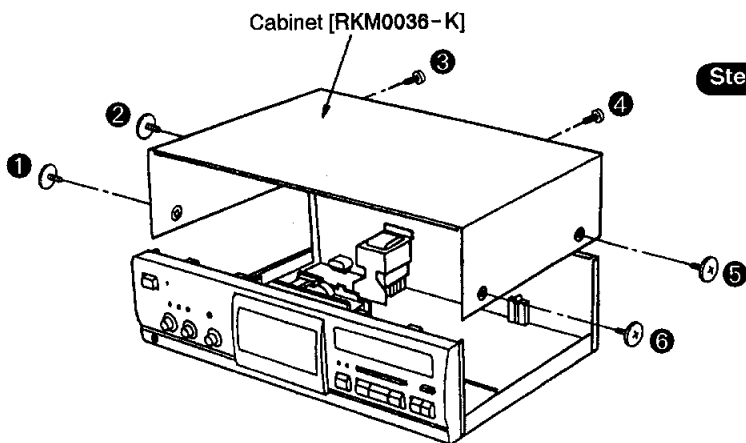

Step 1 Remove the 6 screws.

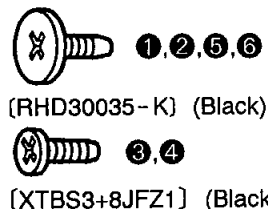

2. Checking for the FL P.C.B.

Step 1 Follow the disassembly procedure described in item 1 on page 9.

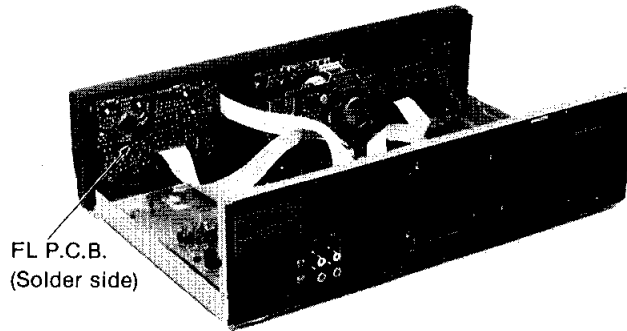

Step 2 Remove the connectors.

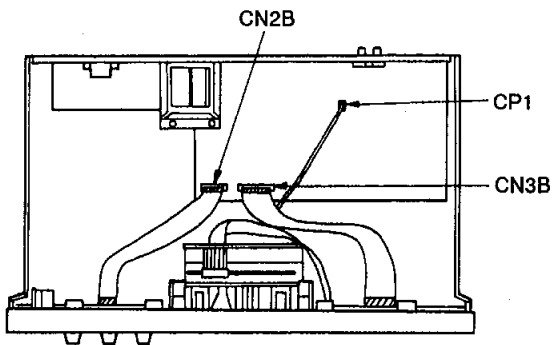

Step 3 Remove the 4 screws.

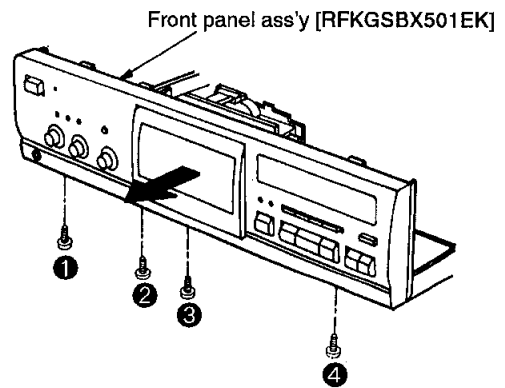

Step 4 Remove the 6 screws and connector.

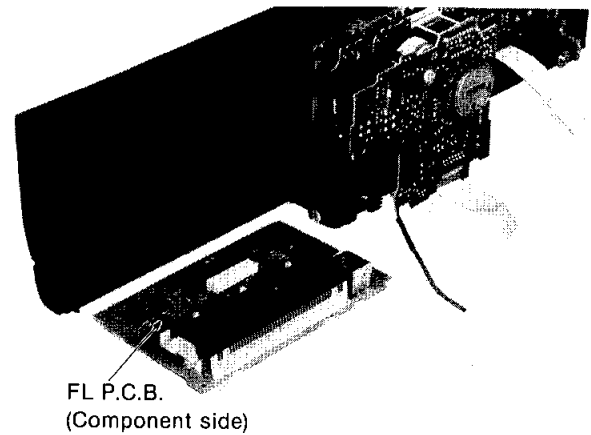
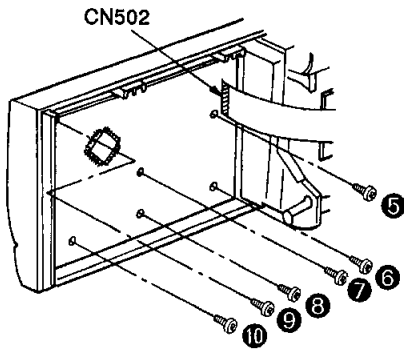

Removal of the FL meter

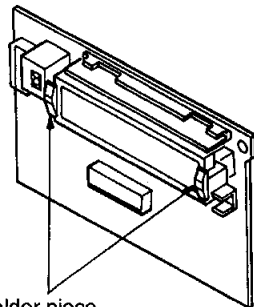

[XTBS3+8JFZ1] (Black)

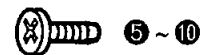

[XTBS26+8J]

3. Checking for the operation P.C.B.

Step 1 Follow the disassembly procedure described in item 1 on page 9.

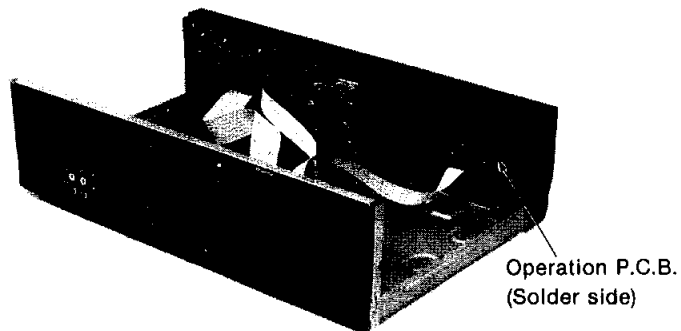

Step 2 Remove the connectors.

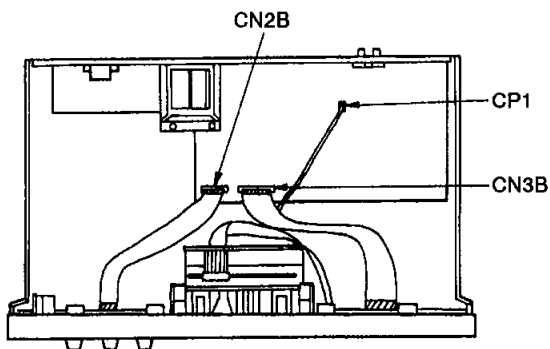

Step 3 Remove the 4 screws.

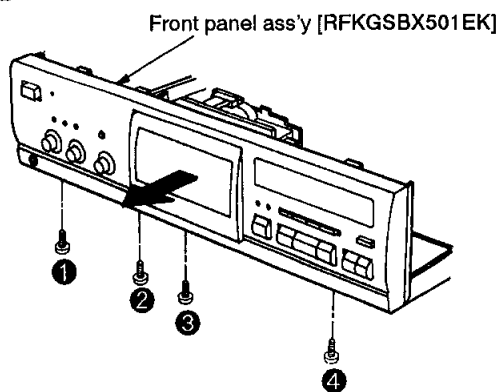

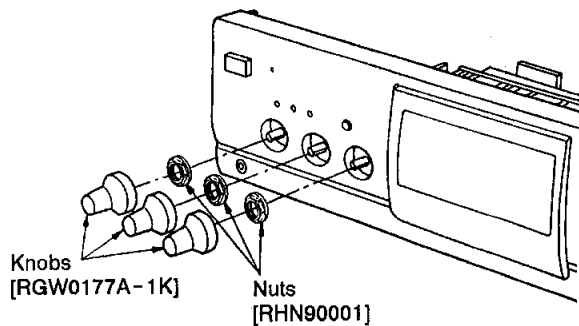

Step 4 Remove the knobs and nuts.

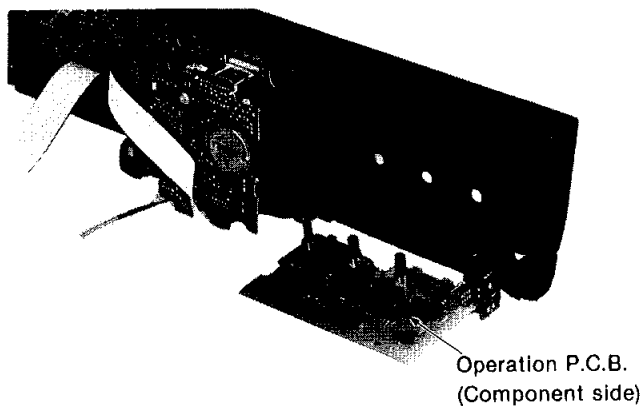
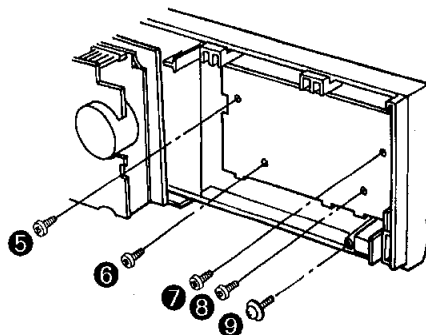

Step 5 Remove the 5 screws.



-  1 ~ 4
[XTBS3+8JFZ1] (Black)
-  5 ~ 8
[XTBS26+8J]
-  9
[RHD26016]

4. Checking for the main P.C.B.

Step 1 Follow the disassembly procedure described in item 1 on page 9.

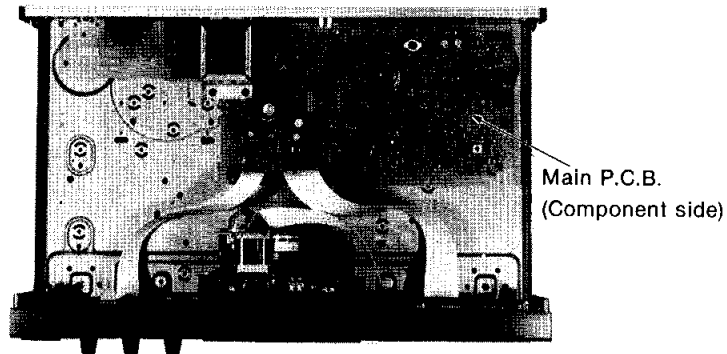

Step 2 Remove the 4 screws.

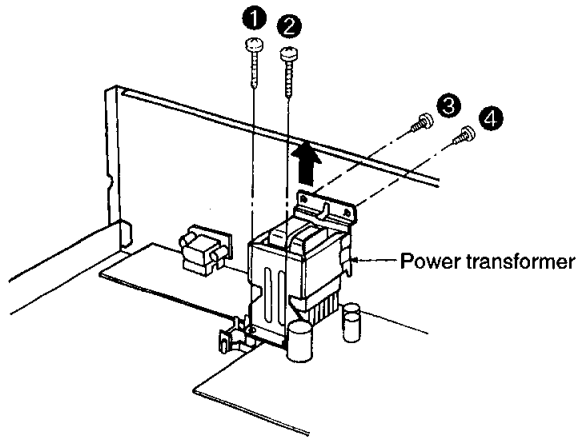

Step 3 Remove the 5 screws.

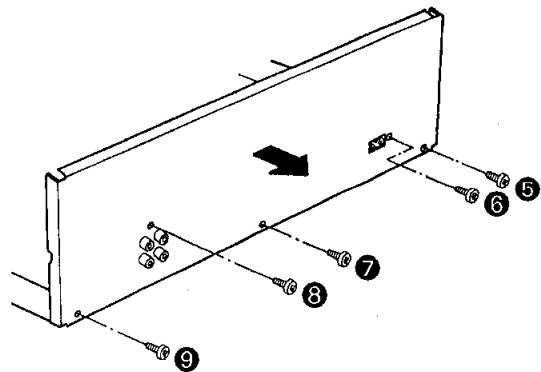

Step 4 Remove the 5 screws.

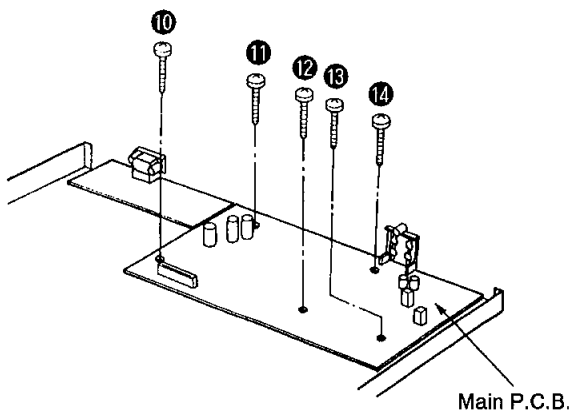

Step 5 Install the power transformer on the main P.C.B. and power supply P.C.B.

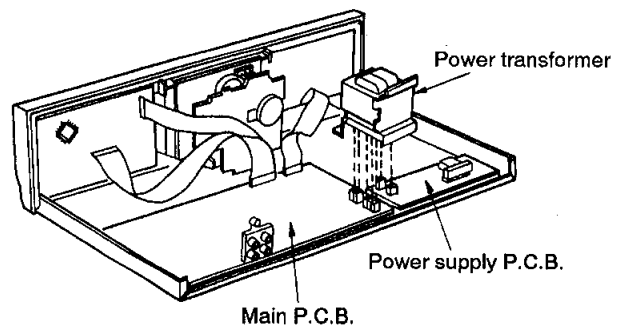

- | | |
|-----------------------|----------------|
| | 1, 2 |
| | 10 ~ 14 |
| [XTB3+20JFZ] (Black) | |
| | 3 ~ 9, 15 ~ 18 |
| [XTBS3+8JFZ1] (Black) | |

Step 6 Install the rear panel to the main P.C.B., power supply P.C.B. and power transformer with 4 screws.

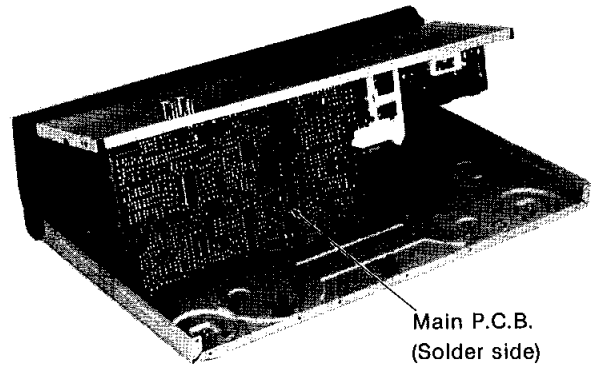
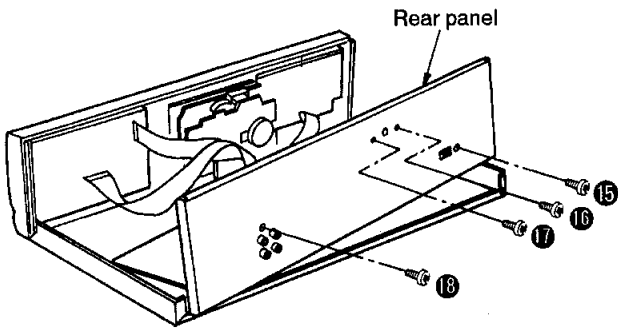

5. Checking for the motor P.C.B.

Step 1 Follow the disassembly procedure described in item 1 on page 9.

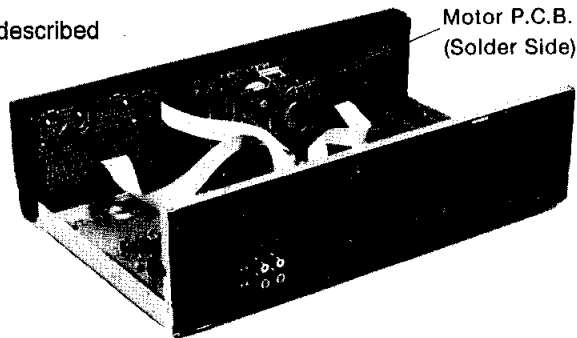

Step 2 Remove the connectors.

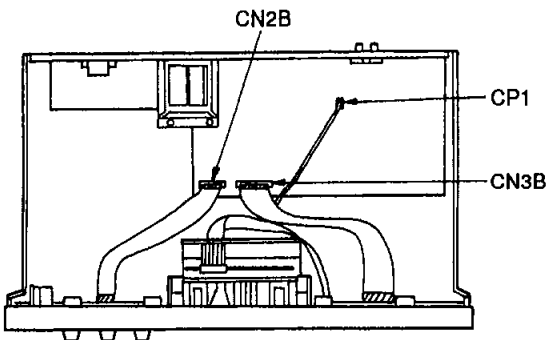

Step 3 Remove the 4 screws.

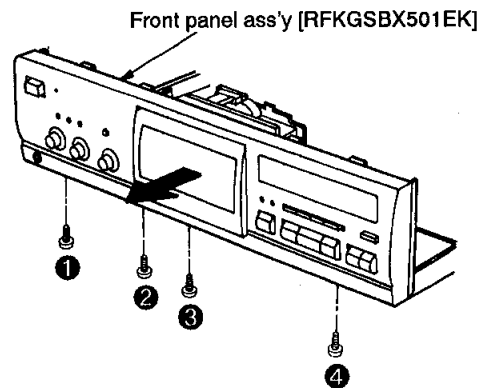

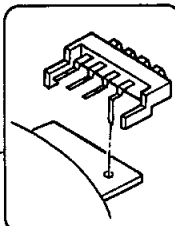
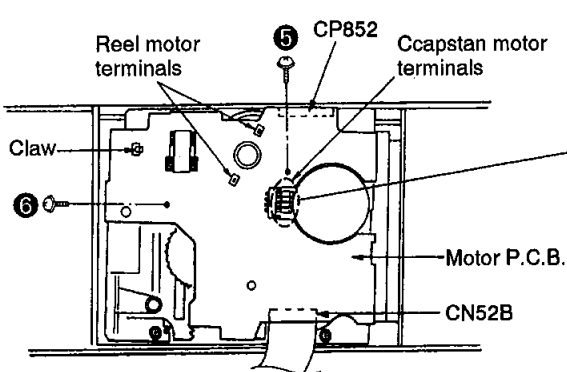

Step 4 Unsolder the reel motor and capstan motor terminals.

Step 5 Remove the 2 screws, claw and connectors.



NOTE

Handle the connector with care so that the shape of terminal is different from others.

-  1 ~ 4
[XTBS3+8JFZ1] (Black)
-  5, 6
[XTW2+6S] (Black)

6. Replacement for the mechanism unit

Step 1 Follow the disassembly procedure described in item 1 on page 9.

Step 2 Remove the connectors.

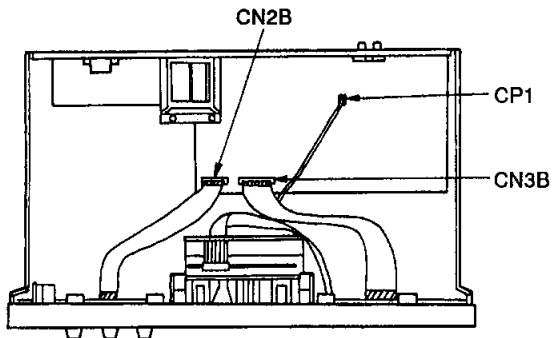

Step 4 Push the drive lever and open the cassette holder ass'y.

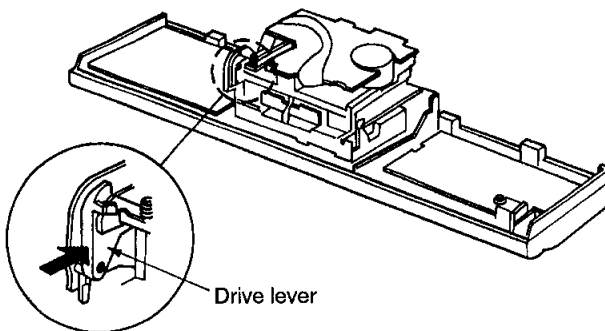

Step 3 Remove the 4 screws.

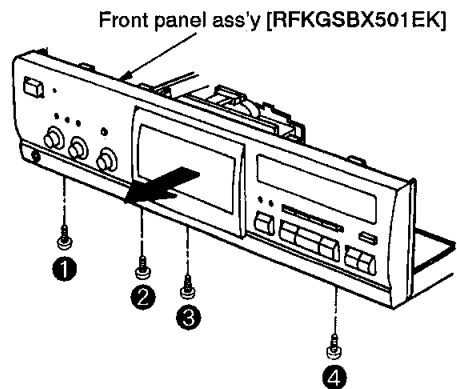

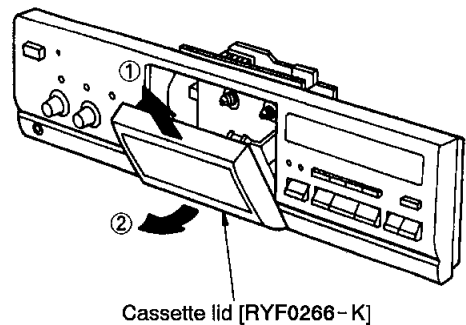

Step 5 Lift the cassette lid in the direction of arrow ①, and remove it in the direction of arrow ②.

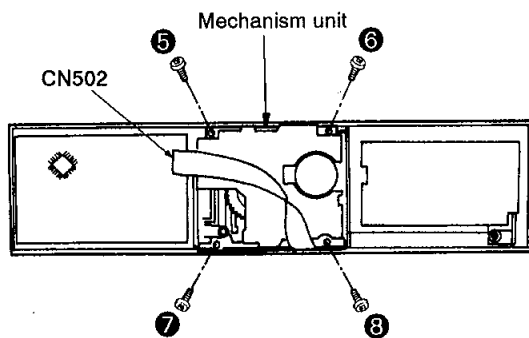

Step 6 Remove the 4 screws and connector.



-  ① ~ ④
[XTBS3+8JFZ1] (Black)
-  ⑤ ~ ⑧
[XTB3+12JFZ] (Black)

7. Replacement for the head block(R/P) and pinch roller ass'y

Step 1 Follow the disassembly procedure described in item 6 on page 14.

Step 2 Pull out the rivet in the direction of arrow ②, while pressing the claw in the direction of arrow ①.

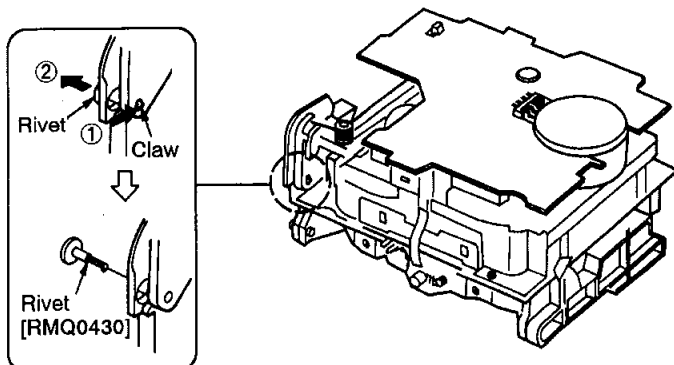

Step 3 Push the drive lever and open the cassette holder ass'y.

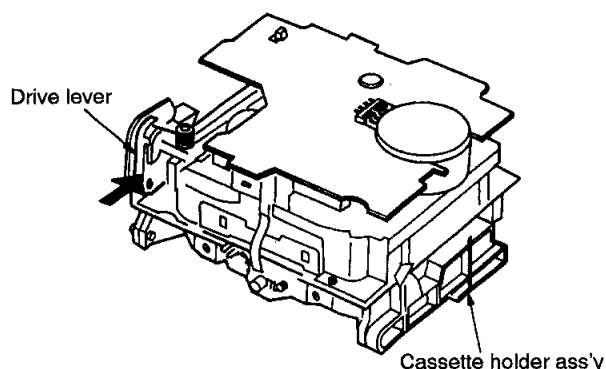

Step 4 Operate the cassette holder ass'y in the direction of arrow, and then remove it from the boss of drive lever.

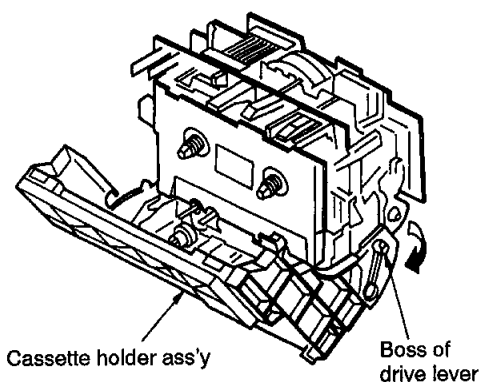

Step 5 Locate the cassette holder ass'y and mechanism unit at a 90 degree angle as shown below, and then pull the cassette holder ass'y.

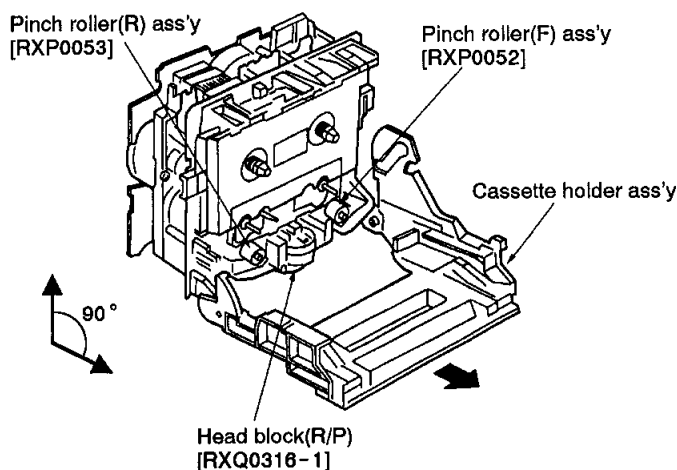

Installation of the cassette holder ass'y after replacement

Step 6 Locate the cassette holder ass'y and mechanism unit at a 90 degree angle, and then install the cassette holder ass'y.

Step 7 Push the drive rack in the direction of arrow.

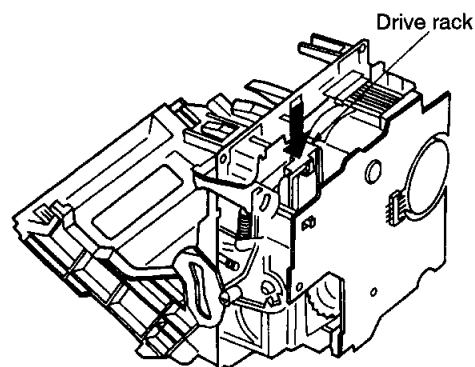
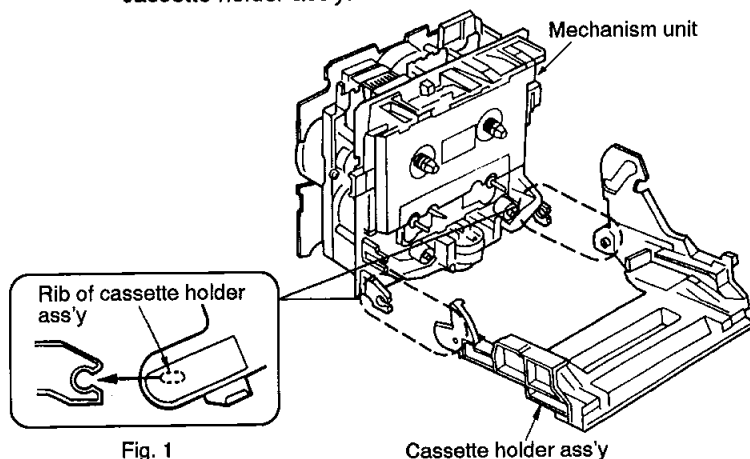

Step 8 Close the cassette holder ass'y in the direction of arrow.

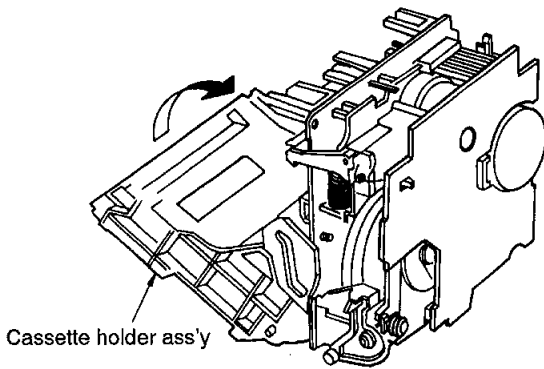

Step 9 Insert the rivet to the hole of cassette holder ass'y.

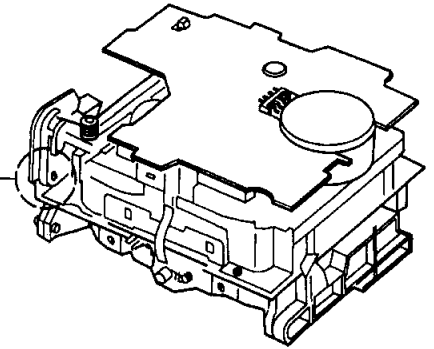
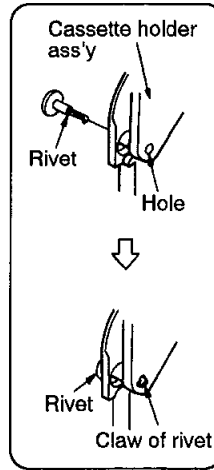

8. Replacement for the belt, flywheel ass'y, reel motor and capstan motor

Step 1 Perform the **Step 1 ~ Step 5** in item 7 on page 15.

Step 2 Push the drive rack in the direction of arrow ①.

Step 3 Remove the 4 screws and connector holder.

Step 4 Remove the sub chassis ass'y.

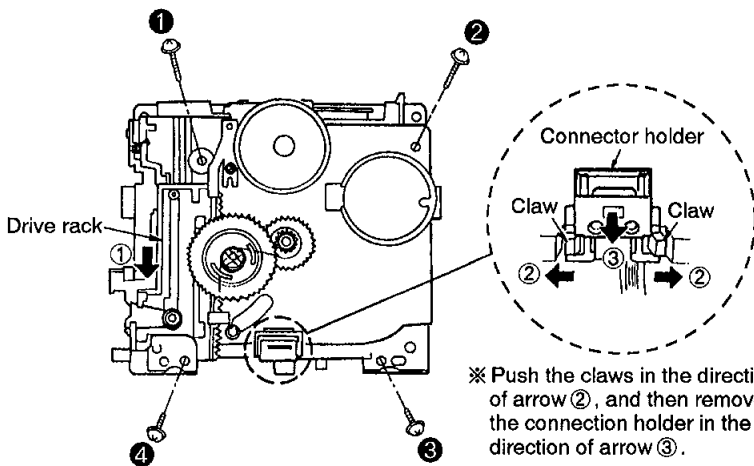

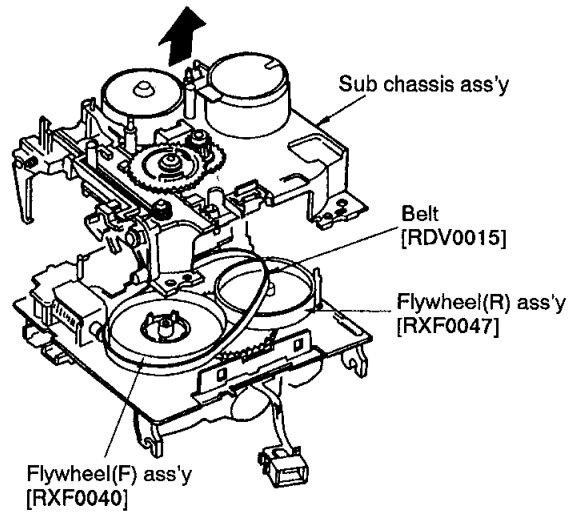

※ Push the claws in the direction of arrow ②, and then remove the connection holder in the direction of arrow ③.

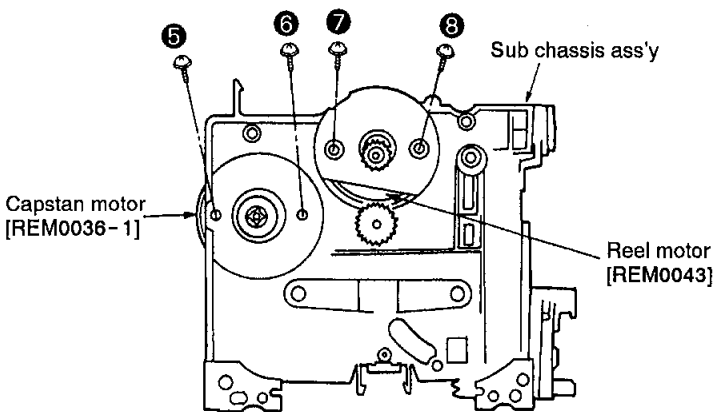

Step 5 Remove the 4 screws.

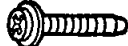

-  ①, ②
[XTW26+12S]
-  ③, ④
[XTW26+6L]
-  ⑤ ~ ⑧
[RHD26013]

Installation of the sub chassis ass'y after replacement

Step 6 Place the idler gear in the center as shown below.

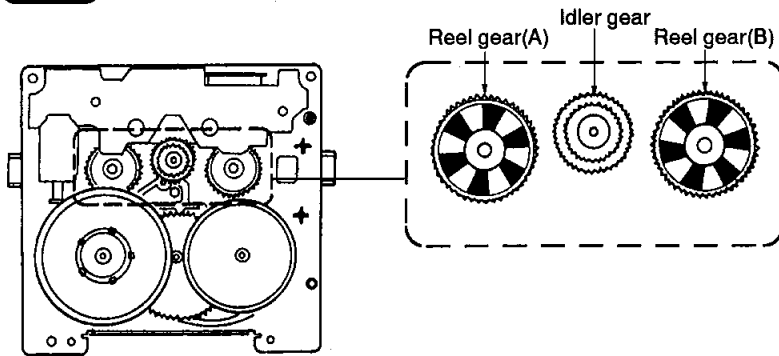

Step 7 Temporarily seure the belt as shown below.

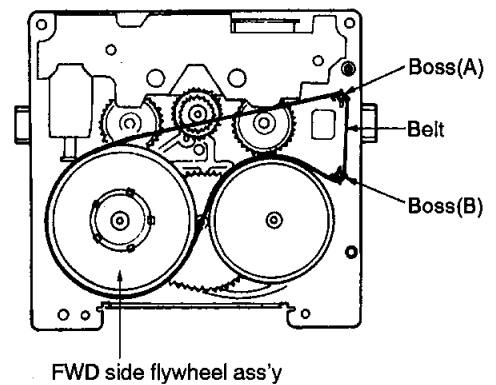

Step 8 Push the drive rack in the direction of arrow.

Step 9 Install the sub chassis ass'y to the chassis ass'y with 4 screws.

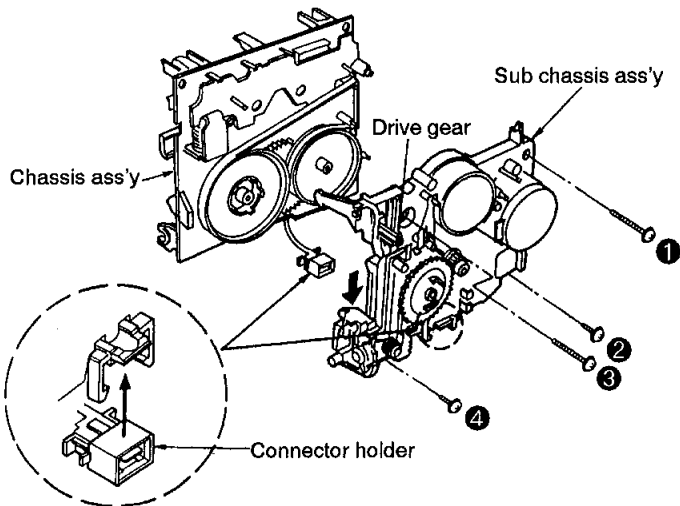

Step 10 Secure the belt with the capstan motor pulley.

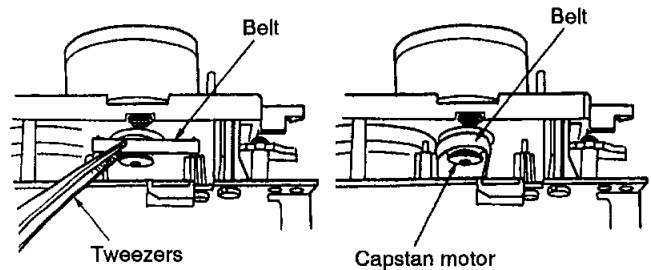

9. Replacement of the parts mounted on mechanism P.C.B. and plunger

Step 1 Perform the **Step 1** ~ **Step 4** in item 8 on page 16.

Step 2 Remove the 2 screws, and unsolder the terminals (2 points), and then remove the mechanism P.C.B.

Step 3 Release the 4 claws, and then remove the dressing plate.

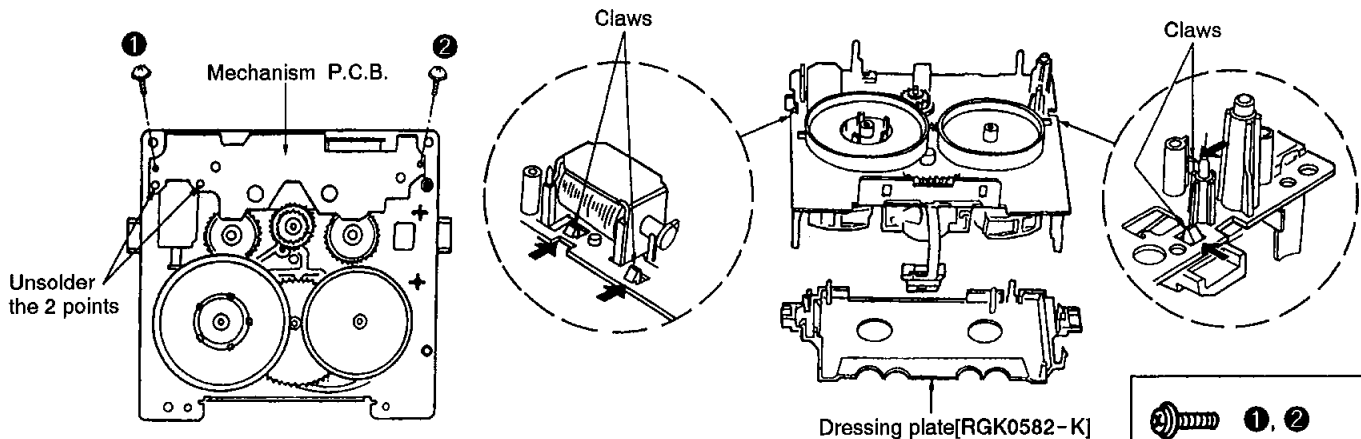

[XTW2+6S]

Step 4 Release the 4 claws.

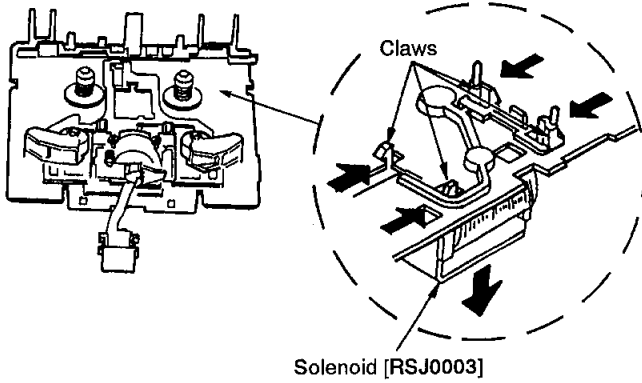

NOTE

Notice for installing solenoid.

- The shaft of solenoid should be aligned with the slot of lever.

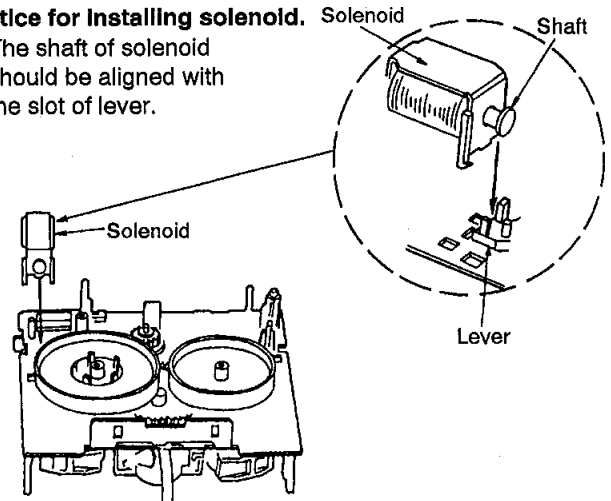

10. Replacement for the drive rack and friction gear ass'y

Step 1 Perform the **Step 1** ~ **Step 4** in item 8 on page 16.

Step 2 Remove the friction gear ass'y.

Friction gear ass'y [RXG0037]

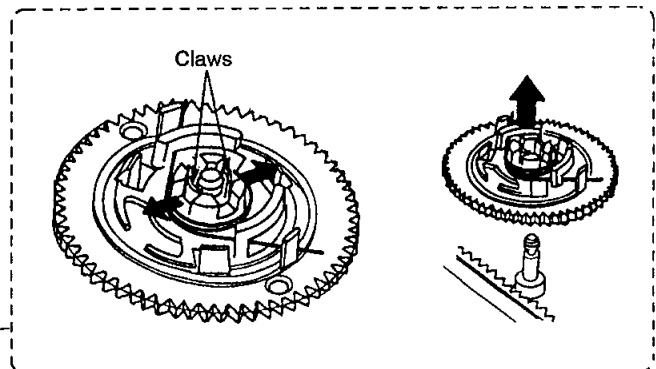
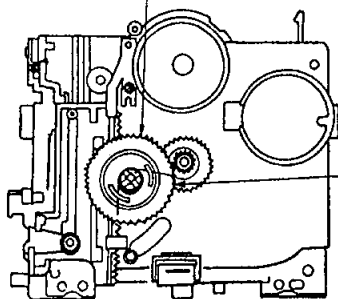

Step 3 Remove the screw and shield plate.

Step 4 Force the drive rack in the direction of arrow.

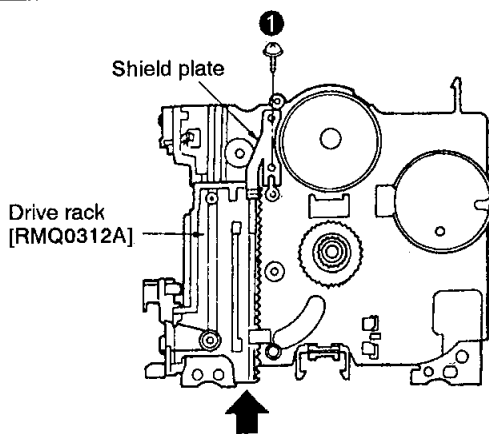

Step 5 Remove the drive rack using the screwdriver inserted into the hole.

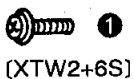
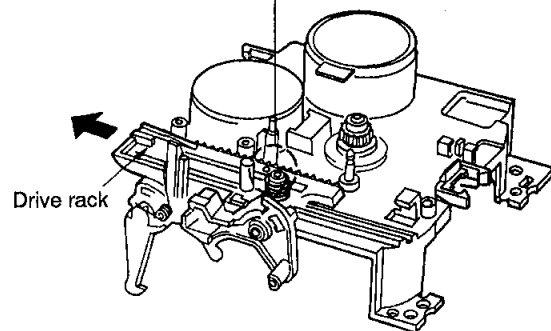
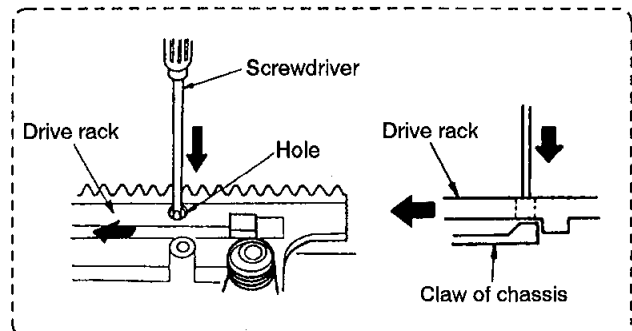

■ WRITING TO EEPROM

This unit is equipped with EEPROM memory that stores a variety of design data and performance data such as playback gain, bias value, recording gain, recording equalization, etc., which was programmed at the factory.

This EEPROM memory is capable of being read and written to more than 100,000 times. To illustrate this, if one ATC operation is performed every hour continuously every day for ten years, it would still be possible to successfully read and write with the EEPROM.

Data is actually written in this EEPROM only when ATC is actuated or when power supply is turned on or off. Since it hardly breaks down, there will scarcely occur such a trouble as to require replacement.

Measurement Condition

- Recording-level control; Maximum
- Recording-balance control; Center
- Reverse-mode selector switch; ⇄
- Dolby NR switch; Off
- ATC switch; Off
- Headphones volume control: Maximum
- Make sure heads are clean
- Make sure capstan and pressure roller are clean
- Judgeable room temperature $20 \pm 5^{\circ}\text{C}$ ($68 \pm 9^{\circ}\text{F}$)

Measuring Instrument

- EVM (Electronic Voltmeter)
- Oscilloscope
- AF oscillator
- ATT (Attenuator)
- Resistor (600Ω)

NOTE: Before adjustment, be sure to set the AF oscillator output level to 0dB (1kHz): 1V

Test tape

- Playback gain adjustment (315Hz, 0dB); QZZCFM
- Overall gain adjustment and Overall frequency response
Normal reference blank tape; QZZCRA
CrO₂ reference blank tape; QZZCRX
Metal reference blank tape; QZZCRZ

NOTE: Step 2 to step 7 only has to be done after exchange of the EEPROM.

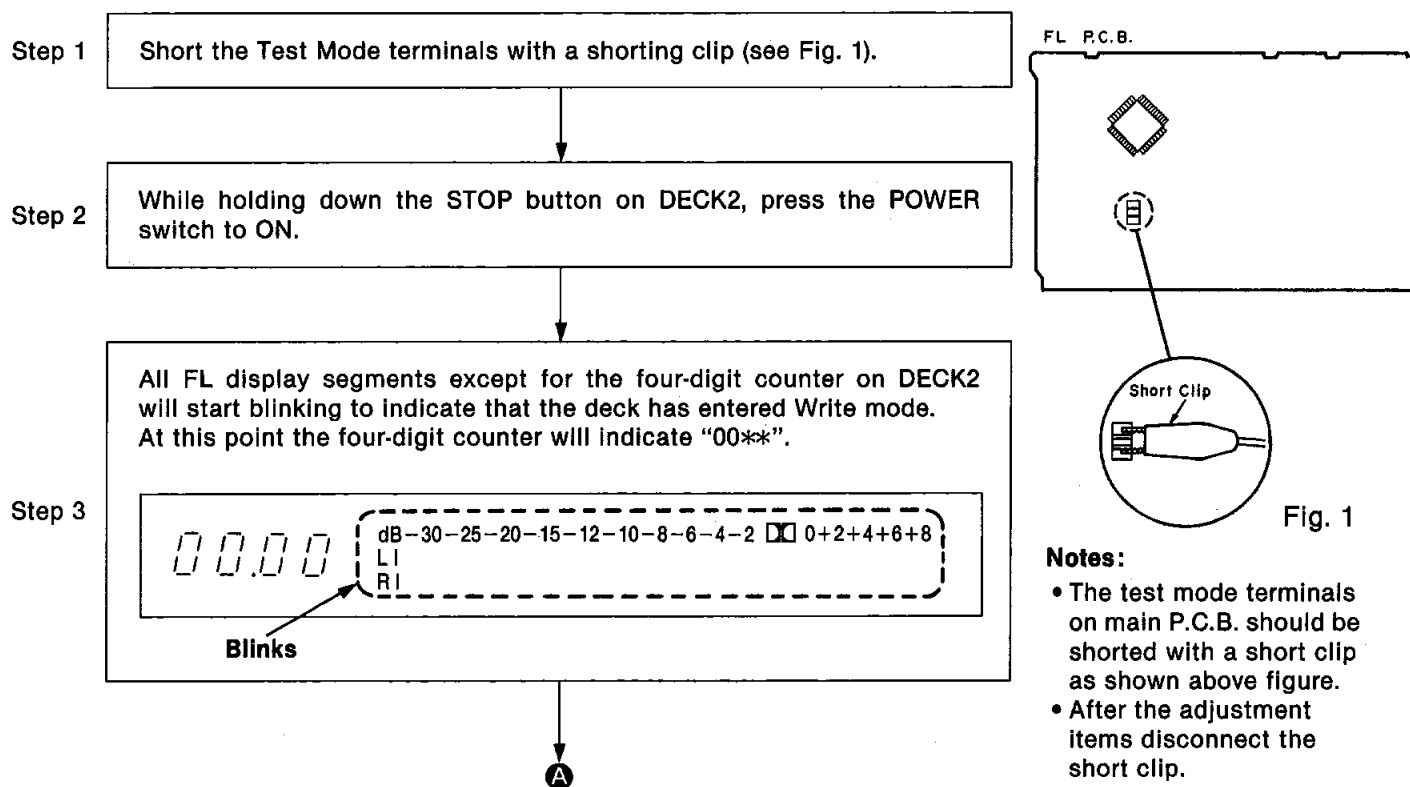

A

Step 4

The counter shows a four-digit hex number. The two high-order digits indicate a ROM address, and the two low-order digits indicate the data stored at that address.

Step 5

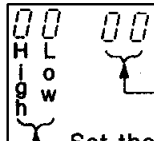

Set these digits using the FF or REW button. The high- and low-order digits of the address increment alternately each time the FF button is pressed. The REW button causes these digits to decrement alternately. For fast incrementing or decrementing, hold down the FF or REW button.

Set these digits using the REC or PAUSE button. The high- and low-order digits of the data increment alternately each time the REC button is pressed. The PAUSE button causes these digits to decrement alternately. For fast incrementing or decrementing, hold down the REC or PAUSE button.

Example: Set "FF" in address 03 (see Fig. 3).

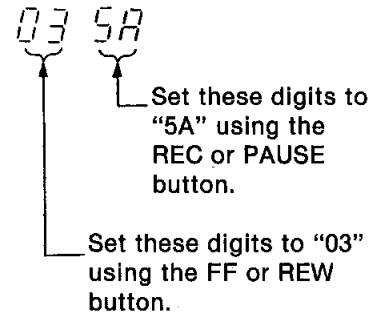

Set these digits to "5A" using the REC or PAUSE button.

Set these digits to "03" using the FF or REW button.

* The data writing process is complete when the next address number appears. For example, writing of the data 03.5A has been completed when the address 04 is displayed.

Step 6

Begin from address 00 and write data up to address 7F (data in). Check that the data at address 7F is "00" (end), and then exit the write mode.

Step 7

After completing ROM writing, press the STOP button on DECK2 to restore the normal Test mode. The four-digit counter on DECK1 displays.

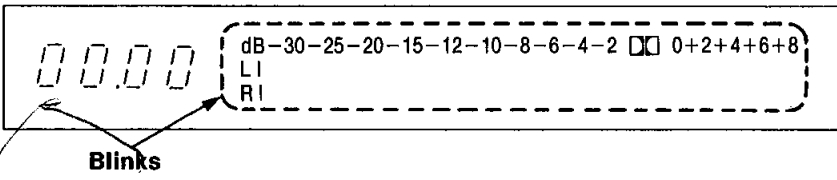

Blinks

PLAYBACK GAIN

Step 8

- Set the AF oscillator's output frequency to 315Hz/-20dB (100mV) (see Fig. 2).
- With no tape loaded in the deck, press and hold the REC button. Adjust the test signal level using the Rec. Level and Balance controls until the line output levels on both channels are 320mV. When the adjustment is complete, release the REC button. (The deck stores the data at the moment the REC button is released.)
- Load the test tape, QZZCFM, into the deck and locate the section of the tape where the playback gain test tone (315Hz, 0dB) is recorded, then playback the portion. Press the ATC button, and the display will flash -ATC MEMORY- slowly, meaning that playback gain is being automatically adjusted. Press the FOW. PLAY button. (At this point the deck automatically adjusts playback gains.) After this play back the tape and verify that the output level falls in the specified range.

Standard value: 320mV ± 0.5dB

Note: If adjustment of PLAYBACK GAIN fails, the display will flash -ATC MEMORY- rapidly. After a successful adjustment, the display will no longer show -ATC MEMORY-.

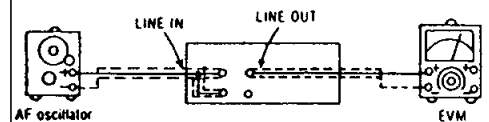

Fig. 2

B

Ⓑ

**INITIAL SETTING UP FOR OVERALL GAIN
AND OVERALL FREQUENCY RESPONSE**

Step 9

- Load a Normal blank test tape (QZZCRA) into the deck under test. Press the ATC button, then the REC button. The display will flash –ATC MEMORY– slowly. (At this point the deck automatically adjusts the overall gain and frequency response.)
 - After the above setting, the overall gain for selection of CrO₂ and Metal tape will be automatically set by the ROM and stored in the ROM.
- Note:** If adjustment of OVERALL GAIN or OVERALL FREQUENCY RESPONSE fails, the display will flash –ATC MEMORY– rapidly. After a successful adjustment, the display will no longer show –ATC MEMORY–.

Step 10

Remove the shorting clip from the Test Mode terminals. The FL display will stop blinking.

Note: If the microprocessor is replaced, it is not necessary to replace (or write data to) the EEPROM.

• **EEPROM MAP**

High Low	0	1	2	3	4	5	6	7
0	00	—	—	—	—	—	—	—
1	—	—	—	—	—	—	—	—
2	—	—	—	—	—	—	—	—
3	5A	—	—	—	—	—	—	—
4	—	—	—	—	—	68	84	90
5	—	—	—	—	—	78	60	60
6	—	—	—	—	—	38	30	18
7	—	—	—	—	—	64	68	78
8	—	—	—	—	—	A8	B0	8C
9	—	—	—	—	94	—	—	—
A	—	—	6A	0F	—	—	—	—
B	—	—	70	2B	—	—	—	—
C	—	—	4B	12	—	—	—	—
D	—	—	72	07	—	—	—	—
E	—	—	4C	FB	00	70	74	04
F	—	—	53	F5	00	—	—	00

Fig. 3

Note: At an address with no data value indicated (e.g. 01 → —), the ROM operates normally irrespective of the kind of the data supplied.

MEASUREMENTS AND ADJUSTMENTS

Measurement Condition

- Recording-level control; Maximum
- Recording-balance control; Center
- Reverse-mode selector switch; ⇌
- Headphones volume control; Maximum
- Dolby NR switch; Off
- ATC switch; Off

- Make sure heads are clean
- Make sure capstan and pressure roller are clean
- Judgeable room temperature $20 \pm 5^{\circ}\text{C}$ ($68 \pm 9^{\circ}\text{F}$)

Measuring instrument

- EVM (Electronic Voltmeter)
- Oscilloscope
- Digital frequency counter
- AF oscillator

- ATT (Attenuator)
- DC voltmeter
- Resistor (600Ω)

NOTE: Before adjustment, be sure to set the AF oscillator output level to 0dB (1 kHz): 1V

Test tape

- Head azimuth adjustment (8kHz, -20dB)
- Playback frequency response (315Hz, 12.5kHz, 10kHz, 8kHz, 4kHz, 1kHz, 250Hz, 125Hz, 63Hz, -20dB)
- Playback gain adjustment (315Hz, 0dB)

; QZZCFM

- Tape speed adjustment (3kHz, -10dB); QZZCWAT
- Overall gain adjustment and Overall frequency response
Normal reference blank tape; QZZCRA
CrO₂ reference blank tape; QZZCRX
Metal reference blank tape; QZZCRZ

Adjustment Points

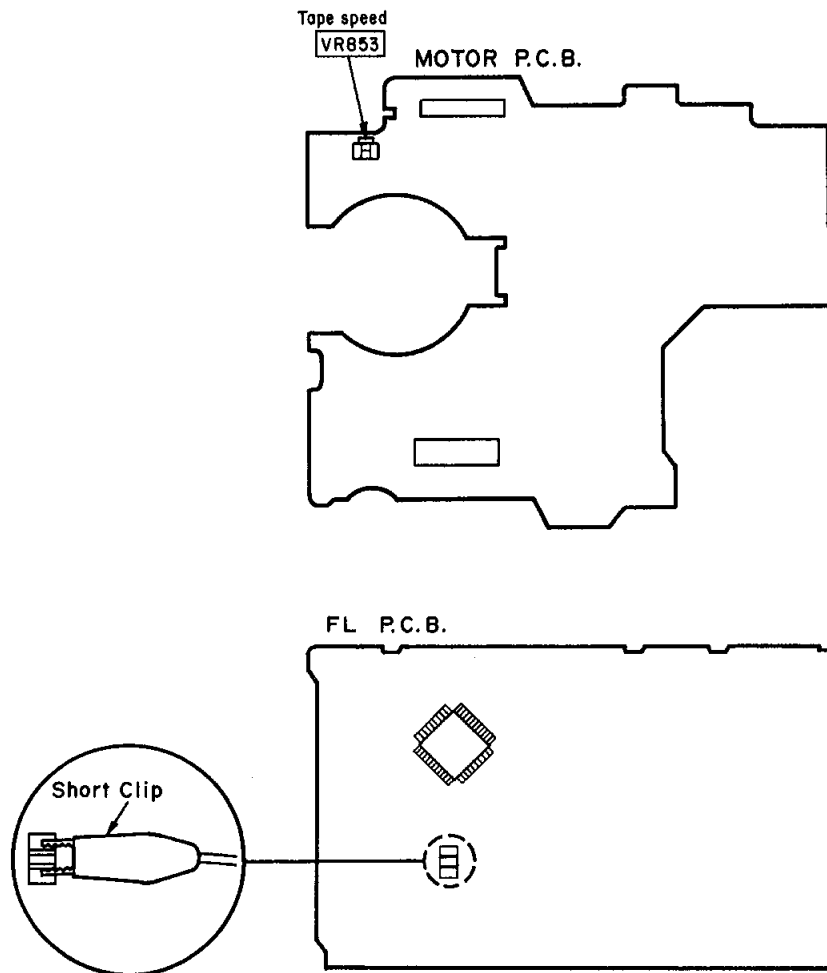

Notes:

- The test mode terminals on main P.C.B. should be shorted with a short clip as shown left figure.
- After the adjustment items disconnect the short clip.

HEAD REPLACEMENT

When replacing the head, adjust the head azimuth as instructed below, and rewrite the data to the EEPROM. (By adjusting head azimuth, data is automatically written to the EEPROM.)

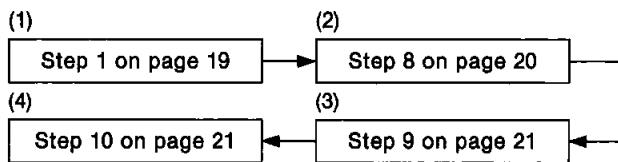

(The adjustment is necessary because the playback gain, the overall gain, and the overall frequency response are changed by the head replacement.)

HEAD AZIMUTH ADJUSTMENT

1. Playback the azimuth adjustment portion (8kHz, -20dB) of the test tape (QZZCFM). Vary the azimuth adjusting screw until the output of the R-CH are maximized.
2. Perform the same adjustment in the play mode.
3. Repeat the same check in reverse play mode.
4. After the adjustment, apply screwlock to the azimuth adjusting screw.

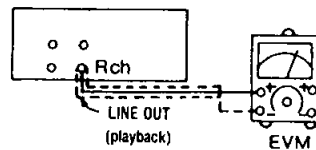

Fig. 4

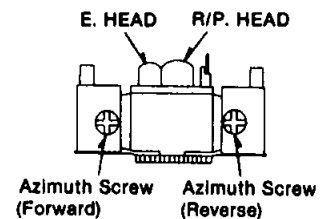

Fig. 5

TAPE SPEED ADJUSTMENT

1. Playback the middle portion of the test tape (QZZCWAT).
2. Short the test terminal.
3. Adjust VR853 so that the output is within the adjustment target.

Adjustment target: 3000 ± 15 Hz

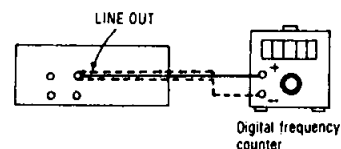

Fig. 6

PLAYBACK GAIN MEASUREMENT

1. Short the test terminal.
2. Load the test tape (QZZCFM) into the deck and locate the part where the playback gain test tone (315Hz, 0dB) is recorded. After this, play back the tape and verify that the output level falls in the specified range.

Standard value: $320\text{mV} \pm 0.5\text{dB}$

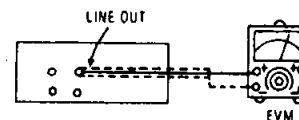
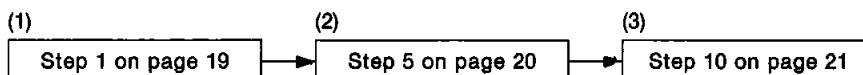

Fig. 7

3. Release the test terminal.
4. When the data is not within the specified range, the head azimuth should be readjusted as instructed below and the data in the EEPROM rewritten. (By adjusting head azimuth, data is automatically written to the EEPROM.) When adjusting head azimuth, check the test tape for scratches or crease. If any exist, use a different tape and follow instructions 1 to 3 below.



PLAYBACK FREQUENCY RESPONSE

1. Playback the frequency response portion (315Hz, 12.5kHz~63Hz, -20dB) of the test tape (QZZCFM).
2. Assure that the frequency response is within the range shown in Fig. 9 for both L-CH and R-CH.

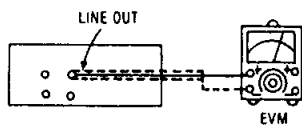

Fig. 8

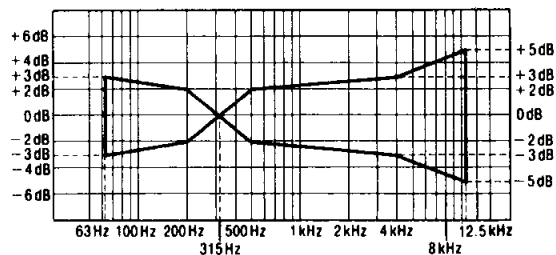

Fig. 9

ERASE CURRENT MEASUREMENT

1. With no tape loaded in the deck, press the Record button.
2. Check if the output at this time between the erase current confirmation point TP1 and GND (chassis) is within the standard value.

Standard value: 190 ± 25mA (Metal)..EVM Reading: 190 ± 25mV

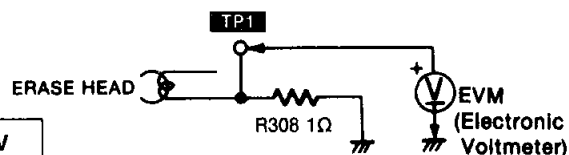

Fig. 10

CONFIRMATION OF THE OVERALL GAIN AND OVERALL FREQUENCY RESPONSE

1. In the Record Pause mode, load a normal blank tape (QZZCRA) into the deck, and apply the reference input signal (1kHz, -24dB) to the Rec. input. Adjust the output to 320mV with the attenuator, and start recording.
2. While playing back the reference signal just recorded, verify that the output level falls in the following range.

Standard value: 320mV ± 0.5dB

3. Afterward, apply a signal (frequency at the measured point in the range from 50Hz to 10kHz), whose level is 20dB lower than the reference signal level (1kHz, -24dB=approx. 63mV), to the Rec. input. Then start recording with a normal blank tape (QZZCRA).
4. Play back the test signals just recorded and verify that the levels at the test frequencies fall in the ranges specified in Fig. 11 with respect to the reference signal level.
5. Repeat steps 3 and 4 above for CrO₂ blank test tape (QZZCRX) and Metal blank test tape (QZZCRZ), in these cases raising the upper end of the test signal frequency range to 12.5kHz. Verify that the signal levels at the test frequencies fall in the ranges specified in Fig. 12 with respect to the reference signal level.
6. Steps 1 through 2 above are concerned with overall gain; steps 3 through 5 pertain to overall frequency response.
7. When the data is not within the specified range, the head azimuth should be readjusted as instructed below and the data in the EEPROM rewritten. (By adjusting head azimuth, data is automatically written to the EEPROM.) When adjusting head azimuth, check the test tape for scratches or creases. If any exist, use a different tape and follow instructions 1 to 4 below.
8. If outside the standard value, data in EEPROM should be written again by taking the following procedure and there thereafter section 1-6 should be carried out again.

Normal Overall frequency response chart (NR OUT)

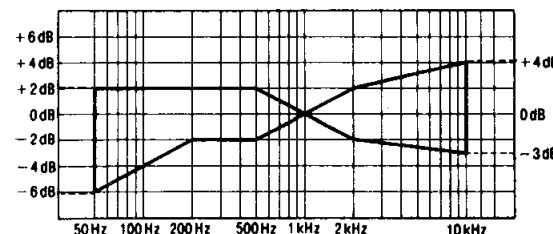

Fig. 11

CrO₂ Metal Overall frequency response chart (NR OUT)

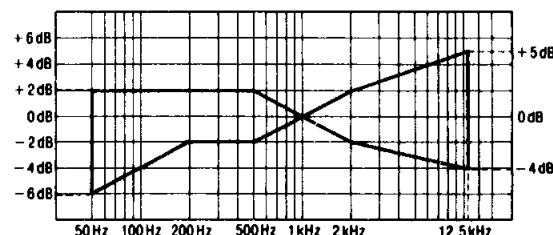

Fig. 12

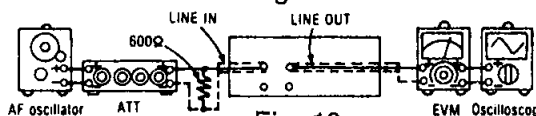
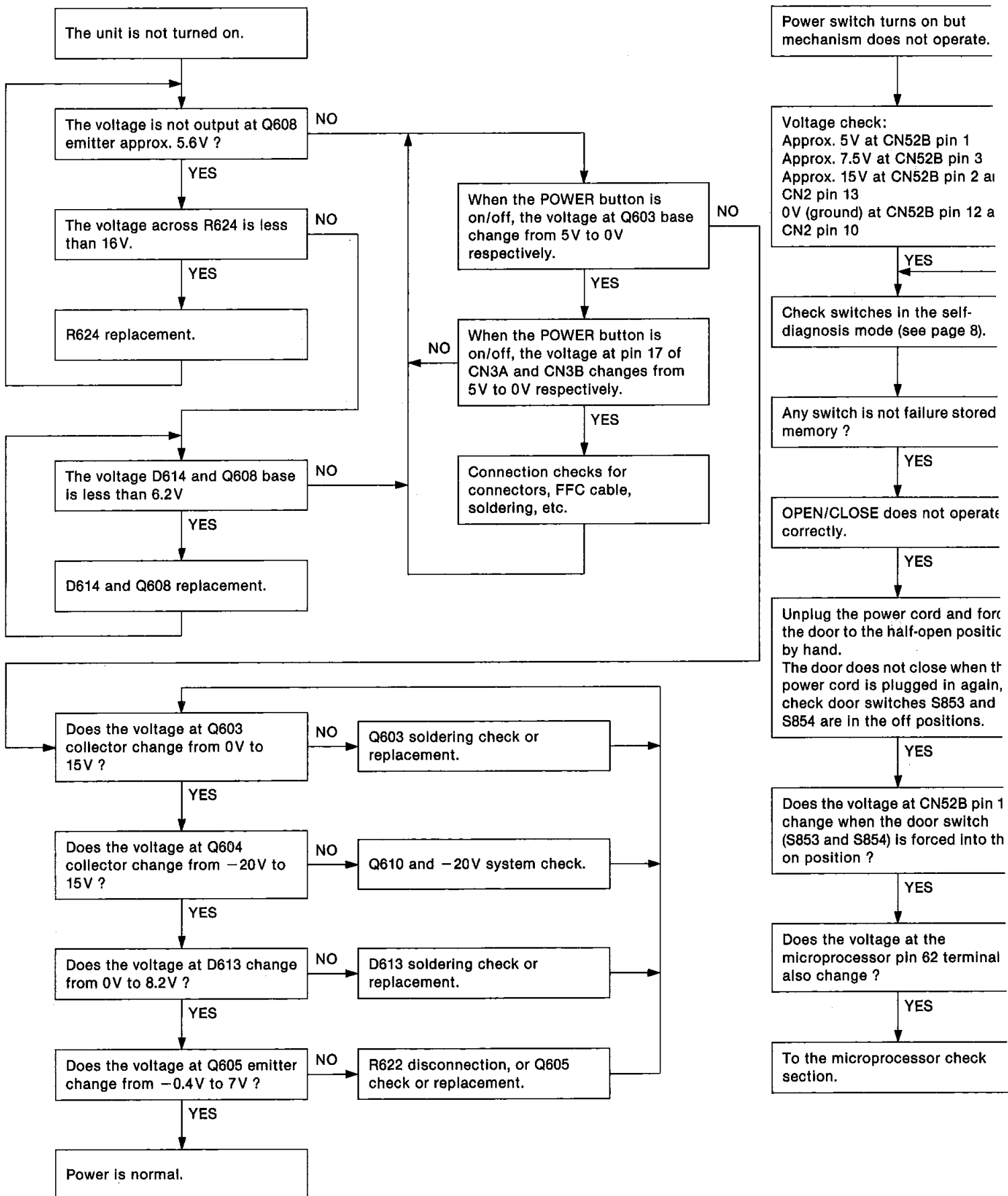

Fig. 13



TROUBLESHOOTING GUIDE

*To perform troubleshooting, set the unit to the state described in the "Motor Control PCB Checking Method" on page 31.



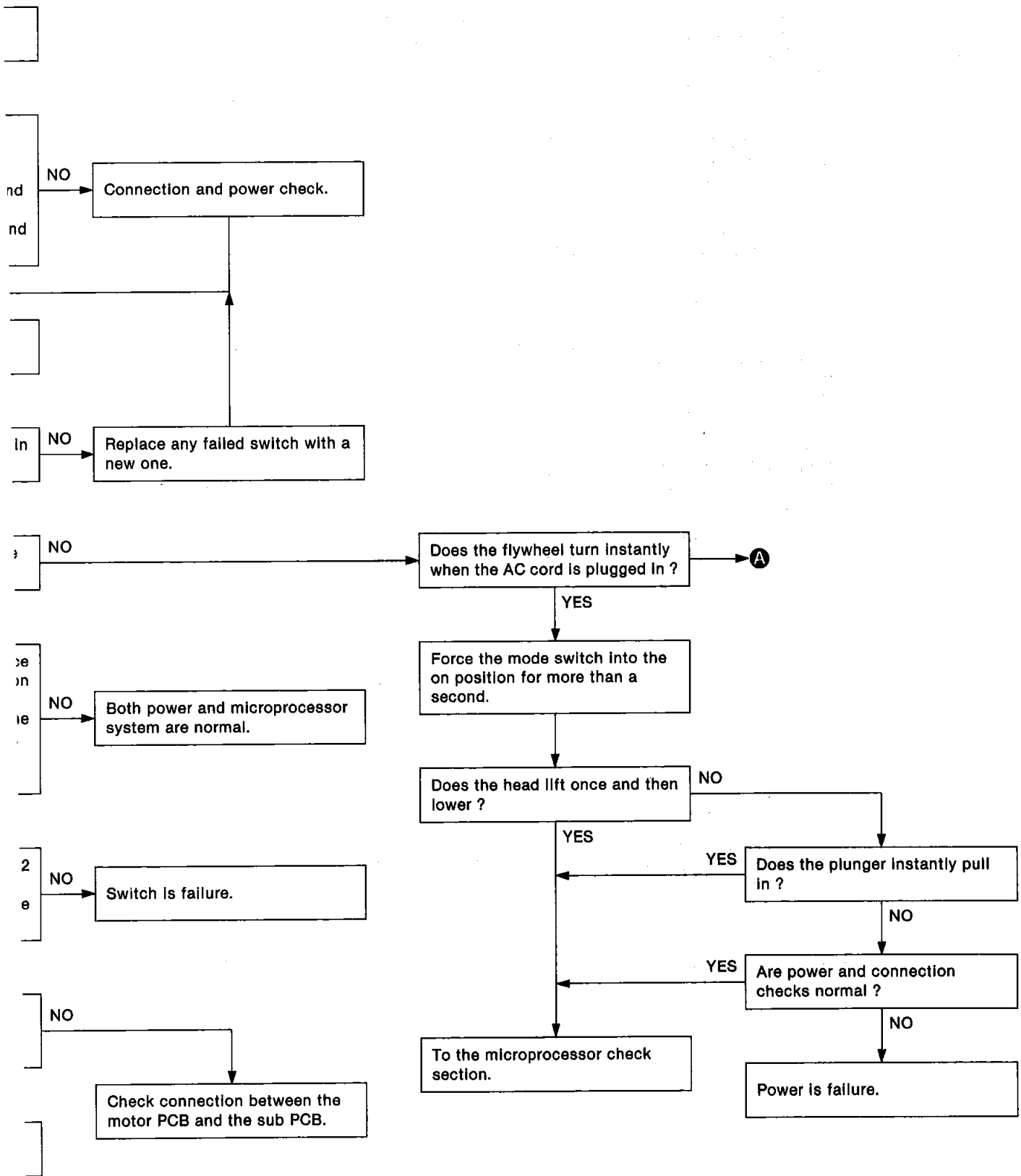

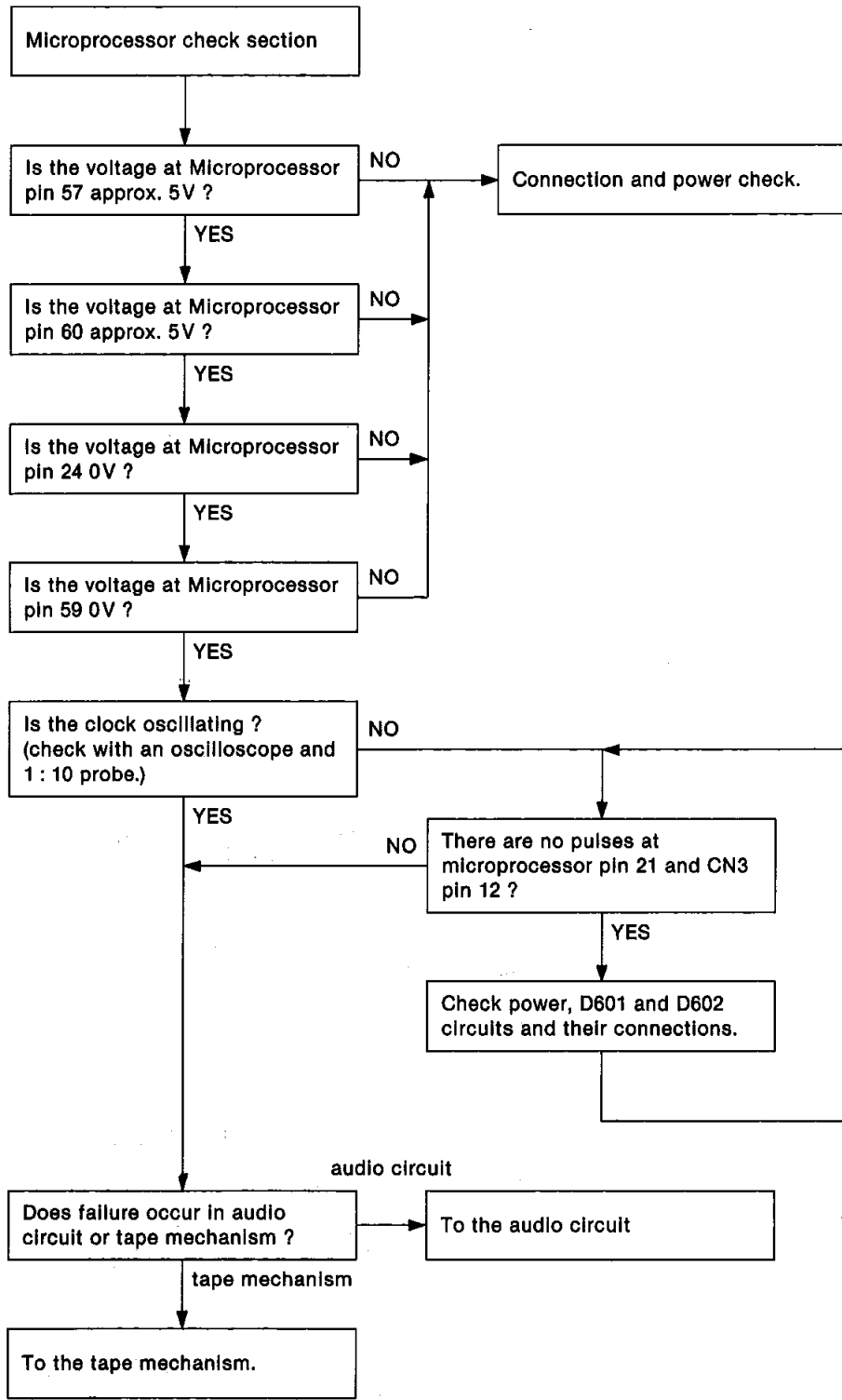

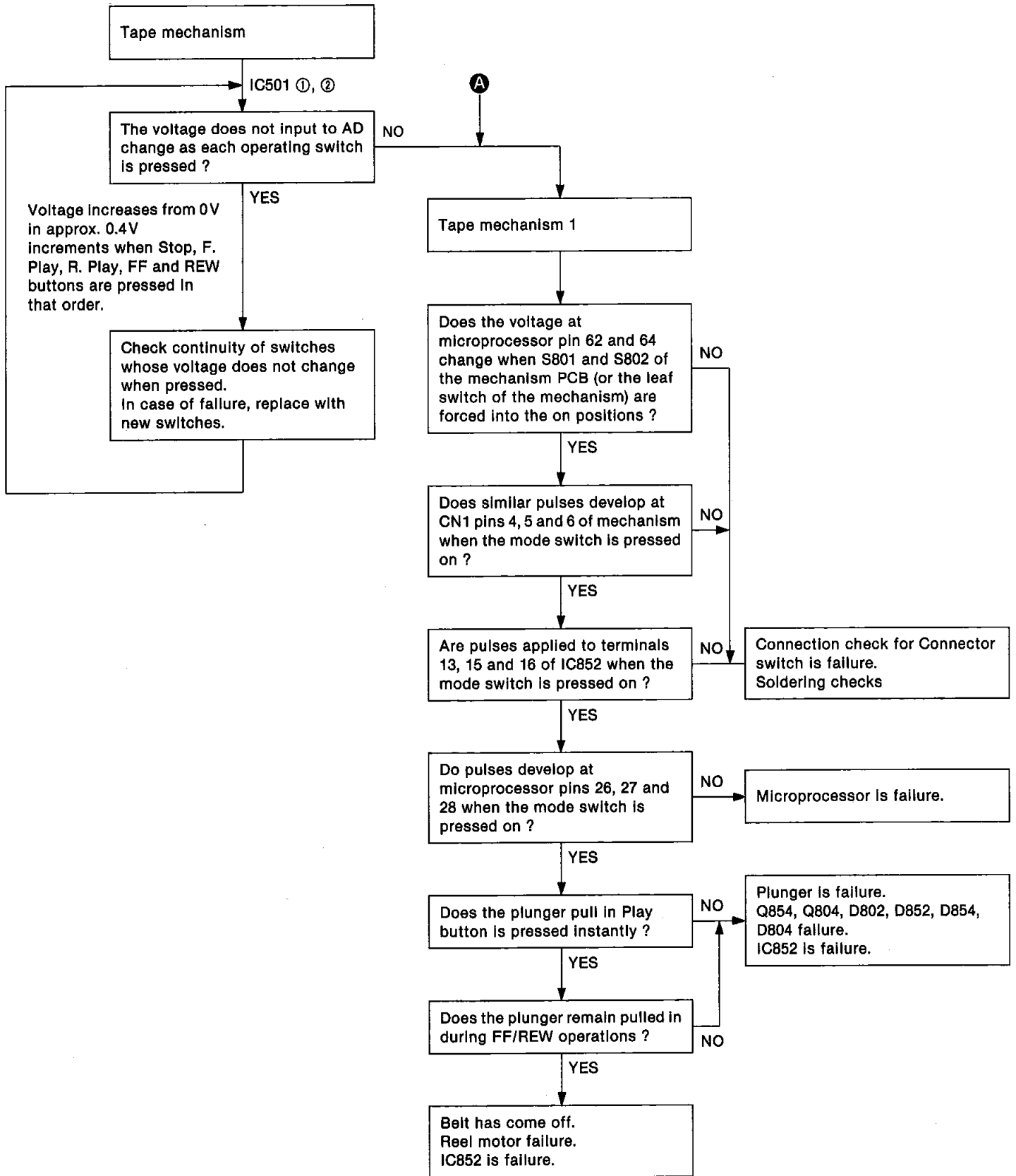

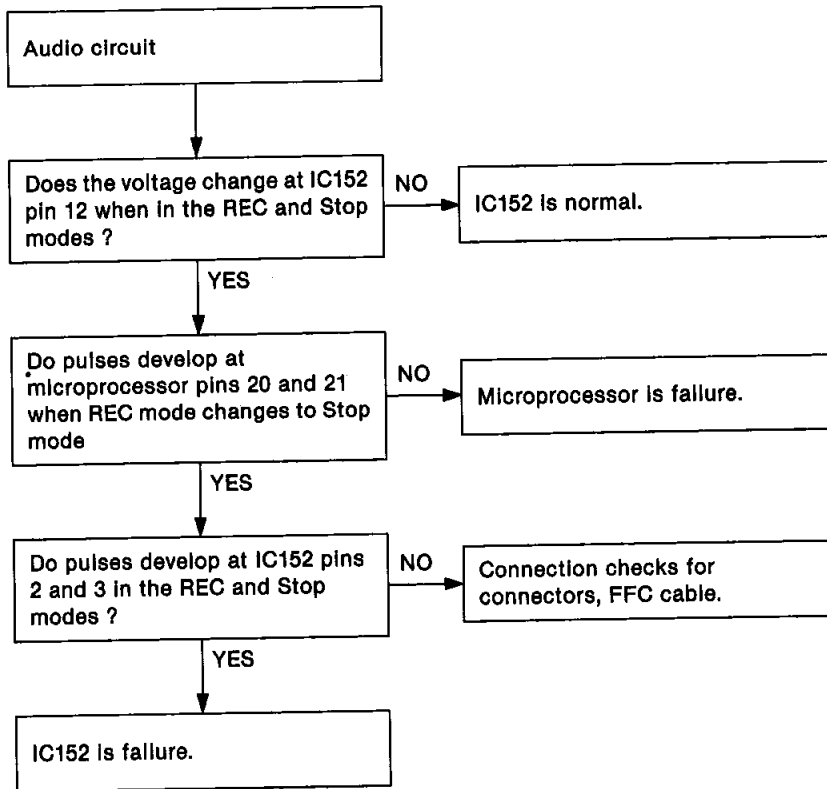

As shown above, check the voltage at each pin of IC152 for the following:

- ① Equalizer 120 μ s/70 μ s change.
- ② Dubbing seed does not change.
- ③ Erase current does not change between the CrO₂ and Normal/Metal tape.
(Erase current for CrO₂ and Normal tape is the same.)
- ④ Deck 1 and deck 2 produces no change.
- ⑤ Dolby off, B and C produces no change.
- ⑥ REC and Play produces no change.
- ⑦ Auto REC mute does not operate.

BLOCK DIAGRAM

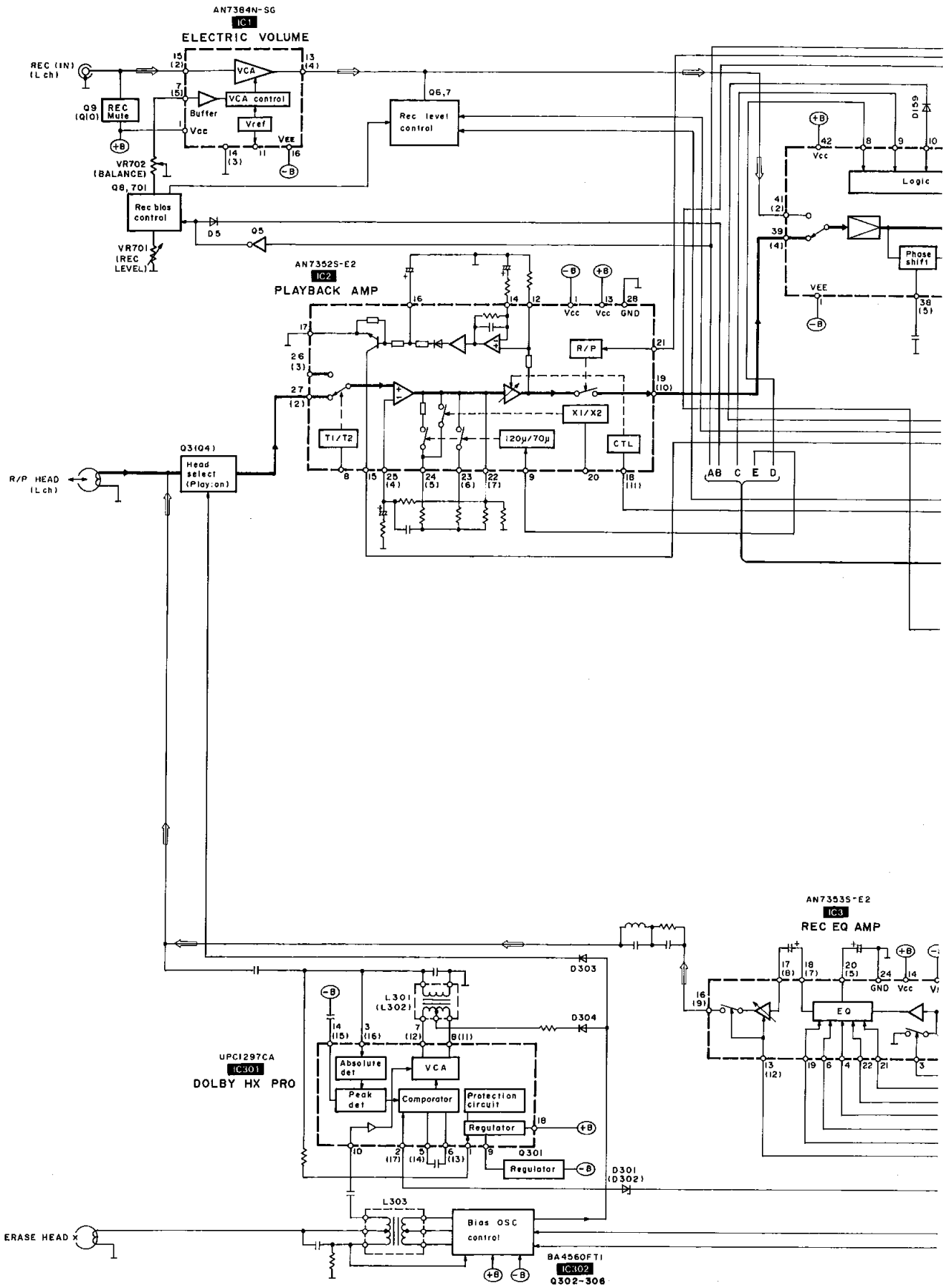

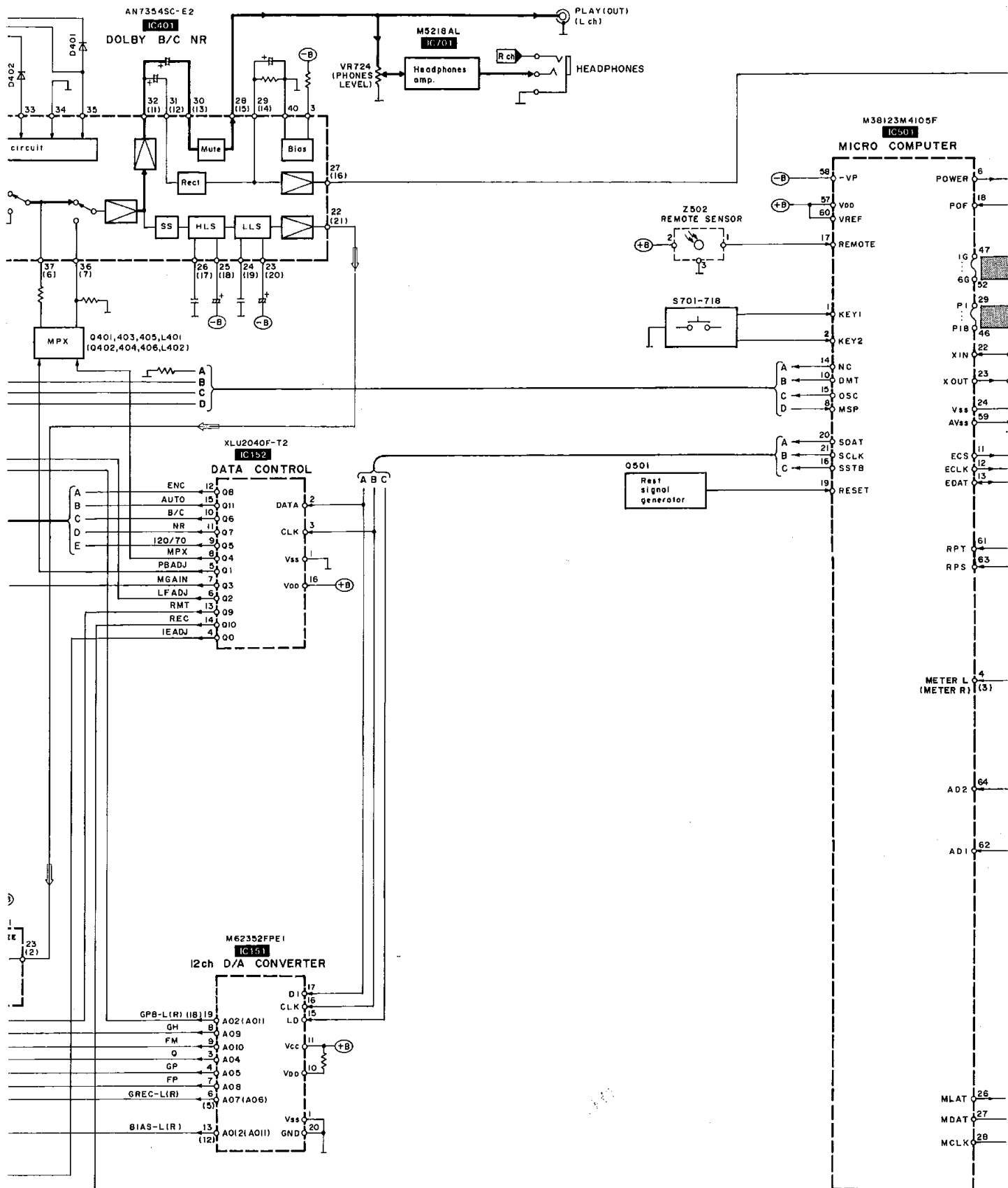

Notes.
 1) () indicates pin No. of right channel.
 2)

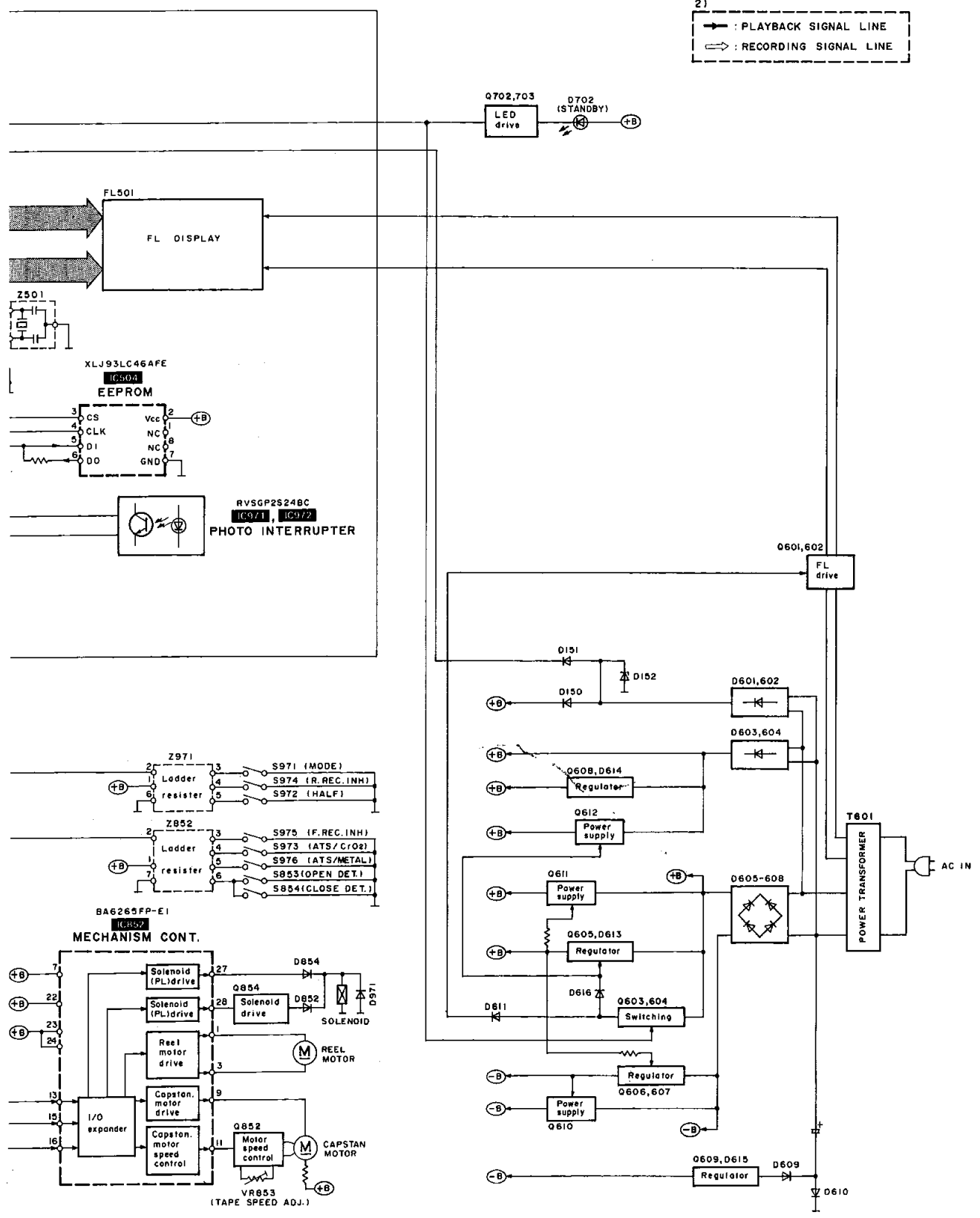

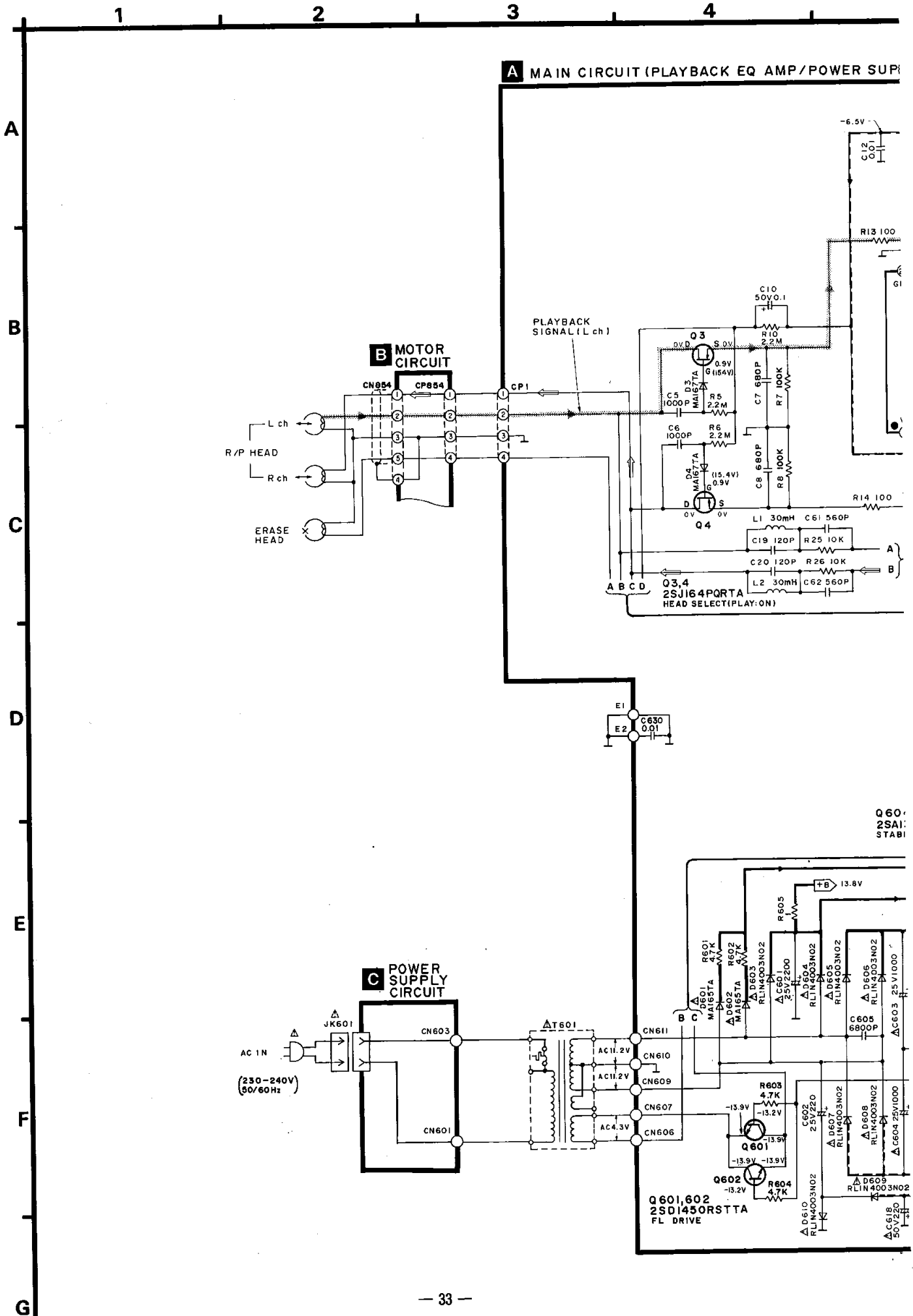

PLY/DOLBY NR/HX PRO/BIAS OSC/REC EQ AMP/CONTROL/ELECTRIC VOLUME)

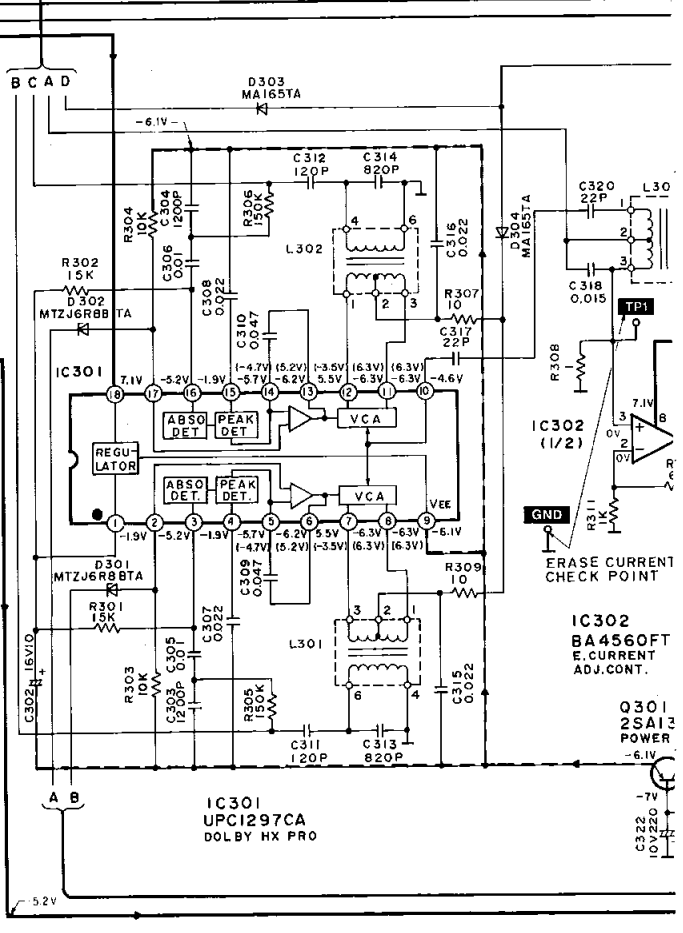
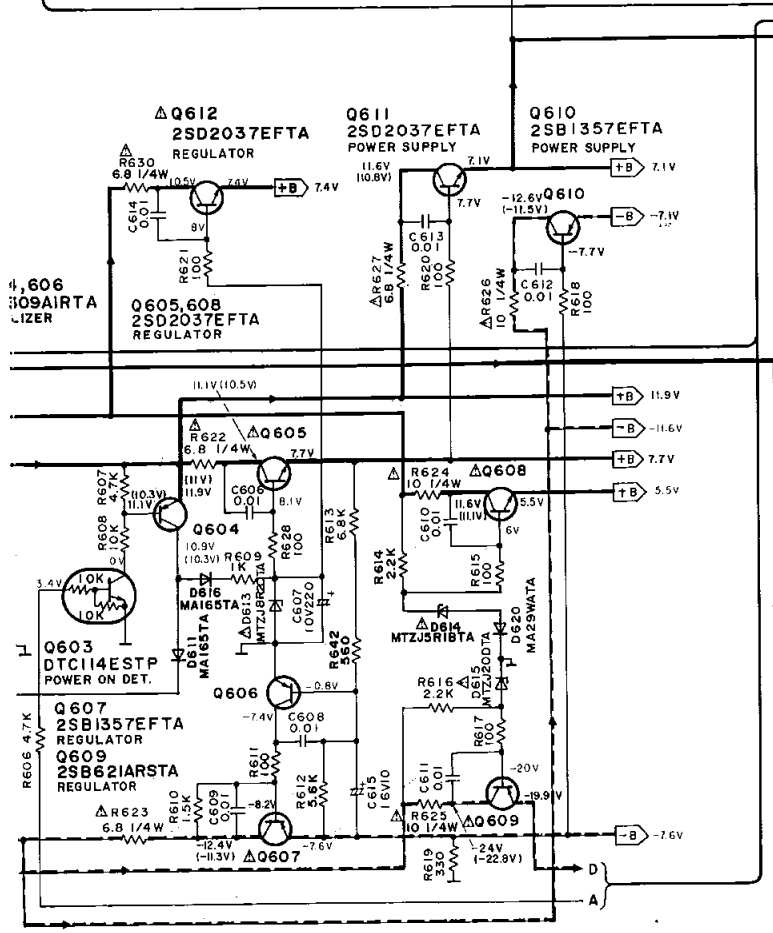
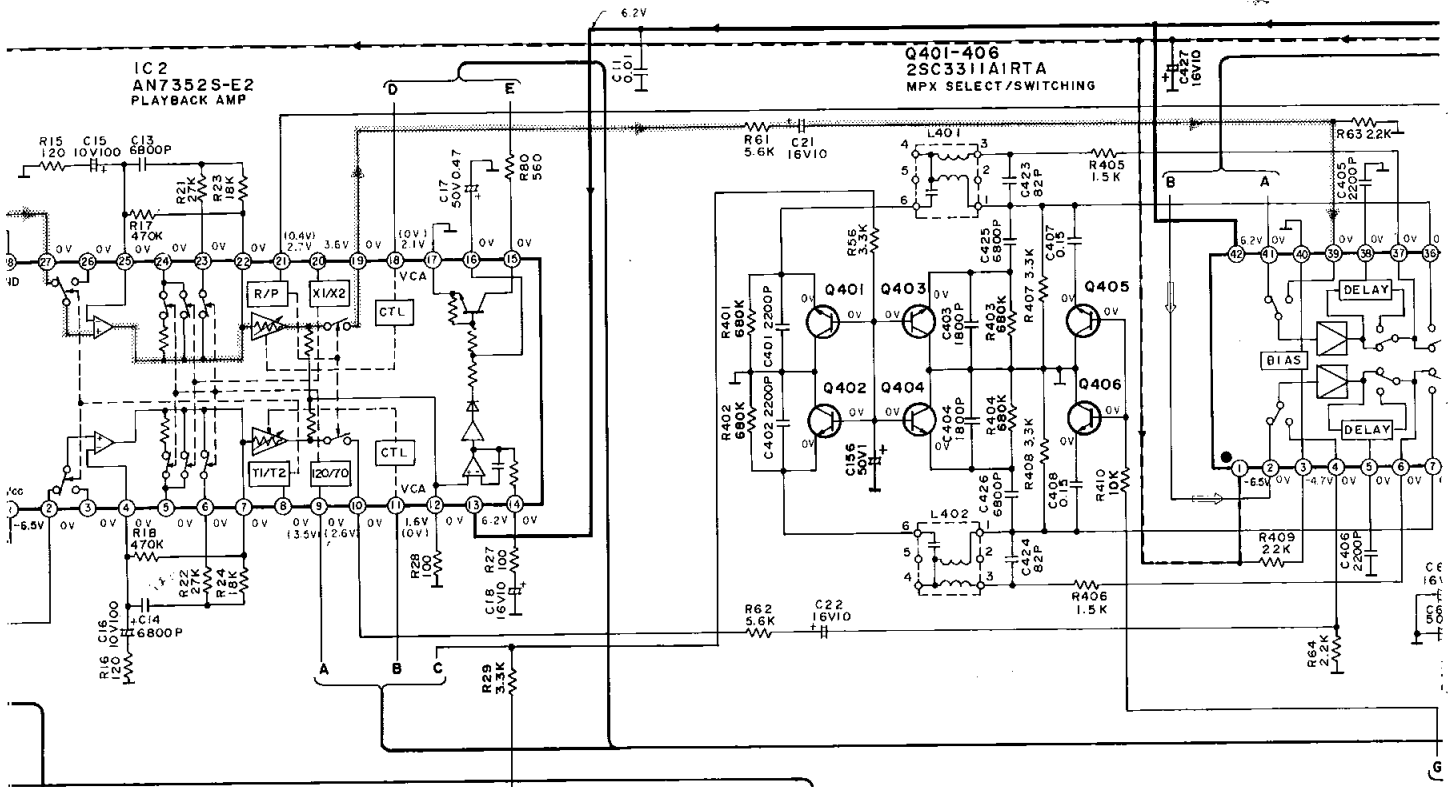

IC401
AN7354SC-E2
DOLBY B/C NR

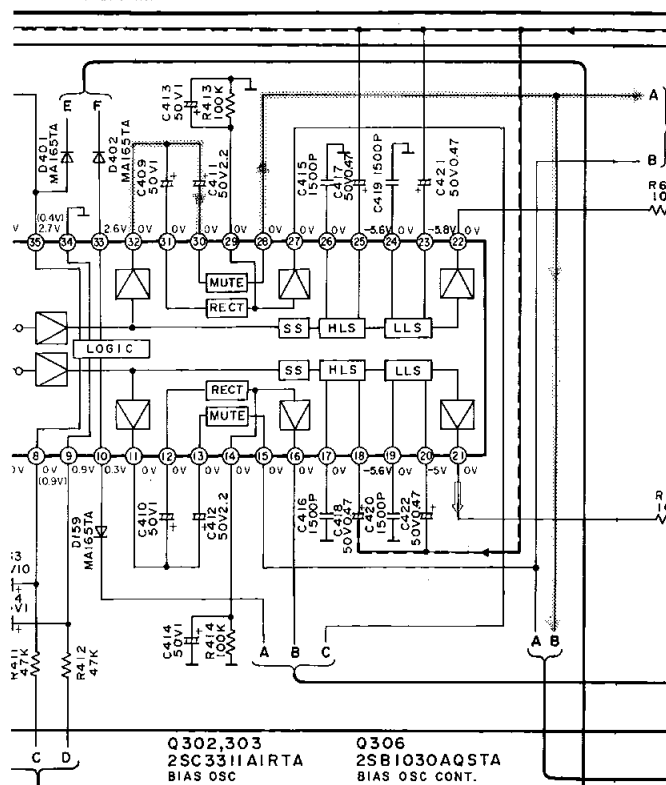

Q302,303
2SC3311AIRTA
BIAS OSC

Q306
2SB1030AQRSTA
BIAS OSC CONT.

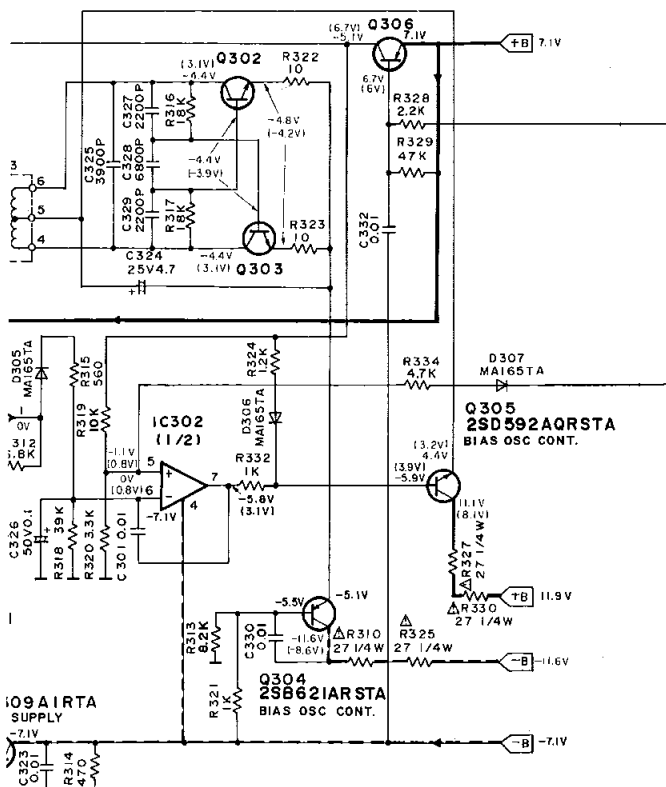

Q304 AIRTA
SUPPLY
2SB621AR STA
BIAS OSC CONT.

Q305
2SD592AQRSTA
BIAS OSC CONT.

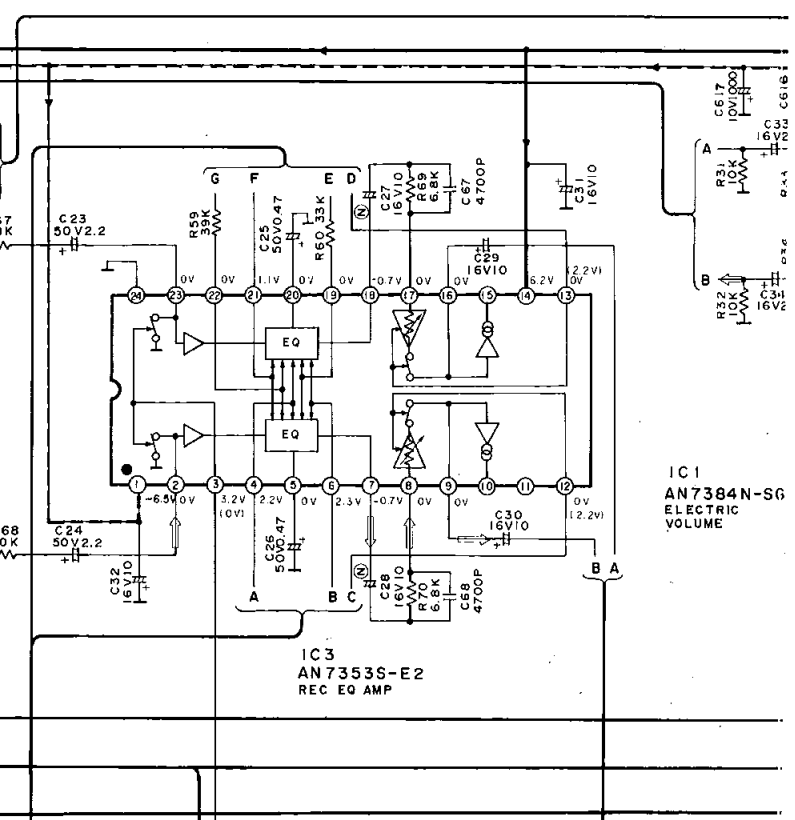

IC1
AN7384N-SG
ELECTRIC
VOLUME

IC3
AN7353S-E2
REC EQ AMP

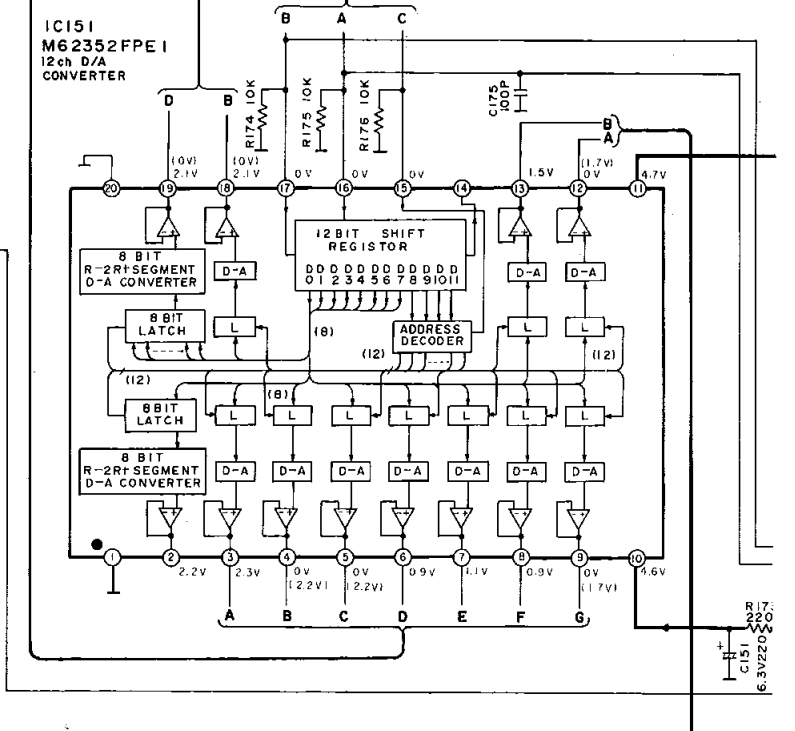

IC151
M62352FPE1
12ch D/A
CONVERTER

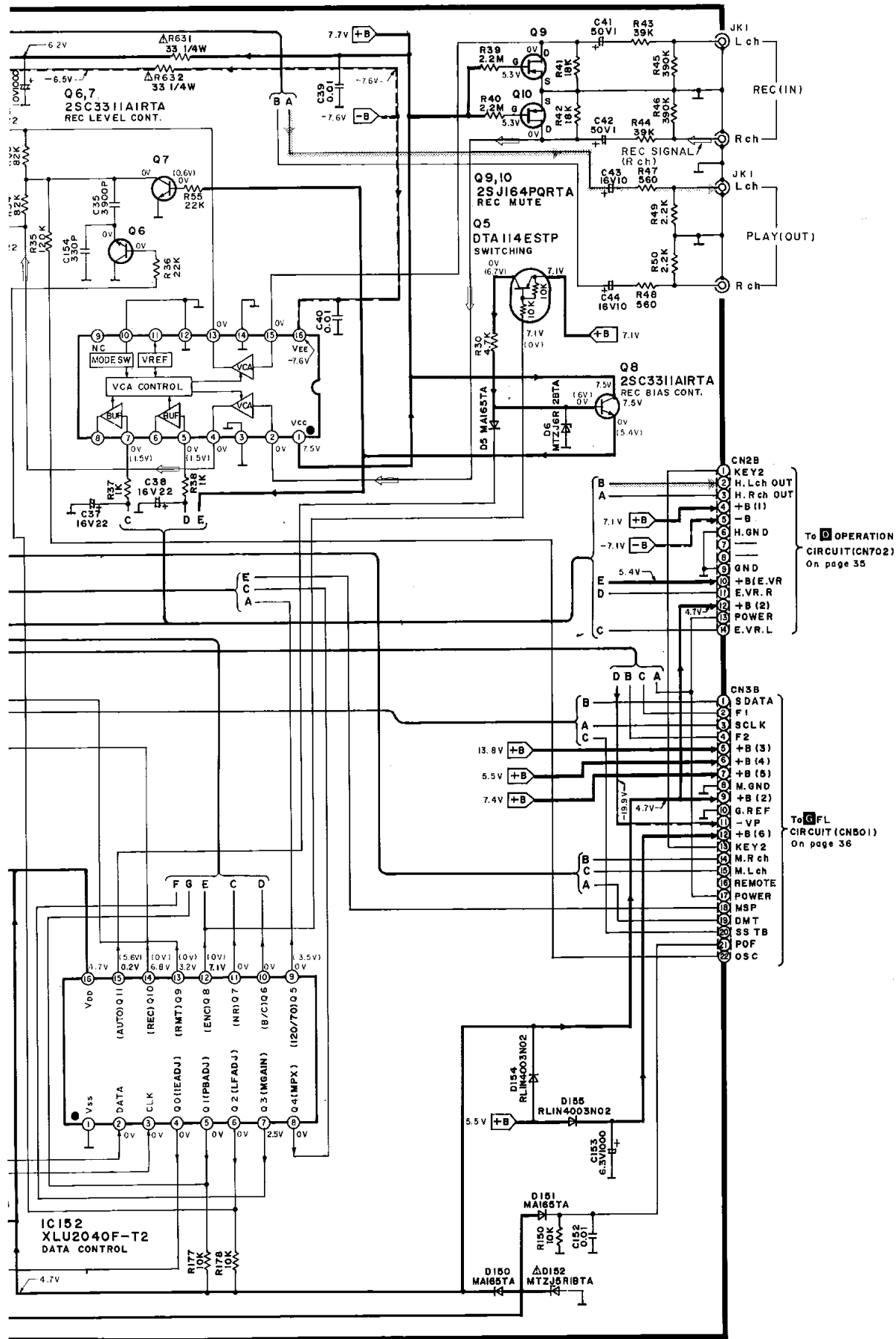

To **D** OPERATION CIRCUIT (CN702) On page 35

To **G** FL CIRCUIT (CN501) On page 36

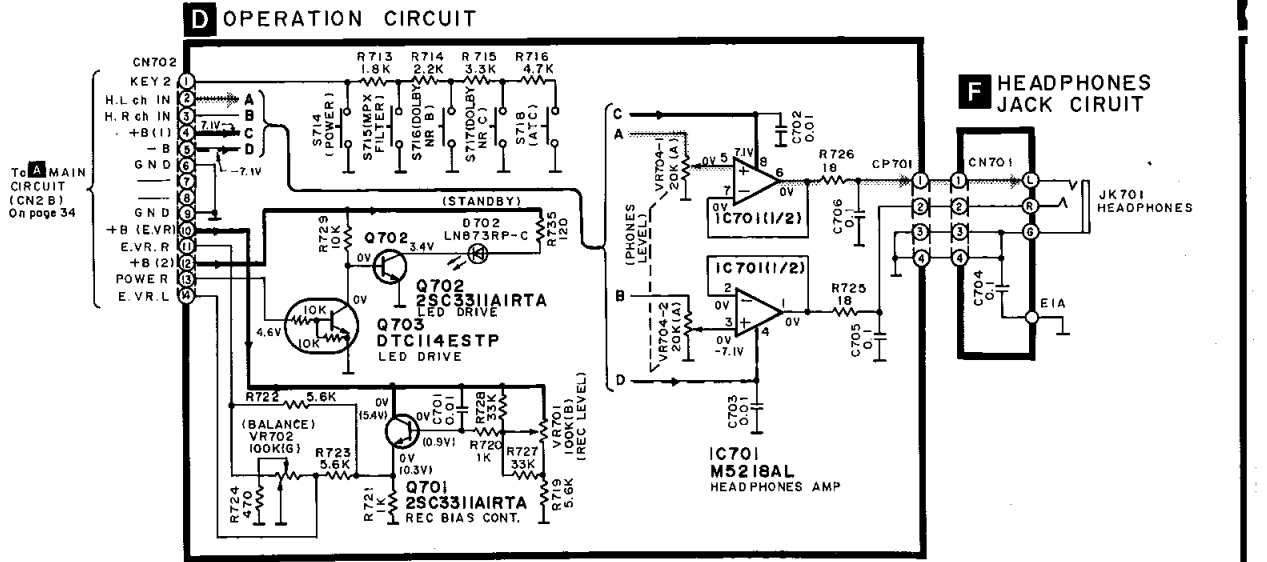

B MOTOR CIRCUIT

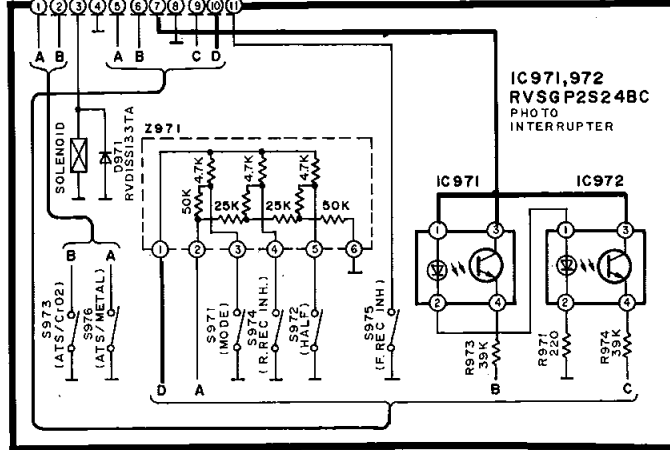
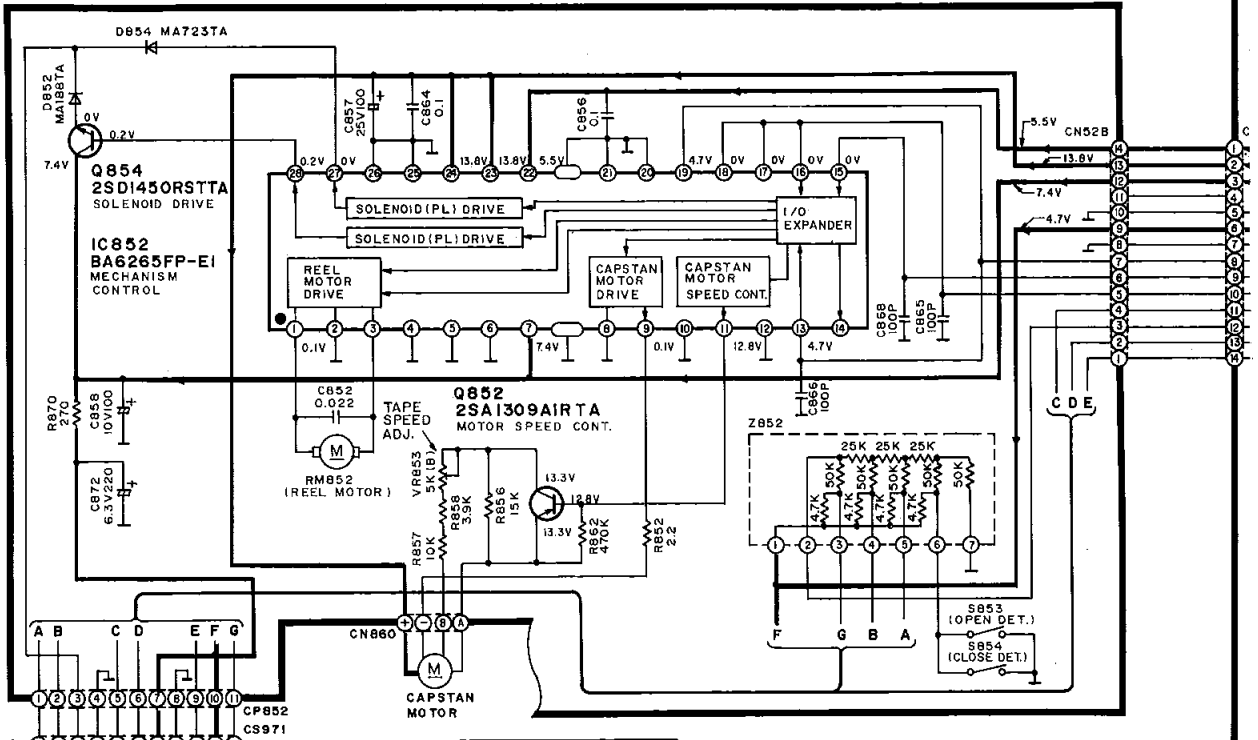

FL CIRCUIT

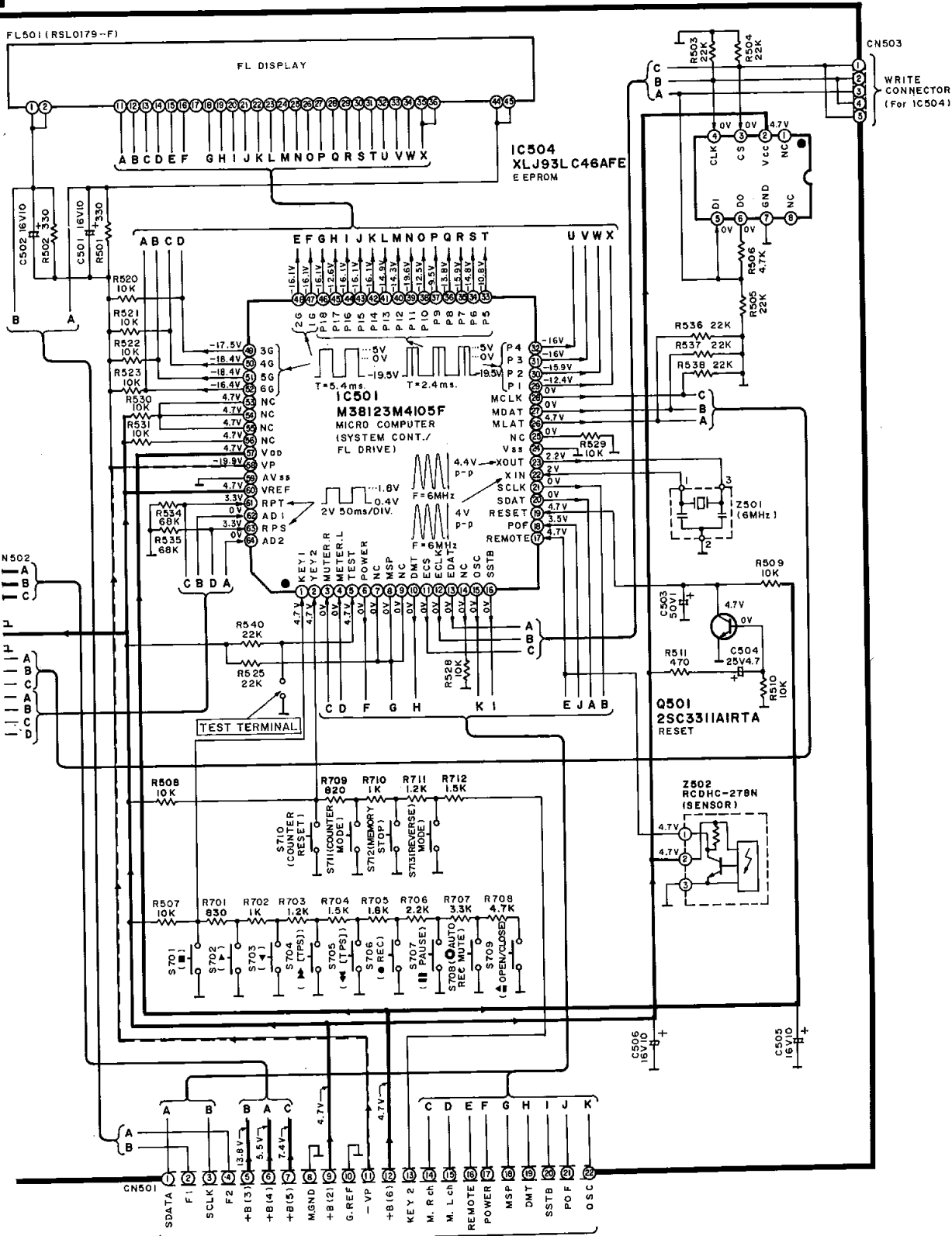





To MAIN CIRCUIT (CN3B)
On page 34

■ SCHEMATIC DIAGRAM (Parts list on pages 54~57.)

(This schematic diagram may be modified at any time with the development of new technology.)

Note 1:

- S701 : Stop switch (■).
- S702 : F.-SIDE playback (▶).
- S703 : R.-SIDE playback (◀).
- S704 : Fast-forward search [TPS] switch (▶▶ [TPS]).
- S705 : Rewind search [TPS] switch (◀◀ [TPS]).
- S706 : Record switch (● REC).
- S707 : Pause switch (■ PAUSE).
- S708 : Automatic-record-muting switch (● AUTO REC MUTE).
- S709 : Cassette holder open/close switch (▲ OPEN/CLOSE).
- S710 : Tape/liner counter reset switch (COUNTER RESET).
- S711 : Tape/liner counter mode switch (COUNTER MODE).
- S712 : Memory stop switch (MEMORY STOP).
- S713 : Reverse-mode select switch (REVERSE MODE).
- S714 : Power "STANDBY ϕ /ON" switch (POWER, STANDBY ϕ /ON).
- S715 : Multiplex filter switch (MPX FILTER).
- S716, : Dolby noise reduction switches (DOLBY NR B, C).
717 [S716: DOLBY NR B, S717: DOLBY NR C]
- S718 : Auto tape calibration switch (ATC).
- S853 : Cassette holder open detection switch in "off" position.
- S854 : Cassette holder close detection switch in "off" position.
- S971 : Mode switch in "off" position.
- S972 : Half switch in "off" position.
- S973 : ATS (CrO₂) switch in "off" position.
- S974 : R. REC inhibit switch in "off" position.
- S975 : F. REC inhibit switch in "off" position.
- S976 : ATS (Metal) switch in "off" position.
- Resistance are in ohms (Ω), 1/4 watt unless specified otherwise.
1K=1,000 (Ω), 1M=1,000k (Ω)
- Capacity are in micro-farads (μ F) unless specified otherwise.
- All voltage values shown in circuitry are under no signal condition and playback mode with volume control at minimum position otherwise specified.
()..... Voltage values at record mode.
- For measurement us EVM.
- Important safety notice
Components identified by Δ mark have special characteristics important for safety.
When replacing any of these components, use only manufacturer's specified parts.
- () Indicates +B (bias).
- () Indicates -B (bias).
- () Indicates the flow of the playback signal.
- () Indicates the flow of the record signal.
- The supply part number is described alone in the replacement parts list,

Ref. No.	Production Part No.	Supply Part No.
IC152	XLU2040F-T2	XLU2040F-T1
IC302	BA4560FT1	SVIBA4560FT1
IC701	M5218AL	M5218L

※ marks indicate printed resistor.

Caution!

IC and LSI are sensitive to static electricity.

Secondary trouble can be prevented by taking care during repair.

- Cover the parts boxes made of plastics with aluminum foil.
- Ground the soldering iron.
- Put a conductive mat on the work table.
- Do not touch the legs of IC or LSI with the fingers directly.

PRINTED CIRCUIT BOARDS

(This printed circuit boards may be modified at any time with the development of new technology)

A

G FL P.C.B. (REP1848A-S)

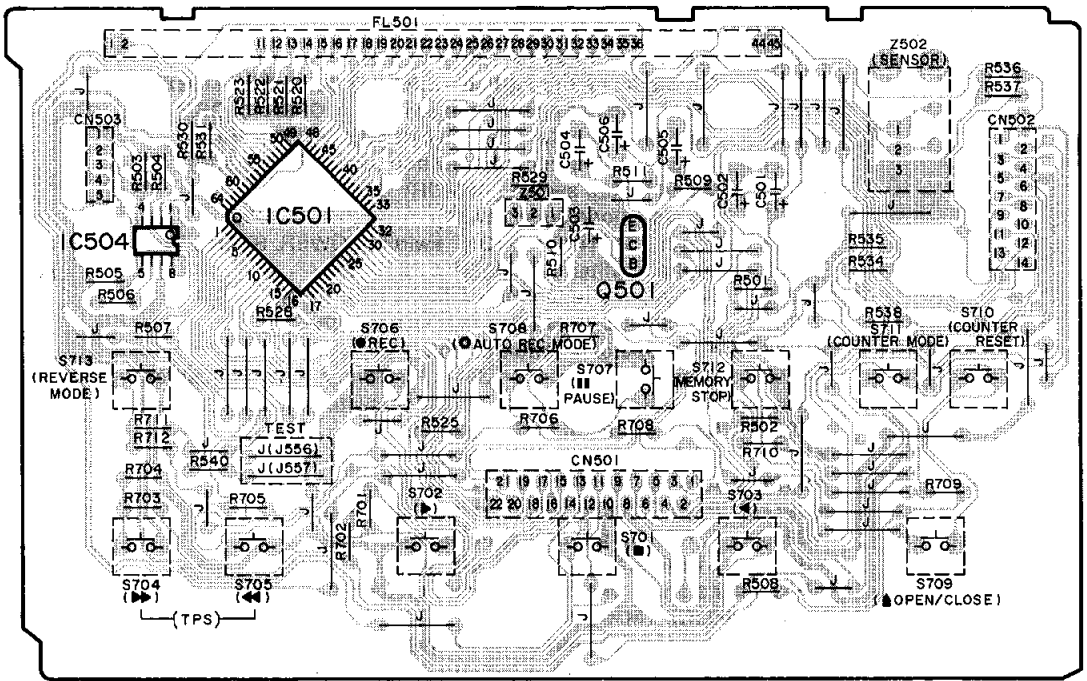

B

C

D

E

C POWER SUPPLY P.C.B. (REP1806C-P)

AC IN
(230-240V
50/60Hz)

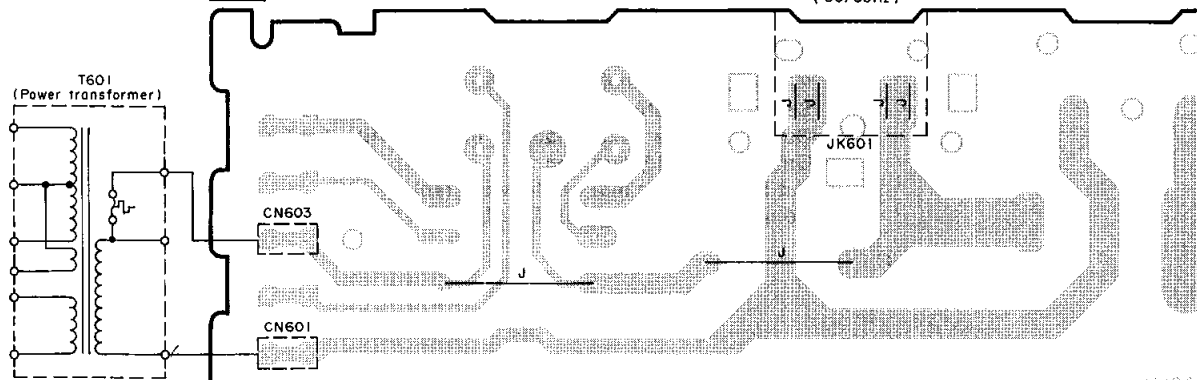

F

A MAIN P.C.B. (REP1849A-M)

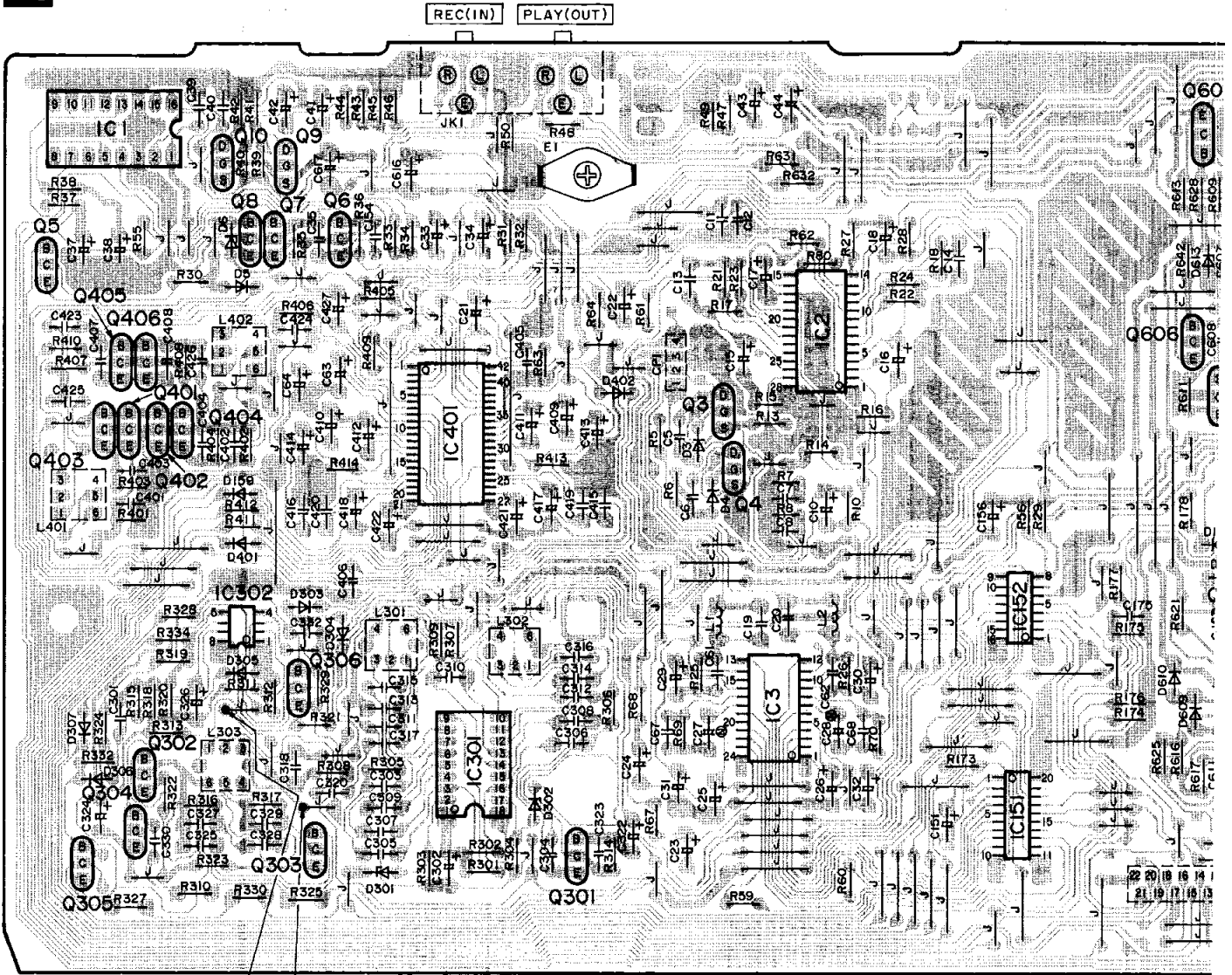

TPI GND
ERASE CURRENT
CHECK POINT

D OPERATION P.C.B. (REP1848A-S)

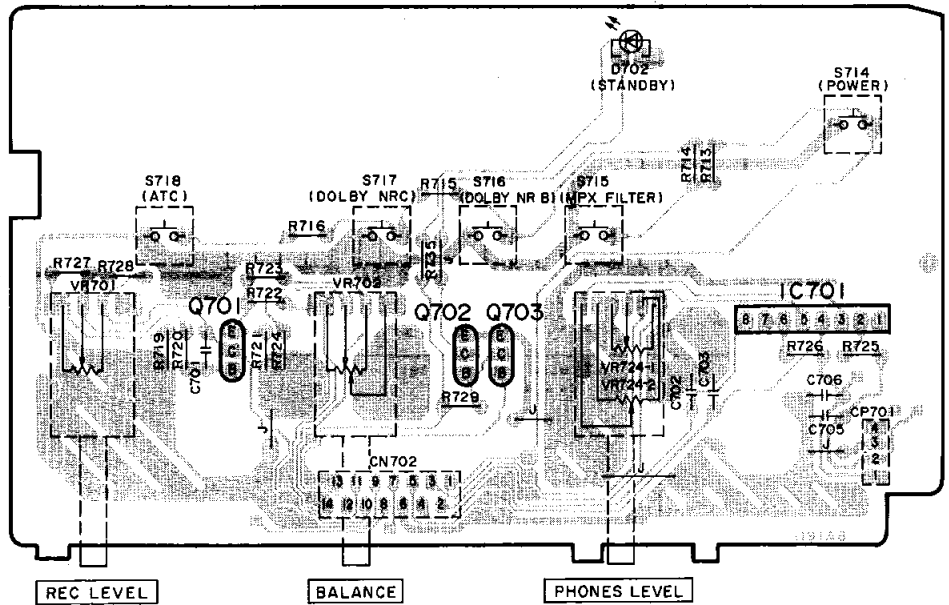

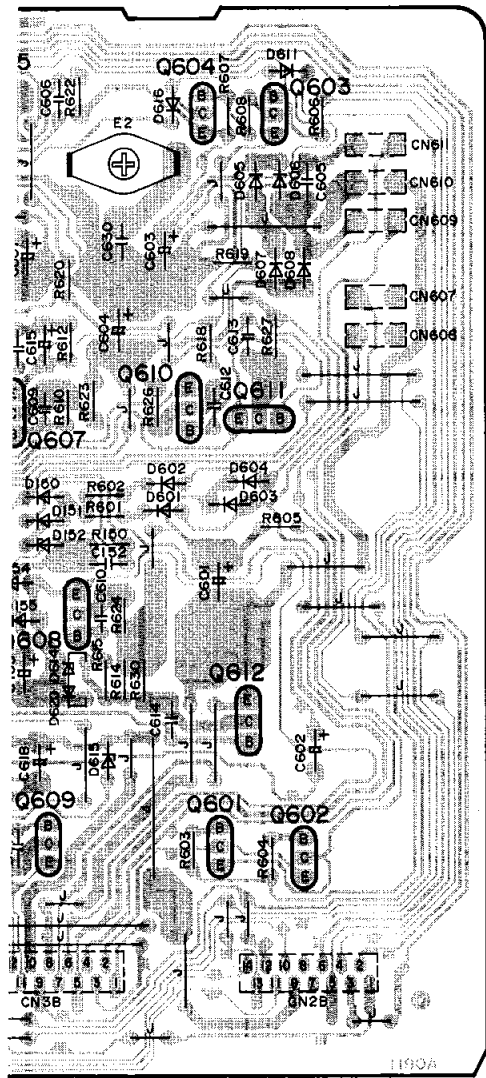

B MOTOR P.C.B. (REP18088-T)

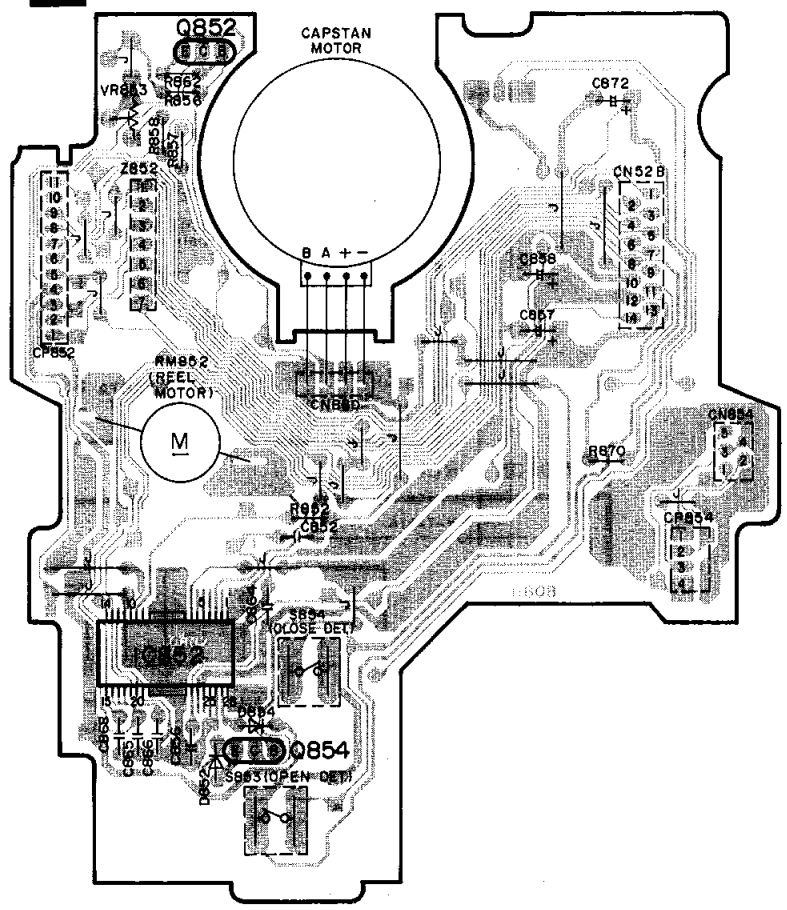



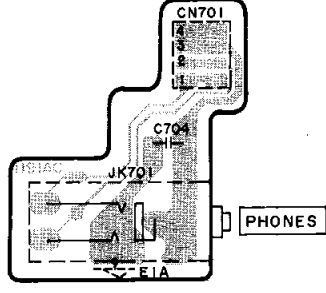

F HEADPHONES JACK P.C.B. (REP1848A-S)

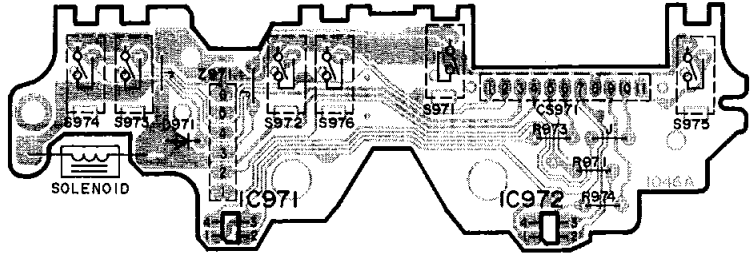

E MECHANISM P.C.B. (REP1656A)

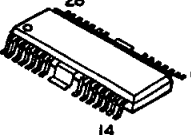
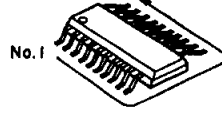
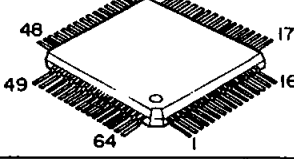
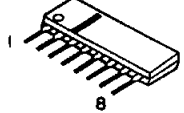
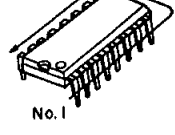
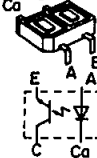
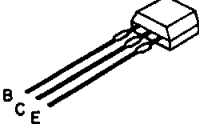
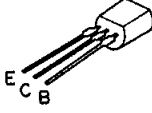

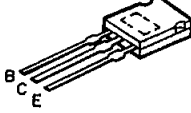
• Terminal guide of IC's, transistors and diodes

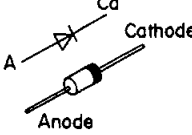
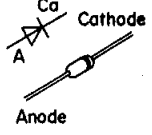
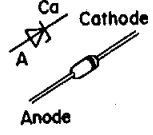
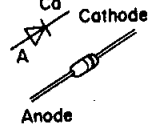
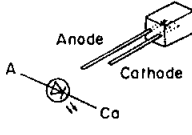
<p>BA4560FT1</p> 	<p>BA6265FP-E1</p> 	<p>No.1</p>  <table border="1" data-bbox="845 246 1093 414"> <tr><td>XLJ93LC46AFE</td><td>8 Pin</td></tr> <tr><td>XLU2040F-T2</td><td>16 Pin</td></tr> <tr><td>M62352FPE1</td><td>20 Pin</td></tr> <tr><td>AN7353S-E2</td><td>24 Pin</td></tr> <tr><td>AN7352S-E2</td><td>28 Pin</td></tr> <tr><td>AN7354SC-E2</td><td>42 Pin</td></tr> </table>	XLJ93LC46AFE	8 Pin	XLU2040F-T2	16 Pin	M62352FPE1	20 Pin	AN7353S-E2	24 Pin	AN7352S-E2	28 Pin	AN7354SC-E2	42 Pin	<p>M38123M4105F</p> 
XLJ93LC46AFE	8 Pin														
XLU2040F-T2	16 Pin														
M62352FPE1	20 Pin														
AN7353S-E2	24 Pin														
AN7352S-E2	28 Pin														
AN7354SC-E2	42 Pin														
<p>M5218AL</p> 	<table border="1" data-bbox="534 470 758 526"> <tr><td>AN7384N-SG</td><td>18 Pin</td></tr> <tr><td>UPC1297CA</td><td>18 Pin</td></tr> </table>  <p>No.1</p>	AN7384N-SG	18 Pin	UPC1297CA	18 Pin	<p>RVSGP2S24BC</p> 	 <p>DTA114ESTP DTC114ESTP DTC114YSTP</p>								
AN7384N-SG	18 Pin														
UPC1297CA	18 Pin														
<p>2SB621ARSTA 2SD592AQRSTA</p> 	 <p>2SA1309AIRTA 2SB1030AQSTA 2SC3311AIRTA 2SD1450RSTTA</p>	<p>2SB1357EFTA 2SD2037EFTA</p> 	<p>2SJ164PQRTA</p> 	<p>RL1N4003N02</p> 											
 <p>MA29WATA MA165TA MA167TA MA723TA RVD1SS133TA</p>	 <p>MTZJ5R1BTA MTZJ6R2BTA MTZJ6R8BTA MTZJ8R2CTA MTZJ20DTA</p>	<p>MA188TA</p> 	<p>LN873RP-C</p> 												

■ REPLACEMENT OF THE FOOT

1. Remove the 4 heat melted posts on the Bottom board ass'y with a pair of nippers or similar tool.
2. To replace the foot(RKA0053-A) on the Bottom board ass'y melt the 4 posts with a soldering iron or install it with a screw (XTB3+6J).

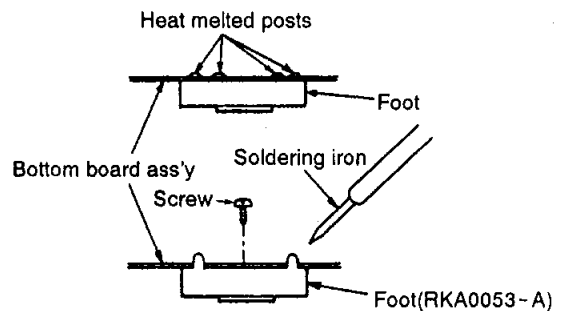



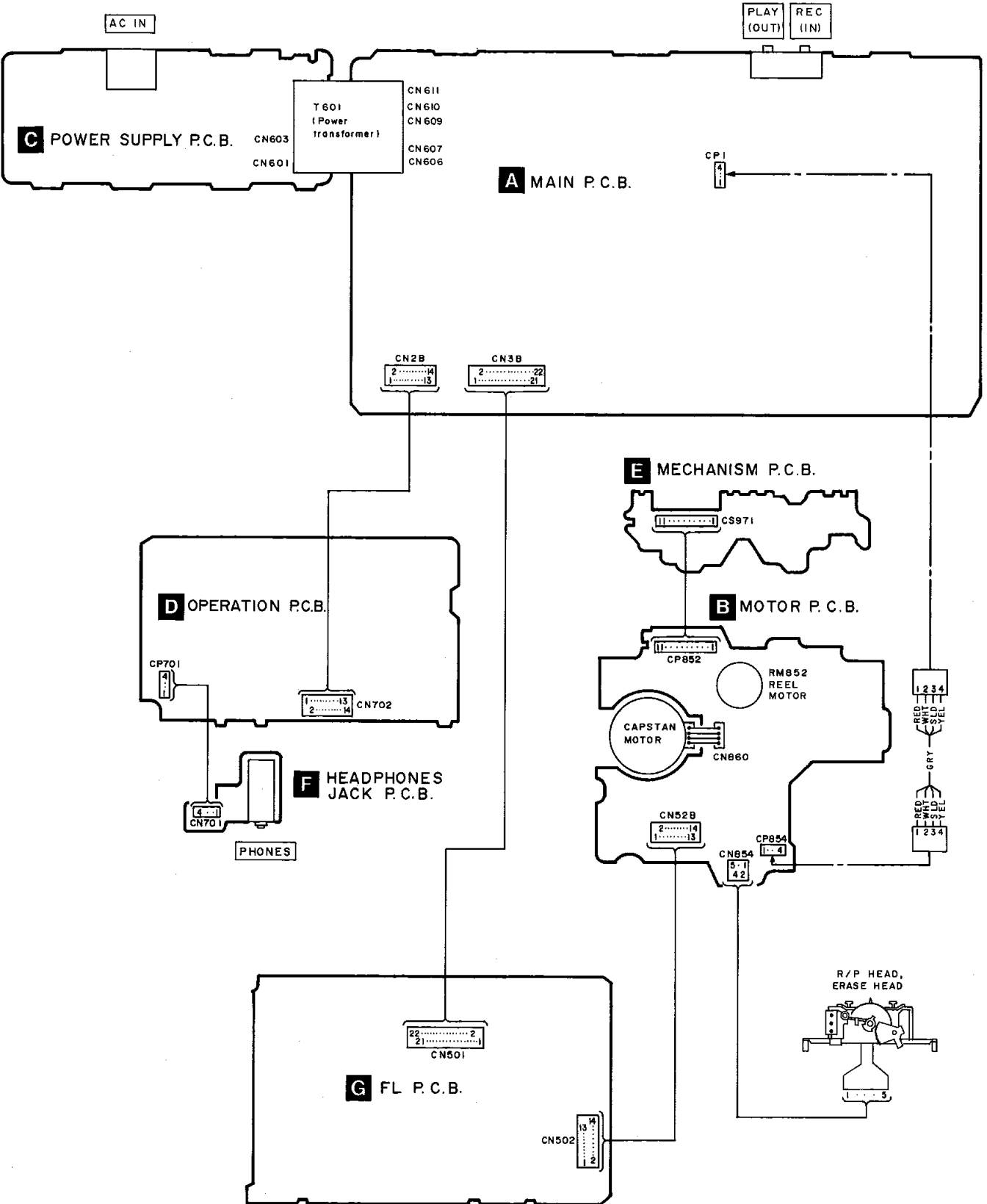







WIRING CONNECTION DIAGRAM



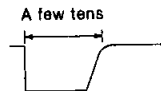

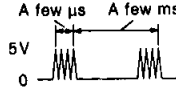
■ TERMINAL FUNCTION OF IC

• IC501 (M38123M4105F): MICROCOMPUTER

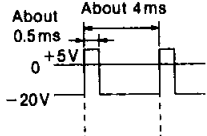
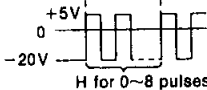
Pin No.	Mark	I/O Division	Function	Check point	※ Discription
1	KEY1	I	Key switch (STOP, FF, F. PLAY, R. PLAY, REW, REC, ARM, PAUSE, OPEN/CLOSE) input	IC501 ① pin	+5V without key input and 0V with the stop key ON. An analog value (0~5V) is used for each key ON.
2	KEY2	I	Key switch (COUNTER RESET, COUNTER MODE, MEMORY REPEAT/STOP, POWER, DOLBY B, DOLBY C, MPX, ATC ON/OFF, REVERSE MODE) input	IC501 ② pin	+5V without key input and 0V with the stop key ON. An analog value (0~5V) is used for each key ON.
3	METER-R	I	Rch indication level input	Connector CN501 ④ pin	0V with no signal and 1V with 0VU (-20dB) input in the REC or PAUSE mode. The voltage varies from 0 to 5V for different input levels.
4	METER-L	I	Lch indication level input	Connector CN501 ⑤ pin	
5	TEST		Test mode input	IC501 ⑤ pin	Normal: "H" (=4.8V) Test (Service) mode: "L" (=0V)
6	POWER	O	Power control output ON: "H", OFF: "L"	Connector CN501 ⑦ pin	Power ON: "H" (=5V) Power OFF: "L" (=0V)
7	—	—	Not used	—	—
8	MSP	I	TPS signal det. input ON: "L", OFF: "H"	Connector CN501 ⑧ pin	TPS mode No program: "H" (=5V) Programs: "L" (=0V)
9	—	—	Not used	—	—
10	DMT	O	Line out mute signal output ON: "L", OFF: "H"	Connector CN501 ⑨ pin	"L" (=0V) when sound is being produced in the play or REC mode and "H" (=2.5~5V) when no sound is produced in the stop of FF/REW mode.
11	ECS	O	E2PROM chip select signal ON: "H", OFF "L"	Connector CN503 ① pin CN503 ⑤ pin	 (ex...FOR ↔ REV PLAY mode is changed)
12	ECLK	O	E2PROM serial clock output ON: "L", OFF: "H"	Connector CN503 ② pin CN503 ④ pin	 (ex...FOR ↔ REV PLAY mode is changed) Waveform appears in response to 11 above.
13	EDAT	I/O	E2PROM serial data input/output	Connector CN503 ③ pin	 (ex...FOR ↔ REV PLAY mode is changed) Waveform appears in response to 11 above.
14	—	—	Not used	—	—
15	OSC	O	Audio signal for adjustment output	Connector CN501 ⑫ pin	Generated signals at approx. 400Hz, 10kHz and 3kHz (square wave (H and L, 0 and 5V) in REC mode during adjustment of ATC).
16	S STB	O	Strobe (load) output for the DA converter (IC151)	Connector CN501 ⑬ pin	Used to load output for the DA converter (IC151).

Pin No.	Mark	I/O Division	Function	Check point	※ Discription
17	REMOTE	I	Remocon signal input ON: "H", OFF: "L"	Z502 ① pin	H and L pulse waveform appears on the input of a remote control signal.
18	POF	I	Power off det. input ON: "H", OFF: "L"	Connector CN501 ② pin	 Rectified waveform at both 50 and 60Hz (clamping at 5V) The microprocessor goes into standby mode when this signal is removed.
19	RESET	I	Reset input ON: "L", OFF: "H"	Transistor Q501 collector	 Usually H (=5V) but L for a period of a few to a few tens of milliseconds is first plugged in when the player.
20	SDAT	O	Serial data output for DA converter (IC151)/serial-parallel converter (IC152) ON: "H", OFF: "L"	Connector CN501 ① pin	 Data output in response to 21
21	SCLK	O	Serial clock output for DA converter (IC151)/serial-parallel converter (IC152) ON: "H", OFF: "L"	Connector CN501 ③ pin	 Pulse signal is emitted only when a mode change occurs.
22	XIN	I	Microcomputer clock OSC terminal	Z501 ① pin terminal	 Oscillator waveform at 6MHz
23	XOUT	O	Microcomputer clock OSC terminal	Z501 ③ pin terminal	 Oscillator waveform at 6MHz
24	GND	—	Microcomputer GND	IC501 ④ pin	0V
25	—	—	Not used	—	—
26	MLAT1	O	Latch output for mechanism control ON: "H", OFF: "L"	Connector CN502 ⑧ pin	 Emitted only when mechanism mode changes.
27	MDAT	O	Serial data output for mechanism control ON: "H", OFF: "L"	Connector CN502 ⑨ pin	Serial data used to control the mechanism driver via IC852.
28	MCLK	O	Serial clock output for mechanism control ON: "H", OFF: "L"	Connector CN502 ⑩ pin	Emitted only when mechanism mode changes.
29 ┆ 46	P1 ┆ P18	O	FL meter segment output ON: "H", OFF: "L"	FL501 ⑦~⑭ pin	
47 ┆ 52	1G ┆ 6G	O	FL meter glid output ON: "H", OFF: "L"	FL501 ①~⑥ pin	 H for 0~8 pulses of duration approx. 0.5ms each.

Pin No.	Mark	I/O Division	Function	Check point	※ Discription
53	—	—	Not used	—	—
54	—	—	Not used	—	—
55	—	—	Not used	—	—
56	—	—	Not used	—	—
57	V _{DD}	—	Microcomputer terminal	Connector CN501 ⑫ pin	+5V, Backup
58	-VP	—	FL meter pull down voltage input terminal	Connector CN501 ⑪ pin	-20V
59	AV _{SS}	—	GND terminal (A/D)	Connector CN501 ⑩ pin	0V
60	V _{REF}	I	Reference power supply (+5V) (A/D)	Connector CN501 ⑨ pin	+5V
61	RPT	I	Reel pulse det. input (take up side)	Connector CN502 ⑬ pin	 <p>Changes within the 0 ↔ 3V range each time the take up reel is through approximately 30 degrees.</p>
62	AD01	I	Deck 2 Mechanism switch (FINH, CrO ₂ , Metal, OPEN/CLOSE) input	Connector CN502 ⑫ pin	No tape load: Approx. 4.1V Normal tape with tab: Apprxo. 0V Chrome tape with tab: 1.1V Metal tape with tab: Approx. 1.7V
63	RPS	I	Reel pulse det. Input (supply side)	Connector CN502 ⑭ pin	 <p>Changes within the 0 ↔ 3V range each time the take up reel is through approximately 30 degrees.</p>
64	AD02	I	Deck 2 Mechanism switch (MODE, RINH, HALF) input	Connector CN502 ⑪ pin	No tape load: Approx. 4.1V Normal tape with tab: Approx. 2.3V

1 2 3 4 5

■ CABINET PARTS LOCATION

A
B
C
D
E
F
G

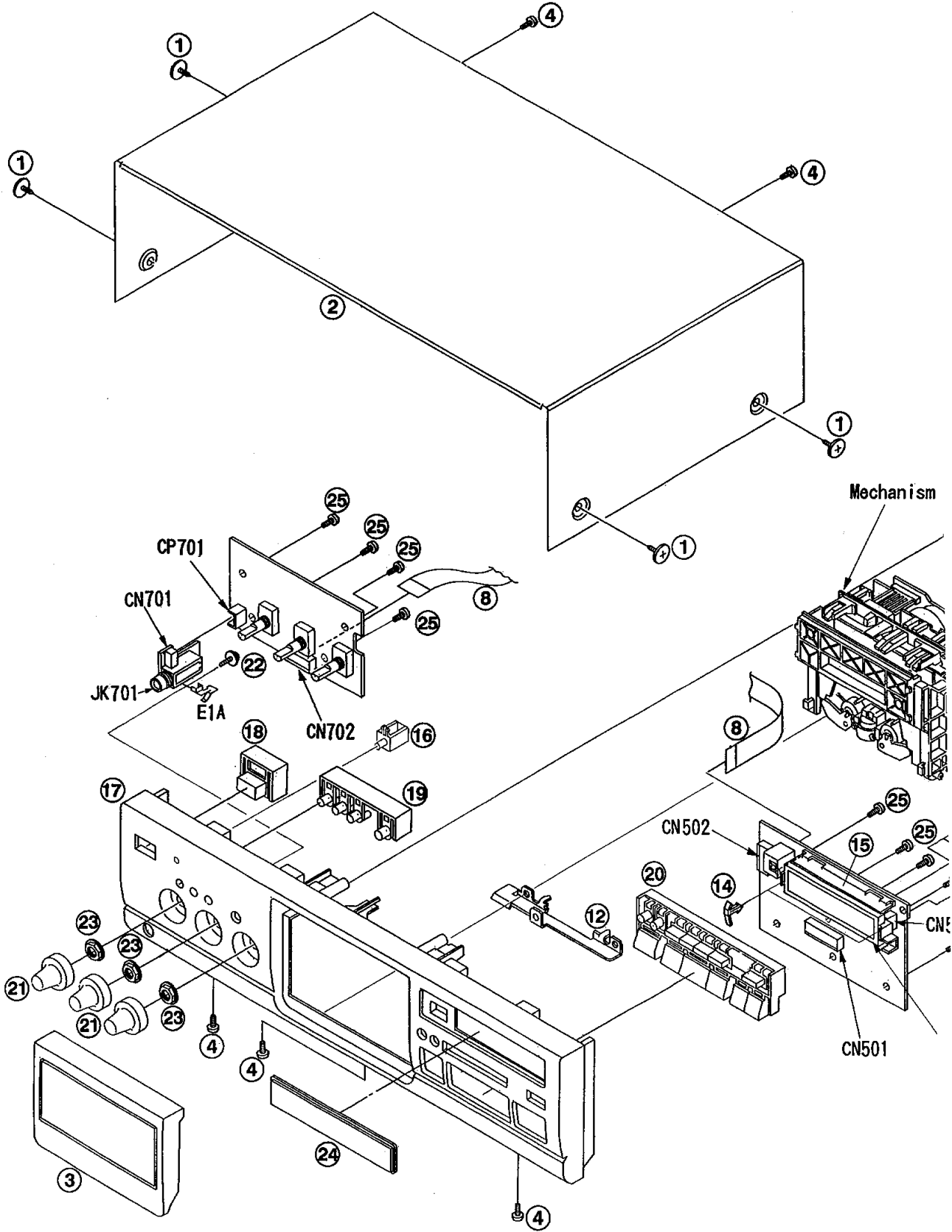

6

7

8

9

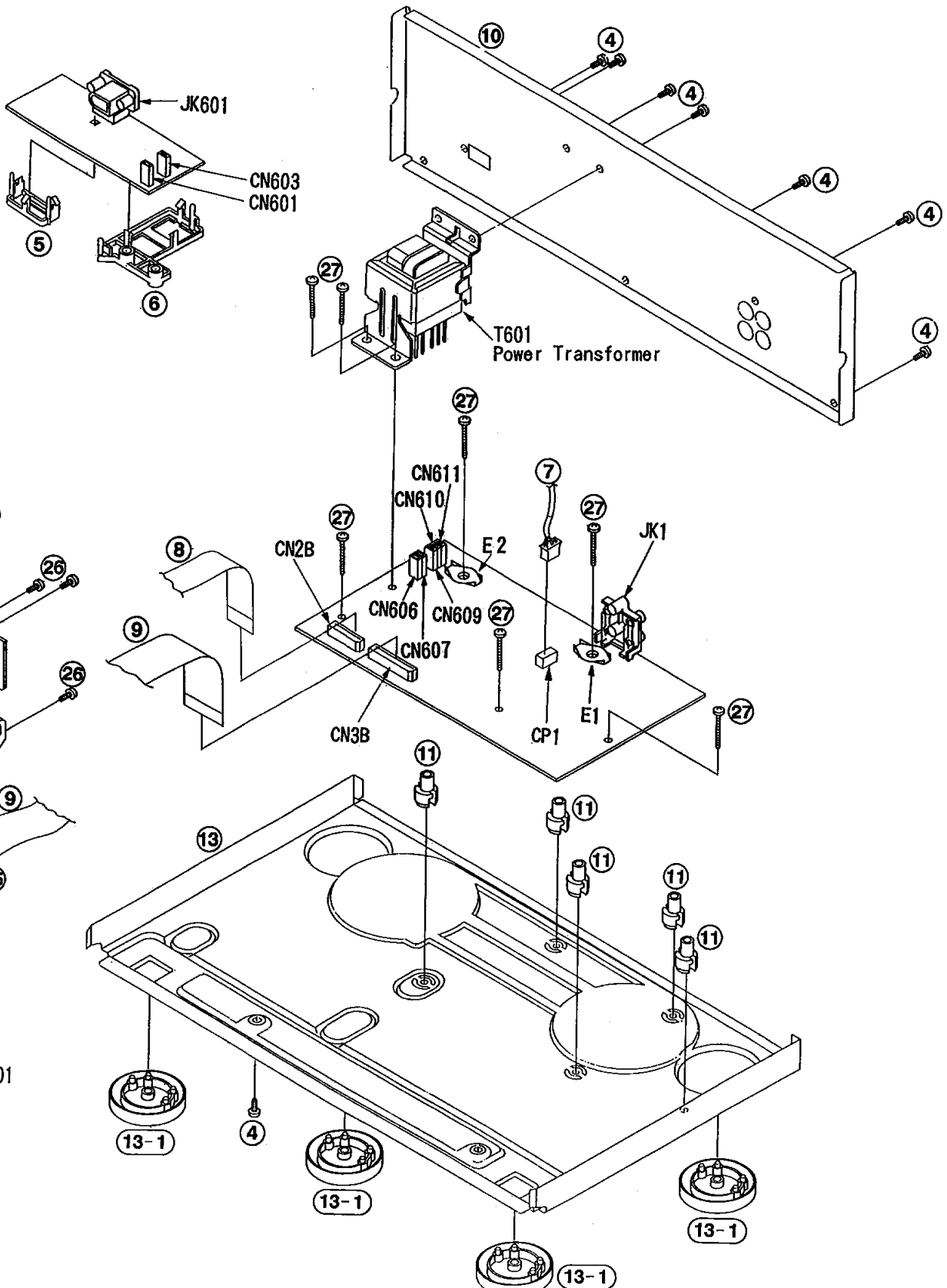

lit

26

26

9

25

3

5

L501

1

2

3

4

MECHANISM PARTS LOCATION

Note:

When changing mechanism parts, apply the specified grease to areas marked "x x" as shown in the drawing.

Ref. No.	Part Name	Part No.
①	FLOIL AK-152	SZZ0L18
②	SWAFLUID #56	RZZ0L02
③	MOLYCOAT EM-20L	RZZ0L05

A
B
C
D
E
F

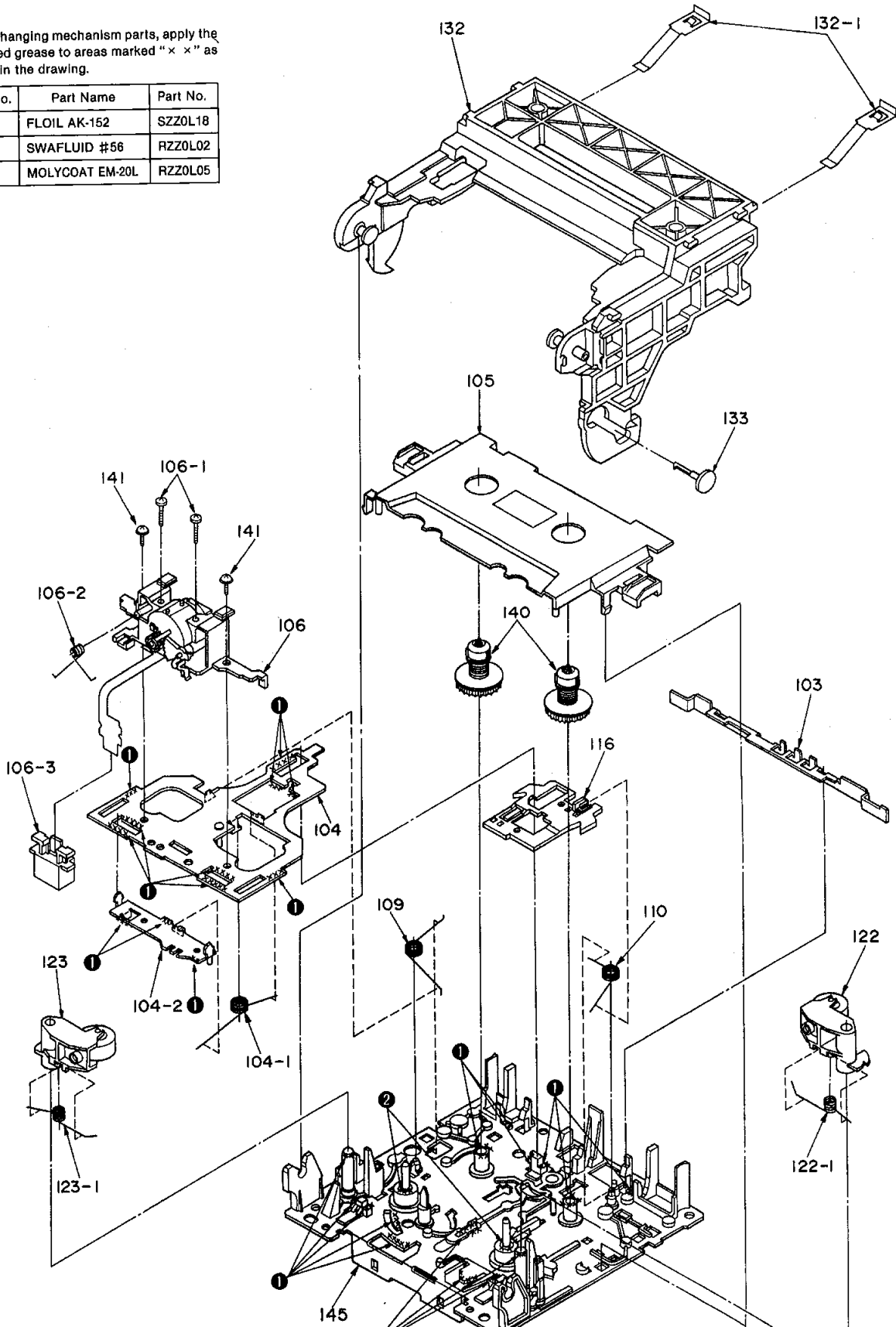

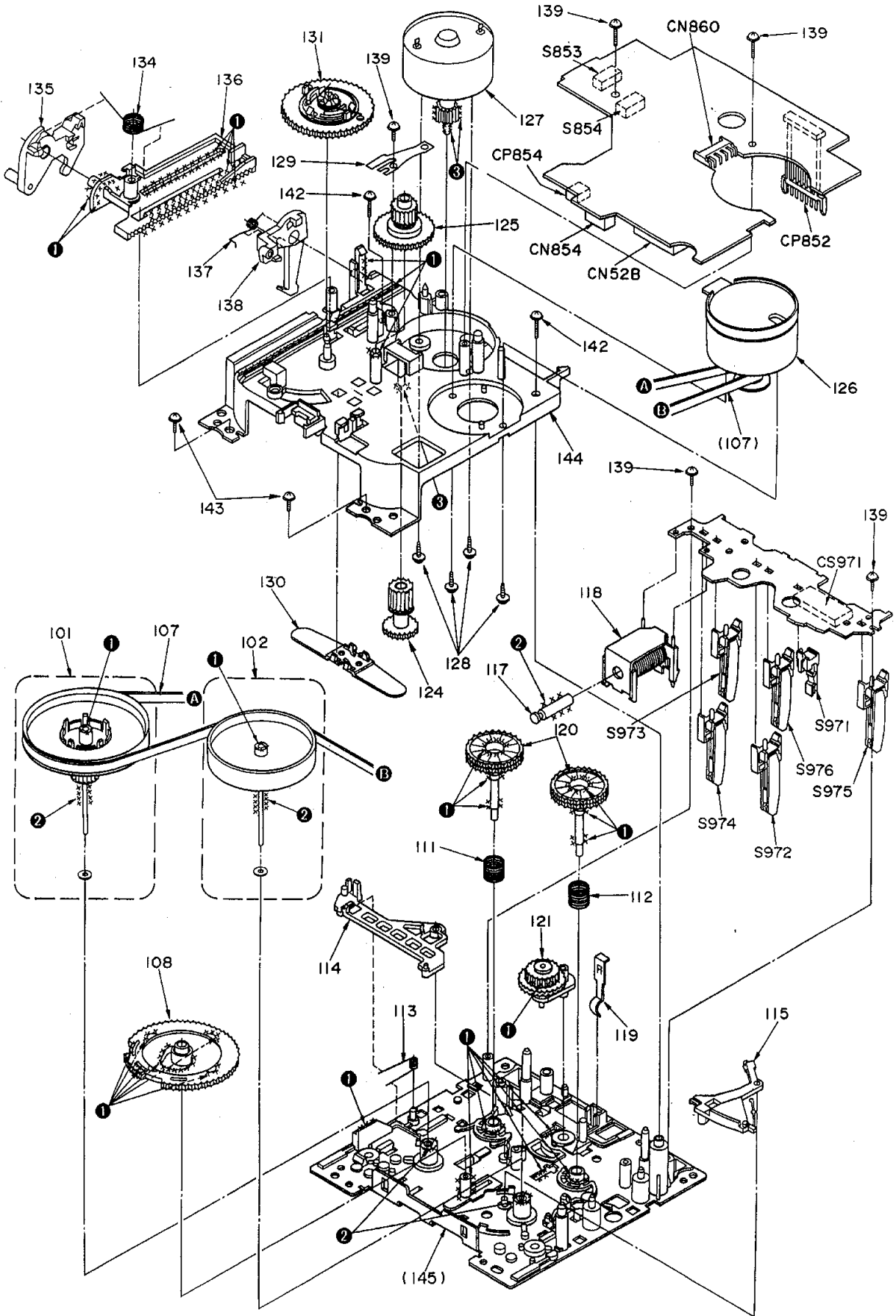

REPLACEMENT PARTS LIST

Ref. No.	Part No.	Part Name & Description	Remarks	Ref. No.	Part No.	Part Name & Description	Remarks
		MECHANISM PARTS		137	RMB0268	SPRING, HOLDER HOOK	
				138	RML0271A	HOLDER HOOK	
				139	XTW2+6S	SCREW	
101	RXF0040	FLYWHEEL(F) ASS'Y		140	RXR0018	REEL TABLE	
102	RXF0047	FLYWHEEL(R) ASS'Y		141	XTW2+5L	SCREW	
103	RML0272	SWITCH LEVER		142	XTW26+12S	SCREW	
104	RXQ0265	HEAD BASE ASS'Y		143	XTW26+6L	SCREW	
104-1	RMB0266-1	SPRING, FOR. /REV. SIDE ROD		144	RFKJSCH404AK	SUB CHASSIS ASS'Y	
104-2	RXM0036	FOR. /REV. SIDE ROD		145	RFKJSCH404BK	CHASSIS ASS'Y	
105	RGR0582-K	DRESSING PLATE					
106	RXQ0316-1	HEAD BLOCK(R/P)					
106-1	RHD17015	AZIMUTH ADJUSTMENT SCREW					
106-2	RMB0352	SPRING, HEAD HOLD					
106-3	RMQ0360A	CONNECTOR HOLDER					
107	RDV0015	BELT					
108	RDK0019A	MAIN GEAR					
109	RMB0261	SPRING, HEAD BASE					
110	RMB0262	SPRING, BRAKE ROD					
111	RMB0263	SPRING(F)					
112	RMB0264	SPRING(R)					
113	RUW1472A	SPRING, TRIGGER LEVER					
114	RML0267A	TRIGGER LEVER					
115	RML0268A	FOR. /REV. SIDE LEVER					
116	RMM0091A	BRAKE ROD					
117	RMS0398	MOVING IRON CORE					
118	RSJ0003	SOLENOID					
119	RUS6092C	SPRING, TAPE PRESSURE					
120	RXG0036	REEL GEAR					
121	RXL0106	IDLE GEAR					
122	RXP0052	PINCH ROLLER(F) ASS'Y					
122-1	RMB0259	SPRING, PINCH ROLLER(F)					
123	RXP0053	PINCH ROLLER(R) ASS'Y					
123-1	RMB0260	SPRING, PINCH ROLLER(R)					
124	RDG0206A-1	LOADING GEAR					
125	RDG0209A	INTERMEDIATE GEAR					
126	REM0036-1	CAPSTAN MOTOR					
127	REM0043	REEL MOTOR					
128	RHD26013	SCREW					
129	RMCO169	SHIELD PLATE					
130	RMQ0314A	SURASUTO SPACER					
131	RXG0037	FRICTION GEAR ASS'Y					
132	RYF0263-K	CASSETTE HOLDER					
132-1	RUS7572A	SPRING, TAPE PRESSURE					
133	RMQ0430	RIVET					
134	RMB0269	SPRING, DRIVE LEVER					
135	RML0270A-1	DRIVE LEVER					
136	RMQ0312A	DRIVE RACK					

Ref. No.	Part No.	Part Name & Description	Remarks	Ref. No.	Part No.	Part Name & Description	Remarks
		INTEGRATED CIRCUIT(S)		D150, 151	MA165	DIODE	
				D152	MTZJ5R1BTA	DIODE	△
				D154, 155	RL1N4003N02	DIODE	
IC1	AN7384N-SG	ELECTRIC VOLUME		D159	MA165	DIODE	
IC2	AN7352S-E2	PLAYBACK AMP		D301, 302	MTZJ6R8BTA	DIODE	
IC3	AN7353S-E2	REC EQ AMP		D303-307	MA165	DIODE	
IC151	M62352FPE1	12ch D/A CONVERTER		D401, 402	MA165	DIODE	
IC152	XLU2040F-T1	DATA CONTROL		D601, 602	MA165	DIODE	△
IC301	UPC1297CA	DOLBY HX PRO		D603-610	RL1N4003N02	DIODE	△
IC302	SVIBA4560FT1	E. CURRENT ADJ. CONTROL		D611	MA165	DIODE	
IC401	AN7354SC-E2	DOLBY B/C NR		D613	MTZJ8R2CTA	DIODE	△
IC501	M38123M4105F	MICROCOMPUTER		D614	MTZJ5R1BTA	DIODE	△
IC504	XLJ93LC46AFE	EEPROM		D615	MTZJ20DTA	DIODE	△
IC701	M5218L	HEADPHONES AMP		D616	MA165	DIODE	
IC852	BA6265FP-E1	MECHANISM CONTROL		D620	MA29WA	DIODE	
IC971	RVSGP2S24BC	PHOTO INTERRUPTER		D702	LN873RP-C	L. E. D.	
IC972	RVSGP2S24BC	PHOTO INTERRUPTER		D852	MA188TA	DIODE	
		TRANSISTOR(S)		D854	MA723TA	DIODE	
				D971	RVD1SS133TA	DIODE	
Q3, 4	2SJ164PQRTA	TRANSISTOR				VARIABLE RESISTOR(S)	
Q5	DTA114ESTP	TRANSISTOR		VR701	EVJ02FF02B15	REC LEVEL CONTROL	
Q6-8	2SC3311AIRTA	TRANSISTOR		VR702	EVJ02SF02G15	BALANCE CONTROL	
Q9, 10	2SJ164PQRTA	TRANSISTOR		VR704	EVJY10F02A24	PHONES LEVEL CONTROL	
Q301	2SA1309AIRTA	TRANSISTOR		VR853	EVNDCAA03B53	TAPE SPEED ADJ.	
Q302, 303	2SC3311AIRTA	TRANSISTOR				COIL(S)	
Q304	2SB621A-R	TRANSISTOR		L1, 2	SLQX303-1KT	COIL	
Q305	2SD592ANCQ	TRANSISTOR		L301, 302	SLO9B1-Z	COIL	
Q306	2SB1030AQSTA	TRANSISTOR		L303	SLO9B4-K	COIL (HX PRO ADJ.)	
Q401-406	2SC3311AIRTA	TRANSISTOR		L401, 402	RLM2B006T-K	COIL	
Q501	2SC3311AIRTA	TRANSISTOR				TRANSFORMER(S)	
Q601, 602	2SD1450RTA	TRANSISTOR		T601	RTP1K4B018-V	POWER TRANSFORMER	△
Q603	DTC114ESTP	TRANSISTOR				OSC. (S) AND COMBINATION(S)	
Q604	2SA1309AIRTA	TRANSISTOR		Z501	EFOEC6004T4	CERAMIC OSCILLATOR(6MHz)	
Q605	2SD2037EFTA	TRANSISTOR	△	Z502	RCDHC-278N	REMOTE SENSOR	
Q606	2SA1309AIRTA	TRANSISTOR		Z852	EXBF7L355SYV	COMBINATION PART	
Q607	2SB1357EFTA	TRANSISTOR	△	Z971	EXBF6L306SYV	COMBINATION PART	
Q608	2SD2037EFTA	TRANSISTOR	△			DISPLAY TUBE(S)	
Q609	2SB621A-R	TRANSISTOR	△	FL501	RSL0179-F	DISPLAY TUBE	
Q610	2SB1357EFTA	TRANSISTOR				SWITCH(ES)	
Q611	2SD2037EFTA	TRANSISTOR		S701	EVQ21405R	STOP	
Q612	2SD2037EFTA	TRANSISTOR	△				
Q701, 702	2SC3311AIRTA	TRANSISTOR					
Q703	DTC114ESTP	TRANSISTOR					
Q852	2SA1309AIRTA	TRANSISTOR					
Q854	2SD1450RTA	TRANSISTOR					
		DIODE(S)					
D3, 4	MA167	DIODE					
D5	MA165	DIODE					
D6	MTZJ6R2BTA	DIODE					

Ref. No.	Part No.	Part Name & Description	Remarks	Ref. No.	Part No.	Part Name & Description	Remarks
S702	EVQ21405R	F. -SIDE PLAYBACK		JK701	SJJ146B	HEADPHONES JACK	
S703	EVQ21405R	R. -SIDE PLAYBACK					
S704	EVQ21405R	F. F. SERCH<TPS>				GND PART(S)	
S705	EVQ21405R	REW. SERCH<TPS>					
S706	EVQ21405R	REC		E1	SNE1004-2	GND PLATE	
S707	EVQ21405R	PAUSE		E1A	SJSD165	GND SPRING, H. P. JACK	
S708	EVQ21405R	AUTO REC MUTE		E2	SNE1004-2	GND PLATE	
S709	EVQ21405R	OPEN/CLOSE					
S710	EVQ21405R	COUNTER RESET					
S711	EVQ21405R	COUNTER MODE					
S712	EVQ21405R	MEMORY STOP					
S713	EVQ21405R	REVERSE MODE					
S714	EVQ21405R	POWER					
S715	EVQ21405R	MPX FILTER					
S716	EVQ21405R	DOLBY NR B					
S717	EVQ21405R	DOLBY NR C					
S718	EVQ21405R	ATC					
S853	RSH1A024-U	OPEN DETECTION					
S854	RSH1A024-U	CLOSE DETECTION					
S971	RSH1A018-U	MODE					
S972	RSH1A019-U	HALF					
S973	RSH1A019-U	ATS					
S974	RSH1A019-U	R. REC. INH.					
S975	RSH1A019-U	F. REC. INH.					
S976	RSH1A019-U	ATS					
		CONNECTOR(S) AND SOCKET(S)					
CN2B	RJS1A6814	CONNECTOR (14P)					
CN3B	RJS1A6822	CONNECTOR (22P)					
CN52B	RJS1A6714	CONNECTOR (14P)					
CN501	RJS1A6222	CONNECTOR (22P)					
CN502	RJS1A6214-1	CONNECTOR (14P)					
CN503	SJS50581BB	SOCKET (5P)					
CN601	RJS1A1101T1	CONNECTOR (1P)					
CN603	RJS1A1101T1	CONNECTOR (1P)					
CN606, 607	RJS1A1101T1	CONNECTOR (1P)					
CN609-611	RJS1A1101T1	CONNECTOR (1P)					
CN701	RJU057W004	SOCKET (4P)					
CN702	RJS1A6214-1	CONNECTOR (14P)					
CN854	RJS2A0205-2S	CONNECTOR (5P)					
CN860	RJR0113	MOTOR CONNECTOR (4P)					
CP1	SJTD413	CONNECTOR (4P)					
CP701	RJT057W004-1	CONNECTOR (4P)					
CP852	RJT071H1A	CONNECTOR (11P)					
CP854	RJP4G17ZA	CONNECTOR (4P)					
CS971	RJU071H1M	SOCKET (11P)					
		JACK(S)					
JK1	SJF3069N	TERMINAL BOARD:REC/PLAY					
JK601	SJS9236	AC INLET	△				

RESISTORS AND CAPACITORS

Notes : * Capacity values are in microfarads (μF) unless specified otherwise, P=Pico-farads (pF) F=Farads (F)
 * Resistance values are in ohms, unless specified otherwise, 1 K=1,000 (OHM), 1 M=1,000k (OHM)

Ref. No.	Part No.	Values & Remarks	Ref. No.	Part No.	Values & Remarks	Ref. No.	Part No.	Values & Remarks
		RESISTORS	R315	ERDS2TJ561	1/4W 560	R624-626	ERD2FCVG100T	1/4W 10 Δ
			R316, 317	ERDS2TJ183T	1/4W 18K	R627	ERD2FCVJ6R8T	1/4W 6.8 Δ
			R318	ERDS2TJ393	1/4W 39K	R628	ERDS2TJ101	1/4W 100
R5, 6	ERDS2TJ225	1/4W 2.2M	R319	ERDS2TJ103	1/4W 10K	R630	ERD2FCVJ6R8T	1/4W 6.8 Δ
R7, 8	ERDS2TJ104	1/4W 100K	R320	ERDS2TJ332	1/4W 3.3K	R631, 632	ERD2FCVG330T	1/4W 33 Δ 1921
R10	ERDS2TJ225	1/4W 2.2M	R321	ERDS2TJ102	1/4W 1K	R642	ERDS2TJ561	1/4W 560
R13, 14	ERDS2TJ101	1/4W 100	R322, 323	ERDS2TJ100	1/4W 10	R701	ERDS2TJ821	1/4W 820
R15, 16	ERDS2EJ121	1/4W 120	R324	ERDS2TJ122	1/4W 1.2K	R702	ERDS2TJ102	1/4W 1K
R17, 18	ERDS2TJ474	1/4W 470K	R325	ERD2FCVG270T	1/4W 27 Δ	R703	ERDS2TJ122	1/4W 1.2K
R21, 22	ERDS2TJ273	1/4W 27K	R327	ERD2FCVG270T	1/4W 27 Δ	R704	ERDS2TJ152	1/4W 1.5K
R23, 24	ERDS2TJ183T	1/4W 18K	R328	ERDS2TJ222	1/4W 2.2K	R705	ERDS2TJ182	1/4W 1.8K
R25, 26	ERDS2TJ103	1/4W 10K	R329	ERDS2TJ473	1/4W 47K	R706	ERDS2TJ222	1/4W 2.2K
R27, 28	ERDS2TJ101	1/4W 100	R330	ERD2FCVG270T	1/4W 27 Δ	R707	ERDS2TJ332	1/4W 3.3K
R29	ERDS2TJ332	1/4W 3.3K	R332	ERDS2TJ102	1/4W 1K	R708	ERDS2TJ472	1/4W 4.7K
R30	ERDS2TJ472	1/4W 4.7K	R334	ERDS2TJ472	1/4W 4.7K	R709	ERDS2TJ821	1/4W 820
R31, 32	ERDS2TJ103	1/4W 10K	R401-404	ERDS2TJ684	1/4W 680K	R710	ERDS2TJ102	1/4W 1K
R33, 34	ERDS2TJ823T	1/4W 82K	R405, 406	ERDS2TJ152	1/4W 1.5K	R711	ERDS2TJ122	1/4W 1.2K
R35	ERDS2TJ124T	1/4W 120K	R407, 408	ERDS2TJ332	1/4W 3.3K	R712	ERDS2TJ152	1/4W 1.5K
R36	ERDS2TJ223	1/4W 22K	R409	ERDS2TJ223	1/4W 22K	R713	ERDS2TJ182	1/4W 1.8K
R37, 38	ERDS2TJ102	1/4W 1K	R410	ERDS2TJ103	1/4W 10K	R714	ERDS2TJ222	1/4W 2.2K
R39, 40	ERDS2TJ225	1/4W 2.2M	R411, 412	ERDS2TJ473	1/4W 47K	R715	ERDS2TJ332	1/4W 3.3K
R41, 42	ERDS2TJ183T	1/4W 18K	R413, 414	ERDS2TJ104	1/4W 100K	R716	ERDS2TJ472	1/4W 4.7K
R43, 44	ERDS2TJ393	1/4W 39K	R501, 502	ERDS2TJ331	1/4W 330	R719	ERDS2TJ562	1/4W 5.6K
R45, 46	ERDS2TJ394	1/4W 390K	R503-505	ERDS2TJ223	1/4W 22K	R720, 721	ERDS2TJ102	1/4W 1K
R47, 48	ERDS2TJ561	1/4W 560	R506	ERDS2TJ472	1/4W 4.7K	R722, 723	ERDS2TJ562	1/4W 5.6K
R49, 50	ERDS2TJ222	1/4W 2.2K	R507-510	ERDS2TJ103	1/4W 10K	R724	ERDS2TJ471	1/4W 470
R55	ERDS2TJ223	1/4W 22K	R511	ERDS2TJ471	1/4W 470	R725, 726	ERDS2TJ180T	1/4W 18
R56	ERDS2TJ332	1/4W 3.3K	R520-523	ERDS2TJ103	1/4W 10K	R727, 728	ERDS2TJ333	1/4W 33K
R59	ERDS2TJ393	1/4W 39K	R525	ERDS2TJ223	1/4W 22K	R729	ERDS2TJ103	1/4W 10K
R60	ERDS2TJ333	1/4W 33K	R528-531	ERDS2TJ103	1/4W 10K	R735	ERDS2EJ121	1/4W 120
R61, 62	ERDS2TJ562	1/4W 5.6K	R534, 535	ERDS2TJ683	1/4W 68K	R852	ERDS2TJ2R2T	1/4W 2.2
R63, 64	ERDS2TJ222	1/4W 2.2K	R536-538	ERDS2TJ223	1/4W 22K	R856	ERDS2TJ153	1/4W 15K
R67, 68	ERDS2TJ103	1/4W 10K	R540	ERDS2TJ223	1/4W 22K	R857	ERDS2TJ103	1/4W 10K
R69, 70	ERDS2TJ682T	1/4W 6.8K	R601-604	ERDS2TJ472	1/4W 4.7K	R858	ERDS2TJ392T	1/4W 3.9K
R80	ERDS2TJ561	1/4W 560	R605	ERDS2TJ1R0	1/4W 1.0	R862	ERDS2TJ474	1/4W 470K
R150	ERDS2TJ103	1/4W 10K	R606, 607	ERDS2TJ472	1/4W 4.7K	R870	ERDS2TJ271	1/4W 270
R173	ERDS2TJ221	1/4W 220	R608	ERDS2TJ103	1/4W 10K	R971	ERDS2TJ221	1/4W 220
R174-178	ERDS2TJ103	1/4W 10K	R609	ERDS2TJ102	1/4W 1K	R973, 974	ERDS2TJ393	1/4W 39K
R301, 302	ERDS2TJ153	1/4W 15K	R610	ERDS2TJ152	1/4W 1.5K			CAPACITORS
R303, 304	ERDS2TJ103	1/4W 10K	R611	ERDS2TJ101	1/4W 100			
R305, 306	ERDS2TJ154	1/4W 150K	R612	ERDS2TJ562	1/4W 5.6K	C5, 6	ECBT1H102KB5	50V 1000P
R307	ERDS2TJ100	1/4W 10	R613	ERDS2TJ682T	1/4W 6.8K	C7, 8	ECBA1H681KB5	50V 680P
R308	ERDS2TJ1R0	1/4W 1.0	R614	ERDS2TJ222	1/4W 2.2K	C10	ECEA1HKAOR1B	50V 0.1U
R309	ERDS2TJ100	1/4W 10	R615	ERDS2TJ101	1/4W 100	C11, 12	ECBT1E103ZF	25V 0.01U
R310	ERD2FCVG270T	1/4W 27 Δ	R616	ERDS2TJ222	1/4W 2.2K	C13, 14	ECQB1H682JF3	50V 6800P
R311	ERDS2TJ102	1/4W 1K	R617, 618	ERDS2TJ101	1/4W 100	C15, 16	ECEA1AKA101B	10V 100U
R312	ERDS2TJ682T	1/4W 6.8K	R619	ERDS2TJ331	1/4W 330	C17	ECEA1HKAR47B	50V 0.47U
R313	ERDS2TJ822	1/4W 8.2K	R620, 621	ERDS2TJ101	1/4W 100	C18	ECEA1CKA100B	16V 10U
R314	ERDS2TJ471	1/4W 470	R622, 623	ERD2FCVJ6R8T	1/4W 6.8 Δ			

Ref. No.	Part No.	Values & Remarks	Ref. No.	Part No.	Values & Remarks	Ref. No.	Part No.	Values & Remarks
C19, 20	ECKR2H121KB5	500V 120P	C311, 312	ECBT1H121KB5	50V 120P	C425, 426	ECBT1C682KR5	16V 6800P
C21, 22	ECEA1CKA100B	16V 10U	C313, 314	ECKR2H821KB5	500V 820P	C427	ECEA1CKA100B	16V 10U
C23, 24	ECEA1HKA2R2B	50V 2. 2U	C315, 316	ECBT1E223ZF	25V 0. 022U	C501, 502	ECEA1CKA100B	16V 10U
C25, 26	ECEA1HKAR47B	50V 0. 47U	C317	ECBT1H220J5	50V 22P	C503	ECEA1HKA010B	50V 1U
C27, 28	ECEA1CKN100B	16V 10U	C318	ECQP1153JZ	100V 0. 015U	C504	ECEA1EKA4R7B	25V 4. 7U
C29-32	ECEA1CKA100B	16V 10U	C320	ECBT1H220J5	50V 22P	C505, 506	ECEA1CKA100B	16V 10U
C33, 34	ECEA1CKA220B	16V 22U	C322	ECEA1AKA221B	10V 220U	C601	ECEA1EU222	25V 2200U Δ
C35	ECKR1H392KB5	50V 3900P	C323	ECBT1E103ZF	25V 0. 01U	C602	ECA1EM221B	25V 220U
C37, 38	ECEA1CKA220B	16V 22U	C324	ECEA1EKA4R7B	25V 4. 7U	C603, 604	ECA1EM102E	25V 1000U Δ
C39, 40	ECBT1E103ZF	25V 0. 01U	C325	ECKR1H392KB5	50V 3900P	C605	ECKR2H682PE	500V 6800P
C41, 42	ECEA1HKA010B	50V 1U	C326	ECEA1HKA0R1B	50V 0. 1U	C606	ECBT1E103ZF	25V 0. 01U
C43, 44	ECEA1CKA100B	16V 10U	C327	ECKW1H222KB5	50V 2200P	C607	ECEA1AKA221B	10V 220U
C61, 62	ECBT1H561KB5	50V 560P	C328	ECKD1H682KB	50V 6800P	C608-614	ECBT1E103ZF	25V 0. 01U
C63	ECEA1CKA100B	16V 10U	C329	ECKW1H222KB5	50V 2200P	C615	ECEA1CKA100B	16V 10U
C64	ECEA1HKA010B	50V 1U	C330	ECBT1E103ZF	25V 0. 01U	C616, 617	ECA1AM102B	10V 1000U
C67, 68	ECBT1C472KR5	16V 4700P	C332	ECBT1E103ZF	25V 0. 01U	C618	ECA1HM221B	50V 220U Δ
C151	ECEAOJKA221B	6. 3V 220U	C401, 402	ECBT1C222KR5	16V 2200P	C630	ECBT1E103ZF	25V 0. 01U
C152	ECBT1E103ZF	25V 0. 01U	C403, 404	ECBT1C182KR5	16V 1800P	C701-703	ECBT1E103ZF	25V 0. 01U
C153	ECEAOJU102	6. 3V 1000U	C405, 406	ECBT1C222KR5	16V 2200P	C704-706	ECBT1H104ZF5	50V 0. 1U
C154	ECBT1H331KB5	50V 330P	C407, 408	ECQV1H154JM3	50V 0. 15U	C852	ECBT1E223ZF	25V 0. 022U
C156	ECEA1HKA010B	50V 1U	C409, 410	ECEA1HKA010B	50V 1U	C856	ECBT1H104ZF5	50V 0. 1U
C175	ECBT1H101KB5	50V 100P	C411, 412	ECEA1HKA2R2B	50V 2. 2U	C857	ECEA1EKA101B	25V 100U
C301	ECBT1E103ZF	25V 0. 01U	C413, 414	ECEA1HKA010B	50V 1U	C858	ECEA1AKA101B	10V 100U
C302	ECEA1CKA100B	16V 10U	C415, 416	ECQB1H152JF3	50V 1500P	C864	ECBT1H104ZF5	50V 0. 1U
C303, 304	ECBT1C122KR5	16V 1200P	C417, 418	ECEA1HKAR47B	50V 0. 47U	C865, 866	ECBT1H101KB5	50V 100P
C305, 306	ECQB1H103JF3	50V 0. 01U	C419, 420	ECQB1H152JF3	50V 1500P	C868	ECBT1H101KB5	50V 100P
C307, 308	ECQB1H223JF3	50V 0. 022U	C421, 422	ECEA1HKAR47B	50V 0. 47U	C872	ECEAOJKA221B	6. 3V 220U
C309, 310	ECQV1H473JM3	50V 0. 047U	C423, 424	ECBT1H820KB5	50V 82P			

REPLACEMENT PARTS LIST

Ref. No.	Part No.	Part Name & Description	Remarks	Ref. No.	Part No.	Part Name & Description	Remarks
		PACKING MATERIAL				ACCESSORIES	
P1	RPG2015	PACKING CASE	(E, EG)	A1	RFKSSBX501E	INSTRUCTION MANUAL ASS'Y	(E)
P1	RPG2016	PACKING CASE	(EB)	A1	RFKSSBX501EG	INSTRUCTION MANUAL ASS'Y	(EG)
P2	RPN0697	CUSHION	(E, EG)	A1	RQT2367-B	INSTRUCTION MANUAL	(EB)
P2	PRN0698	CUSHION	(EB)	A2	RQA0013	WARRANTY CARD	
P3	RPQ0164	ACCESSORIES PAD		A3	RQC0169	SERVICENTER LIST	
P4	SPP723	PROTECTION COVER (THIS UNIT)		A4	RJA0019-2K	AC POWER SUPPLY CORD	(E, EG) Δ (SF)
P5	XZB25X34C03Y	PROTECTION BAG (F. B., ACC.)		A4	VJA0733	AC POWER SUPPLY CORD	(EB) Δ (SF)
P6	RPH0032	MIRROR SHEET	(EB)	A5	SJP2276	STEREO CONNECTION CABLE	

PACKAGING

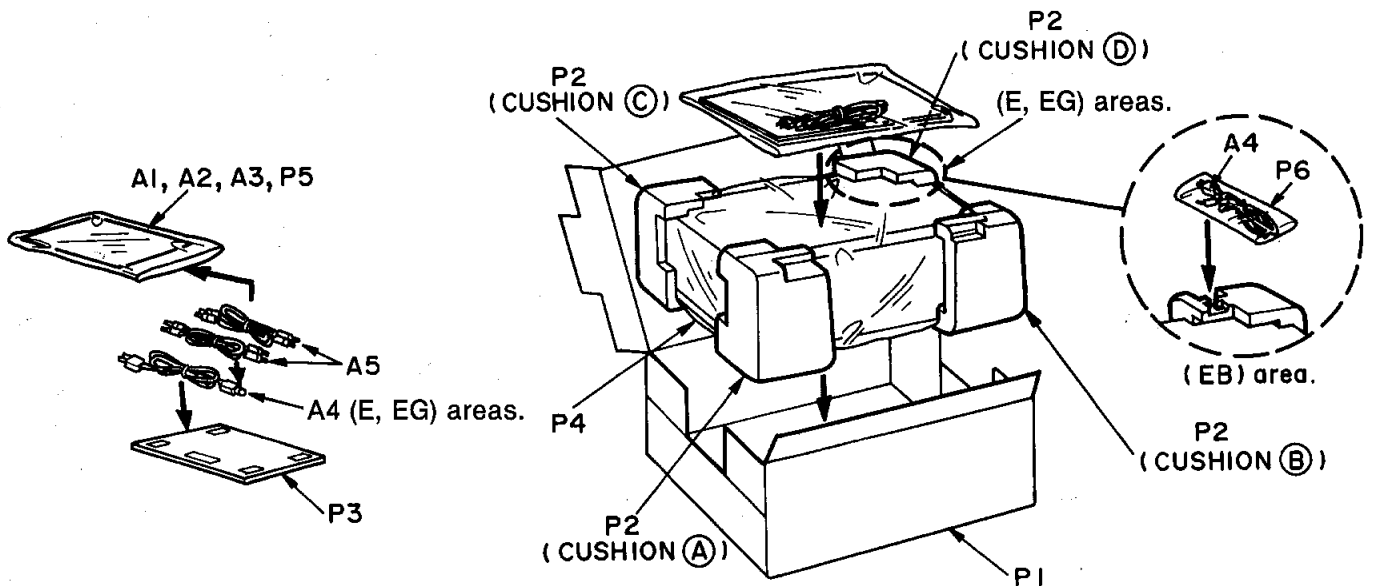

<CUSHION (A), (B), (C), (D) Part No.: RPN0697 (E, EG), PRN698 (EB)>