

# Service Manual

Computer Drive New Class A  
Stereo Integrated Amplifier

Amplifier  
**SU-V6X**

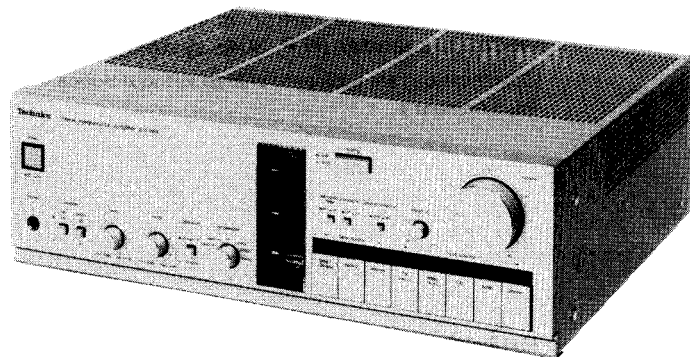

Color

(K).....Black Type  
(S).....Silver Type

Color	Area
(K)(S) [D]	Scandinavia
(K)(S) [EH]	Holland
(S) [EB]	Belgium
(K)(S) [EW]	Switzerland
(K)(S) [Ei]	Italy
(K)(S) [EK]	United Kingdom
(K)(S) [EF]	France
(K)(S) [XL]	Australia
(K)(S) [PA]	Far East PX
(K)(S) [PE]	European Military
(K)(S) [XA]	Asia, Latin America, Africa, Middle Near East and Oceania

Please use this manual together with the service manual for Model No.  
SU-V6X(K), Order No. HAD84042756C1.

## SPECIFICATIONS (DIN 45 500)

### ■ AMPLIFIER SECTION

20 Hz~20 kHz continuous power output both channels driven	2 × 100W (4Ω) 2 × 100W (8Ω)
40 Hz~16 kHz continuous power output both channels driven	2 × 100W (4Ω) 2 × 100W (8Ω)
1 kHz continuous power output both channels driven	2 × 100W (4Ω) 2 × 100W (8Ω)
Total harmonic distortion	
rated power at 20 Hz~20 kHz	0.007% (4Ω) 0.003% (8Ω)
rated power at 40 Hz~16 kHz	0.007% (4Ω) 0.003% (8Ω)
rated power at 1 kHz	0.0015% (4Ω) 0.001% (8Ω)
half power at 20 Hz~20 kHz	0.002% (8Ω)
half power at 1 kHz	0.001% (8Ω)
-26 dB power at 1 kHz	0.01% (4Ω)
50 mW power at 1 kHz	0.01% (4Ω)
Intermodulation distortion	
rated power at 250 Hz: 8 kHz=4:1, 4Ω	0.01%
rated power at 60 Hz: 7 kHz=4:1, SMPTE, 8Ω	0.007%
Power bandwidth	
both channels driven, -3 dB	5 Hz~70 kHz (4Ω, 0.03%) 5 Hz~70 kHz (8Ω, 0.02%)
Residual hum and noise	0.5 mV
Damping factor	40 (4Ω), 80 (8Ω)

### Input sensitivity and Impedance

PHONO MM	2.5 mV/47kΩ
MC	170 μV/220Ω
TUNER, CD, TV/AUX 1, VIDEO/AUX 2	150 mV/18kΩ
TAPE 1/DA TAPE, TAPE 2	150 mV/18kΩ
PHONO maximum input voltage (1 kHz, RMS)	
MM	210 mV
MC	15 mV

### S/N

rated power (4Ω)	
PHONO MM	78 dB (IHF, A: 88 dB, input 2.5 mV)
MC	72 dB (IHF, A: 72 dB, input 250 μV)
TUNER, CD, TV/AUX 1, VIDEO/AUX 2,	
TAPE 1/DA TAPE, TAPE 2	93 dB (IHF, A: 104 dB)
-26 dB power (4Ω)	
PHONO MM	72 dB
MC	68 dB
TUNER, CD, TV/AUX 1, VIDEO/AUX 2,	
TAPE 1/DA TAPE, TAPE 2	74 dB
50 mW power (4Ω)	
PHONO MM	68 dB
MC	67 dB
TUNER, CD, TV/AUX 1, VIDEO/AUX 2,	
TAPE 1/DA TAPE, TAPE 2	69 dB

### Frequency response

PHONO	RIAA standard curve ±0.5 dB (30 Hz~15 kHz)
TUNER, CD, TV/AUX 1, VIDEO/AUX 2,	
TAPE 1/DA TAPE, TAPE 2	0.7 Hz~140 kHz (-3 dB) +0, -0.2 dB (20 Hz~20 kHz)

# Technics

Panasonic Tokyo  
Matsushita Electric Industrial Co., Ltd.  
1-2, 1-chome, Shibakoen, Minato-ku,  
Tokyo 105 Japan

Matsushita Electric Trading Co., Ltd.  
P.O. Box 288, Central Osaka Japan

<b>Tone controls</b>		
<b>BASS</b>	50 Hz, +10 dB ~ -10 dB	
<b>TREBLE</b>	20 kHz, +10 dB ~ -10 dB	
<b>Subsonic filter</b>	30 Hz, -6 dB/oct.	
<b>Loudness control (volume at -30 dB)</b>	50 Hz, +9 dB	
<b>Output voltage and impedance</b>		
<b>REC OUT</b>	150 mV	
<b>Channel balance, CD, AUX 1, 2</b>	250 Hz ~ 6,300 Hz	±1 dB
<b>Channel separation, CD, AUX 1, 2</b>	1 kHz	55 dB
<b>Headphones output level and impedance</b>	670 mV/330Ω	
<b>Load impedance</b>		
<b>MAIN or REMOTE</b>	4Ω ~ 16Ω	
<b>MAIN and REMOTE</b>	8Ω ~ 16Ω	

## TECHNISCHE DATEN

(DIN 45 500)

### ■ VERSTÄRKERTEIL

<b>Dauerton-Ausgangsleistung bei 20 Hz ~ 20 kHz</b>		
<b>beide Kanäle angesteuert</b>	2 × 100W (4 Ω)	
	2 × 100W (8 Ω)	
<b>Dauerton-Ausgangsleistung bei 40 Hz ~ 16 kHz</b>		
<b>beide Kanäle angesteuert</b>	2 × 100W (4 Ω)	
	2 × 100W (8 Ω)	
<b>Dauerton-Ausgangsleistung bei 1 kHz</b>		
<b>beide Kanäle angesteuert</b>	2 × 100W (4 Ω)	
	2 × 100W (8 Ω)	
<b>Gesamtklirrfaktor</b>		
<b>Nennleistung bei 20 Hz ~ 20 kHz</b>	0,007% (4 Ω)	
	0,003% (8 Ω)	
<b>Nennleistung bei 40 Hz ~ 16 kHz</b>	0,007% (4 Ω)	
	0,003% (8 Ω)	
<b>Nennleistung bei 1 kHz</b>	0,0015% (4 Ω)	
	0,001% (8 Ω)	
<b>halbe Nennleistung bei 20 Hz ~ 20 kHz</b>	0,002% (8 Ω)	
<b>halbe Nennleistung bei 1 kHz</b>	0,001% (8 Ω)	
<b>-26 dB Leistung bei 1 kHz</b>	0,01% (4 Ω)	
<b>50 mW Leistung bei 1 kHz</b>	0,01% (4 Ω)	
<b>Intermodulationsfaktor</b>		
<b>Nennleistung bei 250 Hz: 8 kHz = 4:1, 4 Ω</b>	0,01%	
<b>Nennleistung bei 60 Hz: 7 kHz = 4:1, nach SMPTE, 8 Ω</b>	0,007%	
<b>Leistungsbandbreite</b>		
<b>beide Kanäle angesteuert bei -3 dB</b>	5 Hz ~ 70 kHz (4 Ω, 0,03%)	
	5 Hz ~ 70 kHz (8 Ω, 0,02%)	
<b>Restbrumm und Geräusch</b>	0,5 mV	
<b>Dämpfungsfaktor</b>	40 (4 Ω), 80 (8 Ω)	
<b>Eingangsempfindlichkeit und -impedanz</b>		
<b>Phono MM</b>	2,5 mV/47 kΩ	
<b>MC</b>	170 μV/220 Ω	
<b>Tuner, CD, TV/AUX 1, Video/AUX 2</b>	150 mV/18 kΩ	
<b>Tape 1/Digitaltonband, Tape 2</b>	150 mV/18 kΩ	
<b>Maximale TA-Eingangsspannung (1 kHz, eff.)</b>		
<b>MM</b>	210 mV	
<b>MC</b>	15 mV	
<b>Tuner, CD, TV/AUX 1, Video/AUX 2, Tape 1/Digitaltonband, Tape 2</b>	74 dB	
<b>50 mW Leistung (4 Ω)</b>		
<b>Phono MM</b>	68 dB	
<b>MC</b>	67 dB	
<b>Tuner, CD, TV/AUX 1, Video/AUX 2, Tape 1/Digitaltonband, Tape 2</b>	69 dB	
<b>Frequenzgang</b>		
<b>Phono</b>	RIAA-Standardkurve ±0,5 dB (30 Hz ~ 15 kHz)	
<b>Tuner, CD, TV/AUX 1, Video/AUX 2, Tape 1/Digitaltonband, Tape 2</b>	0,7 Hz ~ 140 kHz (-3 dB), +0, -0,2 dB (20 Hz ~ 20 kHz)	

### ■ GENERAL

<b>Power consumption</b>	580W
<b>Power supply</b>	AC 50 Hz/60 Hz, 110V/120V/220V/240V
<b>Dimensions (W×H×D)</b>	430 × 142 × 380 mm (16-15/16" × 5-9/16" × 14-15/16")
<b>Weight</b>	11 kg (24.2 lb.)

#### Note:

Total harmonic distortion is measured by the digital spectrum analyzer (H.P. 3045 system).

(Specifications are subject to change without notice for further improvement.)

### Geräuschspannungsabstand

<b>Nennleistung (4 Ω)</b>	
<b>Phono MM</b>	78 dB (nach IHF, A: 88 dB, Eingang 2,5 mV)
<b>MC</b>	72 dB (nach IHF, A: 72 dB, Eingang 250 μV)
<b>Tuner, CD, TV/AUX 1, Video/AUX 2, Tape 1/Digitaltonband, Tape 2</b>	93 dB (nach IHF, A: 104 dB)

#### -26 dB Leistung (4 Ω)

<b>Phono MM</b>	72 dB
<b>MC</b>	68 dB

### Klangregler

<b>Baßregler (BASS)</b>	50 Hz, +10 dB ~ -10 dB
<b>Höhenregler (TREBLE)</b>	20 kHz, +10 dB ~ -10 dB
<b>Tiefenfilter</b>	30 Hz, -6 dB/Okt.

### Lautstärkekorrektur (Loudness)

<b>(bei -30 dB Ausgangsleistung)</b>	50 Hz, +9 dB
--------------------------------------	--------------

### Ausgangsspannung und -impedanz

<b>Aufnahmeausgang (REC OUT)</b>	150 mV
----------------------------------	--------

### Kanalabweichung (CD, AUX 1, 2, 250 Hz ~ 6300 Hz)

	±1 dB
--	-------

### Übersprechdämpfung (CD, AUX 1, 2, 1 kHz)

	55 dB
--	-------

### Kopfhörerpegel und -impedanz

	670 mV/330 Ω
--	--------------

### Lautsprecherimpedanz

<b>MAIN oder REMOTE</b>	4 Ω ~ 16 Ω
<b>MAIN und REMOTE</b>	8 Ω ~ 16 Ω

### ■ ALLGEMEINE DATEN

<b>Leistungsaufnahme</b>	580 W
<b>Netzspannung</b>	Wechselstrom 50 Hz/60 Hz, 110V/120V/220V/240V
<b>Abmessungen (B×H×T)</b>	430 × 142 × 380 mm
<b>Gewicht</b>	11 kg

#### Bemerkung:

Der Gesamtklirrfaktor wurde mit einem digitalen Rauschspektrometer (Anlage H.P. 3045) gemessen.

(Spezifikationen Können infolge von Verbesserungen ohne Ankündigung geändert werden.)

# CARACTERISTIQUES

(DIN 45 500)

## ■ SECTION AMPLIFICATEUR

**Puissance de sortie continue de 20 Hz~20 kHz,**  
les deux canaux en circuit  
2 × 100W (4Ω)  
2 × 100W (8Ω)

**Puissance de sortie continue de 40 Hz~16 kHz,**  
les deux canaux en circuit  
2 × 100W (4Ω)  
2 × 100W (8Ω)

**Puissance de sortie continue à 1 kHz**  
les deux canaux en circuit  
2 × 100W (4Ω)  
2 × 100W (8Ω)

**Distorsion harmonique totale**  
à puissance nominale (20 Hz~20 kHz) 0,007% (4Ω)  
0,003% (8Ω)  
à puissance nominale (40 Hz~16 kHz) 0,007% (4Ω)  
0,003% (8Ω)  
à puissance nominale (1 kHz) 0,0015% (4Ω)  
0,001% (8Ω)  
à demi-puissance (20 Hz~20 kHz) 0,002% (8Ω)  
à demi-puissance (1 kHz) 0,001% (8Ω)  
puissance de -26 dB à 1 kHz 0,01% (4Ω)  
puissance de 50 mW à 1 kHz 0,01% (4Ω)

**Distorsion d'intermodulation**  
à puissance nominale à 250 Hz: 8 kHz=4:1, 4Ω 0,01%  
à puissance nominale à 60 Hz: 7 kHz=4:1, SMPTE, 8Ω 0,007%

**Réponse de fréquences**  
les deux canaux en circuit, -3 dB  
5 Hz~70 kHz (4Ω, 0,03%)  
5 Hz~70 kHz (8Ω, 0,02%)

**Bruit et ronflement résiduels** 0,5 mV

**Coefficient d'amortissement** 40 (4Ω), 80 (8Ω)

**Sensibilité et impédance d'entrée**  
PHONO MM 2,5 mV/47kΩ  
MC 170 μV/220Ω  
SYNTHONISATEUR, DISQUE COMPACT, TV/AUX 1,  
VIDEO/AUX 2 (TUNER, CD, TV/AUX 1, VIDEO/AUX 2)  
150 mV/18kΩ  
BANDE 1, (TAPE 1/DA TAPE, TAPE 2) 150 mV/18kΩ

**PHONO (tension d'entrée maximum, 1 kHz RMS)**  
MM 210 mV  
MC 15 mV

**Réponse de fréquence**  
PHONO Courbe nominale RIAA  
±0,5 dB (30 Hz~15 kHz)

**SYNTHONISATEUR, DISQUE COMPACTO, TV/AUX 1,  
VIDEO/AUX 2, BANDE 1/DIGITALE, BANDE 2  
(TUNER, CD, TV/AUX 1, VIDEO/AUX 2,  
TAPE 1/DA TAPE, TAPE 2)**  
0,7 Hz~140 kHz (-3 dB)  
+0, -0,2 dB (20 Hz~20 kHz)

**Réglage de la tonalité**  
BASSES (BASS) 50 Hz, +10 dB~ -10 dB  
AIGUS (TREBLE) 20 kHz, +10 dB~ -10 dB

**Filtre subsonique** 30 Hz, -6 dB/oct.

## Signal/Bruit

à puissance nominale (4Ω)  
PHONO MM 78 dB (IHF, A: 88 dB, entrée 2,5 mV)  
MC 72 dB (IHF, A: 72 dB, entrée 250 μV)  
SYNTHONISATEUR, DISQUE COMPACTO, TV/AUX 1,  
VIDEO/AUX 2, BANDE 1/DIGITALE, BANDE 2  
(TUNER, CD, TV/AUX 1, VIDEO/AUX 2,  
TAPE 1/DA TAPE, TAPE 2)  
93 dB (IHF, A: 104 dB)

puissance de -26 dB (4Ω)  
PHONO MM 72 dB  
MC 68 dB  
SYNTHONISATEUR, DISQUE COMPACTO, TV/AUX 1,  
VIDEO/AUX 2, BANDE 1/DIGITALE, BANDE 2  
(TUNER, CD, TV/AUX 1, VIDEO/AUX 2,  
TAPE 1/DA TAPE, TAPE 2) 74 dB

puissance de 50 mW (4Ω)  
PHONO MM 68 dB  
MC 67 dB  
SYNTHONISATEUR, DISQUE COMPACTO, TV/AUX 1,  
VIDEO/AUX 2, BANDE 1/DIGITALE, BANDE 2  
(TUNER, CD, TV/AUX 1, VIDEO/AUX 2,  
TAPE 1/DA TAPE, TAPE 2) 69 dB

**Compensateur physiologique (volume à -30 dB)**  
50 Hz, +9 dB

**Tension de sortie et impédance**  
SORTIE ENREGISTREMENT (REC OUT) 150 mV

**Equilibrage des canaux, CD, AUX 1, 2**  
250 Hz~6 300 Hz ±1 dB

**Séparation des canaux, CD, AUX 1, 2 1 kHz** 55 dB

**Niveau de sortie des casques et impédance** 670 mV/330Ω

**Impédance de charge**  
PRINCIPALE ou AUXILIAIRE (MAIN or REMOTE)  
4Ω~16Ω  
PRINCIPALE et AUXILIAIRE (MAIN and REMOTE)  
8Ω~16Ω

## ■ DIVERS

**Consommation** 580W

**Alimentation** CA 50 Hz/60 Hz, 110V/120V/220V/240V

**Dimensions (L×H×Pr)** 430 × 142 × 380 mm

**Poids** 11 kg

### Remarques:

- On mesure la distorsion harmonique totale au moyen d'un analyseur de spectre digital (Système H.P. 3045).
- La Société NATIONAL-PANASONIC-FRANCE, importateur du matériel MATSUSHITA-ELECTRIC déclare que cet appareil est conforme aux prescriptions de la directive 76/889/C.E.E. (arrêté 14 Janvier 1980).

(Sujet à changement sans préavis.)

## ESPECIFICACIONES (DIN 45 500)

### SECCION AMPLIFICADOR

<b>Potencia continua de 20 Hz~20 kHz en ambos canales</b>	2 × 100W (4Ω)
	2 × 100W (8Ω)
<b>Potencia continua de 40 Hz~16 kHz en ambos canales</b>	2 × 100W (4Ω)
	2 × 100W (8Ω)
<b>Potencia continua de 1 kHz en ambos canales</b>	2 × 100W (4Ω)
	2 × 100W (8Ω)

<b>Distorsión armónica total</b>	
potencia de régimen a 20 Hz~20 kHz	0,007% (4Ω) 0,003% (8Ω)
potencia de régimen a 40 Hz~16 kHz	0,007% (4Ω) 0,003% (8Ω)
potencia de régimen a 1 kHz	0,0015% (4Ω) 0,001% (8Ω)
mitad de potencia a 20 Hz~20 kHz	0,002% (8Ω)
mitad de potencia a 1 kHz	0,001% (8Ω)
-26 dB de potencia a 1 kHz	0,01% (4Ω)
50 mW de potencia a 1 kHz	0,01% (4Ω)

<b>Distorsión por intermodulación</b>	
potencia de régimen a 250 Hz: 8 kHz=4:1, 4Ω	0,01%
potencia de régimen a 60 Hz: 7 kHz=4:1, SMPTE, 8Ω	0,007%

<b>Ancho de banda de potencia en ambos canales, -3 dB</b>	5 Hz~70 kHz (4Ω, 0,03%)
	5 Hz~70 kHz (8Ω, 0,02%)

**Zumbido residual y ruido** 0,5 mV

**Factor de amortiguamiento** 40 (4Ω), 80 (8Ω)

#### Sensibilidad e impedancia de entrada

<b>TOCADISC. (PHONO) MM</b>	2,5 mV/47kΩ
<b>MC</b>	170 μV/220Ω

<b>SINTON., DISCO COMPACTO, TV/AUX. 1, VIDEO/AUX. 2 (TUNER, CD, TV/AUX 1, VIDEO/AUX 2)</b>	150 mV/18kΩ
<b>GRAB. 1/DIGITAL, GRAB. 2. (TAPE 1/DA TAPE, TAPE 2)</b>	150 mV/18kΩ

<b>Voltaje máximo de entrada de PHONO (1 kHz, RMS)</b>	
<b>MM</b>	210 mV
<b>MC</b>	15 mV

<b>Respuesta de frecuencia</b>	
<b>TOCADISC. (PHONO)</b>	curva RIAA estándar ±0,5 dB (30 Hz~15 kHz)

<b>SINTON., DISCO COMPACTO, TV/AUX. 1, VIDEO/AUX. 2, GRAB. 1/DIGITAL, GRAB. 2 (TUNER, CD, TV/AUX 1, VIDEO/AUX 2, TAPE 1/DA TAPE, TAPE 2)</b>	0,7 Hz~140 kHz (-3 dB), +0, -0,2 dB (20 Hz~20 kHz)
--	--

<b>Controles de tono</b>	
<b>BAJOS (BASS)</b>	50 Hz, +10 dB~ -10 dB
<b>AGUDOS (TREBLE)</b>	20 kHz, +10 dB~ -10 dB

#### Relación de señal a ruido

potencia de régimen (4Ω)  
**TOCADISC. (PHONO)**

<b>MM</b>	78 dB (IHF, A: 88 dB, entrada 2,5 mV)
<b>MC</b>	72 dB (IHF, A: 72 dB, entrada 250 μV)

**SINTON., DISCO COMPACTO, TV/AUX. 1, VIDEO/AUX. 2, GRAB. 1/DIGITAL, GRAB. 2 (TUNER, CD, TV/AUX 1, VIDEO/AUX 2, TAPE 1/DA TAPE, TAPE 2)** 93 dB (IHF, A: 104 dB)

-26 dB de potencia (4Ω)  
**TOCADISC. (PHONO) MM** 72 dB  
**MC** 68 dB

**SINTON., DISCO COMPACTO, TV/AUX. 1, VIDEO/AUX. 2, GRAB. 1/DIGITAL, GRAB. 2 (TUNER, CD, TV/AUX 1, VIDEO/AUX 2, TAPE 1/DA TAPE, TAPE 2)** 74 dB

50 mW de potencia (4Ω)  
**TOCADISC. (PHONO) MM** 68 dB  
**MC** 67 dB

**SINTON., DISCO COMPACTO, TV/AUX. 1, VIDEO/AUX. 2, GRAB. 1/DIGITAL, GRAB. 2 (TUNER, CD, TV/AUX 1, VIDEO/AUX 2, TAPE 1/DA TAPE, TAPE 2)** 69 dB

**Filtro subsónico** 30 Hz, -6 dB/oct.

**Control de sonoridad (volumen a -30 dB)** 50 Hz, +9 dB

**Voltaje e impedancia de salida**  
**SAL. GRAB. (REC OUT)** 150 mV

**Equilibrio de canales, CD, AUX 1, 2 250 Hz~6 300 Hz** ±1 dB

**Separación de canales, CD, AUX 1, 2 1 kHz** 55 dB

**Impedancia y nivel de salida de los auriculares** 670 mV/330Ω

**Impedancia de carga**

**MAIN o REMOTE** 4Ω~16Ω

**MAIN y REMOTE** 8Ω~16Ω

### GENERAL

**Consumo de energía** 580W

**Alimentación de energía** CA 50 Hz/60 Hz, 110V/120V/220V/240V

**Dimensiones (An.×Al.×Prof.)** 430 × 141,6 × 380 mm

**Peso** 11 kg

**Nota:**

La distorsión armónica total se mide con el analizador de espectro digital (sistema H.P. 3045).

(Estas especificaciones están sujetas a cualquier cambio sin previo aviso.)

## PROTECTION CIRCUITRY

The protection circuitry may have operated if either of the following conditions is noticed:

- No sound is heard when the power is turned on.
- Sound stops during performance.

The function of this circuitry is to prevent circuitry damage if, for example, the positive and negative speaker connection wires are "shorted", or if speaker systems with an impedance less than the indicated rated impedance of this unit are used.

If this occurs, follow the procedure outlined below:

1. Turn off the power.
2. Determine the cause of the problem and correct it.
3. Turn on the power once again after one minute.

#### Note

When the protection circuitry functions, the unit will not operate unless the power is first turned off and then on again.

## BEFORE REPAIR AND ADJUSTMENT

1. Turn off the power supply and short-circuit of power supply capacitors (C701 and C702, 15000μF) at resistance (about 10Ω, 5W) in order to discharge the charged voltage. Do not short between C701 and C702 by screwdriver. It may damage the component.
2. Before turning on the power supply after completion of repair, slowly apply the primary voltage by using a power supply voltage controller to make sure that the consumed current is free of abnormality. The consumed current at 60Hz/50Hz in no signal mode is shown below with respect to supply voltage 110V/120V/220V/240V.

Power supply voltage		AC110V	AC120V	AC220V	AC240V
Consumed current	50 Hz	390 ~ 675 mA	360 ~ 620 mA	200 ~ 340 mA	180 ~ 315 mA
	60 Hz	360 ~ 645 mA	330 ~ 600 mA	180 ~ 325 mA	165 ~ 300 mA

## LOCATION OF CONTROLS

### Change of Rear panel

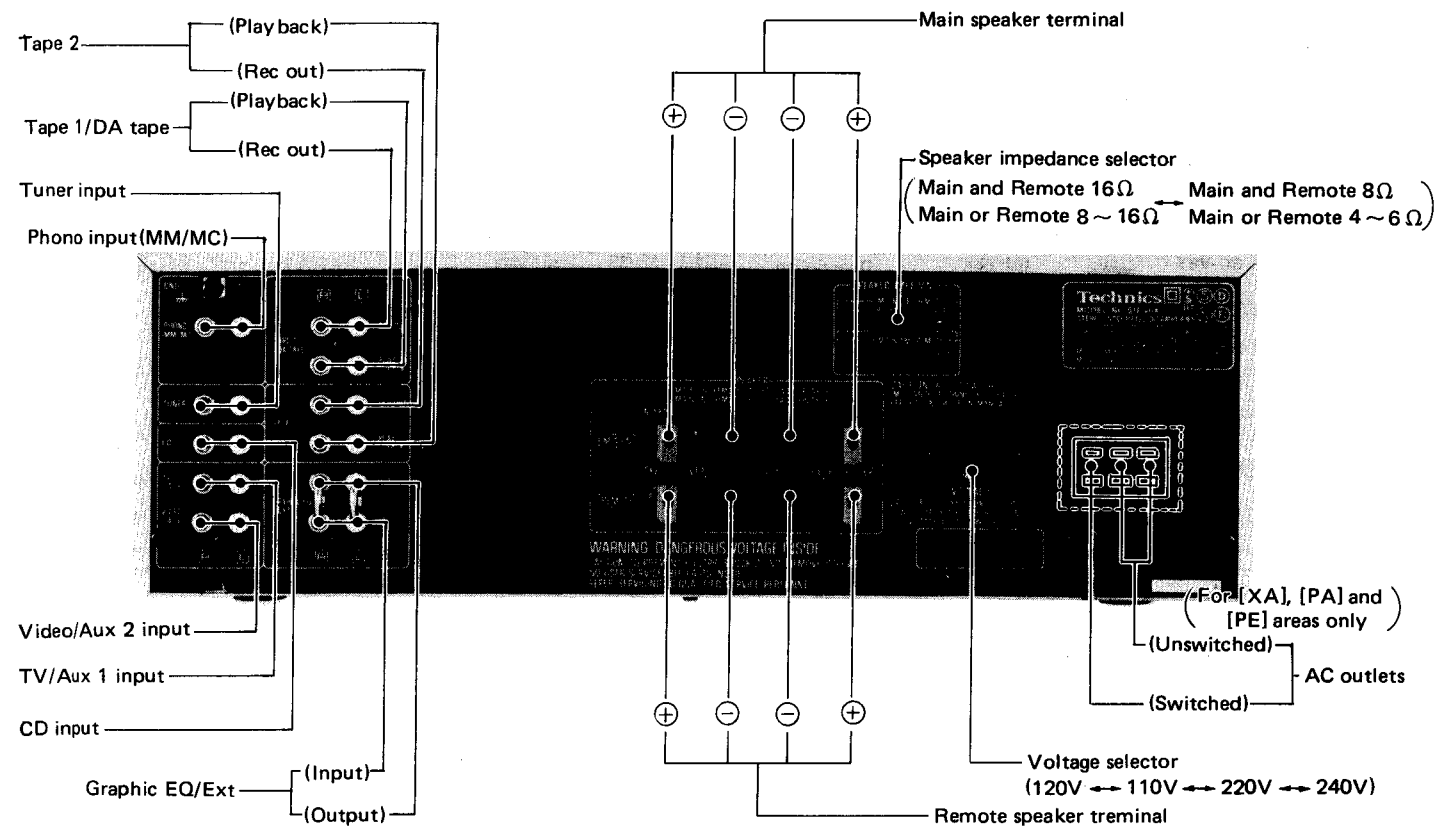

- The power supply for this unit varies depending upon the areas. Also, the parts used for power supply are different. So, refer to the circuit diagram and the replacement parts list.
- \* Phono input capacitance is about 150pF.

## MESSUNGEN UND JUSTIERUNGEN

- Einstellungen und zu verwendende Instrumente
1. AF-Oszillator.
  2. Wechselstrom und Gleichstrom Röhrevoltmeter.
  3. Frequenzzähler.
  4. Oszilloskop.

### 1. Leerlauf-Einstellung (ICQ) (nach Reparatur des integrierten Verstärkers)

1. Nach der Reparatur ist der Lautstärkeregel auf Maximum einzustellen, bevor der Netzschalter eingeschaltet wird, und an die Lautsprecher-Anschlußbuchsen ist nichts anzuschließen.
2. Die ICQ-Regler (VR301, VR302) entgegen dem Uhrzeigersinn drehen.
3. Die an den Verstärker angelegte Spannung allmählich mit dem Spannungsregler erhöhen und vor Beginn der Justierung ist der Wert in der nachstehenden Tabelle zu überprüfen.
4. Das elektronische Gleichstrom-Voltmeter an TP302 (+) und TP301 (-) (L Kanal), oder TP304 (+) und TP303 (-) (R Kanal) anschließen.
5. VR301 (L. Kanal) und VR 302 (R. Kanal) so justieren, daß die Spannung ca. 15~20 Minuten nach Einschalten des Netzschalters 20mV beträgt.

\* In diesem Gerät wird ICQ durch einen Mikrocomputer geregelt, und ICQ von etwas mehr als dem normalen Pegel wird durch "PREHEAT" während ca. 14 ~ 16 Sekunden nach Einschalten der Stromzufuhr zugeführt. Danach werden der Ausgangspegel und die Transistortemperatur durch "AUTO" erfaßt, wodurch ICQ automatisch geregelt wird.

### 2. Prüfung der Stummschaltung bei ausgeschalteter Stromzufuhr

1. Wechselstrom-Voltmeter und 8Ω-Last (Widerstand oder Lautsprecher) an die Hauptlautsprecherausgänge anschließen.
2. Den Lautstärkeregel auf einen zweckmäßigen Lautstärkepegel einstellen.
3. Ein 1kHz-Signal, 100mV, in den AUX-Eingangsanschluß eingeben.
4. Überprüfen, daß die Ausgangsleistung 3 ~ 5 Sekunden nach Einschalten des Netzschalters auf "on" vorhanden ist, und daß die Ausgangsleistung sofort nach Ausschalten des Netzschalters auf "off" verfällt.

### 3. Prüfung der Überlasterschutts- und -Schutzschaltung

1. Den Lautstärkeregel auf Maximum einstellen.
2. Den AF-Oszillator an den AUX-Anschluß anschließen und ein 1kHz-Signal eingeben. Dann den Ausgangspegel des AF-Oszillators so einstellen, daß der Ausgangspegel an den Lautsprecheranschlüssen 1,5V beträgt.

3. Bei kurzgeschlossenen (L. Kanal) Hauptlautsprecheranschlüssen (mit Leitungsdraht, der so kurz und dick wie möglich sein sollte):

Überprüfen daß:

- das Relais ausgeschaltet ist.
- die "auto"-Anzeige "on" erlischt.
- die "safety operation"-Anzeige blinkt.

4. Wenn das Relais ausgeschaltet ist, Netzschalter auf "off" stellen und eine Weile warten, bevor er wieder auf "on" gestellt wird. Andernfalls werden die ursprünglichen Zustände auch dann nicht wiederhergestellt, wenn Schaltung und Last wieder normal sind.

### 4. Prüfung der Detektions-Schaltung

1. Den Eingangs-Wahlschalter in die "tuner"-Position stellen.
2. +1V Gleichspannung (an L. Kanal) an den Wiedergabe-Anschluß von "tape 1"; und -1V (an R. Kanal) an den Wiedergabe-Anschluß von "tape 2" anlegen.
3. Den Eingangs-Wahlschalter in die "tape 1"-Position stellen.

Überprüfen daß:

- das Relais ausgeschaltet ist.
- die "auto"-Anzeige "on" erlischt.
- die "safety operation"-Anzeige blinkt.

## MESURAGES ET RÉGLAGES

### • Réglages et appareils utilisés

1. Oscillateur de fréquences audios.
2. Voltmètre électronique à CA et à CC.
3. Compteur de fréquences.
4. Oszilloscope.

### 1. Réglage de la marche à vide (ICQ) (après réparation de l'amplif. principal).

1. La réparation une fois achevée, régler le volume sonore au maximum avant de mettre en circuit le commutateur d'alimentation, et ne rien raccorder aux bornes des haut-parleurs.
2. Tourner complètement la commande ICQ (VR301, VR302) dans le sens inverse des aiguilles d'une montre.
3. Augmenter graduellement la tension appliquée à l'amplificateur à partir de OV au moyen du régulateur de tension, et vérifier la valeur d'après le tableau ci-dessous avant de commencer l'ajustement.
4. Raccorder le voltmètre électronique à C. C. à TP302 (+) et à TP301 (-) (canal de gauche) ou à TP304 (+) et à TP303 (-) (canal de droite).
5. Régler VR301 (Canal de gauche) ou VR302 (Canal de droite) de telle sorte que la tension soit de 20mV à peu près 15 ~ 20 minutes après que l'interrupteur d'alimentation est mis "en circuit" ("on").

\* Dans cet appareil, ICQ est contrôlé par un microordinateur, et ICQ un peu plus que le niveau normal est appliqué par "PRECHAUFFAGE" pendant à peu près 14 ~ 16 secondes après la mise sous tension. Après cela, le niveau de sortie et la température du transistor sont détectés à par AUTO contrôlant automatiquement ICQ.

### 2. Vérification de l'accord silencieux avec la mise sous tension/hors circuit.

1. Raccorder un voltmètre à C.A. et une charge de 8Ω (résistance ou haut-parleur) aux bornes du haut-parleur principal.
2. Régler l'intensité sonore sur un niveau approprié.
3. Appliquer un signal de 1kHz 100mV à la borne d'entrée AUXILIAIRE.
4. S'assurer que la puissance de sortie soit amplifiée 3 ~ 5 secondes après la "mise sous tension" de l'interrupteur d'alimentation et que la puissance de sortie s'éteigne immédiatement après la "mise hors circuit" de l'interrupteur d'alimentation.

### 3. Vérification de la détection d'une surcharge et du circuit de protection.

1. Régler la commande du volume au maximum.
2. Raccorder l'oscillateur d'audio-fréquences à la borne AUXILIAIRE et appliquer un signal d'entrée de 1kHz à la borne. Puis, régler le niveau de sortie de l'oscillateur d'audio-fréquences de telle sorte que le niveau de sortie des bornes du haut-parleur soit de 1,5V.
3. Avec les bornes du haut-parleur principal (Canal de gauche) court-circuitées par un fil d'amenée (aussi épais et court que possible):

S'assurer que:

- le relais est hors circuit.
- l'indicateur "auto" qui est "en circuit" s'éteint.
- l'indicateur de "sécurité de fonctionnement" clignote.

4. Lorsque le relais est hors circuit, mettre "hors circuit" l'alimentation et l'appareil pendant un certain temps avant de le mettre "en marche". Autrement, les conditions initiales ne seront pas rétablies, même lorsque le circuit et la charge sont normaux.

### 4. Vérification du circuit de détection par C. C.

1. Régler le sélecteur d'entrée sur la position "tuner".
2. Appliquer une tension C. C. de +1V (au canal de gauche) à la borne de lecture de la bande 1 et de -1V (au canal de droite) à la borne de lecture de la bande 2.
3. Régler le sélecteur d'entrée sur la position "tape 1".

S'assurer que:

- le relais est hors circuit.
- l'indicateur "auto" qui est "en circuit" s'éteint.
- l'indicateur de "sécurité de fonctionnement" clignote.

## MEDICIONES Y AJUSTE

● Puesta e instrumentos usados

- Oscilador AF
- Voltmetro electrónico de CA y CC.
- Contador de frecuencia.
- Osciloscopia.

### 1. Ajuste de Marcha Lenta (ICQ) (después de reparar el amp. principal)

- Después de la reparación, ajustar el volumen de sonido a máximo antes de prender el interruptor de alimentación, y no conectar nada a los terminales de altavoz.
- Girar completamente a la derecha el contador de control ICQ (VR301, VR302).
- Aumente el voltaje aplicado al amplificador gradualmente desde 0V mediante un regulador de voltaje, y asegúrese del valor en la tabla de abajo antes de comenzar el ajuste.
- Conectar el voltímetro electrónico CC a TP302 (+) y TP301 (-) (Canal I) o TP304 (+) y TP303 (-) (Canal D).
- Ajuste VR301 (canal I) o VR302 (canal D) de manera que el voltaje sea 20mV unos 15 ~ 20 min. después de conectar la corriente.

\* En este aparato, ICQ es regulado mediante un microcomputador, y ICQ, un poco más del nivel normal, es aplicado mediante "PRECALENTAMIENTO" por unos 14~16 seg. después de conectar la corriente. Después de eso, el nivel de salida y la temperatura de transistor son detectados mediante AUTO allí automáticamente regulando ICQ.

### 2. Comprobación de silenciamiento con corriente conectada/desconectada.

- Conecte voltímetro de CA y carga de 8Ω (resistor o altavoz) a terminales de altavoz principales.
- Ajuste el volumen de sonido a un nivel apropiado.
- Aplique señal de 1kHz 100mV a terminal de entrada AUX.
- Asegúrese de que salida sea ganada 3 ~ 5seg. después de conectar la corriente y que la salida desaparezca inmediatamente después de desconectar la corriente.

### 3. Comprobación de detección de sobrecarga y circuito de protección

- Ponga el control de volumen en máximo.
- Conecte el oscilador AF al terminal AUX y aplique la señal de entrada de 1kHz al terminal. Luego ajuste el nivel de salida del oscilador AF de manera que el nivel de salida de los terminales de altavoz se convierta en 1,5V.
- Con los terminales de altavoz (canal I) cortocircuitados mediante hilo conductor (lo más grueso y corto posible):

Asegurar de que:   
 — relé está desconectado.   
 — indicador "auto" "on" (encendido) se apaga.   
 — indicador de operación de seguridad parpadea.

- Cuando el relé esté desconectado, desconecte la corriente y unidad por un rato antes de conectarla. De lo contrario, las condiciones originales no se restaurarán aun cuando el circuito y la carga sean normales.

### 4. Comprobación de Circuito de Detección CC

- Poner el selector de entrada en la posición de "sintonizador".
- Aplique Voltaje CC +1V (Canal I) al terminal de reproducción de cinta 1, -1V (Canal D) al terminal de reproducción de cinta 2.
- Poner el selector de entrada en la posición de "cinta 1".

Asegurar de que   
 — relé está desconectado.   
 — indicador "auto" "on" (encendido) se apaga.   
 — indicador de operación de seguridad parpadea.

## CHANGES

## REPLACEMENT PARTS LIST

- Notes: 1. Part numbers are indicated on most mechanical parts. Please use this part number for parts order.  
 2. Important safety notice: Components identified by Δ mark have special characteristics important for safety. When replacing any of these components, use only manufacturer's specified parts.  
 3. ⊗ —marked parts are used for black only, while ○ —marked parts are for silver type only.  
 4. Part other than ⊗ — and ○ —marked are used for both black and silver type.  
 5. Bracketed indications in Ref. No. columns specify the area. Parts without these indications can be used for all areas.  
 6. The "S" mark is service standard parts and may differ from production parts.  
 7. The parenthesized numbers in the column of description stand for the quantity per set.

Ref. No.	Change of Part No.		Part Name & Description	Per Set (Pcs.)	Ref. No.	Change of Part No.		Part Name & Description	Per Set (Pcs.)
	SU-V6X [M]	SU-V6X [D,EF,EH,EW,EK,XA,XL,PA,PE]				SU-V6X [M]	SU-V6X [D,EF,EH,EW,EK,XA,XL,PA,PE]		
<b>TRANSISTORS</b>					<b>CABINET &amp; CHASSIS PARTS</b>				
Q309,310	2SA1123-R	2SA1124-R	Inverter	2	11	SBC641-4G	○ SBC641-2G ⊗ SBC641-4G	Button, Tape 2	1
<b>DIODES</b>					12	SBC641-4H	○ SBC641-2H ⊗ SBC641-4G	Button, Tape 1	1
D403-406	MA182	Deletion	(Correction)	0	14	SBC643-2	○ SBC643 ⊗ SBC643-2	Button, Muting	1
D618	LN0603YP4	LN0603GP3G [PA,PE] LN0603YP4 [Other]	LED	1	19	SJT345	SJT347	Crip, Fuse	2
<b>TRANSFORMER</b>					<b>PACKING PARTS</b>				
T1	SLT5Q139	SLT5Q135	Power Source Δ	1	28	SGPUV6X-KM	SGPUV6X-SK [EK] SGPUV6X-SL [XL] SGPUV6X-SX [XA] SGPUV6X-SD [Other]	Rear Panel Ass'y	1
<b>FUSES</b>					29	RJA9Y	SJA111 [EW,XA] QFC1205M [EK] QFC1207MA [XL] RJA52YA [PA,PE] SJA97 [Other]	AC Cord Δ	1
F1	XBA1F60NU14	XBA2C63TR0	250V, T6.3A Δ	1	30	SJS601-3	SJS601-3 [XA,PA,PE] Deletion [Other]	Socket Δ	1
F2	Addition	XBA2C31TR0	250V, T3.15A Δ	1	31	SKC1590BB2	○ SKC1590S2 ⊗ SKC1590BB2	Cabinet	1
<b>SWITCHES</b>					35	RHR111	SHR129 [EK] SHR131 [XL] SHR127 [Other]	Bushing	1
S11	ESB70221T	SSH1158	Impedance Selector Δ	1	<b>ACCESSORIES</b>				
S12	SSH1109	ESB90259S	Power Source Δ	1	A1	SQF12050	SQF12054 [XA] SQF12055 [PA,PE] SQF12052 [Other]	Instruction Book	1
S13	Addition	ESE37219	Voltage Selector Δ	1	A2	Addition	SJP9215 [PA,PE] SJP5213-1 [XA] SJP5215 [XA]	Plug Δ	1
<b>RESISTORS</b>					<b>REPAIR PARTS</b>				
R331,332	ERD25FJ102	ERD2FCG102	Carbon, 1kΩ	2	1	SGWUV6X-KM	○ SGWUV6X-SP [PA,PE] ○ SGWUV6X-SD [Other] ⊗ SGWUV6X-KD	Front Panel Ass'y	1
R333,334	ERD25FJ102	ERD2FCG102	Carbon, 1kΩ	2	5	SBC641-4A	○ SBC641-2A ⊗ SBC641-4A	Button, Phono	1
R339,340	ERD25FJ102	ERD2FCG102	Carbon, 1kΩ	2	6	SBC641-4B	○ SBC641-2B ⊗ SBC641-4B	Button, Tuner	1
R341,342	ERD25FJ102	ERD2FCG102	Carbon, 1kΩ	2	7	SBC641-4C	○ SBC641-2C ⊗ SBC641-4C	Button, CD	1
R375,376	ERD25FJ331	ERD2FCG331	Carbon, 330	2	8	SBC641-4D	○ SBC641-2D ⊗ SBC641-4D	Button, Video/AUX2	1
R387,388	ERD25FJ-100	ERD2FCG100	Carbon, 10Ω	2	9	SBC641-4E	○ SBC641-2E ⊗ SBC641-4E	Button, TV/AUX1	1
R701,702	ERG1ANJ391	ERQ12AJ391	Fuse Type Metal, 390Ω	2	10	SBC641-4F	○ SBC641-2F ⊗ SBC641-4F	Button, Source	1
<b>CAPACITORS</b>					<b>REPAIR PARTS</b>				
C331,332	ECKD1H223ZF	ECKD1H473ZF	Ceramic, 0.047μF	2	P1	SPG4820	SPG4819 [EF] SPG4820 [EW,XA,PA,PE] SPG4818 [Other] ○ SPG4837 [EK] ⊗ SPG4837-1 [EK]	Carton Box	1
C335,336	Addition	ECKD1H473ZF	Ceramic, 0.047μF	2	P2	SPS4289-4	SPS4289-4 [EW,EK,XA,PA,PE] SPS-4289-5 [Other]	Pad, Left Side	1
C701,702	ECET71V153Z	ECET71V153X	Electrolytic, 15,000μF	2	P3	SPS4291-4	SPS4291-4 [EW,EK,XA,PA,PE] SPS4291-5 [Other]	Pad, Right Side	1
<b>CABINET &amp; CHASSIS PARTS</b>					<b>REPAIR PARTS</b>				

■ SCHEMATIC DIAGRAM

● Change of power supply

For [M] area

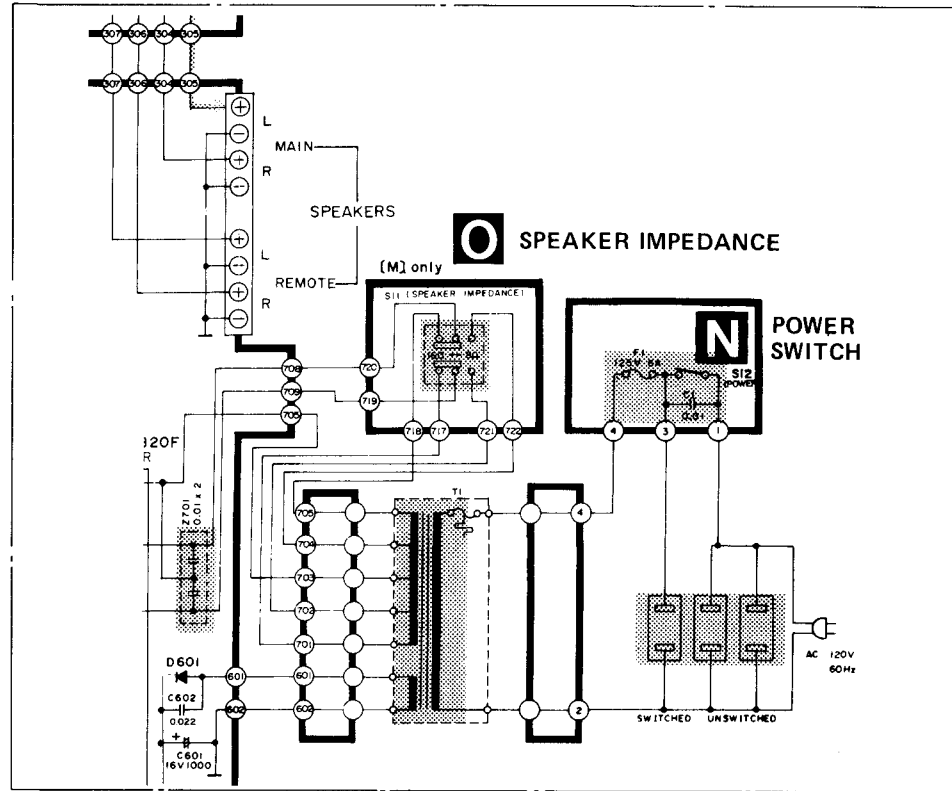

For [XA], [PA] and [PE] areas

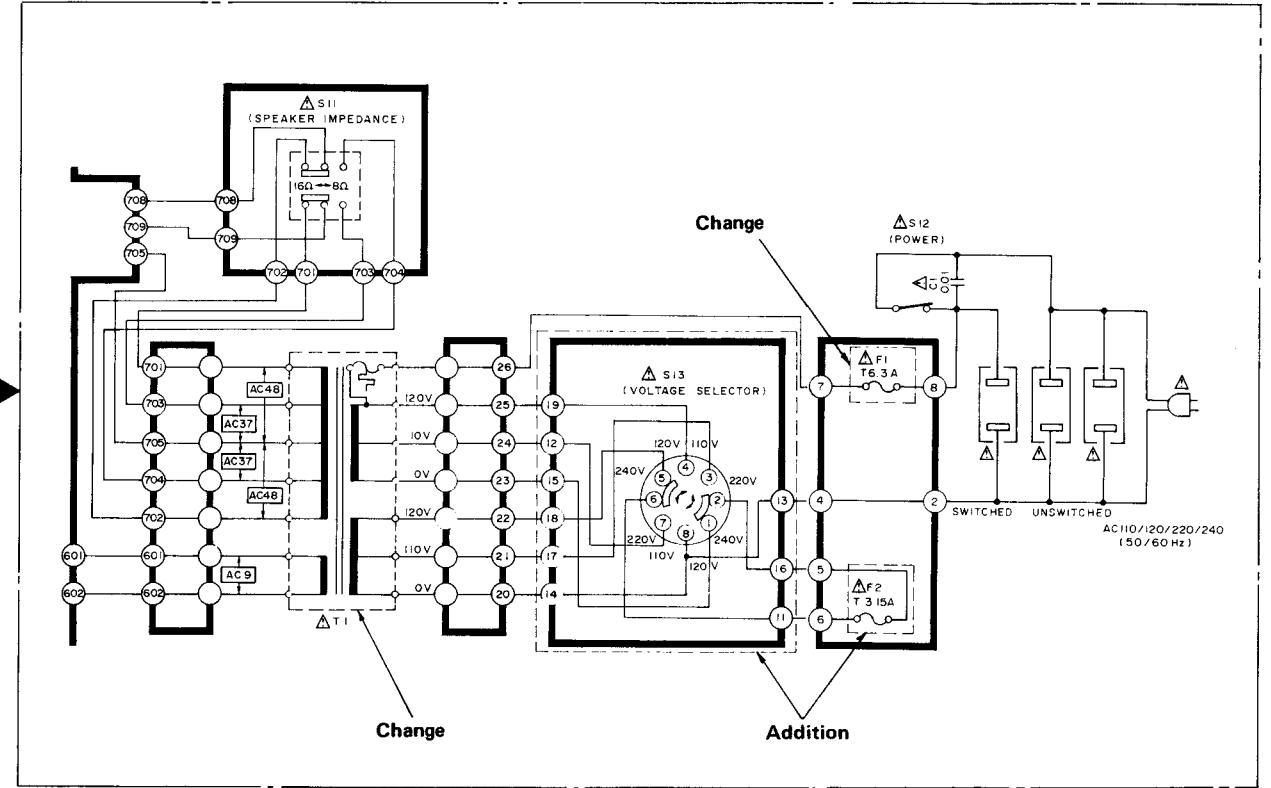

For Continental Europe ([D], [EH], [EB], [EW], [Ei], [EK], [EF] areas)

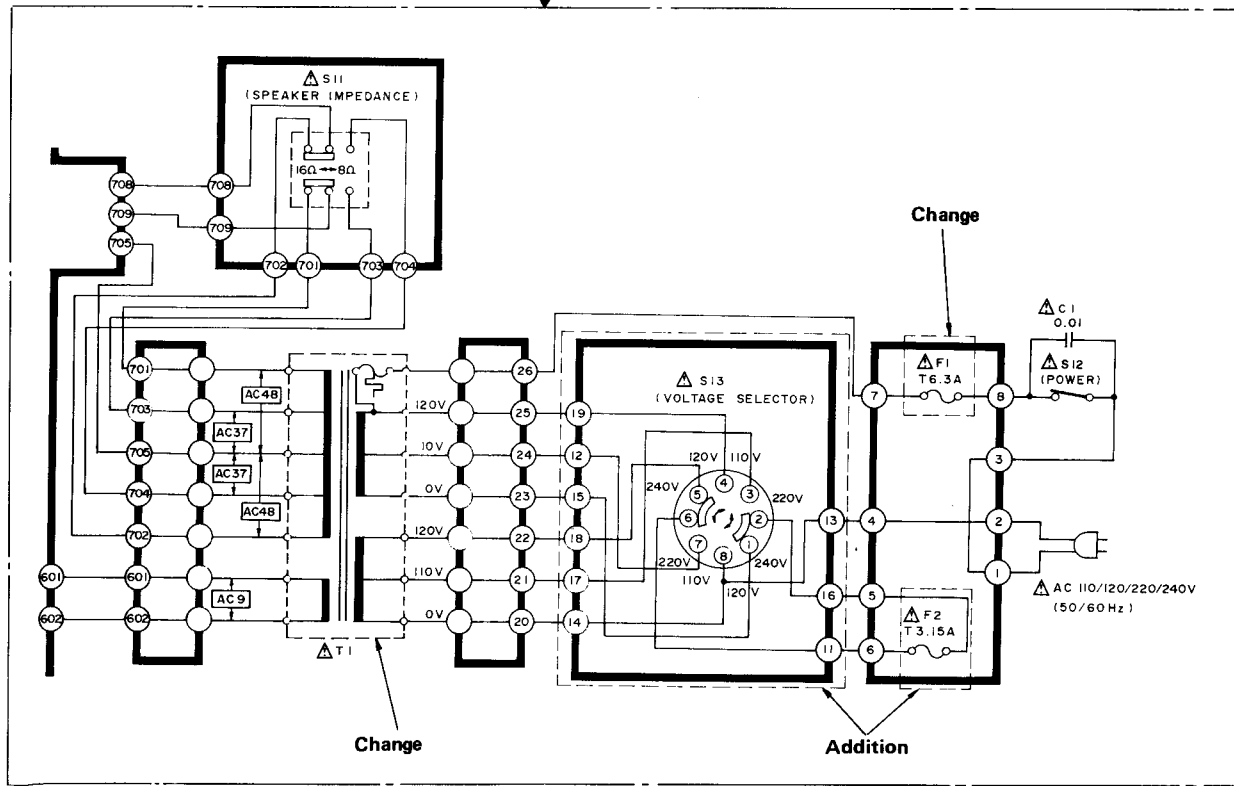

For [XL] area

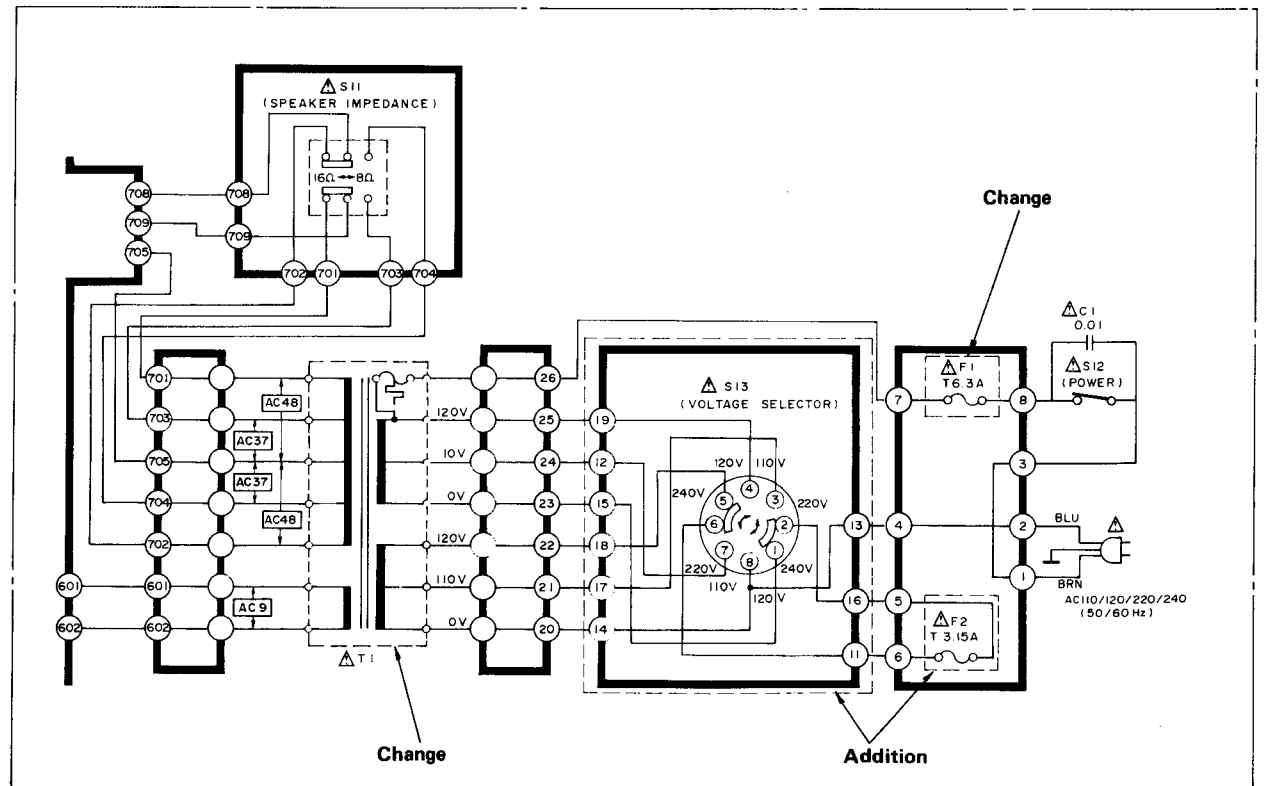

## REPLACEMENT PARTS LIST

- Notes:**
- Part numbers are indicated on most mechanical parts. Please use this part number for parts order.
  - Important safety notice: Components identified by  $\Delta$  mark have special characteristics important for safety. When replacing any of these components, use only manufacturer's specified parts.
  - $\otimes$  -marked parts are used for black only, while  $\circ$  -marked parts are for silver type only.
  - Part other than  $\otimes$  - and  $\circ$  -marked are used for both black and silver type.
  - Bracketed indications in Ref. No. columns specify the area. Parts without these indications can be used for all areas.
  - The "S" mark is service standard parts and may differ from production parts.
  - The parenthesized numbers in the column of description stand for the quantity per set.

Ref. No.	Part No.	Part Name & Description
<b>INTEGRATED CIRCUITS</b>		
IC21	MN1404STE	ICQ Control
IC101	SVINJM4560DX	Equalizer AMP
<b>TRANSISTORS</b>		
Q21~29	2SC1815-Y	Switching
Q101~104	2SK369-GR	FET Differential AMP
(Use pair ranks as same as Q101, Q102, Q103 and Q104)		
Q301, 302	2SK389-GR	FET Differential AMP
Q305~308	2SC1845-E	FET Differential AMP Over Load Deft, Relay Drive.
Q309, 310	2SA1124-R	Inverter
Q311, 312	2SA1124-R	A Class AMP
Q313, 314	2SC2632-R	A Class AMP
Q315, 316	2SC2631-Q	Pre Drive
Q317, 318	2SA1123-S	Pre Drive
(Use pair ranks as same as Q315, Q316, Q317 and Q318)		
Q319, 320	2SC2592-R	Drive
Q321, 322	2SA1112-R	Drive
(Use pair ranks as same as Q319, Q320, S321 and Q322)		
Q323, 324	2SC3280-R	Power AMP
Q325, 326	2SA1301-R	Power AMP
(Use pair ranks as same as Q323, Q324, Q325 and Q326)		
Q327, 328	2SD661-S	Bias Control
Q329, 330, 705	2SC1815-Y	Bias Control, Regulator
Q701	2SC2592-R	Regulator
Q702	2SA1112-R	Regulator
Q703, 704	2SK34-D1	Regulator
<b>DIODES</b>		
D21, 22	MA162A	Switching
D23	MA1062A	6. 2V Zener
D101, 102	MA162A	Switching
305~310, 506		
D311~314	MA182	Switching
D315, 316	MA27W-A	Switching
325~328		
D317~324	0A90	Switching
D501~505	MA162A	Signal Rectifier
D601	SVDSR1K2	Rectifier
D605, 608	LN446YP	Power, Via Tone IND
D606	LN346GP	Auto IND
D607	LN846RP	Straight DC IND
D609~613, 615	SVDP5533K	Input Selector IND
D614, 616, 617	SVDA5533K-M	Tape Selector IND
D618(PA, PE)	LN0603GP3G	LED
D618(other)	LN0603YP4	New Class A IND
D623~626	MA1030	3V Zener
D701	SVDS10VB20F	Rectifier
D702	SVDMZ322A	22V Zener
<b>COILS and TRANSFORMER</b>		
L301, 302	SLQY15G-30	Choke
T1	SLT5Q135	Power Source
<b>VARIABLE RESISTORS</b>		
VR201	EWJKMA054B15	Volume Adj, 100k $\Omega$ (B)
VR202	EWHFKA002G15	Volume Balance Adj, 100k $\Omega$ (G)
VR203	EWCX8A011012	Tone Adj
VR204	EWXEA011C15	Bass Adj
VR301, 302	EVNK6AA00B13	ICQ Adj, 1k $\Omega$ (B)

Ref. No.	Part No.	Part Name & Description
<b>FUSE</b>		
F1	$\Delta$ XBA2C63TR0	250V, T6. 3A
F2	$\Delta$ XBA2C31TR0	250V, T3. 15A
<b>COMPONENT COMBINATIONS</b>		
Z301, 302	$\Delta$ ERF3GBKR22N	3W, 0.22 $\Omega$ ( $\times$ 2)
Z701	$\Delta$ SXRFS203ZSM	0.01 $\mu$ F( $\times$ 2)
<b>THERMISTERS</b>		
TH301, 302	ERTD2ZHL103S	10k $\Omega$
PS601	SRPBG47101	Temperature Det (60°C, 140°F)
<b>SWITCHES</b>		
S1, 6, 7	SSH3065	Phono Selector, Loudness, Subsonic Filter
S2, 3	SSH807	Input Selector, Tape Monitor
S4	SSR189	Rec Output Selector
S5	SSH1143	Audio Muting
S8	SSH1141	Terperation
S9, 10	SSH2017	Speaker Selector
S11	SSH1158	Speaker Impedance Selector
S12	$\Delta$ ESB90259S	Power Source
S13	$\Delta$ ESE37219	Voltage Selector
<b>RELAY</b>		
RLY501	$\Delta$ SSY105	Speaker Protection
<b>CABINET and CHASSIS PAPTS</b>		
1(PA, PE)	$\circ$ SGWUV6X-SP	Front Panel Ass'y (1)
1(other)	$\circ$ SGWUV6X-SD	Front Panel Ass'y (1)
1	$\otimes$ SGWUV6X-KD	Front Panel Ass'y (1)
2	SBN993-1	Knob, Bass, Treble, Rec (3)
3	SBN1181	Knob, Balance (1)
4	SBN1177	Knob, Volume (1)
5	$\circ$ SBC641-2A	Button, Phono (1)
5	$\otimes$ SBC641-4A	Button, Phono (1)
6	$\circ$ SBC641-2B	Button, Tuner (1)
6	$\otimes$ SBC641-4B	Button, Tuner (1)
7	$\circ$ SBC641-2C	Button, CD (1)
7	$\otimes$ SBC641-4C	Button, CD (1)
8	$\circ$ SBC641-2D	Button, Video/AUX2 (1)
8	$\otimes$ SBC641-4D	Button, Video/AUX2 (1)
9	$\circ$ SBC641-2E	Button, TV/AUX1 (1)
9	$\otimes$ SBC641-4E	Button, TV/AUX1 (1)
10	$\circ$ SBC641-2F	Button, Source (1)
10	$\otimes$ SBC641-4F	Button, Source (1)
11	$\circ$ SBC641-2G	Button, Tape 2 (1)
11	$\otimes$ SBC641-4G	Button, Tape 2 (1)
12	$\circ$ SBC641-2H	Button, Tape 1 (1)
12	$\otimes$ SBC641-4H	Button, Tape 1 (1)

Ref. No.	Part No.	Part Name & Description
<b>CABINET and CHASSIS PAPT</b>		
13	SUS753-1	Spring, Input Selector (8)
14	SBC643	Button, Muting (1)
15	SUS123-3	Spring, Muting (1)
16	SBC399T	Button, Speaker, Operation (3)
17	SBC627	Button, Power (1)
18	SBC621	Button, Subsonic Filter, Loudness, Phono (3)
19	SJT347	Crip, Fuse (4)
20	SJJ71B	Jack, Headphone(1)
21	SML107-7	Plate, Power Transformer (1)
22	SKU8990-4	Bottom Board (1)
23	SKL249	Foot (4)
24	SMN1893	Fix Plate (1)
25	SJF4815-1	Permal Board, Speaker (1)
26	SJF3059-8N	Terminal Board, Tape 1, Tape 2 (1)
27	SJF3059-2N	Terminal Board, Source input (1)
28(EK)	SGPUV6X-SK	Rear Panel Ass'y (1)
28(XL)	SGPUV6X-SL	Rear Panel Ass'y (1)
28(XA)	SGPUV6X-SX	Rear Panel Ass'y (1)
28(other)	SGPUV6X-SD	Rear Panel Ass'y (1)
29(EW)	$\Delta$ SJA111	AC Cord (1)
29(EK)	$\Delta$ QFC1205M	AC Cord (1)
29(XL)	$\Delta$ QFC1207MA	AC Cord (1)
29(PA, PE)	$\Delta$ RJA52YA	AC Cord (1)
29(other)	$\Delta$ SJA97	AC Cord (1)
30(XA, PA, PE) only	$\Delta$ SJS601-3	Socket (1)
31	$\circ$ SKC1590S2	Cobinet (1)
31	$\otimes$ SKC1590BB2	Cabinet (1)
32	SHR9717	Holder, P. C. B. (1)
33	SHR9720	Holder, P. C. B. (1)
34	SJP9205-2	Pin (2)
35(XL)	SHR131	Bushing (1)
35(EK)	SHR129	Bushing (1)
35(other)	SHR127	Bushing (1)
36	SUW2827-1	Plaep, Speaker Switch (1)
37	SBC527	Button, Impedance Selector (1)
38	SJT3319	Post(3 pin) (1)
38	SJT3213	Post(2 pin) (1)
39	SJS5331	Socket(3 pin) (1)
39	SJS5629	Socket(6 pin) (1)
40	SJT783	Terminal (1)
<b>SCREWS, WASHERS and NUT</b>		
N1	$\otimes$ XT3+8FZ	Tapping, $\otimes$ 3 $\times$ 8 (4)
N2	$\otimes$ XT3+8BFZ	Tapping, $\otimes$ 3 $\times$ 8 (4)
N3	$\otimes$ XSN3+6S	Tapping, $\otimes$ 3 $\times$ 6 (2)
N4	$\otimes$ XWA3B	Spring, $\phi$ 3 (2)
N5	$\otimes$ XSN3+6S	$\otimes$ 3 $\times$ 6 (2)
N6	$\otimes$ XWA3B	Spring, $\phi$ 3 (2)

Ref. No.	Part No.	Part Name & Description
<b>SCREWS, WASHERS and NUT</b>		
N7	$\otimes$ XSN3+6S	$\otimes$ 3 $\times$ 6 (3)
N8	$\otimes$ XWA3B	Spring, $\phi$ 3 (3)
N9	$\otimes$ XSN3+6S	$\otimes$ 3 $\times$ 6 (3)
N10	$\otimes$ XWA3B	Spring, $\phi$ 3 (3)
N11	SNE4021	Nut (2)
N12	SNE4021	Nut (1)
N13	SNE4021	Nut (1)
N14	$\otimes$ XT3+8BFZ	Tapping, $\otimes$ 3 $\times$ 8 (4)
N15	$\otimes$ XT3+10BFN	Tapping, $\otimes$ 3 $\times$ 10(4)
N16	$\otimes$ XWG3	Thin, $\phi$ 3 (4)
N17	XTB4+10BFN	Tapping, $\otimes$ 4 $\times$ 10(4)
N18	$\otimes$ XT3+6BFZ	Tapping, $\otimes$ 3 $\times$ 6 (5)
N19	$\otimes$ XT3+6BFZ	Tapping, $\otimes$ 3 $\times$ 6 (1)
N20	$\otimes$ XT3+8BFZ	Tapping, $\otimes$ 3 $\times$ 8 (3)
N21	$\otimes$ XT3+8BFZ	Tapping, $\otimes$ 3 $\times$ 8 (2)
N22	$\otimes$ XT3+8BFZ	Tapping, $\otimes$ 3 $\times$ 8 (4)
N23	$\circ$ SEN2095-4	Cabinet (6)
N23	$\otimes$ SNE2095-5	Cabinet (6)
N24	$\otimes$ XSN3+6FZS	SP SW, $\otimes$ 3 $\times$ 6 (2)
<b>PACKING PARTS</b>		
P1(EK)	$\circ$ SPG4837	Carton Box (1)
P1(EK)	$\otimes$ SPG4837-1	Carton Box (1)
P1(EF)	SPG4819	Carton Box (1)
P1(EW, XA, PA, PE)	SPG4820	Carton Box (1)
P1(other)	SPG4818	Carton Box (1)
P2(EW, EK, XA, PA, PE)	SPS4289-4	Pad, Left Side (1)
P2(other)	SPS4289-5	Pad, Left Side (1)
P3(EW, EK, XA, PA, PE)	SPS4291-4	Pad, Right Side (1)
P3(other)	SPS4291-5	Pad, Right Side (1)
P4	SPP730	Polyethylene Bag (1)
<b>ACCESSORIES</b>		
A1(XA)	SQF12054	Instruction Book(1)
A1(PA, PE)	SQF12055	Instruction Book(1)
A1(other)	SQF12052	Instruction Book(1)
A2(PA, PE)	$\Delta$ SJP9215	Plug
A2(XA)	$\Delta$ SJP5213-1	Plug
A2(XA)	$\Delta$ SJP5215	Plug



# Service Manual

Stereo Integrated DC Amplifier  
**SU-V6X(K)**  
 [M], [MC]

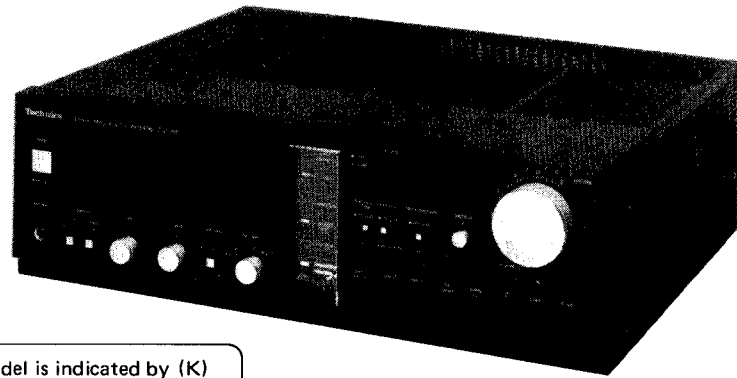

\* The black type model is indicated by (K) in the Service Manual.  
 \* The colors of this model is black type only.

**Areas**

\* [M] is available in the U.S.A.  
 \* [MC] is available in Canada.

## Specifications

(Specifications are subject to change without notice for further improvement.)  
 (Weights and dimensions shown are approximate.)

(IHF '78)

### AMPLIFIER SECTION

**Rated minimum sine wave RMS power output**  
 20 Hz~20 kHz both channels driven  
 0.003% total harmonic distortion  
 100W per channel (8 ohms)

20 Hz~20 kHz both channels driven  
 0.007% total harmonic distortion  
 100W per channel (4 ohms)

1 kHz continuous power output  
 both channels driven  
 0.001% total harmonic distortion  
 100W per channel (8 ohms)

0.0015% total harmonic distortion  
 100W per channel (4 ohms)

**Total harmonic distortion**  
 rated power at 20 Hz~20 kHz 0.003% (8 ohms)  
 half power at 20 Hz~20 kHz 0.002% (8 ohms)  
 half power at 1 kHz 0.001% (8 ohms)

**SMPTE intermodulation distortion** 0.007% (8 ohms)

**Frequency response**  
 PHONO RIAA standard curve  $\pm 0.5$  dB  
 TUNER, CD, TV/AUX 1, VIDEO/AUX 2,  
 TAPE 1/DA TAPE, TAPE 2 0.7 Hz~140 kHz, -3 dB  
 20 Hz~20 kHz, +0 dB, -0.2 dB

**Input sensitivity**  
 PHONO MM 0.25 mV (2.5 mV, IHF '66)  
 MC 17  $\mu$ V (170  $\mu$ V, IHF '66)  
 TUNER, CD, TV/AUX 1, VIDEO/AUX 2,  
 TAPE 1/DA TAPE, TAPE 2 15 mV (150 mV, IHF '66)

**S/N (IHF, A)**  
 PHONO MM 77 dB (88 dB, IHF '66 2.5mV input)  
 MC 77 dB (72 dB, IHF '66 250 $\mu$ V input)  
 TUNER, CD, TV/AUX 1, VIDEO/AUX 2,  
 TAPE 1/DA TAPE, TAPE 2 82 dB (104 dB, IHF '66)

### Maximum input voltage

PHONO MM	170 mV (210 mV, 1 kHz)
MC	12 mV (15 mV, 1 kHz)
<b>Input impedance</b>	
PHONO MM	47 kilohms
MC	220 ohms
TUNER, CD, TV/AUX 1, VIDEO/AUX 2, TAPE 1/DA TAPE, TAPE 2	18 kilohms
<b>Tone controls</b>	
BASS	50 Hz, +10 dB~ -10 dB
TREBLE	20 kHz, +10 dB~ -10 dB
Subsonic filter	30 Hz, -6 dB/oct.
Loudness control (volume at -30 dB)	50 Hz, +9 dB
Muting	-20 dB
<b>Output voltage</b>	
TAPE 1, 2 REC OUT	150 mV
<b>Low frequency damping factor</b>	
	80 (8 ohms)
	40 (4 ohms)
<b>Load impedance</b>	
MAIN or REMOTE	4~16 ohms
MAIN and REMOTE	8~16 ohms

### GENERAL

<b>Power consumption</b>	420W, 520 VA
<b>Power supply</b>	AC 120V, 60 Hz
<b>Dimensions (W×H×D)</b>	430 × 142 × 380 mm (16-15/16" × 5-9/16" × 14-15/16")
<b>Weight</b>	11 kg (24.2 lb.)

**Note:**

Total harmonic distortion is measured by the digital spectrum analyzer (H.P. 3045 system).

## SU-V6X

### CONTENTS

	Page		Page
SAFETY PRECAUTION	2	BLOCK DIAGRAM	13,14
LOCATION OF CONTROLS	3	FUNCTION OF TERMINAL	
PROTECTION CIRCUITRY	4	(IC <sub>CO</sub> CONTROLLER IC21)	15
BEFORE REPAIR AND ADJUSTMENT	4	SCHEMATIC DIAGRAM	16~20
DISASSEMBLY INSTRUCTIONS	4,5	RESISTORS, CAPACITORS &	
MEASUREMENTS AND ADJUSTMENTS	5,6	REPLACEMENT PARTS LIST	21,22
PRINTED CIRCUIT BOARDS	7~10	EXPLODED VIEWS	23,24
WIRING CONNECTION DIAGRAM	11,12		

### SAFETY PRECAUTION

1. Before servicing, unplug the power cord to prevent an electric shock.
2. When replacing parts, use only manufacturer's recommended components for safety.
3. Check the condition of the power cord. Replace if wear or damage is evident.
4. After servicing, be sure to restore the lead dress, insulation barriers, insulation papers, shields, etc.
5. Before returning the serviced equipment to the customer, be sure to make the following insulation resistance test to prevent the customer from being exposed to a shock hazard.

### INSULATION RESISTANCE TEST

1. Unplug the power cord and short the two prongs of the plug with a jumper wire.
2. Turn on the power switch.
3. Measure the resistance value with ohmmeter between the jumpered AC plug and each exposed metal cabinet part, such as screwheads antenna, control shafts, handle brackets, etc. Equipment with antenna terminals should read between 3M $\Omega$  and 5.2M $\Omega$  to all exposed parts. (Fig. A) Equipment without antenna terminals should read approximately infinity to all exposed parts. (Fig. B)

**Note:** Some exposed parts may be isolated from the chassis by design. These will read infinity.

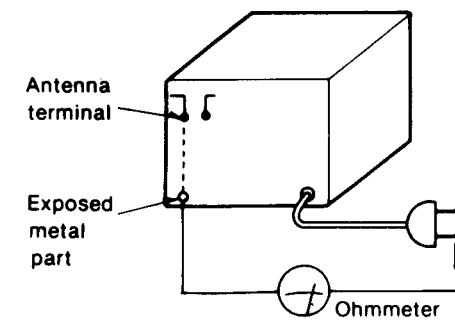

(Fig. A)

Resistance = 3M $\Omega$  - 5.2M $\Omega$

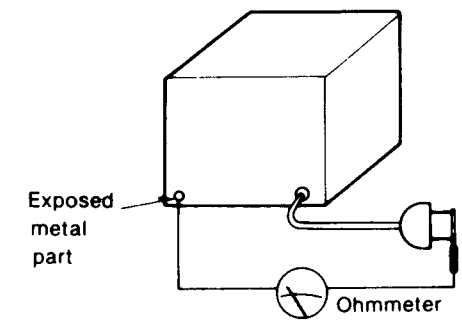

(Fig. B)

Resistance = Approx  $\infty$

4. If the measurement is outside the specified limits, there is a possibility of a shock hazard. The equipment should be repaired and rechecked before it is returned to the customer.

## LOCATION OF CONTROLS

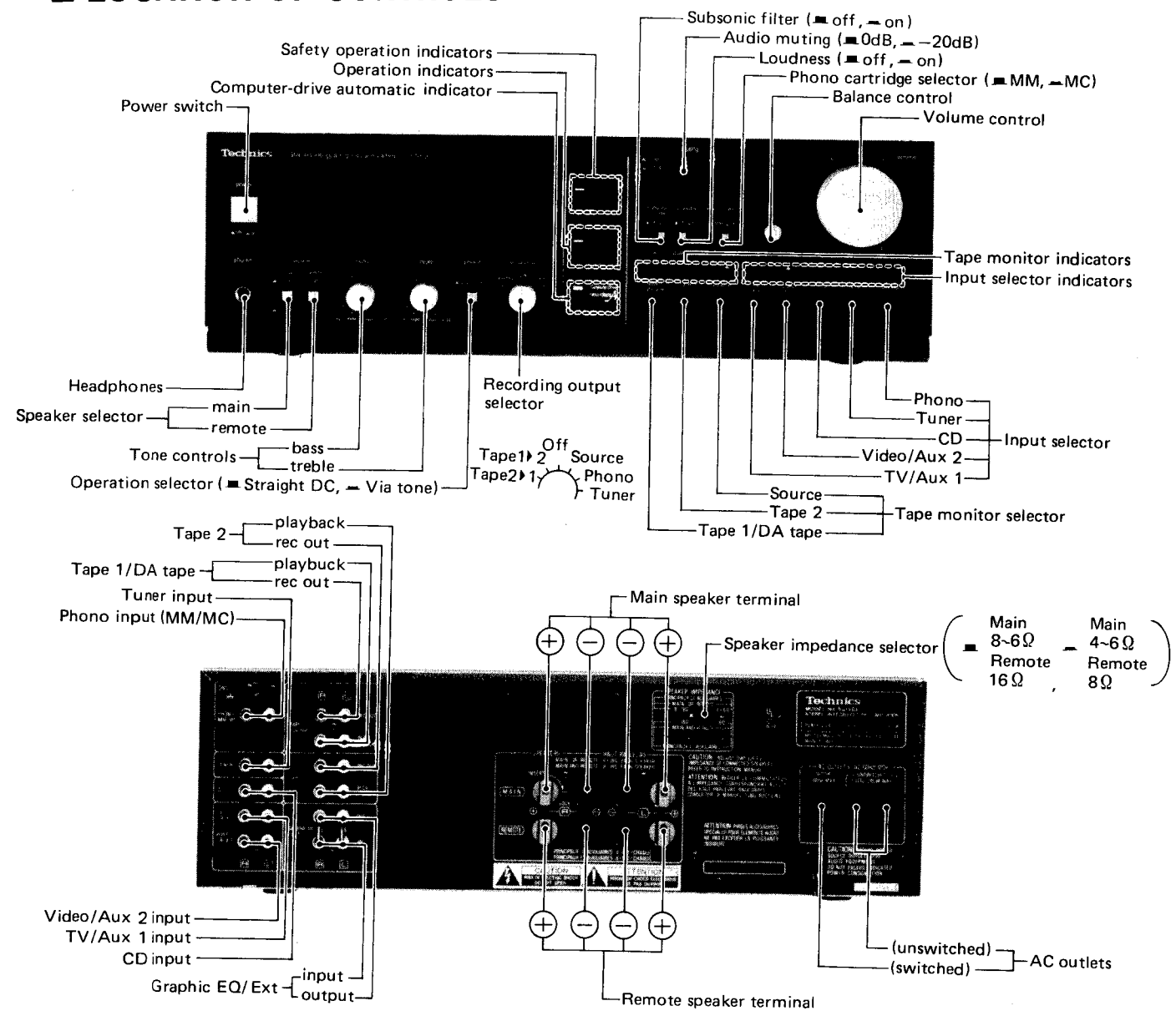

\*Phono input capacitance is about 150pF

### Speaker impedance selector

Set to the position corresponding to the impedance of the speaker systems being used. If this setting is not correctly made, the result may be a deterioration of performance.

- If either the main or the remote speaker systems are used:
  - 4~6Ω (Main): For speaker impedance of 4~6Ω.
  - 8~16Ω (Remote): For speaker impedance of 8~16Ω.
- If both main and remote speaker systems are used:
  - 8Ω (Main): For speaker impedance of 8Ω or more and less than 16Ω.
  - 16Ω (Remote): For speaker impedance of 16Ω.

• When units are stacked  
If the rear feet must be removed (because the unit below is smaller), attach the two feet at a position more toward the front.

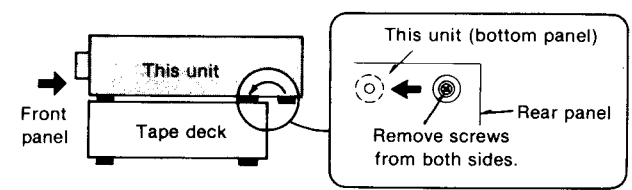

## PROTECTION CIRCUITRY

The protection circuitry may have operated if either of the following conditions is noticed:

- No sound is heard when the power is turned on.
- Sound stops during a performance.

The function of this circuitry is to prevent circuitry damage if, for example, the positive and negative speaker connection wires are "shorted", or if speaker systems with an impedance less than the indicated rated impedance of this unit are used.

If this occurs, follow the procedure outlines below:

1. Turn off the power.
2. Determine the cause of the problem and correct it.
3. Turn on the power once again after one minute.

**Note**  
When the protection circuitry functions, the unit will not operate unless the power is first turned off and then on again.

## BEFORE REPAIR AND ADJUSTMENT

1. Turn off the power supply and short-circuit of power supply capacitors (C701, C702, 15,000μF) at resistance (about 10Ω, 5W) in order to discharge the charged voltage. Do not short between C701 and C702 by screwdriver. It may damage the component.
2. Before turning on the power supply after completion of repair, slowly apply the primary voltage by using a power supply voltage controller to make sure that the consumed current at 120V, 60Hz in no-signal mode is 330 ~ 600mA.

## DISASSEMBLY INSTRUCTIONS

Ref.No.	How to remove the cabinet	Ref. No.	How to remove the front panel
1		2	
Procedure 1	<ul style="list-style-type: none"> <li>• Remove the 6 setscrews</li> </ul>	Procedure 1 → 2	<ul style="list-style-type: none"> <li>• Remove the 5 setscrews of front panel.</li> <li>• Pull out the volume control knob and remove the nut ⑥.</li> <li>• Pull out the connector terminals (J602 ~ J605) and remove the front panel in the direction of the arrow (→).</li> </ul>

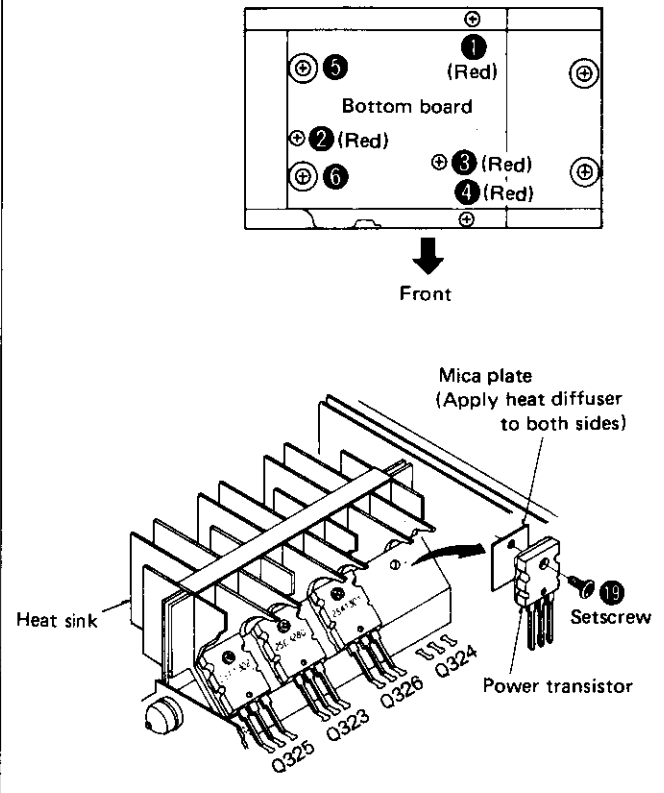
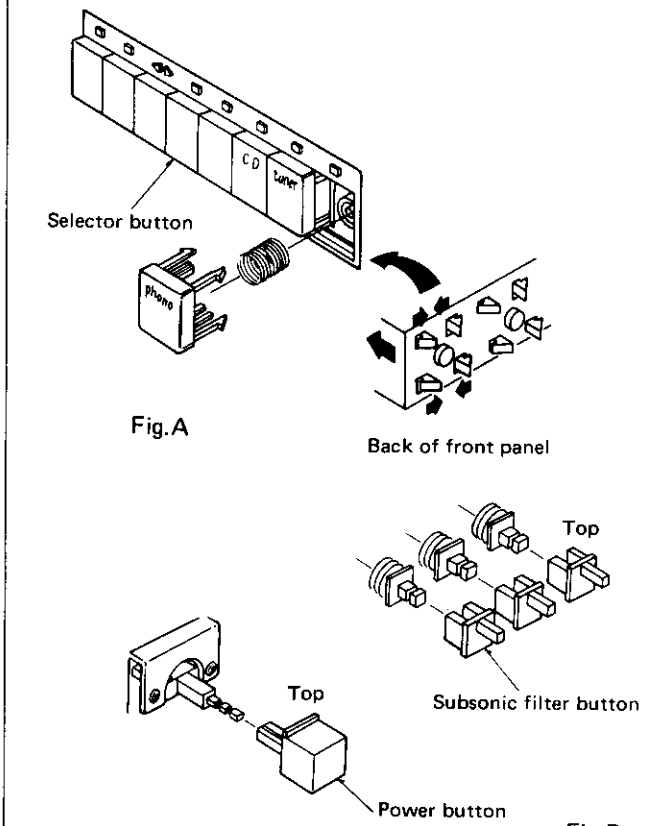
Ref. No. 3	How to remove the Power Transistors	Ref. No. 4	How to remove the selector and push button
<p><b>Procedure 1 → 3</b></p>	<ul style="list-style-type: none"> <li>Remove the 6 setscrews of bottom board</li> <li>Remove the setscrew of power transistor</li> <li>When mounting the power Transistors, apply heat diffuser to both sides of mica plate.</li> </ul>  <p>When mounting the Power Transistors, apply silicone compound (SZZOL15) equivalent heat diffuser to the rear side of the mica plate (AC-262) and Power Transistors.</p>	<p><b>Procedure 1 → 2 → 4</b></p> <ul style="list-style-type: none"> <li>Remove the claw (Fig. A) that fastens the selector button from the back of front panel, and push it forward.</li> <li>Fit the power switch button and subsonic filter switch button in the position as in Fig.B.</li> </ul> 	

5. Adjust VR301 [Lch] or VR302 [Rch] so that the voltage is 20mV about 15 ~ 20min after power switch "on".  
 \* In this set, ICQ is controlled by a microcomputer, and ICQ a little more than the normal level is applied by "PRE-HEAT" for about 14 ~ 16sec after power ON. After that, the output level and transistor temperature are detected by AUTO there automatically controlling ICQ.

**2. Check of Muting with Power On/Off.**

1. Connect AC voltmeter and 8Ω load (resistor or speaker) to main speaker terminals.
2. Set the sound volume to a proper level.
3. Apply 1 kHz 100 mV signal to AUX input terminal.
4. Make sure that output is gained 3 ~ 5 sec. after power switch "on" and that the output goes out immediately after power switch "off".

**3. Check of Over load detection and Protection circuit**

1. Set the volume control to maximum.
2. Connect the audio oscillator to the AUX terminal and apply the input signal of 1 kHz to the terminal. Then adjust the output level of the audio oscillator so that the output level of the speaker terminals becomes 1.5V.
3. With main speaker terminals [Lch] short-circuited by lead wire (as thick and short as possible):
  - Make sure [ - relay is off.
  - [ - "auto" indicator "on" goes out.
  - [ - "safty operation" indicator blinks.
4. When relay is off, turn power "off" and unit for a while before turning it "on". Otherwise, the original conditions are not restored even when the circuit and load are normal.

**4. Check of DC Detection Circuit**

1. Set the input selector to the "tuner" position.
2. Apply DC voltage +1V [Lch] the tape1 playback terminal. -1V [Rch] to the tape2 playback terminal.
3. Set the input selector to the "tape1" position.
  - Make sure [ - relay is off.
  - [ - "auto" indicator "on" goes out.
  - [ - "safty operation" indicator blinks.

**• Adjustments points**

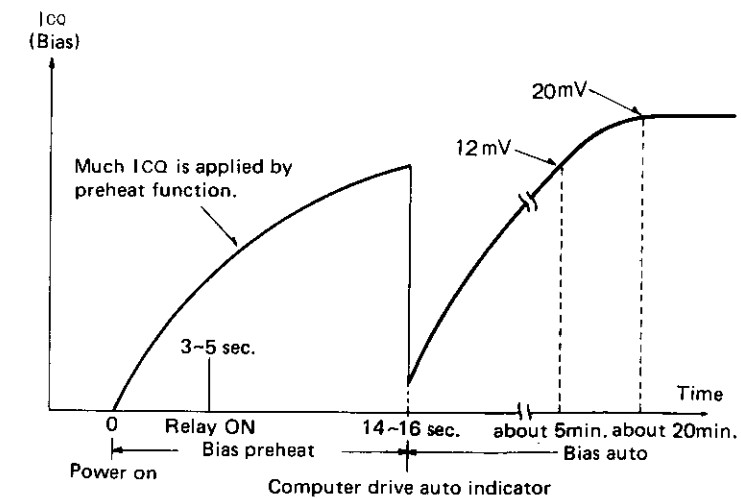
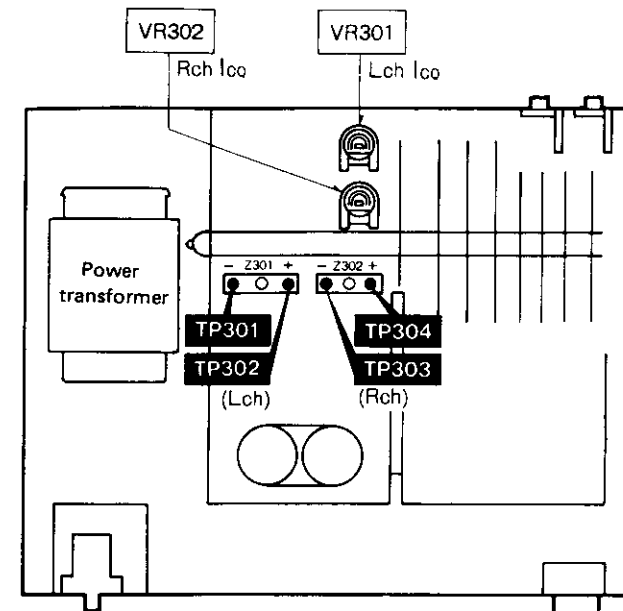

**■ MEASUREMENTS AND ADJUSTMENTS**

**• Setting and Equipment used**

1. Audio oscillator.
2. AC, DC, electronic voltmeters (VTVM).
3. Frequency counter.
4. Oscilloscope.

**1. Idling (ICQ) Adjustment (after repairing the main amp)**

1. After the repair, set the sound volume to minimum before turning on the power switch, and connect nothing to the speaker terminals.
2. Completely turn ICQ control (VR301, 302) counter-clockwise.
3. Increase the voltage applied to the amplifier gradually from 0V by means of a power supply voltage controller and make sure of the that the consumed current 120V 60Hz in no-signal mode is 330 ~ 600mA before adjustment.
4. Connect the DC electronic voltmeter to TP302 (+) and TP301 (-) [Lch] or TP304 (+) and TP303 (-) [Rch].

# SU-V6X SU-V6X

## PRINTED CIRCUIT BOARDS

- SPEAKER INPEDANCE TO BE CHANGED AND THE AREAS

For the U.S.A ([M] area)

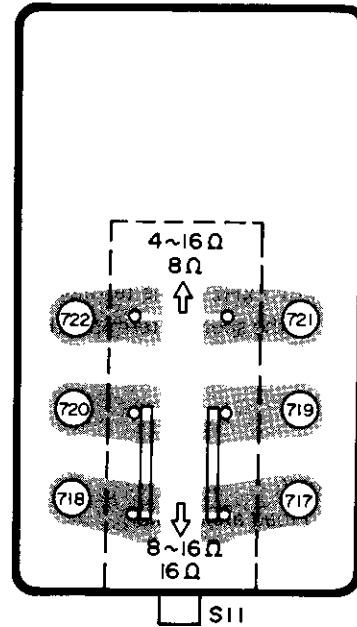

**O** SPERKER IMPEDANCE P.C.B.

For Canada ([MC] area)

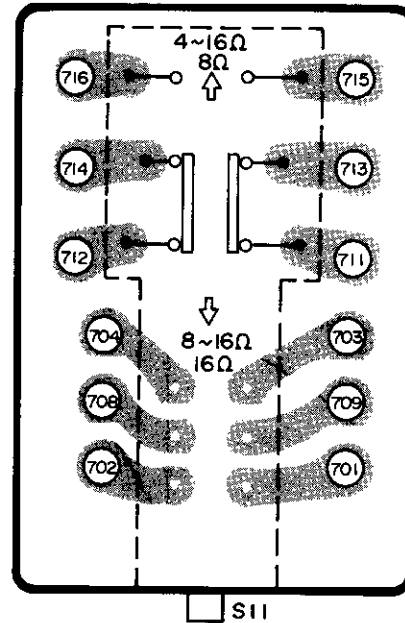

**O** SPEAKER IMPEDANCE P.C.B.

**N** POWER SWITCH P.C.B.

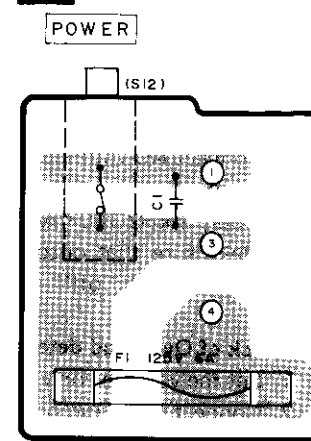

**M** SPEAKER SELECTOR P.C.B.

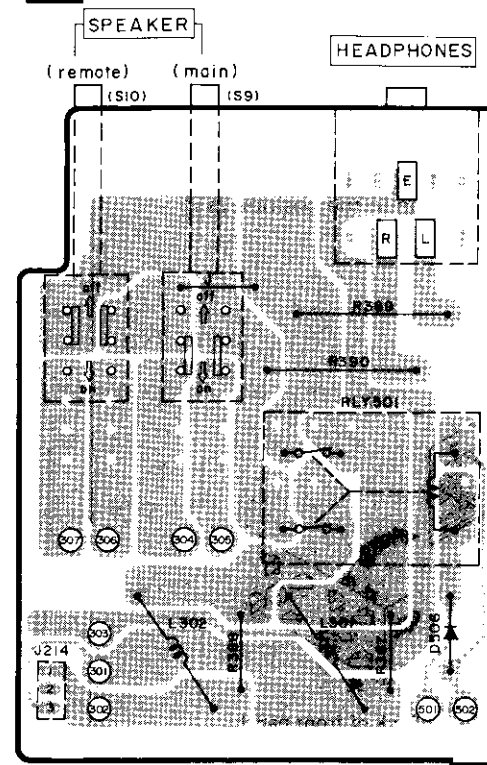

**K** POWER AMP/POWER P.C.B.

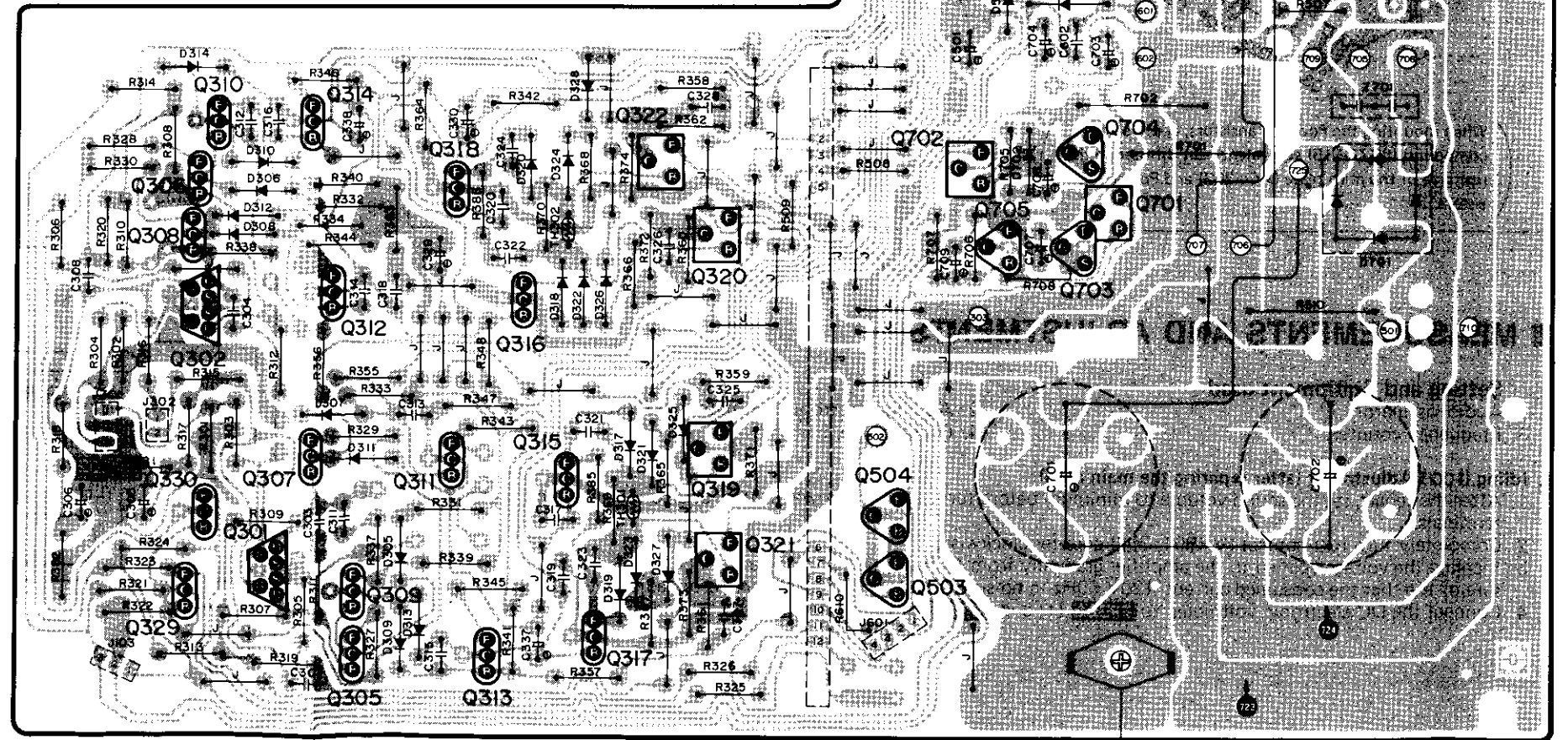

# SU-V6X SU-V6X

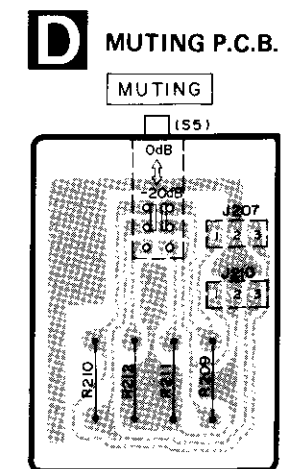
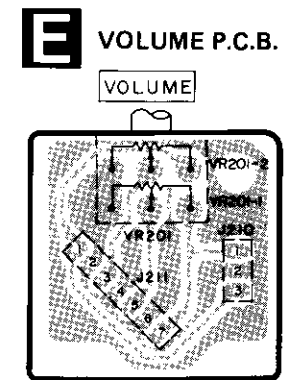
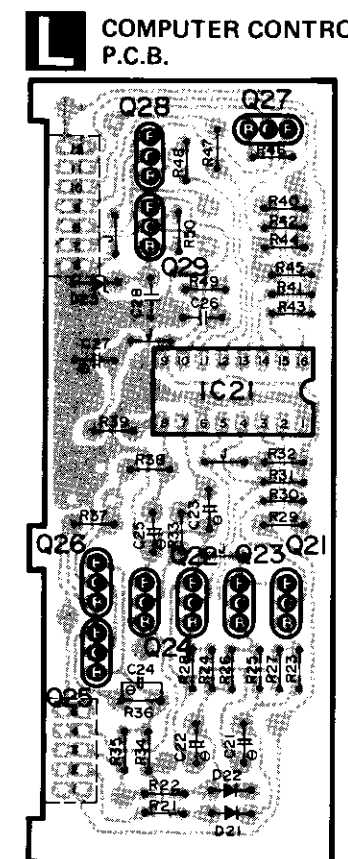
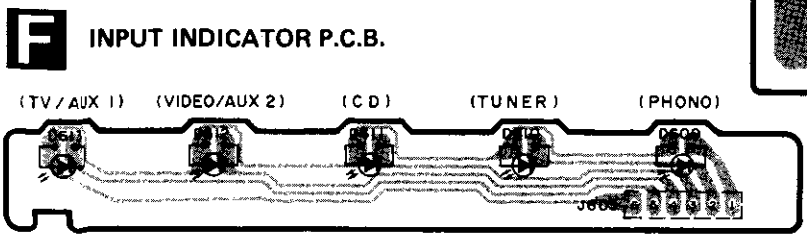
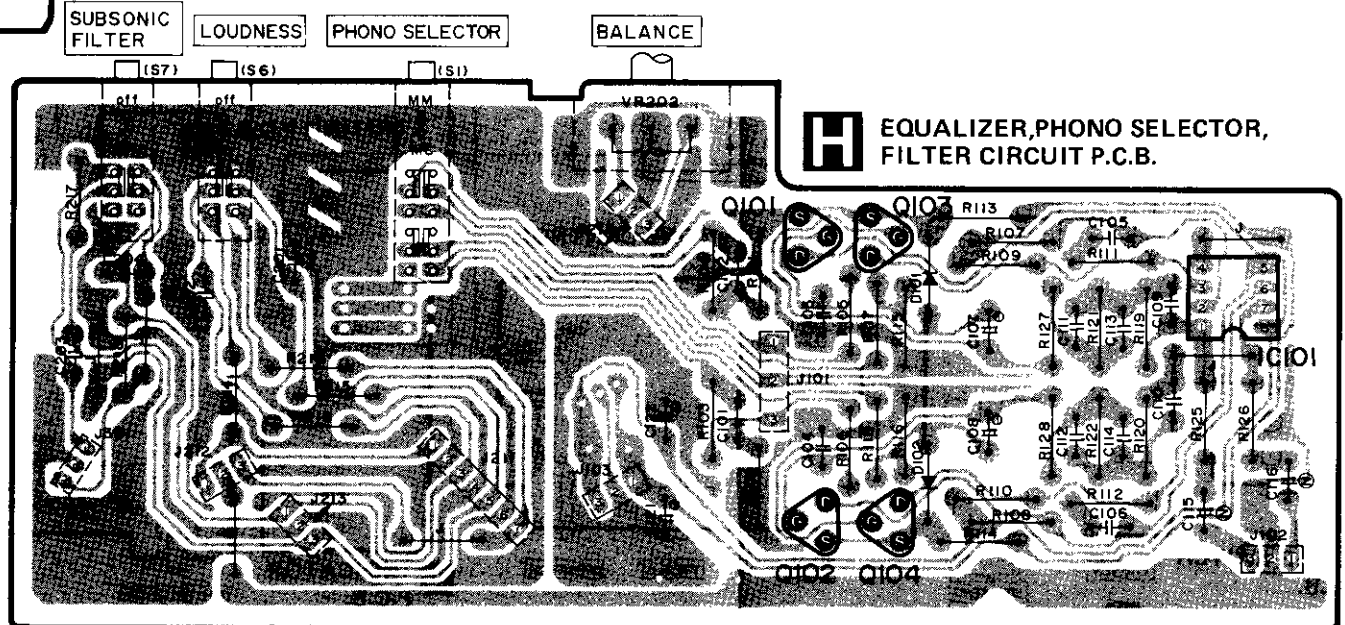
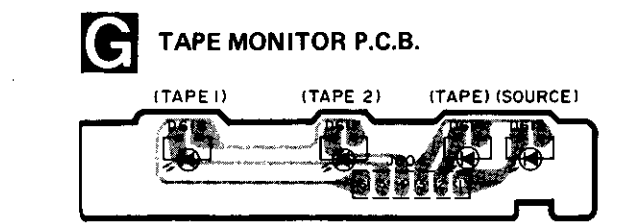
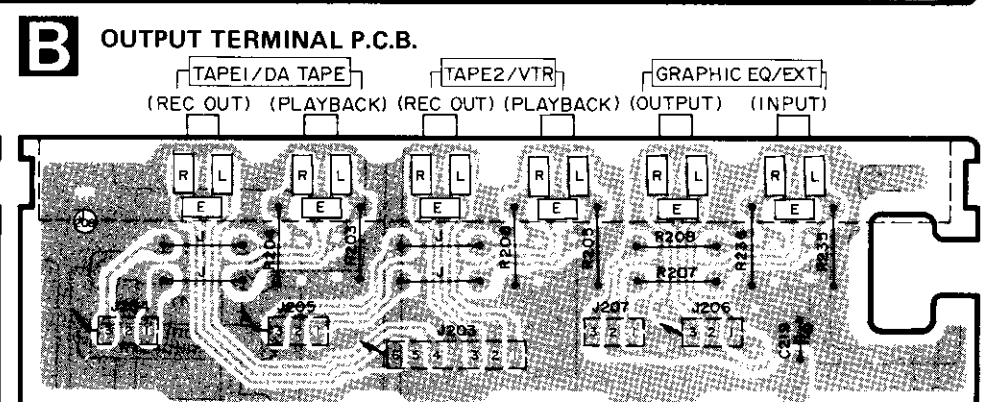
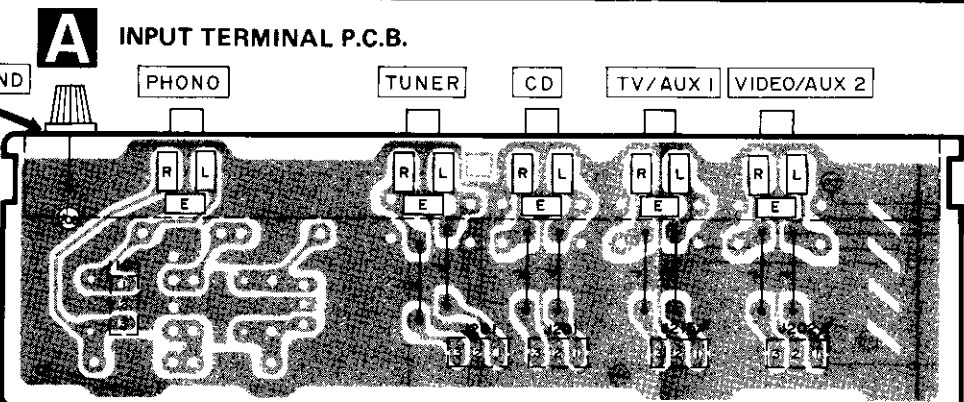
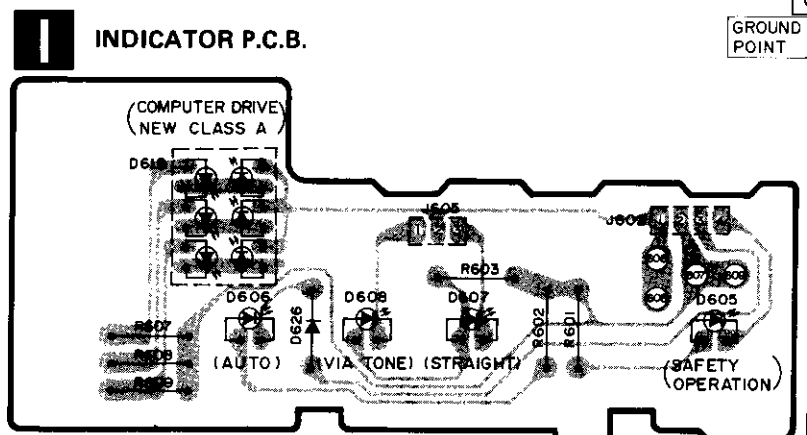
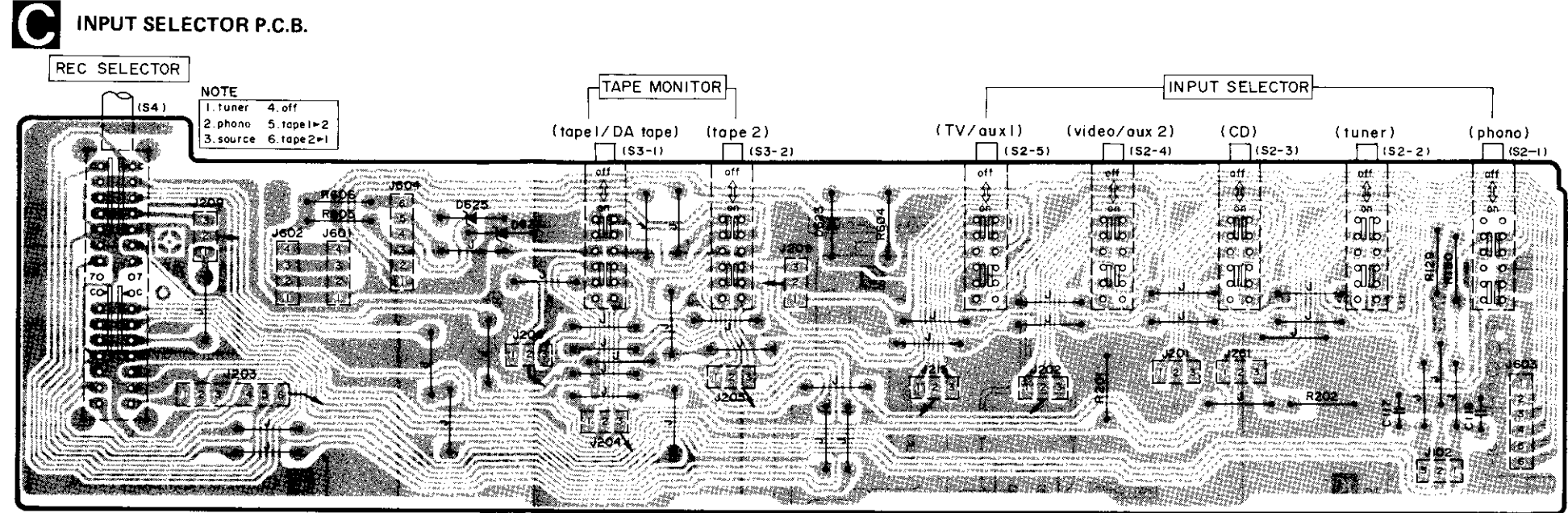
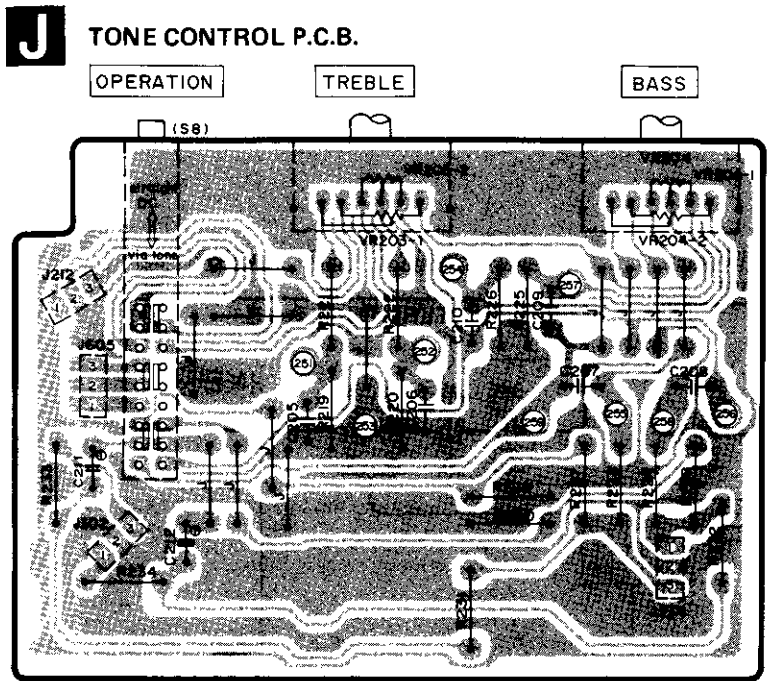

## WIRING CONNECTION DIAGRAM

For Canada ([MC] area)

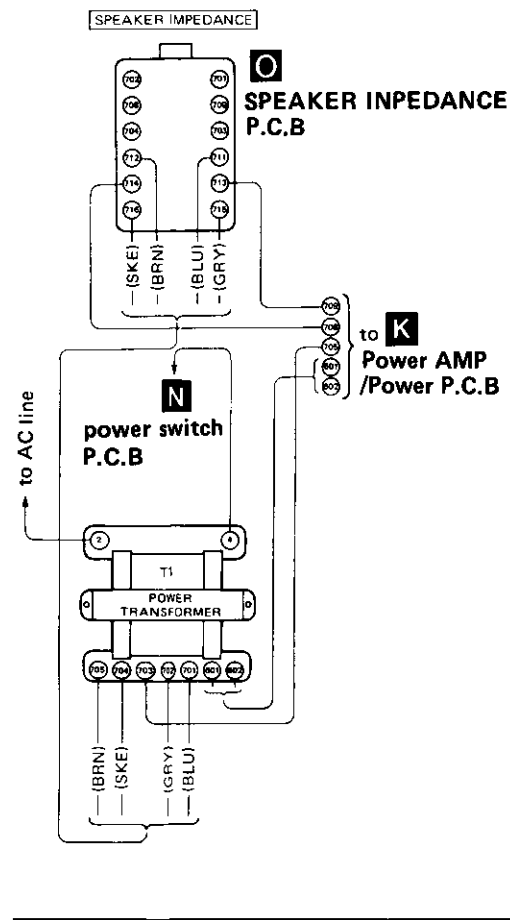

For the U.S.A. ([M] area)

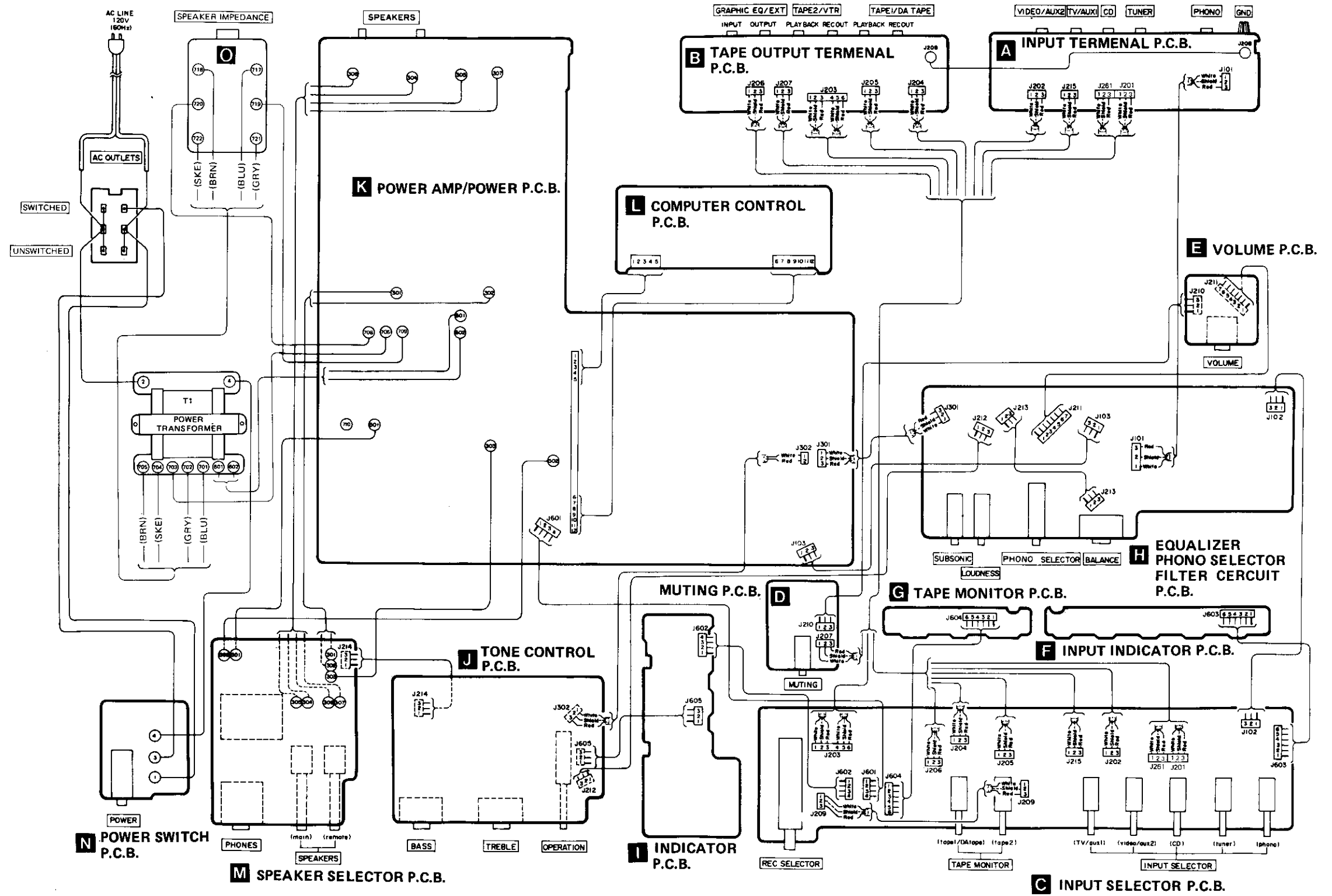

■ BLOCK DIAGRAM

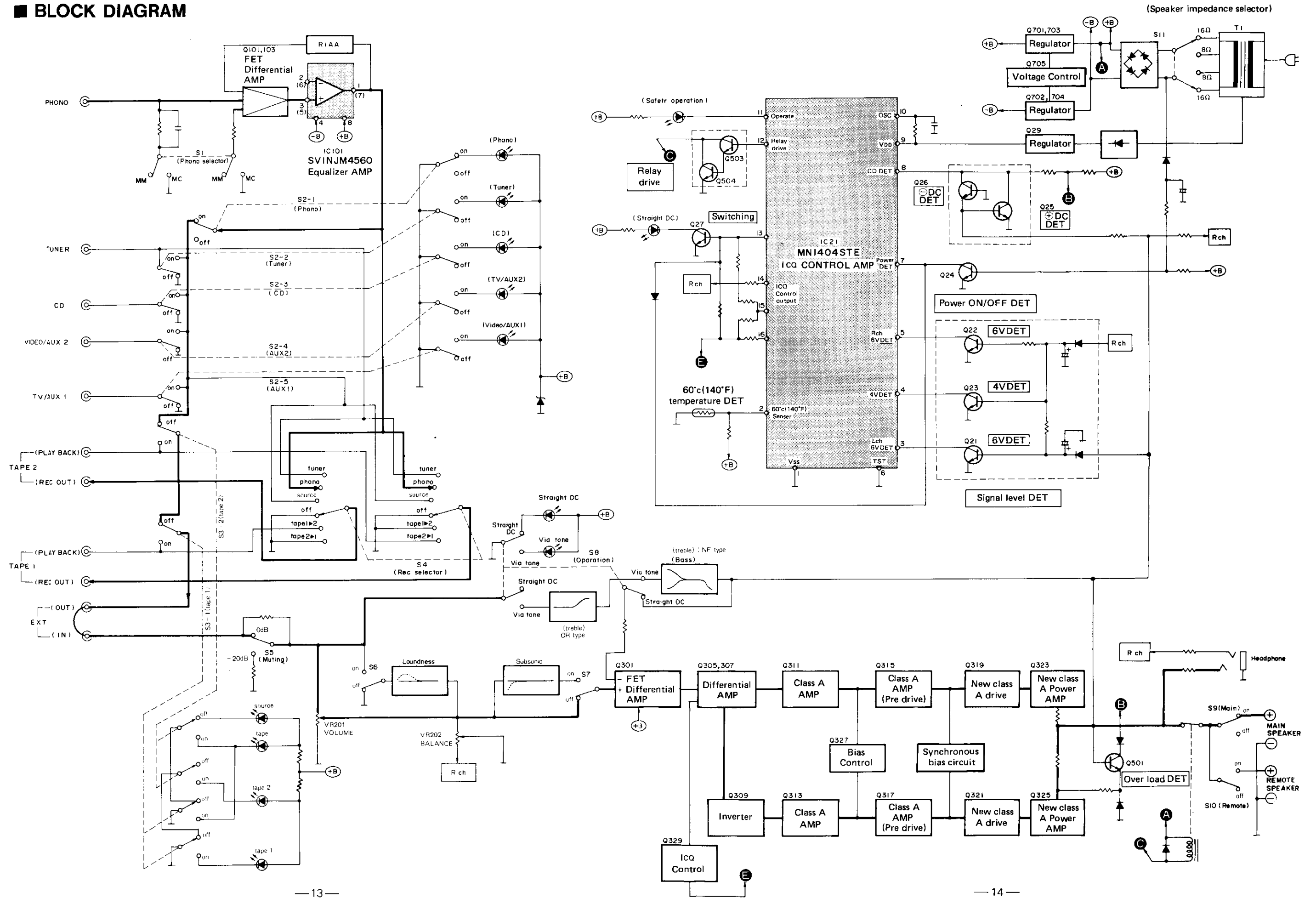

## FUNCTION OF TERMINAL (Ico CONTROLLER IC 21)

No.	Symbol	Name of block	Description of terminal
1	VSS	Power supply input terminal	Grounded. (0V)
2	A13	Input port A	Temperature detection circuit. When 60°C (140°F) sensor of power amplifier operates, "H" is put in causing the outputs of terminals 14 ~ 16 to go "H".
3	A12		When effective output 5V signal sensor of L-ch power amplifier operates, "L" is put in causing the output of terminal 14 to go "H".
4	A11		When effective output 2V signal sensors of both-ch power amplifiers operate, "L" is put in causing the output of terminal 15 to go "H".
5	A10		When effective output 5V signal sensor of R-ch power amplifier operates, "L" is put in causing the output of terminal 16 to go "H".
6	TST	Test input terminal	Terminal for testing LSI. (Ground)
7	RST	Reset input terminal	All outputs are cleared or reset with input at "L". (It is connected to power supply circuit)
8	SNSO	Sensor input terminal	When overload detection circuit of power amplifier output operates, "L" is put in causing the output of terminal 12 to go "L".
9	VDD	Power supply input terminal	Apply 5V.
10	OSC	OSC input terminal	Clock signal (about 415kHz) can be obtained by internal oscillation circuit.
11	CO5	Output port C	When protection circuit operates, "H" and "L" outputs are repeated and "safety operation" indicator blinks.
12	CO4		Output relay and meter relay turn ON with "H" output.
13	CO3		Indicator "auto" lights up at "H".
14	CO2		ICQ control signal is emitted from A input port (temp. sensor, signal sensor). ("H" output)
15	CO1		
16	CO0		

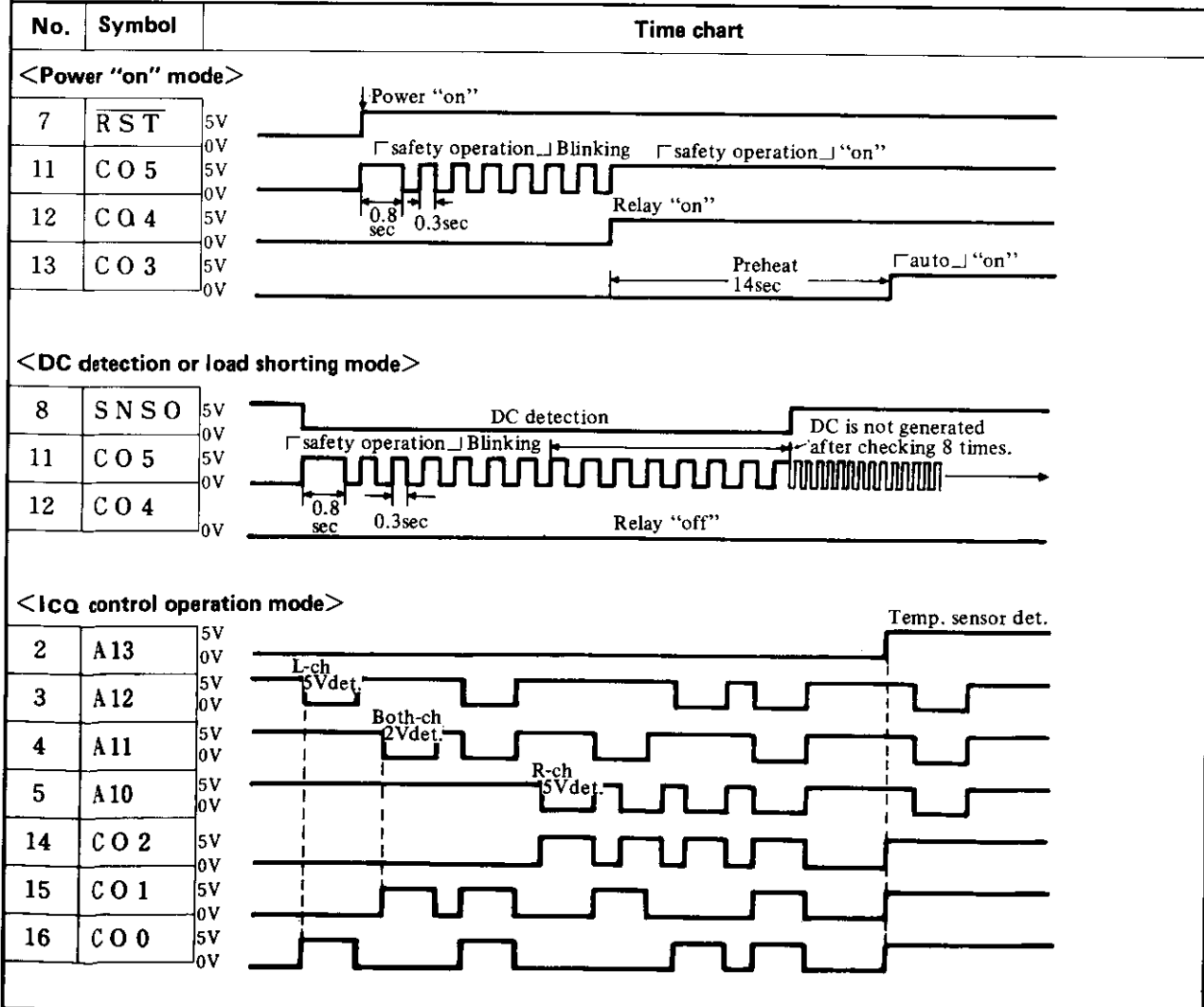

## SCHEMATIC DIAGRAM

(This schematic diagram may be modified at any time with the development of new technology.)

The part No. of transistors, IC and diodes mentioned in the schematic diagram stand for production part No. Regarding the part No. with ⊕ mark, the production part No. are different from the replacement part No. Therefore, when placing an order for replacement parts, please use the part No. in the replacement parts list.

### Notes:

- S1** : Phono cartridge selector switch in "MM" position. (MM → MC)
- S2-1 ~ 2-5** : Input selector switch in "Phono" position.  
**S2-1** : Phono                      **S2-4** : Video/aux 2  
**S2-2** : Tuner                      **S2-5** : TV/aux 1  
**S2-3** : CD
- S3-1 ~ 3-2** : Tape monitor selector switch in "off" position.  
**S3-1** : Tape 1/DA tape    **S3-2** : Tape 2
- S4** : Recording output selector in "off" position. (Tape 2 → 1 → 2 → off → source → phono → tuner)
- S5** : Audio muting switch in "OdB" position. (OdB → -20dB)
- S6** : Loudness switch in "off" position.
- S7** : Subsonic filter switch in "off" position.
- S8** : Operation switch in "straight DC" position. (straight DC → via tone)
- S9** : Main speaker switch in "on" position. (off → on)
- S10** : Remoto speaker switch in "off" position. (off → on)
- S11** : Speaker impedance selector switch in "8 ~ 16Ω / 16Ω" position. (8 ~ 16Ω / 16Ω → 4 ~ 6Ω / 8Ω)
- S12** : Power switch in "on" position.

## TERMINAL GUIDE OF TRANSISTORS, DIODES AND IC'S

 No.1 MN1404STE 16pin SVINJM4560DX 8pin	SVDS10VB20F	LN0603GP3G	MA162, MA27W-A	2SK369
	 MA1062M, MA182 MA1030,	 SVDAY5533K SVDPR5533K-M	 K A K A	 DRAIN GATE SOURCE
2SA1112, 2SC2592	2SA1123, 1124 2SC1815, 1845, 2631 2SC2632	 K A K A	 A K	 K A K A
 B C E	 E C B	 K A K A	 A K	 K A K A
2SK389	2SA1301, 2SC3280	SVDSR1K2	LN446YP, LN846RP LN346GP	0A90
 1. D1 2. G1 3. S1 4. sub 5. S2 6. G2 7. D2	 B C E	 -20dB K A	 A K A K	 K A K A
 D2 D1 G2 G1 S2 S1			 A K A K	 B C E





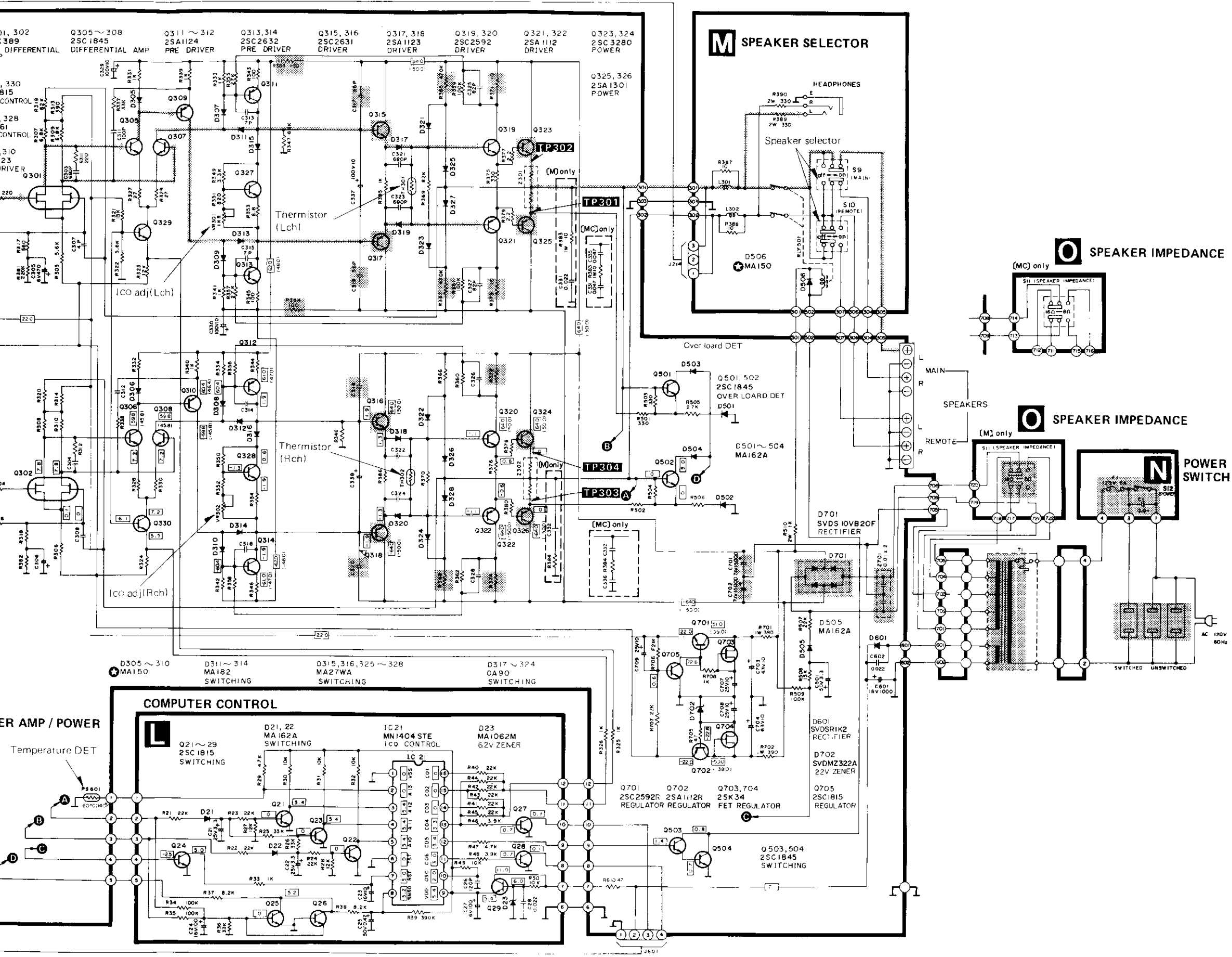

**IMPORTANT SAFETY NOTICE**  
 The shaded area on this schematic diagram incorporates special features important for protection from fire and electrical shock hazards. When servicing it is essential that only manufacturer's specified parts be used for the critical components in the shaded areas of the schematic.

13. Indicated voltage values are the standard values for the unit measured by the DC electronic circuit tester (high-impedance) with the chassis taken as standard. Therefore, there may exist some errors in the voltage values, depending on the internal impedance of the DC circuit tester.
- \*Figures in [ ] stand for DC voltage in Impedance selector switch high (8~16Ω/16Ω) position.
  - \*Figures in ( ) stand for DC voltage in Impedance selector switch low (4~6Ω/8Ω) position.
14. — Positive voltage lines  
 ~~~~~ Phono signal line (Lch)

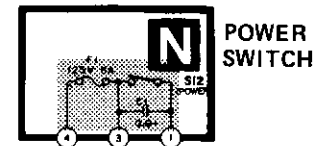
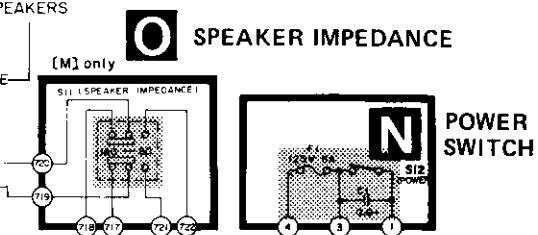
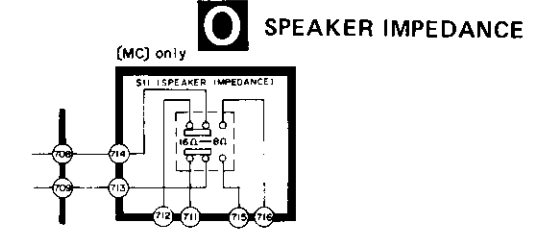

RESISTORS, CAPACITORS & REPLACEMENT PARTS LIST

Notes:

- Part numbers are indicated on most mechanical parts. Please use this part number for parts orders.
- Important safety notice: Components identified by  $\Delta$  mark have special characteristics important for safety. When replacing any of these components use only manufacturer's specified parts.
- The "S" mark is service standard parts and may differ from production parts.
- The unit of resistance is  $\Omega$  (ohm), K = 1000 $\Omega$ , M = 1000k $\Omega$ .
- The unit of capacitance is  $\mu$ F (microfarad), P = 10<sup>-6</sup>  $\mu$ F.

Numbering System of Resistor

Example

|      |         |       |           |       |
|------|---------|-------|-----------|-------|
| ERD  | 25      | F     | J         | 101   |
| Type | Wattage | Shape | Tolerance | Value |
| ERG  | 2       | AN    | J         | 2R2   |
| Type | Wattage | Shape | Tolerance | Value |

Numbering System of Capacitor

Example

|      |         |       |           |             |      |         |                 |       |             |
|------|---------|-------|-----------|-------------|------|---------|-----------------|-------|-------------|
| ECKD | 1H      | 103   | Z         | F           | ECEA | 50      | M               | R47   | R           |
| Type | Voltage | Value | Tolerance | Peculiarity | Type | Voltage | Peculiarity use | Value | Special use |

| Capacitor Type | Voltage   |        | Tolerance           |
|----------------|-----------|--------|---------------------|
|                | ECEA Type | Others |                     |
| ECEA           | 1A        | 10V    | C : $\pm 0.25\mu$ F |
| ECET           | 1C        | 16V    | K : $\pm 10\%$      |
| ECEA...N       | 1E        | 25V    | Z : +80%, -20%      |
| ECCD           | 1H        | 50V    | J : $\pm 5\%$       |
| ECKD           | 50        | 50V    |                     |
| ECQM           | 0J        | 6.3V   |                     |
|                | 2A        | 100V   |                     |

| Resistor Type     | Wattage   | Tolerance      |
|-------------------|-----------|----------------|
| ERD : Carbon      | 10 : 1/8W | J : $\pm 5\%$  |
| ERG : Metal Oxide | 25 : 1/4W | G : $\pm 2\%$  |
| ERO : Metal Film  | 2 : 2W    | K : $\pm 10\%$ |

ERD10TLJ□□□ → Chip type carbon  
 ERO10MKG□□□ → Chip type metal film

CAPACITORS

| Ref. No.  | Part No.     | Value  | Ref. No.  | Part No.    | Value  | Ref. No.  | Part No.    | Value | Ref. No.  | Part No.    | Value |
|-----------|--------------|--------|-----------|-------------|--------|-----------|-------------|-------|-----------|-------------|-------|
| C1        | ECKDKC103PF2 | 0.01   | C111, 112 | ECQM1H103JZ | 0.01   | C305, 306 | ECEAJU471   | 470   | C331, 332 | ECKD1H473ZF | 0.047 |
| C21, 22   | ECEAEU3R3    | 3.3    | C113, 114 | ECQM1H332JV | 0.0033 | C307, 308 | ECCD1H040CC | 4P    | C335, 336 | ECKD1H473ZF | 0.047 |
| C23       | ECEA1CU100   | 10     | C115, 116 | ECEA1EN3R3S | 3.3    | C311, 312 | ECCD1H101K  | 100P  |           |             |       |
| C24       | ECEA1CU101   | 100    | C117, 118 | ECQM1H103JZ | 0.01   | C313, 314 | ECCD2H070D  | 7P    |           |             |       |
| C25       | ECEA1HUR47   | 0.47   | C121, 122 | ECEA1EU470  | 47     | C315, 316 | ECCD2H070D  | 7P    | C337, 338 | ECEA2AU100  | 10    |
| C26       | ECCD1H121K   | 120P   | C201, 202 | ECQM1H563KV | 0.056  | C317, 318 | ECCD2H560K  | 56P   | C501      | ECEA1HU3R3  | 3.3   |
| C27       | ECEAJU101    | 100    | C203, 204 | ECQM1H273KV | 0.027  | C319, 320 | ECCD2H560K  | 56P   | C601      | ECEA1CU102  | 1000  |
| C28       | ECKD1H223ZF  | 0.022  | C205, 206 | ECQM1H223JZ | 0.022  | C321, 322 | ECKD1H681KB | 680P  | C602      | ECKD1H223ZF | 0.022 |
| C101, 102 | ECKD1H103ZF  | 0.01   | C207, 208 | ECQM1H183KV | 0.018  | C323, 324 | ECKD1H681KB | 680P  | C701, 702 | ECEA1H153Z  | 15000 |
| C103, 104 | ECCD1H820K   | 82P    | C209, 210 | ECQM1H823JZ | 0.082  | C325, 326 | ECCD1H820K  | 82P   | C703, 704 | ECEA1JS100  | 10    |
|           |              |        |           |             |        | C327, 328 | ECCD1H820K  | 82P   |           |             |       |
| C105, 106 | ECKD1H222KB  | 0.0022 | C211, 212 | ECEA1EU4R7  | 4.7    | C329, 330 | ECEA2AU100  | 10    | C707, 708 | ECEA1EU100  | 10    |
| C107, 108 | ECEAJU222    | 2200   | C219      | ECEAJU101   | 100    | C331, 332 | ECKD1H223ZF | 0.022 | C709      | ECEA1EU100  | 10    |
| C109, 110 | ECQM1H473JZ  | 0.047  | C303, 304 | ECKD1H681KB | 680P   |           |             |       |           |             |       |

| Ref. No.                                              | Part No.     | Part Name & Description                                     |
|-------------------------------------------------------|--------------|-------------------------------------------------------------|
| <b>INTEGRATED CIRCUITS</b>                            |              |                                                             |
| IC21                                                  | MN1404STE    | ICQ Control                                                 |
| IC101                                                 | SVINJM4560DX | Equalizer AMP                                               |
| <b>TRANSISTORS</b>                                    |              |                                                             |
| Q21~29                                                | 2SC1815-Y    | Switching                                                   |
| Q101~104                                              | 2SK369-GR    | FET Differential AMP                                        |
| (Use pair ranks as same as Q101, Q102, Q103 and Q104) |              |                                                             |
| Q301, 302                                             | 2SK389-GR    | FET Differential AMP                                        |
| Q305~308, 501~504                                     | 2SC1845-E    | FET Differential AMP, Over Load Deft, Relay Drive, Inverter |
| Q309, 310                                             | 2SA1123-R    | A Class AMP                                                 |
| Q311, 312                                             | 2SA1124-R    | A Class AMP                                                 |
| Q313, 314                                             | 2SC2632-R    | Pre Drive                                                   |
| Q315, 316                                             | 2SC2631-Q    | Pre Drive                                                   |
| Q317, 318                                             | 2SA1123-S    | Pre Drive                                                   |
| (Use pair ranks as same as Q315, Q316, Q317 and Q318) |              |                                                             |
| Q319, 320                                             | 2SC2592-R    | Drive                                                       |
| Q321, 322                                             | 2SA1112-R    | Drive                                                       |
| (Use pair ranks as same as Q319, Q320, Q321 and Q322) |              |                                                             |
| Q323, 324                                             | 2SC3280-R    | Power AMP                                                   |
| Q325, 326                                             | 2SA1301-R    | Power AMP                                                   |
| (Use pair ranks as same as Q323, Q324, Q325 and Q326) |              |                                                             |
| Q327, 328                                             | 2SD661-S     | Bias Control                                                |
| Q329, 330, 705                                        | 2SC1815-Y    | Bias Control, Regulator                                     |
| Q701                                                  | 2SC2592-R    | Regulator                                                   |
| Q702                                                  | 2SA1112-R    | Regulator                                                   |
| Q703, 704                                             | 2SK34-D1     | Regulator                                                   |
| <b>DIODES</b>                                         |              |                                                             |
| D21, 22                                               | MA162A       | Switching                                                   |
| D23                                                   | MA1062M      | 6.2V Zener                                                  |
| D101, 102, 305~310, 506                               | MA162A       | Switching                                                   |
| D311~314, 403~406                                     | MA182        | Switching                                                   |
| D315, 316, 325~328                                    | MA27W-A      | Switching                                                   |
| D317~324                                              | 20A90        | Switching                                                   |
| D501~505                                              | MA162A       | Signal Rectifier                                            |
| D601                                                  | SVDSR1K2     | Rectifier                                                   |
| D605, 608                                             | LN446YP      | Power, Via Tone IND                                         |
| D606                                                  | LN346GP      | Auto IND                                                    |
| D607                                                  | LN846RP      | Straight DC IND                                             |
| D609~613, 615                                         | SVDP5533K    | Input Selector IND                                          |
| D614, 616, 617                                        | SVDA5533K-M  | Tape Selector IND                                           |
| D618                                                  | LN0603YP4    | New Class A IND                                             |
| D623~626                                              | MA1030       | 3V Zener                                                    |
| D701                                                  | SVDS10VB20F  | 3V Zener Rectifier                                          |
| D702                                                  | SVDMZ322A    | 22V Zener                                                   |
| <b>COILS and TRANSFORMER</b>                          |              |                                                             |
| L301, 302                                             | SLQY15G-30   | Choke                                                       |
| T1                                                    | SLT5Q139     | Power Source                                                |

| Ref. No.                         | Part No.     | Part Name & Description                             |
|----------------------------------|--------------|-----------------------------------------------------|
| <b>VARIABLE RESISTORS</b>        |              |                                                     |
| VR201                            | EWJKMA054B15 | Volume Adj, 100k $\Omega$ (B)                       |
| VR202                            | EWHFKA002G15 | Volume Balance Adj, 100k $\Omega$ (G)               |
| VR203                            | EWCX8A011012 | Tone Adj                                            |
| VR204                            | EWXEA011C15  | Bass Adj                                            |
| VR301, 302                       | EVNKA000B13  | ICQ Adj, 1k $\Omega$ (B)                            |
| <b>FUSE</b>                      |              |                                                     |
| F1                               | XBA1F60NU14  | 125V, 7A                                            |
| <b>COMPONENT COMBINATIONS</b>    |              |                                                     |
| Z301, 302                        | ERF3GBKR22N  | 3W, 0.22 $\Omega$ ( $\times 2$ )                    |
| Z701                             | SXRFS203ZSM  | 0.01 $\mu$ F( $\times 2$ )                          |
| <b>THERMISTORS</b>               |              |                                                     |
| TH301, 302                       | ERTD2ZHL103S | 10k $\Omega$                                        |
| PS601                            | SRPBG47101   | Temperature Det (60 $^{\circ}$ C, 140 $^{\circ}$ F) |
| <b>SWITCHES</b>                  |              |                                                     |
| S1, 6, 7                         | SSH3065      | Phono Selector, Loudness, Subsonic Filter           |
| S2, 3                            | SSH807       | Input Selector, Tape Monitor                        |
| S4                               | SSR189       | Rec Output Selector                                 |
| S5                               | SSH1143      | Audio Muting                                        |
| S8                               | SSH1141      | Operation                                           |
| S9, 10                           | SSH2017      | Speaker Selector                                    |
| S11(M)                           | ESB70221T    | Speaker Impedance Selector                          |
| S11(MC)                          | SSH1157      | Speaker Impedance Selector                          |
| S12                              | SSH1109      | Power Source                                        |
| <b>RELAY</b>                     |              |                                                     |
| RLY501                           | SSY105       | Speaker Protection                                  |
| <b>CABINET and CHASSIS PANTS</b> |              |                                                     |
| 1                                | SGWUV6X-KM   | Front panel Ass'y (1)                               |
| 2                                | SBN993-1     | Knob, Bass, Treble, Rec (3)                         |
| 3                                | SBN1181      | Knob, Balance (1)                                   |
| 4                                | SBN1177      | Knob, Volume (1)                                    |
| 5                                | SBC641-4A    | Button, Phono (1)                                   |
| 6                                | SBC641-4B    | Button, Tuner (1)                                   |
| 7                                | SBC641-4C    | Button, CD (1)                                      |
| 8                                | SBC641-4D    | Button, Video/aux 2 (1)                             |
| 9                                | SBC641-4E    | Button, TV/aux 1 (1)                                |

| Ref. No.                         | Part No.   | Part Name & Description                      |
|----------------------------------|------------|----------------------------------------------|
| <b>CABINET and CHASSIS PANTS</b> |            |                                              |
| 10                               | SBC641-4F  | Button, Source (1)                           |
| 11                               | SBC641-4G  | Button, Tape 2 (1)                           |
| 12                               | SBC641-4H  | Button, Tape 1 (1)                           |
| 13                               | SUS753-1   | Spring, Input Selector (8)                   |
| 14                               | SBC643-2   | Button, Muting (1)                           |
| 15                               | SUS123-3   | Spring, Muting (1)                           |
| 16                               | SBC399T    | Button, Speaker, Operation (3)               |
| 17                               | SBC627     | Button, Power (1)                            |
| 18                               | SBC621     | Button, Subsonic Filter, Loudness, Phono (3) |
| 19                               | SJT345     | Crip, Fuse (2)                               |
| 20                               | SJJ71B     | Jack, Headphone(1)                           |
| 21                               | SML107-7   | Plate, Power Transformer (1)                 |
| 22                               | SKU8990-4  | Bottom Board (1)                             |
| 23                               | SKL249     | Foot (4)                                     |
| 24                               | SMN1893    | Fix Plate (1)                                |
| 25                               | SJF4815-1  | Terminal Board, Speaker (1)                  |
| 26                               | SJF3059-8N | Terminal Board, Tape 1, Tape 2 (1)           |
| 27                               | SJF3059-2N | Terminal Board, Source input (1)             |
| 28(M)                            | SGPUV6X-KM | Rear Panel Ass'y (1)                         |
| 28(MC)                           | SGPUV6X-KC | Rear Panel Ass'y (1)                         |
| 29(M)                            | RJA9Y      | AC Cord (1)                                  |
| 29(MC)                           | SJA109     | AC Cord (1)                                  |
| 30(M)                            | SJS601-3   | Socket, AC Outlet (1)                        |
| 30(MC)                           | SJS603     | Socket, AC Outlet (1)                        |
| 31                               | SKC1590BB2 | Cabinet (1)                                  |
| 32                               | SHR9717    | Holder, P. C. B. (1)                         |
| 33                               | SHR9720    | Holder, P. C. B. (1)                         |
| 34                               | SJP9205-2  | Pin, (2)                                     |
| 35(M)                            | RHR111     | Bushing (1)                                  |
| 35(MC)                           | SHR129     | Bushing (1)                                  |
| 36                               | SUW2827-1  | Plate, Speaker Switch (1)                    |
| 37                               | SBC527     | Button, Impedance Selector (1)               |
| 38                               | SJT3319    | Post(3 pin) (1)                              |
| 38                               | SJT3213    | Post(2 pin) (1)                              |
| 39                               | SJS5331    | Socket(3 pin) (1)                            |
| 39                               | SJS5629    | Socket(6 pin) (1)                            |
| 40                               | SJT783     | Terminal (1)                                 |

SCREWS, WASHERS and NUTS

| Ref. No. | Part No.   | Value |
|----------|------------|-------|
| N1       | XTB3+8BFZ  |       |
| N2       | XTB3+8BFZ  |       |
| N3       | XSN3+6S    |       |
| N4       | XWA3B      |       |
| N5       | XSN3+6S    |       |
| N6       | XWA3B      |       |
| N7       | XSN3+6S    |       |
| N8       | XWA3B      |       |
| N9       | XSN3+6S    |       |
| N10      | XWA3B      |       |
| N11      | SNE4021    |       |
| N12      | SNE4021    |       |
| N13      | SNE4021    |       |
| N14      | XTB3+8BFZ  |       |
| N15      | XTB3+10BFN |       |
| N16      | XWG3       |       |
| N17      | XTB4+10BFN |       |
| N18      | XTB3+6BFZ  |       |
| N19      | XTB3+6BFZ  |       |
| N20      | XTB3+8BFZ  |       |
| N21      | XTB3+8BFZ  |       |
| N22      | XTB3+8BFZ  |       |
| N23      | SNE2095-5  |       |
| N24      | XSN3+6FZS  |       |

PACKING PARTS

|        |           |
|--------|-----------|
| P1(M)  | SPG4820   |
| P1(MC) | SPG4824   |
| P2     | SPS4289-4 |
| P3     | SPS4291-4 |
| P4     | SPP730    |

ACCESSORIES

|        |          |
|--------|----------|
| A1(M)  | SQF12050 |
| A1(MC) | SQF12051 |

