

Service Manual



Direct Drive Automatic Turntable System

SL-1700MK2

(XG), (XGF), (XGB),
(E), (XA), (XGE)

SL-1700MK2A

(XA), (XG), (E)

SL-1710MK2

(XG), (E)

SL-1710MK2A

(XG), (E)

- The model SL-1700MK2 (XG), SL-1700MK2A (XG), SL-1710MK2 (XG) and SL-1710MK2A (XG) are available in European only.
- The model SL-1700MK2 (XGF) is available in France only.
- The model SL-1700MK2 (XGB) is available in Belgium only.
- The model SL-1700MK2 (E), SL-1700MK2A (E), SL-1710MK2 (E) and SL-1710MK2A (E) are available in Scandinavia only.
- The model SL-1700MK2 (XA) and SL-1700MK2A (XA) are available in Asia, Latin America, Middle East and Africa only.
- The model SL-1700MK2 (XGE) is available in United Kingdom only.
- SL-1700MK2 and SL-1700MK2A are of silver finish.
- SL-1710MK2 and SL-1710MK2A are of black finish.

SL-1700MK2/
SL-1710MK2

SPECIFICATIONS (Specifications are subject to change without notice.)

General

Power supply:	~110-120/220 —240V, AC 50 or 60 Hz
Power consumption:	17.5W
Dimensions:	45.3 x 14.9 x 39.9 cm
(W x H x D)	(17-27/32" x 5-7/8" x 15-45/64")
Weight:	10 kg (22 lb.)

Turntable section

Type:	Quartz direct drive Automatic turntable Auto return Auto stop
Drive method:	Direct drive
Motor:	Brushless DC motor
Turntable platter:	Aluminum die-cast Diameter 33.2 cm (13-5/64") Weight 2 kg (4.4 lb.)
Turntable speeds:	33-1/3 rpm and 45 rpm
Pitch control:	±6% range
Starting torque:	1.5 kg-cm (1.3 lb-in)
Build-up characteristics:	0.7 sec. from standstill to 33-1/3 rpm
Braking system:	Electronic brake
Speed change due to load torque:	0% within 1.0 kg-cm (0.87 lb-in)
Wow and flutter:	0.01% WRMS* 0.025% WRMS (JIS C5521) ±0.035% peak (IEC 98A Weighted)

*This rating refers to turntable assembly alone, excluding effects of record, cartridge or tonearm, but including platter. Measured by obtaining signal from built-in frequency generator of motor assembly.

Rumble:	-56 dB (IEC 98A Unweighted) -78 dB (IEC 98A Weighted)
---------	--

Tonearm section

Type:	Universal
Effective length:	230 mm (9-1/16")
Arm height adjustment range:	

Overhang:	15 mm (19/32")
Effective mass:	12 g (without cartridge)
Tracking error angle:	Within 2°32' at the outer groove of 30 cm (12") record Within 0°32' at the inner groove of 30 cm (12") record
Offset angle:	22°
Friction:	Less than 7 mg (lateral, vertical)
Stylus pressure adjustment range:	0-2.5 g
Applicable cartridge weight range:	6-10 g 13.5-17.5 g (including headshell)
(with auxially weight):	9.5-13 g 17-20.5 g (including headshell)
(with shell weight):	3.5-6.5 g 11-14 g (including headshell)
Headshell weight:	7.5 g

Cartridge section

Model No.:	EPC-207C
Type:	Moving magnet
Frequency response:	20 Hz to 25 kHz 20 Hz to 15 kHz ±2 dB
Output voltage:	3 mV at 1 kHz 5 cm/s. zero to peak lateral velocity [8.5 mV at 1 kHz 10 cm/s. zero to peak 45° velocity (DIN 45500)]
Channel separation:	25 dB at 1 kHz
Channel balance:	Within 2 dB at 1 kHz
Compliance (dynamic):	10 x 10 ⁶ cm/dyne at 100 Hz
Stylus pressure:	1.75 ±0.25 g (17.5 ±2.5 mN)
Load impedance:	47 kΩ to 100 kΩ
Weight:	5.6 g (cartridge only)
Replacement stylus:	EPS-207ED (Elliptical stylus)

TECHNISCHE DATEN (Änderungen der technischen Daten vorbehalten.)

Allgemeine Daten

Stromversorgung: ~110-120/220-240 V, 50/60 Hz Wechselstrom
Leistungsaufnahme: 17,5 W
Abmessungen (B x H x T): 45,3 x 14,9 x 29,9 cm
Gewicht: 10 kg

Plattenspieler

Typ: Automatischer Plattenspieler
 Rückführautomatik
 Stopautomatik
 Manueller Betrieb
Antrieb: Direktantrieb
Motor: Kollektorloser Gleichstrommotor
Plattenteller: Aluminium-Spritzguß
 Durchmesser 33,2 cm
 Gewicht 2 kg
Plattenteller-Drehzahlen: 33-1/3 und 45 U/min
Drehzahl-Feinregulierung: ±6% Einstellbereich
Anlaufdrehmoment: 1,5 kg·cm
Drehzahl-Hochlaufzeit: 0,7 sec vom Stillstand auf 33-1/3 U/min
Bremssystem: Elektronische Bremse
Drehzahl-Abweichung aufgrund von Lastschwankungen: 0% innerhalb 1,0 kg·cm
Gleichlaufschwankungen: 0,01% WRMS*
 0,025% WRMS (JIS C5521)
 ±0,035% Spitze (IEC 98A bewertet)

*Diese Nennleistung bezieht sich auf das Laufwerk-Bauteil allein, ausschließlich Einflüsse von Schallplatte, Tonabnehmer oder Tonarm, aber einschließlich Plattenteller. Gemessen anhand von Signalen vom eingebauten Frequenzgenerator des Motorbauteils.

Rumpel-Geräuschspannungsabstand: -56 dB (IEC 98A unbewertet)
 -78 dB (IEC 98A bewertet)

Tonarm

Typ: Universal-Tonarm

Effektive Länge: 230 mm
Tonarmhöhe-Einstellbereich: Schraubteil: 6mm
Oberhang: 15 mm
Effektive Masse: 12 g (ohne Tonabnehmer)
Spurfehlwinkel: 2°32' bei der Einlaufrille einer 30 cm-Platte
 0°32' bei der Auslaufrille einer 30 cm-Platte
 22°
Kröpfungswinkel: 22°
Lagerreibung: Weniger als 7 mg (horizontal, vertikal)
Auflagekraft-Einstellbereich: 0-2,5 g
Zulässiger Tonabnehmer-Gewichtsbereich: 6-10 g
 13,5-17 g (einschließlich Tonarmkopf)
 9,5-13 g
 17-20,5 g (einschließlich Tonarmkopf)
(mit Ersatz-Gegengewicht):
Gewichtsbereich: 3,5-6,5 g
(mit Zusatzgewicht)
Tonarmkopf-Gewicht: 11-14 g (einschließlich Tonarmkopf)
 7,5 g

Tonabnehmer

Modell-Nummer: EPC-207C
Typ: Magnetischer Tonabnehmer
Frequenzgang: 20 Hz bis 25 kHz
 20 Hz bis 15 kHz ±2 dB
 3 mV bei 1 kHz
 5 cm/s. Null-zu-Spitze, Lateral
 [8,5 mV bei 1 kHz 10 cm/s. Null-zu-Spitze, 45° (DIN 45500)]
Ausgangsspannung:
Kanaltrennung: 25 dB bei 1 kHz
Kanalabweichung: Innerhalb 2 dB bei 1 kHz
Nachgiebigkeit (dynamisch): 10 x 10⁶ cm/dyn bei 100 Hz
Auflagekraft: 1,75 ± 0,25 g (17,5 ± 2,5 mN)
Impedanz: 47 kΩ bis 100 kΩ
Gewicht: 5,6 g (ohne Tonarmkopf)
Ersatznadel: EPS-207ED (Elliptische Nadel)

SPECIFICATIONS (Les spécifications sont susceptibles d'être modifiées sans préavis.)

Généralités

Alimentation: Alternatif 110-120/220-240V, 50 ou 60 Hz
Consommation: 17,5 W
Dimensions (L x H x P): 45,3 x 14,9 x 39,3 cm
Poids: 10 kg

Platine de lecture

Type: Platine automatique
 Retour automatique
 Arrêt automatique
Système d'entraînement: Entraînement direct
Moteur: Moteur C.C. sans balai
Plateau de lecture: Aluminium moulé sous pression
 Diamètre 33,2 cm
 Poids 2 kg
Vitesses de rotation: 33-1/3 et 45 t/p.m
Réglage d'écart: Plage de réglage de ±6%
Couple de démarrage: 1,5 kg·cm
Caractéristiques d'augmentation: 0,7 sec. de l'arrêt à 33-1/3 t/p.m.
Système de freinage: Frein électronique
Variation de vitesse due au couple de charge: 0% en deçà de 1,9 kg·cm
Plourage et scintillement: 0,01% de valeur efficace*
 0,025% de valeur efficace (JIS C5521)
 ±0,035% de crête (IEC 98A Pondéré)

*Ce régime nominal se rapporte à l'ensemble du tournedisque seul, excluant les effets du disque, de la cellule pick-up ou de bras de lecture, mais comprenant le plateau. Mesuré par l'obtention d'un signal provenant du générateur de fréquences incorporé de l'ensemble du moteur.

Ronflement: -56 dB (IEC 98A Non pondéré)
 -78 dB (IEC 98A Pondéré)

Bras de lecture

Type: Bras de lecture universel
Longueur effective: 230 mm
Portée du réglage de la hauteur du bras: Partie hélicoïdale 6 mm

Porte-à-faux: 15 mm
Masse réelle: 12 g (sans la cellule pick-up)
Angle d'erreur de piste: En deçà de 2°32' au sillon extérieur d'un disque de 30 cm
 En deçà de 0°32' au sillon intérieur d'un disque de 30 cm
 22°
Angle de décalage: 22°
Frottement: Moins de 7 mg (latéral et vertical)
Plage de réglage de la pression d'appui: 0-2,5 g
Gamme du poids de la cellule pick-up utilisable: 6-10 g
 13,5-17 g (y compris la coque porte-cellule)
 9,5-13 g
 17-20,5 g (y compris la coque porte-cellule)
 3,5-6,5 g
 11-14 g (y compris la coque porte-cellule)
Poids de la cellule: 7,5 g

Cellule pick-up

No. du modèle: EPC-207C
Type: Aimant mobile
Réponse en fréquence: 20 Hz à 25 kHz
 20 Hz à 15 kHz ±2 dB
 3 mV à 1 kHz; 5 cm/s. zéro à vitesse latérale de crête
 (8,5 mV à 1 kHz 10 cm/s., zéro à vitesse 45° de crête [DIN 45500])
Tension de sortie: 25 dB à 1 kHz
 En deçà de 2 dB à 1 kHz
Séparation de canal: 25 dB à 1 kHz
Equilibrage des canaux: En deçà de 2 dB à 1 kHz
Elasticité (dynamique): 10 x 10⁶ cm/dyne à 100 Hz
Pression de la pointe de lecture: 1,75 ± 0,25 g (17,5 ± 2,5 mN)
Impédance de charge: 47 kΩ to 100 kΩ
Poids: 5,6 grammes (cellule seule)
Pointe de lecture de remplacement: EPS-207ED (Forme elliptique)

■ CONTENTS

LOCATION OF CONTROLS.....	3~4	CONTROL CIRCUIT BOARD	21,22
TECHNICAL GUIDE.....	4~6	DRIVE CIRCUIT BOARD	23
TROUBLE SHOOTING OF ARM DRIVE CIRCUIT.....	7	SCHEMATIC DIAGRAM 1 (Control Circuit Board)	24~26
DISASSEMBLY PROCEDURE	7~11	SCHEMATIC DIAGRAM 2 (Drive Circuit Board)	27,28
ADJUSTMENTS (Electrical)	11~12	TONE ARM DRIVE CIRCUIT BOARD	29,30
ADJUSTMENT POINTS.....	12	SCHEMATIC DIAGRAM 3 (Tone arm Drive Circuit Board)	31
REGLAGES (Electricité)	13	REPLACEMENT PARTS LIST (Electric Parts)	32
ABGLEICHUNG (Elektrisch)	14	EXPLODED VIEW (Main Base).....	33,34
ADJUSTMENTS (Tone arm)	15	REPLACEMENT PARTS LIST (Main Base and Bottom Base Parts)	35
REGLAGES (Bras acoustique)	16	EXPLODED VIEW (Bottom Base).....	36,37
JUSTIERUNG (Tonarm)	17	EXPLODED VIEW (Tone Arm and Arm Base)	38,39
BLOCK DIAGRAM (Drive Circuit)	18	REPLACEMENT PARTS LIST (Tone Arm and Arm Base Parts)	40
BLOCK DIAGRAM (Control Circuit, Arm Control Circuit and Pitch Control Circuit)	19		
REFERENCE VOLTAGE AND WAVEFORM AT EACH IC ...	20		

■ LOCATION OF CONTROLS

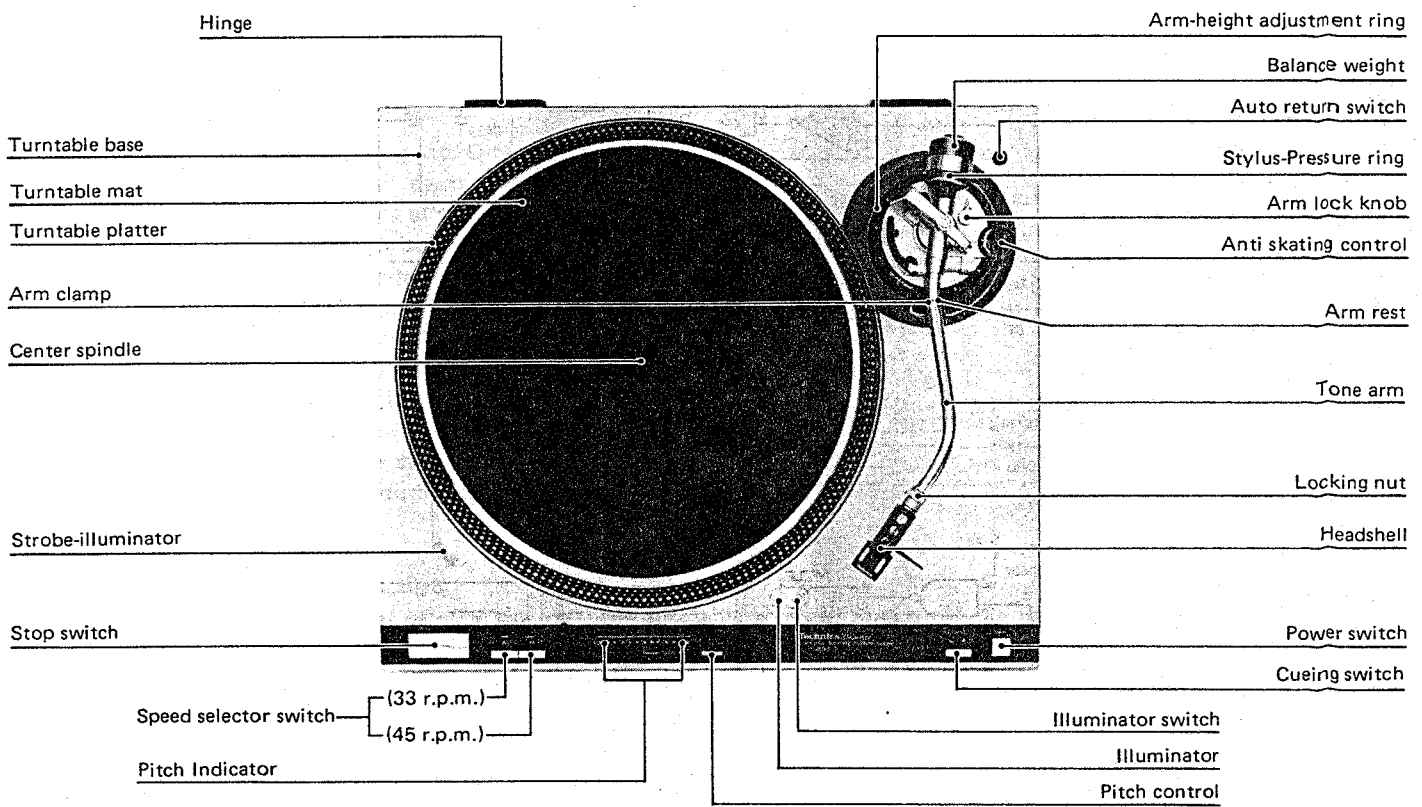

SL-1700MK2/ SL-1710MK2

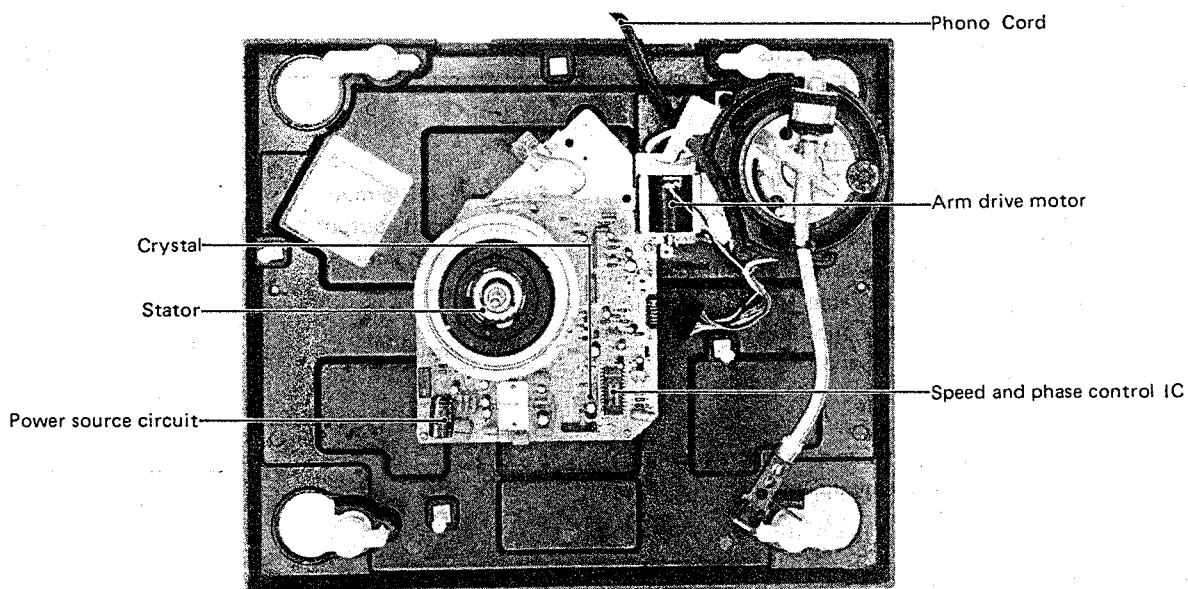
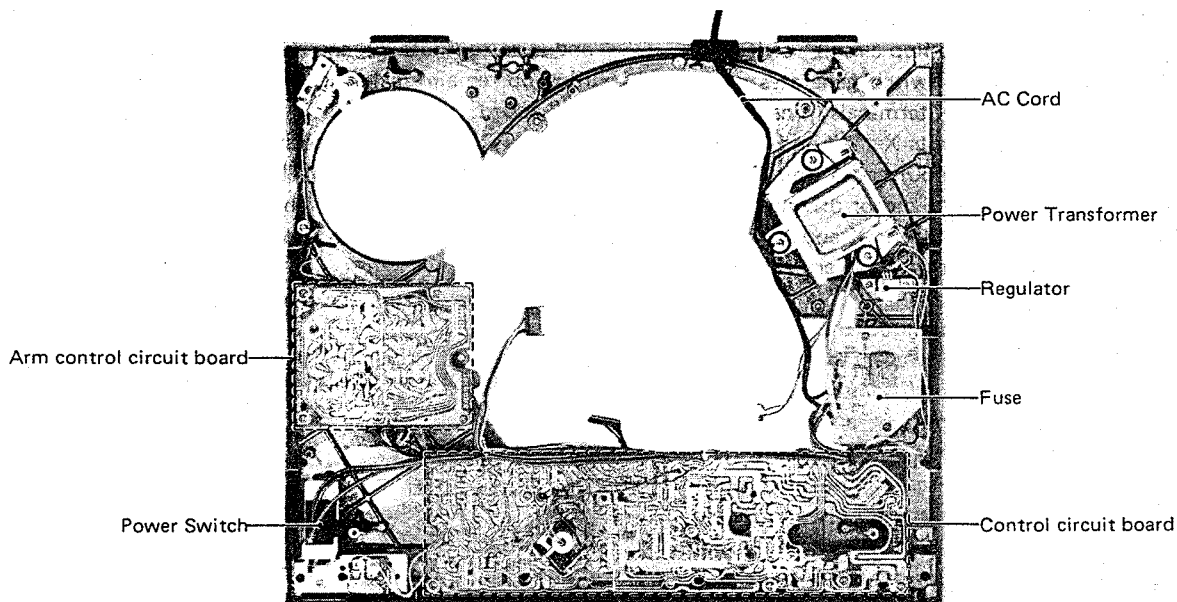

■ TECHNICAL GUIDE

Arm control circuit

This circuit includes a circuit to control the cueing and returning operation of the arm by using a DC motor, a rest detection circuit which gives a start/stop instruction to the turntable, and a circuit to electrically detect the return position the same as in SL-1300MK2.

1. Cueing operation

Arm switches A and B are turned ON and OFF by the cam interlocked with the cueing mechanism of the arm. Whether the arm is cued up or down with the cueing switch depressed depends on the positions of these two switches.

● Cueing down

When the arm switch A is OFF, while B is ON or OFF, depressing the cueing switch results in cueing down.

As the arm switch A is OFF, A is "H" and B is "L". The output of B is applied to D terminals (pin 5 and 9 of IC460) of the D flip-flop circuit* of IC460. Then, depressing the cueing switch generates clock pulses which are applied to CK terminals (pins 3 and 11) of IC460, thus the outputs X="L" and Y="H" come out of X (pin 1 of IC460) and Y (pin 12 of IC460). The outputs enter the motor driving circuit to operate the DC motor. Outputs X and Y, motor rotating direction, and arm operation are shown in the Fig. 1.

With the above operations completed, the arm is cued down by the drive motor. However, the motor will continue rotating if the conditions are left unchanged. Therefore, the outputs of arm switches A and B pass through the Exclusive-OR circuit* and generate motor stopping pulses at the next pulse generating circuit in order to apply pulses to S (pin 6 of IC460) and R (pin 10 of IC460) terminals of the flip-flop circuit of IC460 to reset the outputs at X and Y (X="H", Y="L", thus stopping the rotation of the motor.

• Cueing up

When the arm switch A is ON, while B is ON or OFF, depressing the cueing switch results in cueing up. As the arm switch A is ON, A is "L" and B is "H".

The output of B is put into D terminals (pins 5 and 9) of IC460. Then, depressing the cueing switch generates clock pulses as in cueing down operation, causing X and Y to become "H" and "L" respectively. Thus, the motor rotates in the direction of cueing up operation as shown in Table 1. After that, reset pulses are applied to the flip-flop circuit of IC460, then outputs at both X and Y become "H" causing the motor to stop.

Note:

Cueing up is possible during cueing down, but cueing down is not possible during cueing up.

2. Rest position detection

When the arm moves off the rest, the turntable rotates. Structurally, a coupler using an LED and photo-transistor is located under the arm base; when the arm is on the rest, the LED and photo-transistor are interrupted by the slit, turning the photo-transistor (PH402) off; when the arm is off the rest, the photo-transistor turns on, causing C to become "L", then Q455 turns off and a voltage is applied to pin 19 of IC201 to rotate the turntable. Input "L" is applied to pin 9 of IC456 in order to inhibit the operation of the gate so that depressing the stop switch does not cause the arm to operate when the arm is on the rest.

3. Stop operation

If desired to stop the performance, push the stop switch, then the arm returns to the arm rest.

Depressing the stop switch generates \square pulse at D .

D is "L" when the arm is on the rest, inhibiting the pulse from the stop switch, and it is "H" when the arm is off the rest.

Depressing the stop switch, when D is "H", generates \square pulse at E . The pulse causes the R-S flip-flop circuit of IC457 and IC458 to reverse, then E and F respectively becomes "H" and "L", while S (pin 8 of IC460) and S (pin 6 of IC460) terminals of D flip-flop circuit of IC460 become "H" resulting in X="H" and Y="L". The output causes the arm to return. Also, about 0.9 sec. after rest position detection to stop the turntable, \square pulse is applied to D of R-S flip-flop circuit of IC457 and IC458, thus resetting the R-S flip-flop (E ="L", F ="L").

* D flip-flop circuit

This circuit includes a D input, a clock input (ck), and two outputs Q and \bar{Q} . The outputs of this flip-flop remain unchanged even with D input "L" or "H" added.

However, if a clock pulse is applied to this circuit while it is supplied with a D input, the D input is transmitted to output Q. Therefore, output Q causes the circuit operation to delay by clock pulse equivalence.

The flip-flop circuit and the truth table are shown below.

a) Circuit

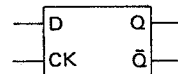

b) Truth table

tu		tu+1
D	Qu	Qu+1
L	L	L
L	H	L
H	L	H
H	H	H

Output X	Output Y	Rotating direction	Arm Operation
H	H	Stop	Stop
H	L	Reverse	Cueing up, return
L	H	Normal	Cueing down

[Fig. 1]

* Exclusive-OR circuit

In this circuit, output Y is "H" only when outputs A and B are not equal.

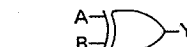

a) Logic circuit

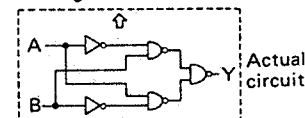

Input		Output
A	B	Y
L	L	L
L	H	H
H	L	H
H	H	L

b) Truth table

When the ① is H pressing the stop switch causes the arm to start returning irrespective of its position. When the arm is in return operation, the cueing switch does not work because of priority given to the stop operation.

4. Auto return operation

The detection of record end is performed with the optical sensor output, same as in SL-1300MK2; then the arm is returned in the same way as in the above-mentioned stop operation.

If the arm is in up position (arm switch A is OFF), no pulse is generated at ② for end detection, therefore auto return operation can not be achieved by shifting the arm.

* R-S flip-flop circuit

This circuit includes two inputs S(set), R(Reset), and two outputs Q and \bar{Q} . If S="H", R="L", then Q="L". If S="L", R="H", then Q="H". After determination of the output, changing the input to "H" does not cause the output to change.

a) Circuit

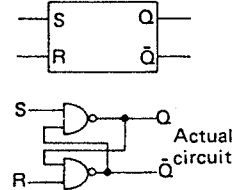

b) Truth table

S	R	Q _{n+1}
L	L	H
L	H	H
H	L	L
H	H	Q _n

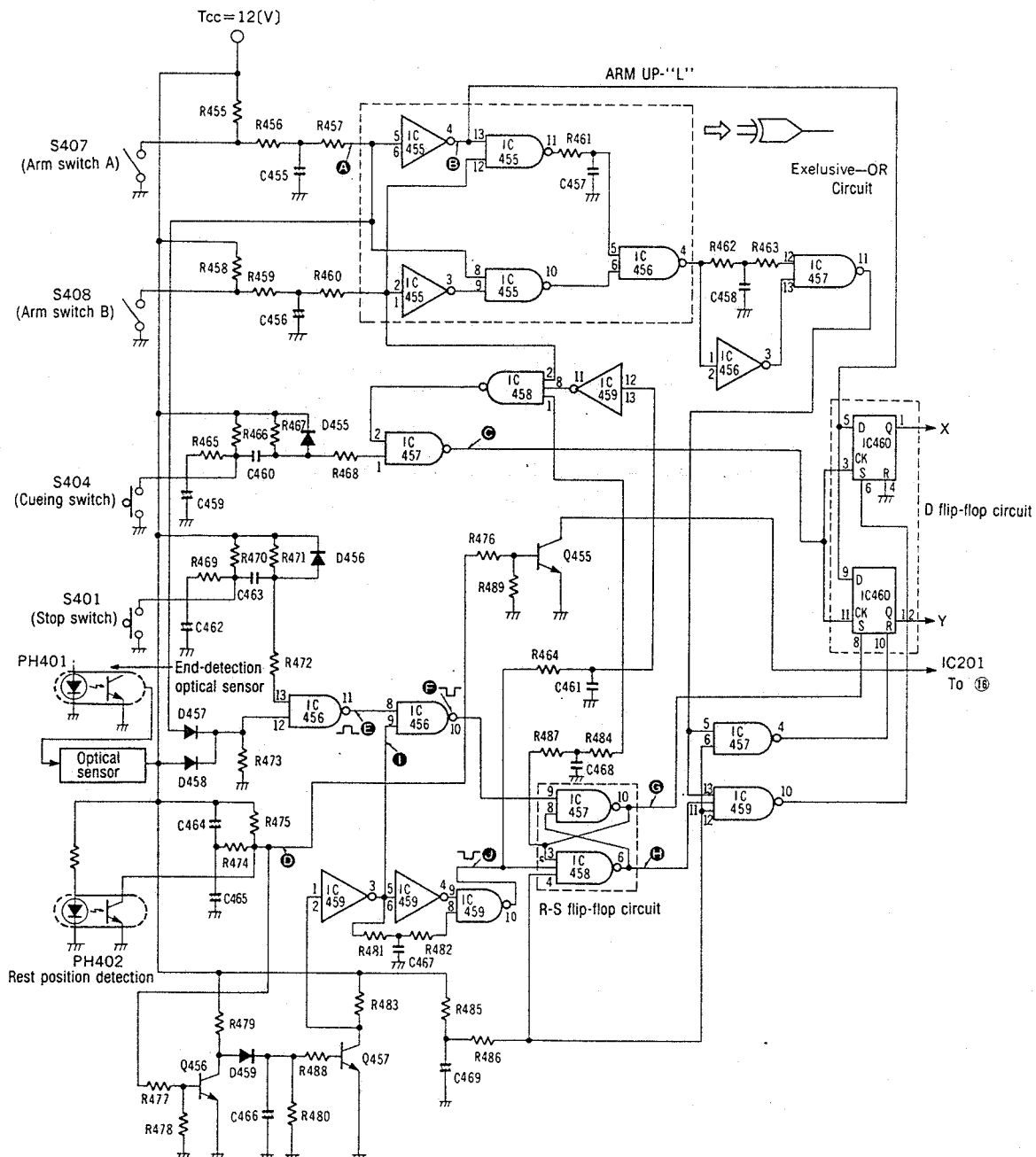

■ TROUBLE SHOOTING OF ARM DRIVE CIRCUIT

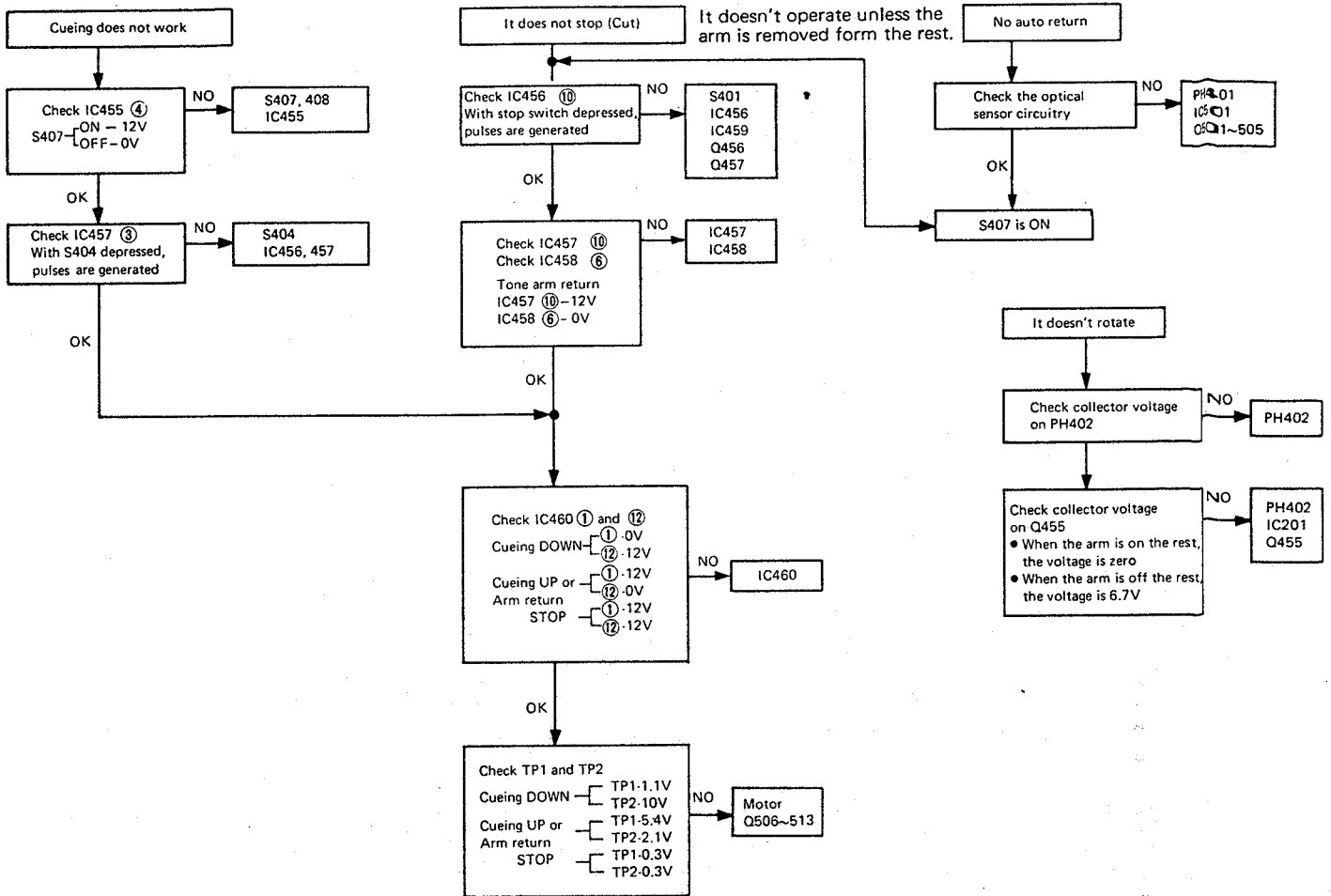

■ DISASSEMBLY PROCEDURE

How to remove main base ass'y and bottom base ass'y

1. Clamp tone arm to the arm rest.
2. Remove head shell and turntable platter.
3. Close dust cover.
4. Turn unit upside down taking special care not to damage or scratch the dust cover.
5. Remove 6 screws **A** of the audio insulator and 2 screws **E** of the phono cord clasper as shown in Photo 1.
6. Holding the player firmly with both hands, to prevent separation of upper section (bottom base ass'y) from lower section (main base ass'y), turn it carefully upwards.
7. Remove dust cover.
8. Remove 5 screws **C** of the panel cover as shown in Photo 2.
9. Remove 3 connectors **D** and 2 read wires **B** from power transformer as shown in Photo 3.
10. To remove the main base ass'y from the bottom base ass'y, turn cueing lever upward and move tone arm towards center of spindle. The main base ass'y can be lifted up easily. (See Photo 4).

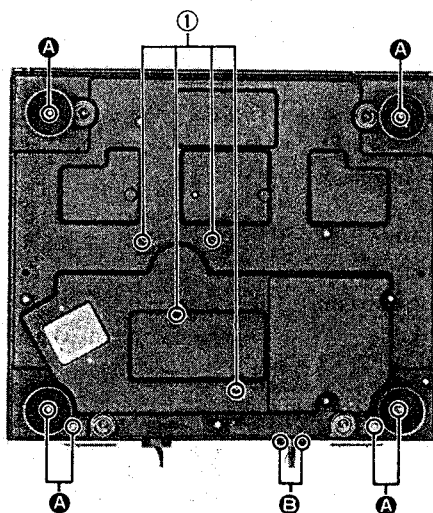

[Photo 1]

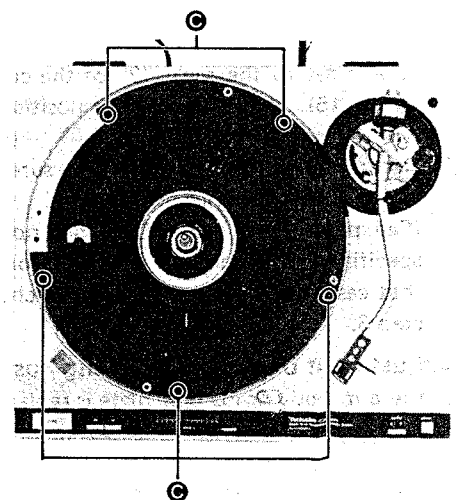

[Photo 2]

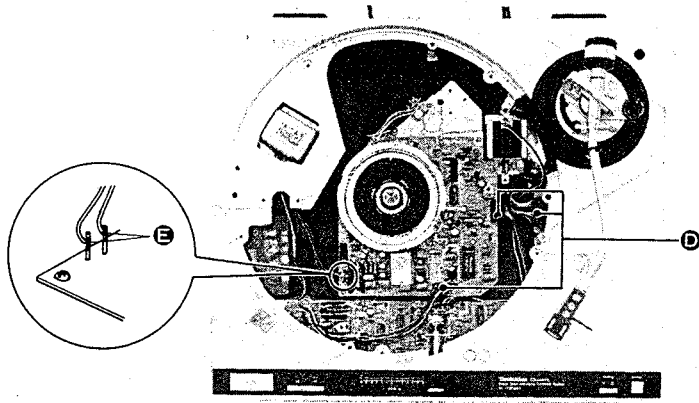

[Photo 3]

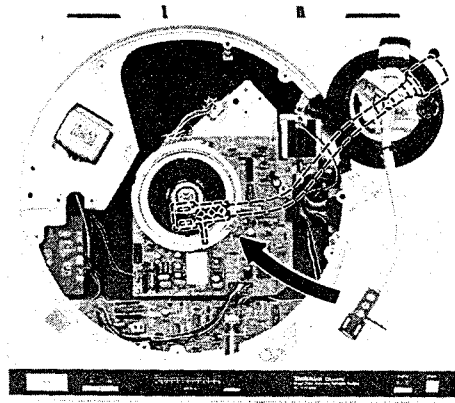

[Photo 4]

How to remove drive circuit p.c.b. and stater frame coil

1. Remove main base ass'y and bottom base ass'y.
2. Remove 3 screws ⑦ of the drive circuit p.c.b. and 3 screws ⑥ of the stater frame cover as shown in Photo 5.
3. Disconnect 18 soldered parts ④ of the stater frame coil and 4 soldered parts ⑤ of the F.G detector coil as shown in Fig. 2.
4. Remove 3 screws ① of the stater frame ass'y as shown in Fig. 2.

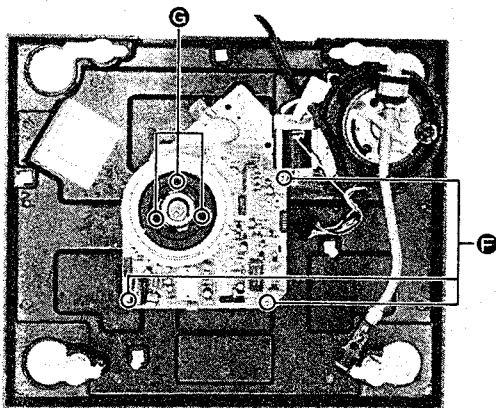

[Photo 5]

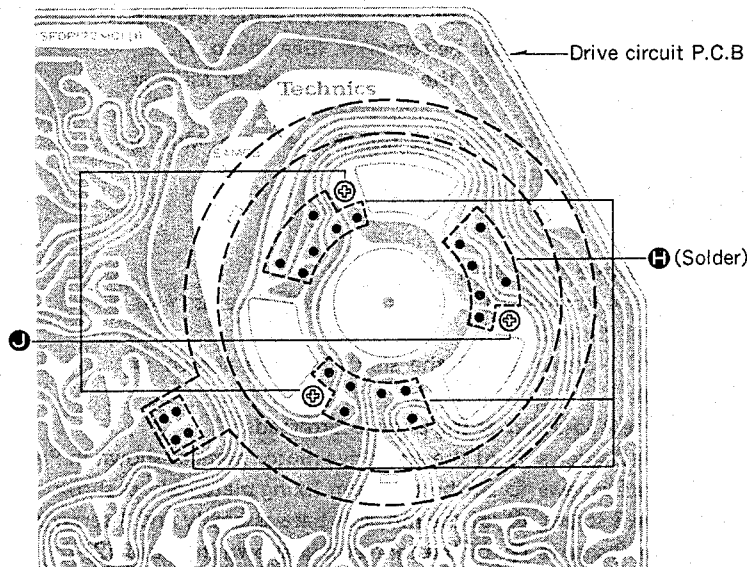

[Fig. 2]

How to remove control circuit p.c.b. and stylus-illuminator lamp

1. Remove main base ass'y and bottom base ass'y.
2. Remove 10 screws ⑩ of the control circuit p.c.b. as shown in Fig. 3.
3. Remove 2 screws ① of the power switch bracket as shown in Fig. 3.
4. Set up the control circuit board as shown in Fig. 4. Then remove the 2 screws ① of the stylus illuminator mounting plate. (Fig. 4).
5. To replace the stylus illuminating lamp, remove the setscrew of the lamp case (Fig. 5) and detach the lamp case, then the stylus illuminating lamp can be replaced.

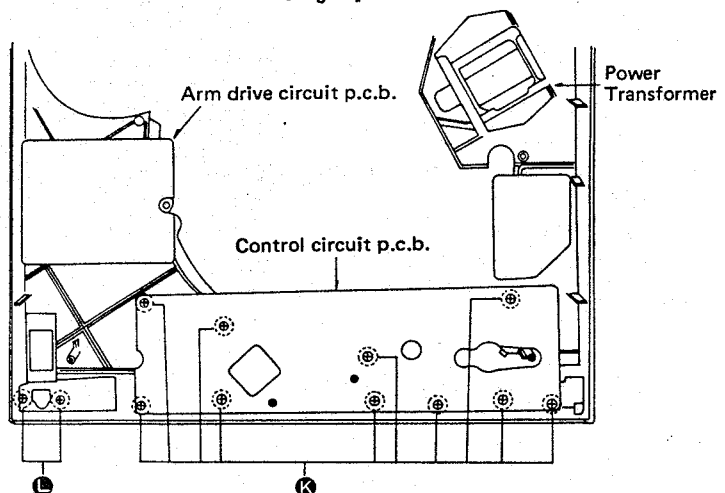

[Fig. 3]

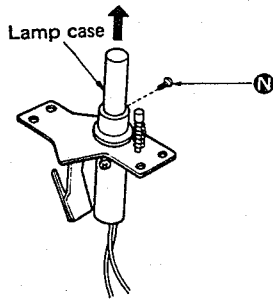

[Fig. 5]

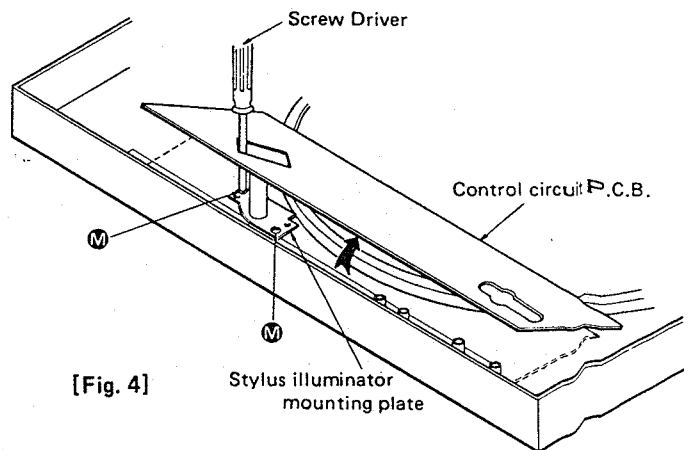

[Fig. 4]

How to remove arm drive motor

1. Remove head shell and turntable platter.
2. Clamp tone arm to the arm rest.
3. Remove 5 screws **C** of the panel cover as shown in Photo 2.
4. Remove arm drive belt.
5. Turn the muting switch adjusting screw so that the arm drive motor setscrew can be removed. (See Photo. 7).
6. Remove 1 screw **P** of the arm drive motor ass'y as shown in Photo 7.
7. When adjusting the muting switch, refer to Muting Switch Adjustment.

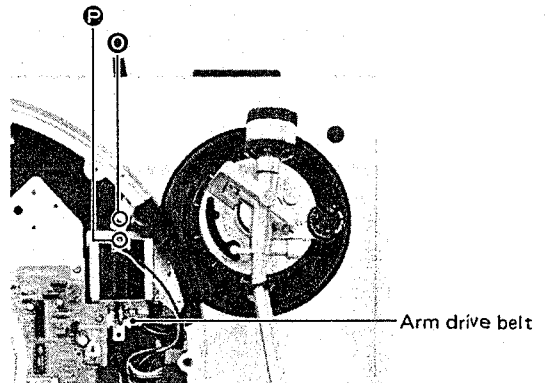

[Photo 7]

How to remove tone arm

1. Remove 4 screws **C** of the tone arm base ass'y as shown in Photo 8.
2. Remove 1 screw **R** of the shilde plate as shown in Photo 9.
3. Disconnect soldered of the phono cord reads.
4. Remove 2 screws **S** of the arm drive motor plate as shown in Photo 9.
5. Remove 2 screws **T** of the tone arm fixing plate ass'y as shown in Photo 10.
6. Remove 3 screws **U** of the movable base assembly and 1 screw **V** of the ground wire as shown in Photo 11.
7. Remove 2 screws **W** of the tone arm as shown in Photo 12.
8. To remove the pick-up base plate, remove the arm lift height adjusting screw and the arm lift.
9. Remove 1 screws **X** and 1 circlip **Y** of the position fix plate as shown in Photo 12.
10. Remove 2 screws **Z** of the pick-up base plate as shown in Photo 12.

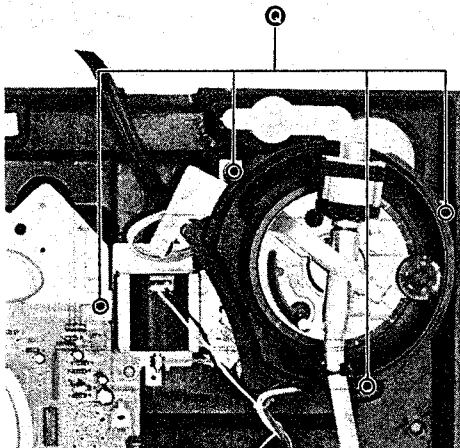

[Photo 8]

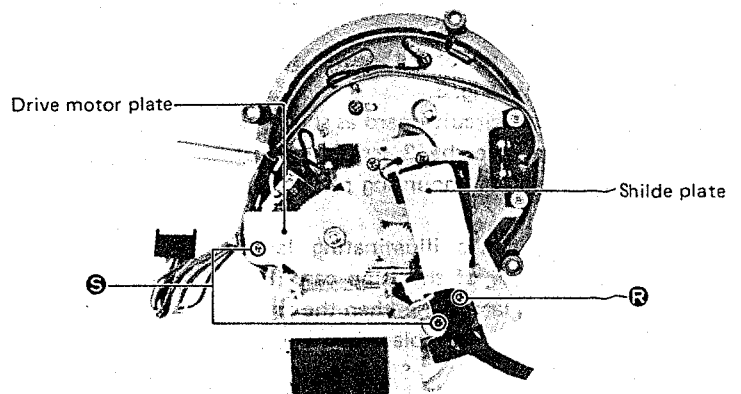

[Photo 9]

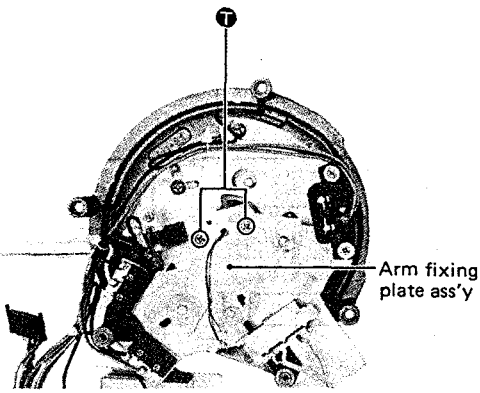

[Photo 10]

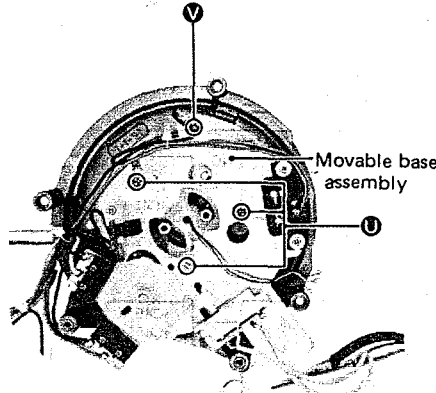

[Photo 11]

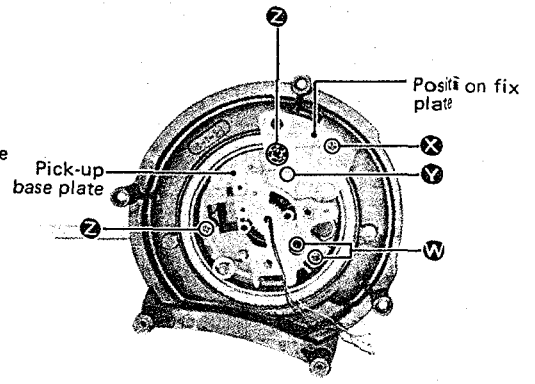

[Photo 12]

Arm Base Assembling Procedure

1. Attach the control ring to the arm base seat.
(The control ring should be rotated counterclockwise.)
 2. Completely tighten the control ring, and then loosen it 1.5 ~ 2.5 turns to set the scale to "3". (See photo 13.)
 3. Hold the arm base and set the red line mark on the arm base to the scale near "2", then turn the arm base clockwise. (See photo 14.)
- Note) Take care not to allow deflection of the predetermined positions of the control ring and arm base seat.

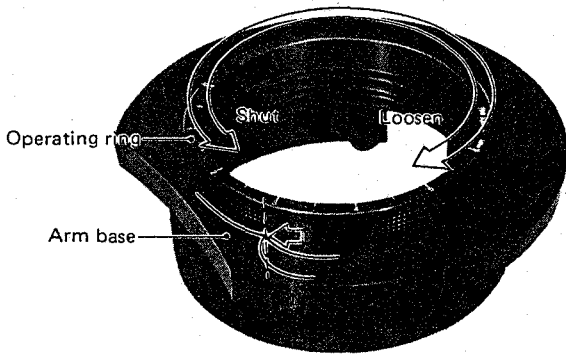

[Photo 13]

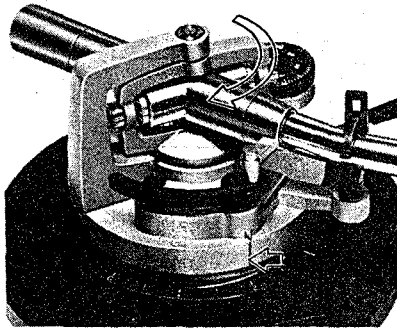

[Photo 14]

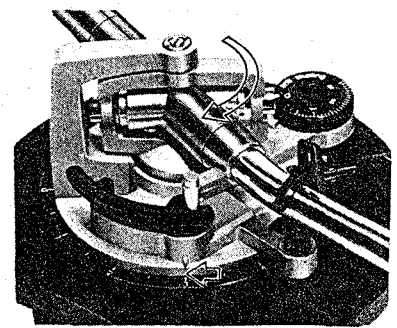

[Photo 15]

4. Adjust the arm base so that the red line mark on the arm base is set to the scale "3" of the control ring. (See photo 15). Next, secure the position fix plate with two setscrews. (See photo 12.)
5. Rotate the control ring and make sure that the arm base shifts within the range of 0 ~ 6mm. (See photo 16 A, B.) If it does not shift within the specified range, the arm base position is deflected. In that case, disassemble the parts and check as specified in step 3.

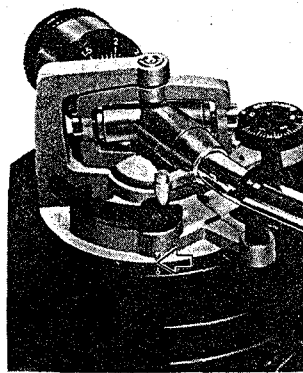

(A)

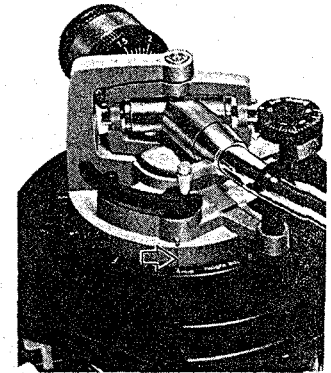

(B)

Adjustment of Cancellor Spring Position

If the arm body or PU base plate is replaced, be sure to set the canceller knob to "0.5" and make sure that the canceller spring is in contact with the arm shaft. (See photo 17.)

If the canceller spring is deflected, adjust it as follows:

1. Clamp the arm on the rest.
2. Set the canceller knob to "0.5".
3. Remove the PU base plate, adjust gear A so that the canceller spring is in the position of photo 17.
4. Mount the PU base plate onto the arm base and check the spring position.

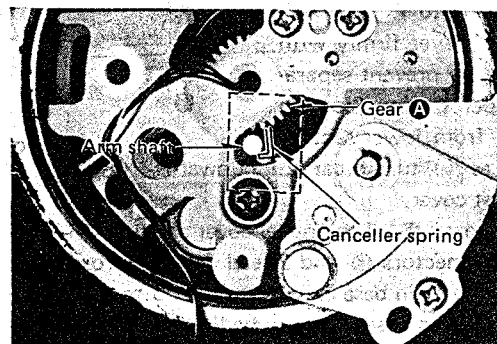

[Photo 17]

How to install the drive circuit board assembly

The circuit board assembly can be detached by removing the 4 setscrews ① shown in Photo. 1. When installing it onto the bottom base assembly after adjustment and repair, follow the procedure mentioned below.

1. Temporarily tighten the 4 setscrews ①.
(Refer to Photo 1.)
2. Adjust so that the center spindle is aligned to the center of the turntable provided with equal clearances ② as in Fig. 11.
3. Completely tighten the 4 setscrews ①, taking care not to allow deflection of the center spindle.

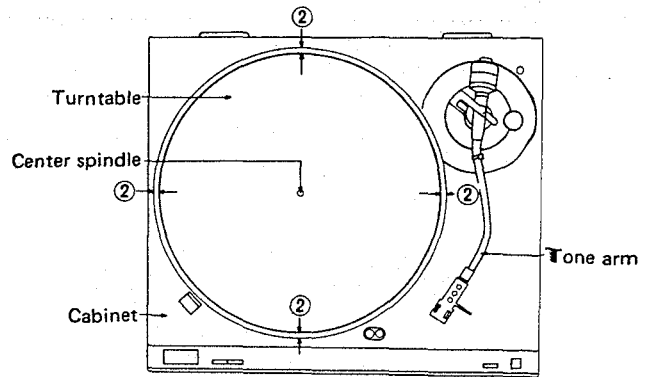

[Fig. 6]

■ ADJUSTMENTS (Electrical)

- Notes:
- Make the following adjustments after replacing parts such as IC's, transistors, diodes, etc.
 - Condition of the set
 1. Power switchON
 2. Pitch controlCenter position
 3. Speed selector switch33 r.p.m.
 - Instruments to be used
 1. Oscilloscope
 2. Frequency counter

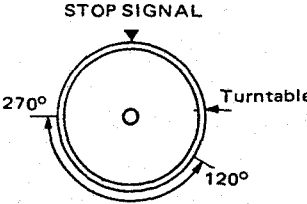
	Adjustment	connection Points	Adjustment Points	Adjustment Method
A	Adjustment of pitch control $\pm 0\%$ (PITCH)	Frequency counter + \rightarrow TP27 - \rightarrow GROUND	VR301	<ol style="list-style-type: none"> 1. Pitch control switch to center position. 2. Adjust VR301 for 262.08 kHz ± 0.05 kHz of frequency.
B	Adjustment of pitch control LED (GAIN)	Frequency counter + \rightarrow TP27 - \rightarrow GROUND	VR425	<ol style="list-style-type: none"> 1. Adjust pitch control switch for 269.94 kHz of frequency. 2. Adjust VR425 so that the LED (pitch indicator plus 3%) lights up.
C	Braking adjustment (BRAKE)	—	VR201	 <p>Adjust VR201 for complete stop within $120^\circ \sim 270^\circ$ after stop signal initiated. (turntable becomes free a few seconds after stop.)</p>

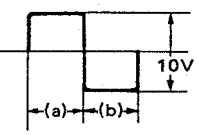
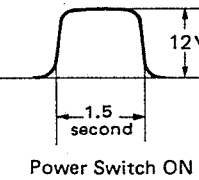
D	Optical sensor gain adjustment (GAIN)	Oscilloscope + → TP32 - → GROUND	VR501	<p>TP32 waveform</p> 	<p>With arm near center spindle, manually move with uniform motion, and adjust VR501 as that the (a) and (b) pitch of the waveform of TP32 is equal.</p>
E	Auto-Return time adjustment (TIME)	Oscilloscope + → TP38 - → GROUND	VR502	<p>TP38 waveform</p> 	<p>Turn power switch on, and adjust VR502 so that the time (T₀) from power on until the voltage of TP38 inverts is 1.5 second at 33 r.p.m. (1.1 second at 45 r.p.m.)</p>

■ ADJUSTMENT POINTS

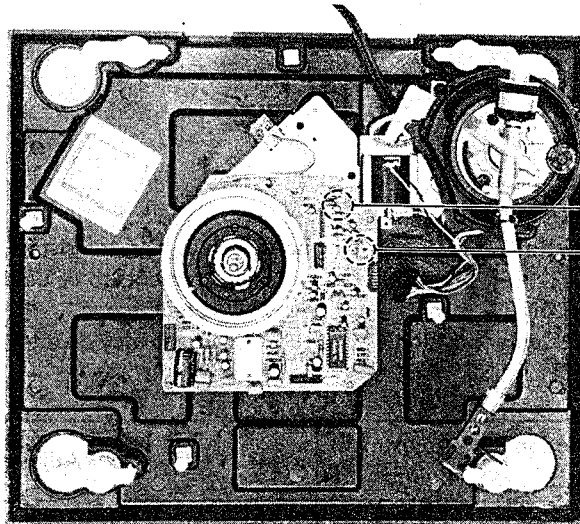

VR301 Adjustment of pitch control $\pm 0\%$
VR201 Braking adjustment

Auto-return time adjustment VR502
Optical sensor gain adjustment VR501
Adjustment of pitch control LED VR425

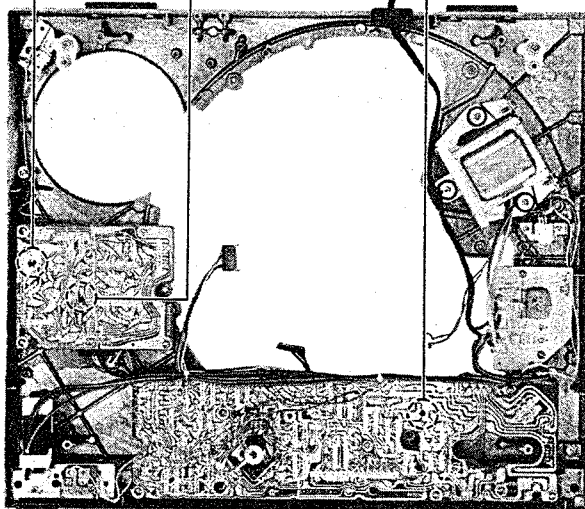

■ **REGLAGES (Electricité)**

- Notes:
- Effectuer les réglages suivants après avoir remplacé des éléments tels que les C.I., transistors, diodes, et autres.
 - Etat de l'appareil
 - 1. Commutateur d'alimentation Marche
 - 2. Commande d'alignement de la vitesse Position centrale
 - 3. Commutateur de sélecteur de vitesse 33-1/3 trs/mn
 - Appareils à utiliser
 - 1. Oscilloscope
 - 2. Fréquencemètre

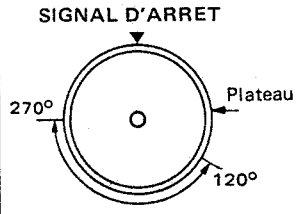
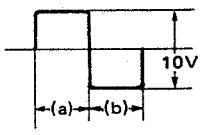
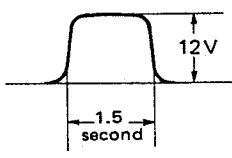
	Réglage	Points de connexion	Points de réglage	Méthode de réglage
A	Réglage de la commande d'alignement de la vitesse, ±0% (PITCH)	Fréquencemètre + → TR27 - → TERE E	VR301	1. Commutateur de commande d'alignement de la vitesse en position centrale. 2. Régler la VR301 sur une fréquence de 262,08 kHz ±0,05 kHz.
B	Réglage la LED de la commande d'alignement de la vitesse (GAIN)	Fréquencemètre + → TP27 - → TERE E	VR425	1. Régler la commutateur de commande d'alignement de la vitesse sur la fréquence de 269,94 kHz. 2. Régler la VR425 de telle sorte que LED (plus 3% du témoin d'alignement de la vitesse) s'allume.
C	Réglage du feïn (BRAKE)	—	VR201	 <p>Régler la VR201 sur l'arrêt complet entre 120° et 270° après la début de l'envoi du signal d'arrêt. (Le plateau devient libre quelques secondes après l'arrêt.)</p>
D	Réglage du Senseur optique (GAIN)	Oscilloscope + → TP32 - → TERE E	VR501	<p>Forme d'onde du TP32</p>  <p>Quand le bras est proche du mandrin central, le déplacer à la main dans un mouvement uniforme et régler la VR501 de telle sorte que les longueurs (a) et (b) de la forme d'onde du TP32, soient égales.</p>
E	Réglage du temps de retour automatique (TIME)	Oscilloscope + → TP38 - → TERE E	VR502	<p>Forme d'onde du TP38</p>  <p>Allumer la commutateur d'alimentation et régler la VR502 de telle sorte que la temps (To) écoulé entre l'allumage de l'alimentation et l'inversion de la tension du TP38, soit d'une seconde et demie à 33 tours. (1,1 seconde à 45 tours)</p> <p>Commutateur d'alimentation allumé</p>

■ **ABGLEICHUNG (Elektrisch)**

- Anmerkung:
- Nach Teilerneuerung von z.B. IC, Transistor, Diode usw, die folgenden Abgleichungen vornehmen.
 - Einstellung des Gerätes
 1. Netzschalter ON
 2. Tonhöhekontrolle Mittlers Stellung
 3. Drehzahlwähler 33 U/min.
 - Zu verwendende Instrumente
 1. Oszilloskop
 2. Signalfrequenzmesser

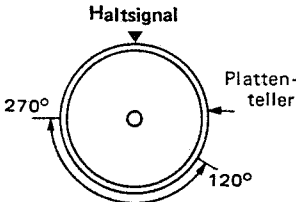
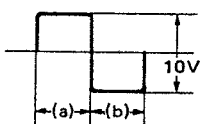
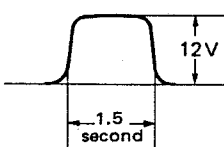
	Abgleichung	Anschlußpunkte	Abgleichpunkte	Abgleichmethode
A	Abgleich der Tonhöhekontrolle $\pm 0\%$ (PITCH)	Signalfrequenzmesser + \rightarrow TP27 - \rightarrow GROUND	VR301	<ol style="list-style-type: none"> 1. Schalter für Tonhöhekontrolle auf Mittelstellung. 2. VR301 auf 262.08 kHz $\pm 0,05$ kHz abgleichen.
B	Abgleich der Tonhöhekontrolle LED (GAIN)	Signalfrequenzmesser + \rightarrow TP27 - \rightarrow GROUND	VR425	<ol style="list-style-type: none"> 1. Schalter für Tonhöhekontrolle auf 269,94 kHz abgleichen. 2. VR425 so abgleichen, daß LED (Tonhöheanzeige plus 3%) auf leuchtet.
C	Bremsenjustierung (BRAKE)	—	VR201	 <p>VR201 innerhalb 120 - 270° nach Haltsignalanzeige auf kompletten Halt justieren. (Plattenteller wird ein paar Sekunden nach Halt frei.)</p>
D	Abgleich des optischen Sensorgewinns (GAIN)	Oszilloskop + \rightarrow TP32 - \rightarrow GROUND	VR501	<p>TP32 Wellenform</p>  <p>Den Arm in die Nähe der Mittelspindel legen, manuell mit gleichmäßiger Bewegung schieben und VR501 so abgleichen, daß die (a) und (b) Tonhöhe der Wellenform TP32 gleich sind.</p>
E	Zeitabgleich der Auto-Rückstellung (TIME)	Oszilloskop + \rightarrow TP38 - \rightarrow GROUND	VR502	<p>TP38 Wellenform</p>  <p>Netzschalter einschalten und VR502 so abgleichen, daß die Zeit (T_0) von Einschalten bis zur Umkehrung der Spannung von TP38 bei 33 U/min. 1,5 Sekunden beträgt.</p>

■ ADJUSTMENTS (Tone arm)

● Adjustment for automatic return position

1. Keep the power switch turned OFF to prevent the turntable from rotation.
2. Remove the rubber cap.
3. Move the tone arm toward the center spindle side, and make the adjustment by gradually turning the adjusting screw.

In case where the tone arm tends to return before the playing has finished.

—Move counterclockwise. (See Photo 18 A)

In cases where the tone arm fails to return after the last groove of the record.

—Move clockwise. (See Photo 18 B)

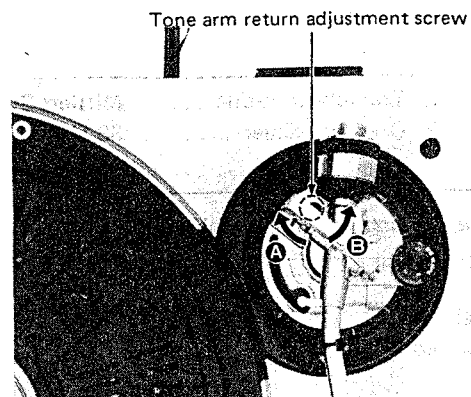

[Phot 18]

Adjustment of arm-lift height (See Photos 19 and 20.)

The arm-lift height (distance between the stylus tip and record surface when cueing lever is at the up position) has been adjusted at the factory before shipment to approximately 5 to 10 mm.

For using different cartridges available on the market or when further adjustments are particularly necessary, make adjustment as follows:

1. Move the tone arm toward the center spindle.
Attach the stylus protector, if available, to guard the stylus tip from damage.
2. Turn the adjustment screw clockwise or counterclockwise, while pushing the arm lift down.

Clockwise rotation

—distance between the record and stylus tip is reduced.

Counterclockwise rotation

—distance between the record and stylus tip is increased.

Note:

As the adjusting screw has a hexagonal head, be sure to make the adjustment while depressing the arm lift, or the screw will not move freely.

Also be sure that the hexagonal head retracts correctly into the arm lift when the latter is released.

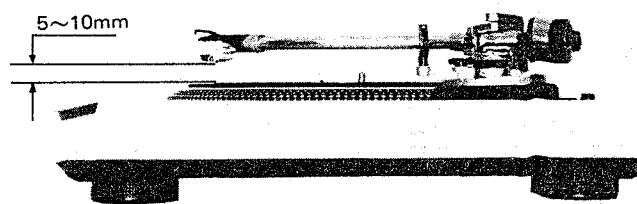

[Photo 19]

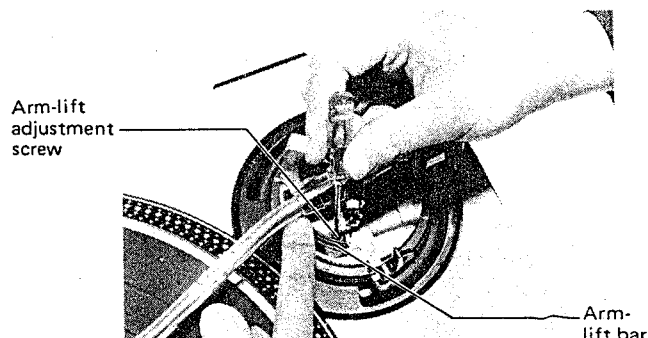

[Photo 20]

● Muting adjustment

This unit employs a muting switch to eliminate noise created when the stylus is placed on or moved off the record disk. If the sound is not heard immediately or noise is created when the stylus is shifted down onto the disk, adjust it by turning the muting adjust screw. (Photo 21).

Muting time adjustment screw

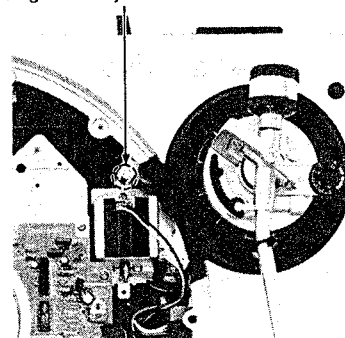

[Photo 21]

■ REGLAGES (Bras acoustique)

● Réglage de la position de retour automatique

1. Conserver le commutateur d'alimentation coupé pour éviter que la platine ne tourne.
2. Enlever le tapis de caoutchouc.
3. Porter le bras acoustique vers le côté du mandrin central et effectuer le réglage en tournant progressivement la vis de réglage.

Si le bras acoustique tend à revenir avant la fin de la lecture du disque:

— Déplacer à gauche (voir la photographie 18 A)

Si le bras acoustique ne revient pas après le dernier sillon du disque:

— Déplacer à droite (voir la photographie 18 B)

Réglage du poids du lève-bras (Voir photographies 19 et 20)

Le poids du lève-bras (distance entre la pointe de l'aiguille et la surface du disque lorsque le levier de mise en pile est dans la position levée) a été réglé en usine avant l'expédition, à environ 5 à 10mm.

Lors de l'utilisation de cellules différentes disponibles sur le marché ou quand des réglages ultérieurs sont particulièrement nécessaires, effectuer les réglages de la façon suivante:

1. Porter le bras acoustique vers le mandrin central. Monter le protecteur de l'aiguille, si fourni, pour protéger l'aiguille contre tout endommagement éventuel.
2. Tourner à droite ou à gauche la vis de réglage tout en poussant le lève-bras vers le bas.

Rotation à droite

— La distance entre le disque et la pointe de l'aiguille, est réduite.

Rotation à gauche

— La distance entre le disque et la pointe de l'aiguille, est augmentée.

Note:

Comme la vis de réglage présente une tête hexagonale, s'assurer d'effectuer le réglage tout en enfonçant la lève-bras, sinon la vis ne se déplacera pas normalement. De plus, s'assurer que la tête hexagonale se rétracte correctement dans le lève-bras quand ce dernier est libéré.

● Réglage de la suppression de sensibilité

Cet appareil présente un commutateur de suppression de sensibilité qui élimine les parasites provoqués quand l'aiguille est posée sur le disque ou quand elle en est retirée. Si le son n'est pas immédiatement entendu ou si un parasite est entendu quand l'aiguille est posée sur le disque, régler des phénomènes à l'aide de la vis de réglage de la suppression de sensibilité (Photographie 21).

■ JUSTIERUNG (Tonarm)

● Justierung für automatische Rückstellung

1. Netzschalter auf OFF halten, um Drehen des Plattentellers zu verhüten.
2. Die Gummidecke abnehmen.
3. Den Tonarm gegen die Mittelspindel bewegen, und unter langsamer Drehung der Justierschraube regulieren.

Wenn der Tonarm geneigt ist, sich schon vor Spielablauf zurückzustellen:

— Die Schraube im Gegensinn zum Uhrzeiger drehen. (Vgl. Foto 18 A)

Wenn sich der Tonarm nach der letzten Führungsrille nicht zurückstellt:

— Die Schraube im Uhrzeigersinn drehen. (Vgl. Foto 18 B)

Justierung der Armhubhöhe (Siehe Foto 19 und 20)

Die Armhubhöhe (Abstand zwischen Nadelspitze und Plattenoberfläche, wenn sich Einsatzhebel an der Oberstellung befindet) ist bereits vor Verschiffung im Werk auf ca. 5 – 10 mm eingestellt.

Zum Gebrauch verschiedener handelsüblicher Tonabnehmer, oder wenn weitere Justierungen praktisch notwendig sind, Justierung folgendermaßen durchführen:

1. Den Tonarm gegen die Mittelspindel bewegen. Wenn erhältlich den Nadelschoner anbringen, um die Nadelspitze vor Beschädigung zu schützen.
2. Unter Niederdrücken des Armhubhebels die Justierschraube rechts oder links drehen.

Rechtsdrehung

— Abstand zwischen Schallplatte und Nadelspitze nimmt ab.

Links drehung

— Abstand zwischen Schallplatte und Nadelspitze nimmt zu.

Anmerkung:

Da die Justierschraube einen Sechskantkopf aufweist, bei Justierung unbedingt den Armhubhebel niederdrücken, sonst bewegt sich die Schraube nicht frei.

Feststellen, daß der Sechskantkopf richtig in den Armhubhebel einzieht, wenn der letztere gelöst wird.

● Stummabstimmung

In dem Gerät ist ein Schalter für Stummabstimmung eingesetzt, um Geräusch zu beseitigen, das beim Auflegen der Nadel auf die Platte oder beim Wegnehmen davon entsteht. Wenn der Schall nicht direkt zu hören ist oder beim Herabsetzen der Nadel auf die Platte Geräusch entsteht, unter Drehen der Stummabstimmungsschraube justieren. (Foto 21)

■ BLOCK DIAGRAM (Control Circuit, Arm Control Circuit and Pitch Control Circuit)

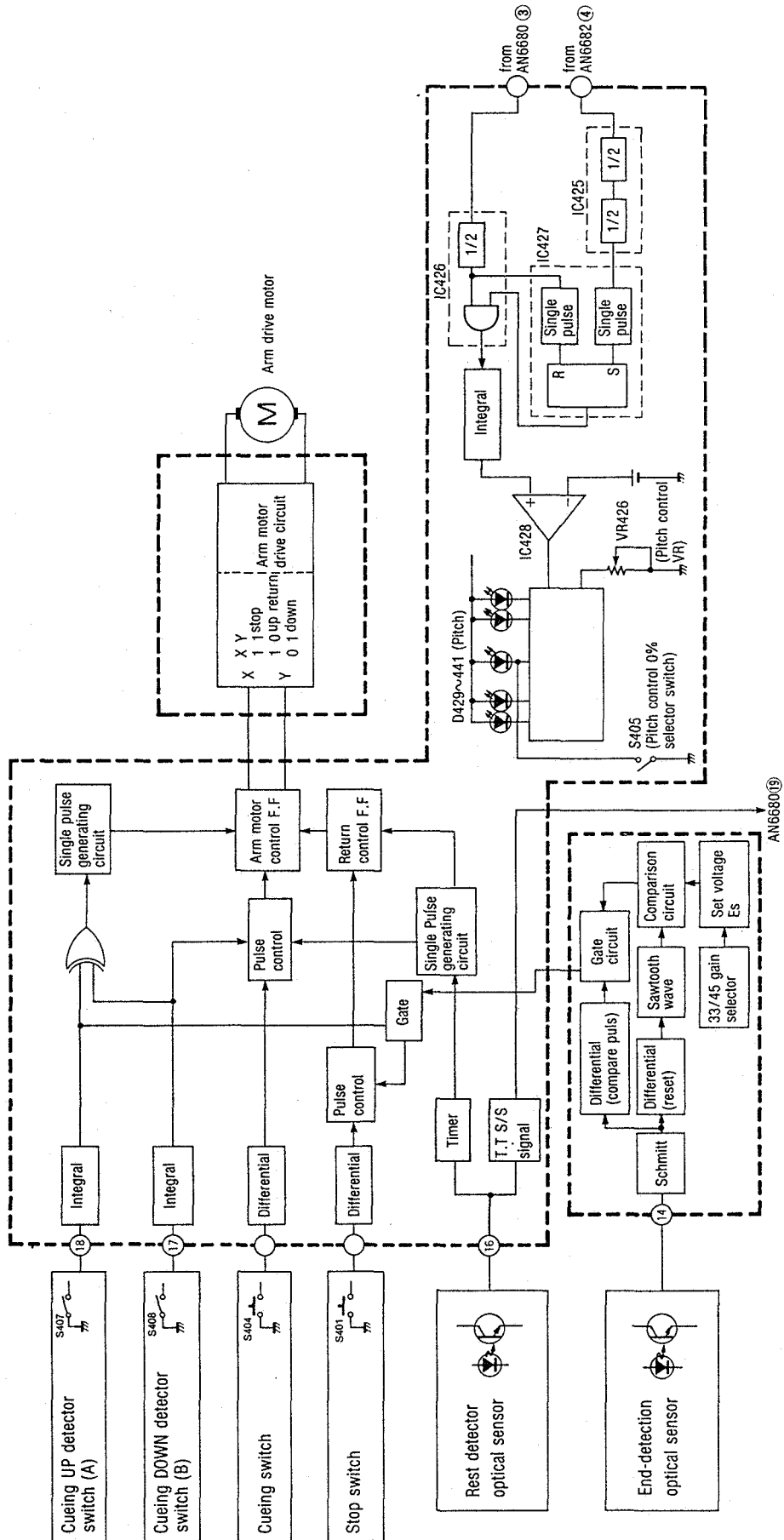

■ BLOCK DIAGRAM (Drive Circuit)

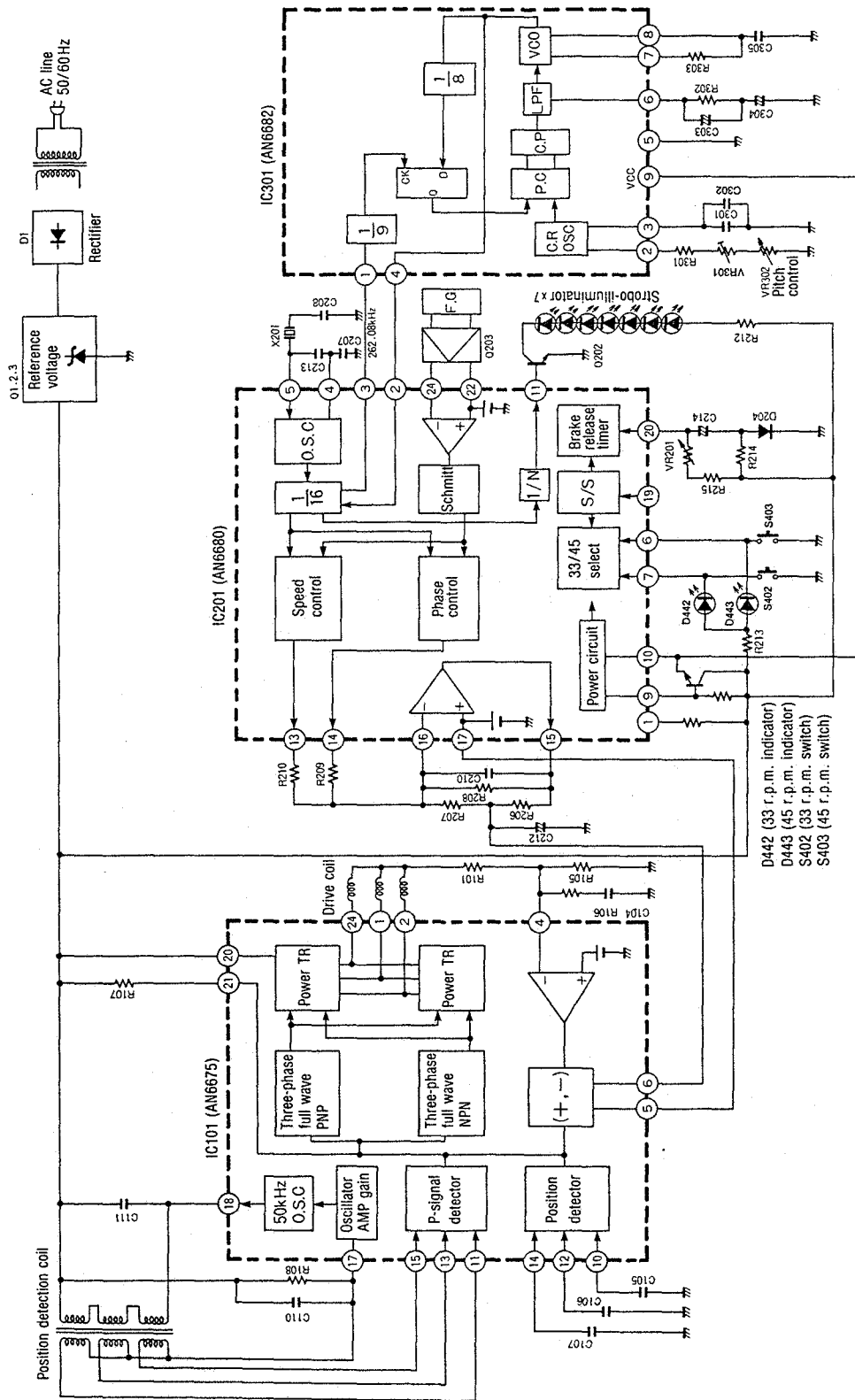

D442 (33 r.p.m. indicator)
 D443 (45 r.p.m. indicator)
 S402 (33 r.p.m. switch)
 S403 (45 r.p.m. switch)

REPLACEMENT PARTS LIST (Electric Parts)

- Notes:** 1. Part numbers are indicated on most mechanical parts. Please use this part number for parts orders.
2. Δ indicates that only parts specified by the manufacture be used for safety.

Ref. No.	Part No.	Part Name & Description
INTEGRATED CIRCUITS		
IC1 IC101 IC201 IC301 IC302, 427, 455 456, 457, 459 IC425, 426, 460 IC428 IC429 IC458 IC501	SV μ PC14312 AN6675 AN6680 AN6682 SVITC4011BP SVITC4013BP AN6552 SVIMS1901P SVITC4023BP SVIMSM4011M	Integrated Circuit, Reference Voltage Integrated Circuit, Drive Integrated Circuit, Control Integrated Circuit Integrated Circuit, CMOS Integrated Circuit, CMOS Integrated Circuit Integrated Circuit Integrated Circuit Integrated Circuit, CMOS
TRANSISTORS		
Q1 Q2, 3, 202 Q201 Q203 Q425, 426, 428, 429, 455, 456, 457, 501, 502, 503, 504, 508, 509, 512, 513 Q427 Q430, 505 Q506, 510 Q507, 511	2SD389A-Q 2SD637 2SC1846-R 2SC1328-T 2SD636 2SC1047-T 2SB641 2SD638 2SB643	Transistor Transistor Transistor Transistor Transistor Transistor Transistor Transistor Transistor
DIODES		
D1, 3 D2, 301 D204, 425, 427, 428, 451, 457, 458, 459, 501, 502, 503, 504, 505 D426 D429~434, 442 436~441, 443 D435 D455, 456 D444, 445, 446, 447, 448, 449, 450	Δ SVDS1RBA40 MA1051 MA162A MA26TO-A SVDGL-9PR2 2-0A90 SVDGD4205ALC	Rectifier Diode, 5V Zener Diode Diode Light Emitting Diode, Pitch Control, Speed Selector Light Emitting Diode, Pitch Control Diode Light Emitting Diode
CRYSTAL		
X201	SVQU306115	Crystal, 4.19328MHz Oscillator
TRANSFORMER		
P.T.	Δ SLTF5899	Transformer, Power Source
LAMP		
PL1	SFDN172-01	Lamp, Stylus Illuminator
FUSE		
F1 F2, 3	Δ XBAS2C025T1A Δ XBA2C08TRO	Fuse, T250mA (250V) Fuse, T800mA (250V)
VARIABLE RESISTORS		
VR201 VR301 VR425 VR426 VR501 VR502	EVLS6AA00B54 EVMH1GA00B53 EVTS6AA00B52 EVHJXB001A24 EVLS6AA00B24 EVLS6AA00B55	Braking Adjustment, 50k Ω (B) Pitch Control \pm 0% Adjustment, 5k Ω (B) Pitch Control LED Adjustment, 500 Ω (B) Pitch Control and Pitch Control Switch Optical Sensor Gain Adjustment, 20k Ω (B) Auto-Return Time Adjustment, 500k Ω (B)
SWITCHES		
S401~404	EVQP5R04K	Switch, Stop, 33 r.p.m. and 45 r.p.m. Selector

Ref. No.	Part No.	Part Name & Description
S406 S407, 408 S501 S601 S701 S602	SFDSD2MSL-4 SFDSD2MS-4 ESB6237 Δ SFDSS5GL2S SFDHSW0665B Δ SFDHSXW13312	Switch, Stylus Illuminator Switch, Cueing Down/Cueing Up Switch, Manual Switch, Power Switch, Muting Switch, Power Selector
PHOTO INTERRUPTER		
PH402	ON1128	Photo Interrupter
RESISTORS		
R1 R2 R3 R4 R5 R101 R102 R103 R104 R105 R106	ERD25FJ562 ERD25FJ682 ERD25FJ272 ERD25FJ561 ERD25TJ471 ERD25FJ103 ERX1ANJ4R7 ERD25FJ472 ERD25TJ473 ERD25FJ103 ERD25FJ150	Carbon, 5.6k Ω , 1/4W, \pm 5% Carbon, 6.8k Ω , 1/4W, \pm 5% Carbon, 2.7k Ω , 1/4W, \pm 5% Carbon, 560 Ω , 1/4W, \pm 5% Carbon, 470 Ω , 1/4W, \pm 5% Carbon, 10k Ω , 1/4W, \pm 5% Metal Film, 4.7 Ω , 1W, \pm 5% Carbon, 4.7k Ω , 1/4W, \pm 5% Carbon, 47k Ω , 1/4W, \pm 5% Carbon, 10k Ω , 1/4W, \pm 5% Carbon, 15 Ω , 1/4W, \pm 5%
R107 R108 R109, 110 R201 R202 R203 R204 R205 R206 R207	Δ ERX1ANJ1R5 ERD25FJ103 ERX1ANJ4R7 Δ ERG1ANJ561 ERD25FJ103 ERD25FJ470 ERD25FJ272 ERD25TJ124 ERD25TJ183 ERD25TJ563	Metal Film, 1.5 Ω , 1W, \pm 5% Carbon, 10k Ω , 1/4W, \pm 5% Metal Film, 4.7 Ω , 1W, \pm 5% Metal Oxide, 560 Ω , 1W, \pm 5% Carbon, 10k Ω , 1/4W, \pm 5% Carbon, 47 Ω , 1/4W, \pm 5% Carbon, 2.7k Ω , 1/4W, \pm 5% Carbon, 120k Ω , 1/4W, \pm 5% Carbon, 18k Ω , 1/4W, \pm 5% Carbon, 56k Ω , 1/4W, \pm 5%
R208 R209 R210 R211 R212 R213 R214 R215 R216 R217 R218 R219 R220 R221 R222 R301 R302 R303 R304 R306 R307 R308, 309 R425 R426, 427 R428 R429 R430, 431 R432 R433 R434 R435 R436 R437 R438 R439 R440 R441 R442 R443 R444	ERD25TJ224 ERD25TJ154 ERD25TJ223 ERD25FJ103 ERD25FJ121 ERD25FJ122 ERD25TJ223 ERD25FJ103 ERD25TJ154 ERD25TJ223 ERD25FJ102 ERD25FJ332 ERD25FJ221 ERD25FJ471 ERD25FJ391 ERO25CKF3301 ERD25FJ471 ERD25FJ822 ERD25FJ152 ERD25TJ223 ERD25TJ103 ERD25TJ223 ERD25TJ223 ERD25FJ103 ERD25FJ103 ERD25TJ223 ERD25FJ103 ERD25FJ103 ERD25TJ223 ERD25TJ473 ERD25FJ102 ERD25TJ104 ERD25FJ152 ERD25FJ562 ERO25CKF1802 ERO25CKF4303 ERD25FJ103 ERD25FJ471 ERD25FJ101 ERD25FJ681	Carbon, 220k Ω , 1/4W, \pm 5% Carbon, 150k Ω , 1/4W, \pm 5% Carbon, 22k Ω , 1/4W, \pm 5% Carbon, 10k Ω , 1/4W, \pm 5% Carbon, 120 Ω , 1/4W, \pm 5% Carbon, 1.2k Ω , 1/4W, \pm 5% Carbon, 22k Ω , 1/4W, \pm 5% Carbon, 10k Ω , 1/4W, \pm 5% Carbon, 150k Ω , 1/4W, \pm 5% Carbon, 22k Ω , 1/4W, \pm 5% Carbon, 1k Ω , 1/4W, \pm 5% Carbon, 3.3k Ω , 1/4W, \pm 5% Carbon, 220 Ω , 1/4W, \pm 5% Carbon, 470 Ω , 1/4W, \pm 5% Carbon, 8.2k Ω , 1/4W, \pm 5% Carbon, 1.5k Ω , 1/4W, \pm 5% Carbon, 22k Ω , 1/4W, \pm 5% Carbon, 10k Ω , 1/4W, \pm 5% Carbon, 22k Ω , 1/4W, \pm 5% Carbon, 22k Ω , 1/4W, \pm 5% Carbon, 10k Ω , 1/4W, \pm 5% Carbon, 22k Ω , 1/4W, \pm 5% Carbon, 22k Ω , 1/4W, \pm 5% Carbon, 10k Ω , 1/4W, \pm 5% Carbon, 10k Ω , 1/4W, \pm 5% Carbon, 22k Ω , 1/4W, \pm 5% Carbon, 47k Ω , 1/4W, \pm 5% Carbon, 1k Ω , 1/4W, \pm 5% Carbon, 100k Ω , 1/4W, \pm 5% Carbon, 1.5k Ω , 1/4W, \pm 5% Carbon, 5.6k Ω , 1/4W, \pm 5% Metal Film, 18k Ω , 1/4W, \pm 1% Metal Film, 430k Ω , 1/4W, \pm 1% Carbon, 10k Ω , 1/4W, \pm 5% Carbon, 470 Ω , 1/4W, \pm 5% Carbon, 100 Ω , 1/4W, \pm 5% Carbon, 680 Ω , 1/4W, \pm 5%

SL-1700MK2/ SL-1710MK2

SL-1700MK2(XG) → [XG] SL-1700MK2(XGF) → [XGF] SL-1700MK2(XGB) → [XGB]
 SL-1700MK2(E) → [E] SL-1700MK2(XA) → [XA] SL-1700MK2(XGE) → [XGE]
 SL-1700MK2A(XA) → [AXA] SL-1700MK2A(XG) → [AXG] SL-1700MK2A(E) → [AE]
 SL-1710MK2(XG) → [10XG] SL-1710MK2(E) → [10E] SL-1710MK2A(XG) → [10AXG]
 SL-1710MK2A(E) → [10AE]

Ref. No.	Part No.	Part Name & Description
R445	ERD25FJ102	Carbon, 1kΩ, 1/4W, ± 5%
R446	ERD25FJ222	Carbon, 2.2kΩ, 1/4W, ± 5%
R447	ERD25TJ123	Carbon, 12kΩ, 1/4W, ± 5%
R448	ERD25TJ103	Carbon, 10kΩ, 1/4W, ± 5%
R449	ERD25FJ152	Carbon, 1.5kΩ, 1/4W, ± 5%
R450	ERD25FJ821	Carbon, 820Ω, 1/4W, ± 5%
R451	ERD25TJ473	Carbon, 47kΩ, 1/4W, ± 5%
R455	ERD25TJ123	Carbon, 12kΩ, 1/4W, ± 5%
R456	ERD25TJ473	Carbon, 47kΩ, 1/4W, ± 5%
R457	ERD25TJ223	Carbon, 22kΩ, 1/4W, ± 5%
R458	ERD25TJ123	Carbon, 12kΩ, 1/4W, ± 5%
R459	ERD25TJ473	Carbon, 47kΩ, 1/4W, ± 5%
R460	ERD25TJ223	Carbon, 22kΩ, 1/4W, ± 5%
R461, 462	ERD25TJ104	Carbon, 100kΩ, 1/4W, ± 5%
R463	ERD25TJ223	Carbon, 22kΩ, 1/4W, ± 5%
R464	ERD25TJ104	Carbon, 100kΩ, 1/4W, ± 5%
R465	ERD25FJ681	Carbon, 680Ω, 1/4W, ± 5%
R466	ERD25FJ562	Carbon, 5.6kΩ, 1/4W, ± 5%
R467	ERD25TJ473	Carbon, 47kΩ, 1/4W, ± 5%
R468	ERD25TJ223	Carbon, 22kΩ, 1/4W, ± 5%
R469	ERD25FJ681	Carbon, 680Ω, 1/4W, ± 5%
R470	ERD25FJ562	Carbon, 5.6kΩ, 1/4W, ± 5%
R471	ERD25TJ473	Carbon, 47kΩ, 1/4W, ± 5%
R472	ERD25TJ223	Carbon, 22kΩ, 1/4W, ± 5%
R473	ERD25TJ474	Carbon, 470kΩ, 1/4W, ± 5%
R474	ERD25FJ681	Carbon, 680Ω, 1/4W, ± 5%
R475, 476	ERD25TJ473	Carbon, 47kΩ, 1/4W, ± 5%
R477, 478	ERD25TJ473	Carbon, 47kΩ, 1/4W, ± 5%
R479	ERD25FJ562	Carbon, 5.6kΩ, 1/4W, ± 5%
R480	ERD25TJ473	Carbon, 47kΩ, 1/4W, ± 5%
R481	ERD25TJ104	Carbon, 100kΩ, 1/4W, ± 5%
R482	ERD25TJ223	Carbon, 22kΩ, 1/4W, ± 5%
R483	ERD25TJ123	Carbon, 12kΩ, 1/4W, ± 5%
R484	ERD25TJ223	Carbon, 22kΩ, 1/4W, ± 5%
R485	ERD25TJ474	Carbon, 470kΩ, 1/4W, ± 5%
R486	ERD25TJ223	Carbon, 22kΩ, 1/4W, ± 5%
R487	ERD25TJ474	Carbon, 470kΩ, 1/4W, ± 5%
R488, 489	ERD25TJ473	Carbon, 47kΩ, 1/4W, ± 5%
R501	ERD25FJ681	Carbon, 680Ω, 1/4W, ± 5%
R502	ERD25FJ102	Carbon, 1kΩ, 1/4W, ± 5%
R503	ERD25TJ183	Carbon, 18kΩ, 1/4W, ± 5%
R504	ERD25TJ473	Carbon, 47kΩ, 1/4W, ± 5%
R505, 506	ERD25TJ274	Carbon, 270kΩ, 1/4W, ± 5%
R507	ERD25TJ274	Carbon, 270kΩ, 1/4W, ± 5%
R508	ERD25TJ393	Carbon, 39kΩ, 1/4W, ± 5%
R509	ERD25FJ221	Carbon, 220Ω, 1/4W, ± 5%
R510	ERD25TJ824	Carbon, 820kΩ, 1/4W, ± 5%
R511	ERD25TJ333	Carbon, 33kΩ, 1/4W, ± 5%
R512	ERD25TJ183	Carbon, 18kΩ, 1/4W, ± 5%
R513	ERD25TJ473	Carbon, 47kΩ, 1/4W, ± 5%
R514	ERD25TJ123	Carbon, 12kΩ, 1/4W, ± 5%
R515	ERD25FJ472	Carbon, 4.7kΩ, 1/4W, ± 5%
R516	ERD25TJ473	Carbon, 47kΩ, 1/4W, ± 5%
R517	ERD25TJ393	Carbon, 39kΩ, 1/4W, ± 5%
R518	ERD25FJ102	Carbon, 1kΩ, 1/4W, ± 5%
R519	ERD25FJ332	Carbon, 3.3kΩ, 1/4W, ± 5%
R520	ERD25FJ222	Carbon, 2.2kΩ, 1/4W, ± 5%
R521	ERD25FJ471	Carbon, 470Ω, 1/4W, ± 5%
R522	ERD25TJ473	Carbon, 47kΩ, 1/4W, ± 5%
R523	ERD25FJ102	Carbon, 1kΩ, 1/4W, ± 5%
R524	ERD25FJ332	Carbon, 3.3kΩ, 1/4W, ± 5%
R525	ERD25FJ102	Carbon, 1kΩ, 1/4W, ± 5%
R526	ERD25FJ471	Carbon, 470Ω, 1/4W, ± 5%
R527	ERD25TJ473	Carbon, 47kΩ, 1/4W, ± 5%
R528	ERD25FJ681	Carbon, 680Ω, 1/4W, ± 5%
R529, 530	ERD25TJ123	Carbon, 12kΩ, 1/4W, ± 5%
R531	ERD25TJ104	Carbon, 100kΩ, 1/4W, ± 5%
R601	ERD25TJ477	Carbon, 4.7Ω, 1/4W, ± 5%

CAPACITORS

Ref. No.	Part No.	Part Name & Description
C1	ECEB1HS471	Electrolytic, 470μF, 50V
C2	ECEA1VS330	Electrolytic, 33μF, 35V
C3	ECEA1ES220	Electrolytic, 22μF, 25V
C4	ECEB1HS471	Electrolytic, 470μF, 50V
C5	ECEA1ES101	Electrolytic, 100μF, 25V
C101, 102	ECEA1VS330	Electrolytic, 33μF, 35V
C103	ECEA1VS330	Electrolytic, 33μF, 35V
C104, 105	ECQM1H104KZ	Polyester, 0.1μF, 50V, ±10%
C106, 107	ECQM1H104KZ	Polyester, 0.1μF, 50V, ±10%
C108	ECEA1ES101	Electrolytic, 100μF, 25V
C109, 110	ECQM1H104KZ	Polyester, 0.1μF, 50V, ±10%
C111	ECQM1H562KZ	Polyester, 0.0056μF, 50V, ±10%
C112	ECEA1JS477	Electrolytic, 4.7μF, 63V
C201	ECEA1CS330	Electrolytic, 33μF, 16V
C202, 203	ECEA50Z1	Electrolytic, 1μF, 50V
C204	ECQM1H473KZ	Polyester, 0.047μF, 50V, ±10%
C205	ECEA1AS221	Electrolytic, 220μF, 10V
C206	ECEA50Z1	Electrolytic, 1μF, 50V
C207	ECCD1H101K	Ceramic, 100pF, 50V, ±10%
C208	ECCD1H390K	Ceramic, 39pF, 50V, ±10%
C209	ECEA1ES101	Electrolytic, 100μF, 25V
C210	ECQM1H224KZ	Polyester, 0.22μF, 50V, ±10%
C211	ECQM1H473KZ	Polyester, 0.047μF, 50V, ±10%
C212	ECEA50Z3R3	Electrolytic, 3.3μF, 50V
C213	ECCD1H471K	Ceramic, 470pF, 50V, ±10%
C214	ECEA1ES101	Electrolytic, 100μF, 25V
C215	ECEA50Z1	Electrolytic, 1μF, 50V
C216	ECEA1ES470	Electrolytic, 47μF, 25V
C301, 302	ECQK1123FZ	Polyester, 0.012μF, 125V, ±1%
C303	ECEA50Z1	Electrolytic, 1μF, 50V
C304	ECEA1HS100	Electrolytic, 10μF, 50V
C305	ECQM1H122KZ	Polyester, 0.0012μF, 50V, ±10%
C306	ECEA50Z1	Electrolytic, 1μF, 50V
C425, 426	ECCD1H101K	Ceramic, 100pF, 50V, ±10%
C427, 428	ECCD1H101K	Ceramic, 100pF, 50V, ±10%
C429, 430	ECQM1H473KZ	Polyester, 0.047μF, 50V, ±10%
C431	ECEA1HS100	Electrolytic, 10μF, 50V
C432, 433	ECKD1E104ZF	Ceramic, 0.1μF, 25V, ±8%
C434, 435	ECKD1E104ZF	Ceramic, 0.1μF, 25V, ±8%
C455, 456	ECEA50ZR47	Electrolytic, 0.47μF, 50V
C457	ECQM1H102KZ	Polyester, 0.001μF, 50V, ±10%
C458	ECQM1H103KZ	Polyester, 0.01μF, 50V, ±10%
C459	ECEA50ZR47	Electrolytic, 0.47μF, 50V
C460	ECQM1H562KZ	Polyester, 0.0056μF, 50V, ±10%
C461	ECQM1H102KZ	Polyester, 0.001μF, 50V, ±10%
C462	ECEA50ZR47	Electrolytic, 0.47μF, 50V
C463	ECQM1H562KZ	Polyester, 0.0056μF, 50V, ±10%
C464, 465	ECEA50ZR47	Electrolytic, 0.47μF, 50V
C466	ECEA1HS100	Electrolytic, 10μF, 50V
C467, 468	ECQM1H103KZ	Polyester, 0.01μF, 50V, ±10%
C469	ECEA50ZR47	Electrolytic, 0.47μF, 50V
C470	ECKD1E104ZF	Ceramic, 0.1μF, 25V, ±8%
C471	ECEA1ES470	Electrolytic, 47μF, 25V
C472	ECKD1E104ZF	Ceramic, 0.1μF, 25V, ±8%
C473	ECEA1ES470	Electrolytic, 47μF, 25V
C501	ECEA50ZR1	Electrolytic, 0.1μF, 50V
C502	ECQM1H473KZ	Polyester, 0.047μF, 50V, ±10%
C503	ECQM1H184KZ	Polyester, 0.18μF, 50V, ±10%
C504	ECQM1H473KZ	Polyester, 0.047μF, 50V, ±10%
C505	ECEA25Z4R7	Electrolytic, 4.7μF, 25V
C506	ECQM1H104KZ	Polyester, 0.1μF, 50V, ±10%
C507, 508	ECQM1H103KZ	Polyester, 0.01μF, 50V, ±10%
C509	ECKD1E104ZF	Ceramic, 0.1μF, 25V, ±8%
C510	ECEA1ES101	Electrolytic, 100μF, 25V
C601 [XG, XGF, XGB, AXA, 10XG, AXG, 10AXG, XA]	ECQE2A473MZ	Polyester, 0.047μF, 250V, ±20%
C601 [E, 10E, AE, 10AE, XGE, 10XGE]	ECNC4A473M	Paper, 0.047μF, 450V, ±20%

■ CONTROL CIRCUIT BOARD

Earth (Ground) Lines

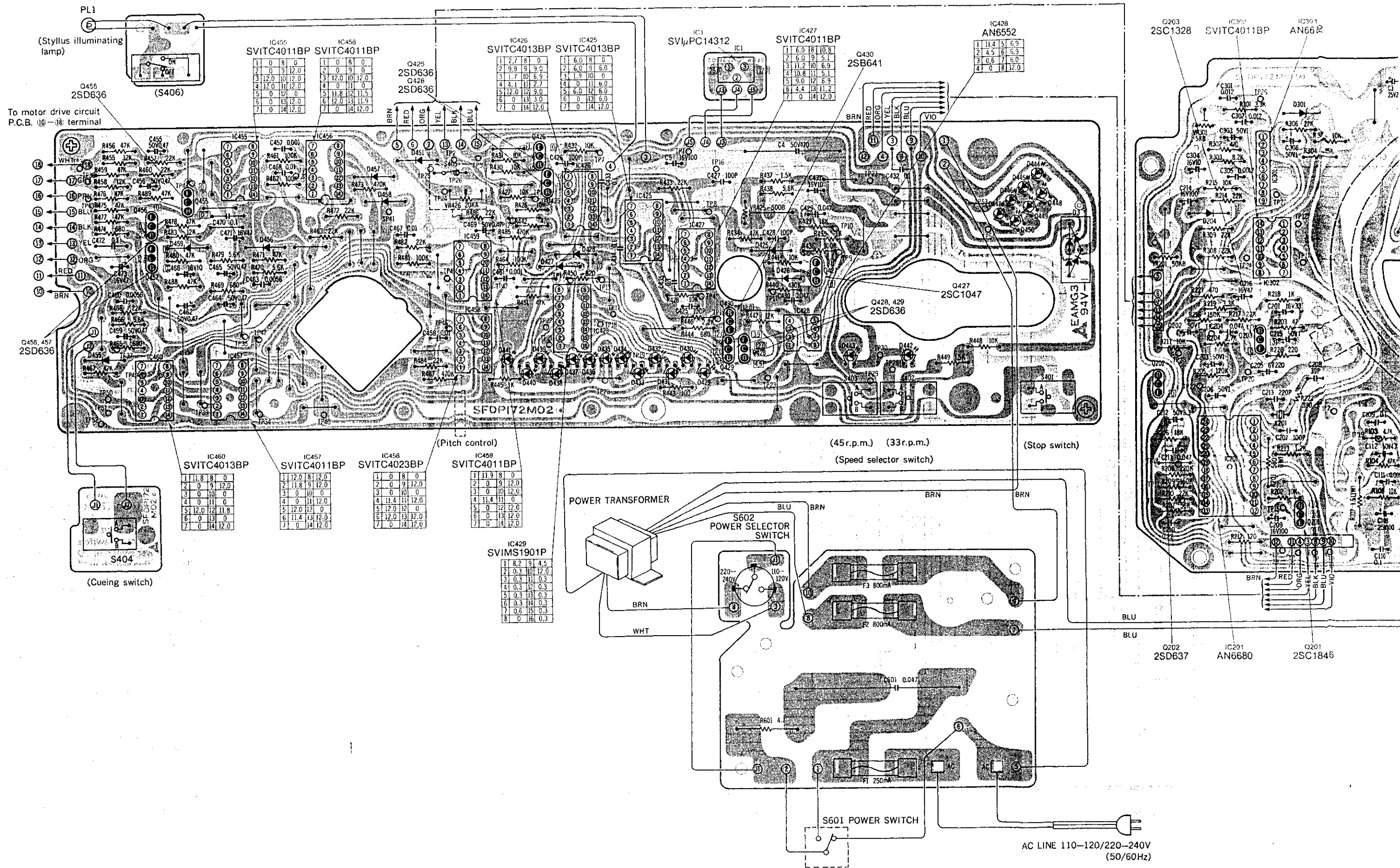

■ DRIVE CIRCUIT BOARD

Earth (Ground) Lines

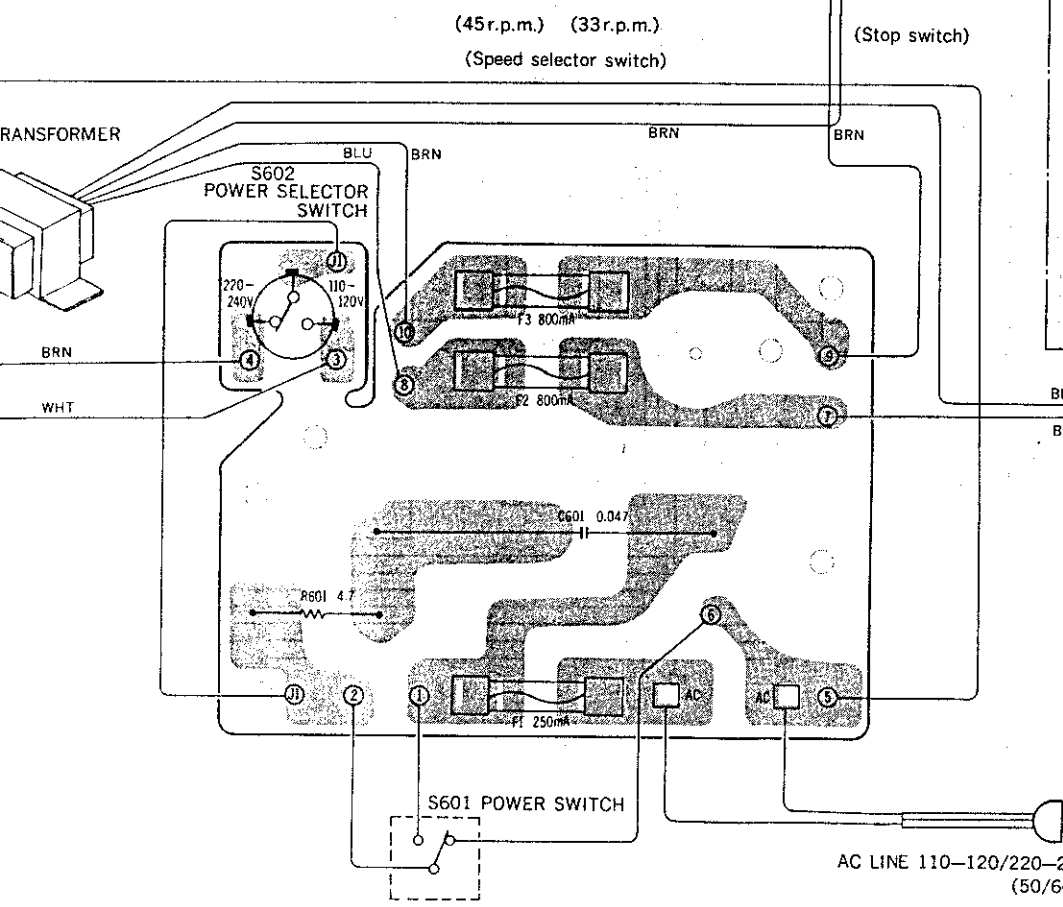
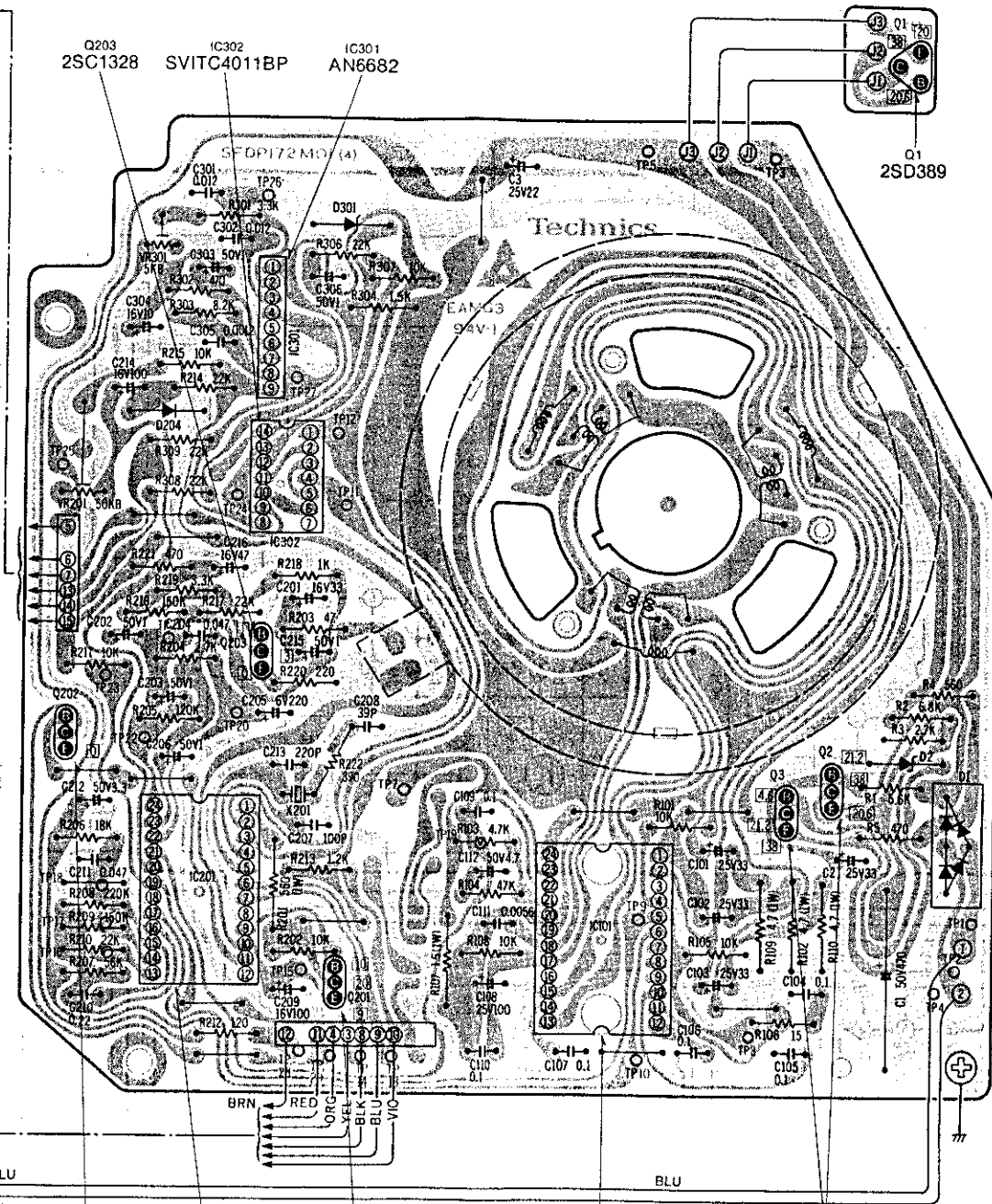
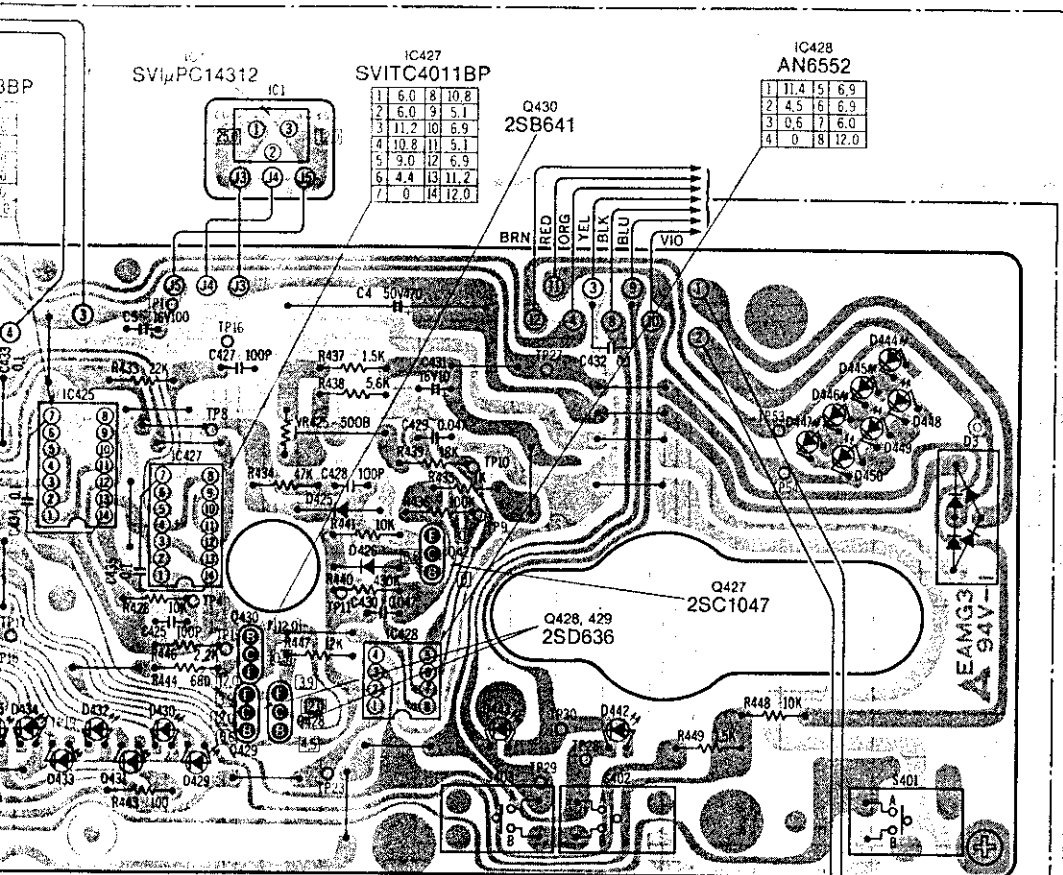

■ TERMINAL GUIDE OF TRANSISTOR AND IC

<p>SVIμPC14312</p>	<p>AN6675</p>	<p>AN6680</p>
<p>AN6682</p>	<p>SVITC4011BP</p>	<p>SVITC4013BP</p>
<p>AN6552</p>	<p>SVIMSM1901P</p>	<p>2SD389</p>
<p>2SD637, 2SD638, 2SD636, 2SB641, 2SB643</p>	<p>2SC1846</p>	<p>2SC1328, 2SC1047</p>

■ SCHEMATIC DIAGRAM 1 (Control Circuit Board)

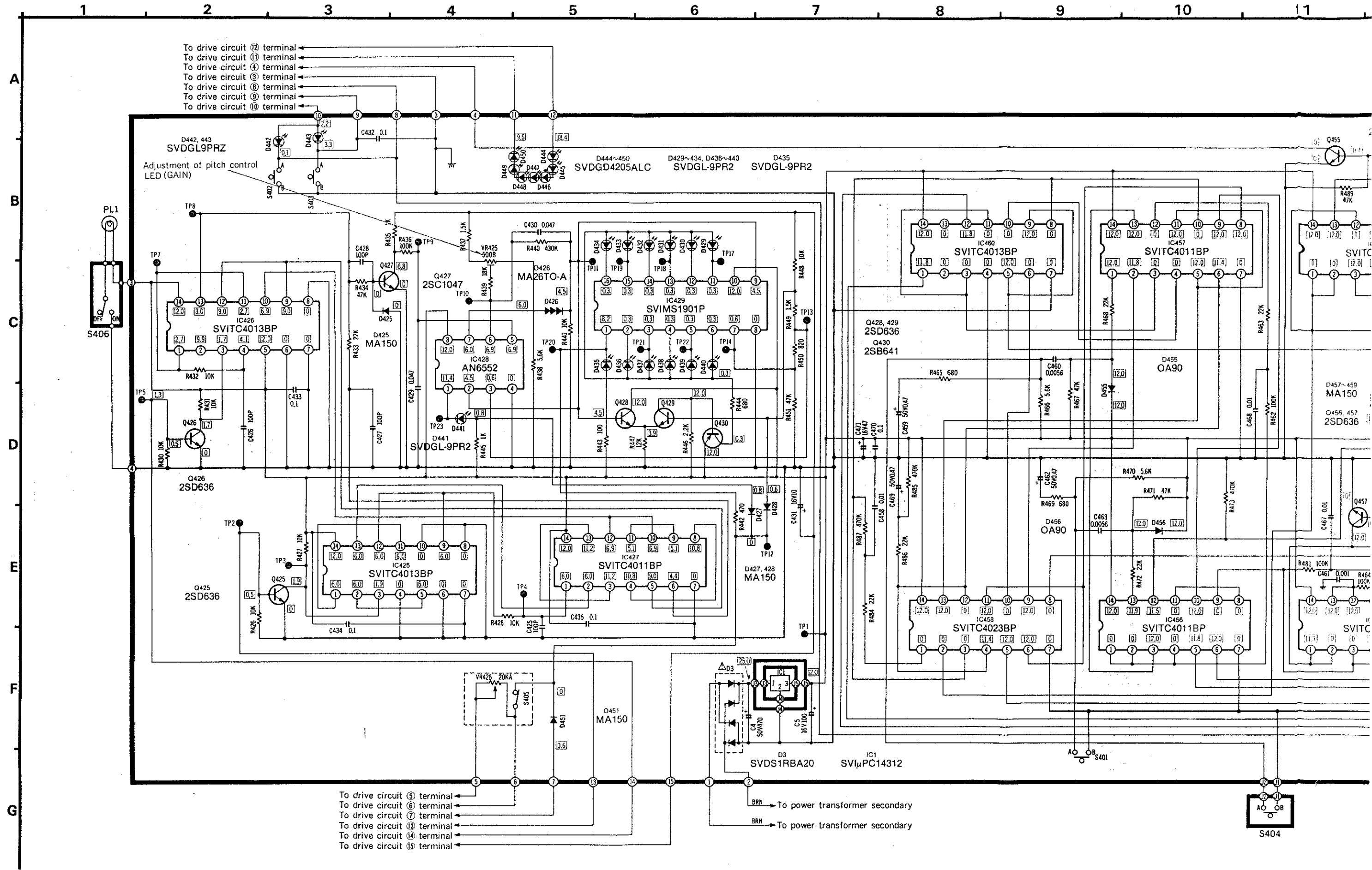

SL-1700MK2/ SL-1700MK2/
SL-1710MK2 SL-1710MK2

6 7 8 9 10 11 12 13 14

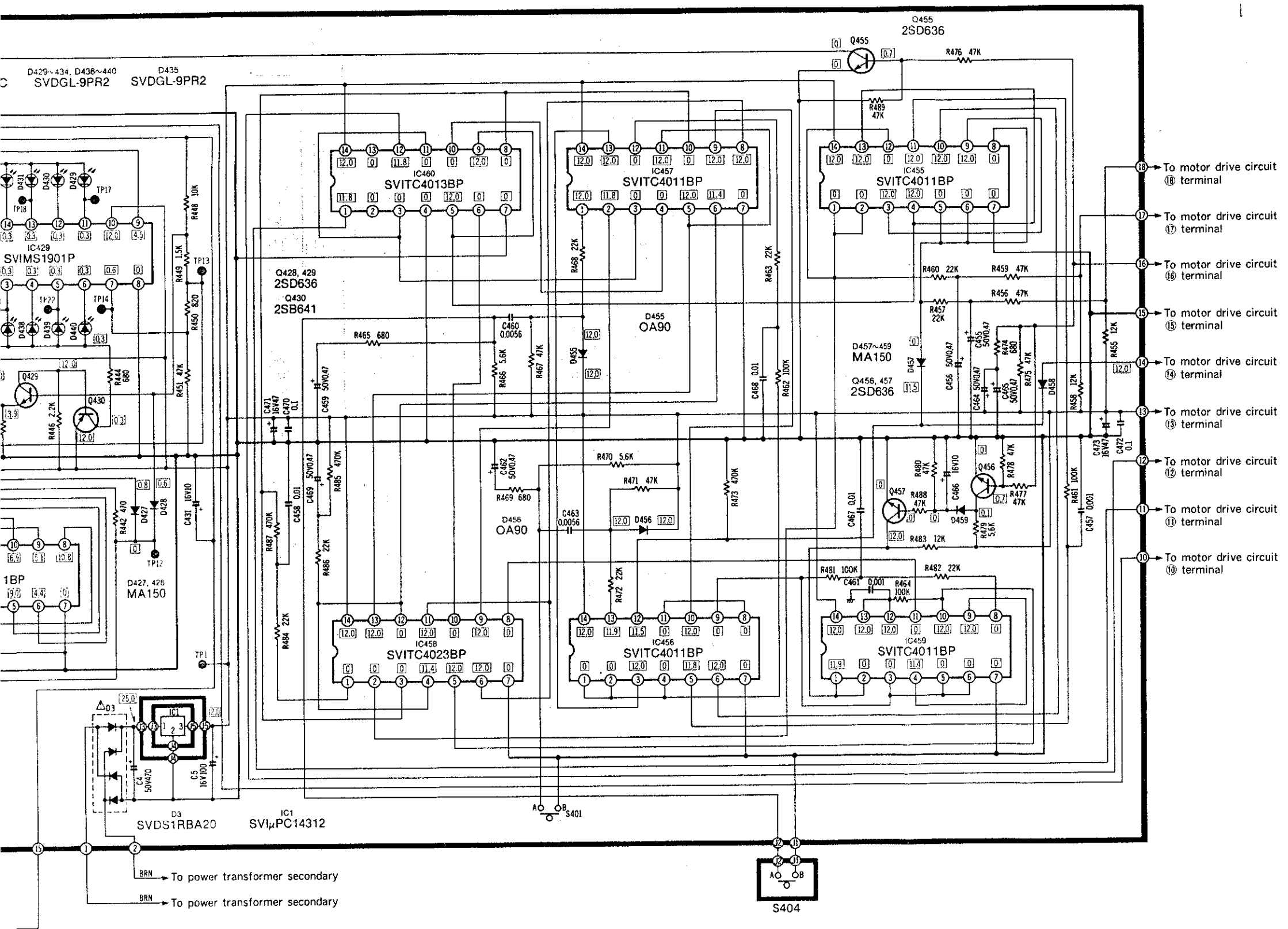

- NOTES:**
1. S401: Stop switch in "OFF" position. (not-push condition)
 2. S402: Speed selector switch (33 r.p.m.) in "ON" position. (push condition)
 3. S403: Speed selector switch (45 r.p.m.) in "OFF" position. (not-push condition)
 4. S404: Cueing switch in "OFF" position. (not-push condition)
 5. S405: Pitch control switch in "ON" position. (Center position)
 6. S406: Stylus-illuminator switch in "OFF" position.
 7. S407: Cueing-up detector switch in "ON" position. (Arm Lift-down position)
 8. S408: Cueing-down detector switch in "ON" position. (Arm Lift-down position)
 9. S501: Auto-return switch in "ON" position.
 10. S601: Power switch in "ON" position.
 11. S701: Muting switch in "OFF" position.
 12. S602: Power selector switch in "220-240V" position.
 13. [] Indicated voltage values are the voltage when the arm lift is at a stop in the lowest position.
 14. () Indicated voltage values are the voltage when the arm lift is moving up. (The arm drive motor is rotating reversely at a high speed.)
 15. [] Indicated voltage values are the voltage when the arm lift is moving down. (The arm drive motor is rotating in forward direction at a low speed.)
- *The drive circuit IC voltage and wave form are not indicated inside the circuit. So, refer to the Voltage and Wave Form of Each IC Terminal.
16. Indicated voltage values are the standard values for the unit measured by the DC electronic circuit tester (high impedance) with the chassis taken as standard. Therefore, there may exist some errors in the voltage values, depending on the internal impedance of the DC circuit tester.
 17. This schematic diagram may be modified at any time with the development of new technology.
 18. Δ indicates that only parts specified by the manufacturer be used for safety.

SCHEMATIC DIAGRAM 2 (Drive Circuit Board)

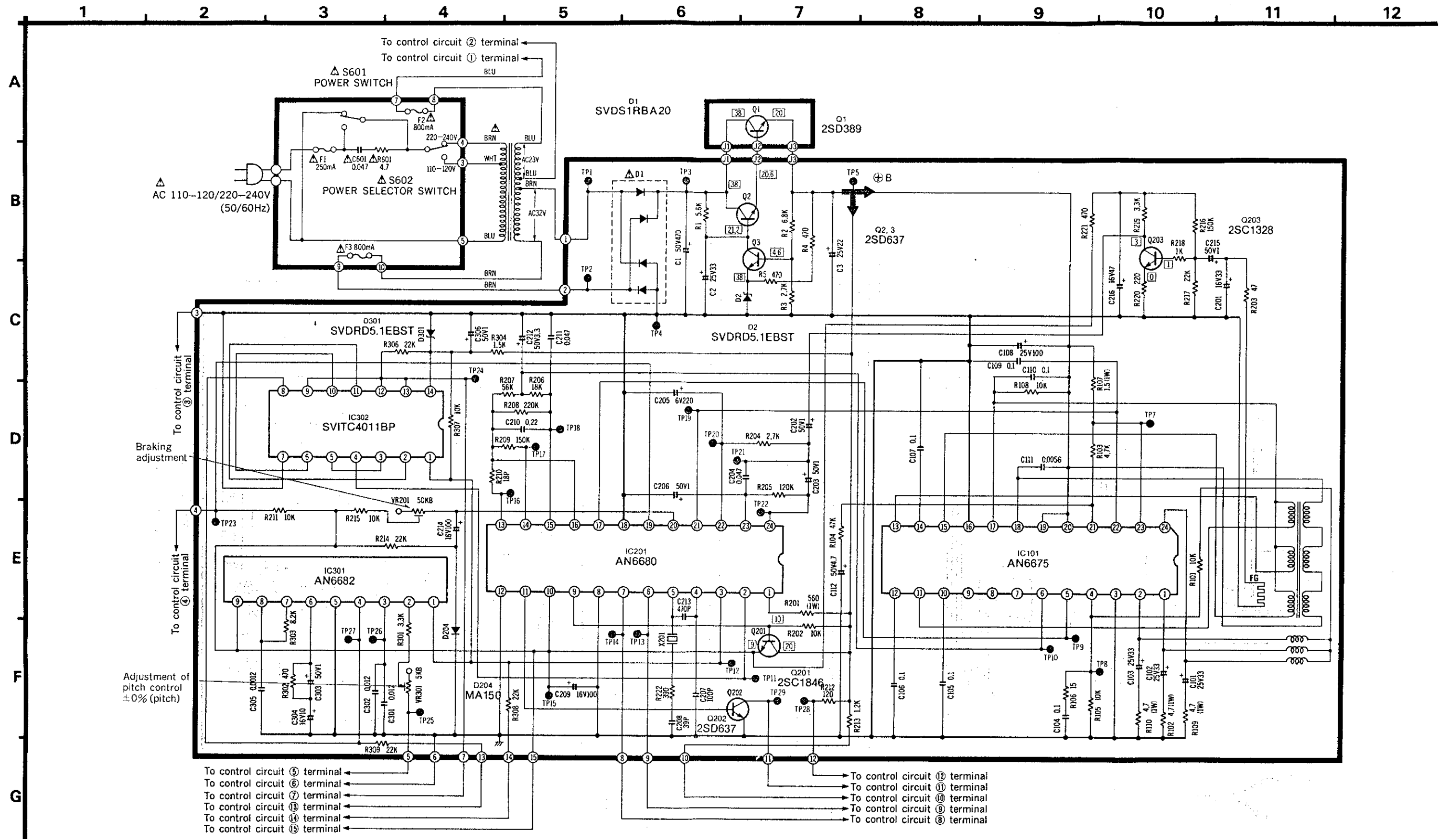

IC302 (SVITC4011BP)

Start	Stop	Start	Stop	Start	Stop
① Same as at right		⑤ Same as at right		⑨ 0.6V	0.6V
② 5V	5V	⑥ 5V	5V	⑩ 5V	5V
③ Same as at right		⑦ 0V	0V	⑫ 0.6V	0.6V
④ 5V	5V	⑧ Same as at right		⑬ 0.6V	0.6V
				⑭ 5V	5V

27

Q202 (2SD637)

	Start	Stop
E	0V	0V
C	Same as at right	
B	Same as at right	

28

**SL-1700MK2/ SL-1700MK2/
SL-1710MK2 SL-1710MK2**

■ TONE ARM DRIVE CIRCUIT BOARD

Earth (Ground) Lines

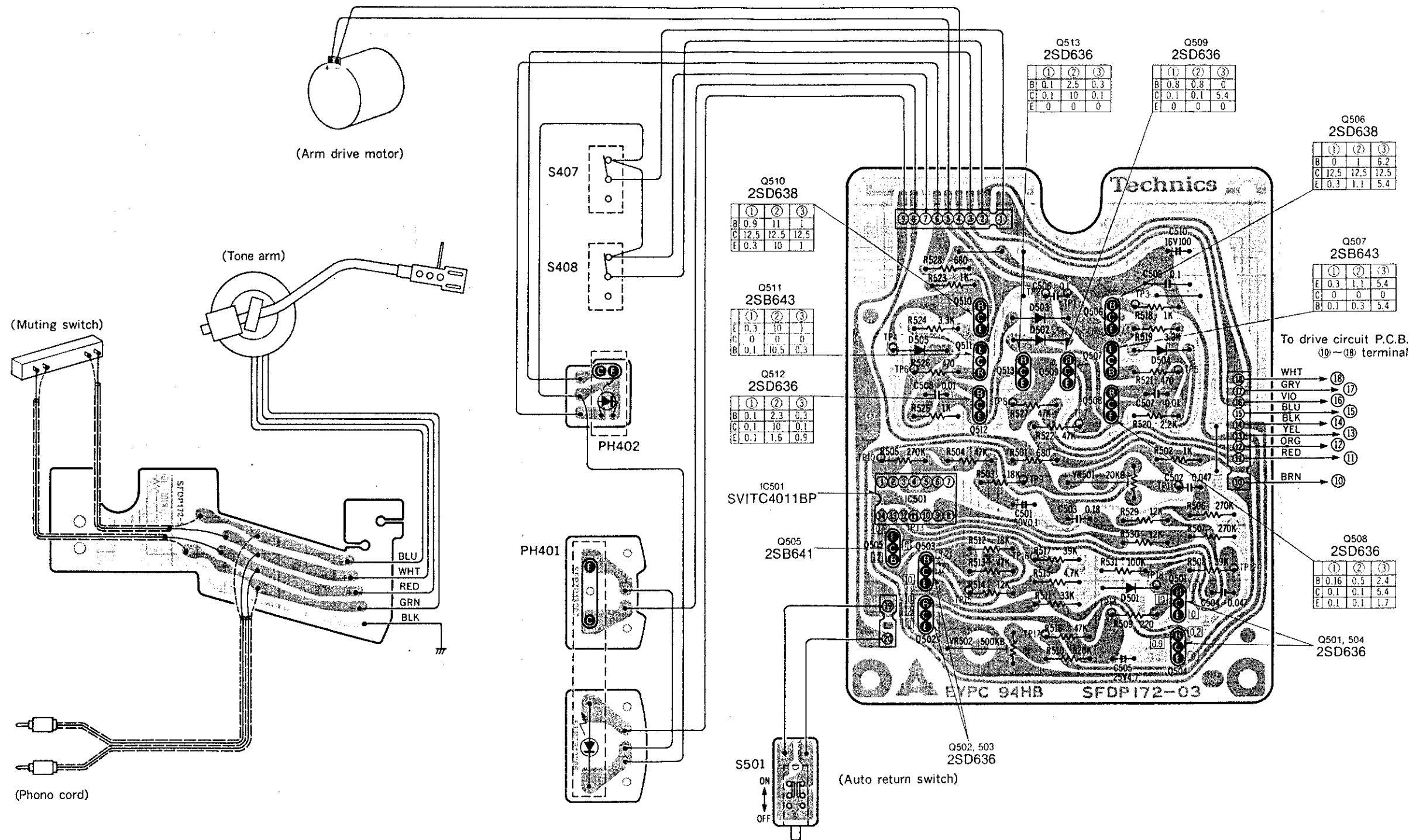

■ SCHEMATIC DIAGRAM 3 (Tone Arm Drive Circuit Board)

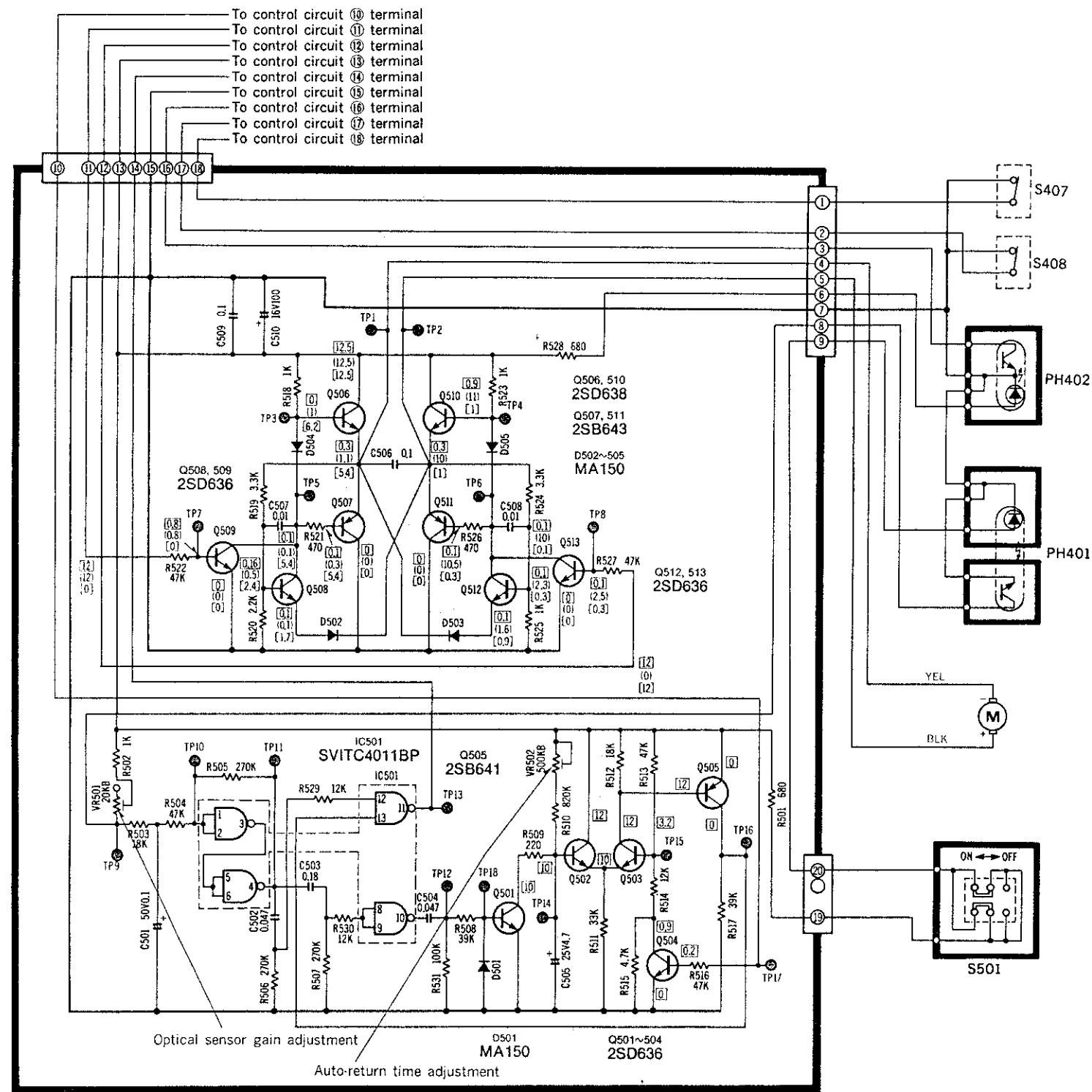

■ REFERENCE VOLTAGE AND WAVEFORM AT EACH IC

IC101 (AN6675)

	Start	Stop		Start	Stop		Start	Stop				
①	10V	1.7V		15V		⑱	Same as at right					
②	10V	1.7V										
③	0V	0V										
④	5V	1.7V										
⑤	5V	5V										
⑥	5V	6.6V										
⑦	0V	0V										
⑧	5V	5V										
⑨	0V	0V										
⑩		15V								15V	⑳	20V
⑪		15V										

IC201 (AN6680)

	Start	Stop		Start	Stop		Start	Stop																														
①	2.5V	2.5V		0V	0V	⑱	5V	2.5V																														
②	Same as at right								9V	9V	⑳	0V	0V																									
③	Same as at right													Same as at right		㉑	7V	0.14V																				
④	Same as at right																		0V	0V	㉒	0.4V	5.8V															
⑤	Same as at right																							0.2V	0.2V	㉓	1.5V	0.2V										
⑥	3.4V	3.4V																												8V	㉔	3V	3V					
⑦	0V	0V																																	8V		2.8V	2.8V

IC301 (AN6682)

	Start	Stop		Start	Stop		Start	Stop																				
①	Same as at right			Same as at right		⑧	Same as at right																					
②	Same as at right								0V	0V	⑨	9V	9V															
③	Same as at right													3.9V	3.9V	⑩												
																			Same as at right		⑪							
																								4μs	4μs	⑫		

**SL-1700MK2/ SL-1700MK2/
SL-1710MK2 SL-1710MK2**

EXPLODED VIEW (Main Base)

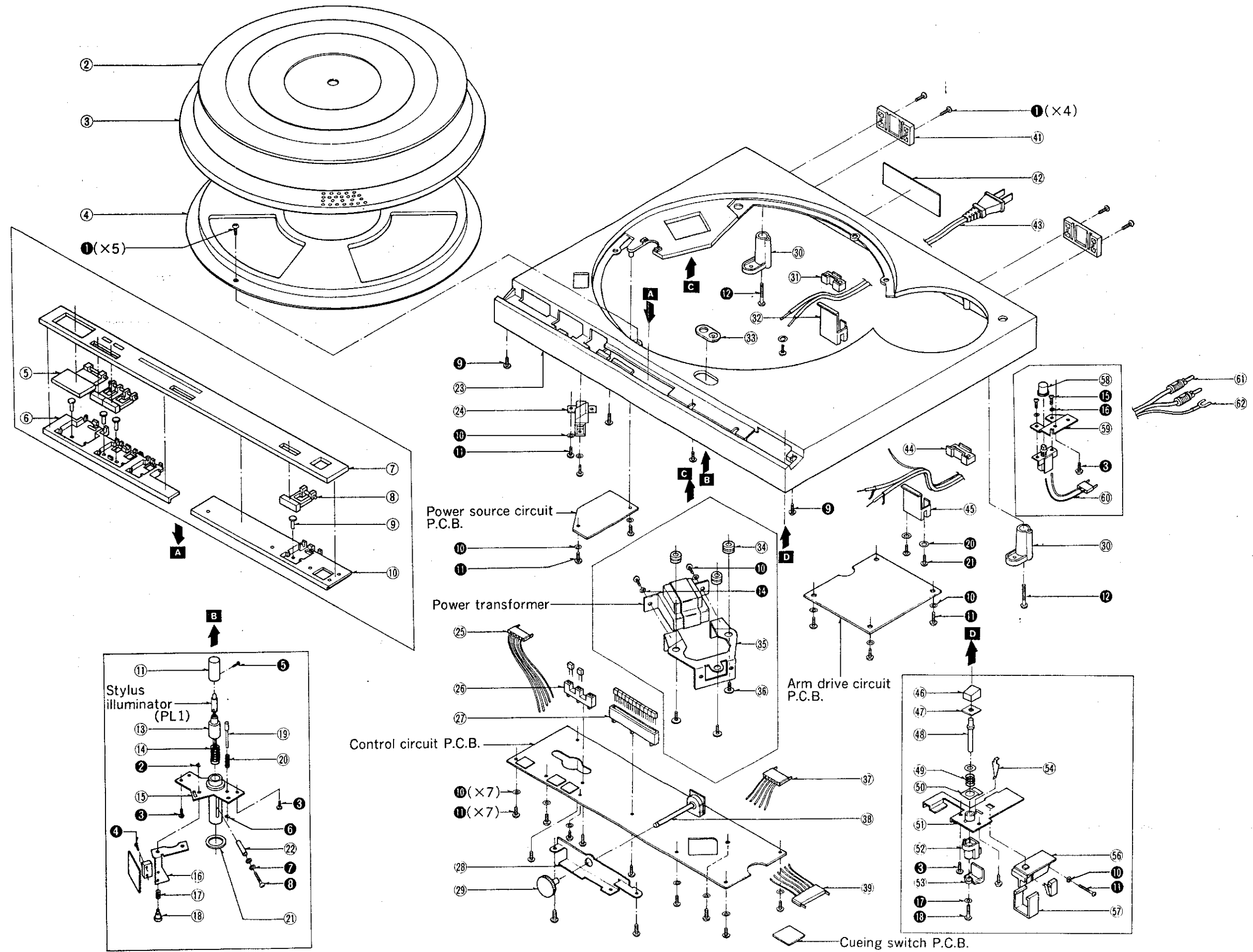

■ REPLACEMENT PARTS LIST (Main Base and Bottom Base Parts)

- Notes: 1. Part numbers are indicated on most mechanical parts.
Please use this part number for parts orders.
2. Δ indicates that only parts specified by the manufacture be used for safety.

SL-1700MK2(XG) → [XG] SL-1700MK2(XGF) → [XGF] SL-1700MK2(XGB) → [XGB]
 SL-1700MK2(E) → [E] SL-1700MK2(XA) → [XA] SL-1700MK2(XGE) → [XGE]
 SL-1700MK2A(XA) → [AXA] SL-1700MK2A(XG) → [AXG] SL-1700MK2A(E) → [AE]
 SL-1710MK2(XG) → [10XG] SL-1710MK2(E) → [10E] SL-1710MK2A(XG) → [10AXG]
 SL-1710MK2A(E) → [10AE]

Ref. No.	Part No.	Part Name & Description	Ref. No.	Part No.	Part Name & Description
CABINET and CHASSIS PARTS					
1	SFAD172-01E	Dust Cover	58	SFKT132-07	Knob, Auto Return Switch
2	SFTG172-01	Turntable Mat	59	SFUP172-10	Bracket, Auto Return Switch
3	SFTE172-01Z	Turntable	60	SFDJ172-04E	Connector, 3 Pin
4	SFUM172-05	Cover, Turntable	61	SFDH028-01	Phono Cord
5	SFKT172-02	Button, Start/Stop Switch	62	SFEL028-01E	Ground Wire
6	SFUM172-02	Bracket (A), Operation Panel	63	SFXGQ20-03	Screw, Stater Frame M'tg
7	SFUM172-01	Panel, Operation	64	SFMGQ20-01	Cover, Stater Frame Ass'y
8	SFKT172-03	Button, Speed Selector, Cueing Switch	65	SFMG520-31A	Stater Frame
9	SFUM172-11	Pin, Switch	66	SFMZ172-01E	FG Detector Coil Ass'y
10	SFUM172-03	Bracket (B), Operation Panel	67	SFMZQ20-01A	Shaft, Stater Frame Ass'y
11	SFKK172-01	Cover, Lamp	68	SFUP172-05	Bracket, Stater Frame M'tg Plate
13	SFXB172-02	Boss, Drive	69	SFUP172-08	Bracket, Drive P.C.B. Ass'y
14	SFQA172-01	Spring, Drive Boss	70	XVG4C30	Screw, Insulator (A) M'tg
15	SFUP172-01E	Plate Assembly, Stylus Illuminating Lamp	71	SFUM172-06	Insulator (A)
16	SFUP172-03	Plate, Lock Operation	72	SFXW172-01	Washer, Insulator (A)
17	SFQA001-02	Spring, Lock Operation Plate Pin	73	SFXW172-02	Washer, Insulator
18	SFXJ172-05	Pin, Lock Operation Plate M'tg	74	SFGA170-01	Rubber, Insulator
19	SFXJ172-01	Pin, Lock Canceler	75	SFQC170-01	Spring, Insulator
20	SFQA520-01	Spring, Lock Canceler Pin	76	SFXG170-02E	Nut, Insulator (A) M'tg
22	SFXO172-01	Pin, Guide	77	SFUP132-01	Cover, Power Transformer
23 [E, XG, XGB, XGF, AE, XGE, XA, AXA, AXG]	SFAC172-01	Cabinet (Silver)	78	SFUM172-12	Spacer, Clamper
23 [10E, 10XG, 10AE, 10AXG]	SFAC173-01	Cabinet (Black)	79	SFUM172-07	Insulator Cup
24	SFUM130-01	Cover, Neon	80	SFGA172-01	Insulator Rubber
25	SFDJ172-02E	Connector, 7 Pin	81	SFUM172-13	Spacer, Tone Arm
26	SFUM170-10	Spacer (A), Speed Selector LED	82	SFAU172-01	Bottom Board
27	SFUM172-09	Spacer (B), Speed Selector LED	83 [E, XG, XGF, XGB, AXA, XGE, XA, AE, AXG]	SFGK132-01	Cap, Rubber
28	SFUP172-06	Bracket, Pitch Control Knob Plate	83 [10E, 10XG, 10AXG, 10AE]	SFGK133S01	Cap, Rubber
29	SFKT172-04	Knob, Pitch Control	84	SFUZ172-01	Rubber Cushion, Insulator
30	SFAZ172-01	Supporter, Insulator	SCREWS, WASHERS and CIRCLIPS		
31	SFUM170-06	Spacer, AC Cord	①	XTN3+8BFZ	Screw
32	SFUM170-05	Clamper, AC Cord	②	XUC2FT	Circlip
33	SFUM172-04	Ornament, Stylus Illuminating Lamp	③	XTN3+8B	Screw
34	SFGC132-01	Spacer (Rubber), Power Transformer Bracket	④	XSN2+8	Screw
35	SFUP132-03	Bracket, Power Transformer	⑤	XSN17+3FY	Screw
36	SFXG132-02	Screw, Power Transformer Bracket M'tg	⑥	XUC25FT	Circlip
37	SFDJ172-01E	Connector, 6 Pin	⑦	XWA3B	Washer
38	SFUP172-09	Bracket, Volume Shaft	⑧	XSN3+14S	Screw
39	SFDJ172-03E	Connector, 9 Pin	⑨	XTV3+8GF	Screw
40	SFAT172-01A	Hinge Ass'y	⑩	XWG3	Washer
41	SFUM170-07	Case, Hinge Ass'y	⑪	XTB3+8BFN	Screw
42 [E, AE, 10AE]	SFNN172S01	Name Plate	⑫	XTN4+20J	Screw
42 [XG, XGF, XGB, AXA, XA, AXG]	SFNN172X01	Name Plate	⑬	XTN4+10B	Screw
42 [10E]	SFNN173S01	Name Plate	⑭	XWA4B	Washer
42 [10XG, 10AXG]	SFNN173X01	Name Plate	⑮	XSN3+8S	Screw
42 [XGE]	SFNN172G01	Name Plate	⑯	XWA3B	Washer
43	Δ RJA23ZC	AC Cord	⑰	XWA3B	Washer
43 [XGE]	Δ RJA45ZC	AC Cord	⑱	XSN3+10S	Screw
44	SFUM170-06	Spacer, Phono Cord	⑲	XWE3F8	Washer
45	SFUM170-11	Clamper Phono Cord	⑳	XTN3+12BFZ	Screw
46	SFKT172-01	Button, Power Switch	㉑	XTB3+8BFZ	Screw
47	SFUZ172-03	Spacer, Power Switch Button	㉒	XWG3	Washer
48	SFXJ172-03	Shaft, Power Switch Button	㉓	XTN3+8H	Screw
49	SFQA172-02	Spring, Power Switch	㉔	XTN3+8B	Screw
50	SFUP172-04	Supporter, Power Switch Plate	㉕	XWA3B	Washer
51	SFUP172-02E	Bracket, Power Switch M'tg Plate Assembly	㉖	XSN3+10S	Screw
52	SFUM001-11	Cam, Power Switch	㉗	XTN4+45B	Screw
53	SFUM132-07	Cam, Power Switch	㉘	XTN4+14GFZ	Screw
54	SFUP001-12	Bracket, Power Switch	㉙	XTB3+25BFN	Screw
56	SFUM132-05	Holder, Power Switch	㉚	XWG3	Washer
57	SFUM132-06	Holder, Power Switch	㉛	XTN3+8GFZ	Screw
			㉜	XTN4+25B	Screw

■ EXPLODED VIEW (Bottom Base)

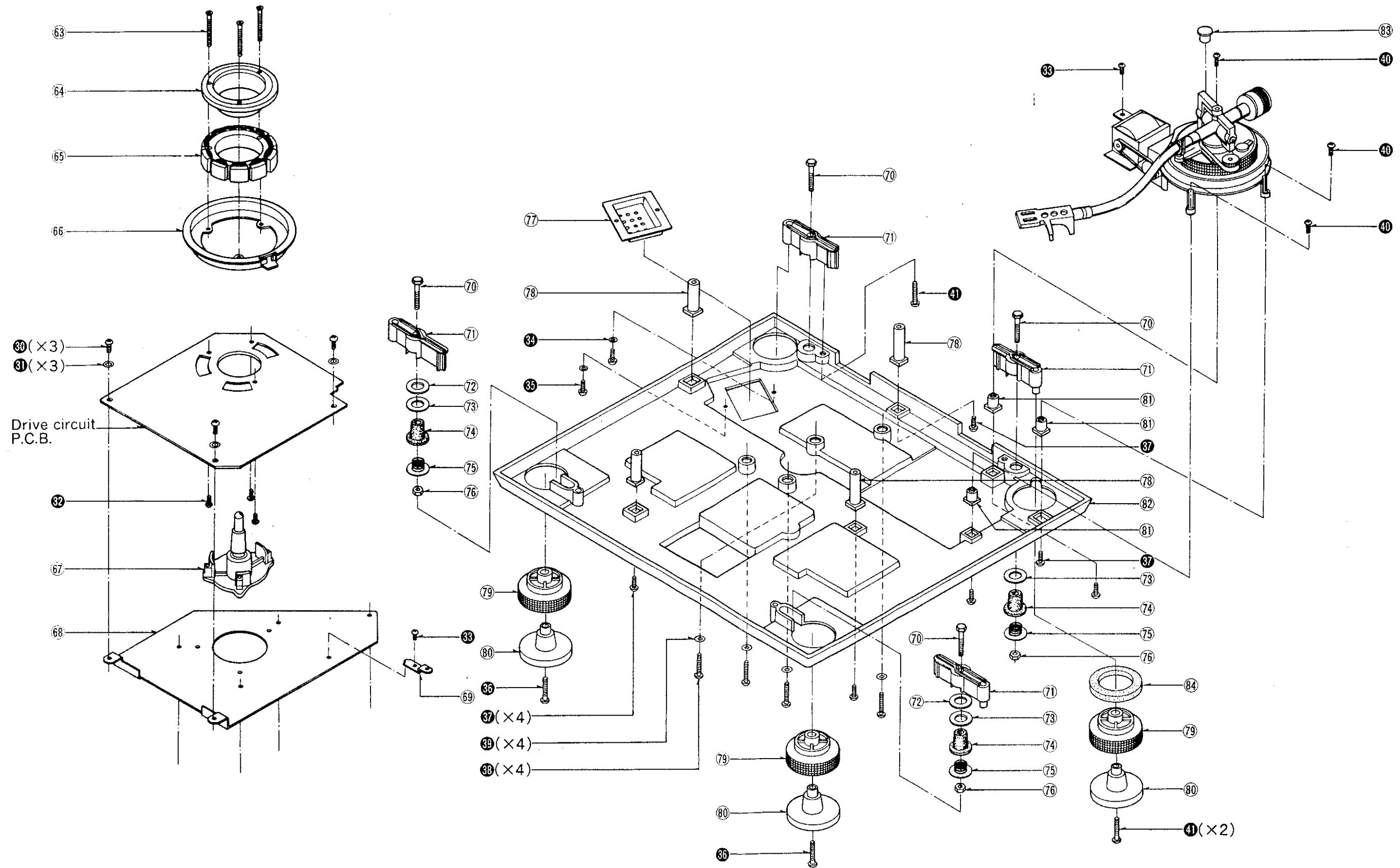

EXPLODED VIEW (Tone Arm and Arm Base)

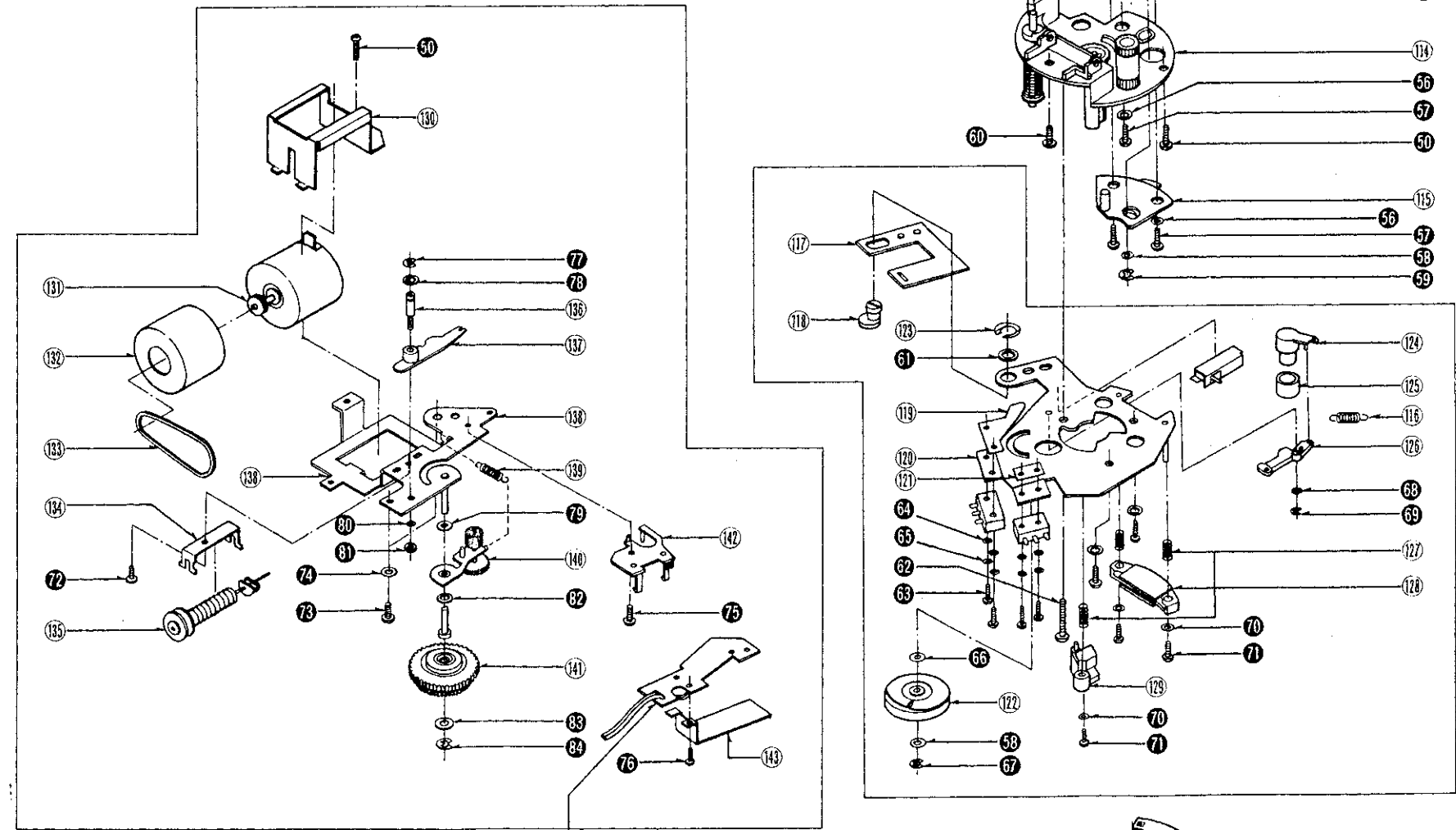
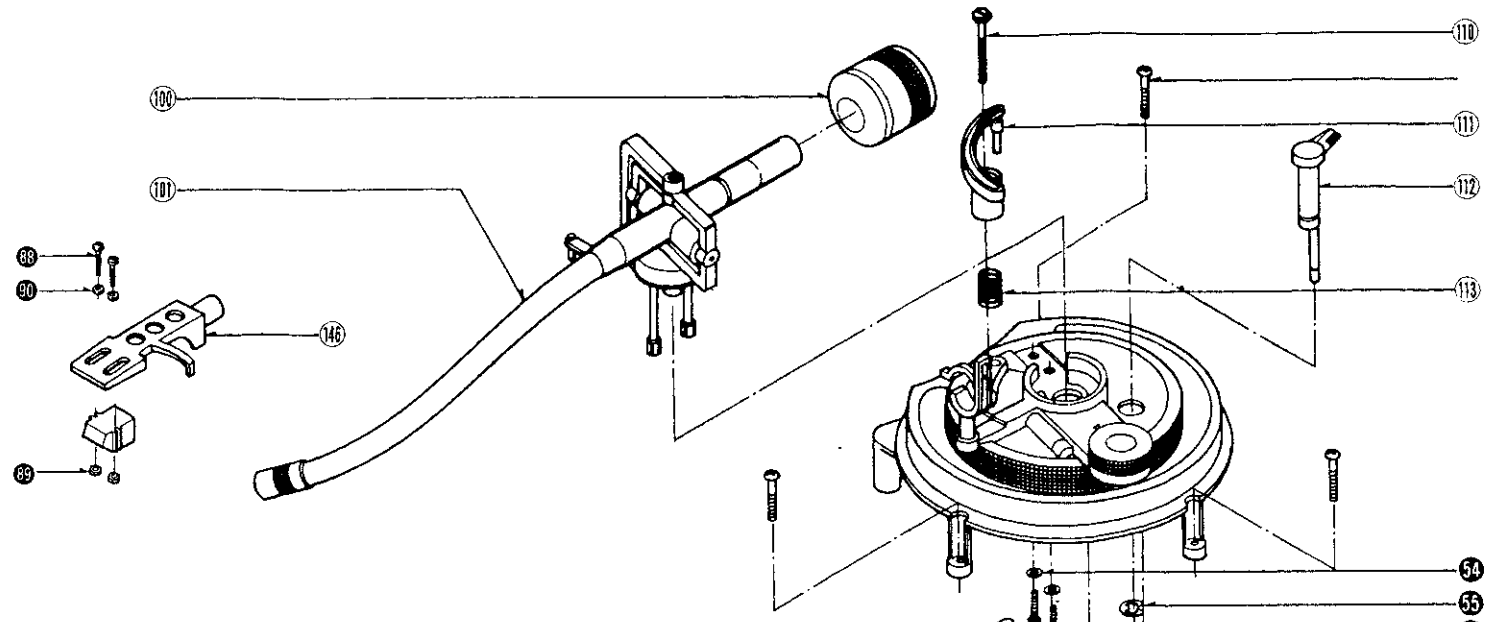
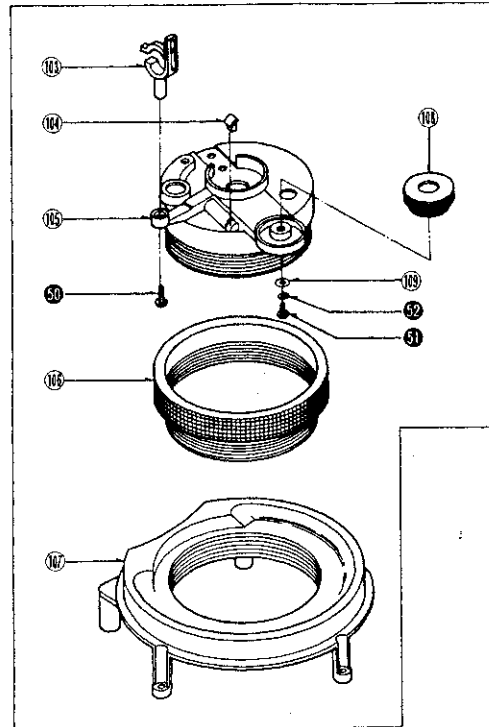

Ref. No.	Part No.	Part Name & Description
SCREWS, WASHERS and CIRCLIPS		
1	XTN3+8B	Screw
2	XTN26+6B	Screw
3	XWG26	Washer
4	XSN3+8S	Screw
5	XWA3B	Washer
6	XUC5FT	Circlip
7	XWG3	Washer
8	XTV3+6BFN	Screw
9	XWE4A10EW	Washer
10	XUC25FT	Circlip
11	XTV3+6BFN	Screw
12	XWG5E12BW	Washer
13	XTN3+25B	Screw
14	XSN23+12	Screw
15	XWE26BW	Washer
16	XWA26B	Washer
17	SFXW910-08	Washer
18	XUC3FT	Circlip
19	XWE3A6BC	Washer
20	XUC2FT	Circlip
21	XWE26BW	Washer
22	XSN26+6	Screw
23	XTN3+6B	Screw
24	XTV3+8BFN	Screw
25	XWG3	Washer
26	XTN3+8B	Screw
27	XTN3+12B	Screw
28	XUC3FT	Circlip
29	XWE4A10BW	Washer
30	XWE4A10EW	Washer
31	XWA3B	Washer
32	XNG3ES	Nut
33	SFXW172-55	Washer
34	XWE3A6BC	Washer
35	XUC2FT	Circlip
36	XWG3FZ	Washer
37	XWA3BFZ	Washer
38	XSN3+23BVS	Screw
39	SFCZV8801	Screw, Except Product for [E, XG, XGF, XGB, 10E, 10XG, XGE, XA]
40	SFPEW901	Nut, Except Product for [E, XG, XGF, XGB, 10E, 10XG, XGE, XA]
41	SFPEW901	Washer, Except Product for [E, XG, XGF, XGB, 10E, 10XG, XGE, XA]
42	[AXA, AE, AXG, 10AE, 10AXG] only	
43	[AXA, AE, AXG, 10AE, 10AXG] only	
44	[AXA, AE, AXG, 10AE, 10AXG] only	

PU output P.C.B.

REPLACEMENT PARTS LIST (Tone Arm and Arm Base Parts)

Note: Part number are indicated on most mechanical parts.
Please use this part number for parts orders.

SL-1700MK2(XG) → [XG] SL-1700MK2(XGF) → [XGF] SL-1700MK2(XGB) → [XGB]
 SL-1700MK2(E) → [E] SL-1700MK2(XA) → [XA] SL-1700MK2(XGE) → [XGE]
 SL-1700MK2A(XA) → [AXA] SL-1700MK2A(XG) → [AXG] SL-1700MK2A(E) → [AE]
 SL-1710MK2(XG) → [10XG] SL-1710MK2(E) → [10E] SL-1710MK2A(XG) → [10AXG]
 SL-1710MK2A(E) → [10AE]

Ref. No.	Part No.	Part Name & Description	Ref. No.	Part No.	Part Name & Description
TONE ARM and ARM BASE PARTS			ACCESSORIES		
100	SFPWG17201K	Balance Weight Ass'y	137	SFUP172-52E	Bracket
101 [E, XG, XGF, XGB, AXA, AE, XA, AXG, XGE]	SFPAM17201K	Tone Arm Ass'y (Silver)	138	SFUK172-51E	Bracket Arm
101 [10E, 10XG, 10AXG, 10AE]	SFPAM17202K	Tone Arm Ass'y (Black)	139	SFQH172-61	Spring
102 [E, XG, XGB, XGF, 10E, 10XG, XGE, XA, XGE]	SFPC31001K	Head Shell	140	SFUP172-51A	Bracket
102 [AXA, AE, AXG, 10AE, 10AXG]	SFPC31002K	Head Shell	141	SFUG172-62E	Base, Operation Gear Ass'y
103	SFPRT17201K	Arm Rest	142	SFUM172-61	Bracket, PU Output Cord
104 [10E, 10XG, 10AXG, 10AE]	SFPZB17206	Rubber, Lift Cap (Black)	143	SFUP172-56	Shield Case
104 [E, XG, XGF, XGB, AXA, AE, AXG, XGE]	SFPZB17205	Rubber, Lift Cap (Silver)	144	SFUM172-60A	Tone Arm Fixing Plate Ass'y
105 [10E, 10XG, 10AXG, 10AE]	SFPKD17205	Arm Base (Black)	145	SFDJ172-05E	Socket, 9 Pin
105 [E, XG, XGF, XGB, AXA, AE, AXG, XGE]	SFPKD17203	Arm Base (Silver)	146 [AXA, AE, AXG, 10AE, 10AXG] only	EPC207CK	Cartridge, Except Product for [E, XG, XGF, XGB, 10E, 10XG, XGE, XA]
106	SFPKB17201S	Ring, Operation	PACKINGS		
107	SFPKD17201	Bracket, Arm Base	P1 [E, XG, XGB, AXA, XGE, XA]	SFHP172M01	Carton
108	SFPAB17206	Knob, Anti-skate Force Control	P1 [10E, 10XG]	SFHP173S01	Carton
109	SFPEW17201	Washer, Anti-skate Force Control Knob	P1 [XGF]	SFHP172C01	Carton
110	SFXG829-1	Screw, Tone Arm Lift Adjustment	P1 [10AXG, 10AE]	SFHP173Q01	Carton
111	SFPRT17202K	Lift Ass'y	P1 [AE, AXG]	SFHP172A01	Carton
112	SFPZB17202	Knob, Arm Base Lock	P2	SFHH172-01	Pad, Front
113	SFOA829-03	Spring, Lift Ass'y	P3	SFHH172-02	Pad, Rear
114	SFPAB17201K	Rift Ass'y	P4	SFHD172-01	Pad, Top
115	SFPZB17203K	Plate, Position Fix	P5	SFHD172-02	Pad, Turntable
117	SFUM172-58	Base, Muting Switch	P6	SFYH60X60	Polyethylene Cover, Turntable Unit
118	SFXJ172-60	Shaft, Operation	P7	SFYH60X60	Polyethylene Cover, Dust Cover
119	SFUP172-60	Bracket, Switch Adjustment Plate	P8	SFYH40X45	Polyethylene Cover, Turntable
120	SFUK172-52E	Movable Base Assembly	P9 [E, AE, 10E, 10AE]	SFNU172S01	Instruction Book, Printed Matter
121	SFUP172-59	Bracket, Switch Adjustment Plate	P9 [XG, XGF, XGB, AXA, 10XG, 10AXG, AXG, XA]	SFNU172X01	Instruction Book, Printed Matter
122	SFUM172-56	Cam, Lift	P9 [XGE]	SFNU172G01	Instruction Book, Printed Matter
123	SFXW130-01	Clip, Muting Switch Base			
124	SFUM172-57	Lever, Brake			
125	SFGT172-51	Tube, Rubber			
126	SFUM172-56	Lever, Muting			
127	SFQA172-52	Spring, Base Supporter Assembly			
128	SFPZB17251	Base, Supporter Assembly			
129	SFUM172-59	Rest, Sensor Assembly			
130	SFUP172-55	Bracket, Motor Assembly			
131	SFMH172-51E	Motor Assembly			
132	SFGZ172-52	Cover, Motor			
133	SFGB172-51	Belt			
134	SFUP172-58	Bracket, Worm Assembly			
135	SFUG172-53E	Worm Assembly			
136	SFXJ172-52	Shaft			