

Service Manual

Direct Drive Automatic Turntable System

Revise**SL-7**[E], [EK], [XL],
[EB], [EG], [EF], [XA]**SL-7(K)**[E], [EK], [XL],
[EB], [EG], [XA]

* The colors of this model include silver and Black. The black type model is provided with (K) in the Service Manual.

Areas

- * [E] is available in Scandinavia.
- * [EK] is available in United Kingdom.
- * [XL] is available in Australia.
- * [EB] is available in Belgium.
- * [EG] is available in European.
- * [EF] is available in France.
- * [XA] is available in Asia, Latin America, Middle East and Africa.

NOTES:

1. This revised service manual includes the points of change from SL-7/K service manual (Order No. SD8009-1781), and the related printed circuit board diagram and adjusting method.
2. For the servicing of Model SL-7, use this revised service manual.
3. SL-7/K service manual (Order No. SD8009-1781) must be disused.

SPECIFICATIONS

Specifications subject to change without notice.
Weight and dimensions shown are approximate.

General

Power supply:	~ 110-120/220-240V, 50/60 Hz DC 12V (DC input jack)
Power consumption:	20 W (AC) 6W (DC)
Dimensions: (W x H x D)	31.5 x 8.8 x 31.5 cm (12-1/2" x 3-1/2" x 12-1/2")
Weight:	7 kg (15.4 lbs.)

Turntable section

Type:	Quartz direct drive Automatic turntable Auto start/Auto lead-in Auto return Auto stop Repeat play Auto speed select Auto size select 2-speed search functions Record presence detection
Drive method:	Direct drive
Motor:	Brushless DC motor
Drive control method:	Quartz-phase-locked control

Turntable platter:	Aluminum die-cast Diameter 30 cm (12 inches)
Turntable speeds:	33-1/3 rpm and 45 rpm Auto speed select (Manual selection possible)
Speed deviation:	within $\pm 0.002\%$
Wow and flutter:	0.012% WRMS* 0.025% WRMS (JIS C5521) $\pm 0.035\%$ peak (IEC 98A Weighted)

* Measured by obtaining signal from built-in frequency generator of motor assembly.

Rumble:	-56 dB (IEC 98A Unweighted) -78 dB (IEC 98A Weighted)
----------------	--

Tonearm section

Type:	Dynamic balanced type Linear tracking tonearm 4-pivot gimbal suspension
Effective length:	10.5 cm (4-1/8")
Tracking error angle:	Within $\pm 0.1^\circ$
Effective mass:	9 g (including cartridge)
Resonance frequency:	12 Hz
Tonearm drive motor:	Coreless DC motor

■ Cartridge section

Type:	Moving magnet stereo cartridge One point suspension system
Magnet:	Samarium cobalt (Sm-Co)
Cantilever:	Pure boron pipe
Magnetic circuit:	All laminated core
Frequency response	10 Hz to 50 kHz 20 Hz to 35 kHz \pm 3 dB 20 Hz to 10 kHz \pm 1 dB
Output voltage:	2.5 mV at 1 kHz 5 cm/s. zero to peak lateral velocity (7 mV at 1 kHz, 10 cm/s. zero to peak 45° velocity [DIN 45 500])

Channel separation:	More than 22 dB at 1 kHz
Channel balance:	Within 1.8 dB at 1kHz
Recommended load impedance	47 k Ω ~ 100 k Ω
Compliance (dynamic):	12 x 10 ⁻⁶ cm/dyne at 100 Hz
Vertical tracking angle:	20°
Stylus pressure range:	1.25 \pm 0.25 g (12.5 \pm 2.5mN)
Stylus tip:	0.3 x 0.7 mil (7.5 x 18 μ m) Elliptical stylus
Weight:	6.0 g (cartridge only)
Replacement stylus:	EPS-202ED

TECHNISCHE DATEN

Änderungen der technischen Daten vorbehalten.

Die angegebenen Gewichts- und Abmessungsdaten sind circa Werte.

■ Allgemeine Daten

Stromversorgung:	~ 110-120/220-240V, 50/60 Hz Wechselstrom 12V Gleichstrom (Ausgestattet mit Gleichstrom-Eingangsbuchse)
Leistungsaufnahme:	20 W (Wechselstrom) 6 W (Gleichstrom)
Abmessungen (B x H x T):	31.5 x 8.8 x 31.5 cm
Gewicht:	7 kg

■ Plattenspieler

Type:	Quarz-Direktantrieb Automatischer Plattenspieler Auto-Start/Auto-Zuführung Rückführautomatik Stop-Automatik Wiederhol-Betrieb Automatische Drehzahlwahl Automatische Plattengrößewahl 2-Geschwindigkeiten- Suchfunktionen Plattenpräsenz-Registrierung
Antrieb:	Direktantrieb
Motor:	Kollektorloser Gleichstrommotor
Antriebsregel-Methode:	Quarz-Steuerung (QPL)
Plattenteller:	Aluminium-Druckguß Durchmesser 30 cm
Plattenteller- Drehzahlen:	33-1/3 und 45 U/min Automatische Drehzahlwahl (manuelle Wahl möglich)
Drehzahlabweichung:	Innerhalb \pm 0.002%
Gleichlaufschwankungen:	0.012% WRMS* 0.025% WRMS (JIS C5521) \pm 0.035% Spitze (IEC 98A bewertet)

* Gemessen anhand von Signalen vom eingebauten Frequenz-generator des Motorbauteils.

Rumpel-Fremdspannungsabstand:	-56 dB (IEC 98A unbewertet)
Rumpel-Geräuschspannungsabstand:	-78 dB (IEC 98A bewertet)

■ Tonarm

Typ:	Dynamisch ausbalancierter Tangential-Tonarm mit Kardan- aufhängung mit 4-Punkt-Drehlager
Effektive Länge:	105 mm
Spurfehlwinkel:	Innerhalb \pm 0.1°
Effektive Masse:	9 g (einschließlich Tonabnehmer)
Resonanzfrequenz:	12 Hz
Tonarm-Antriebsmotor:	Kernloser Gleichstrommotor

■ Tonabnehmer

Typ:	Stereo-Magnet-Tonabnehmer mit Einpunkt-Aufhängungssystem
Magnet:	Samarium-Kobalt (SM-Co)
Nadelträger:	Röhre aus reinem Bor
Magnetkreis:	Ganzlamellenkern
Frequenzgang:	10 Hz bis 50 kHz 20 Hz bis 35 kHz \pm 3 dB 20 Hz bis 10 kHz \pm 1 dB
Ausgangsspannung:	2.5mV bei 1 kHz 5 cm/s. Null-zu-Spitze, lateral (7 mV bei 1kHz 10cm/s. Null-zu- Spitze, 45° [DIN 45 500])
Kanalsternung:	Mehr als 22 dB bei 1kHz
Kanalabweichung:	Innerhalb 1.8 dB bei 1 kHz
Empfohlene Endimpedanz:	47k Ω ~ 100k Ω
Nachgiebigkeit (dynamisch):	12 x 10 ⁻⁶ cm/dyn bei 100 Hz
Vertikaler Spurwinkel:	20°
Auflagekraft- Einstellbereich:	1.25 \pm 0.25 g (12.5 \pm 2.5mN)
Nadelspitze:	0.3 x 0.7 Mil (7.5 x 18 μ m) Elliptisch geschliffene
Gewicht:	6.0 g (nur Tonabnehmer)
Ersatznadel:	EPS-202ED

SPECIFICATIONS

Les spécifications sont susceptibles d'être modifiées sans préavis.
Le poids et les dimensions donnés sont approximatifs.

■ Généralités

Alimentation:	Alternatif 110-120/220-240V, 50/60 Hz 12V C.C. (Equipée d'un jack d'entrée C.C.)
Consommation:	20 W (C.A.) 6 W (C.C.)
Dimensions: (L x H x P)	31.5 x 8.8 x 31.5 cm
Poids:	7 kg

■ Platine de lecture

Type:	Entraînement direct à quartz Platine automatique Départ automatique/Entrée automatique Retour automatique Arrêt automatique Audition répétée Sélecteur de vitesse automatique Sélecteur de diamètre automatique Fonctions exploratrices à 2 vitesses Détection de la présence d'un disque
--------------	--

Système d'entraînement:

Entraînement direct

Moteur:

Moteur C.C. sans balai

Groupe de réglage:

Réglage d'accrochage de phase
par quartz

Plateau de lecture:

Aluminium moulé sous pression
Diamètre 30 cm

Vitesses de rotation:

33-1/3 et 45 t/p.m.
Sélecteur de vitesse automatique
(Sélection manuelle possible)

Déviations de la vitesse:

En deçà de $\pm 0.002\%$

Pleurage et scintillement:

0.012% de valeur efficace*
0.025% de valeur efficace
(JIS C5521)
 $\pm 0.035\%$ de crête
(IEC 98A Pondéré)

* Mesuré par l'obtention d'un signal provenant du générateur de fréquences incorporé de l'ensemble du moteur.

Ronflement:	-56 dB (IEC 98A Non pondéré) -78 dB (IEC 98A Pondéré)
--------------------	--

■ Bras de lecture

Type:	Bras de lecture d'alignement linéaire de type à équilibre dynamique avec suspension à la cardan à 4 pivots
Longueur effective:	105 mm
Angle d'erreur de piste:	En deçà de $\pm 0.1^\circ$
Masse réelle:	9 g (y compris la cellule pick-up)
Fréquence de résonance:	12 Hz
Moteur d'entraînement du bras de lecture:	Moteur sans noyau C.C.

■ Cellule pick-up

Type:	Cellule pick-up stéréo à aimant mobile Système de suspension ponctuelle Samarium-Cobalt (SM-Co)
Aimant:	Tube à bore pur
Porte-à-faux:	Noyau entièrement feuilleté
Circuit magnétique:	10 Hz à 50 kHz
Réponse en fréquence:	20 Hz à 35 kHz ± 3 dB 20 Hz à 10 kHz ± 1 dB
Tension de sortie:	2.5 mV à 1 kHz; 5 cm/s. zéro à vitesse latérale de crête (7 mV à 1 kHz; 10 cm/s., zéro à vitesse 45° de crête [DIN 45 500])
Séparation de canal:	Plus de 22 à 1 kHz
Equilibrage des canaux:	En deçà de 1.8 dB à 1 kHz
Impédance de charge recommandée:	47k Ω ~ 100k Ω
Elasticité (dynamique):	12 x 10 ⁻⁶ cm/dyne à 100 Hz
Angle d'alignement vertical	20°
Plage de la force verticale:	1.25 \pm 0.25 gramme (12.5 \pm 2.5mN)
Extrémité de la pointe de lecture:	0.3 x 0.7 mil (7.5 x 18 μ m) Forme elliptique
Poids:	6.0 grammes (cellule seule)
Remplacement de la pointe de lecture	EPS-202ED

■ CONTENTS

	Page
LOCATION OF CONTROLS	4, 5
FEATURES	6
DISASSEMBLY INSTRUCTIONS	7 ~ 10
DESCRIPTION OF CONNECTOR	11
REPLACEMENT OF HALL ELEMENT	11
ADJUSTMENT (ENGLISH)	12 ~ 14
JUSTIERUNG (DEUTSCH)	15, 16

	Page
REGLAGES (FRANÇAIS)	17, 18
REPLACEMENT PARTS LIST	19, 20, 29, 30
BLOCK DIAGRAM	21, 22
PRINTED CIRCUIT BOARD WIRING VIEW	23, 24
EXPLODED VIEWS	25, 26, 30
SCHEMATIC DIAGRAM	27, 28
BLOCK DIAGRAM OF IC'S	31
CHANGES	31, 32

■ LOCATION OF CONTROLS

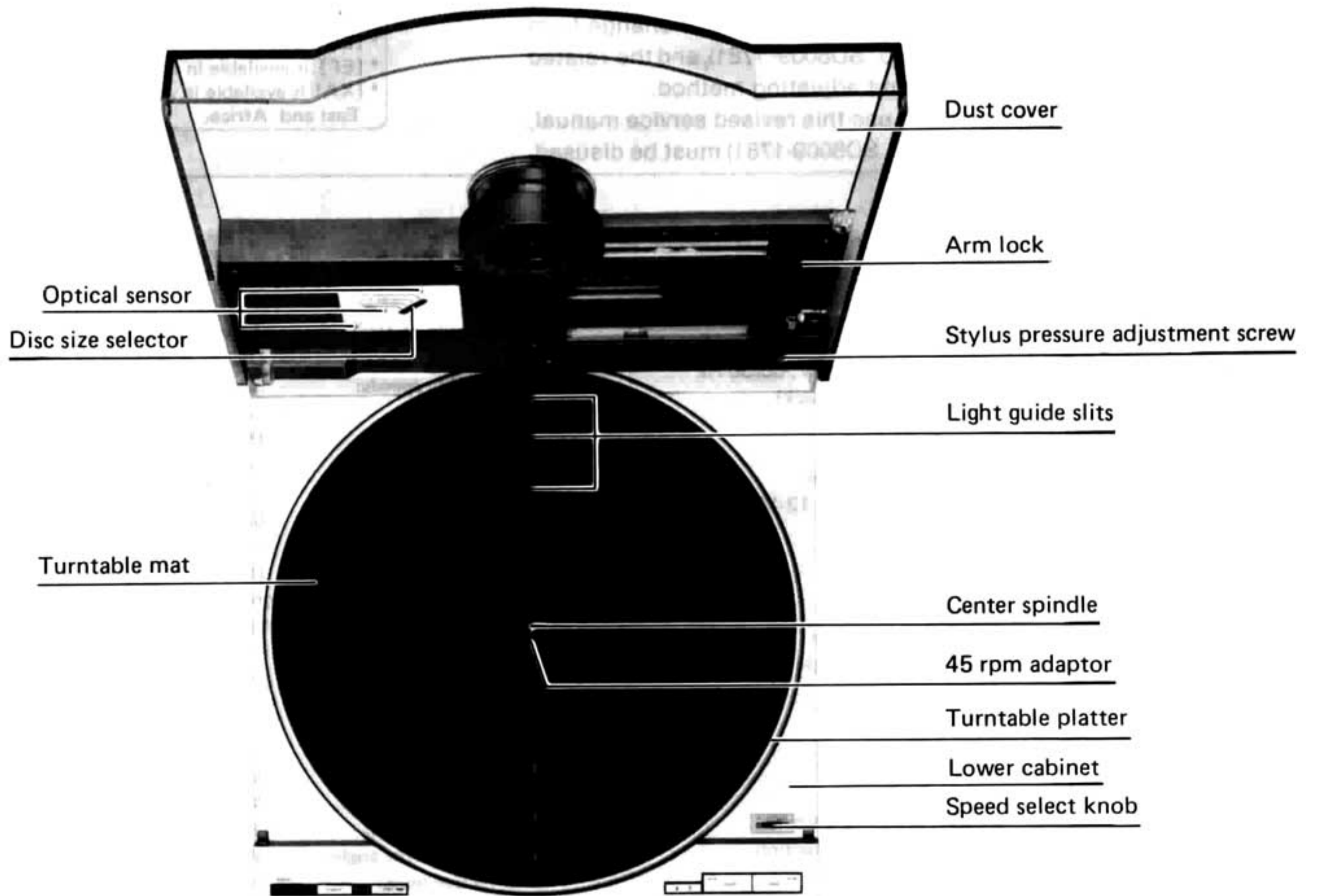
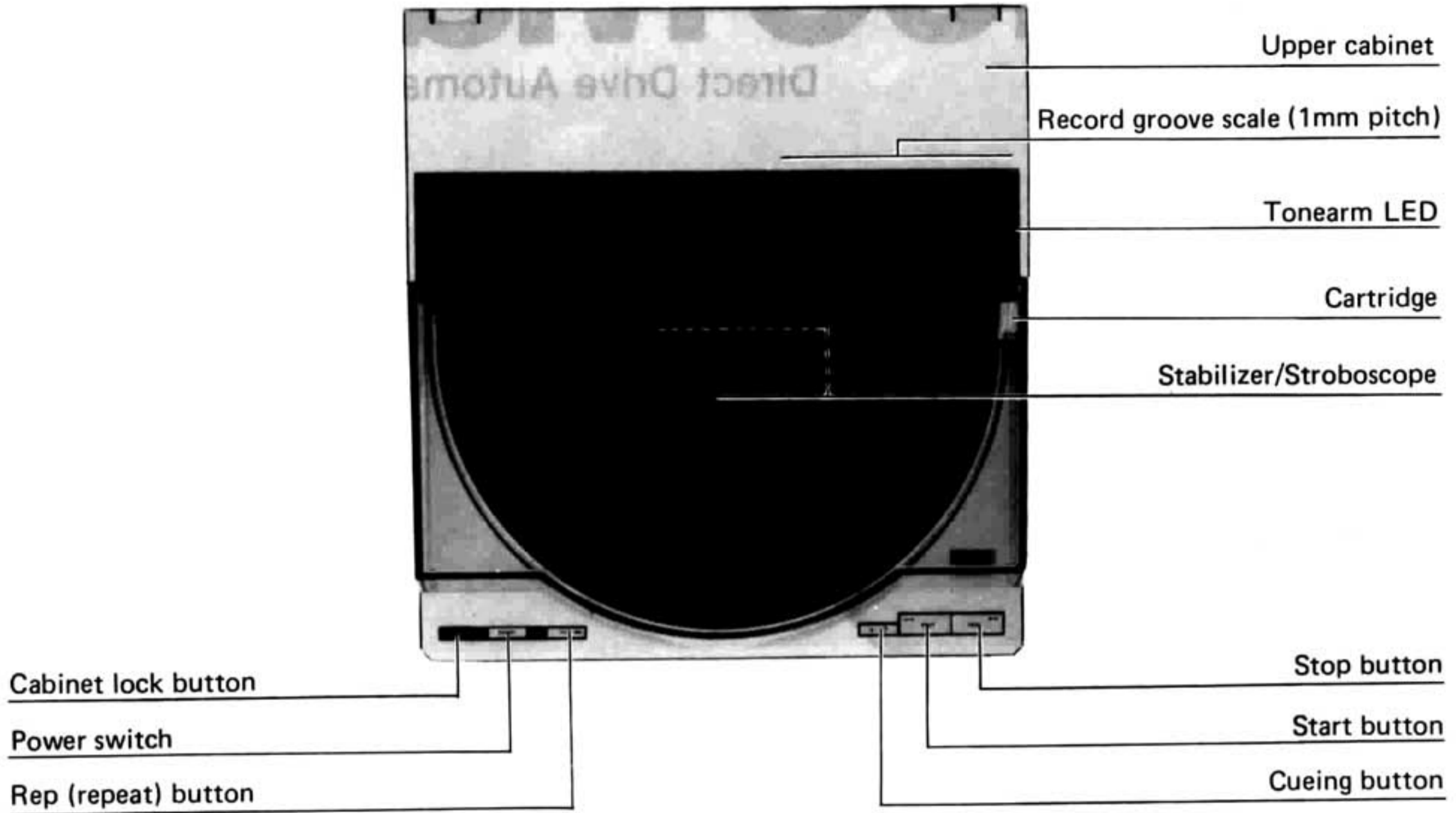

Hinge



Phono Cord

Insulator

AC Cord

DC input jack (for DC power supply)

Power select switch (S3)

Power switch (S1-1, 1-2)

Power P.C.B.

Power transformer (T1)

Cover switch (S305)

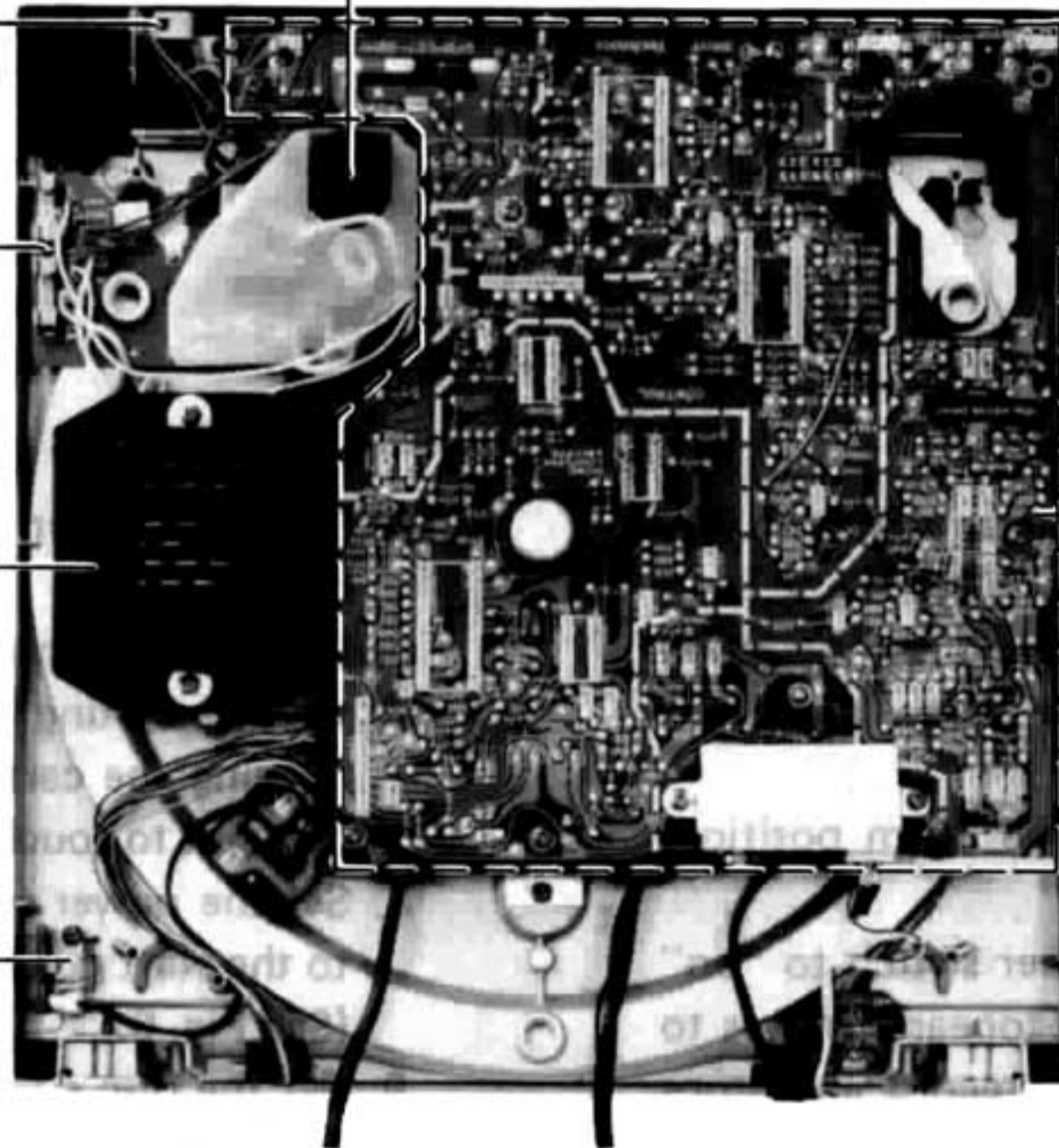

Main P.C.B.

End detect switch (S307)

Rest detect switch (S306)

Record size select shutter

Arm drive drum

Arm drive motor

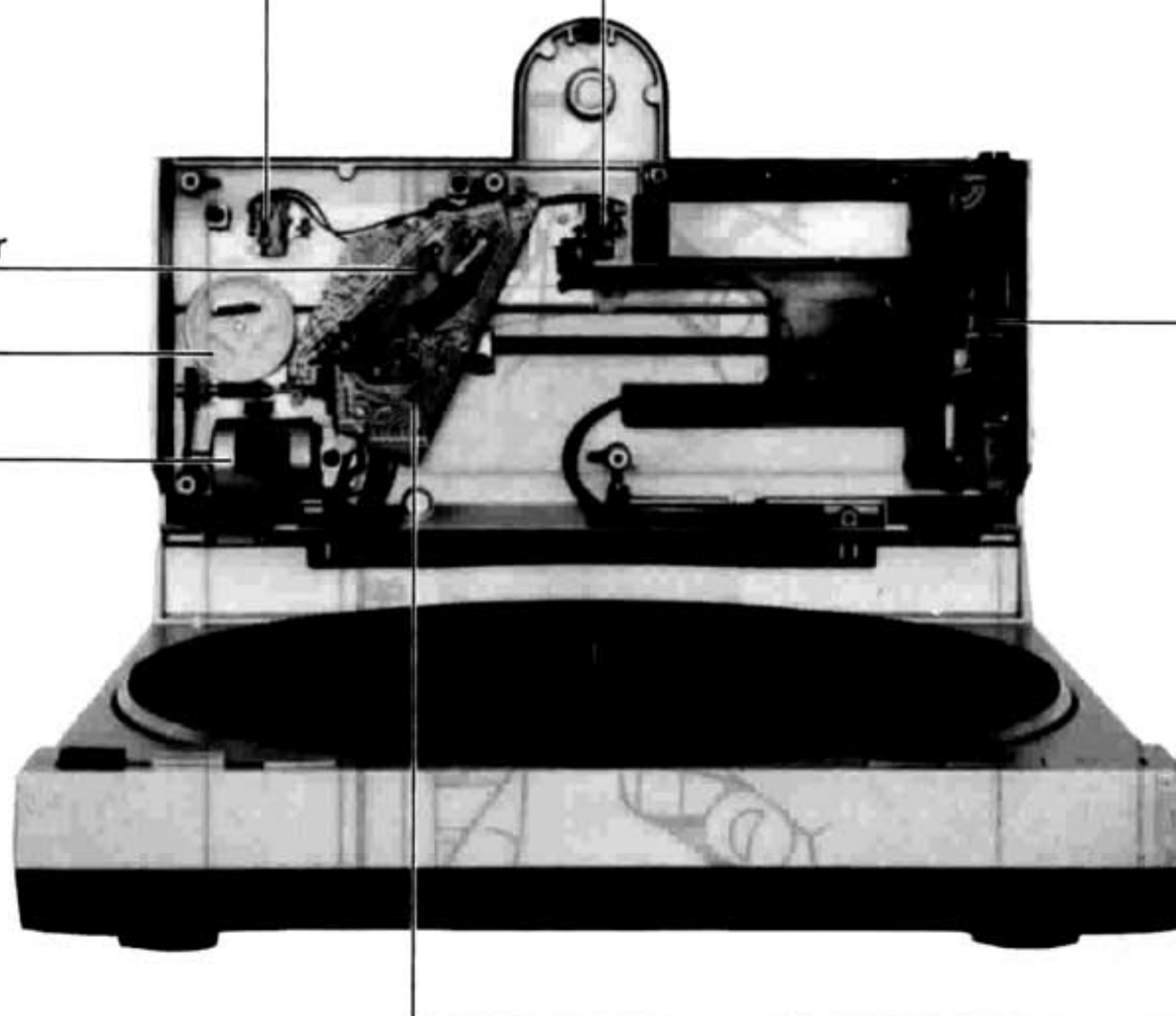

Tonearm

Disc size sensor P.C.B.

■ FEATURES

1. High performance direct drive unit the size of a record jacket

The SL-7 consists of an upper and lower cabinet. The upper cabinet is made of precision aluminum diecast to assure a high degree of accuracy and includes the linear tracking tonearm, tracking control circuitry and optical sensor.

The lower cabinet, made of zinc diecast to give the unit sufficient mass, holds Technics' original integral rotor/platter direct drive motor and its control circuitry. It's hard to believe that it all fits in a unit the size of a record jacket.

2. Just put on a record and press the start button.

Thanks to the optical sensor and microcomputer, both record size and record speed are detected automatically so all you have to do is press the start button to begin play.

At the end of the record, the tonearm automatically rises and returns to the start position.

When there is no record on the turntable, the tonearm does not move, so there is no danger of harming the stylus accidentally.

3. Dynamic balanced linear tracking tonearm employs optical sensor and groove deflection angle detection for extremely stable and accurate tracking

The linear tracking tonearm moves across the record surface in the same way as the cutter head used to make the record in the first place. Therefore there is virtually no tracking error or skating force.

Located by the stylus is an optical sensor that detects tracking conditions by means of groove deflection angle. Based on this information, tonearm movement is controlled to maintain optimum tracking at all times.

Because the tonearm is dynamically balanced, the turntable can be played horizontally or vertically.

4. Complete multi-function control capability.

Besides the simple, basic operating procedure described above, you also have complete selective control over all tonearm and turntable functions.

5. A precision coreless DC motor is used for tonearm drive to assure quiet and accurate control.

The coreless DC motor and slide bearing of minimum friction assure extremely precise tonearm movement. A 4-point pivot bearing gimbal suspension developed by Technics reduces friction and raises sensitivity while contributing to smooth tracking ability.

6. MM cartridge with pure boron pipe cantilever and excellent physical characteristics for faithful sound reproduction

The SL-7 is equipped with the Technics developed EPC-100CMK2 cartridge with pure boron pipe cantilever, the first in the world. Boron greatly reduces the effective mass of the moving system while the one-point suspension system provides an accurately defined point of support. Technics original cartridge technology is employed throughout this cartridge to give you the rich, realistic sound you've always wanted.

7. Other advanced features:

- Technics' original integral rotor-platter structure combines motor rotor and platter for more stable performance.
- Full cycle detection FG servo with quartz phase locked control assures unbeatable rotational accuracy.
- Dial scale and tonearm LED indicator on outside of upper cabinet make it easy to check on tonearm position.
- Record stabilizer and stroboscope built-in.
- 45 rpm single-play adaptor is located in turntable platter for pop-up convenience.
- Can be run on either AC or DC (12V) current. DC adaptor optionally available for car battery use.

■ DISASSEMBLY INSTRUCTIONS

How to remove the bottom board and main P.C.B.

1. Turn over the unit and put it on a soft cloth cushion or the like so as not to damage the cabinet or the dust cover.
2. Remove the setscrews ① ~ ④ of the insulator and bottom board. Then the bottom board can be removed. (See photo 1.)
3. Remove the rear cover setscrews ⑤ and ⑥ to remove the rear cover. (See photo 2.)
4. Remove the setscrews ⑦ ~ ⑮ and connectors ⑯ ~ ⑰ of the main P.C.B.. Then the main P.C.B. can be removed. (See photo 3.)

*When installing the main P.C.B. on the unit, make sure that the connector ⑱ (CN102) is engaged with the pin of the stator from.



Photo 1

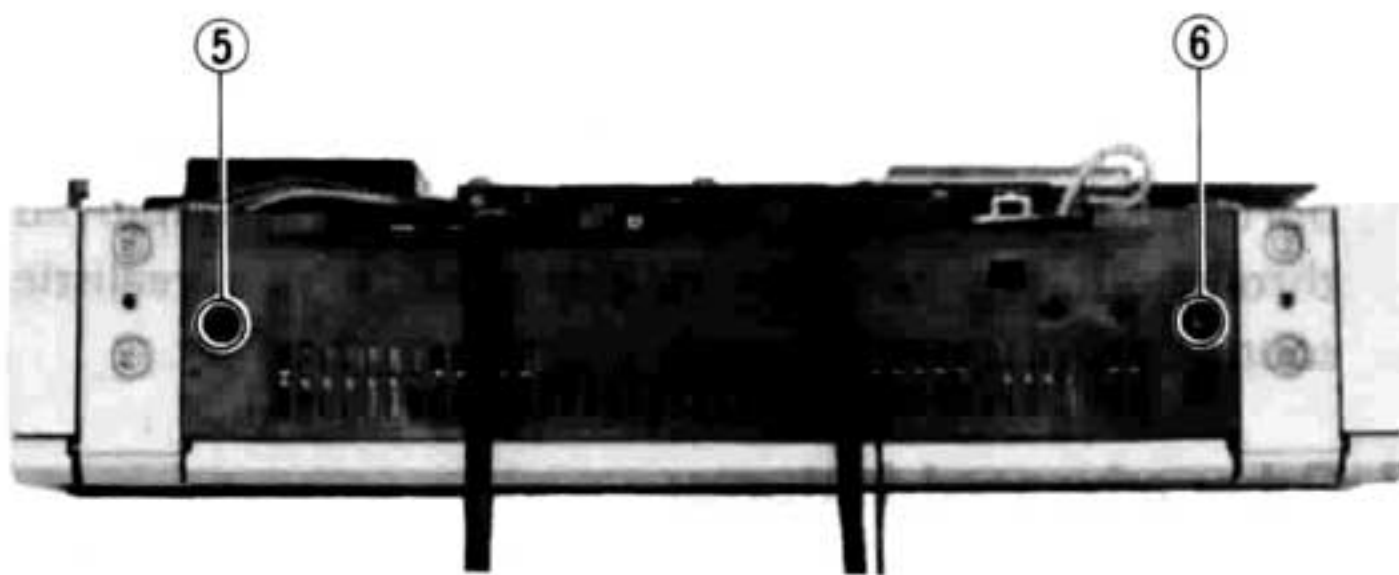

Photo 2

How to remove the turntable

1. Holding the turntable by hand, remove the adapter 45 by turning it counterclockwise. (See photo 4.)
2. Remove the nut ⑳, washers ㉑ and ㉒ used to secure the turntable. (See Fig. 1.)
3. Set 3mm screw into the two holes provided near the center spindle of the turntable, and then lift the screws with both hands to remove the turntable. (See Fig. 1.)

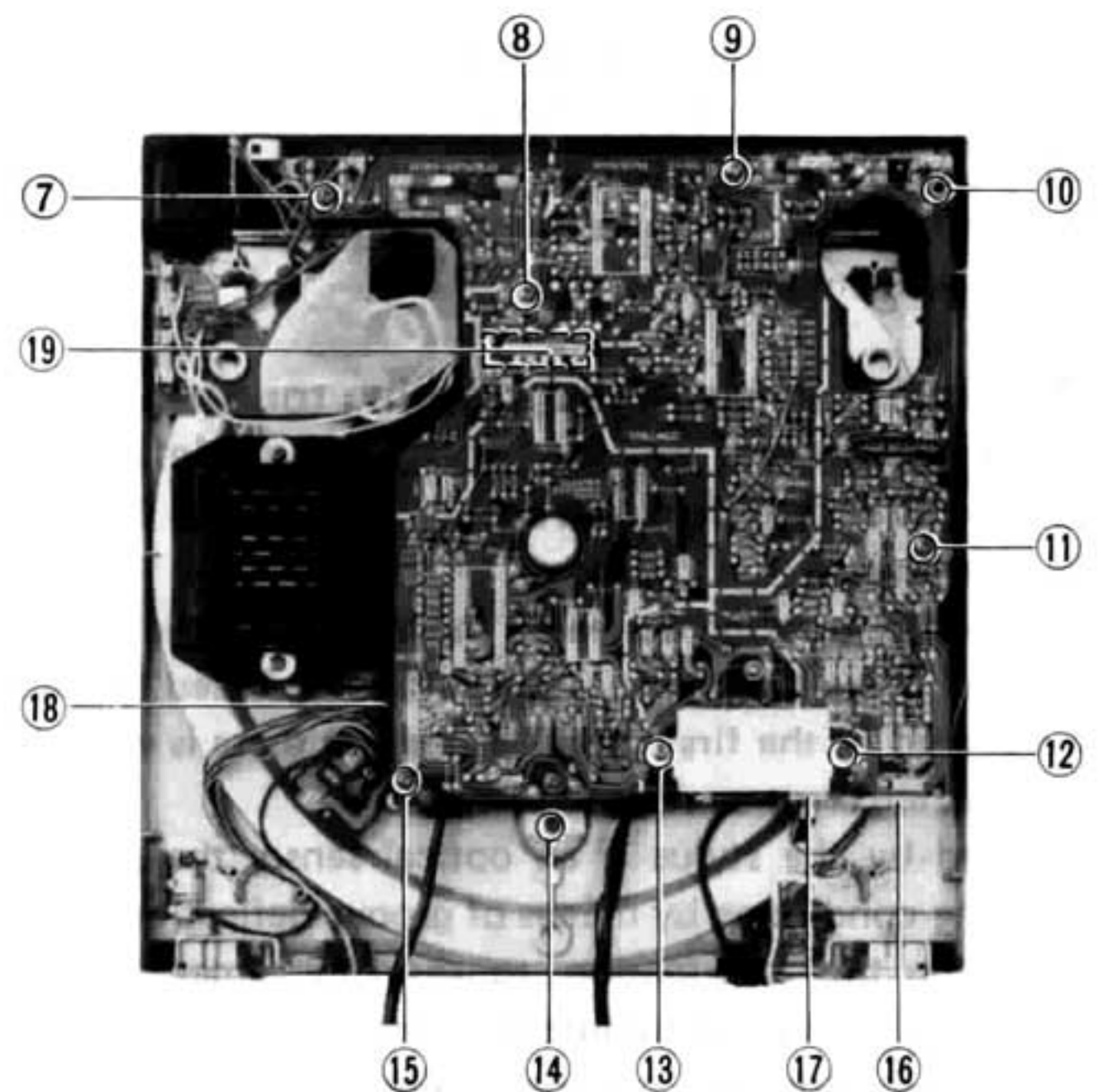

Photo 3

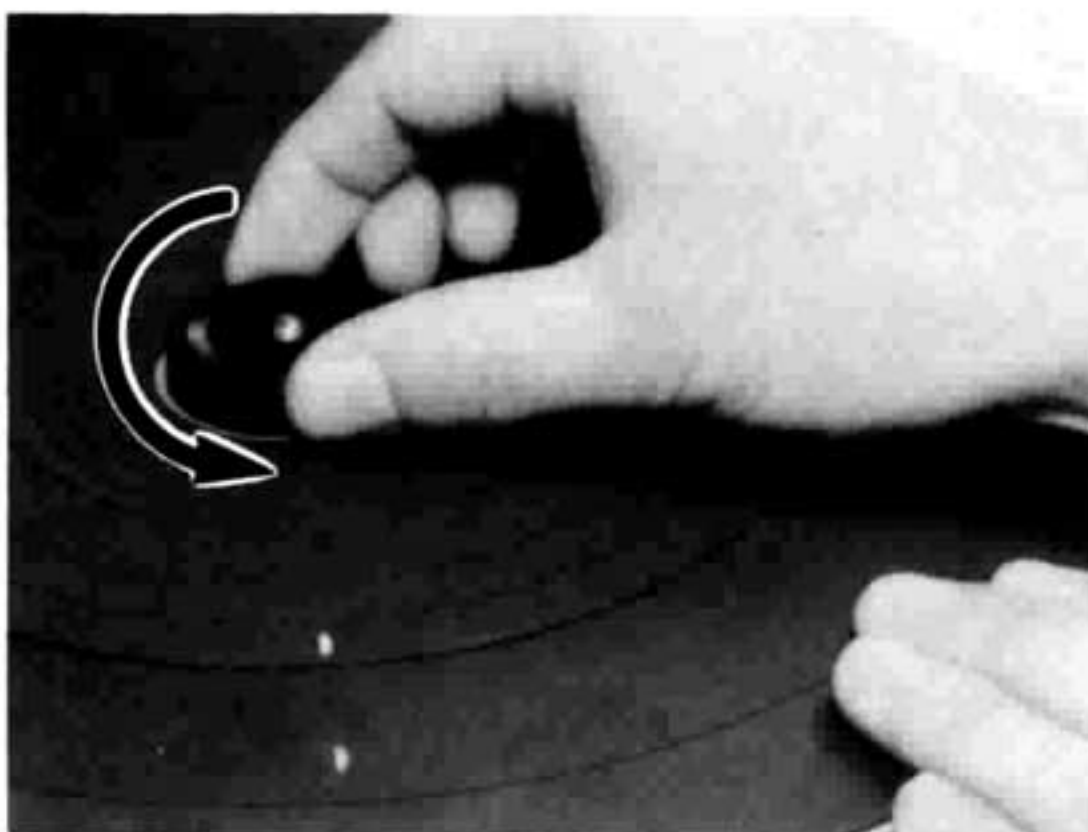

Photo 4

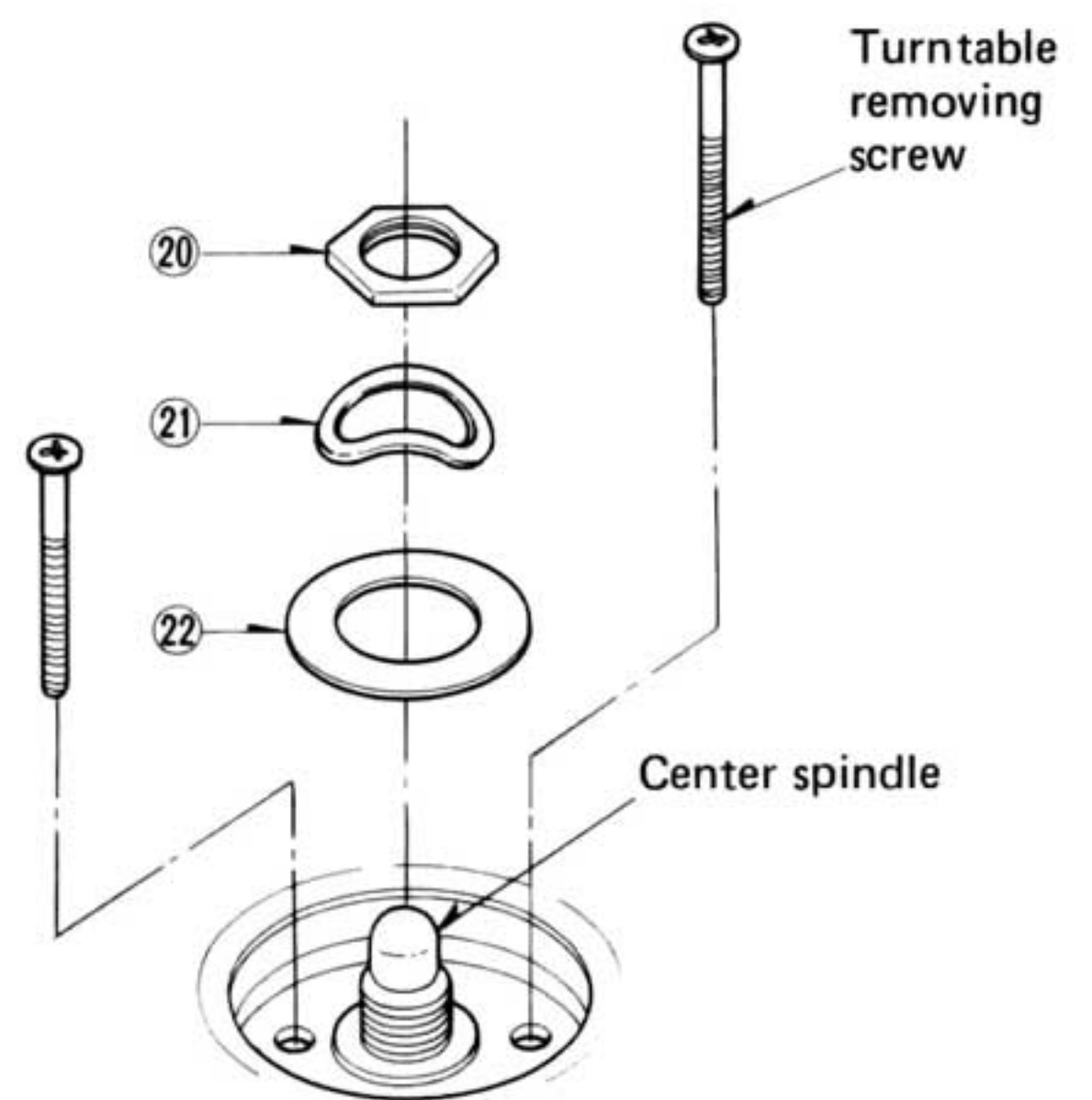

Fig. 1

How to remove the stator frame

1. Remove the turntable. (Refer to "How to remove the turntable".)
2. Remove the main P.C.B. (Refer to "How to remove the bottom board and main P.C.B.".)
3. The stator frame can be removed by removing the set-screws ⑳ ~ ㉔ . (See photo 5.)

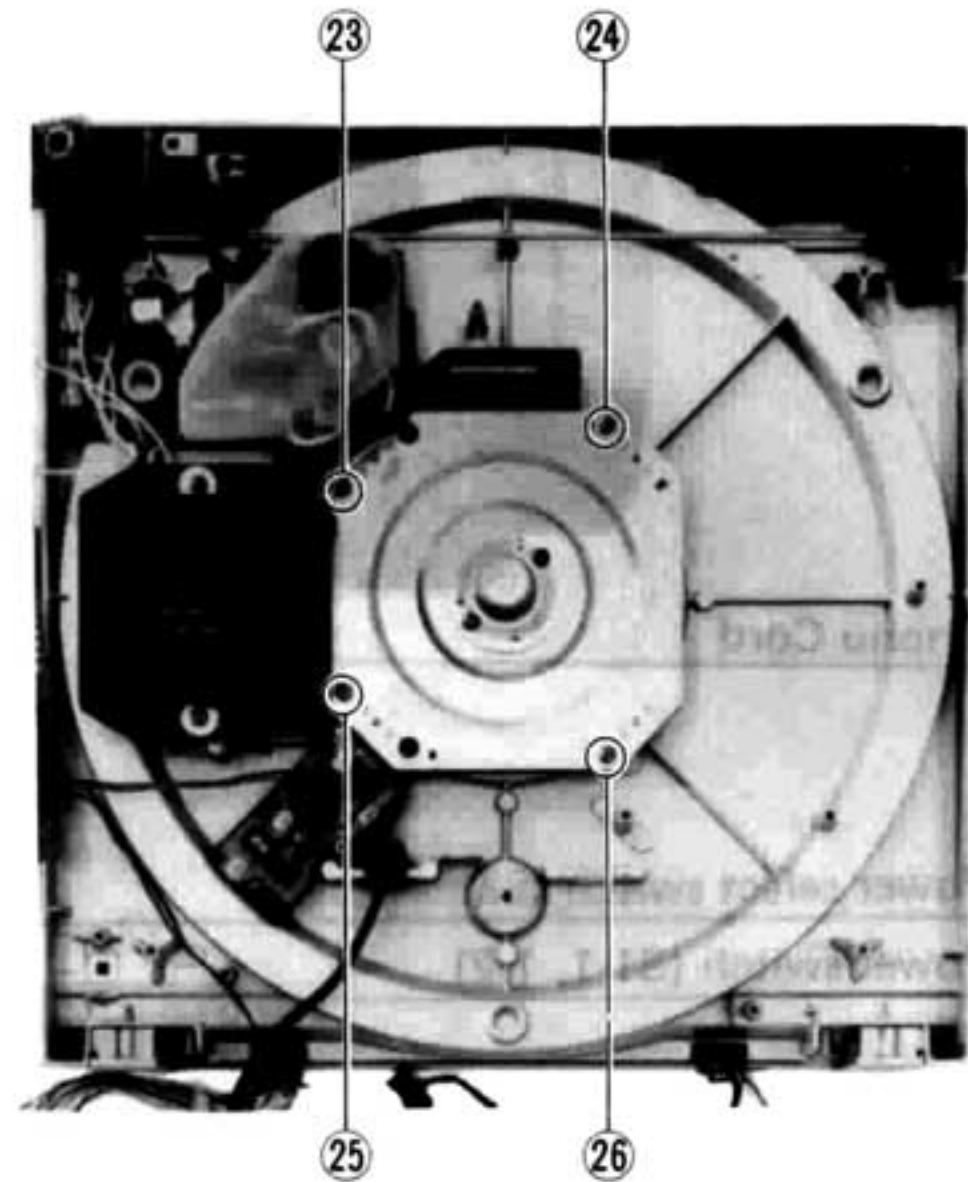
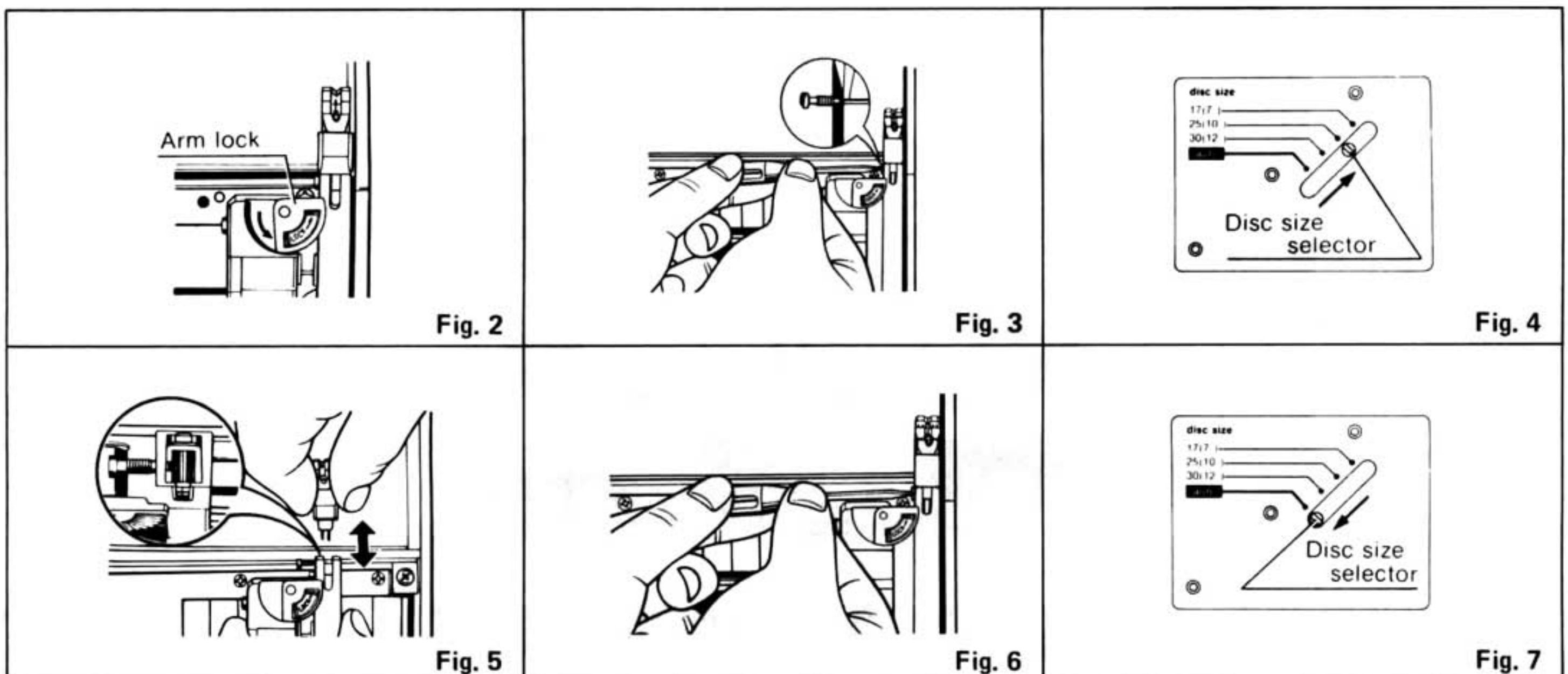

Photo 5

How to remove the cartridge

1. Open the upper cabinet and turn the arm lock in the direction of arrow to lock the tonearm. (See Fig. 2.)
2. Loosen the cartridge setscrew by using the attached screwdriver. (Completely loosen the screw until it is feed as shown in Fig. 3.)
3. Set the disc size selector knob to the 25cm position. (See Fig. 4.)
4. Close the upper cabinet, set the power switch to "on" and push the start button, then the tonearm moves to the guide groove position for 25cm record and stops there.

5. Set the power switch to "off" and open the upper cabinet.
6. Draw out the cartridge. (See Fig. 5.)
7. When inserting the cartridge again, completely insert it aligning the cartridge pin to the connector while taking care not to touch the stylus.
8. Set the power switch to "on" to shift the tonearm back to the start position and then tighten the setscrew. (See Fig. 6.)
9. Set the disc size selector knob back to the **auto** position. (See Fig. 7.)



How to remove the dust cover and disc size sensor P.C.B.

1. Shift the tonearm inside and remove the cartridge.
(Refer to "How to remove the cartridge".)
2. With the tonearm shifted inside, remove the dust cover setscrews ②⑦ ~ ③③. (Refer to photo 6.)
3. The dust cover can be removed by pulling it toward you while lifting it in the direction of the arrow.
(See photo 6.)
*When removing the dust cover, be sure to lift it in the direction of the arrow because the part ③④ is engaged with the dustcover.
4. The disc size sensor P.C.B. can be removed by removing the disc size sensor P.C.B. setscrew ③⑤ and connector ③⑥. (See photo 7.)

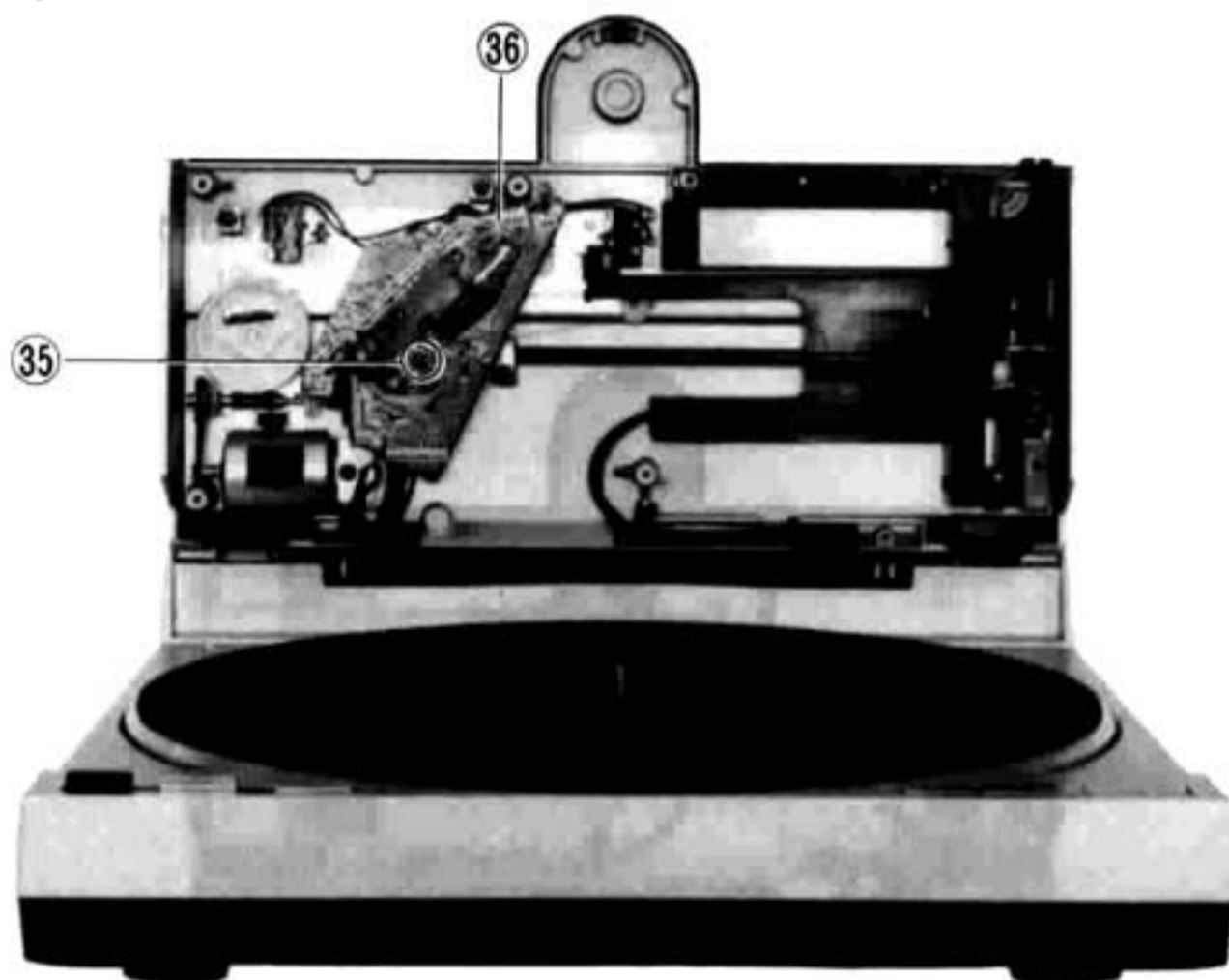
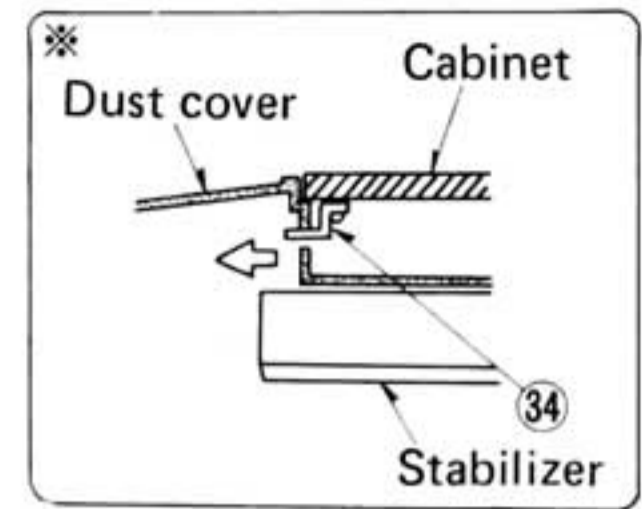

Photo 7

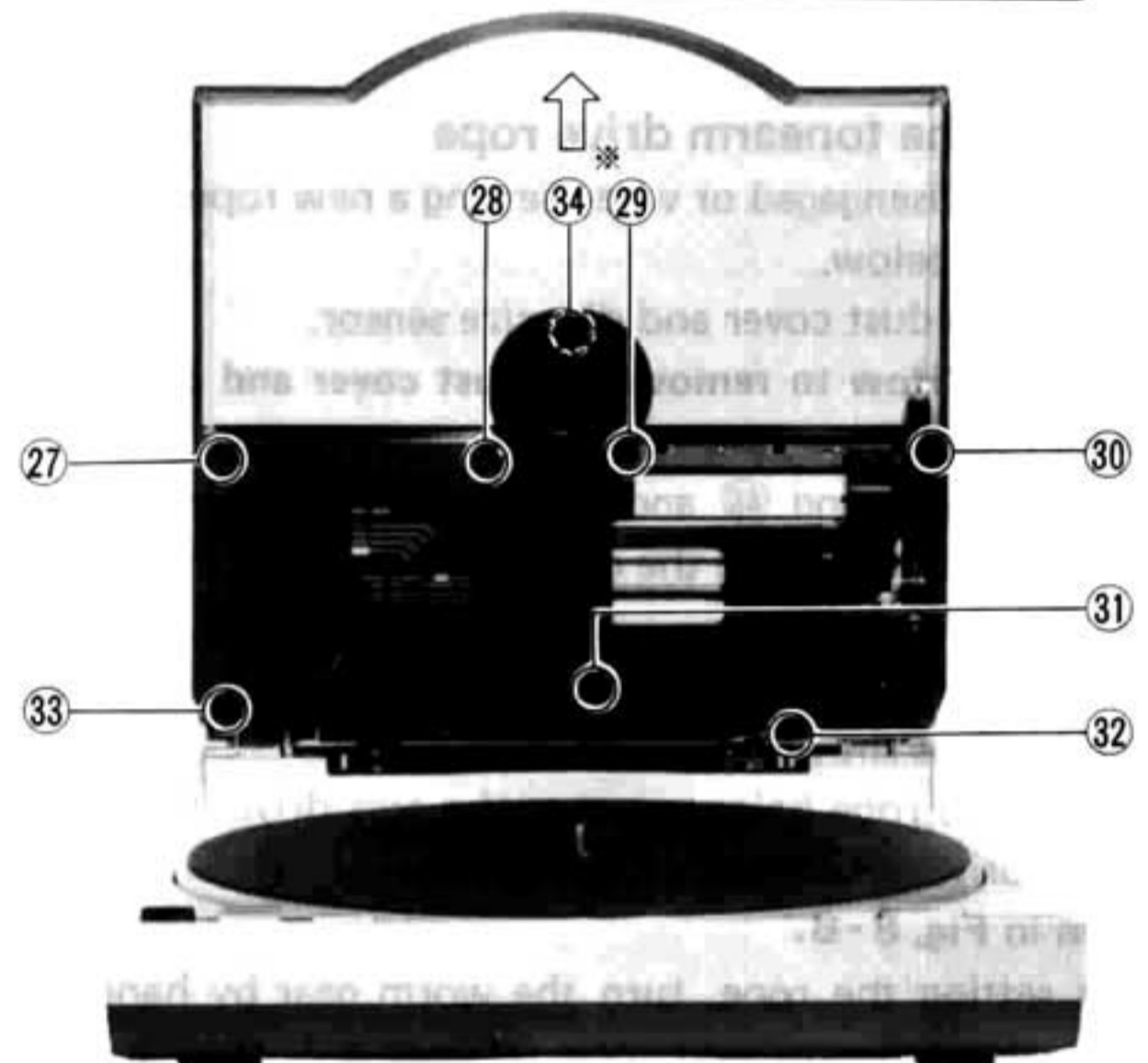

Photo 6

How to remove the tonearm

1. Remove the dust cover. (Refer to "How to remove the dust cover".)
2. Remove the bottom board and rear cover, and connectors ①⑥ ~ ①⑧. (Refer to "How to remove the bottom board and main P.C.B.".)
3. Remove the hinge setscrews ③⑦ ~ ④①. Then the upper cabinet can be removed. (See photo 8.)
4. Remove the clamps ④① and ④② which secure the two connectors of the tonearm, and remove the disc size sensor P.C.B.
5. Remove the tonearm rope retaining part setscrews ④③ and ④④. Then the tonearm unit can be removed.
(See photo 10.)

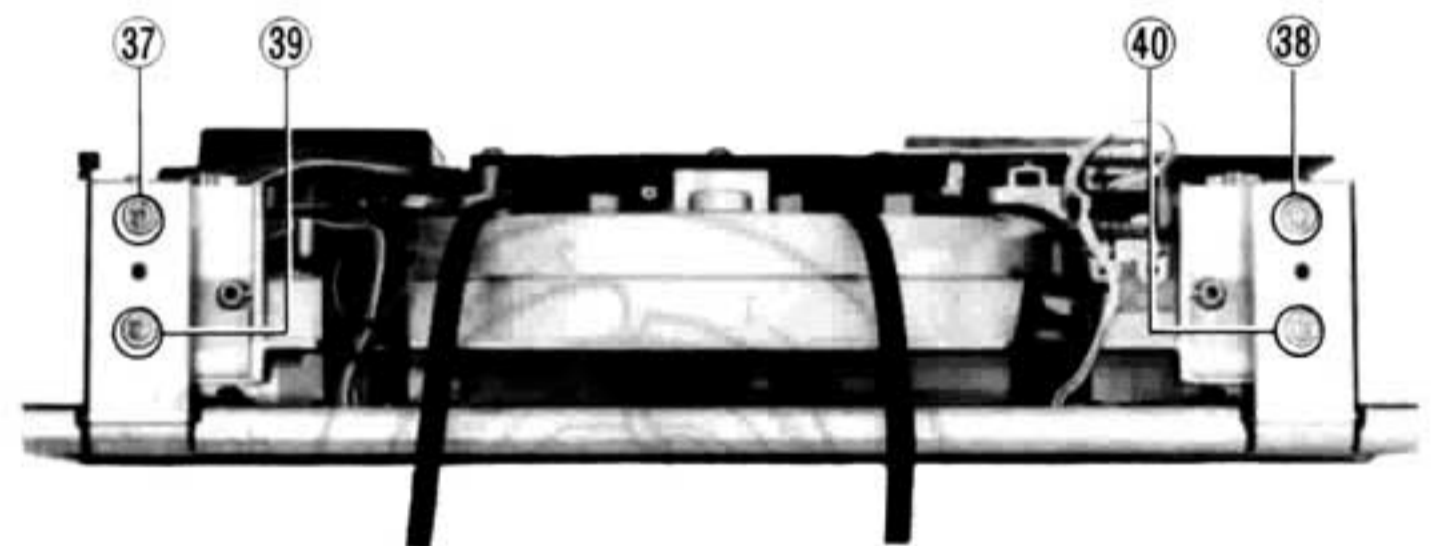

Photo 8

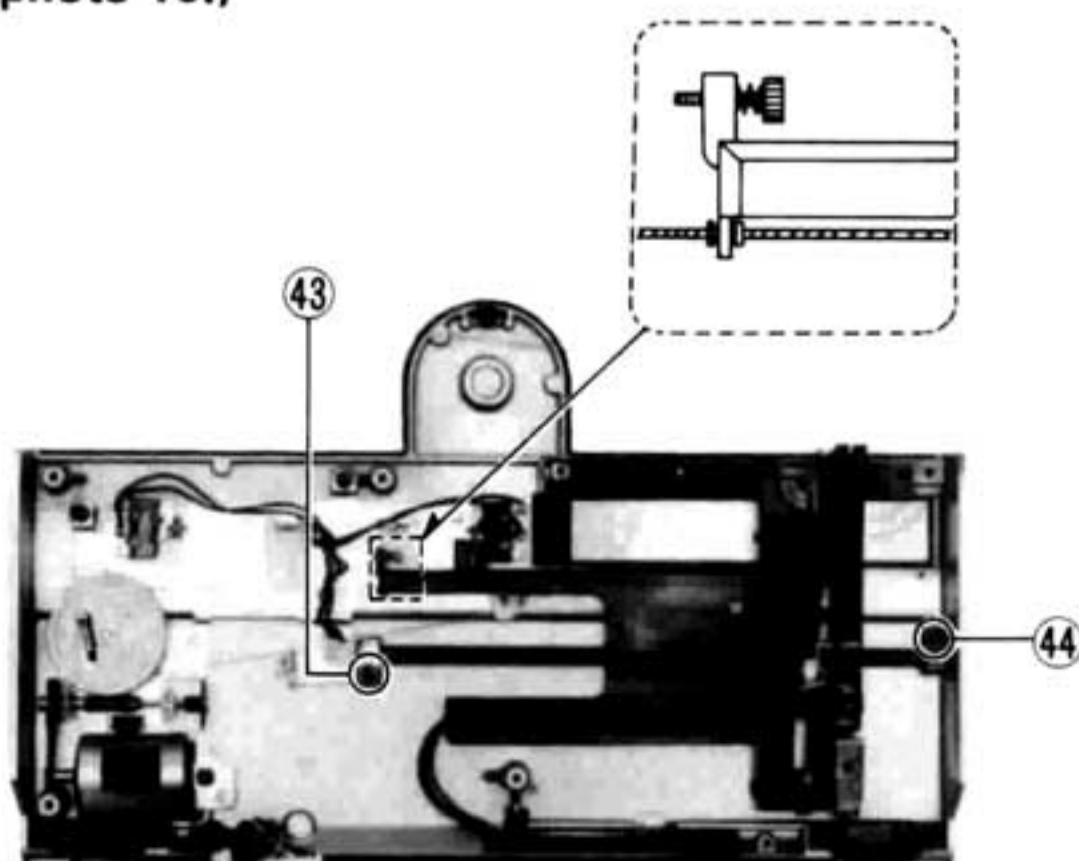

Photo 10

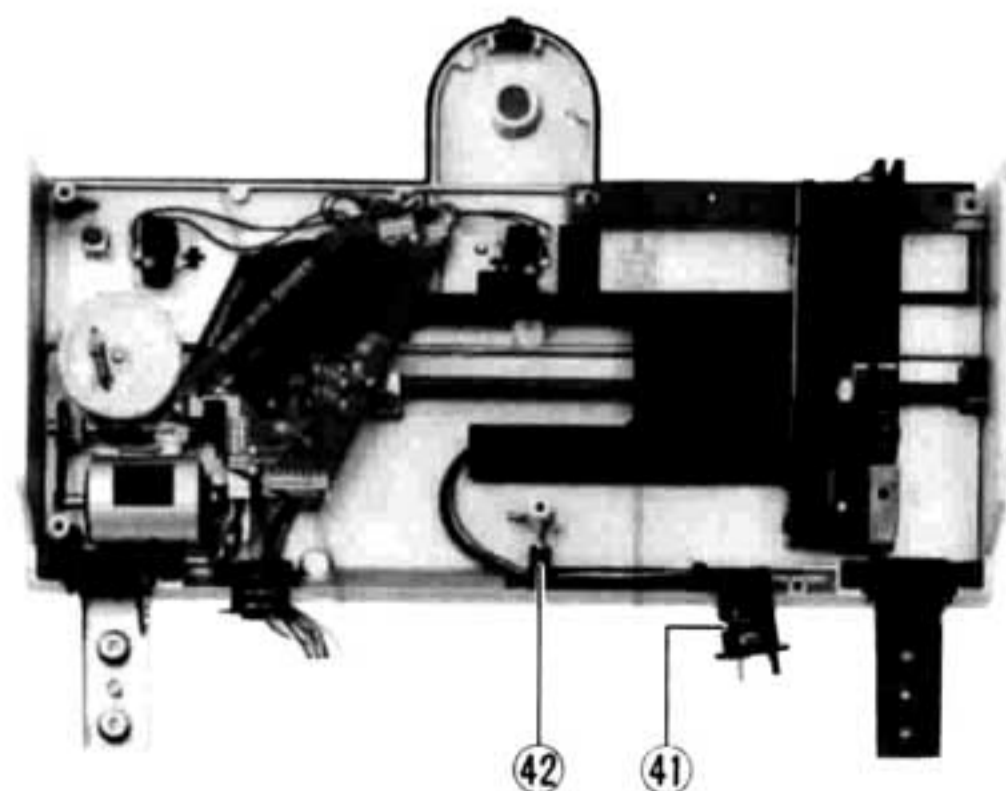

Photo 9

How to remove the surface plate

When adjusting the auto start or return position, remove the surface plate according to the following procedure.

1. Close the upper cabinet.
2. Loosen the surface plate by using a flat head screw driver. (See photo 11.)

Note: The surface plate is secured with double-sided adhesive tape. So, slowly remove the surface plate with care not to scratch the plate.



Photo 11

How to set the tonearm drive rope

If the rope is disengaged or when setting a new rope, follow the procedure below.

1. Remove the dust cover and disc size sensor. (Refer to "How to remove the dust cover and disc size sensor P.C.B.")
2. Remove the E-ring (46) and washer (47) of the arm drive drum, and then remove the drive wheel. (See photo 12.)
3. Turn over the arm drive drum, and set the rope in order of ① ~ ③ as shown in Fig. 8-A.
4. Holding the rope being set over the arm drive drum, set up the drive drum and rope in order of ④ ~ ⑤ as shown in Fig. 8-B.
5. After setting the rope, turn the worm gear by hand to adjust the tonearm and rope retainer and then secure the part.
6. Make sure that the tonearm moves when the worm gear is turned by hand.
7. Attach the E-ring (46) and washer (47). (See photo 12.)

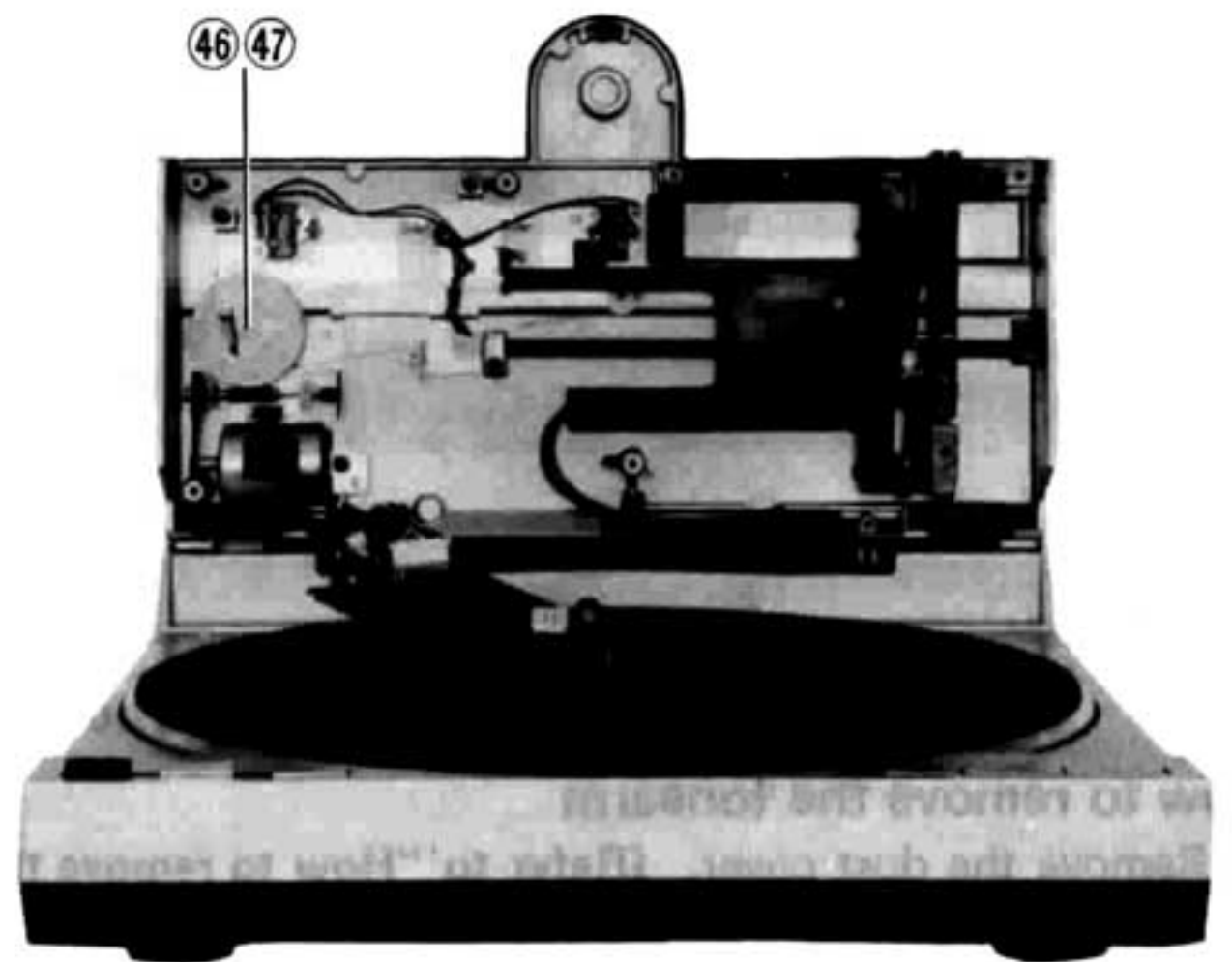

Photo 12

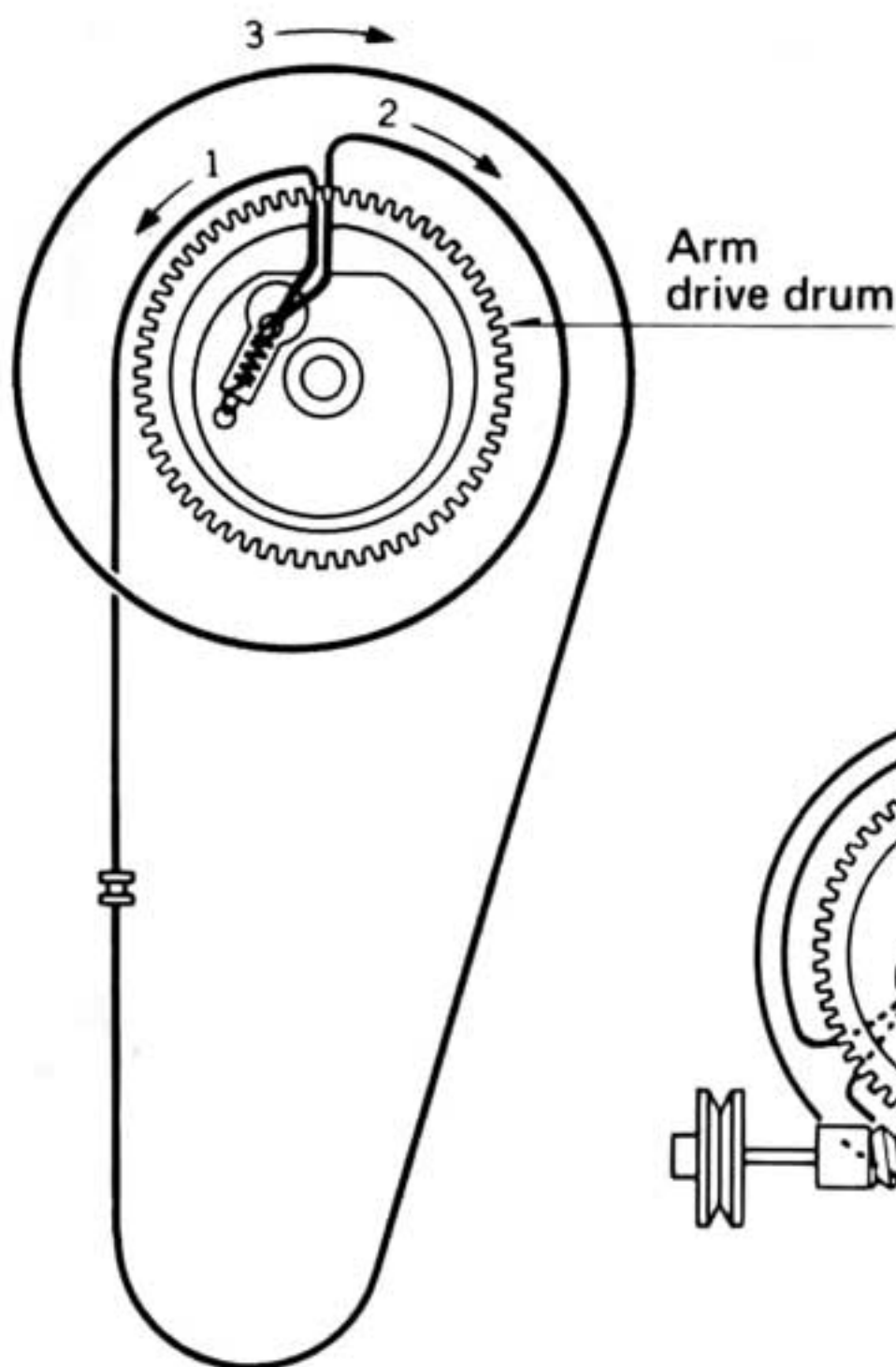

Fig. 8-A

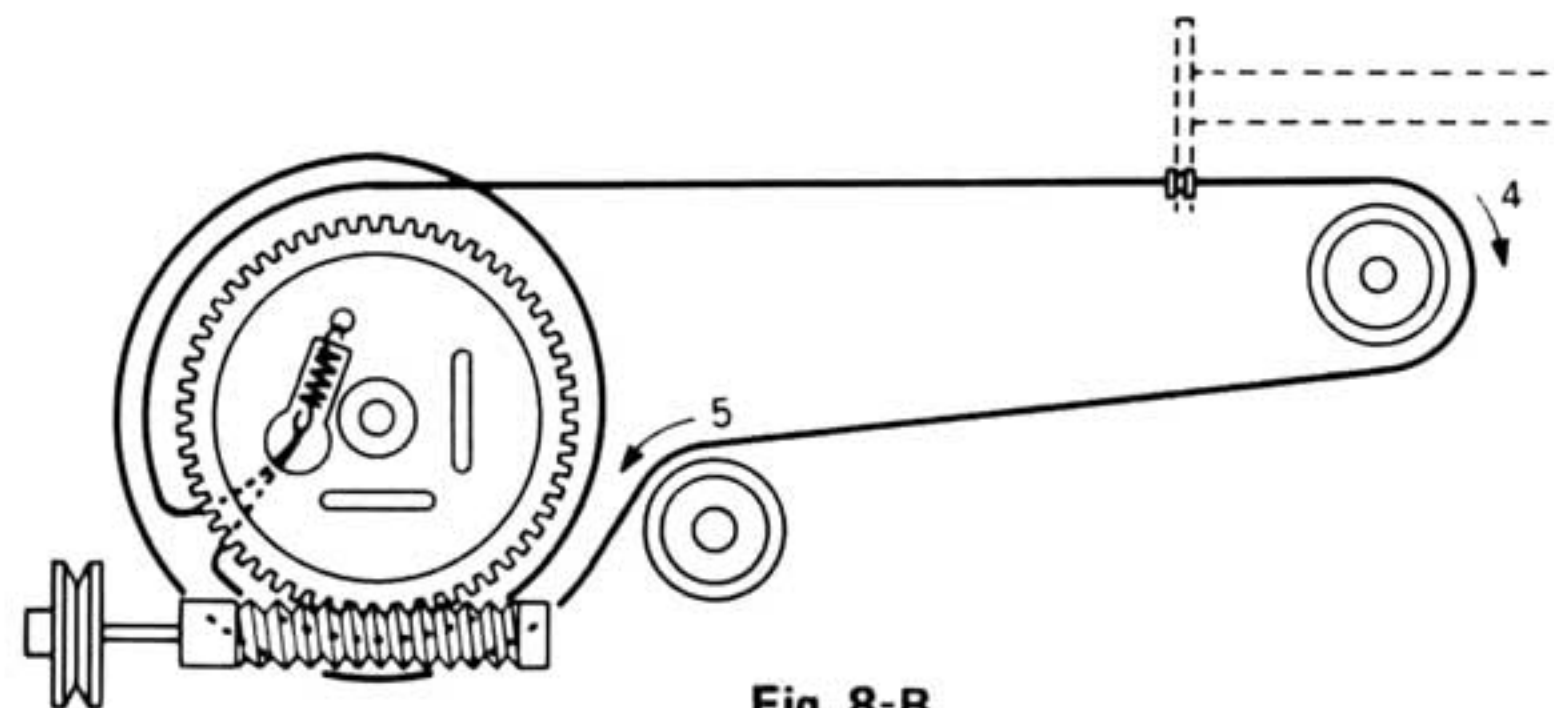

Fig. 8-B

DESCRIPTION OF CONNECTOR

There are two types of connectors used in this unit: one is directly soldered to the printed circuit board, and the other is of insertion type.

Note: That soldered connectors cannot be pulled out.

The types of connectors and their positions are shown

Fig. 9.

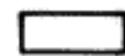
 ----- Soldered
 ----- Inserted

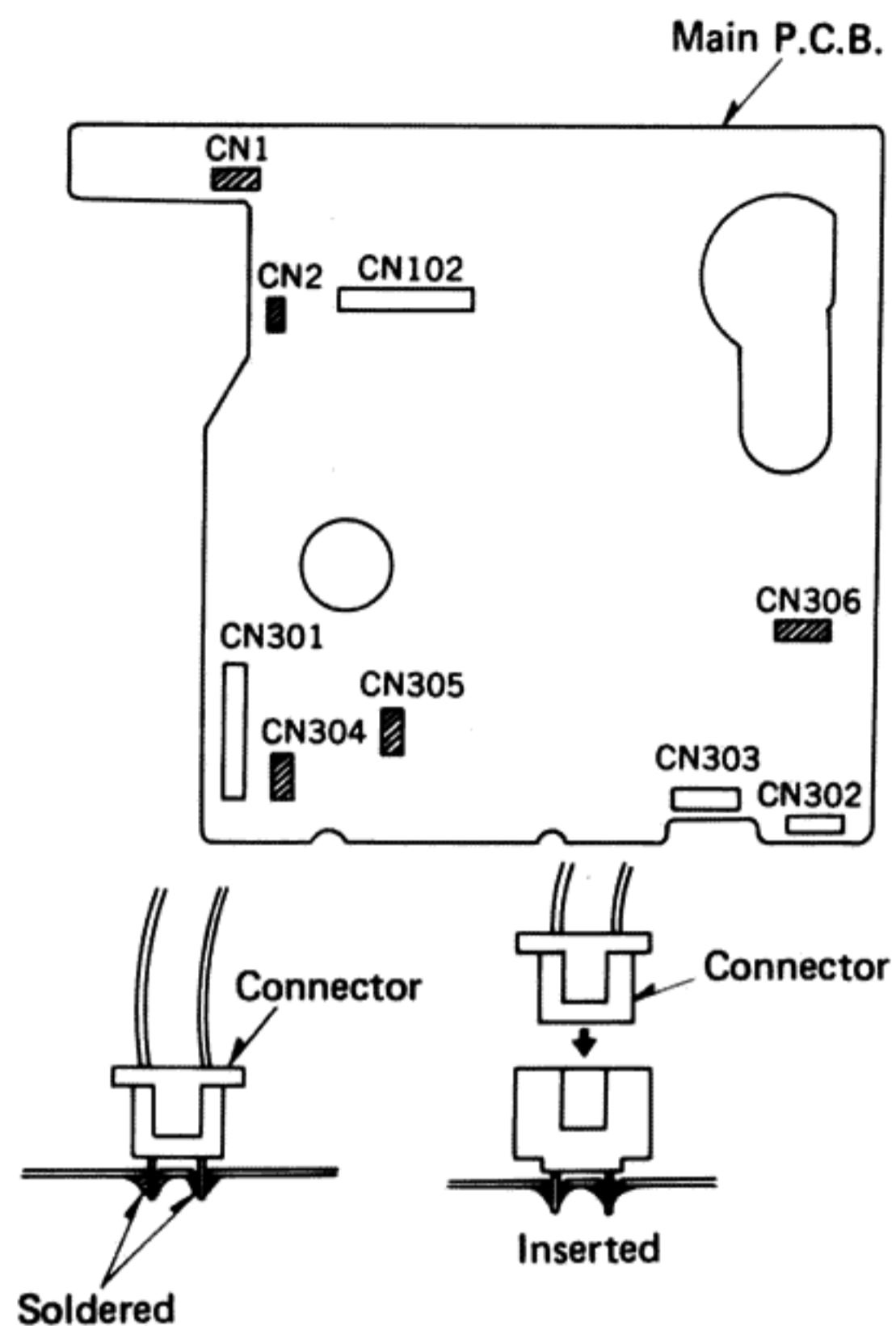

Fig. 9

REPLACEMENT OF HALL ELEMENT

When replacing the Hall element of the stator fram, be sure to place it with the marking side up as shown **Fig. 10.**

* The leg position is not specified provided that the marking side is up.

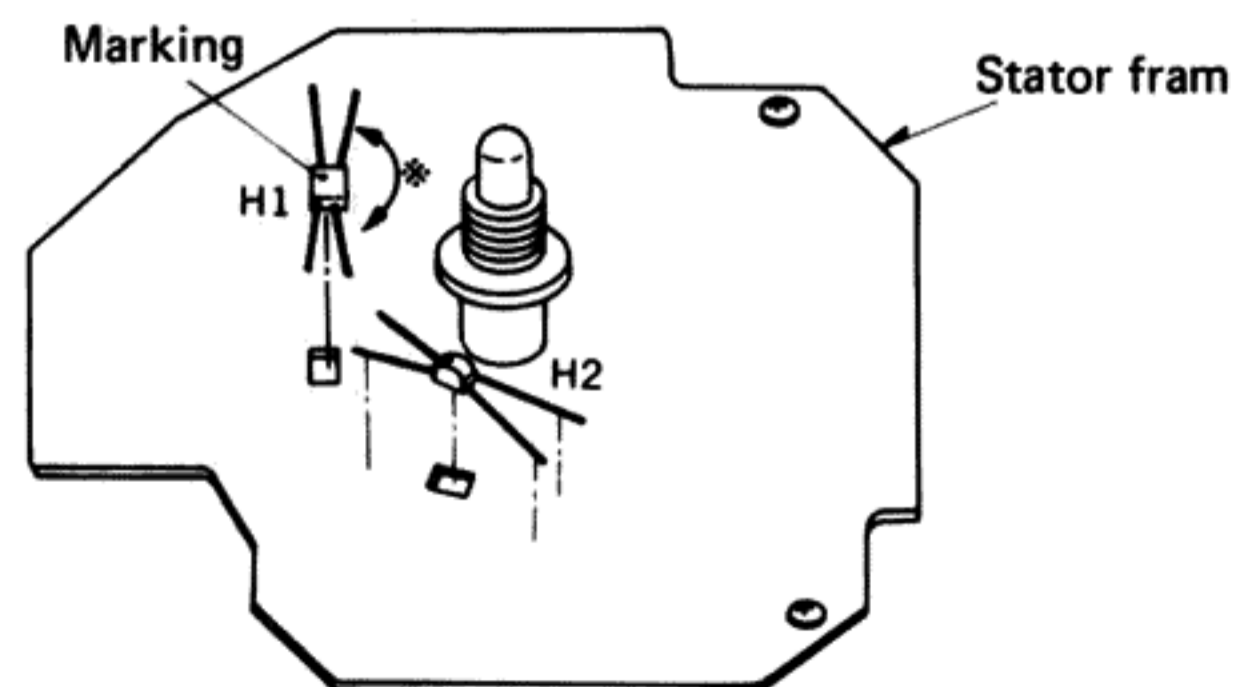

Fig. 10

Adjustment of auto start and auto return position

Auto start position

(Be sure to use a 30cm disc for the adjustment.)

1. Remove the surface plate. (Refer to "How to remove the surface plate".)
2. Make sure that the tonearm is at the start position (tonearm rest position)
3. Make the adjustment by turning the auto start position adjust screw. (See photo 13.)
 - If the tonearm lowers after passing over the start position. Turn the adjust screw clockwise
 - If the tonearm lowers before reaching the start position. Turn the adjust screw counterclockwise.
4. After the adjustment, remember to lock the adjust screw with bond.

Auto return position

(Be sure to use a 17cm disc for the adjustment.)

1. Remove the surface plate. (Refer to "How to remove the surface plate".)
2. Make the adjustment by inserting a flat head screwdriver into the adjusting hole. (See photo 13.)
 - If the tonearm returns before the end of the play Turn the screwdriver clockwise.
 - If the tonearm does not return even after the end of the play. Turn the screwdriver counterclockwise.

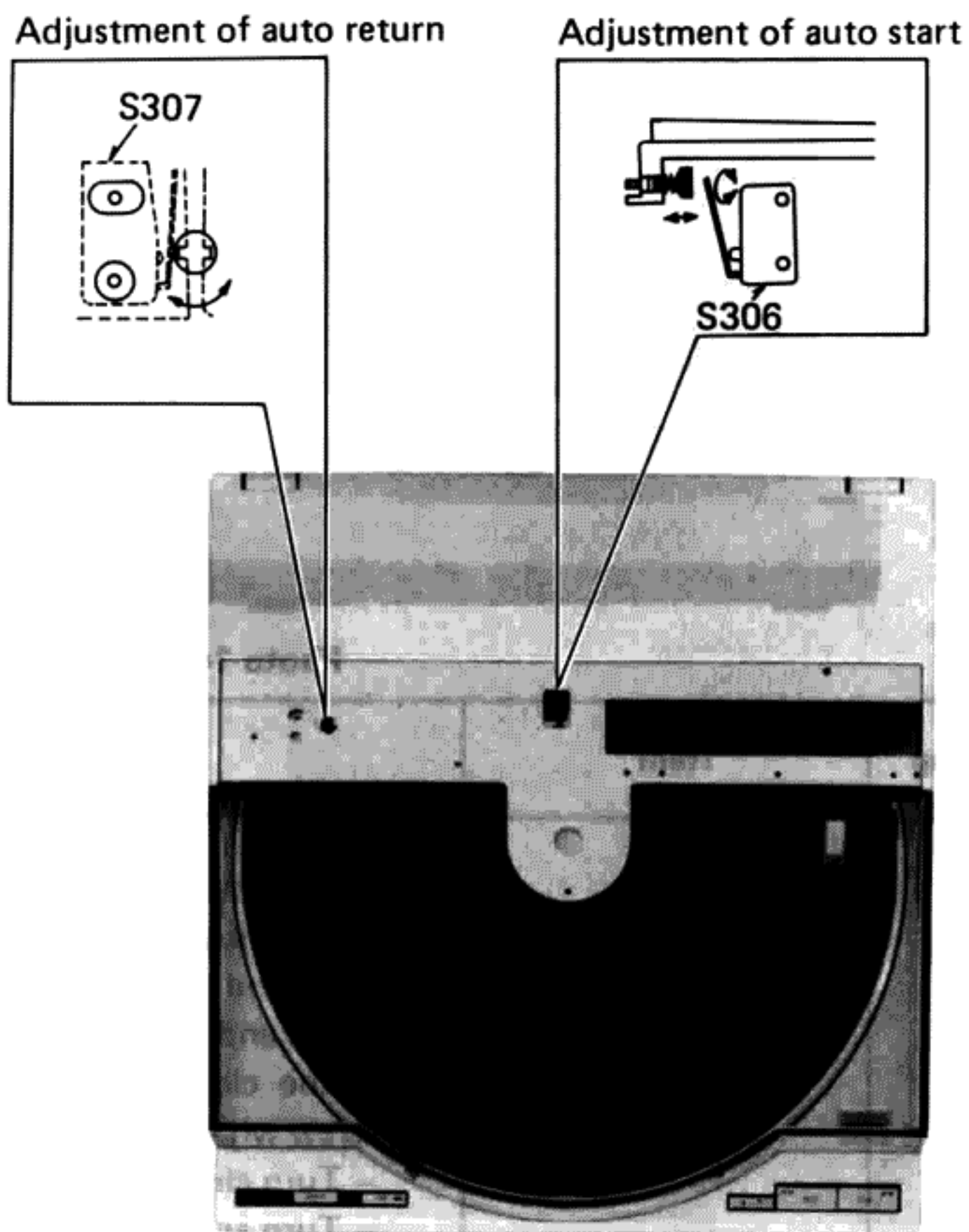

Photo 13

Adjustment for the stylus pressure (See Fig. 11.)

Stylus pressure is normally set to 1.25 grams but may be raised or lowered by ± 0.25 grams. It may be necessary to increase stylus pressure when playing records cut at high levels, or when room temperature is low, or when the unit easily picks up external vibrations. This will help prevent distortion and groove-skipping. To adjust stylus pressure, turn either way, as shown in the diagram. The screw is coupled to the graduated ring.

Note: Do not turn the stylus pressure adjustment screw further than the set limits (1.5 g ~ 1.0 g)

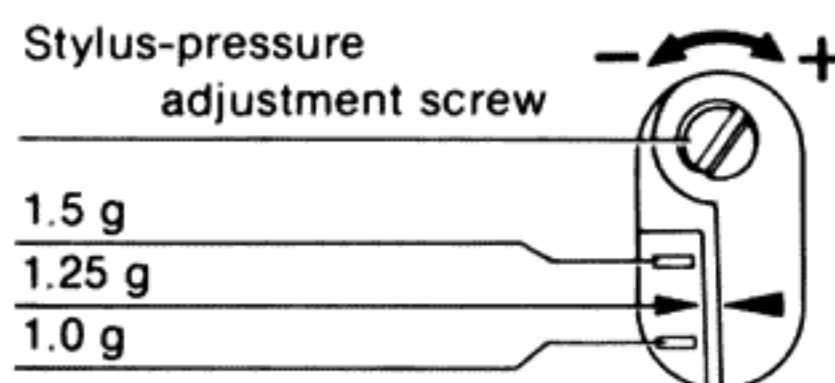

Fig. 11

Offset adjustment of tonearm and servo gain

After repair of the tonearm and arm drive circuit, make the adjustment according to the following procedure.

Tools and equipment used

1. DC Voltmeter or tester
2. 1mm pitch record
3. Flat head screwdriver (small)
4. Philips head screwdriver (small)
5. Hexagon wrench (1.5M)

Condition of the set

1. Remove the dust cover and surface plate. (Refer to "Disassembly instructions".)
2. Set the disc size select knob to the 30cm position.
3. Turn the cover switch (S305) "on" by pressing it with tape. (See photo 14.)
4. Remove the label on the rear cover. (See photo 15.)
5. Completely open the upper cabinet and make sure that the tonearm operates when the start button is pressed.

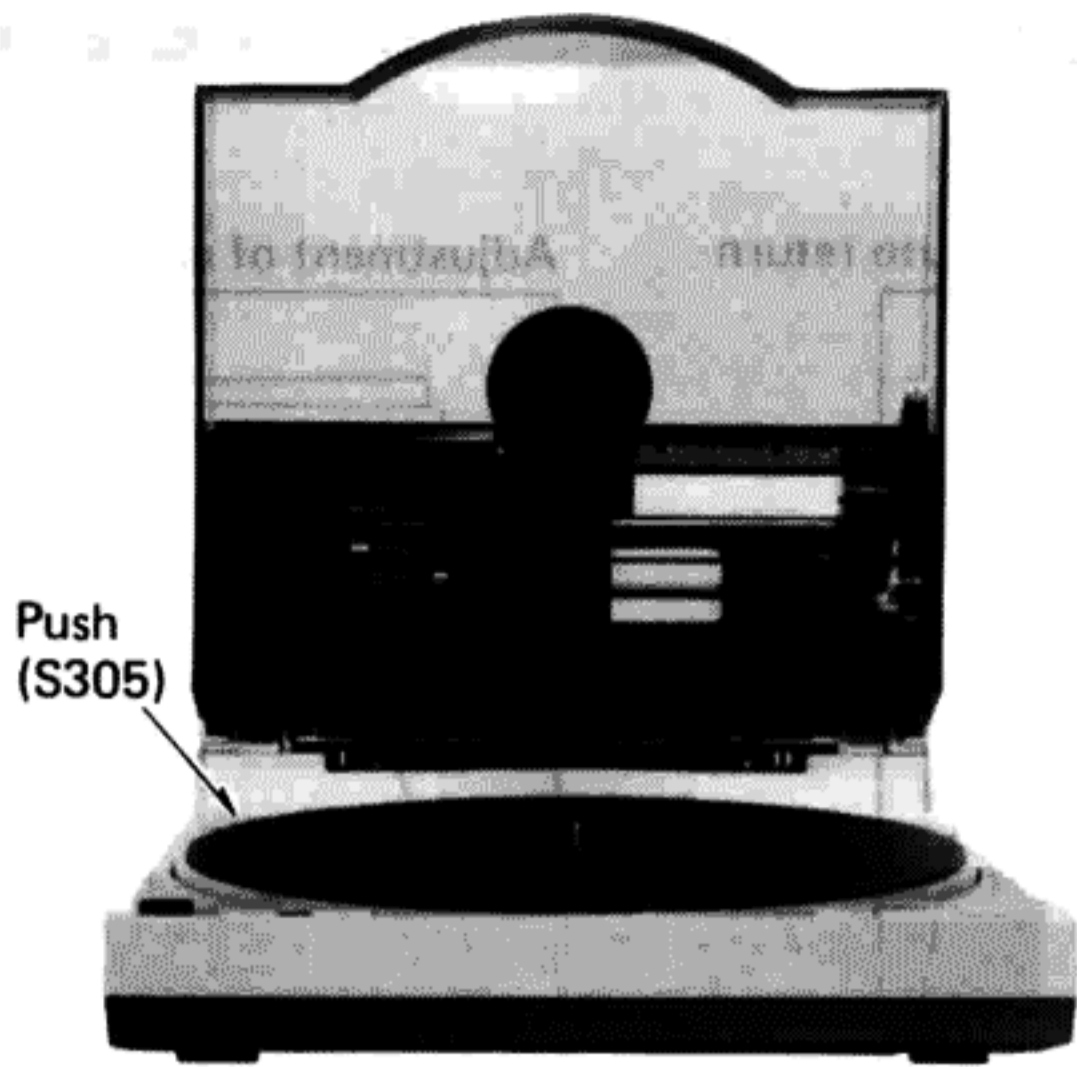

Photo 14

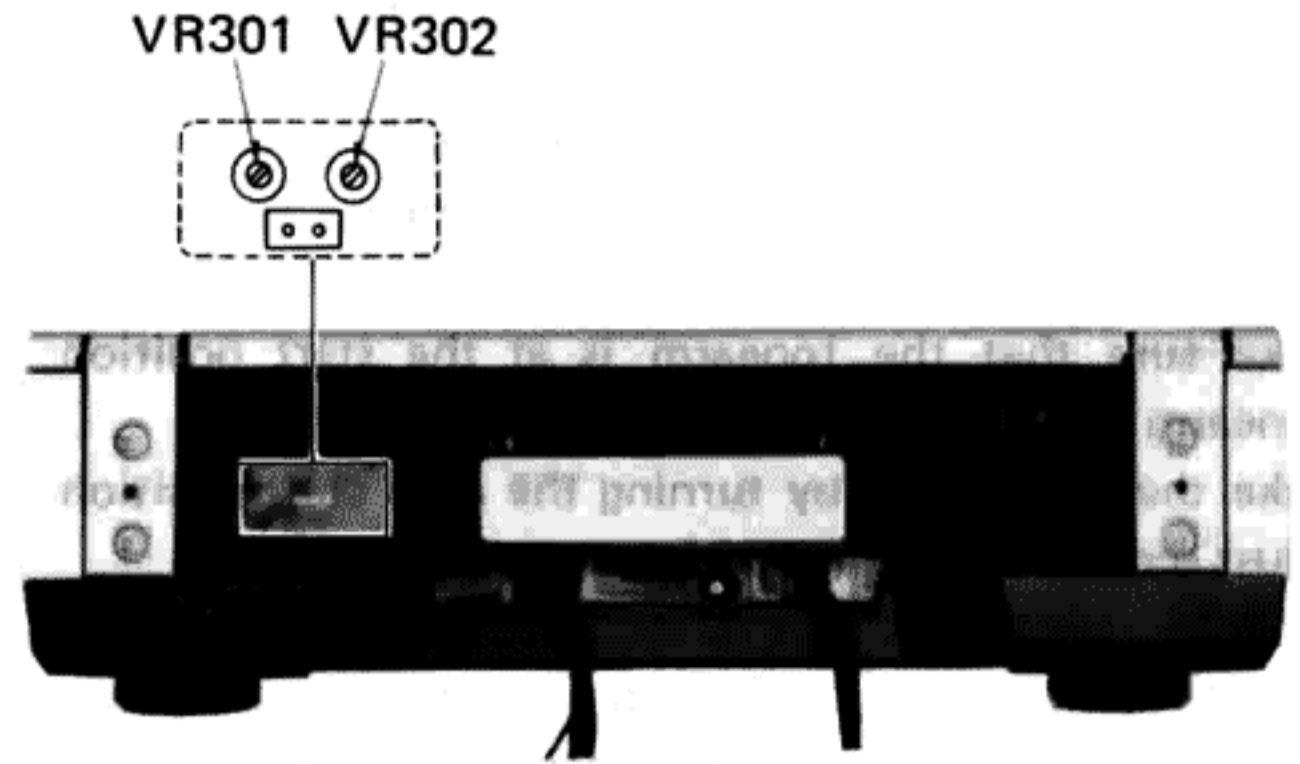
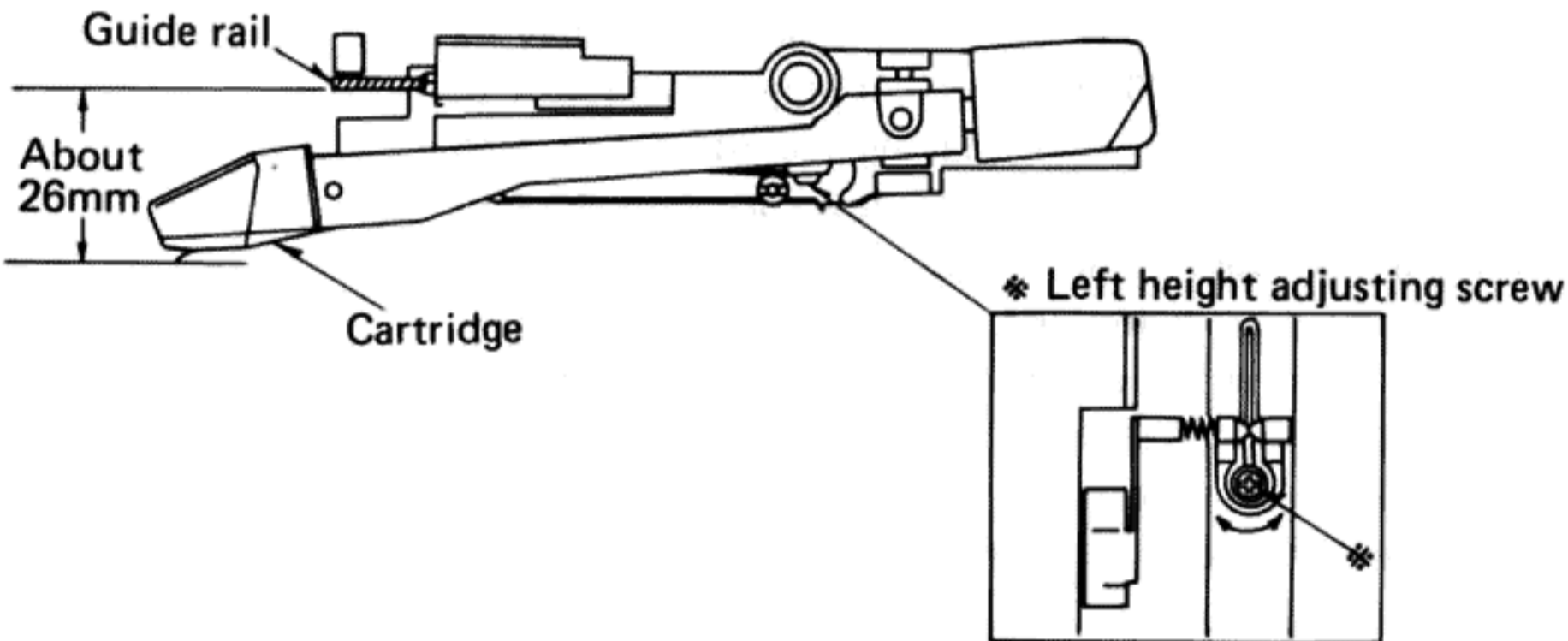
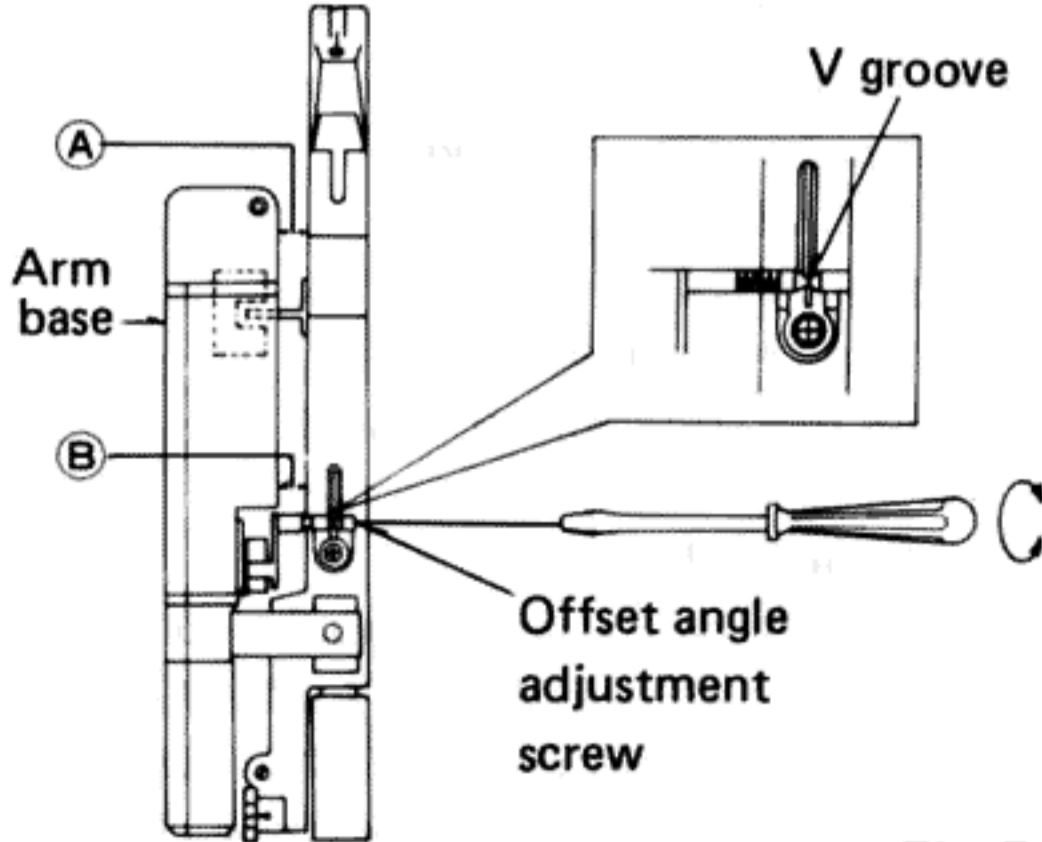
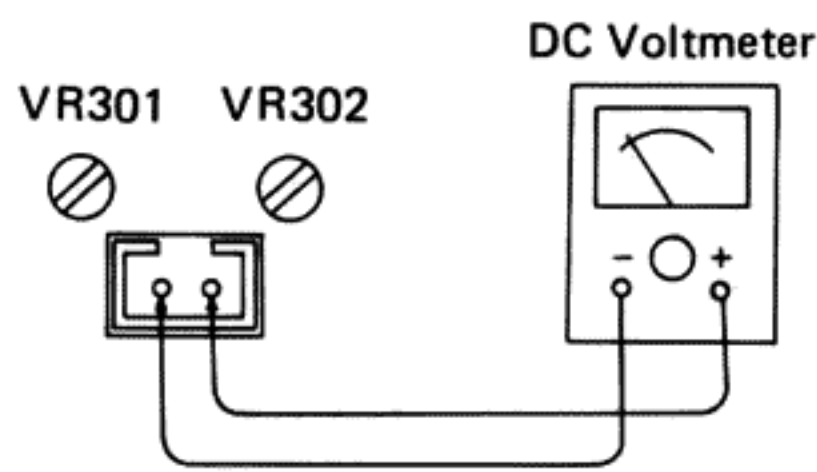
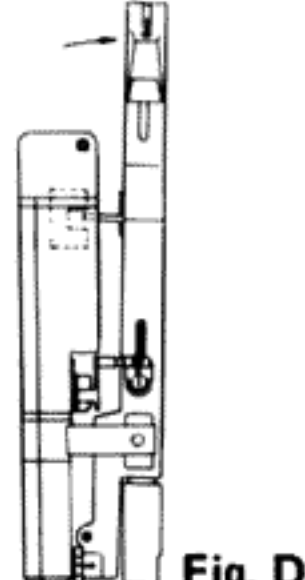
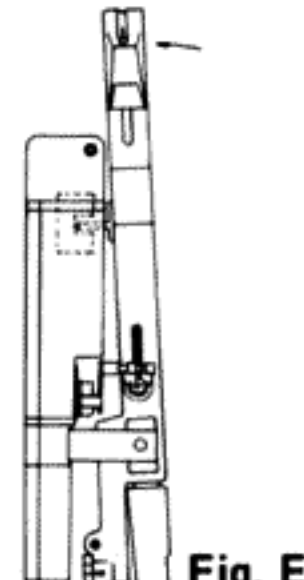
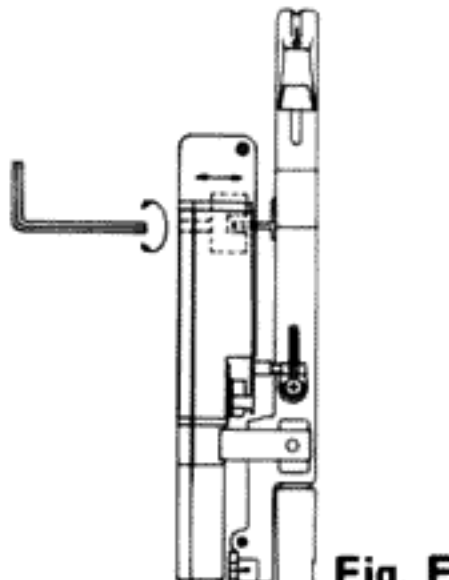
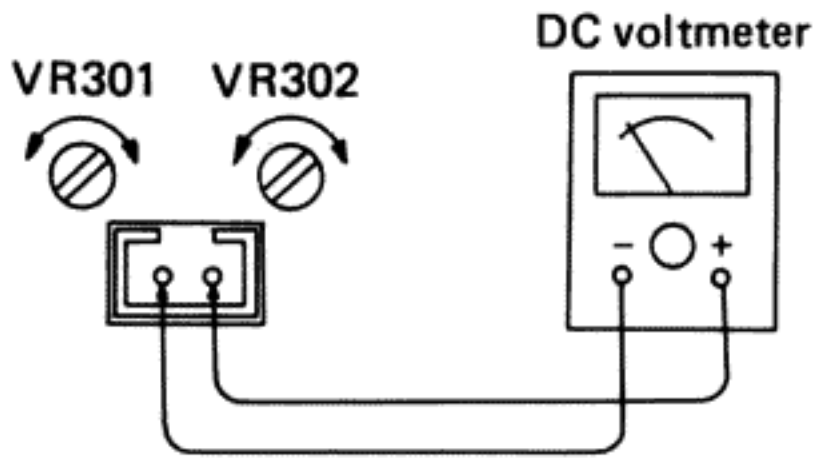
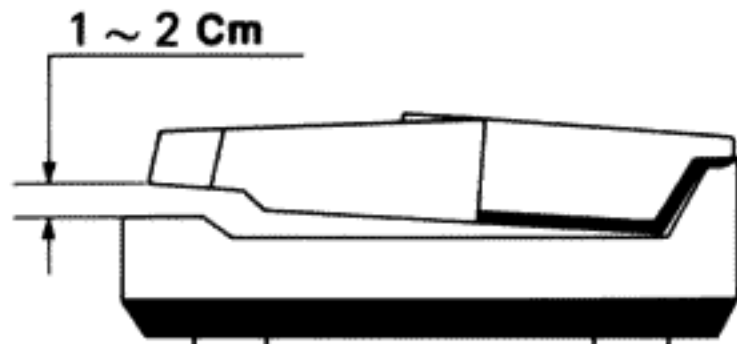

Photo 15

Step	Item	Adjustment method
1	<p>Adjustment of arm lift height (See Fig. A.)</p>	<ol style="list-style-type: none"> ① Turn the power switch "on" and move the tonearm towards the center of disc by pressing the start button. ② Press the cueing button to check that the clearance between the cartridge stylus and the guide rail is about 26mm. ③ If the clearance is incorrect, adjust the lift height by turning the adjusting screw with a flat head screwdriver. <ul style="list-style-type: none"> – Turn clockwise when excessive (> 26mm). – Turn anticlockwise when insufficient (< 26mm). <p>Note: The lift height adjusting screws of the replacement tonearm is completely tightened up. So, loosen the adjusting screw before making the above adjustment.</p>  <p style="text-align: right;">Fig. A</p>
2	<p>Offset angle adjustment of tonearm (See Fig. B.)</p>	<ol style="list-style-type: none"> ① Turn the power switch "on" and move the tonearm towards the center of disc by pressing the start button. ② Make sure that the arm center is aligned with the V groove of the lift lever. ③ Make sure that the arm base is in parallel with the arm. (Check the clearance between (A) and (B) in Fig. B.) ④ If the arm base is not in parallel with the arm, adjust it by turning the offset angle adjusting screw.  <p style="text-align: right;">Fig. B</p>

Step	Item	Adjustment method
3	Adjustment of arm lift height	<p>① Turn the power switch "on" and move the tonearm towards the center of disc by pressing the start button.</p> <p>② Press the cueing button and make sure that the arm is lowered.</p> <p>③ Connect the DC Voltmeter to the connector pin in the adjusting hole of the rear cover. (See Fig. C.)</p> <p>④ Read the voltage values with the tonearm fully shifted to the right and left respectively. (See Fig. D, E)</p> <p>⑤ Calculate the center voltage from the difference between the two voltage values. For example, when the voltage is 15V in fig. D and 0.02V in fig. E then $\frac{(15V - 0.02V)}{2} + 0.02V = 7.49V$ (middle point voltage)</p> <p>⑥ Set the tonearm to the center position, and turn the adjusting screw of the arm base by a hexagon wrench until the center voltage is achieved. (See Fig. E.)</p>    
4	Servo gain and offset adjustment	<p>Adjustment, removing the dust cover: (See Fig. G.)</p> <p>① Turn the power switch "on" and move the tonearm towards the center of disc by pressing the start button.</p> <p>② Press the cueing button and make sure that the tonearm is lowered.</p> <p>③ Connect the DC Voltmeter to the connector pin in the adjusting hole of the rear cover.</p> <p>④ Make sure that VR301 has been completely turned clockwise.</p> <p>⑤ Turn VR302 until the DC Voltmeter indicates 0.72V. (Servo gain adjustment)</p> <p>⑥ Play the 1mm-pitch record on the turntable.</p> <p>⑦ Turn VR301 until the DC Voltmeter indicates 0.6V. (Offset adjustment)</p> <p>Adjustment without removing the dust cover: (See Fig. H.)</p> <p>① Put a record on the turntable.</p> <p>② Open the dustcover 1 or 2cm, turn the power switch "on" and lower the tonearm. (In this case, do not allow the stylus to touch the disc.)</p> <p>③ Connect the DC Voltmeter to the connector pin in the adjusting hole of the rear cover.</p> <p>④ Make sure that VR301 has been completely turned clockwise.</p> <p>⑤ Turn VR302 until the DC Voltmeter indicates 0.72V. (Servo gain adjustment)</p> <p>⑥ Put a 1mm-pitch record on the turntable, close the dust cover, and play the record.</p> <p>⑦ Turn VR301 until the DC Voltmeter indicates 0.6V. (Offset adjustment)</p>  

Justierung der Auto-start-und Auto-Rückkehr-Position

Auto-Start-Position

(Für die Justierung ist eine 30cm-Schallplatte zu verwenden.)

1. Die Deckplatte abnehmen. (Siehe "Entfernen der Deckplatte".)
2. Überprüfen, daß der Tonarm in der Start-Position ist (Tonarm-Ruheposition.)
3. Die Justierung durch Drehen der Auto-Start-Position-Justierschraube vornehmen. (Siehe Foto 13.)

Auto-Rückkehr-Position

(Für die Justierung ist eine 17cm-Schallplatte zu verwenden.)

1. Die Deckplatte abnehmen. (Siehe "Entfernen der Deckplatte".)
2. Zum Durchführen der Justierung, einen Flachkopf-Schraubenzieher in das Justierloch einführen. (Siehe Foto 13.)

- Wenn der Tonarm nach Überschreiten der Start-Position (zu spät) abgesenkt wird, die Justierschraube im Uhrzeigersinn drehen.
 - Wenn der Tonarm vor dem Erreichen der Start-Position (zu früh) abgesenkt wird, die Justierschraube entgegen dem Uhrzeigersinn drehen.
4. Nach erfolgter Justierung muß die Justierschraube mit Lack gesichert werden.

- Wenn der Tonarm vor dem Ende des Abspielens zurückkehrt, den Schraubenzieher im Uhrzeigersinn drehen.
- Wenn der Tonarm nach dem Ende des Abspielens nicht zurückkehrt, den Schraubenzieher entgegen dem Uhrzeigersinn drehen.

Justieren Sie die Auflagekraft in dem folgenden Fällen (Siehe Abb. 11.)

Die normale Auflagekraft beträgt 1.25g, doch kann sie um $\pm 0.25g$ gesenkt oder erhöht werden.

Es könnte notwendig sein, die Auflagekraft zu erhöhen, wenn Platten abgespielt werden, die bei hohem Pegel geschnitten wurden, wenn die Raumtemperatur tief ist, oder wenn der Plattenspieler externer Vibration ausgesetzt ist. Dies hilft dabei, Verzerrung und Überspringen der Rillen zu vermeiden.

Zum Justieren der Auflagekraft kann die Schraube nach links oder rechts gedreht werden, wie in der Skizze gezeigt. Die Schraube ist mit dem gradierten Ring gekoppelt.

Anmerkung:

Drehen Sie die Auflagekraft-Justierschraube nie weiter, als bis zu den Begrenzungen (1.5 g ~ 1.0 g)

Reibungswinkel-Justierung des Tonearms und der Servo-Verstärkung

Nach der Reparatur des Tonarms und der Tonarm-Antriebsschaltung, sind die folgenden Justierungen durchzuführen.

Benötigte Werkzeuge und Instrumente

1. Gleichstrom voltmeter oder Prüfaerät.
2. Platte mit 1mm-Rillenabstand
3. Flachkopf-Schraubenzieher (klein)
4. Kreuzkopf-Schraubenzieher (Philips) (klein)
5. Sechskant-Schlüssel (1.5M)

Zustand des Gerätes

1. Die Staubabdeckung und die Plattentellerauflage entfernen. (Siehe "Service-Methode".)
2. Den Plattengröße-Wahlschalter in die 30cm-Position stellen.
3. Den Deckelschalter (S305) durch Drücken mit Band einschalten. (Siehe Foto 14.)
4. Das Etikett an der Rückseite entfernen. (Siehe Foto 15.)
5. Das obere Gehäuse vollständig öffnen und überprüfen, daß der Tonarm funktioniert, wenn die Start-Taste gedrückt wird.

Schritt	Einstellgegenstand	Justiermethode	
1	Justierung der Tonarm-Lifthöhe (Siehe Abb. A)	<ol style="list-style-type: none"> ① Den Netzschalter einschalten und den Tonarm durch Drücken der Start-Taste gegen die Plattenmitte bewegen. ② Die Lifttaste drücken und überprüfen, daß der Abstand zwischen der Tonabnehmer-Nadelspitze und Führungsschiene ca. 26mm beträgt. ③ Falls der Abstand nicht korrekt ist, die Lifthöhe durch Drehen der Justierschraube mit einem Flachkopf-Schraubenzieher justieren. 	<p>– Bei zu großem Abstand: im Uhrzeigersinn drehen (> 26mm).</p> <p>– Bei zu kleinem Abstand: entgegen dem Uhrzeigersinn drehen (< 26mm).</p> <p>Anmerkung: Die Lifthöhe-Justierschraube des Ersatztonarms ist vollständig angezogen. Die Justierschraube ist daher vor dem Durchführen obiger Justierung zu lösen.</p>
2	Reibungswinkel-Justierung des Tonarms (Siehe Abb. B)	<ol style="list-style-type: none"> ① Den Netzschalter einschalten und den Tonarm durch Drücken der Start-Taste gegen die Plattenmitte bewegen. ② Überprüfen, daß die Tonarmmitte mit der V-Kerbe des Liftachse übereinstimmt. 	<ol style="list-style-type: none"> ③ Überprüfen, daß der Tonarmträger parallel zum Tonarm ist. (Den Abstand zwischen A und B Abb. B. überprüfen.) ④ Falls der Tonarmträger nicht parallel zum Tonarm ist, durch Drehen der Reibungswinkel-Justierschraube justieren.
3	Justierung der Tonarm-Empfindlichkeit	<ol style="list-style-type: none"> ① Den Netzschalter einschalten und den Tonarm durch Drücken der Start-Taste gegen die Plattenmitte bewegen. ② Die Lifttaste drücken und überprüfen, daß der Tonarm abgesenkt wird. ③ Den Gleichstromvoltmeter an den Steckerstift im Justierloch der Rückseite anschließen. (Siehe Abb. C) ④ Die Spannungswerte bei der Position des Tonarms ganz rechts, bzw. ganz links, ablesen. (Siehe Abb. D und E) 	<ol style="list-style-type: none"> ⑤ Vom Unterschied zwischen den beiden Spannungswerten die Mittelspannung berechnen. Zum Beispiel, wenn die Spannung in Abb. D 15V, und in Abb. E), 0.02V beträgt: $\frac{(15V - 0.02V)}{2} + 0.02V = 7.49V$ (Mittelpunkt-Spannung) ⑥ Den Tonarm in die Mittelposition stellen, und die Justierschraube der Armbasis mit dem Sechskantschlüssel drehen, bis die Mittenspannung erreicht wird. (Siehe Abb. F)
4	Servo-Verstärkungs- und Reibungswinkel-Justierung	<p>Justierung mit Entfernen der Staubabdeckung: (Siehe Abb. G)</p> <ol style="list-style-type: none"> ① Den Netzschalter einschalten, und den Tonarm durch Drücken der Start-Taste gegen die Plattenmitte bewegen. ② Die Lifttaste drücken und überprüfen, daß der Tonarm abgesenkt wird. ③ Den Gleichstromvoltmeter an den Steckerstift im Justierloch an der Rückseite anschließen. ④ Überprüfen, daß VR301 bis zum Anschlag im Uhrzeigersinn gedreht worden ist. ⑤ VR302 drehen, bis der Gleichstromvoltmeter 0.72V anzeigt. (Servo-Verstärkungs-Justierung) ⑥ Die Platte mit 1mm-Rillenabstand auf dem Plattenspieler abspielen. ⑦ VR301 drehen, bis der Gleichstromvoltmeter 0.6V anzeigt. (Ausgleichsjustierung) 	<p>Justierung ohne Entfernen der Staubabdeckung: (Siehe Abb. H)</p> <ol style="list-style-type: none"> ① Eine Schallplatte auf den Plattenteller auflegen. ② Die Staubabdeckung 1 oder 2cm öffnen, den Netzschalter einschalten, und den Tonarm absenken. (In diesem Fall darauf achten, daß Abtastnadel die Platte nicht berührt.) ③ Den Gleichstromvoltmeter an den Steckerstift im Justierloch an der Rückseite anschließen. ④ Überprüfen, daß VR301 bis zum Anschlag im Uhrzeigersinn gedreht worden ist. ⑤ VR302 drehen, bis der Gleichstromvoltmeter 0.72V anzeigt. (Servo-Verstärkungs-Justierung) ⑥ Die Platte mit 1mm-Rillenabstand auf den Plattenteller auflegen, die Staubabdeckung schließen, und die Platte abspielen. ⑦ VR301 drehen, bis der Gleichstromvoltmeter 0.6V anzeigt. (Ausgleichsjustierung)

Mise au point du positionnement du démarrage automatique et de retour automatique

Positionnement du démarrage automatique

(S'assurer d'utiliser un disque de 30cm pour la mise au point.)

1. Retirer la plaque de surface. (Se référer à "Comment enlever la plaque de surface.")
2. S'assurer que le bras de lecture est sur la position de démarrage (position de l'accoudoir du bras de lecture).
3. Exécuter la mise au point en tournant la vis de réglage de positionnement du démarrage automatique. (Voir la photo 13.)

- Si le bras de lecture s'abaisse en franchissant la position de démarrage, tourner la vis de réglage dans le sens des aiguilles d'une montre.
 - Si le bras de lecture s'abaisse avant d'atteindre la position de démarrage, tourner la vis de réglage dans le sens inverse des aiguilles d'une montre.
4. Après la mise au point, se rappeler de bloquer la vis de réglage.

Positionnement du retour automatique

(S'assurer d'utiliser un disque de 17cm pour la mise au point.)

1. Retirer la plaque de surface. (Se référer à "Comment enlever la plaque de surface.")
2. Exécuter la mise au point en introduisant un tournevis à tête plate dans l'orifice de réglage. (Voir photo 13.)

- Si le bras de lecture revient avant la fin de l'audition, tourner le tournevis dans le sens des aiguilles d'une montre.
- Si le bras de lecture ne revient pas, même après la fin de l'audition, tourner le tournevis dans le sens inverse des aiguilles d'une montre.

Mettre au point la force verticale d'appui de la pointe de lecture dans les cas suivants. (Voir Fig. 11)

La force verticale d'appui de la pointe de lecture est normalement réglée sur 1.25 gramme, mais elle peut être augmentée ou diminuée de ± 0.25 gramme.

Il pourra être nécessaire d'augmenter la force verticale d'appui de la pointe lorsqu'on joue des disques enregistrés à des niveaux élevés, ou lorsque la température de la pièce est trop basse, ou encore lorsque l'appareil capte facilement des vibrations extérieures.

Cela aidera à empêcher une distorsion et un sautellement des sillons. Pour régler cette force verticale d'appui de la pointe de lecture, tourner la vis de réglage d'un côté ou de l'autre, comme il est montré sur le schéma. La vis est couplée avec la bague graduée.

Nota:

Ne pas tourner la vis de réglage de la force verticale d'appui de la pointe de lecture plus que les limites de réglage admissibles (1.5 ~ 1.0 g).

Mise au point du décalage du bras de lecture et de l'amplification servomécanique

Après la révision du bras de lecture et du circuit d'entraînement du bras, exécuter la mise au point suivante selon la procédure ci-dessous:

Outils et équipement à utiliser

1. DC VTVM ou vérificateur
2. Disque de 1mm d'écart
3. Tournevis à tête plate (petit)
4. Tournevis à tête plate Philips (petit)
5. Clef hexagonal (1.5M)

Condition du réglage

1. Retirer le couvercle de protection et la plaque de surface. (Se référer à la "Méthode de réglage.")
2. Placer la manette sélectrice de diamètre du disque sur la position de 30cm.
3. Mettre en marche le commutateur du couvercle (S305) en appuyant dessus avec un ruban. (Voir photo 14.)
4. Retirer l'étiquette sur l'arrière du couvercle. (Voir photo 15.)
5. Ouvrir complètement le boîtier supérieur et s'assurer que le bras de lecture fonctionne lorsqu'on appuie sur la touche de démarrage.

Etape	Article	Méthode de réglage	
1	Mise au point de la hauteur d'élévation (Voir Fig. A.)	<ol style="list-style-type: none"> ① Mettre en marche l'interrupteur d'alimentation et déplacer le bras de lecture vers le centre du disque en appuyant sur la touche de démarrage. ② Appuyer sur la touche de pose/relevage pour vérifier si l'intervalle entre la pointe de lecture de la cellule pick-up et le rail de guidage est d' à peu près 26 mm. ③ Si l'intervalle n'est pas suffisant, ajuster la hauteur d'élévation en tournant la vis de réglage avec un tournevis à tête plate. 	<p>—Tourner dans le sens des aiguilles d'une montre si l'intervalle est excessif (> 26 mm).</p> <p>—Tourner dans le sens inverse des aiguilles d'une montre lorsque l'intervalle est insuffisant (< 26 mm).</p> <p>Nota: La vis de réglage de la hauteur d'élévation du bras de lecture de rechange est serrée à fond. Aussi, desserrer la vis de réglage avant de faire la mise au point ci-dessus.</p>
2	Mise au point de l'angle de décalage du bras de lecture (Voir Fig. B.)	<ol style="list-style-type: none"> ① Mettre en marche l'interrupteur d'alimentation et déplacer le bras de lecture vers le centre du disque en appuyant sur la touche de démarrage. ② S'assurer que le centre du bras soit aligné avec l'encoche en V de la tige d'élévation. 	<ol style="list-style-type: none"> ③ S'assurer que le socle du bras est parallèle au bras. (Vérifier l'intervalle entre A et B, dans la Fig. B.) ④ Si le socle du bras n'est pas parallèle au bras, l'ajuster en tournant la vis de réglage de l'angle de décalage.
3	Mise au point de la sensibilité du bras	<ol style="list-style-type: none"> ① Mettre en marche l'interrupteur d'alimentation et déplacer le bras de lecture vers le centre du disque en appuyant sur la touche de démarrage. ② Appuyer sur la touche de pose/relevage et s'assurer que le bras est abaissé. ③ Brancher la DC VTVM à la broche du connecteur dans l'orifice de mise au point du couvercle arrière. (Voir la Fig. C.) ④ Observer les valeurs de la tension avec le bras de lecture complètement orienté vers la droite puis vers la gauche. (Voir les Figs. D et E.) 	<ol style="list-style-type: none"> ⑤ Calculer la tension moyenne provenant de la différence entre les deux valeurs de tension. Par exemple, lorsque la tension est de 15V dans la Fig. D et de 0.02V dans la Fig. E, puis: $\frac{(15V - 0.02V)}{2} + 0.02V = 7.49V$ (tension du point médian). ⑥ Placer le bras de lecture sur la position du centre et tourner la vis de réglage du socle du bras avec une clef hexagonale jusqu' à ce que la tension médiane soit obtenue. (Voir Fig. F.)
4	Mise au point du décalage et de l'amplification servomécanique	<p>Ajustement en retirant le couvercle de protection. (Voir Fig. G.)</p> <ol style="list-style-type: none"> ① Mettre en marche l'interrupteur d'alimentation et déplacer le bras de lecture vers le centre du disque en appuyant sur la touche de démarrage. ② Appuyer sur la touche de pose/relevage et s'assurer que le bras de lecture est abaissé. ③ Brancher le DC VTVM à la broche du connecteur dans l'orifice de mise au point du couvercle arrière. ④ S'assurer que VR301 a été entièrement tourné dans le sens des aiguilles d'une montre. ⑤ Tourner VR302 jusqu' à ce que le DC VTVM indique 0.72V. (Mise au point de l'amplification servomécanique.) ⑥ Faire jouer sur la platine un disque de 1mm d' écart. ⑦ Tourner VR301 jusqu' à ce que la DC VTVM indique 0.6V. (Mise au point du décalage.) 	<p>Ajustement sans retirer le couvercle de protection (Voir Fig. H.)</p> <ol style="list-style-type: none"> ① Placer un disque sur la platine. ② Ouvrir le couvercle de protection de 1 à 2 cm, mettre en marche l'interrupteur d'alimentation et abaisser le bras de lecture. (Dans ce cas, ne pas laisser la pointe de lecture toucher le disque.) ③ Brancher la DC VTVM à la broche du connecteur dans l'orifice de mise au point du couvercle arrière. ④ S'assurer que VR301 a été entièrement tournée dans le sens des aiguilles d'une montre. ⑤ Tourner VR302 jusqu' à ce que le DC VTVM indique 0.72V. (Mise au point de l'amplification servomécanique.) ⑥ Placer un disque de 1 mm d'écart sur la platine, refermer le couvercle de protection et faire jouer le disque. ⑦ Tourner VR301 jusqu' à ce que le DC VTVM indique 0.6V. (Mise au point de décalage.)

REPLACEMENT PARTS LIST...Electric Parts

- Notes:**
1. Part numbers are indicated on most mechanical parts. Please use this part number for parts orders.
 2. **▲** indicates that only parts specified by the manufacturer be used for safety.

3. Bracketed indications in Ref. No. columns specify the area. Parts without these indications can be used for all areas.

Ref. No.	Part No.	Part Name & Description
INTEGRATED CIRCUITS		
IC1	SVIUPC7812H	IC, Regulator
IC2	SVIUPC78M05H	IC, Regulator
IC101	AN6635	IC, Drive
IC201	AN6680	IC, Control
IC301	MN1400PA	IC, Micro Computer
IC302	SVITC4069	IC, Inverter
IC303	SVIM53217P	IC, Buffer
IC304	SVIM53216P	IC, Buffer
TRANSISTORS		
Q101	2SB641	Transistor
Q102, 104	2SD636	Transistor
Q103, 105	2SD638	Transistor
Q201, 203	2SD636	Transistor
Q202	2SC1328-T	Transistor
Q301, 302	2SD636	Transistor
307, 308, 313 ~ 315		
320 ~ 323		
Q303 ~ 305	SVTPH101-Q2	Photo Transistor
Q306	2SB643	Transistor
Q309, 310	2SA885	Transistor
Q311, 312	2SC1846-R	Transistor
Q316, 317	2SD638	Transistor
Q318, 319	2SB641	Transistor
DIODES		
D1	▲ SVDS1RBA20Z	Rectifier
D101, 103, 104	MA162A	Diode
D102	20A90	Diode
D201, 202	MA162A	Diode
D203	SVDGD4205ALC	Light Emitting Diode, Strobe
D301 ~ 315	MA162A	Diode
D316 ~ 320	SVDPR5531K	Light Emitting Diode
D321 ~ 323	SVDAR3402S	Light Emitting Diode, Record Size Select
D324	MA26TO-A	Diode
D325	20A90	Diode
D401	SVDEBR3432S	Light Emitting Diode
D402	MA162A	Diode
PHOTO INTERRUPTERS		
PC301	ON1161	Photo Interrupter
PC302	ON1108	Photo Interrupter
HALL ELEMENT		
H1, H2	H-300A	Hall Element
CRYSTAL		
X201	SVQU306115	Crystal
RELAY		
RL1	SFDSC07-01	Relay, Muting
RL401	SFDZC07-01E	Plunger, Cueing
SWITCHES		
S1-1	▲ SFDSS5GLS	Switch, Power
S1-2	▲ SFDSTWM9901	Switch, Power
S3	▲ SFDSHXW01317	Switch, Power Select
S201	SFDSC10-01	Switch, Speed Select
S301, 302	EVQQBR08K	Switch, Start & Stop
S303, 304	EVQQXR04K	Switch, Repeat & Cueing
S305	ESB6247	Switch, Cover
S306, 307	SFDSA252461	Switch, End & Rest Detect

Ref. No.	Part No.	Part Name & Description
VARIABLE RESISTORS		
VR301	EVNM0AA00B14	Offset Adjustment, 10k Ω (B)
VR302	EVNM0AA00B13	Servo Gain Adjustment, 1k Ω (B)
FUSE		
F1, 2	▲ XBA2C10TR0	Fuse, 1A
F3	▲ XBAS2C025T1A	Fuse, 250mA
POWER TRANSFORMER		
T1	▲ SLT66PS1E	Power Transformer
RESISTORS		
R1	▲ ERD50TJ4R7	Carbon, 4.7 Ω , 1/2W, \pm 5%
R101	ERX1ANJ1R5	Metallic, 1.5 Ω , 1W, \pm 5%
R102	ERD25FJ562	Carbon, 5.6k Ω , 1/4W, \pm 5%
R103	ERD25FJ152	Carbon, 1.5k Ω , 1/4W, \pm 5%
R106	ERD25FJ271	Carbon, 270 Ω , 1/4W, \pm 5%
R107	ERD25TJ563	Carbon, 56k Ω , 1/4W, \pm 5%
R108, 109	ERD25FJ101	Carbon, 100 Ω , 1/4W, \pm 5%
R110	ERD25TJ473	Carbon, 47k Ω , 1/4W, \pm 5%
R111	ERD25TJ123	Carbon, 12k Ω , 1/4W, \pm 5%
R112, 113	ERD25FJ222	Carbon, 2.2k Ω , 1/4W, \pm 5%
R115	ERD25TJ223	Carbon, 22k Ω , 1/4W, \pm 5%
R116	ERD25TJ393	Carbon, 39k Ω , 1/4W, \pm 5%
R117	ERG1ANJ470	Metal Oxide, 47 Ω , 1W, \pm 5%
R118	ERD25FJ102	Carbon, 1k Ω , 1/4W, \pm 5%
R119	ERD25TJ563	Carbon, 56k Ω , 1/4W, \pm 5%
R201	ERD25FJ331	Carbon, 330 Ω , 1/4W, \pm 5%
R202	ERD25FJ222	Carbon, 2.2k Ω , 1/4W, \pm 5%
R203	ERD25FJ470	Carbon, 47 Ω , 1/4W, \pm 5%
R204	ERD25FJ272	Carbon, 2.7k Ω , 1/4W, \pm 5%
R205	ERD25TJ124	Carbon, 120k Ω , 1/4W, \pm 5%
R206	ERD25FJ391	Carbon, 390 Ω , 1/4W, \pm 5%
R207	ERD25TJ273	Carbon, 27k Ω , 1/4W, \pm 5%
R208	ERD25TJ224	Carbon, 220k Ω , 1/4W, \pm 5%
R209	ERD25TJ823	Carbon, 82k Ω , 1/4W, \pm 5%
R210	ERD25FJ392	Carbon, 3.9k Ω , 1/4W, \pm 5%
R211	ERD25TJ563	Carbon, 56k Ω , 1/4W, \pm 5%
R212	ERD25TJ223	Carbon, 22k Ω , 1/4W, \pm 5%
R213	ERD25FJ103	Carbon, 10k Ω , 1/4W, \pm 5%
R214	ERD25FJ471	Carbon, 470 Ω , 1/4W, \pm 5%
R215	ERD25TJ683	Carbon, 68k Ω , 1/4W, \pm 5%
R216	ERD25FJ103	Carbon, 10k Ω , 1/4W, \pm 5%
R217	ERD25FJ471	Carbon, 470 Ω , 1/4W, \pm 5%
R218	ERD25FJ181	Carbon, 180 Ω , 1/4W, \pm 5%
R219	ERD25TJ223	Carbon, 22k Ω , 1/4W, \pm 5%
R220	ERD25FJ272	Carbon, 2.7k Ω , 1/4W, \pm 5%
R221	ERD25FJ181	Carbon, 180 Ω , 1/4W, \pm 5%
R301	ERD25FJ103	Carbon, 10k Ω , 1/4W, \pm 5%
R302	ERD25FJ102	Carbon, 1k Ω , 1/4W, \pm 5%
R303	ERD25FJ222	Carbon, 2.2k Ω , 1/4W, \pm 5%
R304	ERD25FJ150	Carbon, 15 Ω , 1/4W, \pm 5%
R305	ERD25FJ102	Carbon, 1k Ω , 1/4W, \pm 5%
R306, 307	ERD25FJ472	Carbon, 4.7k Ω , 1/4W, \pm 5%
R308, 309	ERD25FJ222	Carbon, 2.2k Ω , 1/4W, \pm 5%
R310, 311	ERD25TJ473	Carbon, 47k Ω , 1/4W, \pm 5%
R312	ERD25FJ472	Carbon, 4.7k Ω , 1/4W, \pm 5%
R313, 314	ERD25TJ223	Carbon, 22k Ω , 1/4W, \pm 5%
R315, 316	ERD25TJ223	Carbon, 22k Ω , 1/4W, \pm 5%
R317	ERD25TJ473	Carbon, 47k Ω , 1/4W, \pm 5%
R318	ERD25FJ472	Carbon, 4.7k Ω , 1/4W, \pm 5%
R319	ERD25FJ222	Carbon, 2.2k Ω , 1/4W, \pm 5%
R320	ERD25FJ103	Carbon, 10k Ω , 1/4W, \pm 5%
R321, 322	ERD25FJ472	Carbon, 4.7k Ω , 1/4W, \pm 5%
R323	ERD25TJ124	Carbon, 120k Ω , 1/4W, \pm 5%
R324	ERD25FJ101	Carbon, 100 Ω , 1/4W, \pm 5%

Ref. No.	Part No.	Part Name & Description			
R325	ERD25FJ681	Carbon,	680Ω,	1/4W,	± 5%
R326	ERD25FJ102	Carbon,	1kΩ,	1/4W,	± 5%
R327	ERD25FJ681	Carbon,	680Ω,	1/4W,	± 5%
R328, 329	ERD25FJ471	Carbon,	470Ω,	1/4W,	± 5%
R330, 331	ERD25FJ102	Carbon,	1kΩ,	1/4W,	± 5%
R332, 333	ERD25FJ222	Carbon,	2.2kΩ,	1/4W,	± 5%
R334, 335	ERD25FJ472	Carbon,	4.7kΩ,	1/4W,	± 5%
R336	ERD25FJ181	Carbon,	180Ω,	1/4W,	± 5%
R337	ERD25TJ333	Carbon,	33kΩ,	1/4W,	± 5%
R338	ERD25FJ121	Carbon,	120Ω,	1/4W,	± 5%
R339	ERD25FJ681	Carbon,	680Ω,	1/4W,	± 5%
R340	ERD25TJ223	Carbon,	22kΩ,	1/4W,	± 5%
R341	ERD25TJ393	Carbon,	39kΩ,	1/4W,	± 5%
R342	ERD25FJ103	Carbon,	10kΩ,	1/4W,	± 5%
R343	ERD25FJ222	Carbon,	2.2kΩ,	1/4W,	± 5%
R344	ERG1ANJ121	Metal Oxide,	120Ω,	1W,	± 5%
R345, 346	ERD25FJ271	Carbon,	270Ω,	1/4W,	± 5%
R347, 348	ERD25FJ271	Carbon,	270Ω,	1/4W,	± 5%
R349	ERD25FJ271	Carbon,	270Ω,	1/4W,	± 5%
R350, 351	ERD25TJ124	Carbon,	120kΩ,	1/4W,	± 5%
R353, 354	ERD25FJ472	Carbon,	4.7kΩ,	1/4W,	± 5%
R355	ERD25TJ473	Carbon,	47kΩ,	1/4W,	± 5%
R356, 357	ERD25TJ223	Carbon,	22kΩ,	1/4W,	± 5%
R358	ERD25FJ102	Carbon,	1kΩ,	1/4W,	± 5%
R359	ERD25TJ393	Carbon,	39kΩ,	1/4W,	± 5%
R360	ERD25TJ223	Carbon,	22kΩ,	1/4W,	± 5%
R361	ERD25FJ103	Carbon,	10kΩ,	1/4W,	± 5%
R362	ERD25FJ471	Carbon,	470Ω,	1/4W,	± 5%
R364	ERD25FJ681	Carbon,	680Ω,	1/4W,	± 5%
R365	ERD25FJ272	Carbon,	2.7kΩ,	1/4W,	± 5%
R401, 402	ERD25FJ471	Carbon,	470Ω,	1/4W,	± 5%
CAPACITORS					
C1, 2	ECKD1H223PF	Ceramic,	0.022μF,	50V,	+ 100%
C3	ECEB1VS102	Electrolytic,	1000μF,	35V	- 8%
C4 [EG],[EB],[EF],[XA]	Δ ECQE2A473MZ	Polyester,	0.047μF,	250V,	± 20%
C4 [XL],[E],[EK]	Δ ECNC4A473MD	Ceramic,	0.047μF,	450V,	± 20%

Ref. No.	Part No.	Part Name & Description			
C5, 6	ECQM1H104KZ	Polyester,	0.1μF,	50V,	± 10%
C101, 102	ECQM1H104KZ	Polyester,	0.1μF,	50V,	± 10%
C103	ECQM1H104KZ	Polyester,	0.1μF,	50V,	± 10%
C104, 105	ECEA1CS330	Electrolytic,	33μF,	16V	
C106	ECEA1ES470	Electrolytic,	47μF,	25V	
C107	ECEA50Z3R3	Electrolytic,	3.3μF,	50V	
C108	ECEA1ES101	Electrolytic,	100μF,	25V	
C109	ECEA1ES101	Electrolytic,	100μF,	25V	
C201	ECEA1CS330	Electrolytic,	33μF,	16V	
C202, 203	ECEA50Z1	Electrolytic,	1μF,	50V	
C204	ECQM1H473KZ	Polyester,	0.047μF,	50V	± 10%
C205	ECEA50Z1	Electrolytic,	1μF,	50V	
C206	ECEA1AS221	Electrolytic,	220μF,	10V	
C207	ECEA1ES470	Electrolytic,	47μF,	25V	
C208	ECEA50Z1	Electrolytic,	1μF,	50V	
C209	ECQV05224JZ	Polyester,	0.22μF,	50V,	± 5%
C210	ECEA25Z4R7	Electrolytic,	4.7μF,	25V	
C211	ECQV05224JZ	Polyester,	0.22μF,	50V,	± 5%
C212	ECEA1ES101	Electrolytic,	100μF,	25V	
C213	ECEA1ES470	Electrolytic,	47μF,	25V	
C214	ECKF1E104ZV	Ceramic,	0.1μF,	25V	+ 80%
C215	ECCD1H471K	Ceramic,	470pF,	50V,	- 20%
C216	ECCD1H151K	Ceramic,	150pF,	50V,	± 10%
C217	ECCD1H330K	Ceramic,	33pF,	50V,	± 10%
C218	ECKF1E104ZV	Ceramic,	0.1μF,	25V,	+ 80%
C219	ECEA1ES101	Electrolytic,	100μF,	25V	
C301	ECEA1ES101	Electrolytic,	100μF,	25V	
C302	ECQM1H473KZ	Polyester,	0.047μF,	50V	± 10%
C303	ECQM1H104KZ	Polyester,	0.1μF,	50V,	± 10%
C304	ECEA0JS471	Electrolytic,	470μF,	6.3V	
C305	ECEA1CS330	Electrolytic,	33μF,	16V	
C306	ECCD1H101K	Ceramic,	100pF,	50V,	± 10%
C307	ECQM1H102KZ	Polyester,	0.001μF,	50V,	± 10%
C308	ECEA1CS330	Electrolytic,	33μF,	16V	
C309	ECQM1H104KZ	Polyester,	0.1μF,	50V,	± 10%
C310, 311	ECQM1H103KZ	Polyester,	0.01μF,	50V,	± 10%
C312	ECEA50Z1	Electrolytic,	1μF,	50V	
C313	ECEA1ES220	Electrolytic,	22μF,	25V	
C314	ECEA1AS101	Electrolytic,	100μF,	10V	
C315, 316	ECKD1H102KB	Ceramic,	0.001μF,	50V,	± 10%

Areas

- * [E] is available in Scandinavia.
- * [EK] is available in United Kingdom.
- * [XL] is available in Australia.
- * [EB] is available in Belgium.
- * [EG] is available in European.
- * [EF] is available in France.
- * [XA] is available in Asia, Latin America, Middle East and Africa.

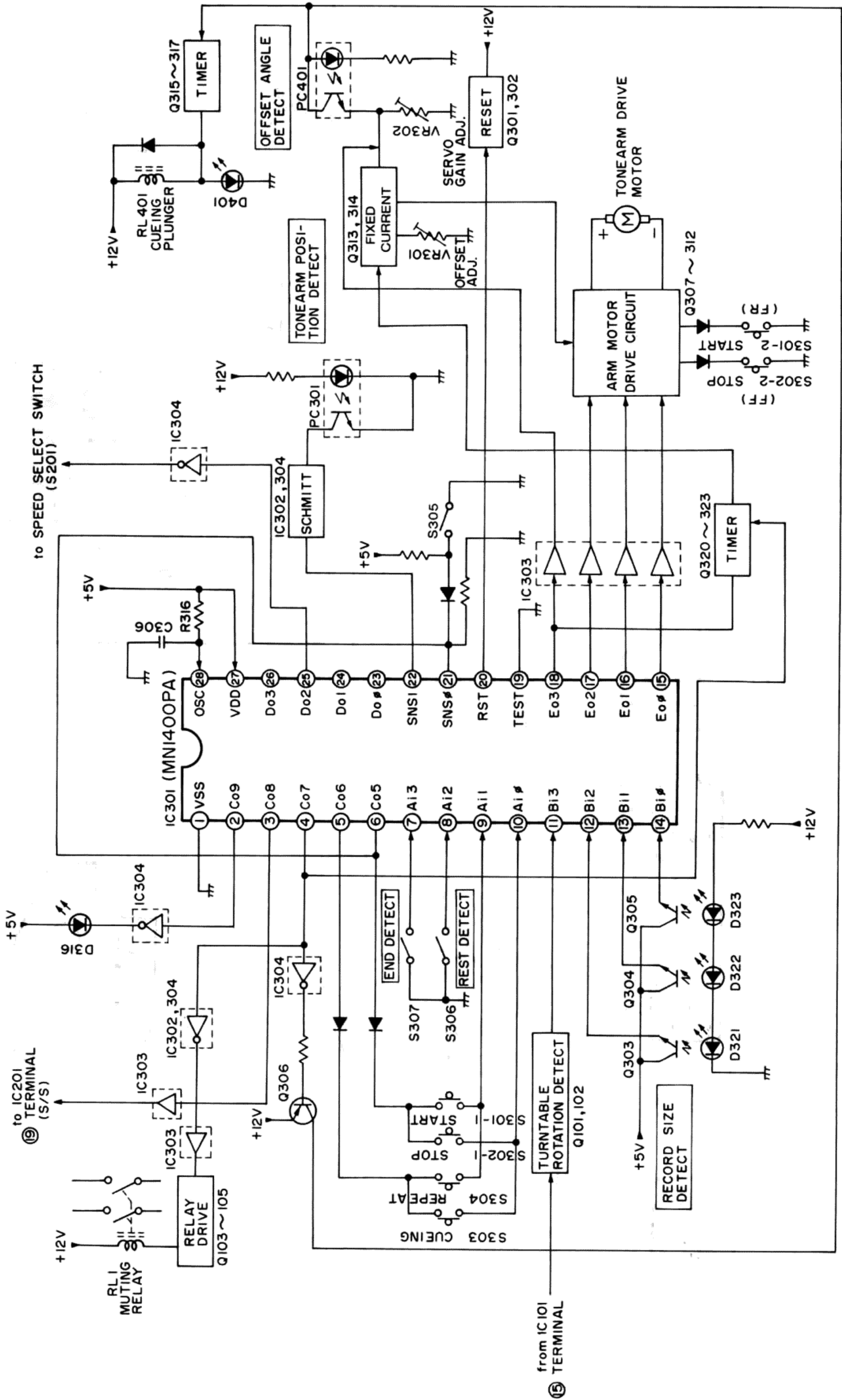

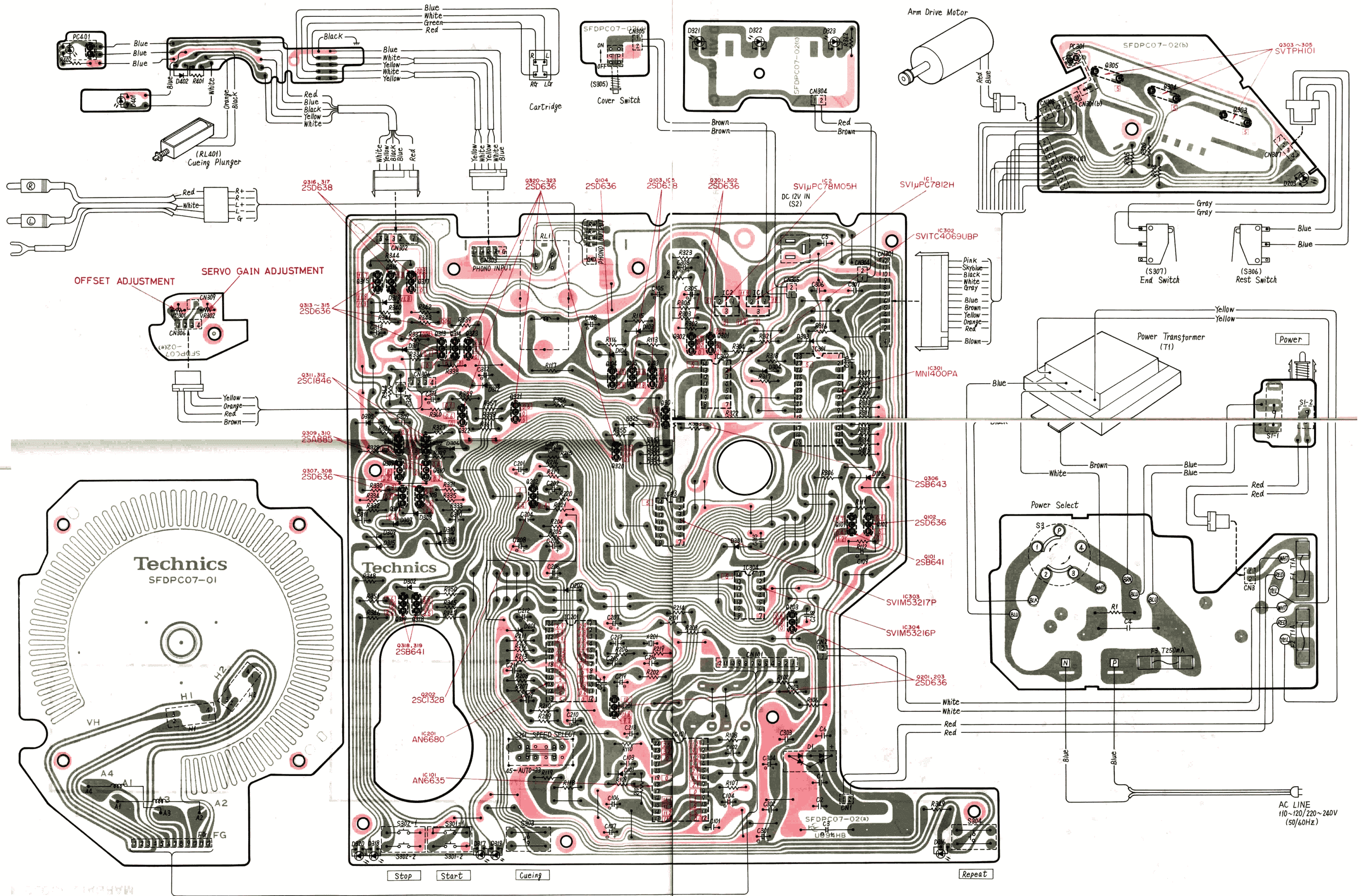

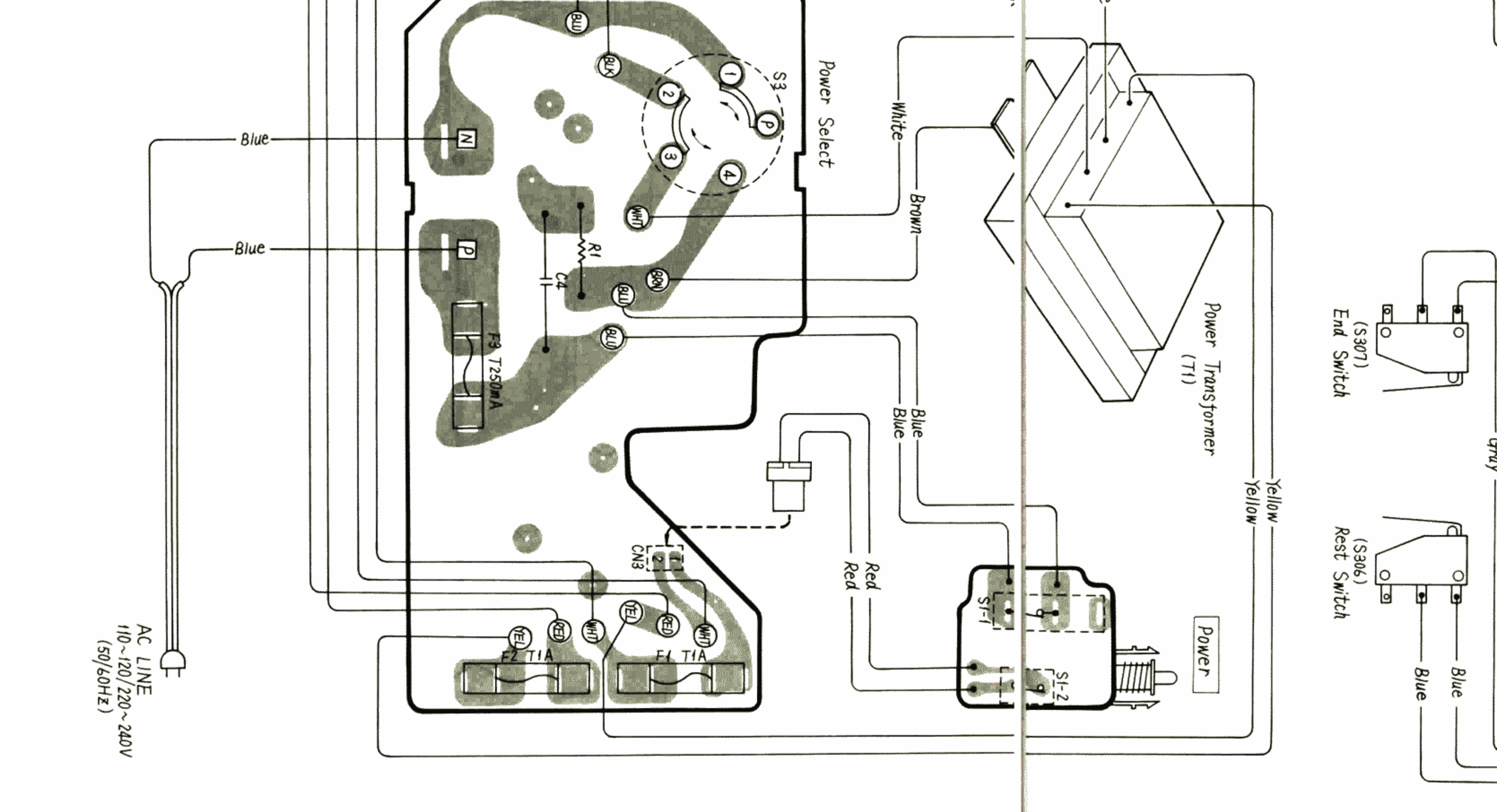
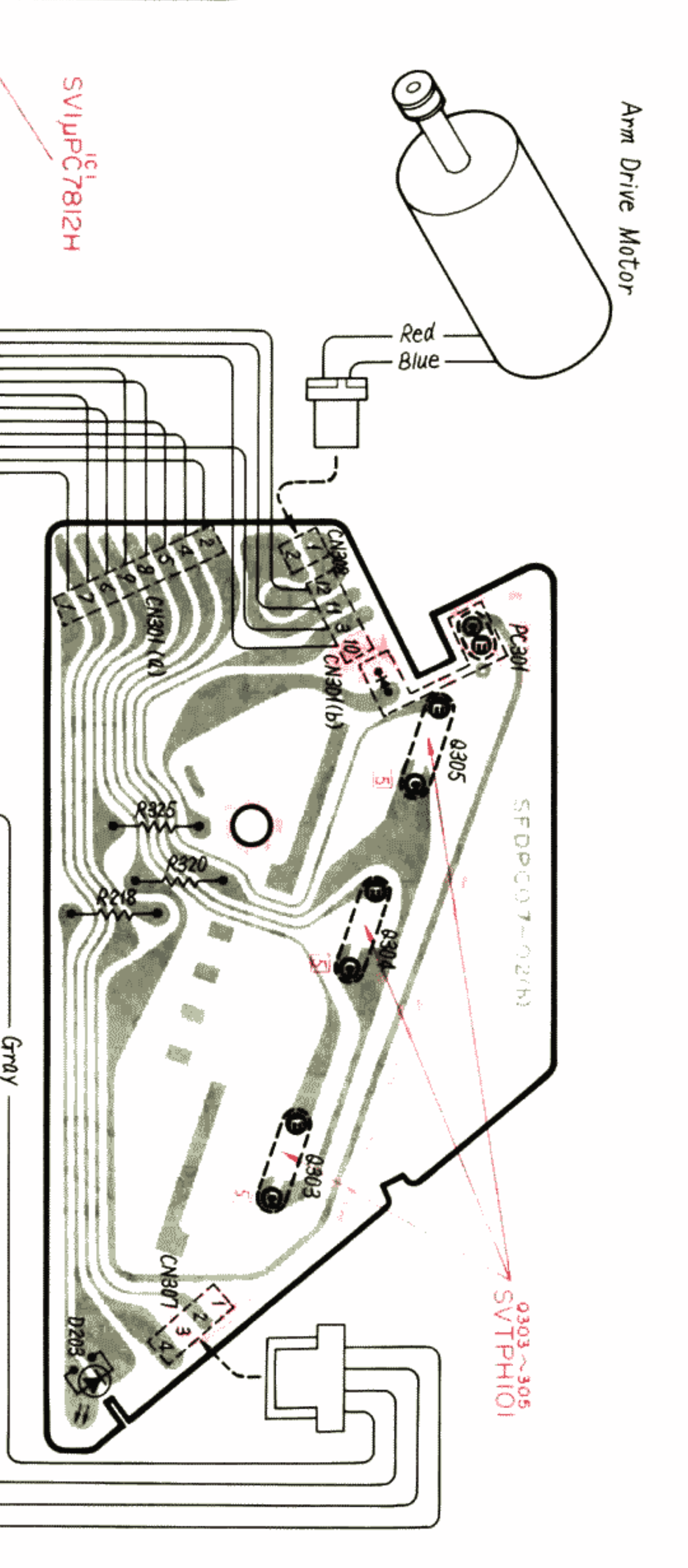
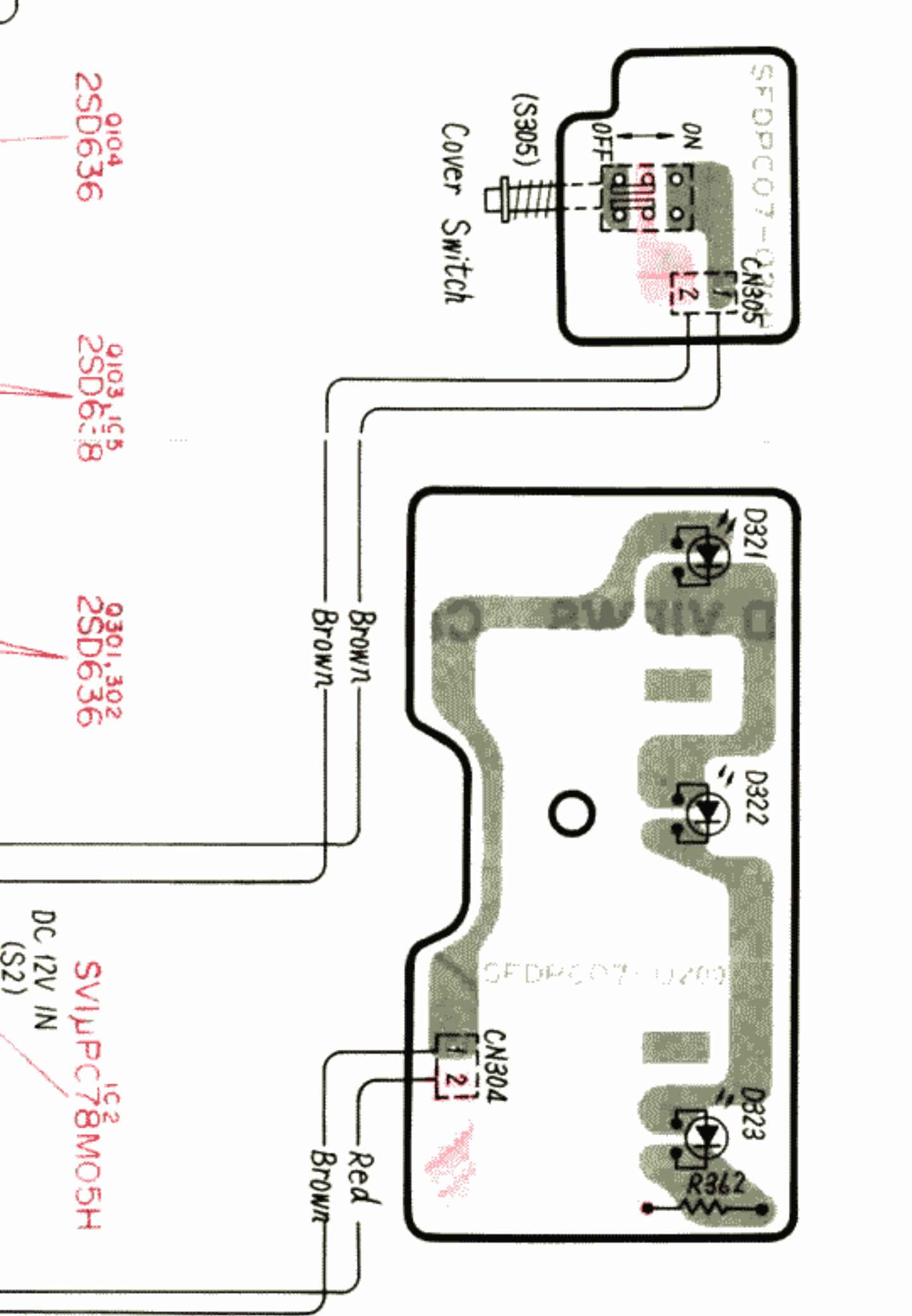
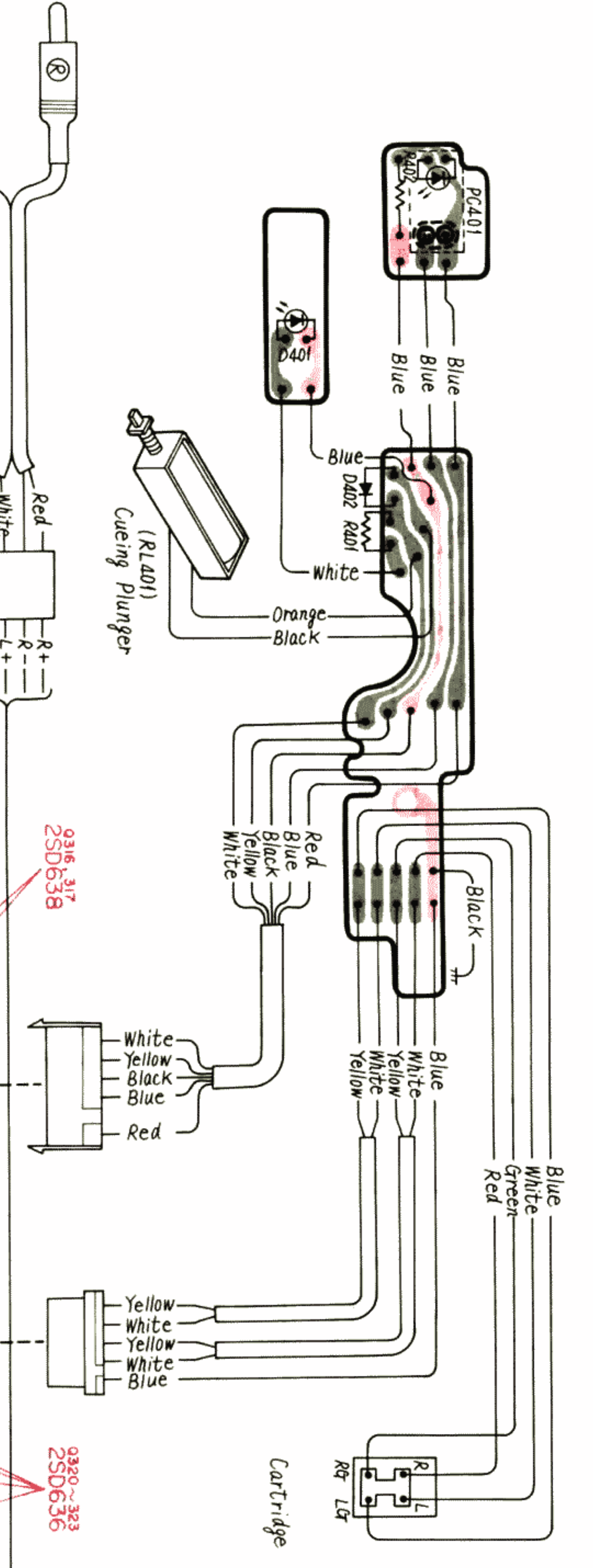
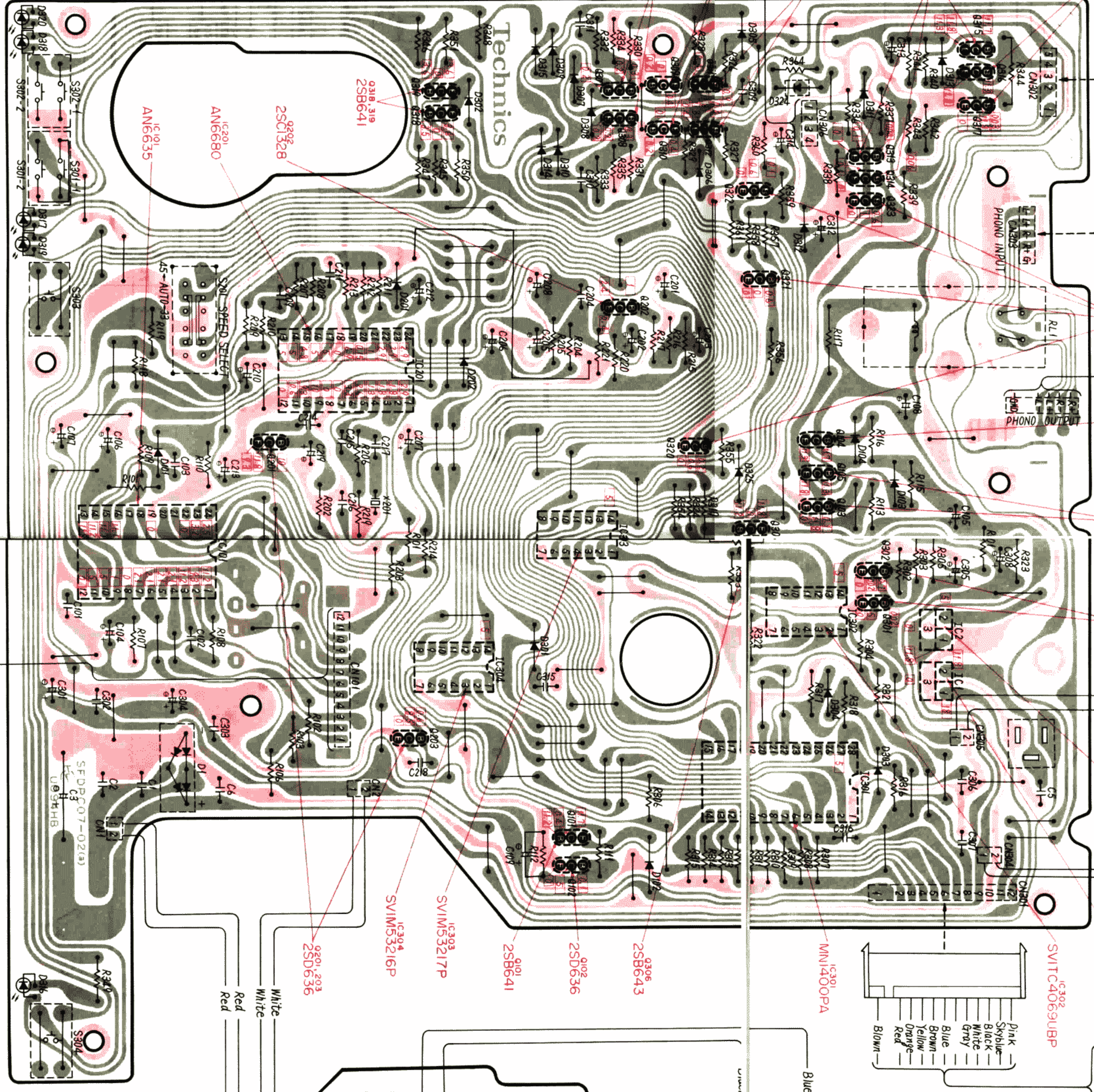
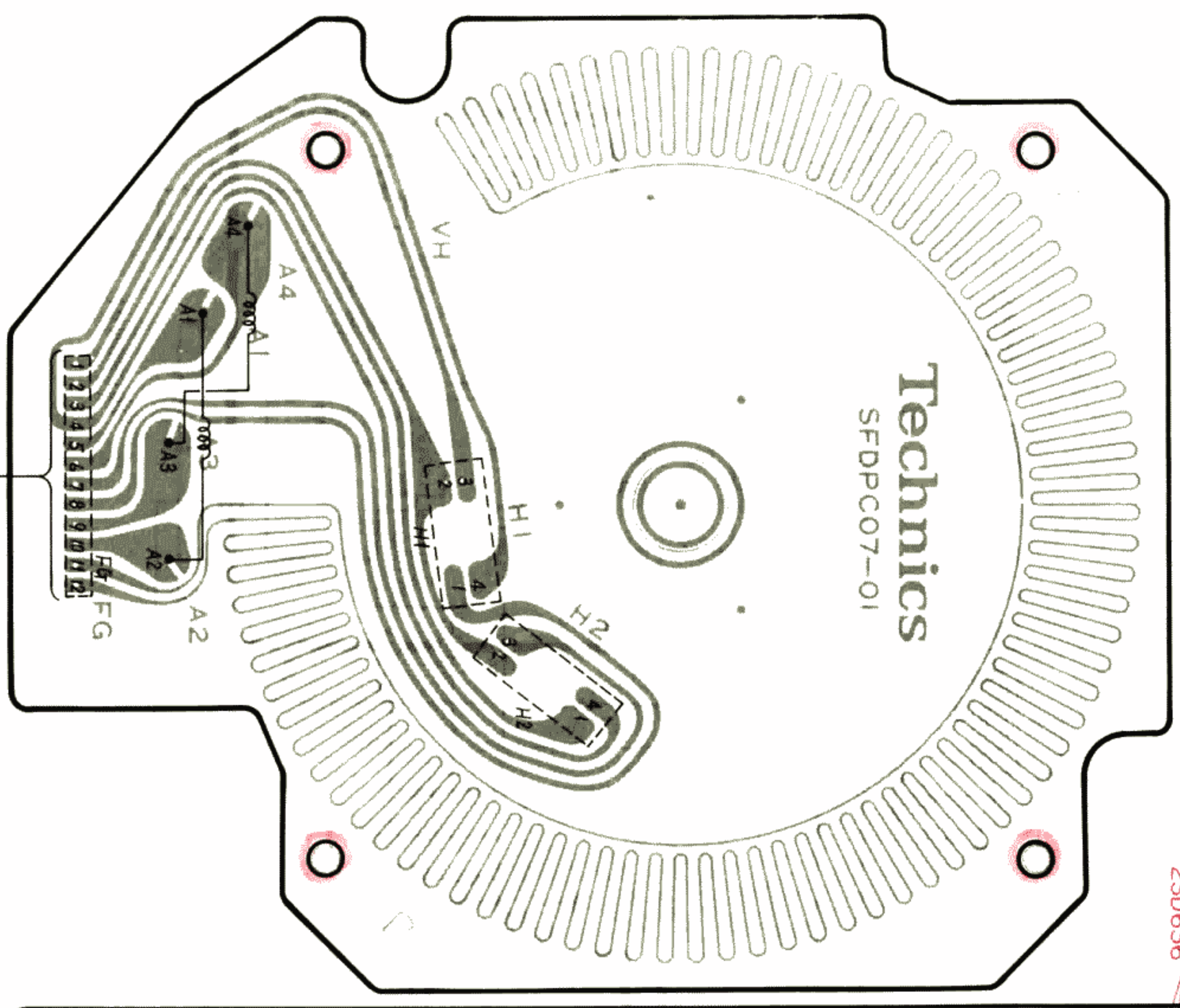
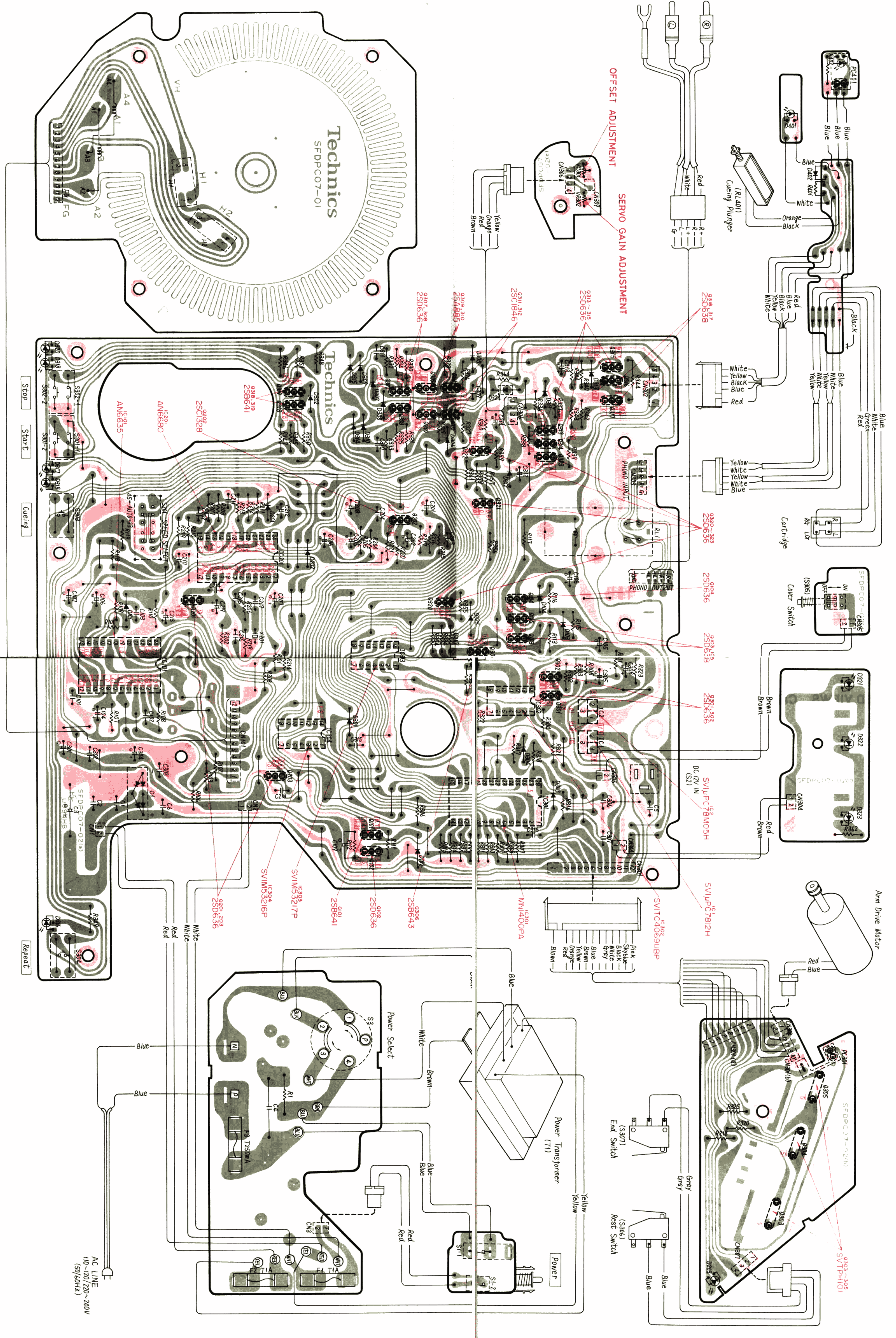

AC LINE
110-120/220-240V
(50/60Hz)

EXPLODED VIEWS...Cabinet and Chassis

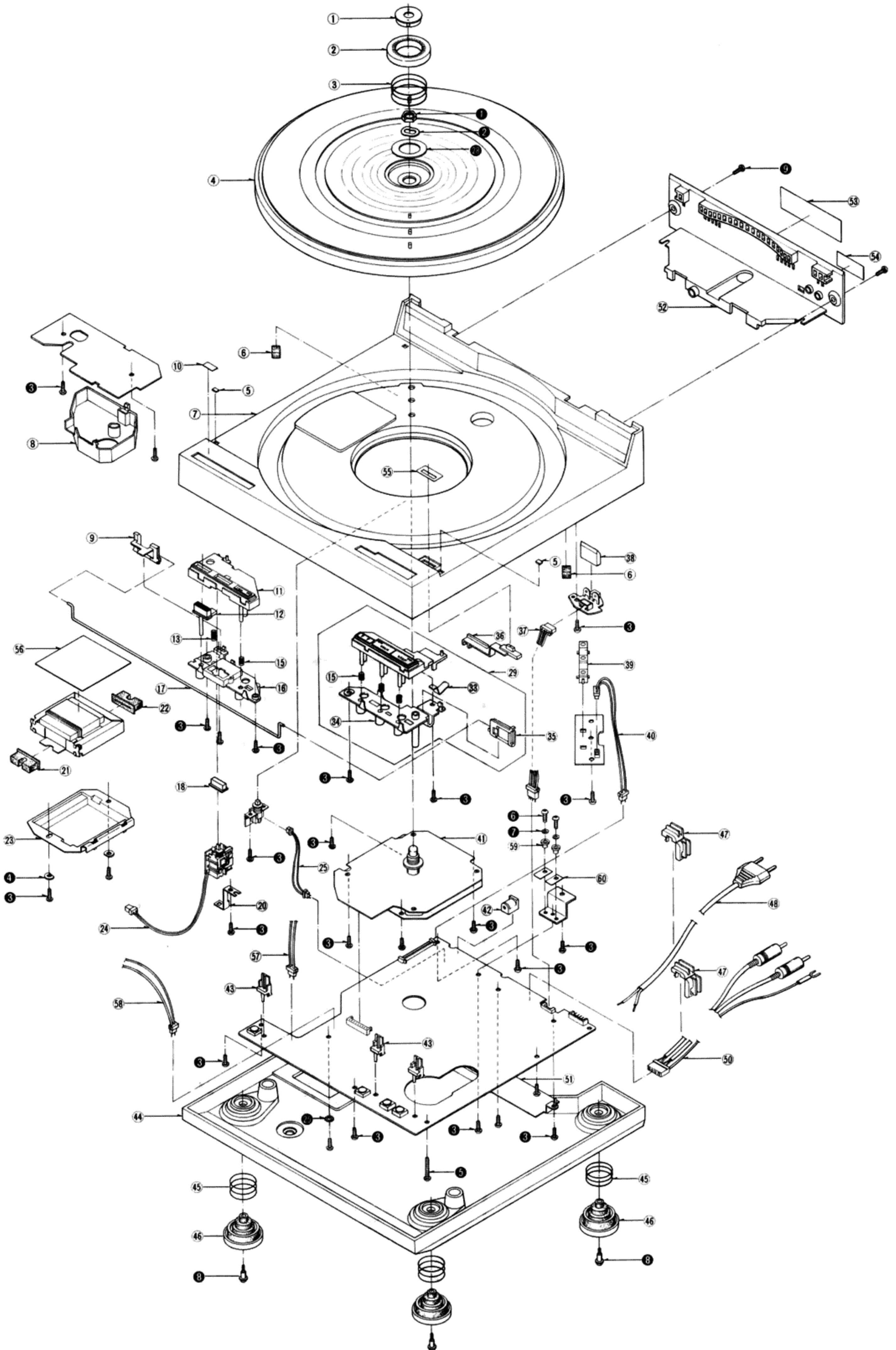

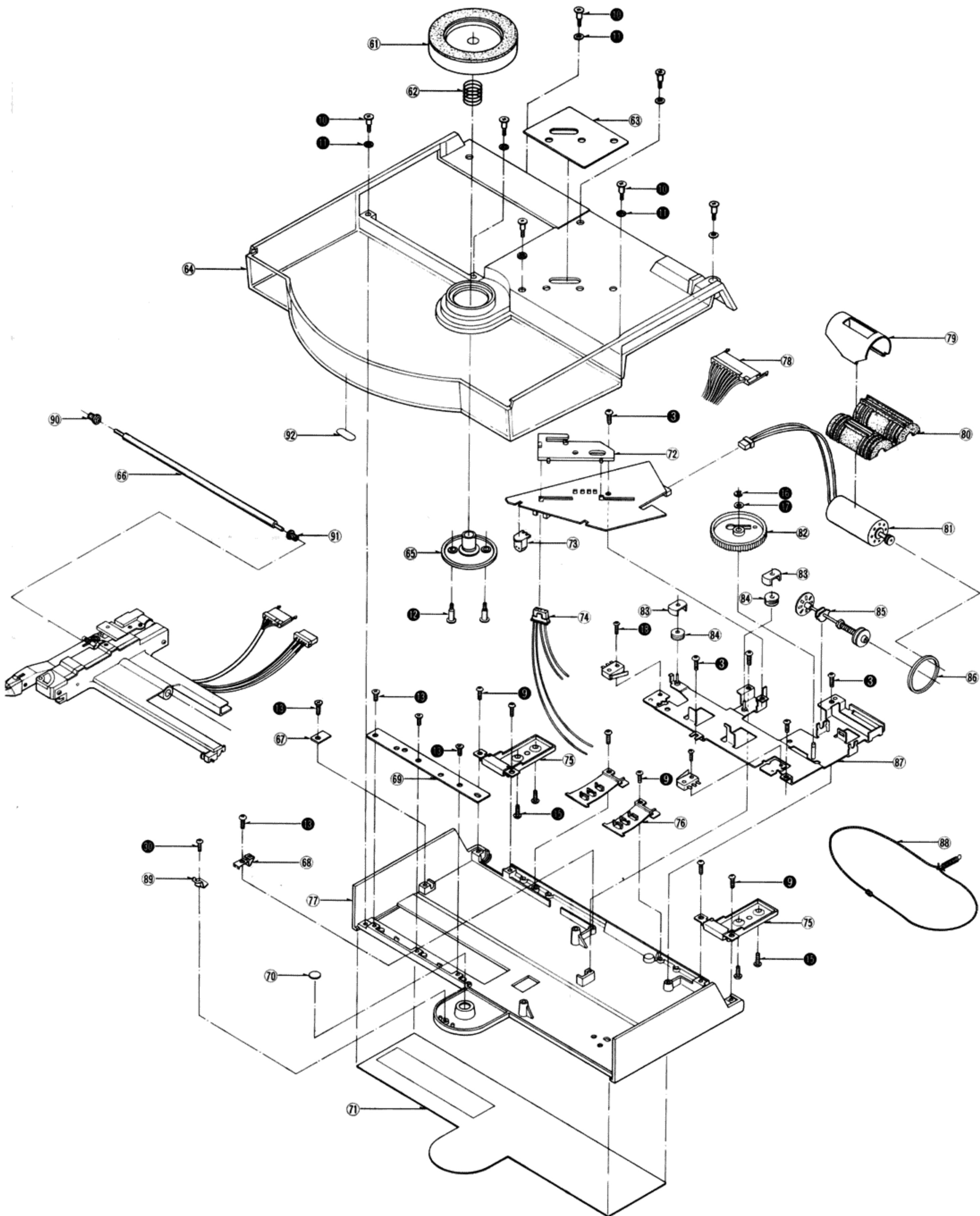

REPLACEMENT PARTS LIST...Cabinet & Chassis Parts

- Notes:**
1. Part numbers are indicated on most mechanical parts. Please use this part number for parts orders.
 2. Δ indicates that only parts specified by the manufacturer be used for safety.
 3. $\text{\textcircled{K}}$ -marked parts are used for black type only, while O-marked parts are for silver type only.
 4. Parts other than $\text{\textcircled{K}}$ and O-marked are used for both black and silver types.
 5. Bracketed indications in Ref. No. columns specify the area. Parts without these indications can be used for all areas.

Black type model No : SL-7 (K)

Ref. No.	Part No.	Part Name & Description
CABINET and CHASSIS PARTS		
1	SFUMC10-02	Supporter, 45 Adaptor
2	SFUMC10-01	45 Adaptor
3	SFQAC10-01	Spring, 45 Adaptor
4	SFTEC07-01A	Turntable
5	SFGCC07-02	Cushion, Dust Cover
6	SFGZC07-01	Spacer
7	O SFACC07-01	Cabinet
7	$\text{\textcircled{K}}$ SFACC07-21	Cabinet (Black)
8	SFUMC07X01	Cover, Power P.C.B.
9	SFUMC07-06	Guide (L), Lock Rod
10	SFNZC07-04	Label, Open
11	SFUMC07-17R	Guide, Power Switch
12	SFUMC07-04	Knob, Lock
13	SFQAC07-01	Spring, Lock
15	SFQAC07-02	Spring
16	SFUMC07-18	Guide (B), Power Switch
17	SFQSC07-01	Rod, Lock
18	SFKTC07-05	Knob, Power
20	SFUPC07-05	Bracket, Power Switch
21	SFGCC07-03	Cushion (A), Power Transformer
22	SFGCC07-06	Cushion (B), Power Transformer
23	SFUMC07-07	Cover, Power Transformer
24	SFDLC07-03E	Connector, 2 pin (with Wire)
25	SFDJC07-06E	Connector, 2 pin (with Wire)
29	SFUMC07-14A	Guide Ass'y, Operation
33	SFQPC07-01	Spacer, Lock Guide
34	SFUMC07-15	Guide (B), Operation
35	SFUMC07-05	Guide (R), Lock Rod
36	SFKTC07-06	Knob, Speed Select
37	SFDJC07-04E	Connector, 4 Pin (with Wire)
38	SFUMC07-21	Cover, VR301 & 302
39	SFUMC10-48	Spacer, Record Size L.E.D.
40	SFDJC07-05E	Connector, 2 Pin (with Wire)
41	SFMZC07-01Z	Stator Frame Ass'y
42	SFDJHEC0470	DC Terminal
43	SFUMC07-13	Spacer, L.E.D.
44	SFAUC07-01	Bottom Board
45	SFQCC07-01	Spring, Audio Insulator
46	SFGAC07-01E	Audio Insulator
47	SFUM190-11	Clamper, AC Cord
48	Δ SJA88	AC Cord
48 [EK] only	Δ QFC1205M	AC Cord
48 [XL] only	Δ QFC1208M	AC Cord
50	SFDHC07-01A	Phono Cord
51	SFUPC07-05	Plate, Shield
52	SFUMC07-03	Cover, Rear
53 [E] only	SFNNC07S01	Name Plate
53 [EK],[XL]	SFNNC07G01	Name Plate
53 [EG] only	SFNNC07N01	Name Plate
53 [EB],[EF]	SFNNC07J01	Name Plate
53 [XA] only	SFNNC07X01	Name Plate
54	SFNZC07-03	Lable, Adjustment
55	O SFNZC07-01	Lable, Speed Select
55	$\text{\textcircled{K}}$ SFNZC07-21	Lable, Speed Select (Black)
56	SFUPC07-10	Plate, Power Transformer
57	SFDLC07-02E	Connector, 2 Pin (with Wire)
58	SFDLC07-01E	Connector, 2 Pin (with Wire)
59	SFDBC07-01	Spacer, IC1 & IC2
60	SFDCC07-01	Spacer, IC1 & IC2
61	SFKDC07-01E	Supporter, Record
62	SFQAC07-03	Spring

Ref. No.	Part No.	Part Name & Description
63	SFNZC07M01	Lable, Record Size Select
64	SFADC07-01R	Dust Cover
65	SFUMC10-08E	Supporter, Record
66	SFXJC07-01	Guide Rail (A)
67	SFUPC07-04	Supporter
68	SFUPC07-07	Clamper, Wire
69	SFUPC07-03	Guide Rail (B)
70	SFXWC10-03	Spacer
71	SFKKC07-01	Panel
72	SFUMC07-16	Shutter
73	SFUMC10-48	Spacer, L.E.D. (Strobe)
74	SFDJC10-02E	Connector, 4 pin (with Wire)
75	O SFATC07-01A	Hinge
75	$\text{\textcircled{K}}$ SFATC07-21A	Hinge (Black)
76	SFUMC07-19	Guide, Wire
77	O SFACC07-02	Cabinet, Lid
77	$\text{\textcircled{K}}$ SFACC07-22	Cabinet, Lid (Black)
78	SFDJC07-01E	Connector, 12 pin
79	SFUPC07-02	Cover, Motor
80	SFGCC07-01	Cushion, Motor
81	SFMHC10-01E	Motor Ass'y
82	SFUMC10-05	Drum, Arm Drive
83	SFUMC07-22	Stopper
84	RDR20-3	Pulley
85	SFXZC07-01R	Worm Ass'y
86	SFGBC10-01	Belt
87	SFUPC07-01E	Plate, Arm Drive
88	SFUZC07-05E	Lope
89	SFUPC07-08	Bracket, Dust Cover
90	SFGCC07-05	Cushion (B), Guide Rail (A)
91	SFGCC07-04	Cushion (A), Guide Rail (A)
92	SFNZC07-06	Lable, Push

TONARM PARTS		
101	SFPAM00701A	Tonearm Ass'y
102	EPCP202CBK	Cartridge
	EPS202ED	Stylus
103	SFPCS00701A	Pointer Ass'y
104	SFPKD00701E	Arm Base
105	SFDZC07-01E	Plunger Ass'y (PL401)
106	SFPJL00701A	Lift Ass'y
107	SFPSP00704	Spring, Lift
108	SFPKD00702	Cover, Arm Base
109	SFPSP00706	Spring
110	SFDJC07-03E	Connector, Phono (with Wire)
111	SFDJC07-02E	Connector, 5 pin (with Wire)
112	SFPZB00702	Bracket

SCREWS, WASHERS and CIRCLIPS		
①	XNS12	Nut
②	SFXWC10-01	Washer
③	XTV3+8BFN	Screw
④	XWT3	Washer
⑤	XTN3+35B	Screw
⑥	XSN3+6S	Screw
⑦	XWA3B	Washer
⑧	SFXGQ20-01	Screw
⑨	XTN3+8BFZ	Screw
⑩	SFXGC07-01	Screw
⑪	SFXWC07-01	Washer
⑫	SFXGC10-02	Screw
⑬	XTS26+6JFZ	Screw

Ref. No.	Part No.	Part Name & Description
●	XTB3+6BFN	Screw
●	XUC3FT	Circlip
●	SFXW551D2	Washer
●	XYN23+C10BN	Screw
●	SFPEV00701	Screw
●	XTN3+4B	Screw
●	XTN23+6BFZ	Screw
●	XSN2+4BV	Screw
●	XWA2BFZ	Washer
●	SFPTN00702	Screw
●	XWC3B	Washer
●	XSN3+8S	Screw
●	XXE3D6FZ	Screw
●	SFSP00706	Screw
●	SFXWC10-05	Washer
●	XTN3+6BFZ	Screw
ACCESSORIES		
A1 [E] only	SFNUC07S01	Instruction Book
A1 [EK] only	SFNUC07G01	Instruction Book
A1 [EG],[EF],[EB],[XL],[XA]	SFNUC07X01	Instruction Book

Ref. No.	Part No.	Part Name & Description
A2	SFCZB30001	Brush
A3	SFWTC07-01	Screw Driver
A4 [XA] only	SFDKI19118	2P Plug
PACKING PARTS		
P1 [EF] only	○ SFHPC07C01	Carton
P1	○ SFHPC07M01	Carton
P1	⊗ SFHPC07M21	Carton (Black)
P2	SFHHC07-01	Pad (L)
P3	SFHHC07-02	Pad (R)
P4	SFHSC07-02	Spacer (A), Corner
P5	SFHSC07-03	Spacer (B), Corner
P6	SFHSC07-01	Spacer, Tonearm
P7	SFHSC10-01	Spacer, Turntable
P8	XSN4D20FYBS	Screw
P9	SFHZC07-01	Cover
P10	SFYH45X60	Polyethylene Bag, Unit
P11	SPP189	Polyethylene Bag, Cord
P12	SPB1083	Polyethylene Bag, Accessory

EXPLODED VIEWS... Tonearm

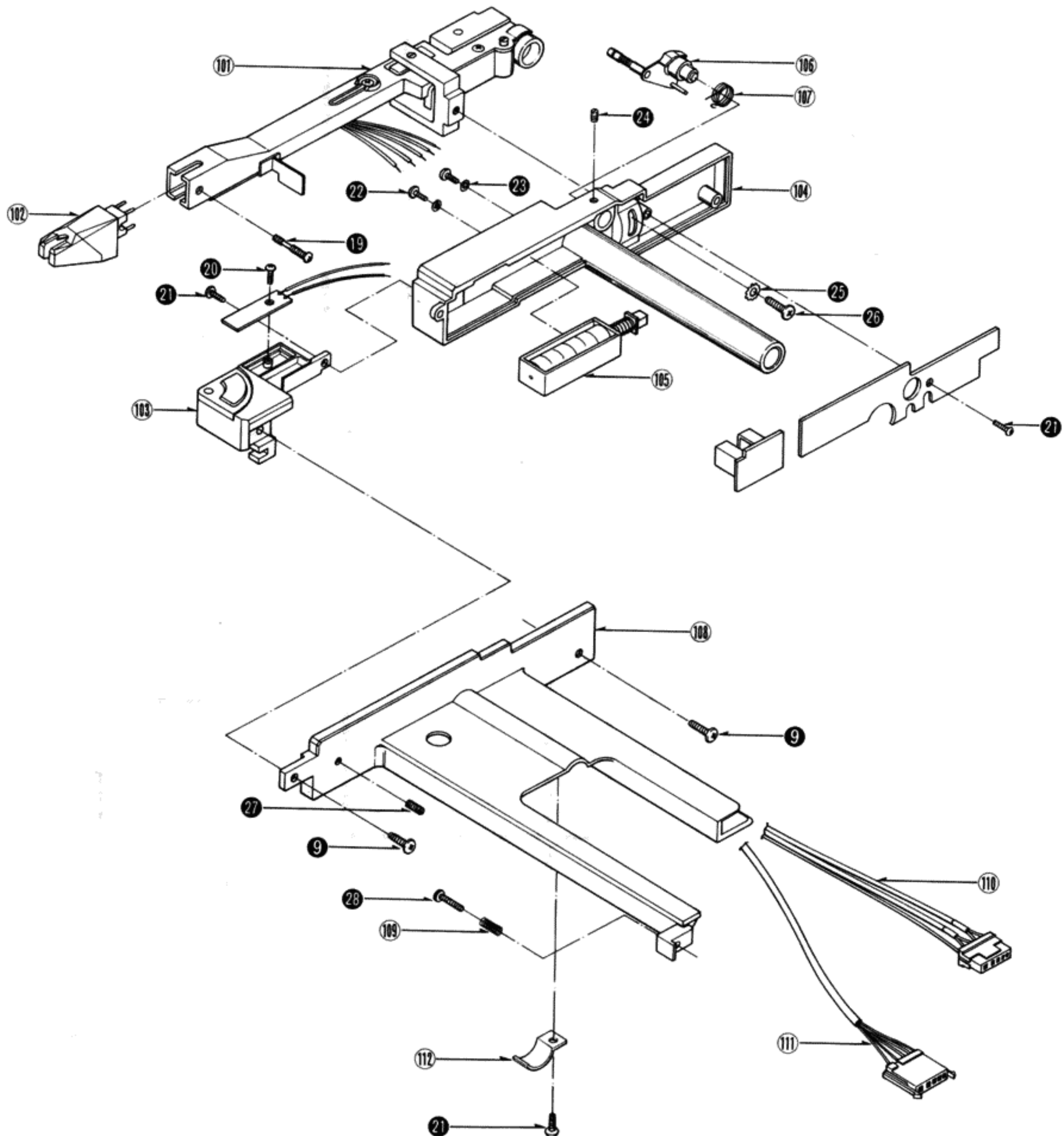

■ BLOCK DIAGRAM OF IC'S

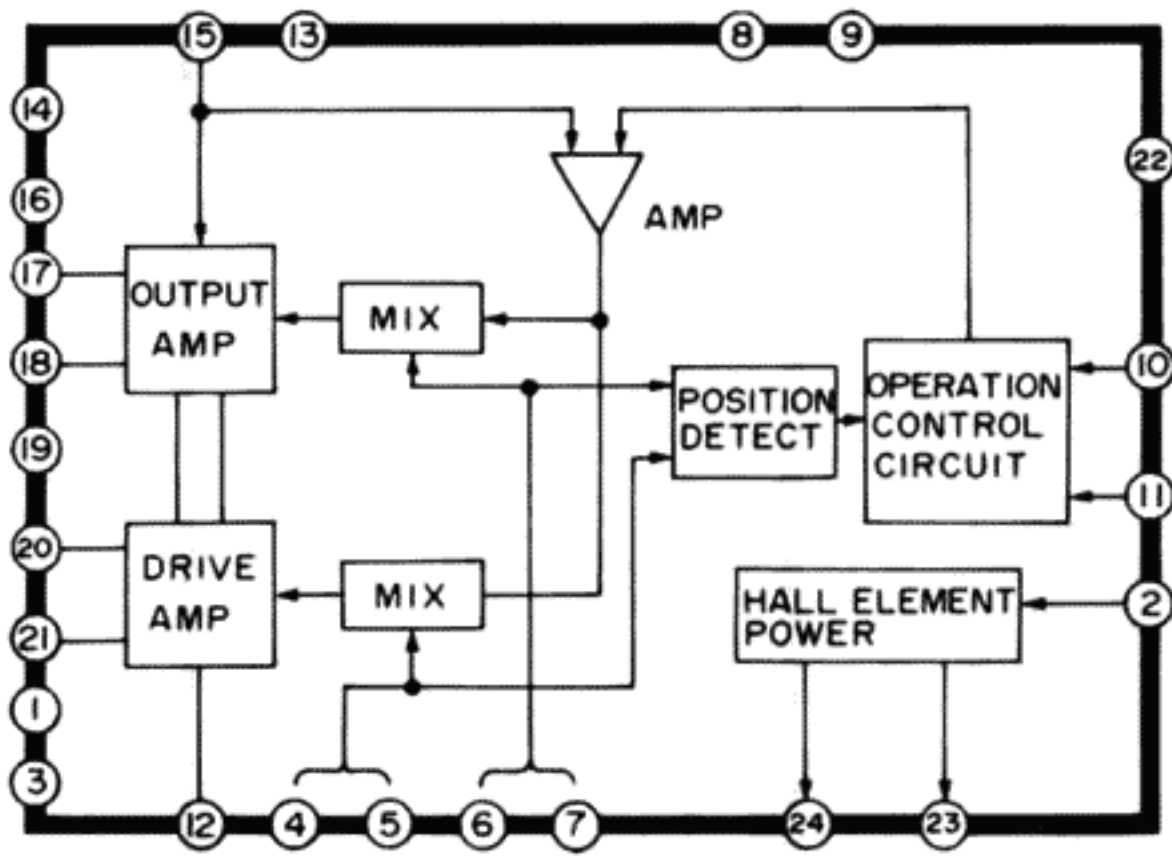

IC101 (AN6635)

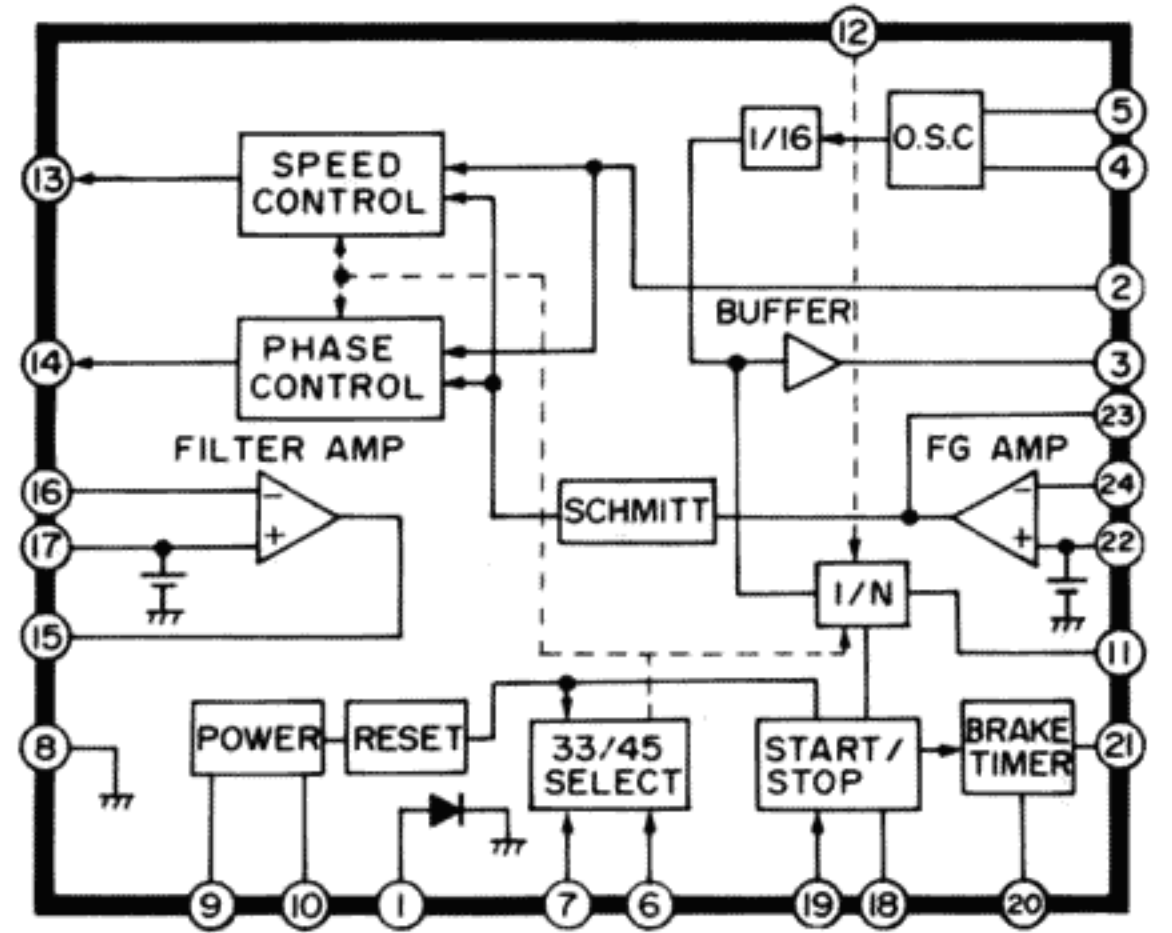

IC201 (AN6680)

CHANGES

Notes:

1. This change of parts list includes the parts changed from those mentioned in SL-7/K Service Manual (ORDER NO. SD8009-1787).
2. The new parts list (page 19, 20 and 29, 30) is mentioned in this Service Manual. Please use this new parts list when placing an order for parts of No. SL-7.
3. SL-7/K Service Manual (ORDER NO. SD8009-1787) must be disused.

■ REPLACEMENT PARTS LIST

Ref. No.	Change of Part No.		Parts Name & Description	Per Set (Pcs.)	Remarks
	OLD SL-7/K (ORDER NO. SD8009-1787)	NEW SL-7 (Revise)			

DIODES

D401	SVDBR3432S	SVDEBR3432S	Light Emitting Diode	1	○
------	------------	-------------	----------------------	---	---

HALL ELEMENT

H1, 2	H-3000A	H-300A	Hall Element	2	○
-------	---------	--------	--------------	---	---

SWITCHES

S1-1	△	SFDSSS5GL	SFDSSS5GLS	Switch, Power	1	○
S1-2	△	SFDSTW9901	SFDSTWM9901	Switch, Power	1	○
S306, 307		SFDSAHA251461	SFDSAHA252461	Switch, End & Rest Detect	2	○

RESISTOR

R211	ERD25TJ683	ERD25TJ563	Carbon, 5.6kΩ, 1/4W, ± 5%	1	
------	------------	-------------------	---------------------------	---	--

CAPACITORS

C6	ECKF1E104ZV	ECQM1H104KZ	Polyester, 0.1μF, 50V, ± 10%	1	
C303	ECKF1E104ZV	ECQM1H104KZ	Polyester, 0.1μF, 50V, ± 10%	1	

Ref. No.	Change of Part No.		Parts Name & Description	Per Set (Pcs.)	Remarks
	OLD SL-7/K (ORDER NO. SD8009-1787)	NEW SL-7 (Revise)			

CABINET and CHASSIS PARTS

10	SFKTC07-04	}	SFUMC07-17R	Guide Ass'y, Power Switch (Refer No. ⑪)	1	○
11	SFUMC07-17					
14	SFUMC07-12					
26	SFKTC07-03					
27	SFKTC07-01	}	SFUMC07-14A	Guide Ass'y, Operation (Refer No. ⑳)	1	○
28	SFKTC07-02					
29	SFUMC07-14					
30	SFUMC07-11					
31	SFUMC07-09					
32	SFUMC07-10	}	SFMZC07-01Z	Stator Frame Ass'y	1	○
41	SFMZC07-01E					
64	SFADC07-01					
10	Addition		SFNZC07-04	Lable, Open	1	○

TONARM PART

112	Addition	SFPZB00702	Bracket	1	○
-----	----------	------------	---------	---	---

SCREWS

①	XSN12	XNS12	Nut	1	WDD
⑭	XTN3+10BFZ	Deletion		0	
⑮	XTB3+8BFN	XTB3+6BFN	Screw	4	WDD
⑳	XXE3D6FZS	XXE3D6FZ	Screw	1	

EXPLODED VIEWS

•Old

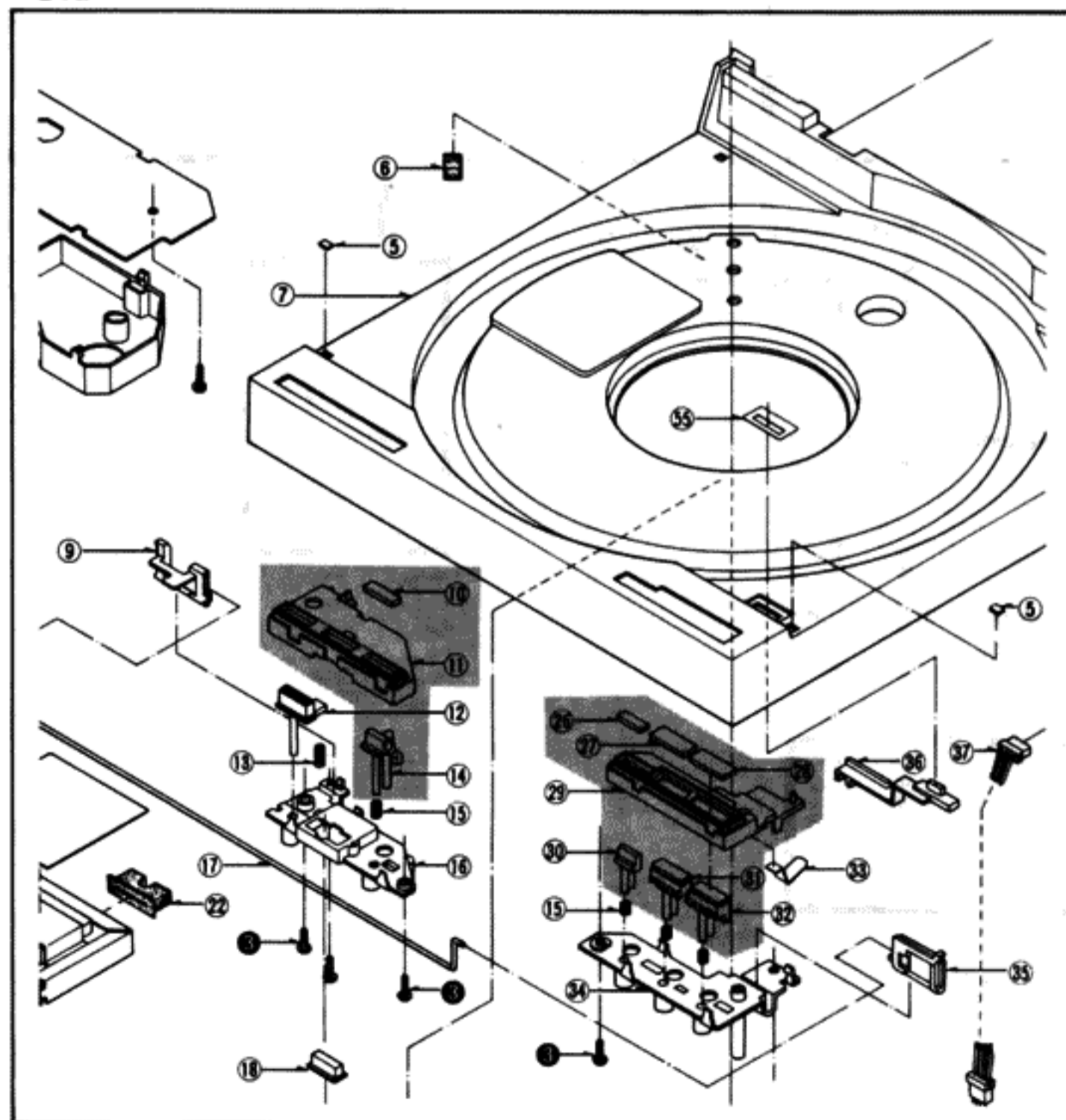

•New

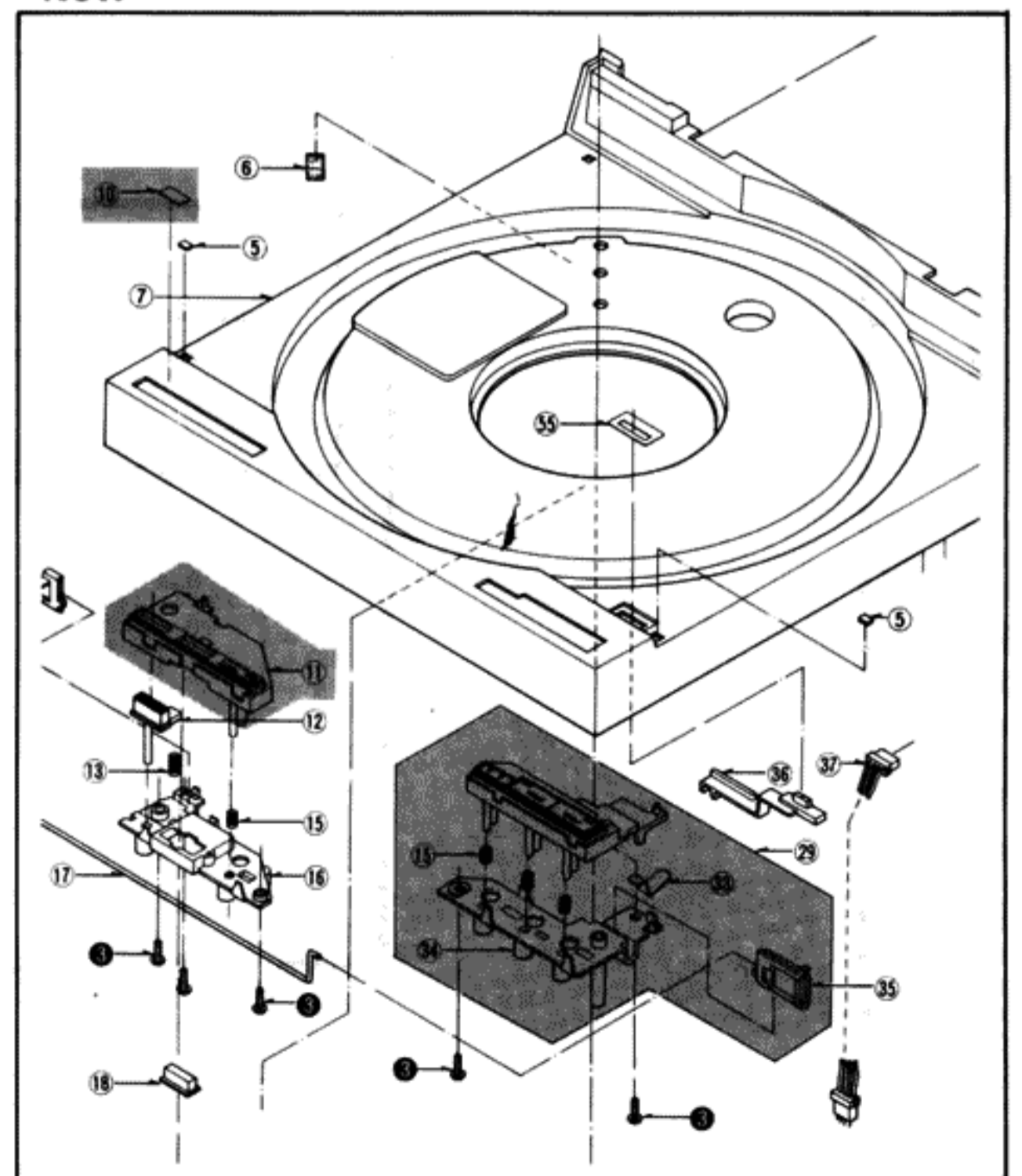

The part of shading areas are changed parts.

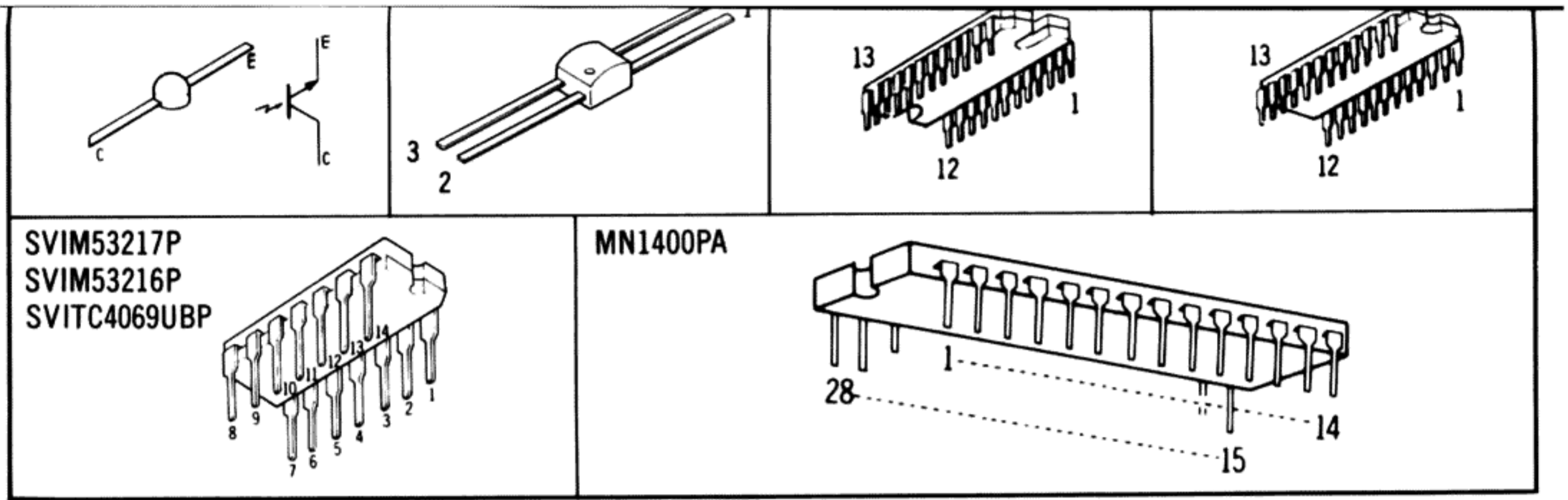

SVIM53217P
SVIM53216P
SVITC4069UBP

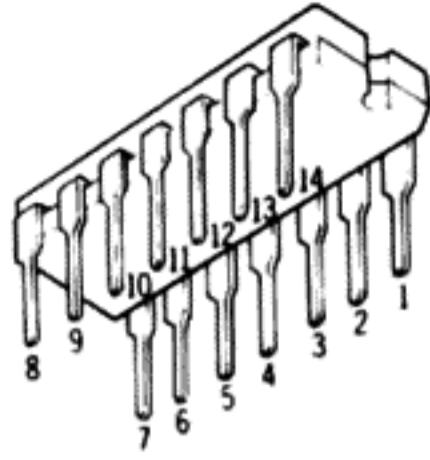

MN1400PA

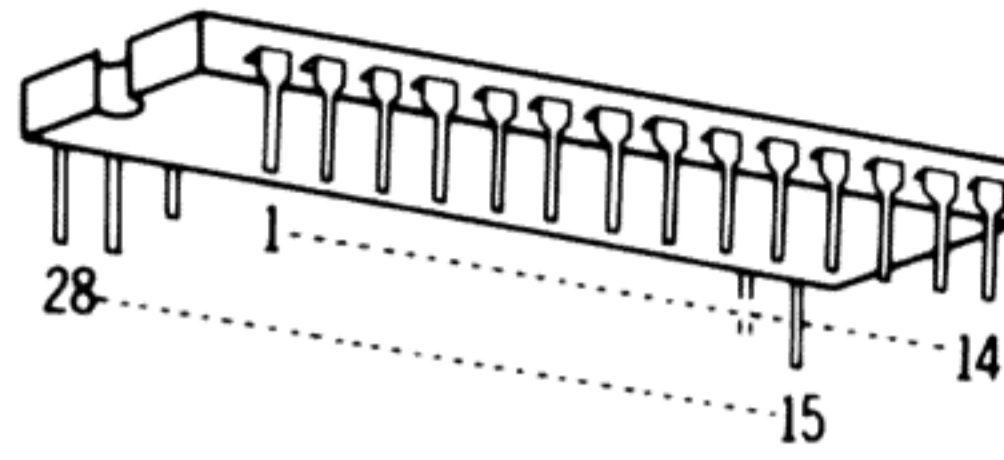

■ REFERENCE VOLTAGE AND WAVEFORM AT EACH IC TERMINAL (PIN)

This indicated voltage values and waveform are measured by oscilloscope at 33rpm rotation.



IC101 (AN6635)

	Stop	Start		Stop	Start		Stop	Start
①	11.2 V	11.2 V	⑨	0 V	1.0 V	⑰	0.6 V	
②	9.3 V	9.3 V	⑩	7.8 V	5.0 V			
③	11.2 V	11.2 V	⑪	5.0 V	5.0 V			
④	2.0 V	2.1 V	⑫	0 V	0 V			
⑤	2.0 V	2.1 V	⑬	11.8 V	11.8 V	⑲	0 V	0 V
⑥	2.0 V	2.1 V	⑭	11.2 V	11.2 V	⑳	0 V	0 V
⑦	2.1 V	2.1 V	⑮	11.8 V	11.7 V	㉑	3.2 V	3.2 V
⑧	0 V	0 V	⑯	11.2 V	11.1 V	㉒	2.5 V	2.5 V

IC201 (AN6680)

	Stop	Start		Stop	Start		Stop	Start
①	2.4 V	2.4 V	⑩	9.3 V	9.3 V	⑰	5.0 V	5.0 V
②		Same as at left	⑪		Same as at left	⑱	0 V	0 V
③			⑫	0 V		0 V	⑳	0.1 V
④		Same as at left	⑬	0.15 V		㉑	5.0 V	0.2 V
⑤			⑭			㉒	0.1 V	
⑥	3.3 V	3.3 V	⑮			㉓	3.1 V	2.9 V
⑦	0 V	0 V	⑯	8.0 V		㉔	3.1 V	
⑧	0 V	0 V				㉒	2.7 V	2.9 V
⑨	10.0 V	10.0 V	⑰	1.9 V	5.0 V			

NOTES:

1. **S1-1, S1-2:** Power switch in "on" position.
2. **S2:** AC – DC select switch in "AC" position.
3. **S3:** Power select switch in "220 – 240V" position.
4. **S201:** Speed select switch in "auto" position.
5. **S301-1, 301-2:** Start switch in "off" position. (not push condition).
 ※◀◀ . . . Moves inward (S301-1) ◀◀ . . . Moves faster (S301-2)
6. **S302-1, 302-2:** Stop switch in "off" position. (not push condition).
 ※▶▶ . . . Moves outward (S302-1) ▶▶ . . . Moves faster (S302-2)
7. **S303:** Cueing switch in "off" position (not push condition).
8. **S304:** Repeat switch in "off" position. (not push condition).
9. **S305:** Cover switch in "off" position.
10. **S306:** Start position switch in "off" position.
11. **S307:** Return position switch in "off" position.
12.  Indicated voltage values are the standard values for the unit measur by the DC electronic circuit tester (high impedance) with the chassis take as standard. Therefore, there may exist some errors in the voltage values depending on th einternal impedance of the DC circuit tester.
13.  indicates that only parts specified by the manufacture be used for safety.
14.  voltage line.

■ TERMINAL GUIDE OF TRANSISTORS AND IC'S

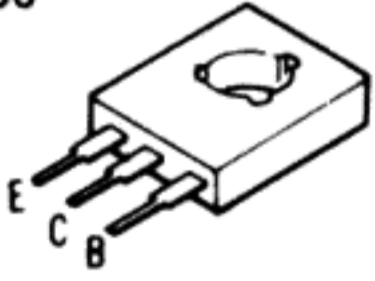
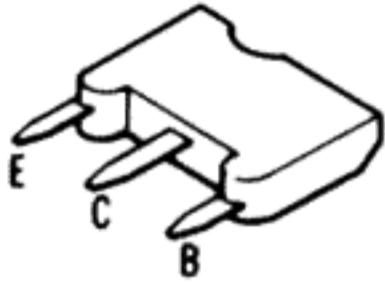
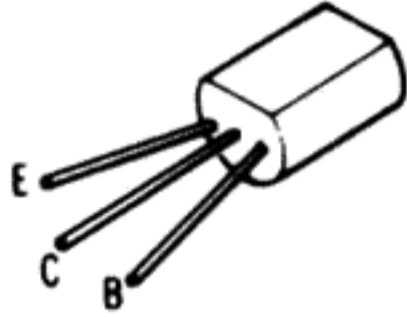
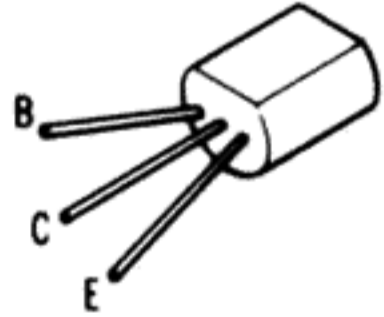
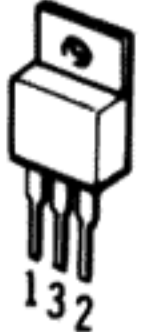
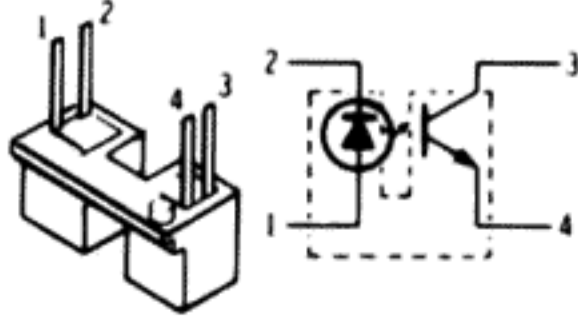
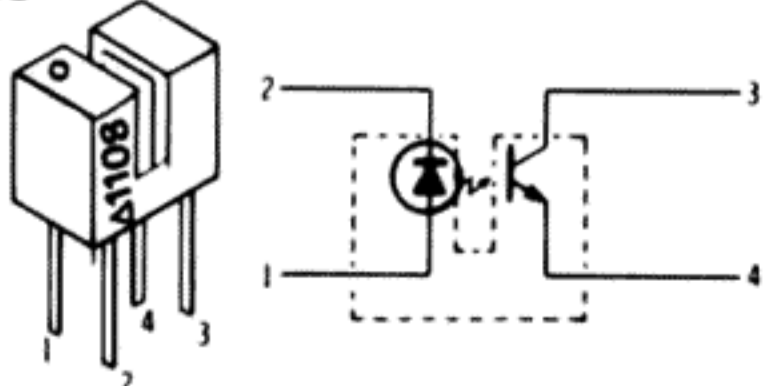
<p>2SC1846 2SC886</p> 	<p>2SB643, 2SB641 2SB636, 2SD638</p> 	<p>2SC1328</p> 	<p>2SC2385</p> 
<p>SVIUPC7812H SVIUPC78M05H</p> 	<p>ON1161</p> 	<p>ON1108</p> 	
<p>SVTPH101</p>	<p>H-300A</p>	<p>AN6635</p>	<p>AN6680</p>