

Service Manual

Direct Drive Automatic Turntable System SL-5

[E], [EK], [XL], [EG], [EB],
[EF], [XA], [EH], [Ei], [EC]

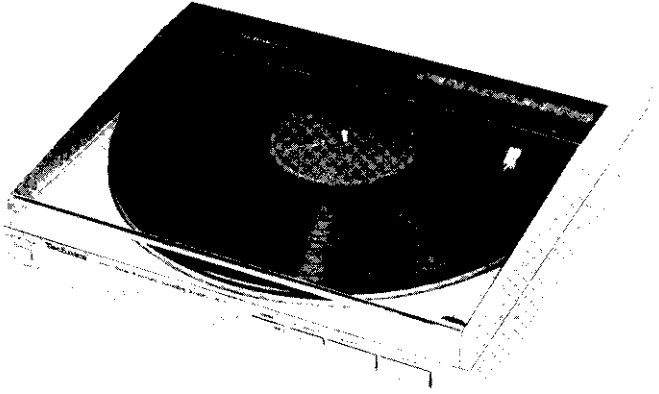

Areas

- * [E] is available in Switzerland and Scandinavia.
- * [EK] is available in United Kingdom.
- * [XL] is available in Australia.
- * [EG] is available in F.R. Germany.
- * [EB] is available in Belgium.
- * [EF] is available in France.
- * [XA] is available in Southeast Asia, Oceania, Africa, Middle Near East and Central South America.
- * [EH] is available in Holland.
- * [Ei] is available in Italy.
- * [EC] is available in Czechoslovakia.

English

Specifications

Specifications are subject to change without notice for further improvement.
Weight and dimensions shown are approximate.

■ General

Power supply: 220V, 50/60 Hz
Power consumption: 10 W
Dimensions: 31.5 × 8.8 × 31.5 cm
 (12-1/2" × 3-1/2" × 12-1/2")
 (W×H×D) 31.5 × 39 × 31.5 cm
 (12-1/2" × 15-23/64" × 12-1/2")
 (Maximum height when top
 (dust cover) is open.)
Weight: 4.4 kg (9.7 lb.)

■ Turntable section

Type: Direct drive
 Automatic turntable
 Auto start/Auto lead-in
 Auto return
 Auto stop
 Repeat play
 Auto speed select
 Manual speed selection possible
 Auto size select
 Record presence detection
Drive method: Direct drive
Motor: Brushless DC motor
Drive control method: F-G servo control
Turntable platter: Aluminum die-cast
 Diameter 30 cm (12")

Turntable speeds: 33-1/3 rpm and 45 rpm
 Auto speed select
 (Manual selection possible)
Wow and flutter: 0.012% WRMS*
 0.025% WRMS (JIS C5521)
 ±0.035% peak
 (IEC 98A Weighted)

Measured by obtaining signal from built-in frequency generator of motor assembly.

Rumble: -56 dB (IEC 98A Unweighted)
 -78 dB (IEC 98A Weighted)

■ Tonearm section

Type: Dynamic balanced type
 Linear tracking tonearm
 4-pivot gimbal suspension
Effective length: 10.5 cm (4-1/8")
Tracking error angle: Within ±0.1°
Effective mass: 9 g (including cartridge)
Resonance frequency: 12 Hz
Tonearm drive motor: DC motor
Phono cable capacitance: 150 pF

■ Cartridge section

Type: Moving magnet stereo cartridge
Magnetic circuit: All laminated core

Technics

Matsushita Electric Trading Co., Ltd.
 P.O. Box 288, Central Osaka Japan

Frequency response:	10 Hz ~ 30 kHz 20 Hz ~ 10 kHz ± 1 dB	Compliance (dynamic):	12×10^{-6} cm/dyne at 100 Hz
Output voltage:	2.5 mV at 1 kHz, 5 cm/s. zero to peak lateral velocity (7 mV at 1 kHz, 10 cm/s. zero to peak 45° velocity [DIN 45 500])	Stylus pressure range:	1.25 ± 0.25 g (12.5 ± 2.5 mN)
Channel separation:	22 dB at 1 kHz	Weight:	6.0 g (cartridge only)
Channel balance:	Within 2 dB at 1 kHz	Replacement stylus:	EPS-24CS
Recommended load impedance:	47 k Ω ~100 k Ω	* The product for destination [XA] is equipped with voltage selector.	
		* Power Supply: 240V, 50/60Hz For United Kingdom and Australia ([EK] and [XL] areas)	

Deutsch

TECHNISCHE DATEN

Änderungen der technischen Daten vorbehalten.
Die angegebenen Gewichts- und Abmessungsdaten sind circa Werte.

■ Allgemeine Daten

Stromversorgung:	220 V, 50/60 Hz Wechselstrom
Leistungsaufnahme:	10 W
Abmessungen: (B×H×T)	31,5×8,8×31,5 cm 31,5×39×31,5 cm (Maximale Höhe bei vollständig geöffnetem Gehäuseoberteil.)
Gewicht:	4,4 kg

■ Plattenspieler

Typ:	Direktantriebener Automatischer Plattenspieler Auto-Start/Auto-Zuführung Rückführautomatik Stop-Automatik Wiederhol-Betrieb Automatische Drehzahlwahl Manuelle Drehzahlwahl möglich Automatische Plattengrößewahl Plattenpräsenz-Registrierung Direktantrieb
Antrieb:	Kollektorloser Gleichstrommotor
Motor:	FG-Servo-Steuerung
Antriebsregel-Methode:	Aluminium-Druckguß
Plattenteller:	Durchmesser 30 cm
Plattenteller-Drehzahlen:	33-1/3 und 45 U/min Automatische Drehzahlwahl (manuelle Wahl möglich)
Gleichlaufschwankungen:	0,012% WRMS* 0,025% WRMS (JIS C5521) $\pm 0,035\%$ Spitze (IEC 98A bewertet)

*Gemessen anhand von Signalen vom eingebauten Frequenzgenerator des Motorbauteils.

Rumpel-Fremdspannungsabstand:	-56 dB (IEC 98A unbewertet)
Rumpel-Geräuschspannungsabstand:	-78 dB (IEC 98A bewertet)

■ Tonarm

Typ:	Dynamisch ausbalancierter Tangential-Tonarm mit Kardanaufhängung mit 4-Punkt-Drehlager
Effektive Länge:	105 mm
Spurfehlwinkel:	Innerhalb $\pm 0,1^\circ$
Effektive Masse:	9 g (einschließlich Tonabnehmer)
Resonanzfrequenz:	12 Hz
Tonarm-Antriebsmotor:	Gleichstrommotor

■ Tonabnehmer

Typ:	Stereo-Magnet-Tonabnehmer mit Einpunkt-Aufhängungssystem
Magnetkreis:	Ganzlamellenkern
Frequenzgang:	10 Hz bis 30 kHz 20 Hz bis 10 kHz ± 1 dB
Ausgangsspannung:	2,5 mV bei 1 kHz 5 cm/s. Null-zu-Spitze, lateral [7 mV bei 1 kHz 10 cm/s. Null-zu-Spitze, 45° (DIN 45 500)] 22 dB bei 1 kHz Innerhalb 2 dB bei 1 kHz
Kanaltrennung:	
Kanalabweichung:	
Empfohlene Endimpedanz:	47 k Ω ~ 100 k Ω
Nachgiebigkeit (dynamisch):	12×10^{-6} cm/dyn bei 100 Hz
Auflagekraft-Einstellbereich:	$1,25 \pm 0,25$ g ($12,5 \pm 2,5$ mN)
Gewicht:	6,0 g (nur Tonabnehmer)
Ersatznadel:	EPS-24CS

CARACTERISTIQUES

Les spécifications sont susceptibles d'être modifiées sans préavis.
Le poids et les dimensions donnés sont approximatifs.

■ Généralités

Alimentation:	Alternatif 220 V, 50/60 Hz
Consommation:	10 W
Dimensions: (L×H×P)	31,5 × 8,8 × 31,5 cm 31,5 × 39 × 31,5 cm (Hauteur maximum lorsque le dessus (couvercle protège-poussière) est ouvert.)
Poids:	4,4 kg

■ Platine de lecture

Type:	Entraînement direct Platine automatique Départ automatique/Entrée automatique Retour automatique Arrêt automatique Audition répétée Sélection de vitesse automatique Sélection automatique du diamètre Sélection de vitesse manuelle possible Détection de la présence d'un disque
--------------	---

Système d'entraînement:

Entraînement direct

Moteur:

Moteur C.C. sans balai

Système de commande d'entraînement:

Générateur de fréquences à servo-commande

Plateau de lecture:

Aluminium moulé sous pression
Diamètre 30 cm

Vitesses de la platine:

33-1/3 et 45 t/p.m.
Sélecteur de vitesse automatique
(Sélection manuelle possible)

Pleurage et scintillement:

0,012% de valeur efficace*
0,025% de valeur efficace
(JIS C5521)
±0,035% de crête
(IEC 98A Pondéré)

* Mesuré par l'obtention d'un signal provenant du générateur de fréquences incorporé de l'ensemble du moteur.

Ronflement: -56 dB (IEC 98A Non pondéré)
-78 dB (IEC 98A Pondéré)

■ Bras de lecture

Type:	Bras de lecture d'alignement linéaire de type à équilibre dynamique avec suspension à la cardan à 4 pivots
Longueur effective:	105 mm
Angle d'erreur de piste:	En deçà de ±0,1°
Masse réelle:	9 g (y compris la cellule pick-up)
Fréquence de résonance:	12 Hz
Moteur d'entraînement du bras de lecture:	Moteur C.C.

■ Cellule pick-up

Type:	Cellule pick-up stéréo à aimant mobile
Circuit magnétique:	Noyau entièrement feuilleté
Réponse en fréquence:	10 Hz à 30 kHz 20 Hz à 10 kHz ±1 dB
Tension de sortie:	2,5 mV à 1 kHz; 5 cm/s. zéro à vitesse latérale de crête (7 mV à 1 kHz; 10 cm/s., zéro à vitesse 45° de crête [DIN 45 000])
Séparation des canaux:	22 dB à 1 kHz
Équilibrage des canaux:	En deçà de 2 dB à 1 kHz
Impédance de charge recommandée:	47 kΩ~100 kΩ
Elasticité (dynamique):	12 × 10 ⁻⁶ cm/dyne à 100 Hz
Plage de la force verticale d'appui:	1,25 ±0,25 g (12,5 ±2,5 mN)
Poids:	6,0 g (cellule seule)
Remplacement de la pointe de lecture:	EPS-24CS

ESPECIFICACIONES

Las especificaciones quedan sujetas a cambios sin aviso previo.
Los peso y las dimensiones indicados son aproximados.

■ En general

Alimentación de corriente:	220 V, 50/60 Hz
Consumo de corriente:	10 W
Dimensiones: (Ancho×Alto×Prof.)	31,5×8,8×31,5 cm 31,5×39×31,5 cm (Altura máxima cuando la parte de arriba (tape contra el polvo) está abierta.)
Peso:	4,4 kg

■ Sección del plato giratorio

Tipo:	Accionamiento directo Plato giratorio automático Arranque automático/ Comienzo automático Retorno automático Parada automática Ejecución repetida Selección automática de la velocidad
--------------	---

Es posible seleccionar la velocidad a mano
Selección automática del tamaño
Detección de presencia de disco

Método de accionamiento:

Accionamiento directo

Motor:

Motor de corriente continua sin escobillas

Método de control de accionamiento:

Servocontrol por generador de frecuencias

Platillo del plato giratorio:

Aluminio fundido
30 cm de diámetro

Velocidades del plato giratorio:

33-1/3 y 45 rpm
Selección automática de la velocidad
(También posibilidad de seleccionar a mano)

Ululaciones y trémolo: 0,012% WRMS*
0,025% WRMS (JIS C5521)
±0,035% cresta
(IEC 98A Ponderado)

*Medido obteniendo una señal proveniente del generador de frecuencias incorporado del conjunto del motor.

Ruido de rodadura: -56 dB (IEC 98A No ponderado)
-78 dB (IEC 98A Ponderado)

■ Sección del brazo sonoro

Tipo: Brazo sonoro de seguimiento lineal de tipo con equilibrio dinámico con suspensión cardánica de 4 pivotes

Longitud efectiva: 10,5 cm

Angulo de error de seguimiento: Inferior a ±0,1° aproxim.

Masa efectiva: 9 g (incluyendo el cartucho)

Frecuencia de resonancia: 12 Hz

Motor de accionamiento del brazo sonoro: Motor de corriente continua

■ Sección del cartucho

Tipo: Cartucho estereofónico de imán móvil

Circuito magnético: Núcleo totalmente laminado

Respuesta de frecuencia: 10 Hz a 30 kHz
20 Hz a 10 kHz ±1 dB

Voltaje de salida: 2,5 mV a 1 kHz
Velocidad lateral de cero a cresta de 5 cm/s
(7 mV a 1 kHz. Velocidad de 45° de cero a cresta de 10 cm/s [DIN 45 500])

Separación de canales: 22 dB a 1 kHz

Equilibrio de canales de la aguja: Inferior a 2 dB a 1 kHz

Impedancia de carga recomendada: 47 kΩ~100 kΩ

Elasticidad (dinámica): 12×10^{-6} cm/dina a 100 Hz

Radio de presión de la aguja: 1,25 ±0,25 g (12,5 ±2,5 mN)

Peso: 6,0 g (cartucho solamente)

Aguja de recambio: EPS-24CS

■ CONTENTS

	Page
LOCATION OF CONTROLS	4, 5
DISASSEMBLY INSTRUCTIONS	6 ~ 8
HOW TO SET THE TONEARM DRIVE ROPE	9
CHECKING METHOD OF THE UNIT	9
MEASUREMENTS AND ADJUSTMENTS (English)	10 ~ 12
MESSUNGEN UND JUSTIERUNGEN (Deutsch)	13, 14
MESURAGES ET REGLAGES (Français)	15, 16
MEDICIONES Y AJUSTE (Español)	17, 18
REPLACEMENT PARTS (Electric Parts)	19

	Page
TIMING CHART	20
BLOCK DIAGRAM	21, 22
CIRCUIT BOARD AND WIRING CONNECTION DIAGRAM	23, 24
SCHEMATIC DIAGRAM	25, 26
EXPLODED VIEWS	27, 29
REPLACEMENT PARTS LIST (Cabinet and Chassis Parts)	29
PACKINGS	30

■ LOCATION OF CONTROLS

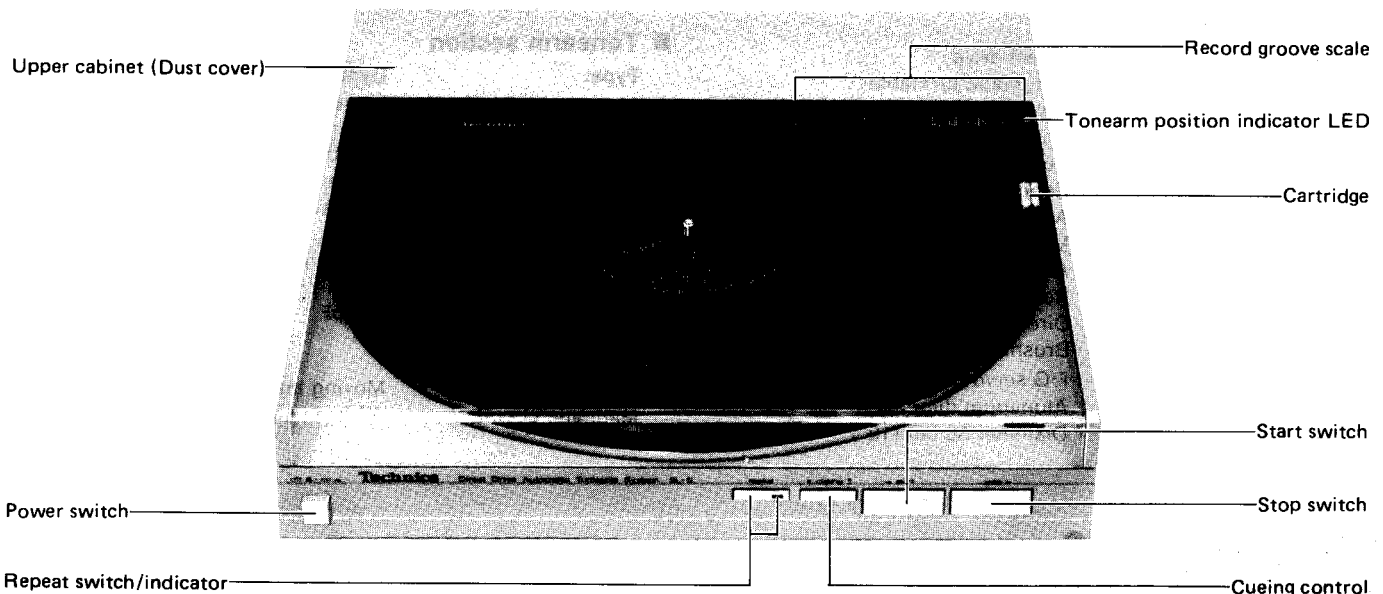

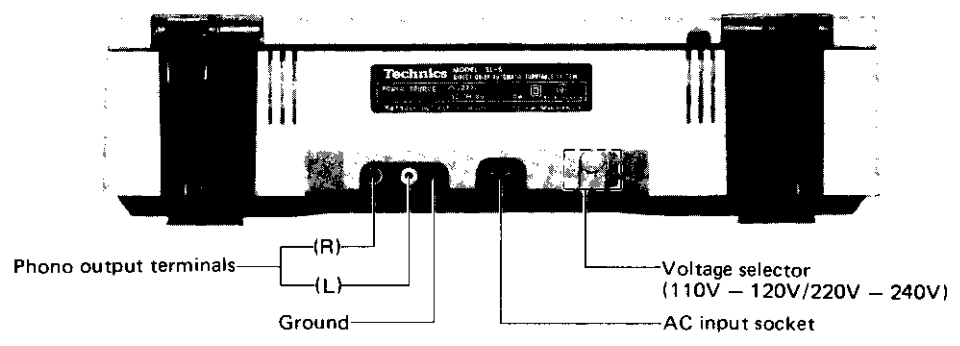

*The product for destination [XA] is equipped with voltage selector.

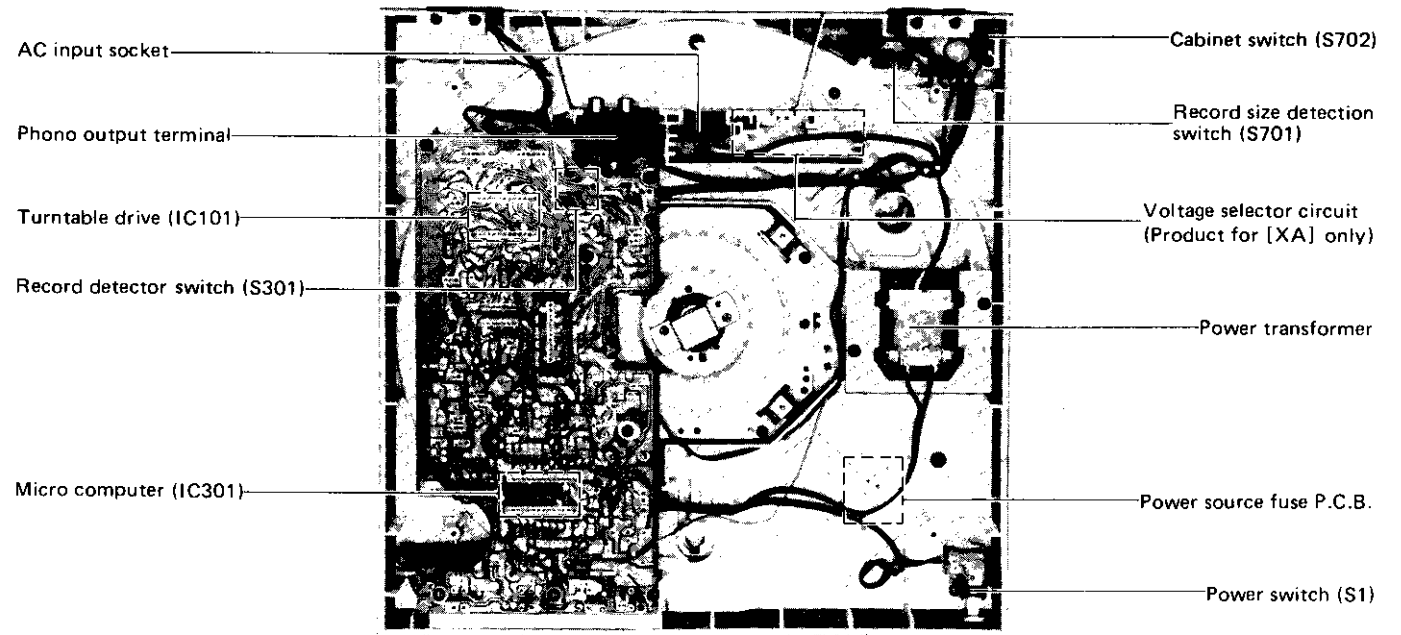
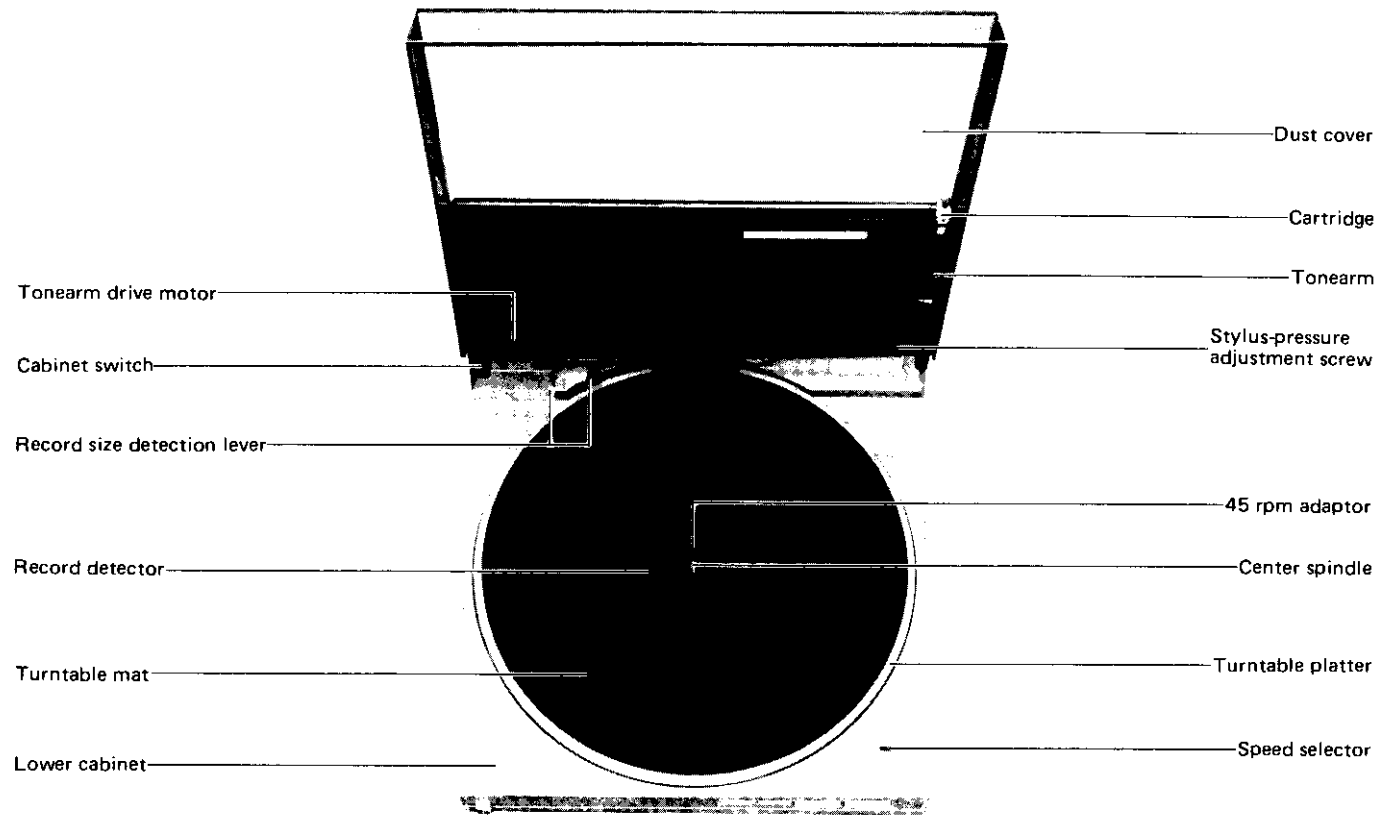

DISASSEMBLY INSTRUCTIONS

How to remove the turntable

1. Open the upper cabinet.
2. Detach the 45 rpm adaptor as shown in Fig. 1.
3. Remove the turntable mat and lift up the turntable.
*The turntable is tight fitted onto the center spindle. When removing the turntable, take care not to give damage to the upper cabinet arm motor cover and tonearm cover.
4. When putting the turntable mat on the turntable, match the projection of the turntable (record detector) with the hold of the turntable mat. (See Fig. 2)

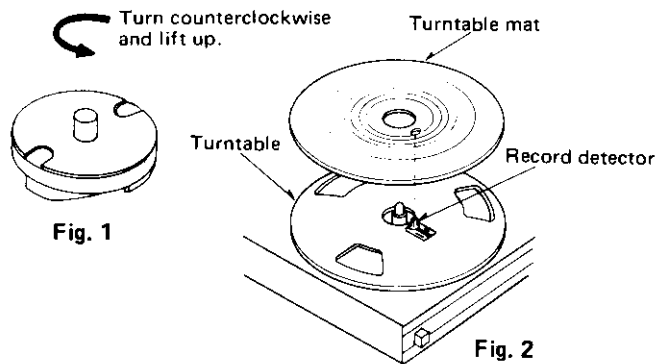

How to remove the main printed circuit board

1. Detach the bottom board. (Refer to "How to remove the bottom board".)
2. Remove the 6 setscrews of the printed circuit board. (Fig. 4 : ⑤ ~ ⑩)
3. When attaching the printed circuit board, turn the record detector lever counterclockwise. Next, insert the speed selector switch into the knob, and then insert the connector onto the stator frame pins. (Fig. 4)

*The printed circuit board is grounded to the chassis by screw ⑧. When checking the conduction without screw ⑧, connect the ground terminal of the printed circuit board to the chassis (stator frame).

How to remove the stator frame

1. Detach the main printed circuit board. (Refer to "How to remove the main printed circuit board".)
2. Remove the 3 setscrews of the stator frame. (Fig. 4 : ⑪ ~ ⑬)

How to remove the dust cover

1. Open the upper cabinet.
2. Remove the 2 setscrews and pin of the arm motor cover. (Fig. 5 : ⑭ ~ ⑯).
3. Press the 2 lugs of the cover with a screwdriver and remove the motor cover. (See Fig. 5)
4. Remove the 5 setscrews of the dust cover. (Fig. 6 : ⑰, ⑱ and Fig. 7 : ⑲ ~ ㉑)

*Photo 1 shows the set with the dust cover removed.

How to remove the bottom board

1. Remove the 45 rpm adaptor and turntable.
2. Turn over the body on a soft cloth taking care not to damage the upper cabinet and dust cover.
3. Remove the 4 setscrews. (Fig. 3 : ① ~ ④)

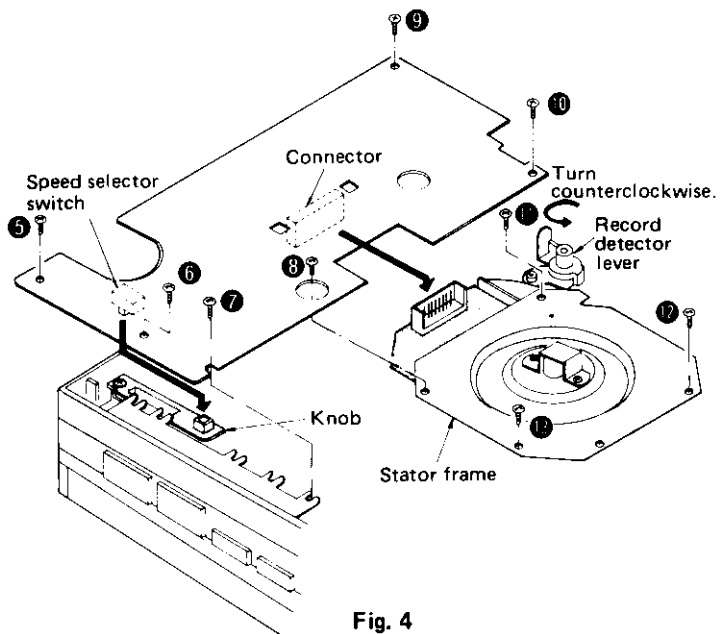
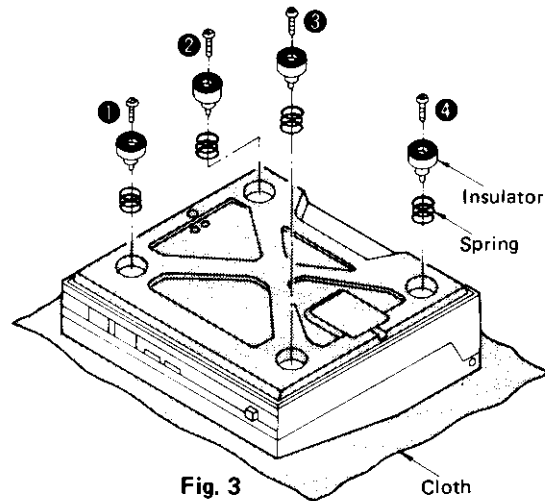

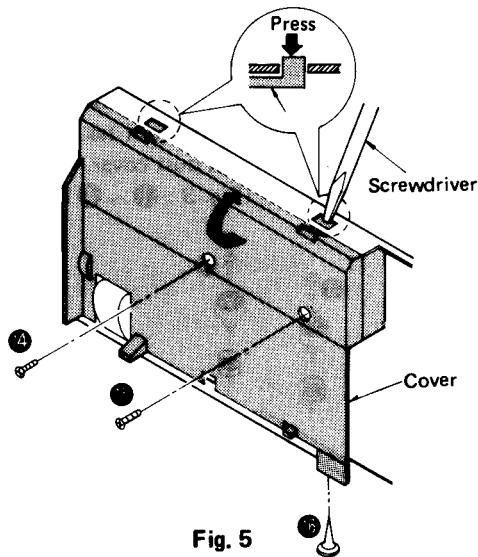

Fig. 5

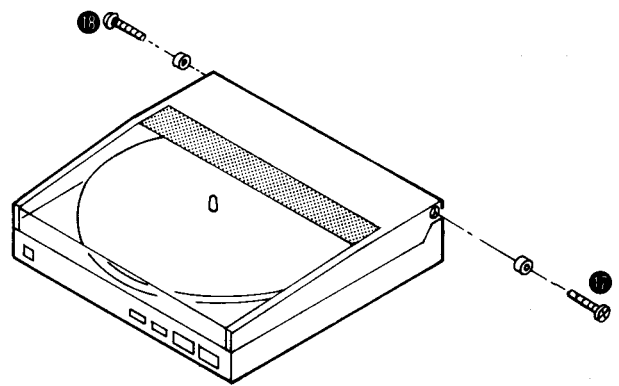
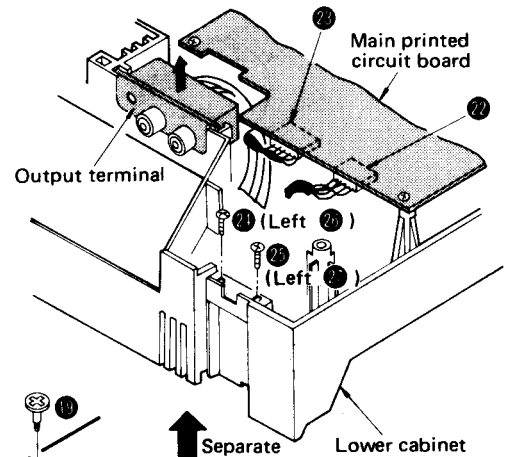

Fig. 6

● **How to remove the upper cabinet**
(Separation of cabinet)

1. Remove the bottom board. (Refer to "How to remove the bottom board".)
2. Detach the output terminal from lower cabinet. (Fig. 7)
3. Pull out connectors 22 and 23. (Fig. 7)
4. Remove the 4 setscrews of the hinge. (Fig. 7 : 24 ~ 27)
5. The hinge is engaged with the lower cabinet. The lower cabinet can be separated from the upper cabinet by lifting the cabinet while releasing the hinge claws. (See Fig. 7 (A))



● **How to remove the arm motor printed board**

1. Open the upper cabinet and detach the arm motor cover. (Refer to "How to remove the dust cover".)
2. Remove the setscrews 28. (Fig. 7)
3. Release the claws with the nail and remove the position detecting circuit and the rest switch. (Fig. 7 : (B), (C))

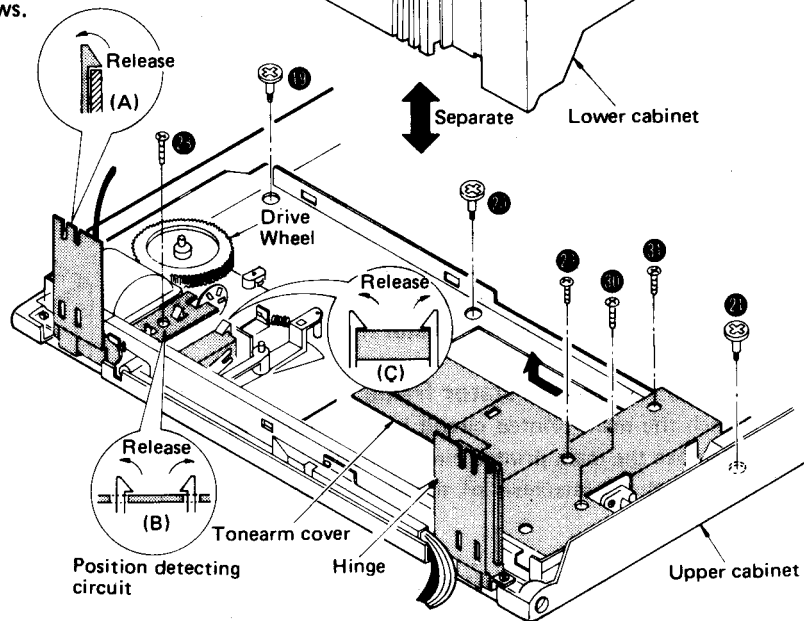

Fig. 7

● **How to remove the Hall element**

1. Remove the turntable. (Refer to "How to remove the turntable".)
2. Unsolder the Hall element.

* The Hall element should be installed with the marking side up as in Fig. 8.

With the marking side up, no problem will occur even when the leg is reversed in position.

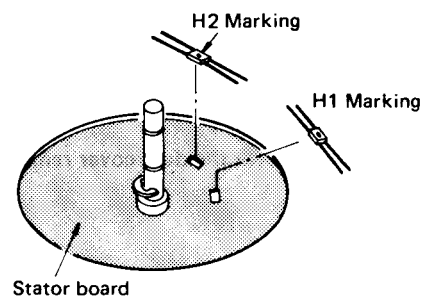

Fig. 8

● **How to remove the cartridge**

1. Open the upper cabinet.
2. Completely loosen the setscrew and pull out the cartridge. (Fig. 9)
3. When attaching the cartridge again, match the tonearm connector with the cartridge pin, then completely insert it and tighten the setscrew.

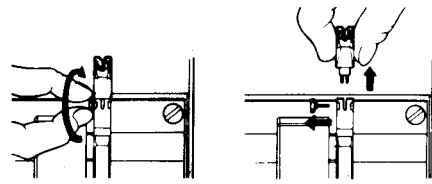

Fig. 9

● **How to remove the tonearm**

1. Remove the cartridge. (Refer to "How to remove the cartridge".)
2. Remove the 3 setscrews of the tonearm cover (Fig. 7 : 29 ~ 31) and detach the cover in the direction of the arrow.
3. Unsolder 5 leads of the cartridge. (Fig. 10)
4. Remove the setscrew of the tonearm board. (Fig. 10 : 32)
5. Remove the setscrew of the tonearm. (Fig. 11 : 33)

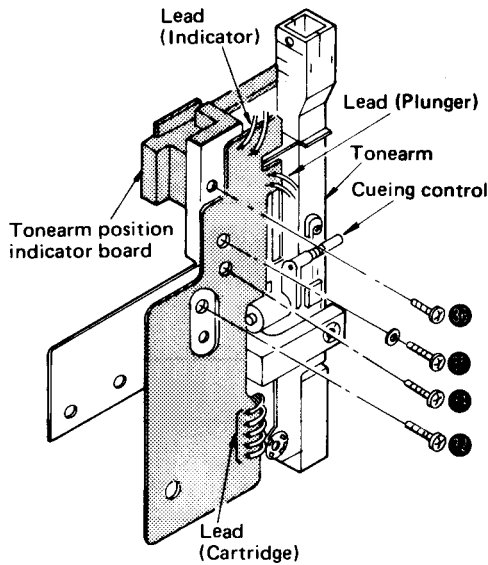

Fig. 10

● **How to remove the cueing control ass'y**

1. Remove the cartridge. (Refer to "How to remove the cartridge".)
2. Remove the tonearm cover. (Refer to "How to remove the tonearm".)
3. Unsolder 2 leads of the plunger.
4. Remove the 2 setscrews of the cueing control ass'y. (Fig. 10 : 34, 35)

● **How to remove the tonearm position indicator board**

1. Remove the cartridge. (Refer to "How to remove the cartridge".)
2. Remove the tonearm cover. (Refer to "How to remove the tonearm".)
3. Unsolder 2 leads of the indicator. (Fig. 10)
4. Remove the setscrew of the tonearm position indicator board. (Fig. 10 : 36)

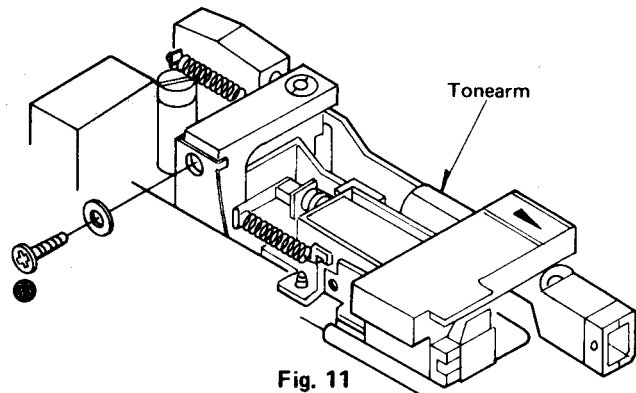

Fig. 11

● **How to remove the cabinet switch**

1. Remove the bottom board. (Refer to "How to remove the bottom board".)
2. Remove the setscrew of the cabinet switch. (Fig. 12 : 37)
3. When fitting the cabinet switch, be sure to open the upper cabinet.

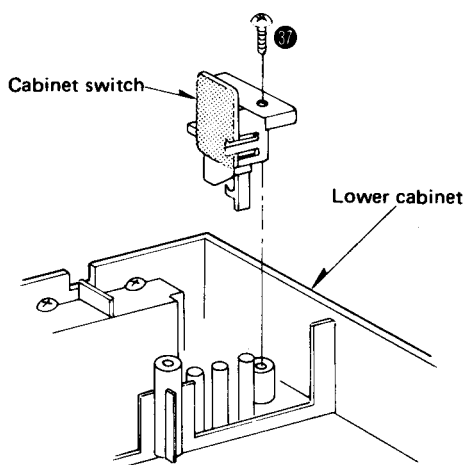

Fig. 12

● **How to remove the on/off switch**

1. Remove the bottom board. (Refer to "How to remove the bottom board".)
2. Pull out the knob.
3. Remove the setscrew of the on/off switch. (Fig. 13 : 38)

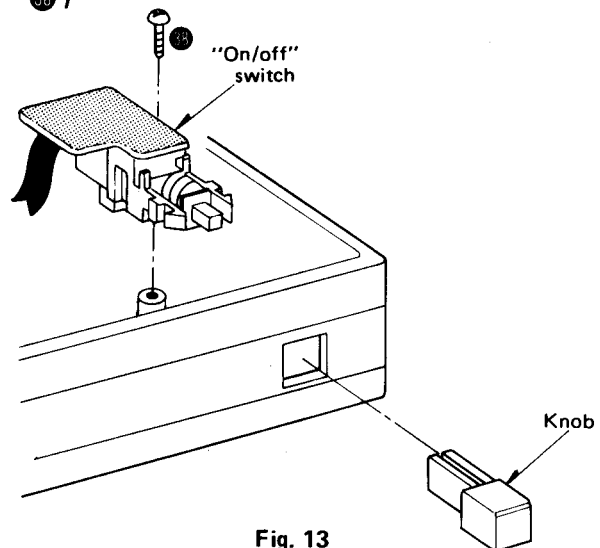

Fig. 13

■ HOW TO SET THE TONEARM DRIVE ROPE

Set the rope according to the following procedure.

1. Open the upper cabinet and remove the cartridge.
2. Remove the arm motor cover and tonearm cover.
3. Detach the arm drive wheel "C" ring ③⑨ and washer ④⑩, and remove the drive wheel. (See Fig. 14)
4. Turn over the arm drive wheel and set the rope in the order of 1 ~ 2. (Fig. 15)
5. Holding the rope set over the arm drive wheel with the hand, set the rope over the wheels in the order of 3 ~ 5 in Fig. 16.
6. After setting the rope, rotate the worm gear by hand until the tonearm matches the rope connector.
7. Rotate the worm gear by hand and check that the tonearm operates, and then fit the washer ④⑩ and "C" ring ③⑨ in place.

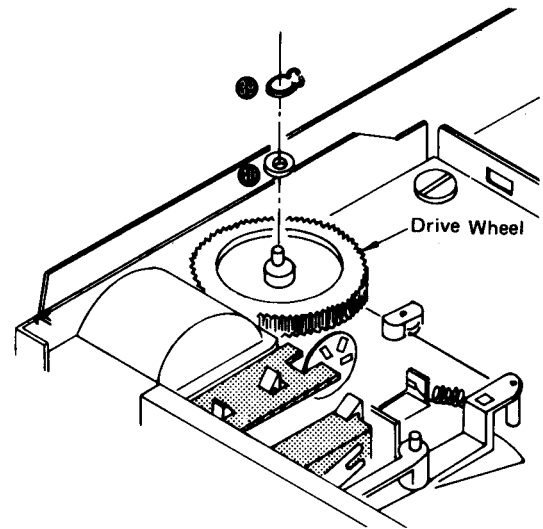

Fig. 14

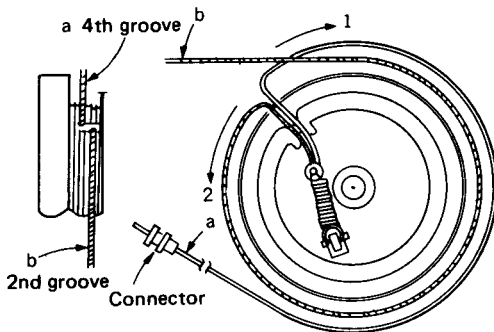

Fig. 15

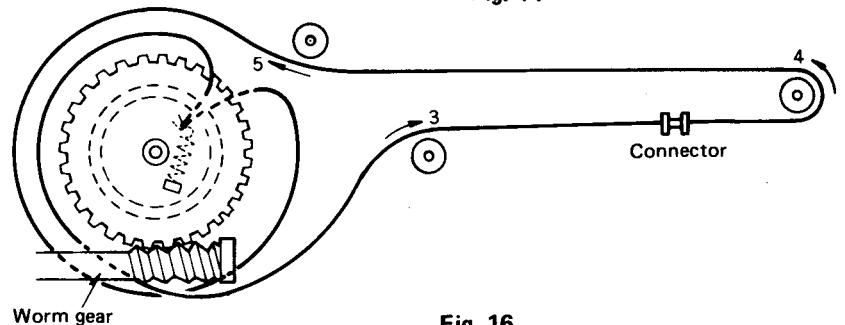
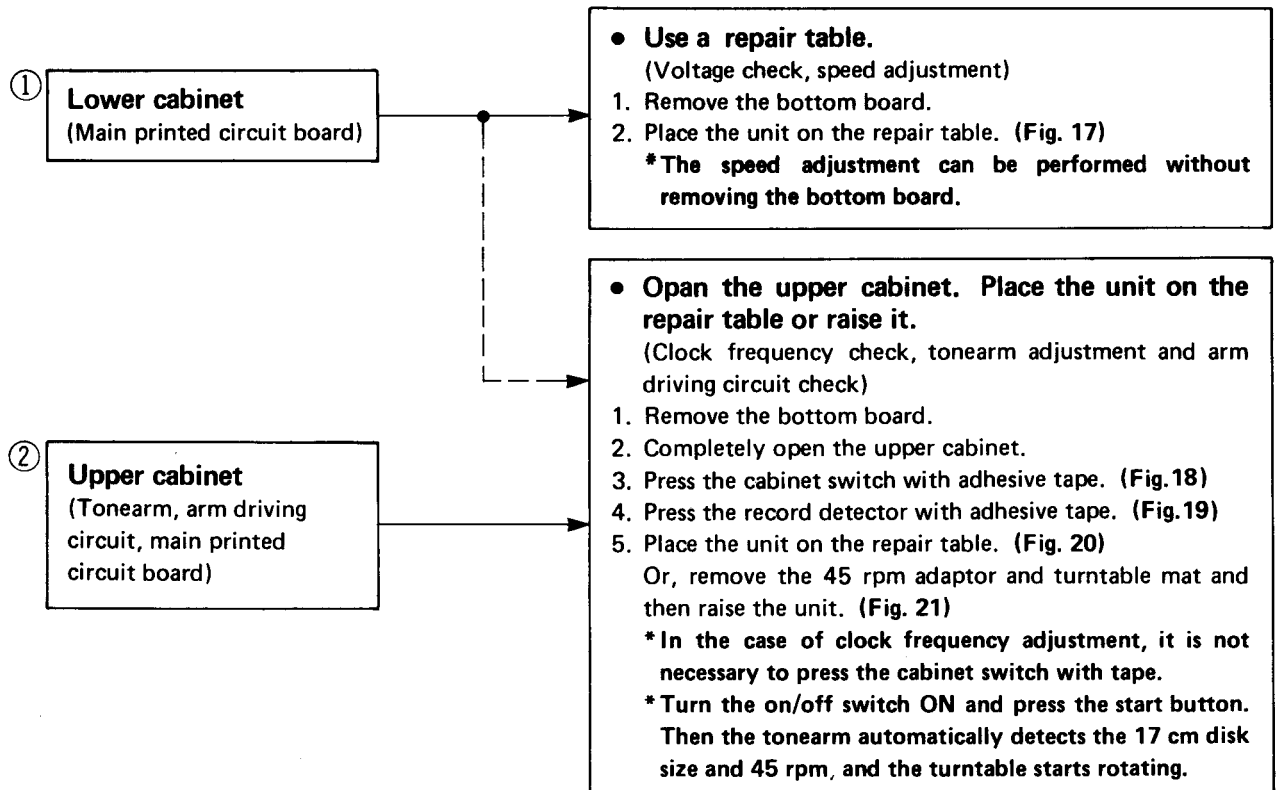

Fig. 16

■ CHECKING METHOD OF THE UNIT

The unit (circuits, etc.) can be checked and adjusted by the following method.



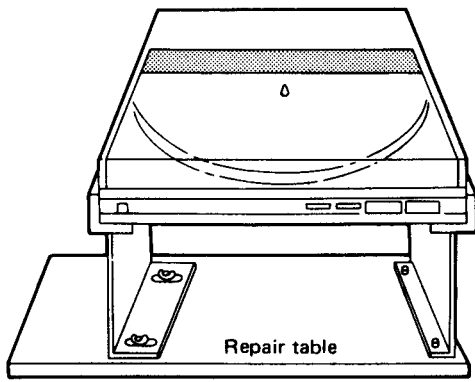

Fig. 17

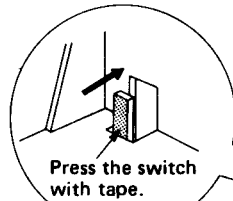

Fig. 18

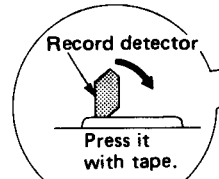

Fig. 19

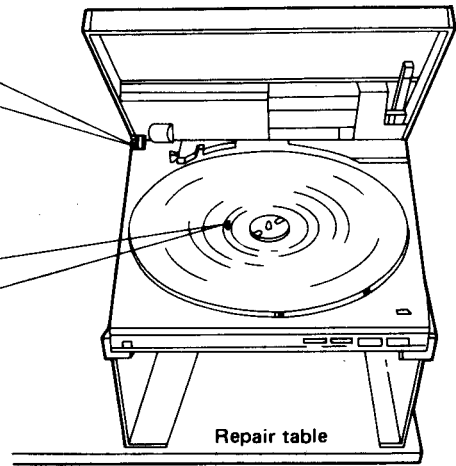

Fig. 20
(Abb. 1)

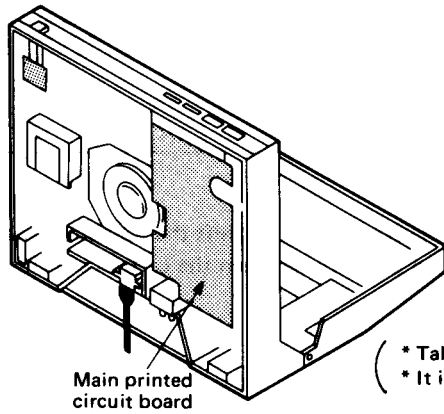
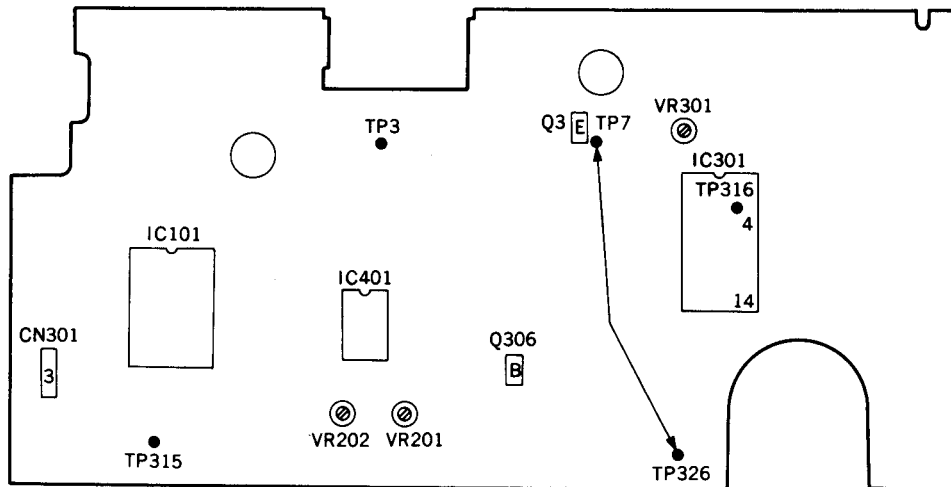

Fig. 21

(* Take care not to allow the unit to fall down.
* It is desirable to use a repair table for the repair job.)

MEASUREMENTS AND ADJUSTMENTS English

- Diagram for printed circuit board adjustment



- * Connect between TP7 and TP326 for clock frequency adjustment.
- * Zwischen TP7 und TP326 anschließen, für die Zeitgeberfrequenz.
- * Connecter entre TP7 et TP326 pour le réglage de la fréquence des impulsions d'horloge.
- * Conectar entre TP7 y TP326 para ajuste de frecuencia de reloj.

● Instruments used

1. DC voltmeter
2. Oscilloscope or frequency counter

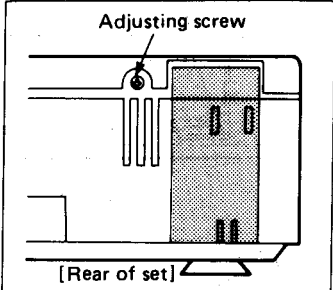
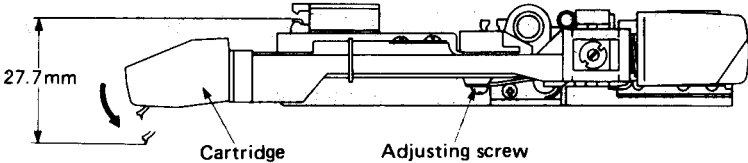
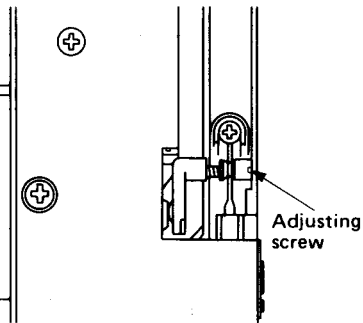
Step	Item	Adjustment procedure
1	Auto start position	<ol style="list-style-type: none"> 1 Make sure that the tonearm is at the start position (on the rest). 2 Adjust by turning the auto start position adjusting screw. <p>Tonearm lowers inside the disc: Turn the adjusting screw clockwise.</p> <p>Tonearm lowers outside the disc: Turn the adjusting screw anticlockwise.</p> <p>*Be sure to use 30 cm record for the adjustment.</p> 
2	Arm lift height	<ol style="list-style-type: none"> 1 Make the set as illustrated in Fig. 20. 2 Set the on/off switch to "on" and press the start switch to shift the tonearm inward. 3 Press the cueing control button so that the distance between the cartridge stylus tip and the guide rail is 27.7 mm. <p>To increase the distance turn the adjusting screw anticlockwise.</p> <p>To decrease the distance turn the adjusting screw clockwise.</p> 
3	Tonearm offset angle	<ol style="list-style-type: none"> 1 Make the set as illustrated in Fig. 20. 2 Set the on/off switch to "on" and press the start switch to shift the tonearm inward. 3 Turn the offset angle adjusting screw so that the arm center matches the V-groove of the lift bar. 

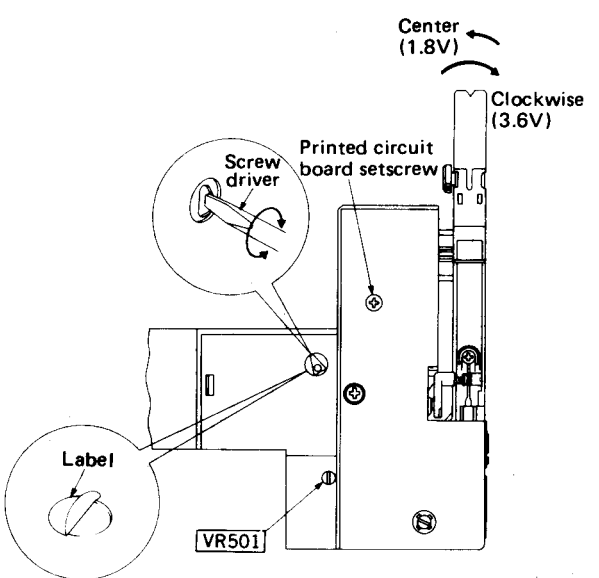
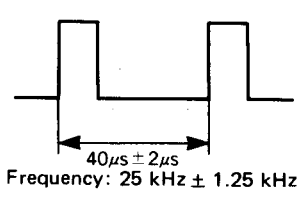
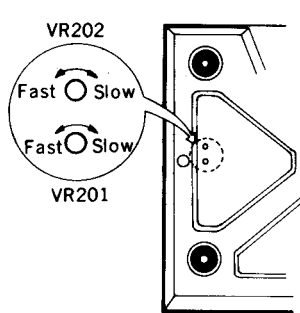
Step	Item	Adjustment procedure
4	Servo gain and offset voltage	<ol style="list-style-type: none"> 1 Make the set as illustrated in Fig. 20. 2 Connect the DC voltmeter to TP315 (Q306) base or connector CN301 terminal ③ and TP3 (earth). 3 Set the on/off switch to "on" and press the start switch to shift the tonearm inward. 4 Remove the label of the tonearm cover. 5 Completely shift the tonearm to the right. Then, adjust VR501 so that the voltage is 3.6V. (Servo gain adjustment) 6 Set the tonearm to the center and make sure that the output voltage is 1.8V. If the voltage is not 1.8V, loosen the printed circuit board setscrew and move the board to the right of left by a screwdriver so that the output voltage becomes 1.8V. After the adjustment, tighten the printed circuit board setscrew. (Offset adjustment) 
5	Clock frequency	<ol style="list-style-type: none"> 1 Make the set as illustrated in Fig. 20. 2 Remove the tape from the cabinet switch. 3 Connect TP7 (Q3 emitter) to TP326 (IC301 pin 14) with clip lead or the like. 4 Connect the oscilloscope or frequency counter to TP316 (IC301 pin 4). 5 Set the on/off switch to "on". 6 Adjust VR301 so that the output waveform cycle is $40 \mu\text{s} \pm 2 \mu\text{s}$. Also, adjust VR301 so that the output frequency is $25 \text{ kHz} \pm 1.25 \text{ kHz}$. 
6	Rotational speed	<ol style="list-style-type: none"> 1 Make the set as illustrated in Fig. 20. 2 Play a 17 cm record. 3 Turn VR202 to adjust the speed to the rated speed (45 rpm). 4 Play a 30 cm record. 5 Turn VR201 to adjust the speed to the rated speed (33-1/3 rpm). <p>Note: Be sure to adjust 45 rpm first.</p> 

■ MESSUNGEN UND JUSTIERUNGEN Deutsch

• Zu verwendende Instrumente

1. Elektronisches Gleichstrom-Voltmeter
2. Oszilloskop oder Frequenzzähler

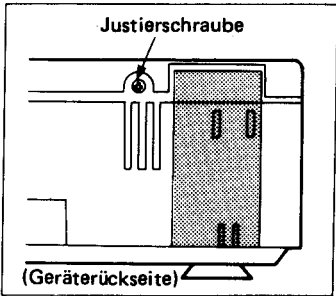
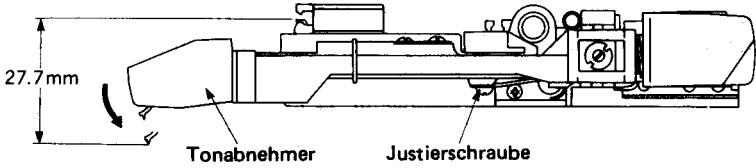
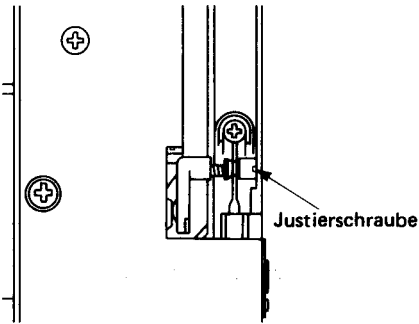
Schritt	Gegenstand	Justiermethode
1	Auto-Start-Position	<ol style="list-style-type: none"> 1 Überprüfen, daß der Tonarm in der Startposition (auf der Tonarmablage) ist. 2 Durch Drehen der Auto-Start-Positions-Justierschraube justieren. Bei Absenken des Tonarms zu weit innen: Die Justierschraube im Uhrzeigersinn drehen. Bei Absenken des Tonarms zu weit außen: Die Justierschraube entgegen dem Uhrzeigersinn drehen. <p>* Für die Justierung muß unbedingt eine 30 cm-Platte verwendet werden.</p>  <p style="text-align: center;">(Geräterückseite)</p>
2	Tonarm-lifthöhe	<ol style="list-style-type: none"> 1 Das Gerät so einstellen, wie in Abb. 1 gezeigt. 2 Den Netzschalter auf ON stellen und die Starttaste drücken, um den Tonarm nach innen zu bewegen. 3 Die Lifttaste drücken, so daß der Abstand zwischen der Tonabnehmer-Nadelspitze und der Führungsschiene 27.7 mm beträgt. Um den Abstand zu vergrößern die Justierschraube entgegen dem Uhrzeigersinn drehen. Um den Abstand zu verkleinern die Justierschraube im Uhrzeigersinn drehen. 
3	Tonarm-Reibungswinkel	<ol style="list-style-type: none"> 1 Das Gerät so einstellen, wie in Abb. 1 gezeigt. 2 Den Netzschalter auf ON stellen und die Starttaste drücken, um den Tonarm nach innen zu bewegen. 3 Die Reibungswinkel-Justierschraube drehen, bis die Armmitte mit der V-Kerbe am Liftbalken übereinstimmt. 

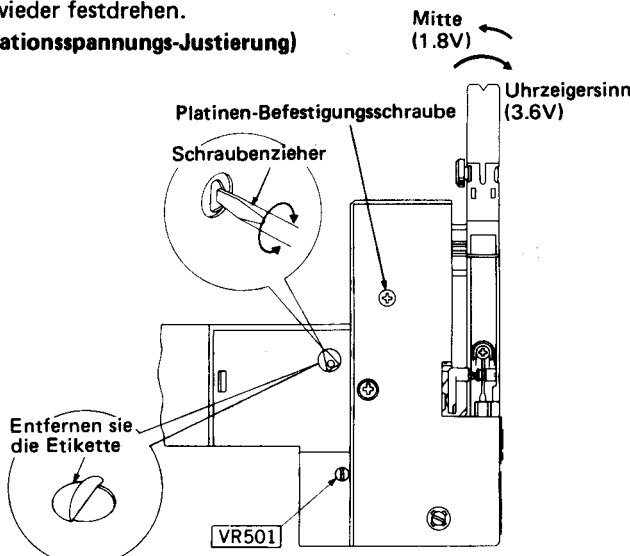
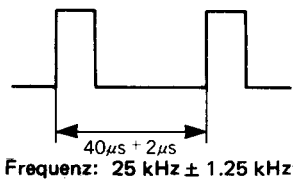
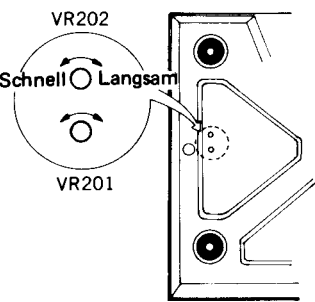
Schritt	Gegenstand	Justiermethode
4	<p>Servo-Verstärkungs- und Kompensations-Spannung</p>	<ol style="list-style-type: none"> 1 Das Gerät so einstellen, wie in Abb. 1 gezeigt. 2 Das elektronische Gleichstrom-Voltmeter an TP315 (Q306) Basis oder Anschluß CN301 Stift 2 und TP3 (Masse). 3 Den Netzschalter auf ON stellen und die Starttaste drücken, um den Tonarm nach innen zu bewegen. 4 Den Tonarm ganz nach rechts stellen. VR501 dann so einstellen, daß die Spannung 3.6V beträgt. (Servo-Verstärkungs-Justierung) 5 Den Tonarm in die Mitte stellen und überprüfen, daß die Ausgangsspannung 1.8V beträgt. 6 Falls die Spannung nicht 1.8V beträgt, die Platinen-Befestigungsschraube lösen und die Platine mit einem Schraubenzieher nach links oder rechts bewegen, bis die Ausgangsspannung 1.8V beträgt. Nach der Justierung, die Platinen-Befestigungsschraube wieder festdrehen. (Kompensationsspannungs-Justierung) 
5	<p>Zeitgeberfrequenz</p>	<ol style="list-style-type: none"> 1 Das Gerät so einstellen, wie in Abb. 1 gezeigt. 2 Das Klebband vom Gehäuseschalter entfernen. 3 Mit einem Klemmenkabel o.ä. TP7 (Q3 Emitter) mit TP326 (IC301 Stift 14) verbinden. 4 Das Oszilloskop oder den Frequenzzähler an TP316 (IC301 Stift 4) anschließen. 5 Den Netzschalter auf ON stellen. 6 VR301 so justieren, daß der Ausgangswellenform-Zyklus $40\mu\text{s} \pm 2\mu\text{s}$ beträgt. Ebenfalls VR301 so justieren, daß die Ausgangsfrequenz $25\text{ kHz} \pm 1.25\text{ kHz}$ beträgt. 
6	<p>Drehzahl</p>	<ol style="list-style-type: none"> 1 Das Gerät so einstellen, wie in Abb. 1 gezeigt. 2 Eine 17 cm-Platte abspielen. 3 VR202 drehen, um die Drehzahl auf die Nenndrehzahl zu justieren (45 U/min). 4 Eine 30 cm-Platte abspielen. 5 VR201 drehen, um die Drehzahl auf die Nenndrehzahl zu justieren (33-1/3 U/min). <p>Anmerkung: Unbedingt zuerst 45 U/min justieren.</p> 

MESURAGES ET RÉGLAGES Français

• Appareils utilisés

1. Voltmètre électronique à C.C.
2. Oscilloscope ou compteur de fréquence

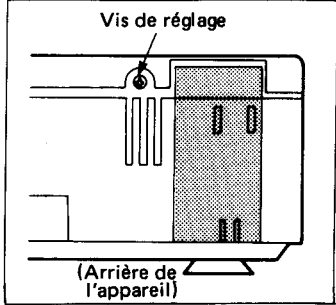
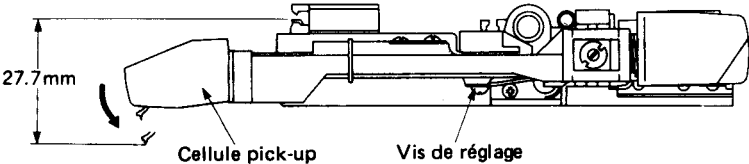
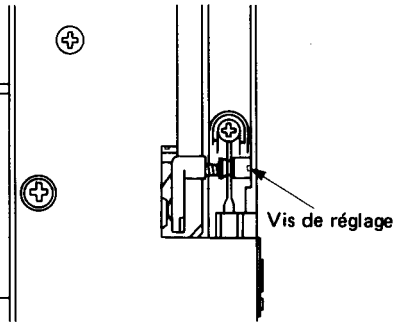
Etape	Article	Procédure de réglage
1	Position de démarrage automatique	<ol style="list-style-type: none"> 1 S'assurer que le bras de lecture est à la position de démarrage (sur l'accoudeur). 2 Ajuster en tournant la vis d'ajustement du positionnement de démarrage automatique. Le bras de lecture s'abaisse à l'intérieur du disque: Tourner la vis de réglage dans le sens des aiguilles d'une montre. Le bras de lecture s'abaisse à l'extérieur du disque: Tourner la vis de réglage dans le sens inverse des aiguilles d'une montre. *S'assurer d'utiliser un disque de 30 cm pour la mise au point.  <p style="text-align: center;">(Arrière de l'appareil)</p>
2	Hauteur d'élévation du bras	<ol style="list-style-type: none"> 1 Effectuer le réglage comme il est illustré à la Fig. 20. 2 Mettre l'interrupteur d'alimentation sur "on" (marche) et appuyer sur le bouton de mise en marche pour déplacer le bras de lecture vers l'intérieur. 3 Appuyer sur le bouton de pose/relevage de façon à ce que la distance entre l'extrémité de la pointe de lecture de la cellule pick-up et le rail de guidage soit de 27.7 mm. Pour augmenter la distance Tourner la vis de réglage dans le sens inverse des aiguilles d'une montre. Pour diminuer la distance Tourner la vis de réglage dans le sens des aiguilles d'une montre.  <p style="text-align: center;">Cellule pick-up Vis de réglage</p>
3	Angle de décalage du bras de lecture	<ol style="list-style-type: none"> 1 Effectuer le réglage comme il est illustré à la Fig. 20. 2 Mettre l'interrupteur d'alimentation sur "on" (marche) et appuyer sur le bouton de mise en marche pour déplacer le bras de lecture vers l'intérieur. 3 Tourner la vis de réglage de l'angle de décalage de façon à ce que le centre du bras coïncide avec la rainure en V de la tige d'élévation.  <p style="text-align: center;">Vis de réglage</p>

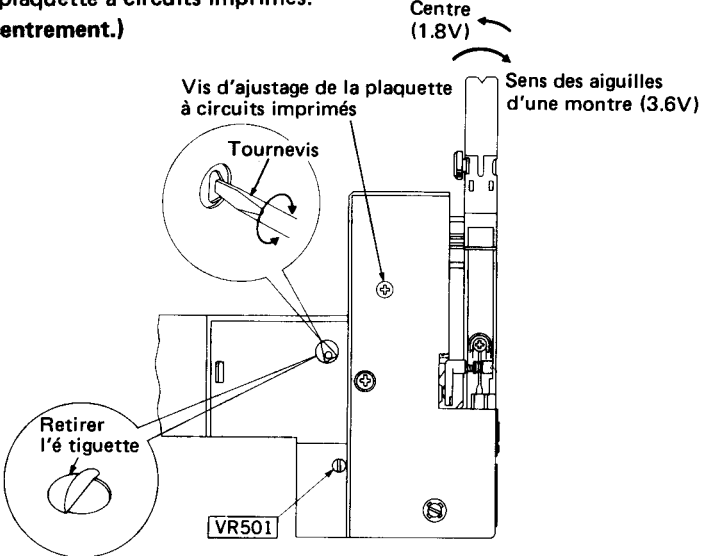
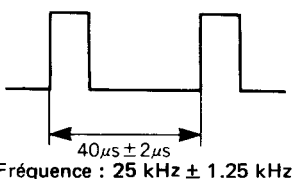
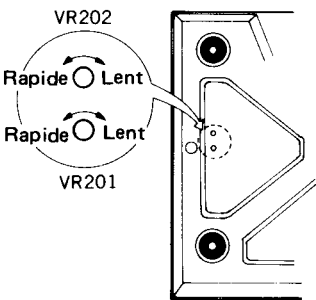
Etape	Article	Procédure de réglage
4	Amplification servo-mécanique et tension de suppression.	<ol style="list-style-type: none"> 1 Effectuer le réglage comme il est illustré à la Fig. 20. 2 Brancher un voltmètre électronique à C.C. à la base de TP315 (Q306) ou à la borne 3 du connecteur CN301 et de TP3 (mise à la terre). 3 Mettre l'interrupteur d'alimentation sur "on" (marche) et appuyer sur le bouton de mise en marche pour déplacer le bras de lecture vers l'intérieur. 4 Déplacer complètement le bras de lecture vers la droite. Puis, ajuster VR501 de façon à ce que la tension soit de 3.6V. (Réglage de l'amplification servo-mécanique.) 5 Placer le bras de lecture au centre et s'assurer que la tension de sortie soit de 1.8V. 6 Si la tension n'est pas de 1.8V, desserrer la vis d'ajustage de la plaquette à circuits imprimés et déplacer la plaquette vers la droite ou vers la gauche avec un tournevis, de façon à ce que la tension de sortie soit de 1.8V. Après la mise au point, resserrer la vis d'ajustage de la plaquette à circuits imprimés. (Mise au point du décentrement.) 
5	Fréquence des impulsions d'horloge	<ol style="list-style-type: none"> 1 Effectuer le réglage comme il est montré à la Fig. 20. 2 Retirer la bande du dispositif de commutation du boîtier. 3 Connecter TP7 (émetteur Q3) à TP326 (broche 14 de IC301) avec un fil de raccordement à pince ou quelquechose de similaire. 4 Brancher l'oscilloscope ou le compteur de fréquence à TP316 (broche 4 de IC301). 5 Mettre l'interrupteur d'alimentation sur "on" (marche). 6 Régler VR301 de façon à ce que le cycle de la forme d'onde de sortie soit de $40\mu s \pm 2\mu s$. En outre, régler VR301 de façon à ce que la fréquence de sortie soit de $25\text{ kHz} \pm 1.25\text{ kHz}$. 
6	Vitesse rotationnelle	<ol style="list-style-type: none"> 1 Effectuer le réglage comme il est illustré à la Fig. 20. 2 Faire jouer un disque de 17 cm. 3 Tourner VR202 pour ajuster la vitesse à la vitesse nominale de rotation (45 t/p.m.) 4 Faire jouer un disque de 30 cm. 5 Tourner VR201 pour régler la vitesse à la vitesse nominale de rotation (33-1/3 t/p.m.) <p>Note: S'assurer de régler tout d'abord un 45 t/p.m.</p> 

MEDICIONES Y AJUSTE Español

● Instrumentos usados

1. Voltímetro electrónico CC.
2. Osciloscopio o contador de frecuencia

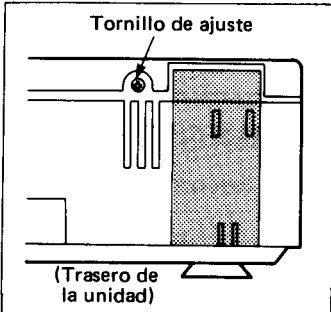
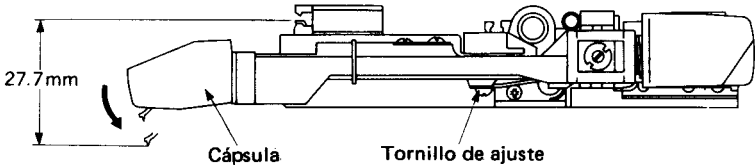
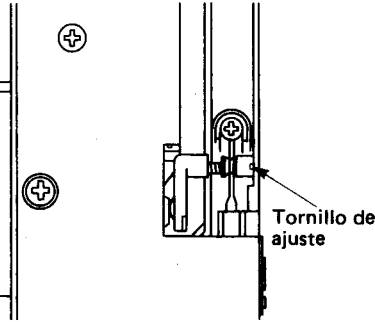
Paso	Item	Procedimiento de ajuste
1	Posición de arranque automático	<ol style="list-style-type: none"> 1 Asegúrese de que el brazo del fonocaptor está en la posición de arranque (en el soporte). 2 Ajuste girando el tornillo de ajuste de posición de arranque automático. <p>El brazo del fonocaptor baja dentro del disco: Gire el tornillo de ajuste a la derecha.</p> <p>El brazo del fonocaptor baja fuera del disco: Gire el tornillo de ajuste a la izquierda.</p> <p>*Para el ajuste, asegúrese de usar un disco de gramófono de 30 cm.</p>  <p style="text-align: center;">(Trasero de la unidad)</p>
2	Altura de alzo de brazo	<ol style="list-style-type: none"> 1 Coloque la unidad como se ilustra en la Fig. 20. 2 Conecte el interruptor de la corriente y apriete el botón de arranque para desviar el brazo del fonocaptor hacia dentro. 3 Apriete el botón de colocación en surco de la aguja, de manera que la distancia entre la punta de la aguja de la cápsula y el riel de guía sea 27.7 mm. <p>Para aumentar la distancia gire el tornillo de ajuste a la izquierda.</p> <p>Para disminuir la distancia gire el tornillo de ajuste a la derecha.</p>  <p style="text-align: center;">Cápsula Tornillo de ajuste</p>
3	Angulo del brazo del fonocaptor	<ol style="list-style-type: none"> 1 Coloque la unidad como se ilustra en la Fig. 20. 2 Conecte el interruptor de la corriente y apriete el botón de arranque para desviar el brazo del fonocaptor hacia dentro. 3 Gire el tornillo de ajuste del ángulo del brazo del fonocaptor de manera que el centro del brazo coincida con la ranura-V de la barra de alza.  <p style="text-align: right;">Tornillo de ajuste</p>

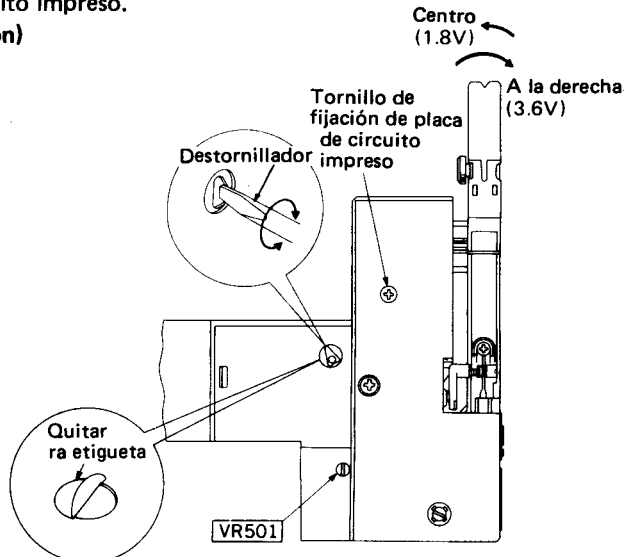
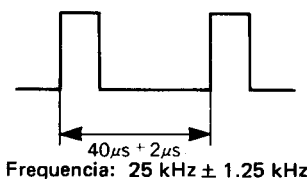
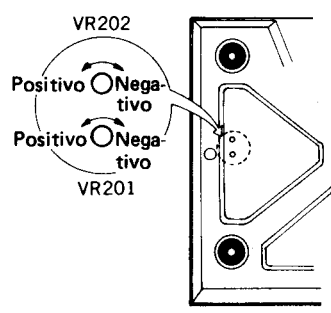
Paso	Item	Procedimiento de ajuste
4	Contratensión y servogancia	<ol style="list-style-type: none"> Coloque la unidad como se ilustra en la Fig. 20. Conecte el voltímetro electrónico CC a base de TP315 (Q306) o terminal 3 CN301 del conector y TP3 (tierra). Conecte el interruptor de la corriente y apriete el botón de arranque para desviar el brazo del fonocaptor hacia dentro. Desvíe completamente el brazo del fonocaptor a la derecha. Luego, ajuste VR501 de manera que la tensión sea 3.6V. (Ajuste de servogancia) Coloque el brazo del fonocaptor en el centro y asegúrese de que la tensión de salida sea 1.8V. Si la tensión no es 1.8V, afloje el tornillo de fijación de la placa del circuito impreso y mueva la placa a la derecha o izquierda mediante un destornillador de manera que la tensión de salida se haga 1.8V. Después del ajuste, apriete el tornillo de fijación de la placa del circuito impreso. (Ajuste de desviación) 
5	Frecuencia de reloj	<ol style="list-style-type: none"> Coloque la unidad como se ilustra en la Fig. 20. Remueva la cinta del interruptor del gabinete. Conecte TP7 (emisor Q3) a TP326 (púa 14 de IC301) con un cordón con presilla o algo parecido. Conecte el osciloscopio o el contador de frecuencia a TP316 (púa 4 de IC301). Conecte el interruptor de la corriente. Ajuste VR301 de manera que el ciclo de forma de onda de salida sea $40\mu s \pm 2\mu s$. También, ajuste VR301 de manera que la frecuencia de salida sea $25\text{ kHz} \pm 1.25\text{ kHz}$. 
6	Velocidad rotacional	<ol style="list-style-type: none"> Coloque la unidad como se ilustra en la Fig. 20. Toque un disco de 17 cm. Gire VR202 para ajustar la velocidad a la velocidad de régimen (45 r.p.m.) Toque un disco de 30 cm. Gire VR201 para ajustar la velocidad a la velocidad de régimen (33-1/3 r.p.m.) <p>Nota: Asegúrese de ajustar a 45 r.p.m. primero.</p> 

REPLACEMENT PARTS LIST... Electric Parts

- Notes:**
1. Part numbers are indicated on most mechanical parts. Please use this part number for parts orders.
 2. Important safety notice: Components identified by Δ mark have special characteristics important for safety. When replacing any of these components, use only manufacturer's specified parts.
 3. Bracketed indications in Ref. No. columns specify the area. Parts without these indications can be used for all areas.
 4. The "S" mark is service standard parts and may differ from production parts.

Areas

- * [E] is available in Switzerland and Scandinavia.
- * [EK] is available in United Kingdom.
- * [XL] is available in Australia.
- * [EG] is available in F.R. Germany.
- * [EB] is available in Belgium.
- * [EF] is available in France.
- * [XA] is available in Southeast Asia, Oceania, Africa, Middle Near East and Central South America.
- * [EH] is available in Holland.
- * [Ei] is available in Italy.
- * [EC] is available in Czechoslovakia.

Ref. No.	Part No.	Part Name & Description
INTEGRATED CIRCUITS		
IC101	AN6636	IC, Drive
IC301	MN1421FPB	IC, Micro Computer
IC401	AN6554	IC, Operation Amplifier
TRANSISTORS		
Q1	2SD549	Transistor, Regulator
Q2	2SD636	Transistor, Regulator
Q3	2SD638	Transistor, Regulator
Q101, 102	2SD636	Transistor, Regulator & Switching
Q201	2SA1015-Y	Transistor, Switching
Q301 ~ 303	2SD636	Transistor, Switching
Q304	2SD892	Transistor, Cueing Control
Q305, 307	2SB641	Transistor, Switching
Q306	2SD636	Transistor, V/I Converter
Q308, 309	2SD636	Transistor, Wave form Shaping
Q310	2SB641	Transistor, Wave form Shaping
Q401, 402	2SD592NC-R	Transistor, Tonearm Motor Control
Q403, 404	2SD638	Transistor, Tonearm Motor Control
DIODES		
D1	Δ SVDSIRBA20Z	Rectifier
D2	S MA1056	Diode
D301	MA1075A	Diode
D302	S SVDPR6531K	Light Emitting Diode
D303 ~ 306	S MA162A	Diode
D501	S MA162A	Diode
D502	SVDPR3432S	Light Emitting Diode
PHOTO INTERRUPTERS		
PC501	ON1262	Photo Interrupter
PC601	ON1261	Photo Interrupter
RELAY		
RL501	SFDYAW6945	Relay, Muting
SWITCHES		
S1	Δ SFDSC05N08	Switch, Power
S301	SFDSC05N01	Switch, Record Detector
S302 ~ 305	EVQQR02K	Switch, Start, Stop, Repeat & Cueing
S306	SFDSHSW0699	Switch, Speed Select
S601	SFDSD2MSL-C	Switch, Rest
S701	SFDSC05N01	Switch, Disc Size Selector
S702	SFDSC05N02	Switch, Rest
S901 [XA] only	Δ SFDSHXW225-2	Switch, Voltage Adjuster
VARIABLE RESISTORS		
VR201, 202	EVNM6AA00B24	Speed Adjustment, 20k Ω (B)
VR301	EVNKG6JA00B24	Clock Frequency Adjustment, 20k Ω (B)
VR501	EVNKG6JA00B53	Servo Gain Adjustment, 5k Ω (B)
FUSE		
F1 [XA]	Δ XBA2C02T1B	Fuse, T200mA 250V
F1 [Other Areas]	Δ XBA2C06T1B	Fuse, T630mA 250V
F2 [XA] only	Δ XBA2C06T1B	Fuse, T630mA 250V
THERMISTER		
R504	ERTD2FFK251S	Thermister
HALL ELEMENT		
H1, 2	OH-001	Hall Element, Turntable Position Detector
POWER TRANSFORMER		
T1 [EK, XL]	Δ SLT48DT4E	Power Transformer
T1 [XA]	Δ SLT57DTL1A	Power Transformer
T1 [Other Areas]	Δ SLT48DT3E	Power Transformer

Ref. No.	Part No.	Part Name & Description
RESISTORS		
R1	S ERD25FJ472	Carbon, 1/4W, 4.7k Ω , \pm 5%
R2	S ERD25FJ331	Carbon, 1/4W, 330 Ω , \pm 5%
R3	S ERD25FJ152	Carbon, 1/4W, 1.5k Ω , \pm 5%
R4, 5	S ERD25FJ332	Carbon, 1/4W, 3.3k Ω , \pm 5%
R6	S ERD25FJ330	Carbon, 1/4W, 33 Ω , \pm 5%
R101	S ERX1ANJ2R7	Metal Oxide, 1W, 2.7k Ω , \pm 5%
R102	S ERD25FJ270	Carbon, 1/4W, 27 Ω , \pm 5%
R103	S ERD25FJ182	Carbon, 1/4W, 1.8k Ω , \pm 5%
R104	S ERD25FJ332	Carbon, 1/4W, 3.3k Ω , \pm 5%
R106	S ERD25FJ562	Carbon, 1/4W, 5.6k Ω , \pm 5%
R201	S ERD25FJ102	Carbon, 1/4W, 1k Ω , \pm 5%
R202	S ERD25TJ153	Carbon, 1/4W, 15k Ω , \pm 5%
R203	S ERD25FJ102	Carbon, 1/4W, 1k Ω , \pm 5%
R204	S ERD25TJ153	Carbon, 1/4W, 15k Ω , \pm 5%
R205, 206	S ERD25TJ104	Carbon, 1/4W, 100k Ω , \pm 5%
R207	S ERO25CKF2702	Metal Film, 1/4W, 27k Ω , \pm 5%
R208	S ERD25FJ562	Carbon, 1/4W, 5.6k Ω , \pm 5%
R209	S ERO25CKF8202	Metal Film, 1/4W, 82k Ω , \pm 1%
R210	S ERD25FJ471	Carbon, 1/4W, 470 Ω , \pm 5%
R211	S ERD25FJ472	Carbon, 1/4W, 4.7k Ω , \pm 5%
R212	S ERD25TJ333	Carbon, 1/4W, 33k Ω , \pm 5%
R301	S ERD25FJ103	Carbon, 1/4W, 10k Ω , \pm 5%
R302, 303	S ERD25FJ472	Carbon, 1/4W, 4.7k Ω , \pm 5%
R304, 305	S ERD25FJ472	Carbon, 1/4W, 4.7k Ω , \pm 5%
R306	S ERD25FJ102	Carbon, 1/4W, 1k Ω , \pm 5%
R307	S ERD25FJ472	Carbon, 1/4W, 4.7k Ω , \pm 5%
R308	S ERD25FJ331	Carbon, 1/4W, 330 Ω , \pm 5%
R310	S ERD25FJ562	Carbon, 1/4W, 5.6k Ω , \pm 5%
R312, 313	S ERD25TJ333	Carbon, 1/4W, 33k Ω , \pm 5%
R314, 315	S ERD25TJ333	Carbon, 1/4W, 33k Ω , \pm 5%
R316	S ERD25TJ333	Carbon, 1/4W, 33k Ω , \pm 5%
R317	S ERD25FJ272	Carbon, 1/4W, 2.7k Ω , \pm 5%
R318, 319	S ERD25FJ332	Carbon, 1/4W, 3.3k Ω , \pm 5%
R320	S ERD25FJ272	Carbon, 1/4W, 2.7k Ω , \pm 5%
R321, 322	S ERD25FJ331	Carbon, 1/4W, 330 Ω , \pm 5%
R323	S ERD25FJ562	Carbon, 1/4W, 5.6k Ω , \pm 5%
R324	S ERD25TJ223	Carbon, 1/4W, 22k Ω , \pm 5%
R325	S ERD25FJ103	Carbon, 1/4W, 10k Ω , \pm 5%
R326	S ERD25FJ222	Carbon, 1/4W, 2.2k Ω , \pm 5%
R327	S ERD25TJ223	Carbon, 1/4W, 22k Ω , \pm 5%
R328	S ERD25TJ473	Carbon, 1/4W, 4.7k Ω , \pm 5%
R329, 330	S ERD25FJ332	Carbon, 1/4W, 3.3k Ω , \pm 5%
R331	S ERD25FJ102	Carbon, 1/4W, 1k Ω , \pm 5%
R332	S ERD25FJ562	Carbon, 1/4W, 5.6k Ω , \pm 5%
R333	S ERD25FJ152	Carbon, 1/4W, 1.5k Ω , \pm 5%
R334	S ERD25FJ222	Carbon, 1/4W, 2.2k Ω , \pm 5%
R335	S ERD25TJ104	Carbon, 1/4W, 100k Ω , \pm 5%
R336	S ERD25FJ682	Carbon, 1/4W, 6.8k Ω , \pm 5%
R337	S ERD25TJ273	Carbon, 1/4W, 27k Ω , \pm 5%
R338	S ERD25FJ222	Carbon, 1/4W, 2.2k Ω , \pm 5%
R339	S ERD25TJ123	Carbon, 1/4W, 12k Ω , \pm 5%
R340	S ERD25FJ272	Carbon, 1/4W, 2.7k Ω , \pm 5%
R341	S ERD25FJ222	Carbon, 1/4W, 2.2k Ω , \pm 5%
R401	S ERD25TJ683	Carbon, 1/4W, 68k Ω , \pm 5%
R402	S ERD25TJ683	Carbon, 1/4W, 68k Ω , \pm 5%
R403	S ERD25FJ472	Carbon, 1/4W, 4.7k Ω , \pm 5%
R404	S ERD25FJ122	Carbon, 1/4W, 1.2k Ω , \pm 5%
R405	S ERD25FJ222	Carbon, 1/4W, 2.2k Ω , \pm 5%
R406	S ERD25FJ102	Carbon, 1/4W, 1k Ω , \pm 5%
R407	S ERD25TJ224	Carbon, 1/4W, 220k Ω , \pm 5%
R408	S ERD25FJ222	Carbon, 1/4W, 2.2k Ω , \pm 5%
R409	S ERD25FJ102	Carbon, 1/4W, 1k Ω , \pm 5%
R410	S ERD25TJ224	Carbon, 1/4W, 220k Ω , \pm 5%
R411	S ERD25FJ272	Carbon, 1/4W, 2.7k Ω , \pm 5%
R412	S ERD25FJ681	Carbon, 1/4W, 680 Ω , \pm 5%
R501	S ERD25FJ331	Carbon, 1/4W, 330 Ω , \pm 5%

Ref. No.	Part No.	Part Name & Description
R502	S ERD25FJ561	Carbon, 1/4W, 560Ω, ± 5%
R503	S ERD25FJ221	Carbon, 1/4W, 220Ω, ± 5%
R601	S ERD25FJ681	Carbon, 1/4W, 680Ω, ± 5%
CAPACITORS		
C1, 2	S Δ ECKD1H223PF	Ceramic, 50V, 0.022μF, ± 100%
C3	S Δ ECKD1H223PF	Ceramic, 50V, 0.022μF, ± 100%
C4	S Δ ECEB1VS102	Electrolytic, 35V, 1000μF
C5	S ECEA1HS100	Electrolytic, 50V, 10μF
C101	S ECQM1H333JZ	Polyester, 50V, 0.033μF, ± 5%
C102	S ECEA1ES101	Electrolytic, 25V, 100μF
C103, 104	Δ ECEA1CN101S	Electrolytic, 16V, 100μF
C105	S ECEA1CS330	Electrolytic, 16V, 33μF
C106	S ECKD1H223PF	Ceramic, 50V, 0.022μF, ± 100%
C201	S ECQM1H104JZ	Polyester, 50V, 0.1μF, ± 5%
C202	S ECEA25Z4R7	Electrolytic, 25V, 4.7μF
C203	S ECQM1H104JZ	Polyester, 50V, 0.1μF, ± 5%

Ref. No.	Part No.	Part Name & Description
C204	S ECQM1H473JZ	Polyester, 50V, 0.047μF, ± 5%
C205	S ECQM1H333JZ	Polyester, 50V, 0.033μF, ± 5%
C206	S ECQM1H224JZ	Polyester, 50V, 0.22μF, ± 5%
C207	S ECQM1H104JZ	Polyester, 50V, 0.1μF, ± 5%
C208	S ECQV05224JZ	TF, 50VDC, 0.22μF, ± 5%
C209	S ECEA50Z3R3	Electrolytic, 50V, 3.3μF
C210	S ECKD1H223PF	Ceramic, 50V, 0.022μF, ± 100%
C211	S ECKD2H102KB	Ceramic, 500V, 0.001μF, ± 5%
C301	S ECCD1H101K	Ceramic, 50V, 100μF, ± 5%
C302	S ECQM1H104KZ	Polyester, 50V, 0.1μF, ± 5%
C304	S ECEA1AS101	Electrolytic, 10V, 100μF, ± 5%
C305	S ECKD1H561KB	Ceramic, 50V, 560μF, ± 5%
C306	S ECKF1E104ZV	Ceramic, 25V, 0.1μF, ± 80%
C401	S ECQM1H223JZ	Polyester, 50V, 0.022μF, ± 5%
C402	S ECQM1H223JZ	Polyester, 50V, 0.022μF, ± 5%
C501	S ECEA1ES101	Electrolytic, 25V, 100μF
C601	S ECFB1B104ZRM	Ceramic, 50V, 0.1μF

TIMING CHART

30 cm Record

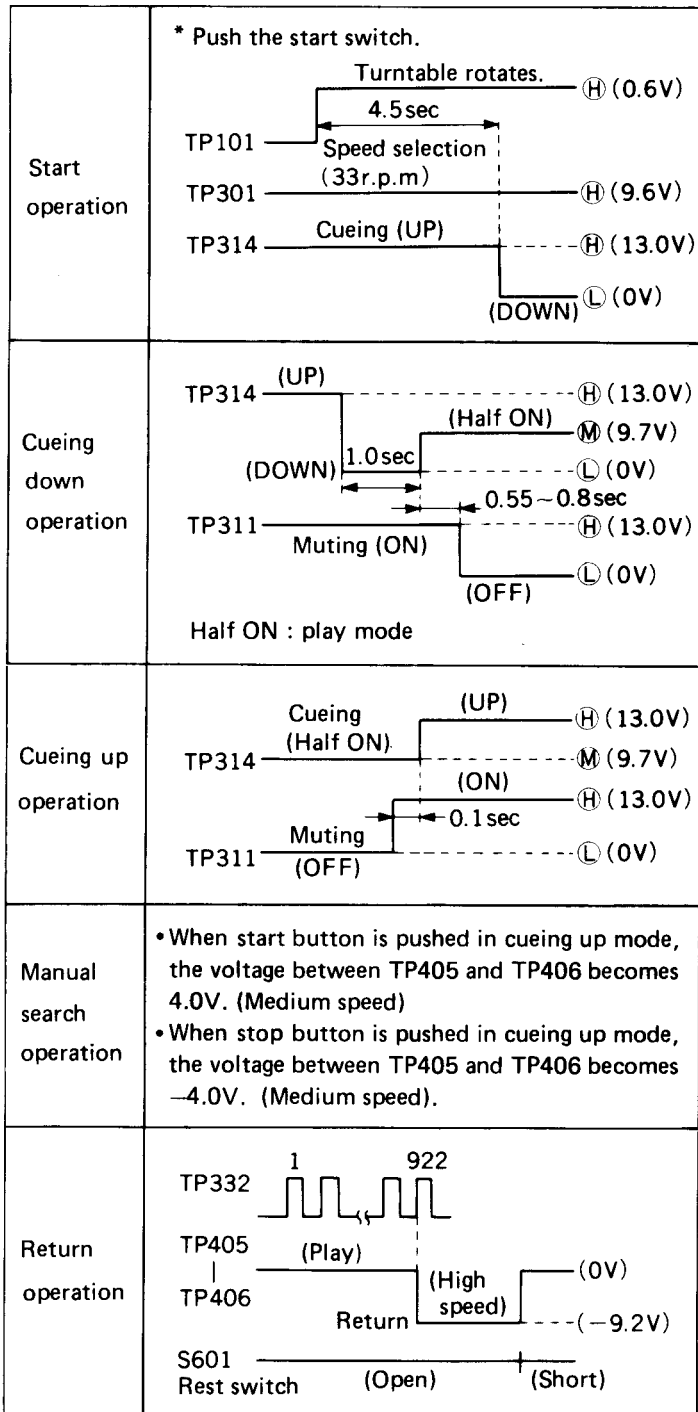

17 cm Record

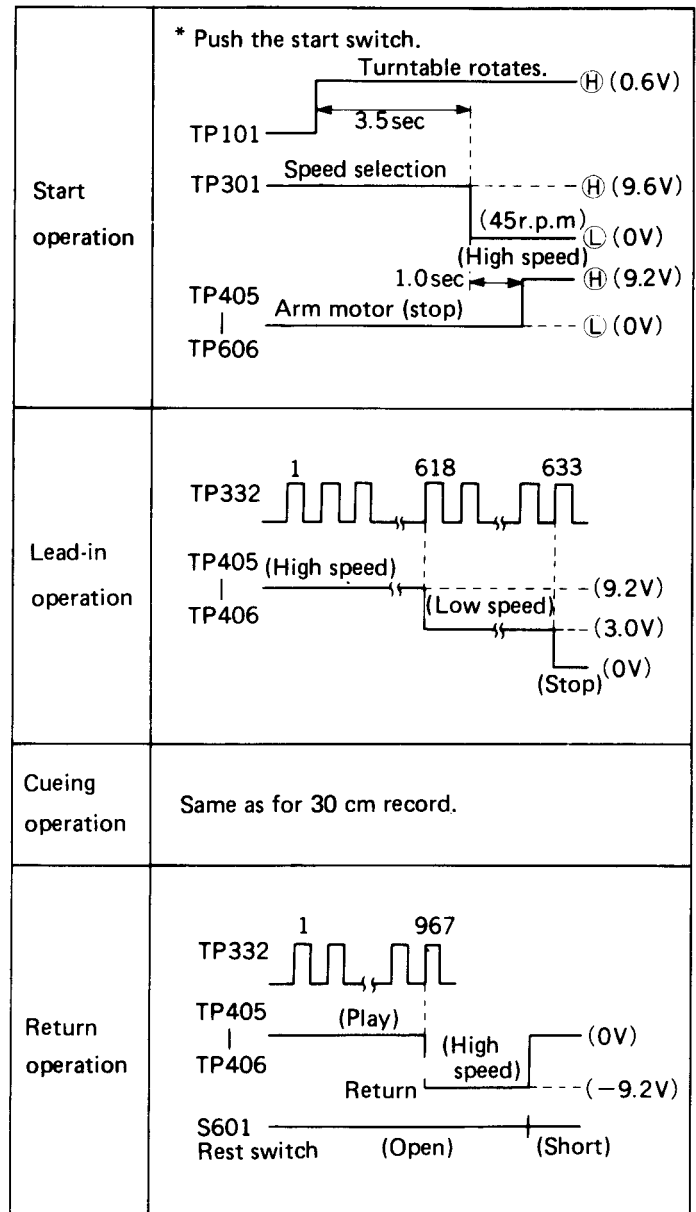

■ BLOCK DIAGRAM

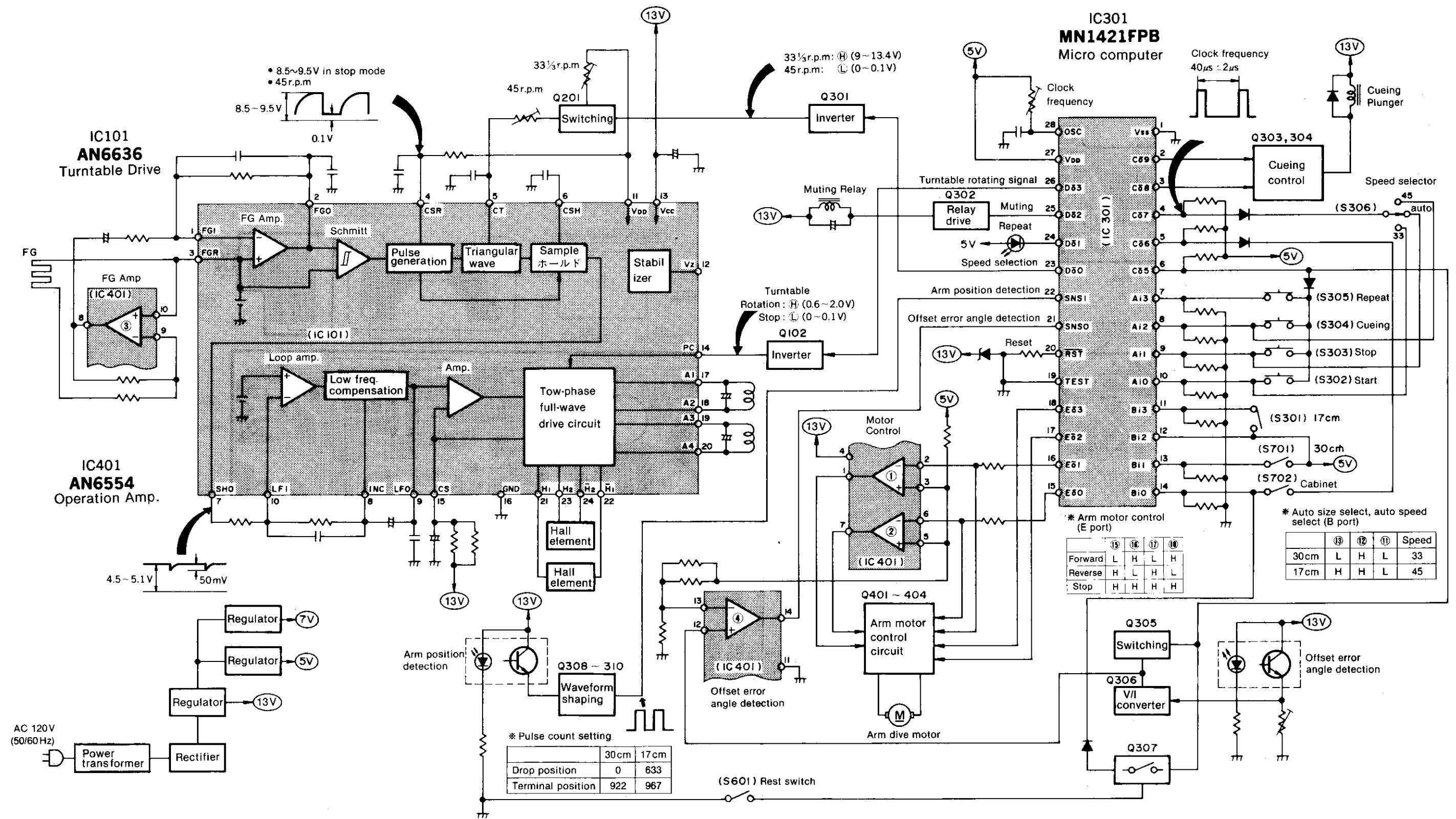

* Pulse count setting

	30cm	17cm
Drop position	0	633
Terminal position	922	967

* Arm motor control (E port)

	15	16	17	18
Forward	L	H	L	H
Reverse	H	L	H	L
Stop	H	H	H	H

* Auto size select, auto speed select (B port)

	13	12	11	Speed
30cm	L	H	L	33
17cm	H	H	L	45

CIRCUIT BOARD AND WIRING CONNECTION DIAGRAM

Ground (Earth) lines

Terminal guide of transistors, diodes and IC's

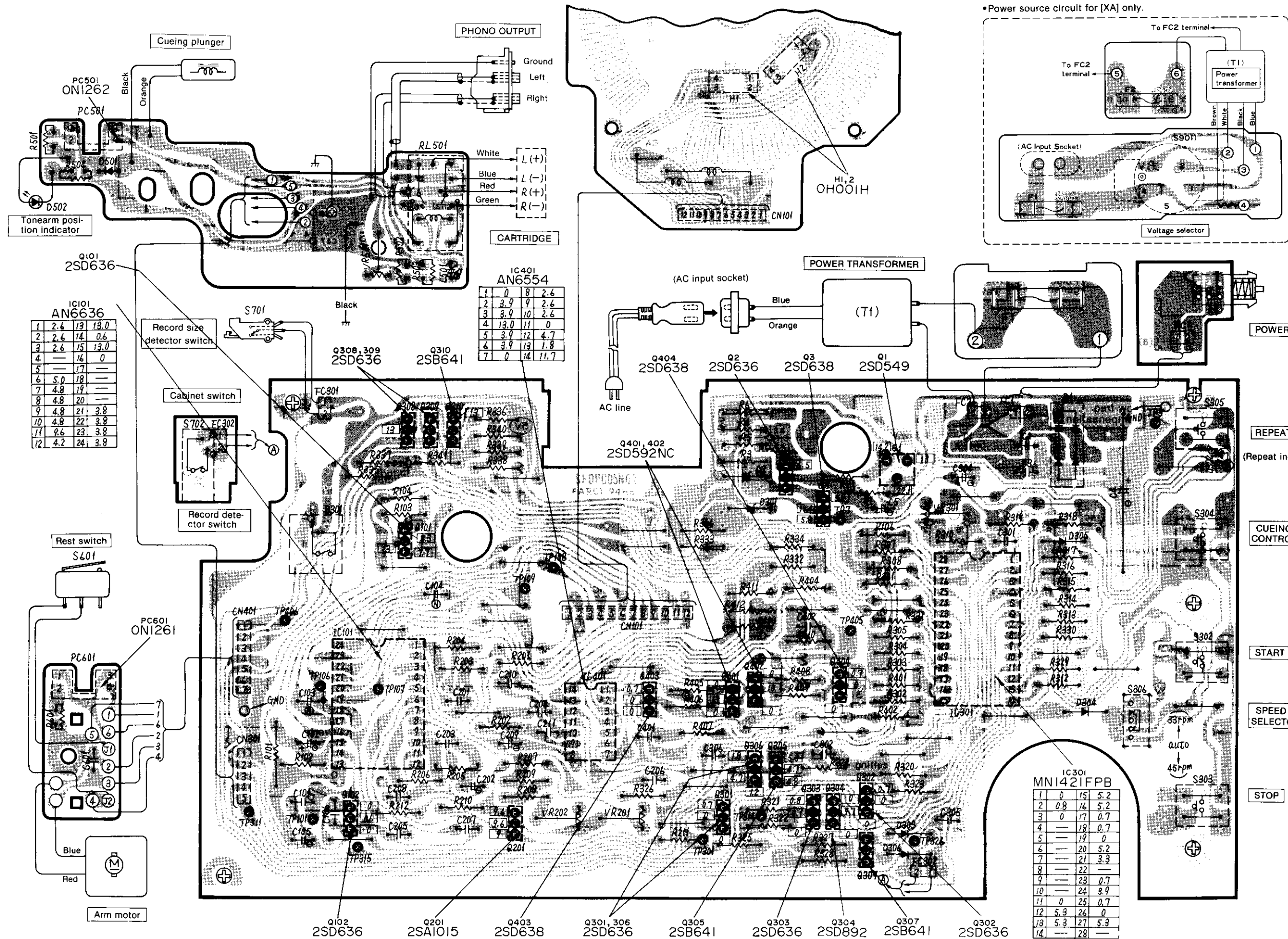

IC101 AN6636

1	2.6	13	13.0
2	2.6	14	0.6
3	2.6	15	13.0
4	4.8	16	0
5	—	17	—
6	5.0	18	—
7	4.8	19	—
8	4.8	20	—
9	4.8	21	3.8
10	4.8	22	3.8
11	2.6	23	3.8
12	4.2	24	3.8

IC401 AN6554

1	0	8	2.6
2	3.9	9	2.6
3	3.9	10	2.6
4	13.0	11	0
5	3.9	12	4.7
6	3.9	13	1.8
7	0	14	11.7

IC301 MNI421FPB

1	0	15	5.2
2	0.8	16	5.2
3	0	17	0.7
4	—	18	0.7
5	—	19	0
6	—	20	5.2
7	—	21	3.9
8	—	22	—
9	—	23	0.7
10	—	24	3.9
11	0	25	0.7
12	5.3	26	0
13	5.3	27	5.3
14	—	28	—

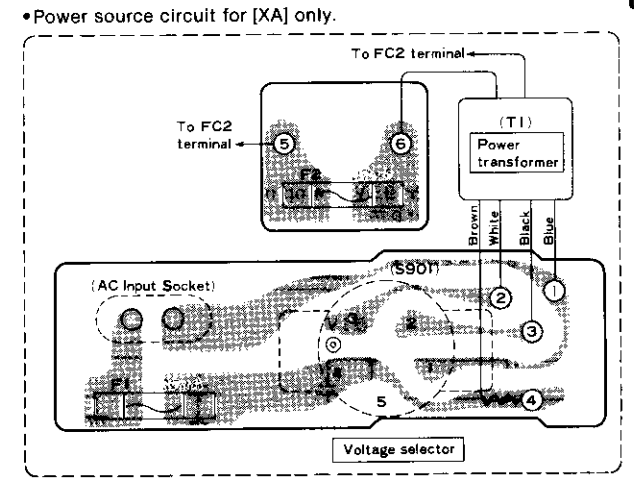

Terminal guide of transistors, diodes and IC's

- AN6636**: 7-pin IC terminal diagram.
- MNI421FPB**: 14-pin IC terminal diagram.
- AN6554**: 7-pin IC terminal diagram.
- 2SD549**: Transistor terminal diagram.
- 2SA1015, 2SD592NC, 2SD892**: Transistor terminal diagram.
- 2SB641, 2SD636, 2SD638**: Transistor terminal diagram.
- ON1261**: Diode terminal diagram.
- ON1262**: Diode terminal diagram.

SCHEMATIC DIAGRAM (This schematic diagram may be modified at any time with the development of new technology.)

Notes:

1. **S1** : On/off switch in "on" position.
2. **S301** : Record detector switch in "off" position. (It detects the record on the turn table.)
3. **S302** : Start switch in "off" position. (It is not pushed.)
4. **S303** : Stop switch in "off" position. (It is not pushed.)
5. **S304** : Cueing control switch in "off" position. (It is not pushed.)
6. **S305** : Repeat switch in "off" position. (It is not pushed.)
7. **S306** : Speed selector switch in "auto" position. 33 rpm ↔ auto ↔ 45 rpm
8. **S601** : Rest switch in "off" position. (Tonearm is off the rest position.)
9. **S701** : Record size detector switch in "on" position. (17 cm record is on the turntable.)
10. **S702** : Cabinet switch in "on" position. (Upper cabinet is closed.)
11. **S901** : Voltage selector in "110 - 120V" position. 110 - 120V ↔ 220 - 240V
12. Indicated voltage values are the standard values for the measured by the DC electronic circuit tester (high-impedance) with the chassis taken as standard. Therefore, there may exist some errors in the voltage values, depending on the internal impedance of the DC circuit tester or the set measured.
 - \square is the voltage at 45 rpm.
 - \square is the voltage at 33 rpm.
 - $\langle \rangle$ is the voltage when tonearm is in lead-in mode.
 - $\langle \rangle$ is the voltage when tonearm is in return mode.
 - \square is the voltage when turntable is in stop.
 - \square is the voltage when tonearm is at the rest position.
 - \square is the terminal that changes according to 5V pulse waveform or key switch position.

13. — Positive voltage lines.
14. Important safety notice: Components identified by Δ mark have special characteristics important for safety. When replacing any of these components, use only manufacturer's specified parts.

• Power source circuit for [XA] only.

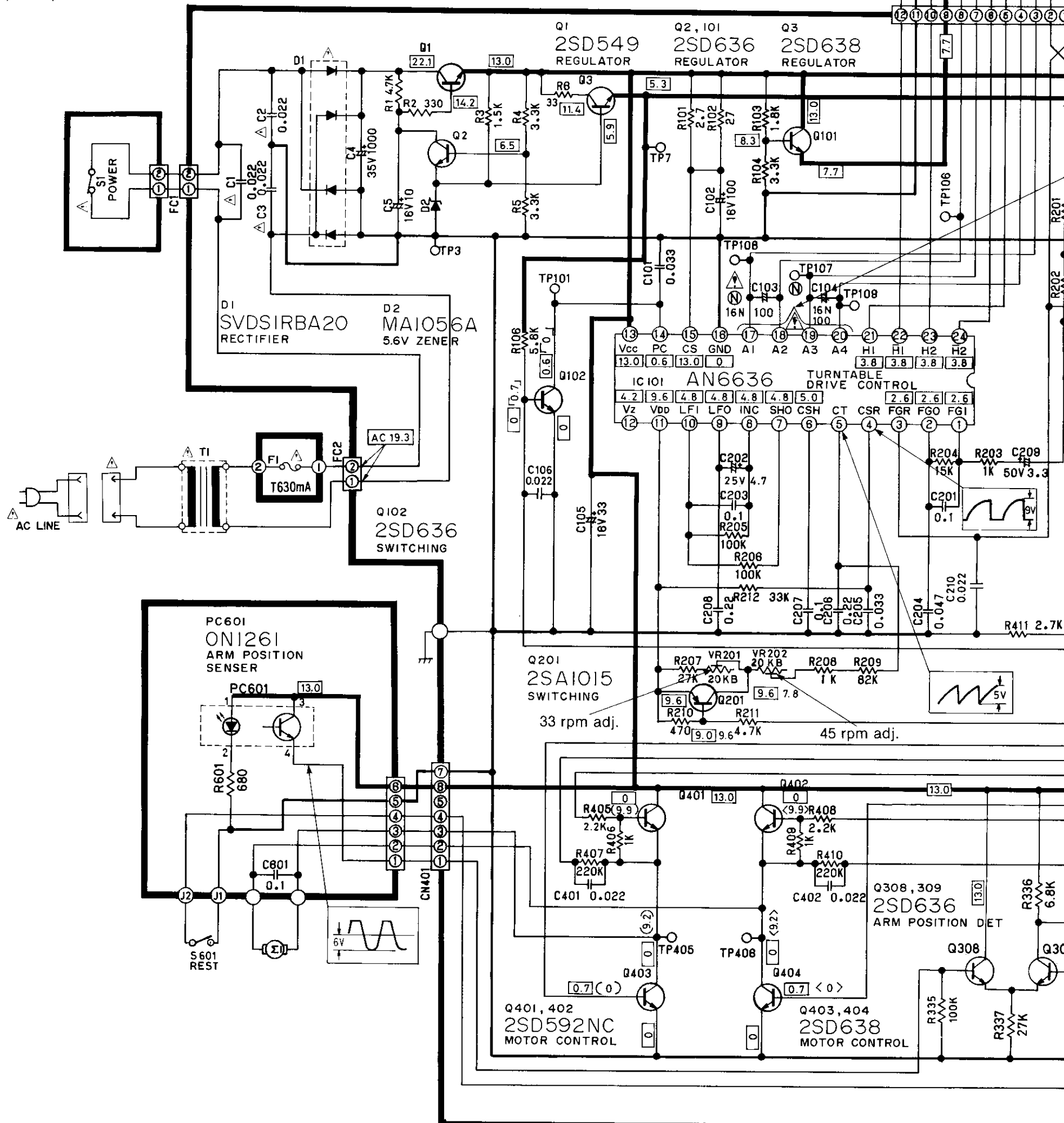
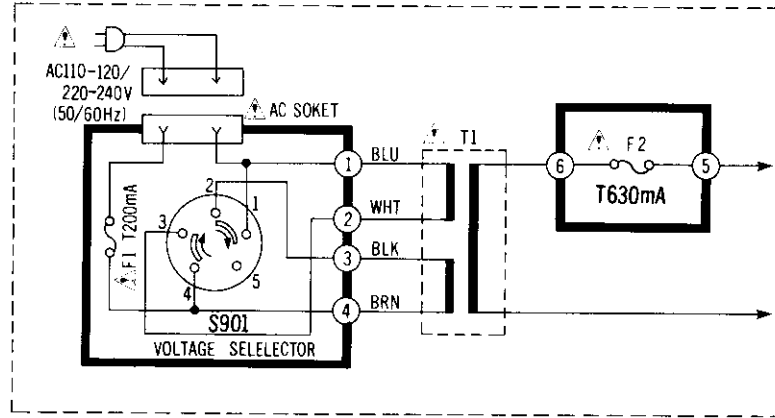

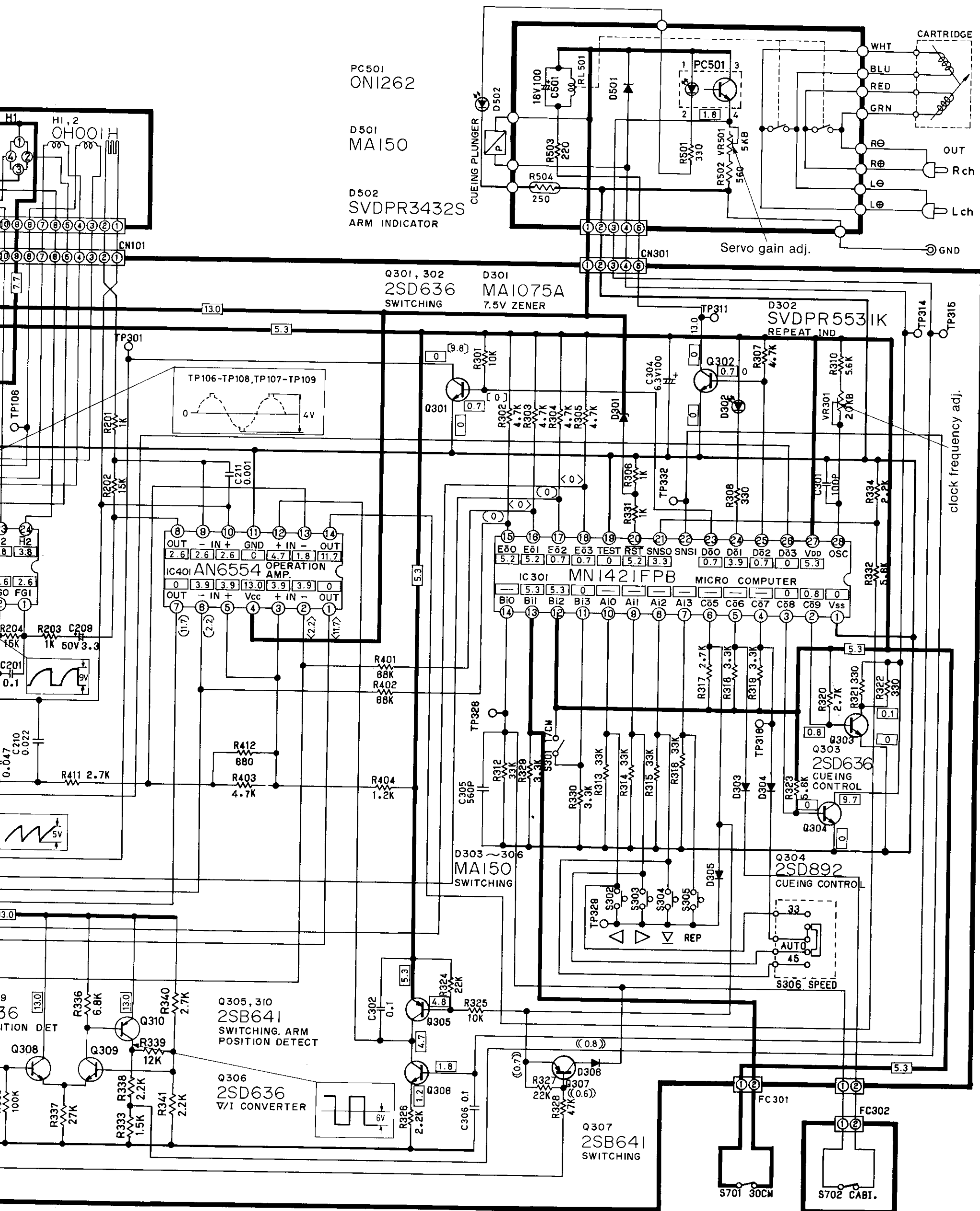

PC501
ON1262

D501
MA150

D502
SVDPR3432S
ARM INDICATOR

Q301, 302
2SD636
SWITCHING

D301
MA1075A
7.5V ZENER

D302
SVDPR5531K
REPEAT IND

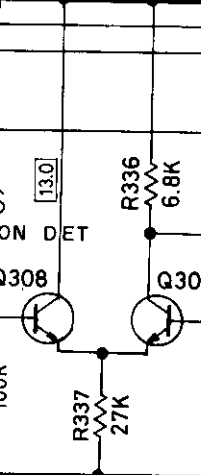
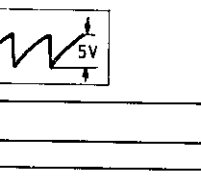
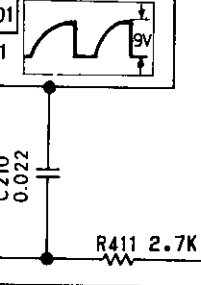
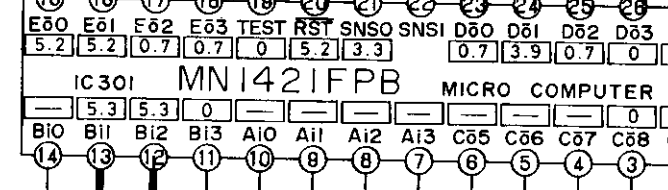
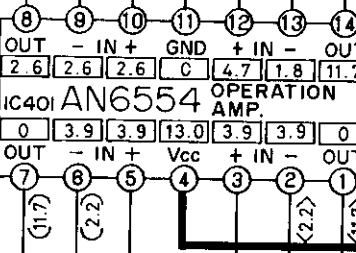
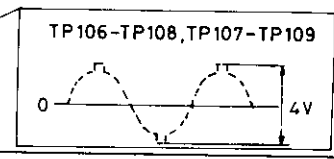

clock frequency adj.

Servo gain adj.

FC301

FC302

S701 30CM

S702 CABT.

EXPLODED VIEWS

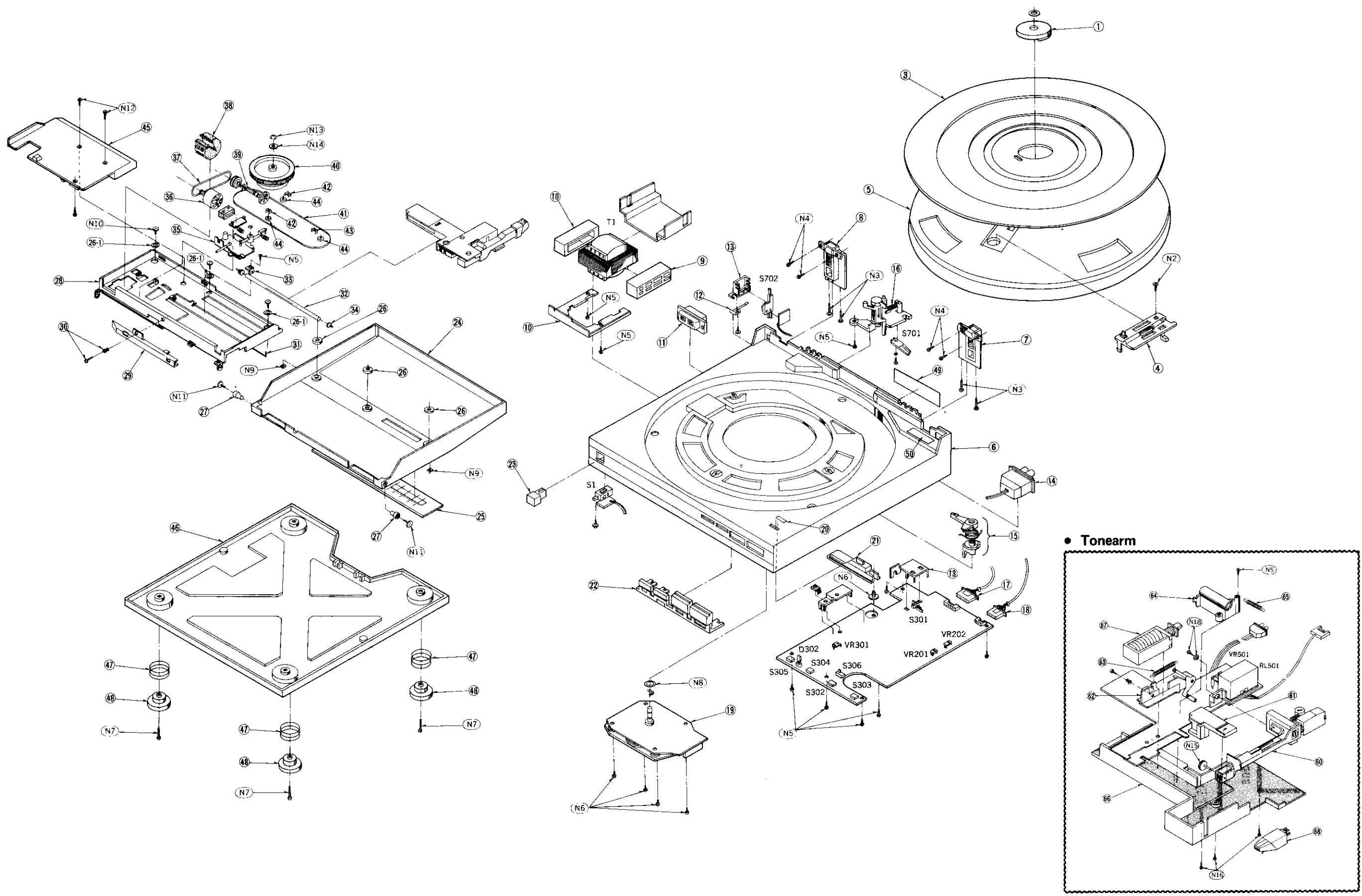

• Tonearm

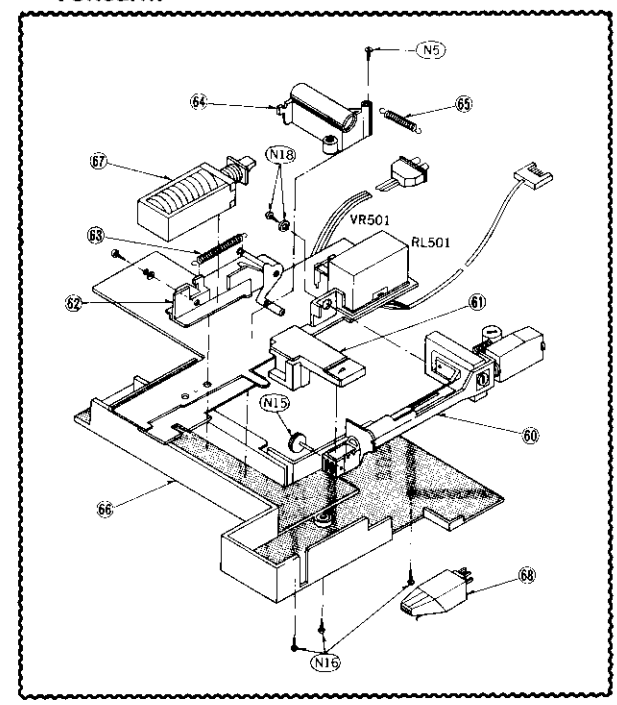

REPLACEMENT PARTS LIST.....Cabinet & Chassis Parts

- Notes:**
1. Part numbers are indicated on most mechanical parts. Please use this part number for parts orders.
 2. Important safety notice: Components identified by Δ mark have special characteristics important for safety. When replacing any of these components, use only manufacturer's specified parts.
 3. Bracketed indications in Ref. No. columns specify the area. Parts without these indications can be used for all areas.
 4. The "S" mark is service standard parts and may differ from production parts.

Areas

- * [E] is available in Switzerland and Scandinavia.
- * [EK] is available in United Kingdom.
- * [XL] is available in Australia.
- * [EG] is available in F.R. Germany.
- * [EB] is available in Belgium.
- * [EF] is available in France.
- * [XA] is available in Southeast Asia, Oceania, Africa, Middle Near East and Central South America.
- * [EH] is available in Holland.
- * [Ei] is available in Italy.
- * [EC] is available in Czechoslovakia.

Ref. No.	Part No.	Part Name & Description
CABINET and CHASSIS PARTS		
1	SFWEC05N01	45 Adaptor
3	SFTGC05N01	Turntable, Mat
4	SFUMC05N11A	Record Detector
5	SFTEC05N01A	Turntable
6	SFACC05N01	Cabinet
7	SFATC05N01A	Hinge, Right Side
8	SFATC05N02A	Hinge, Left Side
9	SFGCC05X01	Cushion Rubber, Power Transformer
10	SFUPC05N01	Plate, Power Transformer
11 [Other Areas]	Δ SFDJHSC0492	Socket, AC Power
11 [XA]	Δ SFDJHSC04912	Socket, AC Power
12	SFQPC05N01	Spring
13	SFUMC05N15	Cover, Switch
14	SFDHC05N02E	Socket, Input
15	SFUMC05N13E	Record Detector Lever
16	SFUMC05N07A	Record Side Detection Lever
17	SFDJC05N02E	Connector Ass'y (7P)
18	SFDJC05N03E	Connector Ass'y (5P)
19	SFMZC05N01Z	Stator Frame Ass'y
20	SFKKC05N02	Lable, Speed Selector
21	SFKTC05N02	Knob, Speed Selector
22	SFKTC05N01E	Knob, Start, Stop Ass'y
23	SBC425	Button, Power
24	SFADC05N01E	Dust Cover
25	SFKKC05N01	Surface Plate
26	SFGCC05N03	Cushion Rubber (A)
26-1	SFGCC05N04	Cushion Rubber (B)
27	SFGCC05N06	Cushion Rubber (C)
28	SFUKC05N01A	Arm Drive Plate
29	SFUMC05N20	Guide, Lead Wire
30	SFUZC05N03	Latch
31	SFUZC05N01	Rod, Rest Switch
32	SFXJC05N01	Guide Rail
33	SFUPC05N03	Plate, Guide Rail
34	SFGCC05N05	Cushion Rubber (D)
35	SFUMC05N02E	Plate, Rest Switch
36	SFMHC05N01E	Arm Drive Motor
37	SFGB10-01	Belt, Arm Drive (With Pulley)
38	SFGCC05N01	Cushion Rubber (E)
39	SFUMC05N16A	Worm Ass'y
40	SFUMC05N17	Arm Drive Wheel
41	SFUZC05N02E	Arm Drive Rope Ass'y
42	SFUMC07-22	Stopper, Pulley (A)
43	SFUMC05N23	Stopper, Pulley (B)
44	SFUMC05N22	Pulley
45	SFUMC05N01	Cover, Rest Switch Plate
46	SFAUC05N01	Bottom, Board
47	SFQCC05N01	Spring, Audio Insulator
48	SFGAC05N02E	Audio Insulator
49 [E]	SFNNC05S01	Name Plate
49 [EK, XL]	SFNNC05G01	Name Plate
49 [XA]	SFNNC05X01	Name Plate
49 [Other Areas]	SFNNC05R01	Name Plate
50	SFNHC05X01	Lable

Ref. No.	Part No.	Part Name & Description	
TONARM PARTS			
60	SFPAM00501A	Tonearm	
61	SFPAB00501E	Tonearm Position Indicator	
62	SFPJL00501E	Lift Plate Ass'y	
63	SFPSP00504	Spring, Lift	
64	SFPAB00502	Bracket, Tonearm	
65	SFPSP00503	Spring, Lead Wire	
66	SFPSC00501	Cover, Arm Base	
67	SFDZC05N01	Cueing Plunger	
68	★ EPC-P24S	Cartridge	
	★ EPS-24CS	Stylus	
SCREWS, WASHERS and CIRCLIPS			
N2	S	XTN3+6BFN	Screw, Tapping, \oplus 3 x 6
N3	S	XTV3+20BFN	Screw, Tapping, \oplus 3 x 20
N4	S	XTV3+6BFZ	Screw, Tapping, \oplus 3 x 6
N5	S	XTV3+8BFZ	Screw, Tapping, \oplus 3 x 8
N6	S	XTW3+10Q	Screw, Tapping, \oplus 3 x 10
N7	S	XTW3+20QFYR	Screw, Tapping, \oplus 3 x 20
N9	S	XNC3HS	Nut, ϕ 3
N10	S	SFXGC05N02	Screw
N11	S	SFXGC05N03	Screw
N12	S	XTV3+20BFZ	Screw, Tapping, \oplus 3 x 20
N13	S	SFXW551D2	Washer
N14	S	XUB3FY	Circlip, ϕ 3
N15	S	SFPEV00502	Screw
N16	S	XTV3+10BFZ	Screw, Tapping, \oplus 3 x 10
N17	S	XWC3B	Washer, ϕ 3
N18	S	XSN3+5S	Screw, Tapping, \oplus 3 x 5
ACCESSORIES			
A1 [E]	SFNUC05S01	Instructions Book, Printed Matter	
A1 [EK]	SFNUC05K01	Instructions Book, Printed Matter	
A1 [Other Areas]	SFNUC05X01	Instructions Book, Printed Matter	
A1 [EG]	SFNUC05G01	Instructions Book, Printed Matter	
A1 [EF]	SFNUC05F01	Instructions Book, Printed Matter	
A2	SFDHC05N01	Phono Cord	
A3	SFDLC05N01	Ground Wire	
A4 [EK]	S Δ RJA43Z	AC Cord	
A4 [XL]	S Δ RJA26Z	AC Cord	
A4 [Other Areas]	S Δ RJA20Z	AC Cord	
A5 [XA Only]	Δ SFDK119118	2P Plug	
A6	SFUMC05N24	Adapter, 25 cm Record	
PACKING PARTS			
P1 [EF Only]	SFHPC05C01	Carton Box	
P1 [Other Areas]	SFHPC05M01	Carton Box	
P2	SFHHC05N01	Pad, Front	
P3	SFHHC05N02	Pad, Rear	
P4	SFHDC05M01	Sheet, Turntable	
P5	SFHKC05N01	Screw, Clamp	
P6	SFHKC05N02	Spacer, Tonearm	
P7	SFHSC05N01	Spacer, Dust Cover	
P8	SFHSC05N02	Stopper, 45 Adaptor	
P9	SFYH45X50	Polyethylene, Bag, Unit	
P10	SFYH15X20	Polyethylene Bag, Accessory	
P11	SFYF05A06	Polyethylene Bag, 25cm Record Adapter	

PACKINGS

- 1. Set the tonearm to the start position.
- 2. Attach the arm spacer.

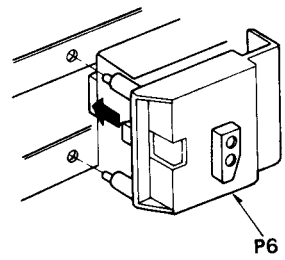

- 3. Attach the clamper, 45-adaptor holder and dust cover spacer.
- 4. Stick the protection sheet on the top of dust cover.

- 5. Put the set into the protection bag and then pack it as illustrated.

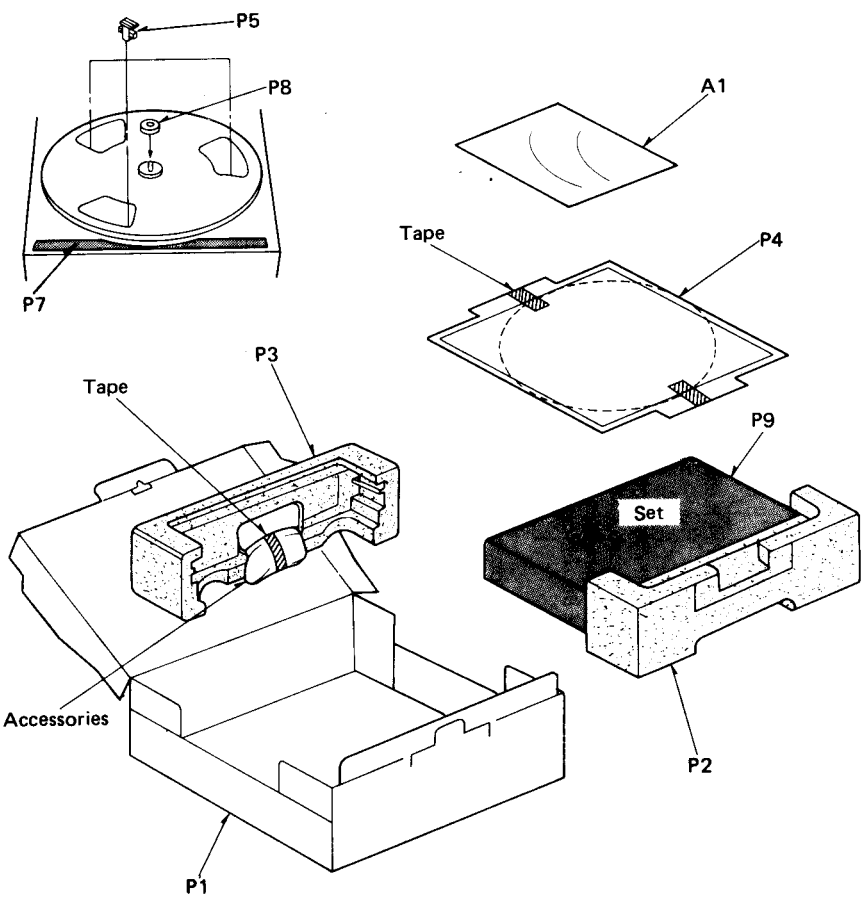

Service Manual

Direct Drive Automatic Turntable System

SL-5/(K)

Supplement-1

Please use this manual together with the service manual for Model No. SL-5,
Order No. SD81112090C2

- Notes:**
- ★ The circuit of SL-5 has been changed for the improvement of performance. The changes are mentioned in this supplement. Please keep this point in mind when servicing.
 - ★ This supplement should be filed with the service manual for Model No. SL-5. (Order No. SD81112090C2.)

CHANGES

■ SCHEMATIC DIAGRAMS

•Power source circuit

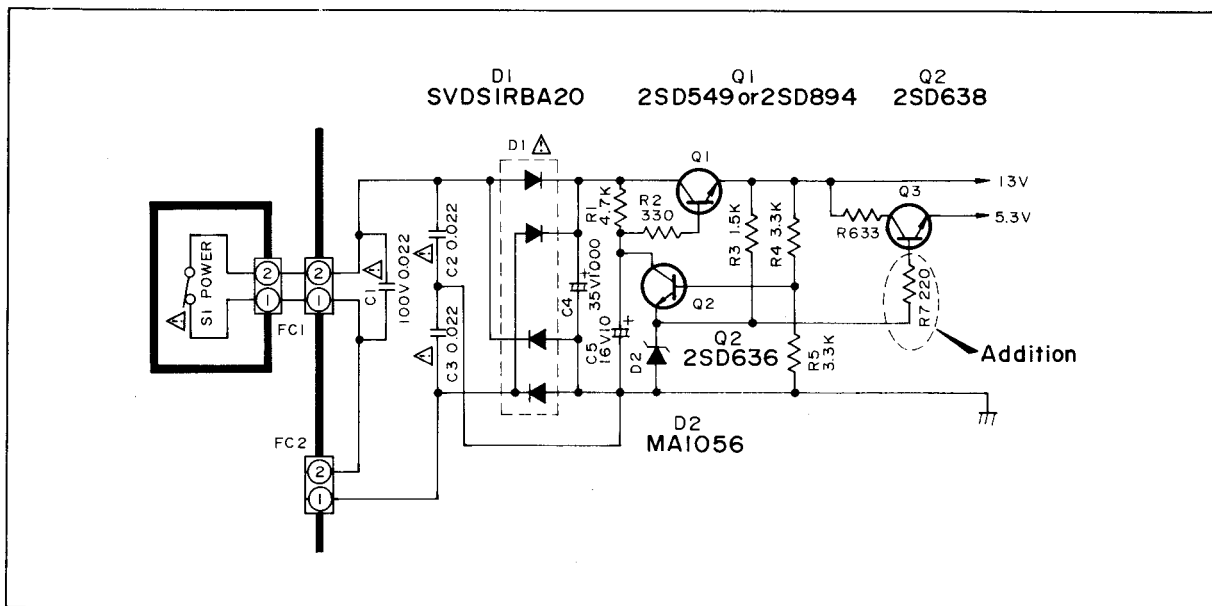

Note:

Regarding regulator transistor Q1, 2SD549 or 2SD894 is used.

In SL-5, 2SD549 is interchangeable with 2SD894. The supply of replacement parts is made by 2SD549.

•Arm position detection circuit

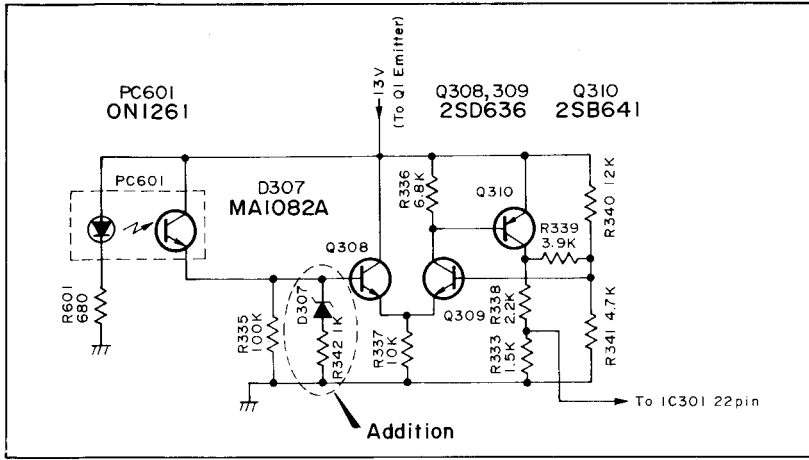

•Muting circuit

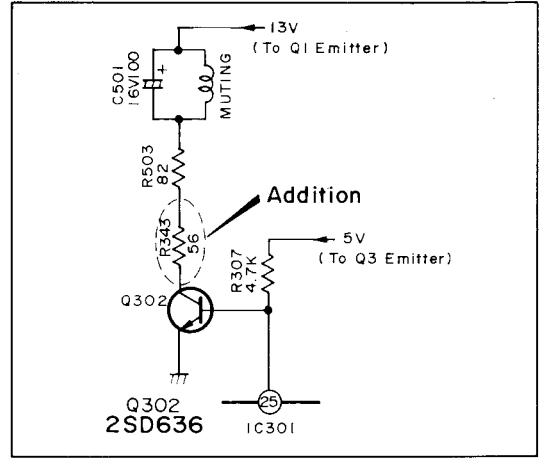

•Arm motor control circuit

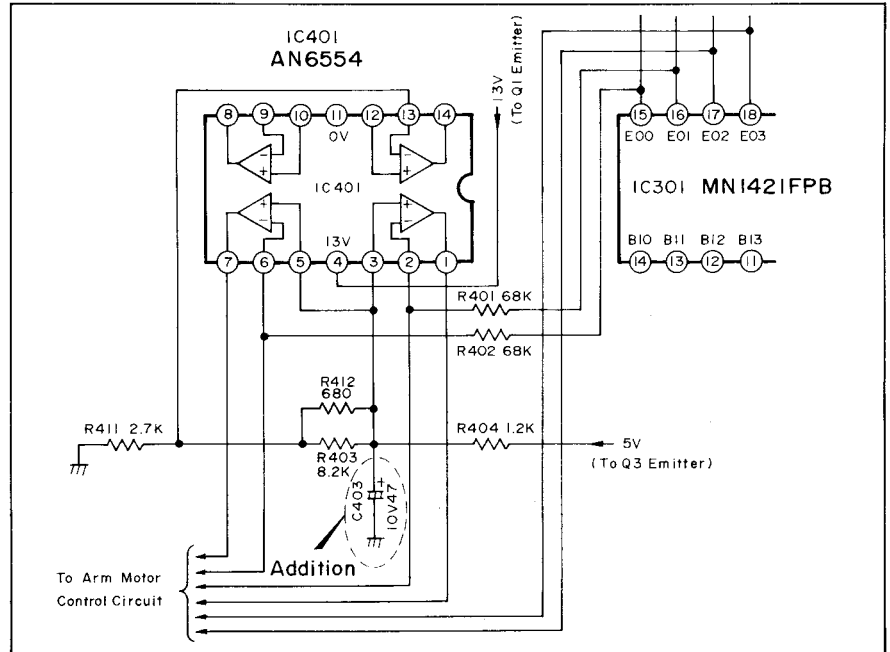
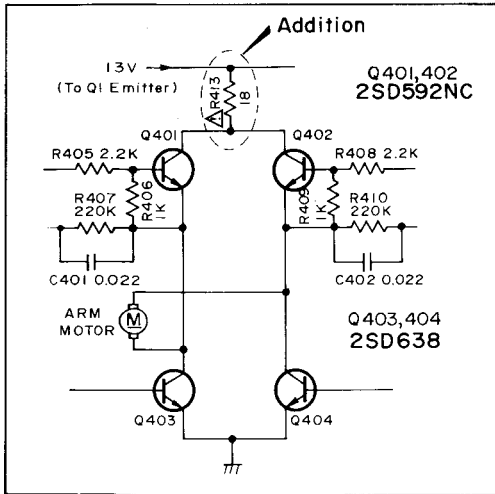

•Speed select circuit

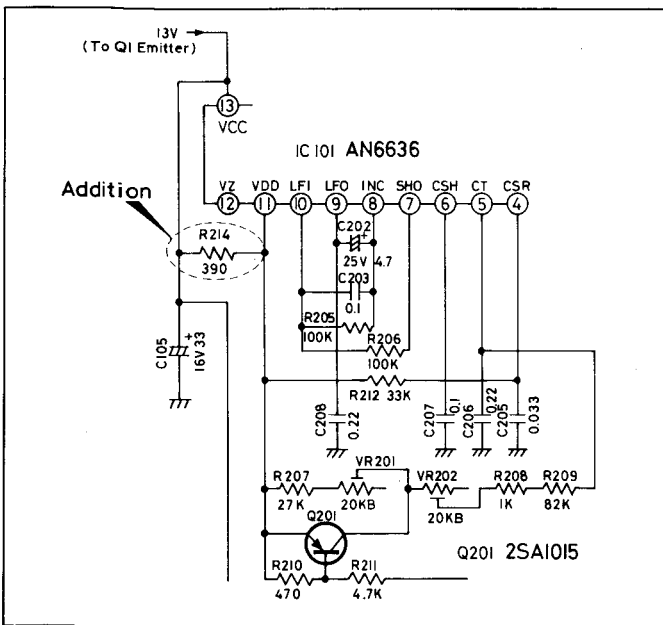

■ SHAPE OF HALL ELEMENT

★ Regarding the Hall elements for turntable position detection, OH-001 has been changed to OH-002 in the course of manufacture. Note that OH-001 is not interchangeable with OH-002. (They are different in shape and size.)

●OH-001

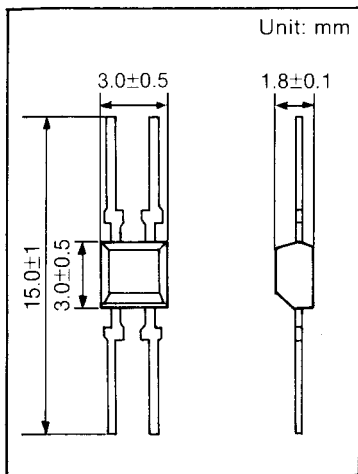

●OH-002

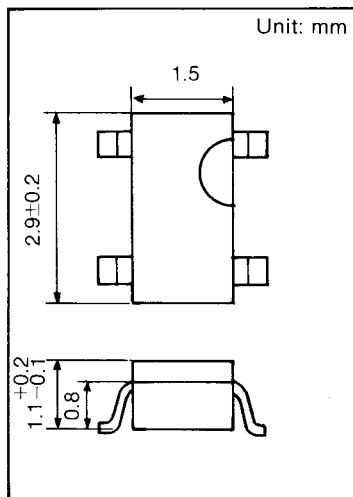

■ REPLACEMENT PARTS LIST

- Notes:**
1. This replacement parts list contains the main parts changed from those of former types.
 2. The "Ⓢ" mark is service standard parts and may differ from production parts.
 3. Important safety notice:
Components identified by mark have special characteristics important for safety. When replacing any of these components use only manufacturer's specified parts.

Ref. No.	Change of Part No.		Part Name & Description	Per Set (Pcs.)	Remarks
	SL-5 (OLD)	SL-5 (NEW)			
TRANSISTOR					
Q1	2SD549	2SD549 2SD894*	Transistor, Regulator	1	
*2SD894 is temporarily used as a substitute of 2SD549. 2SD549 has supplied for the Replacement Parts.					
DIODE					
D307	Addition	MA1082	Zener Diode, 8.2V Constant Voltage	1	
VARIABLE RESISTOR					
VR301	EVNK6JA00B24	EVNK6AA00B54	Clock Freq. Adjustment, 50kΩ (B)	1	
HALL ELEMENT					
H1, 2	OH-001	OH-001 OH-002*	Turntable Position Detector	2	
*OH-001 has been changed to OH-002 in the course of manufacture. Note that OH-001 is not interchangeable with OH-002 when you order this one.					
FUSE					
F1	XBA2C06T1B	XBA2C05T1B	T500mA, 250V	1	

Ref. No.	Change of Part No.		Part Name & Description	Per Set (Pcs.)	Remarks
	SL-5 (OLD)	→ SL-5 (NEW)			
RESISTORS					
R7	Addition	ERD25FJ221	Carbon 1/4W, 220Ω, ±5%	1	Ⓢ
R208	ERD25FJ562	ERD25FJ102	Carbon 1/4W, 1kΩ, ±5%	1	Ⓢ
R214	Addition	ERD25FJ391	Carbon 1/4W, 390Ω, ±5%	1	Ⓢ
R302, 303	ERD25FJ472	ERD25FJ102	Carbon 1/4W, 1kΩ, ±5%	2	Ⓢ
R304, 305	ERD25FJ472	ERD25FJ152	Carbon 1/4W, 1.5kΩ, ±5%	2	Ⓢ
R326	ERD25FJ222	ERD25FJ272	Carbon 1/4W, 2.7kΩ, ±5%	1	Ⓢ
R337	ERD25TJ273	ERD25FJ103	Carbon 1/4W, 10kΩ, ±5%	1	Ⓢ
R339	ERD25TJ123	ERD25FJ392	Carbon 1/4W, 3.9kΩ, ±5%	1	Ⓢ
R340	ERD25FJ272	ERD25TJ123	Carbon 1/4W, 12kΩ, ±5%	1	Ⓢ
R341	ERD25FJ222	ERD25FJ472	Carbon 1/4W, 4.7kΩ, ±5%	1	Ⓢ
R342	Addition	ERD25FJ102	Carbon 1/4W, 1kΩ, ±5%	1	Ⓢ
R343	Addition	ERD25FJ560	Carbon 1/4W, 56Ω, ±5%	1	Ⓢ
R403	ERD25FJ472	ERD25FJ822	Carbon 1/4W, 8.2kΩ, ±5%	1	Ⓢ
R413	Addition	ERD2FCG180	Fuse Type Carbon 1/4W, 18Ω, ±5%	1	⚠
R503	ERD25FJ221	ERD25FJ820	Carbon 1/4W, 82Ω, ±5%	1	Ⓢ
CAPACITORS					
C1	ECKD1H223PF	ECQM1223KZ	Polyester, 100V, 0.022μF, ±10%	1	⚠
C103, 104	ECEA1CN101S	ECEA1CN470S	Non-Polar Electrolytic, 16V, 47μF	2	Ⓢ ⚠
C210	ECKD1H223PF	ECKD2H102KB	Ceramic, 500V, 0.001μF, ±10%	1	
C301	ECCD1H101K	ECCD1H680K	Ceramic, 50V, 68PF, ±10%	1	Ⓢ
C403	Addition	ECEA1AS470	Electrolytic, 10V, 47μF	1	Ⓢ

Service Manual

Direct Drive Automatic Turntable System

SL-5 (W)

[E]

SL-5 (R)

[E]

SL-5 (B)

[E]

* The cabinet and Panel are available in white color, red color and blue types.
* The white, red and blue types model is provided with (W), (R), (B) in the Service Manual.

Area

* [E] is available in Scandinavia and Switzerland.

Please use this manual together with the service manual for Model No. SL-5 [E]

Order No. SD81112090C2.

CHANGES

REPLACEMENT PARTS LIST

Ref. No.	Change of Part No.		Description & Pcs.	Remarks
	SL-5 [E] (Order No. SD81112090C2)	→ SL-5 [E] (W), (R), (B)		
CABINET PARTS				
6	SFACC05N01	SFACC05N03 (White)	Cabinet (1)	
		SFACC05N02 (Red)		
		SFACC05N04 (Blue)		
24	SFADC05N01E	SFADC05N03E (White)	Dust Cover (1)	
		SFADC05N02E (Red)		
		SFADC05N04E (Blue)		
PACKING PARTS				
	Addition	SFHZC05S03 (White)	Label (Carton Box) (1)	
		SFHZC05S01 (Red)		
		SFHZC05S02 (Blue)		

Technics

Matsushita Electric Trading Co., Ltd.
P.O. Box 288, Central Osaka Japan

Service Manual

Direct Drive Automatic Turntable System

SL-5(K)

[E], [EG], [EH], [XA]

- * The cabinet and dust cover are available in black color and silver types.
- * The black type model is provided with (K) in the Service Manual.

Areas

- * [E] is available in Switzerland and Scandinavia.
- * [EG] is available in F.R. Germany.
- * [EH] is available in Holland.
- * [XA] is available in Southeast Asia, Oceania, Africa, Middle Near East and Central South America.

Please use this manual together with the service manual for Model No. SL-5 Order No. SD81112090C2.

CHANGES

REPLACEMENT PARTS LIST

Ref. No.	Change of Part No.		Part Name & Description	Per Set (Pcs.)	Remarks
	SL-5 (ORDER NO. SD81112090C2)	SL-5 (K) [E, EG, EH, XA]			
CABINET and CHASSIS PARTS					
6	SFACC05N01	SFACC05S21	Cabinet (Black)	1	
20	SFKKC05N02	SFKKC05N21	Label, Speed Selector	1	
24	SFADC05N01E	SFADC05S21E	Dust Cover (Black)	1	
PACKING PARTS					
P1	SFHPC05C01 [EF]	SFHPC05M21	Carton Box	1	
	SFHPC05M01 [Other Areas]				

Technics

Matsushita Electric Trading Co., Ltd.

P.O. Box 288, Central Osaka Japan

 Printed in Japan
 82016300 Ⓜ AM

Service Manual

Direct Drive Automatic Turntable System

SL-5

[PA], [PE], [PC]

Areas

- * [PA] is available in for East PX.
- * [PE] is available in European Military.
- * [PC] is available in European Audio Club.

Please use this manual together with the service manual for Model No. SL-5 Order No. SD81112090C2.

CHANGES

■ REPLACEMENT PARTS LIST

Ref. No.	Change of Part No.		Part Name & Description	Per Set (Pcs.)	Remarks
	SL-5 (ORDER NO. SD81112090C2)	SL-5 [PA, PE, PC]			
SWITCH					
S901	SFDSHXW225-2 [XA] only	SFDSHXW225-2	Switch, Voltage Selector	1	
FUSES					
F1	XBA2C02T1B [XA]	XBA2C02T1B	Fuse, T 200mA 250V	1	
	XBA2C06T1B [Other Areas]				
F2	XBA2C06T1B [XA] only	XBA2C06T1B	Fuse, T 630mA 250V	1	
POWER TRANSFORMER					
T1	SLT48DT4E [EK, XL]	SLT57DT1E	Power Transformer	1	
	SLT57DT1E [XA]				
	SLT48DT3E [Other Areas]				
CABINET and CHASSIS PARTS					
11	SFDJHSC04912 [Other Areas]	SFDJHSC04912	Socket, AC Power	1	
	SFDJHSC04912 [XA]				
49	SFNNC05S01 [E]	SFNNC05P01 [PA, PE]	Name Plate	1	
	SFNNC05G01 [EK, XL]				
	SFNNC05X01 [XA]	SFNNC05P02 [PC]	Name Plate	1	
	SFNNC05R01 [Other Areas]				
ACCESSORIES					
A1	SFNUC05S01 [E, EB, EH, EC]	SFNUC05G01	Instructions Book, Printed Matter	1	
	SFNUC05G01 [EK, XL]				
	SFNUC05X01 [XA]				
	SFNUC05R01 [EG]				
	SFNUC05F01 [EF]				
	SFNUC05I01 [Ei]				

Technics

Panasonic Tokyo
Matsushita Electric Industrial Co., Ltd.
1-2, 1-chome, Shibakoen, Minato-ku, Tokyo 105 Japan

Matsushita Electric Trading Co., Ltd.
P.O. Box 288, Centre Osaka Japan

Ref. No.	Change of Part No.		Part Name & Description	Per Set (Pcs.)	Remarks
	SL-5 (ORDER NO. SD81112090C2)	SL-5 [PA, PE, PC]			
A4	RJA43Z [EK]	QFC1100	AC Cord	1	
	RJA26Z [XL]				
	RJA20Z [Other Areas]				
	QFC1103 [XA]				
A5	SFDK119118	Deletion	0	
A7	Addtion	QJP0603S	Adaptor, Gimens	1	
PACKING PARTS					
P1	SFHPC05C01 [EF]	SFHPC05M01	Carton Box	1	
	SFHPC05M01 [Other Areas]				

Service Manual

Direct Drive Automatic Turntable System

SL-5(K)

[PA], [PE], [PC]

* The colors of this model include silver and black.
* The black type model is provided with (K) in the Service Manual.

Areas

* [PA] is available in Far East PX.
* [PE] is available in European Military.
* [PC] is available in European Audio Club.

Please use this manual together with the service manual for Model No. SL-5, Order No. SD81112090C2.

CHANGES

REPLACEMENT PARTS LIST

Note:

☒ —marked parts are used for black only, while
○ —marked parts are for silver tupe only.

Ref. No.	Change of Part No.		Part Name & Description	Per Set (Pcs.)	Remarks
	SL-5 (ORDER NO. SD81112090C2)	SL-5 (K) [PA, PE, PC]			
SWITCH					
S901	SFDSHXW225-2 [XA] only	SFDSHXW225-2	Switch, Voltage Selector	1	
FUSES					
F1	XBA2C02T1B [XA]	XBA2C02T1B	Fuse, T200mA 250V	1	
	XBA2C06T1B [Other Areas]				
F2	XBA2C06T1B [XA] only	XBA2C06T1B	Fuse, T630mA 250V	1	
POWER TRANSFORMER					
T1	SLT48DT4E [EK, XL]	SLT57DT1A	Power Transformer, Power Source	1	
	SLT57DT1A [XA]				
	SLT48DT3E [Other Areas]				
CABINET and CHASSIS PARTS					
6	SFACC05N01 ○	SFACC05S21 ☒	Cabinet (Black)	1	
11	SFDJHSC0492 [Other Areas]	SFDJHSC04912	Socket, AC Cord	1	
	SFDJHSC04912 [XA] only				
20	SFKKC05N02 ○	SFKKC05N21 ☒	Label, Speed Selector (Black)	1	
24	SFADC05N01E ○	SFADC05S21E ☒	Dust Cover (Black)	1	
49	SFNNC05S01 [E, EC]	SFNNC05P01 [PA, PE]	Name Plate	1	
	SFNNC05G01 [EK, XL]				
	SFNNC05X01 [XA]	SFNNC05P02 [PC]	Name Plate	1	
	SFNNC05R01 [Other Areas]				
68	PEC-P24S	EPC-P28	Cartridge	1	
	EPS-24CS	EPS-28ES	Stylus	1	

Technics

Panasonic Tokyo
Matsushita Electric Industrial Co., Ltd.
1-2, 1-chome, Shibakoen, Minato-ku, Tokyo 105 Japan

Matsushita Electric Trading Co., Ltd.
P.O. Box 288, Central Osaka Japan

Ref. No.	Change of Part No.		Part Name & Description	Per Set (Pcs.)	Remarks
	SL-5 (ORDER NO. SD81112090C2)	→ SL-5 (K) [PA, PE, PC]			
ACCESSORIES					
A1	SFNUC05G01 [EK, XL]	SFNUC05G01	Instruction Book	1	
	SFNUC05X01 [XA]				
	SFNUC05R01 [EG]				
	SFNUC05F01 [EF]				
	SFNUC05I01 [Ei]				
	SFNUC05S01 [Other Areas]				
A4	RJA43Z [EK]	QFC1100	AC Cord	1	
	RJA26Z [XL]				
	RJA20Z [Other Areas]				
A5	SFDK119118 [XA] only	Deletion	0	
A7	Addtion	QJP0603S	Adaptor, Gimens	1	
PACKING PART					
P1	SFHPC05C01 [EF] only <input type="radio"/>	SFHPC05M21 <input checked="" type="checkbox"/>	Carton Box (Black)	1	
	SFHPC05M01 [Other Areas] <input type="radio"/>				

Technical Information

INTRODUCTION

This technical information is a summary of quality problems encountered with OSD products, which have occurred in JAPAN and overseas.

This technical information is issued as a reference to help you improve your servicing by reporting problems which have occurred in various markets.

Please keep the contents strictly confidential.

We hope you find the contents useful.

CONTENTS

Ref NO.	MODEL	TROUBLES - REPORTED
L - 24	SL-5, DL5	Return position is abnormal.
L - 25	SL-Q33, D33	Turntable does not stop or start without start command.
B - 1	SB-G900	New technical information.



YASUHIKO IWAMI

G.M.
STEREO DIVISION
SERVICE DEPARTMENT

SUBJECT	Return position is abnormal.
---------	------------------------------

Model	SL-5, DL5
-------	-----------

Information from:	JAPAN
-------------------	-------

Symptom	Return timing of tonearm is too fast. Tonearm is returning before music completed.
---------	---

Cause and Explanation	<p>Pulus counter circuit is misscounted by the pulus noise which come from unstable rotation of pulus count mechanism.</p>
-----------------------	--

REMEDY	<p>Please change following resistors to improve pulus-shaping circuit.</p> <p>R337 27kohm → 10kohm R339 12kohm → 3.9kohm R340 2.7kohm → 12kohm R341 2.2kohm → 4.7kohm</p>
--------	--

Effective Date	<p>1. Cannot find this phenomenon by manual operating. 2. Nonstandard cutting disc cannot improve by this remedy.</p>
----------------	--

SUBJECT	Turntable does not stop or start without start command.
---------	---

Model	SL-Q33,D33
-------	------------

Information from:	JAPAN
-------------------	-------

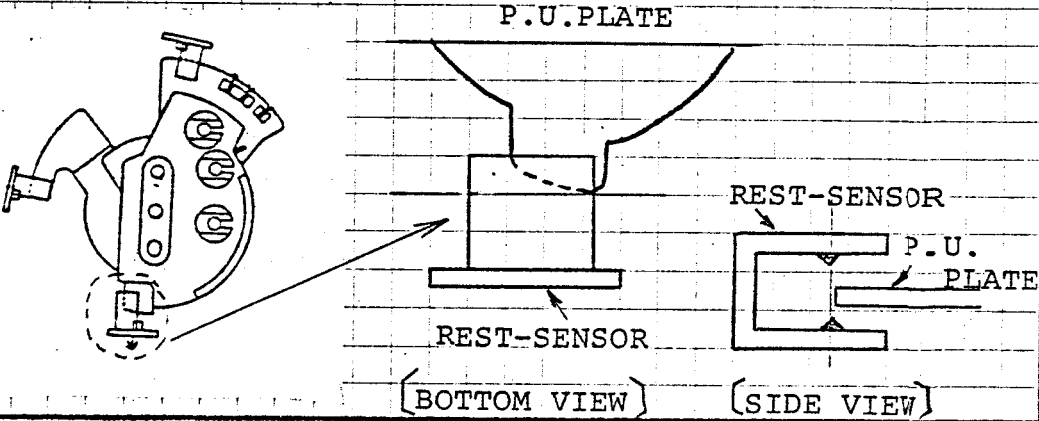
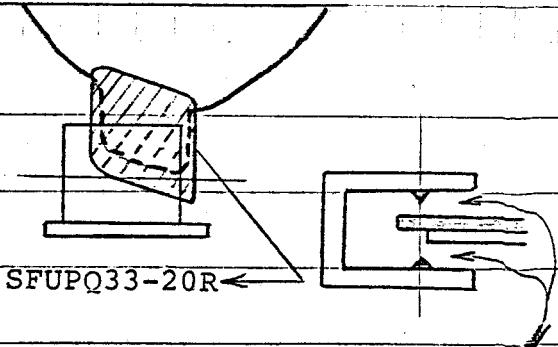
Symptom.	<p>P.U.plate was incorret position at rest sensor.</p> <p>1.Turntable does not stop after the pick up return to the rest.</p> <p>2.Turntable begin to rotate before pressing the start switch.</p>
Cause and Explanation	<p>P.U.plate was incorret position at rest sensor.</p> <p>(TONE ARM FIXING PLATE ASSY)</p> 
Remedy	<p>Please stick SFUPQ33-20R on to the P.U. plate.</p>  <p>Adjust clearance</p> <p>Keep the safety clearance by adjusting the fixing screws of the rest sensor, after that fix screws with glue.</p>
Effective Date	When you get such problem,please order SFUPQ33-20R to us.

SUPER BASS WOOFER utilized in the Speaker system SB-G900

- Features
1. High efficiency 99dB/Watt at 1m
 2. High handling power 300Watt max music input
 3. Low intermodulation distortion

Conventional Woofer

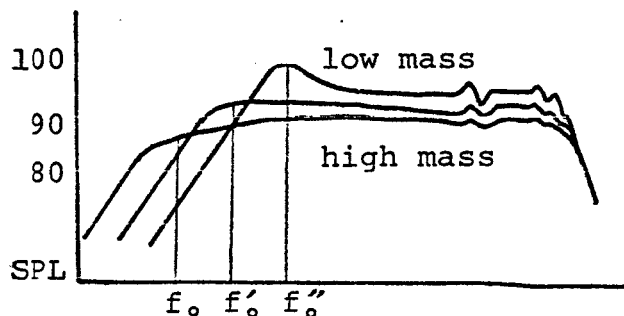
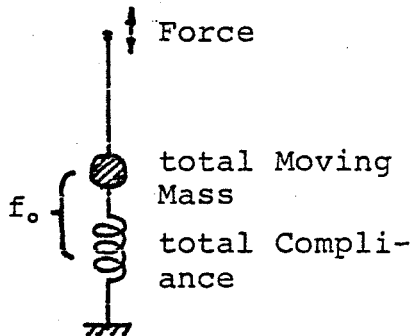
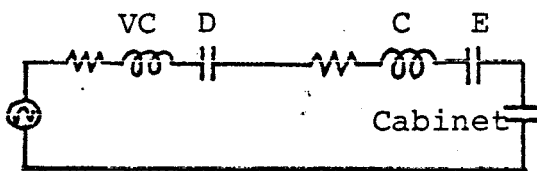
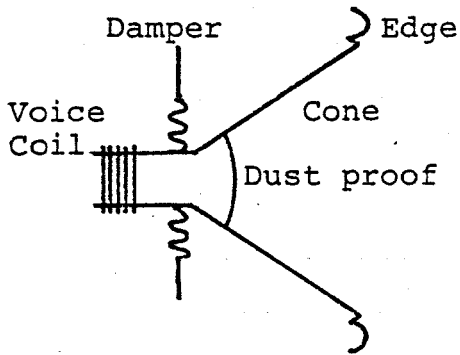

Hard to get low f_0 with high SPL
 When use light Corn to increase the Efficiency, then the f_0 will be higher.
 When use heavy Corn to lower the f_0 , then the efficiency will decrease

Super Bass Woofer

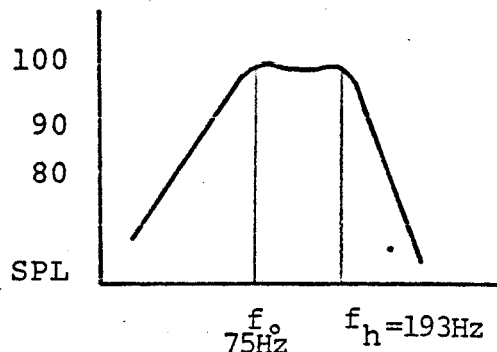
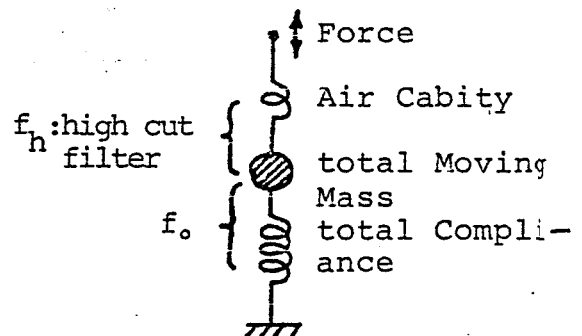
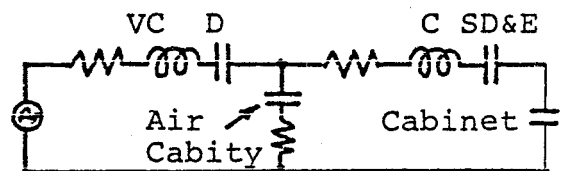
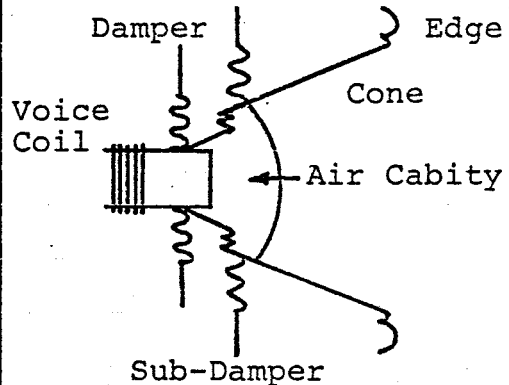

Low f_0 with high Efficiency
 When choose the f_0, f_h, B, Q at optimum condition, then low f_0 with high efficiency and lower intermodulation distortion system can be obtained.